

EX LIBRIS

ENGINEERING LIBRARY

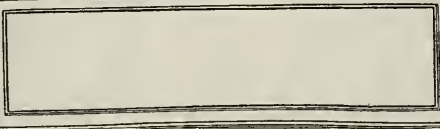



Digitized by the Internet Archive
in 2008 with funding from
Microsoft Corporation



A. L. Dewett 3076.

A MANUAL
OF
NAVAL ARCHITECTURE.

FOR THE USE OF

OFFICERS OF THE ROYAL NAVY,
OFFICERS OF THE MERCANTILE MARINE,
SHIPBUILDERS, SHIPOWNERS,
AND YACHTSMEN.

BY W. H. WHITE, F.R.S.,

ASSISTANT CONTROLLER AND DIRECTOR OF NAVAL CONSTRUCTION, ROYAL NAVY;
VICE-PRESIDENT OF THE INSTITUTION OF NAVAL ARCHITECTS;
MEMBER OF THE INSTITUTIONS OF CIVIL ENGINEERS AND MECHANICAL ENGINEERS;
FELLOW OF THE ROYAL SCHOOL OF NAVAL ARCHITECTURE.

SECOND EDITION, REVISED AND ENLARGED.

*The Lords Commissioners of the Admiralty have been pleased to authorise the
issue of this Book to the Ships of the Royal Navy.*

LONDON:
JOHN MURRAY, ALBEMARLE STREET.

1889.

[The right of Translation is reserved.]

VM
145
W5
1889
Surg.
1/14

ENGINEERING LIBRARY

LONDON :

PRINTED BY WILLIAM CLOWES AND SONS, LIMITED,

STAMFORD STREET AND CHARING CROSS.

PREFACE TO SECOND EDITION.

IN preparing this new edition it has been my endeavour to leave the original plan of the work unchanged in its main features; but to bring the information given for all classes of ships up to the date of publication, to correct faults, and to make additions or extensions wherever they appeared desirable. To a large extent the book has been rewritten, and a considerable amount of new matter has been introduced, with the result of enlarging the contents of the volume by about one-third as compared with its predecessor.

The wide circulation which the first edition has attained both in this country and abroad has been an incentive to me to spare no pains in the revision now completed. So far as the scanty leisure of a busy professional life has permitted, I have endeavoured to add to the value and interest which the work may have for all the classes of readers for whom it is designed. If complete success has not been attained in this endeavour—as indeed it is scarcely to be hoped for—an apology will hardly be needed.

The exact and extensive information for various types of merchant ships given in the following pages I owe to the courtesy of many of the leading shipbuilding firms, whose practice in recent years has been marked by rapid extensions of scientific method. In this respect the present volume is distinguished from the earlier edition perhaps more than in any other. The sources of information are acknowledged in all cases; but I would here record the special obligations I am under to my friends Mr. John Inglis, junior, and Mr. William Denny, for their ready and

repeated help in my inquiries into questions relating to the mercantile marine.

Another distinctive feature of this edition will be found in the amplification of those portions of the work which are likely to be of value to readers engaged in the design and construction of ships. My most sanguine anticipations have been exceeded in the welcome which the first edition received from shipbuilders, naval architects and engineers; and I trust that they will find the present volume much more valuable as a book of reference.

At the same time, I venture to hope that the naval officer, the shipowner and the yachtsman will find the book no less suited to their wants or less readable than before. It was in the hope of serving them chiefly that I first undertook the task, and my desire to be of service is as strong as ever.

To Mr. W. E. Smith of the Controller of the Navy's Department my thanks are due for valuable assistance rendered in the passage of this edition through the press.

W. H. WHITE.

LONDON, 1882.

PREFACE TO FIRST EDITION.

THIS book has been undertaken in the hope that it may supply a want in the literature of naval architecture. Existing treatises have been written mainly for the use of those who desired to obtain the knowledge of the subject required in the practice of ship designing; in all, or nearly all, these books mathematical language is freely used, and without a considerable knowledge of mathematics no one can follow the reasoning. My work at the Royal Naval College has, however, shown me that outside the profession of the naval architect there are to be found very many persons, more or less intimately connected with shipping, who desire to obtain acquaintance with the principles of ship construction, but cannot obtain the information from existing text-books. Officers of the Royal Navy have repeatedly asked me to recommend a book which contained, in popular language, a comprehensive summary of the theory of naval architecture. Being unable to name such a book, and feeling confident that the desire expressed by officers of the Royal Navy will be shared by many officers of the mercantile marine, as well as shipbuilders, shipowners, and others, I decided to attempt the task now completed. I venture to hope that the work may be found acceptable also as an introduction for students to the more mathematical treatment of the subject contained in other works, and that even naval architects themselves may find some valuable information herein.

Throughout the book, so far as seemed possible, popular language is employed; where mathematical language is used, it is of the simplest character. Explanations are given of many terms and mechanical principles, which need no explanation to readers possessing a good knowledge of mathematics; this course having been followed in order to assist the general reader,

and render it unnecessary for him to turn to other books. The details of many important theoretical investigations are necessarily omitted; but the general modes of procedure are sketched, and the practical deductions are fully explained. These deductions are clearly of the greatest value to the readers for whom the book is mainly designed; and it has been my endeavour to make the survey of the theory of naval architecture, from this point of view, as complete as possible. Practical shipbuilding is not treated of; but in the chapters on Strains, Structural Strength, and Materials for Shipbuilding, will be found an outline of the principles which govern the work of the shipbuilder, and an account of the principal features of the structures in various types of ships. The principal deductions from theory respecting the buoyancy, stability, behaviour, resistance, propulsion, and steering of ships, are set forth at length; practical rules are given for regulating the draught and stowage of ships, observing their behaviour at sea, and noting the dimensions of ocean waves. In every case numerous illustrations of these deductions are drawn from the particulars and performances of representative ships, belonging to English or foreign navies, and to the mercantile marine. Ships of war naturally receive most attention, the information respecting them being more exact and extensive than the corresponding facts for merchant ships; but the latter will also be found to receive considerable notice, the latest types of clipper sailing ships and mail steamers being described, and their performances discussed. The classes of warships for which particulars are given range from the sailing ships of half a century ago up to the circular ironclads and central-citadel ships of the present day.

Apart from the illustrative use made of these facts, it is hoped that the mass of information thus brought together, some of which has never before been published, will add to the value of the book. Not only naval officers, but naval architects, may be glad to have brought together in a compact form, and made easy of reference, much information that either lies scattered or is inaccessible elsewhere. To the notice of naval architects also I would venture to recommend the chapters on Steam Propulsion and Steering.

One great object which I have kept in view throughout has been to endeavour to awaken in the minds of seamen an intelligent interest in the observations of deep-sea waves and the behaviour of ships. Upon such observations further progress in the theory of naval architecture largely depends; and although much has

been done of late years, especially by officers of the Royal Navy, still more remains to be done.

The success which has already attended my endeavours to popularise a few out of the many problems of ship design, in lectures delivered at the Royal Naval College to naval officers, leads me to hope that a similar mode of treatment applied, as in the present work, to the whole range of naval architecture may be welcomed by a wider circle of readers. One incentive to undertake the book was found in the requests made by many officers who attended the lectures that they might be published; but it seemed preferable to enlarge their scope considerably before publication, and although much of the material used for the lectures has been embodied in this book, it considerably amplifies and extends the treatment of the subjects included in the four courses of lectures.

Much of the information contained in this book has necessarily been drawn from the works of other writers; in all such cases I have endeavoured to acknowledge the sources of information. In a few cases the substance of papers of my own, previously published, has been used; these cases are also mentioned in the text.

W. H. WHITE.

LONDON, 1877.

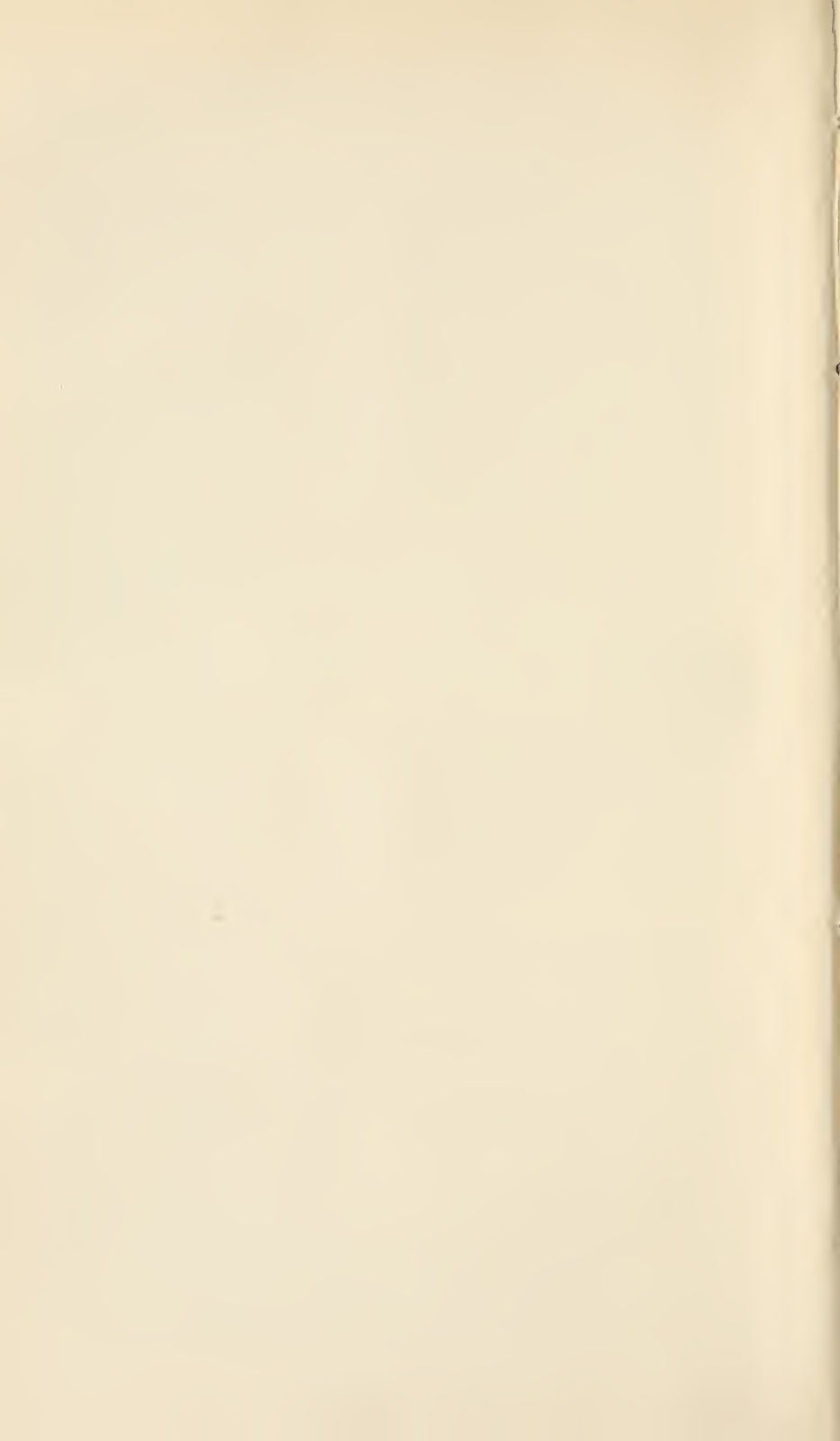

CONTENTS.

CHAPTER I.

THE DISPLACEMENT AND BUOYANCY OF SHIPS.

	PAGE
Definitions of displacement and buoyancy	1
Useful displacement, or carrying power	2
Approximate rules for estimating displacement	3
Curves of displacement: their construction and uses	6
Curves of tons per inch immersion: their construction and uses	7
Changes in draught of water produced by the passage of ships from the sea to rivers or docks	9
Reserve of buoyancy for various types of ships	10
Submarine vessels: fundamental principles of construction	12
Foundering of ships which are "swamped." Water-logged ships	14
Foundering of ships which have bottoms penetrated	15
Principles of watertight subdivision of ships:—	
By transverse bulkheads	18
By longitudinal bulkheads	22
By decks or platforms	23
Watertight subdivision in modern war-ships	25
Cellular double bottoms	28
Examples of foundering caused by collision	30
Unsinkable ships	32
Freeboard: rules for	33
Load-draught: recent legislation respecting	34

CHAPTER II.

THE TONNAGE OF SHIPS.

Early systems of tonnage measurements	36
Builders' old measurement	38
Displacement tonnage: for war-ships	43
Financial tonnage (Navy Estimates)... ..	43
New measurement (law of 1836)	44
Register tonnage (law of 1854)	46
Suez Canal and Danube rules	58
Tonnage laws of other maritime nations	59
Proposed revision of British tonnage law:—	
Dead-weight tonnage	61
Displacement tonnage	64
Parallelopipedon tonnage	66

	PAGE
Freight tonnage	67
Yacht measurements: for time allowances:—	
Thames rule	67
Yacht Racing Association	68
Other rules	69

CHAPTER III.

THE STATICAL STABILITY OF SHIPS.

Condition of ships floating freely in still water	73
" " inclined by mechanical couple	74
Stable, unstable, and indifferent equilibrium	75
Statical stability defined	76
Metacentre for transverse inclinations	77
Stiffness, crankness, and steadiness	77
Metacentric heights: for war-ships	79
" " for merchant steamers	80
" " for sailing ships and yachts	84
Conditions governing the vertical position of the metacentre and centre of buoyancy	88
Metacentric diagrams: construction and uses of	91
Stability of cigar-ships and submarine vessels	97
Inclining experiments: to determine vertical position of centres of gravity of ships	99
Effect upon stability of vertical movements of weights	102
Heeling produced by transverse shift of weights	102
Effect upon stability of water in hold	104
" " of additions of removals of weights	108
Metacentre for longitudinal inclinations	109
Estimates for change of trim	112
Stability of ships partially waterborne	115
Atwood's formula for statical stability	118
Curves of stability: construction of	119
" " causes influencing form and range	120
" " examples for war-ships	123
" " examples for merchant steamers	126
" " examples for sailing ships	128

CHAPTER IV.

THE OSCILLATIONS OF SHIPS IN STILL WATER.

Comparison of ships with pendulums	132
Angular velocity, accelerating force, and moment of inertia	134
Instantaneous axis for unresisted rolling	137
Motion of metacentre during rolling	139
Formula for period of unresisted rolling	140
Changes in period produced by changes in distribution of weights	141
Dynamical stability: modes of estimating	144

	PAGE
Dipping oscillations	147
Effect of fluid resistance on rolling	149
Rolling experiments in still water	151
Still-water periods for typical war-ships	155
Curves of extinction and their analysis	157
Usefulness of bilge-keels	162
Effect of free-water in interior upon rolling	165
Effect of gusts or squalls of winds on rigged ships floating in still water	168

CHAPTER V.

DEEP-SEA WAVES.

Fundamental conditions of trochoidal theory	175
Construction of trochoidal profiles	177
Orbital motions of particles and advance of wave-form	178
Internal structure of wave	180
Variations in direction and intensity of fluid pressure incidental to wave motion	183
Formulae for dimensions and speeds of waves	187
Observations of waves: methods of conducting	190
" " summary of maximum dimensions recorded	194
Comparison of observation with theory	197
Conditions of a confused sea	200
The genesis of waves	201
Relation of force of wind to dimensions of waves	204
Prevalent waves in different regions	208
Utilisation of wave power	208

CHAPTER VI.

THE OSCILLATIONS OF SHIPS AMONG WAVES.

Early theories of rolling	210
Principal features of modern theory of rolling	211
The effective wave slope and virtual upright	213
Fundamental assumptions for mathematical investigation of unresisted rolling	218
Critical cases of rolling of ships:—	
Amongst waves of synchronising periods	220
“Permanent” oscillations	223
Phases of oscillation	225
Practical deductions from investigation of unresisted rolling, compared with observations of the rolling of ships at sea	227
Influence of fluid resistance upon rolling	235
Graphic integration for resisted rolling: Mr. Froude's method	237
M. Bertin's investigation for resisted rolling	239
Influence of bilge-keels in steadying ships	241
Usefulness of “water-chambers” in armoured ships	243
Rolling of ships with sail set	245
Effect of gusts and squalls of wind	249

	PAGE
Steadying effect of sails	251
Longitudinal oscillations: pitching and 'scending	252
Principal conditions affecting longitudinal oscillations	253
Influence of fluid resistance upon these motions	258

CHAPTER VII.

METHODS OF OBSERVING THE ROLLING AND PITCHING MOTIONS OF SHIPS.

Necessity for such observations	261
Pendulum observations, and their errors	263
Spirit-levels and clinometers	267
Gyroscopic instruments and their drawbacks	268
M. Normand's instrument	271
Batten instruments: various arrangements of	272
Photographic apparatus	275
Automatic instruments	276
Description of Mr. Froude's automatic instrument	277
Simultaneous observations of behaviour of ships and character of waves much needed	280

CHAPTER VIII.

THE STRAINS EXPERIENCED BY SHIPS.

Necessity for careful study of subject... ..	282
Classification of principal strains	283
Longitudinal bending moments (hogging and sagging):—	
Due to unequal distribution of weight and buoyancy	284
Method of estimating bending moments	286
Curves of weight, buoyancy, loads and bending moments, construc- tion and uses of, with examples for typical ships	287
Bending moments due to longitudinal fluid pressure	293
Extreme cases of support for ships among waves	294
Corresponding bending moments for typical ships	297
Influence of pitching and 'scending upon longitudinal strains	301
Bending moments of ships ashore	302
Transverse strains experienced by ships when—	
Resting on the keel only in dock or ashore	304
Afloat in still water	306
Rolling among waves	307
Strains incidental to propulsion—	
By sails	309
By screws or paddles	311
Local strains, produced by—	
Concentrated load or support	312
Grounding: with special reference to iron ships	314
Loads on decks	316
Collision: with special reference to ramming	317
Propulsion	321

CHAPTER IX.

THE STRUCTURAL STRENGTH OF SHIPS.

	PAGE
Gradual development of structural arrangements	325
Features common to structures of all ships	326
Ultimate effect of longitudinal bending strains	327
Construction of "equivalent girder" sections	328
Principles of the strength of beams and girders	331
Application of these principles to longitudinal strength of ships	335
Influence of form, proportions, and local requirements upon the scantlings of ships	340
Longitudinal strength contributed by—	
Upper decks of ships	345
Bottoms below the bilges	347
Longitudinal framing and cellular construction	349
Skins and riders of ordinary wood ships	355
Skins of composite ships	357
Skins of diagonally built wood ships	358
Skins of iron and steel ships	359
Special arrangements of shallow-draught vessels	360
Maximum longitudinal strains of war ships	362
" " " of merchant ships	364
Provision of transverse strength	367
Strength of transverse frames or ribs in wood and iron ships	368
Partial bulkheads of iron ships	369
Transverse framing of ironclads and swift cruisers	370
Decks, beams and pillars as transverse strengtheners	372
Beam-knees and beam-end fastenings	374
Transverse bulkheads considered as strengtheners	376

CHAPTER X.

MATERIALS FOR SHIPBUILDING: WOOD, IRON, AND STEEL.

Remarkable progress of iron shipbuilding	379
Great increase in sizes and speeds of ships of late years	381
Iron ships superior to wood in the combination of lightness with strength	383
Weights of hull and carrying power of ships	384
Resistance of single pieces of wood and iron to tensile and compressive strains	385
Moduli of elasticity of iron and timber	391
Resistance of combinations of wood or iron to tensile and compressive strains	391
Modes of scarphing timbers and shifts of butts in wood ships	392
Butt and lap joints of iron plates or bars	395
Resistance to bending of wood and iron beams	397
Comparative durability of wood and iron ships	400
Corrosion of iron ships: how caused and prevented	406
Iron ships more easily built and repaired than wood ships	409

	PAGE
Cost of maintenance of wood and iron ships	412
Subdivision, a source of safety to iron ships	413
Fouling of bottoms of iron ships	415
Copper and other sheathings for ships' bottoms	417
Comparative wear of various metals in sea-water	419
Metal sheathing on wood ships	420
Copper sheathing on iron ships	420
Zinc sheathing for iron ships	422
Iron hulls in unarmoured war ships	424
Use of steel for shipbuilding:—	
Rapid progress in recent years	426
Earlier examples	427
Qualities of mild steel	427
Economical advantages of	429

CHAPTER XI.

THE RESISTANCE OF SHIPS.

Early theories of resistance	423
Resistance to direct and oblique motion of planes	435
Frictional resistance to motion of planes	437
Modern or stream-line theory: principle features of, for frictionless fluids	440
Frictional resistance experienced by ships	446
Eddy-making resistance	449
Wave-making resistance:—	
Mr. Scott Russell's theory	451
Professor Rankine's investigation	454
Mr. Froude's experimental researches	455
Limiting speeds for economical propulsion	459
Economical propulsion frequently not the governing condition in ship design	461
Recent tendencies in merchant-ship design	464
Resistance at very high speeds: torpedo-boats, &c.	466
Mr. Froude's system of model experiments:—	
Its practical advantages	469
Mathematical basis for scale of comparison	471
Observations of change of draught and trim for ships in motion	475
Resistance in a seaway	477
Air resistance	477

CHAPTER XII.

PROPULSION BY SAILS.

Arrangement of sail-plans: work of naval architect	480
Summary of facts as to velocities and pressures of winds	481
Classification of winds	485
Actual and apparent direction and velocity of wind relatively to sails	486

	PAGE
Case of ship running before wind	488
Case of ship drifting dead to leeward	488
Case of ship sailing on a wind	490
Ardency and slackness	492
Balance of sail	493
Plain sails for various rigs	494
Estimates for sail areas	495
Comparative sail-spreads in various types	497
Longitudinal distribution of sail and position of centre of effort	501
Stations and rakes of masts	505
Vertical distribution of sail	508
Sail-carrying power	509
Forms and proportions of obsolete and recent sailing ships	512
Forms and proportions of yachts	514

CHAPTER XIII.

STEAM PROPULSION.

Rapid development of steam navigation	515
Problem of steam-ship design	516
Measures of "horse-power" for marine engines	518
Principal types of marine engines :—	
Weights and rates of coal consumptions	523
Advantages of economy in coal consumption	525
Use of "forced draught"	527
Employment of the locomotive type of boiler	528
Fundamental principle of the action of propellers	530
Water-jet propeller and its applications	532
Paddle-wheels	538
Screw propellers :—	
Theoretical investigations of their action	544
Experiments with models	548
Various arrangements of, in ships	549
Augment of resistance, produced by	550
Influence of "wake" upon efficiency of	553
Comparative efficiency of single and twin-screws	555
Necessity for experimental trials of	557
Novel descriptions of	560
Efficiency as compared with paddles and jets	561
Estimates for power and speed of steam-ships :—	
Efficiency of marine engines	562
Efficiency of propellers	564
Admiralty coefficients of performance	566
Rankine's "augmented surface" method	570
Progressive steam trials and their uses	571
Estimates from model experiments	578
Steam-ship efficiency :—	
No universal standard possible	580
Special conditions of armoured ships	581

	PAGE
Russian circular ironclads	583
Russian yacht <i>Livadia</i> , and other types	586
Influence of increase in size upon economical propulsion	588
Torpedo-boats and swift launches	593
Expenditure of power in various classes	595

CHAPTER XIV.

THE STEERING OF SHIPS.

Different modes of steering	597
Ordinary and balanced rudders	598
Fluid pressure on rudders: causes and measures of	600
Special features of screw-ship steering	602
Force required at tiller-end: estimates of	607
Work to be done in putting a rudder over	610
Balanced rudders: advantages of	611
Steam and hydraulic steering apparatus	612
Turning effect of rudders	614
Conditions influencing readiness of ships to answer their helms	616
Initial motions of ships in turning	618
Motion in earlier stages of turning from a straight course	619
Modes of determining the path of a ship	620
Turning trials of <i>Thunderer</i>	621
Uniform turning motion	623
Drift-angles and their effects	624
Heeling in turning	627
Turning trials of war ships: deductions from recorded results of	630
Rules for forms and areas of rudders	637
Special rudders:—	
Twisted surfaces	642
Gumpel's and Lumley's	643
Bow rudders	644
White's rudder	645
Steering-screws and water-jets	646
Mechanical steering paddles	647
Auxiliary rudders	648
Steering blades	649
Steering by propellers:—	
In single-screw ships	650
Fowler's wheel	652
Twin-screws and other duplicate propellers	653
Manœuvring in a seaway	657

INDEX	659
--------------	-----

NAVAL ARCHITECTURE.

CHAPTER I.

THE DISPLACEMENT AND BUOYANCY OF SHIPS.

A SHIP floating freely and at rest in still water must displace a volume of water having a weight equal to her own weight. The truth of this fundamental condition may be easily demonstrated. Let Fig. 1 represent the ship (in profile view and athwartship section), WL being the surface of the water. If it is supposed that the water surrounding the ship becomes solidified, and that

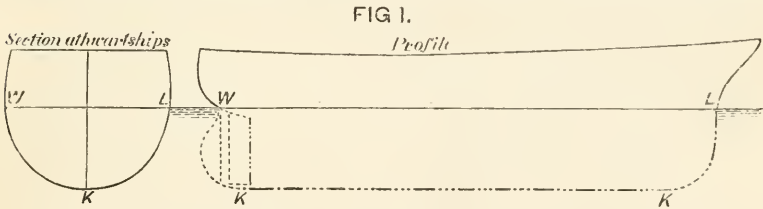

the ship is then removed, there will remain a cavity representing in form and volume the water displaced by the ship: this is termed the "volume of displacement" (or, shortly, the "displacement") of the ship, being represented in the diagrams by WKL. If the cavity is then filled up to the level of the surface WL with water of the same density as that in which the ship floated, and afterwards the surrounding water again becomes liquid, there will obviously be no disturbance or change of level in consequence of the substitution of the water for the ship. Therefore the total weight of water poured into the cavity—that is, the total weight of water displaced by the ship—must equal her weight.

This fundamental law of hydrostatics applies to all floating bodies, and is equally true of wholly submerged vessels floating at any depth as of ships of ordinary form, having only a portion of their volume immersed.

Ships which are of equal weight may differ greatly in form

and dimensions, and consequently the forms of their respective displacements will differ; but when they are floating in water of the same density, the volumes must be equal to one another, because the weights of the ships are equal. On the other hand, when a ship passes from water of one density to water of another density, say from the open sea to a river where the water is comparatively fresh, her volume of displacement must change, because the weight of water displaced must be the same in both cases. Under all circumstances the volume of displacement, multiplied by the weight per unit of volume of the water in which the ship floats, must equal the weight of the ship. It is usual to express the volume in cubic feet, and for sea-water to take 64 lbs. as the weight of a cubic foot: so that the weight of the ship in tons multiplied by thirty-five gives the number of cubic feet in the volume of displacement when she floats in sea-water.

At every point on the bottom of a ship afloat, the water pressure acts perpendicularly to the bottom. This normal pressure at any point depends upon the depth of the point below the water surface; and it may be regarded as made up of three component pressures. First, a vertical pressure; second, a horizontal pressure acting athwartships; third, a horizontal pressure acting longitudinally. Over the whole surface of the bottom a similar decomposition of the normal fluid pressures may be made; but of the three sets of forces so obtained, only those acting vertically are important in a ship at rest. The horizontal components in each set must obviously be exactly balanced amongst themselves, otherwise the ship would be set in motion either athwartships or lengthwise. The sum of the vertical components must be balanced by the weight of the ship, which is the only other vertical force; this sum is usually termed the "buoyancy;" it equals the weight of water displaced, and the two terms "buoyancy" and "displacement" are often used interchangeably.

The total weight of a ship may be subdivided into the "weight of the hull," or structure, and the "weight of lading." The latter measures the "carrying power" of the ship, and is therefore frequently termed the "useful displacement." Useful displacement for a certain degree of immersion is simply the difference between the total displacement and the weight of the hull: so that any decrease in the weight of hull leads to an increase in the carrying power. If the ship is a merchantman, savings on the hull enable the owner either to carry more cargo in a vessel of a specified size or else to build a smaller vessel to carry a specified cargo. If the ship is a man-of-war, such savings on the hull

render possible increase in the offensive or defensive powers, or in the coal supply, engine power, or speed; or else enable certain specified qualities to be obtained on smaller dimensions than would otherwise be practicable. Hence appears the necessity for careful selection of the best materials and most perfect structural arrangements, in order that the necessary strength may be secured in association with the minimum of weight. It is in this direction that all recent improvements in shipbuilding have tended; the use of iron hulls instead of wood has greatly facilitated progress, and further advances are now being made by the substitution of steel for iron. These improvements in ship construction are described in Chapter X.

Having given the draught of water to which it is proposed to immerse a ship, the volume of her immersed part determines the corresponding displacement, and this displacement can be calculated with exactitude from the drawings of the ship. This is the method adopted by the naval architect; but any details of the method would be out of place here. At the same time an approximate rule by which an estimate of the displacement of the ship may be rapidly made may have some value. Assuming that the length of the ship at the load-line is known (say L), also the breadth extreme (B), and the mean draught (D), the product of these three dimensions will give the volume of a parallelepipedon. This may be written:—

$$\text{Volume of parallelepipedon} = V \text{ (cubic feet)} = L \times B \times D.$$

The volume of displacement may then be expressed as a *percentage* of the volume (V) of the parallelepipedon; and for the undermentioned classes of ships, the following rules hold:—

Classes of Ships.	Displacement equal to Percentage of Volume (V).
1. Fast steamships, such as her Majesty's yachts } or the Holyhead packets }	43 to 46 per cent.
2. Swift steam-cruisers of Royal Navy (<i>Inconstant</i> } and <i>Volage</i> classes); corvettes and sloops . }	46 to 52 per cent.
3. Gun-vessels of Royal Navy; merchant steamers } (common forms) }	55 to 60 per cent.
4. Old classes of unarmoured steam line-of-battle } ships and frigates in Royal Navy }	50 to 55 per cent.
5. Early types of ironclads in Royal Navy } (<i>Warrior</i> and <i>Minotaur</i> classes) }	55 per cent.
6. Modern types of rigged ironclads, with moderate } proportions of length to breadth }	60 to 62 per cent.
7. Mastless sea-going ironclads (<i>Devastation</i> class); } cargo-carrying steamers of moderate speed . }	65 to 70 per cent.

To these approximate rules for steamers, a few corresponding rules for sailing ships may be added. In the obsolete classes of war-ships the displacements ranged from 40 per cent. of the volume of the parallelopipedon, in brigs, to 45 per cent. in frigates and 50 per cent. in line-of-battle ships. It is to be observed that these vessels had comparatively deep keels and false-keels, especially the smaller classes; which circumstance tended to make their "co-efficients of fineness" (or percentages) appear smaller than they would otherwise have done. In modern racing yachts, with very deep keels, the percentages vary from 22 to 33; in modern merchantmen the percentages frequently lie between 55 and 60.

These approximate rules cannot be substituted for exact calculations of displacement; they are of service only in enabling a fairly accurate estimate to be made when the principal dimensions and character of a ship are known.

For example, take a wood-built corvette of the *Encounter* class in the Royal Navy. Her dimensions are:—Length = $L = 220$ feet; breadth = $B = 37$ feet; mean draught = $D = 15\frac{3}{4}$ feet.

Hence for parallelopipedon, volume is given by

$$V = L \times B \times D = 220 \times 37 \times 15\frac{3}{4} = 128,205 \text{ cubic feet.}$$

By rule 2 in foregoing table, taking the upper limit, as these vessels have only moderate speed—

$$\begin{aligned} \text{Displacement (in cubic feet)} &= 52 \text{ per cent. of } V \\ &= \frac{52}{100} \times 128,205 = 66,660 \text{ cubic feet.} \end{aligned}$$

There are 35 cubic feet of sea-water to the ton; hence

$$\text{Displacement (in tons)} = 66,660 \div 35 = 1904 \text{ tons.}$$

The displacement of the class (see Navy List) is about 1930 tons. Being built of wood, the hull of such a vessel will weigh about one-half the displacement; the carrying power being consequently about 950 tons. This is approximately the total weight available, therefore, in a vessel of the *Encounter* class, for engines, boilers, coals, stores, equipment, and armament; and the disposal of this available weight in the manner that will secure the greatest efficiency for the service intended is a matter requiring careful consideration.

As another example, take the case of one of her Majesty's armoured frigates, masted and rigged, such as the *Alexandra*, the most powerful ship of that class yet completed. Her dimensions

are:—Length = $L = 325$ feet; breadth = $B = 63\frac{2}{3}$ feet; mean draught = $D = 26\frac{1}{4}$ feet.

Hence

$$V = L \times B \times D = 325 \times 63\frac{2}{3} \times 26\frac{1}{4} = 543,156.$$

Also, by rule 6 in the table—

$$\left. \begin{array}{l} \text{Displacement} \\ \text{(approximate)} \end{array} \right\} = 60 \text{ to } 62 \text{ per cent. of } V = 61 \text{ (say)} \\ = \frac{61}{100} \times 543,156 = 331,325 \text{ cubic feet.}$$

$$\text{And displacement in tons} = 331,325 \div 35 = 9465 \text{ tons.}$$

The actual displacement is 9492 tons; so that the approximation is fair.

In iron-built ships of the *Alexandra* type, about 40 per cent. of the displacement is required for the hull; so that 60 per cent.—or about 5600 tons—would be a fair approximation to the total carrying power, and this weight is what the designer has in his power to distribute as he thinks best, over armour, guns, machinery, coals, and all other parts of the equipment. These examples will probably suffice to show the reader unfamiliar with the exact processes for calculating the displacement of ships how he may approximate to that displacement.

The percentages stated in the foregoing table are technically known as “coefficients of fineness,” expressing, as they do, the extent to which the immersed part of the ship is “fined” or reduced from the parallelopipedon. As measures of the comparative fineness of form of any two ships, it is, perhaps, more satisfactory to take the coefficients expressing the ratios of the respective volumes of displacement to the volumes of the right cylinders described upon the greatest immersed athwartship sections of the ships, and having lengths equal to the lengths of the ships along the water-lines. But the determination of these last-named coefficients involves the use of the drawings of the ships in order to determine the areas of the immersed midship sections; and they are chiefly of use to the naval architect.

Ships vary in their draught of water and displacement as the weights on board vary, and in cargo-carrying merchant vessels this variation is most considerable, their displacement without cargo, coals, or stores, often being considerably less than one-half of the load displacement. In ships of war the variation in displacement is not usually so great, but even in them the aggregate of consumable stores reaches a large amount, and when they are out of the ship, she may float 2 or 3 feet lighter

than when fully laden. Naval architects have devised a plan by which, without performing a calculation for every line at

which a ship may float, it is possible to ascertain the corresponding displacement by a simple measurement. Fig. 2 illustrates one of the "curves of displacement" drawn for this purpose; it is constructed as follows. The displacements up to several water-lines are obtained by direct calculation from the drawings of the ship, in the manner before mentioned. Then a line AB is drawn, the point A representing the under side of the keel, and the length AB representing the "mean draught" of the ship when fully laden; this mean draught being half the sum of the draughts of water forward and aft. Through B a line BC is drawn at right angles to AB , the length BC being made to represent, to scale, the total displacement of the ship when fully laden: an inch in length along BC representing, say, 1000 tons of displacement. Suppose the displacement to have been also calculated up to another water-line (represented by DE in the diagram) parallel to and at a known distance below the load-line (BC). Then on DE a length is set-off representing this second displacement on the same scale as was used for BC . Similarly the lengths FG , HK , and so on, are determined, and finally the curve $CEG \dots A$ is drawn through the ends of the various ordinates. When this curve is once drawn, it becomes available to find the approximate displacement for any draught of water at which the ship may float, supposing that she does not very greatly depart in *trim* from that at which she floats when fully laden.* For instance, suppose the mean draught for which the displacement is required to be 4 feet lighter than the load-draught. Set down Bx representing the 4 feet, on the same scale on which AB represents the mean load-draught. Through x draw xy perpendicular to AB to meet the curve, and the length xy (on the proper scale) measures the displace-

FIG 2.

* By "trim" the naval architect means the *difference in draught* at the bow of a ship from that at the stern.

ment at the light draught. This brief explanation will doubtless render obvious the great practical usefulness of curves of displacement, which always form part of the calculations attached to the designs of ships.

Another problem that frequently occurs is the determination of the increased immersion which will result from putting a certain weight on board a ship when floating at a known draught, or the decreased immersion consequent on removing certain weights. Here again the naval architect resorts to a graphic method in order to avoid numerous independent calculations. The diagram, Fig. 3, represents a "curve of tons per inch immersion;" the horizontal measurement from the base-line AB representing (on a certain scale) the number of tons which would immerse the ship one inch when she is floating at the draught corresponding to the ordinate along which the measurement is made. The construction of this curve is very similar to that of the curve of displacement in Fig. 2, the successive points on the curve being found for the equidistant water-lines, BC, DE, FG, &c., by direct calculation from the drawings of the ship; and the length of the ordinate xy determining the number of tons required to immerse the ship one inch when floating at any mean draught, Ax .

In this case also it is to be understood that at the various mean draughts considered there are no considerable departures in trim from that of the fully laden ship.

It will be observed in the diagram that the upper part of the curve of tons per inch is very nearly parallel to the base-line AB; this arises from the well-known fact that, in the neighbourhood of the deep load-line of ships of ordinary form, the sides are nearly upright, and there is little or no change in the area of the horizontal sections. For all practical purposes, in most ships, no great error is involved in assuming that twelve times the weight which would sink the ship one inch below her load-line will sink her one foot, or that a similar rule holds for the same extent of lightening from the load-draught. In

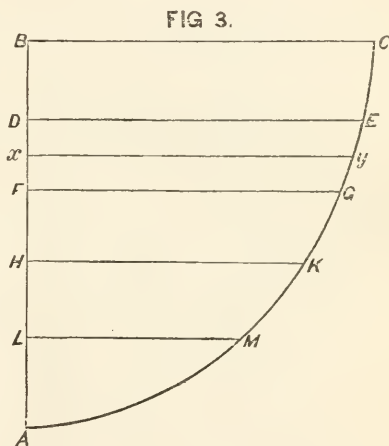

fact, it is very common to find this rule holding fairly for 2 feet on either side of the fully laden water-line. A rule which gives a fair approximation to the tons per inch immersion at the load-line, in terms of the length and breadth of the ship, has therefore considerable value. Using the same symbols as before, viz. :—

$$\begin{aligned} \text{Length of the ship at the load-line} &= L \text{ (feet),} \\ \text{Breadth extreme} \quad \quad \quad \quad \quad &= B \quad \quad \quad \quad \quad \end{aligned}$$

we should have,

$$\left. \begin{array}{l} \text{Area of circumscribing} \\ \text{parallelogram} \end{array} \right\} = L \times B = A \text{ (square feet).}$$

And then the following rules express, with a considerable amount of accuracy, the number of tons required to immerse or emerse the ship one inch when floating at her load draught :—

- | | Tons per Inch. |
|--|--|
| 1. For ships with fine ends | $= \frac{1}{800} \times A$. |
| 2. For ships of ordinary form (including probably the
great majority of vessels). | $\left. \begin{array}{l} \\ \end{array} \right\} = \frac{1}{560} \times A$. |
| 3. For ships of great beam in proportion to length and
ships with bluff ends | $\left. \begin{array}{l} \\ \end{array} \right\} = \frac{1}{500} \times A$. |

One or two examples of these rules may prove useful. The *Invincible* class of the Royal Navy are ships coming under rule 2, being ships of ordinary form. Their dimensions are :—Length = $L = 280$ feet; breadth = $B = 54$ feet.

$$\left. \begin{array}{l} \text{Area of circumscribing} \\ \text{parallelogram} \end{array} \right\} = A = 280 \times 54 = 15,120 \text{ sq. ft.}$$

$$\therefore \text{ Tons per inch at load-line} = \frac{1}{560} \times 15,120 = 27 \text{ tons.}$$

This is nearly exact for these vessels.

As a second example, take her Majesty's ship *Devastation*, a short, broad vessel, coming under rule 3. Her dimensions are :—Length = $L = 285$ feet; breadth = $B = 62\frac{1}{4}$ feet.

$$\text{Area} = A = 285 \times 62\frac{1}{4} = 17,740 \text{ square feet.}$$

$$\text{Tons per inch at load-line} = \frac{1}{500} \times 17,740 = 35\frac{1}{2} \text{ tons (nearly).}$$

The actual "tons per inch" for this ship is about $36\frac{1}{2}$ tons.

The second rule in the foregoing table is that which should be applied in most cases.

It is easy to see how the curves of tons per inch, and the curves of displacement constructed for the case of ships floating in sea-water, may be made use of in order to determine the change of draught produced by the passage of a ship into

a river, or estuary, or dock, where the water is comparatively fresh. For example, sea-water weighs 64 lbs. per cubic foot, whereas in one of the London docks the water weighs about 63 lbs. per cubic foot—or $\frac{1}{64}$ part less than sea-water. Since the total *weight* of water displaced by the ship must remain constant, it is only necessary to make the following corrections:—

Difference between weight of sea-water and river-water for the volume immersed up to the draught at which the ship floats at sea

$$= \frac{1}{64} \times \text{weight of ship} = \frac{1}{64} W.$$

Tons per inch immersion at this draught in river-water

$$= \frac{63}{64} \text{ tons per inch for sea-water} = \frac{63}{64} T.$$

∴ Increase in draught of water when ship floats in river-water

$$= \frac{1}{64} \times W = \frac{63}{64} T = \frac{W}{63 T} \text{ (inches).}$$

For any other density of water than that assumed above, the correction would be made in a similar manner. As a numerical example, take a ship having the following particulars:—Weight = $W = 6000$ tons ; tons per inch at load-draught in sea-water = $T = 30$.

$$\left. \begin{array}{l} \text{Increased draught on entering London} \\ \text{docks, as compared with her draught} \\ \text{at the Nore} \end{array} \right\} = \frac{6000}{63 \times 30} = 3\frac{11}{63} \text{ in.}$$

The draught being observed when the vessel is about to leave the sea, the curves of displacement and tons per inch will furnish the corresponding values of W and T in the foregoing expressions.

The converse case, where a ship, on passing from a dock or river to the sea, floats at a less draught, need not be discussed. It is, however, of considerable importance to merchant ships, exercising an appreciable effect upon their freeboard when deeply laden.

The buoyancy of a ship has already been defined, and shown to be measured by the displacement up to any assigned water-line. “Reserve of buoyancy” is a phrase now commonly employed to express the volume, and corresponding buoyancy, of the part of a ship not immersed, but which may be made watertight, and which in most vessels would be inclosed by the upper deck, although in many cases there are watertight inclosures above that deck—such as poops, forecastles, breastworks, &c. The under-water, or immersed, part of a ship contributes the buoyancy ; the out-of-water part the reserve of buoyancy, and the ratio

between the two has a most important influence upon the safety of the ship against foundering at sea.

The sum of the two, in short, expresses the total "floating power" of the vessel, and the ratio of the part which is utilised to that in reserve is a matter requiring the most careful attention. This fact has come into prominence recently in the discussion of questions of lading and free-board, as affecting the safety of merchant ships.

In Figs. 4-9 are given illustrations of the very various ratios which the reserve of buoyancy bears to the volume of displacement in different classes of ships. As this is only a matter of ratio, a box-shaped form has been employed instead of a ship-shaped, and in all the cases the volume of displacement is the same, so that the out-of-water portions can be compared with one another as well as with the displacement.

Fig. 4 represents the condition of low-free-board American monitors, such as the *Canonicus* or *Passaic*, which were employed on the Atlantic coast during the

Civil War. The upper decks of these vessels are said to have been between 1 and 2 feet only above water; their reserve of buoyancy was only about 10 per cent. of the displacement.

FIG 4.

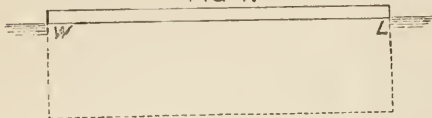

FIG 5.

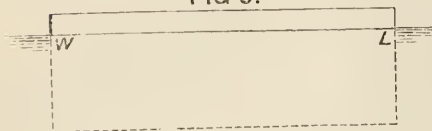

FIG 6.

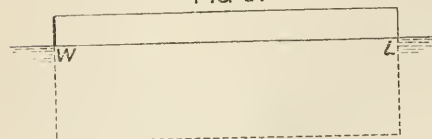

FIG 7.

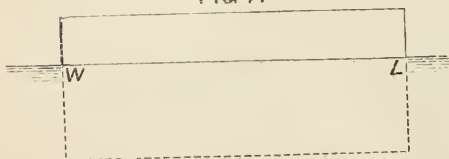

FIG 8.

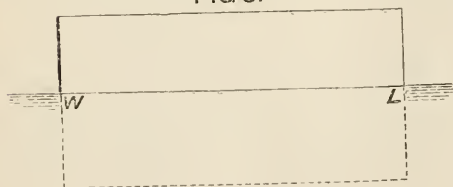

FIG 9.

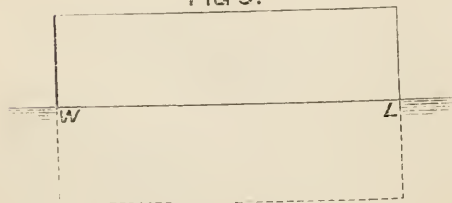

Fig. 5 represents the condition of the American monitor *Miantonomoh*, with a reserve of buoyancy of about 20 per cent. of the displacement; this approximately shows her state when she crossed the Atlantic in 1866, but all openings on her upper deck, which was about 3 feet above water, were carefully closed or caulked.

Fig. 6 represents the *Cyclops* class of breastwork monitors in the Royal Navy. The upper decks of these vessels are only about the same height above water as that of the *Miantonomoh*, but, by means of an armoured breastwork standing upon the upper deck, the reserve of buoyancy is increased to 30 per cent. of the displacement.

Fig. 7 represents the *Devastation* class, in which the reserve of buoyancy is 50 per cent. of the displacement.

Fig. 8 represents armoured frigates of high freeboard—such as the *Sultan* or *Hercules*—of the Royal Navy, in which the reserve of buoyancy reaches 80 or even 90 per cent. of the displacement.

Fig. 9 represents ships of high freeboard and fine under-water form—typified by her Majesty's ship *Inconstant*—in which the reserve of buoyancy is equal to, or even greater than, the displacement.

So much for vessels of war. As regards merchant ships, the diversity of practice in loading renders it difficult to lay down any rule; there seems, however, a concurrence of opinion in fixing the minimum reserve of buoyancy at from 20 to 30 per cent. of the displacement, varying it according to the season of the year, the character of the cargo, extent of the voyage, &c. But, perhaps, the greatest difficulty met with in attempting to apply any such rule to merchant ships is found in the selection of those parts of the ships which shall be regarded as contributing to the reserve of buoyancy. "Spar-decks," "deck-houses," "inclosed poops and forecastles," &c., are very commonly built of comparatively slight scantlings, above the upper deck proper; and the assignment of proper values to these erections in estimating the reserve of buoyancy has given rise to much discussion, out of which no practical rule for guidance has come which can command general acceptance.

Submarine vessels, such as have been built or proposed for use in war, furnish examples differing from ordinary ships. They are intended at times to be wholly submerged, and then have no "reserve of buoyancy," using that term in the same sense as above. Such vessels, of course, require to be arranged

so that the operators within them may control the vertical motions, either rising to the surface when necessary or submerging the vessel to any desired depth. For all practical purposes, water may be treated as if it were incompressible; at any depth in which submarine vessels would work, a cubic foot of sea-water may be taken as weighing 64 lbs. The weight of a vessel and all its contents may also be assumed to be practically a constant quantity during the period of one submersion, and, as already explained, the displacement of the vessel, when it floats at rest at any depth, must always equal the weight. To produce vertical motions in such a vessel, it is therefore necessary to give the operator the power of *slightly varying the displacement*. If he can virtually decrease the volume of displacement, below that corresponding to the total weight, the vessel must sink; but if, when the desired depth is reached, he can gradually restore the displacement to equality with the weight, no further sinking will take place, nor will the vessel have any tendency to rise. Before she can rise, the volume of water displaced must by some means be made to exceed that corresponding to the weight; directly that condition is fulfilled, the vessel begins to rise. A very simple arrangement suffices to give the operator the necessary control. For instance, conceive that a small cavity is formed in the bottom of the vessel, and that, when this cavity is about *half full* of water, the total displacement of the vessel, when entirely submerged, just corresponds to the total weight. The other half of the cavity may be then kept filled with compressed air, which is in communication with an air chamber in the interior of the vessel. The air in the air chamber would be compressed sufficiently to have a considerable excess of pressure over that corresponding to the maximum depth of immersion at which the vessel is to be employed. When the compressed air is withdrawn from the upper half of the cavity, by an apparatus worked within the vessel, the water rises into the vacated space, the volume of displacement becomes decreased by that space, and is therefore less than will balance the weight; as a result, the vessel sinks. The desired depth being reached, compressed air stored within the vessel may be made use of to force the water once more from the upper half of the cavity, thus restoring equality between the weight and displacement; the vessel then remains at that depth. Lastly, when it is required to rise, by means of compressed air the water is wholly expelled from the cavity; the displacement then exceeds the weight, and consequently the

vessel rises. Other agencies may be employed to effect these results; but the principle is the same for all—the operator must have the power of virtually increasing or decreasing the volume of displacement if the weight remains practically constant. By means of detachable ballast the weight can be decreased; and the power of ascending rapidly to the surface in case of accident can thus be secured. This is a very desirable feature in submarine vessels, but does not take the place of the controlling apparatus above described.

The foregoing remarks imply that the submarine vessel has no onward motion, when she is made to move vertically; but, in practice, this condition is not usually fulfilled, and the propelling power itself has been made available for producing or controlling the vertical motion, by means of a horizontal rudder worked by the operator within the vessel. In the Whitehead torpedo, a similar rudder, governed automatically, is employed to keep the torpedo at the desired depth below the surface. Another plan, illustrated in a model to be seen in the Naval Museum at the Louvre, consists in giving vertical motion to the submerged vessel by means of a small screw-propeller, worked by a vertical axis, and placed above the vessel. This screw is an auxiliary to air chambers like those above described, and its chief purpose appears to be the diminution of the vertical oscillations which the other appliances may produce about the position which it is desired to maintain. It will be obvious that if a vessel acquires a considerable velocity while descending to any assigned depth, as she may do if the operation is performed quickly, she will probably be carried much beyond that depth, even though her original displacement be restored by expelling water from the balancing cavity. Conversely, if to make her rise again still more water be expelled, there is a risk of too great a vertical motion being produced; and so oscillatory movements may take place about the desired depth. A manœuvring screw such as the French vessel has, is one of the simplest and most effective means conceivable for extinguishing these oscillations; and a screw of similar character, if power were available, might be made to give all necessary vertical motion to a vessel, although this would be a less economical arrangement than the air chamber. It will be evident that the risks incidental to service in these vessels can only be minimised by the greatest care in management as well as in design.

Ships founder when the entry of water into the interior causes a serious and fatal loss of floating power. There are two cases

requiring notice. The first, and less common, where the bottom of the ship remains intact, but the sea breaks over and "swamps" the vessel. The second, that in which the bottom is damaged or fractured, and water can enter the interior, remaining in free communication with the water outside. Damage to the underwater portion of the skins of ships is by far the most fruitful source of disaster; but many ships founder in consequence of being swamped, seas breaking over them, and finding a passage down through the hatchways into the hold.

The older sailing brigs of the Royal Navy are believed by many competent authorities to have been specially exposed to this danger. Very many of them were lost at sea; and their loss was believed to have resulted from the lowness of their freeboard, the height of their bulwarks, and the insufficiency of the "freeing scuttles" in the top-sides to clear rapidly the large masses of water which lodged on the decks. In consequence, water accumulated, passed into the interior, and swamped the ships. The case of the steam-ship *London* furnishes another illustration. She is said to have been lost in consequence of a very heavy sea having swept away the covering of the engine hatchway, and left open a large aperture, down through which the water poured, putting out the fires, and leaving the ship a log on the water. Other seas washing over the unfortunate vessel completed the disaster, and she gradually sank. The United States monitor *Weehawken* also appears to have been lost in this manner. While forming part of the blockading squadron, and lying at anchor off Charleston with her hatchway forward uncovered, the weather being comparatively fine, a sea broke on the deck, poured down the open hatchway, and caused the vessel to sink rapidly—it is said in three minutes—her extreme lowness of freeboard and small reserve of buoyancy conducing to this end. Still another, and slightly different, case in point may be found amongst the vessels engaged in the timber trade. It has been customary to load these ships very deeply, and often to carry large deck cargoes; thus interfering with the efficient working of the ships. Meeting with heavy weather, and being only partially under control on account of the deck cargoes, these vessels frequently ship large quantities of water, becoming "water-logged," and utterly unmanageable, even if they do not sink.

The condition of a water-logged ship naturally leads to the remark, that in any ship the maximum quantity of water that can enter the interior may or may not suffice to sink her, ac-

ording as it is greater or less in weight than the reserve of buoyancy which the ship possesses. The maximum quantity of water that can enter the interior is determined by the *unoccupied space*: for to space which is already occupied by any substances—cargo, coals, engines, &c.—the water can obviously find no access. If the cargo be, like timber, very light, occupying a very large portion of the internal space, then it may happen that the total volume of the space unoccupied is less than that of the reserve of buoyancy, and the ship remains afloat; but this is not the common case, and if a vessel becomes swamped, and the sea finds access into all parts of the interior through the hatchways, she will most probably founder. Properly constructed and well-laden vessels are not, however, likely to founder in this fashion. Their hatchways and openings in the decks are carefully secured, and protected by high coamings and covers;

FIG 10.

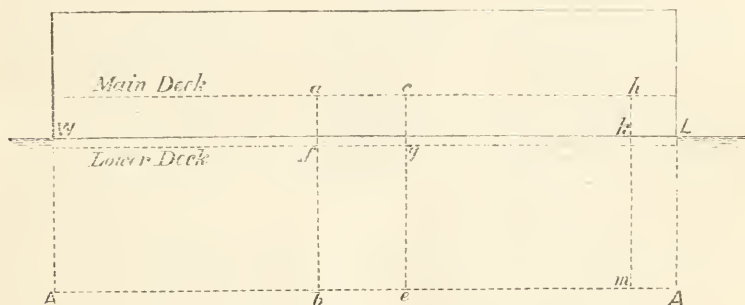

while the interior is so subdivided into compartments, especially in iron ships, that, if a sea breaks on board, and finds its way down a hatch, it does not gain free access from the space thus entered to all other parts of the interior. Free water which passes thus into a ship must considerably affect her behaviour in a seaway, although it may not jeopardise her safety: this case is considered in Chapter VI.

Turning next to the case of the ship of which the skin is penetrated below water, it is needless to cite examples of the possibly serious nature of such an accident. Very many illustrations will at once occur to the mind of every reader; this being a very common source of loss now that iron is the material generally used in building merchant ships. The causes of the under-water damage may be various—such as accidental collision, local wear and tear, grounding, ramming, torpedo explosions, &c.—but in all cases water can enter the ship, and this water

remains in *free* communication with the water outside. So long as that communication is maintained, water will continue to pass into the ship until either it can find access to no further space or has entered in such quantities as to exceed the reserve of buoyancy, when the vessel sinks.

A simple illustration will render these statements clear. Take a box-shaped vessel, such as in Figs. 10 and 11, and suppose a hole to be broken through the skin under water. The water at once passes into the interior in quantities depending upon the area of the hole and the depth it is below the water-level. A very simple rule approximately expresses the initial rate of inflow.

FIG 11.

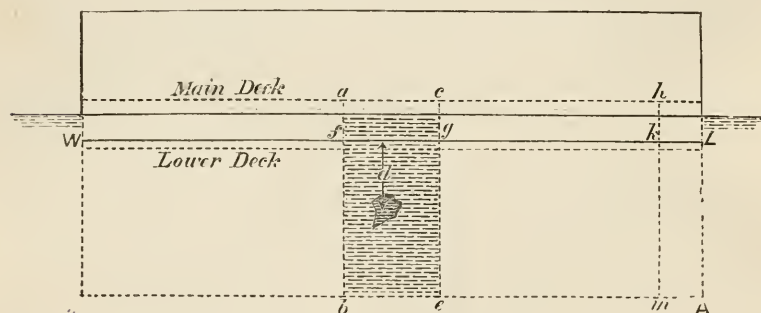

Let A = area of the hole (in square feet).

„ d = the depth below water in feet (taken about the centre of the hole will be near enough for practical purposes).

Then, if v = velocity of inflow of the water in feet per second,

$$v^2 = 64 d \text{ (approximately); and } v = 8\sqrt{d};$$

so that, immediately after an accident, the volume of water passing into the vessel in each second

$$= 8\sqrt{d} \times A \text{ (cubic feet).}$$

Suppose, for example, the hole is 2 square feet in area, and has its centre 12 feet under water :

$$v = 8\sqrt{12} = 27\frac{3}{4} \text{ feet per second.}$$

$$\text{Water flowing in per second} = 27\frac{3}{4} \times 2 = 55\frac{1}{2} \text{ cubic feet.}$$

If the vessel floats in sea-water,

$$\text{Tons of water flowing in per second} = 55\frac{1}{2} \div 35 = 1.58.$$

Similarly, for any other depth or area of hole in the bottom

of a ship, this rule will enable the rate of inflow to be determined very nearly.

Reverting to Fig. 10, it is obvious that, if the water can find free access to every part of the interior—which would be true if there were no partitions forming watertight compartments—the ship must sink: unless the power of her pumps is sufficient to overcome the leak; or some means is devised for checking the inflow, by employing a sail, or a mat, or some other “leak-stopper;” or the total unoccupied space in the interior is less than the reserve of buoyancy, a condition not commonly fulfilled. A consideration of the preceding formula for the rate of inflow will show that it is hopeless to look alone to the pumps to overcome leaks that may be caused by collision, ram attacks, or torpedo explosions; the area of the holes broken in the skin admitting quantities of water far too large to be thus dealt with.* Hence attention is directed to two other means of safety: the first, minute watertight subdivision of the interior of the ship, to limit the space to which water can find access; the second, the employment of leak-stoppers, which can be hauled over the damaged part, and made to stop or greatly reduce the rate of inflow. This latter is a very old remedy, Captain Cook having used a sail as a leak-stopper during his voyages, and many ships having been saved by similar means. It has acquired renewed importance of late, and various inventors have proposed modifications of the original plan, but all these are based upon the old principle of “stopping” the leak. Such devices are not embodied in the structure or design of the ship, but form simply part of her equipment; whereas watertight subdivision is a prominent feature in the structure of a properly constructed modern iron ship. It will be well, therefore, to sketch some of its leading principles. In doing so, we shall, for the sake of simplicity, make use of box-shaped vessels for purposes of illustration; but the conclusions arrived at will, in principle, be equally applicable to less simple forms, like those of ships.

There are three main systems of watertight subdivision: (1) by vertical athwartship bulkheads; (2) by longitudinal bulkheads; (3) by horizontal decks or platforms. Besides these there is the very important feature of construction known as the “double bottom,” the uses of which will be described further

* For a full discussion of this point see a paper “On the Pumping Arrangements of War Ships,” contributed by

the author to the *Journal* of the Royal United Service Institution (1881).

on. In Figs. 10 and 11 the hole in the skin, admitting water to the hold, is supposed to lie between two transverse bulkheads (marked *ab* and *ce*) which cross the ship and form watertight partitions rising to some height above the load-draught line (WL) and terminating at a deck marked "Main Deck." The great use of these bulkheads will be seen if attention is turned to Fig. 11, which represents the condition of the box-shaped vessel after her side has been broken through. The vessel has sunk deeper in the water than when her side was intact; and it is easy to determine what the increase in draught has been when one knows the volume (*fgeb*, in Fig. 10) of the damaged compartment, as well as the volume in that space which is occupied by cargo, or machinery, or other substances. To simplify matters, suppose this compartment to be empty; and assume the length *ac* to be one-seventh of the total length AA: then the volume *fgeb* will be about one-seventh of the total displacement; and when this compartment is bilged and filled with water up to the height of the original water-line WL, one-seventh of the original buoyancy will be lost. In fact, the compartment between the bulkheads no longer *displaces* water; in it the water-level will stand at the height of the surface of the surrounding water; and since the weight of the ship remains constant, the lost buoyancy must be supplied by the parts of the ship lying before and abaft the damaged compartment. For this reason we must have—

$$\begin{aligned} \frac{6}{7} \text{ original water-line area} \times \text{increase in draught} \\ &= \frac{1}{7} \times \text{displacement} \\ &= \frac{1}{7} \times \text{original water-line area} \times \text{original draught.} \\ \text{Increase in draught} &= \frac{1}{6} \text{ original draught.} \end{aligned}$$

This very simple example has been worked out in detail because it illustrates the general case for ship-shape forms. The steps in any case are:—

(1) The estimate of loss of buoyancy due to water entering a compartment; this loss being equal to the part of the original displacement which the damaged compartment contributed, less the volume in the compartment occupied by cargo, &c.

(2) The estimate of the increased draught which would enable the still buoyant portions of the vessel to restore the lost buoyancy if the entry of water were confined to the damaged compartment.

And to these, in practice, must be added—

(3) The change of trim (if any) resulting from filling the damaged compartment.

Reverting to Figs. 10 and 11, it will be obvious that, if the transverse bulkheads ab and ce did not rise above the original water-line WL , more than one-sixth of the original draught, they would be useless as watertight partitions; because, when the compartment was bilged, their tops would be under water before the increase of draught had sufficed to restore the lost buoyancy. And when their tops are under water (unless the deck at which the bulkheads end forms a watertight cover to the compartment), the water is free to pass over the tops, or through hatchways and openings in the deck, into the adjacent compartments, thus depriving them also of buoyancy, and reducing the ship to a condition but little better than if she had no watertight partitions in the hold. Fig. 12 illustrates this serious defect. The main deck at which the transverse bulkheads ab and ce end is lower than in Figs. 10 and 11, all other conditions remaining un-

FIG. 12.

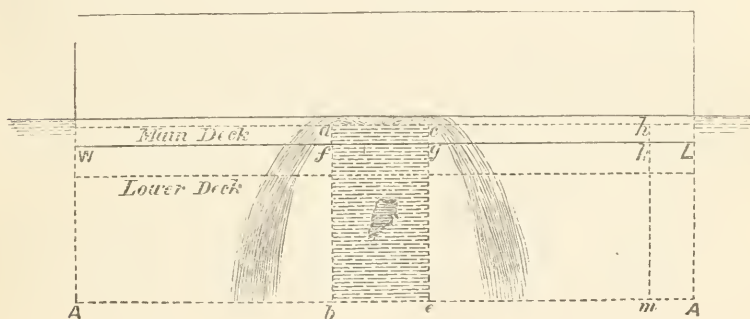

changed; and consequently, when the compartment is bilged, the water can pour over the tops of the bulkheads into the spaces before and abaft.

Hence this practical deduction. Watertight transverse bulkheads can only be efficient safeguards against foundering when care is taken to proportion the heights of their tops above the normal load-line to the volumes of the compartments; or else to make special provisions for preventing water from passing into adjacent compartments by means of watertight plating on the decks at which the bulkheads end, in association with watertight covers or casings to all hatchways and openings in the decks.

A vessel would ordinarily be considered very well subdivided if she would keep afloat with any *two* compartments filled simultaneously. This was the recommendation of the council

of the Institution of Naval Architects in 1867; but in the vessels of the Royal Navy it is not unusual to find the subdivision so minute that from three to six of the largest compartments may be simultaneously filled, without bringing the tops of the bulkheads under water, or allowing water to pass into compartments adjacent to those filled.

In iron or steel merchant ships efficient watertight subdivision is commonly wanting: the consequent risk being accepted rather than the interference with stowage of the hold which might result, in some cases, from the multiplication of transverse bulkheads. Sailing ships even of the largest size commonly have but one bulkhead near the bow; steamers are as a rule somewhat better off, and in many of the largest passenger steamers the subdivision is carried out thoroughly, transverse and longitudinal bulkheads as well as decks being utilised as watertight partitions. Efficient watertight subdivision is required by the Admiralty in all merchant steamers placed upon the official list, the essential condition being that the ships shall remain afloat in still water with any one compartment thrown open to the sea. It is a matter for congratulation that shipowners and shipbuilders are uniting in this development of watertight subdivision in our merchant ships, the Admiralty condition being much more than satisfied in a large and increasing number of ships.

The midship compartments of a ship are usually the largest, and claim most attention; but those near the extremities are also important, because, although their volume may be small, when they are filled they cause a considerable *change of trim*. Reverting once more to our box-shaped vessel in Fig. 10, instead of supposing an empty midship compartment equal to one-seventh of the length to be filled, and to cause a loss of one-seventh of the buoyancy, let it be supposed that a compartment only half as long and half as large at one end (shown by $mkLA$ in the diagram) is filled. The increase in the mean draught due to this accident would be only one-thirteenth of the original draught, but the trim would be altered very considerably (as shown in Fig. 13); and the top of the bulkhead hkm , although as high as those amidships, would be put under water by the change of trim. Consequently, unless the main deck is made watertight as far aft as the bulkhead hm , this very small compartment forward might, from its influence on the trim, be large enough to sink the ship; for when it is filled, if the deck does not form a watertight top to it, the water will pass over (at h) into the next compartment, the bow will gradually settle deeper and

deeper, and at last the vessel will go down by the head. It will be in the recollection of many readers that ships which founder very commonly settle down finally either by the head or the stern, and the foregoing simple illustration will furnish an explanation of some such occurrences.

It should be added that the assumptions made in the box-shaped vessel are fairly representative of actual ships. For example, in her Majesty's ship *Devastation*, if one of the large compartments amidships were filled, the ship would have an increased draught of about 15 or 16 inches, and her trim would be practically unaltered. If the aftermost compartments were filled, so as to give the ship an increase of 7 or 8 inches in the mean draught, the trim would be changed from $4\frac{1}{2}$ to 5 feet, and the tops of the bulkheads bounding these extreme compartments

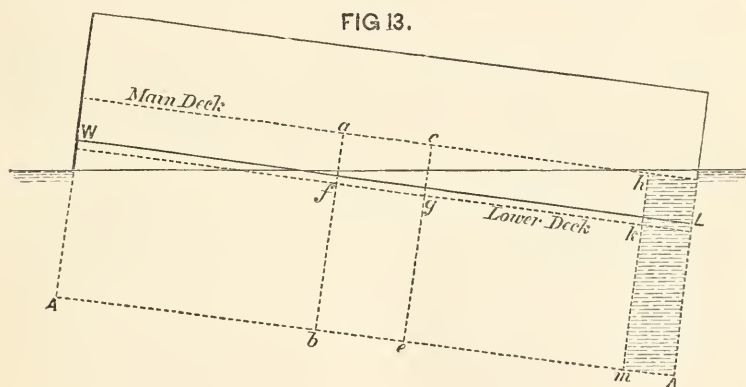

would be put under water. No evil would result, however, for these bulkheads are ended at a watertight iron deck.

Passing from transverse to longitudinal bulkheads, the same principles apply. The heights to which the bulkheads are carried should be carefully proportioned to the sizes of the compartments of which the bulkheads form boundaries; and watertight decks are no less useful as tops to such compartments when the bulkheads cannot be carried high enough to secure the restoration of the lost buoyancy. In this case, however, the longitudinal partitions, supposing only one side of the ship to be damaged, destroy the symmetry of the true "displacement," and the result is that the vessel heels over towards the damaged side. Transverse inclination takes place without change of trim if the damaged compartment is amidships; but if it be near the bow or stern, both change of trim and transverse inclination

will result from the same accident. It is needless to do more than deal with the latter, as the influence of change of trim has already been described; and in this case the box-shaped vessel will once more furnish a simple illustration of what may happen in ships.

In Fig. 14, suppose the large midship compartment bounded by transverse bulkheads, *ab* and *ce* (in profile view), to be subdivided by longitudinal bulkheads, *pq*, *rs* (in section); in the positions shown, these longitudinal bulkheads fairly represent the coal-bunker bulkheads of an ironclad, being rather less than one-fourth of the breadth of the ship within the side. The "wing compartment" lying outside the bulkhead, marked *rs* in section,

FIG 14.

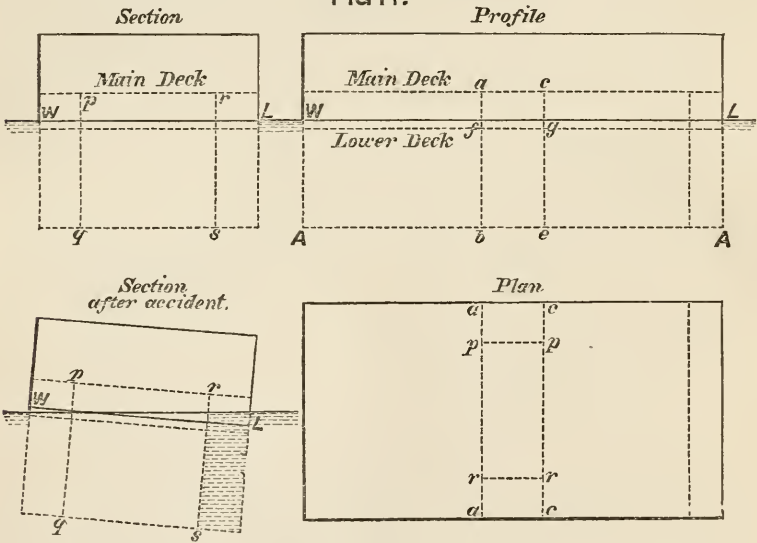

and *rr* in plan, Fig. 14, may be supposed to contain three-sixteenths of the total volume of the compartment between the transverse bulkheads *ab* and *ce*; reckoning up to the load-line *WL*, this will give,

$$\left. \begin{array}{l} \text{Loss of buoyancy when wing} \\ \text{compartment is filled} \\ \text{with water} \end{array} \right\} = \frac{3}{16} \times \frac{1}{4} \text{ total displacement} \\ = \frac{3}{112} \text{ total displacement.} \\ \text{Increase in mean draught} = \frac{3}{109} \text{ original draught.}$$

But this will be accompanied by a heel towards the damaged side, as indicated in the lower section (Fig. 14), amounting, in

the example chosen, to the immersion of the damaged side to about four times the extent of the increased mean draught due to loss of buoyancy. Hence it is clear that, in arranging longitudinal bulkheads, care must be taken either to carry them high enough to provide against heeling or else to have watertight plating forming a top to the compartments.

Lastly, attention must be directed to the usefulness of horizontal watertight decks or platforms in preventing loss of

FIG. 15.

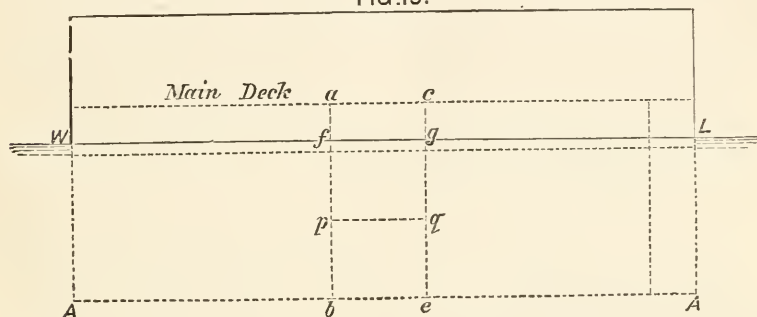

buoyancy. It is unnecessary to repeat what has been said respecting decks lying above the normal load-draught line and forming tops to spaces inclosed by longitudinal or transverse bulkheads; consequently attention will be confined to

FIG 16.

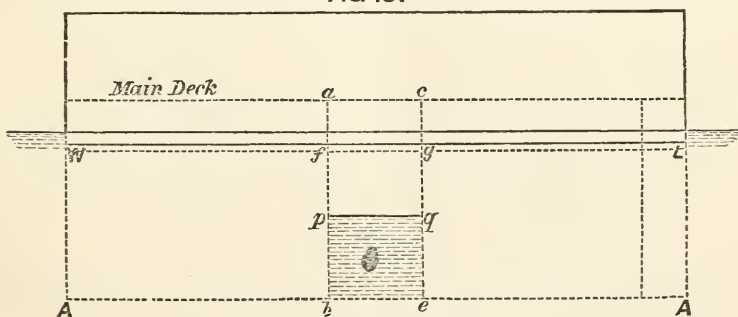

the cases where a deck or platform lies below the load-line. In such cases either one of two accidents may be assumed to have happened: viz. the side has been broken through *below* the platform, or else *above* it. Turning to Fig. 15, let it be supposed that the large midship compartment bounded by the transverse bulkheads *ab* and *ce* has a watertight platform *pq* worked in it, at mid-draught. The volume of this compart-

ment up to the load-line being *one-seventh* of the displacement, the buoyancy contributed by either of the parts into which it is divided by the platform will be one-fourteenth the displacement. If the side is broken through below the platform, the whole of the water-line area WL contributes buoyancy when the vessel is immersed more deeply; therefore, if the whole space is considered accessible to water (as shown in Fig. 16)—

Increase in mean draught due to }
bilging compartment below *pq* } = $1\frac{1}{4}$ original draught.

But if the side is broken through above the platform, only $\frac{6}{7}$ the water-line area contributes buoyancy; therefore (as shown in Fig. 17)—

Increase in mean draught due to }
bilging compartment above *pq* } = $1\frac{1}{2}$ original draught.

FIG 17.

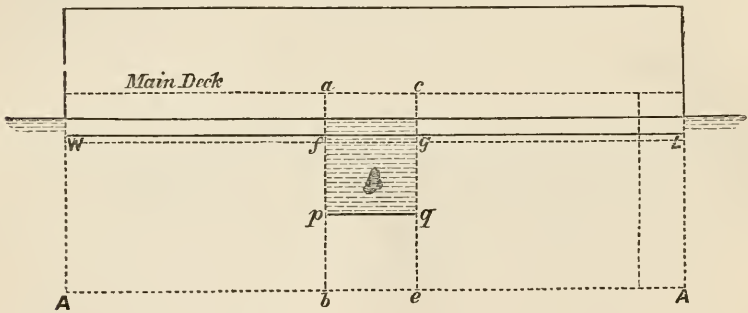

This contrast shows how important a thing it is to take all possible measures to maintain the buoyancy of the ship at the load-line; for any decrease of that buoyancy not merely affects the draught of water, but also decreases the stability of a ship, as will be shown hereafter. It may be added that, in all cases where openings have to be made in a water-tight deck or platform, either watertight covers must be fitted to the openings or watertight trunks, carried to a sufficient height above the load-line, must be built around them.

All the methods of watertight subdivision illustrated above are associated in well-built ships; and the minuteness of subdivision attained when care is taken is well exemplified in Figs. 18-25, which represent the arrangements of the watertight partitions in a modern ironclad of the Royal Navy. Such vessels have the great safeguard of a "double bottom," formed by a watertight inner skin fitted some distance within

the outer skin. This inner skin extends from two-thirds to three-fourths of the total length of the ship; its terminations are marked *c c* in the profile view (Fig. 18) and the "plan of double bottom" (Fig. 20). From the keel up to the turn of the bilge, the inner skin is worked about 3 or 4 feet within the outer; as shown in the sections (Figs. 21-25), from the points *a* downwards. At *a* there is a watertight longitudinal partition (or frame), and the keel is also made watertight. Above the turn of the bilge, the inner skin (*w, w* in the sections) is usually worked vertically up to the height of the main deck, thus inclosing "wing-spaces" in the region of the water-line, or, as it is termed, "between wind and water." The inner skin is here often 8 or 10 feet within the outer. In addition to the longitudinal partitions at the bilges (*a*, in sections) and at the keel, the double bottom is subdivided by numerous watertight transverse partitions (shown by *f f* in Fig. 20), about 20 feet apart; compartments, of very moderate size, being thus formed between the two skins.

Within the limits of the double bottom, the hold-space is subdivided by means of transverse bulkheads (*b b*, Fig. 18), and longitudinal bulkheads (*l l*, Fig. 19). Before and abaft the double bottom there is only a single skin, and the subdivision is effected by means of transverse bulkheads and horizontal platforms (*p p*, Fig. 18). Although there is no inner skin at the extremities, the subdivision there is very minute, and the compartments are small owing to the fineness of form of the bow and stern. The "plan of hold" in Fig. 19, taken in connection with the profile (Fig. 18), will give a very complete view of the subdivision of the hold-space. Besides the main partitions already alluded to, it will be observed that, in many cases, partitions required primarily for purposes of stowage or convenience are made watertight in order to make the subdivision more minute. Examples will be found in the coal-bunker bulkheads, the chain-lockers (immediately before the boiler-rooms), the magazines and shell-rooms, and the shaft-passages. Slight increase of cost and workmanship, with a very small increase in weight, are thus made to contribute to much greater safety. It need only be added that the principal bulkheads either run up to the main deck, situated some 5 or 6 feet above water, or are ended at a watertight platform.

The spaces occupied by the machinery almost necessarily form large compartments amidships; but in recent ships the stoke-holds have each been divided into two by means of a

middle-line bulkhead (*l l*, in Fig. 19); and in vessels propelled

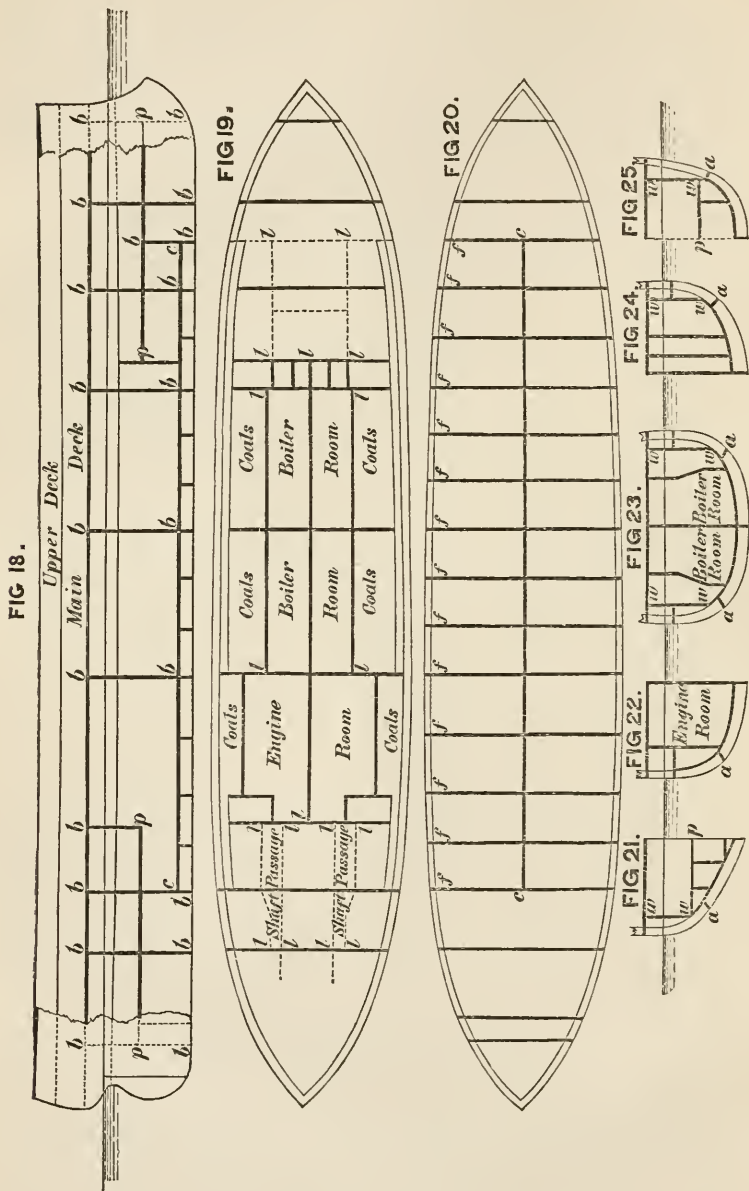

by twin-screws, as is the case in our example, the engine-room compartment is similarly halved. The great advantages result-

ing from this middle-line division are too obvious to need comment, especially in ships which are mainly or wholly dependent upon steam power for propulsion, and exposed to damage under water by shot or shell, ramming and torpedo explosions.

The following table gives the number of compartments in several of the most important ships of the Royal Navy:—

Ironclad Ships of Royal Navy.		Watertight Compartments.		
Classes.	Names.	In Hold-space.	In Double Bottom and Wings.	Total.
Largest early types	<i>Warrior</i> . . .	35	57	92
	<i>Achilles</i> . . .	40	66	106
	<i>Minotaur</i> . . .	40	49	89
Smaller early types	<i>Hector</i> . . .	41	52	93
	<i>Resistance</i> . . .	47	45	92
Largest recent masted types	<i>Monarch</i> . . .	33	40	73
	<i>Hercules</i> . . .	21	40	61
	<i>Sultan</i> . . .	27	40	67
	<i>Alexandra</i> . . .	41	74	115
Smaller masted types	<i>Temeraire</i> . . .	44	40	84
	<i>Invincible</i> . . .	23	40	63
Belted ships	<i>Triumph</i> . . .	26	40	66
	<i>Shannon</i> . . .	44	32	76
Mastless or lightly rigged	<i>Nelson</i> . . .	83	16	99
	<i>Devastation</i> . . .	68	36	104
	<i>Dreadnought</i> . . .	61	40	101
Rams	<i>Inflexible</i> . . .	89	46	135
	<i>Hotspur</i> . . .	26	32	58
Monitors	<i>Rupert</i> . . .	40	40	80
	<i>Gorgon</i> . . .	19	20	39
	<i>Glatton</i> . . .	37	60	97

The *Devastation* may be taken as a good example of a modern war-ship, although she has no middle-line bulkhead in her engine and boiler rooms. Her double bottom and wings are divided into thirty-six compartments; the hold-space into sixty-eight compartments. If the three largest compartments of the hold (viz. the engine and boiler rooms) are filled, the vessel will only be immersed about $3\frac{3}{4}$ feet. If she had a middle-line bulkhead, like the later ships, each of these large compartments would be halved, and it would be most improbable that both halves of any compartment would be filled simultaneously. The total

number of compartments in the hold would then be seventy-one, and filling any six compartments amidships would immerse the vessel as before. The largest compartment in the double bottom holds only about 50 tons of water, corresponding to an increased immersion of only $1\frac{1}{2}$ inch; and the whole double-bottom space will carry 1000 tons of water ballast, the additional immersion being 28 inches.

Similar watertight subdivision is carried out in the unarmoured war-ships of the Royal Navy having iron or steel hulls; and to some extent it is applied also in composite ships. The *Iris* despatch vessel is an illustration of recent practice: she is built in sixty-one separate compartments. In foreign war-ships of recent design the same principles have been applied, and in some instances carried even further than in English ships. For instance, the large armoured frigate *Admiral Duperré* of the French Navy is said to have nearly two hundred separate compartments; and it would appear that equally minute subdivision has been secured in the large Italian ships *Italia* and *Lepanto*. Nor are unarmoured ships exceptions to the prevalent foreign practice.

The value of watertight subdivision is becoming increasingly recognised in merchant ship construction. This fact has been already mentioned, and in Chapter IX. details will be found of the cellular system of construction now extensively employed in iron and steel merchant ships, by means of which their watertight subdivision of the hold-space is supplemented by the valuable feature known as the "double bottom." In Figs. 18-25, the double-bottom arrangements of war-ships have been illustrated, and those recently adopted in merchant ships are shown in Fig. 104a. Double bottoms are advantageous (1) as a means of safety, (2) as a source of economy, when fitted to carry water-ballast, (3) as an efficient arrangement of the thin materials in the lower part of the structure, enabling them to resist longitudinal strains. The last-mentioned feature is discussed in Chapter IX.; respecting the other two a few remarks may be added.

The lower part of any ship is most liable to injury by touching the ground, the thin bottoms of iron or steel ships being peculiarly liable to serious damage. If there be an inner skin, however, and the damage does not extend to it, fracture of the outer skin may be very extensive, but no water will enter the hold. Very many cases are on record, showing the great usefulness of the inner skin; two only will be mentioned. The first is that

of the *Great Eastern*, which has a complete double bottom. Off the American coast the vessel ran ashore, and tore a hole 80 feet long in her outer skin, but the inner skin remained intact, and no water entered the hold. The second is that of her Majesty's ship *Agincourt*, which ran on the Pearl Rock at Gibraltar; this ship has a partial double bottom, and fortunately grounded at a part where the inner skin existed, so that no serious consequences followed.

Considerations of safety and structural strength, chiefly influence the adoption of double bottoms in war-ships: their use as receptacles for water-ballast is unfrequent, although they are generally arranged for such use when required. In merchant ships, however, the chief inducements to use double bottoms have been found in the commercial advantages of water-ballast. Instead of having to incur delays and considerable expense in shipping and discharging rubble-ballast, the commander of a ship fitted for water-ballast can readily admit or discharge such ballast. In some trades the consequent gains are greater than in others, but it is now generally agreed that the balance of advantage, is in favour of ships built with the improved form of double bottom, illustrated in Fig. 104a. The older forms of water-ballast tanks used before the adoption of the cellular system were objectionable in some respects, raising the cargoes high in the ships, and decreasing the space available for stowage; yet the experience gained with these imperfect arrangements has largely influenced subsequent practice.*

The parts of the inner bottom situated above the bilges (see sections in Figs. 21-25) are often termed "wing-passage bulkheads," and are so far inside the outer skin that the chances of their being broken through are much lessened. Similar bulkheads are not fitted in merchant ships; but in many cases longitudinal coal-bunkers are placed abreast the engines and boilers, and a considerable increase of safety is obtained by making the bunker-bulkheads watertight. In a war-ship it is at this part that the greatest damage is likely to be done by ramming or torpedo explosions; and the best known remedy against either is undoubtedly internal subdivision. To attempt to keep out either a ram or a torpedo attack is hopeless; the outer skin is certain to be broken through, and possibly the inner also. But whereas a grazing blow at low speed would suffice to tear a large hole in the outer skin, only the direct blow of a ram moving at

* See a valuable paper "On Water-Ballast," by Mr. Martell (chief surveyor to Lloyd's Register) in *Transactions of Institution of Naval Architects* for 1877.

good speed would be likely to penetrate the inner skin of an armoured ship.

An illustration of the usefulness of the wing-passage bulk-head against ramming or collision was afforded in the accidental collision of the *Minotaur* and *Bellerophon*; the outer skin of the *Bellerophon* was broken, and the armour driven in, but the ship remained on service for some time before the repairs were

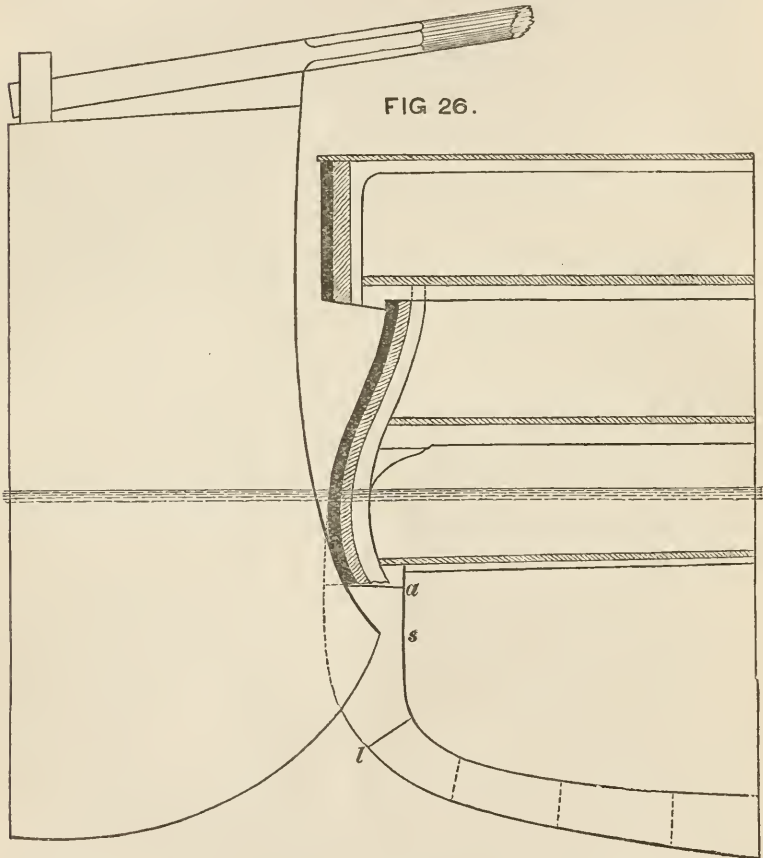

completed. Again, when the *Hercules* and *Northumberland* came into collision, a very similar advantage resulted from the existence of the wing-passage in the latter ship. In the case of the *Vanguard*, although the vessel was lost, the existence of the inner skin was an immense advantage to the ship, keeping her afloat for seventy minutes after the collision, whereas, had there been no inner skin, the vessel must have sunk in a very few minutes. So much misapprehension has existed on this matter

that it may be well to adduce a few facts in support of the foregoing statement. Fig. 26 shows a cross-section of the *Vanguard*, with the bow of the *Iron Duke* in the position which it probably occupied at the time of the collision. It will be noted that, although the armour was driven in, and the armour shelf (*a*) damaged, the inner skin (*s*) was not pierced. This the divers asserted after careful examination, and there is conclusive corroborative evidence that their report is correct. Evidence given before the court-martial proves that at first the vessel sank at the rate of only 8 inches in fifteen minutes, and at last at the rate of one inch per minute; this maximum rate of sinking corresponds to a total inflow of only 27 tons of water per minute, which would have been admitted by an aperture less than *one square foot in area*. But the divers, after measurement, reported that the hole in the outer skin was 10 feet in depth, varying in breadth from 2 feet to 3 feet. Assuming the area to have been 20 square feet (which is probably less than the truth), the initial rate of inflow of water per minute, had there been no inner skin, would probably have been at least 1000 tons, or nearly fortyfold what it actually was at the last. It seems certain, therefore, that the damage to the armour shelf, and other parts of the ship, admitted into the hold in the aggregate no more water than a hole one square foot in area in the skin of an ordinary ship with no double bottom would have admitted, notwithstanding the fact that the *Iron Duke* struck the *Vanguard* a blow much exceeding in force that delivered by the projectile of a 35-ton gun at the muzzle. It is noteworthy also (see Fig. 26, and the sections in Figs. 21–25) that in the *Vanguard* the inner skin terminated about 4 feet under water, whereas in most of her Majesty's ships it is carried to the main deck, several feet above water—a preferable arrangement. Even her loss supplies, therefore, a most striking example of the utility of watertight subdivision, for she was kept afloat more than an hour by this means, instead of foundering in a very few minutes, as an ordinary iron ship similarly damaged in the outer skin must have done. It would be out of place here to further discuss the circumstances attending the disaster, but it may be observed that they illustrate the necessity for taking all possible care in maintaining the integrity of bulkheads and other partitions intended to be watertight, as well as for keeping in thorough working order the doors or covers fitted to any apertures cut in bulkheads or platforms for ventilation or for convenient access to compartments in the hold.

The more recent case of the *Grosser Kurfürst* has been treated,

by some writers, as a proof of the small value attaching to watertight subdivision. This vessel sank in less than ten minutes after her collision with the *König Wilhelm*, notwithstanding the fact that she was extensively subdivided. The circumstances of her loss are well known. She was proceeding in company with her consorts, with watertight doors open in bulkheads and no precautions taken to provide for rapidly closing the doors, such as would have been taken in action. In the endeavour to cross the bows of the *König Wilhelm*, when a collision seemed imminent, the *Grosser Kurfürst* was driven at nearly full speed; and this rapid motion aggravated greatly the injury consequent upon the entry of the spur of the *König Wilhelm* into her side, the skin-plating being torn away for a considerable distance. The access of water to the hold-space was thus made easy, and the ship sank rapidly. Possibly the damage done might have caused her to founder had all possible precautions been taken—doors closed and all watertight partitions secured. But it is clearly unfair to omit consideration of the exceptional circumstances above mentioned, or to depreciate the value of watertight subdivision because the *Vanguard* and *Grosser Kurfürst* were sunk. On the other side numerous cases can be mentioned in which ships, which would otherwise have foundered, have been kept afloat by their watertight bulkheads.

It cannot be claimed for the most minutely subdivided warship that she is absolutely unsinkable. Comparatively large spaces have to be provided for engines, boilers, and equipment; and this puts a practical limit on the minuteness of watertight subdivision. Moreover, the damage inflicted by ramming or torpedo attacks may be so extensive as to throw several compartments open to the sea simultaneously. On the other hand, the chances of escape are obviously increased, as the subdivision is made more thorough. If the primary consideration in the design of a ship were to make her as nearly as possible unsinkable, it would clearly be desirable to associate extensive subdivision into watertight compartments with the use of cork, or other packing materials of small specific gravity. By this means, if there were no limitations of size or cost, it might be possible to produce a vessel which could sustain a very considerable amount of damage before it ceased to be buoyant. The internal spaces to which water could find access would, in the aggregate, bear a small proportion to the reserve of buoyancy; and when damaged the condition of the vessel would resemble that of a water-logged timber-laden ship. The drawbacks to this system are great; size, cost, and propulsive power would all require great increase, and it is

scarcely probable that the plan will ever find favour, except on a limited scale. The system is applied, to some extent, in life-boats; it is also adopted in special classes of armoured ships, wherein the whole or a portion of the length is protected by an under-water deck. For example, in the *Inflexible* and other "central-citadel" ships of the Royal Navy, cork-packing and extensive watertight subdivision are adopted before and abaft the citadel and above the armour deck. Similar methods have been used in certain special vessels designed for torpedo service in foreign navies. In the Italian ships *Italia* and *Lepanto*, which are protected below water by strong decks, extremely minute watertight subdivision of the water-line region above those decks is trusted to preserve the buoyancy and stability. In the *Polyphemus*, of the Royal Navy, a different system is applied; the hold-space is very minutely subdivided, and any loss of buoyancy which may occur in action will be met, either wholly or partially, by letting go iron ballast carried for that purpose. The reserve of buoyancy in this vessel is small, if measured in the manner described on page 10; but the detachable ballast represents a further reserve of about ten per cent. of the displacement.

In the preceding pages considerable use has been made of the "reserve of buoyancy" as a measure of the comparative safety of ships; and this measure very generally commends itself to naval architects as a substitute for linear measurement in statements of the "freeboard" of ships. Freeboard, in its common use, means the height of the upper deck amidships (at the side) above water, and is stated in feet and inches; but this must necessarily be associated in some way with the size of the ship. The old rule for freeboard, commonly known as "Lloyd's rule," was based upon the "depth in hold" of ships, and may therefore be taken as having roughly proportioned the relative volumes of the in-water and out-of-water parts of a ship when floating in still water. The rule was:—

Freeboard = from 2 to 3 inches per foot depth in hold.

In 1867 the council of the Institution of Naval Architects took up this question, proposing to make the freeboard of ships mainly dependent on the beam. Their rule was as follows:—

Freeboard (in feet) = one-eighth the beam, with the addition
of one-thirty-second part of the beam,
for every beam in the length of the ship,
above five beams.

For example, a ship 160 feet long, and 32 feet beam, is *five beams* in length; freeboard = $\frac{1}{8} \times 32 = 4$ feet. If she were 192 feet in length, or *six beams* (one beam in excess of the five): freeboard = $\frac{1}{8} \times 32 + \frac{1}{32} \times 32 = 5$ feet. If she were 224 feet long, or seven beams: freeboard = $\frac{1}{8} \times 32 + \frac{5}{32} \times 32 = 6$ feet. And so on.

This rule obviously fails by the omission of any reference to the *depth* of the ship; deep, narrow ships, which would require exceptional freeboard in consequence of their bad proportions, would by this rule gain upon better-proportioned vessels, and have a relatively low freeboard granted to them. Moreover, in the very long vessels now commonly employed, say with a length *ten* times the beam, the allowance for the additional *five beams* would be proportionately very great—in fact, the freeboard required by the rule might be excessive. On the whole, therefore, in spite of the authority on which the proposed rule rests, it is not surprising that it has never come into general use.

In connection with the recent legislation for the safety of merchant shipping, and the inquiry of the Royal Commission of 1874, upon which that legislation has been based, the question of freeboard, with its closely allied topic—load-draught—has been much discussed. After taking the evidence of many professional men, the commission came to the conclusion that no general rule for freeboard and draught could, with advantage, be laid down. Consequently the law now fixes no minimum of freeboard, but requires the shipowner to mark upon the sides of the ship the maximum draught which he proposes not to exceed in loading her for any voyage. The decision as to ships being overladen or not now rests with surveyors appointed by the Board of Trade. These surveyors have the power of detaining ships considered to be overladen; and their decision is subject to revision by local courts of survey.

The Committee of Lloyd's Register of Shipping have for some years been in the habit of fixing the maximum load-line of "awning-decked" ships (see page 55) classed with them; and this special practice is said to have given satisfactory results. On the other hand, it is asserted by some authorities that the existing law which leaves to the owner the responsibility of fixing the load-line in each ship has tended to produce dangerously deep loading in many instances. In order to remedy these evils, and to supply the professional knowledge required in fixing a reasonably safe load-line, it has been proposed to constitute a central authority of a representative character, to which these

difficult questions might be referred. In this authority it is suggested that there should be included shipowners, shipbuilders, seamen, underwriters—in short, members of all classes interested in shipping; and that they should have the assistance of competent naval architects to make the calculations and investigations necessary for forming opinions on each case submitted. No action has been taken in the matter up to the present time (1882), but the general features of the scheme have been very favourably received, and it may be adopted eventually. Many persons who were formerly opposed to official interference with the shipowner, have expressed their concurrence in this mode of dealing with the load-line question for merchant ships.* The difficulties surrounding the question would not be removed by this action, but they might be better dealt with than under the present system. The conditions of buoyancy and stability belonging to the assigned load-line of each type of ship would require careful investigation, in order that on the one side there may be a reasonable amount of safety with the worst conditions of lading likely to occur, and on the other that the owner might be permitted to load deeply enough to provide for variations in the character of the cargo carried on different voyages.

In ships of war the freeboard is usually governed by considerations of the height at which guns should be carried to be fought efficiently, rather than by considerations of safety from foundering. These considerations of fighting efficiency generally involve the adoption of a height of freeboard much in excess of what would be considered necessary in merchant ships. Even in the breastwork monitors, with their upper decks some 3 or 3½ feet above water, the reserve of buoyancy, augmented as it is by the breastwork which stands upon the upper deck, is about equal to that which good authorities fix for the average reserve in merchant vessels fairly laden.

Hereafter it will be shown that the height of freeboard also exercises an important influence in preventing ships from being easily capsized by the action of the winds and waves.

* See the Evidence and Reports of the Royal Commission on Tonnage (1881).

CHAPTER II.

THE TONNAGE OF SHIPS.

AT a very early period the necessity must have been felt for some mode of measuring the sizes of ships, either for purposes of comparison, or for estimating the cost of construction, or for determining the carrying capacity, or for computing the various dues and duties from time immemorial levied upon shipping. In some ancient documents statements occur of the "tonnage," or "portage," of ships; but it is not possible to settle how this tonnage was calculated. Legal enactments respecting the tonnage measurements of merchant ships are of comparatively modern date, when contrasted with the period during which some system of tonnage measurement is known to have been in common use. Even the origin of the term "tonnage" is not certainly known, although it is probable that it was based upon some rough approximation to the number of butts, or *tuns*, of wine which a vessel could carry. This kind of tonnage, therefore, must have depended upon the *internal capacity* of ships; and hence there would arise the desire to arrange some method of calculation giving a fair approximation to the carrying power of a ship, in terms of her principal dimensions—length, breadth, and depth; or in terms of the length and breadth only, if the depth maintained nearly a constant ratio to the breadth. When such an empirical formula had been devised and well tested, it would work satisfactorily so long as the types of ships, their forms, proportions, and methods of construction remained unchanged. Changes in any or all such features would, however, make the empirical formula unsuitable; and, resting upon no scientific basis, it might be evaded by means of various devices if it became the basis for the assessment of dues or taxes. So long as the conditions remained unchanged these empirical rules

answered another useful purpose, giving the means of approximately estimating the *maximum dead weight* of the cargo which a ship could carry. This "dead-weight capability" may be assumed to have been one of the fairest measures of the earnings of merchant ships in the earlier periods of navigation, when passenger traffic was of very small importance. And for ships of similar type, proportions and construction, the ratio of internal capacity to dead-weight capability was fairly constant.

The earliest English tonnage law that can be traced was passed in 1422: it applied exclusively to one class of vessels, the "keels" used in carrying coals at Newcastle, and is believed, although this is not certain, to have reckoned tonnage by the number of tons (dead weight) carried. In 1648 and 1694 the same class was made the subject of special tonnage laws; and in the latter year it was provided that, in measuring keels, actual weights of known amount should be put on board, the corresponding draughts of water being noted and permanently marked on the stem and stern. In 1775 this system was extended to all vessels loading coals at all ports of Great Britain.*

Another tonnage law, limited in its action to ships engaged in carrying spirits, was passed in 1720, for the purpose of preventing smuggling in small vessels of "thirty tons burthen and under." This law prescribed internal measurements of length of keel, and inside midship breadth: the continued product of that length, breadth, and half-breadth being divided by ninety-four, in order to determine the tonnage. Although these internal measurements appear to make the rule express some fraction of the internal capacity, yet, for the reasons given above, it also, probably, gave an approximate expression for the maximum dead weight, or "burthen," in tons. Mr. Moorsom was of this opinion, after a careful analysis of ships similar to those employed in the spirit trade.

In passing it may be interesting to state that in France the earliest tonnage laws were intended to express approximately the *internal capacity* of ships, or some fraction thereof. By the *Ordonnance de la Marine* of 1681, issued by Colbert, 1 ton of tonnage equalled 42 cubic feet of internal space, or about 1.44 cubic metres. This was the space supposed to be required for the stowage of four *barriques*, or wine-casks. In finding the internal

* For an excellent historical review of the earlier English legislation, see

the late Mr. Moorsom's book on *The Laws of Tonnage*. London: 1852.

volume three cross-sections were taken in the ships, the areas of these sections were estimated roughly, and a mean area found, which, multiplied by the length, and divided by forty-two, gave the tonnage. The process was rough, but it appears that here also, the final result gave a tonnage fairly approximating to the dead-weight capability of the ships to which the rule applied when it was framed. Bouguer, with his usual discrimination, pointed out the weak points of this system; and proposed improved methods, anticipating by his suggestions (made in 1746) most of the proposals for tonnage measurements since made. If internal capacity was to be the basis of tonnage, he proposed to make the measurements in a strictly scientific manner, much as is done under the Moorsom system now in use (see page 46); and, if dead-weight capability was to be used, he proposed to determine it by estimating the displacement between the light and load-lines (see page 61). For port dues he proposed to take the volume of the parallelepipedon circumscribing the ship, since that practically measured the space she occupied.*

Reverting to English tonnage legislation, reference must next be made to the law of 1773, which was the first legal tonnage measurement applied to all classes of merchant ships. This mode of estimation, known as "Builder's Old Measurement" (B.O.M.), was based upon the long established practice of British shipbuilders, but previously had no legal force, and was not applied in an exactly uniform manner by different builders. With these minor variations in practice, the use of B.O.M. tonnage can be traced back for centuries, and doubtless answered its purpose well during the long period preceding the present century, when naval architecture made little progress, types of ships and methods of construction being almost stereotyped. It was probably intended to express the *dead-weight capability* of ships, that being the basis of tonnage universally regarded as the fairest when the law was passed. Up to that time, also, there is reason to believe that the intention was fairly well fulfilled; but subsequently it was the object of shipbuilders and shipowners to increase, as much as possible, the ratio of the dead-weight capability to the legal tonnage, and the empirical character of the rule made this an easy matter. The rule may be briefly stated as follows:—

(a) The *length* was taken on a straight line along the rabbet

* For details see the *Traité du Navire*.

of the keel of the ship from the back of the main sternpost to a perpendicular line from the fore part of the main stem, under the bowsprit. Fig. 27 shows this; CA is the perpendicular line, and AB is the length required. If the ship was afloat when the measurements for tonnage were made, the length AB could not be taken; and to allow for the rake of the sternpost (BE), and the consequent shortening of the keel, as compared with the length along the deck or water-line, a deduction was permitted of 3 inches for every foot of draught of water from the length measured along the water-line from the perpendicular line AC to

FIG 27.

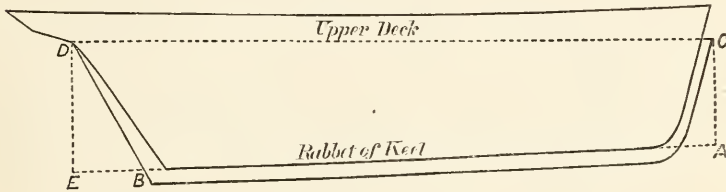

the back of the sternpost. Long after raking sternposts ceased to be used in war-ships, a deduction continued to be made for the "rake" of a post which was upright, in order to secure a small diminution of the tonnage. By an additional act passed in 1819 the length of the engine-room was also deducted in ascertaining the length for tonnage of merchant steamers; but no similar deduction was made in steamships of war.

(b) The *breadth* was taken from the outside of the outside plank in the broadest part of the ship, exclusive of any additional thickness of planking or doubling strakes that might be wrought at that part. This reduction from the extreme breadth to obtain the "breadth for tonnage" amounted to 10 or 11 inches in large vessels, decreasing to 3 or 4 inches in small vessels; it expressed the excess in thickness of the "wales," worked in the neighbourhood of the water-line, over the ordinary bottom planking. In iron ships the breadth extreme and breadth for tonnage are usually identical, except in cases where the armour shelf "overhangs" the hull proper. The *Devastation* is a case in point. Her breadth extreme (to outside of armour) is $62\frac{1}{2}$ feet; the armour and backing (on both sides) project some $4\frac{1}{4}$ feet beyond the hull beneath, and the breadth for tonnage was consequently only 58 feet. In the American monitors, with overhanging armour, similar deductions were made from the extreme breadth in estimating the breadth for tonnage. For example, the *Dictator*

had a breadth extreme of 50 feet, and a breadth for tonnage of 41 feet 8 inches.

(c) From the length obtained as described in (a) was deducted three-fifths of the breadth for tonnage, the remainder being termed the "length for tonnage." This was multiplied by the breadth, and their product by half the breadth, and dividing by 94, the quotient expressed the tonnage.

In algebraical language, if L = the measured length along the rabbet of keel; B = breadth for tonnage,

$$\begin{aligned} \text{Length for tonnage} &= (L - \frac{3}{5} B); \\ \text{Tonnage B.O.M.} &= \frac{(L - \frac{3}{5} B) \times B \times \frac{B}{2}}{94}. \end{aligned}$$

As an example take a ship for which $L = 200$ feet, $B = 50$ feet;

$$\begin{aligned} \text{Tonnage B.O.M.} &= \frac{(200 - \frac{3}{5} \times 50) \times 50 \times \frac{50}{2}}{94} \\ &= \frac{170 \times 50 \times 25}{94} = 2260\frac{60}{94} \text{ tons.} \end{aligned}$$

The continued product in the numerator expresses capacity; and it is probable, as remarked above, that the divisor 94 was chosen with reference to the carrying power of the ships in tons of dead weight. The following explanation has been suggested as to the choice of the divisor. In the older classes of sailing ships the length was commonly about four times the breadth; consequently the "length for tonnage" was about 3.4 times the breadth. The mean draught was about one-half the breadth; and the coefficient of fineness for displacement (see page 4) was about *one-half*. Hence it followed that the displacement in cubic feet, was not very different from the product

$$\cdot 5 \times \text{Length} \times \text{Breadth} \times \cdot 5 \text{ Breadth};$$

Introducing the value for the length for tonnage stated above, this expression was supposed to resolve itself finally into the approximate equation:

$$\begin{aligned} \text{Displacement (in cubic feet)} &= \frac{620}{1000} \times \text{Length for tonnage} \\ &\quad \times \text{Breadth} \times \frac{\text{Breadth}}{2} \end{aligned}$$

$$\begin{aligned} \therefore \text{Displacement in tons} &= \frac{620}{3300} \times \text{Length for tonnage} \\ &\quad \times \text{Breadth} \times \frac{\text{Breadth}}{2}. \end{aligned}$$

The hulls of these vessels are said to have weighed about 40 per

cent. of the displacement, 60 per cent. representing the carrying power. Hence,

$$\begin{aligned} \left. \begin{array}{l} \text{Approximate carrying power} \\ \text{(in tons, dead weight)} \end{array} \right\} &= \frac{3}{5} \times \frac{62}{3500} \times \text{Length for tonnage} \\ &\quad \times \text{Breadth} \times \frac{\text{Breadth}}{2} \\ &= \frac{1}{94} \times \text{Length for tonnage} \\ &\quad \times \text{Breadth} \times \frac{\text{Breadth}}{2}, \end{aligned}$$

which agrees with the B.O.M. rule. This investigation will be seen to proceed upon certain fixed proportions of breadth to length and draught, as well as of weight of hull to displacement. Departures from these proportions rendered the rule useless as a measure of carrying power; and it was evaded when its legal enactment supplied a motive for so doing. In order to produce vessels of small nominal tonnage but great carrying power, raking stemposts and other small devices were employed; but the adoption of great depth, in association with very full forms under water, was most influential. These deep heavy-laden "box-shaped" vessels were, of course, far inferior to vessels of good proportions as regards speed, safety and good behaviour at sea. The numerous disasters which resulted, and the obvious inferiority of British to foreign merchant ships, being distinctly traceable to the bad influence of the tonnage law, led to an agitation for its repeal. An Admiralty Commission investigated the subject in 1821, and reported in favour of dead-weight capability, to be ascertained by means of an approximate rule, based on a few internal measurements. This rule also would have been easily evaded, and was not adopted. A second Commission was appointed in 1833, and reported in favour of "internal capacity as the fairest standard of measurement, including all those parts of a vessel which, being under cover of permanent decks, are available for stowage." Great opposition was raised to any change in the law; but finally, in 1836, another tonnage law was enacted known as the New Measurement, in general accordance with the recommendations of the Commission. To this New Measurement attention will be drawn hereafter; but it is first necessary to trace the continued use of the B.O.M. rule, after it ceased to have any legal force, and it will be convenient in this connection to describe the tonnage measurements of war-ships.

Many private shipbuilders and shipowners, having been long accustomed to the use of the earlier rule, and having their *data*

recorded in that form, preferred to resort to it in their business transactions, although it was not the legal measure; and even at the present time the use of the B.O.M. rule has not entirely disappeared in the mercantile marine. For yachts a modification of the same rule is still extensively employed in assessing time allowances, as is explained on page 67. In yachts and war-ships there was not so great a temptation to sacrifice good qualities, in order to make the nominal tonnage small as existed in merchant ships; and the B.O.M. rule continued to be employed in the Royal Navy and in some foreign navies until comparatively recent periods. Until 1872 the B.O.M. tonnage was the only one given in the Navy List for Her Majesty's ships; and still more recently a slight modification of that rule was employed in the United States Navy. Even now the B.O.M. tonnage is given for ships of the Royal Navy built before 1872; but is supplemented in these cases by the displacement tonnage, and does not appear for ships of more recent date. The study of our naval history leads to the conclusion that every marked change or improvement made during the present century, while the old tonnage rule was employed for war-ships, has been accompanied by a protest against, or disregard of its limitations. By general consent displacement tonnage is now taken as the fairest measure for war-ships, and a few examples drawn from the Navy List will serve to show more clearly the inconsistencies and errors involved in applying the old measurement to modern ships.

Ships.	Displacement.	B.O.M.
{ <i>Warrior</i>	9,137	6,109
{ <i>Devastation</i>	9,387	4,407
{ <i>Minotaur</i>	10,627	6,621
{ <i>Dreadnought</i>	10,886	5,030
{ <i>Howe</i>	6,557	4,245
{ <i>Bellerophon</i>	7,551	4,270
{ <i>Glatton</i>	4,912	2,709
{ <i>Boadicea</i>	4,027	2,679

Taking these vessels in pairs, the first two illustrations show how widely different may be the tonnages B.O.M., when the displacements are very close to one another; while the last two illustrations show how, with nearly identical tonnages B.O.M., the displacements may differ considerably.

Displacement tonnage, as explained on page 2, expresses the total weight of a ship (in tons) when immersed to her maximum draught or "load-line." For war-ships this measurement is especially suited, since they are designed to carry certain maximum weights, and to float at certain load-lines, which are fixed with reference to the character of the service. It has long been the official tonnage for the war-ships of France and other European countries, and now that it has been adopted for the Royal Navy and the United States Navy may be said to be universally employed. It will be obvious that a simple comparison of displacements affords no means of judging the relative powers of two war-ships. A displacement of given amount may be very differently distributed in different ships. For example, one may be an armoured coast-defence vessel of low speed, small free-board, heavily protected and armed, but carrying small weights of coal or equipment. Another may be a sea-going armoured frigate with high sides, good sail-power, large coal-supply and equipment, higher speed, with lighter armour and armament. A third may be an unarmoured cruiser of very high speed, intended to keep the sea for long periods and to sail as well as steam, with large coal-supply, good equipment and light armament. In each of these cases and others which might be mentioned the distribution of the constant displacement into the various percentages assigned to hull, machinery, coals, armament, armour and equipment will necessarily vary greatly. Consequently it is desirable when using displacement tonnage as a means of comparison for war-ships, and in order to estimate the skill displayed by the designers, to restrict the comparison to ships of similar types, built for similar service.

Displacement tonnage, it may be added, has no relation to the dues occasionally levied on war-ships, as for example in passing through the Suez Canal. For those purposes the register tonnage or its modification for the canal dues is employed, the necessary measurements for British ships being made by officials of the Board of Trade (see page 59). Reference will be made hereafter to the proposals to use displacement tonnage for merchant ships, instead of the present system.

Another kind of tonnage measurement, appearing in statistical statements of ships building for the Royal Navy, may be mentioned here. When a new ship is designed, an estimate is made of the total weight of hull, armour (if any) and fittings, as well as an estimate of the cost of the labour that will be expended on her construction. This cost, when divided by the total weight of

hull, &c., gives the average expenditure on labour in building one ton weight, and for statistical purposes that average expenditure per ton is reckoned as "a ton" in the shipbuilding programmes of the navy estimates. For example, if an armoured ship has a total weight of hull, &c., of 6,000 tons, and the total expenditure on labour in her construction is estimated at £150,000, the average expenditure per ton weight of hull will be £25. Then, as the work proceeds, it is assumed that for each £25 spent on labour, a "ton" is added to the ship. It will be seen, therefore, that this kind of ton is really only an equivalent for money spent on labour; the expenditure on materials being stated separately. Moreover, at different stages of the work the weight of material actually worked into a ship for each unit-ton of expenditure must vary greatly, and the money-value of the unit-ton will differ considerably in one class of ship from its value in another class. The form of expression is, consequently, open to misconception, and various proposals have been made to abolish the term "tonnage" in statements of the kind now being considered, giving expenditure on labour simply. Such a change would be advantageous in many ways, although it would be a departure from long-established usage. Prior to 1874-5, the amount of tonnage annually added to the Royal Navy was expressed in "Builder's Old Measurement," which was even less satisfactory than the present form. It may be added that, on an average, a "ton" in the shipbuilding programmes since 1874-5, is about equal to 91 per cent. of a ton for armoured ships in preceding programmes, and to 144 per cent. of a ton of unarmoured ships.

Resuming our consideration of British tonnage laws, it now becomes necessary to refer again to the new measurement which was in force from 1836 to 1854. This law aimed at the determination of the internal capacity of ships, resembling in this respect the French law of 1681. The rules laid down for the purpose need not be reproduced here; but it may be stated that they involved the measurement of certain lengths, breadths, and depths in a few specified positions, and were, consequently, open to evasion. By means of various devices, shipbuilders were able to secure a considerable excess in the true capacity over the nominal capacity, amounting to as much as 15 per cent. in some cases. Mr. Moorsom summed up his review of the operation of this law as follows:—"Although it has suppressed the premium hitherto given to the building of short, deep ships, and although great improvements in our commercial navy have accrued under

it, yet as it offers so many facilities for evasion, and is not, from the very nature of its constitution, to be depended on generally in its results, it cannot be expected to possess either the confidence or approbation of the public." A third Commission on tonnage was appointed in 1849, and it recommended that the "entire cubic contents of all vessels externally" should be carefully measured, and made the basis of dock, light, harbour, and other dues. PooPs, forecastles, and other covered-in spaces were also to be measured and included in the tonnage. The total volume in cubic feet was to be divided by 35, and 27 per cent. of the quotient was to be the register tonnage of sailing vessels. In steamers the tonnage due to the engine-room was to be deducted; this was to be done because corresponding deductions had been made in preceding laws, but the Commission expressed a doubt as to the propriety of making any such deduction. This proposal was not adopted, and it is mentioned here chiefly because it has been many times repeated since it was first made.

The principal objection urged to this system of external measurement was, that the fairest measure of the earnings of a ship was to be found in her *internal capacity*, as affirmed by the Commission of 1833. As this is a matter of considerable importance in connection with the enactment of the tonnage law of 1854, which is still in force, it may be desirable to quote Mr. Moorsom's statement: "It is alleged," he writes, "that light merchandise (meaning thereby such merchandise as fills the hull of the vessel without wholly loading her to the load-draught of water) forms the predominant cargoes of commerce, and constitutes for the most part the profits of the ship; and, therefore, it is maintained that the internal capacity, on which the stowage of this merchandise entirely depends, must be the fair and proper basis for assessment. Besides, the poops, spar-decks, &c., which are appropriated entirely to passenger traffic, frequently form a large item in the profits of the ship." Again he says: "Having assumed, as affirmed to be the case by the generality of ship-owners . . . that the profits of a vessel are, for the most part, directly dependent on the quantity of space for the stowage of cargo and accommodation of passengers—having assumed this as an incontrovertible condition of the question—all further investigation of the subject has gone to prove the superior eligibility and desirableness of internal measurement." These views were embodied in the system of tonnage measurement which was included in the Merchant Shipping Act of 1854, and which is generally termed the "Moorsom system," because that gentleman

had most to do with its introduction. The *register tonnage* of all British merchant ships has since been measured on this system, and the regulations of 1854 are still in force (1882) with two modifications, introduced respectively by Acts passed in 1867 and 1876. If the principle of measurement of internal capacity, as the most equitable basis for tonnage, be accepted, the rules devised by Mr. Moorsom are admirably adapted for correctly estimating the tonnage. They rest upon scientific principles of mensuration, are simple in their character, and involve only a moderate amount of labour. Their excellence is illustrated by the fact that, although they have been in operation nearly thirty years, during which shipbuilding has sustained remarkable developments, and the structure, sizes, lengths, and methods of propulsion of ships have been greatly changed from the corresponding features in the ships of the period when the rules were framed, only small modifications in some points of detail are needed to make them equally applicable to all classes of ships of the present day. Without any modification the rules give results fairly approaching to accuracy; but if the principle of the existing law is maintained, certain simple modifications in the rules would enable a still further approach to accuracy to be made.

A description of the existing rules for calculating tonnage cannot be given here. For the hold-spaces below the tonnage-deck, the process closely resembles that pursued by the naval architect in calculating the volume of displacement for a ship. Actual half-breadth measurements are taken by the surveyors of the Board of Trade, in the interior of the ship, if that is accessible. The longitudinal and the vertical intervals between these measurements are varied with the length and depth of the ship, the intention being to space them sufficiently close to indicate fairly the true shape of the interior, and to prevent evasions of the law by any local thickening of the inside lining or other devices. Having obtained these measurements, the first step in the calculation is to find the areas of a series of equidistant vertical transverse sections of the hold-space below the tonnage-deck; and, secondly, to use these areas in estimating the volume of the hold-space. If there is a deck above the tonnage-deck, the volume of the space between the decks is separately estimated. All closed-in spaces above the upper-deck—such as poops, forecastles, deck-houses, &c.—erected for purposes of accommodation or stowage, also have their volumes separately estimated. The sum of all these volumes in cubic feet, divided by 100, expresses what is usually termed the "*gross tonnage*" of a

merchant ship. By the Act of 1876 also, if, on any voyage, a ship carries cargo in any space upon the upper deck which has not been measured into the tonnage under the Act of 1854, the tonnage of the space occupied by the deck-cargo is to be measured and added to the taxable tonnage. This later regulation was understood to be aimed at the discouragement of deck-cargoes on seagoing ships; and it will be seen to have the effect of giving ships a variation in tonnage from one voyage to another, although in all cases the principle is maintained that space occupied by cargo shall be reckoned into the tonnage. Dues are not paid, however, upon the gross tonnage in most cases, but on the "nett" or "register" tonnage obtained from the gross tonnage by making certain deductions, to which attention will be directed hereafter.*

In order to provide for the measurement of the gross tonnage in laden ships, where the holds could not be cleared, the Act of 1854 contained an approximate rule (No. 2) based upon external measurements. This was especially useful in dealing with foreign ships entering British ports, and runs as follows:—The length is taken at the upper deck from the fore point of the rabbet of the stem to the afterpoint of the rabbet of the post. The extreme breadth of the ship is also taken, and a chain is passed under her at this place in order to determine the girth of the ship as high up as the upper deck. Then the approximate gross tonnage under the upper deck is estimated by the formulæ:

$$\begin{aligned} (1) \text{ For wood and } & \left. \begin{array}{l} \text{composite ships.} \end{array} \right\} = \frac{17}{10000} \left(\frac{\text{Girth} + \text{Breadth}}{2} \right)^2 \times \text{Length.} \\ (2) \text{ For iron ships.} & = \frac{18}{10000} \left(\frac{\text{Girth} + \text{Breadth}}{2} \right)^2 \times \text{Length.} \end{aligned}$$

In the Act of 1854, larger co-efficients were given, namely, $\frac{18}{10000}$ for wood ships, and $\frac{21}{10000}$ for iron ships; but enlarged experience led, many years ago, to the substitution of the co-efficients still in use. This approximate rule for the gross under-deck tonnage is gradually falling into disuse, for two reasons—First, all new British ships are measured by the more exact method; and secondly, so many foreign nations, including all the

* For full particulars of the Tonnage Laws now in force, the methods of measurement, processes of calculation, &c., the reader may turn to the

Appendix attached to the Minutes of Evidence taken before the recent Royal Commission on Tonnage. *Parliamentary Paper*, C 3074 (1881).

most important mercantile marines, have now adopted the Moorsom system for gross tonnage, that their legal tonnage, inscribed on the certificates of foreign ships, can be accepted.

Other approximate rules have been given for estimating gross under-deck tonnage. Mr. Moorsom proposed the following rules about twenty-five years ago: If L be the inside length on upper deck from plank at bow to plank at stern, B the inside main breadth from ceiling to ceiling, D the inside midship depth from upper deck to ceiling at limber-strake. Then the gross tonnage under deck may be approximately expressed by the equation:

Tonnage = $L \times B \times D \times$ a decimal factor $\div 100$, wherein the decimal factor has the following values:—

	Decimal factor.	
Sailing ships of usual form	·7	
Steam vessels and clippers {	Two-decked	·65
	Three-decked	·68
Yachts {	Above sixty tons	·5
	Small vessels	·45

These factors cannot be regarded as applying so well to ships of the present day as to those of twenty-five years ago. It may be interesting, therefore, to give another approximate rule for gross under-deck tonnage in the form most useful in making rough estimates of the tonnage in new steamships, for which the principal dimensions are known. Let L be the length, at the load-line, from the front of the stem to the back of the stern-post; B the extreme breadth (moulded) to the outside of the frames; D the depth from the top of the upper-deck amidships to the top of the keel: then, if ordinary methods of construction are followed, the following rules hold fairly well for iron or steel steamships of modern types:—

Gross tonnage under deck = $L \times B \times D \times$ decimal factor $\div 100$.
Wherein the decimal factor has the following values:—

	Decimal Factor.
Passenger steamers of high speed	·65
Passenger and cargo steamers	·7 to ·72
Cargo steamers	·72 to ·75

Special structural arrangements might sensibly modify the value of these factors; and it will be understood that they are useful only in rough estimates, not as substitutes for exact calculations of tonnage.

Passing from gross to "nett tonnage," it should be stated that the nett or "register" tonnage is intended to express, in tons of 100 cubic feet, the volume of the spaces actually available in a ship for remunerative service, such as the conveyance of passengers or the stowage of cargo. Considerable discussion has taken place, at various times, as to the determination of the spaces to be included in this category in different classes of ships; in other words, as to what deductions shall be made from the gross tonnage in estimating the nett register tonnage. Before referring further to these difficulties it may be well, however, to briefly summarise the present practice.

In sailing ships the only deductions allowed are for the spaces solely occupied by the crew, provided they do not fall below 72 cubic feet per man, and are properly ventilated. This arrangement was authorised by the Act of 1867, and no limit is assigned to the crew-spaces; but if cargo is carried in them, the deductions cease to be made. From the facts recorded as to actual accommodation it appears to vary from nearly 10 per cent. in small sailing ships down to $3\frac{1}{2}$ per cent. in vessels approaching 2000 tons gross tonnage; the average may be taken at from $\frac{1}{4}$ to 5 per cent. In other words, the nett register tonnage of sailing ships may be assumed to be about 96 per cent. of their gross tonnage. The Royal Commission of 1881 recommended that a further deduction should be allowed for the space occupied by the sail rooms, the maximum allowance not exceeding $2\frac{1}{2}$ per cent. of the gross tonnage. No legal force has yet been given to this recommendation.

In steamers similar deductions are allowed for crew-space, and the average percentage of gross tonnage assigned appears to be nearly the same as that named for sailing ships. Much more important deductions are allowed on account of the spaces occupied by the machinery and coals, such spaces being regarded as lost to the cargo-carrying capacity of the vessel, and therefore not remunerative. The fundamental principle, that nett register tonnage (upon which the dues are estimated for any ship) shall only include spaces used for cargo-carrying or passenger accommodation is thus supposed to be maintained; but the fairness of making any such allowances to steamers, or, if any, how great allowances, has been the subject of much discussion. The Act of 1854 is still in force, however, although confessedly imperfect, and under it the deductions are made in one of two ways. The space "solely occupied by and necessary for the proper working of the boilers and machinery" is measured (shaft-passages, funnel-

casings, ventilation trunks, &c., being included herein). If this space has a tonnage, in screw-steamers, above 13 per cent. of the gross tonnage and under 20 per cent., the total deduction permitted, for machinery and coal-space, is 32 per cent. of the gross tonnage. In paddle-steamers, if the measured space has a tonnage above 20 per cent. and under 30 per cent. of the gross tonnage, the total deduction permitted is 37 per cent. This is the first, or "percentage," method supposed to be applicable to all ordinary steamers. The second method is applied where the space occupied for the machinery falls below 13 per cent. or above 20 per cent. of the gross tonnage; the space may then be measured (as before), and the total deduction from the gross tonnage is to be 50 per cent. more than the measured space in paddle-steamers, and 75 per cent. in screw-steamers. These additions to the measured space are considered to allow fairly for the coal-stowage required for a voyage of average length.

Very soon after the law of 1854 came into operation the grave defects of the rules for engine-room deductions became apparent, and an attempt was made by the Board of Trade to introduce amended rules. It was, however, decided that these amendments could only be made by Act of Parliament, and hitherto no such Act has been passed, although several have been introduced. Under the existing law it is much to the advantage of the shipowner to arrange the machinery-space in the majority of ocean-going screw-steamers, so as to bring it a little above 13 per cent. of the gross tonnage, and to secure the 32 per cent. deduction. Take, for example, two steamers, each of 3000 tons gross, and suppose that in one the machinery space is $12\frac{2}{3}$ per cent. of the gross tonnage, while in the other it is $13\frac{1}{3}$ per cent. The deductions would be as follows:—

First steamer :	Tons.
Actual machinery space . . .	380
Add 75 per cent. of ditto . . .	285
	—
	Total deduction 665
	—
Second steamer :	Tons.
Actual machinery space . . .	400
Deduction allowed (32 per cent. of } gross tonnage) }	960

That is to say, the shipowner, by increasing the machinery-space 20 tons, secures an increase in the deduction of 295 tons. The

loss in space available for coals and cargo is therefore only 20 tons, whereas he pays dues on a nominal tonnage 295 tons less than would be charged on the ship with the slightly smaller engine-room. This is but one illustration out of many that might be given of the imperfection of the present percentage system: but shipowners are naturally averse to a change which would deprive them of this source of profit. A careful analysis of many cases has shown that the actual space available for stowage in ocean-going steamers coming under the percentage rule exceeds the space corresponding to the nett tonnage by from 10 to 12 per cent. This is an obvious departure from the fundamental principle which was intended to be embodied in the Act of 1854; and the owners of sailing ships as well as the proprietors of docks have not failed to complain of the anomalies resulting therefrom. As a result of the application of the percentage method, and allowing for crew-space, the nett register tonnage of the great majority of sea-going screw-steamers is about 64 per cent. of the gross tonnage.

The second rule for engine-room deductions is also open to serious objection as applied to certain classes of steamships. For steamers making passages of 3000 to 4000 knots between coaling stations, 75 per cent. of the measured machinery-space is said to be a fair average allowance for the space actually occupied by coals. It will be obvious that if this is true now, it could not have been true when the law was framed, marine engineering having been so greatly developed in the direction of economy in coal consumption (see Chapter XIII); and it is also evident that further improvements may sensibly affect the space required for coals or fuel. Passing this difficulty by, however, and accepting the foregoing statement, it will appear that for many steamers employed on coasting or short sea-voyages, the coal-space actually required falls much below 50 or 75 per cent. of the machinery-space. In channel or river passenger steamers of high speed and in tugs the anomaly is greatest: and recent cases have illustrated it most forcibly. By an interpretation of the Act of 1854 which has been upheld in the law courts, cases have occurred in which the nett tonnage of swift passenger steamers has been reduced to little more than 22 per cent. of their gross tonnage, and 30 to 40 per cent. is quite a common value. Tugs of considerable gross tonnage, by the application of the same rules, have actually had less than no register tonnage assigned to them, entirely escaping the payment of many dues although enjoying the privileges of harbours, rivers, &c., and earning large sums by

towing. Examples such as these indicate that some change in the law is required.

As a matter of information it may be added that it is estimated by competent authorities that in the sea-going screw-steamers, where the measured machinery-space falls below 13 per cent. of the gross tonnage, the nett tonnage averages about 77 per cent. of the gross. In the swifter vessels, having machinery space exceeding 20 per cent. of the gross tonnage, the nett tonnage averages about 57 per cent. Individual vessels may, of course, depart considerably from these averages.

Various proposals have been made by the Board of Trade for the purpose of removing these anomalies: and it is but right to add that the officers of that Department have consistently endeavoured to improve the law of 1854, while maintaining its fundamental principle, in the directions indicated by experience of its working. In 1866 the Department issued a circular requesting consideration of a proposal to make the deduction for engine-rooms as follows:—To measure the machinery-space, exclusive of bunkers, and to allow $1\frac{1}{2}$ times that space in all paddle-steamers or $1\frac{3}{4}$ times in all screw-steamers, the total deduction in any case not to exceed 50 per cent. of the gross tonnage, except in tugs. This method was afterwards accepted by the Commissioners for the Danube Navigation, and is usually termed the "Danube Rule"; it was embodied also in a Tonnage Bill submitted to the House of Commons in 1874, but not passed.

Again, in 1867, the Board of Trade submitted for consideration a proposal to measure coal-bunkers as well as machinery-space, and to make the total space thus occupied the allowance for engine room, &c., it being provided that such allowance should not exceed 50 per cent. of the gross tonnage, excepting tugs. This proposal was embodied in the Merchant Shipping Code of 1871, which was introduced into Parliament, but not proceeded with. It was subsequently adopted in Germany, and is now commonly termed the German Rule. This plan is specially applicable to ships with permanent coal-bunkers; but many cargo-carrying steamers are constructed with shifting coal-bunker bulkheads; the space assigned to the coal varying with the quantity required to be carried for the particular voyage, and the space sometimes included in, and at others excluded from, the bunkers being unavailable or available for cargo stowage. Since the nett register tonnage cannot be allowed to vary with the coal-space, some modification of the rule would be necessary

for such cases, and the German Rule only provides for the deduction of fixed bunkers.

The majority of the Royal Commission of 1881 reported in favour of a combination of the Danube and German Rules, with certain modifications, as will appear from the following extract:—"The deduction for propelling-space in steamers should be the actual space set apart by the owner at his discretion for the engine and boiler-room and permanent bunkers, provided that such space be enclosed, separated from the hold of the ship by permanent bulkheads, and that the bunkers be so constructed that no access can be obtained thereto otherwise than through the ordinary coal-shoots on deck or in the ship's side, or from the openings in the engine-room or stokehold; but that to meet the varying requirements as to fuel of steamers engaged in long voyages, and to encourage ample ventilation to boiler and engine-rooms in hot climates, owners of steamers should have the option to claim as deduction for propelling-space the actual contents of engine and boiler-space, plus 75 per cent. thereon in the case of screw-steamers and 50 per cent. in the case of paddle-steamers, without restriction as to extent, construction, and use of bunkers, provided always that the deduction for propelling-space shall not exceed 33 per cent. of the gross tonnage of any screw-steamer, and shall not exceed 50 per cent. of the gross tonnage of any paddle-steamer." It will be remarked that the limit of deduction for screw-steamers is made considerably lower than in the German or Danube Rules, and that clauses are introduced with the intention of preventing cargo from being carried in the permanent bunkers. We do not propose to criticise these recommendations, but would remark that, although they are evidently made with reference to the existing regulations for the Suez Canal and Danube navigation, where an international system of tonnage is in force (see page 58), they differ in the maximum percentage of deduction allowed.

Another proposal, favoured by Mr. Moorsom from the first, was to make the gross tonnage of all ships the legal measurement on which dues should be assessed, allowing no deductions either for crew-space or propelling-space. This method has received the support of many eminent authorities, and has been adopted by the United States. The Suez Canal Company also, at first, attempted to make the gross tonnage the basis for dues, but were over-ruled. Certain dock-charges are now assessed in this country on gross tonnage, but register tonnage is more commonly employed. It is impossible here to enter into a discussion of the justice or

policy of making deductions from the gross tonnage, especially for the machinery and coal-space of steamers, but it is to be observed that the system is now universally established, except in the United States, and that the weight of evidence taken before the recent Royal Commission appears to favour the continuance of that system, and its practically fair operation in association with the existing methods of charging dock and harbour dues. These methods of charging dues might be revised, of course, if the tonnage laws were altered, but the change would, in many cases, involve a considerable amount of new legislation, and is, therefore, not desired by dock-owners.

Apart from these objections to the use of gross tonnage, there are others of perhaps a more serious character, since they relate to the proper mode of estimating the gross tonnage and the determination of the spaces which should be included therein. The meaning of the Act of 1854 was clearly expressed in relation to types of ships then existing; but subsequent changes in ship-construction, and particularly in the erections above the true upper decks of ships, have given rise to new problems in tonnage measurement, and caused many discussions between the Board of Trade and shipowners.* According to the Act, "any permanent closed-in space on the upper deck available for cargo or for stores, or for the berthing or accommodation of passengers or crew," should be measured and included in the gross tonnage. Any shelter-place for deck passengers approved by the Board of Trade was not to be included. In practice, however, the difficulty often occurs that the builders or owners and the Board of Trade officials take different views of the inclusion in, or exclusion from, the gross tonnage of particular erections; and there have been instances where two surveyors of the Board of Trade have treated sister ships differently as regards such erections. Without imputing any improper motive, it may be said that shipowners desire to obtain the greatest carrying capacity and comfort for passengers on the smallest register tonnage. Hence ingenious devices and modifications of previous methods are continually being introduced in the upper works of ships, with the result described above. On the one side it is alleged that the tonnage law is made to operate against provisions for additional comfort or safety; on the other it is asserted that these provisions result in larger earnings, and therefore should add to the tonnage. The

* For particulars of many of these cases see the Appendix to the Minutes of Evidence taken before the Royal Commission of 1881.

majority of the Royal Commission of 1881 proposed to amend the regulations of 1854 as follows:—"Gross tonnage should be made to include all permanently covered and closed-in spaces above the uppermost deck; and erections, with openings either on deck or coverings or partitions that can readily be closed in, should also be included in the gross tonnage; but the skylights of saloons, booby hatches for the crew, light and air-spaces for the boiler and engine-rooms when situated above the uppermost deck, as well as erections for the purposes of shelter, such as turtle-backs open at one end, and light decks supported on pillars and uninclosed, should not be measured for the purpose of their contents forming part either of the gross or register tonnage." These suggestions were evidently made in view of the definitions laid down by the International Commission on Tonnage, which assembled at Constantinople in 1873 to discuss the Suez Canal Rules, viz.:—"By permanently covered and closed-in spaces on the upper deck are to be understood all those which are separated off by decks, or coverings, or fixed partitions, and therefore represent an increase of capacity, which might be used for stowage of merchandise or for the berthing and accommodation of the passengers or the crew." It was also provided in the Suez Canal Rules that "spaces under awning-decks without other connection with the body of the ship than the props necessary for supporting them, and which are permanently exposed to the weather and the sea will not be comprised in the gross tonnage, although they may serve to shelter the ship's crew, the deck passengers, and even merchandise known as deck-loads." This last stipulation is not adopted by the majority of the Royal Commission, who recommend that deck-loads should be dealt with in accordance with the Act of 1876 (see page 47).

Another class of objections to the present system of dealing with light superstructures is represented by the cases of "awning-decked" ships, in which a light covering-deck is built all fore-and-aft, and carried by light bulwarks extending down to the true upper deck. In such vessels it is customary to fix a maximum load-line, and not to load them so deeply in relation to their total depth as would be done if the full scantlings were carried to the uppermost deck. It is asserted that this arrangement is chiefly favoured because it prevents the lodgment of water on the decks, gives a greater freeboard and increased stability, thus adding to the safety as well as the comfort of ships. Further, it is stated that the internal spaces between the awning and upper decks in such ships cannot be fully utilised even when

the lightest cargoes are carried. On these grounds it is maintained that the total internal space is not a measure of the earnings in such ships, but unfairly raises their tonnage upon which dues are paid, as compared with the tonnage of ships in which the erections above the upper deck are discontinuous—such as poops, bridge-houses, forecastles, &c. On the other side it is argued that increased comfort and safety ought to result in larger earnings, and that if the spaces are permanently enclosed there can be no effectual guarantee that cargo or passengers will not be carried above the upper deck. The Board of Trade, therefore, have resisted the endeavour to obtain some reduction of the tonnage of the spaces between upper and awning-decks, and the majority of the Royal Commission of 1881 support this action.

One more illustration must be given of the difficulties arising in the application of the present tonnage laws to modern ships. Water-ballast is now very largely used in merchant ships, and there are various methods of carrying it. One of the plans most approved at present is that illustrated by Fig. 104*a* Chapter IX. In vessels built on this cellular system the double bottom is usually deeper than ordinary floors would be; and the Board of Trade surveyors, in measuring the tonnage of the *Chilka*, built by Messrs. Denny, at first followed the practice established for ships previously built, in which the ballast-tanks were constructed above ordinary floors. That is to say, the surveyors assumed a depth of floor such as would have been used if the ship had been built on the ordinary system, and estimated the under-deck tonnage to this imaginary boundary. This method of procedure was resisted by the builders, and eventually the Board of Trade yielded, the surveyors having since measured all ships constructed on the cellular system to the inside of the ceiling, excluding the ballast-tanks from the tonnage. The difference in measurement by the two methods varies in some cases from $1\frac{1}{2}$ to 2 per cent. of the gross under-deck tonnage as finally measured; a more considerable difference has been produced by modifying the form of the cross-sections, the inner bottom being built with a slight rise towards the bilge, instead of being made level for a considerable breadth athwartships. But while in most of the cellular-bottomed ships the difference in tonnage may have been comparatively trifling, the principle involved is an important one. The majority of the Royal Commission of 1881 support the original action of the Board of Trade in this respect, giving various reasons why the cellular double-bottoms should not be wholly excluded. These reasons need not be reproduced, but it

may be observed respecting the conclusion based upon them that it seems a departure from the fundamental principle on which the Act of 1854 was based, since cargo cannot be carried in cellular double bottoms, except in very special cases—such as those where oil is carried in the ballast-tanks—which might be dealt with in a manner similar to that in which deck cargoes are treated under the Act of 1876. Moreover, the use of an imaginary floor-line for the inner boundary is objectionable, in so far as it involves a virtual interference with structural arrangements, tantamount to treating as a standard a particular method of construction, which is certainly susceptible of improvement, although at present it may be most commonly employed.

Summing up these remarks on the laws at present in force for measuring the tonnage of British ships, it may be stated that the rules laid down by Moorsom for calculating internal capacity have answered their purpose well. They need amendment in some matters of detail, in order that greater accuracy may be secured in dealing with modern ships. It is questionable whether these amendments need be made a matter for legislation, seeing that, since the date when the rules were framed by Moorsom, there has been a great advance in scientific knowledge on the part of persons engaged in shipbuilding. Consequently, if the principle is maintained of making internal capacity the basis of tonnage, the mode of estimating that capacity need not be rigidly prescribed. Moorsom's system would be maintained, with variations in the mode of application to suit particular cases. Correct mensuration of the various spaces having been secured, the difficulties to be encountered include those enumerated above as to water-ballast, superstructures, awning-decks, &c., as well as those relating to deductions for crew-space and propelling-space. The relative importance of those difficulties will be differently appraised by different persons, and will vary in different types of ships. But they represent conditions which will continue to exist in connection with the basis of measurement, although the form in which they appear may change with developments in ship-construction. It appears on a review of the last thirty years, that the operation of the Moorsom system has been favourable, on the whole, to the progress of merchant shipping; and there can be no question but that it is immensely superior to any preceding tonnage law. At the same time the difficulties and anomalies incidental to its operation justify the inquiry whether, having regard to the existing conditions of trade and shipping, some better system cannot now be devised.

To some of the suggestions made for alteration we shall refer hereafter. Before doing so, however, we propose to glance briefly at the use which has been made of the Moorsom system for international purposes and in foreign mercantile marines.*

The first employment of the Moorsom system for international purposes was in connection with the Danube navigation. At first the English law of 1854 was adopted, but subsequently modified as to deductions for propelling and coal-space in the manner described on page 52. The International Commission, which met at Constantinople in 1873, also recommended the Moorsom system for use on the Suez Canal, with certain modifications in the deductions allowed for propelling-space, crew-space, &c.; and certain stipulations as to enclosed spaces which have been quoted on page 55. As the matter is important, the following summary of the Suez Canal rules for tonnage is given:—

The spaces measured for the gross tonnage in all ships are: Space under the tonnage deck; space or spaces between tonnage deck and uppermost deck; all covered or closed-in spaces, such as poop, forecastle, officers' cabins, galleys, cook-houses, deck-houses, wheel-houses, and other inclosed or covered-in spaces employed for working the ship. The deductions permitted in all ships are: Berthing accommodation for the crew in fore-castle and elsewhere—not including spaces for stewards and passengers' servants; berthing accommodation for the officers, except the captain; galleys, cook-houses, &c., used exclusively for the crew; covered and closed-in spaces above the uppermost deck employed for working the ship. In none of these spaces must cargo be carried or passengers berthed, and the total deduction under all these heads must not exceed 5 per cent. of the gross tonnage. In steamers with *fixed* coal-bunkers the German Rule (see page 52) may be followed, or the owners may choose to have their vessels measured by the Danube Rule. Vessels with *shifting* bunkers would be measured by the Danube Rule. In no case, except in tugs, must the deduction for the propelling power exceed 50 per cent. of the gross tonnage; so that the minimum tonnage upon which a vessel can pay dues in passing through the canal is 45 per cent. of her gross tonnage. The actual

* For much information on this subject we are indebted to the able Memoir prepared by MM. Kiaer and Salvessen for the International Statistical Congress (Christiania, 1876). An

excellent summary of rules now in force was also submitted by Mr. Gray, of the Board of Trade, to the Royal Commission of 1881.

average deduction from the gross tonnage of merchant steamers using the canal is estimated at about 30 per cent. Owing to the different methods of making the deductions, a British ship has to pay Suez Canal dues upon a tonnage exceeding by about 10 to 12 per cent. that on which she is assessed in home ports. Warships, as well as merchantmen, use the canal, and have to pay dues. For this purpose all the ships of the Royal Navy are measured by surveyors of the Board of Trade, and furnished with special tonnage certificates. In them the deductions from the gross tonnage vary from 30 to 50 per cent., according to the class of ship. In 1876 the Danube Commission officially adopted the Suez Canal Rules, so that the same certificates are now available for both navigations.

The Moorsom system has now been adopted by all important maritime countries, although the modes of applying it are not identical. In this list appear the United States, Denmark, Austria, Germany, France, Italy, Spain, Sweden, the Netherlands, Norway, Greece, Finland, Russia, Japan and Belgium. As regards gross tonnage there is practical agreement, the only difference being that a few countries include spaces (such as wheel-houses, &c.) necessary for the working of the ships, as is done in the Suez Canal Rules, while the majority do not. For sailing ships, also, the register or nett tonnages closely agree, except for American ships, where there is no deduction for crew-space. For steamers, however, the deductions for machinery-space and coals are not made in the same manner by different countries. In the United States, as has already been stated, there is no deduction. The so-called "German Rule" has been adopted by Germany, Austria, Italy, Norway, Russia and Belgium; while the "Danube Rule" is used by Denmark, Spain, Holland and Greece. The English law is used by Sweden; and in a slightly modified form by France and Finland. M. Kiaer, who has given great attention to the various systems of measurement, makes the following statement as the result of a very extensive analysis.* If the register ton in a steamer, according to the German Rule, be called 100, an English register ton would be called 112, and an American register ton 74. He is of opinion that for statistical purposes the register tonnage of recent English, French, Danish, Swedish, Finnish and Japanese steamships may be considered to have

* See the Memoir mentioned on page 58, and also that on *Les Marines Marchandes*. Christiania: 1881.

identical units: while a similar remark applies to another group including German, Norwegian, Austrian, Italian, Spanish, Russian, Dutch and Belgian ships. These estimates may not be exact, but they cannot fail to be of value in dealing with comparative statistics of shipping.

The principle of the tonnage law of 1854 having been so generally adopted by other maritime countries, by the Suez Canal Company and the Danubian Commission, and the remaining differences being on points of detail, or possibly in the conduct of some of the operations of measurement, it will be evident that a close approach has been made to an international tonnage. This, as the majority of the Royal Commission report, is a weighty argument against any change in the principle on which the law of 1854 is based. The advantages of an international system of tonnage are obvious, and the approximation already made is a great convenience. But, while this is true, it cannot be admitted that there are insuperable difficulties in the way of a change of system in consequence of the general adoption of the existing English system. If an improved system of measurement could be devised free from anomalies and difficulties such as are associated with the Moorsom system, foreign nations would doubtless avail themselves of it. Already very grave objections have been raised by French writers of repute to the adoption of the English laws; and their abandonment has been suggested in favour of other modes of measurement.

The inconveniences attaching to a change of system are sufficiently serious to make it necessary for the advocates of new methods to advance strong arguments, and to defeat hostile criticism of their schemes, before they can hope for success. It is not enough to be able to show that the existing laws involve difficulties, anomalies and inequalities, but the alternative proposals must be shown to be free from similar faults. So far as can be judged from a perusal of the evidence given before the Royal Commission of 1881, although certain amendments are desired in the Act of 1854, particularly as regards the estimates for the register tonnage of steamers, there is no general feeling in favour of an entire change in the basis of measurement. Some authorities whose opinions are entitled to the most careful consideration were in favour of such a change, and we will briefly summarise the principal alternative proposals.

The first is a proposal to return to a *dead-weight* basis of measurement, the earliest mode of assessment (see page 37). Mr. Waymouth, secretary to Lloyd's Registry, and a member of

the Royal Commission, advocates this system in a separate report and his views were endorsed by several professional witnesses. Mr. Waymouth maintains that as the great majority of ships are engaged in carrying cargo and not passengers, the tonnage laws should be especially suitable to them. Freights, as a rule, are now based upon the dead-weight capability of ships; and when light measurement goods are carried, the rates are raised proportionately. In other words, it is asserted that the fundamental principle laid down by Mr. Moorsom (see page 45) no longer holds good; that *internal capacity* in the present conditions of the shipping trade is not the fair measure of the possible earnings of ships under most circumstances, whereas *dead-weight capability* is. This view of the matter is disputed, but the question cannot be discussed here. It may be observed, however, that the special mechanical appliances for packing in small compass many descriptions of light goods, have produced remarkable reductions in the space required for their stowage since the date when Mr. Moorsom wrote; while the change from wood to iron and steel, and the modifications introduced in modern types, have tended to increase the internal capacity available for stowage. Starting from this assumption, Mr. Waymouth proposes to ascertain the *light-line* to which a ship would be immersed when equipped for sea, but without cargo on board. For sailing vessels, no consumable stores are to be on board; for steamers, the engines are to be complete, and the water in the boilers, but no coals are to be on board when the light-line is ascertained. A maximum load-line is to be fixed by some central authority for each ship. The dead-weight capability would then be easily and accurately estimated, being the number of tons of sea water displaced by the ship between her light and load-lines. For passenger ships it is proposed to place the load-lines exactly as if they were cargo ships, and at the maximum height above the keel compatible with safety; although it is admitted that these vessels would never in their regular service load so deeply. The reason given is "that no shipowner will carry light freight, passengers or cattle unless he earns at least as much as if he were carrying a dead-weight cargo."

A "register ton" according to this system would be 20 cwts. avoirdupois, and it may be interesting to inquire how it would be related to the register ton under the existing system. There is, of course, no constant ratio between the two, the relative accommodation assigned to cargo or passengers in different classes of ships, the variations in the relative weights of ma-

chinery in various types of steamers, and other circumstances affecting the ratio. In 1860 Mr. Moorsom gave the following rule:—"To ascertain approximately the dead-weight cargo which a ship can safely carry on an average length of voyage, deduct the tonnage of the spaces appropriated to passenger accommodation from the nett register tonnage, and multiply the remainder by the factor $1\frac{1}{2}$." At present in iron sailing ships the corresponding ratio usually lies between $1\frac{1}{4}$ and $1\frac{1}{2}$; in cargo steamers, $1\frac{3}{4}$ is a fair average, but 2 to $2\frac{1}{4}$ is said to occur. For passenger steamers the ratio of dead weight to nett tonnage varies greatly with differences in the speed as well as in the proportionate importance of cargo and passengers; and in some of the swiftest seagoing vessels is less than unity.

Hence it will appear that difficulties would arise in changing from the present basis to a dead-weight basis, if it were desired for statistical purposes to leave unchanged the nominal aggregate tonnage of the British mercantile marine. This has been considered a matter of some importance in all revisions of the tonnage laws so far made; and Mr. Moorsom chose the divisor 100 in the law of 1854, not merely because of its convenience, but because it closely fulfilled the condition of keeping the aggregate tonnage nearly the same as under preceding rules. Mr. Waymouth does not have regard to this consideration: his system would make the aggregate tonnage considerably greater than at present. It would be possible, no doubt, to keep the aggregate register tonnage of the mercantile marine unchanged, if the labour of determining the total dead-weight tonnage were incurred, and a divisor found expressing the ratio of that total to the present total register tonnage. But it would still remain true, for the reasons given above, that the nominal tonnage of different classes of ships would be very differently affected by the use of this divisor in all cases, because the ratio of the dead-weight capability to the present register tonnage varies so greatly.

The chief difficulties in connection with dead-weight measurement are those relating to the fixing of a maximum load-line in cargo vessels, and the assumptions which have to be made in extending the system to passenger steamers or vessels permanently engaged in trades where light cargoes are the rule. The load-line question has been discussed at page 34; but it is necessary to recall attention to the proposals made by Mr. Waymouth for equitably assessing passenger steamers and vessels carrying light cargoes, because these are the novel features in his scheme. Mr. Waymouth suggests, as has been stated above, giving to these vessels

a load-line deeper than they would ever be sailed at, expressly for the sake of tonnage measurement; and it must be admitted that the suggestion is open to question, because it does not sufficiently recognise the fact that for special services special types of ships are built, some of which cannot be treated as cargo carriers pure and simple, even in fixing a load-line. The majority of the Commission dissent from this recommendation, and object to the association of tonnage legislation with a decision of the many vexed questions involved in fixing the load-line of any class of ship. The latter objection does not seem well grounded, since it is well known that in all recent inquiries into the loading and seaworthiness of ships, the influence of the tonnage laws upon the loading has been discussed; while, on the other hand, in the course of investigations into the working of the tonnage laws, evidence has been freely given as to the load-line and freeboard of ships. Moreover, if it were clearly shown that a dead-weight basis could be fairly applied to all classes, the fixing of a load-line either by the owner or by some central authority would be an essential condition to the practical operation of the scheme; and, being so regarded, it would be done.

No one can fail to remark how the adoption of dead-weight measurement would tend to remove most of the difficulties inherent in measurement by internal capacity. Disputes would no longer arise as to deductions for propelling-space, or water-ballast tanks, or light erections above the upper deck. In all these respects the builders and owners of ships would be left perfectly free. On the other hand, with a dead-weight basis, differences of opinion must be anticipated in fixing the load-line of ships; and, as yet, no thoroughly satisfactory solution appears to have been found of the difficulty experienced in applying that basis to classes of ships which are worked under entirely different conditions.

It may be interesting to add that in the instances where a dead-weight basis has actually been used—excluding coal-laden English vessels (see page 37), the difficulties involved in fixing the load-line have been considerable. The tonnage law of Spain, from 1831 to 1844 was of this character; but it was then changed because of disputes as to the proper load-line. In Finland, until 1877, dead-weight tonnage was used, a certain ratio of freeboard to depth in hold being fixed in estimating the load-line. Here, also, the law has been altered, internal capacity having been substituted for dead weight.

Another method of estimating tonnage by dead weight has

been proposed at different times, but never adopted. The tonnage on which dues were to be paid was to be governed by the number of tons of cargo carried on each voyage; and to assist in ascertaining the dead weight on board, an officially guaranteed "curve of displacement" was to be carried by each vessel (see page 6). It will be seen, therefore, that the tonnage of a ship would be a variable quantity. Moreover, the attempt to assess earnings by the dead weight carried could not possibly succeed, since it leaves almost untaxed the extremely valuable earnings obtained from the carriage of passengers, and treats too favourably the cases where light cargoes are carried. As regards statistical uses this form of dead-weight tonnage would be more objectionable than that described above.

The second proposal for a change in the tonnage law is embodied in a separate report by Mr. Rothery (Wreck Commissioner) who was also a member of the Royal Commission of 1881. It may be shortly described as a proposal to make "displacement tonnage" (see page 43) the basis of all dues. This also is a revival of a proposal made years ago, and, like dead-weight measurement, it requires the fixing of a load-line for each ship, either by the shipowner or by some central authority. We need not repeat what has been said respecting the difficulties attending the fixing of a load-line; but it should be stated that Mr. Rothery contemplates the possibility of leaving this to the discretion of the owner. It is further suggested in his report that, for the purpose of bringing the register tonnage obtained on the new basis into approximate agreement with the present register tonnage, the actual displacement (in tons avoirdupois) should be divided by some factor. Here, however, difficulties must arise, corresponding to those mentioned in connection with the attempt to deal similarly with dead-weight measurement and the present register tonnage. The factor to be used would have very different values in different classes of ships, with different structural arrangements, and different reserves of buoyancy. Even in comparisons between the gross tonnages and the displacements of ships considerable variations occur, due to the wide divergencies in reserves of buoyancy and methods of construction. In ocean-going steamers the gross tonnage may vary from *two-thirds* to *one-half* of the displacement (in tons); in sailing ships between *one-half* and *five-elevenths* of the displacement. When we pass from gross to nett tonnage on the present system, these ratios of tonnage to displacement are very little altered in sailing ships, but very con-

siderably and unequally affected in different classes of steamers, owing to the nature of the deductions for propelling-space. For statistical purposes, therefore, the change to a displacement basis would involve some difficulty in estimating the growth or movements of shipping. This difficulty need not be a bar, however, to a further consideration of the merits or defects of the system.

Mr. Rothery advocates a displacement basis for tonnage, on the grounds that, if the load-line is fixed, the tonnage can be accurately estimated, without difficulties arising as to structural arrangements, propelling-space, erections on deck, &c.; and that this tonnage is the fairest for assessing dock and harbour dues, because it corresponds to the water-space actually occupied. Recognising the fact that in both the Moorsom system and in dead-weight measurement, an endeavour is made to roughly assess the *earnings* of ships, Mr. Rothery contends that the true basis for canal, river, dock and harbour dues is to be found, not in the earnings of ships, but in the *service rendered* to them.* This service is supposed to be represented by the *space occupied* by a ship, represented by her displacement, and by the *time* during which it is occupied. Light dues are treated as of minor importance when compared with dock and harbour dues.

Turning to the objections to this proposal, independently of those connected with fixing the load-line, it must first be noticed that the displacement is not a fair measure of the space required by a ship. That space is more fairly measured by the parallelopipedon of which the length equals the length of the ship "over all," the breadth is her extreme breadth, and the depth her mean draught, unless she trims excessively by the stern. For it is evident that if these three leading dimensions are the same, the possibility of berthing other ships in a dock or harbour is not altered by variations in the "coefficient of fineness" for displacement (see page 3). And we have seen that the coefficients of fineness may vary from 70 down to 40 in ships of different classes, but with the same extreme dimensions.

Next, it is said that a displacement basis would furnish strong inducements to the construction of excessively light hulls and

* The reader interested in this subject may turn with advantage to the evidence given by Mr. Farrer, Secretary to the Board of Trade, before the House of Commons Committee on the

Tonnage Bill of 1874, where this distinction between the two systems of taxation is admirably stated and illustrated.

engines, in order that on a given displacement the greatest dead-weight carrying power might be secured. There is force in this argument, but it applies with practically equal force to ships built to carry dead-weight cargoes under the present tonnage law. And the tendency to undue lightness of construction must always be kept in check by careful surveys, such as are made on nearly all merchant ships by officers of the great registration societies.

A third proposal put before the Royal Commission was to base dock-dues, &c., upon either the area of the rectangle having the length over all and breadth extreme of a ship, or upon the volume obtained by multiplying that area by the mean draught. This class of proposal will be seen to approximate to that made by Bouguer in 1746 (see page 38). It is not favoured by the majority of the Commission, chiefly because of the adverse opinions of dock authorities. It has also been stated that such a system might bring back box-shaped unseaworthy vessels, resembling those built under the B.O.M. rule. On the other hand it must be admitted that the circumscribing parallelepipedon is the fairest measure of the space occupied; and if the dues of docks, harbours and canals were adjusted to include both this space and the time it was occupied, the arrangement would be fair on both sides. There may be objections to the adjustment of dock and other dues, but the difficulties of the operation cannot be so great as to prevent it from being undertaken if there were a general feeling that a radical change was needed in the tonnage system. Furthermore, it must be remarked that the parallelepipedon system may be applied either to the actual mean draught of a ship when she enters a dock, in which case the tonnage for dues would be variable; or to a maximum load-line, fixed by the owner as at present, or fixed by some central authority. Should the latter action be taken, as it may be, then the fear as to the reproduction of box-shaped vessels is clearly groundless, for the central authority would not fail to have regard to the form in fixing the load-line. Apart from this action, there is no good reason for believing that shipowners would sacrifice speed, economy under steam, and good behaviour at sea simply for the purpose of increasing the ratio of the dead weight carried to the nominal tonnage and lessening the dock-dues.

On all these grounds it seems desirable that if any radical change should be made in the tonnage laws, the parallelepipedon system should receive further consideration. Its adoption would introduce difficulties in connection with statistical statements of

the growth and movements of shipping, resembling those described above for a dead-weight or displacement basis; but in neither case do these difficulties appear insuperable.

A few words will suffice respecting another kind of tonnage measurement commonly employed in the mercantile marine. *Freight tonnage* is simply a measure of cubical capacity. Merchants and shipowners make considerable use of this measurement, although it has no legal authority; it is also used in the Admiralty service in connection with store-ships and yard-craft. A freight-ton, or "unit of measurement cargo," simply means 40 cubic feet of space available for cargo, and is therefore two-fifths of a register ton. Mr. Moorsom says that for an average length of voyage the nett register tonnage, less the tonnage of the passenger space, when multiplied by the factor $1\frac{7}{8}$, will give a fair approximation to the freight-tons for cargo stowage. This rule has the same basis as that for dead-weight cargo given above. In some cases the internal capacity of a ship available for freight is expressed in tons of 50 cubic feet, this unit having especial reference to import goods, and the preceding one to goods exported. The freight-ton is, of course, a purely arbitrary measure, but has a definite meaning, and is of service in the stowage of ships.

The tonnage of yachts is measured by special rules, chiefly for the purposes of regulating time-allowances in racing; and so many persons are interested in the subject that it appears desirable to devote some attention to it here. The Thames rule, which has hitherto been most generally adopted in this country, is as follows:—

(a) The length is measured on the deck from the fore part of the stem to the after part of the sternpost (CD in Fig. 27, page 39); let this be called L.

(b) The breadth is measured to the outside of the outside plank at the broadest part wherever found; let this be called B.

(c) From the length the breadth extreme is deducted, the remainder being the "length for tonnage." This length for tonnage is multiplied by the breadth, and their product by half the breadth; the result divided by 94 gives the tonnage. In algebraical language,

$$\text{Tonnage (Thames measurement)} = \frac{(L - B) \times B \times \frac{B}{2}}{94}.$$

As an example, take the case of a yacht for which the length (L) is 102 feet; breadth extreme (B) 21 feet.

$$\begin{aligned} \text{Tonnage (Thames measurement)} &= \frac{(102 - 21) \times 21 \times \frac{21}{2}}{94} \\ &= \frac{81 \times 21 \times 21}{94 \times 2} = 190 \text{ tons.} \end{aligned}$$

These modifications of the B.O.M. rule are not of any great importance, except that the measurement of the length along the deck, instead of along the keel, does away with any motive to rake the sternpost excessively in order to decrease the nominal tonnage. In other respects the objections urged above to the B.O.M. rule apply here; but there is one important exception. Yachts are measured mainly for time-allowance in racing, and the owner has not the same inducements to malform the vessel in order to give her increased carrying power which the owner of the cargo-carrying vessel had. The yachtsman seeks to secure speed, and for that purpose favours good proportions and considerable stability.

Prior to the present year (1882) the Yacht Racing Association used a slight modification of the Thames rule. The length was measured from out to out on the load-line, it being provided that "if any part of the stern or sternpost or other part of the vessel below the load water-line project beyond the length taken as mentioned, such projection or projections shall, for the purposes of finding the tonnage, be added to the length taken as stated."

These rules put a severe penalty on beam as compared with length; and, since they took no account of depth, designers were not slow to avail themselves of the possibility afforded them to use large weights of ballast placed low down for the purpose of securing large sail-carrying power on vessels of great length, small beam and small nominal tonnage. It is admitted that this deep, narrow type of vessel is practically uncapsizable and very well-behaved at sea (see Chapter III.). It is also claimed for the Thames Rule, and its modification, that it brought the type of yacht built specially to sail under it into fair competition with other types of yachts, such as the American, built to sail under other tonnage rules. Furthermore it appears that the Thames Rule approximately expressed the sail-carrying power of yachts (see Chapter XII.). But notwithstanding all these considerations, and the dislike of many yachtsmen to a change of rule, the Yacht Racing Association have introduced a new system of

measurement, designed especially to check the tendency to greater and greater length, narrower beam and more ballast in yachts of different classes.

The Yacht Racing Association rule of 1882 measures the length and breadth as before, and expresses the tonnage by the equation :

$$\text{Tonnage} = \frac{(\text{Length} + \text{Breadth})^2 \times \text{Breadth}}{1730}$$

A fraction counts as a ton. The divisor has been so chosen as to keep the tonnage of existing yachts very nearly the same as under the previous rule. It will be observed that no actual measurement of depth appears in the amended rule, which is in this respect no improvement upon its predecessors. Notwithstanding its purely empirical character it may answer its intended purpose fairly well, as it was devised by some of the most eminent authorities on yacht sailing.

Besides these rules for yacht-tonnage there are many others which have been proposed or employed to a limited extent. None of these are free from objection, but a few of the principal alternative rules may be described. In 1874 the Corinthian and New Thames Yacht Clubs adopted the following rule for a short time, but eventually abandoned it, in consequence of the objections raised by yachtsmen :

$$\text{Tonnage} = \frac{\text{Length} \times \text{Breadth} \times \text{Depth}}{200}$$

In this rule the length and breadth for tonnage were measured as in Thames measurement, the depth being the *total depth* up to the top of the covering board. One obvious objection to the use of the total depth is that owners desiring to decrease the nominal tonnage would be tempted to decrease the height out of water to an objectionable, although not to a dangerous, extent.

Displacement tonnage has been advocated for British yachts, and was formerly in use for American yachts. It is urged in favour of this mode of measurement that it would bring yachts into the same category as other classes of ships, for which economical propulsion is measured by the power required to drive a given weight at a given speed. Also that the designer would then have absolute freedom in choosing forms and proportions. On the other hand it is argued that displacement tonnage favours the construction of mere "racing machines," vessels broad in relation to length, with shallow hulls, deep keels and small range

of stability, although exceedingly stiff (see Chapter III.). These objections are emphasised by reference to the yachts actually built in America to sail under displacement rules, which had very small displacement in proportion to their extreme dimensions, great "stiffness," large sail-areas, and high speed in smooth water, but which proved inferior to the English type of yachts when sailing in strong winds and heavy seas. This displacement rule has now been abandoned in America, and there is no probability of its adoption in this country. Minor objections to its use have been raised on the grounds that variations in the amount of ballast carried at different times would necessitate variations in time-allowance; also that many owners would object to having their yachts measured accurately, fearing that their forms might be reproduced or improved upon. Little weight attaches to these objections, however, as compared with those stated above.

Another proposal which has found much favour, and has even been temporarily adopted, is to base time-allowances upon the *sail-areas* of yachts. One of the strongest advocates of this method uses the following arguments:—"If, with smaller sails, we outsail our rival, who can say that an improvement in the form of the vessel is not the cause? we have given the owner a yacht of equal size and greater velocity." Further, it is asserted as an observed fact that, when two well-designed yachts of dissimilar forms are sufficiently near to equality of size to permit of competitive sailing, their speeds will be about equal under most conditions, if the sail-spreads are of equal area. A very common practice has been to proportion the total sail-spread of yachts to the area of the load water-plane, or to the product of the extreme length and breadth of that plane. The New York Yacht Club, therefore, formerly based time-allowances upon the product of these two extreme dimensions, instead of upon sail-area, which would have involved greater difficulties in measurement. It will be observed, however, that the reasoning upon which the proposal is based takes account of size or displacement as well as sail-areas; and that some definite regulation would be needed as to the "classes" in which yachts should be ranged for competitive sailing. Hence would arise considerable difficulty in practically applying the proposal.

Some eminent authorities in yacht-construction have favoured the determination of time-allowances on the basis of the "sail-carrying powers." It is clearly of the greatest importance to the speed of yachts that they should be capable of "standing-up" under their canvas; but before any rule of this kind could

be used much more care would have to be bestowed upon the exact determination of the stability of yachts than is now common.

Other methods for estimating yacht-tonnage for time-allowances proceed on the assumption that the length, or some function of the length, should be the basis of measurement. Rules of this kind have been used in America, but in this country they have been applied only to boats or small yachts. External bulk, measured to the top of the upper deck planking, has also been used in America and advocated here. Another proposal has been to use the register (or fiscal) tonnage of yachts—a measure of their internal capacity. This last suggestion is simple, as all yachts are measured by surveyors of the Board of Trade for their register tonnage. On the other hand, variations in the structures of yachts, affecting the thicknesses of their sides, would make the “register tonnage” a very unfair comparison of their external bulk; and there would be a temptation to decrease the freeboard, in order to lessen the tonnage, whether measured by internal capacity or by accurate determination of the outside shape. Besides these various rules there are many others in force, for small boats, canoes and yachts. Space fails, however, for the further discussion of this interesting subject; and it must suffice to add that each rule tends to produce its special type of vessel, adapted to derive the greatest advantage by the combination of small nominal tonnage with large driving-power.*

In concluding this chapter a short statement may be made of the various kinds of tonnage measurements actually in use, which have been described in the preceding pages:—

- (1) Displacement tonnage.
- (2) Financial tonnage (Navy Estimates).
- (3) Builders Old Measurement, with its modifications in Thames measurement for yachts.
- (4) Register tonnage.
- (5) Freight tonnage.

Besides these, descriptions have been given of other systems of tonnage, which are either applied to a limited extent (as in yacht and boat sailing) or else not used. Some of these “tons” repre-

* The reader desirous of pursuing the subject further will find a full discussion of existing tonnage-rules used

in estimating time-allowances in Mr. Dixon Kemp's valuable *Manual of Yacht and Boat Sailing*.

sent dead weight, others represent "capacity," and the B.O.M. or Thames Rules, are empirical measures, representing neither weight nor capacity in most cases. With such a variety of measures and so many kinds of "tons," careful discrimination is obviously needed to prevent mistakes when dealing with the tonnage of ships.

CHAPTER III.

THE STATICAL STABILITY OF SHIPS.

A SHIP floating freely and at rest in still water must fulfil two conditions: first, she must displace a weight of water equal to her own weight; second, her centre of gravity must lie in the same vertical line with the centre of gravity of the volume of displacement, or "centre of buoyancy." In the opening chapter the truth of the first condition was established, and it was shown that the circumstances of the surrounding water were unchanged, whether the cavity of the displacement was filled by the ship or by the volume of water displaced by the ship. When the ship occupies the cavity, the whole of her weight may be supposed to be concentrated at her centre of gravity, and to act vertically downwards. When the cavity is filled with water, its weight may be supposed to be concentrated at the centre of gravity of the volume occupied (i.e. at the centre of buoyancy), and to act vertically downwards; the downward pressure must necessarily be balanced by the equal upward pressures, or "buoyancy," of the surrounding water; therefore these upward pressures must have a resultant also passing through the centre of buoyancy. In Fig. 28, a ship is represented (in profile and transverse section)

FIG 28

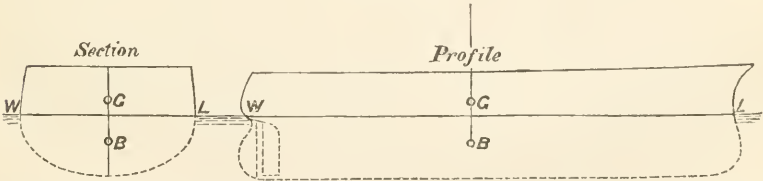

floating freely and at rest in still water. Her total weight may be supposed to act vertically downwards through the centre of gravity G; the buoyancy acting vertically upwards through the centre of buoyancy B. If (as in the diagram) the line joining the centres G and B is vertical, it obviously represents the

common line of action of the weight and buoyancy, which are equal and opposite vertical forces; in that case the ship is subject to no disturbing forces, and remains at rest, the horizontal fluid pressures which act upon her being balanced amongst themselves. But if (as represented in Fig. 29) the centres

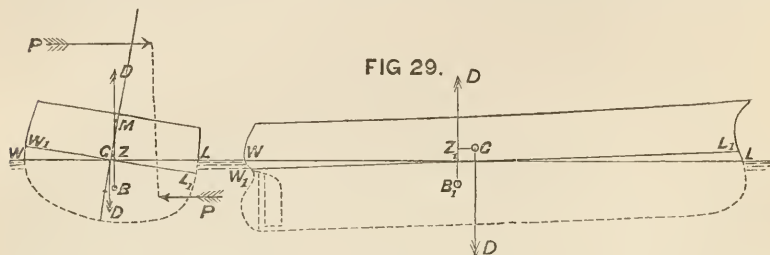

G and B are not in the same vertical line, the equal and opposite forces of the weight and buoyancy do not balance each other, but form a "mechanical couple," tending to disturb the ship, either by heeling her or by producing change of trim or causing both these changes. If D = total weight of the ship (in tons), and GZ = perpendicular distance between the parallel lines of action of the weight and buoyancy (in feet),

$$\text{Moment of couple} = D \times GZ \text{ (foot-tons).}$$

If the vessel is left free to move from this position, not being subjected to the action of external forces other than the fluid pressures, she will either heel or change trim, or both heel and change trim until the consequent alteration in the form of the displacement brings the centre of buoyancy into the same vertical with the centre of gravity G . It is important to note that, for any specified distribution of weights in a ship, supposing no change of place in those weights to accompany her transverse or longitudinal inclinations, the centre of gravity is a *fixed point in the ship*, the position of which may be correctly ascertained by calculation. On the contrary, the centre of buoyancy varies in position as the ship is inclined, because the form of the displacement changes. Hence, in treating of the stability of ships, it is usual to assume that the position of the centre of gravity is known, and to determine the place of the centre of buoyancy for the volume of displacement corresponding to any assigned position of the ship. The value of the "arm" (GZ) of the mechanical couple formed by the weight and buoyancy can then be determined. If it is zero, the vessel floats freely and at rest, in other words, occupies a "position of equilibrium;" if

the arm (GZ) has a certain value, the moment of the couple ($D \times GZ$) measures the effort of the ship to change her position in order to reach a position of equilibrium. In this latter case the vessel can only be retained in the supposed position (see Fig. 29) by means of the action of external forces; and if her volume of displacement is to remain the same as when she floats freely, these external forces must also form a mechanical "couple" the equal and opposite forces acting in parallel lines. For example, suppose a ship to be sailing at a steady angle of heel, and the resultant pressure of the wind on the sails to be represented by the pressure P in Fig. 29 (section) acting along a horizontal line. When the vessel has attained a uniform rate of drift to leeward, the resistance of the water will contribute a pressure, P , equal and opposite to the wind-pressure; and if d be the vertical distance between the lines of action of these pressures, we have

$$\left. \begin{array}{l} \text{Moment of couple formed by} \\ \text{horizontal forces} \end{array} \right\} = P \times d \text{ (foot-tons) ;}$$

which moment will be balanced by that of the couple formed by the weight and buoyancy. Hence

$$D \times GZ = P \times d,$$

is an equation enabling one to ascertain the angle of steady heel for a particular ship, with a given spread of sail, and a certain force of wind. Its use is illustrated in Chapter XII.

Supposing a ship, when floating upright and at rest, to be in a position of equilibrium, which is the common case: let her be inclined through a very small angle from the initial position by the action of a mechanical couple. If, when the inclining forces are removed, she returns toward the initial position, she is said to have been in *stable equilibrium* when upright; if, on the contrary, she moves further away from the initial position, she is said to have been in *unstable equilibrium* when upright; if, as may happen, she simply rests in the slightly inclined position, neither tending to return to the upright nor to move from it, she is said to be in *neutral or indifferent equilibrium*. A well-designed ship floats in stable equilibrium when upright; but many ships, when floating light, without cargo or ballast, are in neutral or in unstable equilibrium when upright, and consequently "loll over" to one side or the other when acted upon by very small disturbing forces. Damage to the skin of a ship which was in stable equilibrium when intact, and the entry of water into the hold may also produce unstable or

neutral equilibrium in the upright portion. It will be shown hereafter that there is a marked distinction between such instability and the conditions which lead to the capsizing of ships.

The *statical stability* of a ship may be defined as the effort which she makes when held steadily in an inclined position by a mechanical couple to return towards her natural position of equilibrium—the upright—in which she rests when floating freely. This effort, as explained above, is measured by the moment of the couple formed by the weight and buoyancy. Hence we may write, for any angle of inclination,

$$\text{Moment of statical stability} = D \times GZ.$$

But in doing so, it must be noted that in all ships, angles of inclination may be attained for which the line of action of the

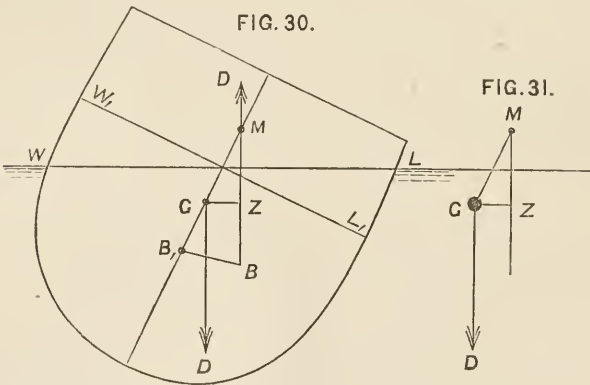

buoyancy, instead of falling to the right of G (as in section, Fig. 30), and so tending to restore the ship to the upright, will fall to the left and tend to *upset* her or make her move away from the upright position. This matter will be more fully explained hereafter.

Starting from the upright, a ship may be inclined transversely, or longitudinally, or in any "skew" direction lying between the two. It is only necessary, however, to consider transverse and longitudinal inclinations in connection with statical stability; the innumerable possible skew inclinations being easily dealt with when the conditions of stability for the two principal inclinations have been ascertained. The *minimum* stability of a ship corresponds to transverse inclinations; the *maximum* stability, to longitudinal inclinations. It is, therefore, of the greatest importance to thoroughly investigate the changes in

the statical stability of ships as they are heeled to greater and greater transverse inclinations, especially for ships which have masts and sails. Longitudinal stability is less important, but claims some notice, especially as regards its influence on changes of trim and pitching motions.

Taking first transverse inclinations, let them be supposed to be small; it is then easy to estimate the statical stability when the position of the *metacentre* is known. For our present purpose the metacentre may be defined, with sufficient exactitude, as the intersection (M in the cross-section, Fig. 30) of the line of action (BM) of the buoyancy when the ship is inclined through a very small angle, with the line of action (BGM) of the buoyancy when the ship is upright and at rest. In vessels of ordinary forms, no great error is introduced by supposing that, for angles of inclination between the upright and 10 or 15 degrees, all the lines of action of the buoyancy (such as BM) pass through the same point (M)—the metacentre. For any angle of inclination α within these limits the perpendicular distance (GZ) of the line of action of the buoyancy from the centre of gravity is determined by—

$$GZ = GM \sin \alpha.$$

Hence by what is usually termed the “metacentric method,” it follows that—

$$\text{Moment of statical stability} = D \times GM \sin \alpha.$$

As an example, take a ship weighing 6000 tons, for which the distance $GM = 3$ feet, and suppose her to be steadily heeled under canvas at an angle of 9 degrees. Then

$$\begin{aligned} \text{Moment of statical stability} &= 6000 \text{ tons} \times 3 \text{ feet} \times \sin 9^\circ \\ &= 18,000 \times \cdot 1564 = 2815 \text{ foot-tons.} \end{aligned}$$

For most ships the angles of steady heel under canvas lie within the limits for which the metacentric method holds; and consequently this method may be used in estimating the “stiffness” of a ship, i.e. her power to resist inclination from the upright by the steady pressure of the wind on her sails. It must be noticed that this term “stiffness” is used by the naval architect in a sense distinct from “steadiness.” A *stiff* ship is one which opposes great resistance to inclination from the upright, when under sail or acted upon by some external forces; a *crank* ship is one very easily inclined; the sea being supposed to be *smooth and still*. A *steady* ship, on the contrary, is one which, when exposed to the action of waves in a seaway, keeps nearly upright, her decks not departing far from the horizontal. Hereafter it

will be shown that frequently the *stiffest* ships are the *least steady*, while crank ships are the steadiest in a seaway. At present we are dealing only with still water, and must limit our remarks to stiffness.

From the foregoing remarks it will be evident that, so far as statical stability is concerned, and within the limits to which the metacentric method applies, a ship may be compared to a pendulum, having its point of suspension at the metacentre (M, Fig. 30), and its weight concentrated in a "bob" at the centre of gravity G. Fig. 31 shows such a pendulum, held steadily at an angle a . The weight (D) acting downwards produces a tendency to return to the upright, measured by the moment $D \times GM \sin a$, which is identical with the expression for the righting moment of the ship at the same angle. But this comparison holds only while the ship and the pendulum are at rest; as soon as motion begins, the comparison ceases to be correct, and the failure to distinguish between the two cases has led some writers into serious error. If the centre of gravity of the ship lies *below* the metacentre, she tends to return towards the upright when inclined a little from it; that is, her equilibrium is *stable*. If the centre of gravity of the ship lies *above* the metacentre, she tends to move away from the upright when slightly inclined; that is, her equilibrium is *unstable*. If the centre of gravity coincides with the metacentre, and the ship is inclined through a small angle, she will have no tendency to move on either side of the inclined position, and her equilibrium is *indifferent*. The metacentre, therefore, measures the height to which the centre of gravity may be raised, without rendering the vessel unstable when upright; and it was this property which led Bouguer, the great French writer to whom we owe the first investigations on this subject, to give the name, metacentre, to the point.

Changes in the height (GM) of the metacentre above the centre of gravity produce corresponding changes in the stiffness of a ship; in fact, the stiffness may be considered to vary with this height—usually termed the "metacentric height." If it is doubled, the stiffness is doubled; if halved, the stiffness is reduced by one-half, and so on. Care has, therefore, to be taken by the naval architect, in designing ships, to secure a metacentric height which shall give sufficient stiffness, without sacrificing steadiness in a seaway. In adjusting these conflicting claims, experience is the best guide. The following tables contain particulars of the metacentric heights of different classes of war-vessels, the vessels being fully laden.

It is to be noted that the first five groups in this table include *sailing* ironclads. Experience has led to the selection of metacentric heights of from 3 to 4 feet as the best suited for such

Ironclads.	Metacentric Height (GM).
	Feet.
1. Converted frigates (formerly two-deckers); <i>Prince Consort</i> class in Royal Navy, and earliest French frigates (<i>Gloire</i> class)	6 to 7
2. <i>Warrior</i> and <i>Minotaur</i> classes in Royal Navy; <i>Flandre</i> class in French navy	4 „ 4 $\frac{3}{4}$
3. Broadside ships with central batteries such as <i>Bellerophon</i> , <i>Hercules</i> , or <i>Alexandra</i> in Royal Navy	2 $\frac{1}{2}$ „ 3 $\frac{1}{2}$
4. <i>Marengo</i> class in French navy	1 $\frac{1}{2}$ „ 2 $\frac{1}{4}$
5. <i>Alma</i> class of corvettes in French navy	3
6. <i>Devastation</i> class of Royal Navy	3 $\frac{1}{2}$ „ 4
7. <i>Glatton</i> (low freeboard monitor)	About 7
8. <i>Garde-côtes</i> (<i>Bélier</i> class), French navy	„ 7 $\frac{1}{2}$
9. <i>Inflexible</i> (central citadel iron-clad)	„ 8 $\frac{1}{4}$
10. American type of monitor (<i>Miantonomoh</i>)	„ 1 $\frac{1}{2}$

vessels, taking into account their ordinary spread of canvas. The remaining groups comprehend mastless ships, in which the greater metacentric heights are often unavoidable with the forms and proportions rendered necessary by the special conditions of the designs—such as moderate draught in association with thick armour and heavy guns, or the necessity for providing against possible losses of stability due to damage in action.

Unarmoured Ships.	Metacentric Height (GM).
	Feet.
1. Coast defence, and river service gunboats	From 7 to 12
2. Screw line-of-battle ships (two deckers), of which a few remain in the French and Royal navies	„ 4 $\frac{1}{2}$ to 6 $\frac{1}{2}$
3. Screw frigates and corvettes of the old types	„ 4 „ 5
4. Screw frigates of new type and very high speed, such as <i>Inconstant</i> class of Royal Navy, or <i>Tourville</i> of French navy	„ 2 $\frac{1}{2}$ „ 3
5. Screw corvettes and sloops of recent design	„ 2 $\frac{3}{4}$ „ 3 $\frac{1}{2}$
6. Smaller classes of sea-going vessels	„ 2 $\frac{1}{4}$ „ 3
7. Tugs, torpedo-boats and small vessels, not sea-going	„ 1 „ 2

When the consumable stores of these vessels, armoured and unarmoured, are removed, the metacentric heights are frequently from six inches to one foot less than in the fully laden condition to which the tables refer; but there are many cases in which the decrease in metacentric height due to such lightening is greater than one foot, and there are others in which lightening is accom-

panied by no loss or even by a gain of stiffness. This will be explained hereafter.

Corresponding particulars of the metacentric heights of steamships belonging to the mercantile marine are very scanty. Until recently few attempts were made to obtain exact data on the subject; and for the fully-laden condition of any ship variations in stowage necessarily produce variations in stiffness. The designer obviously has no control over the stowage, which is chiefly in the hands of stevedores who regulate their procedure by practical rules deduced from experience. In this respect, therefore, the designs of war-ships and merchant ships differ widely; the naval architect assigns definite positions to all the weights carried in the war-ship, and can aim at a definite amount of stiffness; whereas the stiffness of the merchant ship, when laden, is practically governed by an ever-varying stowage of cargo. So far as the facts on record enable a judgment to be formed it appears that metacentric heights in fully laden merchant steamers frequently lie between $1\frac{1}{2}$ and 3 feet: sometimes falling to 6 or 8 inches and at others exceeding 3 feet. A large ocean-going steamer, for example, having a high reputation for speed and good behaviour was found to have a metacentric height of $1\frac{1}{2}$ feet. Cargo-carrying steamers, laden with grain or other homogeneous cargoes, have been found to have metacentric heights of seven-tenths or eight-tenths of a foot; whereas other vessels have had metacentric heights of from $1\frac{1}{2}$ to 2 feet under similar conditions of lading.* Homogeneous cargoes are generally regarded as those which least favour stiffness with a given dead weight; and there are many merchant steamers which could not carry such cargoes without some ballast, although in actual service with miscellaneous cargoes they are never ballasted. Not a few instances occur where the amount of stiffness given to merchant ships by improper stowage of heavy dead-weight cargoes proves too great and leads to heavy rolling at sea.

Under the circumstances explained above it is not surprising to find that private shipbuilders have hitherto paid but little attention to exact investigations of the initial stability of merchant ships except in special cases. A considerable amount of attention has, however, been given to the subject recently, and experiments have been made by many of the leading private

* For much valuable information as to the stability of cargo steamers, see a paper in vol. xxi. of the *Transactions*

of the Institution of Naval Architects, by Mr. Martell (chief surveyor at Lloyds).

firms to determine the metacentric heights of ships of various classes, and there is reason to hope that the practice will become general. From the designer's point of view interest chiefly centres in the condition of ships when floating light with no weights on board other than those belonging to hull, equipment or machinery. Having ascertained the vertical position of the centre of gravity for this condition, it is an easy matter to approximate to the change in that position produced by putting any weights on board, and thus to estimate the "metacentric height" for a given stowage of dead weight. This will appear more clearly from the explanations given hereafter (page 93). Confining attention for the present to the *light condition* of merchant steamers, the following table will be of some interest, containing as it does results deduced from experiments made to determine the actual stiffness of a number of vessels of various classes.*

It will be remarked from the table that there are very considerable differences in the stiffness, as well as in the vertical position of the centre of gravity (in relation to the total depth) of different ships. Many of these vessels are sufficiently stiff, when floating light, to permit of their being shifted from berth to berth in port without requiring ballast. Others are so stiff that they might, as far as this quality is concerned, be safely trusted from port to port with little or no ballast. Others, on the contrary, require to be ballasted in order that they may stand upright without cargo; although when fully laden they may have sufficient metacentric heights without ballast. Some of the steamers in this last category are worked without ballast, coals being shipped as cargo is discharged in order to preserve sufficient stiffness; while others use water-ballast as the most convenient method of meeting the requirements of the case, and others of older type require rubble-ballast, or pig-iron, to be put on board as cargo is discharged. The explanatory notes attached to the table will enable the effect of forecastles, poops and deck-houses upon the vertical position of the centre of gravity to be traced, as well as the influence of differences in the rig or structure of various ships. For purposes

* For many of the facts in this table the author is indebted to gentlemen connected with some of the leading private shipbuilding firms—including Messrs. Laird, of Birkenhead, Messrs. Denny, of Dumbarton, Messrs. A. and

J. Inglis, of Glasgow, Messrs. R. Napier & Sons, of Glasgow. The remaining examples are taken from the results of inclining experiments made on mercantile steamers bought into the Royal Navy.

TABULAR STATEMENT OF THE RESULTS OF INCLINING

Reference Number.	Length between Perpendiculars.	Breadth, extreme.	Depth from Upper Side of Keel to Top of Upper-deck Beam at side amidships (D).	Experimental Data for Ships Floating Light, with Water in Boilers, but no Cargo or other Dead Weight on Board.				
				Mean Draught.	Displacement.	Meta-centric Height (G M).	Height of Centre of Gravity above Top of Keel (h).	Ratio, h : D.
	Feet ins.	Feet ins.	Feet.	Feet ins.	Tons.	Feet.	Feet.	
1	440·0	46·0	36·25	13·2	4570	- 1·0	22·5	·62
2	350·0	44·6	34·5	18·8	4240	1·2	20·5	·594
3	390·0	39·0	30·8	13·6	3200	- ·7	17·9	·58
4	340·0	46·2	34·0	16·6	3140	2·3	20·	·588
5	320·0	40·0	28·5	9·7	2110	2·9	18·	·63
6	320·0	40·0	22·7	11·5	1900	5·2	15·8	·696
7	320·0	34·0	26·5	11·4	1880	- 1·25	17·	·64
8	313	33·6	25·5	11·6	1760	·2	15·4	·6
9	285·0	35·0	26·5	9·10	1610	2·1	14·85	·56
10	290·0	34·0	25·8	9·2	1530	1·5	14·9	·577
11	290·0	32·0	16·6	10·3	1410	2·4	12·7	·765
12	264·0	32·0	23·	8·11	1240	1·5	14·5	·63
13	253·0	33·2	26·3	9·10	1130	2·	14·1	·536
14	234·0	29·0	19·6	10·6	1100	1·5	11·2	·57
15	195·0	29·2	18·0	12·11	1040	1·3	12·	·67
16	227·0	28·0	20·6	8·9	860	·7	11·9	·577
17	210·0	28·0	15·0	9·4	780	·83	11·5	·77
18	220·0	27·6	22·0	9·0	780	- ·3	12·8	·58
19	220·0	30·0	22·5	8·3	750	1·8	12·7	·565
20	200·0	26·0	13·9	8·5½	630	1·8	10·4	·75
21	178·0	27·0	20·0	9·6	600	1·4	11·5	·575
22	125·0	20·0	9·5	4·9	180	3·2	7·4	·78
23	60·0	12·0	6·3	3·11	32	1·8	4·3	·68

EXPERIMENTS MADE ON VARIOUS TYPES OF MERCHANT STEAMSHIPS.

Reference Number.	REMARKS.
1	{ Trans-Atlantic mail steamer; new type; cellular double bottom; large deck-houses; light rig.
2	{ Mail steamer (old type); good speed; good sail-spread; fore-castle, poop, and deck-houses; 180 tons of permanent ballast.
3	{ Cargo and passenger steamer; good speed; light rig; deck-houses and turtle covers at ends.
4	Same type as (2); with 75 tons of permanent ballast; deck-houses only.
5	{ Cargo and passenger steamer; good speed; light rig; poop and fore-castle; continuous double bottom.
6	{ Cargo and passenger steamer; good speed; light rig; awning deck, and heavy deck-houses.
7	{ Cargo steamer; moderate speed; light rig; turtle covers at ends, and deck-houses; water-ballast tank above ordinary floors.
8	Passenger and cargo steamer; high speed; light rig; deck-houses.
9	{ Cargo steamer; moderate speed; light rig; fore-castle and deck-houses; continuous double bottom.
10	Ditto ditto ditto.
11	Passenger steamer (paddle-wheel); high speed; light fore-castle and full poop.
12	Cargo steamer; low speed; light rig; flush deck.
13	Ditto ditto.
14	{ Cargo and passenger steamer; moderate speed; light rig; fore-castle, poop, and deck-house.
15	{ Armed sloop; composite built; good speed; full rig; light armament; 150 tons of permanent ballast.
16	{ Cargo and passenger steamer; moderate speed; brig rig; awning deck and deck-houses above.
17	{ Cargo and passenger steamer; moderate speed; moderate rig; fore-castle, poop, and deck-houses.
18	Cargo steamer; moderate speed; light rig; deck-houses.
19	Ditto ditto.
20	{ Cargo and passenger (Channel service); good speed; light rig; poop, fore-castle, and deck-house.
21	Cargo steamer; low speed; light rig; deck-houses; 80 tons of ballast.
22	Cargo boat; low speed; light rig; fore-castle and raised quarter-deck.
23	Steam-launch.

of guidance in design fuller details would be required than are here given; in order that a new ship might have the position of her centre of gravity determined approximately by comparison with a completed ship of which the stiffness had been ascertained. But, for our present purpose, the particulars given will suffice, and the extension of the practice of inclining ships to determine the position of the centre of gravity promises to become so general that the facts given in the table will probably be supplemented ere long by much valuable data of the same kind.

Passing from steamers to sailing ships a brief summary may be given of the recorded *data*, as to their metacentric heights, and initial stability. Very few experiments were made on the older class of sailing war-ships in the Royal Navy; but from these experiments, and from careful estimates made by naval architects of the period, it appears that, when fully laden, these ships had metacentric heights of from $4\frac{1}{2}$ to $6\frac{1}{2}$ feet; and when light about $1\frac{1}{2}$ to 2 feet less.* It must be remembered that these vessels were heavily rigged; and that their stiffness was, in many cases, largely due to the presence of considerable weights of ballast and water in their holds. From one-seventh to one-eighth of the displacement was frequently assigned to water and ballast; and in some cases a larger proportionate weight was thus carried.

At the present time the most important classes of sailing ships are those belonging to our mercantile marine and those grouped as yachts. Considerable attention has been devoted recently to the exact determination of the stability of both these classes; and in the following table some of the principal results are stated succinctly. A few facts as to various obsolete types of war-ships, are also stated. For the merchant ships the light condition only is represented as was done previously for merchant steamers, and for similar reasons. For the yachts the load condition appears; as there is so little weight carried in them the light condition needs no consideration.† For the war-ships the

* See the "Papers on Naval Architecture" (1827-33); and the "Reports" of Messrs. Read, Chatfield and Creuze (1842-46).

† For the facts respecting the stability of yachts, the author is almost entirely indebted to the valuable investigations of Mr. Dixon Kemp (*Transactions of the Institution of Naval Architects for 1880*). The particulars for

the *Sunbeam* are published with the permission of Sir Thomas Brassey. For those relating to merchant ships his thanks are due to Mr. John Inglis, junior, and Mr. Henry Laird. Much valuable information on the latter subject has also been obtained from the excellent "Reports on Masting" made to the Committee of Lloyd's Register in 1877.

load and light conditions are both stated; in the light condition all consumable stores and water are supposed to be removed from the ships, but all spars, &c., are in place.

No accurate experiments appear to have been made to determine the metacentric heights of laden sailing merchantmen. It is stated, however, on good authority that with ordinary stowage these vessels may obtain metacentric heights of 3 to $3\frac{1}{2}$ feet. On the other hand, it must be noted that the dead weight carried by such vessels frequently exceeds their weight (fully equipped) by 60 to 90 per cent.; so that differences in stowage may produce very considerable variations in stiffness. As a rule, a sailing ship laden with a homogeneous cargo only would not possess a metacentric height exceeding a foot or eighteen inches; and would require to carry either ballast, or dead weight serving as ballast, low down in the hold in order to obtain sufficient stiffness. There are, however, exceptions to this rule, in which metacentric heights of 2 to 3 feet can be secured with a homogeneous cargo, and without ballast; in order to increase the stiffness even in such vessels some dead weight or ballast would usually be carried, although less in proportion than in ships of ordinary form. The opposite extreme to a homogeneous cargo is, of course, that where the cargo consists of heavy materials, such as pig-iron, rails, &c.; and if care is not exercised in stowing such cargoes excessive stiffness may be obtained, causing heavy rolling at sea. The comparatively large metacentric heights of the obsolete classes of sailing war-ships doubtless tended to increase their rolling; but, as these vessels had to fight under sail, a considerable degree of stiffness was essential, in order to prevent excessive heeling and consequent inefficiency of the guns fought on the leeward broadside (see Chapter XII.). In the yachts it will be observed that metacentric heights of from 3 to 4 feet are the rule; there are, however, some classes of broad, shallow yachts in which greater metacentric heights occur, rising in some extreme cases to 8 or 10 feet.

In the foregoing remarks on the "metacentric heights" of various classes of ships, attention has been confined to the relative position of two points, namely, the metacentre and the centre of gravity. It now becomes necessary to remark that the actual vertical positions of these points are governed by entirely different considerations. For example, the vertical position of the centre of gravity depends upon the distribution of the weights of hull, equipment and cargo, or other weights to be carried. This

TABULAR STATEMENT OF THE RESULTS OF INCLINING

Reference Number.	Length between Perpendiculars.	Breadth, extreme.	Depth from Upper Deck at Side amid-ships. (See note.) (D)	Mean Draught.	Displacement.	Meta-centric Height.	Height of Centre of Gravity. (See note) (<i>h</i>)	Ratio, <i>h</i> : D.
War Ships:—								
	Feet.	Feet.	Feet.	Feet ins.	Tons.	Feet.	Feet.	
1	113	35·4	19·2	15·4	670	4·85	15·4	·8
2	100	30·9	15·4	13·8	495	4·77	12·2	·79
3	100	32·3	17·7	13·9	475	5·65	12·5	·7
	12·9	405	4·23	13·5	·76
4	141	38·8	27·5	16·7	1075	4·5	18·	·65
	15·0	875	2·5	19·9	·72
5	131	40·6	27·5	17·4	1055	6·2	17·6	·64
	16·0	890	4·3	19·3	·7
Merchant Ships (light condition):—								
6	273	43·1	25·4	9·7	1440	2·7	20·1	·79
7	263	38·3	24·6	9·2	1100	·75	19·5	·79
8	225	37·5	24·6	9·3	1010	- 1·5	21·	·85
9	217	35·5	22·7	8·7	800	0	18·8	·83
10	215	35·	22·3	9·0	810	- 5	18·4	·825
11	148	26·9	15·	6·5	290	2·0	12·2	·81
Yachts:—								
12	86	18·7	14·2	10·9	160	3·5	7·5	·528
13	100	16·7	13·2	9·4	158	3·3	5·7	·43
14	90·5	18·9	14·4	10·10	155	3·4	8·2	·57
15	85·75	19·3	13·2	10·1	150	3·7	8·4	·64
16	81·25	20·6	12·3	9·5	128	4·0	8·9	·72
17	79·5	17·3	13·7	10·6	115	3·	8·4	·62
18	103	20·8	12·9	9·7	135	4·	8·2	·64
19	154·75	27·5	17·3	13·0	576	3·45	12·4	·72

* For the vessels named in this table, except the yachts, the depth (D) is The height, *h*, of the centre of gravity is also estimated above the top of this draught and the least freeboard; and the height of the centre of gravity is to the mean draught. The lengths and breadths extreme for the yachts are

EXPERIMENTS, ETC., MADE ON VARIOUS CLASSES OF SAILING SHIPS.*

Reference Number.	REMARKS.
1	18-gun corvette of 1832; load condition.
2	18-gun sloop of 1830; load condition.
3	Brig; load condition.
	Brig; light condition.
4	Frigate; load condition.
	Frigate; light condition.
5	Frigate; load condition.
	Frigate; light condition.
6	Full ship-rig; estimate by Lloyds' surveyors; registered length and breadth.
7	Ditto ditto ditto.
8	Poop, fore-castle, and exceptionally heavy rig; result of inclining experiment.
9	Poop, fore-castle, and full ship-rig; ditto.
10	Fore-castle, deck-house, and full ship-rig; ditto.
11	{ Three-masted schooner; estimate by Lloyds' surveyors; registered length and breadth.
12	<i>Miranda</i> , schooner; 78 tons of ballast
13	<i>Jullanar</i> , yawl; 79 5 " "
14	<i>Seabelle</i> , schooner; 73 " "
15	<i>Florinda</i> , yawl; 54 " "
16	<i>Rose of Devon</i> , yawl; 57 " "
17	<i>Kriemhilda</i> , cutter; 54 " "
18	Revenue cutter; 48 " "
19	{ <i>Sunbeam</i> , three-masted schooner; 75 tons of ballast; Sir Thomas Brassey's yacht, with good steam-power.

The stability of these vessels has been fully investigated by Mr. Dixon Kemp.

reckoned to the top of the projection of keel, false-keel, &c., beyond the garb-boards projection. For the yachts, the *total depth* is taken; i.e. the sum of the mean measured from a line drawn parallel to the load-line, at a distance below it equal taken at the load-line.

distribution is usually one of the given conditions of a war-ship design, over which the naval architect has little control. In merchant ships, as has been shown, the designer has even less control over the vertical position of the centre of gravity for the fully laden condition. But, while this is true, it is equally true that the designer has considerable control over the vertical position of the metacentre. That position depends only on the form of a ship, especially near the load-line, and the extent to which she is immersed; and by means of changes in the form of the immersed part of a ship, in the shape of the water-line section, in the proportions of breadth to length, or breadth to draught of water, the designer can obtain very various positions of the metacentre in association with a constant total weight or displacement. In making such variations in form he has, of course, to regard not merely the stability of the ship, but also the resistance she will encounter in passing through the water.

It has been explained that the metacentre affords a ready means of determining the line of action of the buoyancy for a moderate inclination of a ship of ordinary form, and of avoiding the necessity for determining the place of the corresponding centre of buoyancy. But in practice the position of the metacentre is fixed with reference to the centre of buoyancy, corresponding to the upright position of the ship. The distance (B_1M , Fig. 30) is given by the formula,*

$$B_1M = \frac{\text{Moment of inertia of water-line area}}{\text{Volume of displacement}}$$

For transverse inclinations, such as we are now considering, the moment of inertia would be calculated about the middle line of the water-line section; and this may be expressed in terms of the length (L) and breadth extreme (B) of that section. It may in fact be written,

$$\text{Moment of inertia} = K \times L \times B^3,$$

where K is a quantity ascertained by calculation for the particular ship. Since the *cube* of the breadth appears in the expression for the moment of inertia, and only the first power of the length, any increase in the breadth must be most influential

* The "moment of inertia" of an area about any axis may be defined as the sum of products of each element of that area, by the square of its distance

from the axis. The proof of the formula given above involves mathematical treatment which would be out of place here.

in adding to the value of the height (B_1M) of the metacentre above the centre of buoyancy.

The drawings of a ship furnish the naval architect with *data* for exact calculations of the volume of displacement, the position of the centre of buoyancy, and the moment of inertia of the water-line area, corresponding to any assigned draught of water. Details of the method of calculation would be out of place here; but it may be of interest to state certain approximate rules derived from such calculations, by means of which rough estimates may be made of the vertical positions of the centre of buoyancy and transverse metacentre in ships of ordinary form.

I. For the approximate depth of the centre of buoyancy below the water-line from *two-fifths* to *nine-twentieths* of the mean draught may be taken. The larger coefficient should be used for ships of full form. If the draught is increased by an unusually deep keel or false keel the centre of buoyancy will lie higher than in ships of ordinary form. In yachts, for example, it is sometimes distant from the water-line only twenty-seven to thirty per cent. of the mean draught.

II. For the coefficient K in the formula for the moment of inertia of the water-line area, or plane of flotation, the following approximate values may be taken :

	K
Ships with extremely fine forms of load water-line	} .04
Ships with moderately fine forms of ditto	} .05 to .055
Ships of full forms of ditto06 to .065
A rectangle083

In applying these coefficients it must be noted that the length and beam, in the formula for the height of the metacentre above the centre of buoyancy, are to be measured at the load-line; so that these dimensions may differ from the extreme length and breadth.

As an example, take her Majesty's ship *Iron Duke*, for which length (L) is 280 feet, breadth extreme (B) 54 feet, mean draught 22 feet, displacement 6000 tons. Here K should about equal $\frac{11}{200}$. Hence

$$\left. \begin{array}{l} \text{Moment of inertia of water-} \\ \text{line area} \end{array} \right\} = \frac{11}{200} \times 280 \times (54)^3.$$

$$\text{Volume of displacement} = 6000 \times 35.$$

$$\left. \begin{array}{l} \text{Height of metacentre above} \\ \text{centre of buoyancy (B}_1\text{M)} \end{array} \right\} = \frac{11 \times 280 \times (54)^3}{200 \times 6000 \times 35} = 11.5 \text{ feet.}$$

$$\left. \begin{array}{l} \text{Also (by Rule I.) approxi-} \\ \text{mate depth of centre of} \\ \text{buoyancy below water} \\ \text{surface} \end{array} \right\} = \frac{2}{3} \times 22 \text{ feet} = 8.8 \text{ feet.}$$

Hence the metacentre should be situated about 2.7 feet above the water surface. Exact calculation showed it to be about 2.4 feet above the water surface.

A still more rapid method of approximating to the height of the metacentre above the centre of buoyancy is based upon a combination of the preceding formula, with the rules for "coefficients of fineness" given on page 3. Calling these coefficients C , and using the same notation as before, we have

$$B_1M = \frac{K \times L \times B^3}{C \times L \times B \times D};$$

neglecting any small difference there may be between the length between perpendiculars and breadth-extreme of the ship and her greatest dimensions at the load-line. Reducing this expression, it appears that

$$B_1M = \frac{K}{C} \cdot \frac{B^2}{D} = \alpha \cdot \frac{B^2}{D},$$

which is an expression of the simplest character, and shows how influential upon the height B_1M is the ratio of breadth to mean draught. The following are average values of the coefficient α , determined from a considerable number of examples:—

	Values of α .
Ships of ordinary forms09 to .1
Ships of full forms08 to .09

The coefficient .1 applies very fairly to nearly all classes of unarmoured war-ships in the Royal Navy and to some merchant ships; the coefficient .09 applies fairly to the majority of armoured ships and to many classes of merchant ships. For vessels of exceptionally fine form or very deep keels, like yachts, the coefficient rises to .15; and for vessels of very full form, the coefficient falls to .08. From these statements it will be evident that, while approximate rules may be useful in making rough estimates, they cannot take the place of exact calculations, by which the naval architect determines the actual positions of the

metacentre and centre of buoyancy, corresponding to any assigned draught of water in a ship of known form.

By means of a series of such calculations, it is possible to construct a diagram—termed the “metacentric diagram”—showing the vertical positions of the metacentre and the centre of buoyancy for any mean draught of water between the deep load-line at which the vessel floats when fully laden, and the light-line at which she floats when empty. Such diagrams are very useful, especially for merchant ships subjected to great variations of draught. The construction is very simple. Any horizontal line W_1L_1 (Fig. 30a) is taken to represent the load-line of the ship. Through any point W_1 on it a vertical line B_1M_1 is drawn: the depth of the centre of buoyancy corresponding to the load-line is then set down below W_1L_1 on a certain scale, and this fixes the point B_1 . The length B_1M_1 represents, on the same scale, the corresponding height of the metacentre M_1 , above the centre of buoyancy B . Through W_1 the straight line $W_1W_2W_3$ is also drawn, making an angle of 45 degrees with W_1L_1 . Then, for some other water-line parallel to the load-line (say W_2L_2 , Fig. 30a), a corresponding construction is performed. The known distance between the two water-lines is set down from W_1L_1 , and W_2L_2 is drawn parallel to W_1L_1 ; through the point W_2 , where W_2L_2 cuts the line $W_1W_2W_3$, a new vertical B_2M_2 is drawn. On this vertical are set off, to scale, the calculated depth of the centre of buoyancy (B_2) below the line W_2L_2 , and the height (B_2M_2) of the corresponding metacentre above the centre of buoyancy. A similar process is applied to several other parallel water-lines at still lighter draughts: and so finally a series of points $B_1B_2B_3$ —are determined, through which a curve is drawn, showing the *locus of the centre of buoyancy* for variations in mean draught from the extreme load condition to the extreme light condition. In a similar manner a curve $M_1M_2M_3$ —is drawn, giving the corresponding *locus of the metacentres*. Having obtained these curves, it is possible by means of simple measurement to determine the vertical positions of the centre of buoyancy and metacentre corresponding to any water-line parallel to the load-line W_1L_1 and intermediate between it and the light-line. For example, let WL (Fig. 30a) represent such a line

FIG 30 a

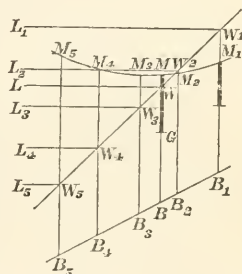

at a given distance below W_1L_1 . Where WL cuts $W_1W_2W_3$ draw the vertical BWM ; the intersection of this vertical with the metacentric curve gives the position M of the metacentre corresponding to WL ; and its intersection with the curve of centres of buoyancy fixes the position B of the centre of buoyancy. The metacentric locus is the more important, and the other curve is chiefly valuable as the means of constructing that locus. It should be remarked that the metacentric locus only applies accurately to water-lines drawn parallel to W_1L_1 . If, as commonly happens, a ship changes trim considerably as she lightens, then the vertical positions of both centre of buoyancy and metacentre corresponding to the lighter line may not be accurately represented by the points fixed on the metacentric diagram by means of the *mean draught*, obtained by taking half the sum of the draughts forward and aft.

From the preceding explanations, it will be obvious that in different classes of ships the forms of metacentric curves (such as $M_1M_2M_3$, Fig. 30a) may vary considerably. The only safe course in practice is, therefore, to construct the metacentric diagram for each class. But it may be interesting to give a few typical illustrations of such curves.* Fig. 30c shows a very common case for war-ships of ordinary form; the metacentric curve gradually rises from the load towards the light draught. On the same diagram are indicated a convenient arrangement for the most important *data*—displacement, and tons per inch—at each draught. Another form occurring less frequently in war-ships makes the metacentric curve almost horizontal between the extreme draughts. In vessels with “peg-top” forms of cross-sections—such as the Symondite type of the Royal Navy—the metacentre occupies its highest position in the ship when she is at the load-draught, and falls gradually as the draught lightens; see Fig. 30b. Another variety of metacentric locus appears in Fig. 30a, where the metacentre first falls as the draught lightens, then passes through a position of minimum

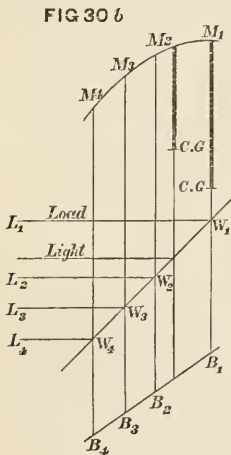

* For further details on this subject see a paper by the author on “The Geometry of Metacentric Diagrams;”

Transactions of the Institution of Naval Architects for 1878.

height, and gradually rises again. This frequently occurs in merchant ships of deep draught (in proportion to their beam) when fully laden, and with approximately vertical sides in the region between the load and light lines. The highest position of the metacentre in these ships usually corresponds to the light-line; and the lowest to a draught intermediate between the load and light lines: very frequently the heights at the load and light lines are nearly equal, and (as indicated on Fig. 30a) the metacentric locus lies wholly below the load-line. In war-ships, on the contrary, that locus usually lies wholly above the load-line, the ratio of breadth to load-draught being greater than the corresponding ratio for merchant ships. The range of draught from the load to the light condition is much less for war-ships than for merchant ships.

FIG 30 c

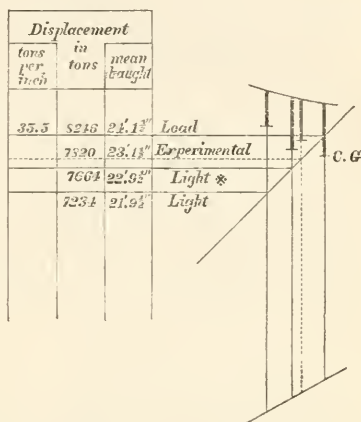

Note.—This diagram represents the variations in metacentric height of H.M.S. *Monarch*. In the Light* condition 430 tons of water-ballast are supposed to be placed in the double-bottom.

Metacentric diagrams are chiefly useful as a means of rapidly determining the stiffness of a ship when floating at a certain water-line, and with the centre of gravity in a certain position, which is fixed by an independent investigation. For a certain mean draught and trim, the metacentre remains at a constant height in the ship; and variations in the stowage of a given amount of dead weight can only affect the stiffness by the changes they produce in the vertical position of the centre of gravity. When that position has been ascertained for any given condition of stowage, it is usually shown on the metacentric diagram. For instance, in Fig. 30a, when the ship floats at WL with M as the metacentre, suppose the point G to represent the ascertained position of the centre of gravity. Then GM represents (to scale) the "metacentric height," which measures the stiffness of the ship, as explained on page 78. For war-ships it is customary to perform this construction for both the load and light conditions, as well as for the condition of the ships when inclined (see page 98), for the purpose of ascertaining the vertical position of the centre of gravity. For merchant ships the light condition only can be

dealt with accurately in the same fashion; since the stiffness in the load condition varies with changes in stowage. In many cases, however, the volumes and common centre of gravity of the total volume of the spaces assigned to cargo are estimated; the maximum load-line is fixed; the corresponding dead weight is ascertained, and thence the number of cubic feet of space available for stowing each ton of dead weight is ascertained. A homogeneous cargo of this density is then supposed to be placed on board, with its centre of gravity at the centre of gravity of the cargo-space. The weight of the ship when floating light, as well as the position of her centre of gravity in that condition, can be readily ascertained by an inclining experiment. Hence, combining the assumed cargo with these experimental data, a final result is obtained for the vertical position of the common centre of gravity of the fully-laden ship; and her metacentric height is determined for the assumed

FIG. 30d

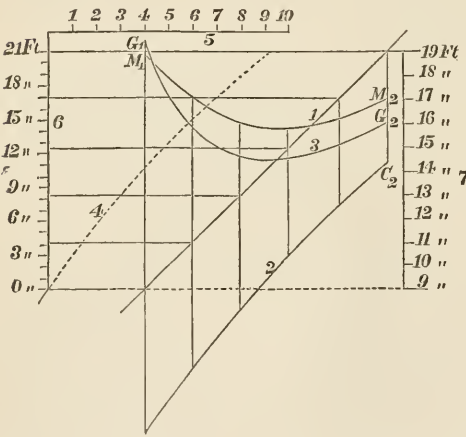

References.—1. Curve of metacentres; 2. Curve of centre of gravity of homogeneous cargo; 3. Curve of centre of gravity of hull and homogeneous cargo; 4. Curve of capacity for space occupied by cargo; 5. Scale of capacity (in units of 1000 cubic feet); 6. Scale for height of cargo above ceiling; 7. Scale of mean draught of water.

conditions of stowage, which are about as little favourable to stiffness as any conditions likely to occur in actual service, and lie outside the range of probability in some classes of ships. An interesting extension of this method is shown on Fig. 30d.*

The metacentric locus is drawn from light to load lines in the usual manner. In the light condition M_1 is the metacentre, and G_1 the centre of gravity of the ship lies above it, so that the vessel is in unstable equilibrium.

It is found that a homogeneous cargo occupying about 58.5 cubic feet per ton of dead weight would just fill the cargo-spaces and bring the ship to her intended maximum load-line. If fully laden in this manner, the

* The author is indebted for this diagram to his friend Mr. John Inglis, jun.

homogeneous cargo has its centre of gravity at C_2 , the common centre of gravity of ship and cargo is at G_2 , and the metacentre is at M_2 , about 15 inches above the centre of gravity G_2 . As the ship has taken in cargo, she has therefore acquired stiffness. So far the diagram represents the common practice described above; but it furnishes further information of a valuable character. First, there is a "curve of capacity"

giving the volume of the cargo-space corresponding to various heights of cargo in the hold; second, there is a curve giving the locus of the centre of gravity of the cargo-space as the height of the cargo is increased. The curve of capacity resembles in its construction the curve of displacement described on page 6; and the curve of centres of gravity of cargo-spaces resembles the locus of the centres of buoyancy on metacentric diagrams. Having this data graphically recorded, another step may be taken. Suppose the ship to be taking in cargo of the assumed average specific gravity; and while her lading is incomplete to be floating at a given water-line intermediate between the load and light lines. Her displacement at this given line is known; thence the dead weight on board her is easily estimated, also the volume it occupies; the height of its surface and that of its centre of gravity can then be read off on the appropriate curves of capacity and centres of gravity of homogenous cargo. Finally, the common centre of gravity of hull and homogenous cargo can be found for the given water-line. A curve passed through the points G_1 G_2 , &c., gives the locus of this common centre of gravity of hull and cargo throughout the period of loading; and the relation of this curve to the metacentric curve shows how the stiffness varies, under the assumed conditions, as the loading goes on.

Such a graphic record as that in Fig. 30*d* can scarcely fail to

FIG 30*e*

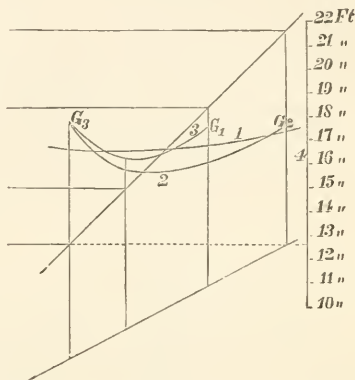

References.— G_3 . Centre of gravity of ship without cargo; G_2 . Centre of gravity of ship and cargo, supposing the latter to be homogeneous, to fill the holds, and to weigh 2250 tons; G_1 . Centre of gravity of ship and cargo, the dead weight being 1430 tons and other conditions as before; 1. Curve of metacentres; 2. Curve of centre of gravity of ship and cargo as the 2250 tons are discharged; 3. curve of centre of gravity of ship and cargo as the 1430 tons are discharged; 4. Scale for mean draughts of water.

be of value; although it does not strictly correspond to the conditions of ordinary service, it enables any other conditions to be readily estimated for. The greatest interest, of course, attaches to the two extreme draughts; and of these the fully-laden condition is the more important, as previously indicated.

Fig. 30e contains another example of this method applied to a cargo-steamer; but in this case the curves of capacity and heights of centres of gravity of cargo are omitted. The reference letters agree with those on Fig. 30d; and it will be observed that under the assumed conditions of stowage the vessel is in unstable equilibrium both when light and when fully laden, whereas for a considerable range of draught between these extremes she possesses a positive metacentric height, reaching a maximum value of 1 foot about midway between load and light draught. This

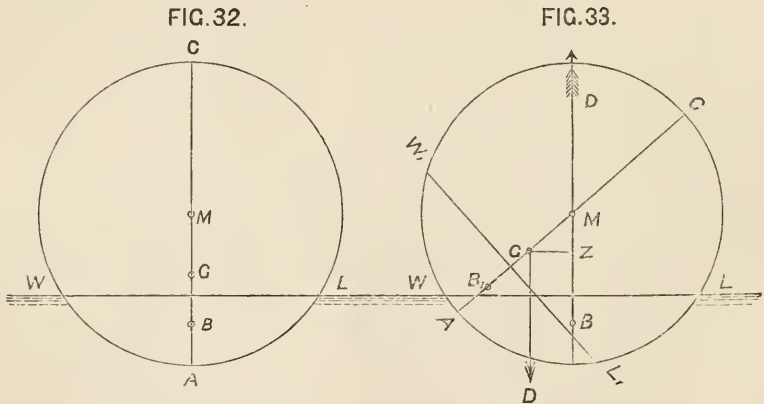

vessel represents a class which is successfully employed in certain trades, with the frequent use of water-ballast when homogenous cargoes are carried.

Summing up the foregoing remarks on the metacentric method of estimating stability, it may again be stated that the metacentre is simply a fixed point through which the buoyancy of a ship may be supposed to act for all angles of inclination up to 10 degrees or 15 degrees in vessels of ordinary form. This is tantamount to saying that the metacentre may be taken as a hypothetical point of suspension for a ship in order to estimate the righting moment when she is steadily heeled to any angle within the limits named, as indicated on Fig. 30, page 76.

For vessels of unusual form—as, for example, the monitor type with extremely low freeboard—the metacentric method cannot be

trusted for such considerable inclination as in ordinary types. On the other hand, there are certain forms for which the meta-centric method applies to even greater inclinations, or even for all possible inclinations. The well-known cigar-ships exemplify the last-named condition. All transverse sections of these ships are circles. Suppose Fig. 32 to represent the section containing the centre of buoyancy B for the upright position, WL being the water-line. Then obviously for any inclined position (such as is shown in Fig. 33, where the original water-line is marked W_1L_1 , and the original centre of buoyancy B_1) the new centre of buoyancy B determines the vertical line of action (BM) of the buoyancy, which intersects the original vertical (B_1M) in the centre (M) of the cross-section. Hence, if G be the centre of gravity, we shall have for any angle of inclination α ,

$$\text{Moment of statical stability} = D \times GM \sin \alpha.$$

In other words, the cigar-ship may be regarded as a pendulum turning about the point of suspension M throughout the whole range of its transverse inclinations, instead of limiting that comparison to 15 degrees, as is done for ordinary ships.

The conditions of stability of a wholly submerged or submarine vessel are as simple as those of the cigar-ship. In Fig. 34 a cross-section of such a vessel is given; B is the centre of buoyancy, and for a position of equilibrium B and the centre of gravity G must lie in the same vertical line. When this condition is unfulfilled (as in the diagram), the weight and the buoyancy form a mechanical couple, just as in the case of a ship having

FIG. 34

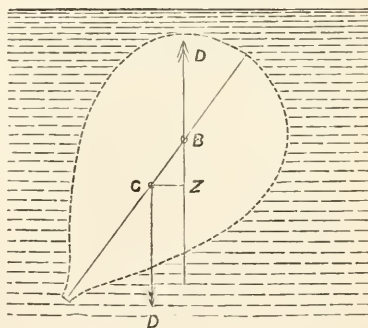

a part of her volume above water. For the submarine vessel, however, inclination produces no change in either the form of the displacement or the position of the centre of buoyancy; for all positions the buoyancy acts upwards through the same point B , and the total weight downwards through the centre of gravity G . Consequently stable equilibrium is only possible when the centre of gravity lies (as in the diagram) below the centre of buoyancy; for obviously, if G were placed vertically above B , and the vessel were inclined ever so little, no position of rest could be

reached until G was placed vertically below B. For wholly submerged floating vessels, therefore, the centre of buoyancy takes the place of the metacentre in vessels partially immersed, and for all angles of inclination (such as a),

$$\text{Moment of statical stability} = D \times GB \sin a.$$

Attention will next be directed to some of the more important practical applications of the metacentric method of estimating stability. The first to be noticed will be the *inclining experiment*, by means of which the vertical position of the centre of gravity of a ship is ascertained after her completion. In designing a new ship the naval architect makes an estimate for the position of the centre of gravity; and with care can secure a close approximation to accuracy. On the other hand, a lengthy and laborious calculation is required in order to fix the position of the centre of gravity accurately; and it is now generally agreed that for purposes of verifying estimates, as well as of obtaining trustworthy data for future designs, inclining experiments are desirable. These experiments are simple as well as valuable, and it may be of service to indicate the manner in which they are usually conducted in ships of the Royal Navy.

The ship being practically complete—with spars on end, the bilges dry, the boilers either empty or quite full, no water in the interior free to shift, and all weights on board well secured so that they may not fetch away when she is inclined—is allowed to come to rest in still water. A calm day is desirable, but if there be any wind, the ship should be placed head or stern to it and allowed to swing free, the warps being so led that they may practically have no effect in resisting the inclination of the ship. For the purpose of producing inclination, piles of ballast are usually placed on the deck (see W, W, Fig. 35), being at first equally distributed on either side, but in some cases the guns of a ship have been traversed from side to side instead of using ballast. Two or three long plumb-lines are hung in the hatchways, and by means of these lines the inclinations from the upright are noted. All being ready, and the ship at rest, the positions of the plumb-lines are marked, and the draught of water is taken. The position of the metacentre corresponding to this draught can then be ascertained by calculation from the drawings. Next a known weight of ballast (W, Fig. 35) is moved across the deck through a known distance. The vessel

becomes inclined, and after a short time rests almost steadily in this new position; in other words, is once more in *equilibrium*, as shown in Fig. 36. Consequently, for this new position, the meta-centre *M* must be vertically above the new centre of gravity (*G*₁); for obviously the shift of ballast has moved the centre of gravity of the whole ship through a certain distance *GG*₁ parallel to the

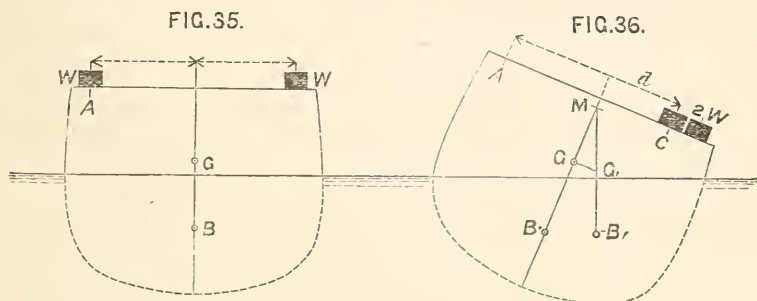

deck, and it is this movement of the centre of gravity that produces the inclination. Suppose *a* to be the angle of inclination noted on the plumb-lines when the ballast *W* has been moved through the transverse distance *d*. Then (since *GG*₁ is perpendicular to *GM*) we have,

$$GG_1 = GM \tan a; \text{ or } GM = GG_1 \cot a.$$

And if *GG*₁ can be determined, the distance of the centre of gravity below the known position of the metacentre can be found, and the true vertical position of the centre of gravity is ascertained for the experimental condition of the ship. Any subsequent corrections consequent on the removal of the ballast, addition of water in the boilers, or other alterations in the condition of the ship when fully equipped, can be easily made.

The value of *GG*₁ can be readily estimated by means of a simple calculation, the character of which may be better seen by means of an illustration. A uniform lever (Fig. 37) is loaded with two weights, *W*, placed at equal distances from the middle: it will then balance upon a support placed at the middle (*G*) of the length. Now let one of the

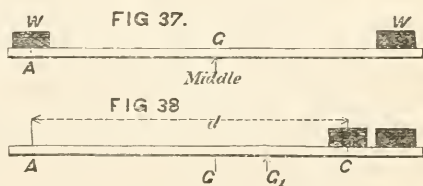

weights W be moved to the opposite end (as in Fig. 38) through a distance d . Obviously the point about which the lever will balance (that is, the *centre of gravity* of the lever and the weights W) will no longer be at the middle, but at some point (G_1 , Fig. 38) to the right of the middle. If D be the total weight of the lever and the weights it carries, by the simplest mechanical principle it follows that

$$D \times GG_1 = W \cdot d; \text{ whence } GG_1 = \frac{W \cdot d}{D}.$$

What is true in this simple case is true also for the ship; the line GG_1 , in Fig. 36, joining the old and new positions of the centre of gravity, must be parallel to the deck-line, across which the weight W is moved, and the above expression for GG_1 holds. Hence, since

$$GM = GG_1 \cdot \cot a, \text{ while } GG_1 = \frac{W \cdot d}{D},$$

it follows that

$$GM = \frac{W}{D} \cdot d \cot a,$$

an equation fully determining the position of the centre of gravity G in relation to the known vertical position of the metacentre M , ascertained by calculation from the drawings.

As an example, suppose a ship for which the displacement (D) is 4000 tons to have 60 tons of ballast placed upon her deck, 30 tons on each side. When the 30 tons (W) on the port side is moved to starboard through a transverse distance of 40 feet (d), the vessel is observed to rest at a steady heel of 7 degrees from her original position of rest. Then, from the above expression—

$$\begin{aligned} GM &= \frac{W}{D} \cdot d \cot a = \frac{30}{4000} \times 40 \times \cot 7^\circ \\ &= \frac{3}{100} \times 8.144 = 2.43 \text{ feet.} \end{aligned}$$

In practice it is usual to subdivide the ballast on each side into two equal piles, and to make four observations of the inclinations produced by—

- (1) Moving one pile of ballast from port to starboard;
- (2) Moving second pile of ballast from port to starboard.

These two piles having been restored to their original places, the plumb-lines should return to their first positions, unless some

weights other than the ballast have shifted during the inclinations. Then two other inclinations are produced and noted by—

- (3) Moving one pile of ballast from starboard to port ;
- (4) Moving second pile of ballast from starboard to port.

The results of observations (1) and (3), (2) and (4) should agree respectively, if the four piles of ballast are of equal weight, and if the distance d is the same for all ; the inclinations in (2) and (4) should be about twice those in (1) and (3). The values of GM are deduced from each experiment, and the *mean* of the values is taken as the true value of the metacentric height at the time of the experiment. Thence it is easy to deduce the metacentric height for the vessel in her fully equipped sea-going condition, or in any other assigned condition.

The reason for great caution in preventing any motion of weights on board, other than the ballast, during the inclining experiment, will appear from the expression given above for the motion (GG_1) of the centre of gravity. The moment due to the motion of the ballast Wd is comparatively small ; in the above example, which is a fair one,

$$Wd = 30 \text{ tons} \times 40 \text{ feet} = 1200 \text{ foot-tons,}$$

and

$$GG_1 = \frac{1200}{4000} = \frac{3}{10} \text{ foot only.}$$

Now, if other weights, and particularly free water in the bilges shift as the ship inclines, their aggregate moments may bear a considerable proportion to $W \cdot d$, and so the estimated value of GG_1 may be less than the true one, if no account is taken of the shift of water. For example, 5 tons of water free to shift 30 feet in a transverse direction would have a moment (5×30) of 150 foot-tons, or no less than *one-eighth* that of the ballast, and if its effect were unobserved through carelessness, the motion of the ballast would be credited with producing an inclination about *one-eighth greater* than it could produce if acting alone. In the foregoing example, if such an error had been made, instead of writing $Wd = 1200$ foot-tons, it should have been $1200 + 150 = 1350$ foot-tons ; so that the metacentric height would have been—

$$GM = \frac{1350}{4000} \times \cot 7^\circ = \frac{27}{80} \times 8.14 = 2.75 \text{ feet.}$$

In performing inclining experiments, too great care cannot, therefore, be taken to ensure that no other weights shall shift than those made use of to produce the inclinations.

A second useful application of the metacentric method is found in a practical rule for estimating the angle of heel produced by moving a weight athwartships in a ship. Referring to the formula

$$GM = \frac{W}{D} d \cot \alpha,$$

we may arrange it as follows,

$$\tan \alpha = \frac{W \cdot d}{D \cdot GM},$$

and for the case under consideration assume that all the quantities on the right-hand side of the equation are known, the value of $\tan \alpha$ being thus determined. As an example, suppose a weight (W) of 5 tons to be moved horizontally a distance (d) of 30 feet athwartships in a ship of 1500 tons displacement (D), having a metacentric height of 3 feet; then,

$$\begin{aligned} \tan \alpha &= \frac{5}{1500} \times \frac{30}{3} = \frac{1}{30} \\ \alpha &= 2^\circ \text{ (nearly).} \end{aligned}$$

This rule is of service in approximating to the heel produced by transporting guns or heavy weights from side to side on a deck or platform which is nearly horizontal athwartships.

When the vertical positions of weights already on board a ship are changed, the result is simply a change in the position of the centre of gravity of the ship; for obviously the displacement and position of the metacentre remain unaltered, since there is no addition or removal of weights. The shift of the centre of gravity can be readily estimated by the rule already given. Suppose the total weight moved to be w , and the distance through which it has been raised or lowered to be h , then, if GG_1 be the rise or fall in the centre of gravity,

$$GG_1 = \frac{w \cdot h}{D},$$

where D is the total displacement of the ship. If GM was the original height of the metacentre above the centre of gravity, for an angle α within the limits to which the metacentric method applies,

Original moment of statical stability = $D \times GM \times \sin \alpha$

Altered moment of statical stability = $D (GM \pm GG_1) \sin \alpha.$

The alteration is an increase when the weights are lowered; a decrease when the weights are raised. As an example, take the case of a ship of 6000 tons displacement, having a metacentric

height of $3\frac{1}{4}$ feet; and suppose spars, &c., weighing together 10 tons, to be lowered 70 feet. Then

$$GG_1 \text{ (fall of centre of gravity)} = \frac{10 \times 70}{6000} = \frac{7}{60} \text{ foot.}$$

$$\left. \begin{array}{l} \text{Original moment of statical} \\ \text{stability} \end{array} \right\} = 19,500 \text{ foot-tons} \times \sin a.$$

$$\left. \begin{array}{l} \text{Altered moment of statical} \\ \text{stability} \end{array} \right\} = 6000 \left(3\frac{1}{4} + \frac{7}{60} \right) \sin a.$$

$$= 20,200 \text{ foot-tons} \times \sin a.$$

Another case where weights already on board a ship are shifted, involves a motion of the centre of gravity of the weights moved in both the horizontal and the vertical directions. For example, when coal or grain cargoes are carried, and a vessel

FIG 30f

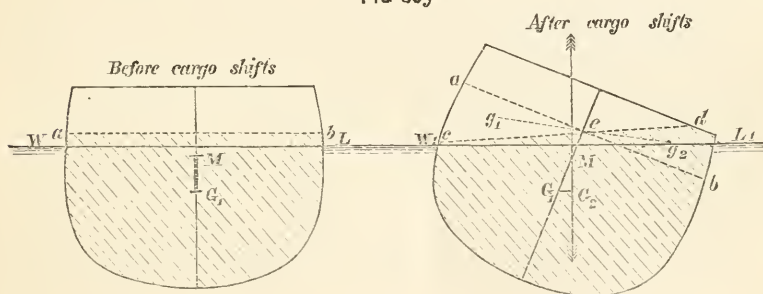

is steadily heeled under sail to one side for a considerable period, the cargo may shift to leeward. In such cases, if the inclining forces were removed, the ship would obviously not return to the upright, but would rest in an inclined position, which can be very simply determined. Let Fig. 30f illustrate this case. WL is the load-line; M is the metacentre corresponding thereto. Suppose, when the ship is upright in still water, the grain in the hold has *ab* for its surface; and that after she has been steadily heeled for a considerable time that surface changes to *cd*. Let *ab* and *cd* intersect in *e*. Then, what has happened is this: a wedge-shaped mass of grain originally at *acc*, of a known weight *W*, and having its centre of gravity at *g₁*, has been shifted into the position *bed* with its centre of gravity at *g₂*. Join *g₁g₂*. Then, as explained above, if *G₁* be the centre of gravity of the ship and cargo before any shift took place, its new position

G_2 will be found on a line G_1G_2 drawn parallel to g_1g_2 ; and we must have

$$G_1G_2 = \frac{W}{D} \cdot g_1g_2.$$

Now, if the inclining forces are supposed to be removed, the ship will find her position of equilibrium, when the new position G_2 of the centre of gravity lies vertically below the metacentre M . And since two sides of the triangle G_1MG_2 (G_1M and G_1G_2) are given, as well as the angle MG_1G_2 , that triangle is fully known, and the angle G_1MG_2 can be ascertained. This will be the angle of heel required.

As an example take the case of a ship of 3200 tons displacement, which when fully laden with a cargo of coals has a metacentric height of $2\frac{1}{2}$ feet. Suppose 80 tons to be shifted so that its centre of gravity moves 20 feet transversely, and 4 feet vertically. Then the corresponding transfers of the centre of gravity of ship and cargo will be given by the equations.

$$\text{Horizontal motion} = \frac{80 \times 20}{3200} = \cdot 5 \text{ foot.}$$

$$\text{Vertical rise} = \frac{80 \times 4}{3200} = \cdot 1 \text{ ,,}$$

The angle of heel in this case would be given with quite sufficient accuracy by the equation

$$\tan a = \frac{\text{Horizontal transfer of centre of gravity}}{\text{Original metacentric height}} = \frac{\cdot 5}{2 \cdot 5} \frac{1}{5},$$

$$\text{or } a = 11\frac{1}{3}^\circ \text{ (nearly).}$$

If the vertical rise in the centre of gravity had been greater, the more accurate method of determining the heel would have been applied. It need hardly be added that, in practice, all possible precautions should be taken to prevent such shifts of cargo, and that particular care is needed in grain-laden ships.

The preceding illustration also serves to indicate how the statical stability of a ship is affected by the presence of free water in her hold. If the skin of the ship is intact, the water in the hold may be treated as a load carried in her bilges, and its motion towards the side to which the ship may be steadily heeled will be equivalent to a shift of the centre of gravity in that direction, and to a consequent change in the stability, resembling that produced by a shifting cargo. Damage to the bottom of a ship may be so serious as to admit large quantities of water into the hold, and to leave them in *free communication* with the

water outside. This condition of things as a possible cause of foundering has already been discussed at length; * it is therefore only necessary to refer to the effect upon the statical stability of a ship having a bilged compartment. Except in the few cases where watertight decks or platforms form tops to compartments, it may be said that the bilged compartment ceases to contribute any buoyant water-line area. In fact, taking the box-shaped vessel in Fig. 11 (page 16) as an example, the effect of filling the compartment is to reduce the original water-line area by the area (fg) of the top of the compartment. Now it has been explained above that the vertical position of the metacentre in relation to the centre of buoyancy depends upon the form and area of the buoyant water-line, or plane of flotation; any decrease therefore in area and moment of inertia must be accompanied by a consequent decrease in the height of the metacentre above the centre of buoyancy. But, on the other hand, the deeper immersion of the ship, when the compartment is bilged, leads to a rise in the position of the centre of buoyancy in the ship. The difference between this fall of the metacentre and rise of the centre of buoyancy measures the alteration in the metacentric height; and, for angles of heel up to 10 or 15 degrees in ships of ordinary form, will give a fair measure of the change of stiffness produced by filling the compartment. In some cases (and almost invariably where a midship compartment is damaged) the stability is decreased; in others it is increased. Without an investigation it is frequently not easy to determine the true character of the change. The difference between this case and that where water in the hold is not in free communication with the water outside lies principally in the fact that with a damaged bottom, if there be no horizontal watertight partition above the level of the hole, the water in the bilged compartment always maintains the same level as that of the water outside when the ship is held steadily in any position. Having, therefore, determined by this condition how much water will enter the damaged compartment, if we then conceive the bottom to be made good, and the compartment to contain that quantity of water, the statical stability of the ship may be estimated at any angle of inclination to which the metacentric method applies in the same manner as was explained above for a vessel having free water in the hold and the bottom intact.

The condition of a central-citadel ironclad, when her unarmoured ends above the shot-proof deck have been "riddled" by shot and

* See Chapter I. pages 15-24.

shell, furnishes an illustration of the foregoing remarks. In the *Inflexible*, for example, the central armoured citadel is 110 feet long; before and abaft it the protection of the ship is secured by a strongly-plated deck, about $6\frac{1}{2}$ feet under water; and the spaces above this deck are minutely subdivided into watertight compartments, many of which are occupied by cork-packing, &c. Suppose the ship, with her sides intact, to float at the mean draught of 24 feet 7 inches, then her centre of buoyancy is about $13\frac{1}{2}$ feet above the keel-plates, and her transverse metacentre $17\frac{1}{2}$ feet above the centre of buoyancy. Supposing the unarmoured ends above the plated deck to be completely riddled, every space being thrown open to the sea, but the cork-packing to remain in place, the ship would sink about 2 feet deeper in the water, her centre of buoyancy would rise about 3 inches, and the metacentre would only be 11 feet above the centre of buoyancy. In other words, this serious damage to the ends would decrease the moment of inertia of the buoyant water-line area about 37 per cent. from its value in the intact condition. This fall in the metacentre reduces its height above the centre of gravity from $8\frac{1}{4}$ feet in the intact condition to 2 feet in the riddled condition.

When other than statical conditions come into operation, as, for instance, when a ship is rolling rapidly in a seaway, it is important to distinguish between the cases of free water contained within an undamaged skin and of water admitted to the interior by fracture of the bottom. And, further, it is necessary to distinguish between the cases of serious and slight damage to the bottom when dealing with the ship in motion, whereas no such distinction is necessary in discussing the stability for a steady heel. When held at a steady heel, free water in the hold will adjust its surface horizontally, even if there be some obstruction to the motion of the water towards this position of rest; but if the ship is in motion and changing her position rapidly, the element of time has to be considered, and the free water contained within an undamaged skin may not move rapidly enough as compared with the motions of the ship to maintain the horizontality of its surface. Similarly, when the ship is held at a steady heel, it does not make any difference whether a hole in the bottom of a bilged compartment is large or small; the final result will be that the compartment will be filled up to the level of the water outside. But the time taken in filling the compartment, or allowing any quantity of water to pass through the hole, of course depends upon the size and situation of the hole in the bottom; and therefore, when a ship is in motion, and

the volume of any compartment up to the level of the water outside may be constantly changing, there is a marked difference between the stability in the cases of slight and serious damage.

It will be only necessary to refer once more to Figs. 15-17 (pages 23 and 24) in order to illustrate the beneficial effect upon the statical stability of horizontal watertight platforms. When the compartment above the flat pq in Fig. 17 is filled, the stiffness of the box-shaped vessel is *less* than before the damage occurred; owing to the loss in buoyant water-line area bringing down the metacentre more than is compensated for by the rise in the centre of buoyancy. When the compartment below the flat pq in Fig. 16 is filled, there is no loss of buoyant water-line area, and consequently no fall in the metacentre relatively to the centre of buoyancy, while the latter point rises, owing to the deeper immersion, the final result being an *increase* in stiffness as compared with the undamaged vessel.

Longitudinal bulkheads, such as are shown in Fig. 14, page 22, are very valuable aids to the maintenance of transverse stability when there is free water in the hold, by limiting the transverse shift of that water as the vessel becomes inclined, as well as by limiting the quantity of water admitted by damage to the bottom. Longitudinal partitions, or "shifting boards," are similarly of great value, especially in grain-laden ships, in preventing shift of cargo.

Double-bottom compartments (such as those described in Figs. 20-25, page 26) are commonly used for water ballast. The spaces

below the watertight longitudinals (a , Figs. 21-25) at the bilges are generally employed for this purpose, arrangements being made for readily filling or emptying these spaces. It is most important that the compartments used for water ballast should be *quite full*; otherwise, some motion, and consequently a

decreased stability, will result as the ship becomes inclined. When so filled, the weight of water ballast in the compartments may be treated as if it were solid ballast, not capable of any shift, in estimating the change in the stability produced by its addition.

A ready rule for estimating the change in the metacentric

FIG 39.

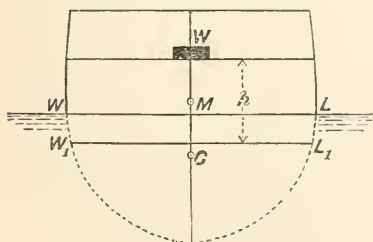

stability or stiffness of a ship produced by adding or removing weights, of which the vertical positions are known, will be useful. Suppose Fig. 39 to represent a case where weights amounting in the aggregate to W tons have been put on board a ship, with their centre of gravity h feet above the water-line (W_1L_1) at which the ship floated before the weights were added. Let G be the original position of the centre of gravity of the vessel, and M the metacentre corresponding to the water-line W_1L_1 ; then, if D be her displacement to that line, her stability for any angle a within the limits to which the metacentric method applies will have been

$$\text{Moment of statical stability} = D \times GM \sin a.$$

The addition of the weights W will increase the immersion of the ship by a certain amount, which can be estimated by the method of "tons per inch" explained in Chapter I. It may be assumed, however, that commonly the weights added are comparatively so small that their addition will only immerse the vessel a few inches; the centre of gravity of those weights may be fixed relatively to the original water-line W_1L_1 .* Their moment about W_1L_1 will be $= W \times h$ foot-tons; and then the expression for the statical stability at the angle a will become altered by the addition of the weights to

$$\text{I. Moment of statical stability} = (D \times GM - W \times h) \sin a.$$

Had the weights W been placed with their centre of gravity at a distance h below W_1L_1 , the stability would have been *increased* by the amount $Wh \sin a$, and

$$\text{II. Moment of statical stability} = (D \times GM + W \times h) \sin a.$$

Conversely, if weights are removed from *above* the water-line W_1L_1 (say, W tons at a height h feet), the stability of a ship is *increased* by the change, and for an angle a

$$\text{III. Moment of statical stability} = (D \times GM + W \times h) \sin a.$$

Whereas, if the same weights are removed from an equal distance *below* WL , the stability is *decreased*; and

$$\text{IV. Moment of statical stability} = (D \times GM - W \times h) \sin a.$$

As an example, suppose a ship of 6000 tons displacement, with a metacentric height (GM) of $3\frac{1}{4}$ feet, to have additional

* For the full mathematical treatment of this subject, see the Paper previously mentioned (page 92, foot-note) on the "Geometry of Metacentric Diagrams."

guns, weighing 50 tons, placed on her upper deck, their common centre of gravity being 18 feet above water. Rule I. applies, and we have, for an angle a ,

$$\left. \begin{array}{l} \text{Original moment of statical} \\ \text{stability} \end{array} \right\} = 6000 \text{ tons} \times 3\frac{1}{4} \text{ feet} \times \sin a. \\ = 19,500 \text{ (foot-tons)} \times \sin a.$$

$$\left. \begin{array}{l} \text{Moment of statical stability} \\ \text{after the addition of the} \\ \text{weights} \end{array} \right\} = (19,500 - 50 \times 18) \sin a. \\ = 18,600 \text{ (foot-tons)} \times \sin a.$$

Suppose the same ship to have 100 tons of water ballast added, instead of the guns, the centre of gravity of the ballast being 16 feet below the water-line. Then Rule II. applies, and the stability is increased, becoming for angle a

$$\left. \begin{array}{l} \text{Altered moment of statical} \\ \text{stability} \end{array} \right\} = (19,500 + 100 \times 16) \sin a. \\ = 21,100 \text{ (foot-tons)} \times \sin a.$$

It is unnecessary to give illustrations of the remaining rules for the removal of weights.

When "metacentric diagrams," such as those given on page 93, are available, the foregoing rules cease to be of much value; because the effect upon the vertical position of the centre of gravity of the addition or removal of any weights, however large, is easily estimated; the corresponding change in draught can be determined; and the new position of the metacentre corresponding to the altered draught is indicated on the metacentric diagram. Where no metacentric diagrams are available, the approximate rules given above will be of service to a commanding officer.

These various cases include the most important practical applications of the metacentric method to the stability of ships inclined transversely. Attention must next be turned to longitudinal inclinations, or changes of trim. The process by which the naval architect estimates *changes of trim* produced by moving weights already on board a ship is identical in principle with the inclining experiment described on page 99; only in this case he makes use of a metacentre for longitudinal inclinations (or, as it is usually termed, the "longitudinal metacentre"), instead of the transverse metacentre with which we have hitherto been concerned. The definition of the metacentre already given for transverse inclinations is, in fact, quite as applicable to inclinations in any other direction, longitudinal or skew; but it has already been explained

that, as the transverse stability of a ship is her minimum, while the longitudinal stability is her maximum, only these two need be considered.

The general expression for the height of the longitudinal meta-centre above the centre of buoyancy resembles in form that given on page 88, for the transverse metacentre; but for longitudinal inclinations the moment of inertia of the plane of flotation has to be taken about a transverse axis passing through the centre of gravity of that plane. Hence, using the same notation as before, we may write:

$$\left. \begin{array}{l} \text{Moment of inertia of plane of flotation (for} \\ \text{estimates of height of longitudinal meta-} \\ \text{centre)} \end{array} \right\} = K_1 \times B \times L^3.$$

$$\left. \begin{array}{l} \text{Height of longitudinal meta-} \\ \text{centre above centre of} \\ \text{buoyancy} \end{array} \right\} = \frac{K_1 \times B \times L^3}{\text{Volume of Displacement.}}$$

Following out a process of reduction similar to that described for the transverse metacentre, this last formula may be written

$$\text{Height of longitudinal metacentre} = \frac{K_1 \times B \times L^3}{C \times L \times B \times D} = b \cdot \frac{L^2}{D}.$$

The values of K and C vary considerably in different classes of ships; and so does the ratio b ; but the following averages obtained for various types may be of some value, although no approximations can be trusted to replace exact calculations from ship-drawings:—

	Values of b .
Unarmoured war-ships and merchant-ships of ordinary proportions07 to .08
Armoured ship; merchant ships of special classes075 to .09

The value .075 may be used as a rough approximation in most cases; but there are many exceptions to its use.

In ships of war the ratio of mean draught to length frequently lies between 1 to 12, and 1 to 14; the average of these ratios 1 to 13 is, as nearly as possible, the average value of b stated above. Hence, in such vessels, the height of the longitudinal metacentre above the centre of buoyancy usually approximates to equality with the length, in some classes exceeding it by 20 to 25 per cent., and in others falling below it by 10 to 15 per cent. In sea-going merchant ships the ratio of mean draught to length is usually less than in war-ships; and the height of the longitudinal metacentre above the centre of buoyancy is sometimes 40 per

cent. greater than the length. In vessels of extremely shallow draught, such as river steamers having small displacements, but large moments of inertia of the planes of flotation, the height of the longitudinal metacentre is exceptionally great in proportion to the length. It need only be added that as ships lighten, the heights of their longitudinal metacentres usually increase considerably, and for merchant ships where the variations in draught are considerable, it is often found useful to construct "metacentric diagrams," for the *loci* of longitudinal metacentres resembling in character those described for transverse metacentres on page 91. For war-ships the changes from load to light draught are less considerable, and it is not customary to construct these longitudinal metacentric diagrams.

Damage to the skin of a ship, and the consequent admission of water to the interior, usually affects the longitudinal as well as the transverse stability; and the general remarks made on page 105, may also be applied here. It is evident, moreover, that the greatest loss of longitudinal stability must result from the flooding of compartments near the bow and stern, unless the buoyancy of the water-line area at the tops of these compartments is preserved by watertight flats or platforms, as explained on page 21. The moment of inertia, it will be remembered, consists of the sum of the products of each element of area of the plane of flotation by the *square* of its distance from the transverse axis passing through the centre of gravity of that plane; hence the most distant portions of the area contribute the largest part of the moment of inertia, and if their contributions are withdrawn that moment is considerably diminished. As an extreme example, the *Inflexible* may be again mentioned. When the unarmoured ends are intact, the longitudinal metacentre of that ship is 292 feet above the centre of buoyancy; but when the ends are "riddled" the corresponding height is reduced to rather less than 33 feet.

A comparison of the statements made respecting the heights of the transverse and longitudinal metacentres, will show how much greater is the longitudinal than the transverse stability of ships. An example may enforce the contrast. The *Warrior*, has a longitudinal metacentric height of about 475 feet against a transverse metacentric height of 4.7 feet. To incline her 10 degrees longitudinally would require a moment one hundred times as great as would produce an equal inclination transversely. Or, to state the contrast differently, the moment which would hold the ship to a steady heel of 10 degrees would only incline her longitudinally about $\frac{1}{10}$ degree, equivalent to a change of trim of 6 or 8 inches on a length of 380 feet.

In Figs. 40, 41, are given illustrations of the change of trim produced by moving weights already on board a ship; but, before proceeding further, it may be well to repeat the explanation given in an earlier chapter of the term "change of trim." The *difference of the draughts* of water forward and aft (which commonly takes the form of excess in the draught aft) is termed the trim

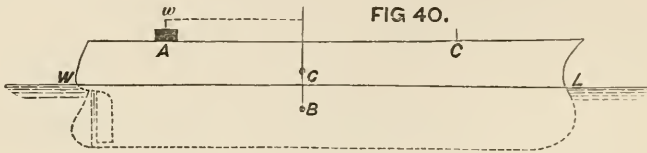

of the ship. For instance, a ship drawing 23 feet forward and 26 feet aft is said to trim 3 feet by the stern. Suppose her trim to be altered, so that she draws 24 feet forward and 25 feet aft, the "change of trim" would be 2 feet, because she would then trim only one foot by the stern. In short, "change of trim" expresses the sum of the increase in draught at one end and decrease in draught at the other; so that, if the vessel be inclined longitudinally through an angle α , and L be her length,

$$\text{Change of trim} = L \times \tan \alpha.$$

Suppose the height of the longitudinal metacentre above the centre of gravity to be GM , as in Fig. 41, then, when the weight

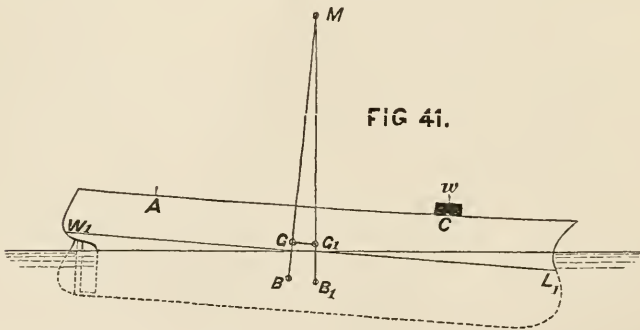

w is shifted longitudinally along the deck from A to C through a distance d , we shall have, by similar reasoning to that given in the case of the inclining experiment, the centre of gravity moving parallel to the deck, and

$$\text{Shift of centre of gravity } (GG_1) = \frac{w \cdot d}{D};$$

also

$$GG_1 = GM \tan a = \frac{w \cdot d}{D}; \text{ whence } \tan a = \frac{w \cdot d}{D \times GM};$$

and from the above expression,

$$\text{Change of trim} = L \times \tan a = \frac{w \cdot d}{D} \times \frac{L}{GM}.$$

Take the case of the *Warrior*, for which, at a draught of $25\frac{1}{2}$ feet, length = $L = 380$ feet; metacentric height = $GM = 475$ feet; displacement = 8625 tons. Suppose a weight (w) of 20 tons to be shifted longitudinally 100 feet,

$$\text{Change of trim} = \frac{20 \times 100}{8625} \times \frac{380}{475} = \cdot 186 \text{ foot} = 2\frac{1}{4} \text{ inches.}$$

It is usual to obtain for a ship the value of the "moment to change the trim one inch," when floating at the load-draught; and then for changes of trim up to 2 or 3 feet no great error is involved in assuming that for a change of trim of any number of inches the moment required will equal that number of times the moment which will change the trim one inch. Substituting in the equation,

$$\text{Change of trim} = \frac{w \cdot d}{D} \times \frac{L}{GM},$$

one inch as change of trim (i.e. $\frac{1}{12}$ foot), we have,

$$\frac{1}{12} = \frac{w \cdot d}{D} \times \frac{L}{GM}; \text{ whence } w \cdot d = \frac{D}{12} \times \frac{GM}{L}$$

Here $w d$ = moment to change trim one inch. In war-ships of ordinary proportions, as explained on page 110, the height, GM , approaches to equality with the length, L , and the following rule holds with a fair degree of approximation:—"The moment to change the trim of a war-ship one inch—that is, the product of the weight moved by the longitudinal distance it is shifted—will very nearly equal (in foot-tons) one-twelfth of the ship's displacement (in tons)." In long fine vessels like the *Warrior*, this rule will give results rather below the truth, because GM is greater than L , whereas in short full ships its results will be rather in excess, because GM is less than L . In the *Warrior*, for example, where the metacentric height is proportionately great, $\frac{1}{12} \times D = 718$; whereas the moment to change trim one inch is 898 foot-tons. In the *Hotspur*, on the contrary, $\frac{1}{12} \times D = 334$; whereas the moment to change trim is 300 foot-tons, the metacentric height in this case being 211 feet, and the length 235 feet. In sea-going merchant ships the

moment to change trim one inch would probably be 30 to 40 per cent. in excess of the approximate rule; and clearly that rule does not apply to shallow-draught vessels or special types.

The conditions are rather more complicated when weights are to be added to a ship, being placed with their centre of gravity in a certain known position, and it is required to determine the resultant draughts of water at the bow and stern. A good approximation may, however, be made as follows, supposing that the weights added are small when compared with the total weight of the ship—a supposition which will be fair in most cases. First, suppose the weights to be placed on board directly over the centre of gravity of the load-line section of the ship; then the vessel will sink bodily without change of trim, until she reaches a draught giving an addition to the displacement equal to the weights added. This can be estimated by the method of tons per inch immersion previously explained. The centre of gravity of the load-line section, or plane of flotation, usually lies a few feet abaft the middle of the length of the ship at the water-line, say, from one-thirtieth to one-fiftieth of the length abaft the middle. Having supposed the weights concentrated over this point, the next step is to distribute them, moving each to its desired position; each weight is multiplied by the distance it would have to be moved either forward or aft, and the respective sums of the products forward and aft being obtained, their difference is ascertained, this difference constituting the “moment to change trim.” The final step is to estimate the resultant change of trim due to this moment by the metacentric method previously explained. For example, take the *Warrior*, and suppose the following weights to be placed on board:—

Weight.	Distance from Centre of Gravity of Plane of Flotation.	Products.	
		Before.	Abaft.
Tons.	Feet.		
10	140	1400	..
30	120	3600	..
20	40	800	..
40	5	200	..
60	8	..	480
50	60	..	3000
25	100	..	2500
15	120	..	1800
250	..	6000	7780
			6000
Moment to change trim (by the stern)		..	1780

Moment to change trim one inch (say) = 890 foot-tons ;

$$\therefore \text{Change of trim} = \frac{1780}{890} = 2 \text{ inches ;}$$

$$\left. \begin{array}{l} \text{Increase in mean} \\ \text{draught} \end{array} \right\} = \frac{\text{Weights added}}{\text{Tons per inch}} = \frac{250}{41} = 6 \text{ inches.}$$

If the original draught of water was 25 feet forward, and 26 feet aft, mean $25\frac{1}{2}$ feet, the altered mean draught will be 26 feet, and the corresponding draught forward will be about 25 feet 5 inches and aft 26 feet 7 inches.*

A vessel partially water-borne and partly aground loses stability as compared with her condition when afloat. One of the commonest illustrations of this fact is found in the case of boats run bow-on to a shelving beach ; and instances are on record where vessels in dock have fallen over on their sides in consequence of a similar loss of stability,† when just taking or leaving the blocks, and not supported by side-shores, while the water was being admitted to or pumped out of the docks. For our present purpose it will suffice to indicate in general terms the conditions influencing the loss of stability. When afloat, the ship is wholly supported by the buoyancy due to the water she displaces ; when her keel touches the blocks or ground, she is partly supported by the upward pressure at that point, the remainder of her weight being supported by the water then displaced, which is by supposition less than the total displacement due to her weight. Having given the height to which the water rises on the ship at any instant, it is easy to estimate the corresponding buoyancy ; then the difference between it and the weight of the ship measures the pressure at the point of contact, and corresponds to the buoyancy contributed by the volume of the ship lying between her load-line when afloat and the actual water-line at the time she is partly water-borne. What has really been done, therefore

* To be exact, the alterations in draught forward and aft should be proportioned to the distances of the centre of gravity of the water-line plane from bow and stern.

† A well-known case is that of her Majesty's troopship *Perseverance*, which fell over on her side when being undocked at Woolwich some years ago. The matter was fully investigated at

the time by Mr. Barnes (now Surveyor of Dockyards at the Admiralty), and he has since contributed an article on the same subject to the *Annual of the Royal School of Naval Architecture* (see page 85 of No. 4). To this article, readers desirous of fully understanding the mathematical treatment of the case may turn with advantage.

is to transfer the buoyancy of this zone (acting through the centre of gravity of the zone) down to the point of contact of the keel with the ground. And when the vessel is inclined through a small angle from the upright, this pressure actually tends to upset her, whereas the buoyancy it has replaced would usually tend to right her. Hence the decreased stability.

It is possible to obtain a ready rule for estimating the loss. Suppose—

P = pressure of end of keel on ground ;

h = height of centre of gravity of the aforesaid zone above the point of contact of the keel and ground ;

W = total weight of ship.

Then a simple mathematical investigation shows that—

$$\left. \begin{array}{l} \text{Loss of metacentric height (GM) due to partial} \\ \text{grounding (approximately)} \end{array} \right\} = \frac{Ph}{W}.$$

Take as an example the case of the *Perseverance* for which

$$P = 51 \text{ tons ; } W = 1303 \text{ tons ; } h = 13 \text{ feet,}$$

$$\therefore \text{Loss of metacentric height} = \frac{51 \times 13}{1303} = 6 \text{ inches (about).}$$

Vessels having a very considerable normal trim by the stern are most liable to this kind of accident, and the upsetting tendency due to the pressure reaches its maximum when the vessel is about to take the ground along the whole length of the keel. The practical method of guarding against such accidents of course consists in carefully shoring, using mast-head tackles, or otherwise supporting the vessel externally, in order to prevent her from upsetting.

Up to this point attention has been directed exclusively to the stability of ships inclined to angles lying within the limits to which the metacentric method applies. For longitudinal inclinations, except in very special cases, nothing further is required ; but for transverse inclinations it is necessary to ascertain the statical stability at greater angles, and to determine the inclination at which the ship becomes unstable. The general principles previously laid down for determining the moment of the couple formed by the weight and buoyancy apply to all angles of inclination ; and it is consequently only necessary to fix for any angle the vertical line, passing through the centre of buoyancy, along which the resultant upward pressure of the water

acts. This is done by calculation from the drawings of a ship, and involves considerable labour; but the principle upon which it is based may be simply explained. Fig. 42 shows the cross-section of a ship which, when upright, floated at the water-line W_1L_1 , having the volume of displacement indicated by W_1XL_1 , and the centre of buoyancy B_1 . When inclined as in the diagram, WL is the water-line, WXL the volume of displacement, and B the corresponding centre of buoyancy. Since the displacement remains constant, the volumes WXL and W_1XL_1 are equal, and they have the common part WSL_1XW . Deducting this common part, the remainder (W_1SW) of the volume W_1XL_1 must equal the remainder (LSL_1) of the volume WXL ; or, as it is

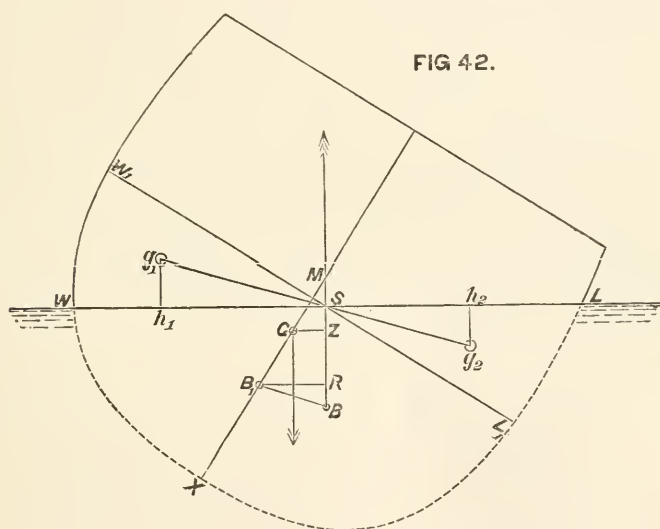

usually stated, the *wedge of immersion* LSL_1 must equal the *wedge of emersion* W_1SW . In other words, the inclination of the vessel has produced a change in the form of the displacement equivalent to a transfer of the wedge WSW_1 to the equal, but differently shaped, wedge LSL_1 . This is obviously a parallel case to that of the lever explained on page 99. In Fig. 42, let g_1 be the centre of gravity of the wedge of emersion, g_2 that of the wedge of immersion, and v the volume of either wedge; then what has been done is equivalent to a transfer of this volume v to the immersed side, into the position having g_2 for its centre of gravity. The moment due to this shift = $v \times g_1g_2$; and its consequence is a motion of the centre of gravity of the total volume

of displacement V from the original position, B_1 , to the new one, B , the line B_1B being parallel to g_1g_2 , and the length

$$BB_1 = \frac{v}{V} \times g_1g_2.$$

It thus becomes obvious that, when the positions of the centres of gravity of the wedges (g_1 and g_2) for any inclination are known, the new position of the centre of buoyancy (B) can be determined with reference to its known position (B_1) when the ship is upright. And this is virtually the process adopted in the calculation.* If B_1R be drawn perpendicular to BM , Fig. 42, and g_1h_1, g_2h_2 perpendicular to WL , then, by the same principle as is used above, the length $B_1R = \frac{v}{V} \times h_1h_2$.

Also, if the angle of inclination WSW_1 be called a ,

$$GZ = B_1R - B_1G \sin a,$$

and, consequently,

$$\begin{aligned} \text{Moment of statical stability} &= V \times GZ = V(B_1R - B_1G \sin a) \\ &= v \times h_1h_2 - V \times B_1G \sin a. \end{aligned}$$

This expression for the righting moment (in terms of the volume of displacement) is known as "Atwood's formula," and is commonly employed in constructing "curves of stability."

FIG. 43.

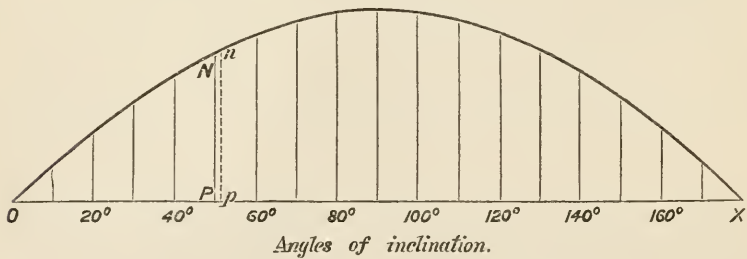

Fig. 43 shows the method of construction for such a curve. On the base-line OPX degrees of inclination are set off on a certain scale, O corresponding to the upright; the ordinate of the curve drawn perpendicular to the base-line at any point measures, on a certain scale, the "arm of the righting couple" (GZ) for the corresponding angle of inclination. Thus, OP represents an

* For details of the method of calculation, see a Paper contributed by Mr. W. John and the Author to the *Transac-*

tions of the Institution of Naval Architects for 1871.

inclination of 50 degrees, and the corresponding ordinate PN represents the length of the arm of the couple formed by the weight and buoyancy at that inclination. By calculation, successive values of GZ are found for inclinations differing by an interval of 8 or 10 degrees; and the curve is drawn through the tops of the ordinates thus found. Measurement of the ordinates renders any calculation unnecessary for inclinations other than those made use of in drawing the curve. It will be observed that, starting from the upright position the stability gradually increases, reaches a maximum value, and then decreases, finally reaching a zero value (where the curve crosses the base-line) at the inclination where the ship becomes unstable. The preceding explanation of the causes governing the position of the centre of buoyancy will furnish the reason for this gradual increase and after decrease in the stability. The length (OX) measuring the inclination at which the ship becomes unstable determines what is known as the *range* of stability for the ship, and this is an important element of safety.

One of the simplest illustrations of a curve of stability is that for the cigar-ship shown in section by Figs. 32, 33, page 96. In such vessels, as previously explained, for any angle, α , $GZ = GM \sin \alpha$, and the curve of stability is constructed by simply setting up, at any point on the base-line, a length representing the sine of the angle of inclination corresponding to that point. Fig. 43 shows this curve. The range is 180 degrees; the maximum stability is reached at 90 degrees, and the curve is symmetrical about its middle ordinate. Variations in the values of the metacentric height (GM) affect all the ordinates of the curve in the same proportion.

Ship-shaped forms are less easy to deal with; but a brief explanation of the causes chiefly influencing the form and range of curves of stability in ships will be of value. These causes may be grouped under the following heads:—(1) Freeboard; (2) beam; (3) the vertical position of the centre of gravity; (4) the vertical position of the centre of buoyancy when the ship floats upright. Both freeboard and beam are of course relative measures, and should be compared with the draught of water. With freeboard, moreover, must be associated the idea of “reserve of buoyancy” (see page 9). The vertical position of the centre of gravity must be compared with the *total depth* of the ship (excluding projecting keel), and so must that of the centre of buoyancy. It is also necessary to note the relation between the mean draught and the depth of the centre of buoyancy below the

water-line, as that relation indicates roughly the fulness or fineness of form in the under-water portion of the ship. Before giving any illustrations of curves of stability for actual ships, a few simple examples may be taken from box-shaped vessels in order to show the relative influence of the above-mentioned features. The following cross-sections will serve the purpose:—

Dimensions.	No. 1.	No. 2.	No. 3.
Beam	Feet. 50½	Feet. 50½	Feet. 57½
Draught	21	21	21
Freeboard	6½	13½	6½
Metacentric height (GM)	2·6	2·6	5

Taking No. 1 as a standard for comparison, its curve of stability is shown by A in Fig. 44. The effect of adding 7 feet to the freeboard—supposing the centre of gravity to be unchanged in position—is seen by comparing the curve of stability B for No. 2 with the curve A.

FIG. 44.

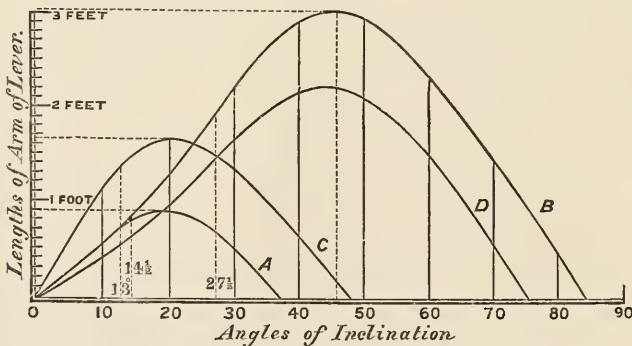

Similarly, the effect of adding 7 feet to the beam is seen by comparing the curve of stability C for No. 3 with the other two curves. Only a few further words of explanation will be necessary.

At an inclination of 14½ degrees, the “deck-edge,” or angle, of No. 1 will be immersed; for No. 2 the corresponding inclination is nearly doubly as great, viz. 27½ degrees. Fig. 45 shows No. 2 with its deck-edge “awash.” Fig. 46 shows No. 1 at the same inclination, with a considerable portion of its deck immersed. Up to the inclination, when the deck-edge of either vessel is just

immersed, the centre of buoyancy *B* moves steadily outward in relation to the centre of gravity as the inclination increases, in consequence of the gradual increase in the volume of the wedges of immersion and emersion, and in the distance g_1g_2 between their centres of gravity. But after the deck goes under water, this outward motion of the centre of buoyancy relatively to the centre of gravity becomes slower, or is replaced by a motion of return, in consequence of the decrease in the distance g_1g_2 between the centres of gravity and the less rapid growth of the volumes of

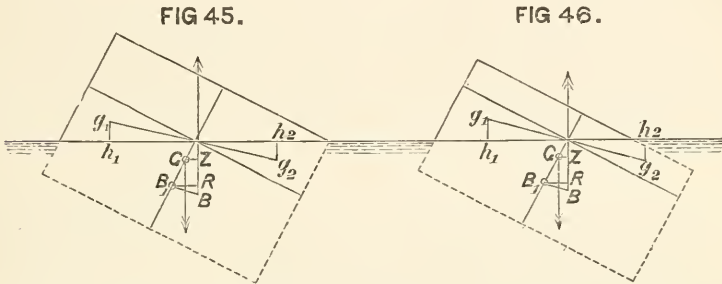

the wedges. The increase in value of the term $B_1G \sin a$ in the formula,

$$V \times GZ = v \times h_1h_2 - V \cdot B_1G \sin a,$$

also tends to diminish *GZ* as the inclination increases. The greater the angle of inclination corresponding to the immersion of the deck-edge—in other words, the higher the ratio of free-board to breadth—the greater will be the inclination at which the statical stability reaches its maximum value. Up to $14\frac{1}{2}$ degrees, the curves *A* and *B* in Fig. 44 are identical; but then *B* continues to rise rapidly, not reaching its maximum until 45 degrees, whereas *A* reaches its maximum at 20 degrees. The low-freeboard box, moreover, has a range of less than 40 degrees, whereas the high-freeboard box (No. 2) has a range of 84 degrees.

Turning to No. 3 section, and the curve of stability *C*, it will be noticed that the increase of 7 feet in beam causes a considerable increase in the metacentric height (*GM*). For moderate inclinations, $GZ = GM \sin a$, and therefore this increase in *GM* is accompanied by a corresponding increase in the steepness of the earlier part of the curve of stability *C*, as compared with the curves *A* and *B* in Fig. 44. The deck-edge becomes immersed, however, at 13 degrees, the maximum stability is reached at 20 degrees, and the range of stability is less than 50 degrees as

against 84 degrees in curve B for the higher freeboard vessel.* The comparison of these curves will show how much more influential increase of freeboard is than increase of beam in adding to the amount and range of the statical stability of ships.

Lastly, to illustrate the effect of the vertical position of the centre of gravity upon the forms of curves of stability, let it be assumed that the high-freeboard vessel (No. 2 section) has its centre of gravity raised one foot, leaving the value of the meta-centric height (GM) 1.6 foot. This will be no unfair assumption, seeing that the increase in freeboard, and consequently in total depth, would in practice be associated with a rise in the centre of gravity. The curve of stability D, Fig. 44, corresponds to this last case. For each inclination the decrease in the arm of the righting couple, as compared with curve B, is given by the expression,

$$\text{Decrease in } GZ = GG_1 \times \sin a,$$

There GG_1 (rise in position of centre of gravity) is one foot. Initially the curve D falls within A and B, the vessel being more crank. It has, however, its maximum ordinate at 45 degrees, and a range of 75 degrees, comparing very favourably indeed with the curve C for the low-freeboard vessel with broad beam (No. 3). The reader will have no difficulty in making a more detailed comparison of the curves for these representative vessels, should that be considered desirable.

Turning from these simple prismatic forms to actual ships, it will be interesting to notice how the curves of stability for different classes of ships illustrate the varying influence of beam, freeboard, vertical position of the centre of gravity, &c. The earliest curves of stability on record were constructed at the Admiralty in 1867, prior to which date there appears to have been no exact determination of the stability of ships at large angles of inclination when their upper decks were partially under water, or of their ranges of stability. So long as ships of high freeboard were employed exclusively this limitation of inquiry as to variation in statical stability was natural enough; but when low-freeboard vessels came into use the necessity arose for more extended calculations, in order to determine the angles of inclination, at which the vessels became unstable. Since 1870 the

* A full discussion of this subject will be found in a Paper contributed to vol. xii. of the *Transactions* of the Institution of Naval Architects by Mr.

Barnaby, C.B., Director of Naval Construction. Some of the preceding illustrations are borrowed from this paper.

practice of constructing curves of stability for each class of vessel in the Royal Navy has been established; and has been imitated in foreign navies. More recently similar curves have been constructed for yachts and for various classes of merchant ships. A large amount of valuable data has thus been accumulated already, and important additions are continually being made thereto.

The first set of illustrations of curves of stability, contained in Fig. 47, is limited to representative types of war-steamers, and to

FIG. 47.

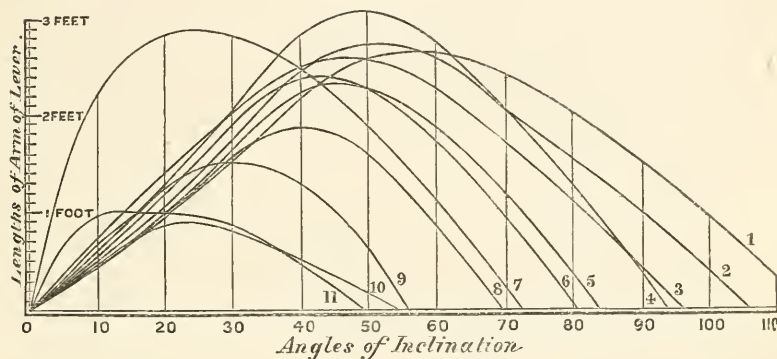

- | | |
|-----------------------|------------------------|
| 1. <i>Juno.</i> | 7. <i>Miantonomoh.</i> |
| 2. <i>Inconstant.</i> | 8. <i>Monarch.</i> |
| 3. <i>Endymion.</i> | 9. <i>Devastation.</i> |
| 4. <i>Serapis.</i> | 10. <i>Captain.</i> |
| 5. <i>Invincible.</i> | 11. <i>Glatton.</i> |
| 6. <i>Achilles.</i> | |

their fully-laden condition. In all cases the centres of gravity have been ascertained by experiment; and the distribution of the weights is accurately known. Those weights are supposed to be secured in such a manner that no shift takes place even at the most extreme inclinations. This may be considered an improper supposition, especially in cases where stability is maintained beyond the inclination of 90 degrees from the upright; but it is to be observed that such extreme inclinations are not likely to be reached, whereas for less inclinations the supposition affects all classes similarly. Further, it is assumed in making the calculations that throughout the inclinations no water enters the interior through ports, scuttles, hawse-pipes and other openings in the sides; or through hatchways, ladder-ways, and other openings in the decks. This assumption is fair enough as regards most of the openings, which are furnished with watertight covers, plugs, &c.; and as regards some of the hatchways which are

usually kept open even in a seaway it is only necessary to remark that they might be battened down on an emergency, while their situation near the middle line of the deck prevents the water from reaching them except at very large angles of inclination. It is not usual to include erections above the upper decks of war-ships in making calculations for curves of stability unless they are thoroughly closed in and made watertight. For example, deck-houses, open-ended forecastles and poops, &c., are not included; but closed batteries, breastworks, forecastles and poops are reckoned in the contributories to stability. These partially watertight erections no doubt aid the ships in recovering from extreme lurches, &c., which put them under water only for very short periods, so that their omission from the calculation is on the side of safety. The following table gives the principal dimensions, &c., of these representative war-steamships:—

Name.	Class of Ship.	Length.	Breadth Extreme.	Mean Draught.	Height of Upper Deck Amidships above Water.	Displacement.
<i>Unarmoured.</i>						
<i>Eudymion</i> . . .	Old type steam frigate . . .	240	47 10	20 6	14 8	3300
<i>Juno</i> . . .	Covered-deck corvette . . .	200	40 0	17 4	14 6	2215
<i>Inconstant</i> . . .	Swift cruising frigate . . .	337	50 3½	23 10½	15 3½	5782
<i>Serapis</i> . . .	Indian troopship . . .	360	49 0	19 5	15 0	5976
<i>Armoured.</i>						
<i>Glatton</i> . . .	Breastwork monitor . . .	245	54 0	18 9	3 0	4912
<i>Miantonomoh</i> . . .	American monitor . . .	250	52 10	14 0	3 0	3842
<i>Captain</i> (late)	Low-freeboard	320	53 3	25 0½	6 6	7790
<i>Monarch</i> . . .	High-freeboard } turret-	330	57 6	24 1½	14 0	8215
<i>Devastation</i> . . .	Mastless } ships. {	285	62 3	26 1½	11 3*	9061
<i>Achilles</i> . . .	Early type } broadside	380	58 3½	26 5	15 0	9484
<i>Invincible</i> . . .	Later type } ships {	280	54 0	22 6	16 0	6060

* Only 4½ feet aft.

In Fig. 47 the respective curves of stability for these vessels appear with reference numbers, enabling them to be distinguished; and they will repay a careful study, as illustrations of the comparative stabilities of high- and low-sided vessels, armoured and unarmoured. It will be remarked that the ordinates of the curves have to be multiplied by the respective displacements of the ships in order to obtain the righting moments.

As ships of war lighten by the consumption of coals, provisions, stores, &c., their curves of stability usually lose in area and range. This is due to the fact that the rise in the vertical position of the centre of gravity as the ships lighten usually

produces a greater effect in reducing the stability, than the increase in freeboard produces in the contrary sense. Any such decrease in stability can be prevented in ships fitted to carry water ballast as all armoured ships are; but as a rule there is no necessity to use water ballast even in the extreme light condition. There are, moreover, exceptions to the rule just stated: some types having little, if any, less stability in the light condition than they have when fully laden. As an example, reference may be made to the two curves for the *Inflexible* in Fig. 47a. The

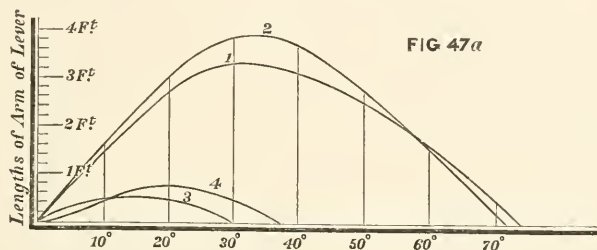

FIG 47a

References.

- | | |
|---------------------------------|----------------------------------|
| 1. Load condition, ends intact. | 3. Load condition, ends riddled. |
| 2. Light " " " | 4. Light " " " |

curve (1) shows the ship fully laden, and the curve (2) indicates her condition when 1500 tons of coals and consumable stores have been removed. This diagram also illustrates the influence which damage to the skin of a ship and the consequent entry of water into the hold may have upon the form and range of her curve of stability. The curves 3 and 4 show the conditions of statical stability of the *Inflexible* when the unarmoured ends are completely riddled. This extensive damage would cause the ship to sink more than 2 feet below her ordinary load-line, reducing her freeboard by an equal amount, and lessening her stability very greatly. The tabular statement on the following page will supplement the information given in the diagram.*

This is an extreme illustration of the loss of stability due to damage to the skin of a ship; but similar considerations hold good in all ships, and the extent to which their stability may be decreased by collision or other accident can be readily estimated when the extent of the damage is known. Without any actual damage to the skin of a ship water may find its way into the

* For a full discussion of the statical stability of this ship see the Report of the Committee of 1878 (*Parliamentary Paper*).

interior through open ports or scuttles in the sides, or open hatchways in the decks, the result being a more or less serious decrease in stability. Such occurrences are clearly exceptional, but they have happened in ships caught by squalls of wind in com-

Condition of Inflexible (see Fig. 47a).	Draught.	Displacement.	Deck enters Water.	Angle of Maximum Stability.	Maximum Value of GZ.	Range of Stability.	Metacentric Height (GM.)
	Feet. ins.	Tons.			Feet.		Feet.
1. Fully laden, ends intact	24 7	11,500	14°	31°·2	3·28	74°·3	8·25
2. Light condition, ends intact	21 10	10,000	18°	31·7	3·98	71·5	8·5
3. Fully laden, ends riddled	26 8½	11,500	11°	13·5	·57	30·0	2·0
4. Light condition, ends riddled	23 9	10,000	15°	20·8	·79	36·8	2·22

paratively smooth water. The *Eurydice* is an example. Fig. 47c, page 128, shows two curves of stability for that ill-fated vessel. The first, marked 3, is the curve for her fully-laden condition with all ports closed, and openings in sides and decks made watertight :

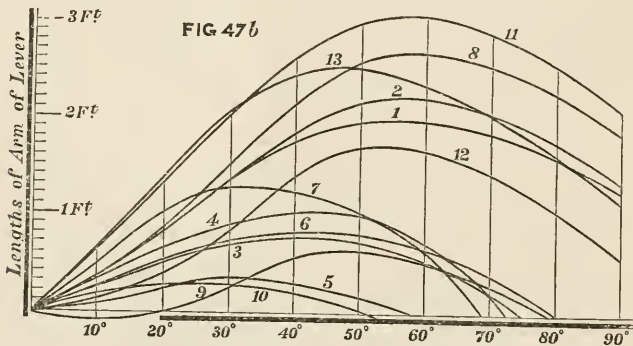

Curves of stability for merchant steamers.

Note.—The dimensions, &c., of these vessels appear in the Table on page 127 under the respective reference numbers marked on the curves.

the second, marked 4, is the curve corresponding to her condition when she was capsized, the ports having been open, and the water having entered through them. In curve 3, the freeboard (to the upper deck) was between 11 and 12 feet; whereas in curve 4 the freeboard was virtually reduced to 4 feet. Having regard to the

explanations given on page 120, as to the influence of freeboard on range of stability, the reduction of range and area of the curve of stability from 3 to 4 in Fig. 47c will be fully understood.

Turning from war-ships to merchant ships, it is not possible to give similarly full and exact information respecting their curves of stability. The principal reasons for this difference have been stated on page 80. In Fig. 47b there are given, however, the curves for a considerable number of representative merchant steamships,

PARTICULARS OF THE VESSELS WHOSE CURVES OF STABILITY ARE GIVEN IN FIG. 47b.

Reference to Curve.	Class of Ship.	Length.	Extreme breadth.	Mean draught.	Meta-centric height.	Height of upper deck amidships above water.	Displacement.
		Ft. ins.	Ft. ins.	Ft. ins.	Feet.	Ft. ins.	Tons.
1	{ Long, swift steamer, miscellaneous cargo }	390·0	39·0	23·0	2·0	8·6	6400
2	{ Steamer of moderate speed, miscellaneous cargo }	320·0	34·0	18·3	2·0	8·5	3560
3	{ Steamer of moderate speed, homogeneous cargo }	264·0	32·0	18·9½	1·1	5·2	3220
4	{ Same vessel, but in light condition }	„	„	8·11	1·5	15·0½	1240
5	{ Steamer, large carrying power, homogeneous cargo }	320·0	40·0	23·6	0·4	6·1½	6380
6	{ Same vessel, 300 tons less cargo, and 300 tons water ballast }	„	„	„	1·2	„	„
7	{ Same vessel, light condition }	„	„	9·7	3·0	21·0½	2110
8	{ Passenger steamer, miscellaneous cargo }	312·6	33·4	16·3	2·0	9·8	2870
9	{ Same vessel, assumed initially unstable }	„	„	„	-0·5	„	„
10	{ Steamer, grain cargo }	245·0	33·4	19·0	0·7	4·0	3600
11	{ Steamer, cargo of iron }	285·0	35·4	18·0	3·5	6·6	3800
12	{ Steamer, grain cargo }	245·0	32·4	16·0	0·8	8·0	3100
13	{ Despatch vessel (<i>Iris</i>) }	300·0	46·0	19·9	3·7	8·7½	3735

laden to certain assumed load-lines, which are approximately those at which the ships would be worked. The nature of the stowage assumed in each case is explained in the tabular statement above, and the principal dimensions, &c., of the vessels are also recorded therein.*

* For a few of these examples of curves of stability the author is indebted to Mr. Martell's Paper on "Causes of Unseaworthiness" (*Transactions of the Institution of Naval Architects for 1880*). The remainder have been obtained by direct calcula-

tions for ships bought into the Royal Navy, and by calculations made by the Author's pupils at the Royal Naval College. For fuller details of certain of the last mentioned calculations see a Paper by the Author in *Transactions of the Institution of Naval Architects for 1881*.

To the foregoing illustrations of curves of stability for steamships may be added a few for sailing ships of various classes. Fig. 47c contains these additional curves, and in the accompanying tabular statement the principal dimensions, &c., of the vessels appear. They include a few examples of the now obsolete sailing ships of the Royal Navy, others of existing sailing ships of the mercantile marine, and others of typical yachts.* In nearly all

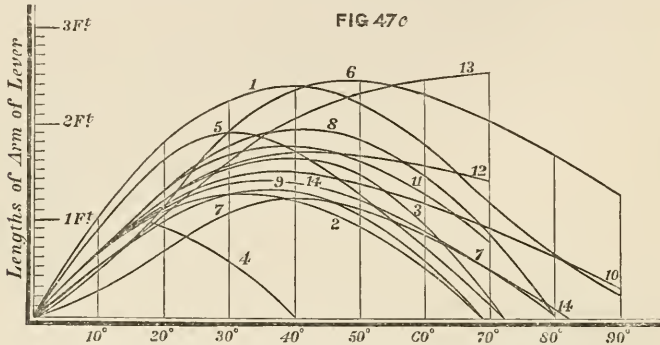

Curves of Stability for Sailing Vessels.

Note.—The dimensions, &c., of these vessels appear in the table on page 129, under the respective reference numbers marked on the curves.

cases the fully-laden condition is taken. For the yachts and warships the stowage is accurately known, so that the curves strictly correspond to the actual condition of the vessels in their sea-going trim. For the merchant ships a stowage has necessarily been assumed, which is thought to be fairly representative of the ordinary condition. It is probable, however, that in some cases these merchant ships are stowed so that they have greater stability than is indicated on the diagram, and in other cases less stability. To illustrate these possible variations, the curves 6 and 7, or 8 and 9 may be taken. In curve 6 the centre of gravity is supposed to be 1.7 feet lower than in curve 7; and in the second example the centre of gravity for curve 8 is 1 foot lower

* For the facts as to sailing yachts the author is indebted to the valuable researches of Mr. Dixon Kemp; for those relating to the *Sunbeam* he has to thank Sir Thomas Brassey: most of those as to merchant sailing ships are taken from the Report of the

Atalanta Committee, to whom they were presented by Mr. W. John. The curves 6 and 7 were calculated by the Author's pupils at the Royal Naval College for the ship built by Messrs. A. & J. Inglis, of which the metacentric diagram appears in Fig. 30d.

than for curve 9. The draught of water is the same in curves 6 and 7, or in curves 8 and 9; and the differences in stability arise entirely from variations in the vertical position of the centre of gravity, as explained on page 122.

PARTICULARS OF THE VESSELS WHOSE CURVES OF STABILITY ARE GIVEN IN FIG. 47c.

Reference to Curve.	Class of Ship.	Length.	Ex-treme breadth.	Mean draught.	Meta-centric Height.	Height of upper deck amid-ships above water.	Dis-placement.
		Ft. ins.	Ft. ins.	Ft. ins.	Feet.	Ft. ins.	Tons.
1	Sailing frigate, load condition .	131·0	40·7	17·4	6·2	10·9	1055
2	Sailing frigate, light condition.	„	„	16·0	4·1	12·1	887
3	{Sailing frigate, load condition, ports shut}	141·0	38·8	16·7	4·5	10·6	1075
4	{Sailing frigate, load condition, ports open}	„	„	„	„	„	„
5	Sailing brig, load condition . .	100·6	32·4	14·0 $\frac{1}{2}$	5·9	4·3 $\frac{1}{2}$	483
6	Sailing merchantman	222·0	35·4	16·9	3·0	5·3	2030
7	{Sailing merchantman, homo- geneous cargo, and no ballast}	„	„	„	1·3	„	„
8	Sailing merchantman	273·0	43·1	19·10	3·5	5·8	3980
9	Sailing merchantman	„	„	„	2·5	„	„
10	Small sailing merchantman . .	148·0	26·9	—	3·5	—	787
11	Yacht	81·3	20·6	9·5	4·0	2·11	128
12	Yacht	85·9	19·3	10·1	3·7	3·1	150
13	Yacht	100·0	16·7	9·4	3·3	3·10	158
14	{Yacht (with auxiliary steam power) <i>Sunbeam</i>}	154·9	27·1	13·0	3·45	4·4	576

In this connection it may be interesting to revert to the case of a ship which is unstable when upright, but yet has a considerable range of stability. Curve 9 in Fig. 47b. will illustrate this case. When the vessel is upright, the metacentre is 5 feet *below* the centre of gravity. Initially the curve of stability falls below the base-line, and this is a graphic representation of instability. At an inclination of 20 degrees the curve crosses the load-line, and thence onward, the vessel has a positive righting moment until, at 80 degrees, she once more becomes unstable. The position (20 degrees) at which the curve crosses the base-line, is one of stable equilibrium: the upright position and that where she is inclined 80 degrees correspond to unstable equilibrium. It is a general law under the conditions assumed in calculating curves of stability that positions of stable and unstable equilibrium occur alternately. The position of 20 degrees is that to which the vessel would "loll" over from the upright in still water; and if moved slightly from this position, either to greater or less angles of heel, she

would return to it as her position of rest. This condition may be reached either by altering the vertical distribution of weights in a ship so as to bring the centre of gravity above the metacentre, or by affecting the metacentre so as to bring it below the centre of gravity. The former case is more common, especially for merchant ships when floating light: the latter case may occur when ships are damaged by collision or in action, and water enters the interior.

In concluding these remarks on curves of stability brief reference may be made to a method of procedure that appears well-suited for dealing with the changing stowage of merchant ships. The designer commonly accepts a maximum load-draught on which a certain dead weight is to be carried. Although on actual service this load-line may be departed from very frequently, it may be used for purposes of calculation. Assuming the ship to be floating at this line and to have her cargo-spaces filled with homogeneous cargo, it is possible (as explained on page 95) to approximate to the vertical position of the centre of gravity, and to the value of the metacentric height. With these data a curve of stability may be constructed, and it will represent a condition of stowage less favourable to the vessel than any likely to occur in practice; while a very easy process enables one to pass from this curve to that corresponding to any other stowage of the same total dead weight. The case where both stowage and draught vary can also be dealt with readily by the naval architect. Very frequently, as we have seen, merchant ships have stability even on the beam-ends—90 degrees of inclination to the upright. Consequently, if it is desired to avoid the labour of calculating a complete curve of stability for them, a simple calculation may be made for this extreme position; and if the vessels then have righting moment or only a very small amount of instability, no further inquiry need be made. A sufficient amount of stiffness when upright, combined with such a range of stability as would thus be indicated, cannot fail to be satisfactory.

The much greater range of stability frequently possessed by merchant ships as compared with war-ships, and especially with some classes of armoured ships, is chiefly due to the very different vertical distribution of the weights. In the merchant ships the great weights of cargo, &c., are carried low down in the holds; and the centres of gravity consequently lie low in proportion to the total depth. In war-ships, on the contrary, although the weights of machinery, coals, ammunition, and projectiles, are carried low down in the holds, heavy loads of

armour, armament, &c., have to be carried high up on the sides or decks. As a consequence the centre of gravity lies higher (in proportion to the total depth) in war-ships, and especially in armoured ships, than it does in merchant ships, and this tends to diminish the range of stability. Further the deep lading of merchant ships brings the centre of buoyancy for the upright position higher in the ships than is usual in war-ships; and this diminishes the distance between the centre of buoyancy for the upright position and centre of gravity, consequently tending to lengthen the range of stability. In yachts these two features are still further exaggerated, the distance between the centres of gravity and centres of buoyancy being very small indeed, while the centres of gravity are drawn low down by the heavy weights of ballast fitted on the keels and floors.

CHAPTER IV.

THE OSCILLATIONS OF SHIPS IN STILL WATER.

IF a ship, floating in still water, has been inclined from a position of stable equilibrium by the action of external forces, and is afterwards allowed to move freely, she will perform a series of oscillations, the range of which gradually decreases, on either side of the position of equilibrium; and will finally come to rest. For all practical purposes attention may be limited to the case of the transverse inclinations and oscillations of ships, reckoning from the upright position where they are in stable equilibrium; and unless specially mentioned, it may be assumed that the following remarks deal only with rolling motions in still water, the other principal oscillations—viz. pitching—not taking place to any sensible extent except in a seaway.

There is an obvious parallelism between the motion of a ship set rolling in still water and that of a simple pendulum moving in a resisting medium. Apart from the influence of resistance, both ship and pendulum would continue to swing from the initial angle of inclination on one side of the vertical to an equal inclination on the other side; and the rate of extinction of the oscillations in both depends upon the resistance, the magnitude of which depends upon several causes to be mentioned hereafter. In what follows, the term "oscillation" will be used to signify a single swing of the ship from port to starboard, or *vice versa*.* The "arc of oscillation" will simply mean the sum of the angles on either side of the vertical swept through in a single swing; for instance, a vessel rolling from 12 degrees inclination to port,

* In the usual mathematical sense an oscillation would mean a double swing, say from port to starboard and back again to port; but the definition

in the text agrees with the practice of the Royal Navy in recording rolling motions, and is therefore followed.

and reaching 10 degrees inclination to starboard, would have ($10^\circ + 12^\circ$) 22 degrees as the arc of oscillation. The *period* of oscillation means the time occupied (in seconds, say) in performing a single swing.

No vessel can roll in still water without experiencing resistance to her motion; but considerable advantage results from first considering the hypothetical case of *unresisted* rolling, and afterwards adding the conditions of resistance. Rigorous mathematical reasoning may be applied to the hypothetical case, but this is not true of an investigation which takes account of the total resistance experienced by a ship when rolling; and the highest authorities are compelled to adopt a mixed method when dealing with resisted rolling, superposing, as it were, data obtained from experiments made to determine the effects of resistance, upon the mathematical investigations of the hypothetical case. No endeavour will here be made to follow out either part of the inquiry, as such a course involves mathematical treatment lying outside the province of this work; but it is possible in popular language to explain some of the chief results obtained, and this we propose to do.

Supposing the rolling of a ship in still water to be unresisted it may be asked, What is the length of the simple pendulum with which her oscillations keep time, or synchronise? It has been sometimes assumed that the comparison made in the previous chapter between a ship held in an inclined position and a pendulum of which the length is equal to the distance between the centre of gravity and the metacentre held at an equal inclination, will remain good when the ship and the pendulum are oscillating. In fact, it is supposed that the whole of the weight may be concentrated at the centre of gravity (G, Figs. 30 and 31, page 76), while the metacentre is the point of suspension for the ship in motion as well as for the ship at rest; but this is an error. If it were true, the stiffest ships, having the greatest heights of metacentre above the centre of gravity, should be the slowest-moving ships. All experience shows the direct opposite to be true. For example, a converted ironclad of the *Prince Consort* class, with a metacentric height exceeding 6 feet, will make twelve or thirteen single rolls per minute, and an American monitor, with a metacentric height of 14 feet, will make more than twenty single rolls per minute, while vessels like the *Hercules* or *Sultan*, with metacentric heights under 3 feet, will only make seven or eight rolls per minute. What is thus shown to be true by experience had been proved nearly a century

and a half ago, by the great French writer Bouguer, in his *Traité du Navire*.

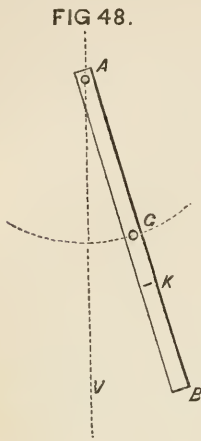

The necessity for carefully distinguishing between the cases of rest and motion in a ship may be simply illustrated by means of a bar pendulum (such as AB, Fig. 48) of uniform section, having its centre of gravity at the middle point, G. To hold the pendulum at any steady inclination to the vertical must require a force exactly equal to that required to hold at the same inclination a simple pendulum of length AG, and of equal weight to the bar pendulum. But if this simple pendulum were constructed, and set moving, it would be found to move much faster than the bar pendulum. The simple pendulum keeping time with

the bar instead of having a length AG equal to one-half of AB, will have a length AK equal to two-thirds of AB; and it is important to notice the causes producing this result.*

Suppose the pendulum to have reached one extremity of its swing, and to be on the point of returning: at that instant it will be at rest. As it moves back towards the upright, its velocity continually increases, reaching a maximum as the pendulum passes through the upright position, and afterwards decreasing until at the other extremity of the swing it will once more be instantaneously at rest. These changes of velocity, accelerations or retardations, from instant to instant can only be produced by the action of certain forces; and according to the first principles of dynamics, these changes of velocity really measure the intensity of the forces. For instance, a body falling freely from a position of rest acquires a velocity of rather more than 32 feet in a second; at the end of two seconds it has twice as great a velocity; and so on. This "rate of change of velocity"—some 32 feet per second—is regarded as a measure of the *uniform* accelerating force of gravity. For any other accelerating force the corresponding measure is expressed by the

* A *simple* pendulum, as previously explained, is one having all its weight concentrated at one point (the "bob"), and supposed to be hung from the centre of suspension (A, Fig. 48) by a weightless rod. The point K in Fig. 48 is termed the "centre of oscillation," and the bar pendulum will oscillate in the same time, whether it is hung at A or at K.

ratio which the rate of change of velocity produced by gravity bears to the change of velocity which would be produced by that accelerating force, if its action continued uniform for one second. For accelerating forces which are not uniform this mode of measurement gives a varying rate of change from instant to instant. In the case of the simple pendulum, the bob moves in a circular arc, having a radius equal to the length of the pendulum; hence the *linear* velocity of the bob in feet per second may be expressed in terms of the product of this radius into the *angular* velocity.* Similarly, the changes in velocity, measuring the accelerating forces, may be expressed in terms of the product of the radius into the changes of angular velocity. These accelerating forces at any instant act at right angles to the corresponding position of the pendulum rod; and so finally we obtain for the simple pendulum:—

$$\left. \begin{array}{l} \text{Moment of accelerating} \\ \text{forces about centre of} \\ \text{suspension . . .} \end{array} \right\} = C \times \text{weight of the bob} \times (\text{radius})^2 \\ \times \text{rate of change of angular} \\ \text{velocity ;}$$

where C is a constant quantity (viz. $\frac{1}{32}$, nearly—the reciprocal of the velocity per second due to gravity). Hence follows this important principle: for any heavy particle oscillating about a fixed axis the moment of the accelerating forces at every instant involves the product of the weight of the particle by the *square* of its distance from the axis of rotation.

Turning from the simple pendulum to the bar pendulum (Fig. 48), we may consider the latter as made up of a number of heavy particles, and take each separately. For example, take a particle of weight w at a distance x from the axis of rotation (A); the moment of the accelerating force upon it, about the point A, is given by the expression,

$$\text{Moment} = C \times w \times x^2 \times \text{rate of change of angular velocity.}$$

At any instant the change of angular velocity is the same for all particles in the bar-pendulum, whatever may be their distance from A; whence it follows that for the whole of the particles in the bar-pendulum—

$$\left. \begin{array}{l} \text{Moment of accelerating} \\ \text{forces at any instant .} \end{array} \right\} = C \times \text{weight of bar} \times k^2 \times \text{rate} \\ \text{of change of angular velocity.}$$

* The angular velocity may be defined as the angle swept through per second if the motion is uniform, or that which would be swept through per

second if the rate of motion existing at any instant were continued for a second. These angles are usually stated in circular measure.

To determine k^2 , we have only to sum up all such products as $w \times x^2$ for every particle in the bar, and divide the sum by the total weight of the bar. Or, using Σ as the sign of summation,

$$k^2 = \frac{\Sigma (wx^2)}{\text{Weight of bar}}$$

Turning to the case of a rigid body like a ship, oscillating about a longitudinal axis which may be assumed to pass through the centre of gravity, it is only necessary to proceed similarly. Take the weight of each elementary part, multiply it by the square of its distance from the axis of rotation, obtain the sum of the products (which sum is termed the "moment of inertia"), and divide it by the total weight of the ship; the quotient (k^2) will be the square of the "radius of gyration" for the ship when turning about the assumed axis. If the whole weight were concentrated at the distance k from the axis of rotation, the moment of the accelerating forces and the moment of inertia would then be the same as the aggregate moment of the accelerating forces acting upon each particle of lading and structure in its proper place.

It will be obvious from this attempt at a popular explanation of established dynamical principles why we cannot assume that a ship in *motion* resembles a simple pendulum suspended by the metacentre, and having all the accelerating forces acting through the centre of gravity. These accelerating forces developed during motion constitute, in fact, a new feature in the problem, not requiring consideration when there is no motion. For a position of rest, it is only necessary to determine the sum of the statical moments of the weight of each element about the centre of suspension, and this sum equals the moment of the total weight concentrated at the centre of gravity. But for motion, there is the further necessity of considering the moment of inertia, as well as the statical moment.

A ship rolling in still water does not oscillate about a *fixed axis*, corresponding to the centre of suspension (A) of the pendulum in Fig. 48; but still her motions are similar to those of the pendulum. At the extremity of a roll, when her inclination to the upright is a maximum, the moment of statical stability is also usually greater than that for any other angle within the arc of oscillation, and this is an unbalanced force, tending to restore the vessel to the upright. She therefore begins to move back, and at each instant during her progress towards the upright is subject to the action of a moment of statical

stability tending to make her move in the same direction, and consequently quickening her speed. But the moment of stability gradually decreases in amount, and at the upright is zero; the velocity reaching its maximum at that position. On the other side of the upright the statical stability opposes further inclination, and at every instant grows in magnitude; the result is a retardation of speed, and finally a termination of the motion of the ship at the other end of the roll at an inclination to the vertical equal to that from which she started. All this, be it observed, is on the hypothesis of *unresisted* rolling. As a matter of fact, with resistance in operation, it always acts as a retarding force, tending to extinguish the oscillations.

The position of the instantaneous axis about which a ship is turning at any moment, supposing her motion to be unresisted, and the displacement to remain constant during the motion, may be determined by means of a geometrical construction due to the late Canon Moseley. It may be most simply explained by reference to a cylindrical vessel with circular cross-section such as is shown in Fig. 49.

FIG. 49.

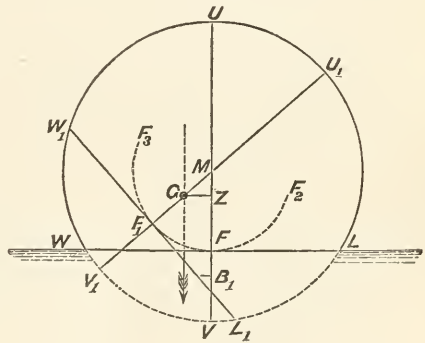

If a circle F_2FF_3 be described concentric with the circular section, and touching the water surface at F , this circle will touch the water-line corresponding to any other inclined position; for all the tangents to this circle cut off from the circular section a segment equal in area to WVL . The circle $F_3F_1F_2$ is termed the "curve of flotation," and a right cylinder described upon it as base would have this property: if the water surface is supposed to become rigid and perfectly smooth, and the cylinder of which F_3F_1F is a section, is supposed also to have a perfectly smooth surface, and to project before and abaft the ship, carrying her with it while the projecting ends roll upon the water surface, the conditions for unresisted rolling will be fulfilled. To determine the instantaneous centre, it is then only necessary to consider the simultaneous motions of the point of support, or "centre of flotation," F , and the centre of gravity G . The point F has its

instantaneous motion in a horizontal line; consequently it must be turning about some point in the vertical line FM . As to the motion of the centre of gravity, it must be noticed that, resistance being supposed non-existent, the only forces impressed upon the floating body are the weight and buoyancy, both of which act vertically; therefore the motion of translation of the centre of gravity must be vertical, and instantaneously G must be turning about some point in the horizontal line GZ . The point Z , where the two lines GZ and FM intersect, will, therefore, be the instantaneous centre about which the vessel turns.

This simple form of vessel always has the centre of buoyancy B , the centre of flotation F , and the metacentre M in the same vertical line, for any position it can occupy. An ordinary ship presents different conditions, as shown in Fig. 50; where the

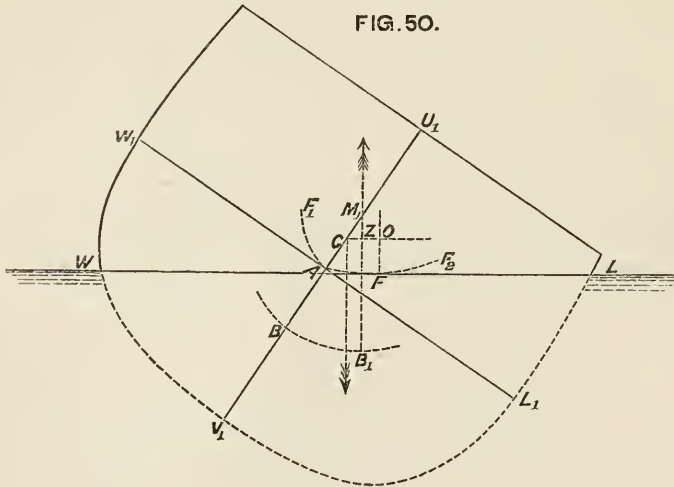

centre of flotation F does not lie on the vertical line B_1ZM_1 . Here, however, the same principles apply: G moves about some centre in the line GZO ; F about some centre in the vertical line FO ; the point of intersection O of these two lines fixes the instantaneous axis for the whole ship.

In war-ships the centre of gravity G ordinarily lies near to the water-line (W_1L_1 , Fig. 50) for the upright position; while for oscillations of 12 or 15 degrees on either side of the vertical, the centre of flotation F does not move far away from the middle-line A of the load-line section W_1L_1 . In other words, the common case for war vessels of ordinary form is that where the instantaneous axis passes through or very near to the centre of gravity.

Although the position of the instantaneous axis changes from instant to instant (as its name implies), it is not productive of any serious error in most cases to regard the ship as rolling about a fixed axis passing through the centre of gravity. In theoretical investigations no such assumption is necessary, because the principle known in dynamics as the "conservation of the motions of translation and rotation" then becomes applicable. The motion of *translation* of the centre of gravity is considered separately from any motion of *rotation*; this latter motion being then supposed to take place about an axis passing through the centre of gravity. By this means the "period" of an oscillation in still water can be very closely approximated to, although there is no fixed axis of rotation.

It may be interesting to show how the metacentre moves during unresisted rolling, instead of being fixed in space, as is often supposed. Taking once more the cylindrical vessel of circular cross-section, we have a case where the metacentre is fixed *in the vessel*, but moves *in space* as the vessel rolls. In Fig. 51 the darker circle represents the vessel in her upright position; the lighter one shows her position at the extremity of the roll. The centre of gravity G moves *vertically*, as explained above, and during the roll rises from G to G_1 , the corresponding position of the metacentre being M_1 . As the ship rolls therefore, the metacentre sways to and fro horizontally; but in less simple forms it would neither be fixed in the vessel nor have so simple a motion.

FIG. 51.

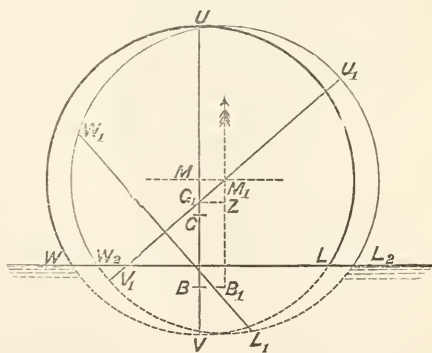

Summing up the preceding remarks on unresisted rolling, it appears that the active agent in producing the motion, after the vessel has once been inclined and then set free, is the moment of statical stability; and that the moment of inertia about a longitudinal axis passing through the centre of gravity is also of great importance. Mathematical investigation leads to the following expression for the period of oscillation of a ship:—

- Let k = her radius of gyration (in feet),
 m = metacentric height (GM) (in feet),
 T = period in seconds for a single roll.

$$\text{Then } T = \pi \sqrt{\frac{k^2}{gm}} = 3.1416 \sqrt{\frac{k^2}{gm}},$$

where g (measuring force of gravity) = $32\frac{1}{2}$ feet (nearly) per second. This may be written,

$$T = .554 \sqrt{\frac{k^2}{m}}.$$

A fair approximation to the still-water, or "natural" period of oscillation for a new ship can be made by means of this equation. The metacentric height would be determined for a war-ship as one of the particulars of the design; and the distribution of the weights would be known, so that the moment of inertia could be calculated about the assumed axis of rotation passing through the centre of gravity. This latter calculation is very laborious, the weight of each part of the structure and lading having to be multiplied by the square of its distance from the axis; but with care it can be performed with a close approach to accuracy. Calculations of this kind are rarely made, except in connection with novel types of ships, for which thorough investigations are needed in order to be assured of their safety and seaworthiness. As examples of close estimates of natural periods we may refer to the *Devastation* and a monitor of the American type, which were under the consideration of the Admiralty committee on designs for war-ships. It was estimated that the *Devastation* would have a period of about 7 seconds; the actual period obtained by experiment was $6\frac{3}{4}$ seconds. The estimated period for the American monitor was $2\frac{1}{2}$ seconds; the actual period, $2\frac{7}{10}$ seconds. The formula given for the period supposes the rolling to be unresisted; but the influence of resistance is much more marked in the extinction of oscillations than it is in affecting the period of oscillation, and this accounts for the close agreement of estimates made from the formula with the results of experiments. This statement may be illustrated by reference to experiments made both in this country and in France. Mr. Froude discovered that the period of the *Greyhound* remained practically the same after exceedingly deep bilge-keels had been fitted, as it was without such keels. Similar results were obtained with a model of the *Devastation* (see page 163). MM. Risbec and De Benazé, of the French Navy, ascertained that the tug *Elorn*, which had a period of 2.18 seconds without bilge-keels, had that period increased only to 2.25 seconds by the addition of those keels. And yet in all these cases the effect of the keels in extinguishing the oscillations was most

marked. The *Elorn* was not merely set rolling in still water, but was also rolled (on specially contrived supports) in dry dock; when her natural period for *unresisted* rolling was found to be 2.03 seconds. This last experiment furthermore confirmed the practical accuracy of the calculation that had been made beforehand of the moment of inertia, and the natural period of this vessel.*

The preceding formula for the still-water period enables one to ascertain approximately the effect produced upon the period by changes in the distribution of the weights on board a ship. Such changes usually affect both the metacentric height and the moment of inertia, and their effects may be summarised as follows:—

Period is increased by—

- (1) Increase in the radius of gyration;
- (2) Decrease in the metacentric height.

Period is decreased by—

- (1) Decrease in the radius of gyration;
- (2) Increase in the metacentric height.

“Winging” weights—that is, moving them out from the middle line towards the sides—increases the moment of inertia and tends to lengthen the period. The converse is true when weights—such as guns—are run back from the sides towards the middle line. Raising weights also tends to decrease the moment of inertia, if the weights moved are kept below the centre of gravity; whereas if they are above that point, the corresponding change tends to increase the moment of inertia. But all such vertical motions of weights have an effect upon the position of the centre of gravity, altering the metacentric height, and affecting the moment of inertia by the change in the position of the axis about which it is estimated. It is therefore necessary to consider both these changes before deciding what may be their ultimate effect upon the period of rolling. The principles stated above will enable the reader to follow out for himself the effect of any supposed changes in the distribution of the weights, and it is not necessary to give more than one or two examples. A ship of 6000 tons weight has a metacentric height of 3 feet and a period of 7 seconds; a weight of 100 tons is raised from 15 feet below the centre of gravity to 15 feet above. In consequence of the

* For particulars of these valuable experiments see the *Memoire* presented by Messrs. Risbec and De Benazé to

the Academy of Sciences in 1873; this is reprinted in *Naval Science* for 1874 and 1875.

transfer of the weight, the centre of gravity will be raised, and we have

$$\text{Rise of centre of gravity} = \frac{100 \text{ tons} \times 30 \text{ feet}}{6000 \text{ tons}} = \frac{1}{2} \text{ foot.}$$

$$\text{New value of GM} = 3 - \frac{1}{2} = 2\frac{1}{2} \text{ feet.}$$

Originally, according to the formula for the period,

$$7 = .554 \sqrt{\frac{k^2}{3}},$$

$$k = \frac{7}{.554} \sqrt{3} = 22 \text{ (nearly).}$$

The rise in the centre of gravity slightly alters the position of the axis about which the ship is considered to revolve, and this produces a change in the moment of inertia; but the change is so small that it may be neglected.

Then, after the weights are moved, the period T will be given by the equation,

$$T = .554 \sqrt{\frac{k^2}{2\frac{1}{2}}}$$

$$\therefore \frac{T}{7} = \sqrt{\frac{3}{2.5}} = 1.1$$

$$\therefore T = 7 \times 1.1 = 7.7 \text{ seconds (nearly).}$$

The decrease of 6 inches in the metacentric height thus lengthens the period about 10 per cent.

As a second case, suppose weights amounting in the aggregate to 100 tons, placed at the height of the centre of gravity, to be "winged" 15 feet from the middle line; their motion being horizontal does not affect the position of the centre of gravity.* Then we have,

$$\begin{aligned} \text{Original moment of inertia} &= 6000 \times k^2, \\ \text{Additional moment of inertia} &= 100 \times 15^2 = 22500. \\ \therefore \text{New moment of inertia} &= 6000 \times k^2 + 22500. \\ (\text{New radius of gyration})^2 &= \frac{6000 \times k^2 + 22500}{6000} \\ &= k^2 + \frac{15}{4}. \end{aligned}$$

* The expressions for changes in the moment of inertia produced by winging weights not originally at the middle line, nor placed at the height of the centre of gravity, can be easily formed;

it is only necessary to determine for each position the actual distances of the weights from the axis passing through the centre of gravity.

Originally, 7 seconds = $\cdot 554 \sqrt{\frac{k^2}{3}}$ (1)

Now $T = \cdot 554 \sqrt{\frac{k^2 + \frac{15}{4}}{3}}$ (2)

Therefore $T = 7 \sqrt{1 + \frac{15}{4k^2}}$; also $k^2 = 475$

$\therefore T = 7 \sqrt{1 + \frac{15}{1900}} = 7 \times 1\cdot 004$
 $= 7\cdot 028$ seconds.

This alteration in period is very slight, as compared with that produced by the supposed transfer of weight in a vertical sense, and furnishes an illustration of the much greater changes rendered possible by alterations of metacentric heights than by changes in the moments of inertia.

It is important to remark that in the mathematical investigation upon which the formula for the period of oscillation is based, it is assumed that there is no sensible difference between the time occupied by the ship in swinging through large or small arcs. Within a range of, say, 12 or 15 degrees on either side of the vertical—for which range the metacentric method of estimating the stability gives fairly accurate results—this condition has been proved by direct experiment to be fulfilled very nearly in vessels of ordinary form and high free-board. For example, the *Sultan* was rolled in still water until an extreme inclination of nearly 15 degrees on either side of the upright was reached, and then allowed to come to rest, the observations being continued until the extreme inclination attained was only 2 degrees; but the period of rolling through the arc of 30 degrees was practically identical with that for the very small arc of 4 degrees. This noteworthy fact is usually expressed by the statement that the rolling of ordinary ships is *isochronous* within the limits named above.

For larger angles of oscillation such ships would probably have a somewhat longer period than for the small oscillations, and it is possible to approximate to this increase.* But as yet direct experiment has not been applied to determine the actual periods when high-sided ships swing to 20 or 30 degrees on either side of the vertical; and the case is one which can be best dealt

* See a Paper contributed by Mr. W. John and the Author to the *Transactions* of the Institution of Naval Architects for 1871; see also page 229.

with by means of model experiments in the manner described on page 153. Vessels of low freeboard or exceptional form may not be isochronous through arcs of oscillation so large as those named for ordinary vessels; and the reasons for this difference will be understood from the remarks made hereafter. For unresisted rolling the theoretical condition for isochronism may be very simply stated:—Within the limits of inclination to the vertical, for which the statical righting moment varies directly as the angle of inclination, the rolling of a vessel will be isochronous. In other words, if the curve of stability is practically a straight line for a certain distance out from the upright, the rolling will be isochronous within the limits of inclination fixed by that distance.

Before concluding these remarks on the hypothesis of unresisted rolling, a brief exposition of the principles of *dynamical stability* must be attempted. On the assumption, that no account shall be taken of the effect of fluid resistance, dynamical stability may be defined as the “work” done in heeling the ship from her upright position to any angle of inclination; the amount of work done, of course, varying with the inclination. Work, it need hardly be said, is here used in its mechanical sense of a pressure overcome through a distance; for example, a ton raised one foot may be taken as our unit of work, and then to move 100 tons through a foot, or a ton through 100 feet, will require 100 units of work, or “foot-tons.” It has been shown how to estimate the moment of the couple for statical stability at a given angle; and if the vessel is gradually inclined beyond that angle, the forces inclining her must do work depending upon the righting couples corresponding to the successive

FIG. 54

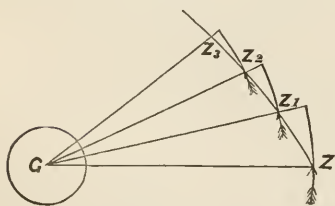

instantaneous inclinations, as well as to the ultimate angle attained. In short, it is easy to determine the dynamical stability, when the variations in statical stability are known, and the curve of stability has been constructed.

A simple illustration may make this clearly understood. A man is pushing at the end of a capstan bar (Z , in Fig. 54) with a force P , the centre of the capstan (G) is distant l feet from Z . Then the statical moment of the pressure P about G will equal $P \times l$, and

this exactly corresponds to the expression for the moment of statical stability ($D \times GZ$) obtained in the previous chapter. Now suppose the man to push the bar on through an angle A (circular measure); then—

$$\text{Distance the man walks} = l \times A;$$

$$\begin{aligned} \text{Work he does} &= \text{pressure} \times \text{distance through which it acts} \\ &= P \times l \times A = \text{statical moment} \times A. \end{aligned}$$

Next suppose that, as the man pushes the bar round, he moves inwards or outwards along it, varying the value of l from instant to instant; then we shall have a parallel case to that of the ship where the arm of the righting couple varies from angle to angle of inclination. The man walks for a *very small* distance from the first position (GZ , Fig. 54), pushing as before; then for that very small angle α , GZ will have practically the constant value l , and (as above)

$$\text{Work} = \text{statical moment (for position } GZ) \times \alpha.$$

By the time he has completed the angle A , he has moved in on the bar to the position Z_1 : let $GZ_1 = l_1$. Then, as he pushes with a constant force P , we must have for a very small angle α from the position GZ_1 —

$$\text{Work} = \text{statical moment (for position } GZ_1) \times \alpha.$$

Similarly, for any other position, the work for a very small angle beyond may be expressed in terms of the corresponding statical moment. And what is thus true of the capstan is equally true of a ship; the work for any small inclination α from a given position is given by—

$$\text{Work} = \text{statical moment of stability for that position} \times \alpha = \text{displacement} \times GZ \text{ (for that position)} \times \alpha.$$

Turning next to any curve of stability (say, to Fig. 43, page 118), we have a graphic delineation of the values of GZ for every inclination until the vessel becomes unstable. Supposing OP is taken to represent any assigned angle of inclination, and pm drawn very close to PN (the distance Pp corresponding to the very small angle α), the *area* of this little strip ($PNnp$) will graphically represent the product $GZ \times \alpha$. Consequently it follows that on the curve of stability for a ship, reckoning from the upright (O) to any angle of inclination (such as OP), the dynamical stability corresponding to that inclination is represented by the area (OPN) cut off by the ordinate corresponding to that inclination. The total area of the curve of stability therefore represents the total work to be done (excluding fluid resistance) in upsetting a ship.

Bearing this fact in mind, fresh force will be given to the remarks made in the previous chapter as to the comparative influence of beam and freeboard upon the form and range of curves of stability; and the contrasts exhibited between the curves of stability for various classes of ships given in that chapter, become still greater when the consideration of their relative total areas is added to that of their range. These, however, are matters upon which any one so desiring may proceed to independent investigation with the materials afforded; and no more will here be said respecting them.

We owe the term, and the first investigation for dynamical stability, to the late Canon Moseley, and his formula differs somewhat in appearance, though not in fact, from that given above. It may be well, therefore, to briefly indicate the chief steps in Canon Moseley's investigation. Starting from the principle that, apart from resistance, the only external forces impressed upon a ship rolling freely would be her weight and buoyancy, he remarked that the work done upon her in producing any inclination might be expressed in terms of the rise in space of the centre of gravity, where the weight might be supposed concentrated, and the fall of the centre of buoyancy, where the buoyancy might be supposed to be centred. Turning to Fig. 42, page 117, it will be seen that, when the ship is upright, B_1G is the vertical distance between these two centres, whereas in the inclined position their vertical distance becomes equal to BZ . In forming an estimate of the work done in producing an inclination, we are only concerned with the changes in the *relative* vertical positions of these two points; hence we may write, if V = volume of displacement (in cubic feet),

Work done in producing an inclination a } = $\frac{V}{35}$ ($BZ - B_1G$);
 (dynamical stability in foot-tons) . . . }

also,

$$BZ = RZ + BR = B_1G \cos a + BR;$$

and by the principle of the motion of the centre of buoyancy previously explained (see page 117),

$$BR = \frac{v}{V} (g_1 h_1 + g_2 h_2).$$

Substituting these values in the foregoing expression—

$$\begin{aligned} \text{Dynamical stability} &= \frac{V}{35} \left\{ \frac{v}{V} (g_1 h_1 + g_2 h_2) - B_1G (1 - \cos a) \right\} \\ &= \frac{1}{35} \left\{ v (g_1 h_1 + g_2 h_2) - V \cdot B_1G \text{ vers } a \right\}. \end{aligned}$$

This is Moseley's formula. But, since curves of stability have

been commonly constructed for ships, instead of using this formula, the dynamical stability has been much more easily calculated by the method of areas explained above, and its values for different inclinations are often represented by a curve.

Within the limits for which the rolling of a ship is isochronous, the curve of stability is a straight line, as explained above. Therefore for any angle a of inclination to the vertical within these limits

$$\begin{aligned} GZ &= GM \cdot a \\ \text{Statical Moment of Stability} &= \text{Displacement} \times GZ \\ &= \text{Displacement} \times GM \cdot a \end{aligned}$$

And evidently the area of the portion of the curve of stability cut off by the ordinate at the angle a will be given by the expression,

$$\begin{aligned} \text{Area of Triangle} &= \frac{1}{2} \times \text{base} \times \text{height} \\ &= \frac{1}{2} \times a \times GM \cdot a \\ &= \frac{1}{2} GM \times a^2. \end{aligned}$$

So that the amount of work done in heeling the ship from the upright to the angle a , excluding fluid resistance, will be given by the formula,

$$\begin{aligned} \text{Dynamical Stability} &= \text{Displacement} \times GM \times \frac{a^2}{2} \\ &= W \times m \times \frac{a^2}{2}. \end{aligned}$$

This formula is a very convenient one, much used in practice, and holding fairly well for ships of ordinary form up to angles of 10 or 15 degrees to the vertical.

Besides the motion of rotation about an axis passing through the centre of gravity of a ship rolling in still water, there is a motion of translation of the centre of gravity up and down a vertical line; and in the case of the cylindrical vessel (Fig. 51) we have seen how the metacentre moves when the volume of displacement is unchanged. But in few, if any, actual ships can this condition of constancy of displacement be accurately fulfilled at each instant; and with certain forms of cross-section, such as the Symondite type in Fig. 52, the departure from this condition is very considerable, giving rise to what are called "dipping oscillations" and "uneasy" rolling. Let it be assumed, for example, that the ship in Fig. 52 has rolled until W_1L_1 , which was her upright water-line, has come to the position shown, the motion probably occupying only 2 or 3 seconds. Then it may, and does, happen that the wedge immersed (LSL_1) will be in-

stantaneously greater than the wedge emerged (WSW_1); for, as already explained, during such a motion, if the roll does not exceed 15 degrees, the instantaneous centre will be nearly coincident with the centre of gravity, and this in war-ships of the Symondite type was near the load water-line. Suppose W_2L_2 to be the water-line at which the vessel would float if steadily held at the assumed inclination; for the instant, the buoyancy of the layer WW_2L_2L constitutes an unbalanced lifting force, which tends to set up a vertical motion in the ship. The ratio which the buoyancy of this layer bears to the total displacement of the ship determines whether this vertical motion will be considerable or not; and it is obvious that with the "pegtop" form of section in Fig. 52 the buoyancy of the layer may be great in proportion to the total buoyancy. Moreover, after motion begins,

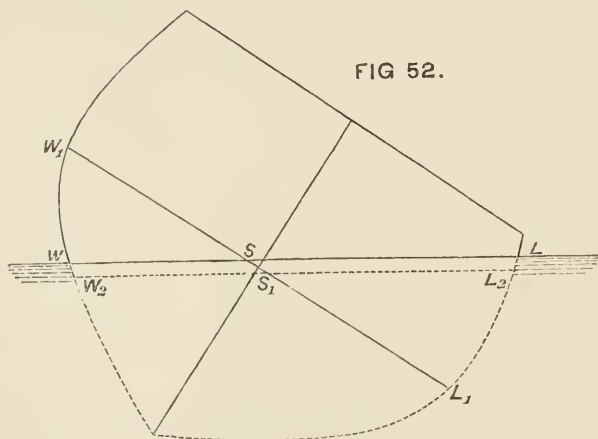

as the water-line W_2L_2 is moved upwards towards WL , there will still remain an unbalanced upward buoyancy, although one decreasing in amount, up to the instant that W_2L_2 reaches the water surface; and consequently, instead of stopping, the ship will be carried on beyond its position of rest, just as a pendulum inclined on one side of the vertical swings over to the other, past its position of rest in the vertical. Hence it follows that, if the vessel were conceived to be kept at the inclination shown, by forces that left her free to move vertically, she would "dip" upwards and downwards about her statical position of rest until the resistance of the water extinguished her oscillations.

Although ships rolling in still water are not thus held at a definite inclination, they are at each inclination subjected to

conditions of a similar character, and they have a period for their dipping oscillations which may be determined approximately, and the ratio of which to that of their rolling oscillations exercises an important influence upon the extent to which dipping proceeds. A single roll, even of a Symondite ship, may not produce much vertical motion, but a succession of rolls may; and the explanation of this fact was thus given by Professor Rankine:—"Each roll sets going a fresh series of dipping oscillations, and should the periodic time of rolling happen to be double, quadruple, or any even multiple of the periodic time of dipping, so that each roll coincides with the rising part of the previously existing dipping motion, the extent of the dipping motion may go on continually increasing to an amount limited only by the resistance of the water." In short, when these ratios of the periods of dipping and rolling obtain, the ship is in a condition similar to that of a pendulum which receives periodically a fresh impulse at the end of its swing; and it is a matter of common observation how such an impulse, although in itself not of great magnitude, may by its repeated applications in the manner described lead to considerable oscillations. Dipping motions have not, however, the practical importance of rolling motions, and therefore they will not be further discussed. In vessels of ordinary form these motions are not nearly so extensive as in vessels of the Symondite type, and the reasons for the difference will be obvious.

Turning attention to the effect of fluid resistance upon the rolling of a ship in still water, that resistance may be subdivided into three parts:—(1) Frictional resistance due to the rubbing of the water against the immersed portions of the ship, and particularly experienced by the amidship parts where the form is more or less cylindrical. (2) Direct or head resistance, similar to that experienced by a flat board pushed through the water, and chiefly developed against the keel, bilge-keels, deadwood, and flat or nearly flat surfaces lying near the extremities of the ship.* (3) Surface disturbance, which involves the creation of waves that move away from the ship, and have continually to be replaced by new-made waves, each creation involving, of course, a certain expenditure of energy, which must react upon the vessel, and be equivalent to a check upon her motion. The

* See also Chapter XI.

aggregate effect of these three parts of the fluid resistance displays itself in the gradual extinction of the oscillations when the ship rolls freely under the action of no external forces other than gravity and buoyancy; and if observations have been made of the rate at which extinction proceeds in any ship, or in a carefully constructed model of the ship (made on a reasonable scale) it is possible to infer from thence the total resistance for that ship, or for one identical with or very similar to her. But to estimate by direct calculation the value of the resistance for a ship of novel form, or for any ship independently of reference to rolling trials for similar ships or models, is not, in the present state of our knowledge, a trustworthy procedure. This difficulty in theoretical investigation arises chiefly from the doubtfulness surrounding any estimate of the "wave-making function" for an untried type. It is possible to approximate to the first two parts of the resistance, but the third, as yet, seems outside calculation. For example, when the character of the bottom of a ship is known—whether she is iron-bottomed, or copper-sheathed, or zinc-sheathed, and whether clean or dirty—it is possible to obtain the "coefficient of friction" for the known conditions; then knowing the area of the surface upon which friction operates, and the approximate speed with which the ship rolls, the total frictional resistance may be found within narrow limits of accuracy. Similarly, when the "coefficient of direct resistance" for the known speed has been determined by experiments on a board or plane surface, it may be applied to the total area of keel, bilge-keels, deadwood, &c., and so a good approximation made to the total "keel" or "direct" resistance. But the wave-making function cannot be similarly treated, and so it becomes most important to make rolling experiments in still water, in order that the true value of the resistance may be deduced from the observations. The importance of the deductions arises from the fact that fluid resistance has very much to do with controlling the maximum range of oscillation of a ship rolling in a seaway. This will be explained in Chapter VI.; for the present it is sufficient to remark that, if the rate of extinction of still-water oscillations is rapid, it may be assumed that the range of rolling at sea will be greatly limited by the action of the resistance; whereas, if the rate of extinction is slow, resistance will exercise comparatively little control over the behaviour of the ship at sea.

Rolling experiments in still water were recommended strongly by Bouguer in the *Traité du Navire* published in 1746, but their

performance has only become common within the last few years and they have been limited hitherto to war-ships. The late Mr. W. Froude, conducted the greater number of those made on ships of the Royal Navy, and to him we owe our most valuable information on the subject; a few experiments have been made by officers in command. In the French navy such experiments have been made systematically for some years, and many of the results obtained have been collected and published. The objects of these experiments are twofold: (1) to ascertain the period of oscillation of the ship; (2) to obtain the rate of extinction of the oscillations, when the vessel is left free to move and gradually comes to rest. Various means may be employed to produce the desired inclination, from which the vessel is to have her rolling motion observed. If she is small, she may be "hove-down," and, after reaching the required inclination, suddenly set free. But this is a process inapplicable to large ships, and the following is the plan usually adopted:—

A number of men are made to run across the deck, from side to side, their motions being regulated by some concerted signal, so that they may run out from the middle line to the side and back again, while the ship performs a half-oscillation. By this simple means even the largest ships may be made to accumulate motion very quickly, and to roll through considerable angles, the running of the men being so timed as never to retard, but always to accelerate, the rolling. For example, her Majesty's ship *Sultan* was made to roll to an angle of $14\frac{1}{2}$ degrees from the upright by the motion of her own crew of about six hundred men; while the *Devastation*, weighing over 9000 tons, was made to reach a heel exceeding 7 degrees by four hundred men running eighteen times across her deck. If the motions of the men are not well timed, similar results will not be obtained, and in some trials large angles of oscillation have not been secured, on account of non-compliance with this condition. When a sufficiently large range of oscillation has been obtained, the men are made to stand still, and the observations are commenced.

In order to determine the period for a single roll, careful note is taken of the times occupied by the ship in performing each of several successive single rolls; and in this way the fact has been established that vessels of ordinary form are practically isochronous in their rolling motions. Hence, in fixing the period for a ship, it is usual to observe how many oscillations (n , suppose) are made in a certain interval of time (T seconds, suppose); then the period = $T \div n$.

Careful observations are also made of the extreme angles of heel reached at the end of each oscillation; the difference between the successive values marking the rate of extinction. A vessel starting from an inclination of (say) 10 degrees to port only reaches an extreme heel of 9 degrees to starboard, and then rolls back to $8\frac{1}{4}$ degrees to port, gradually coming to rest. These observations are commonly continued until the arc of oscillation has diminished to 2 or 3 degrees. Mr. Froude and M. Bertin both devised beautiful automatic apparatus for recording the rolling motion of the ship in such a manner that the angle of inclination, at each instant of her motion, as well as her extreme angles of

FIG. 53.

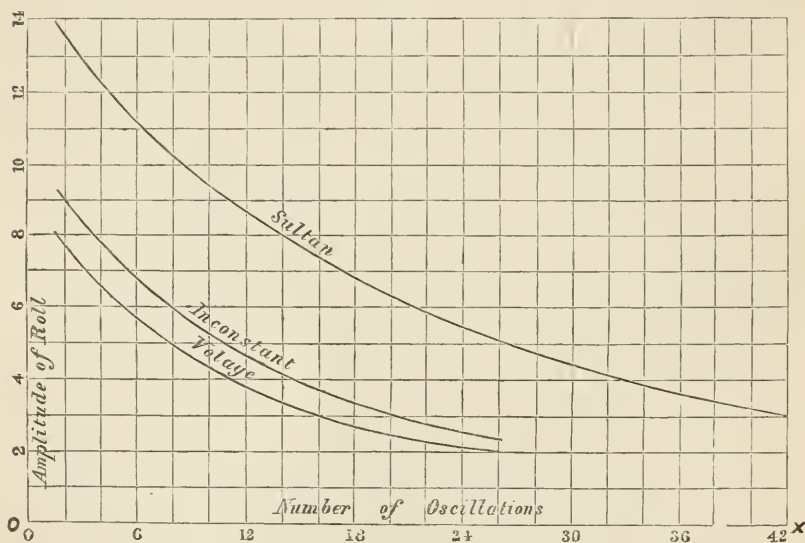

heel, can be traced, and the period also determined. But with the aid of the simplest apparatus it is possible to make all the observations needed, and in Chapter VII. the common plan of making the observations is described. The gradual degradation in the range of oscillation is represented by means of, what are termed, "curves of extinction"; examples of these curves, obtained from Mr. Froude's experiments, are given in Fig. 53, for her Majesty's ships *Sultan*, *Inconstant*, and *Volage*. A very brief explanation of the construction of these curves will suffice. On the base-line OX are set off equal spaces, each representing an oscillation; and since each oscillation is performed in the same period, each of these spaces also represents for each ship a certain number of

seconds. Any ordinate, drawn at right angles to OX, through the points marking these equal spaces, shows the extreme angle of heel reached at that particular oscillation; and the difference between any two ordinates so drawn shows the loss of range, or extinction of the rolling, in the corresponding number of oscillations. For example, after making twelve oscillations from the extreme angle ($13\frac{3}{4}$ degrees) where the record of observations began, the *Sultan* only reached an extreme angle of 8 degrees, the loss of range in that number of rolls being $5\frac{3}{4}$ degrees. Here the rate of extinction was slow, the vessel having a large moment of inertia, no keel, and only shallow bilge-keels, to assist the extremities in developing resistance to the motion. If there were deeper bilge-keels, the rate of extinction would be much more rapid.

Similar rolling experiments have been made with models; and a comparison of the curves of extinction obtained from models with those obtained from the full-sized ships represented by the models has proved that this simpler mode of procedure may be adopted if proper precautions are taken. One of the earliest and best experiments of this kind was made by the late Mr. Froude on a model of the *Devastation*, and when the ship herself was afterwards rolled it was found that her curve of extinction was practically identical with that obtained from the model. There are many obvious advantages in such model experiments. They can be made before the construction of a ship is begun; by means of them it is possible to test the influence of variations in form, or changes in bilge-keels, &c., upon the curve of extinction; and any critical conditions affecting the safety of a ship when damaged can be investigated. An excellent illustration of the value of these model experiments is found in the case of the *Inflexible*, to which reference will be made again.* In that case the model had its lineal dimensions one twenty-fourth those of the ship; it weighed nearly a ton, was weighted so as to float at the proper draught, had the centre of gravity in the estimated position, and had its moment of inertia so adjusted that it oscillated in still water in a period duly proportioned to the period estimated for the ship. Similar conditions are essential to these model experiments in all cases. The model for a new design simply represents the form, displacement, stability, and period

* For details see the Report of the Committee (*Parliamentary Paper*, No. 1917 of 1878).

embodied in the design and calculations; and for a completed ship represents those conditions as ascertained by observation and calculation. In all cases, moreover, the model must be made to a reasonable scale; and great care must be taken in recording its behaviour when the rolling experiments are in progress, minute differences for the model becoming exaggerated when the results are increased in scale so as to apply to ships.

In most cases still-water rolling experiments are limited to determinations of the period of oscillation and the curve of extinction; but in some cases they have been carried further, with the intention of determining completely the motion of the ship. The most thorough investigation of the kind with which we are acquainted is that conducted by MM. Risbec and De Benazé, mentioned on page 140. By means of special apparatus these gentlemen succeeded in obtaining an automatic record of the vertical and horizontal motions of the centre of gravity of the *Elorn*, as well as of her successive arcs of oscillation as her rolling was extinguished by resistance. Their subsequent analysis of these interesting records has advanced considerably our knowledge of some matters, and more particularly of those relating to the motion of the centre of gravity during rolling. When resistance comes into operation, the considerations respecting the instantaneous axis for unresisted rolling (stated on page 137) require considerable modification. The centre of gravity of the *Elorn*, for example, was found to have motions of translation in the horizontal as well as in the vertical sense, and this is doubtless true generally. Furthermore it appears that while the *Elorn* could not be said to perform her motions of rotation about any fixed axis, there was a point—termed by the experimentalists the *point tranquille*—which traversed the least path during the oscillatory motion of the ship. Their conclusions as to this point are summarised as follows:—In the *Elorn* “the *point tranquille* is “always situated between the centre of gravity and the water-line. “When there are no lateral keels and no ballast, it is near the “water-line; when there are no bilge-keels, but the centre of “gravity is lowered nearly a foot by ballast, it is very nearly “midway between that point and the water-line; lastly, when “there is no ballast but immersed lateral keels it approaches very “near to the centre of gravity, though still above that centre. “The position of the *point tranquille* may vary considerably in “different ships; more facts are needed in order to fix its ap- “proximate position in any case. . . . It is presumable that the “*point tranquille* rarely descends below the centre of gravity.”

These conclusions of the French experimentalists are in general accordance with experiments made by the late Mr. Froude in order to determine the "quiescent point," which was found to lie very close to the centre of gravity in several ships and models. A very simple procedure suffices to determine approximately the vertical position of the "quiescent point" when a ship is rolled in still water. Two or more pendulums, of very short periods, are hung at different heights in the ship; as she reaches successive angles of extreme inclination to the vertical the indications of these pendulums are noted, and the true inclinations of the ship are simultaneously ascertained. From this data, by means of the formula for the error of a pendulum given in Chapter VII., the vertical position of the "quiescent point" may be ascertained with sufficiently close approach to accuracy. Attempts have been made to frame mathematical expressions for the determination of the position of the instantaneous axis of rotation at any period of the rolling motion; but these investigations have little practical importance; and in estimates for the natural periods of ships, it is usual, as previously remarked, to assume that the axis of rotation passes through the centre of gravity.

Rolling experiments have now been made on most classes of war-ships, and their natural or still-water periods have been determined. It may be interesting to summarise the facts. For gun-vessels, gun-boats and small craft, the period for a single roll is from 2 to 3 seconds; these short periods being due to the small radii of gyration consequent upon the small dimensions, and to the necessity for securing a good "metacentric height." For despatch-vessels, sloops, &c., below the size of corvettes, periods of from 3 to $4\frac{1}{2}$ seconds are common; and 4 seconds is a good average. Unarmoured corvettes and frigates, possessing both sail and steam power, are found to occupy from 5 to 6 seconds in a single roll, but some of the modern types of swift steamers have periods of 8 seconds, their metacentric heights being less than those of earlier types. Turning to armoured ships, the shortest periods yet observed are found in coast-defence vessels of shallow draught, great proportionate beam, and large metacentric heights. An American monitor, for example, was found to have a period of 2.7 seconds only, and some of the French floating batteries have periods of 3 to 4 seconds. The French *Gloire*, the English converted ironclads of the *Caledonia* class, and other types of second-class ships have periods of 5 to 6 seconds. The *Inflexible*, notwithstanding her large dimensions and considerable moment of inertia, has a

period of $5\frac{1}{2}$ seconds only, due to her great metacentric height. The *Devastation* of the Royal Navy has a period of $6\frac{3}{4}$ seconds; and other first-class rigged ships have periods of 7 to $8\frac{1}{2}$ seconds. The *Sultan* is an example of small metacentric height and large radius of gyration; her period is 8.8 seconds. The *Suffren* of the French Navy is less stiff than the *Sultan* and has a period rather exceeding 10 seconds. This is the longest period for a single roll of which we have any knowledge; and it is to be observed that, in manœuvring in smooth water, the small initial stability of this class is said to have caused some disadvantages, although in a seaway the vessels are remarkably steady.

For merchant ships exact information respecting the still-water periods seems entirely wanting. It will appear, moreover, from the remarks made previously (page 80) that there may be considerable variations in the period of any individual ship on different voyages, changes in the character and stowage of the cargoes affecting both the metacentric height and the moment of inertia. Still-water rolling experiments for merchant ships have not found favour with owners hitherto, probably because of the belief that their performance might involve delays and difficulties; but such experiments might be very simply made, and would furnish valuable information respecting the good or bad stowage of the cargo carried on any voyage. Bouguer suggested this method of inquiry into the character of the stowage so long ago as 1746, and the counsel of the Institution of Naval Architects endorsed the suggestion in 1867. To give practical effect thereto the following course would be followed: Careful note would be taken of the behaviour of a ship on various voyages, and before starting a small series of rolling experiments would be made to determine the still-water period of the ship on each voyage. Hence would be discovered the mean period corresponding to the voyages on which the ship was proved to be well stowed by her good behaviour; and the endeavour in stowing the ship for further service would be to secure approximately the same period as she possessed on the successful voyages. This aim might not always be attained, nor would it always be possible to secure the period desired. But in every case, from such rolling experiments, supplemented perhaps by an inclining experiment, facts would be obtained enabling some idea to be formed of the probable behaviour of the ship at sea. Apart from such experiments there can be no check upon the character of the stowage; and in many cases where that character has been unsatisfactory the discovery has been made under the trying circumstances of

bad weather at sea when changes in stowage were practically impossible. That is a matter well deserving the consideration of shipowners.

The determination of the period for a ship is a matter of simple observation; but the investigations by which the value of the resistance is deduced from curves of extinction, like those in Fig. 53, are more difficult, involving mathematical processes which cannot be reproduced here. The principle upon which the investigations proceed may, however, be explained briefly. If a ship started from a certain extreme angle of inclination to the vertical, and her rolling was *unresisted*, she would attain an equal inclination on the other side of the vertical before coming to rest; but when she rolls under the action of resistance she comes to rest when she reaches a smaller inclination on the other side of the vertical. In other words the "loss of range" per oscillation represents the amount of "mechanical work" done by the resistance during that oscillation, which amount of work can be ascertained by calculating the *dynamical stability* corresponding to the loss of range. Suppose, for example, that a ship starts from an inclination of θ_1 on one side of the vertical, and reaches an inclination of θ_2 on the other side of the vertical. Then, using the approximate formula for the dynamical stability given on page 147, we have

$$\text{Dynamical Stability for inclination } \theta_1 = W \times m \times \frac{\theta_1^2}{2} .$$

$$\text{'' '' '' } \theta_2 = W \times m \times \frac{\theta_2^2}{2} .$$

$$\text{Hence, } \left. \begin{array}{l} \text{Dynamical Stability corresponding} \\ \text{to decrease of range} \end{array} \right\} = \frac{Wm}{2} (\theta_1^2 - \theta_2^2)$$

$$= \frac{W \cdot m}{2} (\theta_1 + \theta_2) (\theta_1 - \theta_2)$$

$$= \frac{W \cdot m}{2} \cdot \text{Arc of oscillation} \times \text{Loss of range.}$$

This last expression measures, as explained above, the work done by the fluid resistance during a single swing of the ship. Moreover it will be evident that when the curve of extinction for a ship has been determined experimentally, if any value of θ_1 is assumed, all the other quantities in the expression will be known. The value of the work done by the resistance can thus be determined, and some *data* obtained from which to infer approximately the laws which govern that resistance. In Chapter XI. the subject of fluid resistance is dealt with at length; and a few general remarks must suffice here. Fluid resistance to the motion of

a floating body, or of a body immersed in it, depends upon the rate of motion. When a flat surface is pushed forwards, the direct or head resistance, corresponding to the velocity, varies with the area of the surface, and with some power of the velocity, and so would also the frictional resistance experienced by a thin board drawn end-on through the water. The usual assumptions have been that for moderate speeds the resistance varied as the *square* of the velocity, that for very low speeds it varied nearly as the first power of the velocity, and for high speeds at a greater power than the square. For such speeds as are common in the rolling of ships, it is probable that the keel and frictional resistances vary nearly as the square of the angular velocity; and this is the law which French investigators agree in applying to the *total effect* of the resistance. Mr. Froude, however, whose experience and labours in this subject, as well as his numerous experiments, gave to his conclusions exceptional authority, was of opinion that the total resistance consists of two parts, one varying as the square of the angular velocity, the other as the first power. The former comprehends keel and frictional resistances; the latter is mainly represented by surface disturbance. It is only proper to add that by the analysis of curves of extinction published by French writers, as well as of curves obtained from his own experiments, Mr. Froude gave good reason for accepting his law of resistance.

Ships of ordinary form being isochronous for moderate angles of inclination on either side of the vertical, all their oscillations within limits, say, of 15 degrees on each side being performed in practically the same time, it follows that, as the range of oscillation increases, so will the mean angular velocity increase. Or, as we may say, the mean angular velocity varies as the arc of oscillation. Hence, it is possible to express the effect of the resistance (measured by the loss of range) per roll in terms of the arc of oscillation. For example, if 2θ be written instead of $\theta + \theta_2$, to express the arc of oscillation we may write,

$$\text{Loss of range} = a\theta + b\theta^2,$$

where a and b are constants determined from the still-water rolling experiments. The values of the constants, of course, vary with the character and form of the vessel, the depth of her bilge-keels, and the coefficient of friction. The rate of extinction of the still-water oscillations of any ship decreases as she approaches a state of rest. This is a matter of common observation and is fully borne out by the curves of extinction in

Fig. 53. From the foregoing remarks the explanation of this fact is readily obtained; the greater the range of oscillation, the quicker the motion, and the greater the resistance. Motion and the existence of the retarding force due to resistance cease simultaneously; resistance has, therefore, sometimes been termed a "passive" force, but it nevertheless exerts a very important and beneficial effect upon the behaviour of ships at sea.

The following are a few examples of the values of the constants *a* and *b*, determined by the late Mr. Froude, for ships of the Royal Navy: the angles θ being measured in degrees:

Ships.	<i>a</i> .	<i>b</i> .
<i>Sultan</i>	·0267	·0016
<i>Devastation</i>	·072	·015
<i>Inconstant</i>	·035	·0051
<i>Narcissus</i>	·037	·003
<i>Volage</i>	·028	·0073

The first two ships in this table are armoured: the remainder are unarmoured.

As an illustration of the use of the formula, suppose the *Inconstant* to be swinging through an arc of 16°. Here $\theta = 8^\circ$.

$$\text{Loss of range} = \cdot035 \times 8 + \cdot0051 \times 8^2 = \cdot61.$$

That is to say, the vessel would start from an inclination of about 8°·3 on one side of the vertical, and reach an inclination of about 7°·7 on the other side.

According to the French authorities the loss of range would be expressed very nearly by

$$\text{Loss of range} = N \cdot \theta^2$$

for arcs of oscillation exceeding 6°; which correspond to values of θ exceeding 3°. The following values of *N* are given on the

Ships.	<i>N</i> .
<i>Sultan</i> (English ironclad)	·0045
<i>Suffren</i> (French ironclad)	·0083
<i>Lagalissonière</i> (ditto)	·0075
<i>Inconstant</i> (English frigate)	·0123
<i>Volage</i> (English corvette)	·0141
<i>Annamite</i> (French transport)	·0170
<i>Hirondelle</i> (despatch vessel)	·015
<i>Elorn</i> (tug)	·016
<i>Navette</i> (tug)	·0109
<i>Crocodile</i> (gun-vessel: bilge-keels)	·033

authority of M. Bertin, of the French Navy, whose labours in this department of naval science have been most extensive and valuable.*

The preceding coefficients represent the rate of extinction of the rolling in ships having no headway. M. Bertin has conducted experiments for the purpose of ascertaining whether, when a ship is moving ahead and simultaneously rolling, the coefficients vary. The results for the *Navette* were as follows :

Speed of Ship.	Value of N.
Nil	·0109
4 knots.	·0123
8 knots.	·015

The explanation suggested is as follows:—When the ship is under-weigh she penetrates at each instant into water not yet disturbed, of which the whole inertia has to be overcome; whereas, when she has no headway and is rolled, similar conditions do not hold, and the inertia of the water is not so great. It is interesting to add that Mr. Froude found in his analyses of the rolling of the *Devastation* in a seaway that the actual resistance was somewhat greater than that inferred from the still-water experiments made under the usual conditions without headway.

The value or correctness of experimental data obtained by rolling ships is in no way affected by the divergence of opinion between English and French writers as to the mathematical treatment of curves of extinction and the mode of expressing the fluid resistance in terms of the angular velocity. After carefully considering the statements on both sides, and the published curves of extinction for French and English ships, we are strongly of opinion that the law proposed by the late Mr. Froude most closely accords with experimental data. In other words, the resistance appears to consist of two terms, one varying as the *first power* of the angular velocity, and the other varying as the *square*. The discussion of this question led Mr. Froude into a full investigation of the actual resistances of certain typical ships. Not content with obtaining the aggregate value of the resistances for these ships, he separated them into their component parts, assigning values to frictional and keel resist-

* See various Papers on "Waves and Rolling," contributed to *Naval Science*, 1873-1874, and to the *Revue Maritime*, 1877-1880.

ances, as well as to surface disturbance. In doing so, he was led to the conclusion that surface disturbance is by far the most important part of resistance, as the following figures will show.

Ships.	Frictional.	Keel, Bilge-keel, and Deadwood.	Total Re- sistance.	Surface Disturbance.
<i>Sultan</i> . . .	354	5036	20,000	14,610
<i>Inconstant</i> . .	140	4060	21,500	17,300
<i>Volage</i> . . .	96	2944	14,100	11,060
<i>Greyhound</i> . .	120	700	4,700	3,880

The frictional and bilge-keel resistances in this table were obtained by calculation from the drawings of the ship, making use of data as to coefficients for friction and for head resistance which had been previously obtained by independent experiments, and which may therefore be regarded as leading to thoroughly trustworthy results. The total resistance in each case was deduced from the curves of extinction obtained from still-water rolling experiments; and this also must be regarded as accurate. But it will be noticed that in no case does the sum of the frictional and keel resistances much exceed one-fourth of the total resistance, while it is much less than one-fourth in other cases. The consequence is that surface disturbance must be credited with the contribution of *three-fourths* or thereabouts of the total resistance. Waves are constantly being created as the vessel rolls, and are constantly moving away, and the mechanical work done in this way results in a reduction of the amplitude of successive oscillations. Very low waves, so low as to be almost imperceptible, owing to their great length in proportion to their height, would suffice to account even for this large proportionate effect. For example, Mr. Froude estimated that a wave 320 feet long and only $1\frac{1}{4}$ inch in height would fully account for all the work credited to surface disturbance in the fourth case of the preceding table. The lowness of these waves accounts for the fact that they may have escaped notice at the time of an experiment, and disposes of one argument that has been raised against the correctness of the foregoing statements. Moreover it is worth notice that the importance attributed by Mr. Froude to surface disturbance derives considerable support from experiments made on very special forms of ships. For example, in experimenting upon the model of the *Devastation*, it was found that, when the deck-edge amidships was considerably immersed before the model was set free to roll, the deck appeared to act like a very

powerful bilge-piece, rapidly extinguishing oscillations. MM. Risbec and De Benazé, of the French navy, also found by experiment that, when bilge-keels were moved high up the sides of a vessel, so that, as she rolled, the bilge-keels emerged from the water and entered it again abruptly, their effect became much greater than when they were more deeply immersed; as one would anticipate from the increased surface disturbance that must exist when the bilge-keels are so high on the sides. Experience with the low-freeboard American monitors furnishes further support to this view; immersion of the deck and the existence of projecting armour developing greatly increased resistance—a circumstance which undoubtedly tells much in favour of these vessels, and assists in preventing the accumulation of great rolling motions.

The figures in this table also indicate the large proportionate effect of "keel" resistance as compared with frictional resistance. It has already been explained that this direct or keel resistance is experienced by the comparatively flat surfaces of deadwoods, keels, bilge-keels, &c. Now it will be obvious that the underwater form of a ship has to be determined chiefly with reference to considerations of propulsion and stability; and that the naval architect can only pay attention to the influence which that form may have upon the resistance to rolling when he has satisfied these primary requirements. But while the shape of the hull proper is thus dealt with, the actual resistance to rolling may be considerably influenced by fitting such appendages as keels, bilge-keels, &c. The extent to which the influence of these appendages will be felt depends upon several conditions; such, for example, as their area, their position on the bottom, the period of the ship, her form, and her moment of inertia. Bilge-keels are the most important appendages in common use, and it may be of interest to examine into their mode of operation.

The evidence in favour of the use of bilge-keels is now considered unquestionable; but only a few years have elapsed since many eminent naval architects regarded bilge-keels with suspicion. Direct experiment and careful observation have mainly produced the change of opinion, showing that bilge-keels will increase the rapidity of the extinction of still-water oscillations, and limit the rolling of ships at sea. One very interesting series of experiments was made by the late Mr. Froude, for the information of the Committee on Designs for Ships of War (1871). A model of the *Devastation* was used for this purpose, and fitted with bilge-keels which, on the full-sized ship, would represent

the various depths given in the following table. The model was one-thirty-sixth of the full size of the ship, and was weighted so as to float at the proper water-line, to have its centre of gravity in the same relative position as that of the ship, and to oscillate in a period proportional to the period of the ship. In smooth water it was heeled to an angle of $8\frac{1}{2}$ degrees, and was then set free and allowed to oscillate until it came practically to rest, the number of oscillations and their period being observed. The following results were obtained:—

Model fitted with—	Number of Double Rolls before Model was practically at rest.	Period of Double Roll.
		Seconds.
1. No bilge-pieces	$31\frac{1}{2}$	1.77
2. A single 21-inch bilge-keel on each side	$12\frac{1}{2}$	1.9
3. " 36-inch " " "	8	1.9
4. Two 36-inch bilge-keels " "	$5\frac{3}{4}$	1.92
5. A single 72-inch bilge-keel " "	4	1.99

The great advantages resulting from the use of bilge-keels are obvious from this table. It will be noted also that the period of oscillation is changed but little as the resistance becomes increased. Similar results have been obtained in other cases. For example, in the *Elorn* M.M. Risbec and De Benazé found the rate of extinction was nearly doubled by fitting bilge-keels. M. Bertin found a yet larger increase in the rate of extinction in certain barges upon which he experimented; and estimated that in some small vessels with deep bilge-keels their effect represented more than 60 per cent. of the total resistance. In all these cases the vessels were small, their periods of oscillation short, and their moments of inertia comparatively small, all of which conditions tended to enhance the effect of the bilge-keels. This will be better understood, perhaps, if the formula is given by which an approximation can be made to the work done by a bilge-keel during the swing of a ship. Assuming the resistance to vary as the square of the angular velocity, and supposing r to be the *mean radius* of the bilge-keel from the axis of rotation (assumed to pass through the centre of gravity), then a mathematical investigation gives

$$\left. \begin{array}{l} \text{Work done in overcoming resist-} \\ \text{ance of bilge-keel during a} \\ \text{single swing} \end{array} \right\} = \left\{ \begin{array}{l} \text{Area of bilge-keel} \times r^3 \\ \times \frac{4}{3} \frac{\pi^2}{T^2} \times \theta^3 \times C_2; \end{array} \right.$$

where T = period for a single swing, and 2θ = arc of oscillation. The constant C_2 is determined by experiment. Mr. Froude adopted 1.6 lbs. per square foot with the velocity of 1 foot per second as a fair value for this coefficient C_2 ; and from his published examples we may select an illustration of the use of the formula. For the *Sultan*,

Area of bilge-keels	420 square feet
Value of r	25 feet
θ (circular measure)102
T (in seconds)	8.825

$$\begin{aligned} \therefore \text{Work of keels} &= 420 \times (25)^3 \times \frac{4}{3} \cdot \left(\frac{3 \cdot 1416}{8 \cdot 825}\right)^2 \times (.102)^3 \times 1.6 \text{ lbs.} \\ &= 1890 \text{ (nearly).} \end{aligned}$$

From the general form of the expression for the work done by bilge-keels, &c., it will be evident that their effect increases,

- (1) With increase in area;
- (2) With decrease in the period (T) of the ship;
- (3) With increase in the arc of oscillation.

Also, having regard to the formula for the period given on page 140, it will appear that the effect of such keels increases as the moment of inertia is diminished, or the metacentric height increased, both of which variations shorten the period of oscillation for a ship. The influence which can be exercised upon the period of a ship may be limited, for reasons previously stated; consequently the naval architect can work chiefly in the direction of increasing the area and power of bilge-keels, knowing that their influence cannot be otherwise than beneficial. Ships of the Royal Navy recently constructed have been furnished with much deeper bilge-keels than were formerly in use; the limit of depth in the larger vessels being fixed by the necessity for compliance with certain extreme dimensions in order that the vessels may be able to enter existing docks. The use of bilge-keels is also becoming common in certain classes of merchant steamers, but has not yet become general. One objection to their use has been shown to be fallacious; Mr. Froude having proved by towing trials made with the *Greyhound* sloop-of-war that only a very trifling increase in the resistance was caused by bilge-keels of exceptional depth, even when the vessel was subjected to great changes of trim.

The common practice is to fit one bilge-keel on each side, near the turn of the bilge. In some cases two keels have been fitted on each side; but there are objections to the arrangement. Two

shallow keels have much less power in extinguishing oscillations than a single deep keel of area equal to the combined areas of the other two (see experiments with *Devastation* model, page 163); and there is a difficulty, except in large ships, in placing two keels on each side, sufficiently clear of one another without the risk of emersing the upper keel during rolling. The reason for the comparative loss of power in two shallow keels is easily seen. As a bilge-keel swings to and fro with the ship it moves at varying velocities, and impresses accelerating motions on masses of water with which it comes in contact, these accelerations being the equivalents of the resistance. If there be two bilge-keels on each side, the water encountered by one will probably have been set in motion by the other keel, and consequently their combined resistance is less than the sum of the resistances which they would experience if acting singly. On the other hand, the addition of a bilge-keel, instead of using a deeper single bilge-keel on each side, may be the only possible means of increasing resistance in some cases. As regards the emersion of bilge-keels it is only necessary to remark that more or less violent blows or shocks are received by such keels as they enter the water again; and even when no structural weakness results, the noise and tremor are unpleasant. The power of side-keels placed near the water-line is very great; for example, in the *Elorn* the effect of such keels was *one-third* greater than that of ordinary bilge-keels. But for the reasons given they are rarely used; and in cases where an overhanging armour-shelf a few feet below the water-line acted as a side-keel, it has been found desirable to "fill-in" under the shelf in order to diminish the shocks of the sea.

Another interesting case, having considerable practical importance, is that where, from damage to the skin or from some other cause, quantities of free-water enter the interior of a ship and influence her rolling. In the preceding chapter (page 105) an explanation has been given of the reduction in stiffness, or metacentric height, which may occur under these circumstances; and it will be obvious that this reduction must produce an increase in the period of oscillation, as compared with the period of the ship with sides intact. This change of period may be determined approximately from the formula given on page 140, when the metacentric heights for the two conditions are known; but a still more important contrast between those conditions is that relating to their curves of extinction, and these can be determined by experiment alone. When water in the interior of a ship does not completely fill the space containing it, but has a free surface and

can move from side to side as the ship rolls, it exercises a more or less powerful extinguishing effect upon the oscillations. For instance, if a ship containing free-water is heeled steadily to some angle, the surface of the contained water will be horizontal. Supposing the ship to be let go, she will move back towards the upright at a rate depending upon the initial inclination and her natural period (allowing for the presence of the water). At any instant before she reaches the upright, the contained water will be acted upon by the force of gravity and by the accelerations due to the motion of the ship, and will tend to place its surface normal to the resultant of these forces (see page 183). If gravity alone acted, the water-surface would tend to become horizontal; but it might never actually become so during the motion, because the rate at which the adjustment of the surface can proceed depends upon the virtual head of the water contained within her, whereas the motion of the ship proceeds at its own rate, and, as a rule, faster than the motion of the water-surface. Consequently, when the ship passes through the upright, the water-surface will not have become horizontal, but be still inclined towards that side of the ship which was initially lowest. In the other half of the swing, as the ship increases her inclination on the other side of the vertical, the action of gravity tends to reverse the motion of the water-surface, and thus to retard the motion of the ship. This is a very incomplete sketch of the actual behaviour of the contained water; and, in practice, its flow from side to side in a ship would often be hampered by the presence of cargo, stores, divisions, &c., in the hold, all of which considerations would tend to complicate an exact statement of the problem. For our present purpose it will suffice to state generally that the motions of the contained water lag behind those of the ship, and therefore check her oscillations. This view of the matter is confirmed by experience, and has been acted upon in the designs of special classes of ships. In central-citadel ships, for example, having considerable metacentric heights when intact, and comparatively short periods, "water-chambers" have been formed above the armour decks; into which free-water can be introduced when desired, for the purpose of increasing the resistance to rolling, and making the ships steadier in a seaway. The *Inflexible* is the first vessel thus fitted which has been completed, and the experience gained in her both by still-water rolling and by her behaviour at sea has been conclusive as to the remarkable extinctive effect of the contained water, even when its total weight did not much exceed one two-hundredth part of her weight. In Chapter VI. some facts are given

respecting her rolling during the passage to the Mediterranean in the autumn of 1881. The experimental inquiries of the *Inflexible* Committee also furnished remarkable evidence of the possible effects of free-water. From the results obtained with the model of that ship, the Committee gave the following facts. When the ship is fully laden, with sides intact, her metacentric height is $8\frac{1}{4}$ feet, her period for a single swing they assumed to be 4 to $4\frac{1}{4}$ seconds, and her curve of extinction is the upper curve in Fig. 54a. When the ends are riddled the metacentric height falls

FIG 54a

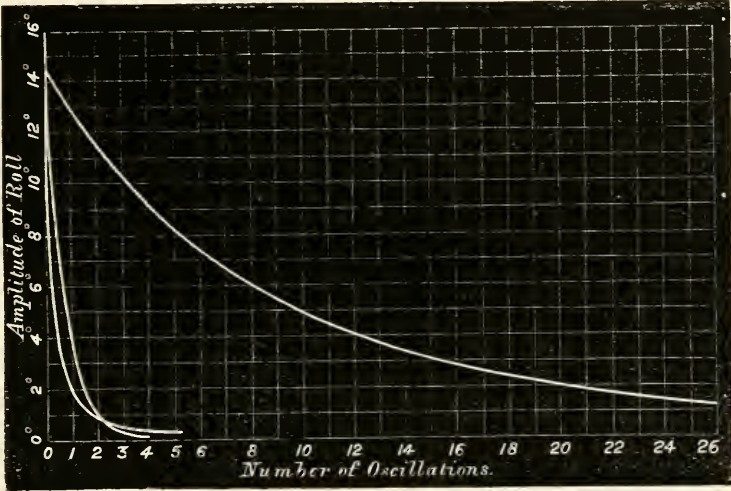

to 2 feet, the period is increased to 10 seconds, and the curve of extinction is the steepest curve. Supposing the very extreme condition termed “riddled and gutted” to be reached, the metacentric height is $\cdot 24$ foot, the period is 13 seconds, and the curve of extinction is the middle curve. Supposing the ship to be started with a roll having a range of 10° in each of these conditions, then the losses of range will furnish a means of comparing the extinguishing effect of the resistance. These losses are given as follows:—

Condition of <i>Inflexible</i> .	Loss of Range.
Ship intact	1°
” ends riddled	7.8
” ends riddled and gutted	7.4

One other passage of the Report may be quoted before leaving this subject: “It is obvious from the tabulated statement that

“extinctive power possessed by internal free-water is capable of being increased or diminished largely by comparatively “small changes in depth.” Accepting this conclusion, it will be evident that in any case where free-water is employed as a means of increasing steadiness, experiments must be had recourse to in order to decide upon the quantity of water to be admitted, and its depth.

Before concluding this chapter it will be desirable to explain briefly the practical use made of the theory of dynamical stability (explained on page 144), in comparing the safety of ships under the action of *suddenly applied* forces, such as gusts or squalls of wind. These do not, it is true, commonly occur under the condition of smooth water that is assumed throughout the present discussion; but it is convenient to separately consider their effect, and to deal with the action of the waves independently, for which purpose it is necessary to suppose the water still, while the wind acts on the ship.

Roughly speaking, it may be said that a force of wind which, steadily and continuously applied, will heel a ship of ordinary form to a certain angle will, if it strikes her suddenly when she is upright and at rest, drive her over to about twice that inclination, or in some cases further still. A parallel case is that of a spiral spring; if a weight be suddenly brought to bear upon it, the extension will be about twice as great as that to which the same weight hanging steadily will stretch the spring. The explanation is simple. When the whole weight is suddenly brought to bear upon the spring, the resistance which the spring can offer at each instant, up to the time when its extension supplies a force equal to the weight, is always less than the weight; and this unbalanced force stores up work which carries the weight onwards, and about doubles the extension of the spring corresponding to that weight when at rest.

One point of difference, however, will become obvious between the cases of the ship and the spring. It has been virtually assumed that the vessel, with all sails set, has been becalmed, say by some headland, but, suddenly passing out of this shelter, she is struck by the wind, which heels her over and continues to blow steadily for some time after its sudden application. Now inclination of the ship at once reduces the moment of the wind-pressure on the sails. Turning to the section, Fig. 29, page 74, suppose P to be the pressure of the wind, acting horizontally

and athwartships, let h be the height of its line of action above that of the equal and opposite fluid resistance P . Then *initially* the inclining moment of the wind on the sails will be given by the equation,

$$\text{Moment of sail power} = P \times h.$$

But the ship begins to heel as soon as the wind pressure begins to act, and for an inclination a we should have approximately, if the ship were at rest,

$$\text{Moment of sail power} = P \times h \cos^2 a.$$

This law of decrease in the moment of the sails does not profess to be accurate, and is known to be very inaccurate for large angles of inclination; but it is generally accepted as sufficiently near the truth for practical purposes. It must be noted, however, that in this method no account is taken of the reduction of the effective pressure of the wind on the sails produced by their motion to leeward, so that the results obtained therefrom can be regarded only as very roughly approximate. This will be further explained hereafter (see also Chapter XII.).

An illustration of the use of this curve of $(\cosines)^2$, or "wind curve," is given in Fig. 55; it is marked WCDW. Two curves of stability (1 and 2), for the *Captain* and *Monarch* respectively, also appear in that diagram; but the ordinates represent statical moments of stability instead of simple GZ values, this arrangement being made in order that the comparison between the two ships may allow for their different displacements. It will be assumed that they have equal sail spread and moments of sail, so that one wind curve will serve for both ships. The force of wind is supposed sufficient to hold the *Captain* at a steady heel of nearly 10 degrees, and the *Monarch* at a slightly greater heel. No matter how far the vessels become inclined, if the wind continues to act upon them, the part of the areas of the curves lying between the wind curve and the base-line will be absorbed in counterbalancing the steady pressure of the wind. Hence only the areas lying above the wind curve are available to resist gusts or squalls; and these areas are therefore termed the "reserve dynamical stability." Supposing the reserve to be large, the ship is much safer than if it be small, and on reference to the diagram (Fig. 55) it will be seen how very small was the reserve in the *Captain* when compared with the *Monarch*. Lowness of freeboard associated with a moderate metacentric height contributed to give the ill-fated *Captain* a curve of stability of quite

a different character from that of any other ship of war carrying masts and sails. Prior to her loss our information respecting the curves of stability for various classes of ships was very meagre; but now that numerous and laborious investigations have been made, the very exceptional character of the *Captain* stands out clearly, as may be seen by reference to Figs. 47 and 47c. In comparing her with the *Monarch*, as in Fig. 55, we have taken

FIG 55.

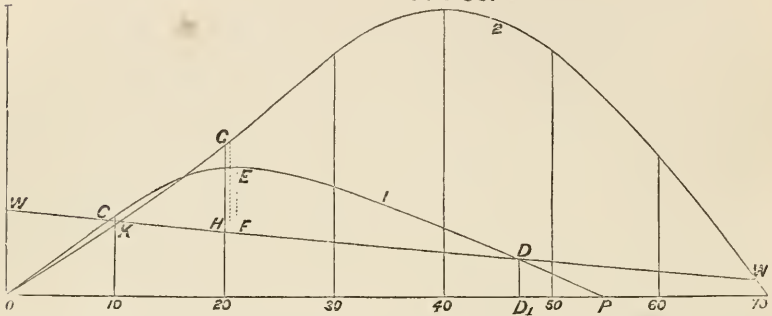

a rigged ironclad below the average as to the range of her stability, but even then the contrast is most remarkable. This will appear from the following statement, published, by authority, soon after the loss of the *Captain*, when many persons expressed fears, which were groundless, that a similar catastrophe might happen to the *Monarch* :—

	<i>Monarch.</i>	<i>Captain.</i>
Angle at which the edge of the deck is immersed	28°	14°
Amount of righting force in the above position (in foot-tons of moment)	12,542	5,600
Angle of maximum stability	40°	21°
Maximum righting force (in foot-tons of moment)	15,615	7,100
Angle at which the righting force becomes zero (range of stability)	69½°	54½°
Reserve of dynamical stability at an angle of heel of 14 degrees (in foot-tons of work) . . .	6,500	410

The last comparison is the most important as regards safety and from it one sees how small was the margin of safety of the *Captain* when sailing, as she is reported to have done on the day prior to her loss, at an angle of heel of 14 degrees. Adding to the wind pressure, the heave of the sea, and rolling oscillations, the reasons of the disaster are obvious.

Fig. 55 also furnishes an illustration of the method by which an approximation can be made to the maximum heel to which a

ship is driven by a squall of wind having a certain force if her motion is unresisted. Let WW be the wind curve as before; the point C, where WW intersects the curve of stability (1) for the *Captain*, determines the steady heel corresponding to the assumed force of wind. The ship is *upright* and at rest when struck, and between the upright and the angle of steady heel the moment of sails continuously exceeds the statical righting moment; hence there is an unbalanced force throughout this part of the motion, storing up work (represented by the area OWC) which is afterwards expended in carrying on the ship until an inclination (EF) is reached (about 20 degrees in this case) making the area (CEF) above the wind curve equal to the area WOC. The *Monarch* would be driven over to nearly an equal angle by the same squall; GH marks the inclination, the area GKH being equal to the area WOK.

A still more critical case is that where the ship has just completed a roll to windward when the squall strikes her. Accumulation of work then becomes far more serious; the righting moment and the moment of the sails act together as an unbalanced moment all the time that the vessel is moving back to the upright, the condition of things on the leeward side of the upright being similar to that already described. Fig. 56 illustrates this case

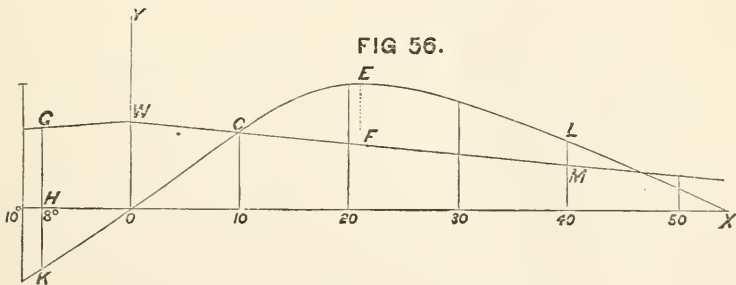

for the *Captain*. The extreme angle of roll to windward, before the squall strikes the ship, is indicated by the ordinate GHK (8 degrees); the ordinate LM marks the inclination (40 degrees) she must reach to leeward before the reserve of dynamical stability measured by the area CELMC can furnish the requisite amount of work to destroy the motion due to the accumulated work of roll and wind measured by the equal area GKOCWG.* This

* The wind curve is the same as in Fig. 55, the corresponding angle of steady heel being nearly 10 degrees; this curve will obviously be symmetrical about the upright position indicated by OY. On the windward

case shows that even in a calm sea a rigged ship of low freeboard or limited range of stability may run great risk of being capsized if struck by a squall, and illustrates the great advantages possessed by vessels having a large reserve of dynamical stability. Ships of the mastless type are less affected by the action of these suddenly applied squalls and gusts. Their broadsides do not offer sufficient surface to produce any sensible inclination in storms of ordinary severity. For instance, in the *Devastation* it is estimated that, with a storm of wind exerting a pressure of 100 lbs. per square foot, an inclination of only 5 degrees would be produced; but this pressure is about twice as great as that of a hurricane having a speed of 100 knots per hour. Hence a far more moderate range and area of the curves of stability is admissible for such vessels than is proper in rigged ships, and the Admiralty committee on designs recommended a range of 50 degrees as sufficient for such vessels, regarding them as safe even with a less range of stability.

It is necessary to remark that in the preceding estimate for the heeling effect of squalls no account has been taken of fluid resistance, which would assist in checking the motion, and bring a ship up at a less inclination than has been indicated. When the curve of extinction for a ship is known, and her "coefficients of resistance" have been deduced therefrom, it is possible to make the necessary corrections in the estimates for heeling: but this is not commonly done. The method to be followed will be understood from the explanations given (on page 157) of the manner in which the "work" done by the resistance during a single swing can be measured from the curve of extinction.

Moreover, it must be noted that when a ship is struck by a squall and moves away to leeward, her motion affects both the relative velocity and pressure of the wind on her sails, as well as the height of the centre of pressure. This matter has been mentioned above, and was fully discussed by the Author in a paper read before the Institution of Naval Architects in 1831; but the treatment is of too mathematical a character to be reproduced

side (to the *left*) of OY it will be noticed that the curve of stability is drawn *below* the base-line OX; the reason for so doing is that on the right-hand side (to leeward) ordinates measured *above* the axis tend to make the vessel move back to windward, so

that it is convenient to indicate the contrary tendency existing on the windward side (i.e. a tendency to drive the vessel back to leeward) by drawing the ordinates *below* the axis. No other feature in the diagram appears to require further explanation.

here. It may be interesting, however, to quote from that paper a few figures illustrating the very great influence which the action of fluid resistance, and the diminution in the moment of wind pressure produced by the angular motion of the sails, may have upon the angle to which a ship lurches when struck by a squall. Taking the unarmoured frigate *Endymion* of the Royal Navy, she is supposed to have reached an extreme inclination of 20 degrees to the windward side of the vertical and to be instantaneously at rest when a squall strikes her; then, by the method explained in Fig. 56, she would be driven over to 39 degrees on the leeward side of the vertical. All other conditions remaining unaltered, except that the effect of the fluid resistance is included, the extreme roll to leeward is found to be reduced from 39 degrees to 31 degrees. And, taking one step further, if allowance is made for the reduction in the effective pressure of the wind on the sails during the roll to leeward, the extreme inclination reached is 22 degrees, or 2 degrees only beyond the initial inclination to windward. The process of "graphic integration" by which these results are obtained is briefly explained in Chapter VI., and it would enable the problem to be solved completely, were it not for the fact that so little is known of the laws governing the pressure of wind on sails. But enough has been done to show how large is the margin of safety which is provided by the method described in Fig. 56.

Unfortunately, illustrations are not wanting of the possibility of sailing vessels being capsized in smooth water by the action of squalls. Two of the most recent are those of the American yacht *Mohawk*, and H.M.S. *Eurydice*.* The *Mohawk* was at anchor off Staten Island in 1876, with sail set, when the squall struck her. Being unprepared for bad weather, the heavy furniture and ballast shifted as the yacht heeled over; and, soon after her deck was immersed, the water poured into the cabin and cock-pit; so that all chance of righting was lost. It has been estimated that if the curve of stability of the *Mohawk* were calculated in the usual manner, on the assumption that no weights shifted and no water entered the hold, the angle of maximum stability would have been reached at 30 degrees, and the range would have been about 80 degrees. Under the circumstances described such a curve obviously did not represent the actual conditions of

* See reports of evidence given before the *Eurydice* Court Martial; also, as to *Mohawk*, see Mr. Dixon

Kemp's valuable work on *Yacht and Boat-sailing*.

stability of the vessel. In the case of the *Eurydice* also the actual curve of stability at the time the vessel was struck by the squall differed greatly from that made on the ordinary assumptions; and, as explained on page 126, the ports being open virtually reduced the vessel to the condition of a low freeboard rigged ship. The court martial recognised these facts in their report; and recorded their opinion that some of the lee-ports being open "materially conduced to the catastrophe." In their judgment also, these ports "having been open was justifiable and "usual under the state of the wind and weather up to the time of "the actual occurrence of the storm."

CHAPTER V.

DEEP-SEA WAVES.

MANY attempts have been made to construct a mathematical theory of wave motion, and thence to deduce the probable behaviour of ships at sea; and the diversity of these theories affords ample evidence, if evidence were needed, of the difficulties of the subject. To an ordinary observer perhaps no phenomena appear less susceptible of mathematical treatment than the rapid and constant changes witnessed in a seaway; but it is now generally agreed that the modern or trochoidal theory of wave motion fairly represents the phenomena, while preceding theories do not. Without attempting any account of the earlier theories, it is proposed in the present chapter to endeavour, in a simple manner, to explain the main features of the trochoidal theory for deep-sea waves.

Let it be supposed that, after a storm has subsided, a voyager in mid-ocean meets with a series of waves all of which are approximately of the same form and dimensions; these would constitute a single, or independent, series such as the trochoidal theory contemplates. For all practical purposes, such waves may be regarded as traversing an ocean of unlimited extent, where the depth, in proportion to the wave dimensions, is so great as to be virtually unlimited also; these are the conditions upon which the theory is based. The bottom is supposed to be so deep down that no disturbance produced by the passage of waves can reach it; and the regular succession of the waves requires the absence of boundaries to the space traversed. It is not supposed, however, that an ordinary seaway consists of such a regular single series of waves; on the contrary, more frequently than otherwise two or more series of waves exist simultaneously, over-riding one another, and causing a "confused sea," successive waves being of unequal size and varying form. But sometimes the conditions assumed

are fulfilled—a well-defined regular series of waves is met with; and from the investigation of their motions it is possible, as we shall see hereafter, to pass to the case of a confused sea. Nor is it supposed that only deep-sea waves are worthy of investigation; those occurring in shallower water also present notable features, but for our present purpose they are not nearly so important as ocean waves, since these latter so largely influence the behaviour of ships. It will be understood then that in what follows, unless the contrary is stated, we are dealing with a single series of regular deep-sea waves.

Any one observing such waves cannot fail to be struck with their apparently rapid advance, even when their dimensions are moderate. A wave 200 feet in length, from hollow to hollow, has a velocity of 19 knots per hour—faster than the fastest steamship—and such waves are of common occurrence. A wave 400 feet in length has a velocity of 27 knots per hour; and an Atlantic storm wave, 600 feet long, such as Dr. Scoresby observed, moves onward at the speed of 32 knots per hour. But it is most important to note that in all wave motion it is the *wave form* which travels at these high speeds, and not the particles of water. This assertion is borne out by careful observation and common experience. If a log of wood is dropped overboard from a ship past which waves are racing at great speed, it is well known that it is not swept away, as it must be if the particles of water had a rapid motion of advance, and as it would be on a tideway where the particles of water move onwards; but it simply sways backward and forward as successive waves pass.

Before explaining this distinction between the motions of the particles in the wave and the motion of the wave form, it will be well to illustrate the mode in which, according to the modern theory, the wave form or profile may be constructed. Fig. 57 will serve this purpose. Suppose QR to be a straight line, under which the large circle whose radius is OQ is made to roll. The length QR being made equal to the semi-circumference, the rolling circle will have completed half a revolution during its motion from Q to R; and if this length QR and the semi-circumference QR_1 are each divided into the same number of equal parts (numbered correspondingly 1, 2, 3, &c., in the diagram), then obviously, as the circle rolls, the points with corresponding numbers on the straight line and circle will come into contact successively, each with each. Next suppose a point P to be taken on the radius OR_1 of the rolling circle; this will be termed the “tracing point,” and as the circle rolls, the point P will trace a curve (a trochoid,

marked P, $a_2, b_2, c_2 \dots h_2$ in the diagram) which is the theoretical wave profile from hollow to crest, P marking the hollow and h_2 the crest. The trochoid may, therefore, be popularly described as the curve traced on a vertical wall by a marking-point fixed in one of the spokes of a wheel, when the wheel is made to run along a level piece of ground at the foot of the wall; but when thus described, it would be inverted from the position shown in Fig. 57.

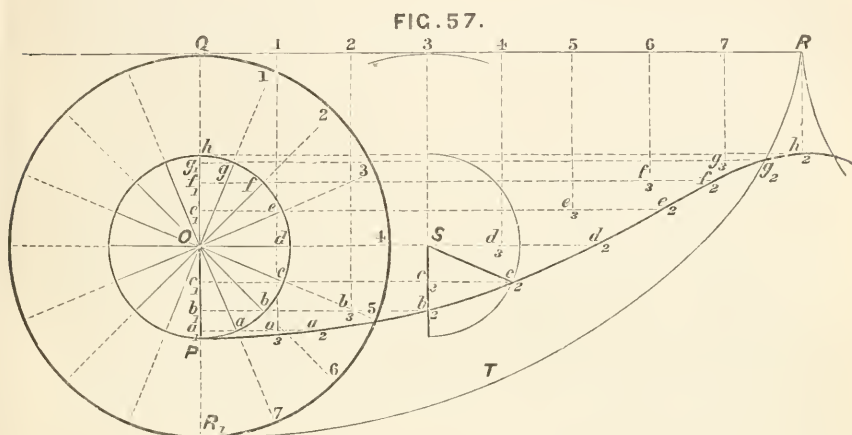

To determine a point on the trochoid is very simple. With O as centre and OP as radius describe the circle Pch . As the rolling circle advances, a point on its circumference (say 3) comes into contact with the corresponding point of the directrix-line QR; the centre of the circles must at that instant be (S) vertically below the point of contact (3), and the angle through which the circular disc and the tracing arm OP have both turned is given by QO3. The angle POe, on the original position of the circles, equals QO3; through S draw Sc_2 parallel to Oe, and make Sc_2 equal to Oe; then c_2 is a point on the trochoid. Or the same result may be reached by drawing ec_3 horizontal, finding its intersection (c_3) with the vertical line S3, and then making c_2c_3 equal to ec_1 . In algebraical language, this may be simply expressed. Take Q as the origin of co-ordinates, QR for axis of abscissæ (x).

Let radius OQ = a ,
 „ OP = b ,
 angle QO3 = θ ,
 and x, y co-ordinates of point c_2 on trochoid.

Then

$$\begin{aligned} x &= c_1 c_2 = c_1 c_3 + c_2 c_3 \\ &= a\theta + b \sin \theta; \\ y &= c_1 Q = OQ + Oc_1 \\ &= a + b \cos \theta. \end{aligned}$$

The tracing arm (OP) may, for wave motion, have any value not greater than the radius of the rolling circle (OQ). If OP equals OQ, and the tracing point lies on the circumference of the rolling circle, the curve traced is termed a *cycloid*; such a wave is on the point of breaking. The curve R₁TR, in Fig. 57, shows a cycloid, and it will be noticed that the crest is a sharp ridge or line (at R), while the hollow is a very flat curve.

A few definitions must now be given of terms that will be frequently used hereafter. The *length* of a wave is its measurement (in feet usually) from crest to crest, or hollow to hollow—QR in Fig. 57 would be the half-length. The *height* of a wave is reckoned (in feet usually) from hollow to crest; thus in Fig. 57, for the trochoidal wave, the height would be Ph; or twice the tracing arm. The *period* of a wave is the time (usually in seconds) its crest or hollow occupies in traversing a distance equal to its own length; and the velocity (in feet per second) will, of course, be obtained by finding the quotient of the length divided by the period, and would commonly be determined by noting the speed of advance of the wave crest.

Accepting the condition, that the profile of an ocean wave is a trochoid, the motion of the particles of water in the wave requires

FIG. 58.

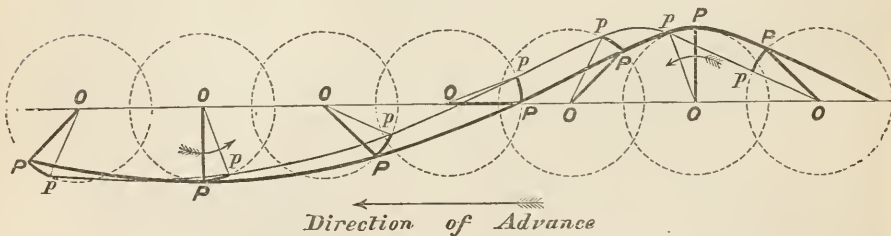

to be noticed, and it is here the explanation is found of the rapid advance of the wave form, while individual particles have little or no advance. The trochoidal theory teaches that every particle revolves with uniform speed in a circular orbit (situated in a vertical plane which is perpendicular to the wave ridge), and completes a revolution during the period in which the wave advances through its own length. In Fig. 58, suppose P, P, P, &c. to be particles on the upper surface, their orbits being the

equal circles shown: then, for this position of the wave, the radii of the orbits are indicated by OP , OP , &c. The arrow below the wave profile indicates that it is advancing from right to left; the short arrows on the circular orbits show that at the wave crest the particle is moving in the same direction as the wave is advancing in, while at the hollow the particle is moving in the opposite direction. It need hardly be stated again that for these surface particles the diameter of the orbits equals the height of the wave. Now suppose all the tracing arms OP , OP , &c. to turn through the equal angles POp , POp , &c.: then the points p , p , p , &c. must be corresponding positions of particles on the surface formerly situated at P , P , &c. The curve drawn through p , p , p , &c. will be a trochoid identical in form with P , P , P , &c., only it will have its crest and hollow further to the left; and this is a motion of advance in the wave form produced by simple revolution of the tracing arms and particles (P).^{*} The motion of the particles in the direction of advance is limited by the diameter of their orbits, and they sway to and fro about the centres of the orbits. Hence it becomes obvious why a log dropped overboard, as described above, does not travel away on the wave upon which it falls, but simply sways backward and forward. One other point respecting the orbital motion of the particles is noteworthy. This motion may be regarded at every instance as the resultant of two motions—one vertical, the other horizontal—except in four positions, viz.: (1) when the particle is on the wave crest; (2) when it is in the wave hollow; (3) when it is at mid-height on one side of its orbit; (4) when it is at the corresponding position on the other side. On the crest or hollow the particle instantaneously moves horizontally, and has no vertical motion. At mid-height it moves vertically, and has no horizontal motion. Its maximum horizontal velocity will be at the crest or hollow; its maximum vertical velocity at mid-height. Hence uniform motion along the circular orbit is accompanied by accelerations and retardations of the component velocities in the horizontal and vertical directions.

The particles which lie upon the trochoidal upper surface of the wave are situated in the level surface of the water when at rest.

* It is possible to construct a very simple apparatus by which the simultaneous revolution of a series of particles will produce the apparent motion

of advance; and in lectures delivered at the Royal Naval College such an apparatus was used by the Author.

The disturbance caused by the passage of the wave must extend far below the surface, affecting a great mass of water. But at some depth, supposing the depth of the sea to be very great, the disturbance will have practically ceased: that is to say, still,

FIG. 59.

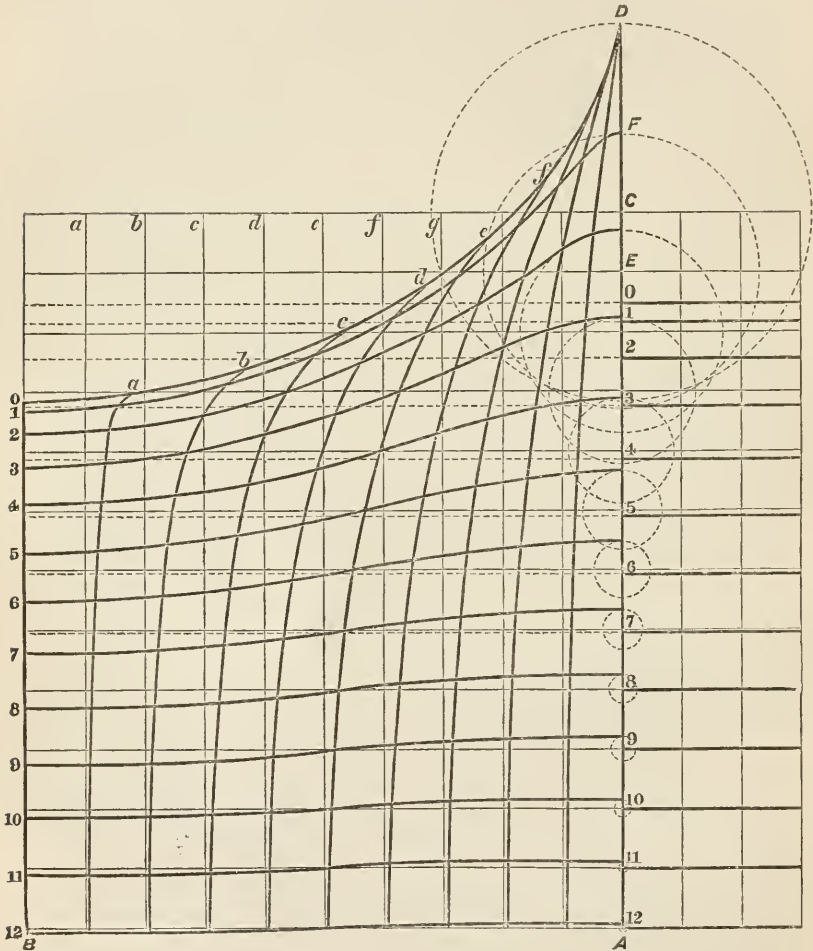

undisturbed water may be conceived as underlying the water forming the wave; and reckoning downwards from the surface, the extent of disturbance must decrease according to some law. The trochoidal theory expresses the law of decrease, and enables the whole of the internal structure of a wave to be illustrated in

the manner shown in Fig. 59.* On the right-hand side of the line AD the horizontal lines marked 0, 1, 2, 3, &c. show the positions in still water of a series of particles which during the wave transit assume the trochoidal forms numbered respectively 0, 1, 2, 3, &c. to the left of AD. For still water every unit of area in the same horizontal plane has to sustain the same pressure: hence a horizontal plane would be termed a surface (or subsurface of "equal pressure," when the water is at rest. As the wave passes, the trochoidal surface corresponding to that horizontal plane will continue to be a subsurface of equal pressure; and the particles lying between any two planes (say 6 and 7) in still water will, in the wave, be found lying between the corresponding trochoidal surfaces (6 and 7).

In Fig. 59, it will be noticed that the level of the still-water surface (0) is supposed changed to a *cycloidal* wave (0), the construction of which has already been explained; this is the limiting height the wave could reach without breaking. The half-length of the wave AB being called L, the radius (CD) of the orbits of the surface particles will be given by the equation,

$$CD = R = \frac{L}{\pi} = \frac{7}{22} L \text{ (nearly).}$$

All the trochoidal subsurfaces have the same length as the cycloidal surface, and consequently they are generated by the motion of a rolling circle of radius R; but their tracing arms—measuring half the heights from hollow to crest—rapidly decrease with the depth (as shown by the dotted circles), the trochoids becoming flatter and flatter in consequence. The crests and hollows of all the subsurfaces are vertically below the crest and hollow of the upper wave profile. The heights of these subsurfaces diminish in a geometrical progression, as the depth increases in arithmetical progression; and the following approximate rule is very nearly correct. The orbits and velocities of the particles of water are diminished by *one-half* for each additional depth below the mid-height of the surface wave equal to *one-ninth* of a wave length.† For example—

Depths in fractions of a wave length below the	}	0, $\frac{1}{9}$, $\frac{2}{9}$, $\frac{3}{9}$, $\frac{4}{9}$, &c.
mid-height of the surface wave		
Proportionate velocities and diameters		1, $\frac{1}{2}$, $\frac{1}{4}$, $\frac{1}{8}$, $\frac{1}{16}$, &c.

* This diagram we borrow from Mr. Froude's paper on "Wave Motion" in the *Transactions* of the Institution of Naval Architects for 1862; it was one

of the first constructed, and is therefore reproduced.

† See page 70 of *Shipbuilding, Theoretical and Practical*, edited by the

Take an ocean storm wave 600 feet long and 40 feet high from hollow to crest: at a depth of 200 feet below the surface ($\frac{2}{3}$ of length), the subsurface trochoid would have a height of about 5 feet; at a depth of 400 feet ($\frac{2}{3}$ of length) the height of the trochoid—measuring the diameter of the orbits of the particles there—would be about 7 or 8 inches only; and the curvature would be practically insensible on the length of 600 feet. This rule is sufficient for practical purposes, and we need not give the exact exponential formula expressing the variation in the radii of the orbits with the depths.

It will be noticed also in Fig. 59 that the centres of the tracing circles corresponding to any trochoidal surface lie above the still water-level of the corresponding horizontal plane. Take the horizontal plane (1), for instance. The height of the centre of the tracing circle for the corresponding trochoid (1) is marked E, EF being the radius; and the point E is some distance above the level of the horizontal line (1). Suppose r to be the radius of the orbits for the trochoid under consideration, and R the radius of the rolling circle: then the centre (E) of the tracing circle (i.e. the mid-height of the trochoid) will be above the level line (1) by a distance equal to $r^2 \div 2R$. Now R is known when the length of the wave is known: also r is given for any depth by the above approximate rule. Consequently, the reader has in his hands the means of drawing the series of trochoidal subsurfaces for any wave that may be chosen.

Columns of particles which are vertical in still water become curved during the wave passage; in Fig. 59, a series of such vertical lines is drawn (see the *fine* lines $a, b, c, d, \&c.$); during the wave transit these lines assume the positions shown by the *strong* lines ($a, b, c, d, \&c.$) curving towards the wave crest at their upper ends, but still continuing to inclose between any two the same particles as were inclosed by the two corresponding lines in still water. The rectangular spaces inclosed by these vertical lines ($a, b, c, d, \&c.$) and the level lines (0, 1, 2, &c.) produced are changed during the motion into rhomboidal-shaped figures, but remain unchanged in area. Very often the motions of these originally vertical columns of particles have been compared to those occurring in a corn-field, where the stalks sway to and fro, and a wave form travels across the top of the growing corn. But while there are points of resemblance between the two cases, there

late Professor Rankine; who, with the late Mr. Froude, did much to develop

the trochoidal theory, originally propounded by Gerstner.

is also this important difference—the corn-stalks are of constant length, whereas the originally vertical columns become elongated in the neighbourhood of the wave crests, and shortened near the wave hollows.

These are the chief features in the internal structure of a trochoidal wave, and in the following chapter they will be again referred to in order to explain the action of waves upon ships. It is necessary, however, at once to draw attention to the fact that the conditions and direction of fluid pressure in a wave must differ greatly from those for still water. Each particle in the wave, moving at uniform speed in a circular orbit, will be subjected to the action of centrifugal force as well as the force of gravity; and the resultant of these two forces must be found in order to determine the direction and magnitude of the pressure on that particle. This may be simply done as shown in Fig. 60 for a surface particle in a wave. Let BED be the orbit of the particle; A its centre; and B the position of the particle in its orbit at any time. Join the centre of the orbit A with B ; then the centrifugal force acts along the radius AB , and the length AB may be supposed to represent it. Through A draw AC vertically, and make it equal to the radius (R) of the rolling circle; then it is known that AC will represent the force of gravity on the same scale as AB represents centrifugal force. Join BC , and it will represent in magnitude and direction the resultant of the two forces acting on the particle. Now it is an established property of a fluid that its free surface will place itself at right angles to the resultant force impressed upon it. For instance, take the simple case of a rectangular box (shown in

FIG 60.

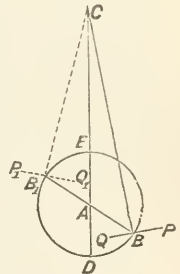

FIG 61.

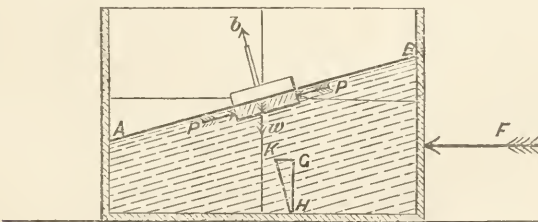

Fig. 61) containing water, which is made to move along a smooth horizontal plane by the continued application of a force F ; then

we shall have uniformly accelerated motion, equal increments of velocity being added in successive units of time.* In order to compare this force with that of gravity, if f is the velocity added per second of time, and W is the weight of the box and water, we should have,

$$\frac{F}{W} = \frac{f}{g} = \frac{f}{32\frac{1}{2}} \text{ (nearly).}$$

Now it is well known that under the assumed circumstances of motion the surface of the water in the box will no longer remain level, but will attain some definite slope such as AB in Fig. 61; and it is easy to ascertain the angle of slope. Through any point G draw GH vertical to represent the weight W , and GK horizontal to represent the force F ; join HK , and it will represent the resultant of the two forces, the water surface AB placing itself perpendicular to the line, on the principle mentioned above. The tangent of the angle which the surface AB makes with the horizon will equal the ratio of F to W .

Reverting to Fig. 60, the resultant pressure shown by BC must be normal to that part of the trochoidal surface PQ where the particle B is situated. Similarly, for the position B_1 , CB_1 will represent the resultant force; P_1Q_1 drawn perpendicularly to CB_1 , being a tangent to the trochoid at B_1 . Conversely, for any point on any trochoidal surface in a wave, the direction of the fluid pressure must lie along the *normal* to that surface. Hence it follows that wave motion involves constant changes in the magnitude and direction of the fluid pressure for any trochoidal surface; these changes of direction partaking of the character of a regular oscillation keeping time with the wave motion. At the wave hollow the fluid pressure acts along a vertical line; as its point of application proceeds along the curve, its direction becomes more and more inclined to the vertical, until it reaches a maximum inclination at the point of inflexion of the trochoid; thence onwards towards the crest the inclination of the normal pressure is constantly decreasing until at the crest it is once more vertical. If a small raft floats on the wave (as shown in Fig. 62), it will at every instant place its mast in the direction of the resultant fluid pressure, and in the diagram several positions of the raft are indicated to the left of the wave crest. These motions of the direction of the normal to the trochoid may be compared with those of a pendulum, performing an oscillation

* See remarks on this subject at page 135 of Chapter IV.

from an angle equal to the maximum inclination of the normal on one side of the vertical to an equal angle on the other side, and completing a single swing during a period equal to half the wave period.

FIG. 62.

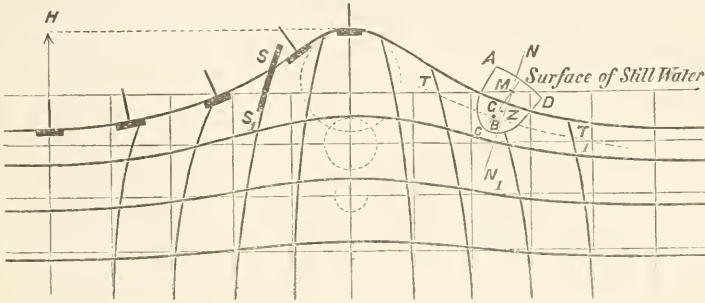

The maximum slope of the wave to the horizon occurs at a point somewhat nearer the crest than the hollow, but no great error is assumed in supposing it to be at mid-height in ocean waves of common occurrence where the radius of the tracing arm (or half-height of the wave) is about one-twentieth of the length. For this maximum slope, we have

$$\begin{aligned} \text{Sine of angle} &= \frac{\text{radius of tracing circle}}{\text{radius of rolling circle}} \\ &= \frac{\text{half-height of wave}}{\text{length of wave} \div 6.2832} \\ &= 3.1416 \times \frac{\text{height of wave}}{\text{length of wave}} \end{aligned}$$

For waves of ordinary steepness all practical purposes are served by writing the circular measure of the angle instead of the sine; hence ordinarily we may say,

$$\left. \begin{array}{l} \text{Approximate maximum wave slope} \\ \text{(in degrees)} \end{array} \right\} = 180^\circ \times \frac{\text{height of wave}}{\text{length of wave}}$$

Take, as an example, a wave for which the dimensions were actually determined in the Pacific, 180 feet long and 7 feet high:

$$\text{Maximum slope} = 180^\circ \times \frac{7}{180} = 7^\circ \text{ (nearly).}$$

The variation in the direction of the normal was in this case similar to an oscillation of a pendulum swinging 7 degrees on either side of the vertical once in every half-period of the wave

—some 3 seconds. These constant and rapid variations in the direction of the fluid pressure in wave water constitute the chief distinction between it and still water, where the resultant pressure on any floating body always acts in one direction, viz. the vertical.

But it is also necessary to notice that in wave water the *intensity* as well as the direction of the fluid pressure varies from point to point. Reverting to Fig. 60, and remembering that lines such as BC represent the pressure in magnitude as well as direction, we can at once compare the extremes of the variation in intensity. In the upper half of the orbit of a particle, centrifugal force acts *against* gravity, and reduces the weight of the particle; this reduction reaches a maximum at the wave crest, when the resultant is represented by $CE = (R - r)$. In the lower half of the orbit, gravity and centrifugal force act together, producing a virtual increase in the weight of each particle; the maximum increase being at the wave hollow, where the resultant is represented by $CD = (R + r)$. If a little float accompanies the wave motion, it may be treated as if it were a particle in the wave, and its apparent weight will undergo similar variations. In a ship, heaving up and down on waves very large as compared with herself, the same kind of variations will occur, though perhaps not to the same extent as in the little float. Actual observation shows this to be true. Captain Mottez, of the French navy, reports that on long waves about 26 feet high the apparent weights of a frigate at hollow and crest had the ratio of 12 to 8. According to the preceding rules we must then have,

$$\frac{R - r}{R + r} = \frac{8}{12},$$

$$\frac{2R}{2r} = \frac{20}{4},$$

$$R = 5r = 5 \times 13 = 65 \text{ feet.}$$

Length of waves (by theory) $= 2\pi R = 6.28 \times 65 = 408$ feet.

This, in proportion to the height recorded, is not an unreasonable length; but, unfortunately, Captain Mottez does not appear to have completed the information required, by measuring the actual length of the waves. The important fact he proved, however, is one that theory had predicted, viz. that the heaving motion of the waves may produce a virtual variation in the weight of a ship equivalent to an increase or decrease of one-fourth or one-fifth, when the proportions of the height and length of the waves are those common at sea.

Instead of the raft in Fig. 62, if the motions of a loaded pole or plank on-end (such as SS₁), be traced, it will be found that it tends to follow the originally vertical lines, and to roll always toward the crest as they do. Here again the motion partakes of the nature of an oscillation of fixed range performed in half the wave period, the pole being upright at the hollow and crest.

A ship differs from both the raft and the pole; for she has both lateral and vertical extension into the subsurfaces of the wave, and cannot be considered to follow either the motion of the surface particles like the raft or of an originally vertical line of particles like the pole. This case will be discussed in the next chapter.

The trochoidal theory connects the periods and speeds of waves with their lengths alone, and fixes the limiting ratio of height to length in a cycloidal wave. The principal formulæ for lengths, speeds, and periods for trochoidal waves are as follows:—

- I. Length of wave (in feet) = $5.123 \times \text{square of period (in seconds)}$
 $= 5\frac{1}{3} \times \text{square of period (nearly)}$.
- II. Speed of wave (in feet per second) . . . } = $5.123 \times \text{period} = \sqrt{5.123 \times \text{length}}$
 $= 2\frac{1}{4} \sqrt{\text{length}}$ (nearly).
- III. Speed of wave (in knots per hour) . } = $3 \times \text{period}$ (roughly).
- IV. Period (in seconds) = $\sqrt{\frac{\text{length}}{5.123}} = \frac{4}{9} \sqrt{\text{length}}$ (nearly).
- V. Orbital velocity of particles on surface } = { speed of wave } $\times \frac{3.1416 \times \text{height of wave}}{\text{length of wave}}$
 $= 7\frac{1}{9} \times \frac{\text{height of wave}}{\sqrt{\text{length of wave}}}$ (nearly).

To illustrate these formulæ, we will take the case of a wave 400 feet long and 15 feet high. For it we obtain,

$$\text{Period} = \frac{4}{9} \sqrt{400} = 8\frac{8}{9} \text{ second.}$$

$$\begin{aligned} \text{Speed} &= \frac{9}{4} \sqrt{400} = 45 \text{ feet per second.} \\ &= 3 \times 8\frac{8}{9} = 26\frac{2}{3} \text{ knots per hour.} \end{aligned}$$

$$\text{Orbital velocity of surface particles } \left\{ = 7\frac{1}{9} \times \frac{15}{\sqrt{400}} = 5\frac{1}{3} \text{ feet per second.} \right.$$

It will be remarked that the orbital velocity of the particles is very small when compared with the speed of advance; and this is always the case. In formula V, if we substitute, as an average ratio for ocean waves of large size,

$$\text{Height} = \frac{1}{20} \times \text{length},$$

the expression becomes—

$$\begin{aligned} \text{Orbital velocity of surface particles} &= 7\frac{1}{9} \times \frac{\frac{1}{20} \times \text{length}}{\sqrt{\text{length}}} \\ &= 0.355 \sqrt{\text{length}}. \end{aligned}$$

Comparing this with Formula II. for speed of advance, it will be seen that the latter will be between six and seven times the orbital velocity.

The periods of waves are most easily observed, and the following table will be useful as giving the lengths and speeds of trochoidal waves for which the periods are known:—

Period. Seconds.	Length. Feet.	Speed of Advance.	
		Feet per Second.	Knots per Hour.
1	5.12	5.12	3.03
2	20.49	10.24	6.07
3	46.11	15.37	9.1
4	81.97	20.49	12.14
5	128.08	25.62	15.17
6	184.44	30.74	18.21
7	251.04	35.86	21.24
8	327.89	40.99	24.28
9	414.99	46.11	27.31
10	512.33	51.23	30.35
11	619.92	56.36	33.38
12	737.76	61.48	36.42
13	865.84	66.6	39.45
14	1004.17	71.73	42.49
15	1152.74	76.85	45.52
16	1311.56	81.97	48.56

As a mathematical theory, that for trochoidal waves is complete and satisfactory, under the conditions upon which it is based; but sea-water is not a *perfect fluid* such as the theory contemplates; in it there exists a certain amount of viscosity, and the particles must experience resistance in changing their relative positions. There is every reason to believe that the theory closely approximates to the phenomena of deep-sea waves, but it is very desirable that extensive and accurate observations of the dimensions and speeds of actual waves should be made, in order to test the theory, and determine the closeness of its approxima-

tion to truth. The recorded observations on waves are not so complete or numerous as to furnish the test required; and, by adding to them during their service at sea, naval officers will do much to advance one important branch of the science of naval architecture.

Systematic observations of ocean waves scarcely appear to have been attempted until within the last half-century. Amongst the earliest workers in this field were Dr. Scoresby, Mr. Walker, and Commodore Wilkes (United States navy); and of these the first named is justly the best known.* In 1847, Dr. Scoresby made a series of valuable observations on Atlantic storm-waves; and in 1856 he made a still more extensive series of observations during a voyage to Australia *viâ* the Cape of Good Hope, and a return voyage to England *viâ* Cape Horn. The records of wave-phenomena, published by Dr. Scoresby, constituted, until recently, the most valuable information on the subject; but during the last ten years very numerous and trustworthy observations have been made by officers of the Royal Navy, and by officers of the French navy. Of the French observers the most laborious and distinguished is Lieutenant Paris, who, during a voyage of more than two years (1867-70), observed and recorded several times each day the state of the sea and the force of the wind. He has been followed by other officers, whose labours have resulted in the accumulation of an unrivalled mass of facts respecting the lengths, periods, speeds, and heights of ocean waves. Much of this information has been published, and will repay careful study.† No similar publication has appeared of the results of observations of waves made by officers of the Royal Navy during the period above-named; but the regulations issued by the Lords Commissioners of the Admiralty provide for the frequent conduct of such observations, and an analysis of the records ought to yield valuable information.

* For the data obtained by Dr. Scoresby see the *Report* of the British Association for 1850, and his *Journal of a Voyage to Australia*. The results of Mr. Walker's observations will be found in the *Report* of the British Association for 1842; these observations were made at Plymouth. Commodore Wilkes' "Narrative of the United States Exploring Expedition" (1838-42) contains the details of his observations made to the south of Cape Horn.

† Lieutenant Paris' very able Memoir will be found in vol. xxxi. of the *Revue Maritime*. The most complete summary of the French observations with which we are acquainted is M. Antoine's *Des Lames de Haute Mer* (Paris, 1879). Much interesting information and valuable suggestion is to be found in M. Bertin's essay on the "Experimental Study of Waves," published in the *Transactions* of the Institution of Naval Architects for 1873.

From a scientific point of view, and as a test of the trochoidal theory, the observations made when a ship falls in with a single series of approximately regular waves are most valuable. More frequently observations have to be conducted in a confused sea, successive waves differing from one another in lengths, heights, and periods; and occasional waves occurring of exceptional size as compared with their neighbours. Careful notation of such phenomena would throw light upon the question of the superposition of series of waves, and explain many apparent discrepancies met with in simultaneous observations of waves made by ships sailing in company. It is, however, obviously essential to the value of all these observations that they should be conducted on correct methods, and be accompanied by full records of the attendant circumstances.

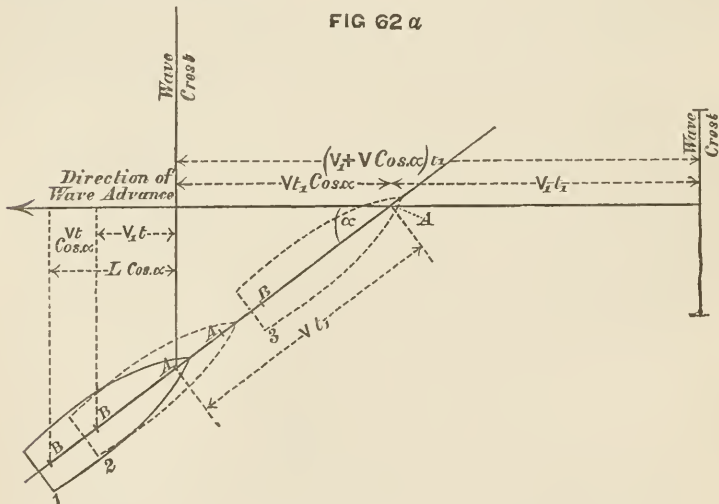

References.

1. Initial position of ship. 2. Her position at time t from beginning of observations. 3. Her position at time t_1 from ditto.

Supposing a single series of waves to be encountered, the *lengths* and *periods* of successive waves can be easily determined, if the speed of the ship and her course relatively to the line of advance of the waves are known. The method adopted by Dr. Scoresby and other early observers is still in use, and may be briefly described.*

Two observers (A and B Fig. 62a) are stationed as far apart as

* We here follow very closely the Memorandum prepared by the late Mr. Froude, and approved by the Admiralty for use in the Royal Navy.

possible, and at a known longitudinal distance from one another. At each station a pair of battens is erected so as to define, when used as sights, a pair of parallel lines at right angles to the ship's keel. The observer at the foremost station notes the instant of time when a wave crest crosses his line of sight; he also notes how long an interval elapses before the next wave crest passes that line. The second observer makes two similar notations for the respective crests. Comparing their records, the observers determine (1) the time (say t seconds) occupied by the wave crest in passing over the length (L feet) between their stations; (2) the time (say t_1 seconds) elapsing between the passage of the first and second crests across either line of sight: this time is termed the "apparent period" of the waves. Suppose the ship to be advancing at a speed of V feet per second *towards* the waves, her course making an angle of a degrees with that course which would place her end-on to the waves. Then, expressing the facts algebraically:—

$$\text{Apparent speed of wave (feet per second)} = \frac{L}{t}.$$

$$\text{Real speed of wave} \quad \quad \quad \quad \quad \quad = V_1 = \left(\frac{L}{t} - V\right) \cos a.$$

$$\begin{aligned} \text{Real length of wave (feet)} &= (V_1 + V \cos a) t_1 \\ &= L \cos a \cdot \frac{t_1}{t}. \end{aligned}$$

$$\text{Period of wave} = \frac{L \cos a}{V_1} \cdot \frac{t_1}{t} = \frac{L_1 \cdot t_1}{L - Vt}.$$

If the ship is supposed to be steaming *away* from the waves on the same course at the same speed, all that is necessary is to invert the sign of V in the foregoing equations.

As an example, take the following observations made by Dr. Scoresby during his voyage to Australia, in 1856. The *Royal Charter* was scudding directly before wind and sea, at a speed of 12 knots. An interval of 18 seconds elapsed between the passage of two successive wave crests across the observer's line of sight; and any single wave crest took 9 seconds to traverse a length of 320 feet. Here we have:—

$$\begin{aligned} a &= 0; \quad L = 320 \text{ feet}; \quad t_1 = 18 \text{ seconds}; \quad t = 9 \text{ seconds}; \\ &\quad V = 20 \cdot 25 \text{ feet per second.} \end{aligned}$$

Substituting in the foregoing equations,

$$\text{Real speed of waves} = V_1 = \left(\frac{320}{9} + 20 \cdot 25\right) = 55 \cdot 8 \text{ ft. per sec.}$$

$$\text{Real length of waves} = 320 \times \frac{18}{9} = 640 \text{ feet.}$$

$$\text{Real period of waves} = \frac{640}{55.8} = 11\frac{1}{2} \text{ seconds (nearly).}$$

From the foregoing remarks it will be obvious that the simplest method of observing the lengths and periods of waves can be applied when a ship is placed end-on to the waves and is stationary. The true period and true speed of the waves can then be obtained by direct observation, and the lengths estimated.

When ships are sailing in company a good estimate of the lengths of waves may be made by comparing the length of a ship with the distance from crest to crest of successive waves. Care must be taken, of course, to note the angle which the keel of the ship used as a measure of length makes with the line of advance of the waves; otherwise the apparent length of the wave may considerably exceed the true length.

Another method of measuring wave lengths consists in towing a log-line astern of a ship, and noting the length of line when a buoy attached to the after end floats on the wave crest next abaft that on which the stern of the ship momentarily floats. This was the method used by Commodore Wilkes of the United States navy in the observations of waves made by him south of Cape Horn in 1839; it has also been used in the Royal Navy. For its successful application a ship should be placed end-on to the waves, or allowance must be made for the departure of the log-line from that end-on position.

Wave heights are, in most cases, readily measured by the following simple method. When the ship is in the trough of the sea, and for an instant upright, the observer takes up a position such that the successive average wave ridges, as viewed by him from the trough, just reach the line of the horizon without obscuring it. The height of his eye above the water-level correctly measures the height of the wave. In making such observations it is desirable to select a position nearly amidships, so that the influence of pitching and 'scending may be diminished as much as possible; but if it becomes necessary to take stations near the bow or stern allowance must be made, in estimating the height of the eye above water, for the deeper immersion which may be caused at the instant by pitching or 'scending. Due allowance must also be made for changes of level occasioned by rolling or heeling, as well as for the fact that when a ship end-on to the waves is in the middle of the trough the curvature of the

wave hollow gives extra immersion to her ends, while the water surface amidships is somewhat below her natural water-line.

This method of estimating wave heights was used by Scoresby, and has been adopted by most of his successors. To measure very high waves the observer may have to ascend the rigging; while for waves of less height a station on one of the decks may suffice, or some temporary expedient devised for placing an observer near the water-level.

Other methods of measuring wave heights have been proposed, based upon the fact (mentioned at page 182) that at a considerable depth below the surface of a disturbed sea, practically still water may be found. Mr. Froude devised one of the best methods of this kind; the apparatus required being very simple and easily managed. It consisted of a light tapered spar of comparatively small diameter, graduated and marked in such a manner as enabled an observer to note with ease the rise and fall of the waves upon it. When in use this pole was "anchored" to the undisturbed water by means of a deep-sea line, to the lower end of which a light frame (see Fig. 63) was attached, this frame carrying a certain amount of ballast. The pole thus weighted stood upright, and performed extremely small vertical oscillations as the waves passed; consequently an observer on board a ship near the pole could note the heights and periods of waves with a close approach to accuracy. This method was applied by Mr. Froude in connection with his experiments with the model of the

FIG 63.

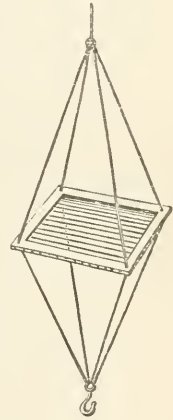

Devastation at Spithead (see Chapter VI.). It is particularly applicable to cases where waves of small height are to be measured, and where horizon observations are not easily made. For general use at sea it is scarcely likely to find favour; nor was it expected to do so by Mr. Froude. Any apparatus of this kind requires that the ship using it must be practically "hove-to" during the time occupied in putting the apparatus overboard, testing its adjustments, making the observations, and afterwards recovering it. On the other hand horizon observations, when practicable, can be made without interference with the progress of the ship.

Similar objections apply to the automatic "wave-tracer" constructed in 1866 by Admiral Paris of the French navy, and tried at Brest with considerable success. The design of this instrument was very simple. A light pole was prepared (similar to that used

by Mr. Froude) upon which to measure the rise and fall of the waves. This pole was of considerable length as compared with the heights of the waves to be measured, its cross-section was of small area; and it was ballasted with sheet lead in order that it might float upright, with a considerable portion of its length projecting above the surface of still water. No attempt was made to "anchor" the pole to the subjacent undisturbed water; and it consequently performed sensible, but small, vertical oscillations as the waves rose and fell upon it. On its upper end a float was fitted, this float rising and falling with the waves and sliding up and down the pole. By means of simple mechanism the motions of the float were automatically recorded on a revolving cylinder, and the wave profiles were thus traced.* Waves up to 10 feet in height were thus recorded, and Lieutenant Paris claimed for the instrument a full realisation of the hopes of its inventor. He frankly confessed, however, that "a ship not especially detached for the purpose could hardly be expected to arrest her progress several times a day" in order to make use of the wave tracer. Furthermore, it is evident that in waves of considerable height the instrument could not be used successfully, unless anchored to the undisturbed water lying far below the surface.

In this connection it may be proper to add that the automatic instruments devised by Mr. Froude and M. Bertin for recording the rolling of ships in a seaway, furnish also a means of obtaining valuable information respecting the waves amongst which the ships carrying such instruments may be situated. This will appear from the description given in Chapter VII.

Having briefly described the principal methods of conducting observations on ocean waves, it may be well to summarise the dimensions of the largest waves of which we have any trustworthy accounts. The longest wave observed was measured by Captain Mottez, of the French navy, in the North Atlantic, and had a length of 2750 feet—half a mile—from crest to crest; its period was 23 seconds. Dr. Scoresby speaks of waves he observed in the Southern Indian Ocean spreading out to "a quarter if not half a mile" in one undulation and crest. In the South Atlantic, Sir James Ross observed a wave 1920 feet long. The largest waves observed in European waters are said to have had a period of $19\frac{3}{4}$ seconds, corresponding to a theoretical length of some 2000

* See the *Revue Maritime*, vol. xx., and *Transactions* of the Institution of Naval Architects for 1867.

feet; in the Bay of Biscay waves have been noted having a length of 1320 feet. These monster waves are not, however, commonly encountered, and waves having a length of 600 to 700 feet would ordinarily be regarded as large waves. Dr. Scoresby's largest Atlantic storm waves had lengths of about 500 to 600 feet, and periods from 10 to 11 seconds. According to the best authorities, ocean waves of 24 seconds' period, and some 3000 feet in length, may be taken as the extreme limit of size yet proved to exist; waves of 18 seconds' period, and about 1650 feet in length, constitute the upper limit in all except extraordinary cases; and what may be called common large storm waves have periods varying from 6 to 9 seconds, the corresponding lengths varying from 200 to 400 feet.

Turning next to heights, we find reports of estimated heights of 100 feet from hollow to crest, but no verified measurement exists of a height half as great as this. The highest trustworthy measurements are from 44 to 48 feet—in itself a very remarkable height. Scoresby and others have measured heights of about 40 to 45 feet, and there are numerous records of heights exceeding 30 feet, although waves having a greater height than 30 feet are not commonly encountered. All these figures, be it understood, refer to a single series of waves, and not to one or more series superposed on one another, nor to any great local rise of level due to the waves driving against a shore, or passing over an isolated rock.*

An explanation of the cause of unintentional exaggeration in the estimate of wave heights will at once suggest itself when the variation in the direction of the normal to the wave slope (previously explained) is taken into account. To an observer standing on the deck of a ship which is rolling amongst waves, nothing is more difficult than to determine the true vertical direction, along which the height of the wave must be measured. If he stands on the raft shown in Fig. 64, he will, like it, be

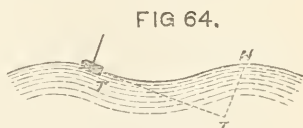

* Exception has been taken to the above statement of maximum wave heights by Commander Kiddle, R.N., in an article appearing in the *Nautical Magazine* for August, 1878. That officer states that in January, 1875, waves 1180 feet long and 70 feet high were observed by him in latitude

48° N., longitude 40° W., during a passage from Queenstown to New York. From the account given of the method of observing the wave heights, it appears that there were several possible sources of error, and of so serious a character as to make the results of questionable value.

affected by the wave motion; and the *apparent* vertical at any instant will be coincident with the masts of the raft and normal to the wave slope. He will therefore suppose himself to be looking horizontally when he is really looking along a line parallel to the tangent to the wave slope at that point, which may be considerably inclined to the horizon. Suppose TT, Fig. 64, to represent this line for any position: then the apparent height of the waves to an observer will be HT, which is much greater than the true height. If the observer stands on the deck of a ship, the conditions will be similar; the normal to what is termed the "effective wave slope"* determines the apparent vertical at any instant; and the only easy way of determining the true horizontal direction is by making an observation of the horizon as described above. The extent of the possible error thus introduced will be seen from an example. Take a wave 250 feet long and 13 feet high; its maximum slope to the horizontal is about 9 degrees. Suppose a ship to be at the mid-height between hollow and crest, and the observer to be watching the crest of the next wave; standing about the water level, the wave height will seem to be about 30 feet instead of 13 feet. The steeper the slope of the waves, the greater liability is there to serious errors in estimates of heights, unless proper means are taken to determine the true horizontal and vertical directions. In some cases the apparent height would be about three times the real height.

Next as to the ratio of the heights to the lengths observed in deep-sea waves. All authorities agree that, as the lengths increase, this ratio diminishes, and the wave slope becomes less steep. The shortest waves are the steepest; and the greatest recorded inclinations are for very short waves where the ratio of height to length was about 1 to 6. For a cycloidal wave it will be remembered that the ratio is about 1 to 3.14; so that in the steepest deep-sea waves observed this ratio is only about one-half that of the theoretical limiting case. For waves from 300 to 350 feet in length, the ratio of 1 to 8 has been observed, but these were probably exceptionally steep waves; for waves of 500 to 600 feet in length, it falls to about 1 to 20; and for the longest waves, of uncommon occurrence, it is said to fall so low as 1 to 50. But it is obvious that all measurements of such gigantic waves must be attended with great difficulties, so that the results, even when the greatest care is taken, are only receivable as fair approximations. It seems probable that, in waves of the largest

* This phrase will be explained in the succeeding chapter.

size commonly met, the height does not exceed one-twentieth of the length; and the higher limit of steepness in ocean waves, which are large enough to considerably influence the behaviour of ships, does not give a ratio of height to length exceeding 1 to 10. Long series of observations made in ships of the French navy show that a common value of the height is about one-twenty-fifth—from one-twentieth to one-thirtieth of the length. Waves from 400 to 900 feet in length are sometimes encountered, having heights of from 4 to 10 feet only, and the small ratio of height to length of 1 to 50 has been repeatedly observed in waves from 100 to 400 feet long.

Excluding these exceptionally low ratios of height to length, and taking account of observations where the ratio did not fall below 1 to 40, the following approximate results have been obtained from an analysis of the published French observations of waves, made in all parts of the world.

Length of Waves.	Number of Observations.	Length ÷ Height.		
		Average.	Maximum.	Minimum.
100 feet and under	11	17	30	5
100 to 200 feet .	55	20	40	9
200 to 300 „ .	44	25	40	10
300 to 400 „ .	36	27	40	17
400 to 500 „ .	17	24	40	15
500 to 650 „ .	16	23	40	17
	179			-

This table is worthy of study; although the figures it contains are not exact, and exception may reasonably be taken to the method of averages as applied to these observations. But it suggests much as to the comparative frequency with which waves of certain lengths occur, and confirms the opinion that waves become less steep as they increase in length.

The comparison of the relation between the periods and speeds of ocean waves, with the relation which should hold in accordance with the trochoidal theory (see page 187), has shown a very fair agreement between theory and observation. In not a few cases there are wide divergencies from such agreement; but it is extremely probable that the observations showing these divergencies were made under the conditions of a confused sea, not embraced by the trochoidal formulæ. It is to be observed that in the cases where a single and approximately regular series of

waves has been encountered, observation and theory agree most closely. For example, Commodore Wilkes observed to the south of Cape Horn waves having a length of 380 feet, and a period of nearly 8.5 seconds; according to the trochoidal theory, the period should have been about 8.6 seconds. Again, Dr. Scoresby observed Atlantic storm waves having lengths of 560 to 600 feet, and periods of about $11\frac{2}{3}$ seconds: the period, according to the trochoidal theory, for a wave 580 feet long, would be about 10.6 seconds. On his voyage to Australia, Scoresby noted waves 640 feet long and $11\frac{1}{2}$ seconds period: the theoretical period for waves of this length would be a little over 11 seconds. Lieutenant Paris, also, in the Southern Indian Ocean measured waves from 300 to 400 metres long, and having a speed of 19 metres per second: their period, according to this data, must have been about 18 seconds, and, according to theory, it would have been about 15 seconds. On another occasion the same observer noted waves 180 metres long, and $10\frac{1}{3}$ seconds period: according to theory the period would have been about $10\frac{3}{4}$ seconds. As a last example, reference may be made to a few observations of waves made in the Pacific on board one of Her Majesty's ships where the periods observed for waves from 180 to 320 feet long agreed almost exactly with the theoretical periods.

Passing from these special test cases to the ordinary cases where waves are less regular and uniform in character, it may be well to give a few examples of the comparison between observed and theoretical lengths of waves. The first table is based upon the results of French observations, exceeding 200 in number, made by different observers on various stations.

LENGTHS OF OCEAN WAVES (IN METRES).

Observed.	Calculated.	Observed.	Calculated.	Observed.	Calculated.
30	30	80	85	143	131
30	42	80	95	148	161
35	42	85	60	150	134
42	42	90	100	153	175
50	60	95	95	160	156
56	60	100	67	165	161
60	52	100	103	170	171
60	67	105	116	170	144
65	52	114	124	172	175
65	73	120	112	180	108
70	67	120	120	180	147
70	74	130	164	180	185
75	60	135	134	190	200
79	80	140	14		

NOTE.—A metre is 3.281 feet.

The second table is based upon observations made on board some of Her Majesty's ships.

LENGTHS OF OCEAN WAVES (IN FEET).

Observed.	Calculated.	Observed.	Calculated.	Observed.	Calculated.
80	82	220	184	375	330
160	123	245	250	400	370
160	184	250	250	420	510
180	185	300	250	500	420
200	184	300	323	530	440
200	250	350	328	630	520

On a review of all the observations with which we are acquainted it appears that usually the observed lengths are, on an average, rather less than the theoretical lengths; but it must be admitted that here also the method of averages is not trustworthy, especially when it is known that in some instances errors of considerable proportionate magnitude exist in the individual observations. These errors arise from various causes; one of the most common being the failure to distinguish correctly the difference between the real and the apparent speeds and dimensions of waves. In addition there are the special difficulties frequently encountered when the waves to be measured are the result of the superposition of two or more series of waves, each moving at its own speed, and all moving, possibly, in different directions. In such a confused sea there is an entire want of regularity or uniformity in successive waves which pass an observer on board a ship, and the best course he can pursue is to note the particulars for a considerable number of waves in order that something like mean results may be obtained. For example, in making a set of observations on board one of Her Majesty's ships, when the sea was formed by two series of waves running at different speeds in nearly the same direction, the following results were noted. First, the intervals which ten successive wave crests occupied in passing over a certain length were respectively 6, 7, 4, 6, 6, 3, 6, 5, 7, and $6\frac{1}{2}$ seconds; the mean being about 5.6 seconds. Second, the apparent lengths varied from 250 to 420 feet. These apparent variations admit of easy explanation, and for this purpose we will take the simple case illustrated by Figs. 65-70. Fig. 65 shows a wave 400 feet long and 20 feet high, having a speed of about 45 feet per second; Fig. 66 a wave 200 feet long and 12 feet high, having a speed of about 32 feet per second. The straight lines in both figures indicate the level of still water. In Fig. 67 the shorter wave is

superposed upon the longer, the latter being shown by a dotted line; the two crests coincide, and the resultant wave has a height from hollow to crest of about 26 feet, while the length from hollow to hollow is about 300 feet. The long wave form gains about

Fig. 65.

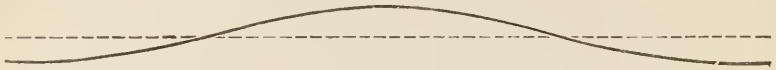

Fig. 66

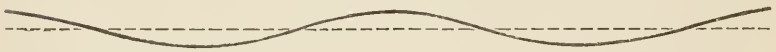

Fig. 67.

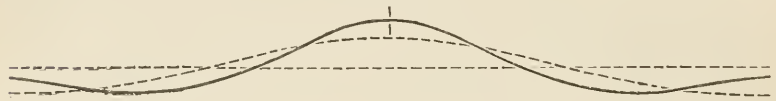

Fig. 68.

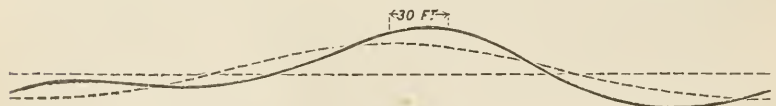

Fig. 69.

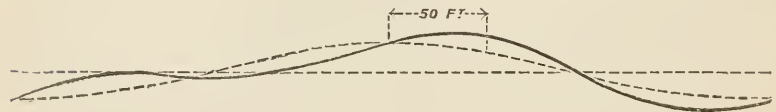
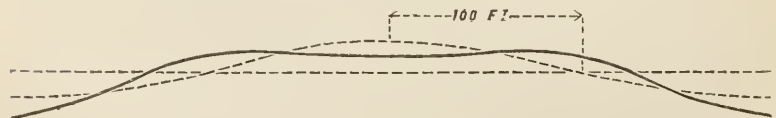

Fig. 70.



13 feet per second on the shorter wave. In $2\frac{1}{2}$ seconds the profile of the combined wave will have changed from the condition of Fig. 67 to that of Fig. 68; the heights of successive crests being about 30 feet and 5 feet, and the length between these crests being

about 200 feet. In less than 4 seconds the further change shown in Fig. 69 will have occurred, and in less than 8 seconds the condition shown in Fig. 70 will have been reached, a wave hollow appearing where the crest of the 400-foot wave is placed. In this last condition the height from this hollow to the adjacent crests is only about 3 feet, and the crests are 160 feet apart. In fact there occurs a long "smooth" in the series, but the next wave series would have heights of about 25 feet. This simple illustration shows how difficult the task of making observations of waves may become in a confused seaway formed by the superposition of several series of waves moving in different directions. Here too we find a satisfactory explanation of the differences sometimes noted in the simultaneous observations of waves by ships sailing in company. In one instance, for example, one ship reported the waves to be 450 feet long, whereas a second ship put the length at 150 feet, and this is by no means an exceptional case. The observer may, it is true, sometimes succeed in distinguishing the principal members of the waves in one or more of the superposed series; but this involves a long continuance of the observations, and is rarely to be accomplished with certainty. It is only necessary to add that in making such observations in a confused sea the fullest particulars should be recorded, for without a knowledge of the attendant circumstances no possible use can be made of the results. For this reason also it is very desirable that any comparisons between the results of theory and observation should be made by the observers at, or soon after, the time the observations are in progress; since no other person can have an equally good knowledge of the particular circumstances of each case.

No theory has yet been accepted which represents the genesis of waves; the trochoidal theory merely deals with waves already created, and maintaining unaltered forms and velocities. There can, of course, be no question but that waves result from the action of the wind on the sea, and that there must be some connection between the character and the force of the wind and the dimensions and periods of the waves. But as yet we have not sufficient knowledge to determine either the mode of action of the wind or the law connecting its force with the dimensions of waves. Here again is a field where careful and extensive observations can alone be relied upon; pure theory would be useless.

In the preceding pages it has been shown that, with care, the lengths, heights, and periods of waves may be determined very closely when the sea is not confused; and it is also possible, with care, to ascertain simultaneously the force or speed of the wind. But it is to be noted that the rapidity with which waves travel, and the fact that they maintain their lengths and speeds almost unchanged even when the force of the wind decreases and the wave height becomes less, make it necessary to exercise great caution in associating any observed force of wind with the lengths and periods of waves observed simultaneously. The importance of this matter justifies further illustration.

If the wind is at first supposed to act on a smooth sea, and then to continue to blow with steady force and in one direction, it will create waves which finally will attain certain definite dimensions. The phases of change from the smooth sea to the fully formed waves cannot be distinctly traced. It is, however, probable that changes of level, elevations and depressions, resulting from the impact of the wind on the smooth surface of the sea, and the frictional resistance of the wind on the water, are the chief causes of the growth of waves. An elevation and its corresponding depression once formed offer direct resistance to the action of the wind, and its unbalanced pressure producing motion in the heaped-up water would ultimately lead to the creation of larger and larger waves. This is probably the chief cause of wave growth, frictional resistance playing a very subordinate part as compared with it. So long as the speed of the wind relatively to that of the wave water is capable of accelerating its motion, so long may we expect the speed of the wave to increase; and with the speed the length, and also the height. Finally, the waves reach such a speed that the wind force produces no further acceleration, and only just maintains the form unchanged, then we have the fully grown waves. If the wind were now suddenly withdrawn, the waves would gradually decrease in magnitude and finally die out. This degradation results from the resistance due to the molecular forces in the wave—viscosity of the water, &c.—and when the waves are fully grown, the wind must at every instant balance the molecular forces. If the water were a perfect fluid (the particles moving freely past one another), and if there were no resistance to motion on the part of the air, the waves once formed would travel onwards without degradation. But in sea-water the degradation takes place at a rate dependent upon the ratio of the resistance of the molecular forces to the “energy”

of the wave.* At each instant the resistance abstracts a certain amount from the energy of the wave, and consequently the height decreases. The period and length of the wave might remain almost unchanged, and, it would seem from observation, really do so, while the height decreases; just as it has been shown that in a ship oscillating in still water the resistance developed gradually diminishes the range of oscillation without decreasing the period sensibly.

Between this condition of fully-grown waves and the case of waves gradually dying out in a dead calm lies that which commonly occurs where the waves are gradually dying out, but the wind still has a certain force and speed. Then an observer, noting the dimensions of the waves and force of the wind simultaneously, might record lengths and periods corresponding, not to the observed force of wind, but to the force which existed when the waves were of their full size. On the other hand, there would, in all probability, be a correspondence between the observed force of wind and the observed heights, and an analysis of the recorded observations made by officers of the French navy confirms this view. Nothing but the closest attention on the part of an observer can enable him to make his records a trustworthy basis for theory; for it is in his power alone, having regard to all the circumstances of the observations, to say whether, when observed, the waves are fully grown, and correspond to the observed force of wind, or whether they are in process of growth or of degradation. A series of observations might settle this matter, if made in a careful and intelligent manner; the growth or degradation being indicated by the alterations in heights of waves noted after certain intervals from the first observations.

Perhaps the most favourable time for observations to be begun would be that when on a nearly calm sea a storm breaks, forming waves of which the dimensions gradually increase, but the opportunities are not likely to be numerous where the waves so formed constitute an independent regular series. Usually the observer would probably find himself in face of a very confused sea, when the wave genesis is in its earlier stages; but if he could note the

* In wave motion the "energy" is half "actual" and half "potential." By "actual" energy is meant that due to the motions of the particles in a wave; by "potential" energy is meant

the work done in raising the centre of gravity of its mass a certain distance above the position which it would occupy in still water. See remarks as to this rise on page 182.

times occupied by waves in attaining their full growth under the action of winds of various speeds, he would do good service. Any pre-existing swell must be allowed for in making these observations; otherwise the assumption that the waves are formed from smooth water would be departed from.

In concluding these remarks on wave genesis, we cannot do better than quote from M. Bertin's essay on the subject, mentioned above:—"The study of the time necessary for each swell "to retain its fixed and permanent condition under the action of "the wind which produces it is very interesting. If the time be "so long as in general to exceed that during which the wind "can remain pretty nearly constant, both in intensity and direc- "tion, all interest in the connection between the wind and the "swell would disappear. The length of waves and their in- "clination for a given length would be just as irregular as "meteorological variations. If, on the contrary, the waves soon "reach their regular condition—a fact which seems to be pretty "well established, inasmuch as those seas which are exposed to "the action of constant winds present no extraordinary agitation "—one is necessarily driven to adopt the law that for each length "of waves there is a certain height that is most commonly met "with, and that cannot be exceeded."

Passing from these general considerations it may be interesting to refer to the attempts made by French investigators to formulate expressions connecting the dimensions of waves with the force or speed of winds. Admiral Coupvent Desbois has laid down a provisional theory, based upon ten thousand actual observations, that the cube of the height of the waves is proportional to the square of the speed of the wind.* Lieutenant Paris suggests, from an analysis of his own observations, that the speed of waves is proportional to the square root of the speed of the wind; but he is of opinion that much more extensive observations are needed before any law can be accepted. Lieutenant Paris' formula may be expressed as follows, reckoning speeds in metres per second:—

$$\text{Speed of wind} = \cdot 073 (\text{Speed of wave})^2.$$

Converting this into English measures, and reckoning speeds in feet per second, we have—

$$\text{Speed of wind} = \cdot 022 (\text{Speed of wave})^2.$$

* See the *Comptes-rendus de l'Académie des Sciences* of 1866.

Whence making use of the formula connecting the speeds and lengths of waves it follows that—

$$\text{Speed of wind} = \cdot 115 \text{ Length of wave.}$$

When the sea was heavy Lieutenant Paris always found the speed of the wind exceed that of the wave form ; but in moderate seas having a speed of 36 feet per second, or less, he frequently recorded speeds of wind which were less than the speeds of the waves formed by the action of that force of wind. The following table contains a few illustrations of this noteworthy feature in these admirable records:—

Locality.	Mean Heights of Waves.	Mean Speeds.*	
		Wind.	Wave.
	Metres.		
Atlantic (region of trade winds)	1·9	4·8	11·2
South Atlantic	4·3	13·5	14
Indian Ocean (south of)	5·3	17·4	15
Indian Ocean (region of trade winds)	2·8	6·5	12·6
Seas of China and Japan	3·2	14·6	11·4
West Pacific	3·1	8·5	12·4

* In metres per second ; a metre is 3·281 feet.

In the present state of our knowledge, we are not able to say that there is anything impossible in the observation of waves moving faster than the winds, which have a force corresponding to their full growth, although this condition would scarcely be anticipated. Remembering what was said above as to the difference between the rates of the actual orbital motions of particles in their circular orbits and the apparent speed of advance of the wave form, it will be clear that, even when the wave form advances faster than the wind travels, the wind may be moving much faster than the particles in the wave. Take, for example, the waves of the Southern Indian Ocean. M. Paris gives them a mean height of 5·3 metres, and a mean period of 7·6 seconds.

Diameter of orbits of surface particles . . = 5·3 metres.

Circumference of orbits of surface particles = 16·6 metres.

Orbital velocity of particles = $\frac{16·6}{7·6} = 2\frac{1}{4}$ metres per second.

Velocity of wind observed = 17·4 metres per second.

Whether the relative velocity of the wind and the wave form should be taken as the measure of the full effect of the wind, or whether the relative velocity of the wind and the particles of water in the wave does not also exercise considerable influence,

must for the present be considered at least a matter open to debate. In the maintenance of the wave speed as the wind speed slackens, we have a possible explanation of the apparent anomaly in the above table; and, further, it is difficult for an observer on board a ship in motion to measure the speed of the wind accurately. But actual observations, such as have been recommended in this chapter, will settle this and many other doubtful points.

M. Antoine, of the French navy, has also endeavoured to frame formulæ connecting the dimensions and speeds of ocean waves with the speeds of wind; and for this purpose has made a very lengthy analysis of the returns furnished by French war-ships.*

Taking 130 observations made in vessels of the French navy, M. Antoine classified them as follows in his Memoir of 1876:—

Speed of Wind.	Number of Observations per Series.	Waves.			
		Mean Lengths.		Mean Heights.	
		Observed.	Calculated by Approximate Formula.	Observed.	Calculated by Approximate Formula.
Metres per Second.		Metres.	Metres.	Metres.	Metres.
1·5	12	54·6	36	1·7	1
4	16	63·7	60	2·4	1·9
7	18	87·9	79·5	3·2	2·7
11	29	79·7	99·6	4	3·7
16	22	100	120	5·4	4·8
22	19	90	141	5·1	5·9
29	11	131	161	7·7	7·1
37	3	180	182	8·5	8·3

It will be observed that the calculated heights agree very closely with the observed heights; whereas there are very considerable differences between the calculated and the observed lengths. This is a suggestive contrast as will appear more clearly in reference to the remarks made on page 203.

In obtaining the approximate formulæ for lengths and heights of waves, M. Antoine uses the following notation:—

Let V = speed of waves (in metres per second),

v = „ wind „

$2L$ = length of waves (in metres)

$2T$ = period „ (in seconds)

$2H$ = height „ (in metres).

* See *Notes complémentaires sur les Lames de haute mer*, 1876; also *Des Lames de haute mer* (Paris, 1879).

Then, assuming Admiral Coupvent Desbois' law to hold, the following are considered to be good approximations:—

$$2H = 0.75 \times v^{\frac{2}{3}} \quad . \quad . \quad . \quad (1)$$

$$2L = 30 v^{\frac{1}{2}} \quad . \quad . \quad . \quad (2)$$

$$2T = 4.4 v^{\frac{1}{4}} \quad . \quad . \quad . \quad (3)$$

$$V = 6.9 v^{\frac{1}{4}} \quad . \quad . \quad . \quad (4)$$

The “constants” in equations (1) and (4), M. Antoine derives from an analysis of numerous observations; those in equations (2) and (3) are derived from (4) by means of the theoretical formula given on page 187.

In his most recent publication, M. Antoine has somewhat varied his procedure, and has attempted to investigate whether “in the deformation of a wave the product of the length by the height would not remain practically constant for waves created by the action of a wind of a given force: the value of this product is termed the *modulus of the wave*.” He retains the fundamental formulæ given above, and as the result of his analysis of over 200 observations forms the following table:—

MODULI OF WAVES (PRODUCT OF HEIGHT BY LENGTH).

Speed of Wind.	Moduli.	
Metres per Second.	Calculated.	Observed.
0 to 2	0 to 51	80
3 to 5	78 to 148	170
6 to 8	184 to 255	362
9 to 13	297 to 443	379
14 to 18	493 to 648	595
19 to 25	685 to 960	650
26 to 32	1010 to 1283	1070
33 to 42	1332 to 1765	1516

M. Antoine adds, “According to the preceding formulæ, the modulus of a wave should be proportional to the expression—

$$(\text{Speed of wind})^{\frac{1}{2}};$$

I reserve to myself the investigation, when more numerous observations have been made, of the problem whether one might not suppose the modulus to be proportional simply to the speed of the wind; which would make the length of a regular wave proportional to the square root of the height.”

Attention has been drawn to the preceding attempts to connect wave phenomena and wind forces with the hope that the subject

will be treated also by English observers with the consideration it undoubtedly deserves. The problem still awaits solution, for the formulæ given above are based upon reasoning to which grave objections may be taken although they cannot be stated here.

Attempts have also been made by Lieutenant Paris to ascertain what are the prevalent waves most likely to be encountered in particular localities. The following table, prepared by him, gives the result of observations extending over more than two years: it stands alone, at present, as an effort to describe the mean condition of the sea. But it is well worthy of the attention of naval officers, who would render good service to science by endeavouring to extend the investigation here begun:—

Locality.	Mean Period.
Atlantic (the Trades)	Seconds, 5·8
South Atlantic (region of the westerly winds)	9·5
Indian Ocean, South (region of the easterly winds)	7·6
Indian Ocean (trade winds)	7·6
China Seas	6·9
West Pacific	8·2

In concluding this chapter, brief reference must be made to the attempts to obtain motive power for propulsion or other purposes from the motions impressed upon a ship by the wave motion. Mr. Spencer Deverell, of Victoria, was the first to draw attention to the subject; and his brother conducted a series of observations in 1873 during a voyage from Melbourne to London, for the purpose of proving that during an ocean voyage a ship will be continually oscillating—rolling, pitching, and heaving—even when there is a dead calm. Limits of space prevent any extracts being given from the interesting records of these observations, which will well repay perusal; nor can any account be given of the apparatus proposed for the purpose of obtaining motive power from the wave motion.* The principle of all the proposals may be simply explained. In a seaway the heaving and other motions impressed upon a ship cause variations in her virtual weight (as

* See Papers on "Ocean Wave Power and its Utilisation," in the *Transactions* of the Royal Society of Victoria for 1873; and "The Continuous Oscillation of a Ship during an Ocean Voyage," in the *Transactions* of the

Institution of Naval Architects for 1874, by Mr. Spencer Deverell; also a Paper by Mr. Tower in the *Transactions* of the Institution of Naval Architects for 1875.

explained at page 186). If a weight inboard is suspended by a spring-balance, the latter will indicate less than the true weight on the wave crest, and more than the true weight in the wave hollow. The *extensions of the spring* will vary according to the virtual weight, being greatest at the wave hollow, and least at the crest. By some appropriate mechanism these varying extensions of the spring are made to produce rotary or other motions. Numerous experiments have been made with models, but hitherto, we believe, no practical use has been made of the principle.

CHAPTER VI.

THE OSCILLATIONS OF SHIPS AMONG WAVES.

IN the two preceding chapters we have discussed the condition of a ship oscillating in still water, and the phenomena of wave motion in the deep sea, subjects which have an interest in themselves, but derive their greatest importance from their connection with the subject now claiming attention. The motions of a ship in a seaway are influenced by her stability, her inertia, by the variations in direction and magnitude of the fluid pressure incidental to wave motion and by the fluid resistance; so that, without clear and correct conceptions of each of these features in the problem, it would be impossible to deal with their combined effect.

All oscillations of a ship in a seaway, like those in still water, may be considered as resolvable into two principal sets: the first, the transverse oscillations of rolling; the second, the longitudinal oscillations of pitching and 'scending. It is, therefore, only necessary to consider these two directions; and of them, the transverse, having by far the most important bearing upon the safety and good behaviour of ships, will receive the greatest attention. Pitching and 'scending may become violent and objectionable in some ships, but this is not commonly the case, nor is it so difficult of correction as heavy rolling. Only a brief discussion of these longitudinal oscillations will therefore be necessary; and it will follow the remarks on rolling.

Very various causes have been assigned for the rolling motion of a ship at sea. Some of the earlier writers, impressed by the great speed of advance of waves, attributed rolling to the shocks of waves against the sides of ships. Others considered motion as originated by the slope of the wave surface; observing that, if a ship remained upright on the wave slope, her displacement would change its form from that in still water, the centre of

buoyancy moving out from below the centre of gravity towards the wave crest, and the moment of stability thus produced tending to make the vessel heel away from the wave crest. But there were obvious objections to both these theories; it is a matter of common experience that vessels often roll very heavily in a long smooth swell, where the slope is so small that the departure from the horizontal is scarcely perceptible, and where no sensible shock is delivered against the sides of the ships. The best of the earlier theories, put forward by Daniel Bernoulli about a century ago, departed from the preceding theories, and was content to speak of the oscillations of a ship as comparable to those of a pendulum, subjected to the action of "impulses" from the waves, no analysis being attempted of the character or causes of these impulses. Some of the conclusions which Bernoulli reached even now command respect; but he, in common with his contemporaries, failed to realise or to express the fundamental condition wherein wave water differs from still water, viz. that the direction and intensity of the fluid pressure are continually varying instead of being constant, as in still water. For nearly a century the subject remained very nearly in the condition in which Bernoulli, Euler, and other writers of that period had left it; and it was reserved for an Englishman, the late Mr. W. Froude, to have the honour of introducing the modern theory of rolling. This theory rests upon the fundamental doctrine, explained in the previous chapter, that in wave water the direction of the pressure at any point is a normal to the trochoidal surface of equal pressure passing through that point; and in that particular the modern theory differs from all that preceded it. It is not put forward as a perfect theory, fully expressing all the conditions of the problem; but it far more completely represents those conditions than any theory which preceded it, and has exercised a great and beneficial effect upon ship designs during the twenty years it has been before the world. Moreover, in its main features, it has secured the adhesion of the greatest authorities on the science of naval architecture, both English and foreign, some of whom have very considerably helped its extension. An attempt to describe in popular language the main features of the theory cannot, therefore, be devoid of interest, even though the avoidance of mathematical language may render the description which follows incomplete.

At the outset it may be well to state that the modern theory of rolling finds the governing conditions of the behaviour of a ship among the waves to be twofold:—

(1) The ratio which the period of still-water oscillations of the ship (or "natural period") bears to the period of the waves amongst which she is rolling.

(2) The magnitude of the effect of fluid resistance.

Both the natural period and the means of estimating the magnitude of the fluid resistance for any ship may be obtained from experiments made in still water, as previously explained.

It will be convenient to deal separately with these conditions, first illustrating the causes which make the ratio of the periods so important, and in doing so leaving resistance out of account; afterwards illustrating the effect of resistance in limiting the range of oscillation. In practice the two conditions, of course, act concurrently; but the hypothetical separation here made will probably enable each to be better understood.

Reverting to the case illustrated by Fig. 61, page 183, where a small raft floats upon the inclined surface (AB) of the water in a vessel which is moving horizontally, it will be noticed that the raft is acted upon by the following fluid pressures:—P, acting downwards on the upper side, an equal pressure, P, acting upwards on the lower side, and the buoyancy b acting normally to the surface AB through the centre of buoyancy of the raft. If w be the weight of the raft (acting vertically downwards through the centre of gravity) when the vessel containing the water is in motion, this weight w must be combined with the horizontal accelerating force due to the motion, in the manner explained on page 184. Using the same notation as before, we have—

$$\left. \begin{array}{l} \text{Resultant of weight and horizontal} \\ \text{accelerating force} \end{array} \right\} = w \sec a,$$

This resultant will act perpendicularly to the inclined water surface, just as the buoyancy b does; and for equilibrium we must have—

$$b = w \sec a,$$

and the line of action of b must pass through the centre of gravity of the raft. Hence it follows that the normal to the free water surface indicates the direction towards which the raft will tend to return if her mast is inclined from it; just as in still water the upright is her position of equilibrium. The normal to the water surface may therefore be termed the "virtual upright" for the raft when it and the water are subjected to horizontal acceleration; since the normal fixes the position of equilibrium.

Next suppose this very small raft to float on the surface of a wave, as in Fig. 62, page 185. Here reasoning similar to the foregoing applies, if the raft be considered so small in relation to the wave that it may be treated as if it replaced a particle, and moved just as the particle would have done. In the preceding chapter it has been shown that at any point in a trochoidal wave the normal represents the direction of fluid pressure at that point, and it has also been stated that this direction changes from point to point along the wave surface, the variations in inclination resembling the oscillation of a pendulum having a period for a single swing equal to half the wave period. The cases of Figs. 61 and 62, therefore differ in this: in the former, where the water surface has a constant inclination, the "virtual upright" also has a constant direction; whereas on the wave the "virtual upright," or position of equilibrium, in which the masts of the raft will lie, varies in direction from instant to instant, the variations being dependent upon the wave slope and wave period. On the wave the raft is also subjected to vertical as well as horizontal accelerations, affecting both the value of the fluid pressure upon its bottom and its own apparent weight, but affecting both equally, and therefore not changing the volume of displacement of the raft from that in still water. The law of this variation in the pressure and apparent weight has been given in the preceding chapter, and illustrated by Fig. 60, but for our present purpose the variation in the direction of the pressure is of greater importance.

A ship differs from this hypothetical raft, having lateral and vertical extension in the wave, as shown by ADC in Fig. 62. Even though she may be small when compared with the wave, it is obvious that she cannot be treated as a single particle replacing a particle in the wave. At any moment she displaces a number of particles which, were she absent, would be moving in orbits of different radii, and at different speeds. Her presence must therefore introduce a disturbance of the internal motions in the wave, and this disturbance must in some manner react upon the ship and somewhat influence her behaviour. At present our knowledge of the conditions governing the internal molecular forces in the waves of the sea is not sufficient to enable exact mathematical treatment to be applied in estimating the effect of this disturbance, and determining at each instant the position of the "virtual upright" for the ship. If the positions of the virtual upright were known, each of them would be a normal to a surface termed "the effective wave slope:" Con-

versely, the effective wave slope may be defined as the surface, the normal to which at any point represents the instantaneous position of equilibrium for the masts of the ship.

Although our knowledge of the subject does not enable the form of the effective wave slope to be accurately determined, certain considerations of a general character are known to influence that form. For example, the size of the ship relatively to the waves, the form of her immersed part, its lateral extension along, and vertical extension into, the waves, as well as the vertical position of her centre of gravity, are all known to affect the effective wave slope. Moreover, that slope may differ considerably from the upper surface of the waves. Large ships, for instance, when floating among very small waves, even with their broadsides to the line of the wave advance, may be supported simultaneously by the slopes of successive waves, and these slopes being inclined in opposite directions, the effective slope may be practically horizontal. Again, a ship of very great breadth, such as the *Livadia*, or the circular ironclads, when floating broadside on to the waves, occupies so great an extent of the slope of one of the largest ocean waves, that the effective slope can only have a very moderate amount of steepness as compared with the maximum slope of the wave surface. And, as a final example, we may take the extreme case of a ship of narrow beam but great draught of water, for which the effective slope would have its steepness decreased in virtue of the fact that trochoidal subsurfaces in a wave are flatter than the upper surface, as explained on page 181.

All these illustrations serve to show that the determination of the effective wave slope for a particular case can only be made approximately. For the purpose of mathematical investigation of the hypothetical case of unresisted rolling it is, however, usual to assume that a ship falls in with waves so large relatively to her own dimensions that she accompanies their motion. Starting with this assumption of the relative smallness of a ship, it has sometimes been assumed that the effective slope will nearly coincide with the trochoidal subsurface passing through the centre of buoyancy of the ship. In Fig. 62, let B represent the centre of buoyancy of the ship shown in section by ACD; then TT_1 , the subsurface of equal pressure passing through B, would be termed the effective wave slope, and the normal to it, NN_1 , would be taken as determining the instantaneous position of equilibrium for the ship. In the diagram the ship is shown purposely with her middle line (GM) not coincident with the

normal NN_1 ; M , the point of intersection of these lines, may be regarded as the metacentre for small transverse inclinations of the ship from the virtual upright; the angle BMN_1 measures the inclination of the ship from the instantaneous position of equilibrium. Through the centre of gravity G , GZ is drawn perpendicularly to NN_1 ; then instantaneously the effort of stability, or righting moment, with which the ship tends to move towards the position NN_1 , is measured by the expression—

$$\text{Righting moment} = \text{apparent weight} \times GZ.$$

In estimating the apparent weight of the ship, which is practically equal to, and has a line of action parallel to, the fluid pressure acting along NN_1 , it is of course necessary to take account of the radii of the particles situated in the subsurface TT_1 . Very often the actual weight may be substituted for the apparent weight without any great error; but this is a matter easily investigated, in accordance with the principles previously explained.

This method of approximating to the effective slope, although widely adopted, is not universally accepted, nor does it profess to be more than an average or approximation under the assumption of the relative smallness of a ship as compared with the waves. In some cases the effective slope lies much nearer the upper surface than TT_1 would be situated, and cases may occur where the effective slope is steeper than the upper surface. But amongst relatively large waves the effective slope is usually less steep than the upper surface; a fact which is confirmed by the careful and extensive observations made by Mr. Froude on board the *Devastation*. In practice, therefore, it is an error on the side of safety to assume, as is not unfrequently done, that the variations in inclination and magnitude of the fluid pressure and the apparent weight of the ship may be determined from the upper surface of the wave. This was the plan adopted by Mr. Froude in his earliest investigations, as well as that followed by the Admiralty Committee on Designs for Ships of War in their estimate of the probable limits of rolling of the *Devastation* class. It will be seen that this substitution of the upper surface for the less steep effective surface in no way affects the period occupied by the wave normal in performing the set of motions from upright at the hollow onward to upright at the crest of a wave. The difference is solely one of the maximum inclination to the vertical reached by the wave normal, and taking the upper

surface usually somewhat increases this beyond the true maximum in the critical cases with which the mathematical theory deals.

Suppose a ship lying broadside-on to the waves to be upright and at rest when the first wave hollow reaches her; at that instant the normal to the surface coincides with the vertical, and there is no tendency to disturb the ship. But a moment later, as the wave form passes on and brings the slope under the ship, the virtual upright towards which she tends to move becomes inclined to the vertical. This inclination at once develops a righting moment tending to bring the masts of the ship into coincidence with the instantaneous position of the normal to the wave. Hence rolling motion begins, and the ship moves initially at a rate dependent upon her still-water period of oscillation. Simultaneously with her motion, the wave normal is shifting its direction at every instant, becoming more and more inclined to the vertical, until near the mid-height of the wave it reaches its maximum inclination, after which it gradually returns towards the upright: the rate of this motion is dependent upon the period of the wave. Whether the vessel will move quickly enough to overtake the normal or not depends upon the ratio of her still-water period to the interval occupied by the normal in reaching its maximum inclination and returning to the upright again, which it accomplishes at the wave crest; this interval equals *one-half* the period of the wave. Hence it appears that the ratio of the period of the ship (for a single roll) to the half-period of the wave must influence her rolling very considerably, even during the passage of a single wave, and still more is this true when a long series of waves move past the ship, as will be shown hereafter.* It will also be obvious that the chief cause of the rolling of ships amongst waves is to be found in the constant changes in the direction of the fluid pressure accompanying wave motion.

As simple illustrations of the foregoing remarks, two extreme cases may be taken. The first is that of a little raft, like that in Fig. 62, having a natural period indefinitely small as compared

* It has already been explained that we follow the Admiralty method in terming a single roll "an oscillation," and the time occupied in its performance the "period of oscillation. Mathematicians commonly apply the term

oscillation to a double roll, and the term period to the time occupied in performing the double roll. We again refer to the matter, as in many published papers the mathematical terms are employed.

with the half-period of the wave. Her motions will consequently be so quick as compared with those of the wave normal that she will be able continuously to keep her mast almost coincident with the normal and her deck parallel to the wave slope. Being upright at the wave hollow, she will have attained one extreme of roll about the mid-height of the wave, and be again upright at the crest; the period of this single roll will be half the wave period. And as successive waves in the series pass under the raft, she will acquire no greater motion, but continue oscillating through a fixed arc and with unaltered period. The arc of oscillation will be double the maximum angle of wave slope.

The other extreme case is that of a very small vessel having a natural period of oscillation, which is very long when compared with the wave period. For instance, a small cylinder like that in Fig. 49, page 137, may be so weighted that the centre of gravity may approach closely to the height of the axis, but remain below it; then, as explained previously, there will be stable equilibrium, and a very long period of oscillation may be secured by disposing the weights towards the circumference of the circular cross-sections. If such a vessel were upright and at rest in the wave hollow, she would be subjected to rolling tendencies similar to those of the raft, owing to the successive inclinations of the wave normal—her instantaneous virtual upright. But her long period would make her motion so slow as compared with that of the wave normal that, instead of keeping pace with the latter, the ship would be left far behind. In fact, the half wave period during which the normal completes an oscillation would be so short relatively to the period of the ship that, before she could have moved far, the wave normal would have passed through the maximum inclination it attains near the mid-height of the wave, and rather more than halfway between hollow and crest. From that point onwards to the crest it would be moving back towards the upright; and the effort of the ship to move towards it, and further away from the upright, would in consequence be diminished continuously. At the crest the normal is upright, and the vessel but little inclined—inclined, it will be observed, in such a sense that the variations in direction of the normal, on the second or back slope of the wave, will tend to restore her to the upright. Hence it follows that the passage of a wave under such a ship disturbs her but little, her deck remains nearly horizontal, and she is a much steadier gun platform than the raft-like vessel.

No ship actually fulfils the conditions of either of these extreme cases, nor can her rolling be unresisted as is here assumed. Expe-

rience proves, however, that vessels having very short periods of oscillation in still water do tend to acquire a fixed range of oscillation when they encounter large ocean waves, keeping their decks approximately parallel to the effective wave slopes. Actual observations also show that vessels having the longest periods of oscillation in still water are, as a rule, the steadiest amongst waves, keeping their decks approximately horizontal, and rolling through small arcs. Hereafter, the details of some of these observations of the behaviour of actual ships will be given; but attention must be confined, at present, to the general hypothesis of unresisted rolling among waves. Having cleared the way by the foregoing illustrations, we shall now attempt a general sketch of the method of investigation introduced by Mr. Froude.

The following assumptions are made in order to bring the problem of the motion of a ship in a seaway within the scope of exact mathematical treatment:—

(1) The ship is regarded as lying broadside-on to the waves with no sail set, and without any motion of progression in the direction of the wave advance: in other words, she is supposed to be rolling passively in the trough of the sea.

(2) The waves to which she is exposed are supposed to form a regular independent series, successive waves having the same dimensions and periods.

(3) The waves are supposed to be large as compared with the ship, so that at any instant she would rest in equilibrium with her masts coincident with the corresponding normal to the "effective slope," which is commonly assumed to coincide with the upper surface of the wave.

(4) The righting moment of the ship at any instant is assumed to be proportional to the angle of inclination of her masts to the corresponding normal to the effective wave slope—the virtual upright.

(5) The variations of the apparent weight are supposed to be so small, when compared with the actual weight, that they may be safely neglected, except in very special cases.

(6) The effects of fluid resistance are considered separately, and in the mathematical investigation the motion is supposed to be unresisted and isochronous (see page 143).

Objections may be raised, with justice, against most of these assumptions: and it was never intended that they should be regarded as including all the varying circumstances which may influence the rolling of a ship among waves. It is only proper to add, however, that the results of experience and observation

confirm the general accuracy of the deductions drawn from the mathematical investigation based upon these assumptions; and this is one great recommendation in their favour. Another fact worthy of notice is that no better and more complete assumptions have been proposed on which to base a rigorous mathematical investigation of the rolling of ships among waves. Many attempts have been made in this direction, but the conclusion reached up to the present time is that the problem lies beyond the reach of purely mathematical treatment, and can only be successfully attacked by the process of "graphic integration," to be described hereafter.

Two possible objections to the foregoing assumptions may be mentioned in passing. It may be thought that since ships much more frequently encounter a "confused sea" than a single regular series of waves, the latter condition should not be supposed to exist. In reply it may be stated that extensive observations of the behaviour of ships seem to show that the irregularities of a confused sea often tend to check the accumulation of rolling, the heaviest rolling being produced by waves which are approximately regular. No doubt there are exceptions to this rule; but, unfortunately, the attempt to express the conditions of a confused sea in the mathematical investigation renders the latter unmanageable. Another possible objection may be taken to the assumption that the ships shall be regarded as small in comparison with the waves. This is not always true; yet it must be noted that—excluding the special case of synchronous oscillations described on page 220—the heaviest rolling is usually produced by the largest waves, while the supposition of relative smallness is favoured by the smallest dimension of the ship—her beam—being presented to the length of the wave.

Upon the basis of the foregoing assumptions, dynamical equations are formed representing the unresisted rolling of the ships. It is impossible, in the present work, to follow out the construction and solution of these equations. The following are the principal steps. Some fixed epoch is chosen wherefrom to reckon the time at which the ship occupies a certain position on the wave slope, and has an unknown inclination (θ) to the vertical. The inclination (θ_1) to the vertical of the wave normal for that position can then be expressed in terms of the steepness of the wave and the wave period; both ascertainable quantities. Next the angle ($\theta - \theta_1$) between this normal and the masts can be deduced from the preceding expressions; and the righting moment corresponding to that angle can be estimated. This moment constitutes

the active agency controlling the motion of the ship at that instant, and it must be balanced by the moment of the accelerating forces, which can be expressed in terms of the inertia of the ship and the angular acceleration.* Finally, an equation is obtained involving the following terms:—The angular acceleration at that instant; the inclination of the masts of the ship to the vertical at that instant; and the effort of stability at that instant. The solution of this equation furnishes an expression for the unknown angle of inclination (θ) of the ship to the vertical at any instant, in terms of her own natural period, the wave period, the ratio of the height to the length of the wave, and certain other known quantities. Assuming certain ratios of the period of the ship to the wave period, it is possible from the solution to deduce their comparative effect upon the rolling of the ship; or, assuming certain values for the steepness of the waves, to deduce the consequent rolling as time elapses and a continuous series of waves passes the ship. In fact, the general solution gives the means of tracing out the unresisted rolling of a ship for an unlimited time, under chosen conditions of wave form and period. A few of the more important cases may now be briefly mentioned, it being understood that the investigation deals with unresisted rolling only.

One critical case is that for which the natural period of the ship for a single roll equals the half-period of the wave. This had been foreseen by several of the earlier writers, including Daniel Bernoulli, apart from mathematical investigation, from the analogy between the motions of a ship and a pendulum. It is a matter of common experience that, if a pendulum receive successive impulses, keeping time with (or “synchronising” with) its period, even if these impulses have individually a very small effect, they will eventually impress a very considerable oscillation upon the pendulum. A common swing receiving a push at the end of each oscillation is a case in point. When a similar synchronism occurs between the wave impulse and the period of the ship, the passage of each wave tends to add to the range of her oscillation, and were it not for the deterrent action of the fluid resistance, she would finally capsize. Such, in general terms, was the opinion of the earlier writers, which recent and more exact investigations have fully confirmed. Apart from the action of resistance, it has been shown that the passage of a single wave

* See the explanations of these terms given at page 135.

would increase the range of oscillation of the ship by an angle equal to about three times the maximum slope of the wave. For instance, in an Atlantic storm wave series, each wave being 250 feet long and 13 feet high, and having a maximum slope of some 9 degrees, the passage of each wave would, if there were no resistance, add no less than 27 degrees to the oscillation of the ship; so that a very few waves passing her would overturn her. Here, however, the fluid resistance comes in, and puts a practical limit to the range of oscillation in a manner that will be explained hereafter.

It may be well to examine a little more closely into the character of the wave impulse which creates accumulated rolling in this case. Suppose a vessel to be broadside-on in the wave hollow when the extremity of her roll is reached, say to starboard, the waves advancing from starboard to port. Then the natural tendency of the ship, apart from any wave impulse, will be to return to the upright in an interval equal to one-half her period, which by hypothesis will be equal to the time occupied by the passage of one-fourth the wave length. In other words, the ship would be upright midway between hollow and crest of the wave near which its maximum slope occurs. Now, at each instant of this return roll towards the upright the inclination of the wave normal, fixing the direction of the resultant fluid pressure, is such as to make the angle of inclination of the masts to it greater than their inclination to the true vertical; that is to say, the inclination of the wave normal at each instant virtually causes an increase of the righting moment. Consequently, when the vessel reaches the upright position at the mid-height of the wave, she has by the action of the wave acquired a greater velocity than she would have had if oscillating from the same initial inclination in still water. She therefore tends to reach a *greater inclination* to port than that from which she started to starboard; and this tendency is increased by the variation in direction of the wave normal between the mid-height and the crest—that part of the wave which is passing the ship during the period occupied by the second half of her roll. On reference to Fig. 62—where the directions of the wave normal are indicated by the masts of the rafts—it will be seen that, when the ship during the second half of the roll inclines her masts away from the wave crest, the angle between the masts and the wave normal is constantly less than the angle they make with the vertical. The effect of this is to make the righting moment less at every instant during the second half of the roll on the wave than it would have been in still water. For

unresisted rolling, it is the work done in overcoming the resistance of the righting couple which extinguishes the motion away from the vertical. On the wave, therefore, the vessel will go further to the other side of the vertical from that on which she starts than she would do in still water, for two reasons: (1) she will acquire a greater velocity before she reaches the upright; (2) she will experience a less resistance from the righting couple after passing the upright. From the above statements, it will be evident that there must be a direct connection between the maximum slope of the wave and the successive increments of her oscillations.

More or less close approximation to this critical condition will give rise to more or less heavy rolling; but it is a noteworthy fact that, even where the natural period of the ship for small oscillations equals the half-period of the wave, and may thus induce heavy rolling, the synchronism will almost always be disturbed as the magnitude of the oscillations increases; the period of the ship will be somewhat lengthened, and thus the further increments of oscillation may be made to fall within certain limits, lying within the range of stability of the ship. It will be understood that this departure from isochronism in no way invalidates what was said in Chapter IV. as to the isochronism of ships of ordinary form when oscillating 10 or 15 degrees on either side of the vertical. The character of the change can best be illustrated by reference to a common simple pendulum. Such a pendulum swinging through very small angles on either side of the vertical has, say, a period of one second; if it swings through larger angles, its period becomes somewhat lengthened, and the following table expresses the change:—*

Angles of Swing.	Period.
	Seconds.
Very small	1
30°	1·017
60°	1·073
90°	1·183
120°	1·373
150°	1·762

For ships the angles of swing are never so great as to make the increase of period great proportionally, but yet, as above remarked,

* See Report of Committee on Designs (1871), where Professor Rankine applied similar reasoning to the dis-

cussion of the probable safety of the *Devastation* class.

the increase may be sufficient to add sensibly to the safety of a ship exposed to the action of waves having a period double of her own period for small oscillations; although it is by the action of resistance that the overturning of a ship so circumstanced is chiefly prevented.

A second interesting deduction from the solution of the general equation for unresisted rolling is found in the "permanent oscillations of ships." If a vessel has been for a long while exposed to the action of a single series of waves, she may acquire a certain maximum range of oscillation, and perform her oscillations, not in her own natural period, but in the possibly different wave period. This case differs from the preceding one in that the period of the ship for still-water oscillations does not agree with the half-period of the wave; but, notwithstanding, the oscillations among waves keep pace with the wave, their period being "forced" into coincidence with the half-period of the wave. At the wave hollow and crest a ship so circumstanced is upright; she will reach her maximum inclination to the vertical when the maximum slope of the wave is passing under her (about the mid-height of the wave); and the passage of a long series of waves will not increase the range of her oscillations, which are "permanent" in both range and period—hence their name. The maximum inclination then attained depends, according to theory, upon two conditions: (1) the maximum slope of the wave; (2) the ratio of the natural period of oscillation of the ship to one-half the wave period.

Let a = maximum angle made with the horizon by the wave profile;

θ = maximum angle made with the vertical by the masts of the ship;

T = natural period of still-water oscillations of the ship;

$2T_1$ = period of wave.

If fluid resistance is neglected, and the conditions above stated are fulfilled, mathematical investigation for this extreme case leads to the following equation:—

$$\theta = a \cdot \frac{1}{1 - \frac{T^2}{T_1^2}} = \frac{a \times T_1^2}{T_1^2 - T^2}.$$

Three cases may be taken in order to illustrate the application of this equation.

1. Suppose $T = T_1$, then θ becomes *infinity*; that is to say, we

have once more the critical case of synchronism previously discussed, respecting which nothing need be added.

II. Suppose T less than T_1 , so that $\frac{T^2}{T_1^2}$ is a proper fraction less than unity: then θ and a always have the same sign, which indicates that the masts of the ship lean away from the wave crest, at all positions, except when the vessel is upright at hollow and crest. The closer the approach to equality between T_1 and T , the greater the value of θ ; which is equivalent to an enforcement of the statement previously made, that approximate synchronism of periods leads to heavy rolling. The smaller T becomes relatively to T_1 , the smaller does θ become; its minimum value being a when T is indefinitely small relatively to T_1 . This is the case of the raft in Fig. 62, which keeps its masts parallel to the wave normal.

III. Suppose T greater than T_1 : then θ and a are always of opposite signs, and, except at hollow and crest, the masts of the ship always lean towards the wave crest. The nearer to unity is the ratio of T to T_1 , the greater is θ ; illustrating as before the accumulation of motion when there is approximate synchronism. The greater T becomes relatively to T_1 , the less does θ become; in other words, as explained above, a ship of very long period keeps virtually upright as the wave passes.

As an example of the use of the formula, take the following figures drawn from the report on the behaviour of the *Devastation* during her passage to the Mediterranean:—

a = maximum wave slope = $1\frac{1}{2}$ degrees;
 T = natural period of ship for single roll . . . = 6.8 seconds;
 T_1 = half (apparent, wave period = 6 „

If the conditions of permanent rolling had been fulfilled, the formula would give—

$$\left. \begin{array}{l} \text{Maximum inclination of ship, sup-} \\ \text{posing motion unresisted,} \end{array} \right\} = 1\frac{1}{2} \times \frac{1}{1 - \left(\frac{6.8}{6}\right)^2}$$

$$= 1\frac{1}{2} \times \frac{1}{1 - 1.28} = 5\frac{1}{3} \text{ degrees (nearly).}$$

The observed oscillation of the ship, from out to out, at this time was about 7 degrees, and the less magnitude of this oscillation, as compared with that given by the formula, must be accounted for chiefly by the want of absolute uniformity in a sufficiently long series of waves to make the rolling permanent, as well as by the steadying effect of the resistance. The example

has, however, been given merely as an illustration of the use of the formula, not as a proof of its accuracy; in practice all deductions from the theory of unresisted rolling, as to the *extent* of oscillation, require to be modified to allow for the effect of fluid resistance. It may be added that an inspection of the records of rolling of a large number of ships, under various conditions of sea, leads to the conclusion that the periods are rarely "forced" into coincidence with the wave-period.

It is possible, by means of very simple experiments, to illustrate the influence which changes in the relative periods of ships and waves may have upon the rolling.* Let AB, Fig. 71, represent a pendulum with a very heavy bob, having a period equal to the half period of the wave. To its lower end, let a second simple pendulum, BC, be suspended, its weight being inconsiderable as compared with the wave pendulum AB: then, if AB is set in motion, its inertia will be so great that, notwithstanding the suspension of BC, it will go on oscillating very nearly at a constant range—say, equal to the maximum slope of the wave—on each side of the vertical. First suppose BC to be equal in length and period to AB: then, if the compound pendulum is set in motion, and AB moves through a small range, it will be found that BC, by the property of synchronising impulses, is made to oscillate, through very large angles. Second, if BC is made very long, and of long period, as compared with AB, it will be found that BC continues to hang nearly vertical while AB swings, just as the ship of comparatively long period remains upright, or nearly so, on the wave. Third, if BC is made very short and of small period when AB is set moving, BC will always form almost a continuation of AB, just as the quick-moving ship keeps her masts almost parallel to the wave normal. These illustrations appeal to many who cannot follow the reasoning, but can apprehend the facts from the experiments.

FIG 71.

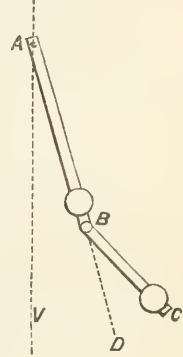

A third notable deduction from the solution of the equation for unresisted rolling is that, except when the conditions of synchronism or permanent oscillation are obtained, the rolling of a ship will pass through phases. At regular stated intervals equal

* Such experiments were made some years ago by the late Professor Rankine and by the Author in connection with his lectures at the Royal Naval College.

inclinations to the vertical will recur, and the range of the oscillations included in any series will gradually grow from the minimum to the maximum after attaining which it will once more decrease. The time occupied in the completion of a phase depends upon the ratio of the natural period of the ship to the wave period. If T = ship's period for a single roll, T_1 = half-period of wave, and the ratio of T to T_1 be expressed in the form $\frac{p}{q}$, where both numerator (p) and denominator (q) are the lowest whole numbers that will express the ratio: then

Time occupied in the completion of a phase = $2q \cdot T$ seconds.

For example, let it be assumed that waves having a period of 9 seconds act on a ship having a period (for single roll) of $7\frac{1}{2}$ seconds.

$$\text{Then } \frac{T}{T_1} = \frac{7\frac{1}{2}}{4\frac{1}{2}} = \frac{15}{9} = \frac{5}{3} = \frac{p}{q}$$

Time for completion of phase = $3 \times 2 \times 7\frac{1}{2} = 45$ seconds.

Although the mathematical conditions for these "phases" of oscillation are not fulfilled in practice, the causes actually operating on the ship—such as the differences in form of successive waves, and the influence of fluid resistance—commonly produce great differences in their successive arcs of oscillation. It is important, therefore, in making observations of rolling to continue each set over a considerable period. In the Royal Navy each set of observations extends over ten minutes, and the minimum inclinations reached are always found to differ considerably from the maximum inclination. The mean oscillation for any set is frequently only a little more than half the maximum inclination, and the following examples are fairly representative in this respect.

DETACHED SQUADRON (1874).

Ships.	Mean Arcs of Oscillation.	Maximum Arcs of Oscillation.
	Degrees.	Degrees.
<i>Newcastle</i>	29·6	58
<i>Topaze</i>	22·6	50
<i>Immortalité</i>	20	39
<i>Narcissus</i>	19·6	36
<i>Doris</i>	18·7	48
<i>Raleigh</i>	5·8	15

CHANNEL SQUADRON (1873).

Ships.	Mean Arcs of Oscillation.	Maximum Arcs of Oscillation.
	Degrees.	Degrees.
<i>Bellerophon</i>	16·9	25
<i>Minotaur</i>	22·3	46
<i>Agincourt</i>	16·4	37
<i>Hercules</i>	8·1	14
<i>Sultan</i>	6·6	12

In comparing the rolling of ships, it is usual to take the mean arcs of oscillation (i.e. the mean of the sums of successive inclinations on either side of the vertical), and on the whole this appears the fairest course. But in analysing rolling returns, it is always desirable to look further, and to note the maximum and minimum oscillations, as well as the rate of growth of the range. All these particulars are readily ascertainable from the forms upon which the records of rolling are kept in the Royal Navy. For considerations of safety, the maximum angle of inclination reached is obviously of the greatest importance; but usually it is taken for granted that vessels will not roll so heavily as to be liable to capsize, and, apart from this danger, the mean oscillations afford the best means of comparing the behaviour of ships.

In concluding these remarks on the hypothetical case of *unresisted* rolling among waves, it may be well to summarise the conclusions which have the greatest practical interest, and to compare them with the results of experience. It need scarcely be remarked again that the actual behaviour of ships at sea is influenced by fluid resistance; and in a later portion of this chapter we shall consider the character of that influence.

First: it appears that very heavy rolling is likely to result from equality or approximate equality of the period of a ship and the half-period of waves, even when the waves are very long in proportion to their height. Many facts might be cited in support of this statement, but a few must suffice. Admiral Sir Cooper Key observed that the vessels of the *Prince Consort* class were made to roll very heavily by an almost imperceptible swell, the period of which was just double that of the ships. Admiral R. Vesey Hamilton informed the Author that, on one occasion, the *Achilles*, a vessel having a great reputation for steadiness, rolled more heavily off Portland in an almost dead calm than she did off the coast of Ireland in very heavy weather. Mr. Froude

reports a very similar circumstance as having occurred during trials with the *Active*. And, lastly, during the cruise of the Combined Squadrons in 1871, when the *Monarch* far surpassed most of the ships present in steadiness in heavy weather, there was one occasion when, through the action of approximately synchronising periods, she rolled more heavily in a long swell than did the notoriously heavy rollers of the *Prince Consort* class.

The effects of approximate synchronism of periods may be tested by changing the course of a ship relatively to the advance of the waves; and this was done most satisfactorily during the trials of the *Devastation*, the ship remaining in the same condition, and the waves, of course, remaining unchanged, while the *apparent period* of the waves was altered by change of course and speed.* Lying passively broadside-on to waves having a period of about 11 seconds, the *Devastation* was observed to roll through the maximum angles of $6\frac{1}{2}$ degrees to windward, and $7\frac{1}{2}$ degrees to leeward, making the total arc 14 degrees. She was then put under weigh, and steamed away from the waves at a speed of $7\frac{1}{2}$ knots, having the wind and sea on her quarter, when her maximum roll to windward became 13 degrees, and to leeward $14\frac{1}{2}$ degrees, making the total arc $27\frac{1}{2}$ degrees. The difference between the two cases is easily explained, in view of the foregoing considerations. When rolling passively in the trough of the sea, the apparent period of the waves was their real period; and this was less than the double period for the *Devastation* ($13\frac{1}{2}$ seconds). When she steamed away obliquely to the line of advance of the waves, their apparent period became increased, and the diagrams of the ship's performance then taken showed that the speed and course of the ship had the effect of making the apparent period of the waves just equal to the period of a double roll for the *Devastation*—in fact, established that synchronism of ship and wave which is most conducive to the accumulation of motion.

This case also furnishes an example of what to every sailor is a truism, viz. that the behaviour of a ship is greatly influenced by her course and speed relatively to the waves. Theory, as we have shown, takes account of the case which is probably the worst for most vessels—the condition of a ship which has become unmanageable, and rolls passively in the trough of the sea. But so long as

* For an explanation of the term "apparent period," see page 191 of preceding chapter.

a ship is manageable, the officer in command can largely influence her behaviour by the selection of the course and speed, which make the ratio of the periods of ship and wave most conducive to good performance. In the case of the *Devastation* just cited, had she steamed obliquely, as before, but head to sea, the apparent period of the waves would have been decreased, and the rolling would probably have been less than it was in either case recorded. Of course, synchronism in some cases may be produced by steaming towards, instead of from, the waves. For instance, if a ship having a period of 4 to 5 seconds had been amongst the waves which the *Devastation* encountered, when broadside-on, her period would have been less than half that of the waves; but if she had steamed obliquely towards the waves, their apparent period might have been lessened, and made about 8 to 10 seconds. However obtained, such synchronism will probably lead to the heaviest rolling the vessel is likely to perform; and the steeper the waves the heavier is the rolling likely to be.

Second: It follows from the investigation for unresisted rolling that the best possible means, apart from increase in the fluid resistance, of securing steadiness in a seaway, is to give to a ship the longest possible natural period for her still-water oscillations. This deduction it is which has been kept in view in the design of many recent war-ships, both English and foreign, and its correctness has been fully established by numerous observations.

It would be easy to multiply illustrations from the published record of rolling of the ships of the Royal Navy, as well as from those of the French navy; but space prevents us from doing this, and we can only give a few, referring the reader to the original documents for more.* During the cruise of the Combined Squadron in 1871 some of the "converted" ironclads of the *Prince Consort* class, and other of the earlier ironclads having short periods were in company with armoured ships of more recent design, having longer periods. The following table of observations refers to a time when the weather was reported to be exceptionally heavy, but unfortunately no particulars were noted of the dimensions and periods of the waves.

* See *Parliamentary Papers*, "Reports on Channel Squadrons," 1863-68; the Report of the Admiralty Committee

on Designs for Ships of War; and various reports on the behaviour of ships in the French navy.

Ships.	Approximate Natural Periods.	Arcs of Oscillation.
	Seconds.	Degrees.
<i>Lord Warden</i>	} 5 to 5½	{ 62
<i>Caledonia</i>		{ 57
<i>Prince Consort</i>		{ 46
<i>Defence</i>	} 7 to 7½	{ 49
<i>Minotaur</i>		{ 35
<i>Northumberland</i>		{ 38
<i>Hercules</i>	8	25

It may be interesting to note that the period of the *Prince Consort* class, from 5 to 5½ seconds, would just synchronise with the half-period of waves from 500 to 600 feet long. It has been stated in the preceding chapter that these are almost identically the dimensions which careful and extensive observations have led us to accept as belonging to the very large Atlantic storm waves Dr. Scoresby and others have encountered. Hence it is easy to explain the relative bad behaviour of these converted ironclads with their quick motion and short period. Another illustration of the superior steadiness of ships of long period may be drawn from the observed performances of the representative ships in the Channel Squadron of 1873, as under:—

Ships.	Approximate Natural Periods.	Mean Arcs of Oscillation.
	Seconds.	Degrees.
<i>Bellerophon</i>	6½ to 7	16·9
<i>Minotaur</i>	} 7 to 7½	{ 22·3
<i>Agincourt</i>		{ 16·4
<i>Hercules</i>	8	8·1
<i>Sultan</i>	8·9	6·6

This, it should be understood, is a fairly representative case, and by no means an exceptional one. In the French navy similar results have been obtained. Almost at the outset of the ironclad reconstruction, the returns from the French experimental squadron of 1863 furnished evidence of the same kind, as the following table shows. The observations were made when the vessels were running broadside-on to a heavy sea.

Ships.	Approximate Natural Periods.	Mean Arcs of Oscillation.
	Seconds.	Degrees.
<i>Normandie</i>	} 5 to 5½	{ 43·6
<i>Invincible</i>		{ 41·4
<i>Couronne</i>	6	37·7
<i>Magenta</i>	} 7 to 7½	{ 36
<i>Solferino</i>		{ 35

The *Magenta* and *Solferino* were making only ten oscillations per minute, whereas the other ships were making twelve.

A more recent and striking contrast is to be found in the behaviour of the French ironclad *Océan* and other vessels of her class, having periods of about 10 seconds for a single roll, as compared with the behaviour of the armoured corvettes of the *Alma* class having periods varying from 5¼ to 5·7 seconds for a single roll. It is recorded that in the first cruise of the *Océan* she never rolled more than 2 to 3 degrees on each side of the vertical, while three of the corvettes were rolling 34, 35 and 36 degrees from the vertical. The maximum inclination to the vertical reached by the *Océan* under any circumstances during this cruise never exceeded 7 degrees. It may be added that experience with the ships of the *Invincible* class in the Royal Navy has given no less satisfactory results. The commanding officer of one of these ships has stated "that they may go through a commission and never heel or roll more than one or two degrees."

Records of rolling have been mostly limited to the behaviour of ironclad ships, the apprehensions entertained in some quarters as to the unseaworthiness and bad behaviour of these vessels having caused greater attention to be bestowed upon them than upon unarmoured vessels. But now that rolling returns have been ordered to be made in all her Majesty's ships, a large mass of facts relating to unarmoured as well as armoured ships has been collected, and is continually being increased. The Detached Squadron has in this way enabled a good comparison to be made between the behaviour of the early types of screw frigates, forming the main strength of the squadron, and that of the swift cruisers which have been in company—particularly the *Inconstant* and the *Raleigh*, both ships of long period. The following table is taken from the observations of rolling made in the heaviest weather experienced by the squadron in the spring of 1875, and, like the other examples given, is only a specimen of many similar cases:—

Ships.	Approximate Natural Periods.	Mean Arcs of Oscillation.
	Seconds.	Degrees.
<i>Newcastle</i>	5	29·6
<i>Topaze</i>		22·6
<i>Immortalité</i>		20
<i>Narcissus</i>		19·6
<i>Doris</i>		18·7
<i>Raleigh</i>	8	5·8

In passing, it may be well to illustrate the importance of the slower motion being associated with the smaller arc of oscillation in ships rolling at sea. In the table on page 230, compare the behaviour of the *Lord Warden* with that of the *Hercules*; the former rolling through an arc of 62 degrees about eleven or twelve times each minute, while the latter rolled through 25 degrees only about seven or eight times each minute. A man aloft, say, at a height of 100 feet, in the *Lord Warden* would be swept through the air at a mean rate of some 1200 feet per minute, having the direction of his motion reversed about every 5 seconds; whereas a man placed as high in the *Hercules* would only be moving at a mean rate of some 350 feet per minute, and be subjected to a reversal of the direction only about once every 8 seconds. The maximum rates in passing through the vertical would of course be greater than these mean rates. Hereafter it will be shown how great are the strains brought upon the structure, masts, and rigging of ships which roll violently and rapidly; but for the present purpose the foregoing figures must suffice. The reader will have no difficulty in multiplying illustrations of the fact, should he so desire.

The remarks on wave genesis made in the previous chapter will assist the explanation of the undoubtedly greater average steadiness of vessels of long natural periods. What may be termed ordinary storm winds may by their continued action produce waves having lengths of 600 feet or under, with periods of 10 to 11 seconds or less; and these waves would have half-periods about equal to the still-water periods of the wooden screw frigates of the older type and the converted ironclads. Extraordinary conditions would, on the other hand, be required to produce waves having periods double the still-water periods now commonly given to the largest war-ships armoured and unarmoured; for these waves would be from 1200 to 1500 feet in length—sizes that have been noted, but are not often encountered. Before such

waves could have reached these enormous dimensions, they would probably have passed through a condition resembling that of the ordinary storm wave; and although, in becoming degraded, they may lose in their lengths much more slowly than they do in their heights, yet they may once more, before dying out, approach the lengths and periods of the ordinary storm wave, being less steep than that wave when fully grown. Summing up, therefore, it appears probable that the ship of long period (say 7 to 9 seconds) will much less frequently fall in with waves synchronising with her own natural period than will the vessel of shorter period (say 4 to 6 seconds); and when these large waves are encountered, their chance of continuance is much less than that of smaller waves; so that on both sides the slower-moving ship gains, when rolling passively in the trough of the sea.

Changes of course and speed of the ship relatively to the waves, as before explained, affect the relation between the periods, and may either destroy or produce the critical condition of synchronism. But this is equally true of both classes of ship, and as long as they remain under control, all ships may have their behaviour largely influenced by such changes, whether their period be long or short. When synchronism is the result of obliquity of course relatively to the waves, it implies the retention of control over the vessel by her commander; for when she becomes unmanageable, a vessel falls off into the trough of the sea. Hence such synchronism in the case of vessels of naturally long period may be easily avoided by change of course; for them rolling passively broadside-on to the longest waves of ordinary occurrence is not the worst condition (see previous case of the *Devastation*). On the contrary, the vessels of shorter period would occupy their worst position relatively to such waves when rolling passively in the trough of the sea. In short, synchronism of periods usually results only from obliquity of course in the vessels of long period; it can only be avoided in storms of average severity by obliquity of course in the quicker-moving ships. The contrast of conditions speaks for itself.

One other important point of difference between very long waves and ordinary large storm waves is the much less comparative steepness of the former. The fact was illustrated in the previous chapter; its bearing upon the behaviour of ships will be obvious if the previous remarks on the influence of the maximum wave slope are recalled to mind. It has been shown that the upper limit attained during rolling motion is very largely governed by that slope, as well as by the ratio of the

periods. Hence, for a certain fixed ratio of periods, that ship will fare best which encounters the flattest and longest waves. Probably few waves having the large periods of 13 to 16 seconds have slopes exceeding 4 or 5 degrees; whereas waves having periods of 8 or 10 seconds have been observed to slope 9 or 10 degrees to the horizon. Moreover, when the condition of synchronism of periods results from the oblique motion of a ship relatively to waves, that obliquity produces a virtual reduction of the wave slope, and thus favours ships of long period when rolling among ordinary storm waves.

Third: It appears from the investigation of unresisted rolling that vessels having very quick periods, say 3 seconds or less for a single roll, fare better among ordinary large storm waves than vessels having periods of 4 to 6 seconds. The tendency in these very quick-moving vessels is to acquire a fixed range of oscillation, keeping their decks approximately parallel to the effective wave slope, as described for the little raft in page 185. As examples, the deep-sea fishing-boats used off the Dutch coast at Scheveningen may be named; and amongst war-ships, the American monitor type. It is reported of the *Miantonomoh*, which crossed the Atlantic about twenty-two years ago, with a height of upper deck above water of only 3 feet, that she rolled but moderately in heavy weather, and shipped very little water on her low deck, even when broadside-on to large waves, the water which did come on the deck on the weather side usually passing off again on the same side as that it broke over. This is very good evidence that the motions of the monitor were so quick relatively to the wave motion that her deck was kept approximately parallel to the surface; otherwise, with the low freeboard, much greater quantities of water would have been shipped. Obviously such a vessel would not be a steady gun platform, as the range of her oscillation might be considerable, being governed by the wave slope. For instance, if the *Miantonomoh* were placed broadside-on to Atlantic storm waves such as Dr. Scoresby observed, say, 600 feet long and 30 feet high, the maximum slope of the wave would be about 9 degrees, and its period about 11 seconds. Once in every $5\frac{1}{2}$ seconds (the half-wave period), therefore, if the ship kept pace with the wave, she would really swing through a total arc of 18 degrees—9 degrees on either side of the vertical, although to an observer on board, owing to causes explained in the preceding chapter, she might seem to continue nearly upright. The wave period is about twice the natural period for a double roll of the monitor. In other words, while

the wave normal or virtual upright in $5\frac{1}{2}$ seconds completes a single set of motions between the hollow and crest, the monitor can move twice as quickly, and may therefore keep her deck nearly parallel to the surface.

When this quickness of motion is obtained by the adoption of great beam a vessel has the further advantage (explained on page 214) of a very flat effective wave-slope, so that her range of oscillation may be very limited even among large waves. The Russian circular ironclads and the *Livadia* are examples of this class. They are reported to be wonderfully steady; and in exceedingly heavy weather in the Bay of Biscay the maximum roll of the *Livadia* is stated to have been only 4 degrees.

Somewhat different conditions hold in the cases of small sea-going vessels, for which the still-water periods are made short by the smallness of their moment of inertia, and the necessity for retaining a sufficient amount of stiffness. For such vessels the effective slope is very nearly the upper surface of the waves, and their range of oscillation among large waves is practically determined by the wave slope. Amongst smaller waves, approaching the condition of synchronous periods, these small vessels are much worse off than very broad vessels of identical period, because the effective slope for the broad vessels is so much flatter. In fact a small vessel of 3 seconds' period among waves of about 180 feet in length, might accumulate motion and roll heavily, much as larger vessels of from 4 to 6 seconds' period have been shown to do among ordinary large Atlantic waves. The *Livadia*, on the contrary, with her beam of 150 feet, might remain almost free from rolling, even when her period was nearly identical with that of the waves. On the other hand, it must be noted, and will be more fully illustrated hereafter, that in these small vessels the accumulation of rolling motion may be checked by the use of bilge-keels to an extent not possible in larger vessels.

Only a passing notice has been bestowed hitherto upon the very important effects of fluid resistance in modifying the rolling of ships among waves. This branch of the subject is, however, of great interest, and has attracted the attention of several able investigators: although they are not agreed in all points, there are many general considerations which command universal support; to some of these brief reference will now be made.

The deductions from the hypothetical case of *unresisted* rolling,

to which attention has been drawn, can be regarded only as of a qualitative and not of a quantitative character. For example, one of these deductions is that a ship rolling unresistedly among waves having a period double her own natural period will accumulate great rolling motion, and infallibly upset. As a matter of fact, we know that, while the assumed ratio of periods leads to the production of heavy rolling, ships do not commonly, nor in any but exceptional cases, upset under the condition of synchronism; in other words, the *character* of the motion is well described by the deduction from the hypothetical case, but its *extent* is not thus to be measured. Similarly, in other cases, the effect of resistance must be considered when exact measures of the range of oscillation are required, as they may be in discussing the safety of ships. The problem, therefore, resolves itself into one of correcting the deductions from the case of unresisted rolling, by the consideration of resistance coming into play.

In accordance with the principles explained in Chapter IV., it is possible by means of still-water rolling experiments to ascertain the amount of resistance of a ship corresponding to any assigned arc of oscillation. If the ship herself has not been rolled for that purpose, but a model or a sister ship or similar vessel has been so rolled, her coefficients of resistance may be estimated with close approximation, and the retarding effects of resistance may be determined. This is true within the limits of oscillation reached by the still-water experiments, say, 10 or 15 degrees on each side of the vertical, and in high-sided ships of ordinary form the limits may probably be extended. In fact, it may be assumed that the coefficients of resistance for most ships are or may be ascertained by these rolling experiments for inclinations as great as are likely to be reached by the same ships when rolling in a seaway, in all but exceptional circumstances.

If a vessel rolls through a certain arc amongst waves, it appears reasonable to suppose that the effect of resistance will be practically the same as that experienced by the ship when rolling through an equal arc in still water. The intrusion of the vessel into the wave, as already remarked, must somewhat modify the internal molecular forces, and she must sustain certain reactions, but for practical purposes these may be disregarded, not being proportionally large.

Resistance is always a retarding force; in still water it tends to extinguish oscillation; amongst waves it tends to limit the maximum range attained by the oscillating ship. This may be well seen in the critical case of synchronism; where a ship rolling unresistedly would have a definite addition made to her oscillation

by the passage of each wave. The wave impulse may be measured by the added oscillation; the dynamical stability corresponding to the increased range expressing the "energy" of the wave impulse. At first the oscillations are of such moderate extent that the angular velocity is small, and the wave impulse more than overcomes the effect of the resistance; the rolling becoming heavier. As it becomes heavier, so does the angular velocity increase, and with it the resistance; at length, therefore the resistance will have increased so much as to balance the increase of dynamical stability corresponding to the wave impulse—then the growth of oscillation ceases. As successive waves pass the ship after this result is attained, they each deliver their impulse as before, but their action is absorbed in counteracting the tendency of the resistance to retard and degrade the oscillations.

When a ship is rolling "permanently" amongst waves, her oscillations having a fixed range and period, a similar balance will probably have been established between the wave impulse and the resistance; and here also the actual limit of range will fall below the theoretical limit given by the formula for unresisted permanent rolling on page 223. Resistance may, in this case, be viewed as equivalent to a reduction in the *steepness* of the waves; this diminished slope taking the place of what has been termed the "effective slope" for unresisted rolling.

Assuming that the coefficients of resistance for a ship have been determined experimentally, and that the curve of stability has been constructed, it is possible to trace her behaviour among waves of any selected form by means of the process of "graphic integration," introduced by the late Mr. Froude. This process may be regarded as the most valuable means yet suggested for approximating to the maximum rolling to which a ship is likely to be subjected in a seaway, and for pronouncing upon her safety against or liability to capsizing. It has already been applied in certain critical cases, and its accuracy has been confirmed by comparisons of the results obtained by its use with the actual behaviour of ships.* No detailed description of the process can be given here, but it may be interesting to give an illustration of its application. Fig. 71a contains the result of an investigation made for H.M.S. *Endymion* when rolling, with no sail set, among

* For an example of these comparisons see the appendix to the Report of the *Inflexible* Committee (*Parliamentary Paper C-1917* of 1878): and

for a detailed account of the process of graphic integration, see the *Transactions* of the Institution of Naval Architects for 1875 and 1881.

waves 512 feet long and 22 feet high. On the base-line AB , abscissæ measurements correspond to *time* reckoned from some selected epoch. Any ordinate of the curve of "wave slope" shows the slope of the effective wave surface to the horizon at the instant fixed by the corresponding abscissa. Similarly any ordinate of the curve of "inclination of ship" shows the angle which her masts make with the vertical at the corresponding time. Hence it follows that the intercepts, or lengths of ordinate, between the curves of inclination and wave slope show for each instant the angle of inclination of the masts of the ship relatively to the normal to the wave slope, which angle, as previously explained, governs the virtual righting moment, and enables an opinion to be formed as to the stability or instability of a ship.

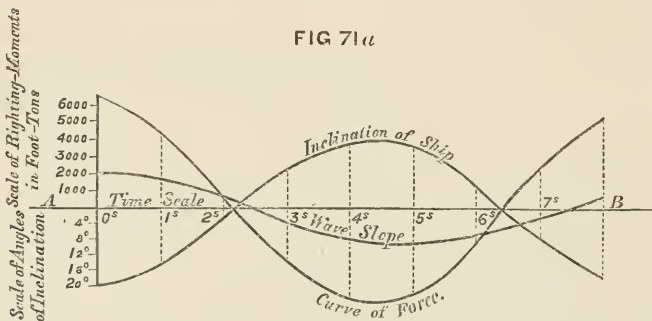

The "curve of force" in Fig. 71a has ordinates representing successive values of the moment of the impressed forces acting on the ship. For example, in the case under consideration, the moment of the impressed forces at any time includes the instantaneous righting moment and the instantaneous moment of resistance. During certain parts of the motion of the vessel the instantaneous righting moment tends to add to her angular velocity, while the moment of resistance tends to diminish it; the corresponding ordinates of the force curve then represent the *differences* between the moments. During other parts of the motion the righting moment, as well as the moment of resistance, tends to retard the angular velocity; and the corresponding ordinates of the force curve represent the *sums* of the moments. In building up the force curve it is necessary to know, therefore, instant by instant the inclination of the masts of the ship to the wave-normal and her angular velocity, because the instantaneous righting moment depends upon that inclination, while the moment of resistance is governed by the angular velocity. The process is really one of "trial and error,"

but each step admits of a complete check and verification in consequence of the inter-dependency of the curve of inclinations and the force curve. In practice, the work of graphic integration can be rapidly performed, and after certain preliminaries have been arranged in any particular case, the remaining steps are very simple.

It will be understood that the process of graphic integration is based on strict mathematical reasoning; but it surpasses any purely mathematical investigation in its inclusion of the effect of fluid resistance, and in its scope of application. By means of this process the rolling of a ship in the most confused seaway can be approximated to, the appropriate curve of wave-slope being supposed to be known. The behaviour of the same ship under different conditions of sea can be compared; the probable effects of changes in bilge-keels, &c., can be investigated; and the probable rolling of different types under identical conditions of sea can be contrasted. It is greatly to be desired that comparisons might be multiplied between the observed behaviour of ships and their probable behaviour deduced by means of graphic integration. Such comparisons would doubtless have the effect of still further establishing the great practical utility of the process; and they would probably throw much light upon certain obscure questions, particularly upon those relating to the effective wave slope.

Another method of investigation for the maximum rolling of ships among waves, including the effect of fluid resistance, has been proposed by M. Bertin, and deserves mention, although it does not compare, in our judgment, with the process of graphic integration, either in completeness or in the scope of its application. Starting from the fundamental conception that the heaviest rolling will take place when a ship is exposed to the action of waves whose period equals the still-water period of the ship for a double roll, M. Bertin considers that, apart from the action of resistance, the passage of each half wave would add to the amplitude of the oscillation of the ship an angle equal to the maximum slope of the effective wave surface. This estimate, it may be observed, differs somewhat from that of Mr. Froude, mentioned on page 221; but the difference is unimportant. Even when resistance is operating the wave form tends to add to the amplitude of successive rolls, and will do so until a range of oscillation is reached, for which the work done in overcoming the moment of resistance balances the work (or dynamical stability) corresponding to the increase of amplitude which the passage of

the wave tends to create. Using M. Bertin's notation:—

Θ = the maximum slope of the effective wave surface ;

ϕ = the maximum amplitude of rolling ;

N = coefficient of resistance deduced from still-water rolling experiments.

Then, as explained on page 159, M. Bertin would write

$$\Delta\phi = \text{loss of range due to resistance} = N\phi^2;$$

and on the foregoing assumptions he would also write

$$\Delta\phi = \Theta;$$

so that

$$N\phi^2 = \Theta.$$

“Supposing that the quantities neglected in the calculation affect the values of ϕ in very nearly the same manner for all ships,” M. Bertin finally proposes to introduce a constant into this last equation, writing it

$$N\phi^2 = l^2 \cdot \Theta.$$

In his examples this constant is usually omitted. For instance, *La Galissonière* has a value of $N = \cdot 0075$, and when among synchronising waves, for which $\Theta = 9^\circ$, her maximum roll is given by the equation

$$\sqrt{\frac{\Theta}{N}} = 34^\circ \cdot 7.$$

The reciprocal of \sqrt{N} M. Bertin terms the *coefficient d'ecclisité*. In the examples given by him it varies from 8 or 9 in the smaller classes of unarmoured war-ships, up to 11 to 15 in armoured ships. Roughly speaking, if 9 degrees is a fair average slope for ocean waves of large dimensions, the maximum roll obtained from the above formula would be three times the *coefficient d'ecclisité*.

From this brief description it will be observed that M. Bertin here confines attention to the critical case of synchronism, and does not attempt the discussion of the limits of rolling likely to be reached by a ship among waves of other periods. He is careful to note the fact that this critical case is less likely to occur as the still-water periods of ships are lengthened; and that for certain classes of war-ships the periods are so long that they are never likely to encounter synchronising waves. In order to meet such cases of departure from synchronism M. Bertin has proposed an empirical formula, which need not be reproduced here.*

* For full details of these investigations, see *Les Vagues et le Roulis*. Paris, 1877.

The broad practical deduction from all these investigations is that any increase in the fluid resistance to the rolling of a ship tends to limit her maximum oscillations among waves. It has already been explained (see Chapter IV.) that in the use of bilge-keels is found one of the most convenient and effective methods of influencing the resistance to rolling, and that their employment is most effective in small ships of short period. Formerly some high authorities in the science of naval architecture opposed the use of bilge-keels; but extended experience has placed the matter beyond doubt, and it may be well to quote a few facts in support of this opinion. The Admiralty Committee on Designs took evidence in 1871 as to the advantages or otherwise of bilge-keels; this evidence was not unanimously favourable to the use of such keels, but its general tenour was so. Some of the Indian troopships had been fitted with deep bilge-keels at that time, and the reports of their effect on the behaviour of the ships were most definite. The captain of the *Serapis* reported that the bilge-keels, having been tried under all conditions of wind and sea, had proved a perfect success, and added, "I can confidently say her rolling has been lessened 10 degrees each way." As regarded the *Crocodile*, no similarly severe tests had at that time been made, but the opinion was confidently expressed that "the rolling had been much checked by the bilge-pieces," the ship having often rolled heavily before they were fitted, and being considered "remarkably steady" afterwards. Mr. Froude also came forward with the reports of his experiments on models, and strongly recommended the use of deep bilge-keels—a recommendation which was endorsed by the committee in their report. These experiments were made at Spithead with the same model of the *Devastation* as had previously been used to determine the effects of different depths of bilge-keels upon still-water oscillations.* At the time considerable doubt was entertained in some quarters as to the safety of the *Devastation*; and it was intended to try the model amongst waves having approximately the same period as its own for a double roll, in order to obtain a verification of the theoretical investigations of the probable behaviour of the ship when similarly circumstanced. Waves were found having the desired period, but they proved to be proportionately much steeper than any waves would be that would synchronise with the double period of the ship. Hence the trials became simply a test of the relative merits of the

* See the accounts of these experiments at page 163.

different bilge-keels, and in no sense a representation of the probable behaviour of the ship. The results were found to be as follows :—

Condition of Model.	Maximum Angle attained.
With 6 feet bilge-keel on each side	5 degrees.
" 3 feet "	13½ "
" no bilge-keels	Model upset.

The deeper bilge-keels, therefore, proved very influential in limiting the range of oscillation, the waves remaining of the same character, and the variations in the depths of the keels being the only changes made during the trials.

The most complete evidence of the usefulness of bilge-keels in limiting the rolling of ships in a seaway is that afforded by the experiments made off Plymouth in 1872. Two sloops, the *Greyhound* and *Perseus*, had been placed by the Admiralty at the disposal of Mr. Froude for this purpose; the *Greyhound* was fitted with temporary bilge-keels about 3½ feet deep, which were not applied to the *Perseus*. So far as external form and dimensions were concerned, the two vessels were very similar; and by means of ballast they were made to have practically the same draught of water and still-water period; the latter being about 4 seconds for a single roll. With the one exception of the bilge-keels, the conditions influencing the behaviour of the two ships were thus made as nearly as possible identical; and their comparative rolling, when exposed to the same series of waves simultaneously, necessarily afforded a measure of the effect of the bilge-keels. When the trials were made, the waves were of moderate length, and from 4 to 5 seconds' period; the two vessels were towed out and placed broadside-on to the waves, in immediate neighbourhood, but not so close to one another as to favour one by any shelter from the other. Their simultaneous rolling was then observed, and the *Perseus* was found to reach a *maximum* roll about twice as great as that for the *Greyhound*; the proportions for the mean oscillations of the two ships being much the same as those of the maximum. Thus, taking twenty successive rolls, the mean for the *Greyhound* was less than 6 degrees, whereas that for the *Perseus* was 11 degrees; the maximum inclination of the *Greyhound* during this period was about 7 degrees, that for the *Perseus* about 16 degrees. Comment upon these facts is needless.

The accidental loss of a portion of one of the temporary bilge-keels attached to the *Greyhound* at the end of these trials furnished an unlooked-for illustration of their beneficial effect. Such a loss would not have occurred in a vessel with permanent bilge-keels, but the deep bilge-keels in the *Greyhound*, being fitted for experimental purposes only, were not very strongly secured to the hull, and a portion of one gave way. Its loss was not known until afterwards, but it was noticed that the behaviour of the ship had sustained a sudden change, the rolling being more heavy than before; and the cause could not be detected until the detached portion of the bilge-keel was seen floating alongside.

This careful and conclusive series of experiments does not, of course, fairly represent the ordinary conditions of bilge-keel resistance, the depth of the keels fitted to the *Greyhound* being proportionately very great indeed. But it exemplifies what may be accomplished in this direction, and the facts obtained are very valuable for the future guidance of naval architects. Circumstances may and do arise in the designing of war-ships which make it difficult, if not impossible to associate requisite qualities with the long still-water period which theory and observation show to be favourable to steadiness. In all such cases the use of bilge-keels must be advantageous, and in ships of small size their effect may be most marked in limiting rolling. Merchant ships with periods varying greatly according to the nature and stowage of their cargoes may also derive benefit in all conditions from bilge-keels. In the Royal Navy such keels have been commonly fitted throughout the period of the ironclad reconstruction; in the mercantile marine they are now very frequently fitted. Care has to be exercised, of course, in fitting such keels, in order that they may not interfere with the speed or steering of the ships; and it is customary to fit bilge-keels only over about one-half of the length amidships, leaving the extremities free from such appendages.

The extinctive effect of the "water-chamber" provided in the *Inflexible* and other armoured ships of great stiffness, broad beam, and moderate period, has been mentioned on page 166. It may be added here that on the passage of the *Inflexible* to the Mediterranean she encountered very heavy weather in the Bay of Biscay; and notwithstanding her moderate period ($5\frac{1}{2}$ seconds) she never rolled more than 10 or 11 degrees to the vertical, even when exposed to the action of waves having apparent periods very nearly synchronising with her own period and having heights from 20 to 25 feet. This good behaviour may have been partly

due to the great beam (75 feet), but must have been largely influenced by the free-water in the chamber aft.

It need hardly be added that, in making these lengthy references to bilge-keel resistance and the extinctive effect of contained water, it is not intended to pass by the fact that the form of the immersed part of a ship and the condition of her bottom very considerably affect the aggregate resistance. But all these conditions are included in the determination of the coefficients of resistance to rolling; and, moreover, the form of a ship is determined by the naval architect mainly with reference to its stability, carrying power and propulsion, not with reference to the increase of the resistance to rolling. The latter is a subordinate feature of the design, and is best effected by leaving the under-water form of the ship herself unaltered, and simply adding bilge-keels. The depths of these keels should be made as great as possible consistently with the conditions of service of the ship, the sizes of the docks she has to enter, or other special circumstances.

Certain classes of ships present singular features considerably affecting their behaviour at sea. Vessels with projecting armour, like the American monitors, or the *Glatton* in the Royal Navy, or the *Devastation* class as they were originally designed, really possess in these projections virtual side-keels of great efficiency in adding to the resistance to rolling; and the records of the behaviour of American monitors prove that the projections had a steadying effect. There was, however, the drawback that the alternate emersion and immersion of the armour shelf brought considerable shocks or blows upon the under side of the projecting armour, tending to shake and distress the fastenings of these singularly constructed vessels. Similar shocks were experienced in the *Devastation* when rolling in a seaway, although the vastly different construction of the armoured side prevented any injurious effects similar to those said to have been experienced in the American monitors. After several trials it was decided to "fill-in" the projection of the armour shelf in the *Devastation* in order to avoid the shocks; the reduction of the resistance being accepted when it had been ascertained beyond question that the vessel was singularly steady and well behaved.

Low freeboard also, as previously explained, develops deck resistance by the immersion and emersion of the one or other side that accompanies moderate angles of rolling; and observations of the behaviour of monitors amongst waves have clearly shown that conditions similar to those of still water obtain also

for rolling amongst waves. In vessels of ordinary forms and good freeboard nothing similar to this deck resistance exists; and therefore in monitors the use of bilge-keels is not so necessary as it is in ordinary vessels.

Up to this point attention has been confined to the rolling of ships among waves when no *sail is set*; it now becomes necessary to attempt an explanation of the still more difficult case where a ship under sail is exposed to the action of the wind and waves. This explanation must necessarily be brief, and the avoidance of mathematical language must make it even more imperfect than it would otherwise have been. We would refer the reader desirous of following out the subject to a discussion which is as full as the present state of our knowledge seems to permit, and which summarises both what is known and what yet requires to be determined.*

When a ship with sail set is rolling amongst waves, the forces operating upon her at each instant include all those which would be in operation if there were no sail set; and, in addition, the moment of the wind-pressure on the sails, as well as the moment of the resistance of the air to the oscillatory motions of the sails. Our knowledge of the laws which govern the pressure of the wind on the sails is very imperfect; a brief *résumé* of that knowledge will be found in Chapter XII. Exact estimates cannot be made, therefore, for the moment of the wind-pressure at any instant, even when the inclination of the masts to the vertical, the instantaneous angular velocity of the sails, and the direction and velocity of the wind are known. But, while this is true, certain general principles may be established. For example, as a ship rolls to windward the angular velocity of the sails increases the relative velocity of the wind past the sails, and this increase is greatest on the sail-area which is highest above water. Consequently, during this roll to windward, the moment of the pressure of the wind on the sails is increased, not merely by the greater relative velocity of the wind on the sails, but by the higher position of the centre of pressure. Conversely, during the roll to leeward at any instant the inclining moment of the wind-pressure is decreased, and may be very largely decreased, by the angular velocity of the sails. Any attempt at

* See the Paper on the "Rolling of Sailing Ships" contributed by the Author to the *Transactions* of the Institution of Naval Architects for 1881.

exact investigation must take account, therefore, of these variations in the moment of the wind-pressure.

Account must also be taken of the effect which the heaving motion produces upon the instantaneous righting moment which the ship can oppose to the inclining moment of the wind-pressure. It has been shown (on page 186) that a ship accompanying the motion of the waves, and heaving up and down as they pass under her, is subjected to accelerating forces which alternately tend to increase and decrease her "virtual weight." Now the "instantaneous righting moment" is equal to the product of that virtual weight into the ordinate of the curve of stability corresponding to the instantaneous inclination of the masts to the normal to the effective wave slope. An illustration of this statement is given in Fig. 72. NN_1 shows the instantaneous direction

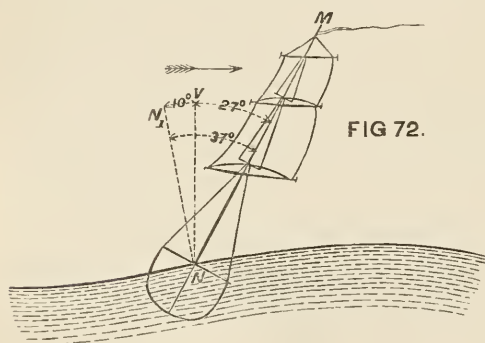

of the normal (that is the "virtual up-right"). The masts are inclined to the normal at an angle of 37 degrees. The instantaneous righting moment equals the product of the "virtual weight" (allowing for heaving) into the arm of the righting lever measured

on the curve of stability for 37 degrees inclination. When the ship floats on the upper half of the waves her virtual weight is less than the true weight, and may be as much as 20 per cent. less. Consequently her instantaneous righting moment on the upper half of the waves is correspondingly decreased. And since the force of the wind is not similarly affected by the wave motion, it must during this time have a greater inclining effect upon the vessel than the same force of the wind would have in still water. It is a matter of common observation, which the foregoing remarks may help to explain, that boats and small craft are most frequently capsized when floating on wave crests. Of course, on the lower half of the waves, from mid-height to hollow, the virtual weights and instantaneous righting moments are greater than the corresponding values in still water.

Fig. 72 also serves to illustrate another point of importance, viz. that on the supposition that the wind acts horizontally, the

moment of the wind pressure must be estimated in terms of the inclination of the masts to the vertical at each instant. Whereas, in consequence of the variations in the direction of fluid pressure, the stability or instability of the ship must be estimated by the inclination of the mast to the normal to the effective wave slope. In Fig. 72 NV is the vertical; the masts are inclined 27 degrees to it, but the wave slope adds 10 degrees to this inclination, and makes the angle by which safety or danger of capsizing is to be reckoned 37 degrees. Remembering what has been said in Chapter V. of the steepnesses of waves, it is desirable, when considering the sufficiency of the range of the curve of stability for any vessel, to regard it as abridged by 8 or 10 degrees in order to allow for the influence of wave slope upon the virtual inclination to the position of instantaneous equilibrium.

A ship with sail power, besides having provision made for resisting the heave of the sea, like a mastless ship, must be capable of resisting the heeling action of a steady force of wind continually applied, as well as the impulsive action of gusts and squalls. For all these reasons a rigged ship requires a greater range of stability than a vessel of the mastless type, and a glance at the curves of the typical ships in Fig. 47 will show that in all the types of rigged war-ships therein represented, except the ill-fated *Captain*, this condition was complied with. In her case, however, the range of stability was very moderate: her initial stability not great, and her sail spread large for an ironclad, all of which causes contributed to her capsizing. Without discussing the circumstances further, it may be interesting to make use of the ship for purposes of illustration, since we have very full published accounts of her qualities.

Suppose the *Captain*, with no sail set, to have floated on a wave 400 feet long and 22 feet high, having a maximum surface slope of about 10 degrees. The total range of stability for the ship (see curve 10 in Fig. 47) being 54 degrees, if the allowance of 10 degrees be made for wave slope, there will remain 44 degrees, measuring the inclination to the vertical, which the ship would have to reach before she became unstable. Under the assumed conditions with sails furled, there would have been little or no risk of her reaching such an inclination, the *Captain* having proved herself to be a well-behaved ship in a seaway.

Next take the case where sail is set, and the ship is acted upon by a *steady pressure of wind which in still water* would keep her at a steady angle of heel, say, of 10 degrees; this is within the truth, as it appears from the official reports that, on the day before

she was lost, the *Captain* heeled from 10 to 14 degrees under canvas. We have already discussed the case where the *Captain* is sailing at a steady heel of 10 degrees in still water, and Fig. 55 page 170, illustrates it. CD is the "wind curve," indicating the inclining effect of the wind on the sails for different angles of heel; and if by any means the vessel, which has been sailing at a heel of 10 degrees, is carried over to a greater inclination, the wind will follow, and always absorb that part of the area OCDPO of the curve of stability lying between the line CD and the axis of abscissæ (or "base-line") OP. It will be observed that the wind curve cuts the curve of stability at an inclination of 47 degrees, marked by the ordinate DD_1 ; so that the same force of wind that will steadily heel the ship 10 degrees will also hold her at 47 degrees, where she will be on the verge of capsizing. The effective range of the curve of stability, excluding the part absorbed by the steady force of wind, is therefore about 37 degrees only, that being the limit of inclination to the vertical which the ship can reach without being blown over when floating at mid-height on the wave. The decrease of 17 degrees from the total range, thus shown to be requisite to provide for the steady action of the wind is a very serious matter. Apart from gusts and squalls, there would still be a good provision for safety, taking into account the steadiness of the ship; but even ships reputed steady occasionally roll as much as this, and if the *Captain* had reached a position 10 degrees beyond that indicated in Fig. 72, she would have been on the point of capsizing. With steeper waves having a greater slope, the capsizing point would be sooner reached. In Mr. Childers' minute on the loss of the *Captain* (pages 56 and 57) will be found similar illustrations to the foregoing, only on waves of very exceptional steepness, 200 feet long, 23 feet high, and having a maximum slope of 20 degrees; then, supposing the *Captain* to be subjected to a steady wind capable of inclining her 8 degrees in still water, it is estimated that only 21 degrees inclination to the vertical would suffice to bring her to the verge of capsizing. Reverting to Fig. 55, and taking the case of the *Monarch* exposed to a force of wind equal to that assumed to act on the *Captain*, it will be seen that, after providing for the steady action of the wind, there remains an available range (KW) of over 55 degrees, instead of 37 degrees, as in the *Captain* under identical circumstances. From these two cases it will be evident that good range in the curve of stability is of the highest importance in rigged ships.

The greatest danger of capsizing results, not from the action

of a steady force of wind, but from that of gusts and squalls which may strike the sails of a ship, upon which considerable rolling motion has been impressed previously by the action of the wind or waves. At page 171 we have discussed the action of such gusts of wind upon sailing ships rolling in still water; similar but much more complicated conditions hold when a ship rolling among waves is caught by a squall at the extreme of a roll to windward. Various attempts have been made to deal with this difficult problem, and to enable the naval architect to form an opinion as to the ranges of stability sufficient in various classes of rigged ships. None of these attempts can be regarded as entirely successful, nor does the nature of the case permit of its solution by exact scientific investigation. Before such an investigation can be begun certain preliminary assumptions must be made: as to the sail-spread that shall be associated with a certain force of wind, the character of the waves amongst which the ship is placed, the inclination of the masts and their angular velocity at some instant, and the force of the squall as well as the position of the ship when struck. In short, some combination of circumstances has to be assumed as the worst likely to occur, in order that an opinion may be formed as to the probability of the ship capsizing or not. From this brief statement of the case, and bearing in mind what was said above as to the imperfect knowledge we possess of the laws governing wind pressure, it will be obvious that science has not yet enabled us to discuss with certainty the behaviour of sailing ships when rolling in a sea-way. The naval architect has, therefore, to resort to experience in order to appreciate fairly the influence of seamanship and the relative manageability of ships and sails of different sizes. Having before him the curves of stability of sailing ships of various classes, and the records of their performances at sea, the designer can proceed with greater assurance in the determination of the stability and sail-spread which shall be deemed sufficient in a new ship. A good range and large area of the curve of stability undoubtedly denote conditions which are very favourable to the safety of a ship against capsizing. But, in practice, such favourable conditions cannot always be secured in association with other important qualities, and a comparatively moderate range and area of curves of stability have to be considered when the question arises whether or not sufficient stability has been provided. Under these circumstances experience, and the analysis of the qualities of ships which have proved successful and safe, are of the greatest value.

Sailing ships of the mercantile marine and yachts usually have great range of stability when fully laden, for the reasons given in Chapter III. Rigged war-ships, on the other hand, frequently have moderate range of stability. So far as experience enables an opinion to be formed, it appears that in the smaller classes of seagoing war-ships with steam as well as sail-power, a range of 60 to 70 degrees in the curve of stability suffices for safety; in the larger classes, above corvettes, the corresponding range is about 70 to 80 degrees. It will be understood that these values are based upon experience, and they probably provide a reasonable margin of safety. The provision of a large range of stability cannot be regarded, however, as a guarantee against accident apart from proper management and good seamanship. Examples are not wanting of the truth of this statement, and one of the most forcible is that of the merchant sailing ship *Stuart Hahnemann*. Her curve of stability is marked 8 in Fig. 47e page 128; the angle of maximum stability exceeded 40 degrees, and the range exceeded 80 degrees. This vessel was thrown on her beam ends and sank: the Court of Inquiry found that she was well-built and perfectly equipped, her loss being attributed to the too long continued use of a heavy press of sail, so that when the wind increased the sail could not be taken in.

Although it is impossible in the present state of our knowledge to predict the worst possible combination of circumstances to which a sailing ship may be liable, it is possible to trace her behaviour, with fair approximation to accuracy, when a certain set of conditions has been selected. This can be done by means of an adaptation of the process of graphic integration to which reference was previously made. An example of the results obtained in this manner is given in Fig. 71b.

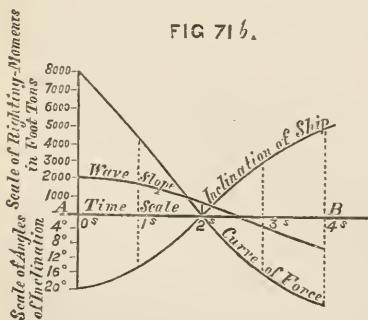

The general construction resembles that described for Fig. 71a. Measurements along the base-line represent *time*. Ordinates of the curve of "wave slope" represent the slope of the effective wave surface to the horizon at the corresponding time. At the instant from which time is counted, the ship is assumed to have her masts inclined 20

degrees to the windward side of the vertical, to float at the mid-

height of waves having a maximum slope of 9 degrees, and to have no angular motion. Her instantaneous inclination to the wave normal is therefore 29 degrees. It is then supposed that she is struck by a squall of wind, having such a force as would hold her at a steady heel of 10 degrees in still water. This suddenly-applied wind pressure follows her up as she rolls away to leeward, and at any instant the process of graphic integration takes account of the following forces as acting upon her:—(1) the moment of wind-pressure on the sails, corrected for the angular velocity (as described on page 245); (2) the moment of the resistance offered by the water to the motion of the ship; (3) the instantaneous righting moment, corrected for heaving. The resultant of these three moments at any instant appears as the ordinate of the “curve of force” in Fig. 71*b*; and the ordinate for the same instant of the curve of inclination shows the inclination of the masts to the vertical. Under these assumptions the vessel, which started from 20 degrees to windward, is driven over by the squall to 24 degrees to the leeward side of the vertical. If allowance were not made for the reduction in moment of wind pressure due to the motion of the sails away from the wind, then starting from the same inclination to windward the squall would drive the vessel over to 34 degrees to leeward. Further, were the effect of the fluid resistance neglected, the angle reached to leeward of the vertical would be 45 degrees. These figures are suggestive if not strictly accurate. They show how impossible it is to pronounce upon the maximum rolling of a ship without taking account of all the circumstances which may influence that behaviour.

Finally, on this part of the subject, reference must be made to the steadying effect which sail exercises upon a ship. This effect is a matter of common observation, and may be very simply explained. If a ship with sail set were rolling in a calm, the air would oppose great resistance to the oscillatory movement of the sails, and the rolling would be rapidly extinguished; this case is parallel to that described for water resistance in Chapter IV. When a ship is set rolling by the action of the sea, while the wind blows uniformly, it is difficult to estimate separately the effects of wind pressure and the air resistance to rolling. But when squalls or gusts of wind act intermittently on a vessel the influence of air resistance may become most important. Suppose, for example, the wind to lull when a ship has reached her extreme roll to leeward; then, on the return roll to windward, both air resistance and water resistance are tending to check the motion and lessen the extreme angle of roll to windward. So that if the

squall strikes her again in the most favourable position—the extreme of the roll to windward—it finds the ship much less inclined to the vertical than she would be if air resistance were not operative. The following lurch to leeward would consequently be much less heavy.

The longitudinal oscillations of pitching and 'scending experienced by ships among waves must be briefly considered before concluding this chapter. In still water such longitudinal oscillations do not occur under the conditions of actual service; and it is difficult, even for experimental purposes, to establish such oscillations, because of the great longitudinal stability of ships. On this account we have little definite information respecting still-water periods for pitching, or the "coefficients of resistance" for longitudinal oscillations. One or two small ships of shallow draught and full form have been experimented with; the period of longitudinal oscillation having been found to have been about three-fourths the period of transverse oscillation. Other observations made at sea appear to show that in many cases the period of pitching oscillations lies between one-half and two-thirds the period for rolling. In some cases it may fall as low as one-third the period for rolling; and in the Russian circular ships the two periods must be nearly equal.

The formula for the period of *unresisted* pitching may be expressed in the same form as that given on page 140 for the period of unresisted rolling. Only the height m must be made equal to the height of the longitudinal metacentre above the centre of gravity; and the radius of gyration k must be estimated by multiplying each element of weight by the square of its distance from the transverse axis passing through the centre of gravity. It may be taken for granted that, as a rule, the effect upon the period of the great height of the longitudinal metacentre above the centre of gravity of a ship more than counterbalances the effect of the increased moment of inertia for longitudinal oscillations; whence it follows that the period for pitching is usually considerably less than that for rolling. Calculations for the period of unresisted pitching have been made in a few instances; but they have little practical importance.

The existence of waves supplies a disturbing force capable of setting up the longitudinal oscillations; this is a matter of fact, and it is easily accounted for. Suppose a ship to be placed bow-on to an advancing wave; its slope will at the outset rise upon the foremost part of the ship above the water-level in still water;

and perhaps simultaneously at the after part of the ship the wave profile may fall below the still-water level. The obvious tendency of the bow will be to rise under the action of the surplus buoyancy at that part, the stern falling relatively; that is to say, a 'scending motion will be established, and its initial rate will depend upon the still-water period for longitudinal oscillations. After the wave crest has passed the bow of the ship, supposing for the instant that the wave is long as compared with the length of the ship, there will probably be a reversal of the conditions. The wave profile on the back slope of the wave would probably fall below the still-water load-line at the bow, and this excess of weight over buoyancy would tend to check 'scending and cause pitching to begin. The motion thus created by the passage of the first wave would of course be modified by the passage of succeeding waves in the series; and in the end there would probably be established a certain phase of pitching and 'scending oscillations, corresponding in character to the phases of rolling described above and largely influenced by the ratio of the apparent wave period to the natural period for still-water longitudinal oscillations.

This is the simplest case that can be chosen, and it by no means represents all the conditions of the problem; but it shows how the existence of waves and their passage past a ship lead to disturbances of the conditions of equilibrium existing in still water, and to the creation of accelerating forces due to the excess or defect of buoyancy. No account has here been taken of the variations in the direction and magnitude of the fluid pressure at different parts of the wave; although these variations would undoubtedly produce some modification in the behaviour of the ship, the modification would not be likely to change the *character* of the motion, with which alone we are at present concerned.

This illustration also shows that the following are the chief causes influencing the pitching and 'scending of ships: (1) the relative length of the waves and the ships; (2) the relation between the natural period (for longitudinal oscillations) of the ship and the apparent period of the waves, this apparent period being influenced by the course and speed of the ship in the manner previously explained; (3) the form of the wave profile, i.e. its steepness; (4) the form of the ship, especially near the bow and stern, in the neighbourhood of the still-water load-line, this form being influential in determining the amounts of the excesses or defects of buoyancy corresponding to the departure of the wave profile from coincidence with that line; (5) the longitudinal

distribution of the weights, determining the moment of inertia. In addition, it need hardly be said that fluid resistance exercises a most important influence in limiting the range of the oscillations; this resistance is governed by the form of the ship, and particularly by that of the extremities, where parts lying above the still-water load-line are immersed more or less as the ship pitches and 'scends, and therefore contribute to the resistance.

This summary requires but few comments. It is obvious, that, when the length of a ship is great as compared with the wave length, there is no probability of extensive pitching motions being produced. The *Great Eastern*, for example, with her length of 680 feet, could span from crest to crest even on the very large Atlantic storm waves observed by Dr. Scoresby; and on storm waves of common occurrence she might be floated simultaneously on three of them. Even less imposing structures, such as the largest ships of the Royal Navy, with lengths of 300 to 400 feet, are long as compared with ordinary storm waves, and therefore are not likely, as a rule, to accumulate large angles of pitching—a conclusion borne out by experience. Small vessels may, of course, fall in with waves which are long relatively to their own lengths; but in such cases it is a common observation that the vessels "float like ducks on the water"—that is to say, their natural periods for longitudinal oscillations are so small as compared with the wave period that they can very closely accompany the motions of those parts of the wave slope upon which they float. In fact, their condition furnishes a parallel to the case of the little raft in Fig. 62, except that the raft follows the upper surface of the wave, whereas the ship, stretching over a considerable length on the wave, and penetrating to some depth in it, does not follow the upper surface, but, as it were, averages the slope of a portion of a subsurface corresponding to her own length.

According to theory, the case of pitching is best dealt with in a manner similar to that adopted for rolling motions. The ship is supposed at every instant to have a tendency to move towards an instantaneous position of equilibrium which is a normal to her "effective wave slope"; but in the determination of this effective slope for longitudinal oscillations still greater difficulties are encountered than in the similar problem for rolling. One thing, however, is evident, even in the case where the length of the wave is great as compared with that of the ship, viz. that the steepness of the effective slope will be much less than the maximum slope of the upper surface, both because of the length along the wave which the ship occupies and of the depth to which she is immersed

in it. Supposing her to be in the worst position, with the middle of her length at the steepest inclination of the wave, the slope of the surface to the horizon, at the places occupied by the bow and stern, will be much less than the maximum slope; and, further, as remarked previously, all subsurface trochoids in the wave are less steep than the upper surface. The effective slope has to be the resultant of these varying conditions, and must therefore be much less steep than the maximum surface slope. But even accepting this conclusion, and assuming an effective slope, no practical deductions of importance have yet been drawn from this method of viewing the question, beyond those obtained from general considerations, and stated in the preceding summary.

It has been asserted that in large ships extreme pitching is not likely to occur; but it must be noted that even moderate angles of pitching lead to very considerable linear motions at the extremities of a long ship. For example, in the trials off Berehaven with the *Devastation*, *Agincourt*, and *Sultan*, it is reported that the *Sultan* on one occasion pitched so that the bow appeared buried very deeply in the wave, and observers on the deck of the *Devastation* could not determine whether the sea broke over the forecastle, which is some 30 feet above water when the ship is at rest in still water. Very similar remarks were made on another occasion respecting the *Agincourt*. For each degree of inclination from the upright, however, a point on the bow of the *Agincourt* would move vertically nearly 4 feet, and one on the bow of the *Sultan* about 3 feet; so that very moderate angles of inclination *in still water* would suffice to bring the forecastle deck close to the water-level. Amongst waves, with their varying slopes into which the bow of a ship plunges, much more moderate inclinations might produce the same apparent effect. For example, the *Devastation* and *Agincourt* were tried steaming head-on to waves from 400 to 650 feet long and from 20 to 26 feet high, the speed of the ships being about 7 knots per hour. The periods of these waves varied from 9 to 11 seconds; their maximum slopes, from $7\frac{1}{2}$ to 9 degrees. Allowing for the speed of the ships, the apparent periods of the waves varied from 7 to 9 seconds, giving apparent half-periods which probably approximated to equality with the natural period (for a single oscillation longitudinally) of the ships. It was a case, therefore, where the conditions were conducive to heavy pitching, and the results of the observations are interesting. The total arcs of oscillation for the *Devastation* were, on an average, 8 degrees only, that is, about 4 degrees on either side of the upright, or about one-half the maximum slope

of the surface of the waves; the maximum arc of oscillation was rather less than 12 degrees, about 6 degrees on either side of the upright, about three-fourths the maximum slope of the surface. The *Agincourt* pitched through rather smaller arcs than the *Devastation*, but, supposing her motion to have reached the same maximum, the bow would have been immersed in still water about 20 feet below its normal draught; yet we are assured that a sea broke over the forecastle, which is some 10 feet higher above still water, a circumstance which is attributable to the bow having been plunged into an advancing wave slope. These facts are mentioned in order to enforce the desirability of taking all possible precautions in estimating the extent of pitching; so many of the attendant circumstances tending to exaggerate the apparent motion, and to deceive the observer unless he has recourse to actual measurement of the angular motion.

From the foregoing remarks it will be evident that further progress in knowledge of the laws which govern pitching and 'scending must be largely dependent upon actual observations made at sea in a trustworthy manner. The Admiralty instructions provide for such observations when favourable opportunities present themselves; and this branch of the subject is one to which naval officers might devote attention with great advantage. As yet comparatively little information has been recorded; and of the published observations those made by M. Bertin are the most valuable.* With the aid of an ingeniously-contrived instrument (described in Chapter VII.) M. Bertin obtained simultaneous automatic records of (1) the instantaneous inclination of the ship to the vertical as she pitched; and (2) the instantaneous position of the normal to the effective wave slope. His conclusions from a careful analysis of these observations may be briefly stated. With a ship head to wind and sea, among waves of sufficient length relatively to the ship to produce sensible pitching motion, and within certain limits of the ratio of speed of ship to speed of wave, all the ships for which observations were made followed the effective wave-slope, just as the little raft in Fig. 62 follows the wave motion. Under these circumstances, as the speed was increased, but still fell within the assigned limit, the period for pitching was decreased, because this increase in speed shortened the apparent wave period; but the angle of pitching remained nearly constant. After this limit of speed had been surpassed the ships ceased to

* They are to be found in "*Observations avec l'oscillographe double à bord de divers batiments.*" Cherbourg, 1878.

follow the effective wave slope, their pitching motions falling behind instead of keeping pace with the effective slope. At certain speeds the motion of the ship dropped one-fourth of the period behind that of the effective slope; and then the pitching was found to have the same amplitude as in the case first described. Further increase in speed and still further decrease in the apparent wave period was found to produce much heavier pitching, and at length led to the bows of the ships being buried so deeply in the wave slopes that the experiments were stopped.

When the ships were running before the sea, and by their motion lengthening the apparent period of the waves, the case was found to be much simpler, the ships practically following the effective wave slopes. Hence, from a review of the whole of his observations, M. Bertin concludes that the best means of reducing pitching, in the critical case where a ship is driven head to sea, is to make her natural period of pitching as short as possible, by concentrating weights amidships, and reducing the moment of inertia. This conclusion, we need scarcely add, agrees with the recommendations made by experienced seamen. Nor need we dwell again upon the control over the behaviour of a ship which may be exercised by her commander by means of variations in speed and course relatively to the waves. But it may be proper to draw special attention to the fact that the actual period observed for pitching motions will vary considerably for the same ship under different circumstances, and usually differ considerably from the still-water period for longitudinal oscillations. Most commonly, so far as can be seen at present, the observed periods of pitching closely agree with the apparent periods of the waves which are large enough to produce considerable pitching motions.

The longitudinal distribution of the weights in a war-ship has to be regulated by other considerations than those mentioned above. It commonly happens that, to increase the offensive powers, heavy weights of guns, or armoured batteries, have to be carried near the extremities, thus adding to the moment of inertia, slowing the period of pitching, and rendering it probable that pitching oscillations will be more sustained, even if they are not made more extensive. All that can be done, in most cases, is to transport guns, anchors, or other relatively small weights from the extremities to some position more nearly amidships, when the vessel is making a voyage: these temporary changes are, of course, the work of the commanding officer and not of the designer. In merchant ships much more may be done towards

securing a longitudinal distribution of the cargo which favours moderate pitching, if proper care is taken in its stowage. Heavy weights, as a matter of common experience, should be kept out of the extremities; and where this simple rule is ignored extensive pitching and unnecessarily severe longitudinal straining have to be expected.

Fluid resistance is known to play an important part, as already stated, in limiting the range of pitching oscillations; but the naval architect has not the same control over this feature as he possesses in connection with rolling motions. It would be difficult to fit any appendages equivalent to bilge-keels in order to increase the resistance to longitudinal oscillations, although something may be done in this direction; and the under-water forms of ships are settled mainly with reference to their efficient propulsion, the effects of form on pitching usually occupying a subordinate place. Attempts have been made, however, to improve the forms of the bows of the ships in order to lessen pitching; and very diverse opinions have been expressed as to the best form that can be adopted. Many persons are in favour of **V**-shaped or "flaring" cross-sections; the out-of-water parts having a large volume as compared with the immersed part lying beneath them. Others have strongly objected to flaring bows, and have introduced **U**-shaped cross-sections, with the view of reducing pitching, as well as of reducing the excess of weight over buoyancy at the bow. The advocates of the **U**-shaped sections consider that "the bluff vertical sections encounter greater upward resistance than the **V**-shaped sections when the ship tends to plunge down through the water, and receive a greater lifting effect when the sea tends to rise up under the ship."* The adoption of pronounced **U**-shaped sections for the bow has not become general, nor does it appear likely to do so, other considerations leading most naval architects to prefer finer under-water forms; but the use of flaring sections above water is now less common than it was formerly, and naval architects agree that they are undesirable except in special cases, as, for example, where room is required at the bow to work a chase gun.

Vessels of low freeboard are subjected to deck resistance when pitching among waves; and the *Devastation* furnishes an excel-

* *Naval Science*, vol. iv., page 55. The reader may also consult on this subject a paper, by Dr. Woolley, "On

the Bows of the *Helicon* and *Salamis*," in vol. vii. of the *Transactions* of the Institution of Naval Architects.

lent example of this action. When on trial off the Irish coast, and steaming head to sea at moderate speeds, waves broke over the fore part of the deck, as it was anticipated they would do under these circumstances, the fittings on this deck having been designed to exclude from the interior water lodging upon it. An eye-witness, describing her motion, says:—"It invariably happened that the seas broke upon her during the upward journey of the bow; and there is no doubt that to this fact her moderate pitching was mainly due, as the weight of water on the fore-castle deck, during the short time it remained there, acted as a retarding force, preventing the bow from lifting as high as it otherwise would, and this, of course, limited the succeeding pitch, and so on." In American monitors, with their exceptionally small freeboard, this kind of action would be even more effective, were it not for the fact, that their natural periods for pitching oscillations are probably so small as to make them capable of accompanying very closely the motions of such waves as would produce considerable pitching in the monitors. Mr. Fox (assistant secretary of the United States navy), reporting on the behaviour of the *Miantonomoh*, head to sea in a heavy Atlantic storm, said, "She takes over about 4 feet of solid water, which is broken up as it sweeps along the deck, and after reaching the turret is too much spent to prevent firing the guns directly ahead." This confirms the opinion that these vessels move so quickly as to very nearly accompany the wave slope; their actual arcs of oscillation in pitching being considerable, and accurate practice with the guns in the line of keel being impossible. But these are cases of comparatively unfrequent occurrence, and are interesting chiefly as instances of the effect of fluid resistance in limiting the pitching motions of ships which immerse or emerge their decks. In ordinary ships the decks are much higher, and the longitudinal oscillations rarely acquire such a magnitude as to immerse the decks considerably.

Various proposals have been made for the purpose of increasing resistance to pitching. For instance, it has been suggested to fit horizontal side-keels near the extremities, or to broaden out the keel proper at those parts. At the bows of many recent armoured ships external supports are fitted to the projecting ram-bows; and these supports act as side-keels, which give increased resistance to pitching. The spur-bows themselves, prolonged under water as they are, also tend to reduce pitching by increasing resistance; and in the French navy, where this

form of bow has been largely adopted for unarmoured as well as for armoured ships, it is said that a sensible reduction in pitching has resulted. French naval architects, while favouring a form of bow which reaches forward for a considerable distance under water, prefer to make the stem fall aft considerably above water; their intention in the latter particular being to reduce the weight above water at the extremity at the same time that they either increase the buoyancy by the spur-bow or "fine" the under water form to facilitate propulsion.

In ships of ordinary form the maximum amplitude of rolling largely exceeds the corresponding maximum for pitching. M. Bertin considers that a fair ratio for these maxima is one (pitching) to six (rolling). We are not in possession of sufficient *data* to verify this estimate; but of the fact just stated there can be no doubt. Exceptions to this rule are to be found in the Russian circular ironclads and the *Livadia*. As the result of observations made on the latter in the Bay of Biscay, it appears that when placed head to sea she pitched through somewhat larger arcs than those she rolled through when broad-side-on to the waves. This departure from ordinary conditions is noteworthy.

CHAPTER VII.

METHODS OF OBSERVING THE ROLLING AND PITCHING MOTIONS
OF SHIPS.

ENOUGH has been said in previous pages to show how variable, and how liable to mislead an observer, are the conditions surrounding the behaviour of a ship at sea. The ship, herself in motion, is surrounded by water also in motion; and it is extremely difficult, by means of unaided personal observation, to determine even so apparently simple a matter as the position of the true vertical at any instant. To estimate correctly the angles through which a ship may be rolling or pitching, it is therefore necessary to bring apparatus of some kind into action; and in the use of such apparatus there are many sources of possible error which must be prevented from coming into operation. Upon the correctness of these observations we are greatly dependent, since deductions from theory are thus checked, and the extent to which they can be made a safe guide for the naval architect in designing new ships is ascertained. Numerous examples illustrating the substantial agreement of observation with the chief deductions from theory have been given in the previous chapter; but up to the present time the comparison has been mainly of a qualitative character, and before more exact results are obtained, it will be necessary to have compiled and collated much more exact and extensive records than are at present accessible.

The chief problem to be solved is this. What are the conditions of wave motion that will produce the maximum oscillation in a ship, of which the still-water period of oscillation as well as the coefficients of resistance are known; and what will be the range of that maximum oscillation? Or, it may be desirable to ascertain generally what extent of motion will be impressed upon

a ship by a series of waves of certain assumed dimensions. Pure theory will not be likely to supply correct answers to these questions; but there is reason to believe that they may be dealt with satisfactorily by a combination of the experimental and mathematical modes of investigation, such as the process of "graphic integration" described at page 237. The development of that process and its establishment in general use as a means of predicting the behaviour of ships, demand an extensive comparison of the results obtained by its application with the recorded observations of the behaviour of ships. Such a comparison can obviously be of use only when the individual observations are free from errors and accompanied by full particulars of the conditions of wind and sea. Methods of observing correctly the lengths, heights, and periods of waves have been described in detail in Chapter V.; and it is now proposed to sketch the methods which have been adopted at various times for observing the rolling and pitching oscillations of ships.

Of these methods, the following are the most important:—

- (1) The use of pendulums, with various forms of clinometers; these pendulums having periods of oscillation which are very short as compared with the periods of the ships.
- (2) The use of gyroscopic apparatus.
- (3) The use of "batten" instruments, or alternatives.
- (4) The use of automatic apparatus.

Taking these in the order they have been named, it may be well to glance at their chief features, and to indicate the probable correctness or otherwise of their records.

Pendulums, or clinometers, are the simplest instruments, but they are not trustworthy indicators of the angles of inclination attained by a ship when rolling in still water, and much less of those moved through by a ship rolling or pitching at sea. When a ship is held at a steady angle of heel (for example, as shown by Fig. 30), a pendulum suspended in her will hang vertically, no matter where its point of suspension may be placed, and will indicate the angle of heel correctly. The only force then acting upon the pendulum is its weight, *i.e.* the directive force of gravity, the line of action being vertical. But when, instead of being steadily inclined, the ship is made to oscillate in still water, she will turn about an axis, passing through or very near to the centre of gravity; hence every point not lying in the axis of rotation will be subjected to angular accelerations, similar to those which were described at page 135 for a simple

pendulum. Supposing the point of suspension of the clinometer to be either above or below the axis of rotation, it will be subjected to these accelerating forces, as well as to the directive force of gravity, and at each instant, instead of placing itself vertically, the clinometer, or pendulum, will tend to assume a position determined by the resultant of gravity and the accelerating force. If the period of the pendulum used is short as compared with the period of the ship, the position towards which it tends to move will probably be reached very nearly at each instant. The case is, in fact, similar to that represented in Fig. 71, page 225. If the length of the upper pendulum (AB) is supposed to represent the distance from the axis of rotation of the ship to the point of suspension of the pendulum which is intended to denote her inclinations, the clinometer pendulum may be represented by BC. As AB sways from side to side the point B is subjected to angular accelerations, and these must be compounded with gravity in order to determine the position which BC will assume; for obviously BC will no longer hang vertically. The angular accelerating force reaches its maximum when the extremity of an oscillation is reached, consequently it is at that position that the clinometer will depart furthest from the vertical position. In Fig. 71, suppose VAB to mark the extreme angle of inclination reached by the ship, and let AB be produced to D: then, to an observer on board, the angle CBD will represent the excess of the apparent inclination of the ship to the vertical above the true inclination.

It will be seen that the linear acceleration of the point of suspension B depends upon its distance from the axis of rotation A in Fig. 71. If B coincides with the axis of rotation, it is subjected to no accelerating forces, and a quick-moving pendulum hung very near to the height of the centre of gravity of a ship rolling in still water will, therefore, hang vertically, or nearly so, during the motion, indicating with very close approximation the true angles of inclination. Hence this valuable practical rule: when a ship is rolling in still water, if a pendulum is used to note the angles of inclination, it should be hung at the height of the centre of gravity of the ship; for if hung above that position it will indicate greater angles, and if hung below will indicate less angles, than are really rolled through; the error of the indications increasing with the distance of the point of suspension from the axis of rotation and the rapidity of the rolling motion of the ship.

The errors of the pendulum indications for still-water oscilla-

tions may be approximately estimated from the following formula, which was proposed by Mr. Froude :—

Let α = true angle of inclination reached by the ship ;
 β = apparent angle of inclination indicated by the pendulum ;
 T = period of oscillation (in seconds) for the ship ;
 h = the distance of the point of suspension of the pendulum above the centre of gravity of the ship :

Then
$$\alpha = \frac{3.27 T^2}{3.27 T^2 + h} \times \beta.$$

If, instead of 3.27, we write $3\frac{1}{3}$, this takes the approximate form,

$$\alpha = \frac{10 T^2}{10 T^2 + 3h} \times \beta,$$

which will be sufficiently near for practical purposes. In the case where the point of suspension is at a distance h below the centre of gravity the corresponding approximate formula is

$$\alpha = \frac{10 T^2}{10 T^2 - 3h} \times \beta.$$

Take one or two simple illustrative examples. For the *Prince Consort* $T = 5\frac{1}{2}$ seconds ; and h may be taken as 20 feet, if the pendulum were placed on the bridge :

Then
$$\frac{\alpha}{\beta} = \frac{10 T^2}{10 T^2 + 3h} = \frac{300}{300 + 60} = \frac{5}{6},$$

or
$$\alpha = \frac{5}{6} \beta ;$$

and the pendulum increases the true angle of heel by no less than 20 per cent. In the *Devastation* a pendulum placed on the flying deck may be taken as 25 feet above water ; also $T = 6\frac{3}{4}$ seconds.

Then
$$\frac{\alpha}{\beta} = \frac{10 \times (6\frac{3}{4})^2}{10 \times (6\frac{3}{4})^2 + 3 \times 25} = \frac{450}{450 + 75} = \frac{450}{525} = \frac{6}{7} ;$$

$$\alpha = \frac{6}{7} \beta.$$

Here the pendulum indications exaggerate the true angles of inclination by about 16 per cent. ; notwithstanding the greater height of the point of suspension above the centre of gravity, the slower motion of the *Devastation* makes the error smaller than in the *Prince Consort*.

So much for the simple case of still-water oscillations. When we turn to the more complicated case of a ship oscillating

amongst waves, there are good reasons for supposing that the errors of pendulum observations will be exaggerated. The centre of gravity of the ship is then, as explained in the preceding chapter, subjected to the action of horizontal and vertical accelerating forces. If the pendulum were hung at the centre of gravity (G) of the ship, shown on a wave in Fig. 62, page 185, it would, therefore, no longer maintain a truly vertical position during the oscillations, but would assume at each instant a position determined by the resultant of the accelerating forces impressed upon it and of gravity. The direction of this resultant has been shown to coincide with that of the corresponding normal to the effective wave slope. Hence follows another useful practical rule. When a ship is rolling amongst waves, a quick-moving pendulum suspended at the height of the centre of gravity will place itself normal to the effective wave slope, and its indications will mark the successive inclinations of the masts of the ship to that normal, not their inclinations to the true vertical. This distinction is a very important one. For example, in an American monitor, supposing her to keep her deck very nearly parallel to the wave slope as she might do, if a pendulum were hung close to the height of the centre of gravity, it would indicate little or no rolling motion; whereas the monitor would really be reaching inclinations equal to the maximum wave slope on each side of the vertical. On the other hand, if a steady ship, such as the *Inconstant*, were amongst the same waves, a pendulum hung at the centre of gravity would indicate extreme angles of inclination far in excess of the true rolling; for if the ship remained practically upright during the passage of the waves, the pendulum would indicate angles of inclination nearly equal to the effective wave slope.

When hung at any other height than at that of the centre of gravity of a ship rolling amongst waves, the indications of a pendulum are still less to be trusted. Referring to Fig. 73, three pendulums will be seen combined, viz. AB, to which hangs BC, and from this is suspended a third, CD. Supposing AB made to swing through a fixed range, it will represent the wave oscillation; then the motion of BC will represent the oscillations of a ship amongst the waves; and finally CD will represent the clinometer pendulum suspended at some point other than at the height of the centre of gravity of the ship. In view of what has been said above, it will be obvious that the motions of the pendu-

FIG 73.

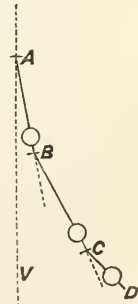

lum BC will not be indicated correctly by the pendulum CD; yet this is a parallel case to that when a pendulum or clinometer is trusted to indicate the angles of inclination to the vertical of a ship rolling amongst waves.

For a ship rolling among waves there is clearly no fixed axis of rotation, and the problem to be solved in discussing the possible errors of indication in a quick-moving pendulum hung at various heights in a ship is one of great difficulty. It would be out of place to introduce this discussion here; but reference may be made to some interesting observations with pendulums made by officers of the French navy. Admiral Bourgois made simultaneous observations of the rolling of the ironclad ship *Magenta*, in 1863, by correct batten observations of the horizon (such as are described hereafter) and by quick-moving pendulums hung in different vertical positions. In that ship he discovered that a quick-moving pendulum hung nearly at the height of the centre of buoyancy indicated practically correct angles of inclination to the vertical when the ship reached her extreme roll. Captain Mottez also made some similar experiments in the frigate *Sybilie* in 1865 when rolling heavily, and reached the following conclusions: that no possible point of suspension could be found where the indications of a pendulum were not influenced by the accelerating forces resulting from the rolling and heaving of the ship; but that the errors of indication were least when the pendulum was hung at about mid-draught. These results may not hold good in all cases, but they are of considerable practical interest, and may lead other observers to make similar experiments. It must always be an advantage to know where a pendulum may be placed in a ship so as to indicate with approximate correctness her angles of rolling, as circumstances may arise when only pendulum observations are possible.

Pendulums are commonly hung above water in ships, and under these circumstances their indications usually err in excess, and in some cases the error is proportionately very great, as the following examples will show. The figures are taken from published returns of rolling for her Majesty's ships:—

Ships.	Pendulum Indications.	Correct Angles.
	Degrees.	Degrees.
<i>Lord Warden</i>	11·4	9·1
<i>Minotaur</i>	6·1	3·8
"	8·2	4·3
<i>Bellerophon</i>	8·2	3

Many similar examples could be given, but they appear unnecessary; the correct angles stated in the table were observed in all cases with the accurate batten instruments which are now the service fitting.

The misleading character of pendulum observations has been for many years acknowledged; and they are no longer made in ships of the Royal Navy, except in special cases. When the horizon is obscured, or usually at night, batten observations cannot be made, while pendulum observations can; and it is ordered that under these circumstances the rolling indicated by the pendulums shall be noted. To enable the results so obtained to be afterwards corrected, simultaneous observations are made, when circumstances permit, of the indications of these same pendulums hung in the same positions, and of the indications of batten instruments.

In concluding these remarks on pendulum observations, it may be proper to add that any other devices, such as spirit-levels, mercurial clinometers, depending for their action on the directive force of gravity or statical conditions, are affected by the motion of a ship much as the pendulum has been shown to be affected. Suppose a spirit-level to be placed in a ship, at the height of the centre of gravity; in accordance with the principles previously explained, when its indications would lead an observer to think it exactly horizontal, it would really be parallel to the effective wave slope. Many persons who admit the faultiness of the pendulum are disposed to cling to the use of the level; but on reflection it will be seen that both instruments are open to similar objections. Moreover, the extreme sensitiveness and rapid motions of the spirit-level make it ill adapted for any observations in a seaway.

Several kinds of *gyroscopic instruments* have been devised for the purpose of measuring rolling and pitching motions, all of them being based upon the well-known principle—exemplified in the toy gyroscope—that a delicately balanced heavy-rimmed wheel spinning rapidly will maintain the plane of rotation in which it is set spinning, until its speed of rotation is considerably diminished. One of the earliest and best instruments of the kind is illustrated by Fig. 74. It was devised and tried at sea nearly twenty years ago by Professor Piazzi Smyth, Astronomer Royal of Scotland, and can be used to measure “yawing” motions as well as rolling and pitching.* It consists of a fly-wheel A,

See the description given by the inventor in vol. iv. of the *Transactions* of the Institution of Naval Architects, from which the drawing is taken.

the axis of which forms a diameter of the gymbal-ring B; this is carried by a second gymbal-ring, C, the pivots of which rest on the frame F; and the whole is mounted in an outer frame, enabling it to be easily carried or placed in position. Suppose the pivots of the ring C to be placed athwartships in a ship, the instrument standing on the deck or on a table: then for transverse oscillations the line-of-centres of the pivots will remain parallel to the deck—that is to say, so far as rolling is concerned

FIG. 74.

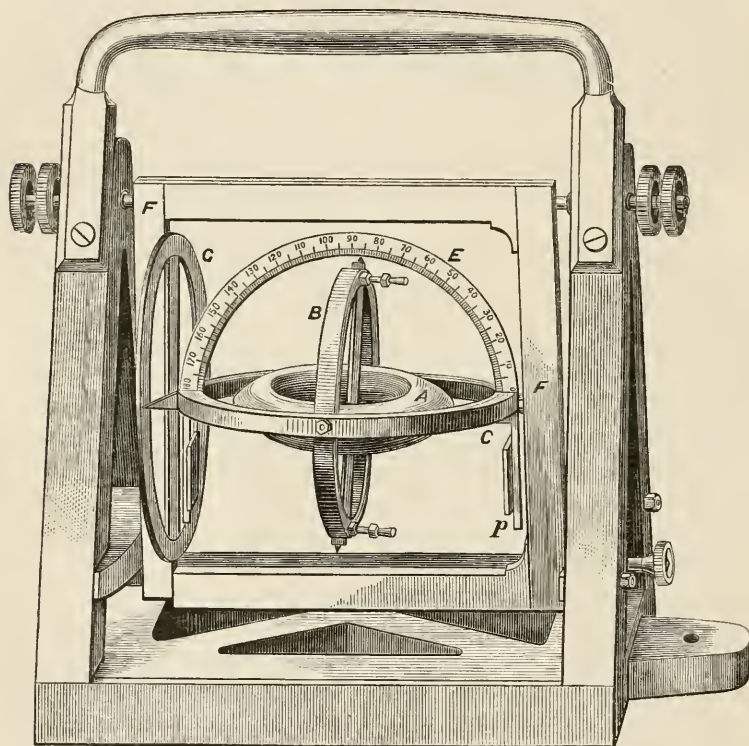

the ring C must move with the ship. But it is free to oscillate about its pivots as the ship pitches.

When the fly-wheel A is spinning rapidly and maintaining its plane of rotation, it is practically uninfluenced by the motions of the ship which so largely affect the pendulum; and as its axis is carried by the ring B, that ring also must maintain its position. This maintenance of position by B further involves the non-performance of any oscillations by C except in the *transverse* sense. In other words, neither A nor B changes the direction of its plane, while the ship rolls and pitches, so long as A spins

rapidly; while C can accompany the rolling motion, but not the pitching motion. Hence the graduated semicircle E, shown fixed upon and across C, moves relatively to B as the ship rolls; and the pointer attached to the upper edge of B sweeps over an arc on the semicircle equal to the arc through which the ship is oscillating. On the left-hand side of the diagram there is shown a graduated circle G, which has its centre coincident with one of the pivots of C, and is *fixed* to the frame F. As the ship pitches, therefore, the frame F moves with her, and oscillates about the ring C, which is prevented from accompanying the pitching in the manner described. Pointers marked *p* are attached to the under side of C, and the arcs they sweep over upon the graduated circle G indicate the arcs through which the ship pitches. By this ingenious arrangement the simultaneous rolling and pitching motions can be read off by observers with the greatest ease.

One point of disadvantage attaching to this as well as to all other gyroscopic instruments should, however, be noted; viz. that there is no separate indication of the angles of inclination attained on either side of the vertical. When the wheel A is set spinning, if it were truly horizontal, then B would be vertical, and this disadvantage would disappear. But a ship in a seaway changes its position rapidly, and it is practically impossible to secure this condition of initial horizontality; hence the observer must be content to note the *total arcs* of oscillation. No doubt, in most cases, the rolling of a ship not under sail approaches equal inclinations on either side of the vertical, the roll to leeward being somewhat in excess of that to windward; but in a ship under sail the rolling takes place about an inclined position, and in any case it is a great advantage to be able to ascertain the extreme inclination on either side of the vertical.

Professor Smyth fully appreciated this defect of all gyroscopic instruments, observing that they had "no power of determining absolute inclination, or angular position with reference to horizon or meridian;" but he was unacquainted with any other instrument which did not have its records affected by the accelerating forces due to the motion of the ship, and so preferred the gyroscopic clinometer. Now we have other means of measurement free from the objections belonging to pendulums or spirit-levels, and can therefore afford to dispense with the gyroscope.

It has been mentioned that the maintenance of the plane of rotation by a fly-wheel depends upon the maintenance of its speed; this is well illustrated in the common toy, which droops as the speed decreases. The practical difficulties attending the

use of these instruments arise, therefore, from the extreme care required in suspending the fly-wheels in order that friction or other causes may have the least effect in hindering free rotation, and in the difficulty of maintaining continuous rotation. The instrument shown in Fig. 74 is said to have been so well designed that, when once carefully adjusted, it did not require readjustment for some time ; but from the few records of its use that have been published, it would appear that Professor Smyth limited any single series of observations to a very brief period. When a considerable time is occupied in making the observations, there is a danger of the gyroscopic action being somewhat interfered with by the loss of speed of rotation.*

On this point some interesting facts have been stated by Admiral Paris, of the French navy, who produced a gyroscopic clinometer some years ago, which automatically recorded the rolling of a ship. The gyroscopic wheel in this instrument formed the body of a top, the lower end of the axis about which it spun being wrought to a sharp point, and resting on an agate bearing in order to diminish friction. To spin this top, a string was wound round the upper part of the axis, and drawn off gradually, giving a gradually accelerated motion of rotation. It was found that this top would revolve steadily on a support for about half an hour ; but nine minutes sufficed to degrade its revolutions from 23 per second to 12 per second ; and this lower speed sufficed to make the top steady enough to be used for recording the motion of a ship in a seaway ; the observations were usually extended over about ten minutes.

The automatic recording apparatus was extremely simple. As the ship rolled, the gyroscopic top maintained its axis in the same direction as that in which it was set spinning, and upon the upper end of the axis a camel-hair pencil saturated with ink was fixed. A sheet of paper was made, by means of clockwork, to travel longitudinally over the pencil point, being curved in the transverse sense, so that the point should just touch the paper as it swayed to and fro. The paper, with the arrangements by which it was made to travel, being attached to the ship, rolled with her, while the axis of the top maintained its original direction ; hence the pencil point traced out on the paper a curve showing the

* It may be interesting to add that, when the instrument illustrated in Fig. 74 was used to measure "yawing," it was placed with the pivots of the ring C in a vertical line; the frame

lying on its side instead of its bottom, and the wheel B being horizontal. The angles of "yawing" could then be read off on the graduated circle G.

inclinations of the ship at any instant on either side of the initial position of the pencil. The rate at which the clockwork propelled the sheet of paper being constant enabled the period of oscillation of the ship, as well as the arc of oscillation, to be read off from the diagram traced. Admiral Paris appears to have endeavoured to set the axis of his top truly vertical before commencing to record the motion, in order that the diagram might show inclinations to the vertical as well as arcs of oscillation; but in doing this, he must have encountered considerable difficulties, even if he was successful. We cannot further describe his ingenious arrangements, but would refer readers to the full details given in vol. viii. of the *Transactions* of the Institution of Naval Architects.

M. Normand has proposed an instrument for measuring rolling differing from the gyroscope in principle, but intended to effect a similar object, viz. the maintenance of an invariable plane, to which the motions of the ship could be referred. A spherical vessel is entirely filled with petroleum, and hung on double gymbal-rings like a compass. It contains a very light pendulum, situated at the centre of the sphere, and formed as a flat disc, carrying a pointer which stands at right angles to the disc. The inventor supposes that the fluid in the central parts of the sphere would have no angular motion set up in it by the reciprocating oscillations of the ship or the small oscillations of the sphere on its gymbal-rings, and that the pendulum would remain practically horizontal while the vessel rolled, its indicator being vertical. Much would obviously depend upon the position in the ship at which this instrument was placed. Supposing it to be at the centre of gravity, M. Normand's supposition might be nearly fulfilled, and the sphere with its contents would act like a common pendulum, its motions being governed by those of the effective wave slope, and keeping time with the wave period. Under these circumstances it is conceivable that the motions of the disc-pendulum might be small, and the motions of the ship might be fairly well indicated. But the use of any such instrument has never, we believe, found general favour; for general service simpler methods suffice, and for more scientific research it appears preferable to have recourse to a different principle, hereafter to be described, in order to secure the invariable vertical line of reference which M. Normand aimed at securing.*

* Drawings and descriptions of this instrument will be found in vol. vii. of the *Transactions* of the Institution of Naval Architects.

Batten instruments afford the simplest correct means of observing the oscillations of ships; they can be employed whenever the horizon can be sighted. The line of sight from the eye of an observer standing on the deck of a ship to the distant horizon will always remain practically horizontal during the motion of the ship. Consequently, if a certain position be chosen at which the eye of the observer will always be placed, and when the ship is upright and at rest, the horizontal line passing through that point is determined and marked in some way; this horizontal line can be used as a line of reference when the ship is rolling or pitching, and the angle it makes at any instant with the line of sight will indicate the inclination of her masts to the vertical.

This principle may be applied in different ways; one of the most common, generally adopted in the ships of the Royal Navy, is illustrated in Fig. 75. The point E on the middle line of the cross-section marks the position of the eye of the observer; and

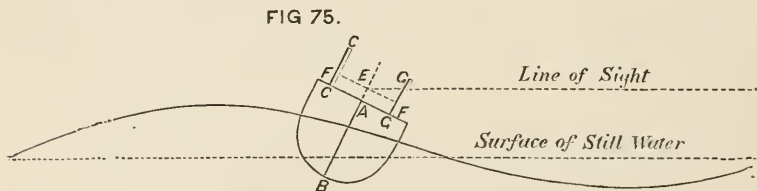

at equal distances athwartships, two battens CC and GG are fixed perpendicularly to the deck, so that, when the ship is upright and at rest, these battens are vertical, and at that time the line FEF will be horizontal. This line may be termed the “zero-line;” and the points FF would be marked upon the battens, being at a height above the deck, exceeding that of the point E by an amount determined by the transverse curvature or “round” of the deck. Suppose the diagram to represent the case of a ship rolling among waves; when she has reached the extreme of an oscillation to starboard, EG marks the line of sight to the horizon, and the angle GEF measures the angle of inclination of the masts to the vertical. If the battens are placed longitudinally, instead of transversely, the angular extent of pitching may be similarly measured. The angles are usually read off on that side of the point of observation E towards which the vessel is inclined; rolls to starboard being measured, for example, on the starboard battens, rolls to port on the port battens. Sometimes the inclinations to both port and starboard are read off on one

batten, above and below the zero. It is a great practical convenience to have the vertical battens graduated so that an observer can at once read off and note down the angles of inclination in degrees. This graduation is very simply effected when the positions of the battens relatively to E have been fixed, and the zero-line FEF determined. Once graduated, the battens can, of course, be removed when the observations are not in progress, and replaced in the same positions when required.

The zero-line on the battens having been fixed in the manner previously explained, the horizontal distance from the position where the eye of the observer will be placed to the vertical batten is measured; suppose this to be d feet, it will be indicated by EF in Figs. 75 and 76. Then, for any angle a , we have,

$$\left. \begin{array}{l} \text{Vertical height (FG) to be set off above} \\ \text{zero-line on batten} \end{array} \right\} = d \cdot \tan a.$$

The value of $\tan a$ being taken from a table, the product $d \tan a$ can be found. For instance, suppose $d = 20$ feet, and $a = 15$ degrees: $\tan a = 0.268$, and vertical distance (FG) to be set above zero-line will be $(20 \times 0.268) = 5.36$ feet.

Another form of the batten instrument is shown in Fig. 77. AB is a straight-edged batten pivoted at C, and carried

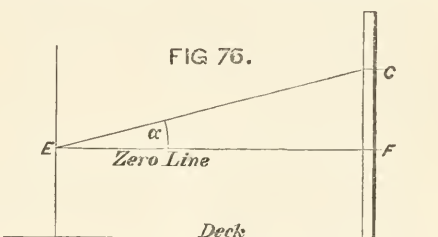

by a frame having attached to it a

semicircular graduated arc. Suppose that, when the ship is upright and at rest, the base of the instrument is so fixed that the pivoted bar, occupying the position AB, is horizontal. Then the line ACB marks the zero-line to which

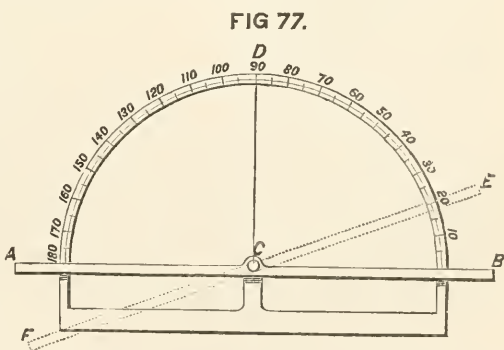

angles of inclination may be referred. The instrument may, if desired, be set transversely when rolling motions are being observed; the observer looking along the edge of the pivoted

batten will always keep it pointed to the horizon, and its motions can be observed on the graduated arc. For example, suppose the position FE to have been reached, then the angle ECB (a little over 20 degrees) will indicate the inclination of the masts of the ship to the vertical at that instant.*

Instead of looking lengthwise, and athwartships, along the edge of the batten when the instrument is set transversely, the observer may, if he prefers, stand before or abaft the instrument, and move the pivoted bar so as to keep its edge always parallel to the horizon; the angular motion of the bar indicated on the graduated arc will measure the inclination as before. To measure pitching, the instrument should be set longitudinally in the ship, the zero-line being adjusted as explained for rolling; and the observer will either look longitudinally along the edge of the batten, in order to keep it pointed to the horizon, or will stand and look athwartships, keeping the edge parallel to the horizon. In either case the angles of pitching may be read off from the graduated arc.

It will at once occur to the reader that the angular motions of such a pivoted bar might be readily made, by means of suitable mechanism attached to some point on the bar, to furnish an automatic record on a travelling sheet of paper moved at a uniform speed by clockwork. This has actually been done in some cases, a diagram being automatically traced, showing the inclinations of the ship throughout the period of observation. Hereafter the character of such mechanism will be illustrated, so that further description here is not required.

The proper conduct of observations with common batten instruments requires at least two observers: one to note the extreme angles of inclination attained by the ship, a second to note the periods of successive rolls. In the Royal Navy a single series of observations would last ten minutes, and during that time one observer would have to note the extreme inclinations for from seventy to, perhaps, one hundred and fifty or two hundred single rolls, according to the class of ship and character of the waves.† The other observer would, meanwhile, note the times of performing successive rolls, and the total number of rolls during the ten minutes. To complete the materials required for

* It will be evident that this instrument could also be used at night, when stars of known altitude were visible.

† To facilitate the entry of the particulars, printed forms are issued to the ships of the Royal Navy.

a discussion of the behaviour of the ship, the dimensions and periods of the waves ought to be observed simultaneously with the rolling or pitching; and this requires the attention of an independent set of observers, whose work should be conducted somewhat in the manner indicated in Chapter V. In large war-vessels with numerous complements it is easy to carry on such observations; in small vessels it is not always easy to provide for the working of the ship and to detail officers for observations of rolling and pitching. The most important observations are, however, those made in large ships of new types.

A very ingenious process for automatically making and recording horizon observations of rolling, by means of photography, has been devised by M. Huet of the French Navy, and successfully applied in several vessels. The apparatus consists of a camera fixed in the ship so that its axis is horizontal when the ship is upright. The field of the object lens is narrowed to a vertical slit, and a sheet of sensitive paper is made to travel parallel to the lens, by means of clockwork, at a uniform rate. On this sensitive paper a line is traced which would be in the same horizontal plane with the axis of the camera when the ship was upright, and this is taken as a line of reference. As the ship rolls the sensitive paper receives at each instant an impression of the sea and sky on the horizon; the colours being quite distinct; and their junction defining the instantaneous inclination of the ship to the vertical. Let d = the vertical distance of the junction of sea and sky shown on the paper at any instant, measured above or below the line of reference above named. Then, if f is the horizontal distance from the lens of the camera to the sensitive paper, and θ the angle of inclination of the ship to the vertical,

$$\tan \theta = \frac{d}{f}$$

is an equation determining the value of θ at every instant. The motion of the ship is, therefore, continuously recorded, and her inclinations at any time as well as her extreme angles of excursion can be ascertained. As an economiser of labour on the part of observers and an extension of the method of batten observations, this method is valuable. From specimens of the diagrams obtained on the sensitive paper which M. Huet has been good enough to furnish to the Author it also appears that the photographic records obtained are precise and easily interpreted. Independent observations of the wave phenomena ac-

companying rolling are necessary with this method, as well as with batten observations.

For all ordinary purposes batten observations of rolling and pitching, such as are made in the Royal Navy, suffice; but they require the simultaneous attention of at least two observers, and depend for their accuracy upon the care exercised by these officers. Moreover, they simply furnish the extreme inclinations attained by the ship, and the period-of her oscillation; and although these may be associated with simultaneous observations of the waves, there is no continuous record of the ratio of the angle of inclination of the ship to the angle of wave slope. More complete information, such as is most valuable for scientific purposes, can be best secured by means of automatic instruments, the records of which may be made continuously during prolonged periods. Such instruments require care both in their construction and management; but if they are based upon correct principles, they can be, and have been, made capable of far surpassing the results obtained by the most careful personal observation. Both in France and in this country such instruments have been made and used. M. Bertin, of Cherbourg, and the late Mr. W. Froude independently constructed instruments for this purpose, based upon very similar principles. That of Mr. Froude has been used on board the *Greyhound*, *Perseus*, and *Devastation* with great success, and a description of its leading features will be welcomed by all who take an interest in the subject of the behaviour of ships at sea, and may not have had the opportunity of consulting the descriptions which Mr. Froude published.*

Fig. 78 contains a general view of the instrument, mounted on a rocking platform, AAA, the motions of which represent those of the deck of a ship rolling in a seaway. The surface of the rocking platform to which the instrument is secured is shown at a considerable inclination, and the fixed frame upon which it rocks will be readily distinguished.

Two fundamental principles, already explained, may be again mentioned in order to facilitate explanation: (1) if a pendulum of very short period is hung at the height of the centre of gravity of a ship rolling among waves, it will at each instant stand practically normal to the effective wave slope; (2) if a pendulum of very long period be hung in the ship, it will remain practically

* For these see vol. xiv. of *Transactions* of the Institution of Naval Architects; from which most of the

particulars given in the text and the drawing of the instrument are taken.

vertical while she rolls. In the instrument there are two such pendulums; when the ship is upright and at rest, they both occupy a vertical position which is marked on some part of the apparatus that accompanies the motion of the ship. When the ship rolls, the oscillations of the quick-moving pendulum indicate the angles of inclination, at every instant, of the masts of the

FIG 78.

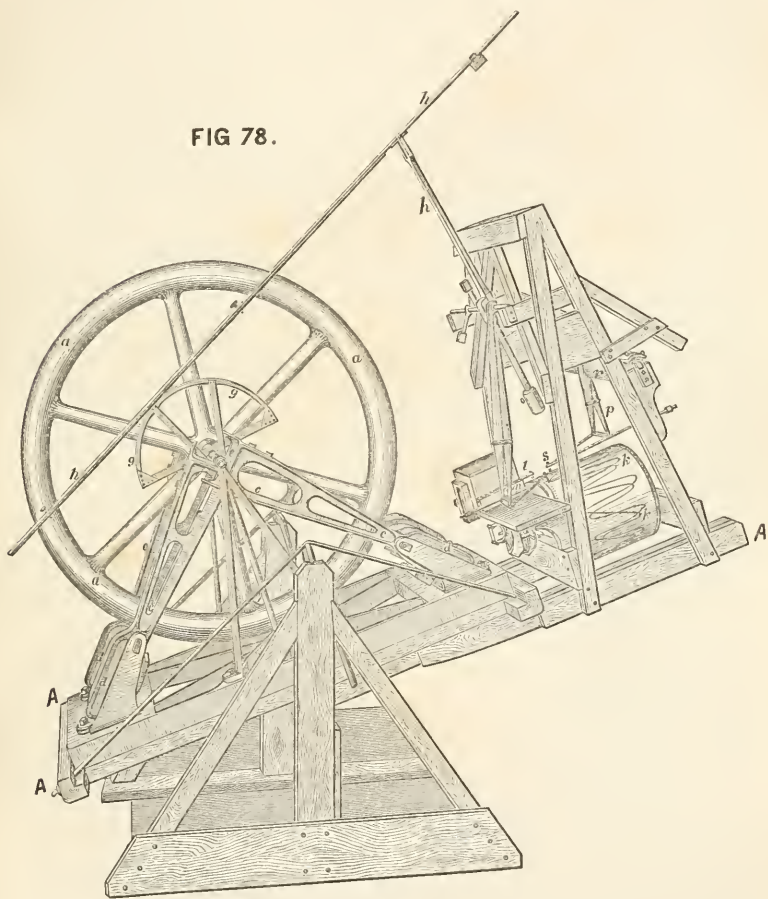

ship to the normal to the effective wave slope; while the oscillations of the very slow-moving pendulum indicate the simultaneous inclination of the masts to the vertical. From these two records the angles of wave slope at various times can be deduced, being the algebraical difference of the pendulum inclinations; and the profile of the effective wave surface can be constructed. In short, every important feature in the behaviour

of the ship is brought within the scope of analysis, by means of the diagrams automatically traced by the instrument.

The quick-moving pendulum is shown in Fig. 78 by *r* (on the right side of the drawing, and about mid-height on it). It consists of a horizontal brass tube, filled with lead so as to form a heavy bar-pendulum; this is suspended at each end on knife-edges, situated near the upper part of the circumference of the bar. The bar is only $2\frac{1}{2}$ inches in diameter, and about 20 inches long; so that the arrangement really produces a powerful and sensitive pendulum, of less than 2 inches in length, and consequently having a very short period.* It carries an arrangement of light arms (*p*), at the end of which is a pen, *s*; and as the bar-pendulum swings to and fro, the pen *s* registers the motion upon a sheet of paper carried by the cylinder *k*, which is driven by clockwork. The pen *s* traces on the paper a continuous line, and as the cylinder *k* revolves, another piece of clockwork *l* marks upon the paper a "scale of time;" so that the diagram produced shows not merely the successive inclinations of the ship to the effective surface, but also indicates the times at which those inclinations are attained. The interval of time marked by this scale, between two consecutive extremes of inclination, will show the "period" of the corresponding oscillation.

Considerable practical difficulties had to be overcome in constructing the second pendulum, which has a very long period. It consists of a heavy-rimmed wheel (*a*, in Fig. 78), 3 feet in diameter, weighing 200 lbs.; this is carried on an axis of steel, 1 inch in diameter, the centre of gravity of the whole being only six-thousandths (0.006) of an inch away from the centre of the axle. Here we see an arrangement identical in character with a ship having very little initial stability, but great inertia; the two contributing to produce a very long period. The observed time for a single swing of this wheel-pendulum, as it may be termed, has been found to be about 34 seconds; the magnitude of this period becomes evident when it is remembered that the slowest-moving ships have periods for a single roll of about 10 seconds only, and that the half-period of the largest waves commonly met with are still less. Friction rollers (*e, e*) support the steel axle; and the extreme delicacy of the suspension of this heavy wheel is attested, says Mr. Froude, "by the fact,

* A pendulum having a length of 2 inches has a period for a single roll of about two-tenths of a second only.

that, when at rest, a breath on the "circumference (of the wheel) will move it perceptibly." This wheel-pendulum continues almost unmoved as the ship rolls. The effects of any very small motion which the wheel may acquire are easily eliminated, and it practically indicates at every instant the true vertical direction, as well as the inclination thereto of the masts. This wheel is also made to record its motions on the revolving cylinder *k*. A wooden semi-circle *g* is carried on the axis, and by means of the light rods *h*, *h*—which are carefully counter-balanced—the relative angular motions of the ship and the steady wheel are made to move a pen, *m*, which draws a curve on the paper stretched upon the cylinder *k*. The character of this curve is similar to that traced by the pen *s*, moved by the pendulum *r*; and both these curves are indicated by the curved lines shown on the cylinder *k*, the rotary motion of the cylinder and the motion of the pens parallel to its axis combining to produce this result. The time scale is the same for both curves; and on that traced by the pen *m* the time interval between any two consecutive extremes of inclination measures the corresponding period of oscillation of the ship. When the observations are over, the paper can be removed from the cylinder *k*, and the diagrams drawn by the automatic apparatus can be analysed. Into this part of the work, however, it is unnecessary now to enter, our purpose being to give only a general sketch of the instrument. It furnishes the following information:—

(1) The relative inclination of the ship and the effective wave slope at any instant.

(2) The inclination of the ship to the vertical at any instant.

(3) The period of oscillation of the ship at any time—that is, the number of seconds occupied in completing the roll from port to starboard, or *vice versa*.

From 1 and 2 may also be deduced:—

(4) The angle of slope of the effective wave surface at any instant.

(5) The period of this effective wave, which will agree with the *apparent period* of the surface waves when the ship is floating among relatively large waves.

If, therefore, careful observations are made, while the instrument is at work, of the dimensions and periods of waves, the comparison between the observed slope of the surface wave and the deduced slope of the effective wave will furnish a test of the correctness of the ordinary assumptions as to the effective

wave slope. It will also enable future estimates of the probable rolling of ships to be made more precise than is now possible, owing to the doubts surrounding this question of the effective wave surface.*

In the instrument constructed by M. Bertin the heavy wheel-pendulum has a period, for a single swing, of 40 seconds: and the quick-moving pendulum a corresponding period of $\cdot 2$ second. Each pendulum automatically records its indications. M. Bertin has made several series of observations with this instrument, including pitching as well as rolling observations in his work, and the results obtained, as well as their analysis, constitute one of the most valuable additions made in recent years to the experimental study of the oscillations of ships.†

It may be worth notice, in passing, that the wheel-pendulum of either of these automatic instruments, stripped of its appliances for recording its indications, would constitute a very trustworthy substitute for the ordinary pendulums whose errors have been described (on page 265). Some simpler instrument embodying the same principles will probably yet come into general use as a substitute for the pendulum.

Before concluding this chapter, it may be well to repeat that, whatever method of observing the rolling or pitching may be adopted, the observations made cannot have their full value unless the attendant circumstances are fully recorded. For example, the *actual condition of the ship* at the time should be noted; whether she is under sail or steam; what portion of her consumable stores remain on board; whether the boilers are full or empty; whether there is anything unusual in her stowage; whether there is any water in the bilges; and any other features that would affect the still-water period of oscillation. Her *course* and *speed* should also be stated, the former being given relatively to the line of the wave advance, and the angle between the two being stated in degrees where possible. The dimensions and periods of the waves, both real and apparent, should also be carefully determined, as explained in Chapter V.

* Independently of the use of this instrument, naval officers might do much to add to existing knowledge on this point if they associated ordinary batten observations with simultaneous observations of the angles indicated by short pendulums hung at the height of the centre of gravity of the ship.

Great care would be required to ensure the simultaneity of the records of battens and pendulums if this plan were adopted.

† *Observations de roulis et de tangage faites avec l'oscillographe double*, par M. Bertin. See page 256 as to pitching.

Moreover, no change should be made affecting the behaviour of a ship for some time before the observations are commenced, nor during their progress; a change of course, an alteration in the sail spread, a change of speed, or any other changes, made immediately before the observations began, might seriously influence the behaviour during the comparatively short time over which a series of observations extends; and it is needless to point out the necessity for avoiding any changes during that short time. The Admiralty instructions enforce these conditions, providing that no change of course or speed, or spread of sail, &c., shall be made for at least ten minutes before the observations are commenced.

One of the most perfect sets of observations of the behaviour of a ship yet made were those conducted by the late Mr. Froude, on behalf of the Admiralty, on board the *Devastation*. But unfortunately for the scientific interest of the case, the weather encountered during the passage of that ship to the Mediterranean in 1875 was so moderate as neither to severely test her qualities nor to afford good opportunities for showing the full capabilities of the automatic instrument. Every naval officer proposing to enter upon similar work may read with advantage the brief report drawn up by Mr. Froude on the observations made during the passage.*

Ordinary observers have not similar advantages, but with the aid of the appliances in common use much valuable information has already been furnished, and it is to observations of a similar character we must look chiefly for still further facts bearing on the behaviour of ships at sea. An intelligent acquaintance with the main deductions from modern theory, as well as with the moot points of the subject, will enable the observer to supply much more valuable information, seeing that he will be capable of distinguishing the more important from the less important conditions, and of giving a practical direction to his inquiries.

* Published as *Parliamentary Paper* No. 104 of 1876.

CHAPTER VIII.

THE STRAINS EXPERIENCED BY SHIPS.

THE structure of a ship floating at rest in still water is usually subjected to various straining forces tending to produce changes of form; and when she is rolling and pitching in a seaway, or propelled by sails or steam-power, her structure is still more severely strained. In order to provide the necessary structural strength to resist these straining forces, the naval architect has to make choice of the materials best adapted for shipbuilding, and further to distribute and combine these materials so as most efficiently to resist changes of form or rupture of any part. By these means he seeks to secure the association of lightness with strength to the fullest possible extent, an object of which the importance has already been illustrated.* Before it can be accomplished satisfactorily, the designer of a ship must have an intelligent appreciation of the causes and character of the strains to be provided against; otherwise materials may be concentrated where strength is not chiefly required, or *vice versâ*. The importance of such knowledge has been recognised from the time when the construction of ships began to receive scientific treatment, but in this, as in most other branches of the subject, the greatest progress has been made within comparatively recent times. We now propose attempting a brief popular sketch of the chief straining actions to which ships are subjected, and in a subsequent chapter will discuss the principles of the structural strength of ships.

The chief strains to which ships are subjected may be classified as follows:—

(1) Strains tending to produce longitudinal bending—“hogging” or “sagging”—in the structure considered as a whole.

* See Chapter I. p. 3.

(2) Strains tending to alter the transverse form of a ship; *i.e.* to change the form of athwartship sections.

(3) Strains incidental to propulsion by steam or sails.

(4) Strains affecting particular parts of a ship—"local strains"—tending to produce local damage or change of form, independently of changes in the structure considered as a whole.

Besides these there are other strains, of less practical importance, which are interesting from a scientific point of view, but need not now be discussed, as there is ample strength in the structure of all ships to resist them, and there is no necessity in arranging the various parts to make special provision against such strains. Vertical *shearing forces*, for example, are in action in all ships; they tend to shear off the part of a ship lying before any cross-section from that abaft it; but no such separation of parts has been known to take place, nor is it likely to be accomplished in ordinary ships.

The order indicated in this classification is that which will be followed in our description, being the order of relative importance of the straining actions. All of them require consideration, but, while it is not difficult to provide against the last two classes, it is important to bestow careful attention on the prevention of changes of transverse form, and it is still more difficult to prevent longitudinal bending.

In passing, it may be well to remark that a distinction must be made between the *tendency* of any strain and its observed effect upon the structure of a ship. No visible change of form may result from the action of very severe strains, because the visible result of that action depends upon the strength and rigidity of the structure relatively to the strains brought upon it; nevertheless, the tendency of the straining forces is the same as if actual change of form was produced. For instance, it is very common to find wood ships "hogging" or "sagging" under the action of longitudinal bending strains; but iron ships, equally strained, have strength and rigidity so much in excess of wooden ships as to remain practically unchanged in form. Again, wood ships frequently "work," altering form transversely, when rolling in a seaway; and forces of equal intensity acting upon a stronger iron ship may give no external evidence of their existence. Yet in both cases the tendency of the straining forces is the same. This simple distinction is sometimes overlooked, and the absence of straining forces inferred from the maintenance of form.

Turning to the principal strains requiring consideration—those tending to produce longitudinal bending—the case to be first

considered is that of a ship floating at rest in still water. It has already been shown that there are two essential conditions of equilibrium: the ship must displace a quantity of water having a weight equal to her own weight, and her centre of gravity must be in the same vertical line with the centre of buoyancy. These two conditions may be fulfilled, however, and yet the weight and buoyancy may be very *unequally distributed*; the result being the production of longitudinal bending strains. As a very simple illustration, take Fig. 79, representing a ship floating at rest in still water. Supposing her to be divided by a

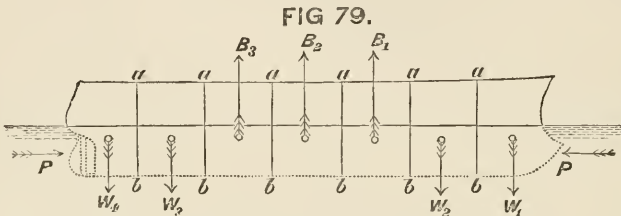

number of transverse vertical planes (*ab, ab, &c.*), let each piece of the ship between two consecutive planes of division be considered separately. At the bow there will probably be one or two portions for which the weight exceeds the buoyancy; these excesses of weight are indicated by W_1 and W_2 . Amidships the fuller form of the ship gives greater buoyancy to those subdivisions, and it is very common to find the buoyancy exceeding the weight, as indicated by B_1, B_2, B_3 , in the diagram. At the stern also the weight is likely to be in excess, as shown by W_3 and W_4 . The sum of these excesses of buoyancy will evidently balance the sum of the excesses of weight at the extremities; and the second hydrostatical condition of equilibrium

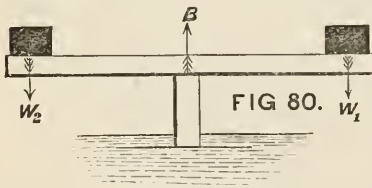

about any point shall be zero. It will be seen that a ship thus circumstanced is in a condition similar to that of the beam in Fig. 80, which is supported at the middle, and loaded at each end. Such a

beam tends to become curved, the ends dropping relatively to the middle, and the ends of the ship tend to drop similarly, the change of form being termed "hogging." Hogging strains are very commonly experienced at every part of the length of ships floating in still water.

If the conditions of Fig. 79 were reversed, the excesses of buoyancy occurring at the extremities, and those of weight amidships, the ship would resemble a beam supported at the ends and loaded at the middle of the length. The middle would then tend to drop relatively to the ends, a change of form sometimes occurring in ships, and known as "sagging." It is to be observed, however, that in all, or nearly all, ships, when floating in still water, the fine form of the extremities under water makes the buoyancy of those parts less than the corresponding weights; so that sagging strains are rarely experienced throughout the whole length of a ship in still water. Among waves, as will be seen hereafter, the conditions may be changed so as to produce sagging strains at every part of the length of a ship.

It is not uncommon to find the opinion expressed that, whenever there is an excess of weight amidships in a ship, sagging strains will be developed; but this is not a necessity. Suppose, for example, that Fig. 81 represents a vessel having an excess of

FIG 81.

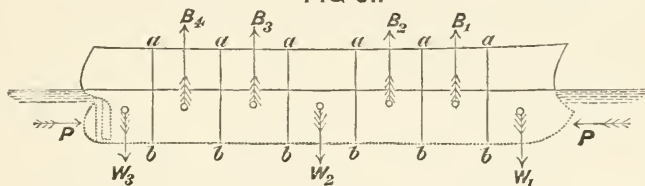

weight (W_2) amidships as well as at the extremities, and excesses of buoyancy at the intermediate portions. This is the condition of very many ships, such as paddle-steamers with their machinery concentrated in a comparatively small length amidships, or in ironclads with central armoured breastworks or batteries overlying the spaces occupied by the machinery. Such a vessel may be compared to the beam in

Fig. 82, supported at two points, and laden at the middle and ends. According to the view mentioned above, sagging strains should then be produced under the middle-load;

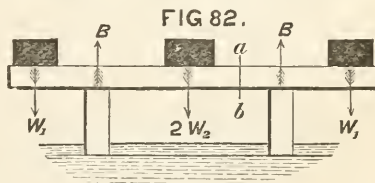

but it is easy to show that this may or may not be the case. For this purpose a short explanation is needed of a few simple principles, the application of which is general to ships as well as to beams.

Suppose it is desired to obtain the "bending moment" at any

section—say ab —of the beam in Fig. 82. Conceive the beam to be rigidly held at that section, and reckoning from either end of the beam up to ab , let an account be taken of every force acting upon it, load and support, as well as of the distance of the line of action of each force from the selected section ab . Multiply each force by the corresponding distance, add up separately the moments of the loads and supporting forces, and the differences of the two sums will be the bending moment required. It is immaterial which end is reckoned from in estimating the bending moment. As a very simple case, suppose it to be desired to find the bending moment of the forces acting upon the middle section of the beam in Fig. 82. Let the weight of the beam be neglected, and the supports be midway between the middle of the length and either end. Suppose the following values to be known:—

$4l$ = length of beam; W_1 = load on either end; $2W_2$ = load in middle.

Then each support will sustain a pressure (B) equal to $W_1 + W_2$. For the bending moment at the middle of the beam, we must have,

$$\text{Bending moment} = W_1 \times 2l - (W_1 + W_2)l = (W_1 - W_2)l.$$

Hence it will be seen that the following conditions hold:—

(a) If W_1 is greater than W_2 , there will be a *hogging* moment at the middle of the beam, and no section will be subjected to sagging moment, notwithstanding that the middle load $2W_2$ is carried.

(b) If W_1 is less than W_2 , there will be a sagging moment at the middle of the beam.

(c) Even in this second case the sections of the beam situated between the ends and the supports will be subjected to hogging moments, and so also will some part of the beam lying between the supports and the middle.

The case of the ship is similar, but more complex, the estimate of the bending moment experienced by the midship section involving the consideration of many vertical forces, some acting upwards and others downwards. But the foregoing is an illustration of the general mode of procedure; and the conditions of the existence or non-existence of sagging strains amidships stated for the beam are paralleled by somewhat similar conditions for the ship. Reckoning from the bow or stern of a ship to the midship section, or to any other cross-section, it is easy to estimate the bending moment when the relative distribution of the weight and

buoyancy for that vessel has been determined. But in such a determination lies the difficulty of practically applying the principles just explained.

The longitudinal distribution of the buoyancy of a ship is readily ascertainable from the calculations ordinarily made for her displacement; but the corresponding distribution of the weight can only be found by means of a laborious calculation. Until quite recently very little exact information on this subject was accessible; but the work since done at the Admiralty and at the Royal Naval College for various typical war-ships; as well as that done at Lloyd's Registry and by private shipbuilders for various classes of merchant ships, has added much valuable information, and enabled a more complete theory to be framed as to the conditions of strain to which ships are subjected.*

It is usual to represent the distribution of the weight and buoyancy of a ship by curves, similar to those shown in Fig. 83. A base-line (AB) is taken to represent the length of the ship, and at equidistant intervals ordinates are drawn to represent the hypothetical planes of division above described. Midway between any two ordinates a line is drawn perpendicular to the base-line, and upon this is set off a length representing, on a certain scale, the buoyancy of the length in the ship lying between the corresponding planes of division. A succession of points is thus obtained, and through these the "curve of buoyancy" (BBB) is drawn. The ordinary calculations for displacement afford a ready means of constructing this curve accurately.

To construct the curve of weight (WWW) is a matter of much greater difficulty. For each portion of the length in the ship lying between two planes of division it is necessary to calculate the weight of hull and lading in detail; when this is found, it is set off on the line drawn midway between the ordinates corresponding to the two planes of division, the scale for weight being the same as that previously chosen for buoyancy. When a series

* These calculations for war-ships were commenced under the direction of Sir Edward Reed, when Chief Constructor of the Navy, and have since been extensively made. The principal results of the earlier calculations, together with many generalisations therefrom, were published in part ii. of the *Philosophical Transactions* of the Royal Society for 1871. The Author had the

honour of assisting Sir Edward Reed in the preparation of this memoir, and the calculations upon which it was based; many of the facts stated in the text are drawn from the memoir. As to the strains of merchant ships, see papers in the *Transactions* of the Institution of Naval Architects for 1874, 1877, and 1881.

of points has been determined, and the curve of weight drawn, its total area must equal that of the curve of buoyancy, and the centres of gravity of the two areas must lie on the same ordinate ;

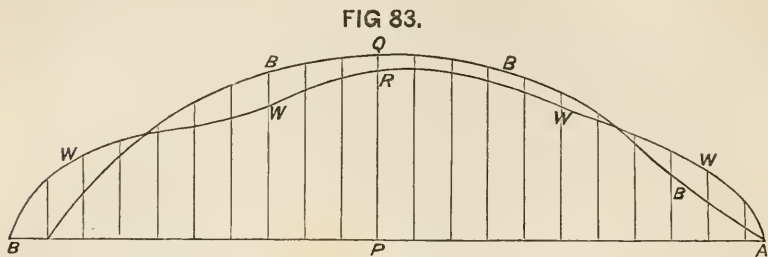

these conditions are only another form of statement for the two essential conditions of equilibrium for the ship floating at rest. Taking any ordinate (say PQ), the intercept (QR) between the two curves represents the excess (or defect) of buoyancy at that place. Where the curve of buoyancy lies outside the curve of weight (reckoning from the base-line AB), buoyancy is in excess ; where the curve of weight lies outside, the weight is in excess ; at the sections where the curves cross, the weight and buoyancy

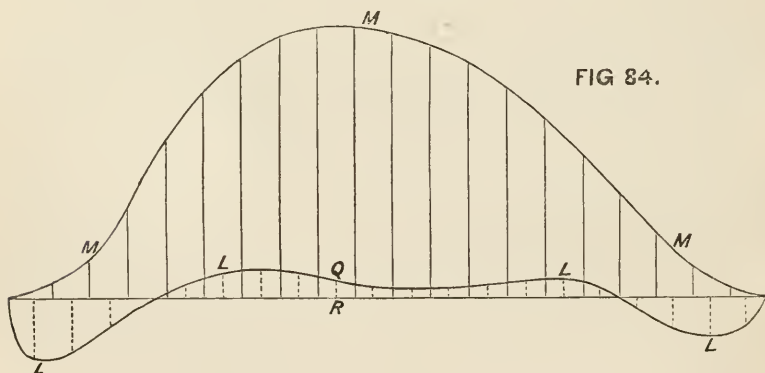

are equal, and these are termed "water-borne" sections. A more convenient mode of representing these excesses or defects of buoyancy is furnished in Fig. 84. Here the base-line and the dotted ordinates correspond to those in Fig. 83 ; and on any ordinate of those curves the intercept (say QR) is measured and transferred to the corresponding ordinate QR in Fig. 84, being set above the base-line AB when the buoyancy is in excess, and below when the weight is in excess. The curve LLL drawn through the points thus determined is termed the "curve of loads," and indi-

cates, at a glance, the unequal distribution of the weight and buoyancy.

The diagrams in Figs. 83 and 84 represent the case of Her Majesty's ship *Minotaur* (armour-plated frigate, 400 feet in length). She is a vessel completely protected by armour throughout her length from the upper deck down to some 6 feet under water; the finely formed ends are thus burdened with an excess of weight, the actual distribution of the weight and buoyancy being as follows:—

First 80 feet from the bow	Weight	420 tons in excess.
" 70 " " stern	"	450 " "
250 feet amidships	Buoyancy	870 " "

This vessel in still water furnishes, therefore, an example of the condition of the beam in Fig. 80. Hogging moments are experienced by all athwartship sections throughout the length, the maximum moment, at the midship section, being equal to the product of the total weight of the ship by $\frac{1}{88}$ of her length. The curve MMM in Fig. 84 indicates the variation in the bending moments from end to end of the ship; the length of any ordinate measuring the bending moment experienced by the corresponding cross-section in the ship. This curve of moments can be very easily constructed when the curve of loads has been drawn.

This is a very common case of the distribution of weight and buoyancy in ships; including the older types of sailing ships and many steam-ships. The excesses of weight at the extremities are, however, proportionately greater in an armoured vessel like the *Minotaur* than they are likely to be in unarmoured ships, and this exaggerates the maximum bending moment experienced by the midship section. It lies outside our present purpose to attempt any exhaustive statement of the varying conditions of weight and buoyancy either in ships of different classes or in the same ship when the weights are differently distributed. Attention must, however, be drawn to the facts, obvious enough from the preceding remarks, that the magnitude of bending strains in still water does not necessarily increase with deeper lading, and that for a given water-line and total displacement differences of stowage will greatly influence the strains. For example, if the armour were taken off the bow and stern of the *Minotaur* and stowed amidships, the excesses of weight at the extremities and of buoyancy amidships would be greatly reduced, causing a great reduction in the hogging moments at the midship section and

elsewhere. On the other hand, if the *Minotaur* floats light, with engines, boilers, and all equipment removed as for a general repair, the excesses of weight over buoyancy at the extremities and of buoyancy over weight amidships become much greater than they are in the fully laden condition. Instead of an excess of weight forward of 420 tons, there is, when light, an excess of 560 tons; while aft the excess increases from 450 to 500 tons; and amidships, on a length of some 230 feet, when the ship floats light, there is an excess of buoyancy of 1060 tons, as against 870 tons in the fully laden condition. The vessel is therefore subjected to much severer hogging strains when floating light in still water than she is when fully equipped. This is by no means an exceptional condition, and it explains the well-known fact that wood vessels often hog most soon after they are launched, or when lightened for thorough repairs. It was the practice formerly to place ballast on board ships lying in reserve in order to prevent hogging.

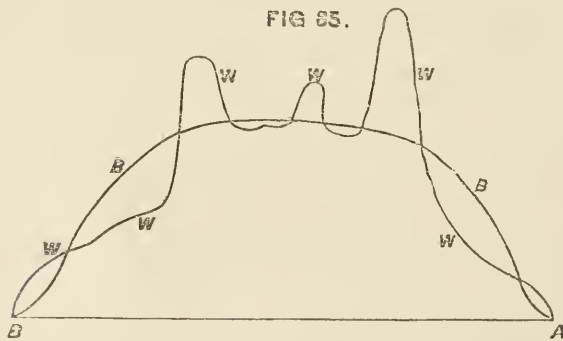

In the *Devastation* class of the Royal Navy, a far less simple distribution of the weight and buoyancy is found than that occurring in the *Minotaur* type. Figs. 85 and 86 illustrate this case. The spur-bow and full form forward, as well as the absence of high armoured ends in the *Devastation*, make the excess of weight very small, as compared with the *Minotaur*—about 60 tons excess only on the first 20 feet of length. Then follows about 57 feet of length, before the central breastwork, where buoyancy is in excess by about 520 tons; this is succeeded by a great excess of weight—550 tons on 32 feet of length—under the foremost turret. Along the central part of the ship, where the armoured breastwork is situated, and the machinery and boilers are placed, there is very nearly a balance of weight and buoyancy, the difference not amounting to more than 10 tons on a length of 75 feet, although,

as shown by the diagrams, there are two small excesses of buoyancy and one small excess of weight, the latter being due to the pilot-tower. Under the after turret, another large excess of weight occurs—320 tons on 38 feet of length; followed by a still larger excess of buoyancy—570 tons on a length of 63 feet; thence to the stern there is an excess of weight of 170 tons, owing to the fineness of the form of the ship in the run. These variations are indicated by the curves of weight (WWW) and buoyancy (BBB) in Fig. 85; but are more clearly shown by the curve of loads (LLL) in Fig. 86. The resultant bending moments are shown

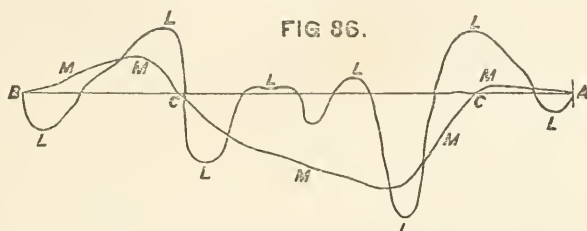

by the curve MMM, and offer a remarkable contrast to those for the *Minotaur* (see MMM, Fig. 84). For the first 50 feet from the bow there is scarcely any bending moment to be resisted in the *Devastation*; whereas in the *Minotaur* the moment at the corresponding part amounts to about 8000 foot-tons. At the after part also the hogging strains in the *Devastation* are very small, the greatest hogging moment being less than one-seventh as great as that in the *Minotaur*. But the most marked contrast is found amidships; the concentration of weight in the turrets of the *Devastation*, the absence of great excesses of weight at the ends, and the altered distribution of the excesses of buoyancy, develop sagging moments, indicated in Fig. 86 by the ordinates of the curve MMM being drawn *below* the base-line AB. The maximum bending strains are also made much more moderate. The maximum sagging strain in the *Devastation* is only a little over one-third the maximum hogging moment in the *Minotaur*; the exact figures are 15,300 foot-tons for the *Devastation* and 45,000 foot-tons for the *Minotaur*. Part of this reduction in bending moment is undoubtedly due to the less length of the *Devastation*; but expressing the maximum bending moment as a fraction of the product of the length by the displacement—which is the fairest method—it is about $\frac{1}{170}$ for the *Devastation* against $\frac{1}{85}$ for the *Minotaur*.

When the excesses of weight and buoyancy are differently

distributed in a ship having an excess of weight amidships, her condition may be intermediate between the two extremes already illustrated. The *Invincible* is an example of this intermediate class. When fully laden, there is an excess of weight of 115 tons on the first 35 feet from the bow, then an excess of buoyancy of 220 tons on a length of 65 feet; amidships, under the double-storied central battery, there is an excess of weight of 275 tons on a length of 80 feet; next an excess of buoyancy of 380 tons on a length of 70 feet, and on the last 30 feet of length to the stern an excess of weight of 210 tons. The result of this distribution of weight and buoyancy is to develop maximum hogging moments in the fore and after bodies, corresponding to those experienced by the *Devastation*; but at the midship section, instead of a sagging moment, there is a *minimum* value of the hogging moment, about one-third as great as the maximum bending moment experienced by the after body.

The foregoing illustrations have been taken from calculations made for war-ships, because the longitudinal distribution of the weights in those vessels is arranged by the designer, and is affected only by the consumption of coal, stores, &c. In merchant ships and especially in cargo-carrying ships there is no similar constancy in the longitudinal distribution of the weights; and the same ship may on different voyages be very differently laden, as well as subjected to very different strains. The shipbuilder has no control whatever over the stowage; and cases frequently occur where want of care and intelligence on the part of those charged with the stowage of cargo produces unnecessarily severe bending strains. As a basis for calculation and comparison of ship with ship, the assumption may not unfairly be made that a homogeneous cargo is carried which would fill the available spaces. Some small adjustments may be required in order to preserve the trim, but these are usually unimportant; as there can be no assurance that the strains resulting from this assumed stowage are the greatest likely to be brought upon the structure.

Summing up these remarks on the longitudinal bending strains produced by the unequal distribution of weight and buoyancy in ships floating at rest in still water, it will be seen that very considerable bending moments may be developed, the distribution of the weights very greatly affecting the amounts and character of the bending moments. Moreover, it is not always correct to say that the midship section sustains the greatest strain, cases occurring where there is a large excess of weight amidships, and yet the contrary is true—very little strain being brought upon the

midship section, and the greatest strain being experienced by some section in the fore or after body. These still-water strains are not nearly so severe as those experienced by a ship at sea; but they are, on the other hand, of constant occurrence, and may be termed the "permanent" strains on the structure. Hence considerable interest attaches to an investigation of their values, and there is the further advantage that the investigation leads up to the more important case of straining in a seaway.

Besides these vertical forces, a ship floating in still water has to resist longitudinal fluid pressures, tending to compress the lower part of the structure, and to produce longitudinal bending. Euler, and some of the other early writers on the subject, mentioned this fact, but they erred in their methods of estimating the effect of these pressures. In Figs. 79 and 81, PP indicate the pressures, which balance one another when the ship is at rest; their bending moment may be stated approximately as equal to the product of P into the distance of the "centre of pressure" of the immersed midship section below the middle of the depth of that section, reckoning that depth from the upper deck to the keel.* This moment is never absolutely great, but it sometimes assumes relative importance, especially in vessels with concentrated weights amidships. For example, in the central-battery ironclad *Bellerophon*, the vertical forces develop a very small bending moment, whereas the longitudinal fluid pressures produce a moment of over 3000 foot-tons—about *one-fourth* of the maximum hogging moment experienced by any cross-section of the ship when floating in still water. In the *Invincible* class, a nearly identical ratio holds between the moment due to the horizontal fluid pressures and the maximum hogging moment, which is experienced by a section in the after body, in consequence of the unequal distribution of weight and buoyancy previously particularised. This branch of the subject is, however, interesting rather than practically important.

Passing from the longitudinal bending strains experienced by ships in still water to those experienced when ships are at sea, it is evident that the latter strains must be far more severe and distressing to the structure. This arises principally from three causes. First, the existence of waves and the departures of the wave profiles from the level of still water will produce exaggerations

* More exactly, the distance of the centre of pressure should be reckoned from a point a little above the centre

of gravity of the sectional area of the parts on the midship section contributing resistance to bending.

in the inequality of distribution of the weight and buoyancy. Second, the rapid transit of waves past a ship will produce continual variations in the distribution of the buoyancy, these being necessarily accompanied by great and rapid changes in the character and intensity of the bending moments brought upon the structure. Third, the establishment of pitching and 'scending movements in the ship, as well as of vertical heaving motions, will lead to the development of accelerating forces tending to increase the strain upon the structure. It will, of course, be understood that we are still dealing with the longitudinal bending of the ship considered *as a whole*, and not with local strains such as may be produced by blows of the sea.

These general considerations are certain to command acceptance, but when an attempt is made to give them a more exact application, in order to determine the probable maximum strain which may be brought upon a ship exposed to the action of waves, difficulties arise of a very serious character. In fact, the best authorities agree in adopting a mode of treatment which has

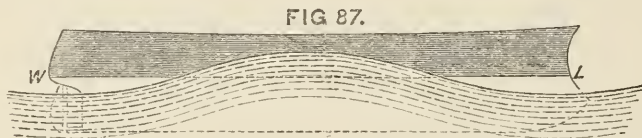

much to recommend it, although it by no means comprehends all the conditions of the problem, being rather a means of comparing the strains of different ships than of estimating the absolute maximum strain likely to be brought upon a particular vessel in a seaway. Two extreme cases are taken: one (illustrated by Fig. 87) where the ship is supposed to be upright and to rest instantaneously in statical equilibrium upon the crest of a wave having a length equal to her own; the other (see Fig. 88) where, in instantaneous equilibrium, she lies across the hollow of the

FIG 88.

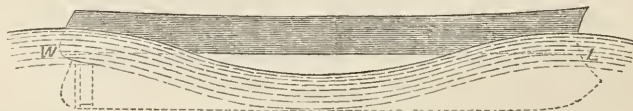

same wave, her bow and stern being at successive crests. The waves are assumed to have the steepness likely to be associated with their length; the ship is supposed to displace as much water on the waves as in still water; her centre of gravity is supposed

to be exactly over the centre of buoyancy corresponding to each of the extreme positions; and, instantaneously, she is treated just as if the wave delivered its pressure upon her vertically, much as still water does, the *form* of the displacement only being changed. Objections may, of course, be urged to all these assumptions; but, on the whole, they appear to embody the best method at present available for comparing the longitudinal bending strains of different classes of ships.

A glance at the diagrams shows how great a difference in the distribution of the buoyancy is produced by the passage of the wave; WL in each indicates the load water-line in still water. On the crest (see Fig. 87) the buoyancy at the extremities of the ship is decreased as compared with still water; the buoyancy amidships being considerably increased. In the hollow (see Fig. 88) the conditions are reversed; there is an increase of buoyancy at the bow and stern which sink into the wave deeper than the level of WL; while there is a decrease of buoyancy amidships. Speaking generally, it may be said, therefore, that all classes of ships supported on the crest of a wave of their own length tend to *hog throughout their length*, the greatest hogging moment being experienced either by the midship section or a section lying near to it. This is true even for vessels with concentrated central weights. On the other hand, in all except very few and unusual cases, ships astride a wave hollow (as in Fig. 88) have excesses of buoyancy at the ends and excesses of weight amidships; consequently they are subjected to *sagging moments throughout the length*,* the maximum bending moment being experienced at or near the midship section, even by ships which in still water tend to hog throughout the length.

A few facts for the *Minotaur* and *Devastation* will more clearly illustrate the foregoing statement. When the *Minotaur* floats on the crest of a wave 400 feet long and 25 feet high, the excesses of weight at the bow and stern become increased to 1275 and 1365 tons respectively—about *three times* as great as the corre-

* See the remarks made at page 285. Special features may produce small excesses of weight at the bow or stern even when they are immersed in the adjacent wave slopes. For example, in the *Minotaur*, on the wave of her own length mentioned in the text, the heavily armoured bow has a very small excess of weight, 10 tons on 10

feet; and in the *Devastation*, similarly circumstanced, the lowness of the free-board leads to the extremities of the deck being buried deep in the wave slopes, causing excesses of weight of about 25 and 65 tons respectively forward and aft. But these may be safely neglected, since the resultant hogging moments are very small.

sponding excesses in still water; the excess of buoyancy amidships being no less than 2640 tons. The maximum hogging moment borne by the midship section is 140,000 foot-tons—more than three times the maximum hogging moment experienced in still water. These exaggerations of strain, however, leave the character of the strain unaltered, every transverse section being subjected to a hogging moment as in still water.

Astride the wave hollow, the ship is subjected to entirely different conditions; at both bow and stern there is an excess of buoyancy of about 690 tons, and amidships an excess of weight of 1380 tons. Throughout the length sagging strains have to be resisted; and the maximum sagging moment, borne by a transverse section near the middle of the length, is about 74,800 foot-tons.

Ships of the *Devastation* type gain upon the *Minotaur* class when placed upon the wave crest, because the added buoyancy amidships is well situated in relation to the concentrated weights there placed. Hogging moments are then experienced throughout the length, but they are of moderate amount as compared with those for the *Minotaur* type. When the *Devastation* floats on a wave of her own length (300 feet by 20 feet high)—a proportionately steeper wave than that assumed for the *Minotaur*—the weight and buoyancy are distributed as follows. First 37 feet from the bow, weight 130 tons in excess; next 34 feet, buoyancy 90 tons in excess; next 35 feet (under fore turret), weight 580 tons in excess; next 84 feet (in wake of wave crest), buoyancy 940 tons in excess; next 22 feet, weight (under after turret) 160 tons in excess; next 37 feet, buoyancy 260 tons in excess; and thence to the stern, weight 420 tons in excess. This case is more complicated than that of the *Minotaur* type, just as it has been shown to be in still water. But the resultant bending moments are far less severe; the maximum hogging moment amidships in the *Devastation* is only one-fourth (36,800 foot-tons) that in the *Minotaur*.

The most critical case for the *Devastation* type is that when the ship lies astride a wave hollow, as in Fig. 88. The substitution of the wave profile for the horizontal surface of still water exaggerates the excesses of weight amidships, while the immersion of the extremities in the wave slopes decreases or does away with any excess of weight existing there in still water. The lowness of the freeboard in the *Devastation* helps the ship in this critical position; the wave slopes cover the extremities of the upper deck, the ship sinking bodily deeper into the wave than if she

had a lofty bow and stern like the *Minotaur*; consequently there are less excesses of buoyancy at the extremities, as well as less sagging moments amidships. The actual distribution of the weight and buoyancy in this position may be summarised as follows. The first 80 feet of length from the bow, buoyancy, 920 tons in excess; the first 95 feet of length from the stern buoyancy 880 tons in excess; on the midship length of about 135 feet, weight 1800 tons in excess. These are considerable quantities, but compared with the corresponding figures for the *Minotaur* on a wave crest, they appear moderate. The resultant maximum sagging moments in the *Devastation*, experienced by a section near the middle of the length, is 51,000 foot-tons; about *two-thirds* the corresponding sagging moment for the *Minotaur*, and a little over *one-third* the maximum hogging moment for that ship.

It has been previously remarked that the fairest comparison is that which expresses the bending moments as a fraction of the product of the weight (W tons) into the length (L feet). As a summary of the foregoing remarks the following table is given.

Maximum Bending Moment.	<i>Minotaur.</i>	<i>Devastation.</i>
On wave crest—hogging	$\frac{1}{28} \times W \times L$	$\frac{1}{71} \times W \times L$
In wave hollow—sagging	$\frac{1}{53} \times W \times L$	$\frac{1}{151} \times W \times L$
In still water	$\frac{1}{88} \times W \times L$ (Hogging)	$\frac{1}{70} \times W \times L$ (Sagging)

Allusion has been made to the great rapidity and magnitude of the changes of strain to which ships are liable in a seaway, and the statement may now be illustrated. From the time that the *Minotaur* occupies the position shown in Fig. 87 to the instant when she may lie across the hollow as in Fig. 88 will be an interval of only $4\frac{1}{2}$ seconds; the straining actions at the commencement of that brief interval tend to hog the ship with a moment of 140,000 foot-tons, while at its end their character has undergone a complete change, and they produce a sagging moment of 74,800 foot-tons. The sum of these quantities—say 215,000 foot-tons—may be taken as a measure of the change of bending moment occurring about once in every $4\frac{1}{2}$ seconds. In the *Devastation*, owing to her less length, the time interval between the two extreme positions will be less than 4 seconds; the bending moment changing from 37,000 foot-tons (hogging) to 51,000 foot-tons (sagging), the

sum of the two being about 88,000 foot-tons, or considerably below one-half the corresponding sum in the *Minotaur*. As between the two ships, the difference is very important; but it will be understood that the present intention is rather to deal with types and general principles than with particular ships. These principles apply, moreover, with equal force to unarmoured vessels of war or to non-combatant vessels.

In the following table have been grouped the results of a number of calculations for the bending moments of different classes of ships. The waves assumed in each case have had lengths equal to the lengths of the ships; but it will be observed that the ratio of heights to lengths of waves differ considerably in the various examples, thus rendering an exact comparison impossible. Apart from such a comparison, however, the figures will have an interest as illustrations of the singular differences existing between the character and magnitude of the still-water bending moments of various types of ships, and the contrast between those still-water strains for a particular ship, and the strains on a wave crest, or astride a wave hollow. So far as calculations have yet been carried, the types represented by the *Minotaur* and the *Victoria and Albert* lie at opposite extremes amongst sea-going ships, the one having an exceptionally high hogging moment on a wave crest, while the other sustains a very large sagging moment when astride a wave hollow. Proportionately higher bending moments are mentioned for the light-draught merchant steamer in the table; but that vessel was built for river service, and was simply making a passage out to her station when she failed under the strains recorded against her name. For sea-going ships, so far as can be seen at present, the maximum bending moment (in foot-tons) is likely to fall below *one-twentieth* of the product of the weight of the ship into her length, if the ratio of height to length assumed for the waves does not exceed 1 to 15. Cases may be met with where the maximum bending moment, estimated in the manner described, may exceed the limit named, because of some exceptionally trying distribution of the load; and it is obviously very difficult to assign the worst possible conditions of lading to any merchant ship.

It will be evident that changes in the ratio of the height to the length of the waves, upon which a given ship is supposed to float, will produce corresponding changes in the bending moments. Taking, for example, the position illustrated by Fig. 87, it will be evident that an increase in the height and steepness of the waves

Name of Ship.	Description of Ship.	Waves Assumed in Calculations.			Maximum Bending Moment = Weight × Length ÷ the numbers below.			Authority.
		Length.		Height.	Still Water.	Wave Crest.	Wave Hollow.	
		Feet.	Feet.					
Armoured ships:—								
<i>Bellerophon</i>	Frigate with water-line belt, and central main-deck battery.	300	20	176	48.5	43	Sir E. J. Reed.	
—	{ Frigate with water-line belt, and two-storied central battery (Invincible type) }	280	18	227	70	38	The Author.	
—	{ Turret-ran: single turret in battery (Rapier type) }	256	17	263	43	41	"	
—	{ Belted cruiser; with armoured screens to chase guns (Shannon type) }	270	18	121	33	67	"	
—	{ Central citadel, with under-water deck at extremities (Ajax type) }	300	18	79	146	30	"	
Unarmoured ships:—								
<i>Iris</i>	Steel twin-screw despatch vessel, lightly armed, high speed.	300	15	58	29	..	"	
<i>Victoria and Albert</i>	Royal yacht: paddle-wheel steamer of high speed	300	20	139	43	23	Sir E. J. Reed.	
—	Second-class torpedo-boat	1060	Mr. Thornycroft.	
Merchant steamers:—								
—	Sea-going cargo-carrier { at light draught }	336	12	..	35	50	Mr. John.	
—	Sea-going cargo-carrier { at deep draught }	360	16	117	26	33	Mr. Rundell.	
—	{ Sea-going awning-decked cargo and passenger (homogeneous cargo) }	360	16	109	37	83	"	
—	{ Light-draught river steamer, making a passage }	360	18	158	37	43	The Author.	
<i>Mary</i>	Light-draught river steamer, making a passage	210	7	70	37	17	Mr. John.	

NOTE.—The negative sign in the column for still-water bending indicates a sagging moment; in all other cases for still-water hogging moments are experienced. On the wave crests hogging moments are universal; on the wave hollow sagging moments.

is likely to be accompanied by an increase in the hogging moment. In comparing ships, therefore, it is important to treat them similarly as regards the character of the waves assumed in making estimates for the bending moments. From the facts set forth at page 196 as to the ratios of height to length in waves, it appears that the following values of that ratio may be accepted as fair averages in calculations of strains :

For ships below 300 feet in length . . . 1 : 20.

For ships above 300 feet in length . . . 1 : 25.

Greater ratios of height to length may occur, as before stated, but they are of much less frequent occurrence than the average ratios recommended for use.

All the foregoing estimates of the relative distribution of the weight and buoyancy have been made on the supposition that the ship is upright; but it commonly happens that, in a seaway, a vessel rolls through large angles, while subjected to longitudinal bending strains. Such inclinations from the upright necessarily affect the distribution of the buoyancy along the length, and without actual calculation it is not possible to ascertain how these changes may affect the bending moments. It is, however, worthy of note that the hypothetical cases in Figs. 87 and 88 represent a ship bow-on to the waves; the position in which she is likely to roll comparatively little. On the other hand, if she is broad-side-on, or nearly so, to the waves, and rolls considerably in consequence, the wave form occupies a position relatively to her length far less likely to cause such unequal distribution of the weight and buoyancy as is assumed in Figs. 87 and 88. When the ship lies obliquely to the waves, another kind of strain is developed concurrently with longitudinal bending; viz. the *twisting* tendency, produced when the bow is lying on the slope of one wave and the stern on that of the next wave, the fore and after parts of the ship being subject to forces tending to heel them in opposite directions. But all these are matters which should influence the structural arrangements in a degree subordinate to that of the considerations which have received most attention in this chapter; and they are mentioned here chiefly because in the following chapter some notice will be taken of the manner in which the shipbuilder provides strength to resist them.

Although in the accepted method for comparing the longitudinal bending moments of ships no attempt is made to estimate the effects of the accelerating forces incidental to the heaving and

pitching motions impressed upon ships by waves, the possible importance of these effects is not overlooked. Mathematical equations may be formed expressing the magnitude of the strains produced at any instant by pitching; but they include so many quantities which are unknown, or only partly known, that exact estimates cannot be based upon them. Certain fundamental principles may, however, be mentioned. The accelerating forces attain their maximum value when a ship reaches the extreme of a pitching oscillation, and is for the instant at rest. Their effect may be simply expressed by the statement that they tend to make the extremities of the ship go on moving in the direction in which they were moving before the motion ceased. For example, the bow of a ship moves downwards when pitching, and when the extreme of the pitch has been reached the accelerating forces tend to make the downward motion continue; that is to say, having regard to the longitudinal distribution of the fluid resistance which stops the downward motion, those forces usually tend to produce hogging strains in the fore part of the ship. The magnitude of the accelerating forces increases as the amplitude of the oscillation increases, and as the period of oscillation decreases. A quick-moving ship is likely to be more strained in pitching than a slow-moving ship for a given amplitude of oscillation; and it will be remembered that when the slow motion is accompanied by increase in size, the amplitude of pitching is likely to be decreased (see remarks on page 254). Nor does it suffice to consider only the influence of the accelerating forces upon the bending moments when a ship is pitching among waves. The longitudinal oscillation gives rise to a variation in the distribution of the weight and buoyancy additional to that produced by the passage of the wave profiles. At one instant the bow may be buried deeply in the wave slope, and soon after it may be almost out of water, the immersion and emersion depending upon the relation between the wave motion and the longitudinal oscillations of the ship. Furthermore at every instant except when the extremes of an oscillation are reached, the fluid resistance to pitching brings into play upon the ship reactions which must sensibly affect the bending moment. And finally the heaving motion which accompanies the pitching must cause variations in the bending moment by causing variations in the "virtual weight" (see page 186). This summary of the difficulties in the way of an exact solution of the problem is not put forward as a reason why further attempts should not be made at its solution; but simply as an indication of the reasons which have led to the

adoption of a method of comparison based upon a statical hypothesis and confessedly imperfect.

The best authorities at present agree in taking the exceptional positions illustrated in Figs. 87 and 88 as affording fair comparative measures of the maximum longitudinal bending strains experienced by ships. Some writers, including the late Sir W. Fairbairn, have, however, suggested the propriety of giving to all ships strength sufficient to resist the far more severe bending strains produced when vessels are aground and supported only at the middle of the length, or at the ends. The advantage of adopting such a standard may well be questioned, seeing that the theoretical conditions of support—viz. concentration of the support at *points* along the length—are never likely to be fulfilled, and rarely, if ever, approximated to. Many ships have grounded, no doubt, and rested either at the middle part only or else only at the ends; but a certain distribution of the support has even then been secured, and in nearly all such cases the vessels have remained partially water-borne. Moreover, accidents of this kind are of rare occurrence to any ship, and are entirely escaped by the great majority of vessels; besides which it must be remembered that failure or serious damage in grounding, &c., is far more likely to result from excessive *local* strains than from bending strains experienced by the ship as a whole. The bottoms of ships crush up, or are much damaged, very frequently before the structural strength against bending strains is over-tasked. On the whole, therefore, the generally accepted method which deals with ships *afloat* appears very much superior to the alternative proposal, based upon the condition of ships ashore. There are a vast number of ships which have been many years afloat on active service, and have displayed no signs of weakness, which would utterly fail under the conditions which Sir W. Fairbairn and others would have imposed; for it appears that, in the extreme cases of support ashore, the maximum bending strains reach from four to six times the maximum strains incidental to the extreme cases of support amongst waves. In some of these vessels, no doubt, the best distribution of material has not been made, and much greater longitudinal strength might be secured by improved arrangements without increase in the total weights of hull; but in most cases it would appear an unnecessary and uneconomical plan to provide a large reserve of strength to meet a contingency that may never be encountered, and which would necessitate heavier hulls and decreased carrying power.

Only a few cases can be given, from the many that might be quoted, where vessels have grounded in a tideway and been left unsupported for considerable parts of their lengths, or have stopped in launching and been suspended in exceptional positions. The well-known case of the *Northumberland*, which stopped on the launching ways at Millwall in 1866, and remained for a month with one-eighth of her length unsupported, may be mentioned, because it has been thoroughly investigated; even this exceptional position did not develop such severe bending strains as would result from suspension on the wave crest. Had the ship been supported only at the middle, the case would have been very different; as it was, the ship maintained her form unchanged. A similar and more recent case is that of H.M.S. *Neptune* which stopped on the launching ways; her bottom crushed up, owing to the concentration of the support near the middle of the length, but the sheer was unbroken, and no serious damage done to the structure. Very different from the condition of these iron ships was that of the wood line-of-battle ship *Cæsar*, which stopped in launching at Pembroke in 1853, and remained a fortnight with 64 feet of the stern unsupported by the ways; her stern dropping no less than 2 feet in 90 feet. Lastly, as a converse case, we may refer to the *Prince of Wales*, an iron steamer, which was left for some time, owing to an accident, supported at the ends only, her bow on the edge of a wharf, and her stern in the water; she also was uninjured. In none of these instances were the extreme conditions of suspension at the ends or middle realised, nor are they likely to be so.

In concluding this part of the subject, it is desirable to glance once more at the conditions of strain in ships subjected to longitudinal bending moments; for the character of such strains is not affected by changes in the magnitude of the bending moment; the intensity of the strains is alone affected. When a ship hogs, the ends dropping relatively to the middle, the upper parts of her structure tend to become stretched, i.e. they are subjected to tensile strains, while the lower parts are subjected to compressive strains; and somewhere near the middle of the depth there is a part of the structure subjected neither to tensile nor compressive strains. Conversely, when a ship astride a wave hollow is subjected to sagging moments throughout her length, the lower parts are subjected to tensile strains, and the upper parts to compressive strains, the parts near the mid-depth again being free from strain. These two cases are practically of the greatest importance, because the strains of all classes of ships,

when floating amongst waves, may be grouped under them, no matter what the still-water distribution of weight and buoyancy may be, and the wave-water strains are considerably greater than the still-water strains. It is worthy of note, however, that, when a ship is subjected for a portion of her length to hogging strains, and for the remaining portion to sagging strains—a condition exemplified by the *Devastation* in Fig. 86—then the upper decks and top sides of those parts subjected to hogging moments tend to stretch, whereas they are subject to compressive strains at the parts subjected to sagging moments. At those athwartship sections of such a ship corresponding to the points *cc* in Fig. 86, where the curve of moments MMM crosses the base-line AB, no bending moments exist, and consequently there is no development of either tensile or compressive strains. These general considerations must suffice for the present; in the following chapter we shall investigate more fully the character and magnitude of the strains resulting from longitudinal bending moments, as well as the manner in which these strains are resisted by the structure of a ship.

Attention will next be turned to the causes and character of the chief strains tending to produce changes in the *transverse forms* of ships.

The most severe transverse bending likely to be experienced by a ship at rest is that resulting from grounding or being docked. Fig. 89 will illustrate this case. Suppose that, for an instant, the

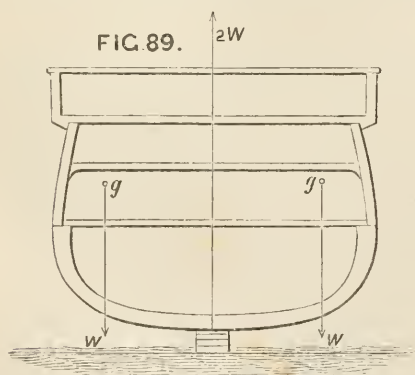

vessel is wholly supported on her keel; then the blocks or the ground must furnish an upward pressure to balance the total weight of ship and lading, and this is indicated in the diagram by $2W$ acting vertically. Considering each side of the ship to bear an equal load, the total of hull and lading for one side of the ship is W , a downward

pressure acting through g , the centre of gravity of the hull and lading of that side. The transverse distance of g from the longitudinal middle plane of the ship depends, of course, on the distribution, in a transverse sense, of the weights carried. If these

weights are placed centrally, g will lie much nearer to the middle plane than if the weights are "winged"—carried far away from the middle. For instance, in an armoured ship several hundred tons of armour may be carried on the broadside, and a great weight of coal in the wings; in which case g will lie far out. On the other hand, a merchant ship may have her cargo—say of rails or heavy materials—stowed almost at the centre, along over the keel; in which case g will lie near the middle plane. When the distribution of the weights is known, the position of g can be determined; the transverse bending moment will (under the conditions assumed) equal the product of W into the distance of g from the middle plane. This moment tends to make the bilges drop relatively to the middle, and to break off the ribs of the ship at the middle line, but before actual deformation takes place the deck-beams and plating on the decks must be brought into tension, and will effectually assist the lower parts of the structure in resisting change of form.

This is an extreme case, not often realised perhaps, but sometimes occurring. A ship left aground by the retreating tide is either likely to remain partially water-borne or else, when left high and dry, she will "loll" over and rest on one of her bilges as well as on the keel. A ship, when docked, is generally supported by shores as the water leaves her; so that the upward pressure from the blocks is not equal to the total weight, nor is the transverse bending moment nearly so severe when the shores take part of the weight. It is, however, certain that ships in dock, especially wood-built ironclad ships, require to be very carefully supported by shores, in order to prevent changes of transverse form; and many cases are on record where such changes have actually taken place. The converted ironclads of the Royal Navy have, for example, been found to "break" transversely when in dock, even when well shored; and it has been suggested to use bilge-blocks in order to lessen the strains. Such blocks have been used for this purpose, both in this country and abroad, in vessels of unusual form. The American monitors are said to be thus supported when in dock; and the flat-bottomed floating batteries built for the Royal Navy during the Crimean War were docked on bilge as well as central blocks. The reduction of transverse bending strains by these special supports is easily explained; for instead of an upward pressure W at the middle line and the downward force W forming a couple, the resultant of the pressure on the keel-blocks and bilge-blocks will necessarily lie some distance out from the middle and closer to the line of action of the downward force W .

Ships afloat and at rest in still water are not usually strained so severely as vessels supported on the keel only; for a reason

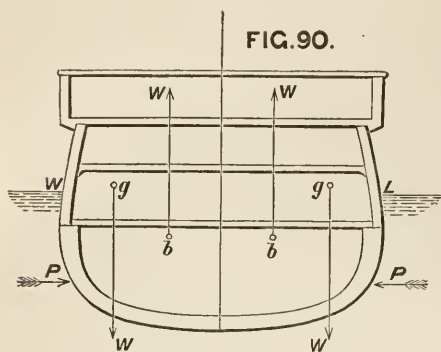

very similar to that just given. Fig. 90 illustrates this case. Taking one half the ship separately, its weight W acts through g , as before explained; but the support W is now furnished by the buoyancy of that half of the ship acting upwards through b , the centre of buoyancy for that half. Probably

the case illustrated in the diagram is the most common, g lying further from the middle than b ; but in some ships with great weights of cargo stowed centrally over the keel, it is conceivable that the relative positions of g and b may be reversed, g lying nearer to the middle of the ship.

The horizontal fluid pressures also contribute towards producing changes of transverse form. The pressures P, P in Fig. 90 are equal and opposite when the ship is at rest, but, as she is not a rigid body, or a solid, she tends to become compressed by the equal and opposite pressures. This is a parallel case to that given before for longitudinal bending strains; only here the pressures are much greater than for longitudinal strains. For example, in the *Minotaur* the longitudinal pressures amount to about 400 tons, whereas the transverse pressures would amount to about 3500 tons. The transverse pressures PP may be considered to act along lines at a depth below water equal to about two-thirds of the mean draught when the ship is upright. When she is inclined, similar, but possibly more severe compressive strains will be caused by the fluid pressures, the tendency being to force the bilges inwards, and thus to distort the transverse form.

The most marked indications of these compressive strains are usually to be found near the extremities, where the sides are flat and nearly upright. Many instances have been noted where "panting," as it is termed, has taken place in those parts of badly constructed ships, the sides moving in and out under varying conditions. Such changes of form are, however, very easily prevented by simple structural arrangements, as will be shown further on.

Rolling oscillations lead to a great increase in the strains

tending to alter the transverse forms of ships. This will be obvious, from the remarks previously made respecting the accelerating forces developed during rolling, and the changes in magnitude and direction which these forces undergo during the motion.* When the

period and range of the oscillation are known, and the conditions of statical stability have been ascertained for the ship, it is possible to approximate to the racking strains produced by the accelerating forces; but their general character can be understood apart from calculation.

Referring to Fig. 91, the cross-section of a ship will be seen in an inclined position, representing the extreme angle of heel attained when rolling. When the motion ceases, the accelerating forces reach their maximum value, and their straining effect is greatest. This straining action tends to distort the form of the transverse section as indicated in a greatly exaggerated form, by dotted lines, changing from ABCD (*drawn* lines) to *abcd* (*dotted* lines). At the angle B there is a tendency to make the inclination of the deck to the side an *acute* angle; on the opposite side, at A, there is a tendency to make the corresponding angle *obtuse*. At the bilges corresponding changes are indicated; the general character of the change may be described as resulting from the tendency of the parts to keep moving on in the direction in which they were moving before the maximum heel was reached. Experience fully confirms the theoretical deduction, that rolling motion develops straining forces tending to change the angles made by the decks with the sides. In wood ships, working at the beam-arms is very common during heavy rolling at sea. Beam-knee fastenings work loose, and other indications of strain or working occur. At the bilges also in wood-built steamships, working sometimes takes place during rolling, and unless precautions are taken, pipes, &c., will be broken at the joints, or disturbed by the change of form; in fact, the attention that has been bestowed by practical shipbuilders

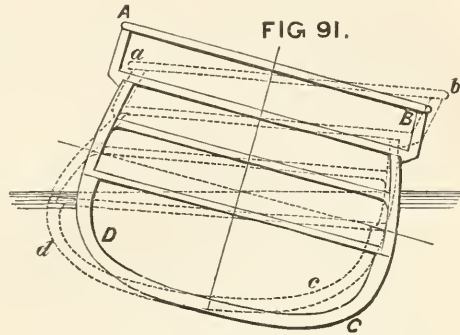

* See page 232.

upon beam-knees and other fastenings intended to secure rigidity of transverse form can scarcely be paralleled from any other part of the structure.

The racking strains produced by rolling have their effect greatly enhanced by the changes in direction and intensity occurring during each oscillation; and hence it is that the range of oscillation as well as the period are such important elements in a comparison of the transverse racking strains experienced by two ships. Allusion has already been made to this in discussing the behaviour of ships at sea, but it is desirable to further illustrate the matter, and for this purpose it is necessary to make use of an approximate rule for the maximum value of these racking strains. The late Professor Rankine, whose labours in connection with naval architecture were worthy of his high reputation in other branches of research, proposed such an approximate rule, which is as follows:—

$$\left. \begin{array}{l} \text{Moment of racking} \\ \text{forces} \end{array} \right\} = \frac{D^2}{D^2 + B^2} \times \left\{ \begin{array}{l} \text{Righting moment for} \\ \text{maximum heel at-} \\ \text{tained,} \end{array} \right.$$

where D = total depth of ship from upper deck to keel,
 B = breadth of ship.

Applying this rule to two typical ships, one having a short period like the *Prince Consort* class, and another having a long period like the *Hercules* class, a remarkable contrast becomes apparent. Actual observations show that the *Hercules* only rolled 15 degrees on each side of the upright when a converted ironclad was rolling 30 degrees each way. Suppose these figures to be used. For these two vessels, the respective values of B and D are approximately equal, the ratio $\frac{D^2}{B^2 + D^2}$ being about 1 to 3 for each ship. Assuming this ratio to be used, it is found that the moment of racking forces at the extreme of the heavy roll of the *Prince Consort* would be about 7000 foot-tons, and the corresponding moment at the extreme of the moderate heel of the *Hercules* would be about one-third as great. The *Prince Consort* has a period of about 5 seconds; consequently, twelve times every minute a racking moment of the amount stated will be acting upon her structure, and at intervals of 5 seconds the distortion will tend to take place in opposite directions. In the *Hercules*, with a period of about 8 seconds, a racking moment less than one-third the amount of that in the *Prince Consort* will be acting only seven times every minute, and the tendency to distort will

change its direction at intervals of about 8 seconds. The less frequent change of strain and the diminished moment tell greatly in favour of the slower-moving and steadier ship. What has here been shown to hold good for particular ships holds good also for ships in general. Lengthening the period of still-water oscillations not merely makes ships steadier in a seaway, but greatly reduces the effect of strains tending to produce changes in the transverse forms, or damage to the masts and rigging. Deep-rolling ships are also the quickest in their motions, and require the greatest strength in hull and equipment.

Hitherto investigations of the forces tending to produce changes of transverse form in ships have been, for the most part, of a qualitative character. Estimates of the magnitude of these forces in different classes of ships are almost entirely wanting; and no *data* are available for transverse strains, similar to the figures for longitudinal bending moments given in the table on page 299. Probably greater attention might, with advantage, be given to the consideration of transverse strains, and it is to be hoped that the subject will receive the consideration it deserves now that the character and amount of longitudinal bending moments have been so fully investigated.

Little need be said respecting the strains produced by the propelling apparatus upon the structure of a ship considered as a whole, although this third class of strains is by no means unimportant. When a ship is propelled by sails, the effective wind pressure may be resolved into two parts: one acting longitudinally and constituting a "thrust" which propels the vessel on her course; the other acting transversely, producing leeway and an angle of steady heel. When the motion of the vessel is uniform, the longitudinal thrust exactly balances the fluid resistance to the motion ahead; the thrust and resistance form a mechanical couple; and the "centre of effort" of the sails, where the resultant thrust may be supposed to be delivered, will be at a great height above the line of action of the fluid resistance. This couple by its action must produce two effects on the ship: first, a change of trim—deeper immersion by the bow—corresponding to its moment; * second, a longitudinal racking action upon the structure of the ship. The character of this racking action may be simply illustrated by taking a rectangular frame

* For the principles upon which the calculation of this trim would be based, see Chapter III.; for a discussion of propulsion by sails see Chapter XII.

formed of four pieces of wood, joined to one another at the angles, and supposing either pair of its parallel sides to be acted upon by forces equal in magnitude, but opposite in direction. Obviously, the rectangle would become distorted into a rhomboid, unless the connections were very strong; but by means of a diagonal tie, like that on an ordinary field-gate, this racking or change of form may be very easily prevented. The corresponding tendency in ships is also unimportant, because of the large reserve of structural strength to resist such strains.

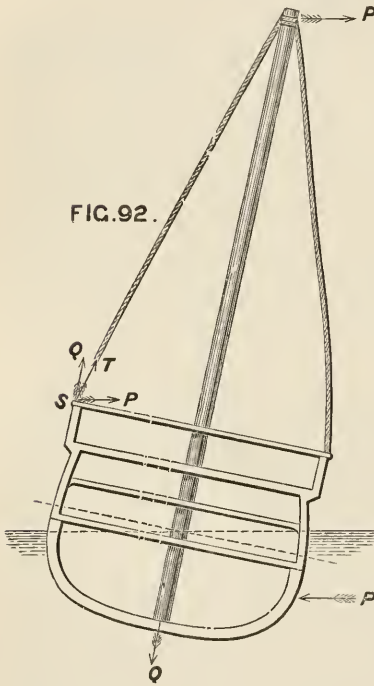

Similar considerations hold good for the strains produced by the transverse component of the wind pressure. When the drift to leeward has become uniform the fluid resistance will supply a lateral resistance (P in Fig. 92) equal and opposite to the transverse component of the wind-pressure. Under the action of this couple the vessel will heel steadily to an angle for which the righting moment equals the moment of the inclining couple (see page 75). At the same time a transverse racking strain will be brought into action on the structure of the ship. The shrouds on the windward side will be taut, and have a tension (T Fig. 92) brought upon them, which tension will be governed by the force of the wind-pressure (P), the angle of heel of the ship, the overhanging weight of the masts, rigging and sails, the angle between the shrouds and the mast, and the stiffness of the mast to resist deflection under pressure. This tension also gives rise to a thrust delivered by the mast upon its step (Q Fig. 92); and the united action of these forces tends to produce an alteration in the transverse form. Professor Rankine estimated the probable maximum bending moment of these forces at one-half the moment of statical stability corresponding to the angle of steady heel; and if this estimate be accepted, as it is reasonable to do, it will be seen that the transverse racking moment for a steady pressure of wind is so

small in amount as to be practically unimportant in its effect upon the ship considered as a whole. If the wind acts on the sails in gusts or squalls the straining effect will be much increased; and when to this irregular action of the wind is added the influence of the accelerating forces incidental to the rolling or lurching of ships among waves, it is evident that great and variable strains may be brought upon the structure of a sailing ship, of which the amounts are not easily ascertainable. Experience proves, however, that when damage occurs under these circumstances it is usually of a *local* character: as for example, a failure in the connections of the shrouds to the ship at the channels and chain-plates, or a disturbance of the deck near the wedging to the masts. And with these local strains we are not at present concerned.

With steam as the propelling agent, the case is simpler than with sails. The thrust of the propeller will usually be delivered in the direction of the course of the ship, and will therefore have no transverse component; moreover, the line of action of that thrust will lie very much closer than it does with sail power to the line of action of the fluid resistance. When the screw is employed, the line of thrust for the propeller approximates to coincidence with the line of action of the resistance; and when paddles, or jet propellers, are used, the thrust is delivered at a comparatively small height above the line of action of the resultant resistance. It is unnecessary, therefore, to add any further remarks on this part of the subject, the ship considered as a whole being but little strained by the propelling apparatus.

The last class of strains to be considered are those grouped under the head of *local strains* in our classification. Of these, there is such a great number and variety that an exhaustive treatment of the subject will scarcely be found in works on ship-building; and all that can be done in the present sketch is to select a few of the principal types, indicating the causes and character of the strains. As a matter of convenience, we shall adjoin, in each case, a brief account of the arrangements by which the strain is prevented from producing local damage or failure.

At the outset it may be well to note that the same circumstances which have already been mentioned as producing strains upon a ship *considered as a whole* may and do produce severe local strains. For example, a heavy load concentrated in a short length, not merely contributes to the longitudinal bending

moment previously described, but also tends to push outwards that part of the bottom upon which it rests. Similarly, the thrust of a screw propeller not only tends to rack the ship as a whole, but produces considerable local strain on that part of the ship to which the "thrust-bearer" is attached. Again, the downward thrust of a mast, besides tending to alter the transverse form of the ship as a whole, produces a considerable local strain on the step, and on the frame of the ship which carries the step. And these are only a few illustrations of a general principle. When the ship is treated as a whole, it is virtually assumed that these local strains have been provided against; so that the various parts of the structure can act together and lend mutual assistance. As a matter of fact, however, it is not at all uncommon to find local failure supervening long before the limit of the strength of a ship considered as a whole has been realised. The case of the *Neptune*, previously quoted, well illustrates this; when she stopped in launching, her general structural strength was ample even against the severe bending moments experienced; but while her longitudinal form remained almost unchanged, the very exceptional local strains on a small portion of the bottom forced it inwards, disturbing the decks, &c., above it. Many similar examples might be added, but enough has been said to show how important it is to provide carefully against local strains in arranging the structure of a ship.

One of the chief causes of local straining has already been mentioned; viz. a great concentration of loads at certain parts of a ship; and the converse case is also important—that where there is a great excess of buoyancy on a short length. Examples have been given of such concentration of loads; one of the most notable is that for the *Devastation*, in wake of the turrets (see Fig. 85), where there is an excess of weight over buoyancy 550 tons on a length of about 30 feet. Still more concentrated is the load of armour on a battery bulkhead, weighing perhaps 60 or 80 tons, and lying athwartships. Immediately in wake of such concentrated loads the bottom tends to move outwards from its true shape; the local strain which is developed tending to produce simultaneously both longitudinal and transverse change of form. Many similar causes of straining will occur to the reader; it is only necessary to mention the cases of a vessel with a heavy cargo, like railway iron, stowed compactly, or of a vessel with heavy machinery carried on a short length of the ship, or of the parts adjacent to the mast step of a sailing ship.

Surplus buoyancy on a ship afloat is not usually found so

much concentrated as surplus weight; but in some instances the excess of buoyancy produces a considerable local strain tending to force the bottom upwards for a portion of the length. Lateral pressures as well as vertical pressures require to be provided against, especially near the extremities of ships.

To prevent local deformations of the bottom in wake of excesses either of weight or buoyancy, the shipbuilder employs a very simple and well-known device. The concentrated load or support is virtually distributed over a considerable length by means of strong longitudinal keelsons, bearers, &c. In not a few cases these longitudinal pieces are additions to the main framing or structure of the ship; in other cases they form part of the main structure, being effective against the principal strains as well as against local strains. The latter plan is preferable, where it can be adopted, favouring, as it does, lightness and simplicity of construction. These longitudinal bearers and strengthenings can only distribute loads or pressures when they are individually possessed of considerable strength; and to be efficient they must be associated with structural arrangements which provide ample transverse strength (such as complete or partial bulkheads, strong frames, &c.), and form points of support to the longitudinals. Frequently the longitudinals must be continued through a length sufficient to connect and secure the mutual action of parts where there is an excess of weight with others where there is an excess of buoyancy. But in very many ships, and especially in iron ships, there are cross-sections, like those at bulkheads, where alteration of the form is scarcely possible. In such cases the bearers distributing a concentrated load or pressure frequently extend from one of the strong cross-sections to the next: just as the girders of a bridge extend from pier to pier, and, if they are made sufficiently strong, can transmit a concentrated load placed midway between the piers to those supports without any sensible change of form.

The *Great Eastern* furnishes a good example of the last-mentioned arrangement. In the lower half of her structure there is very little transverse framing. Numerous and strong transverse bulkheads supply the strength requisite to maintain the transverse form unchanged. Strong girders, or frames, extend longitudinally from bulkhead to bulkhead, and transmit the strength of the bulkheads to the parts lying between them. Arrangements of a similar, but not identical, character are also made in the ironclad ships of the Royal Navy, and in merchant ships built on the cellular system (see Chapter IX.). The engine

and boiler bearers in many iron steamers are also arranged on this principle.

Vessels with few transverse bulkheads, or with none, have strong keelsons, binding strakes, stringers, and other longitudinal strengthenings on the flat of the bottom below the bilges, these pieces distributing loads and adding to the structural strength. This is the common arrangement in wooden ships of all classes, as well as in iron sailing ships. Recently, however, in the wood-built ships of the Royal Navy and the French navy iron bulkheads have been constructed, and, in some cases, iron bearers and keelsons have been fitted. The wood-built American river steamers furnish curious illustrations of the connection of parts of a ship having surplus buoyancy with others having surplus weight. Besides strong longitudinal keelsons, the builders have recourse to the "mast-and-guy" system. Poles or masts are erected at parts of the structure having surplus buoyancy; these masts are stepped upon strong timber keelsons. Chain or rod-iron guys are then secured to the heads of the masts and connected at their lower ends to parts of the vessel where considerable weights are concentrated, thus hanging these parts on, as it were, to the buoyant parts. In this fashion, the long fine bows and sterns are prevented from dropping; and, in wake of the machinery, tendencies to alter transverse form are similarly resisted. Such arrangements are, of course, only applicable to vessels employed in smooth water, not subjected to the changes of strain to which sea-going ships are liable. The guy-rods can transmit tension, but not thrust; and the plan is said to have answered admirably in these long fine vessels, having great engine-power and high speed.

Grounding is another cause of more or less severe local strains, the intensity depending upon the amount and distribution of the supports. Very concentrated supports, as has already been shown, may crush up the bottom; distributed support such as a ship obtains when docked or fairly beached produces strains which can be easily met. Every provision described above for giving stiffness to the bottom of a ship is also efficient in helping her when aground. In fact, to these provisions shipbuilders mainly trust, making few special arrangements against local strains due to grounding, and these almost wholly at the extremities. Nor is this surprising, for it is impossible to foresee all the conditions of strain, or to provide against them, and such accidents to any individual ship are comparatively rare.

Penetration of the skin of a ship ashore often takes place with-

out any serious crushing up of the bottom; and this danger is of peculiar importance to iron and steel ships, having skin plating never exceeding an inch in thickness, and in the great majority of cases less than half that thickness. Sharp hard substances, such as rocks, will penetrate the plating more readily than they will penetrate the much thicker bottom of a wood ship. This superiority of wood ships in sustaining rough usage ashore without penetration of the bottom is well known; and some persons have attached such importance thereto as to advocate the construction of ships with wooden floors and bottom planking, but otherwise of iron. The plan has, however, obvious disadvantages, and has not found much favour with ship-builders, who prefer to accept this occasional disadvantage of iron, rather than to sacrifice its superiority in other respects to wood.

It is sometimes assumed that iron bottoms are more inferior to wood in their resistance to penetration than is really the case. To the experiments of the late Sir W. Fairbairn, we owe more exact knowledge on the subject than was previously accessible; in these experiments, a few comparative tests were made of the resistances of wood planks and iron plates to the punching action of a very concentrated support.* Under the experimental conditions an oak plank 3 inches thick was found equal in resistance to an iron plate $\frac{1}{4}$ inch thick; and a 6-inch plank to a plate 1 inch thick. Planking appeared to offer a resistance proportional to the *square* of the thickness; whereas iron plating offered a resistance proportional to the thickness only. The largest iron ships have, therefore, bottom plating about equivalent to a 5-inch or 6-inch oak plank. This would be quite as thick as, or thicker than, the average bottom planking of large wood ships; but within this planking the wood ship probably would have solid timbers and fillings, forming a compact mass, very difficult of penetration, the iron ship having no similar backing to the thin plating. It is therefore easy to see why wooden ships are, as a rule, capable of standing more of the wear and tear incidental to grounding than ordinary iron ships with a single bottom. To attempt to increase the thickness of the bottom plating in order to meet this comparative disadvantage would be wasteful and unwise; the preferable course is to fit an inner skin within the frames, forming a double bottom. Then, if the outer plating is broken through, and the inner still remains intact, no water

* See the account of the experiments given in Sir W. Fairbairn's work on *Iron Shipbuilding*.

enters the hold, and no serious damage ensues, as explained at length in the first chapter.

Such a cellular construction of the double bottom has a further advantage well deserving consideration. Thin iron or steel plating, stretching over the spaces between transverse frames, not unfrequently shows signs of bending or "buckling" between these supports when subjected to the upward or sideways pressure of the water; and this effect may be aggravated by the strains due to hogging. By means of longitudinal frames or keelsons running along upon the plating, and attached to it, buckling may be prevented; but when, in addition, an inner bottom is worked buckling becomes almost impossible. The experiments, made before the construction of the tubular railway bridge across the Menai Straits was begun, first demonstrated the great advantages obtained by the cellular system applied to wrought-iron structures, especially in those parts subjected to compressive strains. Since then the knowledge of this fact has been made generally useful, both in ship and in bridge construction.

When a ship sags, the upper deck and top sides are subject to compressive strains; to meet these, as well as hogging strains, more efficiently, a cellular construction of the deck has in some few cases been adopted. The *Great Eastern* is a case in point, to which reference will be made hereafter. Longitudinal supports are not commonly fitted to decks; the wood planks usually assisting to prevent buckling in the iron or steel plating, if any is fitted.

The local strains on the decks of ships constitute another important group. Very heavy weights are placed upon certain parts of the decks, resting only upon a certain number of the deck-beams; and no little care is needed in connecting the beams with the sides of the ship, arranging the pillars beneath them, or taking other means to distribute the load. If the loads to be carried were known, and the kind of pillaring determined, it would be a comparatively easy matter to fix the dimensions of the beams required to support the loads. In practice, however, these conditions are not commonly fulfilled, and the breadth of the ship amidships, or some other dimension, is had recourse to in proportioning the sizes of the beams. Special cases occur especially in war-ships, where the loads to be carried are excessively great, and their positions can be fixed; as, for example, the turrets of a vessel like the *Devastation*, or the guns in the battery of a broadside ship. Beams of exceptional strength, or beams

spaced more closely than at other places, are often employed in such cases; but even then it is not sufficient to regard the beams as girders supporting certain loads, with the assistance of the pillars. Both beams and pillars, besides meeting these local strains, have to assist in the maintenance of the transverse form of the ship, as will be shown in the next chapter. Sometimes it happens, especially in wake of the machinery or boilers, that it is difficult to fit pillars under some of the beams; but these beams are easily supported by longitudinal girders extending a sufficient distance fore and aft to have their ends upheld by very strong pillars.

Another class of local strains, of special importance in a warship, are those brought upon the bows by collision with another vessel. The importance of ram attacks is now so generally recognised that the great majority of the ironclad ships of all navies have been constructed with bows specially designed for delivering an effective blow upon an enemy without receiving serious damage themselves. Spur-bows, protruding forward under water in such a fashion as to be able to strike the comparatively weak bottom below the armour of the ironclad attacked, are those which find most favour. Whatever may be the form of bow adopted, it must be made exceptionally strong if it is to successfully withstand the shocks and strains produced by ramming. These strains may be arranged in three divisions: (1) direct strains, tending to drive the stem and bow bodily backwards into the ship; (2) twisting strains, tending to wrench the bow off when the blow is struck obliquely, or the vessel attacked has motion across the bow of the ram-ship; (3) strains tending to perforate the skin of the ram-bow, resulting from the jagged parts of the hull of the vessel which has been struck pressing upon the ram, while the two vessels are locked together, and while the wrenching just mentioned takes place. Similar strains act upon the bow of any ship which comes into collision with another; and unfortunately there are too numerous instances of the truth of this statement in the records of accidental collisions between vessels of the mercantile marine, or other ships not built for ramming. In fact, it is to these ordinary vessels, and not to ships specially designed for ramming, that one must look for the fullest evidences of the character of the strains incidental to collision. The bows of many ships have actually been crushed in; or the skin has been penetrated; or wrenching strains—as in the ill-fated *Amazon*, of the Royal Navy—have been so serious in proportion to the strength of the bow as to

twist the latter and cause the ship to founder. On the other hand, we have ample evidence that the special arrangements of ram-bows provide satisfactorily against strains which are fatal to weaker bows.

At Lissa, the Austrian ram *Ferdinand Max*, a wood ship with a strengthened ram-bow, struck and sank the *Re d'Italia*, besides making other less successful attacks on other Italian ships; yet her bow sustained no serious damage, although it suffered more than an iron-built ram would have done under similar circumstances. The improvised Confederate ram *Merrimac* sank the Federal wooden frigate *Cumberland* at Hampton Roads, but wrenched her own spur badly in consequence of its faulty construction, and is said to have been consequently far less efficient in her subsequent fight with the *Monitor*. The disastrous collision between the *Vanguard* and the *Iron Duke* furnished one of the severest tests yet put upon the strength of the ram-bow in one of the modern types of iron-hulled ironclads. To understand the severity of the test, it is necessary to note a few facts given in evidence before the court-martial. At the time of the collision the *Iron Duke* is said to have been going $7\frac{1}{2}$ knots, her course being six points off that of the *Vanguard*; the direct force of the blow delivered was at least 12,000 foot-tons. Fig. 26, page 30, illustrates the damage done to the *Vanguard*, the armour being driven in bodily and the outer bottom pierced by a huge hole some 20 or 30 square feet in area. Such a blow, of course, reacted on the bow of the *Iron Duke*, tending to drive it back into the ship; and meanwhile the *Vanguard* had a speed athwart the bow of the *Iron Duke* of no less than 6 knots, the motion producing a tendency to twist and wrench the bow, as well as to perforate the skin. The simple and comparatively light arrangements of the ram-bow answered admirably when thus severely tested, subsequent examination proving it to be so little damaged that the *Iron Duke* could, in action, have ventured safely on a repetition of the blow, and yet have remained efficient. Much greater damage was done to the ram-bow of the German ironclad *König Wilhelm* when she came into collision with the *Grosser Kurfürst*. A portion of the heavy iron stem of the former was nearly wrenched out of place, and the armour and bow-plating, &c., abutting on the stem were considerably disturbed. Although in some respects the structure of the bow of the German ship was inferior to that of the *Iron Duke*, the differences in the injuries received are probably chiefly due to the fact that at the time of collision the *Grosser*

Kurfürst was crossing the bows of the *König Wilhelm* at a high rate of speed.

Figs. 93-95 have been drawn to illustrate the principal features in the framing of a ram-bow in a ship having a water-

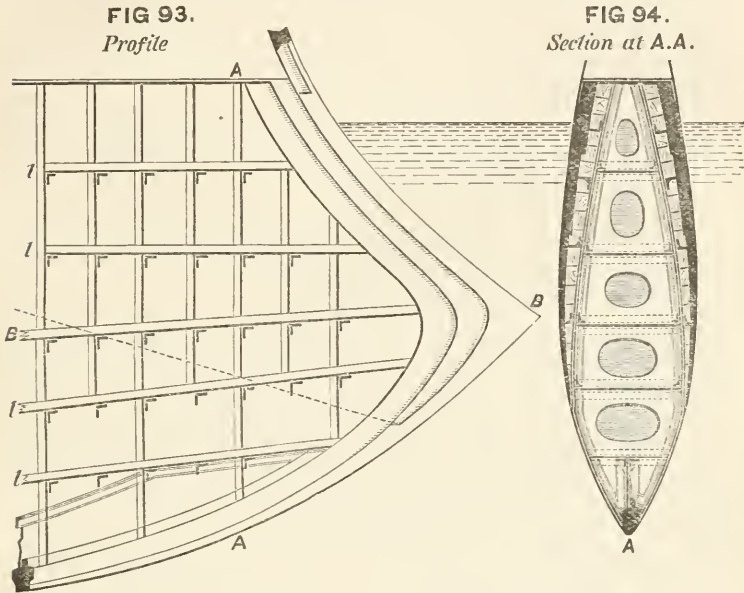

line belt of armour extending to the bow; and only a few explanatory remarks will be required. The stem is a solid iron forging, weighing several tons. Against direct strains tending

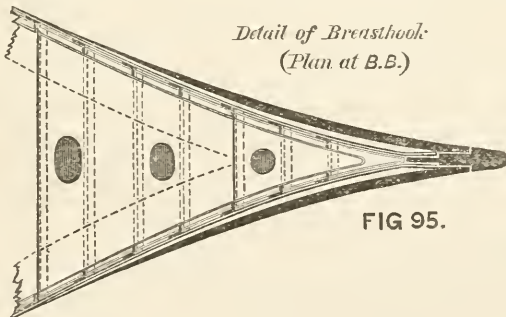

to force it backward, it is supported by the longitudinal frames or breasthooks (*l, l*, in Fig. 93), as well as by the armour-plating, backing, and skin-plating, all of which abut against the stem. The breasthooks are very valuable supports, being very

strong yet light; their construction is shown in Fig. 95; and the foremost ends of the decks are converted into breasthooks in a somewhat similar manner. Wrenching or twisting strains are well met by these breasthooks, stiffened as they are by numerous vertical frames, the details of which appear in Fig. 94, while their positions are indicated in Fig. 93. Perforation of the skin is rendered difficult either by carrying the armour low down over the bow as indicated by the dotted line in Fig. 93 or by doubling the skin-plating forward below the armour. The former plan is preferable, being more efficient against perforation, and also giving protection against raking fire when engaged bow-on to an enemy; it has been very generally adopted of late in the Royal Navy, and the French also favour this plan. Although the transverse framing of the ram-bow is thus quite subordinated to the longitudinals (*l, l*), it plays an important part in binding the two sides together, stiffening the breasthooks, and enabling a minute system of watertight subdivision to be carried out. Even if the outer skin should be broken through in ramming, water would find access to a very limited space, and consequently there would be little or no danger, and no inconvenient change of trim. Such are the main features of the ordinary ram-bow in a belted ship.

Recent ships of the central-citadel type are somewhat differently constructed for ramming. The armoured deck, situated several feet under water, is the strongest part of the structure which contributes the greatest support to the spur-bow. These decks are usually curved downwards at the fore end, for the purpose of gaining such a depth below water as will enable the spur to pierce an enemy below the armour. The spur is attached to the fore end of the deck; by which it is supported most efficiently against direct and wrenching strains. Subsidiary supports, breasthooks, &c., are also employed to a small extent; and in some cases arrangements have been made by which, if the spur should become locked in the side of the vessel attacked, it might actually be wrenched off without any serious damage to the bow. Perforation of the skin below the armour deck is provided against by doubling the plating.

Ram-bows in wood ships may be made fairly efficient, but not so simply or satisfactorily as those of iron or steel ships, the difference being one inherent in the materials. To make the spur more efficient, it is usually armed with a sheath of metal or iron. Massive longitudinal and diagonal timbers are bolted inside the frames, and associated with iron crutches or breasthooks, to prevent the stem from being driven in or twisted when a ram attack is

made. But even when all possible care is taken in fitting and fastening these strengthenings, the combination can scarcely be considered satisfactory. Weakness, working, and decay must affect it, as they do all other parts of a wooden structure. Repairs to such a bow must also prove difficult and expensive, as compared with the corresponding work in an iron-built ram, where all the parts are easy of access, and easily replaced. These are, however, matters of detail requiring no further consideration here, although they have great practical importance.

The superior strength of the bows of iron ships has been illustrated frequently in the mercantile marine, as well as in war-ships. Commonly, when collisions take place between two iron ships, the vessel struck is seriously damaged, perhaps founders, while the striking vessel escapes with little damage to her bows. More than thirty years ago, when the *Persia*, one of the earliest iron-built Transatlantic steamers, was on her first voyage, she closely followed the *Pacific*, a wood steamer, and both are reported to have fallen in with large ice-floes. The *Pacific* was lost with all on board; the *Persia* ran against a small iceberg at full speed and shattered it, but sustained no serious damage.

The last class of local strains to be mentioned are those incidental to propulsion. Some of these have already been alluded to, viz. the strains connected with propulsion by sails, and those resulting from the attachment of the thrust-bearer to the hull of a screw-steamer. To these may be added the strains produced by the moving parts of an engine, through the bearers to which they are secured; vibration or working at the stern of screw-steamers; strains in wake of the shafts of paddle-steamers; and many others. The whole subject is, however, one of detail, requiring to be dealt with during the construction of the vessel by her builder and the maker of the engines. Here again the general principle of *distribution of strain* underlies all the arrangements made. The parts upon which the strains are primarily impressed must be succoured by other parts of the structure, with which they must be connected as rigidly as possible. Change in the relative positions of the various parts cannot occur so long as the connections are efficient, and without such changes working cannot take place. Iron and steel are far better materials than wood for making the connections, and they have been employed very generally for the purpose, even in wood ships, with great success. Vibration may, of course, occur without any absolute working in the structure; for either the ship as a whole may vibrate to and fro, or the observer may be deceived as to motion in the structure

by movements in platforms, or minor fittings forming no part of the structure regarded as a whole, and incapable of resisting strains or transmitting them. This distinction is especially important in vessels of great engine-power and high speed, wherein vibration, either real or apparent, may be considerable, whereas there is absolutely no working.

A single illustration of the usefulness of iron strengthenings in resisting local strains due to propulsion must suffice. Figs. 96–98 contain the details of one of the best examples that could be chosen; representing the arrangements at the stern of one of the wood-hulled ironclads of the Royal Navy. Similar strengthenings have been extensively used in unarmoured wood ships. They

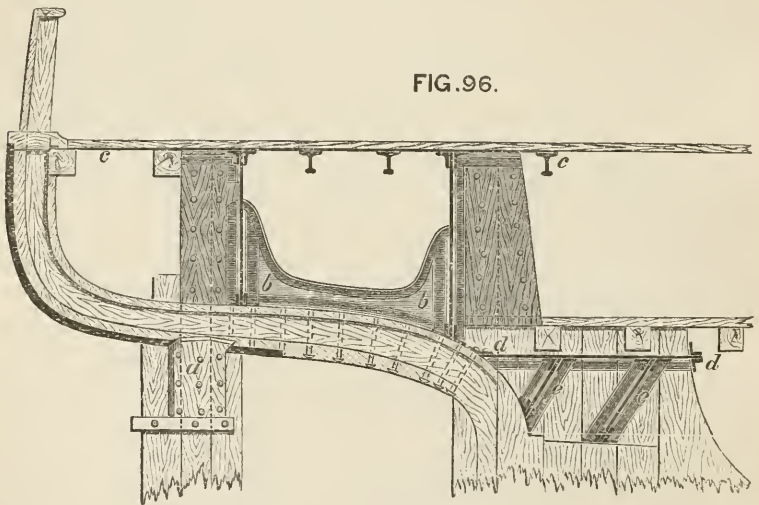

were introduced in consequence of the serious working and weakness not unfrequently experienced at the sterns of the earlier screw steam-ships with good engine-power; and by their use these objectionable results have been altogether prevented. Inside the ship (see Fig. 96) the upper parts of the two stern-posts are cased with iron plates; the heads of the posts are secured to iron plating (*cc*) worked on the upper beams. Between the two posts an iron knee (*bb*) is fitted, and strongly secured to the posts and to the counter of the ship. With a lifting screw, this knee could not be fitted, but the screw-well might then be made an efficient strengthener. Partial bulkheads of iron are built across the stern at the fore side of the rudder-post and the aft side of the body-post. The construction of these is shown in Figs. 97 and 98;

their upper edges are secured to the deck-plating (*cc*), while their outer edges are bolted to the sides of the ship. Change of form is thus rendered practically impossible at those two sections. Change in the angle between the counter and the rudder-post is rendered difficult by the external metal knee *a*, Fig. 96, bolted to the post and the counter. Formerly these counter-knees constituted the main strengthening at the sterns of wood ships, and they were very frequently broken in the "throat" by the working of the post produced by the action of the propeller; now such accidents are scarcely known in the Royal Navy. The body-post is also strongly connected to the hull by the iron plating (*dd*, Fig. 96) under the lower-deck beams, and the brackets (*ee*). By these comparatively light and simple additions of iron strengthenings, what had been previously found an almost

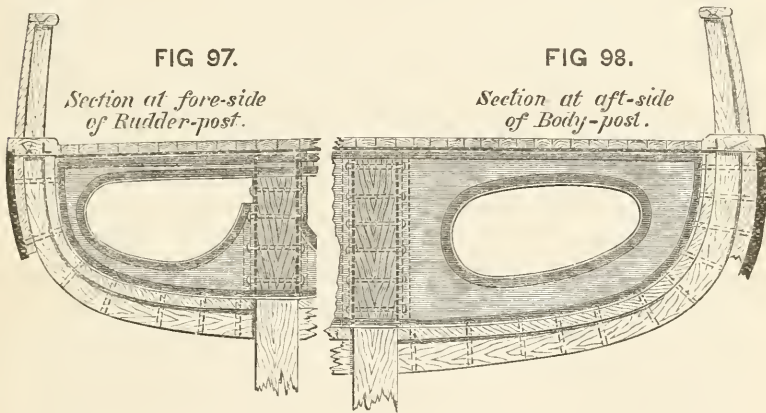

insoluble problem has been satisfactorily dealt with. This is but one example from the many which any reader interested in the subject will discover on investigating the details of construction in various classes of ships.

The local strains incidental to propulsion by sails require to be carefully guarded against. Masts must have considerable strength in themselves to resist both the bending strains tending to break them off near the upper wedging-deck and the compressive strains due to the thrust produced by the tension of the shrouds. Strong shrouds, stays or other supports must be associated with the masts; these should have as good a "spread" as possible (i.e. make as large an angle as possible with the masts); and all such supports must be well secured to the hull proper by chain-plates, channels, &c. Neglect of proper precautions,

in making extensions of practice beyond the limits of precedent, have led to accidents, and to the dismasting of many sailing ships. During the period 1874-77 accidents of this kind were so numerous amongst iron merchant ships of large size and great sail-spread, fitted with iron masts, that the Committee of Lloyd's Register of Shipping gave special attention to the matter. Their professional officers drew up a report which contained a most able and exhaustive discussion of the strains to which masts and rigging are subjected, and of their strength to resist those strains. In this report also appears a summary of the ordinary practice of the mercantile marine in the equipment of sailing ships: and the information there given is of no less value than the more scientific portions of the work. When scientific analysis has been carried to its limits in this matter, recourse must be had to the particulars of the masts and rigging of ships which have borne successfully the strain and stress of service when deciding on the corresponding features in other ships. This method of procedure has long been followed in the Royal Navy, where the *data* as to masting, &c., obtained and tabulated long ago for the now obsolete classes of sailing ships, have furnished rules for practice up to the present time, and have made serious accidents, such as dismasting, almost unknown. Considerable changes have had to be made in consequence of alterations in the structures or types of ships; but where special causes have intervened, special precautions have been taken. For example, in the *Monarch*, where it was desirable to remove all possible obstructions to the fire of the turret guns, the masts were made of exceptional size and strength, in order that they might be capable of standing with fewer shrouds than usual when the ship was cleared for action. In other ships where the spread of the rigging has been less than usual, the shrouds have been made exceptionally strong. Rigid tripod supports to the masts have also been used in a few rigged turret-ships, in order to secure an increased horizontal range of fire for the guns. All these variations in practice have been successfully carried out, by means of a careful and intelligent adaptation of the experience gained in preceding ships.

CHAPTER IX.

THE STRUCTURAL STRENGTH OF SHIPS.

THE structural arrangements now adopted in various classes of ships are the results of long continued development. Their origin is lost in antiquity, and many of the succeeding steps cannot be traced. During long periods, under the same conditions, methods of construction have remained unchanged; but altered circumstances and fresh requirements have produced great and rapid changes. From the canoe hollowed out of a single tree, or the coracle with its light frame and flexible water-tight skin, on to the enormous floating structures of the present time is a very remarkable advance; but the steps have been gradual, and not unfrequently unintentional, the full value of a new feature not being recognised until long after its introduction. The history of this gradual change and improvement, culminating in the wonderful progress of the last half-century—into which have been crowded the development of ocean steam navigation, the introduction of iron and steel sea-going ships, and the use of armoured war-ships—constitutes a most interesting field of study; but in the present work it cannot be touched. Nor can the structural arrangements of existing types of ships receive any detailed illustration, for which the reader must turn to strictly technical treatises on shipbuilding. It will be our endeavour—bearing in mind what has been already said respecting the causes and character of the principal strains to which ships are subjected—to make clear the general principles governing the provision of their structural strength. In doing so, it will be possible to illustrate the distinctive features in the principal classes of ships, to compare the relative efficiencies of various methods of construction, and to contrast the degrees of importance attaching to different parts of the hull of any ship. All that will be assumed is that the reader has a general acquaint-

ance with the names of the different parts; and in most cases even that extent of knowledge will scarcely be requisite in order to follow the discussion.

All ships may be said to consist of two principal parts: (1) the water-tight skin forming the covering of their bottoms, sides, and decks, if they have decks; (2) the framing or stiffening fitted within the skin to enable it to maintain its form. There are many ways of forming the skin in different classes of ships; some of these will be described. Wood, iron, and steel are the three materials at present used for the purpose in sea-going ships; brass skins have been fitted to some small vessels designed for smooth-water services. A skin is an essential part of every ship; and much care and skill are required in its arrangements. Vessels have been built with little or no framing; but these are not ordinary cases, and probably the greatest varieties of practice are to be found in the arrangement of the framing, which constitutes a very important element of the structural strength. In constructing both skin and framing, and considering every detail of the hull, the shipbuilder should seek most fully to combine strength with lightness. To do this, he must possess an intelligent acquaintance with the causes and character of the strains to be resisted, their possible effects upon different parts of the structure, and the principles of structural strength. He is then able to choose from among the materials obtainable those best adapted for his purpose; he can duly proportion the strength of the material to the strains on the various parts, massing it where requisite, or lightly constructing parts subject to little strain; and so far as the requirements of convenience and accommodation, or of fighting efficiency, permit, he can approximate to an ideally perfect structure, in which each part is equally strong as compared with the strain it has to bear. No structure is stronger than its weakest part; consequently a bad distribution of the materials can only be made at the sacrifice of strength, which might be secured if the material were distributed more in proportion to the straining forces.

Another important practical matter is that of the connections and fastenings of the very numerous pieces making up the hull of a ship. Unless great care is taken, the ultimate strength of these pieces will never be developed, and the structure may fail through lack of rigidity, even when it contains an amount of materials which would be ample if they were properly combined. The character of these connections must bear an intimate relation to the qualities of the materials. With wood they are necessarily

different from what they would be with iron or steel. In fact, the builder has to consider this feature in making the choice of his material; having regard not merely to the ultimate resistance of a *single piece* to tensile or compressive strains, but also to the possibility of making a *combination* of two or more pieces efficient against such strains. Having made his choice, he has to effect the best possible connections and combinations, often at no small cost, in order to secure the joint action of the various pieces, and the rigidity of the structure considered as a whole.

In the present chapter it will be convenient to assume that the best possible results have been secured by the builder in each class of ship, and then to investigate their resistances to the *principal* bending strains, tending to alter the longitudinal and transverse form. Local strains have received in the preceding chapter all the attention that can be given them; and in the succeeding chapter we shall illustrate the capabilities of wood, iron, and steel as materials for shipbuilding.

The severest strains to which ships are subjected are those tending to produce longitudinal bending; and therefore the greatest strength is requisite to prevent change of form in that direction. If the ship were subjected to excessive bending moments, developing strains greater than her strength could resist, their ultimate effect would be to break her across at the transverse section where the strains reach their maximum; and this section would usually be situated near the middle of the length. Unfortunately, cases are on record where this ultimate effect has been produced, and vessels, when very severely strained, have actually broken across;* but ordinarily, instead of actual fracture, we have only to consider a tendency to produce fracture at any cross-section of the ship, the structural strength being ample in proportion to the strains. In either case one thing is clear, viz. that resistance to longitudinal bending or cross-breaking at any transverse section of a ship can only be contributed by those pieces in the structure which *cross* the probable line of fracture, i.e. the particular transverse vertical

* One of the most singular cases on record is that of the *Chusan* iron steamer, which broke in two outside Ardrossan, a few years ago, one part of the vessel floating into the harbour, while the other sunk outside. It is only proper to add that this ship was not built for sea-going service, being

designed for the shallow waters of China. Her length was 300 feet, beam 50 feet, and depth in hold only 11 feet. Another case in point is that of the *Mary*, which broke in two in the Bay of Biscay; she was also a shallow-draught vessel of great length, in relation to her depth: see page 299.

section of the ship which is being considered. Pieces lying longitudinally or diagonally in the ship may fulfil this condition, and therefore contribute to the longitudinal strength; but pieces lying transversely, such as a transverse rib or frame or beam adjacent to the line of fracture, do not cross it, and therefore do not contribute to the longitudinal strength. By this simple rule it is, therefore, easy to distinguish those parts of the hull which are efficient against the principal bending moments. Chief among these may be mentioned the skin planking or plating on the outside of the ship; the planking or plating on the decks; and the longitudinal frames, keelsons, shelf-pieces under beams, water-ways, side-stringers, and diagonal iron riders. For any transverse section of the ship, the enumeration of all these parts and the estimate of their respective sectional areas are very

FIG. 99.

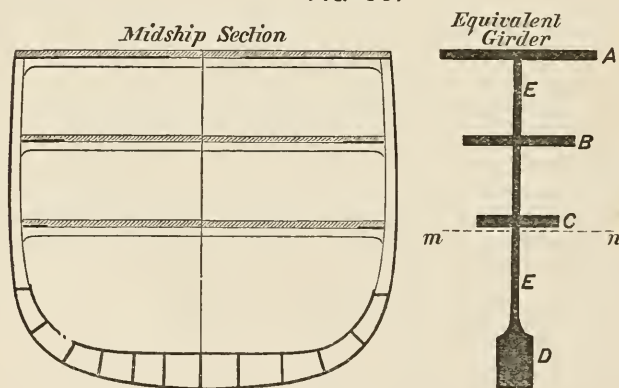

simple processes, upon which the calculation of the strength of the ship at that section is based.

The greatest bending strains being experienced at or near the midship section, let it be assumed for purposes of illustration that the ship is upright, and that it is desired to ascertain the strength of the midship section against cross-breaking strains. In performing this calculation, it is usual to construct an "equivalent girder" section, similar to that shown in Fig. 99. On the left is drawn an outline of the midship section of an iron ship with a double bottom, and with longitudinal frames between the outer and inner skins, these latter being indicated by the strong black lines. On the decks, the planking, plating, and stringers will also be distinguished from the transverse beams upon which they are supported. The *effective areas* of all these

pieces which cross the midship section, and extend to some distance before and abaft it, are represented in the "equivalent girder" on the right. The deck planking, and plating on the upper deck are concentrated in the flange A; those of the middle deck in the flange B, and those of the lower deck in the flange C. The inner and outer bottom plating, longitudinal frames, &c., from the turn of the bilge downwards are concentrated in the lowest flange or bulb D; the vertical or nearly vertical plating on the sides, together with the longitudinal stiffeners worked upon it, form the vertical web EE, connecting the flanges. It will be observed that the depths of the girder and midship section are identical, and all the corresponding pieces in both are situated at the same heights, the vertical distribution of the pieces on the midship section being maintained in the girder.

There are many important matters connected with the work of constructing equivalent girders; but one or two only of the most important can be mentioned. First, it is necessary to distinguish between the *total* sectional areas of the longitudinal pieces on the midship section, and their *effective* areas which are shown on the girder. A very simple illustration will show the character of this distinction. In wood ships it is usual to arrange the "butts" of the outside planking so that at least three planks intervene between consecutive butts lying on the same transverse section. Fig. 100 shows this arrangement; *b* and *l* are two butts placed on the same timber; and the probable line of fracture of the planking between these butts is indicated. Against tensile strains tending to pull the butts open on any section such as *bl*, the butted strakes have little or no strength; therefore, in order to allow for this weakening of the midship section, *one-fourth* of the total sectional area of the outer planking must be deducted. Further, there must be bolts or wooden treenails driven in the unbutted planks, to secure them to the ribs of the ship; and the holes cut for these fastenings at any cross-section may be taken as equivalent to a further loss of about *one-eighth* of the total sectional area. Putting together the allowances for butts and fastenings, it appears therefore that the *effective* sectional area of planking thus arranged is about *five-eighths* of the total sectional area when resistance to *tensile* strains is being considered. But when *compressive* strains have to be resisted, the conditions are different. If the butts are properly fitted and caulked, the butted strakes are nearly, if not quite, as efficient as the unbutted strakes; and if the bolts and treenails properly

fit their holes, no deduction need be made for these holes. Hence, against compressive strains, the effective area practically equals the total sectional area. Similarly, in iron ships, the holes for the rivets securing the outer plating to the ribs cut

FIG 100.

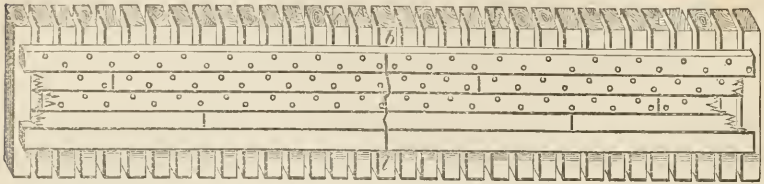

away about one-seventh or one-eighth of the total sectional area, and this deduction must be made from the total area in order to find the area effective against tensile strains; whereas against compressive strains no such deduction is needed. In many other instances similar allowances are required; but the process is an easy one when the details of the construction of a ship are known.

Some shipbuilders prefer to dispense with this determination of effective sectional areas, and use total sectional areas in constructing the equivalent girder; which is therefore the same both for hogging and for sagging strains. This procedure is not so accurate as that described above, but it economises labour and affords a fairly good means of comparison between ships of similar type and structure. It is chiefly employed in calculations for merchant ships where the severest strains experienced are usually hogging strains bringing the decks and upper works into tension; and so long as the departure from accuracy is borne in mind the process is unobjectionable. But in computing the strains corresponding to a given bending moment, the employment of the total instead of the effective sectional areas, leads to results which fall below the truth; so that larger "factors of safety" (see Chapter X.) become necessary.

Another important matter is the determination of the relative values of wood and iron, or wood and steel, when they act together in resisting longitudinal bending. So long as the strains put upon the materials do not surpass the limits of elasticity of the wood—a condition which is fulfilled in nearly all cases—it is a fact, ascertained by experiment, that the wood will act with the metals and lend them valuable assistance. This is very advantageous to the structural strength of ships of all classes, in which iron stringers or ties are used on

the decks and elsewhere, with wood planking over them. In composite ships also, with a wood skin worked on iron ribs, or in sheathed iron ships, wherein wood planks are worked outside the iron plating in order to receive zinc or copper sheathing, this combined action of wood and iron is of great value. The late Professor Rankine suggested some years ago that a fair allowance, averaging the various strengths of the timbers used in shipbuilding, would be to consider wood equivalent to *one-sixteenth* of its sectional area of iron; and this is the allowance usually made in determining the effective sectional areas for the portions of the deck-flanges (A, B, C, in Fig. 99), representing the wood planking, or for other parts where iron and wood act together. In the following chapter this matter will be further discussed.

When the equivalent girder has been drawn, the next step is to estimate the strength of the midship section thereby represented; and this is done exactly in the same manner as if the girder were the cross-section of a long beam, subjected to the same bending strains as those to which the ship is subject. The comparison of a ship tending to hog or sag to a beam is a very old one, having been made by some of the earliest writers on the theory of naval architecture. Like many other suggestions, this was not made use of to any great extent until the introduction of iron shipbuilding; and the late Sir William Fairbairn did much towards establishing the practice of treating a ship as a hollow girder, so far as longitudinal bending is concerned. Readers familiar with mathematical investigations of the strength of beams will not require any further explanation respecting the use made of the equivalent girder; but there may be some not acquainted with these investigations, and to assist such in understanding the conclusions stated farther on, a brief explanation will be given of the principal steps by which the strength of a beam may be calculated.

Fig. 101 shows the side view and section of a flanged beam, which is bent by the action of the downward pressures P, P and the upward pressure Q. When it is thus bent, the convex upper side AB must have become elongated, as compared with its length when the beam was straight; whereas the concave under side CD must have been shortened. Hence at some intermediate part—suppose at EF—there will be found a surface which is neither stretched nor compressed, but maintains the same length which it had when the beam was straight. The surface EF is termed the “neutral surface”; all parts of the beam lying above

it are subject to tensile strain, all parts below are subject to compressive strain. In the sectional drawing of the beam, ef corresponds to EF , and is termed the *neutral axis* of the cross-section. On the neutral surface EF , let any two points ab be taken. When the beam is bent, the corresponding length on the upper surface is shown by cd , and that on the lower surface by gh ; the figure $cgld$ therefore represents the shape into which the bending of the beam distorts that part which was of the uniform breadth ab throughout the depth of the beam, before it was bent. For any layer in the beam the elongation or compression produced by the bending varies directly as the distance of that layer from the neutral surface. Within the limits of elasticity of the material, the elongation or compression also varies directly as the strain applied; that is to say, a bar of the material will stretch *twice* as much with a given weight suspended to it as it does with half that weight suspended; and so on. Hence it will

FIG. 101.

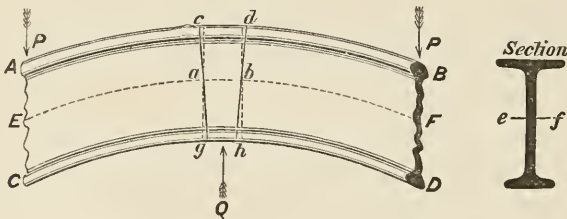

be seen that in a bent beam the stress on each unit of sectional area in a cross-section such as that in Fig. 101, or any other form of section, varies directly with the distance of that unit from the neutral axis ef . At the upper surface AB the stress will be twice as severe as it is midway between AB and EF , and the tensile strain at AB bears to the compressive strain at CD the same ratio as the distance of AB from EF bears to the distance of CD from that surface.

The question thus becomes important, What governs the position of the neutral axis? The answer is very simple. It is coincident with the *centre of gravity* of the cross-section of the beam, supposing (as may fairly be done) that the external forces P , P , Q act perpendicularly to the surface EF . This follows directly from the consideration that the sum of all the tensile forces developed on any cross-section of the beam must equal the sum of the compressive forces. The neutral surface of the beam contains the centres of gravity of all the cross-sections;

and this condition holds for all forms of cross-section, and all variations in form at different parts of the length; the preceding remarks containing no assumption that the beam is of uniform cross-section throughout its length. When the form of the cross-section of any beam is given, the above stated property enables the position of the neutral axis to be determined easily.

One further step remains to be explained. At any cross-section of the beam in Fig. 101 (say, at the middle of the length) the external forces (P and Q) give rise to a bending moment the value of which is easily ascertained. The effect of this moment is seen in the curvature of the beam; but it may be asked by what moment is the moment of the external forces balanced. Obviously it must be balanced by the moment of the internal forces (*stresses*, as they have been termed) developed by the elongations and compressions; each of these stresses may be considered as a force acting perpendicularly to the plane of the cross-section, and having for its fulcrum the neutral axis. And in this resistance to the external forces the internal forces all co-operate, from top to bottom of the beam. The total moment of these internal forces, about the neutral axis for any cross-section, is easily determined. It has been remarked that the stress on each unit of sectional area varies directly as its distance from the neutral axis. Let it be assumed, therefore, that under the action of certain external forces, a stress of s lbs. is experienced by a *square inch* of sectional area at *one inch* distance from the neutral axis. Then the corresponding stress on a square inch of sectional area at a distance y inches from the neutral axis will be expressed by the equation

$$\text{Stress} = s \cdot y \text{ lbs.}$$

The moment of this stress about the neutral axis equals the product of its amount by the distance y . That is

$$\text{Moment of stress} = s \cdot y^2 \text{ (inch-pounds).}$$

This last expression holds good for each square inch of sectional area. Hence for any cross-section of the beam

$$\begin{aligned} \text{Moment of resistance} &= \text{Sum of moments of the} \\ &\quad \text{stresses on each unit} \\ &\quad \text{of sectional area :} \\ &= \Sigma (s y^2 \cdot \delta A) \\ &= s \cdot \Sigma (y^2 \cdot \delta A) = s \cdot I. \end{aligned}$$

where δA is an element of the sectional area at a distance y from the neutral axis; and Σ is the sign of summation for all such

elements making up the total cross-sectional area A . The sum of all these products ($y^2 \cdot \delta A$) is termed the "moment of inertia" (say I) of the cross-section, about the neutral axis; and hence it follows that the moment of resistance may be succinctly expressed as the product of the stress on a unit of sectional area at a unit of distance from the neutral axis into the moment of inertia. This moment of inertia depends upon the size and form of the cross-section; the stress (s) at distance unity from the neutral axis depends, for a given cross-section, upon the magnitude of the moment of the external forces producing bending in the beam. Finally it should be noted that the foregoing equations hold good only when the maximum stress experienced by the material in the cross-section does not exceed the "elastic limit" (see page 386).

The upper and lower surfaces of any cross-section of the beam are those which are subjected to the greatest stresses, being most distant from the neutral axis. If h_1 and h_2 are the respective distances of these surfaces from the neutral axis, and p_1 and p_2 the corresponding stresses per unit of area (say per square inch); then from the foregoing expressions we have for any cross-section

$$s = \frac{p_1}{h_1} = \frac{p_2}{h_2} = \frac{\text{Moment of Resistance}}{\text{Moment of Inertia (I)}}.$$

But this moment of resistance to bending must balance the bending moment produced by the external forces, such as P and Q in Fig. 101. Hence finally if M = bending moment of the external forces, about any cross-section of a beam,

$$s = \frac{p_1}{h_1} = \frac{p_2}{h_2} = \frac{M}{I}$$

are equations determining the maximum stresses p_1 and p_2 , when the other quantities are known. The moment of inertia I is proportional to the product of the area of the cross-section into the *square* of the depth of the beam; whereas the distances h_1 and h_2 are proportional to the depth. Hence the ratio of the products of the sectional areas by the depths of two beams of the same material and similar cross-section, is a measure of their relative strengths to resist bending moments.

From the foregoing general expressions a few important deductions may be made. With a given sectional area, and a certain material, changes in the forms of cross-sections of beams may largely influence the moment of inertia, and therefore influence the resistance to bending. The *flanged* form of beam shown in Fig. 101 is thus seen to have great advantages, as

regards the association of strength with lightness; for the material thrown into the flanges is at a considerable distance from the neutral axis, and the moment of inertia is consequently increased. The vertical web must retain sufficient strength to keep the flanges at their proper distance apart and to efficiently connect them. When this has been done, all the rest of the available material should be thrown into flanges, and in lattice girder beams and bridges the principle receives its fullest development.

Reverting to the equivalent girder for a ship (Fig. 99), it is possible to make use of the foregoing general principles in order to compare the relative importance of different parts of the structure, as measured by their resistance to longitudinal bending. The most important parts are the upper flange A and the lower D; the flange C, corresponding to the lower deck, lies so close to the neutral axis (*mn*) as to be of little assistance. The flange B is of much more service, but cannot compare in importance with A. The web EE, formed by the side plating or planking is mainly useful, when the vessel is upright, in forming a rigid connection between the flanges and enabling them to act together; but on account of their distance from the neutral axis, the parts of EE lying nearest to A and D offer considerable resistance to bending. When the vessel is inclined, the conditions are somewhat changed; she then resembles a hollow girder set angle-wise. The parts contributing most to the longitudinal strength will then be the upper deck, the sheer-strakes and side plating adjacent to that deck, and the bottom in the region of the bilges; but the arrangements which are efficient when the vessel is upright will also contribute greatly to the efficiency when she is heeled over to the most considerable angles likely to be reached in rolling. Vessels are sometimes thrown over on to their beam ends, but this is a very exceptional position, and need not have much influence upon the distribution of the material. There is good reason to believe that a ship which is strong enough to resist longitudinal bending moments when she is upright will be sufficiently strong in every other position. By general consent, therefore, the upright position is assumed in the construction of the equivalent girder, and most care is bestowed to meet the bending strains incidental to that position.

Hogging, it will be remembered, is the change of form produced by the ends of a ship dropping relatively to the middle, the keel becoming arched upwards. The conditions of strain are then similar to those in the beam, Fig. 101; the upper parts of

the structure being subjected to tensile strains, the lower to compressive strains, and the division between the two being marked by a neutral surface. Sagging is the converse case where the middle drops relatively to the ends; the keel becoming arched downwards, the upper parts of the structure being subjected to compressive strains, and the lower to tensile strains, the change of strain being marked by a neutral surface, not agreeing in position with that for hogging. It will indeed be evident, from what has already been said respecting the difference between the total and effective sectional areas of parts of the

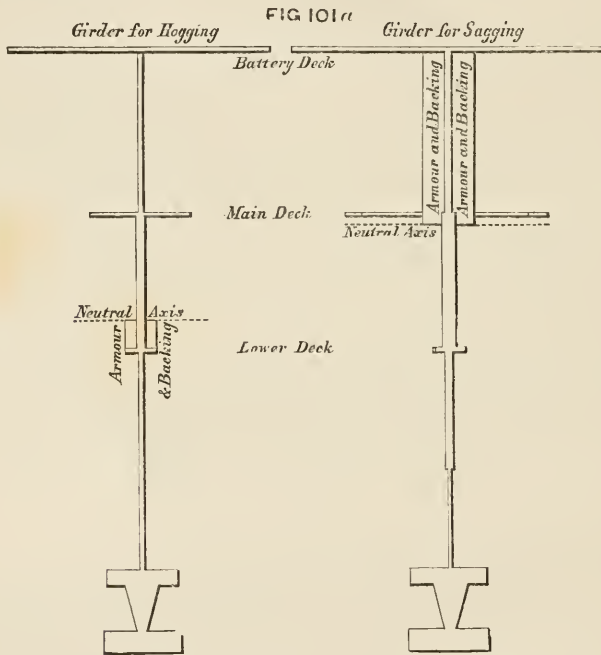

structure, that, strictly speaking, the equivalent girder for hogging strains must be different from that for sagging strains; although in practice the two are sometimes treated as identical (see page 330). But while the sectional areas of the upper and lower flanges A and D of the equivalent girder in Fig. 99 change both their absolute and relative values, according as hogging or sagging strains have to be resisted, it is still true, for both hogging and sagging, that these are the two parts of the structure which are of the greatest assistance in resisting change of form. Their joint action is secured by means of the web formed by the skin.

An example, taken from an actual ship may be of service both as an illustration of the foregoing remarks respecting the relative importance of the several parts of the structure, and as an indication of the simplicity of the calculations for the equivalent

CALCULATION OF MOMENT OF INERTIA OF SECTION WHEN THE SHIP IS UNDER A HOGGING STRAIN.

Total depth of girder = 37·5 Feet.
 Neutral axis below top = $h_1 = 19·3$
 Neutral axis above bottom = $h_2 = 18·2$

Parts of Structure.	Effective Sectional Areas = A.	Distance of Centre of Gravity from Neutral Axis = h.	Squares of Distances = h^2 .	Products $A \times h^2$.	Depths of Webs in Girder = d.	Squares of Depths = d^2 .	Products $\frac{1}{2} \times A \times d^2$.
	Sq. ins.	Feet.			Feet.		
Upper deck flange	155·1	19·2	368·6	57,170	—	—	—
Main deck flange	654·1	10·6	112·4	73,521	—	—	—
Lower deck flange	117·2	3·6	13·0	1,524	—	—	—
Wing passage bulkhead (part)	51·0	5·5	30·2	1,540	9·0	81	344
Coal bunker bulkhead (part)	14·0	1·4	2·0	28	2·8	7·8	9
Shelf plate	24·7	·85	·7	17	—	—	—
Skin plating	685·1	10·1	102·0	69,880	18·4	338·6	19,331
Bottom plating above neutral axis	19·0	·4	·2	4	·8	·6	1
Coal bunker bulkhead (lower part)	37·8	3·2	10·2	386	6·3	39·7	125
Wing passage bulkhead (lower part)	63·4	4·6	21·2	1,344	9·3	86·5	457
Bottom plating above bilge	401·0	7·5	56·3	22,576	12·7	161·3	5,390
Bottom flange	889·0	15·8	249·6	221,894	5·5	30·2	2,237

449,884
 27,894

$I = \text{Moment of inertia} = 477,778$

When the ship is on a wave crest—

$M = \text{Bending moment at section just outside battery} = 28,000 \text{ foot-tons.}$

Maximum tensile strain on upper part of section }
$$= \frac{28,000 \times 19·3}{477,778} = 1·13 \text{ tons per square inch.}$$

Maximum compressive strain on lower part of section }
$$= \frac{28,000 \times 18·2}{477,778} = 1·07 \text{ tons per square inch.}$$

girders of ships. That selected is one of the investigations made by the Author's pupils at the Royal Naval College for a broad-side iron-clad frigate resembling the *Invincible* class in the Royal Navy. Fig. 101a represents the equivalent girders for this ship

CALCULATION OF MOMENT OF INERTIA OF SECTION WHEN THE SHIP IS UNDER A SAGGING STRAIN.

Total depth of girder	=	Feet. 37·5
Neutral axis below top	= h_1	= 15·9
Neutral axis above bottom	= h_2	= 21·6

Parts of Structure.	Effective Sectional Areas = A.	Distance of Centre of Gravity from Neutral Axis = h .	Squares of Distances = h^2 .	Products. $A \times h^2$.	Depths of Webs in Girder = d .	Squares of Depths = d^2 .	Products $\frac{1}{2} \times A \times d^2$.
	Sq. ins.	Feet.			Feet.		
Upper deck flange	202·9	15·8	249·6	50,644	—	—	—
Main deck flange	777·8	7·1	50·4	39,201	—	—	—
Lower deck flange	148·6	·2	·04	6	—	—	—
Skin plating (part)	681·5	7·9	62·4	42,526	15·8	249·6	14,175
Armour and backing	1657·5	3·2	10·2	16,905	6·5	42·3	5,843
Wing passage bulk-head	43·8	3·2	10·2	447	6·5	42·2	154
Coal bunker bulk-head	65·0	6·6	43·6	2,834	11·9	141·6	767
Shelf plate	46·3	5·2	27·0	1,250	9·2	84·6	326
Skin plating (part)	24·7	2·6	6·8	168	—	—	—
Bottom plating above bilge	92·4	1·3	1·7	157	2·6	6·8	52
Bottom flange	360·1	11·0	121	43,572	13·6	185	5,552
	767·2	19·2	368·6	282,790	5·6	31·4	2,007
				480,501			28,876
				28,876			
				<u>I = Moment of inertia = 509,377</u>			

When the ship is astride the wave hollow—

M = Bending moment at section just outside battery = 47,120 foot-tons.

	Foot-tons.	Feet.	
Maximum tensile strain on lower part of section	} = $\frac{47,120 \times 21·6}{509,377}$	= 2 tons per square inch.	
Maximum compressive strain on upper part of section			} = $\frac{47,120 \times 15·9}{509,377}$

when subjected to hogging and sagging strains. The armour is supposed to be efficient only against compressive strains, which is an assumption on the side of safety. In estimating the effective sectional areas of other parts of the structure the rules explained on page 330 have been followed. Further explanations of the detailed calculations appended will scarcely be required, beyond the statement that the bending moments (M) for the extreme positions of support, on wave-crest and astride wave-hollow, were estimated in the manner explained in Chapter VIII., and are introduced in the calculations for the purpose of determining the corresponding maximum stress on the top and bottom respectively.

From the preceding explanations and illustrations it will be obvious that the ratio of the *depth* of a ship to her *length* should exercise great influence upon the provision of longitudinal strength. The moment of resistance of an equivalent girder section like that in Fig. 99 has been shown to be very largely influenced by the depth; while the maximum longitudinal bending moment for a ship is expressed in terms of the product of her weight into the length. Broadly speaking, the shallower a ship is in proportion to her length the greater should be the amount of material contributing to the longitudinal strength; and not unfrequently when the hull-proper is extremely shallow recourse is had to some device for virtually increasing the depth as is described by Figs. 105 and 106, page 361. War-ships of nearly all classes are of much greater depth in relation to their length than merchant ships; and this fact, taken in connection with their structural arrangements, explains the smaller strains to which the material in war-ships is subjected. It must not be supposed, however, that increase in depth *per se* necessarily leads to a diminution in strains; on the contrary, cases may occur where an increase in depth obtained by building a light continuous superstructure, upon a comparatively strong hull, actually leads to an increase in the maximum strain brought upon the material most distant from the neutral axis.* The reasons for this are obvious enough, on consideration of the fundamental equations for the strength of beams, given on page 334; but the following example may assist some readers. A belted ironclad having a depth of 42 feet from the flat keel to the spar-deck amidships, had a strongly-plated protective deck, 16 feet below the spar-deck; and calculations were made for the purpose of ascertaining the maximum strains likely to be brought (1) upon the material in the spar-deck when the sides were intact, and (2) upon the material in the protective deck when the sides above that deck were shot away in action, so that the protective deck became the top of the girder. Under hogging strains the following were the results:—

I. With sides and spar-deck intact,

Total depth of girder = 42 feet

Neutral axis below top = $23\frac{1}{3}$ „

* Readers desirous of following out this subject may turn with advantage to a Paper by Mr. Purvis in the *Trans-*

actions of the Institution of Naval Architects for 1878.

$$\left. \begin{array}{l} \text{Moment of inertia of} \\ \text{equivalent girder .} \end{array} \right\} = 376,000.$$

Using the same notation as before, for a given bending moment (M).

$$\left. \begin{array}{l} \text{Maximum strain on material} \\ \text{in spar-deck} \end{array} \right\} = M \times \frac{h_1}{I} = M \times \frac{23\frac{1}{3}}{376,000}$$

$$= M \times \frac{1}{16,100} \text{ (nearly).}$$

II. With sides and spar-deck damaged,

$$\text{Total depth of girder} = 26 \text{ feet}$$

$$\text{Neutral axis below top} = 11 \text{ ,,}$$

$$\left. \begin{array}{l} \text{Moment of inertia of} \\ \text{equivalent girder .} \end{array} \right\} = 210,000$$

$$\left. \begin{array}{l} \text{Maximum strain on material} \\ \text{in protective deck . . .} \end{array} \right\} = M \times \frac{11}{210,000}$$

$$= M \times \frac{1}{19,100} \text{ (nearly).}$$

Hence it is seen that the diminution in the depth produced by breaking the continuity of the lightly constructed top sides, upper deck and spar-deck, actually resulted in a diminution of tensile strain in the ratio of 191 to 161. This diminution in tensile strain was accompanied in this case by an increase in the compressive strain on the bottom plating, the value of which may be easily ascertained, if desired, from the foregoing data. Space will not permit us to carry the investigation farther. It must suffice to add that although our illustration has been taken from war-ships, the point raised is chiefly important in merchant ship construction, seeing that the adoption of continuous spar-decks or awning-decks is now so common, and that the bottoms are usually much stronger than the upper decks, under the principal hogging strains which have to be resisted.

Furthermore it is necessary to remark that the ratio of *length to breadth* must be considered in adjusting the amount of longitudinal strength to be given to a ship. For the upright position the breadth influences the effective sectional areas of the decks, bottom plating or planking, &c., included in the equivalent girder. For the extreme "beam-ends" position the breadth becomes the depth. For any intermediate or inclined positions the breadth affects the depths and strengths of the corresponding equivalent girder sections.

Equivalent-girder calculations are usually made for cross-

sections at or near the middle of the lengths of ships; because (as explained in the previous chapter) the severest hogging and sagging moments, corresponding to exceptional positions of support for ships afloat or ashore, are usually experienced by these cross-sections. Similar calculations may, however, be made for other cross-sections lying towards the bow or stern, the moment of resistance of the equivalent girder for any section being compared with the bending moment experienced by that cross-section, which bending moment is ascertained from the corresponding ordinate of curves such as MMM in Fig. 86, page 291. Cases occur where the presence of large hatchways or openings in the deck, or peculiarities in the structural arrangements,—such as the discontinuance of protective plating at some cross-section in a central citadel or battery ship—lead to greater tensile and compressive strains being brought upon the material at cross-sections considerably distant from the middle of the length, than are experienced by the material at the midship section. No general law holds good in these matters, but each case must be separately investigated. Broadly speaking, the diminution of the bending moments from the middle of a ship towards her ends, renders possible some diminution in the strength of other cross-sections as compared with the strength of the midship section. And although local strains and other considerations interfere with the application of any general rule, the fullest association of lightness with strength requires that the shipbuilder shall bestow attention upon the *longitudinal distribution* of the material in a ship.

In deciding upon what reductions of scantlings or thicknesses are possible in the parts lying towards the ends of a ship, the builder has to note two important facts. First, the gradual narrowing of the ship towards the extremities is in itself a cause of decrease in the strength of cross-sections; it lessens the sectional areas of the planking or plating on decks, sides, and bottoms; and not unfrequently, owing to the reduction in girths, there are fewer longitudinal stiffeners at the ends than amidships. Second, when a ship is very considerably inclined, the narrowing of the decks produces a virtual decrease in the *depth* of the equivalent girder sections; this may be regarded as the source of a still further loss of strength to the cross-sections lying towards the extremities, which is not in operation when the ship is upright. For the upright position the depth of the equivalent girders then remains practically constant for all cross-sections throughout the length.

These facts, taken in connection with local requirements, have led shipbuilders to make only a small decrease in the thicknesses of the planking, plating, &c., forward and aft as compared with the thicknesses used amidships. In wood ships the thickest outer planking, the wales, is reduced in thickness towards the bow and stern. In iron ships of the mercantile marine it is customary to maintain the midship thicknesses throughout one-half the length, and at the extremities to reduce the thickness of the outer skin by about $\frac{1}{16}$ inch, besides either narrowing the stringers on the decks or decreasing the thickness of stringers and deck plating. Vessels framed on the longitudinal system have, in addition, the depths of their longitudinal frames decreased towards the extremities, and as the girths of the sections become less, the practice is to stop short one or more of the longitudinals. These are the main changes that need now be mentioned; they do not effect any considerable difference in the scantlings at the extremities as compared with those amidships and although some writers have recommended much more marked differences between the central part of a ship and her ends, the general feeling and experience of shipbuilders have not gone in this direction.

Local requirements, as remarked above, exercise a very great influence on the longitudinal distribution of the material, often in a direction exactly opposite to that in which the consideration of the strength of the ship as a hollow girder would lead. Many examples of this will occur to the reader who has an acquaintance with the details of shipbuilding; only two or three of the most important can now be mentioned. The plating near the stern in a single screw steamer, from the girder aspect of the case, might be made as thin as any plating on the ship, but as a matter of fact it is as thick as any, the reason being that the local strains due to screw propulsion require strong plating to be fitted between the stern-post and the stuffing-box bulkhead next before it. Passing to the other extremity of an ironclad ship, another instance is found. In order to meet the local strains produced by the chafing of the cables, and rubs or blows of the anchors on the bows, it is usual in ships of the Royal Navy to double the plating for some distance; and this additional thickness, of course, adds much to the strength of a ram-bow; but here again, reasoning from the girder, a minimum thickness of plating should suffice.

Very similar remarks may be made respecting the *vertical distribution* of the material in the cross-sections of ships. Reasoning

exclusively from the analogy of the equivalent girder it will be obvious that it would be advantageous to decrease the amount of the material near the neutral axis; which could be best done by thinking the skin-plating or planking at that part. Some slight reductions in thickness have been made in many cases, but there are other considerations which require to be taken into account before proceeding far in this direction. Ships frequently occupy inclined positions, and then side plating or planking which is included in the "web" of the equivalent girder for the upright position, may be so placed as to be capable of yielding the greatest assistance to the structure. On this account in iron and steel ships the common practice is to keep the greater part of the skin-plating of uniform thickness, fitting a few thicker strakes on the bottom below the bilges where the severe local strains due to grounding are principally felt, and thickening or doubling the sheer-strakes. Wood ships usually have their *thickest* planking in the neighbourhood of the middle of the depth, where it can be least effective against longitudinal bending strains when the ship is upright; but these wales are probably the outgrowth of the rubbing strakes formerly fitted near the main breadth, and they also form strong ties above and below the lines of ports in many classes of wooden war-ships, thus restoring, to some extent, the loss of strength due to the want of continuous longitudinal planking in wake of the ports. Moreover, when vessels approach the "beam-end" position, the wales are of considerable assistance in resisting longitudinal bending.

Modern war-ships have their structural arrangements very much controlled by the necessity for protecting certain parts by armour. The general considerations based upon the comparison of a ship to a girder are therefore, to a large extent, overruled, material being massed in flanges formed by decks near the middle of the depth, or thrown into the centre of the web of the girder for the upright position, instead of being added to the upper part or to the upper deck. For instance, to increase the resisting power of the target formed by the armoured side, the skin-plating behind the armour is made about twice as thick as the bottom plating, although its situation is frequently not very favourable to its efficient contribution of longitudinal strength. Nor, to give one other example, do the strongly-plated decks, fitted some 5 or 6 feet above water (as in the belted ships) or an equal distance below water (as in the central-citadel type), contribute to the longitudinal strength at all to the same extent as the same weight of iron differently distributed might do. The armour plating itself

also, even when arranged and fastened with the utmost care, must be regarded rather as a load carried by the structure than as adding much to the longitudinal strength.

From the preceding remarks it will appear that although the comparison of a ship to a girder in her resistance to longitudinal bending is of great service to the shipbuilder, it only holds good within certain limits. Keeping this in view we now propose to sketch the character of the principal structural arrangements,

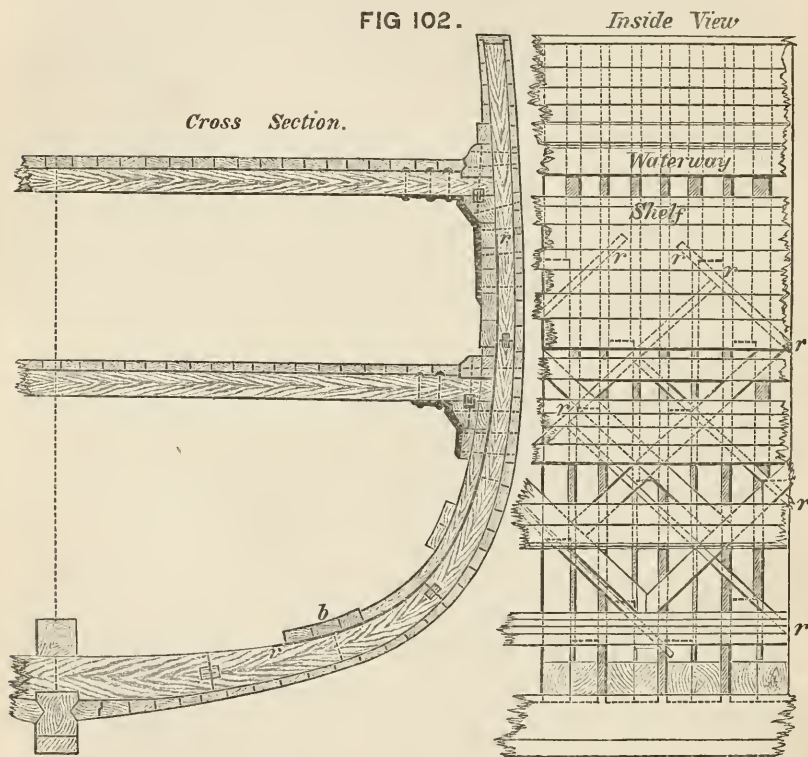

which supply longitudinal strength to different classes of ships, and to contrast the relative efficiency of those arrangements. Wood ships, iron and steel ships, and composite ships will come under review, as well as armoured ships; but it must be understood that no endeavour will be made to describe the structural details of any class; for these the reader must turn to works on shipbuilding. To illustrate the contrast between these classes, and to assist our explanations, Figs. 102, 103, 104, and 104a have been prepared. The former shows, in cross-section and

inside elevation, the construction of a wooden ship according to the former practice of the Royal Dockyards. Fig. 103, page 346, shows, in cross-section, the construction of an ordinary iron merchant ship. Fig. 104, page 351, shows, in cross-section, the construction of an ironclad ship of modern type. Fig. 104a, page 354, shows in cross-section, the construction of an iron or steel merchant ship, with cellular double bottom. As we proceed, repeated references will be made to these figures, and their principal features will be noted in connection with the contribution of individual parts to the general structural strength.

First, as to the upper flange in the equivalent girder for a wood ship. The parts ordinarily included are as follows: the deck-planking, allowing for its effective area in the manner explained above; and the thick "water-way" fitted upon the beam ends (see Fig. 102). Such a flange is much less strong against the tensile strains brought upon it by hogging than it is against the compressive strains due to sagging; the effective area against tensile strains being less than three-quarters of that against compressive strains. It is a matter of common experience that, under severe hogging strains, signs of working and weakness display themselves in the upper works of wood ships. In order to add strength to the upper deck, iron stringers and plating were worked under the wood planking in many of the later wood-built ships of the Royal Navy. Examples of this addition will be found in the converted ironclads of the *Caledonia* class, and in the largest class of corvettes.

In iron, steel or composite ships the upper flange of the equivalent girder resembles that described for the later wood ships. Fig. 103 shows the arrangement; the iron stringer plates on the beam ends being drawn in strong black lines under the wood planking. These stringers should always be strongly secured to the uppermost strake of the side plating of an iron ship (termed the "sheer-strake"), which is often made thicker or doubled, for the purpose of increasing the longitudinal strength. Composite ships also, although they have not an iron skin, are usually fitted with a sheer-strake. At the outset of iron shipbuilding, the use of deck-stringers was not general; but as the sizes of ships increased, the necessity for adding to the longitudinal strength of the upper decks became apparent, and stringers were adopted. The breadths of these stringers have been increased as still larger vessels have been constructed; and at the present time it is very common to find the whole, or a great part, of the surface of the upper and main decks in large iron or steel steam-ships covered

with plating. These complete or partial iron or steel decks, fitted under the wood planking, are most valuable additions to the structural strength, and have corrected weaknesses formerly too common in the upper parts of iron ships. Complete iron and steel upper decks have been fitted, from the first, in the iron-built armoured ships of the Royal Navy, and have proved thoroughly efficient. In the *Great Eastern* the exceptional strength required

FIG 103.

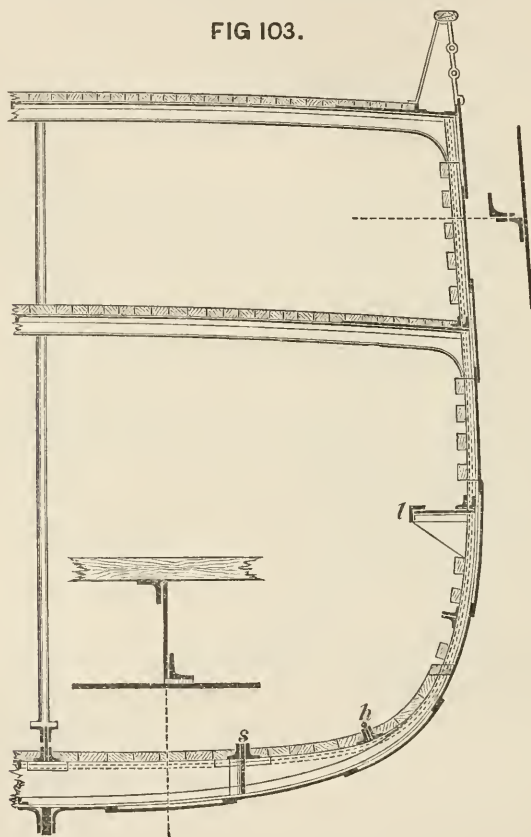

has been provided by a very unusual construction of the upper deck. This is a cellular structure formed by two strong iron skins worked above and below deep girders running longitudinally. Besides the unusually strong plating, the strength of the girders in this ship therefore comes into play against hogging or sagging strains; whereas the *transverse* beams fitted almost without exception in other ships can lend no assistance to the decks against such strains. In the largest vessels afloat, except-

ing the *Great Eastern*, the simpler and lighter arrangement of iron or steel decks, worked upon transverse beams, under the planking is, however, found to answer every purpose.

Next, as to the *lower flanges* in the equivalent girders of the different classes of ships; this is a less simple case than the preceding.

In wood ships the parts included in the lower flange vary considerably, according as hogging or sagging strains have to be resisted. The bottom planking up to the bilge, the keel, keelson, and binding strakes (*b*, Fig. 102) are all effective, although not equally effective, against both hogging and sagging strains. It is a common practice to fill in the openings between the ribs, from the keel up to some distance from the bilge; and this has a twofold advantage. In case of damage to the bottom planking the fillings keep the water out of the hold; and, moreover, when the vessel tends to hog, and her bottom is brought under compression, the lower part of the frames is made into a practically solid mass of timber, the fillings offering great resistance to any change of form. When sagging takes place, and the bottom is brought under tension, the fillings can lend no such help to the pieces lying longitudinally, and the difference is very considerable. It is, however, noteworthy that in ordinary wood ships the severest longitudinal bending moments are those tending to produce hogging, a fact which makes the use of fillings of the greater value. To assist the bottom in resisting the tensile strains due to sagging, iron stringers have been fitted in some few cases in lieu of the ordinary thick binding strakes; but this arrangement is not so valuable as the use of iron strengthenings to the upper deck.

In ordinary iron or steel ships the bottom flange of the girder is made up of the keel, keelson, side keelsons (*s*, Fig. 103), hold stringers (*h*), and the bottom plating. These are all effective against both hogging and sagging strains; and, as already explained, the difference in the sectional areas, effective against tension and compression respectively, is not nearly so marked as in the case of the corresponding part of a wood ship. The transverse frames, or ribs, of the iron or steel ship are 20 inches or 2 feet apart, there being nothing corresponding to the fillings of the wood ship. Fig. 103 by no means represents the universal practice of shipbuilders as to the arrangement of the longitudinal stiffeners to the bottom plating. There are very many varieties of side keelsons, hold stringers, keelsons, keels, &c., some builders preferring one arrangement, other builders preferring another

arrangement. But they have one feature in common. The *main frames* lie transversely like those of a wood ship, and do not contribute to the longitudinal strength, whereas the longitudinal pieces are supplementary or subordinate to the transverse framing, and are either fitted in between the ribs (like *s*), to secure a direct connection with the bottom plating, or over-ride the ribs (like *h*, Fig. 103).

For wood ships it is practically a necessity to place the ribs transversely, and in the earliest iron ships the arrangements of wood ships were naturally imitated to a considerable extent. The moderate size of the earlier iron vessels rendered almost unnecessary any longitudinal strengthenings to the bottom other than were furnished by the engine and boiler bearers, fitted primarily as supports to the propelling apparatus. But as the sizes of ships increased, the longitudinal strengthenings to the bottom were multiplied, and in some cases the bottom was thus strengthened, while the top flange of the girder was left almost uncared for, the result being a great disproportion between the strength of the top and bottom flanges. There are, of course, many local strains to be borne by the bottom of a ship—such as those due to grounding, the carriage of cargo, and possible concentration of weights—which are not paralleled by any strains that have to be borne by the decks; but to give greatly disproportionate strength to either flange involves a bad distribution of the material. The recent use of iron and steel upper decks and broader stringer plates has partially corrected an evil formerly prevalent in merchant ships, but the upper flange is still commonly made much weaker than the lower. If ships fail, they usually yield to hogging strains; but cases have occurred where the upper flange of the equivalent girder has yielded to the compressive strains incidental to sagging. The shallow-draught steam-ship *Mary*, mentioned on page 327 is alleged to have foundered in consequence of the upper deck crushing up when she met with heavy weather in the Bay of Biscay on her passage to the station for which she was designed.

There is no dispute but that the combination of strength with lightness would be more efficiently secured if the main frames of iron and steel ships were made longitudinal instead of transverse at least for the parts below the bilges. The continued use of the old system of framing is mainly due to the greater cheapness of construction, rendered possible in consequence of the familiarity of the workmen with this mode of building, and the greater rapidity with which the work can be carried on. More-

over, by fitting strong bottom plating, combined with numerous intercostal side keelsons, hold-stringers, &c., sufficient longitudinal strength can undoubtedly be given to the bottoms of even the largest ocean steamers, and the additional weight involved is not thought generally to be of so much importance as to render it desirable to incur the greater cost of construction of the longitudinal system of framing. Since 1887 there has, however, been a remarkable extension of the "cellular" system of construction for iron and steel merchant ships, illustrated by Fig. 104*a*; and the experience gained with these vessels has done much towards removing the objections previously urged against longitudinal framing for merchant ships.

Composite ships resemble ordinary iron ships in having the main frames transverse; and the bottom flanges of their equivalent girders differ from those of the iron ships chiefly in that they include wood keels and bottom planking. The latter especially loses, as compared with iron plating, in its resistance to the tensile strains due to sagging moments. No equally intimate connection can be made between the intercostal side keelsons of a composite vessel and the bottom planking, as are possible between such keelsons and the bottom plating of an iron ship. Nor can the composite ship have the help of fillings between the frames like those of a wood ship. These are the only points of difference that need be mentioned.

Although the transverse system of framing has been so generally adopted in the mercantile marine, there are not a few ships in which longitudinal framing occupies the chief place. The *Great Eastern* is the most notable example, and her structural arrangements, due to the joint labours of the late Mr. I. K. Brunel and Mr. Scott Russell, furnish good evidence of the superiority of the longitudinal system.* Other and much smaller merchant ships have been built on very similar principles; and in all the iron-built ironclads of the Royal Navy great prominence is given to longitudinal framing. Such framing is of the greatest advantage in the lower parts of ships lying below the lower deck. The comparatively flat surfaces of the bottom plating below the bilge are best stiffened against buckling by longitudinal

* For much interesting information concerning the construction of this ship, and her predecessors, the *Great Western* and *Great Britain*, see the life of Mr. Brunel, published by his son.

It is evident from the details therein given that, at a very early period after the introduction of iron ships, Mr. Brunel perceived the great advantages attaching to longitudinal framing.

frames, which form strong girders well secured to the bottom plating, and contribute to the effective area of the lower flange of the equivalent girder for the upright position. At the bilge there is usually considerable transverse curvature in the bottom plating, a fact which gives it great stiffness in itself against buckling under compressive strains, due either to hogging moments or to the concentration of surplus buoyancy; hence immediately at the bilge longitudinal frames are not so much required for the purpose of preventing buckling. Very frequently external bilge-keels are fitted just at this part of the bottom, forming good stiffeners to the plating, besides adding their own sectional areas to the lower flange of the girder. Above the bilge, and below the lower deck, longitudinal frames are again of great use, especially in adding to the longitudinal strength when the ship occupies an inclined position, and is subject to hogging or sagging moments. When we reach the parts lying above the lower deck, other considerations enter and make the longitudinals of less importance; in fact, the decks themselves with their stringers, &c., form most efficient longitudinal stiffeners, and they are usually so close together as to render intermediate longitudinals unnecessary. Sometimes, where a lower deck does not extend throughout the whole length, but is broken for some reason, its stringer plate is continued in order to form a stiffener, as shown by *l*, Fig. 103. It may, however, be regarded as the rule that the decks need no aid from intermediate longitudinal frames, the only framing required in the upper parts of ships being vertical and transverse. Such framing stiffens most efficiently the almost upright side plating, gives facilities for attaching the beams to the side, and answers other purposes. The extent to which it is adopted must of course depend upon the special conditions of each class of ship. Widely spaced vertical frames suffice in the upper parts of the *Great Eastern*; whereas in armoured ships these frames are very closely spaced, in order to assist in strengthening the target formed by the armoured side. Fig. 104 illustrates the last mentioned case; below the armour, the main frames are longitudinal, as shown but behind the armour the principal frames are vertical, being spaced only 2 feet apart (see the section at *cd*). The longitudinal girders worked between the strakes of the wood backing are not fitted primarily with a view to increase the longitudinal strength of the structure, although they have this effect, but are intended to increase the resistance of the target formed by the side of the ship against penetration or damage by projectiles.

Looking a little more closely into the arrangements illustrated in Fig. 104, it will be evident that the lower flange of its equivalent girder includes the skin plating, both outer and inner, as well as the numerous and strong longitudinal frames. These frames, as already explained, are of great value in preventing buckling, and resisting the tensile strains due to sagging, even when there is only a single outer skin. But their efficiency in these respects

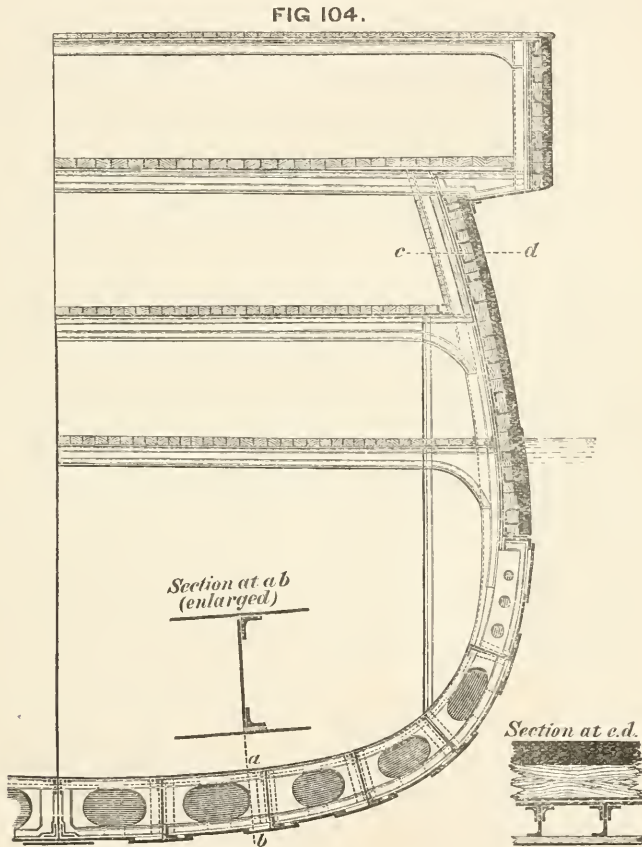

and the strength of the lower flange of the girder are both very greatly increased by the adoption of the inner skin plating, forming a double bottom. This cellular construction is shown by experiment to develop most efficiently the strength of a structure formed of wrought-iron plates and bars, any one of which, taken singly, has little strength to resist bending. It is unnecessary to repeat what has already been said respecting the

adaptability of double bottoms for water-ballast or the gain in safety due to the use of double bottoms, this being so great that, even if there were no gain in structural strength, the ship-builder would be fully justified in adopting the arrangement.

Although the longitudinal frames play such an important part in connecting the two skins and stiffening the bottom, their direct contribution to the moment of resistance of the equivalent girder section is not relatively great. This will appear more clearly on reference to the exemplar calculations for an armoured ship on pages 337-8. The inner and outer skins are the largest contributors to the moment of inertia of the lower flange, and the longitudinals might be left out of the calculation without seriously affecting the result. Their presence on the structure is, however, of great importance; for without them the joint action of the two skins in resisting bending moments would not be secured. Furthermore it must be noted that to give efficiency to longitudinal framing, frequent "sections of support" must be provided by means of transverse bulkheads or "partial bulkheads," as is further explained hereafter. Having made this provision, the amount to which the main longitudinal frames require to be reinforced by subordinate transverse frames, depends upon the necessities of local strength in the bottom (see page 313). In the armoured ships of the Royal Navy the "bracket-frames" are 4 feet apart, and this amount of stiffening to the bottoms is found sufficient to meet all the ordinary strains to which the ships are subjected during construction, launching, docking, or service afloat. In cases of grounding also, although these are rare in war-ships, this bracket-system of construction has stood the stress of service exceedingly well. The *Iron Duke*, for example, grounded twice on the China station, once on a soft bottom and secondly on a rocky bottom. On this second occasion the outer bottom was bulged in, the framing in the double bottom was bent and broken over a considerable length, but the inner bottom remained intact, and the ship was safely navigated to port after she was got off.

Since 1877 a remarkable extension of the use of cellular double bottoms has taken place in the mercantile marine. The change must be mainly attributed to the enterprise of a few leading shipbuilders, and to the support given to the movement by the professional officers of the Registration Societies. One great reason for this rapid progress is to be found, no doubt, in the more general recognition of the commercial advantages attending the use of water-ballast; the gain in safety has also

had some weight, and is becoming increasingly evident to ship-owners. It may fairly be supposed that the examples of the *Great Eastern* and the armoured ships of the Navy, had some influence upon the movement, as well as upon the character of the structural arrangements of recent merchant ships built with cellular double bottoms. Limits of space prevent us from attempting to trace in detail the various methods of construction adopted by different firms,* or to contrast these with the corresponding methods of construction in war-ships. All that can be done is to choose a good example of recent practice, such as is illustrated in Fig. 104a, and to sketch the main features.

Above the turn of the bilge the main frames are vertical and have the usual spacing, about 2 feet. At the turn of the bilge there is a continuous watertight longitudinal frame (AA, Fig. 104a), and upon this the vertical frames are stopped short, their heels being connected to the longitudinal by bracket-plates (B). The longitudinal AA has its outer edge connected by a continuous angle-bar to the bottom plating, while its inner edge is similarly connected to the inner skin plating; in this way the longitudinal forms a watertight side boundary to the ballast-tank, or cellular bottom. Within the double bottom the main frames are longitudinal as indicated on the section. The transverse framing consists of "gusset" or "bracket" plates, with angle-bars on their edges and ends connecting them to the two skins and the longitudinals; these bracket-frames are spaced 4 feet apart, just as the corresponding frames in the armoured ships are spaced (see Fig. 104). Intermediate between the bracket-frames, simple angle-bar transverse frames are fitted (as shown on lower section) to give additional support to the skin-plating, and to provide for taking the ground as merchant ships frequently have to do. Sometimes the bracket-frames are not fitted, plate-frames lightened with holes being used instead, and this plan is growing in favour. In certain parts of some large ships where special strength is required, the plate or bracket frames have been spaced only 2 feet apart; but this is not usually done. Another feature deserving to be noted in Fig. 104a is the use of deep transverse frames or partial bulkheads above the cellular bottom, at intervals of about 12 feet; and the combination therewith of two intercostal side-keelsons. The outline of these

* For these see Papers by Mr. Martell in the *Transactions* of the Institution of Naval Architects for 1877, and by Mr. John in the *Transactions* for 1880.

partial bulkheads is indicated by dotted lines on the section; and their value will be further explained hereafter.

From this brief explanation it will be seen that the cellular system now widely used for merchant ships, is very similar in principle to, though different in details from, the longitudinal

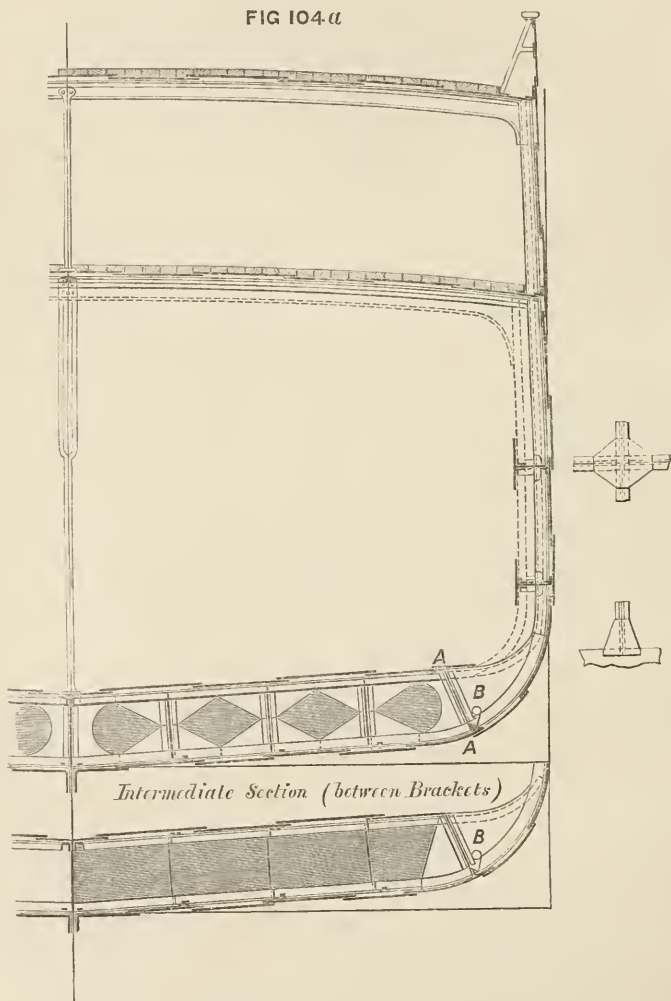

system previously described for armoured ships. The greater amount of support given to the bottom is a necessity in merchant ships, which have to take the ground. Experience has shown that a vessel can be built on this cellular system, and given all the advantages of a water-ballast tank, as well as greater safety,

with no greater weight of material than would be used in a vessel of the same dimensions built on the ordinary transverse system. The cost of workmanship in the cellular system is found to be somewhat greater than in the ordinary system; but this excess in cost will undoubtedly be decreased as experience is gained by the workmen. Cellular double bottoms necessitate the sacrifice of some of the hold-space as compared with the ordinary transverse system of framing without any provision for water-ballast. But as compared with other methods of forming water-ballast tanks, the cellular system is more simple and efficient, while it takes less away from the hold-space. One very common arrangement for water-ballast consisted in building upon the floors a series of longitudinal girders which carried an inner skin, extending across the ship from bilge to bilge, and connected in a watertight manner to the outer bottom plating. These ballast tanks, or partial double bottoms, answered fairly well, and the material used in their construction contributed somewhat to the general structural strength; but not nearly to the same extent as the material in the cellular bottoms. It is now not uncommon to find the cellular system applied throughout the whole length of the ship, in order to gain the greatest power of controlling the trim by the admission of water-ballast into the spaces near the extremities. In many cases, however, the double bottoms of merchant ships only extend over portions of the length; and in war-ships as already explained (page 25) the double bottom is usually stopped some distance short of the extremities.

Continuing the investigation of the equivalent girders for different classes of ships, attention must next be directed to the webs or vertical portions, marked EE in Fig. 99.

In ordinary wood ships the outside and inside planking is worked in one thickness, as shown in Figs. 100 and 102. The individual planks or "strakes" are comparatively narrow, the numerous butts and edge seams being caulked. This planking with the shelf-pieces under the beams, and the diagonal strengtheners, from the web of the girder. The ultimate strength of these parts against cross-breaking strains is no doubt ample in all or nearly all cases; and what has to be regarded is rather their strength to resist the *racking* strains which always accompany bending.

Reverting to the case of the beam in Fig. 101, it will be seen that, although the total of the tensile forces experienced by any cross-section equals the total of the compressive forces,

these two resultants act in opposite directions, and therefore tend to *rack* or distort the beam, this racking strain reaching its maximum at the neutral surface, and gradually decreasing to nothing at the top and bottom of the beam. So long as the beam is in one piece, or so long as the pieces forming its web are well connected together edgewise, there is no difficulty in meeting this racking strain. But if a beam were constructed of which the web consisted of strakes or narrow planks placed edge on edge, and having little connection edgewise, then obviously, as the beam bent, these planks would be made to slide upon one another by the racking strains.* And if these strakes were crossed at right angles by ties, corresponding to the ribs or timbers of a wood ship, these ties would add little to the strength of the web against racking. For (to quote the well-known illustration of Sir Robert Seppings), if a field-gate be made of pieces, all lying parallel or at right angles to one another, its resistance to distortion of form will be very small. On the contrary, if the strakes forming the web are crossed by diagonal ties—corresponding to the cross-bar of the gate—there will be a great addition to the strength of the combination against racking and distortion of form.

Such are the simple principles upon which the use of diagonal “riders” or ties in wood ships is principally based. The side planking above the bilge has in itself little strength to resist racking strains; and in many cases these strains have been so severe as to show marked evidence of their action. When the line-of-battle ship *Cæsar* stopped on the launching ways and broke considerably, it was in the planking near the middle of her depth that working was most apparent; the diagonal riders also showed signs of severe straining. Moreover, it is a matter of common observation that, when the caulking of the seams of planking in a wood ship becomes slack and needs renewal, she is much more liable to working in the longitudinal sense. This circumstance is easily explainable, seeing that, when well caulked, there is a much greater resistance to the relative motion of the planks which, racking strains tend to produce. Diagonal riders furnish, however, the best corrective for this source of weakness, if a single thickness of planking is worked.†

* For a well-known illustration of the above statement, the reader may turn to the springs of railway-carriages.

† In some small vessels built by the late Mr. Ditchburn, bolts were driven

edgewise through adjacent strakes of the skin planking, in order to prevent racking. A similar plan of bolting is sometimes adopted in certain portions of the bottom planking of ordinary woodships.

When first introduced into the Royal Navy by Sir Robert Seppings, early in the present century, these riders consisted of massive timbers, worked inside the transverse ribs of the ship. But for many years past iron-plate riders have been substituted for the timber riders, and with very great advantage. In Fig. 102 these riders are indicated in both the cross-section and the inside view, being marked *r, r*. It will be observed that they are worked *inside* the ribs, and inclined 45 degrees to the vertical. Wood-built merchant ships are usually furnished with similar iron riders, which are often worked *outside* the timbers; and that arrangement has some advantages in point of strength, although it is not so convenient to execute during the construction of a ship. Whether fitted inside or outside, the riders are usually inclined so that their upper ends slope towards the midship section of the ship; near the middle of the length (as shown on the inside view (Fig. 102), the two systems of riders belonging to the fore and after bodies respectively are made to cross each other at right angles. In some cases where special strength is desired, this duplicate arrangement of the riders is carried right fore and aft, as in her Majesty's ship *Caledonia*; but the more common plan is to have one system only. It will be observed that, as usually arranged, these iron riders are very efficient aids against hogging strains, which are those most injurious to wood ships. When hogging takes place, the ends must drop relatively to the middle, a change of form which would bring the iron riders under tensile strains, the kind of strains which they are best fitted to resist. Against compressive strains these thin narrow bands of iron cannot be nearly so efficient as against tensile strains, so that, as commonly fitted, riders are not of much service against sagging strains, except amidships, where the two systems overlap one another. Of course it is amidships that the severest strains are experienced, so that the crossing of the riders there is a great advantage; and it has been suggested that, if the duplication of the systems were carried through, say, one-third or one-half of the length amidships, there would be a further gain in strength, owing to the circumstance that the riders would then assist against sagging as well as hogging.

Composite ships of the mercantile marine were usually built with a single thickness of planking, and consequently needed diagonal strengtheners. One common plan of fitting these was to have rider plates riveted outside the iron frames, and inclined 45 degrees to the vertical. The upper ends of those riders were

attached to the sheer strake, and the lower to another detached longitudinal tie, formed by a strake of plating worked at the bilge.

The composite ships of the Royal Navy are built with their outside planking in two thicknesses. The edge-seams of the planks in the inner thickness are each covered by a plank of the outer thickness; the seams of the outer thickness being similarly covered by the planks of the inner thickness. A strong edgewise connection is thus made in the double skin, and consequently diagonal rider plates are dispensed with. It should be added that this plan of working the planking in two layers is principally adopted because these vessels have their bottoms covered with copper sheathing, and any injurious galvanic action of the copper on the iron hull can thus be avoided.

Other composite ships have been constructed with the skin planking in two thicknesses, one or both of which had the planks worked diagonally; it was then unnecessary to fit diagonal rider plates to assist the skin against racking strains.

This diagonal system of planking has also been adopted in some special classes of wood ships with great success. The royal yachts are examples of this system of construction, and Mr. White, of Cowes, has applied it in many vessels built at his yard. Three thicknesses of planking are employed, the two inside being worked diagonally, and the outer one longitudinally. The two diagonal layers are inclined in opposite directions, and the skin thus formed possesses such superior strength to the skin of an ordinary wood ship that there need be comparatively little transverse framing above the bilges. Direct experiments with models, and the experience gained with ships built on this plan, have demonstrated its great superiority in the combination of strength with lightness. The royal yacht *Victoria and Albert*, built on this plan, with her unusually powerful engines and high speed, is subjected to excessively great sagging moments,* but has continued on service for nearly thirty years with complete exemption from signs of weakness. Like many other improved systems of construction, this is found rather more expensive than the common plan; but if wood had not been so largely superseded by iron and steel, probably much more extensive use would have been made of the diagonal system.

* See the facts stated at page 299.

It may be mentioned that the large steam and sailing launches employed in the Royal Navy are built on a somewhat similar plan; the skin planking is in two thicknesses worked diagonally, with the two layers inclined in opposite directions. These boats answer admirably, and have frames only on the flat of the floor, where the wear and tear of grounding have to be borne.

Iron and steel ships have outer skins formed by numerous plates, each of which is strongly fastened at the edges, as well as the butts, to the plates adjacent thereto. Such a combination is very strong against longitudinal racking strains, and needs no supplementary strengthening such as the diagonal riders of wood or composite ships. Many proposals have been made, and several plans have been patented for using diagonal strengthenings in iron ships, the superiority of an iron skin, and its capability of resisting and transmitting strains in all directions, not having been apprehended. From the bilges upwards, the outside plating forms the principal part of the web of the equivalent girder section in ordinary iron ships like that in Fig. 103; and when properly stiffened, it acts this part most efficiently when the ship is upright. When she is considerably inclined, some parts of the same plating contribute strength to the flanges of the girder-section for that position, as already explained. Vessels with double bottoms extending far up the side, or with wing-passage bulkheads like that in Fig. 104, gain much on vessels with single bottoms, since the additional skin contributes to the strength of the web of the girder for the upright position, and to the strength of the flanges of the girders for inclined positions. Any other longitudinal bulkheads which extend over a considerable length in the ship may also be regarded as contributing to the longitudinal strength, and one of the most valuable additions of this kind that can be made to a ship is a middle-line bulkhead like that shown in Figs. 18-25 (page 26) for an ironclad of recent type. The longitudinal bulkheads fitted in the *Great Eastern* add greatly to her longitudinal strength. It need hardly be said, however, that such bulkheads are fitted primarily with a view to increase in safety or accommodation; the increase in structural strength being a secondary consideration.

Mention may also be made, in passing, of a plan upon which a few iron ships have been built, intermediate in character between ships with transverse frames and others with longitudinal frames. The main frames in these special vessels lie diagonally, somewhat after the fashion of riders, and therefore cross the probable line of fracture of the plating in ordinary iron

ships, which line, it has been said, would lie in a transverse plane. It is hoped, thereby, either to divert the line of fracture from this transverse plane to some longer and stronger diagonal line or else to make the diagonal frames add to the strength of the transverse section which gives the smallest effective sectional area to the bottom plating. The plan has not found favour with shipbuilders, nor does it seem comparable to the longitudinal system, either in cheapness and simplicity of construction or the combination of lightness with strength.

Vessels designed for service in shallow waters often have their hulls strengthened longitudinally by girders. It has been shown that the *depth* of any cross-section of a vessel has a great influence upon the amount of its resistance to bending strains; and in these special vessels the depths of the hulls are so small as to render supplementary strengthenings essential. The American river steamers before mentioned furnish good examples. Their hulls are extremely shallow, and have to carry an enormous superstructure of saloons, &c., although they have in themselves little longitudinal strength. To supply this, what is termed a "hog frame" is constructed. It consists of a strong side keelson fitted along the flat floor of the vessel, at some distance out from the keel. Upon this keelson are erected a series of timber pillars, and along over the heads of the pillars a strong continuous timber beam or tie is carried, diagonal struts being fitted between it and the keelson. A light but strong timber girder of considerable depth is thus firmly combined with the shallow hull, and made to help it efficiently against hogging. In other light-draught vessels built for river or coast service, with iron or steel hulls, arrangements have been adopted similar in principle to the foregoing, iron or steel lattice girders having been substituted for the more cumbrous and less efficient hog frame. These vessels, being designed for smooth-water service, are not subjected to longitudinal strains of so severe a character as those experienced by ships at sea, and, what is still more important, their strains remain nearly constant in character as well as intensity. Hence their case is much more easily dealt with in the manner described, than is that of a sea-going ship which has to bear rapid and extreme variations of longitudinal bending strains while she rolls from side to side in a seaway. At the same time, there is considerable range for the exercise of ingenuity in securing the lightness of construction demanded by the shallow draught. The conditions of the problem resemble more closely those of bridge construction than those connected

with the construction of sea-going ships, with which we are more especially concerned.

Figs. 105 and 106 furnish illustrations of this class; being respectively a side view and cross-section of a tug-boat built for the Godavery river from the designs of Mr. J. R. Napier, about fourteen years ago.* The draught of water was not to exceed one foot; it was consequently necessary to make the structure as light as possible, and steel was used instead of iron. The hull proper is that of a shallow open boat, about $3\frac{1}{2}$ feet deep; it is formed, as shown in Fig. 106, of steel plates $\frac{1}{8}$ inch thick, with each strake of plating stiffened by a longitudinal angle-bar. The transverse frames consist of angle-bars, spaced 9 feet apart, and therefore quite subordinated to the longitudinal frames. The hull proper, being so shallow and without a deck, could not contribute the necessary longitudinal strength; but this is obtained in a very ingenious manner. An awning was necessary to furnish protection from a vertical sun and tropical rains; it is marked *a, a* in the diagrams, and is about 10 feet above the bottom. To convert this into an efficient upper flange, it is formed of steel plates $\frac{1}{16}$ inch thick, each strake being stiffened by a longitudinal angle-bar. Transverse angle-bars are fitted, 9 feet apart, vertically over the corresponding transverse frames of the hull, and diagonal braces (*c, c*, Fig. 106) connect the corresponding transverse stiffeners to hull and awning, preventing the latter from being pulled or blown over. Lattice girders (*b, b*, Fig. 106) formed by diagonal and vertical bars, as shown in Fig. 105, are fitted on each side to strengthen the connection between the awning and the hull,

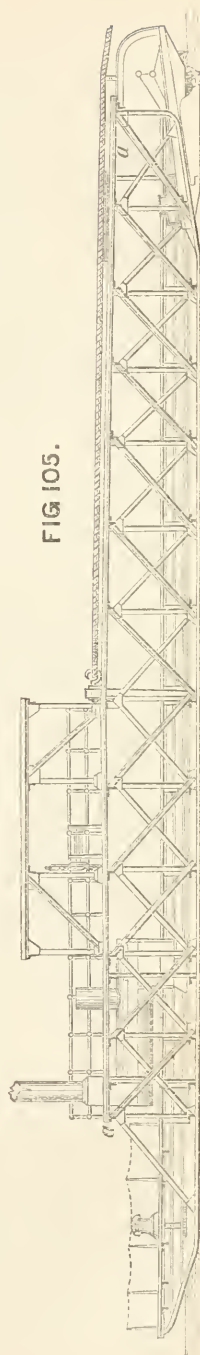

FIG 105.

* The drawings and particulars are taken from vol. viii. of the *Transactions* of the Institution of Naval Architects.

and to enable them to act together in resisting longitudinal bending. The diagrams explain further particulars. The vessels are driven by paddles placed under the sloping stern; the boiler is placed at the bow, where there is also a steam capstan; and the tow-rope is secured near the middle of the length and led along over the awning.

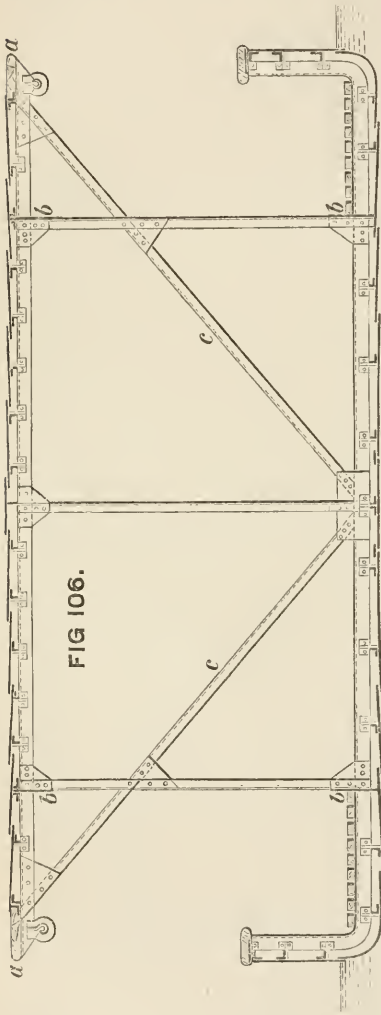

FIG 106.

Before concluding this division of the subject it may be desirable to glance at some of the more important results of calculations made to determine the maximum tensile and compressive strains, experienced by the upper and lower parts of the structures in various classes of ships, when they are subjected to longitudinal bending moments. For these calculations it is commonly assumed that a ship occupies one of the extreme positions of support illustrated by Figs. 87 and 88, and the resulting bending moments are estimated in the manner explained on page 289. Having constructed the equivalent girder for the weakest section nearly amidships, its moment of resistance to bending is calculated; and, having this data, the maximum tensile and compressive strains on the material can be found by means of the formula on page 334. It has been fully explained that this method of procedure is chiefly useful for comparisons between ship and ship; and must not be treated as a determination of the actually severest strains to which a ship may be subjected in a seaway.

Taking first the various types of war-ships mentioned in Chapter VIII., the following statements will form an interesting

supplement to the tables on pages 297 and 299. Armoured frigates of the *Minotaur* type are subjected to unusually severe bending moments, tending to make them hog. From calculations made at the Admiralty, it appears that the maximum tensile strain on the material in the upper deck, estimated in accordance with the assumptions explained above, is only about 5 tons per square inch of sectional area. This is about *one-fourth* of the ultimate strength of good iron plates such as were used in those ships; and this satisfactory result is largely due to the great depth of the ship, the use of strong iron deck-plating, and of a partial double bottom with longitudinal frames. It should be added that in this estimate the armour plating on the sides is treated simply as a burden, contributing no resistance to tensile strains.

The converse case to the *Minotaur* is presented by the central citadel type, which experiences very great sagging strains when astride wave-hollows. In the example of this type given in the table on page 299 the maximum strain on the material, when the ship is astride a wave-hollow, was found by calculation to be $5\frac{1}{2}$ tons per square inch. This vessel was built of mild steel, and the maximum tensile strain on the bottom was, therefore, about *one-fifth* of the ultimate tensile strength of the material. In this calculation also the armour was treated only as a burden: but a further calculation made on the assumption that the armour was effective against compressive strains gave practically the same result, the maximum tensile strain (on the bottom) being 5 tons. The reason for this practical agreement may be given in passing. When the armour was excluded from the calculation, the neutral axis of the equivalent girder was about *seven-tenths* of the total depth above the bottom; whereas with the armour included it rose to *three-fourths* of the depth. Consequently the increased moment of inertia of the girder section with armour included, was nearly counter-balanced by the increased height of the neutral axis above the bottom.

These two extreme cases represent unusually severe strains for armoured war-ships. For example, in the turret-ram (mentioned in table on page 299), the maximum strain on the material was found to be only 2 tons per square inch of sectional area. In the *Devastation* the maximum strain, under a sagging moment, was only $1\frac{1}{2}$ ton per square inch. The corresponding maximum strain for the "belted cruiser," under hogging moment, was $2\frac{1}{2}$ tons per square inch. The central battery ship only sustains a maximum strain of 2 tons to the square inch, as shown in specimen

calculations on page 338. These very moderate strains, it must be remembered, are obtained in vessels which have very lightly-constructed hulls, and in which the scantlings are limited by considerations of local strength and durability. Were the principal longitudinal bending moments exclusively considered much thinner bottom plating might be accepted: but this thinning would be objectionable, because it would reduce too far the local strength and durability of the skin. In short, in these vessels, as in many others, the scantlings are governed by considerations of local strength, and when that is provided there is a large margin of strength to resist principal strains. These remarks do not apply to the plating on decks and other strengtheners used to secure a due proportion between the upper and lower flanges in the equivalent girder. Nor must it be overlooked that frequently in war-ships the thickness of deck-plating provided for protective purposes is far in excess of that required for structural strength. Owing to these various influences the position of the neutral axis varies greatly in relation to the total depth of the equivalent girder in different classes of war-ships; but this variation has no practical importance, and all the strains mentioned above are the maximum strains sustained by the material most distant from the neutral axis.

To the foregoing facts for armoured war-ships one example may be added for an unarmoured ship. In the *Iris*, when floating on the crest of a wave 300 feet long, and 20 feet high, the maximum tensile strain on the material in the upper deck is 5 tons per square inch. The neutral axis for hogging is 52-100ths of the depth, below the top of the girder, so that the maximum compressive strain on the bottom is about 4.6 tons per square inch. This vessel is built of mild steel, having a mean tensile strength of about 28 tons per square inch.

Corresponding calculations for merchant ships have been made by many authorities during the last ten years; and the recorded results are of great interest.* In most of these calculations it has been assumed that the maximum bending moment likely to be experienced, on a wave crest, may be taken as one thirty-fifth of the product of the weight of a ship into her length; but it must be remembered that this value of the bending moment may be exceeded under certain circumstances (see page 298), and that

* See various Papers in the *Transactions* of the Institution of Naval Architects for 1874, 1877, and 1878.

Also Papers in the *Transactions* of the Institution of Engineers and Ship-builders in Scotland for 1878.

in some special classes of ships sagging strains may become most important.

From the published calculations for the strength of merchant steamers it appears that in the smaller classes the scantlings found necessary to give sufficient local strength provided an ample margin of longitudinal strength according to the equivalent girder theory. In the larger classes the margin of longitudinal strength is much less than in the smaller; and, in some cases, the maximum strains on the material, estimated in the manner previously described, are much greater than the corresponding maximum strains in war-ships of equal lengths. Mr. W. John, whose labours in this department have been most valuable and extensive, published the following figures in 1874, for ships then afloat, as illustrations of the increase in maximum strain accompanying increase in dimensions. All these ships were supposed to be about eight beams in length, and eleven depths in length, and their scantlings agreed with the then current practice for first-class vessels.

Register Tonnage of Vessel.	Maximum Tension on the Upper Works.
	Tons per Square Inch.
100	1.67
500	3.95
1000	5.19
1500	5.34
2000	5.9
2500	7.1
3000	8.1

Other examples showed that if the proportions of length to breadth and depth were increased the vessels were subjected to greater strains; and in one vessel over 400 feet long a maximum strain of nearly 9 tons was found. Vessels having less proportions of length to breadth and depth sustained smaller strains.

Later investigations have confirmed the general accuracy of these conclusions, and shown that maximum strains of from 5 to 7 tons per square inch are brought upon well-built ships from 250 to 350 feet in length, and 8 to 10 beams, or 10 to 12 depths in length. The calculations for these maximum strains are based upon the assumptions stated above.

One marked feature in many of these calculations for merchant ships is the comparatively low position of the neutral axis of the equivalent girders. The decks forming the upper flanges of the

girders were so slightly strengthened in relation to the strength of the bottom plating, &c., below the bilges, that the neutral axis was situated only from 30 to 40 per cent. of the depth above the bottom. Hence it followed that the tensile strain on the upper deck produced by hogging moments was frequently about twice as great as the corresponding compressive strain on the bottom. This relative weakness of the decks has been corrected to some extent in recent ships by the use of strongly plated iron or steel upper or main decks. In the very long and large ocean-going steamers now building, great attention is being paid to the strengthening of the principal decks, two or three decks being completely plated.

The magnitude of the strains which calculation has shown to be possible in many ships of extreme length and high ratios of length to depth and breadth, has naturally led to a closer scrutiny of the fundamental assumptions used in the calculation. It is a matter of fact that many iron ships which, according to the equivalent girder method, may be called upon to sustain strains of 6 to 7 tons per square inch, go on for years in active service without displaying any signs of weakness. In fixed land structures of wrought iron, such as girders or bridges, the maximum strain which could be frequently applied would be not more than 4 to 5 tons per square inch; so that the ship has not apparently so great a "factor of safety" as the bridge. Nor is this the only point of contrast between a ship and a girder.

The comparison of a ship to a girder in her resistance to longitudinal bending, is based upon the assumption that the various parts of the structure are so combined and supported as to enable them to act together. Unless care be taken to provide against local strains, failure by buckling, and other causes of damage, the ultimate strength of the various parts of an iron or steel ship cannot be developed, and the comparison to a well-constructed girder does not hold. Moreover in a ship at sea, the simultaneous occurrence of longitudinal bending moments, transverse and local strains still further complicates the problem; for many of the pieces in the structure have to assist in resisting all these strains. In considering what ought to be the upper limit of strain sustained by a ship when treated as a girder and supposed to be instantaneously balanced on the crest or astride the hollow of waves having a length equal to her own, it is, therefore, absolutely necessary to proceed in accordance with experience of ships that have been tested at sea, rather than by analogy from wrought-iron structures, such as bridges. Here

again the calculations made for Lloyd's Register give very valuable information. Mr. John summarises the results as follows: In well-built iron ships, wherein local strains are properly met, the maximum tension on the upper works may reach 6 to 7 tons per square inch without any sign of weakness; when the tension reaches 7 to 8 tons per square inch some signs of weakness are occasionally met with: but when it reaches 8 to 9 tons per square inch, the want of strengthening soon becomes apparent. In cases where local strains or buckling of thin plating have not been provided against, failure may take place even when the vessel, if treated as a girder, is subjected to very small strains.

It may appear strange that a strain of, say 7 tons per square inch, can be accepted for an iron ship under the assumed conditions, whereas, in a fixed bridge, strains of 4 or 5 tons would be considered a safe limit for the working load. The explanation is very simple. The working load is frequently if not continuously brought upon the bridge; whereas the ship seldom comes under the assumed conditions of extreme straining.* Long and large ships especially gain in this respect, seldom encountering waves as long as themselves; and this circumstance should be borne in mind while comparing the maximum tensions shown in the preceding table. Small, short ships may often encounter waves as long as themselves, and although the resulting strains may be very moderate their frequency and rapid alternations are important features. Undoubtedly the smaller ships are relatively less strained than the larger ships, the difference being mainly due to the fact mentioned above that the scantlings of the smaller ships are regulated by the requirements of local strength and durability.

The principles which govern the provision of *transverse strength* admit of being explained much more briefly than do those for longitudinal strength. In nearly all classes, the transverse frames or ribs, the deck-beams, and the planking or plating of the skin and the decks, together with the pillars under the beams, and the beam-knees, &c., connecting the decks with the sides, contribute to the transverse strength. Iron and steel ships have the further advantage of the strength supplied by more or less numerous transverse bulkheads; and so have most composite ships, as well

* In the bridge also there are strains due to its vibration under the action of wind or moving load, and those due to variations of temperature.

as many wood ships of recent types. It will be convenient, therefore, to arrange the discussion of this branch of the subject under the following heads:—(1) The strength of the transverse frames or ribs; (2) the strength of deck planking or plating; as well as of deck-beams, and their connections with the sides; (3) the strength obtained by pillars; (4) the usefulness of bulkheads in relation to transverse strength.

With each transverse frame, or rib, a portion of the skin, both inside and outside, may be considered to act in resisting changes of transverse form. For example, suppose in Fig. 103 (page 346) the ribs to be spaced 2 feet apart. If two imaginary planes of division are drawn cutting the skin midway between the frame chosen and the frames adjacent to it on either side, this strip of skin may be regarded as forming an outer flange of a girder, the web and inner flange of which are formed by the frame. The enlarged section, placed a little below the upper deck in Fig. 103, shows the sectional form of this girder. Similarly each deck-beam may be regarded as associated with a strip of the deck-planking or plating; and, taking the beams with the frames to which they are attached, each of the combinations may be regarded as a *hoop-shaped girder* having in itself considerable strength to resist change of transverse form. Similarly in wood ships each rib and beam may be regarded as associated with the adjacent strips of inner and outer skins. It is unnecessary to say anything further respecting the skins, as considerable attention has already been given to their arrangements in different classes; but it is desirable to note briefly some of the chief differences in the construction of the transverse frames.

The ribs of wood ships are necessarily made up of several lengths (or futtocks) which are either bolted and dowelled (as shown in Fig. 102) or else connected to each other in some other way, which leaves adjacent pieces comparatively free to bend inwards or outwards in relation to one another. As a consequence no single rib can be regarded as having much strength in itself against strains tending to change its form: the butts of the various futtocks are places of comparative weakness which can scarcely be avoided. The shipbuilder, therefore, has recourse to the plan of shift of butts, described on page 330 for planking, as shown in the inside view, Fig. 102; and the effect is to succour the ribs at the butts by the unbroken strength of adjacent ribs. This object is effected satisfactorily; but the framing must be weaker than it would be if the individual ribs could offer considerable resistance to changes of transverse form. Formerly it

was the practice to fit transverse timber riders within the ribs in order to strengthen the latter, but the practice died out when diagonal riders came into use.

The ribs of ordinary iron, steel and composite ships are much stronger individually than those of wood ships. Fig. 103 explains their construction (see especially the enlarged sections), and it will be noted that each frame is really a Z-shaped girder, the flanged section giving it great strength to resist alterations of form. The angle-bars and plates of which the frame is made up are either obtained in one length or else welded or butt-strapped into the necessary lengths: the whole being so combined that there are no places of weakness corresponding to the butts in the ribs of a wood ship. This superiority shows itself markedly during the process of building a ship, the frame of a wood ship usually being built up piece by piece, whereas the frames and beams of iron and steel ships are very frequently put together before being hoisted into place, and sustain no sensible change of form during that operation. Below the bilges floor-plates are fitted, gradually increasing in depth towards the keel: these floors are of great value in resisting transverse bending strains, as well as forming supports for cargo, &c.

Vessels in which the main frames lie longitudinally usually have their transverse frames spaced much more widely than in iron ships of the ordinary construction. In vessels of the mercantile marine built on the system advocated by Mr. Scott Russell, the only transverse frames—excluding the complete bulkheads—are placed from 12 to 20 feet apart, and formed by plates fitted in between the longitudinals, with stiffening angle-irons on the edges of the plates. These plate-frames are termed “partial bulkheads,” resembling the outer rim of a transverse bulkhead of which all the central parts have been cut away. Their principal use is to furnish a series of sections having considerable transverse strength and situated between the complete bulkheads; also to stiffen the longitudinals, and keep them in their proper positions. The *Great Eastern* has no other transverse frames than such partial bulkheads; but the existence of an inner skin adds greatly to the transverse strength, this skin forming strong inner flanges to the hoop-shaped girders, of which the outer bottom forms the outer flanges, and the plate-frames the webs. It should be added that in vessels so constructed the longitudinal frames are commonly made very numerous, in order to stiffen the bottom; but even when these frames are spaced only 3 or 4 feet apart,

the spaces of bottom plating left without direct support have areas of from 40 to 60 square feet, and hence results an amount of flexibility in the bottom which may become objectionable.

To obviate this objection, and give greater support to the bottom, as well as to increase the transverse strength, the ironclad ships of the Royal Navy, built on the bracket-frame system illustrated by Fig. 104, have the transverse frames 4 feet apart. Most of these frames, within the limits of the double bottom, are formed as in the diagram, plate-brackets being fitted to connect the inner and outer angle-irons with each other and with the two skins; as well as to secure the longitudinals to the skins, and prevent any change of angle. This light and simple arrangement gives considerable transverse strength, but it is reinforced at intervals of about 20 feet by partial bulkheads similar to those used by Mr. Russell, and forming watertight partitions in the double-bottom space. Underneath the engine-room, where considerable strength is required to meet the strains due to the motions of the machinery, instead of bracket-frames, it is usual to fit plate-frames filling the spaces between the longitudinals, and to cut lightening-holes in them. Before and abaft the double bottom also, where there is no inner skin to contribute to the transverse strength, similar lightened plate-frames are fitted.

The bracket-frame system of construction was introduced by Sir Edward Reed when Chief Constructor of the Navy, and has been generally adopted in the construction of foreign ironclads. It differs from the system used in the *Warrior* and other early ironclads mainly in the adoption of the complete double bottom and the more complete subordination of the transverse to the longitudinal framing. In the *Warrior*, for example, the transverse frames were more numerous and heavier than in recent ships. Their greatest spacing was about 44 inches; and for a considerable part of the girth intermediate frames were fitted, reducing the spacing to 22 inches. All these were lightened plate-frames, with strong, heavy, continuous transverse frames on the inner edges. Moreover, about 30 or 40 feet of the length at each end of the *Warrior* was framed transversely, the longitudinals being stopped short; and at these parts the transverse frames were as closely spaced as those of ordinary merchant ships. In the *Minotaur* class quite as great prominence was given to the transverse frames, which were spaced 28 inches apart. The changes effected in ships built on the bracket system have enabled considerable savings to be made in the weight and cost

of hull, at the same time that the safety and general structural strength have been increased. Examples of these savings appear in the following chapter.

Allusion has already been made to the close spacing of the transverse frames behind armour in all ironclads; and it is unnecessary to add to these remarks. If there were no armoured side to be supported, a wider spacing of these frames would be adopted; and, in fact, this is the arrangement made in the unarmoured upper works of ships with central batteries, barbettes, or citadels.

Iron and steel merchant ships, built on the cellular system illustrated by Fig. 104*a*, are framed above the bilge much in the same manner as other ships of the same classes; while within the double bottom they resemble the ironclads, but have additional transverse stiffeners as explained on page 353. In most of them, at intervals of 12 feet or thereabouts, deep plate-frames or "partial bulkheads" are fitted, for the same purposes as the corresponding strengthenings in ships built on Mr. Scott Russell's system. To complete these partial bulkheads deep plate beams are fitted across under the decks, and thus stations of great transverse strength are secured at frequent intervals, at which the longitudinals are supported.

The despatch vessels *Iris* and *Mercury*, built of steel in 1875, before the movement in favour of cellular construction began to have much influence in the mercantile marine, present some noteworthy features. The transverse frames above the bilges are formed in the ordinary manner of two angle-bars; but the frame spacing is 4 feet. Below the bilges there is a cellular double bottom with bracket frames of the ironclad type. There are continuous longitudinal bulkheads about 6 feet within the side-plating, rising from the top of the double bottom to the upper deck. At intervals of 12 or 16 feet partial bulkheads are built between these longitudinal bulkheads and the side-plating, and thus a strong cellular construction is formed throughout the depth of the ships. Longitudinal stiffeners and the upper and lower deck plating assist to secure rigidity; and the numerous transverse bulkheads complete the work. The *Iris* has now been in commission for a considerable time, and notwithstanding the lightness of her hull-construction and her great engine power she has shown no symptoms whatever of working or weakness.*

* For full particulars of the construction, see a Paper by the Author in the *Transactions* of the Institution of Naval Architects for 1879.

The swift cruiser class of the Royal Navy have iron hulls sheathed with wood planking, and consequently have no double bottoms. The transverse frames are spaced $3\frac{1}{2}$ feet apart, which is about twice the frame-space of large iron merchant ships; and this is found to answer admirably, notwithstanding the great engine-power, fine forms, and heavy armaments carried on the decks. Below the bilges strong longitudinal frames are introduced to reinforce the transverse framing, and on alternate ribs deep floor-plates are fitted intercostally to the longitudinals. This framing is combined with good bulkhead arrangements, and, apart from the sheathing, the construction presents but little more difficulty than that of ordinary iron merchant ships, and it is much more favourable to the association of strength with lightness.

Deck-beams, planking, plating and pillars also assist in preserving the transverse forms of ships. The first duty of the beams is to support the decks with their loads; this was the purpose for which beams were originally fitted. But the beams have other uses. As the various transverse strains previously described are brought to bear upon the structure, the tendency at one time may be to increase the distance between opposite sides of the ship, and at another instant to decrease it. In other words, the beams have to act as ties and struts alternately between the opposite sides. Similarly, the pillars were first fitted as struts or supports to the beams, to assist in supporting the decks; but as the vessel rolls in a seaway, the strains tending to produce alteration of transverse form sometimes produce an increased thrust upon the pillars, and at others produce a pull or tension, if the pillars are well secured at both the heads and heels. Should the pillars be only capable of acting as struts, and not as ties, one important part of their possible usefulness is lacking, because they are powerless to resist any increase in the heights of the decks above the keel.

The beams of wood ships are ordinarily of wood, of rectangular cross-section, and formed of different pieces, joined together by more or less elaborate scarphs, some of which are illustrated in Figs. 109-112, page 393. The beam-ends very frequently rest upon a shelf-piece (see Fig. 102) which is bolted to the inside of the frame timbers, and are so secured to it (by dowels, &c.) as to be capable of withstanding a considerable force tending to pull the beam away from the side. Above the beam-end another strong longitudinal timber, the "water-way," is securely bolted to the timbers and strongly connected with the beam,

greatly increasing the strength of its connection with the side. In all these ways the beam is made capable of acting as a *tie* between the opposite sides. Its action as a *strut* is secured by very accurately fitting its ends against the inside of the timbers. Thus far the arrangement is satisfactory, but it involves considerable skill and cost in scarphing the pieces that form the beam, and connecting the beam with the water-way, shelf-piece, &c. It will be noted, however, that the rectangular form of cross-section is necessarily inferior to the flanged form; and this is an unavoidable defect with wood beams. These considerations have led to the extensive use of iron beams in recent wood ships; similar care being taken to make good the connection of the ends of these beams with the side, in order that they may act as struts or ties. Wood pillars also have fallen greatly into disuse even in wood ships, iron pillars of less weight being readily made more efficient as ties and no less efficient as struts under the beams.

Iron and steel ships have iron or steel beams, which can be readily obtained of various sectional forms, all of which have more or less of that flanged form which has been shown to be so helpful to the association of strength with lightness (see Fig. 116). Like the frames, these beams can be easily welded or strapped, into what is practically one piece, capable of resisting both tension and compression. Moreover, their ends are very simply and strongly secured to the frames (see Figs. 103 and 104), the stringer plates on the beam-ends greatly strengthening the connection of the beams with the side. Iron tubular or flanged pillars can be associated with the beams, and made to resist either tension or compression. In every way, as regards strength and simplicity, the iron or steel ship has the advantage of the wood one in the character and connections of the beams and pillars. The composite ship in these particulars resembles the iron ship.

It has been explained above that deck-flats, whether formed by wood planking or iron or steel plating, assist the deck-beams greatly in the maintenance of transverse form. A completely plated deck, for example, if well stiffened by strong beams and bulkheads, is practically rigid when subjected to strains tending to alter the transverse form. If a ship has a series of such decks, the transverse frames or ribs really have little more to do than to stiffen the sides between the strong decks, or between the lowest of these decks and the bilges. In merchant ships of large size two or three completely plated decks are now common, and they

are of the greatest value in the maintenance of the transverse form as well as in resisting longitudinal bending. This two-fold usefulness has been previously mentioned, and it is as applicable to the skins as to the decks of ships. In armoured ships strongly plated "protective" decks are now the rule; and these decks contribute greatly to the transverse strength, being assisted by other plated decks which are built for structural purposes only. Protective decks are also becoming common in war-ships which have no side armour, and although fitted primarily for protection to machinery, magazines, &c., they are valuable additions to the transverse strength.

The lower decks of ships are often extended over only a portion of the length, or else considerably weakened by having large openings cut in them. Merchant ships, for example, frequently have no lower decks in wake of the cargo holds, and consequently there is not nearly the same strength of connection between opposite sides at those parts as would be secured by a strong deck with its beams. To compensate in part for this loss of strength, it is usual to fit a few strong beams—known as hold-beams—in the cargo spaces; the convenience of stowage is thus little affected, while the strong beams form good ties and struts. In very many cases where such precautions have not been taken, serious working and change in transverse form have resulted. Instead of hold beams, deep plate frames or partial bulkheads are often fitted as previously explained.

Perhaps the greatest point of difference between the action of the beams in wood and iron ships is to be found in their comparative resistances to *change of the angles* between the decks and the sides of the ship. The strains tending to produce such changes have been previously described; and their effects on wood ships have been so serious as to cause shipbuilders to bestow great attention upon beam-knees and their connections. A vast number of plans for beam-knees have been proposed. Formerly, before iron strengthenings became general, cumbrous timber knees were fitted; and in countries where timber is abundant such knees are even yet employed. Forged iron knees are, however, now much more generally employed, and are more efficient than timber knees, as well as less bulky. But even with the best of these arrangements—such as the knees shown under each beam-end in Fig. 102—heavy rolling in a seaway may produce sensible changes of angle. The usual indications of these changes are loosening of the fastenings which secure the iron knee to the side and to the beam-end; and in the larger

classes of wood frigates and line-of-battle ships in the Royal Navy these indications were not at all uncommon, notwithstanding the precautions taken in fitting and bolting the knees.

The reasons for the superior resistance of iron and steel ships to any corresponding change will be obvious on comparing Fig. 102 with Figs. 103 and 104. The beam-ends of the iron and steel ships are shaped into strong knees, far more capable, from their form, of preventing change of angle. These stronger knees are fitted against the sides of the frames, and strongly riveted to them: the frames themselves are riveted to the skin, and in very many cases the stringer plates on the beam-ends are also directly connected with the skin, so that the beam-end cannot change its position relatively to the side of the ship without shearing off numerous rivets, or fracturing plates and angle-bars. Hence it is obvious that, with properly proportioned knees and riveting, change in the angle made by the decks of iron and steel ships with the sides may be almost entirely prevented. Imperfect fastenings in the beam-knees may permit, and in some cases have permitted, working at the junction of the decks and sides even in these ships; especially when they have happened to be associated with a considerable amount of flexibility in the frames to which the beams are attached. But these cases can only be regarded as examples of a defective application of principles which, when properly applied, lead to satisfactory results.

Similar knees are formed on iron beams fitted to wood ships, but then instead of attaching the beam-arm directly to an iron frame, as can be done either in an iron or composite ship, it has to be secured to the side by means of angle-irons riveted through the beam, and bolted to the side planking and timbers. This plan is more efficient in preventing change of angle than the ordinary knees fitted to wood beams, but not so efficient as that of iron and composite ships, the connection with the side not being so perfect.

Sometimes deep plate-knees are fitted below a few of the beams in iron ships, reaching from one deck to that next below it, for the purpose of stiffening the side. The beams forming the boundaries of large cargo-hatches or boiler-hatches in merchant ships are often treated in this manner, and made deeper and stronger than the other beams, for the purpose of compensating for the loss of transverse strength produced by cutting off the beams to form the openings in the deck. The growing use of partial bulkheads in the holds of merchant ships has been mentioned above: at the stations where they occur deeper beams are fitted, as shown (by

dotted lines) in Fig. 104a. In the iron and steel-built ships of the Navy also, it is common to fit "partial bulkheads" at intervals between the main and upper decks, in order to stiffen the sides and to assist the beam-knees in preventing change of angle. Each of these partial bulkheads is very simply formed by a plate 3 or 4 feet wide, connected at its upper end to the beams or stringer plate of the upper deck, at its lower end to the stringer plate on the main deck, and also attached to the side plating. They are commonly fitted above the deck at which the main transverse bulkheads terminate; below this deck the main bulkheads give great assistance to the structure, and lessen the strains brought upon the beam-arms.

Not unfrequently it is a convenience to be able to dispense with knees to lower deck beams; a case in point is illustrated by Fig. 26, page 30. If the ship has a sufficient number of transverse bulkheads, this disuse of beam-knees is no source of weakness. Moreover, it will be remembered that the transverse racking strains described in a previous chapter are likely to be more severe on the upper and main decks than on the lower decks. These racking strains chiefly cause the alterations of angle between the decks and sides, as well as deformations at or near the bilges; but it is especially at the upper parts of the structures of ships that their effects require to be provided against by strong beam-knees and partial bulkheads.

Transverse bulkheads, when properly constructed, add greatly to the transverse strength of all ships, but are most valuable in iron or steel ships having the main frames placed longitudinally and the transverse frames widely spaced. The cross-sections at which such bulkheads are placed may be regarded as practically unchangeable in form, under the action of the severest transverse strains experienced by a ship, provided the thin plating which forms the partition be stiffened by angle-bars, T-bars, or Z-bars riveted to its surface. The most perfect arrangement of the stiffeners is that which places one set vertical and the other horizontal, the plating being thus prevented from buckling in any direction. The decks which meet the bulkheads lend very material help by stiffening them and thereby preventing change of form. Having thus secured great local transverse strength, it becomes necessary to provide the means of distributing it over the spaces lying between any two bulkheads; this end is best accomplished by means of strong longitudinal frames, which are carried from bulkhead to bulkhead, and rest upon them just as the girders of a bridge rest upon the piers. It thus appears

that the efficiency of the transverse bulkheads as stiffeners to the structure depends upon their strength and numbers, the distance between consecutive bulkheads, and the capability of the longitudinal framing to distribute the strength of the bulkheads. Ordinary iron or steel ships, having comparatively few bulkheads, do not gain so much from their help as ships with bulkheads spaced more closely. The desire to have large cargo-spaces in the hold, free from break or interruption, overrides, in most cases, considerations both of increased safety and greater strength. A compromise is sometimes made by fitting, at intervals between complete transverse bulkheads, "partial" bulkheads, formed by deep plate-frames with angle-bars on both inner and outer edges, very similar to those fitted in vessels built on the longitudinal system. But there are considerable spaces in the length of ordinary merchant ships for which the transverse frames have to furnish the principal part of the transverse strength, and the fewness of the bulkheads is one reason for retaining the close spacing of these frames.

When a large number of transverse bulkheads are fitted in an iron or steel ship, the distribution of their strength over the bottom mainly depends upon the longitudinal stiffeners—keelsons, hold stringers, &c. These include very various arrangements, of very various degrees of efficiency; but in none is the distribution so simply and efficiently made as in vessels where the main frames are longitudinal (as in Fig. 104). Longitudinal bulkheads, when they are fitted either at the middle line or towards the sides (or wings), largely assist in the distribution of the strength of transverse bulkheads. In short, all the pieces lying longitudinally, which are efficient against longitudinal bending strains as well as against some local strains, are also valuable distributors of transverse strength.

Composite ships are often fitted with transverse iron bulkheads, the vessels of that class belonging to the Royal Navy being exceptionally well subdivided. These bulkheads contribute much transverse strength, which is distributed very similarly to that for ordinary iron ships, except that the longitudinal pieces are not so well connected to the skin. Closely spaced transverse frames are trusted, however, to supply the chief part of the transverse strength.

Wood ships of recent types in the Royal Navy, and in some foreign navies, have been furnished with transverse iron bulkheads, and the results have been very satisfactory; but there must be greater difficulty in making the bulkheads succour parts lying

between them in wood ships than there is in iron ships; and the attachment of the bulkheads to the sides is not so efficient as it is in either iron or composite ships.

The foregoing sketch of the arrangements made to secure longitudinal and transverse strength in different classes of ships has necessarily been hasty and imperfect. It may, however, serve as a guide to the reader whose interest in the subject leads him to study it more in detail in works devoted to practical shipbuilding. Keeping in mind the principles of structural strength that have been illustrated, and the character of the strains to be resisted, it will be possible to examine intelligently the system of construction adopted in any ship; otherwise such an examination would be impossible.

CHAPTER X.

MATERIALS FOR SHIPBUILDING: WOOD, IRON, AND STEEL.

WOOD, iron, and steel are the three classes of materials from which the shipbuilder of the present day can select. Wood ships have been in use from time immemorial; iron ships for sea-going purposes have not yet completed the first half-century of their construction; steel ships are of a still more recent date. Already wood ships are superseded to a very large extent by iron, and it is probable that before another half-century has passed iron will have given place to steel. Hitherto the use of steel has not become general, for reasons which will be stated hereafter; but quite recently both in France and in this country considerable progress has been made in the manufacture of mild steel well adapted for shipbuilding, and it has been extensively employed both in the Royal Navy and the mercantile marine.

In contrasting the merits of these materials, it will be convenient first to compare wood with iron; afterwards briefly comparing iron with steel. Before proceeding to this discussion, it may, however, be interesting to give a few facts illustrating the wonderful development of iron shipbuilding during the last thirty-seven years.

In 1850, out of 133,700 tons of shipping added to the British mercantile marine, only 12,800 tons, less than *one-tenth*, were iron ships; in 1860, out of 212,000 tons added, 64,700 tons, nearly *one-third*, were iron ships; in 1868, out of 369,000 tons added, no less than 208,000 tons were iron ships. In 1880, out of 404,000 tons of newly-built British ships, 384,000 tons, more than *nine-tenths*, were iron ships.

If attention be limited to steamships, the results are still more striking, wood having kept its place much better in sailing ships, although even there it is yielding rapidly to iron. In 1850, out of 275,000 tons of British mercantile steamers on

the Register, *four-fifths* (218,000 tons) were of wood. In 1860 the total had increased to 686,000 tons; and nearly *five-sixths* (536,000 tons) were of iron. In 1868 the grand total on the Register had nearly doubled again, being 1,341,000 tons; out of this total, wood ships only represented 122,000 tons, steel ships about 8800 tons, and the remainder (1,210,000 tons) were iron-built. During 1880 a tonnage of 346,000 was added to British steam-shipping, and more than 344,000 tons were iron or steel built.

The Royal Navy presents a similar picture. In 1850 the tonnage (B.O.M.) of wood ships had a total of 99,000 tons, against 19,500 tons for iron ships. In 1860 the proportion of wood to iron was even greater than at the earlier date, 420,000 tons, against 34,800 tons. But with the construction of armoured ships iron hulls became general; and in 1870 the total tonnage of wood ships had fallen to 386,000 tons, while that of iron ships had nearly quadrupled since 1860, becoming 130,200 tons. At the present time (1882) nearly all our effective ironclads, including all the ships added to the Navy during the last fifteen years, have iron or steel hulls; and it is a significant fact that not a single wood fighting ship is now being constructed for the Navy, nor has one been laid down for nine years.

Iron shipbuilding originated in this country; has here received its most important developments; and has been the source of very great national advantage. It has rendered us practically independent of foreign supplies of shipbuilding materials; which were becoming more and more important in the later days of the supremacy of wood shipbuilding, when the supplies of home-grown timber were quite inadequate to home requirements. Such supplies from abroad were liable to interruption in time of war; and during peace they placed English builders at a great disadvantage, as compared with builders in countries where shipbuilding timbers were abundant and cheap. The United States, Canada, France, and Italy, all furnished ample supplies of suitable timber; and the shipbuilding trade—so peculiarly British—seemed about to pass away into other hands, when the use of iron instead of wood once more restored the balance, and enabled us to regain our former national position.

But more than this: the use of iron ships has been the source of world-wide advantage. Had wood remained in use, ocean steam navigation could never have attained its present wonderful development, and international communication must have remained less regular and frequent. Without iron hulls, the ironclad re-

construction could never have been carried to its present position ; nor could the swift cruisers have been built. Moreover, iron shipbuilding has done very much to encourage progress in the manufacture of wrought iron for all structural purposes, and thus has indirectly benefited other departments of work. In short, the experience of forty years fully confirms the wisdom of the change from wood to iron, and proves that, although iron has some drawbacks, it possesses a considerable balance of advantage. Other nations, endowed with a wealth of shipbuilding timber, have not failed to realise this: in France, Italy, and still more noteworthy in the United States, iron is rapidly gaining ground, and English models are being imitated or improved upon.

A better appreciation of the great increase in the sizes and proportions of ships which has accompanied the use of iron hulls in both the Royal Navy and the mercantile marine will be obtained from a few typical examples. Taking the Royal Navy first, the following tabular statement will suffice:—

Class of Ship.	Date of Construction.	Name.	Displacement.	Indicated Horse-power.	Length.	Breadth.
<i>Wood, unarmoured.</i>						
Largest sailing three-deckers	1815	<i>St. Vincent</i> .	Tons. 4,700	—	Feet. 205	Feet. 53½
„ screw	1859	<i>Victoria</i> . .	6,950	4,190	260	60
„ „ two-deckers .	1860	<i>Duncan</i> . . .	5,700	2,820	252	58
„ „ frigates . . .	1857	<i>Orlando</i> . . .	5,600	4,000	300	52
<i>Wood, armoured.</i>						
Largest class	1863	<i>Lord Warden</i>	7,840	6,700	280	59
<i>Iron, unarmoured.</i>						
Swift cruising frigate . . .	1866	<i>Inconstant</i> .	5,780	7,360	337	50½
<i>Iron, armoured.</i>						
Early broadside ships . . .	1859	<i>Warrior</i> . . .	9,100	5,470	380	58
	1861	<i>Minotaur</i> . .	10,600	6,700	400	59½
	1865	<i>Hercules</i> . . .	8,700	8,530	325	59
Modern „ „	1873	<i>Alexandra</i> . .	9,500	8,600	325	63½
	1869	<i>Devastation</i> .	9,290	6,650	285	62½
Mastless type (sea-going) .	1871	<i>Dreadnought</i>	10,890	8,000	320	63½
	1874	<i>Inflexible</i> . .	11,900	8,000	320	75

This increase in size has not merely been associated with the special strains due to the use of armour, but with the adoption of proportionately more powerful engines, and the attainment of higher speeds. The best of the screw line-of-battle ships of the old type attained from 12 to 13 knots at full speed ; this latter speed was also the maximum of the finest wood frigates. But now the armoured battle-ship has a speed of 14 to 16 knots ; and the swift cruiser class have speeds of from 15 to 18 knots. Wood hulls could scarcely be expected to meet satisfactorily these greatly changed conditions ; but iron hulls have answered the

purpose, and there is no reason to think that the limits of the capabilities of the material have been reached, even in the largest and swiftest ships afloat. Great engine-power in wood-built ships is very trying and injurious to the structures; but no similar wear and tear occurs with iron. The *Orlando* and her sister frigate, the *Mersey*, were, when constructed, experiments in the direction of applying large engine-power and great proportions of length to breadth in wood ships; but the results were anything but satisfactory. These vessels required considerable repairs during their brief period of service, and rapidly fell out of use. Against this failure to sustain successfully the strains incidental to screw propulsion, set the case of the iron-built *Inconstant*, which is longer than the *Orlando*, of less beam, three knots faster, with 80 per cent. greater engine-power, and yet, thanks to her iron hull, displays no signs of working or weakness.

In the United States the attempt was made to build swift cruisers, the famous *Wampanoag* class, of wood. Without entering into any details of the controversy respecting this class, it may be stated that, on all hands, it is now admitted that the wood hulls were not well suited for the great engine-power put into the ships. The fact that several of the class have been left unfinished or unemployed after trial shows the estimation in which the vessels are held by the authorities of the American Navy. Further, it is interesting to note that American shipbuilders are, at length, devoting themselves energetically to the development of iron ship construction. Several small iron vessels have been recently added to their navy; and iron has been used for the hulls of many large fast steamships for ocean navigation. French designers have also acknowledged the superiority of iron to wood, by building their swift cruisers on the model of the *Inconstant*, and their ironclads on the bracket-frame system illustrated in Fig. 104.

In the mercantile marine, as remarkable changes have been made in the sizes and proportions of ocean steamers. Take, for example, vessels on the Transatlantic service. About fifty years ago, the wood-built *Great Western* was considered a remarkably fine vessel; her dimensions were, length 210 feet, breadth $35\frac{1}{2}$ feet, tonnage (B.O.M.) 1340 tons, load displacement 2300 tons. She was followed, in 1840, by the *Great Britain*, built of iron, of which the dimensions were, length 290 feet, breadth 51 feet, tonnage 3270 tons (register), original load displacement 3000 tons. These dimensions were then considered extravagant, if not unsafe; but the ship was not long ago at work,

on the Australian line, although thirty-five years old. The changes made since her construction are still more remarkable. The largest Transatlantic steamers now at work are 500 to 550 feet long by 50 to 52 feet beam, their displacement, when fully laden, being from 13,000 to 14,000 tons. No one can for a moment suppose that such sizes and proportions could have been achieved with wood as the material, in conjunction with very powerful engines and extremely high speeds. Finally, as a crowning example of what may be done with iron, take the *Great Eastern*, 680 feet long, 83 feet broad, of 22,500 tons (register), and load displacement 27,400 tons, which after some twenty years afloat still (1882) remains strong and efficient, having meanwhile performed most arduous work in laying various submarine telegraph cables.

Iron ships are proved to be superior to wood in the following important particulars:—(1) Lightness combined with strength; (2) durability, when properly treated; (3) ease and cheapness of construction and repair; (4) safety, when properly constructed and subdivided. On the other hand, iron ships are inferior to wood in—(1) easy penetrability of the bottom by rocks or other hard pointed substances; (2) fouling of the bottom, and consequent loss of speed, after being afloat for some time. Compass correction in iron ships is now so satisfactorily performed that there is no need to refer to a matter which at the outset had great practical importance. Taking these points in the order in which they have been named, each of them will be illustrated briefly; and after concluding these remarks, a few will be added on the subject of the use of iron hulls in unarmoured ships of war.

First, as to lightness combined with strength. In wood-built ships of the Royal Navy it is found that about *one-half* the total weight is required for the hull; in similar ships of the mercantile marine the hulls are somewhat lighter in proportion to the displacement. In ordinary iron merchant ships the hull frequently weighs only *one-third* of the total weight, high authorities agreeing that the change from wood to iron effects a saving of from 30 to 40 per cent. on the weight of the hull. The hulls of iron ships of the Royal Navy are not, as a rule, so light as those of iron merchant ships, the difference being due to differences of form and proportions and the more elaborate fittings needed for the special requirements of their service. In some of the earlier iron vessels of the Navy, both armoured and unarmoured, the hulls were as heavy as, or even heavier than, the hulls of wood ships, in proportion to the displacements. But as the principles of iron ship construction have become better understood, considerable savings

in weight of hull have been effected simultaneously with an increase in structural strength, and now it is not uncommon to find the weight of hull only 30 to 40 per cent. of the total displacement, in vessels carrying the thickest armour and heaviest guns. This expression of the weight of hull as a fraction of the displacement, or total weight, of the ship is by no means a complete view of the comparison of wood and iron ships. It takes no cognisance of the fact, to be hereafter illustrated, that forms, sizes, and proportions are now commonly adopted that could never have been used with wood as the material; and it does not recognise the variations which, for similar methods of construction, have to be made in the ratio of the weight of hull to the displacement, in order to secure equal structural strength in vessels of different sizes. It is, however, a sufficiently accurate mode of comparison for our present purpose, and is very commonly used. The following tabular statement will show at a glance the advantages in point of lightness possessed by iron ships of various classes; most of the figures are taken from actual ships, and may therefore be accepted without question:—

Classes of Ships.	Percentage of Displacement.	
	Weight of Hull	Weight Carried.
Wood merchant ships	35 to 45	55 to 65
„ war-ships, unarmoured	50	50
„ „ „ ironclad	48 to 50	50 to 52
Iron merchant ships	30 to 35	65 to 70
„ passenger steamers	40 to 45	55 to 60
„ troopships, Royal Navy, early types	50 to 52	48 to 50
„ „ „ „ later types	48 to 50	50 to 52
„ war-ships, unarmoured (swift cruisers)	50	50
„ „ „ ironclad, early types	52 to 58	42 to 48
„ „ „ „ later types	40 to 45	55 to 60
„ „ „ „ mastless type	30 to 35	65 to 70
„ „ „ „ circular type (Russian).	20 to 22	78 to 80

Notes to Table.

The *Orontes* and *Tumar* are the representatives of the earlier troopships. The Indian troopships represent the later types, and possess a double bottom, which their predecessors did not possess, being safer as well as lighter.

In the weight of hull for the swift-cruiser class there is included a considerable weight of wood sheathing, fixed outside the iron hull in order that the bottoms might be coppered or zincked. This wood is unnecessary for structural strength; excluding it, the percentage for hull would sink to about 42 per cent. of the

displacement, notwithstanding the great engine-power and high speed of the ships.

The case of the ironclads is so important that the following additional illustrations may be interesting.

Ironclads of Royal Navy.		Weight of Hull.	Weight carried.
Early types	{ <i>Black Prince</i>	Tons. 4970	Tons. 4280
	{ <i>Defence</i>	3500	2500
Recent types	{ <i>Bellerophon</i>	3650	3800
	{ <i>Monarch</i>	3670	4630
	{ <i>Invincible</i>	2740	3200
	{ <i>Devastation</i> (mastless)	2880	6410
	{ <i>Temeraire</i> (zinc sheathed)	3600	4940
	{ <i>Alexandra</i>	3800	5700
	{ <i>Inflexible</i>	4350	7550

The explanation given in Chapter IX. of the structural changes by which these remarkable results have been accomplished need not be repeated. Perhaps the saving in weight will be better appreciated when it is stated in another form. In a large ironclad of 8000 to 9000 tons displacement the decrease in weight of hull would amount to quite 800 or 1000 tons, and this being transferred to the carrying power constitutes a most notable addition thereto. At the same time a stronger, safer ship is obtained. The moderate freeboard of the mastless type conduces to their greater lightness of hull.

Iron ships are, then, undoubtedly superior to wood ships in their combination of lightness with strength; and the chief causes contributing to the difference may be briefly summarised.

Each piece in the structure of a ship may be regarded in a twofold aspect: first, as an individual piece liable to be subjected to tensile, compressive, bending, or torsional strains; secondly, as a piece combined with and fastened to adjacent pieces in order that it may assist the general structural strength. Following the method of the preceding chapters, this may be expressed by saying that the various pieces making up the structure must be arranged with reference to both the local and the general requirements. Moreover, the foregoing discussion will have shown that tensile and compressive strains are of the first importance: bending strains have to be borne by some pieces, such as the deck-beams, the ribs, and longitudinals, but these strains are less important; while torsional or twisting strains are of rare occurrence, and scarcely require consideration.

Let the resistances of *single pieces* of wood and iron to tensile or compressive strains be first considered. Take a simple tie-bar

for example, and suppose a certain weight suspended to one end while the upper end is fixed. As the weight is gradually increased, the bar will begin to stretch: for a certain increment of weight the elongations will be directly proportional to the suspended weight, and when the latter is removed, the bar will return to its original length: the limits within which this condition holds are termed the "limits of elasticity," or sometimes the "elastic limits." As the suspended weights are still further increased, and the limits of elasticity are passed, if the weights are removed, the bar will be found not to return to its original length, but to have a permanent elongation or "set." Finally, as the weights are yet further increased, they will become sufficient to break the bar; and this determines the *ultimate strength* of the bar. As a measure of precaution, the strain brought upon this tie-bar, and likely to be frequently repeated, ought not to exceed the limits of elasticity; otherwise the permanent set might, in the end, become dangerously increased. And as a matter of fact, in structures exposed to severe tensile strains, the maximum strain likely to be brought frequently upon any piece is rarely allowed to exceed more than *one-half* or *one-third* the strain which would just bring the piece to its limit of elasticity. Within those limits, as was said, the strains produce elongations proportioned to their magnitude. Let the bar, for example, be L feet long, and let it be observed to stretch $\frac{1}{n}$ th part of its length, under a strain of P lbs. per square inch of the sectional area of the bar: then for any other strain Q we must have

$$\text{Elongation} = \frac{Q}{P} \times \frac{L}{n}.$$

If it were possible without passing the limits of elasticity to *double* the length of the bar, and E were the strain which would produce this elongation, we must have

$$L = \frac{E}{P} \times \frac{L}{n}; \text{ whence } E = Pn.$$

This is confessedly a hypothetical case, since no bar could be stretched to double its length, and return to the original length when the strain was removed; but the hypothesis can be advantageously used in practice. The quantity E is termed the *modulus of elasticity*, and its comparison for various substances furnishes a ready means of estimating the relative efficiencies

of the different materials in resisting change of form.* This is equally applicable to compression, within certain limits, as it is to tension.

In a ship or any other structure it is desirable that no permanent set shall take place in any piece; in other words, that no piece shall be strained beyond its elastic limits. In different materials the *elastic* strength, as it may be termed, bears various ratios to the *ultimate* strength. In wrought iron or steel, for example, the limits of elasticity are not passed until a strain is reached equal to about one-half to two-thirds the breaking strain. In timber, on the contrary, the elastic strength appears not to exceed one-third or one-fourth the ultimate strength; but the limits of elasticity have not been accurately determined. For absolute resistance to fracture, the shipbuilder has to consider the ultimate strengths of the materials employed; for ordinary conditions of service he has to consider what shall be the *working* strains which can be repeatedly brought upon the various parts without producing permanent change of form. The ratios which these working strains bear to the ultimate strengths are termed "factors of safety." These explanatory remarks will enable us to compare with more precision the relative efficiencies of wood and iron.

Take, first, the ultimate resistances to *tensile* strains of these two materials. Good iron plates, such as are used in the hulls of her Majesty's ships, have a tensile strength of from 40,000 to 50,000 lbs. (18 to 22 tons) per square inch of sectional area, the weight per cubic foot being 480 lbs. By means of careful tests this strength is secured in all the iron used; and it is a noteworthy fact that iron can be procured of almost *constant* quality and strength. Taking this as the standard, let us see how the timbers chiefly used in shipbuilding compare with iron as to their tensile strengths in proportion to their weights. One feature in which all timbers differ from iron is in their want of uniformity of quality and tensile strength. Even when the utmost care has been taken to season timbers, considerable variations are found to exist, not merely in different logs, but in the strengths of different pieces cut from various parts of the same tree. Such causes as the existence of knots, cross-grain, &c.,

* To illustrate the use of this formula, we will take an actual experiment. A piece of English oak was found to stretch $\frac{1}{1152}$ of its length

under a strain of 1680 lbs. per square inch. Hence $E = 1152 \times 1680 = 1,935,000$ (nearly), the required modulus.

affect the strength; and it is very different lengthwise of the grain from what it is across the grain. Hence arises a difficulty in ascertaining the *average* strengths of timber materials, and one which is not easily surmountable; with the greatest care in the conduct of experiments, different investigators have reached very diverse results. Taking the best of these experiments, the following are the results for a few of the timbers most commonly used:—*

Timbers.	Average Weight per Cubic Foot.	Tensile Strength.
	Pounds.	Pounds per Square Inch.
British oak	54	7,600 to 10,000
Dantzic oak	52	4,200 to 12,800 ¹
Dantzic fir	36	2,240 to 4,480
English elm	35	5,500 to 13,500 ¹
Pitch pine	40	4,600 to 7,800
Teak	48	3,300 to 15,000 ¹
African oak	62	4,800 to 10,900
Sabicu	57	4,300 to 6,900

¹ Doubtful values; Mr. Laslett gives 5700 lbs. as the upper limit for teak, 7400 lbs. for Dantzic oak, and 6700 lbs. for elm.

British oak may fairly be taken as the standard timber, and its weight per cubic foot is about *one-ninth* that of iron, while its ultimate tensile strength might be about *one-fifth* that of iron. Here, then, the timber apparently gains upon the iron in its ultimate strength compared with its weight; but it is easy to see that it does not really compare so favourably. First, the builder would have no certainty that any piece of oak he might select would reach the average of strength: it might fall so low as to be only one-eighth the ultimate strength of iron, some specimens tested having had that ultimate tensile strength. Second, to guard against possible defects not discoverable on the surface, and to meet the different range of elasticity, a larger factor of safety would be employed with the timber than with iron—about 10 for timber, as against 4 or 5 for iron.

As a simple illustration, take the case of a tie-bar of oak, say

* These figures are based upon the experiments of Barlow, Tredgold, Hodgkinson, and others, of which an excellent summary is contained in the late Professor Rankine's works, as well as upon the more recent and valuable

experiments recorded in *Timber and Timber Trees*, by Mr. Laslett, late Admiralty Inspector of Timber. Sir W. Fairbairn's tables have also been examined in comparison with the others.

1 square foot in sectional area; it would probably have an ultimate tensile strength of about 570 tons, but would only be trusted with a moving load of about 55 to 60 tons. An iron bar of equal weight would have a sectional area of $\frac{1}{9}$ square foot, and a tensile strength of 320 tons; but, owing to its superior elasticity and the confidence felt in its uniformity of strength, it would be trusted with a load of from 65 to 80 tons. Or, to state the comparison somewhat differently, an iron bar capable of safely sustaining the same load as the oak bar need only have an ultimate tensile strength of, say, 260 tons, which would be equivalent to a sectional area of 13 square inches. The oak bar would weigh 54 lbs. per foot of length; the equivalent bar of iron would weigh about 45 lbs. per foot of length.

The same considerations apply to other timbers, oak being superior to most, if not to all of them: and in these considerations we find one of the explanations of the superiority of iron to wood in the combination of lightness with strength. Professor Rankine proposed $5\frac{2}{3}$ tons per square inch as the average ultimate tensile strength of shipbuilding timber; but, in view of the more recent and extensive experiments which have been quoted, this estimate appears too high, and 3 tons per square inch would be sufficient allowance; 48 lbs. per cubic foot is about the average weight of these timbers.

Their ultimate resistances to compression also require consideration, in comparison with the resistance of wrought iron to direct compression.* Here authorities differ widely as to the strength of wrought iron. Professor Rankine gives from 27,000 to 36,000 lbs. per square inch; whereas Sir W. Fairbairn fixed it at 70,000 lbs., on the authority of Rondelet, the tensile strength being 45,000 to 50,000 lbs. per square inch. If the mean of the two statements is taken, it will be found that the ultimate resistance of iron to compressive strains is very nearly the same as its resistance to tensile strains, and this is probably very near the truth.

A fair average value of the compressive strengths of timbers used in shipbuilding appears to be about $3\frac{1}{2}$ tons per square inch, which nearly agrees with Professor Rankine's estimate. Against these strains, moreover, the use of so large a factor of safety as against tensile strains scarcely appears necessary. Supposing a factor of safety of 8 to be taken instead of 10, the safe

* The iron is not supposed to fail by "buckling." See remarks on this subject at p. 396.

working load, on an average, for timber subject to compressive strains would be about *three-eighths* of a ton per square inch: for wrought iron the working load would be from $2\frac{1}{2}$ to 4 tons—say, 3 tons as a safe average. As regards compressive strains therefore timber in single pieces compares better with iron, in strength relatively to weight, than it does in resistance to tensile strains. All pieces in a ship, however, are liable to both classes of strains, and consequently wood is inferior to iron, its inferiority becoming more marked when one passes from single pieces to a combination.

Taking the same timbers as in the list previously given, it appears from experiment that their ultimate resistances to compression are as follows:—

Timbers.	Compressive Strength.
	Pounds per Square Inch.
British oak	7,600 to 10,000
Dantzic oak	6,800 to 8,700
Dantzic fir	7,000 to 9,500
English elm	5,800 to 10,000
Pitch pine	6,500 to 9,800
Teak	6,300 to 12,000
African oak	10,000 to 11,000
Sabieu	6,500 to 9,000

These factors of safety for both tensile and compressive strains have been determined chiefly from the practice of civil engineers and are adapted to the conditions of fixed structures which have to bear the working loads frequently. There is an important difference between such structures and ships; for the latter have to resist the maximum strains (described in Chapter IX.) only on rare occasions, and probably at long intervals, the strains ordinarily experienced being much less severe. It has been proved experimentally that a severe strain only occasionally applied is not so likely to produce serious damage as a less strain frequently applied especially when the character and intensity of the latter strain are continually and rapidly changing, provided that the maximum strain does not surpass the limits of elasticity of the materials. For these reasons, shipbuilders do not restrict themselves to the factors of safety approved by civil engineers. At present there are no recognised factors for the different classes of ships, but the subject is receiving attention, and from the analyses of the conditions of strain in numerous successful and unsuccessful ships there will probably be deduced, ere long,

useful rules for practice corresponding to those of the civil engineer.

The moduli of elasticity of the two materials afford, perhaps, the readiest means of comparing their relative resistances to both tensile and compressive strains. Professor Rankine gave the following values :—

Materials.	Modulus of Elasticity.
Wrought iron . . .	28,000,000
English oak . . .	1,450,000
Dantzic oak . . .	1,190,000
Dantzic fir . . .	1,958,000
English elm . . .	700,000
Pitch pine . . .	1,226,000
Teak . . .	2,400,000

More recent experiments made in the Royal Dockyards on some of these timbers give somewhat different moduli of elasticity. English and Dantzic oak, for example, had moduli of about 1,900,000—greater than those assigned by Professor Rankine; whereas teak had a modulus of about 1,300,000, or little more than one-half that in the above list. On the whole, however, it seems not unreasonable to accept the average modulus proposed by Professor Rankine, viz. that timber shall be considered to have about *one-sixteenth* the modulus of iron. When iron and wood act together, therefore, this is the ratio which should govern their equivalent sectional areas.* The ratio of weights per cubic foot, it will be remembered, is about 1 for wood to 10 for iron. No further remarks will be needed in illustration of the superior combination of lightness with both tensile and compressive strength, in single pieces of iron as compared with single pieces even of the best timber.

The resistance offered by a combination of pieces of timber to *compressive* strains does not compare less favourably with that of iron than does the resistance of a single piece of timber to that of a single piece of iron, provided only that there is good workmanship in the fitting of the pieces together. This has already been explained in connection with the effective resistance to hogging strains offered by the lower parts of the wood ship illustrated by Fig. 102, page 344. A plain "butt" (or flat end) to two planks or timbers will effectively transmit a thrust, pro-

* See the remarks on page 330.

vided only that the two ends are well fitted to one another, and are prevented from changing their relative positions.

On the contrary, when several pieces of timber have to be combined in order to resist *tensile* strains, their resistance compares much less favourably with that of a combination of iron plates or bars than does the ultimate tensile strength of a single piece of timber with that of a single piece of iron. Against tension a butt-joint is obviously quite ineffective: for in Fig. 102, if any two timbers abutting on one another in a rib or frame were considered to act alone, and to be subjected to a strain tending to separate the butts, they could oppose no resistance except the friction of the dowel, which would be very trifling. If a "strap" of wood or iron were fitted over the butts and bolted to the timbers, it would resist the force tending to open the butts; and it has been shown that the weakness of the butts in any rib

FIG.107

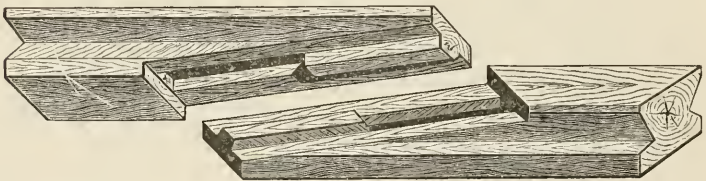

FIG.108



is, so to speak, covered by the strength of the unbutted ribs lying on either side. In many wood ships the timbers of consecutive ribs are bolted together, in pairs, to increase the strength of the frame. In the case of the water-way fitted upon the beam-ends of a wood ship (Fig. 102) the various pieces are plain-butted; but the butts are covered by strong carlings fitted underneath, and to these the water-way pieces are dowelled. This is an exceptional arrangement, however, the almost universal plan adopted where two pieces of timber have to be joined end-to-end, in order to form a tie, being to "scarph" or overlap the ends in some fashion more or less complicated and expensive.

Take the keel, for example, in a wood ship: the adjoining pieces are secured by what is termed a "tabled scarf." Fig. 107 shows the two parts of the scarf, thrown back to exhibit the projecting "tabling" and the sunken recesses into which the tabling fits.

Fig. 108 shows the two parts in place, with the fastening bolts which assist the tabling in resisting tensile strains tending to open the scarph. The plan is an excellent one, but necessitates considerable skill and cost of workmanship in fashioning the scarphs so that they may fit accurately. The same thing is true in the beam-scarphs, illustrated in side view by Fig. 109, and plan in Fig. 110. This is termed a "hooked scarph," metal wedges or keys (*k, k*, Fig. 110) being driven to tighten

FIG.109



FIG.110



up the scarph, and bolts and trenails being used to fasten it. This hooked scarph is of comparatively recent introduction, having replaced the simple but less compact and satisfactory method illustrated in Figs. 111 (side view) and 112 (plan). The fastenings in this case consist of dowels, trenails, and metal bolts. Still another method of scarphing is illustrated in Fig. 113, and is known as a "plain scarph," being free from tabling and hooks. It is not nearly so strong against tensile strains as

FIG.111



FIG.112



the preceding plans; but neither does it involve such care and expense in fashioning. The keelsons, shelf-pieces, and some other longitudinal ties, are frequently scarphed in this manner. It will be noted that in the last plan, and the preceding one (Figs. 111, 112), the fastenings have to contribute the whole resistance to separation of the scarph under tensile strains; and when these strains are acting, there is a tendency for the wood to yield in wake of the comparatively small and hard metal bolts.

The greater hardness and small size of the metal fastenings in a wood ship is one fruitful source of weakness and working.

Parts, at one instant under tension, tend to yield in wake of iron or metal bolts ; soon after, under compressive strains, the tendency disappears, to be followed almost immediately by its reappearance, if the ship is floating amongst waves. It will of course be understood that we are here dealing with tendencies only, and not with actual yielding ; the existence of a large reserve of strength often preventing the tendency from passing into a sensible change of form. When ships are weak, it is otherwise, and then working takes place. It is worth notice, in passing, that the use of timber treenails as fastenings in the outside planking of a wood ship, or of coaks and dowels, also of hard wood, is from this point of view a considerable advantage. Coaks in particular, and treenails in some degree, have a larger "bearing" surface on the wood planks, &c., than have metal bolts ; besides which they are not so hard, both of which differences tend to lessen the local yielding of the pieces fastened by them.

FIG. 113



An assemblage of wood planks or timbers, such as is found in the outside planking, or the flat of a deck, is not usually dealt with by scarphing adjoining pieces together. Plain butt-joints are then had recourse to (see Fig. 100, page 330), and the weakness of the butted strakes on any transverse section is met by the device, previously explained, of "shift of butts." This is, however, tantamount to a reduction of the total sectional area by *one-fourth*, when resistance to tensile strains is being considered ; and the holes for bolts and treenails necessitate a further deduction.

Such are the best results obtained either in timber-ties (like the keel, or beam, or shelf-piece) or in an assemblage of planking. Either scarphing of an elaborate and expensive character must be adopted, or shift of butts must be trusted. In all cases, moreover, the greater hardness and small surface of the metal bolts tends to produce yielding of the wood in wake of them when the parts are under tension.

In every one of these particulars iron gains upon wood. The rivets forming the fastenings of piece to piece are of the same degree of hardness as the plates or bars ; so that yielding in wake of them is not to be feared. What must be secured is that the riveting is properly done, and the holes in the plates, &c.,

well filled by the rivets. Again, when two pieces of iron have to be joined to form a tie, nothing can be simpler than the connection. The pieces may either be lapped and riveted, as in Fig. 114, or butted and strapped, as in Fig. 115. In either case the shearing strength of the rivets may be made to fix the ultimate resistance of the tie to tensile strains. With the lap joints of Fig. 114 the resistance to compression is also measured by the shearing strength of the rivets; whereas in Fig. 115, if the butts are carefully fitted, the rivets in the straps need not sustain any shearing strain under compression, so long as the plates are prevented from buckling. It is usual in iron ships to have butts for the vertical joints of the outside plating, the transverse joints of the deck plating, and other important parts; but the edge joints of the outside plating, which are not subjected to great tensile and compressive strains, are usually lapped, and the edges of the deck plating are sometimes treated similarly.

FIG 114.

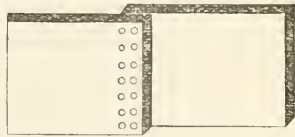
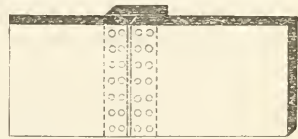

FIG 115.



The butts in a strake of plating are not necessarily such sources of weakness, as are the butts in a strake of planking, because the butt-strap gives great tensile strength to the butts, and may be made to render the section of the plating in wake of a line of butts quite as strong as its section in wake of the lines of rivet-holes at adjacent transverse frames.* Shift of butts is had recourse to also in assemblages of plating, but is of less importance than in assemblages of wood planking. On the whole, in a well-built vessel, the effective sectional area of an assemblage of plating against tensile strains is probably not far from *seven-eighths* of the total sectional area, as compared with *five-eighths* for the skin of a wood ship. It is unnecessary to repeat what was said in the previous chapter respecting the further gain of the iron skin, on account of the efficient edge connections of strake with strake, although this is an important advantage.

Enough has been said to show that it is no exaggeration of the merits of iron to say that whether in single pieces, or in simple

* See a Paper contributed by the Author to the *Transactions* of the Institution of Naval Architects for

1873. The subject is too technical to be discussed in these pages.

ties, or in assemblages of numerous plates, it stands far above wood in its resistance to tensile strains. When exposed to compressive strains there is an undoubted danger of thin iron plates failing by buckling; but this can only happen in an ill-designed ship; the danger is easily guarded against, and when the plating is stiffened by some simple frame or girder, it will compare most favourably with wood in its resistance to compressive strains. A remarkable illustration of failure in an iron ship, by the buckling of her thin plating under compressive strains, is found in the steamship *Mary* (mentioned at page 327). It appears that the topside and deck plating were not sufficiently stiffened for the voyage, and consequently buckled when the ship was astride the wave hollows, their failure bringing upon the more rigid parts of the upper works an excessive strain, which caused the ship to break nearly amidships.

Respecting the third class of strains, those due to bending moments, it is only necessary to add a few words. When a bent beam fails, fracture, as already explained, usually begins either at the upper or lower surfaces. If one of these surfaces is stretched the other is compressed, and *vice versâ*: failure therefore results from the excessive tensile or compressive strains brought upon the bounding layers of material. And for our purpose it will be sufficiently near the truth to assume that the resistance of these layers in the bent beam is very nearly equal to the resistances to direct tension or compression previously stated. It is undoubtedly a fact that in solid beams, like those of wood, of rectangular cross-section, the intimate connection of the parts with one another does somewhat affect the resistance of the bounding layers. For example, Professor Rankine gives the following values:—

Timbers.	Strengths in Pounds per Square Inch.		
	Tensile.	Compressive.	Cross Breaking.
Dantzic oak	12,780	7,720	8,740
Jamaica mahogany	8,800	16,600
Pitch pine	7,800	..	9,800

Such considerable differences are, however, the exceptions rather than the rule, and do not appear in the timbers most used.

With the flanged forms obtainable in wrought-iron beams, similar variations are not likely to occur, and there is no sensible error in assuming that the ultimate resistances of the flanges

correspond to the tensile and compressive strengths obtained by direct pull or thrust.

A few examples of the great variety of forms in which iron beams are made will be found in Fig. 116. It is unnecessary to repeat what has already been said as to the increased strength to resist bending obtained by using these flanged forms, instead of the solid rectangular sections which are unavoidable with wood.* But it may be proper to mention that this essential difference between wood and iron affects the relative efficiencies not merely of deck beams, but also of ribs, longitudinal frames or strengtheners, pillars, and many other parts of the structure of a ship.

FIG 116.

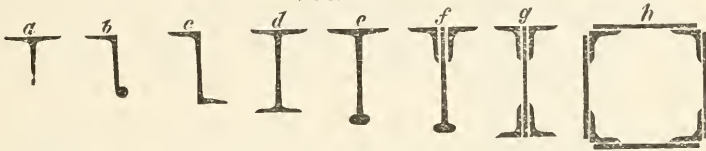

References.

- | | | |
|---|--|---|
| <p>a, T-iron.
b, angle-bulb.
c, Z-iron.
d, H-iron.
e, T-bulb.</p> | | <p>f, bulb-plate with angle-irons.
g, made-beam.
h, box-beam.</p> |
|---|--|---|

The simple angle-iron is sometimes used as a beam ; its form may be seen from the sections *f*, *g*, *h*, in Fig. 116, and differs from the T-iron in having a top flange on one side only of the vertical web. Neither the angle nor the T form is well adapted for resisting bending strains, because of the absence of a bottom flange. The angle-bulb (*b*) is a great improvement in this respect, and is used for light decks or platforms as well as under completely plated decks. Z-iron (*c*) is used for frames behind armour in ironclads, for transverse framing, and for longitudinal stiffeners, but not often for beams. H-iron (*d*) is expensive, and is not used so much as the made-beam (*g*) of similar cross-section. Not unfrequently, instead of having double angle-irons on the upper edge of the made beams, to a deck covered with iron or steel plating, only single angle-irons are worked, a portion of the deck plating above the beam then forming the upper flange. Sections *e* and *f* may be regarded as interchangeable: the latter was formerly much in use,

* See page 373 as to beams; also page 369 as to ribs.

but since the iron manufacturers have made such advances as to be able to produce the section *e* with ease, and at moderate cost, the shipbuilder naturally prefers to obtain the finished form. The boxbeam *h* is only used where exceptional strength is required, to support some concentrated load, or to furnish a very strong tie. Of the other sections sometimes used it is needless to speak; they all, or nearly all, exhibit the general characteristic of top and bottom flanges, or bulbs connected by a thin vertical web. Even for the largest ships, beams of these sections are now procurable in one length, which is another great advantage as compared with the two-piece or three-piece wood beams required in large ships.

A practical rule, not pretending to exactness, for comparing the strengths of beams may have some interest. For the flanged iron beams such as are generally used in ships, the ultimate breaking strength of any cross-section may be expressed approximately by the formula

$$\text{Breaking strength} = 20 \text{ tons} \times \text{sectional area} \times \frac{\text{depth}}{3}.$$

The sectional areas being expressed in *square inches*, and the depths in *inches*, the breaking strength will represent a moment in *inch-tons*. For example, take a beam of section *d*, Fig. 116, suppose it to be 12 inches deep, and its top and bottom flanges to be each 6 inches wide, the web and flanges being $\frac{1}{2}$ inch thick. Then, approximately,

$$\begin{aligned} \text{Breaking strength} &= 20 \text{ tons} \times (12 + 6 + 6) \frac{1}{2} \times \frac{1}{3} \times 12 \\ &= 960 \text{ inch-tons.} \end{aligned}$$

For a solid wood beam of rectangular cross-section the approximate rule for teak or oak would be,

$$\text{Breaking strength} = 3 \text{ tons} \times \text{sectional area} \times \frac{\text{depth}}{6}.$$

The weight of the iron beam taken as our example would be about 40 lbs. per foot of length, the sectional area of a teak beam of equal weight would be about 120 square inches: suppose it to be 12 inches deep by 10 inches broad. Then

$$\begin{aligned} \text{Breaking strength (approximate)} &= 3 \text{ tons} \times 120 \times \frac{1}{6} \\ &= 720 \text{ inch-tons.} \end{aligned}$$

As regards ultimate strength, the iron beam is therefore one-third stronger than the wood beam of equal weight. But here the necessity for taking account of working strengths as well as

breaking strengths must be remembered. The comparatively large factors of safety required with timber increase the advantages of iron, even when each beam is in a single piece. The scarpings of the wood beam further detract from its strength in wake of them. And, moreover, it must not be overlooked that, while the strength of the iron (20 tons per square inch) may be safely looked for, the strength of the wood may vary over a very extensive range.

Putting the working strengths instead of the breaking strengths, the case stands approximately as follows:

Working strength of iron beam =

$$4 \text{ tons} \times \text{sectional area} \times \frac{\text{depth}}{3}.$$

Working strength of wood beam =

$$\frac{3}{10} \text{ tons} \times \text{sectional area} \times \frac{\text{depth}}{6}.$$

Weight of timber (per cubic foot) = (say) $\frac{1}{10}$ weight of iron.

Sectional area of timber beam = 10 times sectional area of iron beam of equal weight.

Hence, finally, for *equal weights* and *equal depths*,

$$\frac{\text{Working strength of iron beam}}{\text{Working strength of wood beam}} = \frac{4 \times 1 \times \frac{1}{3}}{\frac{3}{10} \times 10 \times \frac{1}{6}} = 2\frac{2}{3},$$

which represents a very considerable gain in favour of iron.

Besides being procurable in single pieces of a flanged form, iron plates and bars can be combined readily to produce that form; on the other hand, wood must be used in rectangular or, at least, solid timbers, and cannot readily have many pieces combined into a flanged form. Examples of this difference have already been given. Refer, for instance, to the contrast between the solid timber ribs spaced closely in the wood ship (see Fig. 102, page 344) and the flanged transverse frames with the adjoining segments of plating in the iron ship (Fig. 103, page 346). As another contrast, compare the strong longitudinal frames or girders, to which the adjacent parts of the inner and outer skins form flanges in the ironclad ship (Fig. 104, page 351), with the solid binding strakes or keelsons of a wood ship. Many other illustrations of the facility with which iron can be thrown into the form best adapted for resisting bending strains will present themselves to the student interested in the detailed structural arrangements: but we cannot now enlarge upon this important feature. Nor need we do more than recall attention to the fact

that when the ship, as a whole, is treated as a girder resisting longitudinal bending moments, the component parts of the flanges in that girder are mainly exposed to tensile and compressive strains, in resisting which iron gains upon wood in the manner explained above; the web of the girder is simultaneously subjected to racking or distorting strains, against which the superior edge connections in an iron ship make the skin greatly more efficient than the skin of a wood ship.

From this brief sketch it will be understood why iron ships are lighter in proportion to their strength than wood ships of the same form and dimensions; as also why it is possible with iron to construct ships of sizes, proportions, and speeds unattainable with wood. It is, of course, possible by ill-considered structural arrangements to throw away much of the advantage that may be gained by using iron hulls. Bad combinations, improper distribution of the material, imperfect fastenings, and other faults may lead to the production of weak, yet heavy, iron ships. In order that a fair comparison may be made between the capabilities of the two materials it is, however, necessary to assume that the best use is made of both.

Next, as to the comparative *durability* of iron and wood ships. For some years after the introduction of iron ships this was a matter of dispute, but lengthened experience has settled it definitively in favour of iron. Ships properly constructed of that material, and properly treated during their service, suffer but little deterioration during long periods. Wood ships, on the contrary, even when constructed of well-selected and seasoned timber, and carefully used, are, as a rule, subject to comparatively rapid decay. Many examples may undoubtedly be found of greater durability in wood ships, but these are exceptional cases; and, moreover, their occurrence has not put within the power of shipbuilders any means by which similar durability can be secured in other wood-built ships. For instance, the *Sovereign of the Seas*, built at Woolwich in 1635, is said to have been pulled to pieces forty-seven years later, the greater part of the materials having been found in such good condition as to be used in rebuilding her. Still more notable is the case of the *Royal William*, built about 1715, which remained on service for ninety-four years with only three slight repairs. Both these vessels were built of oak felled in the winter, and much importance was attached to this circumstance; but later experience in the *Hawke* sloop, built in 1793, threw some doubt upon the previous conclusion, the

vessel having fallen into such a state of decay in ten years that she was taken to pieces.*

The very numerous schemes for preventing dry-rot and other kinds of decay in timber, which were proposed and tried prior to the introduction of iron ships, afford ample evidence that these cases of long-continued service were not common. These processes are now matters of history only, and will not be discussed; but there appears reason to believe that, on the whole, the best results as to durability, were obtained with ships built of well-selected materials, which were allowed to season naturally, prior to being used in the ship, and after she was in frame.† This last-named condition of course involved slow progress with the construction of a ship, and was scarcely likely to have been fulfilled in the mercantile marine at any period; but in the Royal Navy, in the earlier half of the present century, it was frequently fulfilled, and some of the ships then built proved very durable.

With such varying conditions—depending upon the selection of the timber, the circumstances of its growth, the season when it was felled, the processes of seasoning, preservation, &c.—it will be readily understood that it is not an easy matter to assign the average durability of wood ships. Probably experience with ships of the Royal Navy prior to the general introduction of steam propulsion or the use of iron furnishes the best data for forming a just estimate; for the subsequent changes in *matériel*, from sailing to unarmoured steam ships, from these again to iron-clads, and from wood hulls to iron, have all tended to introduce other conditions than those of fair wear and tear into the cessation of the service of wood-built ships. In 1841 Mr. Chatfield read a paper before the British Association, at Plymouth, in which he stated, as the result of careful examination, that thirteen years was the average time during which wood-built war-ships remained efficient when employed on active service, and receiving ordinary repairs at intervals. Experience in the French navy points to a very similar term of service for wood ships. Moreover, the Rules for Wood Ships issued by the Committee of Lloyd's Register, and guiding the construction of by far the greater number of wood merchant ships, allow from twelve to fourteen years as the

* See the remarks of Mr. Ambrose Bowden, quoted by Mr. Laslett at pages 68-70 of *Timber and Timber Trees*.

† It may be interesting to mention that Lloyd's rules for wood merchant ships strongly recommend the practice of "salting" the timbers, beams, &c.

average period of durability to be assigned to the best descriptions of shipbuilding timber when properly seasoned and free from defects. Less satisfactory materials, used in subordinate parts of ships, or in vessels of inferior classes, have considerably shorter periods assigned, ranging so low as from four to six years.

Under the most favourable conditions, therefore, the average durability on active service of well-built wood ships, fairly used and kept in good repair, may be taken at from twelve to sixteen years. It has been shown that in some cases much greater durability has been obtained; and, on the other hand, many instances might be cited where vessels hastily constructed of unseasoned or unsuitable timber have fallen into decay in half, or less than half, the average time of service named. It is, of course, understood that the period of service is considered to expire when the cost of the repairs would be so heavy, if they were thorough, as to make it more economical to replace the worn ship by a new one. In the United States navy, for example, many wood vessels, built with the greatest possible rapidity during the Civil War, were condemned after only six or eight years of service; while others, on which work had been suspended, actually rotted on the stocks. The hurried construction, and use of any materials that could be procured, were undoubtedly the chief cause of the rapid decay; and on the other side of the picture may be placed the durability of the earlier screw frigates of the American navy, which remained efficient for periods exceeding the average given above. Very similar results followed the hurried construction of the gunboats built for the Royal Navy during the Crimean War; they speedily fell out of service.

Recent experience with the wood ships of the Royal Navy may be quoted in support of the views expressed.* Taking the unarmoured wood ships, from frigates downwards, it appears that after ten to fifteen years of service they have reached such a condition as to render it impolitic to repair them. Special requirements have kept a few such vessels on service for longer periods; but no injustice is done to the class in fixing sixteen years as the general upper limit of durability for sea-going wood ships.

Ironclad wood-built ships are no longer-lived; in fact the conditions in these ships are, on the whole, less favourable to durability than they are in unarmoured ships. Nearly all the

* See *Parliamentary Paper* (No. 297) of 1876, of Vessels Launched, Broken up, Sold, &c., from 1855.

converted ironclads of the Royal Navy (*Caledonia* class) dating from 1861, but not actually on service until two or three years later, are now either on the Harbour Service List or else in such a condition as to render their repair inexpedient. So also is the *Lord Clyde*, which is about two years younger. In the French navy, also, very similar steps have been taken, the earlier wood-built ironclads having been struck off the effective list. The Italian navy furnishes still further examples, and so does the Austrian; but it is unnecessary to multiply illustrations of the comparatively speedy decay of wood ships. Even when all possible care has been taken in their construction, hidden sources of decay may exist in the structure, and sooner or later produce serious results. No certain length of service can be guaranteed under these conditions to any wood ship; and not unfrequently it happens that, in the examination of some apparently trifling defect, the discovery is made of much more serious and unsuspected decay, leading in some cases to the condemnation of the ship as unfit for further service. With iron ships the conditions are quite different, as we will now proceed to show.

Iron is not subject to those internal sources of decay to which timber is liable: nor is it subject to the attacks of worms or marine animals which can penetrate the comparatively soft planking; nor is it liable to rot in consequence of imperfect ventilation or other causes. Moreover, in a well-built iron ship there ought not to be any sensible working; whereas in wood ships, however carefully constructed, the connections and fastenings must, as we have shown, be less satisfactory; the entire prevention of working is practically impossible, and in such working is found a fruitful source of weakness or decay. Corrosion or rusting of the surfaces is the special danger requiring to be carefully guarded against in iron ships; and it is by no means insignificant in its character. Both outside and inside, an iron ship is constantly exposed to conditions tending to promote corrosive action. The above-water parts of the hull are the least likely to suffer; but even these, on the outside, have to resist the effects of air, water, and weather, and in the inside are exposed to changes of temperature, the condensation of vapour, and other circumstances productive of rust, if left unchecked. The under-water parts of the hull are much less favourably situated. Outside, the bottom plating is immersed in corrosive sea-water; and inside, the plating, frames, &c. are to some extent exposed to bilge-water, often very corrosive in its character, to the chemical action of coal or other substances carried in the hold as cargo, and

not unfrequently to galvanic action produced by metallic connection with pipes, &c., of copper, brass, or lead, immersed in the same bilge-water as the iron. Moreover, in steamers there are the great alternations of temperature in the parts adjacent to the boilers and engine-room, the condensation of steam upon the surfaces of the iron, and the production of gases more or less effective in aiding corrosion. Adding to these extraneous causes the generally admitted facts that in iron, such as is used for ship-building, the want of homogeneity in the various parts of the same plate or bar may cause corrosion to begin, or accelerate its progress; and that when rust has once formed it tends to propagate itself, eating deeper and deeper into the iron affected, it will be evident that watchfulness and precaution are needed to ensure the preservation of iron ships. Their durability, in short, is not a result to be assumed as an intrinsic quality; but they differ from wood ships in this important feature:—with care and proper treatment they can, at moderate expense, be maintained in a sound and efficient state for very many years; whereas wood ships cannot be so maintained without an unwise outlay. The causes of decay in the iron ship lie upon the surface, and are to a great degree preventable: those in the wood ship are deep-seated, difficult to discover, and practically incurable in the parts attacked. A corroded plate or bar can be scraped free from rust, cleaned and painted; and if corrosion has not proceeded far before such measures are taken, it is little or nothing the worse. On the contrary, a rotten timber or plank must be wholly or partially removed, often with very considerable difficulty. Neglect of preservative measures, of course, leads to the rapid decay of both iron and wood ships; but when the best is done for both, iron proves immensely more durable than wood.

General experience in mercantile and war fleets places this fact beyond dispute; but it does not yet enable one to fix an average of durability for iron ships, properly treated, corresponding to the average previously stated for wood ships. This is due, in part, to the comparatively short time that iron ships have been in general use: forty years or so, when contrasted with the lifetime of some existing iron ships, being a period too short to give data for fixing an average. Besides, it must be remembered that experience was necessary in order to determine what measures were best adapted to preserve iron ships, and what methods of construction most favoured such preservation. Even at the present time opinions on these matters are by no means unanimous. But certain points are settled which, at the outset,

were uncertain, and in all probability the durability of ships built on these later methods—favouring the accessibility for inspection of all parts of the hull, and the isolation of the outer skin from many causes of corrosion by means of a double bottom—will prove greater than the durability of ships of earlier types. Hence the determination of the average durability of iron ships must be postponed to a later date.

Many of these early iron ships, however, proved very durable. Mr. Grantham records that the *Aaron Manby*, the first iron steam-vessel, built in 1821, lasted thirty-four years; the *Garry Owen* and *Euphrates*, river steamers, were in good order after twenty-four years' service; the *Nemesis* and *Phlegethon*, the earliest iron war-ships built for the East India Company in 1839, were still at work twenty years after; and many other similar cases are known.

Turning to existing iron ships, no less notable results may be stated; but only a few can be given. The *Great Britain*, merchant steamer, was built in 1840, but is still afloat (1882). In the Royal Navy the troopship *Simoom* is thirty years old, but is still on active service. The *Himalaya* won golden opinions during the Crimean War, has been almost continuously employed since, and is quite as popular now as she was twenty-five years ago. The *Warrior* and other iron-built ironclads, dating from 1859–61, are yet strong and sound; whereas their wood-built contemporaries in the French and British navies have fallen into decay. In the navy of the United States very similar experience has been obtained. The iron-hulled monitors which were on service during the Civil War remain on the effective list; but the wood-built monitors of later date have fallen into decay, and are being replaced by iron. Curiously enough, in some of these iron vessels wood beams were used, in consequence of the difficulty of procuring iron beams; and thus a very good illustration has been given of the comparative durability of wood and iron. The wood beams decayed after eight or ten years, and were then replaced, at considerable cost, by iron beams; the iron hulls meanwhile, although much neglected for a time, are said to have suffered no serious loss of efficiency.

Durability, in the sense we have used the term, is determined by the period which elapses before repairs become too expensive to be undertaken. Repairs to an iron ship are not nearly so difficult or expensive as in a wood ship; and therefore the limit of economical employment would not be so soon reached in the iron ship as in the wood, apart from the less rapid decay. On

the other hand, the comparative thinness of the skin of an iron ship makes even a small loss of thickness important; and, what is perhaps of greater importance, corrosion is not uniform nor regular in its character over the whole surface of the bottom, but often becomes localised, "pitting" the iron plates in places. The rate of corrosion depends upon so many and such varying conditions that no general law can be assigned. For example, the same ship exposed to the action of differently constituted sea-waters will be corroded at different rates. The existence of galvanic action also rapidly accelerates and localises corrosion; and two plates or bars of iron apparently similar in quality are often found to be very differently affected by corrosion, as are also different parts of the same plate or bar. It lies outside our present purpose to attempt any discussion of this subject beyond what has been done, but obviously the practical deduction to be drawn from this want of regularity in the rate of corrosion of iron ships is simply this:—to prevent serious corrosion, careful and frequent inspections are necessary of all parts of the hull, particularly of those situated below the water-line. Experience confirms the view that where such inspections are made, and the surfaces of the iron are kept protected by paint, varnish, or cement, the rate of corrosion may be made very slow. This broad general deduction is far more important than the deductions made from laboratory experiments on the loss of iron by corrosion under various conditions, although these experiments have a certain value.*

The outer bottom plating of an iron ship, liable as it is to corrosion on both surfaces, furnishes one of the best tests of the possibility of lessening corrosion by the means just mentioned. In the ships of the Royal Navy, when undergoing thorough repair, it is usual, after they attain a certain age, to ascertain the decrease in thickness of the plating by careful drilling and measurement. When thus treated a few years ago, it was found that the *Simoom*, then over twenty years old, required only a small number of new plates in her bottom, by far the larger number of the plates having maintained sufficient thickness to be safely trusted for further service. It is also worthy of mention

* An excellent summary of such experiments is contained in a Paper contributed by the late Mr. R. Mallet, F.R.S., to the *Transactions* of the Institution of Naval Architects for

1872. Some of the conclusions from those experiments stated by Mr. Mallet appear, however, scarcely consonant with the results of experience with iron ships.

that as yet (1882) not a single bottom plate in any of the iron-built ironclads of the Navy has had to be renewed in consequence of corrosion, although some of these vessels have been afloat twenty years. Lloyd's Rules, the highest authority that can be quoted for merchant ships, being based upon a very large range of experience, fully recognise the slow progress of corrosion in iron ships properly treated. Therein it is provided that, when an iron vessel is twelve years old, she is to be thoroughly surveyed, and all rust removed, the thickness of her plating being ascertained by drilling: where the loss in thickness exceeds *one-fourth* of the original thickness, new plates are to be fitted. Surveys made at intermediate periods are trusted to discover any local wearing or pitting, and it is not until another twelve years have elapsed that another searching investigation is required. No absolute limit is placed upon the period of service, the Rules providing that vessels will be classed "so long as on careful annual and periodical "special surveys they are found to be in a fit and efficient "condition to carry dry and perishable cargoes to all parts of the "world."

Laboratory experiments upon the loss of thickness in iron plates subjected to the action of sea-water do not furnish trustworthy data from which to compute the durability of the bottoms of iron ships; and this for two reasons. The actual condition of service in a ship cannot be represented, nor can all the variations in quality of the iron be tried. To state the *mean* loss in thickness for a certain period, as already remarked, is very misleading, since local wear or "pitting" takes place, and may penetrate deeply into a small portion of a plate of which the general surface is but little worn. In iron vessels of considerable age it is not uncommon to find local patches of corrosion, at which the reduction from the original thickness of plates is twice or thrice as great as the average reduction. Galvanic action exaggerates local wearing: if a copper suction-pipe, for instance, dips into the bilge-water which lies upon the inner surface of the bottom plating, and this pipe and the plating are joined by ever so circuitous a metallic connection, galvanic action will be set up and the iron plate near the suction-pipe will waste. Cases are on record where by this means holes have actually been worn completely through the bottom of an iron ship, which in other respects was satisfactory; but this kind of action is wholly preventible when proper precautions are taken. Pitting due to other causes is not wholly preventible, but it may be much lessened by careful selection of the iron plates used on the

bottom, and by careful and frequent inspection, scraping, and painting of the surfaces.

To show how limited is the use of laboratory experiments, one example may be given. One careful experimenter (Mr. Malle) estimated from his experiments that the mean loss in thickness of iron plates immersed in foul sea-water was rather over $\frac{1}{2}$ inch ($\frac{5.3}{100}$) in a century: two other careful investigators (Dr. Calvert and Mr. Johnson) reached the conclusion that the corresponding loss would be about $\frac{5}{8}$ inch ($\frac{6.1}{100}$). The mean result for all these experiments would therefore be $\frac{5.7}{100}$ inch as the loss of thickness in a century; which would be less than the actual thickness of the bottom plating of a large number of iron ships. As a matter of fact, however, many cases are on record where, without pitting, iron plates on the bottoms of ships have worn much more rapidly. In the *Megæra*, for example, when fifteen years old, many plates were found to have become reduced $\frac{1}{4}$ inch from their original thickness; and if this rate of wear had been maintained, the loss in a century would have been not much less than thrice as great as that given by the laboratory experiments. It is, of course, quite conceivable that under other conditions the wear in the *Megæra* might have agreed with the laboratory experiments; but neither such experiments nor actual results on ships can furnish any *general law* for the rate of corrosion.

The Regulations issued by the Admiralty for the preservation of iron ships contain the best summary of the precautions necessary for that purpose with which we are acquainted. As the circulars on this subject are generally accessible, it will be sufficient to summarise the main points. *Galvanic action* of copper, brass, or lead upon the iron hull is to be prevented by making the lower pieces of suction-pipes, &c., which are immersed in the bilge-water, of iron or zinc or zincked iron wherever that is possible. Where copper or brass pipes are unavoidable, they are to be well painted or varnished and covered with canvas in order to reduce their action on the iron. The gun-metal screw-propellers are also to be painted for the same reason, and bands of zinc, termed "protectors," are to be fitted near them, in order to concentrate the galvanic action of the propellers upon the protectors and save the bottom plating: this plan has answered admirably. In order to preserve the *inner* surfaces of the bottom plating below the bilge from the injurious effects of the wash of corrosive bilge-water from side to side as the ship rolls, cement is used, and has proved of great advantage to both merchant and war ships. Other surfaces of plates and bars in the interior are pro-

tected by suitable paints or compositions. All parts of the hull are ordered to be made as accessible as possible for inspection and repairs. In cases where parts are necessarily inaccessible under ordinary circumstances—such as under the boilers or engines, &c.—careful records are to be kept of them; and when opportunity offers, as during a thorough repair at a dockyard, all such parts are to be opened up and inspected. When a ship is in the reserve or on service, all accessible parts are to be inspected once a quarter, cleaned and painted when necessary. Annually a more thorough survey is to be made, by dockyard officers when possible; and then the only parts to be left unvisited are those which cannot be reached without great difficulty—as, for instance, spaces which can only be attained by lifting the boilers or machinery. The use of double bottoms facilitates a thorough examination; especially of the inner surface of the outer plating, and all the parts of the inner plating underneath engines and boilers. The outer surface of the bottom plating is to be sighted at least once a year; it is protected by some anti-corrosive paint or composition, and if the annual examination shows it to be necessary, this protective material is renewed.

Such are the main points in the Admiralty Regulations. Conformity to them must prevent any serious corrosion taking place: for rusting ought to be detected in its earlier stages, and the surfaces, being frequently cleaned and coated, ought not to suffer greatly. The system has now been in force for some years, and has worked most satisfactorily. In a modified form it is applied also to the preservation of the ironwork in the composite ships of the Royal Navy.

Thirdly, iron ships gain upon wood in being more easily and cheaply built and repaired. Upon this division of the subject but few remarks will be necessary, although it has great practical importance.

Timber is only obtainable by the shipbuilder in pieces of which the forms and dimensions are limited by causes beyond his control; and the greatest care has to be bestowed upon the “conversion” of the logs, in order to get out of them the best possible finished timbers. For some parts of a ship where the curvature is considerable—as, for instance, the ribs—it is not unfrequently a matter of difficulty to procure suitable timber. Even when a good choice has been possible, considerable labour and skill have to be expended on fashioning the pieces; and we have shown how difficult it often is to effect a good combination

of piece with piece. Manual labour is, moreover, almost a necessity in the greater part of the work of building a wood ship.

Iron, on the contrary, is obtainable by the builder from the manufacturer almost of the sizes and forms required, the dimensions of the pieces and their sectional forms being limited only by the powers of the manufacturer, which continually increase as the demand increases. The progress already made is most remarkable, and there are yet no signs of the limit having been reached. Less than twenty years ago an armour plate which weighed 5 tons was considered heavy; now (1882) plates are commonly made weighing 20 or 30 tons, and plates of 40 or 50 tons can be produced if desired. Another example is furnished by the manufacture of wrought-iron beams. Formerly the sectional form *f* in Fig. 116, was largely used, and the section *e* was made with difficulty by a special process: now *e* can be rolled easily, even in the largest sizes. The section *e* also has replaced, to a large extent, a girder formed by a plate with a single angle-iron on each edge. But it is needless to further illustrate a well-known fact: the progress of the iron manufacture tends towards the production of finished sectional forms, and the avoidance of cost and labour in combining plates and angles to produce such forms.

In building an iron ship, less work is also required in fashioning and combining the pieces than is the case with wood. Beams, for instance, in the iron ship are given to the builder in one length: costly scarphs like those in Figs. 109 and 110 are unnecessary. Bending takes the place of the costly fashioning required for the curved pieces of a wood ship. Welding, lapping, and butt-strapping replace scarphing. And, what is no less important, machinery can be, and is, extensively employed in the preparation of the parts of an iron ship.

Any one who has witnessed the rapid progress on the framing of an ordinary iron ship, as compared with that on the erection of the ribs of a wood ship, cannot fail to have noticed the much greater simplicity of the operations required in the iron ship. And although in a vessel built on the longitudinal system of framing (see Fig. 104, page 351) the operations of construction are less simple than those in an ordinary iron ship, yet even here all that has been said above applies; individual pieces are procured of the forms and dimensions desired, they are combined simply, and the work admits of being pushed on rapidly.

Iron ships are also much more easily repaired. All, or nearly all, the surfaces of the skin-plating, as well as those of the trans-

verse and longitudinal framing, in these ships may be, and should be, made easily accessible for inspection: for which purpose it is highly desirable that the inside planking (or "ceiling") should be arranged in such a manner as to be readily removed. In case of damage, therefore, the injured parts can usually be reached, examined, and replaced without any great difficulty. Wood ships, on the contrary, are not so readily examined or repaired. The various parts are so closely associated, interlaced, overlapped, and fastened, as to render a considerable disturbance unavoidable if any considerable repair is needed. It is, for example, a task of some difficulty and expense to replace a rotten timber in the framework by a sound one, and when a vessel has been aground and had her bottom seriously damaged, the cost and difficulty of the repair must be considerable.

From many notable examples of the ease with which the repairs of iron ships may be effected, a few may be selected. The *Great Britain* was for many months ashore in Dundrum Bay, and although the bottom was battered by beating upon the rocks, and the boilers were forced up about 15 inches, yet the damage was almost confined to the lower part of the hull, her form remained unaltered, and she was got off and repaired. The *Tyne*, an iron steamer, ran ashore on the south coast, and remained for several months in an exposed position; but she too was ultimately floated and repaired, being made as strong and sound as ever, although a large portion of her keel had been torn off and her floor much injured.* The *Great Eastern* furnishes still further proof of the ease with which an iron ship can be again made efficient after serious damage to her bottom; † and in the Royal Navy one meets with similar cases. The *Agincourt* was easily repaired after running on to the Pearl Rock; and the *Bellerophon* and *Northumberland* were again restored to efficiency without large expenditure after being injured by collision. Still more remarkable are the cases, of which several have been brought to our knowledge, where iron ships which have grounded and broken in two, have subsequently been floated, the separated parts reunited, and the ships again employed successfully. We regret that limited space prevents any details being given of these occurrences.

* Mentioned by Mr. Grantham in his work on *Iron Shipbuilding*. Much interesting information respecting the accidents to the *Great Britain* and

Great Eastern will be found in the *Life* of Mr. I. K. Brunel.

† See the remarks on page 29 as to the accident to that ship.

Further, iron ships, under the ordinary conditions of service, require much less expenditure on repairs than wood ships, in order to meet wear and tear. This is a matter not admitting of question. It is, of course, difficult to speak with certainty as to the comparative costs; but probably it is within the truth to say that, on an average, the deterioration in a wood ship is not far from twice as great as that in an iron ship, in equal times, and under similar conditions of service. The usual allowance for wood ships is that in from twelve to fifteen years the casual repairs to meet ordinary wear and tear of the hull, apart from accidents, would about equal the first cost; for iron ships the corresponding term would probably be twice or thrice as great. The Parliamentary Returns for the Royal Navy confirm this view, only the figures given represent total outlay upon maintenance, repair, and alterations in the hull, machinery, armament, &c., and therefore tell against the iron hull considered separately. This being understood, the following figures will be interesting. During the eight years 1866-74 over £124,000 in all was spent upon the maintenance and repair of the *Warrior*—a large sum, doubtless, but corresponding to an average annual outlay of about *one twenty-fifth* part only of the first cost—although this period represented what would have been the latter half of the average life of a wood ship. The same proportionate outlay occurred also in the *Defence* and *Resistance*, which, like the *Warrior*, date from 1859-60. Ships of less age, of course, cost proportionately less. The *Bellerophon*, for instance, in these eight years, being new, only had spent upon her annually, on an average, about *one thirty-third* part of her first cost, and this included repairs after her collision with the *Minotaur*. In their first five years of service the *Invincible* class cost annually only about *one-eightieth* part of their first cost. While these examples are not exactly to the point, they furnish a confirmation of the views expressed above; for the boilers and machinery are subject to greater wear and tear than the hull, and the cost of alterations in fitting or equipment is not fairly chargeable to repairs.

The relative first cost of constructing wood and iron ships is a matter upon which it is not easy to pronounce definitely. Some authorities have estimated that in merchant ships the saving by using iron instead of wood must amount to quite 10 per cent.: others have asserted that, on the whole, in iron sailing-ships merchandise can be carried at least 25 per cent. more cheaply than in wood ships of equal size. But obviously the relation between the first costs is not the sole, nor even the chief, condi-

tion in the determination of the relative economies of the two classes of ships; and the changes in the prices of materials from time to time must greatly influence that relation. For example, when iron was so dear a few years ago, wood sailing-ships of moderate size were much in request because they were cheaper than iron ships: but even under those unusual conditions no attempts were made to reinstate wood in the construction of the largest sailing ships, much less in that of steamers. In short, as has been previously said, it is a question of the *possibilities* of the two materials which has determined the shipbuilder to abandon wood: with iron he can achieve results not attainable with wood, and he would be justified in incurring greater first cost in building iron ships, even were that additional expense necessary. In proportion to their commercially remunerative powers, iron ships are not dearer than wood; and in judging of these powers, one has to consider, besides first cost, the durability of the structure, probable expense of repair and maintenance, carrying-power for cargo, &c. In war ships, instead of cargo, there have to be carried weights of armour and equipment; and it is quite conceivable that, to gain a permanent superiority in this carrying-power, it would be really economical in the end to incur a greater first cost. These considerations apply with greater force to the comparison of steel and iron ships than they do to that of iron and wood ships, as will appear farther on.

The last feature of superiority in iron ships to which reference will be made is their *greater safety* when properly constructed. Against all ordinary risks of foundering at sea iron ships may be secured by efficient watertight subdivision, such as has been described at length in Chapter I. It has there been remarked that in very many cases other considerations are allowed to override those of safety; iron ships being built with so few bulkheads as to be practically destitute of any provision against foundering, other than the strength of the skin-plating and the decks. But this failure to introduce bulkheads, in order to obtain large cargo-holds, of course detracts in no measure from the possible safety of iron ships. Much the same may be said of the doorways and other openings cut in the bulkheads for convenience of passage from one compartment to another: these openings may be provided with watertight covers, but if they are not closed when accidents happen, the efficiency of the system of subdivision obviously ought not to be discredited in consequence. Again it is possible, either by defects of workmanship or by wear

and tear in service, for a partition presumably watertight to be really not so: such defects are, however, easily discovered by testing, and are not difficult to remedy.

All that need be said, therefore, on this head is, that when the internal space of an iron ship is subdivided into numerous compartments by longitudinal or transverse partitions rising to a sufficient height, or by horizontal platforms, or an inner skin, and all such partitions are really *watertight*, then that ship is safer than any wood ship would be against foundering.

It is needless to quote instances of the insufficiency of the subdivision practised in most iron merchant ships: they are, unfortunately, of too common occurrence; accidental, and perhaps slight, collision leading to the rapid sinking of one or both of the ships. The ill-fated troopship *Birkenhead* is a case wherein the original subdivision was satisfactory, but was marred by cutting openings in the partitions, in order to make more easy the passage from compartment to compartment in the hold. In the *Vanguard*, according to the evidence given at the court-martial, the doors in some of the bulkheads were open when the ship was struck by the *Iron Duke*, as they naturally would be under the circumstances; although, had the ship been expecting a collision, as in action, the doors would either have been closed or held in readiness for closing. Some difficulty was experienced in closing the doors in the *Vanguard*, and the results were very serious, as the steam-pumps could never be brought into operation. Finally, as a case where the watertightness of a partition proved of great importance, reference may be made to a case which happened some years ago. On survey it was found that the bulkheads of a steamer were not watertight; and they were ordered to be made so. Almost immediately after, the vessel was struck by another, and seriously damaged on the fore side of a bulkhead, which had been caulked, the watertightness of which prevented any passage of water farther aft, and kept the vessel afloat, bringing her passengers and freight safely into harbour.

Bulkheads in iron ships have also proved themselves of great value against fire. The well-known case of the *Sarah Sands* illustrates this. The nature of the material in their hulls gives to iron ships a greater degree of safety from fire than wood ships; although the existence of wood decks, inside planking, fittings, &c., somewhat detracts from this superiority. In the *Sarah Sands*, when employed as a troop-ship, and far away from land, a serious fire in the after part of the ship was kept from spreading by the existence of a bulkhead, upon one side of which

cold water was thrown in large quantities; and although the vessel was much damaged, she was kept afloat and the lives of those on board were saved, which could scarcely have been hoped for had such a fire broken out in a wood ship.

Turning to the other side of the picture, brief reference must next be made to the *disadvantages* attending the use of iron ships. These are twofold: easy penetrability of the thin bottom by any hard pointed substance, and fouling of the bottom. Respecting the former, it is only necessary to refer to the remarks made in a previous chapter (page 315), and to add that the use of a double bottom completely overcomes the difficulty, while it would be unwise to attempt to meet it, as some persons have suggested, by greatly increasing the thickness of the outer bottom plating.

Fouling is a much more serious drawback to the use of iron ships. Wood ships with copper sheathing on their bottoms can keep the sea for very long periods with a comparatively small increase in resistance, and loss of speed, due to their bottoms becoming dirty. Iron ships, on the contrary, even when their bottoms are covered with the best anti-fouling compositions yet devised, cannot usually remain afloat more than a year without becoming so foul as to suffer a serious loss of speed; and very frequently a much shorter period suffices to produce this condition. The prevention of fouling has naturally attracted much attention; numberless proposals having been made with the object of checking the attachment and growth of marine plants and animals, which go on more or less rapidly on iron ships in all waters, and especially in warm or tropical seas. Various soaps, paints, and varnishes of a greasy nature have been proposed for the purpose of rendering the attachment of these marine growths difficult, and of securing a gradual washing of the bottom when the ship is under weigh. Many others have been suggested having for their common object the poisoning or destruction of these lower forms of life. Sheets of glass, slabs of pottery, coatings of cement, enamelling, and many other plans for giving a smooth polished surface to the bottom, in order to prevent the adhesion of plants and animals, have been recommended, and in several instances tried, but not with much success. In fact, it would be difficult to point to any other subject which has been made the basis of so many schemes and patents, with so little practical advantage. Between 1861 and 1866 over a hundred plans were patented for preventing fouling, and in the subsequent period inventors have been quite as busy;

but no cure for fouling has yet been devised, the best compositions in use are only palliatives, and the question remains much in the same position as it did fifteen or twenty years ago.

A distinction must be made between *corrosion* and *fouling*. The former, with frequent inspection, cleaning, and painting of the outer bottom plating, can be made very slow; and this course is not merely advantageous in preserving the structure, but has the effect of reducing the tendency to fouling. Neglect of precautions against corrosion has the effect of making fouling more rapid. Some persons even go so far as to affirm that if all *rusting* were prevented on the bottoms of iron ships, they would be free from fouling; and that if a smooth, clean surface could be maintained, the plants and animals would not attach themselves. Some serious objections to this view may be urged; but it is needless to dwell upon them, since the conditions laid down can never be fulfilled in practice on the bottom of an iron ship, subject to blows, abrasions, and all the wear and tear of service, besides being almost constantly immersed in corrosive sea-water. All iron ships with unsheathed bottoms become foul in a comparatively short time; and cases are on record where a few months in tropical waters have sufficed to produce such an amount of fouling as to reduce their speed very considerably. Under ordinary conditions, if an iron ship can be docked and have her bottom cleaned and re-coated once or twice a year, all goes well; but longer periods afloat induce an objectionable amount of fouling.

Hence it is that vessels intended for cruisers in the Royal Navy, as well as special vessels in the mercantile marine, intended to keep the sea for long periods and to maintain their speed, have been either constructed on the composite system, or else had their iron hulls sheathed over with wood planking and covered with some metallic sheathing, such as copper, Muntz metal, or zinc. The clippers which were formerly employed in the China tea-trade, and whose annual races home attracted so much notice, were built on the composite system, resembling iron ships in all respects except that they had wood planking, keels, stems, and stemposts, and had their bottoms copper-sheathed. These vessels could lie in the Chinese ports unharmed, under conditions which produced very objectionable fouling in iron ships. In the Royal Navy at the present time the composite system of construction is applied to vessels up to the size of corvettes; the outside planking being worked in two thicknesses and the bottoms copper-sheathed. For larger and swifter cruisers, such as the *Volage* and *Inconstant*

classes, the use of an iron skin becomes a necessity in connection with the provision of structural strength; and in most of these vessels copper sheathing has been adopted, two thicknesses of wood planking being interposed between the sheathing and the iron hull. Three of the ironclads of the Royal Navy, the *Swiftsure*, *Triumph*, and *Neptune*, have also been built on a similar plan. It has now (1882) been thoroughly tested during twelve or thirteen years, and has proved satisfactory; but it involves some special dangers, and it is a very expensive method of construction, so that endeavours have been made to substitute zinc for copper, and one thickness of wood for the two formerly employed. The ironclads *Audacious* and *Temeraire* have been thus sheathed, and the earliest experiments proved sufficiently successful to procure further trials of zinc sheathing in two or three other vessels, some of which are now on service.

The anti-fouling properties of copper sheathing are due to the fact that the action of sea-water upon its surface produces oxychlorides and other salts which are readily soluble, and do not adhere strongly to the uncorroded copper beneath. Hence the salts, instead of forming incrustations, are continually being washed off or dissolved away, leaving the sheathing with a smooth, clean surface, and preventing the attachment of plants or animals. Some chemists have attached importance also to the poisonous character of the salts of copper in preventing fouling; but the foregoing is undoubtedly the more important feature, and is commonly termed "exfoliation" of the copper. The rate at which this wasting of the copper proceeds varies greatly under different circumstances, and with different descriptions of copper; and formerly this subject received much attention, the aim being to secure the minimum rate of wearing consistent with the retention of anti-fouling properties. For this purpose Sir Humphry Davy suggested to the Admiralty the use of "protectors," formed of iron, zinc, or some metal electro-positive to copper. When these protectors were put into metallic connection with the copper sheathing and immersed, galvanic action resulted, the protectors were worn away, and the rate of wearing of the copper was decreased in proportion to the ratio of the surface of the protectors to the surface of the sheathing. When the protector had about $\frac{1}{100}$ of the surface of the sheathing, there was no wasting of the copper: with a smaller proportionate surface of the protectors the copper wasted somewhat; but even when the protectors had an area only $\frac{1}{1000}$ part that of the sheathing, there was proved to be a sensible diminution in the rate of wear-

ing. The limits of protection from fouling appeared to be reached when the surface of the protectors equalled $\frac{1}{150}$ part of the surface of the sheathing. After experience on actual ships it was found, however, that preservation of the copper by this means led to rapid fouling, and the plan was abandoned. Nor has any substitute been since found; the practice being to exercise great care in the manufacture of the copper, and to regard its wasting as the price paid for preventing fouling. Muntz metal—an alloy of copper and zinc in the proportions of about 3 to 2—has been used largely as a substitute for copper, especially in the ships of the mercantile marine, and appears to answer fairly well, being, of course, much cheaper than copper. Such alloys are supposed by some persons to have the advantage of not producing powerful galvanic action upon iron immersed in sea-water and metallically connected with them; but this property has not been definitely established. On the other hand, it appears that, after being long immersed, the alloy tends to alter in composition. Muntz metal sheets have been found to become brittle after being some time in use; and the explanation given is that, the zinc being electro-positive to the copper, galvanic action is established between the two metals in the alloy, and part of the zinc removed. Muntz metal bolts have also been found to perish through galvanic action, under certain circumstances, when immersed in sea-water. The introduction of a third metal, such as tin, appears to prevent this objectionable change, even when it is present in very small quantities.

In the Royal Navy an alloy known as “Naval Brass” is now used instead of Muntz metal for securities in gun-metal castings, or in connection with copper sheathing, under water. This alloy consists of 62 per cent. of copper, 37 per cent. of zinc, and 1 per cent. of tin. It answers admirably for bolts; and trials have been made with it rolled into sheets and plates of a thickness suitable for the bottoms of ships. As regards strength and ductility the trials were satisfactory; but difficulties arose in connection with the riveting and watertight work on the thicker plates. The great expense of naval brass sheets, as compared with iron or steel, would prevent their extensive use in ship-work apart from other considerations; but in certain special circumstances their use might have been permissible had the trials proved wholly satisfactory. In fact somewhat similar alloys have been used for the construction of a few torpedo boats.

Zinc is another material largely used for sheathing the bottoms of wood ships. When immersed in sea-water, the salts

formed on the surface of a zinc sheet are very much more adherent to the uncorroded zinc than are the corresponding salts of copper, and are comparatively insoluble—or perhaps, we should say, are slowly soluble—by ordinary sea-water. Hence it appears that a coating of oxychloride of zinc, &c., is likely to form on the sheathing, not being washed away or removed like that on copper; and consequently zinc does not possess such good anti-fouling properties as copper, nor present such a smooth surface. It lasts for a considerable time under ordinary conditions. In some waters, however, and those of the tropics especially, zinc sheathing has been found to perish very quickly, owing probably to such a composition of the water as favoured the rapid solution of the salts formed on the surface, the exposure of the uncorroded zinc, its rapid oxidation, and so on. Sir John Hay records that, in the *Trinculo*, one commission on the African coast sufficed to strip the bottom of zinc and leave the wood exposed, fouling of course ensuing. Other cases are reported where zinc sheets $\frac{1}{8}$ inch thick have, under exceptional conditions, been worn through in the course of twelve months.

Under ordinary conditions, zinc sheathing is much more durable: in fact, to increase its anti-fouling qualities, it is often put into communication with some metal, such as iron, which is electro-negative to itself, in order that the galvanic action which is produced may have the result of keeping the surface of the zinc freer from incrustations to which marine plants and animals can adhere. Apart from this, it may be interesting to give the relative losses sustained by copper, zinc, Muntz metal, iron, and steel, when suspended in the sea for purposes of experiment by Dr. Calvert and Mr. Johnson.*

Metals.	Loss of Weight per Month on each Square Foot of Surface.	
	In a Vessel of Sea-water.	In the Sea.
	lb.	lb.
Copper	0·0027	0·0061
Muntz metal	0·0015	—
Zinc	0·0012	0·0070
Iron	0·0056	0·0204
Steel	0·0060	0·0216

* See the *Transactions* of the Literary and Philosophical Society of Manchester for 1865, quoted at page

199 of *Shipbuilding, Theoretical and Practical*.

These results are open to some doubt when applied as units in estimating the probable loss occurring during long periods of immersion in sea-water of various qualities; but they are valuable for purposes of comparison between the metals, and between the case of immersion in a vessel of sea-water and in the sea itself, where there are many causes tending to remove the salts formed on the surfaces. The greatly different rates of wearing in different seas is a matter of common experience; and the experiments made by the late Mr. R. Mallet, F.R.S., furnish some valuable information on this head.* Iron boiler plates which lost from 0·007 lb. to 0·009 lb. per square foot per month in *clear* sea-water, lost about twice as much in foul sea-water. With steel, very similar results were obtained.

Wood ships are protected from fouling by nailing the metal sheathing directly upon the wood planking; iron ships cannot be protected in quite so simple a way, the metal sheathing having to be attached in a manner dependent upon its position in the galvanic scale relatively to iron, and upon its anti fouling properties. Copper sheathing, for example, may produce serious galvanic action upon the iron hull, or portions of the hull, if there is intimate metallic connection between the sheathing and the iron; and even a very indirect metallic connection will suffice to produce some action. Muntz metal, again, is electro-negative to iron, and therefore requires to be insulated. Zinc, on the contrary, being electro-positive to iron, need not be insulated from it; but since the rate of wasting required to prevent fouling of the zinc is practically governed by the amount of galvanic action set up on its surface by the iron, considerable care is needed in adjusting the relative surfaces of the two materials subjected to galvanic action. A brief description will suffice to show what has been done in practice to overcome these various difficulties.

Ships of the Royal Navy built of iron, or on the composite principle, and copper-sheathed, have two thicknesses of wood planking interposed between the copper and the iron portions of the hull. The inner thickness is bolted to the skin-plating or to the iron frames with galvanised iron bolts; the outer thickness is bolted to the inner with malleable yellow metal bolts, the bolts not being allowed to come into contact with the iron of the hull, nor with the bolts of the inner thickness. Wood stems and stern-

* See reports of British Association, 1841-43; also vol. xiii. of the *Transactions* of the Institution of Naval Architects.

posts are fitted in many of the composite vessels; but in the swift cruisers and ironclads brass stems and sternposts are employed. The copper sheathing is not brought into contact with the metal stems or sternposts, nor with the metal kingston-valves, &c., passing through the bottom; and by these means it is endeavoured to insulate the copper from the iron hull. Doubts have been expressed as to the sufficiency of these precautions, it being supposed that there must be some metallic connection between the hull and the copper, resulting in corrosion of the iron. It will suffice to say in reply that the precautions taken at least prevent any powerful local action, such as might otherwise take place in the neighbourhood of the fastenings. In fact, after twelve years' experience with the sheathed ships of the *Inconstant* and *Volage* classes, including service on very distant stations and in tropical waters, no signs of serious galvanic action or corrosion have been discovered upon careful examination. Further, the copper sheathing has well maintained its anti-fouling properties, which it could scarcely have done if it were causing much galvanic action on the iron hull.

One special danger is necessarily incurred by such ships, and ought not to be passed over. Any damage to the bottom which stripped off the bottom planking and exposed a portion of the iron skin, might place that portion of the skin within the influence of powerful galvanic action: for it would be immersed in the same sea-water as the copper sheathing, be almost certainly in metallic connection therewith, and have concentrated upon its comparatively small area the action of the very large surface of copper sheathing. The result might be very rapid corrosion of the iron skin, and possibly its perforation by holes. Such an accident, capable of stripping off wood planking 5 or 6 inches thick, firmly attached to an iron hull, must of course be exceptional in severity, and of very rare occurrence. No such case has yet occurred: but the Admiralty Regulations provide against the contingency, the commanding officer being ordered to have his ship examined and repaired with the least possible delay.

Allusion has already been made to the dangers attendant on galvanic action of the kind described, where some metal valve or pipe, connected with the iron skin and immersed in the same sea or bilge water, has produced local corrosion of a very serious and rapid character. The case of her Majesty's store-ship *Supply* illustrated this, and in the *Megara* also there was reason to believe that galvanic action had taken place.* To prevent such

* See the report of the Royal Commission on the loss of the *Megara*.

galvanic action on the iron skin, very stringent rules are, as was shown above, laid down for the guidance of officers charged with the construction or care of iron ships in the Royal Navy.

To illustrate the greatly increased rate of corrosion of iron, incidental to galvanic action, a few examples may be taken from the results of the experiments recorded by Mr. Mallet. An iron plate immersed *alone* in clear sea-water was found to lose during a certain period a quantity which we will denote by unity: it was then immersed for an equal time in clear sea-water with an equal surface of the following metals electro-negative to it, and the corrosion increased as follows:—

Experiments.	Relative Corrosion.
Iron plate in contact with copper	4·96
” ” ” ” brass	3·43
” ” ” ” gun-metal	6·53
” ” ” ” tin	8·65
” ” ” ” lead	5·55

Other laboratory experiments, made on an extensive scale, have given different results for the relative intensities of the action of the various metals on the iron; but they fully confirm the fact that a greatly increased rate of corrosion results from galvanic action. The first two materials, copper and brass, are those of which the shipbuilder has need to take most heed in arranging the sheathing or fittings of iron ships.

The increased cost of copper-sheathed iron ships is considerable, and in composite ships of the merchant fleet the use of the two thicknesses of planking was by no means common, doubtless because of the additional outlay required. With a single thickness of planking there is, of course, much greater risk of galvanic action, but in merchant ships Muntz-metal sheathing is commonly used, and its action on iron is supposed to be comparatively feeble. It has been asserted that no great difficulty would be encountered in making sheathing of such an alloy of copper and zinc as would be electro-neutral to iron, and have no galvanic action upon it when immersed in sea-water. We are unaware, however, that any such sheathing has been tried, and nothing but experience could show whether or not it would be effective against fouling. Zinc sheathing has, however, been substituted for copper in many recent ships of the Royal Navy, and if it had proved an efficient anti-fouling material, it would have been much less costly than copper, and could under no circumstances produce anything but beneficial action on the iron hull.

Various plans have been tried for attaching zinc sheathing to iron hulls; that commonly used in the Royal Navy is as follows:—A single thickness of planks (3-inch to 4-inch) is bolted outside the skin plating; to this the zinc sheets are nailed: the strakes of planking are not caulked, but the water which finds its way under the sheathing can pass freely through the seams to the iron skin. Iron stems and stern-posts are employed; and by various means a certain amount of metallic connection is made between the zinc and the iron hull, such connection, as explained previously, being desirable in order to keep the surface of the zinc freer from incrustation. Hitherto the practical difficulty has been to adjust the relative amount of the surfaces of iron and zinc, contributing to galvanic action on the latter, in such a manner as to prevent too rapid or too local wearing of the zinc, without interfering with its anti-fouling properties. In fact, the present condition of this question bears a considerable resemblance to that previously existing, when iron protectors were under trial with copper sheathing. On wood ships, zinc usually lasts for a considerable time, but is not very successful in preventing fouling: there it has but little metallic contact to produce galvanic action. On some merchant ships where the zinc has been laid almost directly upon the iron skin, with felt or some similar material interposed, its rate of wear has been so quickened that a single voyage has sufficed to destroy it. Between these two conditions must lie the practically useful method of attachment, and upon this experience with actual ships can alone decide. There is little hope that zinc can ever be made to equal copper in its anti-fouling qualities and smoothness of surface. So far as experience has gone it appears that a short period of immersion of zinc in sea-water produces considerable roughness of surface; and that an unpainted zinc bottom is likely to be much rougher soon after a ship is undocked than a clean-painted iron bottom. This feature in zinc sheathing exercises a sensible effect upon the speed-trials of ships; and it is customary in the zinc-sheathed ships of the Royal Navy to paint the bottoms, when the ships are docked, with some anti-fouling composition. But, while this comparative roughness tells against unpainted zinc sheathing in the periods immediately succeeding undocking, the fouling which succeeds is not nearly so serious at the end of a considerable time afloat as it usually is in iron ships. The great extensions of dock accommodations in all parts of the world make the use of any kind of sheathing unnecessary on iron ships of the mercantile marine; and the annual outlay on docking, cleaning and recoat-

ing is very moderate, even in large ships. For ships of war, which frequently have to keep the sea for much longer periods than merchant ships, zinc sheathing may be of service; but, although it reduces the cost of construction and removes some risks, it is not to be compared with copper-sheathing in its anti-fouling qualities. The inferiority of zinc to copper has always been recognised, and experience appears to show that for ships having high speeds under steam, or designed for cruising under sail, the disadvantages of zinc are sufficient to make it worth while to incur the greatest first cost of copper, and the possible risks incidental to grounding or collision.

Many persons who admit the superiority of iron to wood hulls in vessels of the mercantile marine question the desirability of using iron hulls for war-ships, unless they are ironclads. Un-armoured fighting ships, it is still urged, should be wood-built. A few remarks on this matter will not, therefore, be out of place.

More than forty years ago two iron steamers, the *Nemesis* and *Phlegethon*, were built for the East India Company, and successfully employed in the Chinese war of 1842. A few years later several iron frigates were ordered to be built for the Royal Navy; but these were ultimately converted into troopships, the *Simoom* and *Megara* amongst the number. This change was made after a series of experiments had been conducted with targets representing the sides of the *Simoom* and other vessels. These vessels had strong transverse frames spaced only 1 foot apart; and it was found that a very serious amount of splintering took place from the side of the ship first struck, while the opposite side was considerably damaged. On the whole, it was considered that the damage done by solid and hollow spherical shot to these iron ships was likely to prove of a more destructive character to the crews than the corresponding damage in a wood ship. But it was remarked that iron plating above $\frac{1}{2}$ inch in thickness sufficed to break up the shell and hollow shot from the heaviest guns then mounted in ships. This feature was undoubtedly a very great advantage of the iron sides, as compared with wood; and the destruction of the Turkish fleet at Sinope, as well as the experience with our own ships during the Crimean War, proved how great was the danger of wood hulls exposed to the fire of shell guns. On the whole, however, the decision arrived at from the trials in the *Simoom* target still holds good; and from that time to this no fighting ship of the Royal Navy has been built with uncovered iron sides, and closely spaced frames, in wake of the gun decks.

Iron hulls were confined to armoured ships until the construction of the swift cruiser class, of which the *Inconstant* was the earliest example. In order to secure the requisite structural strength, an iron hull was then considered necessary; but the transverse frames were widely spaced, and the shattering effect of projectiles was still further reduced by covering the thin iron plating with wood planking. The *Simoom* target experiments had shown that wood so applied reduced splintering and damage: subsequent experiments at Shoeburyness, with targets representing respectively the sides of a wood frigate and those of a swift cruiser, have confirmed the soundness of this view, even when the vessels are exposed to the fire of heavier guns than those in use over thirty years ago.

There are a few classes of unarmoured war-ships in which guns are fought behind thin uncovered iron or steel plating; but these guns are mounted for the most part on the upper deck "in the open." As examples, reference may be made to despatch vessels such as the *Iris*, or to cruisers such as the *Leander* class in the Royal Navy: the coast-defence gunboats of the *Comet* class also come under this category. Before and abaft the central batteries or citadels of ironclad ships, there are frequently considerable portions of the top sides formed by thin uncovered iron plating; but in action these unprotected spaces would not be occupied by men, and splintering would not be productive of serious consequences. There are, however, a few cases where guns are fought under cover of a deck, and behind thin plating unprotected by wood planking, as for example in the belted ships of the *Nelson* class in the Royal Navy; very special arrangements being made to prevent splintering. The plating is of steel, about twice the thickness of an ordinary iron side: there are no numerous vertical frames behind it to be shattered; and any damage that may be done is restricted to a limited space by means of "traverse bulkheads" which are splinter-proof. On the whole, therefore, it may be safely asserted that the unarmoured or partially protected iron fighting-ships of the Royal Navy are not open to the objections which were fairly urged against the *Simoom* and her consorts more than thirty years ago, and which apply with considerable force to iron-built merchant ships of the present day, unless they carry guns, only on the upper deck, and are fortified by "coal-protection."

Having reviewed the relative advantages of wood and iron as materials for shipbuilding, we propose, before concluding this chapter, to glance at the advantages to be gained by the substitution of steel for iron.

Prior to 1870 steel was used to a very limited extent, and chiefly in cases where extreme lightness of hull or shallowness of draught was essential. Taking the twenty years from 1850 to 1870 it appears that over 3,600,000 tons of iron ships were built for the British mercantile marine, while only 27,000 tons of steel ships were constructed; and from 1866 to 1875 only three small ships were built of steel in the United Kingdom. In the Royal Navy steel was used continuously from 1864 to 1875 for certain portions of the internal framing of iron ships and armoured vessels; but always under special precautions. Early in 1873, however, the French began to use the so-called "mild steel" or "ingot-iron" in the construction of war-ships; the Admiralty followed this example in 1875, ordering two despatch vessels to be constructed wholly of steel; and in 1877 the use of the same material in the mercantile marine, received the sanction of Lloyd's Register. Since 1875 the progress made in the use of mild steel has been extremely rapid. In the Royal Navy it has almost superseded iron, which is used for minor portions of the structure simply on account of its cheapness. In the mercantile marine great advances have been made, as the following figures will show. In 1878, 4500 tons of steel shipping were classed at Lloyd's; in 1879, 16,000 tons; in 1880, 35,400 tons; and in 1881, 41,400 tons. At the end of 1880, thirty-six steel vessels were under construction, having an aggregate tonnage of 114,000 tons. During the year 1881, 71,500 tons of steel ships were built and registered in the United Kingdom; and at the close of that year 188,600 tons of steel ships were under construction.* Some of the great steamship companies have already decided to use steel exclusively, and the example thus set will probably be followed extensively.

This rapid progress in steel shipbuilding must be attributed mainly to the introduction of "mild steel"; a material which is in no respect inferior to iron, which can equally well withstand all the operations of the shipyard, is very ductile and malleable, about 25 to 30 per cent. stronger, under tensile strain, than the best iron ship-plates, and only 2 to 2 $\frac{1}{4}$ per cent. heavier for equal volumes. Most of the varieties of steel used in shipbuilding before 1873 had the serious disadvantage of lacking uniformity in strength, ductility and malleability. If these serious faults were avoided by exceptional care in manufacture, the price of

* For many of these figures the Author is indebted to Mr. Waymouth, Secretary to Lloyd's Register.

the material became so high as to be practically prohibitive except in very special cases. Not unfrequently steel plates made under similar conditions, and presumably of the same quality, displayed, when tested, singular differences in their qualities. Consequently the shipbuilder and shipowner had not the same assurance of safety with steel as was possible with iron. Moreover, it was found with these earlier descriptions of steel that much greater care was required in the manipulation during the various processes of building—such as punching, bending, forging and riveting—than was needed in the corresponding operations on iron. These steels were much stronger than iron, having tensile strengths from 30 to 50 tons per square inch, as against 17 to 22 tons for good iron. And on account of their greater strength these varieties of steel were used in exceptional cases notwithstanding their known faults and greater cost. Vessels for river service like that illustrated in Figs. 105 and 106, pages 361-2, steamers for the Channel service, blockade-runners, and other classes in which lightness of hull was the most important condition to be fulfilled, were all built of steel. It is but proper to add of these early steel ships that most of them performed their work well, and some of them have displayed remarkable durability under very trying conditions of service. The failures and difficulties to which allusion has been made were chiefly experienced in the shipyard.

Mild steel is free from most of the defects mentioned above. It can be produced in large quantities, of uniform quality, and at a cost which does not compare unfavourably with that of good wrought iron. The tensile strength of the material now in common use is not so high as that of earlier varieties of steel, but the ductility is much greater. From 26 to 32 tons per square inch represent the limits of tensile strength not commonly exceeded; the elongation of a sample before fracture under tensile strain frequently reaches 25 to 30 per cent. in a length of 8 inches. But there is reason to believe that still higher tensile strength, up to 35 or 40 tons per square inch, may be obtained, if desired, in association with excellent working qualities, and without that degree of hardness which would make the steel take a "temper" when heated to a low cherry-red and plunged into water having a temperature of 82° Fahrenheit.

Another property of mild steel deserving notice is the practical equality of the strength and ductility of samples cut lengthwise or breadthwise from plates. With iron, as is well known, the samples cut lengthwise would have about one-fifth or one-sixth greater tensile strength and much more ductility than the cross-

wise samples from the same plate; and care has to be taken in many parts of iron ships to adjust the plates and butt-straps in the manner most favourable to this inequality of strength. Closely connected with this uniformity of strength and great ductility is the capacity of mild steel to bear rough usage. Under percussive strains—produced by the blows of steam-hammers, falling weights, the explosion of gun-cotton, &c.—mild steel has been proved greatly superior to the best wrought iron. In cases of collision, grounding, &c., ships built of mild steel have had their plating bulged and bent without cracking under circumstances which would have broken through less ductile iron plates. And in the shipyard much work can be done on steel cold, which could only be done on iron after heating. One most important feature in the working qualities of mild steel should be mentioned. It should not be subjected to percussive strains or shocks when at a “blue-heat”—say from 430° to 580° Fahr., at which heat its ductility is at a minimum. Very little care is needed, however, to avoid this dangerous temperature.

The “elastic limit” for mild steel (see the remarks in page 386) has been found to vary from about 55 to nearly 80 per cent. of the ultimate strength; and 60 per cent. is probably a fair average value. For superior qualities of iron about the same percentage of the ultimate strength probably represents the elastic limit. Hence it follows that, notwithstanding its greater ductility, mild steel can bear “working strains” having as great a ratio to the ultimate strength, as superior wrought iron can bear. This is an important matter: mild steel may be trusted with working loads from 25 to 30 per cent. greater than superior iron.

Since steel loses nothing as compared with iron in the variety of the forms in which it is produced, the efficiency of its connections, and its adaptability to the combinations required in the structures of ships, its greater strength makes it possible to use thinner and lighter plates and bars than would be needed with iron, in order to secure a certain strength. The reductions made in thickness are influenced by various considerations: such, for example, as the tensile strength of the steel used, the character of the framing which supports the plating and assists it against buckling, the requirements of local strength, or considerations of durability. In order that the full advantages of the greater tensile strength of the steel may be realised, it is obviously necessary to take proper precautions against local failure of the reduced thicknesses of plates and bars. If, on the contrary, the system of framing usual with iron is perpetuated with steel, it

may be necessary to limit the reduction in thickness in order to secure sufficient rigidity between the supports. In the majority of the earlier steel ships the frames were transverse, and spaced much as they would have been in iron ships. The reductions in scantlings varied with the character of the steel used: in some cases these reductions were about *one-fourth* of the scantlings used in iron, in others *one-third*, and in a few cases as much as *one-half*. These reductions were accompanied, of course, by proportionate savings in weights of the hull and additions to the carrying power.

With mild steel such as is now used the reductions in scantlings vary from 15 to 20 per cent. of the scantlings usual in iron. Lloyd's Rules permit a reduction of 20 per cent. on the plates and frames of a ship built of mild steel having a tensile strength varying from 27 to 31 tons per square inch. This tensile strength is at least 35 to 40 per cent. greater than that of good iron, but the limit of reduction appears to have been fixed with reference to the rigidity of steel and iron plates, when supported at intervals corresponding to the ordinary frame-spaces in ships built on the transverse system. The saving in weight of hull does not amount to 20 per cent., however; because in that weight are included a considerable weight of forgings, woodwork and fittings, not affected by the reduction in scantlings. Moreover, as iron is cheaper than mild steel, it is still commonly used for minor portions in the internal works in steel ships—such as divisional bulkheads, platforms, &c., contributing very little to the general structural strength. Making allowance for these restrictions, it is stated by the best authorities that in ships classed at Lloyd's, the use of steel effects a saving from 13 to 15 per cent. on the weight of iron which would be used in a ship of the same dimensions. This reduction in the weight of the hull, and consequent increase in the carrying power, is always of value in a merchant ship; although its relative importance may vary considerably in ships of different types, engaged in different trades, and performing voyages of different lengths and at various speeds. It is not possible here to discuss the economical advantages of steel ships at any length, nor to compare their first costs and subsequent earnings with those of iron ships. But an illustration or two may be of interest.* As the first, take a cargo and passenger

* On this subject see a valuable Paper by Mr. W. Denny in the *Proceedings* of the Iron and Steel Institute for 1881, from which we borrow some

of the facts given above. See also a Paper by Mr. Price in the *Proceedings* of the Institution of Mechanical Engineers for 1881.

steamer for the Eastern trade, 310 feet long, 39 feet broad, and 27·5 feet deep. If built of iron or of steel, the weights would compare somewhat as follows :

	Iron Ship.	Steel Ship.
	Tons.	Tons.
Iron or steel in the hull	1360	1170
Other weights of hull	600	600
Total weight of hull	1960	1770
Weight of machinery	260	260
	2220	2030
Carrying power (coals and cargo)	3360	3550
Displacement	5580	5580

This transfer of 190 tons from the hull to the carrying power might be of very considerable importance on a long voyage where a large coal-stowage was necessary; and on any voyage the additional freight must be of value. To the subject of relative first cost we shall refer hereafter.

As a second example we may compare two fast passenger steamers of about 8500 tons displacement when fully laden. Their weights may be distributed somewhat as follows if they are supposed to be employed on the Australian line *viâ* the Cape of Good Hope:—

	Iron Ship.	Steel Ship.
	Tons.	Tons.
Iron or steel in the hull	2600	2250
Other weights of hull	1100	1100
Total weight of hull	3700	3350
Weight of machinery	1100	1100
„ coal (maximum)	2500	2500
„ cargo (about)	1200	1550
Displacement	8500	8500

That is to say the use of steel would increase the cargo capacity by about 30 per cent. It will be understood, of course, that these figures must be treated as approximate only.

The use of steel in war-ships has been productive of similar advantage to the carrying power. Previously to the general use of steel, very superior qualities of iron were used, and the scantlings were reduced as much as possible, consistently with

strength, in order to diminish the weight of hulls. Many of the internal portions of the structure had been made as thin in iron as was consistent with durability, and here no reductions were possible when steel was used. Moreover in war-ships a large portion of the weight of hull goes into elaborate fittings, which are indispensable and unaffected by the change from iron to steel. Notwithstanding these limitations, very substantial gains have been obtained from the use of steel. One example must suffice. It has been estimated that in one of the first steel-built ships of the Royal Navy the use of steel lightened the hull by 175 tons—12 per cent. on the total weight of the hull, including the fittings—and increased the weight of coal carried by nearly one-third, as compared with what it would have been in an iron-built ship of the same dimensions and speed.

Turning to the relative cost of iron and mild steel a few facts may be stated:—In 1877 steel was about twice as costly as the iron in common use; but it is important to notice that the sources of supply were then comparatively few. Moreover the iron used in mercantile shipbuilding has never been subjected to thorough and severe testing such as is universally applied to steel, which fact necessarily tends to increase the price of steel. For ships of the Royal Navy equally searching tests have been applied to both materials; and under these conditions a very short time elapsed before mild steel could be procured at a lower price than superior iron. The same thing holds good in the French navy. And in the mercantile marine as the sources of supply for mild steel have been multiplied, and the manufacture has been more thoroughly understood, its price has steadily fallen relatively to iron. In 1880 steel seems to have been about 50 per cent. dearer than iron; and at the time of writing (the close of 1881) a still closer approach to equality in price has been made. Some persons consider that steel will ultimately be as cheap as iron of ordinary ship quality; but this seems doubtful at present, and every one agrees that to maintain the high standard of excellence which has been reached with steel, a continuance of the established system of testing is necessary. Apart from these facts, however, it may be assumed that even as prices have stood during the last four or five years, steel ships have proved themselves economically superior to iron ships in many trades; for, if this were not true, the shipowners who have had experience with steel ships would not continue to add to their number.

Reduced thicknesses of plates and bars in steel ships necessitate great care to prevent corrosion. Experience with steel ships is

at present so limited that it is not possible to form a definite opinion respecting the relative rates of corrosion of iron and steel when immersed in sea-water. So far as experience has gone it appears that with proper precautions in cleaning and coating, steel does not corrode more rapidly than iron under the ordinary conditions of service. Many of the early steel ships with very thin plating have continued at work for twenty years; and although they are not constructed of mild steel their great durability is noteworthy. In one particular there is reason to suppose that mild steel requires special care under certain circumstances. The manufacturer's "scale" adheres much more strongly to steel plates than to iron, and from experiments made for the Admiralty, as well as from experience on actual ships, it seems that if this scale is not thoroughly removed it may set up galvanic action on adjacent parts of the surface which are free from scale when the plates are immersed in sea-water. Merchant ships are usually built in the open air, and in them the scaling is often performed without much difficulty. Steel ships of the Royal Navy are usually built under cover, and after many experiments it has been found preferable to remove the scale by immersing the plates in a bath of dilute hydrochloric acid, and subsequently washing them with water, before they are worked into the ship. In this manner at small expense clean surfaces can be obtained, and pitting or rapid local corrosion from the action of the scale may be prevented.

As to fouling, steel ships appear to be no better off than iron ships, requiring to be docked and coated just as frequently.

On a review of the facts which have been stated above, it can scarcely be doubted that the rapid development of steel ship-building in recent years is but the prelude to the general substitution of steel for iron. That substitution has been made in the Royal Navy, and very nearly completed in the French navy; similar changes will doubtless be made also in merchant ships, and will be hastened if improved metallurgical processes enable manufacturers to reduce the price of steel. It may well happen also that mild steel may ultimately be displaced by a stronger material having equally good qualities as regards ductility and workability. If manufacturers can succeed in producing such steel at moderate cost, shipbuilders will avail themselves of the opportunity to advance still further the combination of strength with lightness.

CHAPTER XI.

THE RESISTANCE OF SHIPS.

No branch of the theory of naval architecture has a richer literature than that which forms the subject of this chapter. It would be a formidable task merely to enumerate the names of eminent mathematicians and experimentalists who have endeavoured to discover the laws of the resistance which water offers to the progress of ships; and still more formidable would be any attempt to describe the very various theories that have been devised. Again and again has the discovery been announced of the "form of least resistance," but none of these has largely influenced the practical work of designing ships, nor can any be regarded as resting on a thoroughly scientific basis. In fact, a century and a half of almost continuous inquiry has firmly established the conviction that the problem is one which pure theory can never be expected to solve.

Although earlier theories of resistance are now discarded, and the present state of knowledge on the subject is confessedly imperfect, great advances have been made within the last half-century, and most valuable experimental data have been collected. The modern or "stream-line" theory of resistance may now be regarded as firmly established. Many eminent English mathematicians have been concerned in the introduction and development of this theory, as well as in the conduct of the experiments by which it has been put to the test. Of these, however, two only need be named. The late Professor Rankine did much to practically apply the theory to calculations for the resistances and speeds of ships; and the broad generalisations which we owe to him have served ever since as guides to later investigators.* The late Mr. W. Froude is the second worker in

* See div. i. chap. v. of *Shipbuilding, Theoretical and Practical*, edited by Professor Rankine.

this field of inquiry, whose labours deserve especial mention. The experiments which for some years he conducted for the Admiralty are beyond all comparison with any that have gone before them; the greatest value attaches to the small portions of his results which have yet been published; and should the inquiry be completed on the lines laid down by him, and the results fully discussed, naval architects will be in possession of a mass of facts which cannot but prove highly advantageous to the designs of future ships. These experiments of Mr. Froude have been carried on upon the basis of the stream-line theory of resistance, and have fully confirmed its soundness. In addition, however, to this service, Mr. Froude did much to elucidate and popularise the theory. His clear and masterly sketches of its main features are well worthy of careful study;* and they have the advantage of being almost entirely free from mathematics, so that the general reader can readily follow the reasoning and the experiments by which it is supported. In attempting, as we now propose to do, a brief outline of this modern theory, we gladly acknowledge our indebtedness to both Professor Rankine and Mr. Froude.

A few prefatory remarks are necessary in explanation of terms that will be frequently employed. Water is not, what is termed, a *perfect* fluid; its particles do not move past one another with absolute freedom, but exercise a certain amount of rubbing or friction upon one another, and upon any solid body past which they move. Suppose a thin board with a plane surface to be immersed in water and moved end-on, or edgewise, it will experience what is termed *frictional* resistance from the water with which its surface comes into contact. The amount of this frictional resistance will depend upon the area and the length of the plane, as well as the degree of roughness of its surface and the speed of its motion. If this plane is moved in a direction at right angles to its surface, it encounters quite a different kind of resistance, termed *direct* or sometimes *head* resistance; this depends upon the area of the plane and the speed of its motion. Should the plane be moved obliquely, instead of at right angles to its surface, the resistance may be regarded as a compound of direct and frictional resistance. Supposing either direct or oblique motion to take place, the plane would leave an eddying "wake" behind it, as indicated somewhat roughly in Fig. 117,

* See *British Association Reports* for 1875, and vols. xv. to xxi. of the *Transactions* of the Institution of Naval Architects.

and the motion thus created amongst the particles constitutes a very important element in their resistance to the passage of the plane. If the plane is not wholly immersed, or if its upper edge is near the surface, and it is moved directly or obliquely, it will heap up water in front as it advances, and create waves which will move away into the surrounding water as they are formed, and will be succeeded by others. Such wave-making requires the expenditure of power, and constitutes a virtual increase to the resistance. If the plane were immersed very deeply, it would create little or no surface disturbance, and, therefore, require less force to propel it at a certain speed than would a plane of equal immersed area moving at the surface with a portion situated above that surface. If there were no surface disturbance, the resistance would be practically independent of the depth of immersion. This statement is directly opposed to the opinion frequently entertained; which confuses the greater *hydrostatical* pressure on the plane, due to its deeper immersion, with the dynamical conditions incidental to motion. It may, therefore, be desirable to add a brief explanation.

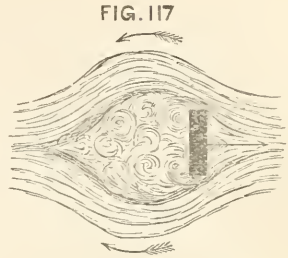

Supposing a deeply immersed plane to be at rest, then the pressures on its front and back surfaces would clearly balance one another at any depth. When this plane is moved ahead at a uniform speed, it has at each instant to impart a certain amount of motion to the water disturbed by its passage; but the momentum thus produced is not influenced by the hydrostatical pressures on the plane, corresponding to the depth of its immersion. Water is practically incompressible; apart from surface disturbance, the quantity of water, and therefore the weight, set in motion by the plane, will be nearly constant for all depths, at any assigned speed. In other words, if there be no surface disturbance, the resistance at any speed is independent of the depth. This is equally true of direct, oblique and frictional resistance, and has been established experimentally. For example, Colonel Beaufoy ascertained the resistances of a plane moving normally to itself, when submerged to depths of 3, 6 and 9 feet below the surface, and found them practically identical at all the depths. These experiments also served to establish the following very useful rule: The resistance per square foot of area sustained by a wholly submerged plane moving normally to itself through

sea-water at a uniform speed of 10 feet per second is 112 lbs.; and for other speeds the resistances vary as the squares of the speeds.

Beaufoy also endeavoured to determine the laws governing the resistance of a wholly submerged plane set at various angles to its line of motion. Prior to the test of experiment it had been assumed that such oblique resistance varied with the *square of the sine* of the angle made by the plane with its line of motion; so that for a given speed of advance, and an angle of obliquity α ,

$$\text{Oblique resistance} = \text{Direct resistance} \times \sin^2 \alpha.$$

Beaufoy's experiments proved this assumption to be incorrect, and, as the records are not now generally accessible, it may be well to summarise the results.

BEAUFOY'S EXPERIMENTS ON RESISTANCES OF SUBMERGED PLANE-SURFACES.

Angles of Plane with line of motion. . . .	90°	80°	70°	60°	50°	40°	30°	20°	10°
Sines of Angles .	1	·985	·940	·866	·766	·643	·5	·342	·174
(Sines) ² of Angles	1	·97	·88	·75	·587	·413	·25	·117	·03
Resistances . . .	1·00	·915	·845	·828	·722	·579	..	·321	·272

From this table it appears that up to angles of 50 to 60 degrees the resistance varies with a fair approach to agreement with variations in the sine of the angle multiplied by the direct resistance; and this is an approximate rule which is of considerable value in practice. The theoretically correct law connecting the direct and oblique resistances on the *front* of a plane surface has been determined by Lord Rayleigh, and is as follows:—Let P = the "direct resistance" experienced by the front surface of a plane when moving normally to itself at a certain speed; and P_1 the corresponding resistance when it is inclined at an angle α to the line of motion. Then

$$P_1 = \frac{2\pi \sin \alpha}{4 + \pi \sin \alpha} \cdot P = \frac{\sin \alpha}{\cdot637 + \cdot5 \sin \alpha} \cdot P.$$

This formula takes no account of the negative pressure on the back surface of the plane.

M. Joëssel of the French Navy has conducted a series of valuable experiments on the same subject and has deduced therefrom a formula similar in form but not identical with Lord Rayleigh's. It is as follows:—

$$P_1 = \frac{\sin \alpha}{\cdot39 + \cdot61 \sin \alpha} \cdot P,$$

but P_1 and P here stand for the *total* pressures on the front and back surfaces of the plane.

There is no necessity for making any comparison between the results obtainable from these two formulæ and Beaufoy's experiments, as the reader will have the means of making it; in practice the simpler rule above stated is generally followed.

Numerous experiments have been made to determine the frictional resistances of planes moved through water; the most recent as well as most valuable being those conducted by the late Mr. Froude for the Admiralty. Frictional resistance is measured by the momentum imparted to the water in a unit of time; this momentum being imparted, at each instant, to a current or "skin" of water which is then adjacent to the surface. This skin of water has a motion given to it in the direction of advance of the plane; while the particles within it move in frictional eddies. The extent to which the frictional resistance causes disturbance—that is to say the "thickness of the skin"—varies with the velocity and other circumstances of the motion. From instant to instant the frictional current thus created is left behind by the moving surface, and a "frictional wake" is formed which follows the surface. The forward motion of this wake is gradually communicated to larger masses of water, its velocity is consequently decreased, and finally it ceases to be perceptible. It need scarcely be repeated that the momentum imparted to the water in a unit of time by a plane moving at a given speed is independent of the depth of immersion and the corresponding hydrostatical pressure on the plane; it being understood that we may neglect any small variations in the density of the water produced by changes in that depth. The governing conditions of the frictional resistance are the area and length of the plane, its degree of roughness, and the speed of advance.

Passing from these general considerations to the results of experiments on actual plane surfaces, attention must be limited to those obtained by Mr. Froude, and summarised by him in the following tabular statement and prefatory remarks.

MR. FROUDE'S EXPERIMENTS ON SURFACE-FRICTION.

This table represents the resistances per square foot due to various lengths of surface, of various qualities, when moving with a standard speed of 600 feet per minute, accompanied by figures denoting the power of the speed to which the resistances, if calculated for other speeds, must be taken as approximately proportional.

Under the figure denoting the length of surface in each case, are three columns, A, B, C, which are referenced as follows:—

- A. Power of speed to which resistance is approximately proportional.
 B. Resistance in pounds per square foot of a surface the length of which is that specified in the heading—taken as the mean resistance for the whole length.
 C. Resistance per square foot on unit of surface, at the distance sternward from the cutwater specified in the heading.

Nature of Surface.	Length of surface, or distance from cutwater, in feet.											
	2 feet.			8 feet.			20 feet.			50 feet.		
	A.	B.	C.	A.	B.	C.	A.	B.	C.	A.	B.	C.
Varnish . . .	2·00	·41	·390	1·85	·325	·264	1·85	·278	·240	1·83	·250	·226
Paraffine . . .	1·95	·38	·370	1·94	·314	·260	1·93	·271	·237
Tinfoil . . .	2·16	·30	·295	1·99	·278	·263	1·90	·262	·244	1·83	·246	·232
Calico . . .	1·93	·87	·725	1·92	·626	·504	1·89	·531	·447	1·87	·474	·423
Fine sand . . .	2·00	·81	·690	2·00	·583	·450	2·00	·480	·384	2·06	·405	·337
Medium sand	2·00	·90	·730	2·00	·625	·488	2·00	·534	·465	2·00	·488	·456
Coarse sand .	2·00	1·10	·880	2·00	·714	·520	2·00	·588	·490

NOTE.—Beaufoy's experiments made in the Greenland Docks (1794-98) gave values of A between 1·7 and 1·8, closely agreeing in this respect with the later experiments of Mr. Froude.

From these experiments the following deductions have been made. First: that the law formerly assumed to hold is very nearly conformed to, the frictional resistance varying approximately as the *square of the velocity*, when the area, length and condition of the surface remain unchanged. Second: that the *length* of the surface sensibly affects the mean resistance per square foot of wetted surface; and especially when very short planes are compared with planes of 50 feet or upwards. For greater lengths than 50 feet it appears that the mean resistance per square foot of area remains nearly the same as for the plane 50 feet long. Mr. Froude explains this important experimental fact as follows:—"The portion of surface that goes first in the "line of motion, in experiencing resistance from the water, must "in turn communicate motion to the water in the direction in "which it is itself travelling; consequently the portion of the "surface which succeeds the first will be rubbing, not against "stationary water, but against water partially moving in its own "direction; and cannot, therefore, experience as much resistance "from it."

A third important deduction is the great increase in frictional resistance which results from a very slight difference in the apparent roughness of the surface. For instance, the frictional resistance of a surface of unbleached calico—not a very rough surface—was shown to be about double that of a varnished surface.

This varnished surface, it is interesting to note, gave results just equal to a surface coated with smooth paint, tallow, or compositions such as are commonly used on the bottoms of iron ships. The frictional resistance of such a surface moving at a speed of 600 feet per minute would be about $\frac{1}{4}$ lb. per square foot; which would give a frictional resistance of about 1 lb. per square foot of immersed surface for the clean bottoms of iron ships when moving at a speed of about 12·8 knots. This unit is worth noting.

The foregoing remarks on the resistance experienced by plane surfaces moving through water will assist the reader in following the discussion of the more difficult problems connected with the resistances of ship-shaped solid bodies. In many of the earlier theories of resistance the immersed surface of a ship was assumed to be subdivided into a great number of pieces, each of very small area, and approximately plane. The angle of obliquity of each of these elementary planes with the line of advance of the ship—her keel-line—was ascertained; and its resistance was calculated exactly as if it were a detached plane moving alone at the assumed speed. For quantitative purposes, experiments were to be made with small planes of known area moved at known speeds, and set at different angles of obliquity; the resistances being observed. But obviously there was a radical error in applying unit-forces of resistance, obtained from the movements of detached planes, to the case of a ship where all the hypothetical elementary planes were associated in the formation of a fair curved surface, and none of them could have that eddying wake (like that in Fig. 117) which necessarily accompanied each experimental plane and formed so important an element of its resistance. This objection does not apply to the experiments made under the auspices of the French Academy of Sciences, during the last century, by Bossut, Condorcet, D'Alembert, Romme, and others; these experiments having been directed to the discovery of the resistances experienced by *solid bodies* of various forms moved at different depths. Very few of the models tried, however, had any pretension to ship-shaped forms; and this is also true of the subsequent experiments, made in this country, by Beaufoy.

Satisfactory experiments on the resistances of ships can alone be made with ship-shaped models of reasonable dimensions. This is the principle upon which Mr. Froude proceeded in his experiments, and although many doubts were expressed at first respecting the correctness of the results deduced from models when applied to full-sized ships, there are now good reasons for

trusting that method, some of which reasons will be stated further on.

The modern theory of resistance does not make any hypothetical subdivision of the immersed surface of a ship, but regards it as a whole. When such a surface, with its fair and comparatively gentle curves (like those in Fig. 118), is submerged and drawn through water, the particles are diverted laterally, and can glide over or past the ship without sudden or abrupt changes of motion, corresponding to those which occur when particles escape over the edge of the plane in Fig. 117. The paths of the particles are indicated roughly in Fig. 118 by the curved lines, the ship-shaped body being shown in black. After passing the broadest part of the vessel, the particles close in over the after part, and, gliding over the continuous surface, form a wake astern.

In the modern theory, the total resistance is considered to be made up of three principal parts: (1) frictional resistance due to

FIG. 118. -

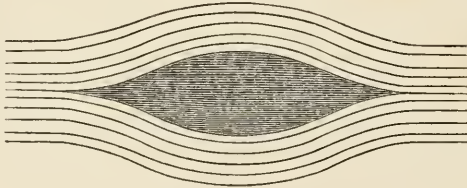

the gliding of particles over the rough bottom of the ship; (2) "eddy-making" resistance, at the stern; (3) surface disturbance, or wave-making resistance. The second of these divisions only acquires importance in exceptional cases; it is known to be very small in well-formed ships. It will, therefore, be necessary to bestow most attention upon frictional and wave-making resistance, to examine the conditions governing each, and to contrast their relative importance. It will be assumed throughout that the ship is either dragged or driven ahead at uniform speed by some external force which does not affect the flow of the water relatively to her sides. This is the condition always assumed when the *resistance* of a ship is being treated. It is advantageous to separate propulsion from resistance, since the latter depends in all ships upon the form, proportions, and condition of the bottom; whereas there are many means of propelling ships.

Suppose the ship to be moving ahead at uniform speed through an ocean unlimited in extent, and motionless except for

the disturbance produced by the passage of the ship. Under the conditions assumed, there will obviously be no change in the *relative* motions of the ship and the water if she is supposed to remain fixed, while the ocean flows past her at a speed equal to her own, but in the opposite direction to that in which the ship really moves. Making this alternative supposition has the advantage of enabling one to trace more simply the character of the disturbances produced by introducing the solid hull of the ship at a certain speed into water which was previously undisturbed. First, let the water be assumed to be frictionless, and the bottom of the ship to be perfectly smooth. These are only hypothetical conditions, but it is possible at a later stage of the inquiry to introduce the corrections necessary to represent the actual conditions of practice. Take any set of particles situated a long distance before the ship, and moving in a line parallel to her keel. If the ship were not immersed in the ocean current, these particles would continue to move on in the same straight line, which would be horizontal. When the ship is immersed her influence upon the motion of the particles may extend to a very long distance ahead, but there will be some limit beyond which the influence practically does not extend; and outside this, the particles whose motion is being traced will be moving at a steady speed in a horizontal line parallel to the keel. As they approach the ship, however, their path must be diverted in order that they may pass her; and this diversion will be accompanied by a change in their speed. Supposing for the sake of simplicity that the particles maintain the horizontality of their motion and are only diverted laterally: then, as they approach the bow of the ship, they will move out sideways from the keel-line, and lose in their speed of advance. Many considerations must govern the extent of this lateral diversion and loss of speed; such as the form of the bow, the extreme breadth of the ship, and the athwartship distance from the line of the keel of the original line of flow of the particles. At the broadest part of the ship amidships the velocity of the particles of water must be greatest, because the breadths of the "streams" (see page 443) in which they flow, are there less than at the bow, and the same quantity of water has to pass the two places. After the midship part of the ship has been passed, and her breadth begins to decrease, the path of the particles will converge towards the keel-line; and their speed will again receive a check. Finally, after flowing past the ship, and attaining such a distance astern as places them beyond the disturbing influence of the ship, the

particles will regain their original direction and speed of flow, provided that there is *no surface disturbance*. This last-mentioned condition could only be fulfilled in the case of a vessel wholly immersed, at a great depth, below the surface of an ocean limitless in depth; in the case of the ships which are only partly immersed, the retardations and accelerations described must cause the formation of bow and stern waves, and these we shall consider further on.

Although we have assumed, for the sake of simplicity, in the foregoing remarks that the particles maintain their horizontality of flow, it should be understood that the assumption is not supposed to represent the actual motion of the water in passing a ship. Diversion from the original line of flow is almost certain to have a vertical as well as a lateral component; but as to the paths actually traversed by the particles, we have little exact knowledge. Mr. Scott Russell is of opinion that at the foremost part of a ship the particles move in layers which are almost horizontal; while at the stern the particles have a considerable vertical component in their motion, besides converging laterally. Professor Rankine asserts that "the actual paths of the particles of water "in gliding over the bottom of a vessel are neither horizontal "water-lines nor vertical buttock-lines, but are intermediate in "position between those lines, and approximate in well-shaped "vessels to the lines of shortest distance, such as are followed by "an originally straight strake of plank, when bent to fit the "shape of the vessel." But, whatever paths may be followed, if at a considerable distance astern of a ship, wholly submerged in a frictionless fluid, the particles have regained their original direction and speed of flow, which they had at a considerable distance ahead of the ship, then their flow past the ship will impress no end-wise motion upon her. To this point we shall recur.

Professor Rankine has laid down geometrical rules for constructing the paths, or "stream-lines," along which the particles of a frictionless fluid would flow in passing a body very deeply submerged, supposing the particles to move in plane layers of uniform thickness. Fig. 119 was constructed by Mr. Froude in accordance with these rules.* The form of the immersed body with its comparatively blunt bow and stern is indicated in black;

* See the address to the Mechanical Section of the British Association in 1875. Professor Rankine's method is

described at pages 106, 107 of *Ship-building, Theoretical and Practical*.

the curved lines indicate the paths of particles. Between any two of these stream-lines, the same particles would be found throughout the motion, and these would form a "stream" of which the stream-lines mark the boundaries. It will be noted that, as the streams approach the bow, they broaden, their speed being checked, and the particles diverted laterally; the amount of this diversion decreases as the athwartship distance of the stream from the keel-line increases, and at some distance athwartship the departure of the stream-lines from parallelism with the keel, even when passing the ship, would be very slight indeed. As the streams move aft from the bow, they become narrowed, having their minimum breadth amidships, where the speed of flow is a maximum. Thence, on to the stern, the streams converge, broaden, lose in speed, and finally at some distance astern resume their initial direction and speed. Since there is no friction, there can be no eddying wake.

FIG. 119

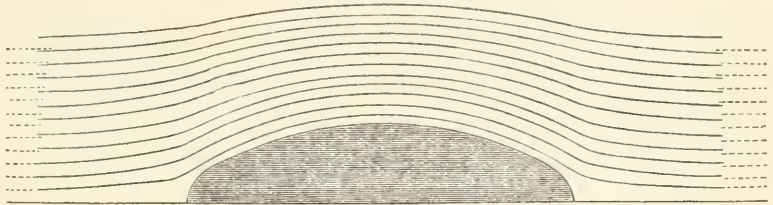

So much for a vessel wholly submerged; a ship only partly immersed would be differently situated, because even in a frictionless fluid she would produce surface disturbance. At the bow, where the streams broaden and move more slowly, a wave crest will be formed, of the character shown in Fig. 120; amidships, where the conditions are reversed, some depression below the normal water-line will probably occur; and at the stern, where the conditions resemble those forward, another wave crest will be formed. Between the bow and stern waves a train of waves may also exist, under certain circumstances. The existence of such waves, when actual ships are driven through the water, is a well-known fact; every one readily sees why, at the bow, water should be heaped up, and a wave formed, but the existence of the stern wave is more difficult to understand. As remarked above, there is but one reason for both phenomena. A check to the motion of the particles is accompanied by an increase of pressure; the pressure of the atmosphere above the water is practically constant, and hence the increase of pressure in the

water must produce an elevation above the normal level, that is to say, a wave crest. Conversely, amidships, accelerated motion is accompanied by a diminution of pressure, and there is a fall of the water surface below the still-water level, unless the intermediate train of waves should somewhat modify the conditions of the stream-line motion.

These waves require the expenditure of force for their creation, and, when formed, they may travel away into the surrounding

FIG.120

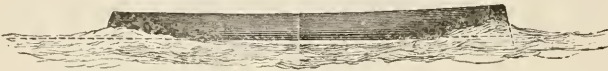

fluid, new waves in the series being created. In the case, therefore, of a ship moving at the surface of frictionless water, the only resistance to be overcome will be that due to surface disturbance. For the wholly submerged body which creates no waves there will be no resistance, when once the motion has been made uniform; the stream-lines once established in a frictionless fluid will maintain their motion without further expenditure of power.

This remarkable result follows directly from a general principle, which is thus stated by Professor Rankine:—"When a stream of

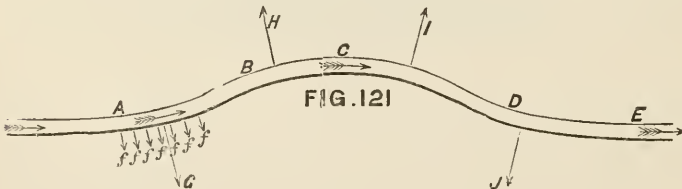

"water has its motion modified in passing a solid body, and re-
 "turns exactly to its original velocity and direction of motion
 "before ceasing to act on the solid body, it exerts on the whole
 "no resultant force on the solid body because there is no per-
 "manent change of its momentum." In every stream surround-
 "ing the submerged body in Fig. 119, this has been shown to hold;
 "each stream regains its initial direction and velocity astern of the
 "body. The partially immersed ship in the frictionless water
 "differs from the submerged ship in producing surface disturbance.

Perhaps the general principle will be better understood if we borrow one of Mr. Froude's many simple and beautiful illustrations. Taking a perfectly smooth bent pipe (Fig. 121), he supposes it to be shaped symmetrically, and divides it into four equal and

similar lengths, AB, BC, CD, DE. The ends of the pipe at A and E are in the same straight line; a stream of frictionless fluid flows through it, and has uniform speed throughout. From A to B may be supposed to correspond to the forward part of the entrance of a ship, where the particles have to be diverted laterally, and react upon the inner surface of the pipe, as indicated by the small arrows f, f, f , the resultant of these normal forces being G. At the other end of the pipe, from D to E may be taken to represent the "run" of a ship, where the stream-lines are converging and tending to resume their original directions; on DE there will be a resultant force J equal to G. Similarly, the resultant forces on the other two parts BC and CD are equal. The final result is that the four forces exactly neutralise one another, and there is no tendency to force the pipe on in the direction of the straight line joining A to E, although at first sight it would appear otherwise. The same thing will be true if, instead of being uniform in section, the pipe is of varying size; and if instead of being symmetrical in form, it is not so: provided only that at the end E the fluid resumes the velocity it had at A and flows out in the same direction. The forces required to produce any intervening changes in velocity and direction must have mutually balanced or neutralised one another, as in the preceding example, before the stream could have returned to its original velocity and direction of motion.

Applying these principles to the stream-lines surrounding a ship, it will be possible to remove one or two difficulties which have given rise to erroneous conceptions. It has been supposed, for example, that a ship in motion had to exert considerable force in order to draw in the water behind her as she advanced. As a matter of fact, however, the after part of a ship has not to exercise "suction" at the expense of an increased resistance, but sustains a considerable forward pressure from the fluid in the streams closing in around the stern. Any cause which prevents this natural motion of the streams, and reduces their forward pressure on the stern—such as the action of a screw-propeller—causes a considerable increase in the resistance, because the backward pressures on the bow are not then so nearly balanced by the forward pressures on the stern. Again, it will be evident that—apart from its influence on surface disturbance—the extent of the lateral diversion of the streams, in order that they may pass the midship part of the ship, does not affect the resistance so much as might be supposed; since the work done on the foremost part of the ship in producing these divergences is, so

to speak, given back again on the after part where the streams converge. Very considerable importance attaches, however, to the lengths at the bow and stern over which the retardations of the particles extend; since these lengths exercise considerable influence upon the lengths of the bow and stern waves created by the motion of the ship. And, further, the ratios of these lengths of entrance and run to the extreme breadth of the ship must be important, as well as the curvilinear forms of the bow and stern, since the extent to which the particles are retarded in gliding past the ship must be largely influenced by these features; and, as we have seen, the heights of the waves will depend upon the maximum values of the retardations. In other words, with the same lengths of entrance and run, differences in the "fineness" of form at the bow and stern may cause great differences in the heights of the waves created, as well as in the energy required to create and maintain such waves.

Such are the principal features of the stream-line theory of resistance for frictionless fluids and smooth-bottomed ships. The sketch has been necessarily brief and imperfect, but it will serve as an introduction to the more important practical case of the motions of actual ships through water. Between the hypothetical and actual cases there are certain important differences. First, and by far the most important, is the frictional resistance of the particles of water which glide over the bottom; secondly, friction of the particles on one another in association with certain forms, especially at the sterns of ships, may produce considerable eddy-making resistance, although this is not a common case; thirdly, friction may so modify the stream-line motions as to alter the forms of the waves created by the motion of the ship, and somewhat increase the resistance.

First, as to *frictional* resistance. Its magnitude depends upon the area of the immersed surface of the ship, upon the degree of roughness of that surface, or its "coefficient of friction," upon the length of the surface, and upon the velocity with which the particles glide over the surface. From what has been said above, it will appear that this velocity of gliding varies at different parts of the bottom of a ship, being slower at the bow and stern than it is amidships. Professor Rankine endeavoured to establish a simple formula for computing the resistances of ships when moving at speeds for which their proportions and figures are well adapted. Under these circumstances he considered that "the whole of the appreciable resistance" would result from the for-

mation of frictional eddies: in other words, that the wave-making factor in the resistance might be neglected. It is now known that this assumption was not a true one except for moderate speeds; whereas it was applied by Rankine to considerable speeds. On the other hand, his method of approximating to the frictional resistance and attempt to allow for variations in the velocities of gliding of the particles over the surface may still be studied with advantage. Rankine supposed that the wetted surface of a ship could be fairly compared with the surface of a trochoidal riband having the following properties:—(1) the same coefficient of friction as the bottom of the ship; (2) the same length as the ship; (3) a uniform breadth equal to the mean girth of transverse sections of the wetted surface: (4) an inflexional tangent, making an angle with the base of the trochoid, of which the value was to be deduced from a process of averages applied to the squares and fourth powers of the *sines* of the angles of greatest obliquity of the several water-lines in the fore body. For any trochoidal riband in which the angle made by the inflexional tangent with the base was ϕ , Rankine had previously obtained the following expression for the resistance due to frictional eddies.

$$\text{Resistance} = \text{Length} \times \text{Breadth} \times \text{Coefficient of Friction} \\ \times (\text{Speed})^2 \times (1 + 4 \sin^2 \phi + \sin^4 \phi).$$

The last term was styled the “coefficient of augmentation.” Hence

$$\text{Resistance} = \text{Coefficient of Friction} \times (\text{Speed})^2 \\ \times \text{“Augmented Surface.”}$$

And his supposition was that for ships of good forms a similar expression would hold, within the limits of speed usually attained. For clean-painted iron ships the formula was very simply stated:—

$$\text{Resistance} = \text{Length} \times \text{Mean Girth of Wetted Surface} \times \text{Coefficient of Augmentation} \times (\text{Speed in knots})^2 \div 100 \\ = \frac{\text{Augmented Surface} \times (\text{Speed in knots})^2}{100}.$$

This method of estimating the probable resistances of ships has been extensively employed by some shipbuilders, and is undoubtedly of use when the speeds to be attained are comparatively moderate. As the speeds increase, and the wave-making resistance assumes importance, the method necessarily fails; the total resistance then varies with a higher power of speed.

Mr. Froude investigated the frictional resistances of ship-shaped models, and as the result of a series of experiments came to a

conclusion which greatly simplifies the calculation of this important factor: viz. that no sensible error is involved in calculating the frictional resistance "upon the hypothesis that the immersed "skin is equivalent to that of a rectangular surface of equal "area, and of length (in the line of motion) equal to that of the "model, moving at the same speed." Hence, it is only necessary to experiment with such a plane surface as will enable the proper coefficient of friction to be found, then to measure the immersed surface of the ship, and to apply the coefficient, neglecting the variations in speed of the particles at different parts of the surface.

This method of estimating the frictional resistance on the immersed surface of a ship obviously takes no account whatever of the *forms* and *proportions* of ships. Two ships of very different forms, but of equal area of bottom and equal length, will have the same frictional resistance for the same speed; but they are likely to have different total resistances. The influence of form and proportion is greatest at high speeds, and it is chiefly felt in the direction of surface disturbance or wave-making; eddy-making or wake formation also depends upon form, especially at the stern.

The remarks made (on page 437) respecting the general character of frictional resistances to the motion of planes, apply also to the case of the curved wetted surfaces of ships; and, from an inspection of the coefficients of friction previously given, it is easy to see why foulness of bottom often causes a considerable reduction in the speed of ships. Furthermore it is most important in comparing the frictional resistances of a small model and a full-sized ship to make the necessary corrections in the coefficients of friction on account of differences in length. Such corrections must always appear in the records of model experiments. (See page 472.)

Frictional resistance is the most important element of the total resistances of most ships; and in well-formed ships moving at moderate speeds it constitutes nearly the whole of the resistance. This fact has been established experimentally, but was predicted on theoretical grounds. The experiments made by Mr. Froude on her Majesty's ship *Greyhound*, and those made by him on numerous models, show that for speeds of from 6 to 8 knots—or about the half-speed of ordinary ships—the frictional resistance with clean bottoms is 80 or 90 per cent. of the total resistance, and at the full speeds, even of the swiftest ships, the frictional resistance equals 50 or 60 per cent. of the total resistance. When the bottoms become foul, and the coefficients of friction

are doubled or trebled in consequence, frictional resistance, of course, assumes a still more important place; the practical effect of which is, as already remarked, a great loss of speed, or a considerably greater expenditure of power in reaching a certain speed.

Second, as to *eddy-making* resistance. It is generally agreed that in well-formed ships with easy curves at the entrance and run (more particularly the latter) this factor in the resistance is comparatively unimportant. Experiments indicate that eddy-making ordinarily bears a fairly definite proportion to frictional resistance; and Mr. Froude estimated eight per cent. of the frictional resistance as a fair allowance for eddy-making in a well-formed ship, when (to revert to our old illustration) the stream-lines would converge easily towards the stern, and have regained very nearly their original velocities and directions before they leave the ship. With a full stern, and abrupt instead of gently curved terminations to the water-lines of a ship, the particles of water cease to act upon her at a period when they still retain a considerable forward velocity; and the momentum thus created, and not given back in forward pressure on the stern, is a virtual increase to the resistance. Behind the stern of such a vessel will lie a mass of so-called "dead-water," an eddying wake like that behind the plane in Fig. 117. Such a form of stern is objectionable, and is never adopted unless its use is unavoidable in order to fulfil other and more important conditions than those affecting the resistance. The floating batteries built during the Crimean War were constructed with very full sterns, and great displacement in proportion to their extreme dimensions; their performances under steam were very indifferent as compared with those of better-formed ships. But they were designed for very special services, to float heavy guns and armour, and economical propulsion was not made a feature in their designs.

In order to diminish eddy-making resistance as much as possible, careful attention must be given to the forms of the various adjuncts to a ship, as well as to the shape of the ship herself. Outlying pieces—such as stern-posts, rudders, struts to shaft-tubes in twin-screw ships, supports to sponsons in paddle-steamers, &c.—may occasion a sensible increase to the total resistance, if improperly shaped. No general rule can be laid down in this matter; but Mr. Froude pithily expressed an important fact when he said, "It is blunt tails rather than blunt noses that cause eddies." In other words, the after terminations of outlying parts should be made as fine as possible consistently with other requirements.

Next as to *wave-making* resistance. The general character of the causes which create waves at the bows and sterns of ships moving in a frictionless fluid have already been sketched on page 443. Similar causes operate when the motion takes place in water, although the friction of the particles against each other and against the surface of the ship affect both the dimensions and positions of the waves. At the bow and stern, the motion of the particles of water relative to the ship has its minimum, and there are wave crests; amidships the relative motion has its maximum speed, and there may be a wave hollow. In other words, considering the ship as in motion and the water as motionless except for the motion she impresses upon it, the particles of water at the bow and stern will have motion in the same direction as the ship; those amidships will have motion in the opposite direction. Besides these two principal wave crests at the bow and stern, there may be other minor waves created; the great principle being that a crest will be formed wherever the particles attain a maximum speed in the direction of the advance of the ship; and a hollow will be formed where the particles have a maximum speed in the opposite direction. The principal waves at the bow and stern will each be followed by a train of waves, successive waves in the series having diminished heights.

It will, of course, be remembered that throughout this discussion no propeller is supposed to be in action, which could modify the relative motions of the water and the ship. But it is worth notice that the action of propellers may create additional wave crests, or modify considerably those formed by the ship. Paddle-wheels, for example, placed nearly amidships accelerate the sternward motion of particles, and produce an additional wave. Screw-propellers, on the contrary, being placed aft, give sternward motion to the particles, and tend to degrade the stern wave, as well as to cause considerably greater resistance by partially destroying the forward pressure of the water upon the stern; but they also create a local upheaval of the water, and confuse the phenomena of the waves.

The laws which govern the wave-making resistance of ships are not yet fully understood, systematic investigation of the subject having been begun within the last half-century. Mr. Scott Russell was one of the earliest workers in this field, and made a large number of experiments, chiefly upon canal boats and small vessels, before putting forward his well-known "wave-line" theory of constructing ships. The theory is not in complete

accordance with more recent investigations, but it has the great merit of having enforced the importance which might attach to the wave-making factor in the resistance, unless the lengths of "entrance" and "run" in a ship were suitably proportioned to her intended maximum speed. By the "entrance" is meant that part of a ship bounded by the stem and by the foremost athwartship section which has the full dimensions of the midship section: the "run" is the corresponding length at the stern; and the "middle-body," or "straight of breadth," is that part of a ship amidships where the cross-sections maintain the form of the midship section. The entrance and run have also been termed the "wave-making features," because the waves which accompany a ship are produced, as we have seen, by the accelerations and retardations of the particles of water resulting from the motion of the entrance and run relatively to those particles. It is obvious on reflection that the *lengths* as well as the *forms* of entrance and run must greatly influence both the bow and the stern waves. During each interval occupied by a ship in advancing through a distance equal to the length of her entrance the sets of particles then contiguous thereto undergo accelerations which lead to the production of the bow-wave; and this interval of time depends upon the ratio of the length of entrance to the speed of the ship. Similarly, importance must attach to the ratio of the length of the run to the speed. If a ship be formed so that these ratios are suitably adjusted for the maximum speed she is destined to attain, and the curves of the bow and stern are easy and fair, it may be hoped that the wave-making resistance will not assume undue importance. When such a ship has reached her uniform speed and the waves have been fully formed, the maintenance of those waves will require but a comparatively small expenditure of force. In fact, the case is parallel to that of the deep-sea waves (described at page 202), which will travel over immense distances without any great loss of speed; but with this important difference that, whereas the ocean-waves gradually become degraded, the waves accompanying ships, under the favourable conditions described, are kept to their full heights at the expense of a virtual increase in the resistance.

If the lengths of entrance and run are not suitably adjusted to the maximum speed of the ship, the waves which are formed, or a certain portion of them, diverge from her path, carrying off into still water the energy impressed upon them. The ship has, therefore, to be continually creating new waves, and the expenditure of force involved in this creation may form a very serious feature

of the total resistance. Moreover, when the speed of a ship exceeds that of the waves which her entrance and run naturally tend to form, other series of waves make their appearance, even more important than the diverging waves, and requiring a very large expenditure of power for their maintenance. These waves have a length proportioned to the speed of the ship, and actually keep pace with her; although the wave-making features of the ship are not adapted to their formation on account of the inadequate lengths of entrance and run.

It is now universally admitted that for every vessel there is a certain limit beyond which increased speed can only be secured at the expense of a very rapid growth in resistance. This limit is "somewhat less than that appropriate to the length of the wave which the ship tends to form," which length obviously bears a close relation to the length of entrance and run.* This general endorsement of a principle first enunciated by Mr. Scott Russell naturally leads to a closer consideration of his wave-line theory.

According to this theory the water displaced by the bow of a ship forms a "solitary" wave, wholly situated above the level of still-water, and travelling as a heap of water. This bow-wave is sometimes styled the "wave of displacement," and its companion stern-wave is named the "wave of replacement." The latter wave Mr. Russell supposed to be the leading wave in a trochoidal series resembling the deep-sea waves described in Chapter V. In order to prevent undue wave-making, the theory prescribed that the length of entrance given to a ship should be at least equal to the length of the solitary wave having a natural speed equal to the maximum speed proposed for the ship; and the length of run should be two-thirds the length of the entrance. Rules were also laid down for guidance in designing the forms of the entrance and run, so that the resistance might be minimised, but these need not be reproduced here.† For deep water and for the small heights which waves attain when travelling with ships, no error of practical importance is involved in estimating the period and speed of solitary waves of translation by the rules previously given for trochoidal waves. In shallow water there would be a necessity for considering the waves of translation separately, and also for altering the rules given for the

* The apparent exceptions to the foregoing statement furnished by torpedo-boats and swift launches are discussed on page 466.

† Particulars will be found in Mr. Russell's work on *Naval Architecture*, also in vols. i. and ii. of the *Transactions of the Institution of Naval Architects*.

trochoidal deep-sea waves; but into these special circumstances it is not necessary to enter, since they are important only in vessels designed for river or shallow-water service, and scarcely affect sea-going ships. Treating the wave of translation as a trochoidal wave in the relation of its length and velocity, the rules of Mr. Scott Russell may be stated in the following simple form:—Let V be the maximum speed of the ship (in knots per hour); L_1 be the length of entrance appropriate to the speed V , and L_2 the length of run (both lengths being expressed in feet): then

$$\begin{aligned} L_1 &= 0.562 \times V^2, \\ L_2 &= 0.375 \times V^2 = \frac{2}{3} L_1. \end{aligned}$$

For example, let $V = 15$ knots, then, to avoid undue wave-making the theory prescribes:—

$$\begin{aligned} \text{Length of entrance} &= 0.562 \times 15^2 = 126 \text{ feet;} \\ \text{Length of run} &= 0.375 \times 15^2 = 84 \text{ feet.} \end{aligned}$$

With these dimensions Mr. Scott Russell considered there might be associated any required length of middle body, the additional resistance for the assigned speed being chiefly due to friction on the enlarged immersed surface.*

Of these two rules, that relating to the length of run is thought to have the greatest practical importance, many successful vessels having had a less length of entrance than that prescribed by the formula; whereas vessels with shorter runs than the formula prescribes have done badly. As a matter of fact, however, sea-going vessels usually have greater lengths both of entrance and run, in proportion to their maximum speeds, than are required by these rules; and instead of having the run only two-thirds as long as the entrance, the lengths of entrance and run are commonly equal, or nearly so.

It will be observed from the preceding formula that

$$L_1 + L_2 = 0.937 V^2;$$

whence

$$V^2 = 1.067 (L_1 \times L_2); \text{ and } V = 1.03 \sqrt{L_1 + L_2} \text{ (nearly).}$$

So far as can be seen at present, this last equation enables a fair approximation to be made to the speed (V) at which a small increase in speed causes an increase in resistance altogether disproportionate to that which would accompany an equal increase in speed when the vessel was moving more slowly. Putting the

* See further on this subject the experiments of Mr. Froude mentioned at page 457.

equation in this form allows for any variations which may be desirable in practice in the ratio of the length of entrance to that of run; although neither of these can become very short in proportion to the speed without producing increased resistance. Suppose, for instance, that the common practice is adhered to, and the lengths of entrance and run made equal to one another: it may be desired to know what are the lengths appropriate to a speed of 16 knots. Here

$$L_1 + L_2 = 0.937 \times (16)^2 = 240 \text{ feet (nearly).}$$

Professor Rankine, in 1868, suggested another mode of determining the limit of speed at which wave-making resistance begins to grow at a very disproportionate rate.* Taking the quotient of the volume of displacement divided by the area of the load-water section of a ship, he termed it the mean depth of immersion (k). The velocity of the waves which are formed by a ship he considered to be equal to that acquired by a heavy body in falling freely through a distance equal to half the mean depth of immersion; this velocity might therefore be expressed approximately by the formula

$$\text{Velocity (feet per second)} = 4\sqrt{2k}.$$

If the actual speed of the ship exceeds this natural velocity of the waves formed by her advance, those waves will become divergent, and the wave-making factor of the resistance will increase. In other words the limiting speed for economical propulsion is that expressed in the above formula. This theory was tested by observations made during the steam-trials of actual ships, and was fairly confirmed; but the observations were not sufficiently numerous to justify the general adoption of the method.

The experimental researches of the late Mr. Froude and of his son, Mr. R. E. Froude, have considerably advanced our knowledge of the general character of the waves which accompany ships. Those experiments have mostly been made on models; but the wave-phenomena thus observed have been repeatedly compared with similar observations made during the steam-trials of ships belonging to the Royal Navy. According to these observations the waves produced by the motion of ships in deep water previously undisturbed may be classified as follows:—(1)

* See *Transactions* of the Institution of Naval Architects for 1868. The experiments made to test this theory were conducted by Mr. John Inglis, jun.

waves produced by the advance of the bow ; (2) waves produced by the stream-line motions near the stern. Of these, the bow waves are more important. Each of these sets of waves may be divided into two distinct series :—(1) *diverging waves*, the crest-lines of which trail aft ; (2) *transverse waves*, of which the crest-lines are nearly perpendicular to the keel-line of the ship. Mr. Froude did not agree with Mr. Scott Russell as regards the bow producing a solitary wave of translation ; but considered that all the waves produced in deep water are gregarious (like deep-sea waves described in Chapter V.), successive crests following one another at regular intervals ; those intervals, as well as the heights of the waves, varying with changes in the speed of the ship.

Taking the bow-waves, for example, the highest crests appear near the bow of a ship, and against her sides. The lengths of the waves, measured outwards from the ship along the crest-lines, are only moderate, and they gradually die away to the level of still water towards the outer ends. The leading wave in each series is followed by a number of other waves, of which the heights gradually diminish as their distance from the bow increases, but the actual termination of the series of waves cannot be distinguished. Similar remarks apply to the two classes of stern-waves. At low speeds neither the diverging nor the transverse waves attain such dimensions as to practically affect the resistance. At moderate speeds the diverging waves become apparent, and their crest-lines are commonly inclined aft at an angle of 40 to 50 degrees to the keel-line. It appears that only the leading wave in the diverging series at the bow touches the side of the ship in most cases, the highest points in the following waves in that series being at some distance from the ship. In other words, as the wedge-shaped entrance is driven forward it “throws off on each side a local oblique wave of greater or less size, “according to the speed and the obtuseness of the wedge, and “these waves form themselves into a series of diverging crests “. . . which after becoming fully formed at the bow pass clear “away into the distant water and produce no further effect on the “resistance.” The “length,” measured normally to the crest-lines of these diverging waves, appears to agree, or nearly so, with that of deep-water waves travelling at the speed which the ship’s speed would give if resolved normally to the crest-lines. As the speed increases so do these diverging waves increase in magnitude, and represent a larger amount of resistance ; and the wave phenomena are complicated still further by the appearance and rapid growth of the transverse series of waves as that limit of speed is ap-

proached where the wave-making resistance begins to grow rapidly in importance. When that limit is passed the transverse series of waves becomes even more important, affecting the total resistance very largely and sometimes very singularly.

In Fig. 121*a* is reproduced a drawing prepared by Mr. Froude to represent the result of careful observations of the wave phenomena attending the motion at relatively high speed of a model having a long middle-body.* The drawing indicates the positions of the diverging waves, while the profile of the waves in the transverse series is defined against the side of the model. This profile was drawn from exact measurements, but the vertical scale is exaggerated for the sake of clearness, so that the waves appear

FIG 121 *a*

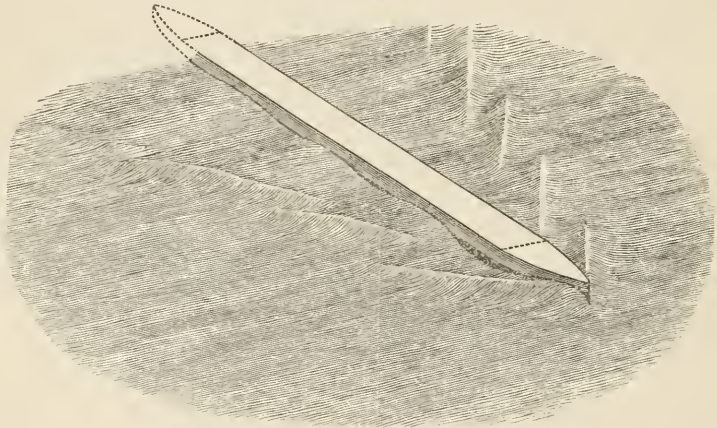

about twice as high as they really were relatively to the model. Unlike the diverging waves, those in the transverse series appear directly behind one another, successive wave-crests and hollows reaching the sides of the ship. In the diagram the distance from crest to crest is about 115 feet, the speed of the model corresponding to about $14\frac{1}{2}$ knots per hour for a full-sized ship. It will be observed that (in accordance with the formula on page 187) an ocean wave having this speed would be about 120 feet in length, so that there is a very fair agreement between the observed waves and trochoidal waves of equal speed. Hence it appears that as the speed of a ship is increased, so the lengths from wave-crest to wave-crest will increase in the ratio of the squares of the speeds; and the

* See the *Transactions* of the Institution of Naval Architects for 1877.

positions of wave-crests and hollows must vary, relatively to the ship, as her speed is varied. These variations in the relative positions of the waves and the after body of the ship were found, on analysing the results of numerous experiments, to sensibly affect the resistance of models having identically the same entrance and run, with Fig. 121*a*, but varying lengths of middle-body.

The earlier investigations of the late Mr. Froude on this important feature of wave-making resistance were made with a series of models having the same lengths and forms of entrance and run (160 feet), but varying lengths of middle-body—ranging from 340 feet down to nothing. The maximum speed appropriate to this length of entrance and run, according to the formula on page 454, would be rather less than thirteen knots; and so long as this speed was not exceeded, the wave-making resistance remained nearly of constant amount for all the models. At higher speeds considerable differences in the wave-making resistance were produced by variations in the total lengths of the models. When the length and speed of a model were such that a wave-crest of the transverse series was placed at or near the middle of the length of the run, the wave-making resistance was decreased. On the contrary, if the length and speed were so related that a wave-hollow of the transverse series occupied the position named, an increase in the wave-making resistance took place. Hence Mr. Froude argued that the absolute length of a ship, as well as her length of entrance and run, must affect her resistance when moving at relatively high speeds; and that variations in speed must influence the resistance by altering the relative positions of the hollows and crests of the transverse series of waves situated near the stern of a ship.

These conclusions have been confirmed generally, and our knowledge of the subject much extended by the investigations of Mr. R. E. Froude.* It is impossible here even to summarise the valuable experimental results, and the provisional theory based upon the experimental investigations, which constitute the most recent addition to this branch of the science of naval architecture. By means of elaborate observations of the wave-phenomena accompanying the motion of models through water, the general characteristics of the bow and stern series of waves, classified above, have been determined. Moreover, it has been shown that

* See the Paper "On the Leading Phenomena of the Wave-making Resistance of Ships."—*Transactions* of the Institution of Naval Architects for 1881.

the variations in wave-making resistance accompanying variations in speed, after a certain limit of speed has been passed in a given ship, may probably be explained by the "interference" of waves belonging to the transverse bow series, with the leading wave in the transverse series originated at the stern. That is to say—"the height of the waves made, and the amount of the resistance caused, will be at the maximum or minimum according as the crests of the bow-wave series coincide with the crests or troughs of the natural stern-wave series. . . . In either of these two cases the crest of the resultant wave coincides with the crest of the larger of the two components, while, if the crests of one series fall on the slopes of the other, the resultant crest position will be a compromise between the crest positions of the components, though nearer to the larger of the two."

The increase or diminution in resistance produced by variations in the relative positions of the wave-crests or hollows near the stern of a ship, is governed by various considerations. For example, the height of the leading transverse wave in the bow series is affected by the form of the entrance of a ship and the speed at which she is driven. Again the height of the crest in that wave of the transverse bow series which lies on or near the stern, as compared with the height of the leading bow wave, will depend upon the number of intervening waves, which number will depend upon the length and speed of the ship. The form of the stern and speed of the ship also influence the magnitude of the waves originating there, and so of the waves composed of the bow and stern series. These general considerations do not, however, enable an exact estimate to be formed of the magnitude of wave-making resistance in a ship of given form moving at a given speed, and for this purpose model experiments are essential.

The following passage in the remarks of Mr. R. E. Froude deserves quotation here, although it relates to a different aspect of wave-making resistance. He says:—"It is a reasonable inference . . . that the wave-making features of a ship will operate more effectively to make short waves if their displacement is disposed broadwise rather than deepwise; and more effectively to make long waves if it be disposed deepwise rather than broadwise. Now the diverging waves being necessarily much shorter than the transverse waves, we see that flaring-out the end sections of a ship, or increasing the ratio of breadth to depth will *cæteris paribus* tend to increase the resistance due to diverging waves and diminish that due to transverse waves: while giving V-sections or increasing ratio of depth to breadth will have the

“opposite effects. These inferences are visibly corroborated by
 “the appearance of the wave systems caused in the cases referred
 “to. Again it is worth noticing that the experiments at Torquay
 “have shown that, as a rule, moderately U-shaped sections are
 “good for the fore-body, and comparatively V-shaped sections for
 “the after-body. This would seem to show that in the wave-
 “making tendency of the after-body the diverging wave element
 “is less formidable than in that of the fore-body, and this infer-
 “ence corresponds with the fact that the stern diverging wave
 “series is visibly less marked than that of the bow.”

Another important deduction from these model experiments may be mentioned, before concluding our remarks on wave-making resistance. Supposing that the lengths of entrance and run provided in the design for a new ship to be ample in proportion to her intended full speed, a diminution in the total resistance may be usually secured by adopting still greater lengths of entrance and run, with finer lines at the extremities and a greater extreme breadth, the displacement remaining unchanged. This is contrary to the opinion formerly entertained as to the influence on resistance of an increase in the area of the immersed midship section; but there is ample evidence of the truth of the principle. An excellent illustration is found in the experiments made with a model of the merchant steamer *Merkara*, and models of alternative forms but identical displacement.*

The dimensions of two of these vessels (in feet) were as under:—

Models.	Length.				Extreme Breadth.	Mean Draught.
	Entrance.	Middle-Body.	Run.	Total.		
<i>Merkara</i> . .	144	72	144	360	37·2	16·25
Model B . .	179·5	Nil	179·5	359	45·88	18

The *Merkara* had an area of immersed surface of 18,660 square feet; model B an area of 19,130 square feet; the displacement in each case was 3980 tons. So far as surface friction went, therefore, the *Merkara* had a small advantage; as to eddy-making, the two ships must have been practically equal, and the difference between the two would arise from differences in the wave-making resistance. On trial it was found that about 18 knots marked the limit of speed for the *Merkara*, where a slight

* See the details given by Mr. Froude in vol. xvii. of the *Transactions* of the Institution of Naval Architects. The *Merkara* was built by Messrs. Denny.

increase in speed led to a disproportionately large increase in the wave-making resistance. At a speed of 19 knots the wave-making resistance of the model of the *Merkara* was found to be fully 60 per cent. of the whole resistance, whereas at the actual maximum speed of the ship—13 knots—wave-making resistance was only 17 per cent. of the whole. No limit of speed corresponding to 18 knots in the *Merkara* was found for model B up to speeds of 19 or 20 knots; and this want of any disproportionate increase in the wave-making made the resistance of B at a speed of 18 knots only 75 per cent. that of the *Merkara*, whereas at 13 knots the difference in the resistances was very trifling.

Applying the formulæ of the wave-line theory to these two vessels, we have—

$$\text{For } \textit{Merkara} \sqrt{L_1 + L_2} = \sqrt{288} = 17 \text{ (nearly).}$$

$$\text{Limiting speed } V = 17 \times 1.03 = 17\frac{1}{2} \text{ knots (nearly).}$$

$$\text{For model B } \sqrt{L_1 + L_2} = \sqrt{359} = 19 \text{ (nearly).}$$

$$\text{Limiting speed } V = 19 \times 1.03 = 19.57 \text{ knots (nearly).}$$

There is consequently a close agreement between theory and experiment as to the limit of speed beyond which the growth of resistance becomes disproportionately great.

Summing up the foregoing remarks, it appears:—

(1) That *frictional resistance*, depending upon the area of the immersed surface of a ship, its degree of roughness, its length, and (about) the square of the speed, is not sensibly affected by the forms and proportions of ships: unless there be some unwonted singularity of form, or want of fairness. For *moderate* speeds, this element of resistance is by far the most important: for *high* speeds, it also occupies an important position—from 50 to 60 per cent. of the whole resistance, probably, in a very large number of classes, when the bottoms are clean; and a larger percentage when the bottoms become foul.

(2) That *eddy-making resistance* is usually small, except in special cases, and amounts to some 8 or 10 per cent. of the frictional resistance. A defective form of stern causes largely increased eddy-making.

(3) That *wave-making resistance* is the element of the total resistance which is most influenced by the forms and proportions of ships. Its ratio to the frictional resistance, as well as its absolute magnitude, depend upon many circumstances; the most important being the forms and lengths of the entrance and run,

in relation to the intended full speed of the ship. For every ship there is a limit of speed beyond which each small increase in speed is attended by a disproportionate increase in resistance; and this limit is fixed by the lengths of the entrance and run—the “wave-making features” of a ship.

The sum of these three elements constitutes the total resistance offered by the water to the motion of a ship towed through it, or propelled by sails; in a steamship there is in addition an “augment” of resistance due to the action of the propellers, as will be explained hereafter (see Chapter XIII.).

In preparing designs for ships the naval architect commonly has to choose forms and proportions that will enable certain conditions to be fulfilled, and to make considerations of diminished resistance subordinate to those conditions. This is particularly true in war-ship design. For example, *handiness* is held to be an essential quality in most classes of war-ships, and handiness can only be secured in association with moderate lengths, rarely exceeding 300 to 350 feet in the largest modern armoured vessels, and only reaching 400 feet in a few vessels. In merchant ships, on the contrary, the power of turning rapidly is less valued, and lengths of 500 to 550 feet are by no means uncommon. Again, in war-ships the vertical distribution of the weights is fixed with especial reference to their powers of offence and defence; heavy weights of guns, armour, &c., are carried high up, and consequently the ratios of length and draught to beam, as well as the under-water forms, have to be largely influenced by the necessity for providing sufficient stability. Merchant ships, on the other hand, carry their heavy weights of cargo comparatively low down in the holds, and can be made sufficiently stable for all practical purposes with ratios of length and draught to beam which are scarcely possible in war-ships. Ships of the central citadel type afford still more striking instances of the difference now under consideration. In them the beam is made proportionately greater than in ships with armoured belts throughout the length in the region of the water-line, so that the ships may retain sufficient stability when the unarmoured ends are riddled. The provision of good sail power as well as steam power also affects the forms of many classes of war-ships, moderate length and considerable beam being necessary to secure stiffness and handiness when under sail. Even in merchant sailing ships, with their radically different vertical distribution of weights, greater ratios of length and draught to beam can be accepted than are adapted to the conditions of war-ships with steam and sail; and in merchant steamers

wherein sail is quite subordinated to steam the difference is still greater.

Her Majesty's ship *Greyhound*, of which the name has become well known in connection with Mr. Froude's experiments, is in all respects a contrast to the merchant steamer *Merkara*, and a comparison of the resistances experienced by the two vessels when moving at the same speeds will serve to point the preceding general statement. The following are the particulars of the *Greyhound*:—Length (from stem to body-post) 160; breadth extreme, $33\frac{1}{2}$ feet; mean draught, $13\frac{3}{4}$ feet; displacement, 1160 tons; area of immersed surface, 7540 square feet. In order to ascertain the resistance the *Greyhound* was towed by the *Active* at varying speeds, the maximum being about 13 knots. When she moved through the water, the vessel necessarily communicated motions to the water in her neighbourhood; the general character of these motions having been indicated in the preceding sketch of the stream-line theory. Changes in her own speed must have been accompanied by corresponding changes in these motions; and thus, in addition to the ship herself, a certain weight of water, which may be regarded as associated with her, must have undergone changes of speed corresponding to those impressed on the ship. Mr. Froude obtained data from which to estimate this weight of water, making special experiments for the purpose, and found it to be about one-fifth or one-sixth the weight of the ship. The *virtual* weight of the *Greyhound*, when towed, was, therefore, about 1400 tons. The tow-rope strain, or resistance, corresponding to various speeds was found to be as under. For purposes of comparison, the corresponding approximate results for the *Merkara* are also given; her actual weight being 3980 tons, and her virtual weight perhaps 4600 or 4700 tons.

Speed of Ships.	Resistance (in Tons).	
	<i>Greyhound.</i>	<i>Merkara.</i>
4 knots	0·6	1
6 „	1·4	2·3
8 „	2·5	3·9
10 „	4·7	6
12 „	9	9

The full speed of the *Greyhound* when driven by her own steam power was 10 knots; at that speed the resistance was only $\frac{1}{2\frac{1}{10}}$ part of her actual weight; 13 knots is the full speed of the

Merkara; the corresponding resistance (11·5 tons) is only $\frac{1}{350}$ part of the actual weight. It will be remarked that for speeds, below 8 knots, where frictional resistance constitutes almost the whole resistance, the greater surface of the bottom of the *Merkara* makes her resistance greater than that of the *Greyhound*; but at the higher speeds the greater wave-making resistance of the shorter and smaller ship makes her resistance gradually approximate to that of the *Merkara*.

So long as frictional resistance forms the larger part of the total resistance, the law which was formerly received as general holds fairly well, the resistance varying nearly as the square of the speed. In the *Merkara*, for example, the law holds very closely up to the speed of 13 knots, at which the frictional resistance formed about 80 per cent. of the total. In the *Greyhound*, the same law holds very fairly up to about 8 knots only, the frictional resistance at that speed being about 70 per cent. of the total; but beyond that speed the gradual growth in importance of the wave-making factor makes the total resistance vary with a higher power than the square of the speed. At 10 knots it varies nearly as the cube of the speed; and at 12 knots, nearly as the fourth power, the frictional resistance then being only 35 per cent. of the total. This contrast illustrates the principle previously laid down that considerable lengths of entrance and run and fine forms are advantageous, not merely in adapting vessels for high speeds, but in keeping down the law of increase in terms of the velocity for more moderate speeds. If economical performance under steam had been the sole or principal condition to be fulfilled in the *Greyhound*, it would undoubtedly have been preferable to adopt greater proportions of length to breadth, and finer forms at the extremities; then, with the same lengths of entrance and run, associated perhaps with a certain length of middle body, there would probably be somewhat greater frictional resistance than in the actual ship, but a very considerable decrease in the wave-making resistance, and on the whole a less resistance would have to be overcome in obtaining the designed speed. Such latitude of choice in forms and proportions was not, however, possible in the design of the *Greyhound*. She was intended to be efficient under sail, as well as to have moderate speed under steam; hence, moderate proportions of length to breadth became necessary, in order to secure sufficient "stiffness," and handiness. It may be interesting to add that the lengths of entrance and run in the *Greyhound* were each 75 feet; so that, according to the formulæ on page 453, no abrupt and inordinate growth of wave-

making should have occurred during the experiments. Nor did any such sudden change take place; although the bluff form of the ship made the wave-making factor in the resistance of such considerable amount.

The tendency in the merchant service has been, for many years past, towards an increase in the proportion of length to breadth in steamers; and in Chapter X. several examples of the change have been given. The common plan is that illustrated in the *Merkara*, a certain length of parallel middle body being introduced between lengths of entrance and run, sufficient to prevent any undue growth of the wave-making resistance within the intended limits of speed. Continuance of this policy of construction, and the gradual advances made by the same owners on the lengths of ships, may be regarded as good evidence of its advantages from a commercial point of view. But having regard to the experiments above mentioned, and to the probability that higher speeds will be required in future ships, shipowners and shipbuilders may well consider whether the ratio of beam to length might not be increased advantageously, instead of adding largely to the length. Mr. Froude has demonstrated two most important facts. First, that within the ordinary limits of speed for merchant steamers (say, 13 knots) it would be possible to obtain as good results with a slightly greater draught and much more moderate proportions of length to breadth than are now commonly employed; and with a less area of immersed skin. The advantages of the more moderate proportions are greater handiness and stiffness, the requirement of less structural strength and weight of hull, and the less serious loss of speed resulting from foulness of bottom; the gain in all these respects is not unimportant. Secondly, that if very high speeds have to be attained—say, speeds of 18 to 20 knots—it is preferable to decrease the length of the middle body, or to have none; increasing the lengths to entrance and run at the expense of the middle body, and making the extreme breadth greater.

Mr. Froude summed up his investigation as follows:—*

“In view of the importance of large carrying power combined
“with limited draught—a limitation which the Suez Canal has
“done much to emphasise—and I may add, in view of the prac-
“tical sufficiency of what may be called moderate speed, the
“prevailing tendency to great length, including a long parallel

* See page 184 of the *Transactions* of the Institution of Naval Architects for 1876.

“middle body, is a fair result of ‘natural selection.’ This form, “if rationally treated, is perhaps, under the conditions indicated, “the best adapted for commercial success; though where deep “draught is unobjectionable, a shortened form with no parallel “middle would be, as I have shown, unquestionably superior; or “were it an object to obtain very high speed, without notable “increase of resistance, parallelism of middle body would even “with the longer form be inadmissible. The logic of the circum- “stances shapes itself thus:—Large displacement means large “dimensions, somehow or somewhere; but the limitation of “draught forbids enlargement of dimension except in the direc- “tion of length, since increased ratio of breadth to depth would “involve an objectionably raised metacentre, and objectionable “increase of skin; greatly extended length has, therefore, for “mercantile purposes become essential to large carrying power. “Now with a very long ship, if the ends are so far fined as in “effect to limit the resistance to surface friction, the parallelism “of the remainder clearly assigns a valuably increased carrying “power to the ship as a whole; or, what comes to the same “thing, secures a given carrying power with less total skin and “therefore less resistance at moderate speed.”

The principles of construction here set forth have since been applied to practice by several eminent private shipbuilders with the most satisfactory results; and it seems probable that, without sacrificing the undoubted advantages of great length, greater proportionate beam will be adopted in future merchant ships.

Although economical propulsion requires the provision of appropriate lengths and fineness of entrance and run, it is possible to drive vessels at speeds far exceeding those for which their dimensions would appear well adapted if judged by the ordinary rules. The fast torpedo-boats recently introduced are remarkable illustrations of this statement. Vessels from 50 to 100 feet in length have been driven at speeds of 16 to 22 knots an hour; for which speeds, according to the wave-line theory, the appropriate lengths of entrance and run would be from 250 to 500 feet. In these extreme cases, however, the expenditure of power in relation to the weights driven is abnormally great; and at the higher speeds there is a wide departure from the laws which usually hold good for the relation between the resistance and the speed of ships. It has been shown in the comparison between the *Merkara* and the *Greyhound* that for low speeds the resistance varied nearly as the square of the speed; and that as the speed increased the resistance varied at a higher power than the square of the speed.

This is the common case for ships of ordinary form moving at speeds for which their lengths of entrance and run would be considered fairly appropriate; it holds good also for the torpedo-boats so long as their speeds do not rise beyond the economical limit appropriate to their lengths. But as that limit is surpassed, so the power of the speed according to which the resistance varies first increases beyond the square, reaches a maximum, and finally at the abnormal maximum speed actually falls below the square: that is to say the resistance at the maximum speed varies at a less power of the speed, than it does at the low speeds of 6 to 8 knots, where frictional resistance is almost the sole obstacle to progress. This remarkable departure from ordinary rules was first remarked in the steam-trials of some of the earliest fast boats; it has since been confirmed by numerous steam-trials of similar vessels, and by model experiments conducted by Mr. Froude. The following is an example. The resistance of a boat about 80 feet long was found to vary nearly as the *square* of the speed up to 10 knots per hour; beyond this speed the power of the speed according to which the resistance varied gradually increased until at 13 knots it exceeded the *cube*; but when the speed had reached 17 to 18 knots the resistance varied at a less power than the square. Comparing this with the performance of Her Majesty's ship *Iris*, the behaviour of the torpedo-boat appears most remarkable. The *Iris* is 300 feet long and has attained a measured mile speed of $18\frac{1}{2}$ knots per hour. Up to 13 knots per hour the resistance varied nearly as the square of the speed; and the law of growth gradually increased with the speed until at 18 knots the resistance varied at a somewhat less rate than the cube of the speed. If it were possible to push the *Iris* to much higher speeds, there can be no question but that a change in the law connecting the resistance with the speed would occur similar to that which actually takes place in the torpedo-boat; only in the ship this change would not be reached until the speed of 30 to 40 knots per hour was attained. These are suggestive facts; of which a complete explanation has yet to be given. The wave-making phenomena accompanying the motion of ships at relatively high speeds have been very carefully observed by Mr. R. E. Froude, and the principal results are recorded in the Paper quoted on page 458. Extensive observations have also been made of the behaviour of torpedo-boats driven by their own engines. Hence it appears that, when at full speed, the torpedo-boats are carried on the back slope of a wave having a length corresponding very closely to the speed of the vessels. Great alterations of trim

also take place at these high speeds from the still-water condition, the bow rising and the stern falling. Mr. Yarrow has made a series of experiments on the changes of trim, accompanying changes in the speed of some of the torpedo-boats built by him; noting at the same time the profile of the wave water along the sides of the boat. From the results which he has communicated to the author one example has been taken, and illustrated by Fig. 121*b*. It is the case of a boat about 80 feet long steaming at a speed of $18\frac{1}{2}$ knots an hour. By *dotted* lines is shown the still-water condition of the boat, floating on an even keel: by *drawn* lines is shown her condition under steam, and the outline of the water at her side. She was found to alter trim about $\frac{1}{2}$ inch to the foot when under-way; which on her length would make a rise of 40 inches of the bow relatively to the stern. On the other hand, the bow rose relatively to the water surface rather more than a foot, while the stern sank less than six inches. In short, as was

FIG 121*b*

Fig. 121*b*.—*Note*. The *dotted* lines show the outline of boat and water-surface, when she is at rest in still water. The *drawn* lines show the corresponding particulars for full speed.

above remarked, the boat at this high speed was carried on the back slope of a wave which she had created, and which was travelling at about the same speed as herself.

The very great expenditure of power necessary to drive these small vessels at the higher speeds has already been mentioned; a few figures may serve to illustrate the statement. When the *Iris* is moving at the speed of eighteen knots, her resistance is less than the *one-hundredth* part of her weight; at the same speed in a torpedo-boat the resistance would be about *one-sixteenth* of the weight. When the *Shah* moves at a speed of 16 to 17 knots, less than *one-two-hundredth* part of her weight measures the resistance; for the torpedo-boat the corresponding resistance would be *one-twentieth* of her weight. At twelve knots the resistance of the *Merkara* is less than *one-four-hundredth* part of her weight; for the torpedo-boat the corresponding resistance would be about *one-fortieth* of her weight. Such comparisons as these are obviously incomplete, and throughout them the torpedo-boat is placed at a disadvantage because of her relatively small size (see the remarks on page 474), but they indicate the penalty which has to be paid when small vessels are driven at very high speeds.

In this connection it is natural that allusion should be made to the greatly increased speeds now (1882) realised by ocean steamers as compared with those attained ten years ago; and to the probability that yet higher speeds will be reached in future ships. Instead of averaging 10 to 12 knots, the fastest ocean steamers now average 14 to 16 knots, and other vessels are approaching completion which are expected to possess higher speeds. Without attempting to predict the extent to which progress may be made, it is evident that even with existing types of marine engines the limit of speed has not been reached, and will be fixed rather by commercial considerations than by any other. Increase in the sizes of ships and the power of engines may possibly go much farther; but higher speeds will be costly and will entail additional risks. There have been many proposals for modifying the forms of ships in such a manner as would enable them to attain extraordinarily high speeds on moderate dimensions; but none of these plans has yet found acceptance with naval architects, and it is certain that no modification of form can enable a vessel moving at high velocity through water to escape from a great resistance, involving a large proportionate expenditure of engine power. In the course of his experiments Mr. Froude has determined the resistances of models moving at speeds corresponding to from 50 to 130 knots per hour for full-sized ships. The results are most interesting and instructive, but they do not encourage the hope that, in practice, any such speeds will be realised.*

In the preceding pages it has been shown that the problem to be solved by the naval architect is not to determine any exact geometrical form of least resistance of which he can make use in all cases, but in the design of each ship to select the forms and proportions which are compatible with the special conditions to be fulfilled, and which will make the resistance as small as possible. Even when thus narrowed, the problem is one of considerable difficulty; mainly because of our ignorance of the laws which govern the wave-making resistance. At present only a few of the more important conditions influencing wave-making have been determined, and these rather in a qualitative than a quantitative fashion. The determination of the resistances of ships is, therefore, necessarily a matter of experiment in the present state of our knowledge; and apart from experiments great uncertainty must always attend estimates of the resistances of

* See Return No. 313 of 1873 to order of the House of Commons.

new types of steamships, as well as of the engine power required to attain certain speeds. This is especially true of types in which novel forms or proportions are introduced, or in which the speeds to be attained lie quite outside the range of previous experience. The case of vessels similar in form and not very different in speed from others which have been completed and tried can be dealt with, as will be explained in Chapter XIII.; but radical changes can only be made with any certainty on the basis of careful experiments, and such experiments are best conducted on models according to the system introduced by the late Mr. Froude. In 1868, a committee was appointed by the British Association to report "on the state of existing knowledge on the stability, propulsion and sea-going qualities of ships," and in their Report, presented in the following year, they recommended a series of experiments to be made in order to determine the resistances of full-sized ships, model experiments being regarded as of doubtful value. From this Report, Mr. Froude dissented, contending "that experiments on the resistances of models of rational size, when rationally dealt with, by no means deserve the mistrust which they are usually dealt with; but on the contrary can be relied on as truly representing the resistances of the ships of which they are the models." His views were supported by numerous experiments; and the value of the process by which, from a comparatively inexpensive series of experiments on models, a close approximation can be made to the resistances of ships being recognised by the professional officers of the Admiralty. Mr. Froude received assistance in the establishment of experimental works, which have continued in useful operation for the last ten years. During the greater part of that period Mr. Froude personally superintended the work, and his labours have been of the greatest value to the Royal Navy, at a time when changing conditions rendered the adoption of novel types and higher speeds imperative. Since his lamented death, the work has been continued, on behalf of the Admiralty, by his son, Mr. R. E. Froude. Similar experimental works have been established in Holland, and attempts in the same direction have been made in France and Italy. The establishment at Amsterdam is conducted with marked ability by Dr. Tideman, Chief Naval Constructor, who has published an interesting account of a long series of experiments made on models of different types of ships. At this place were made the experiments upon which the design of the yacht *Livadia* (built on the Clyde for the Emperor of Russia) was based. This remarkable vessel is 230 feet long, 150 feet broad, and of 8

to 9 feet draught, her form and proportions departing so considerably from those of any preceding vessel that it is difficult to conceive how any estimate of the engine-power could have been made independently of such experiments. It may reasonably be anticipated that this experimental method of comparing the merits of various forms will be extended hereafter so as to embrace the mercantile marine as well as the Royal Navy, and steps are already being taken to create an experimental establishment by one of the leading Clyde firms. Such an extension will undoubtedly be productive of large economies in steam-power and coal consumption in future merchant steamers; for similar savings have already been effected in war-ships. The following is an example:—

In designing the *Medina* class of river-service gunboats for the Royal Navy, the draught of water was limited to less than 6 feet, and the full speed was fixed at 9 knots. The question arose which of two forms would be preferable: a vessel having a length of 110 feet and an extreme breadth of 26 feet, or a vessel of equal length, but 34 feet broad, and having greater fineness and length of entrance and run. Having experimented with models of the two forms, Mr. Froude reported that the broader vessel with a displacement of 370 tons, would have only *two-thirds* as great resistance as the narrower vessel with a displacement of 350 tons. The results since obtained, on the measured-mile trials, with vessels built on the broader form, have fully confirmed the experiments made with the models. Without experiments the result could scarcely have been predicted; and it is a remarkable illustration of the fallacy of the opinion, formerly entertained very generally, that a greater area of midship section involved an increased resistance. The smaller actual resistance of the vessels with the larger midship sections was undoubtedly mainly due to the decrease in wave-making resistance produced by the longer and finer entrance and run. Whatever the explanation, there can be no question of the fact that this change of form was productive of a very advantageous diminution of resistance: saving one-third the engine-power required to attain the desired speed, and reducing the first cost of the machinery, as well as the cost of maintenance and repair during all the subsequent service of the numerous vessels in this class.

As such importance attaches to these experiments, it is desirable that, before concluding this chapter, a brief account should be given of the process by which the resistance of a full-sized ship is obtained from the ascertained resistance of the model. For

this purpose, Mr. Froude made use of a "scale of comparison," based upon the stream-line theory, and stated it as follows:—
 "If the ship be D times the dimension of the model, and if at the speeds $V_1, V_2, V_3 \dots$ the measured resistances of the "model are $R_1, R_2, R_3 \dots$, then for speeds $V_1\sqrt{D}, V_2\sqrt{D}, V_3\sqrt{D} \dots$ of the ship, the resistances will be $D^3R_1, D^3R_2, D^3R_3 \dots$. To the speeds of the model and ship thus "related it is convenient to apply the term *corresponding speeds*." This general statement will, perhaps, be better understood by an example; for this purpose we cannot choose a better example than that published by Mr. Froude for the *Greyhound*, and illustrated by Fig. 122.

The curve AA in the diagram is termed a "curve of resistance;" measurements along the base-line XY representing speeds

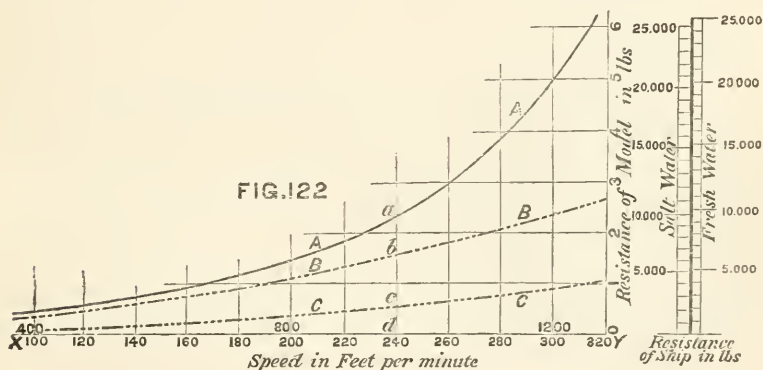

(in feet per minute), and the lengths of the ordinates drawn perpendicular to XY representing the resistances of a ship or model (in pounds) at the various speeds. To construct the curve, the model is towed at a certain speed—say, 240 feet per minute—and its resistance recorded by means of suitable dynamometrical apparatus; a length (ad , in Fig. 122) representing this resistance is then set off along the ordinate drawn perpendicularly to XY at the point (d) corresponding to the speed. This process having been repeated for a considerable number of speeds, a series of points (such as a) is determined, and through these the curve AA is drawn. By simple measurement of an ordinate of this curve the resistance can be ascertained at any speed within the limits over which the experiments extend. Having measured the immersed surface of the model, and ascertained by experiment its proper coefficient of friction, the

frictional resistance can be easily calculated for each of the experimental speeds. The value of the frictional resistance at each speed is then set off from the base-line XY, on the same scale as was chosen for the total resistance curve AA, the length db representing the frictional resistance at the speed of 240 feet. A curve of frictional resistance (BB) is thus obtained for the model; and this operation completes all that need be done for the model; furnishing the data from which the resistance of the full-sized ship can be estimated.

In the case of the *Greyhound* the model was *one-sixteenth* of the full size of the ship: hence for the scale of comparison mentioned above, $D=16$; $\sqrt{D}=4$; and the "corresponding speeds" of the ship will be *four times* those of the model. In Fig. 122 the speeds in feet per minute marked *below* the line XY are speeds for the model; those marked *above* the line are speeds for the ship. For resistances at the corresponding speeds, the law stated above becomes—

$$\begin{aligned} \text{Resistance of ship} &= (16)^3 \times \text{resistance of model} \\ &= 4096 \times \text{resistance of model.} \end{aligned}$$

This change, therefore, simply amounts to an alteration in the scale of measurement of the ordinates of the curve AA; whatever length represents 1 lb. for the model must represent 4096 lbs. for the ship. The appropriate correction is made in Fig. 122 by the scale of "resistance of ship" drawn at the right-hand side of the diagram. It will be remarked that this scale provides for resistance in fresh water, as well as in sea-water, the salt-water resistance exceeding that for fresh water in the ratio in which the density is greater than that of fresh water; but this is not an important feature of the experiments, having been introduced only because fresh water is used in the experimental tank. Having corrected the vertical scale of resistance in the manner described, it would be possible to measure the resistance of the ship for any speed from the ordinates of the curve AA, were not a correction needed in the frictional resistance on account of the length of the ship exceeding that of the model so greatly.* This difficulty Mr. Froude meets by a simple device. The frictional resistance of the ship is calculated for the various speeds, making use of her actual coefficient of friction (allowing for her greater length), and these values are set off (on the proper scale, and on ordinates representing the corresponding speeds)

* See the remarks on page 448.

downwards from the curve BB, which represents the frictional resistance of the model; through the points thus determined the curve CCC is drawn. Then, to determine the resistance of the ship at any speed, instead of measuring from the baseline XY, it is necessary to measure from the line CC.

Take, once more, the speed of 240 feet per minute for the model; this represents a speed of 960 feet for the ship (or about $9\frac{1}{2}$ knots per hour). The length *ac* on the ordinate, corresponding to this speed, represents the total resistance of the ship, on the proper scale; and the length *bc* represents on the same scale the frictional resistance of the ship, while *cd* represents the diminution of the frictional resistance of the ship as compared with the model, and will be seen to be of considerable amount.

In the conduct of these experiments the greatest care is needed to secure uniform motion of the models at any assigned speed, as well as the correct measurement of the strain on the towing apparatus, and the avoidance of any conditions which would render the behaviour of the model dissimilar from that of the ship represented when she is moving in smooth water of great depth and extent. It will be obvious that any errors made in the model experiments will be greatly magnified in passing from the model to the ship; but the possibility of such errors occurring has been minimised by the beautiful apparatus contrived by Mr. Froude, this apparatus being to a large extent automatic in its action and giving a continuous record of the results for each run of a model at a certain speed.* Supposing the data for the model to have been accurately determined, it is, however, obvious that its practical usefulness depends upon two conditions: (1) the accuracy of the law of "corresponding speeds;" (2) upon the possibility of making an approximation to the correction in frictional resistance required in passing from the model to the ship. Upon the second condition nothing need be added; but a few remarks in explanation of Mr. Froude's "scale of comparison" may be of service. Previous writers had remarked upon the impropriety of comparing the resistance of a ship with that of a model moving at the same speed; and M. Reech had pointed out that when the resistance varied as the square of the speed, if models of different sizes were moved at velocities varying as the square roots of their lineal dimensions, their resistances would vary as the cube of the lineal dimensions. This rule of M. Reech

* For details of this apparatus see vol. xv. of the *Transactions* of the Institution of Naval Architects.

is identical with Mr. Froude's scale of comparison, but rests upon a less general hypothesis; it can be easily demonstrated. Suppose a wholly submerged body to have S_1 square feet of wetted surface, then, for a speed of V_1 feet per second, we should have

$$\text{Resistance} = R_1 = K.S_1V_1^2 \quad \dots \quad (1),$$

where K is a coefficient determined by experiment. For another body of similar form, having the wetted surface S_2 and moving at the speed V_2 ,

$$\text{Resistance} = R_2 = K.S_2V_2^2 \quad \dots \quad (2);$$

whence it follows that

$$\frac{R_1}{R_2} = \left(\frac{V_1}{V_2}\right)^2 \frac{S_1}{S_2} \quad \dots \quad (3).$$

If the first body have lineal dimensions D times those of the second, then

$$\frac{S_1}{S_2} = D^2 \quad \dots \quad (4),$$

and further, if the velocities V_1 and V_2 are related to one another as the square roots of the lineal dimensions,

$$\frac{V_1}{V_2} = \sqrt{D} : \left(\frac{V_1}{V_2}\right)^2 = D \quad \dots \quad (5).$$

Substituting from (4) and (5) in (3) we have at these "corresponding speeds"

$$\frac{R_1}{R_2} = D \times D^2 = D^3;$$

so that, under this limited assumption as to the law of resistance, the "scale of comparison" holds good. Mr. Froude first showed that it held good generally for wave-making resistance, whatever might be the law of resistance; provided that the frictional resistance was separately considered. His reasoning may be briefly summarised.* According to the stream-line theory of resistance, the "displacements," which the motion of a wholly submerged body imposes on the surrounding volumes of fluid, "are for a given body identical in configuration at all velocities, "and this configuration is similar for all similar bodies." This law of similarity would also hold good for a partially submerged body, if the surface of the fluid were supposed to be uninfluenced

* See *Reports* of British Association for 1868.

by gravity, and consequently the wave phenomena—the “upward disturbances of the surface”—would be identical for the same body at all speeds, and be similar for similar bodies. As a matter of fact the elevations and depressions of the surface are the results of the joint action of gravity and the stream-line accelerations; and hence it follows that the surface disturbances in two similar bodies “will retain their similarity wherever, and in the manner “which, the operation of gravity permits; and this will be when “the similar bodies are moved with velocities proportioned to “the square roots of their respective dimensions.” When the two similar bodies move at those “corresponding speeds,” and the configurations of the waves are similar, the energy expended on wave-making will vary with the cube of the dimensions; because the mass elevated is as the square of the dimension, and the elevation is as the square of the speed, that is to say as the dimension.

The correctness of this reasoning has been verified by very many observations made on models of similar forms but different sizes, and by a comparison of the wave-phenomena of models with those of ships. It has already been remarked that careful observations of the waves accompanying models are usually made in association with the resistance experiments; and in several cases, notably those of the *Greyhound*, the *Shah* and the *Iris*, the waves raised by the ships themselves were carefully noted and found to be similar to those raised by the respective models. Having thus established the similarity for ships and models it is a great practical advantage to be able to study the wave-phenomena on the moderate scale in which they occur in model experiments, instead of having to deal with the large dimensions incidental to the motion of full-sized ships; Mr. Froude fully realised the possibilities thus opened to him, and one of the principal aims of his experiments was “to deduce general laws by which the influence of variation of form upon wave-making resistance might be predicted.” Unfortunately the task so ably undertaken was left incomplete; but, from the investigations already made by Mr. R. E. Froude (see page 458), it may be hoped that his intentions will yet be realised.

These model experiments have added greatly to our knowledge of many minor but interesting matters relating to the motions of ships through still water. For example, the recording apparatus devised by Mr. Froude enables a record to be kept of the vertical motions which the centre of gravity of the model performs as the speed is varied, as well as of the changes in trim. It has thus

been ascertained that ships moving at ordinary speeds usually sink bodily below their still-water draught, and that at such speeds the bow usually sinks more than the stern. There will be no difficulty in accounting for these changes of level when the character of the stream-line motions, and the variations in the resultant pressures of the water upon the different parts of the length of a ship are considered (see page 443); nor will it be a matter for surprise that when the cross-sections of the bow of a ship are V-shaped the subsidence is less than when those sections are U-shaped. Although the foregoing statement is fairly representative for ordinary conditions, it does not apply when ships are moved at velocities very high relatively to their dimensions. In torpedo-boats, for example, the ordinary laws hold good only for the lower speeds. Mr. Thornycroft has made some valuable experiments on this matter, and a brief summary of the results may be of interest.* A boat 67 feet long was driven at various speeds, the maximum being about 19 knots; observations were made from which the vertical position of the centre of gravity, and the trim of the boat could be determined at each speed. It was found that as the speed increased so the vessel sank more deeply up to about 12 knots; after which the boat rose as the speed increased. At 12 knots the bodily subsidence was about 5 inches, at 19 knots the bodily rise was 3 inches, these measurements being taken in relation to the still-water draught. In this case the boat trimmed by the stern, as compared with her still-water trim, throughout the trials; but it must be remembered that she was driven by her own propeller and not towed.

Experiments with models, made by Mr. Froude, have shown very similar results as regards mean draught and trim at very high speeds.† For example, a model about 10 feet long was towed at various speeds, the maximum being about 850 feet per minute—or $8\frac{1}{2}$ knots per hour. At first the trim altered very little from the still-water condition, but as the speed increased the bow gradually rose, while the stern fell. Ultimately at the maximum speed the bow had risen $2\frac{1}{2}$ inches, while the stern had sunk to an equal amount with reference to their still-water levels. This model represented a full-sized ship of 360 feet in length, and the maximum experimental speed represented a speed of more than 50 knots for the ship. The vertical displacements of the

* See the British Association *Reports* for 1875.

the proposals of the Rev. C. Ramus, published as *Parliamentary Paper*

† See the very admirable Report on

(No. 313) of 1873.

bow and stern of the ship if moved at this enormous speed would have been about $7\frac{1}{2}$ feet.

In conclusion, it should be mentioned that in the actual propulsion of a ship the air exercises an appreciable resistance, especially if she is a rigged ship; and that the resistance of the water in a seaway must be different from that of smooth water, which alone has been considered in this chapter. Respecting the last-mentioned feature, it will suffice to say that the state of the sea and the motions of pitching and rolling vary so greatly at different times that any attempt to express the increase in resistance by an exact method would be hopeless, even if there were a complete theory for resistance in smooth water. Experience, however, confirms the accuracy of an opinion which would be formed on the most superficial investigation, viz. that great length, size, and weight in ships give them a greater power of maintaining their speed in a seaway. The regularity of the passages made by the large Transatlantic steamers, under very various conditions of wind and weather, supply the best possible illustration of this general statement, which has, however, to do with propulsion rather than with resistance.

As to air resistance, there have been very few trustworthy experiments. Mr. Froude, in his experiments with the *Greyhound*, which was not rigged at the time, found that, when the speed of the wind past the ship was 15 knots per hour, it produced an effect on the hull measured by a force of 330 lbs. For other speeds of wind past the ship, it was assumed that the effect varied as the square of the speed; and it need hardly be added that in the case where a ship is steaming head to wind air resistance must be greatest, since the speed of the wind past the ship then equals the sum of her own speed and that of the wind. The absolute force of the air resistance in the *Greyhound* was thus found to be small; but if the vessel had been masted and rigged, the resistance would have been greater. Mr. Froude did not expressly state, in his report on this experiment, what scale of allowance he employed in estimating the additional resistance due to the passage of the masts and rigging through the air; but from the particulars which he subsequently furnished to the Author, it appears that the total resistance of the masts and rigging was taken about equal to that of the hull. At a speed of 10 knots through *still air*, this would give a total air resistance of about 300 lbs., the corresponding total of water resistance being about 10,200 lbs.; making the air resistance about $\frac{3}{34}$ part of

the water resistance. If the ship steamed head to wind at a speed of 8 knots, the actual speed of the wind being 7 knots, it would pass the ship with a relative speed of 15 knots; the air resistance would then probably have a total of about 650 lbs., whereas (if the water were smooth) the total water resistance would be about 5300 lbs., the air resistance rising to about $\frac{1}{3}$ of the water resistance. These results may not be exactly correct, but they are sufficiently so for illustrative purposes; they explain the considerable decrease in speed in ships—especially rigged ships—steaming head-to-wind; and they are so considerably in excess of what would have been predicted on purely theoretical grounds as to indicate the desirability of further experiments on the air resistance to rigged ships. Up to the present time, we have little information of an exact or trustworthy character on this important subject.

The experiments required are very simple. All that is necessary is to allow a ship to drift before the wind, to note the uniform speed which she will ultimately attain through the water, and to measure the velocity of the wind past the ship; her condition aloft must also be recorded, as to spars on-end, running rigging rove, &c. The water should be approximately smooth, and the ship should owe her drift simply to the air pressure, not to tides or currents. The resistance of the water at the uniform speed of drift must then exactly equal the total air resistance; and this water resistance could be ascertained by other experiments made either with the ship or with models. Accuracy would be increased and more valuable information obtained if the same ship were made the subject of several experiments, including two sets: one made with the same condition as to spars and rigging aloft, but with different forces of wind; the second set made with different conditions of rig, while the actual speed of the wind remained constant. This is a matter which will be likely to commend itself to the attention of naval men when they learn the imperfect condition of our present knowledge of the subject. Other modes of making the required experiments might be suggested did space permit; but it must suffice to add that, with the aid of suitable dynamometric apparatus and good anemometers, the air resistance corresponding to a certain speed of wind might be obtained with the ship moored instead of drifting.

As to the air resistance on the hull only, there appears good reason for adopting the rule which Mr. Froude has suggested, viz. that, if the above-water portions of the hull are projected back upon the midship section of a ship, and the total area (A) in-

closing these projections is determined, then the air resistance on that area (A) will approximately equal the air resistance on the hull for any assumed speed. In the *Greyhound* the area A was somewhat less than 400 square feet; Mr. Froude has ascertained by experiment that at a speed of 1 foot per second the air resistance per square foot on a plane area is about equal to $\frac{17}{10000}$ lb. A speed of 15 knots per hour equals about $25\frac{1}{3}$ feet per second; and since the air resistance varies as the square of the speed, the speed of 15 knots should correspond to a pressure of about 1.09 lb. per square foot of area. Hence the total air resistance on the *Greyhound* for a speed of 15 knots past the ship should be about 436 lbs. by this law; and by experiment it was determined to be 330 lbs. This approximate rule may be found useful for purposes of comparison between different types of ships; and in mastless ships it will give a fair estimate of the total air resistance at any assigned speed of wind past the ships. Rigged ships present a more difficult problem, which can be best dealt with experimentally.

CHAPTER XII.

PROPULSION BY SAILS.

THE efficient management of a ship under sail furnishes one of the most notable instances of skillful seamanship. In different hands the same ship may perform very differently. Changes in stowage and trim also affect the performance; but such changes as an officer in command can make are necessarily limited in their scope and character; and some ships can never be made to sail well, having some radical fault in their designs. Without intruding upon the domain of seamanship, the naval architect requires, therefore, to study very carefully the conditions of sail-power, and the distribution of sails in a new design, if the completed ship is to be fairly successful. His success or failure greatly depends upon the possession of information respecting the performances and sail-spread of ships of similar type and rig; having such information, the process by which the total sail-spread and the distribution of the sail are determined in the new ship is by no means difficult or complex. Taking the exemplar ships, and the reports on their sailing qualities, an analysis is made of the sail areas, the distribution of the sail longitudinally and vertically, the transverse stability, and some other particulars. Furnished with these data, and having regard to the known qualities of the completed ships, it is possible to secure similar, or perhaps improved, performance in the new design. Apart from such experience, however, the naval architect would be unable to be equally certain of obtaining good results; and in cases where great strides are taken in a new design, away from the sizes and proportions or sail plans of existing ships, the arrangement of the sail-power cannot but be, to a large extent, experimental. Illustrations of this are to be found in the earlier ironclads of the Royal Navy, such as the *Achilles* and *Minotaur* classes, in which the sizes, lengths, and proportions of length to

breadth were all much greater than in preceding ships. When first fitted with four masts, the *Achilles* did not perform well under sail; but as now arranged with three masts, she stands high among the ironclads. The *Warrior*, on the other hand, a ship of the same class as the *Achilles*, proved successful under sail from the first; having only three masts. In fact, although the general principles of propulsion by sails were long ago formulated, and although many eminent mathematicians and naval officers have endeavoured to assist the naval architect by constructing general rules for guidance, there is even now no accepted theory fully representing the conditions of practice. In this chapter attention will be confined to a few of the fundamental principles of propulsion by sails, and to the simple rules which are commonly observed by naval architects in arranging the sails of a ship.

It will be evident that accurate investigation of the behaviour of sailing ships must depend greatly upon correct knowledge as to the laws which govern the pressure of wind on the sails. Most of the data available are due to the labours of French experimentalists. Colonel Beaufoy made a few experiments on air resistance, and the late Mr. Froude gave some attention to the subject, but was prevented from pursuing it by the pressure of other work.* Of late years, special attention has been drawn to the laws of wind pressure on railway structures in consequence of the Tay Bridge disaster, and a mass of information has been collected.

In the following table a summary is given of the results of experiments made with *thin plates*, placed normal to the line of motion of the air relatively to their plane surfaces. If

A = area in square feet of plane surface of plate,

V = the relative velocity of the wind and the plate, in feet, per second,

R = pressure on plate (or air resistance), in pounds,

then it is found from experiments with small plates that

$$R = k \cdot A \cdot V^2,$$

where k is a constant coefficient.

* An excellent summary of the French experiments is given in Spon's *Dictionary of Engineering*. Beaufoy's experiments are mentioned in the *Papers on Naval Architecture*, vol. i. The details of Lieutenant Paris's ex-

periments will be found in vol. xxxi. of the *Revue Maritime et Coloniale*. For the details of recent observations on wind pressures, see *Parliamentary Paper* (C 3000) of 1881.

Of all the experiments on thin plates those of Mr. Froude were made under the conditions most favourable to exactness, practically uniform motion having been secured. The experiments of Morin and Didion were made with delicate chronometric apparatus, and nearly agree with Mr. Froude's result. The observations of Lieutenant Paris were carefully conducted, but having been made on board ship were necessarily subjected to many disturbing causes, besides which, any accurate determination of the relative velocity of the wind and the plate could scarcely be hoped for under the circumstances. On the whole, therefore, the value of k given by Mr. Froude is to be preferred, and if it is accepted, a pressure of one pound per square foot corresponds to a relative velocity of about $14\frac{1}{2}$ knots per hour— $24\frac{1}{4}$ feet per second.

Experimentalist.	Date.	Value of k .	Mode of Experiment.
Borda . . .	1763	·00184	Plates moved through still air on a revolving fan-wheel.
Thibault . .	1832	·00206	
Morin } . .	{ 1835 to 1837	·0019	
and Didion } . .		·0016	Plate falling vertically.
Rouse	·00229	Plate exposed to actual wind on board ship. Plate moved through still air.
Hutton.	·00188	
Paris . . .	1872	·00239	
Froude. . .	1876	·0017	

It is necessary to add that the experiments above-mentioned were made on small plates, not exceeding three or four square feet in area; and that there is no evidence to show that the same coefficients connecting pressure (per unit of area) and velocity, hold for large plane areas as have been found to hold good for small areas.

The report of the committee appointed by the Board of Trade to consider the wind pressure on railway structures gives the results of a great number of observations made with anemometers, and proposes a formula for connecting velocity and pressure based upon these observations. This formula is

$$P = \cdot 01 V^2.$$

Where P = the maximum pressure, in pounds on the square foot, occurring during the storm to which V refers.

V = the maximum run (in miles) of the wind in any one hour.

This formula would give a value P of 1 lb. per square foot, for a velocity of only ten miles per hour, or $14\frac{2}{3}$ feet per second, which will be seen to differ widely from the results given above for experiments made on small plates. But it will also be remarked that the results are not strictly comparable; because, in the first-named experiments, the pressure is expressed in terms of a uniform velocity, whereas in the anemometric observations the velocity is the "maximum hourly run," and the pressure is the "maximum pressure" likely to be experienced during the hour. In other words, the wind has a varying velocity, alternating above and below the average for the hour, and the proposed formula allows for this variation. If it be assumed that the two sets of observations are practically correct, then it follows that the maximum velocity of the wind during an hour's run is likely to exceed the average velocity by about 65 per cent. All these anemometric observations were made on comparatively small pressure plates; and there is no evidence to show that the formula recommended for use is strictly applicable to large areas of varied forms.

Passing from the simplest case of normal impact to that where the wind impinges obliquely on a plane surface, we find a still more uncertain state of knowledge. The most elaborate experiments on oblique impact were made by Thibault; and in Fig. 122*a* the results are graphically recorded. Abscissæ

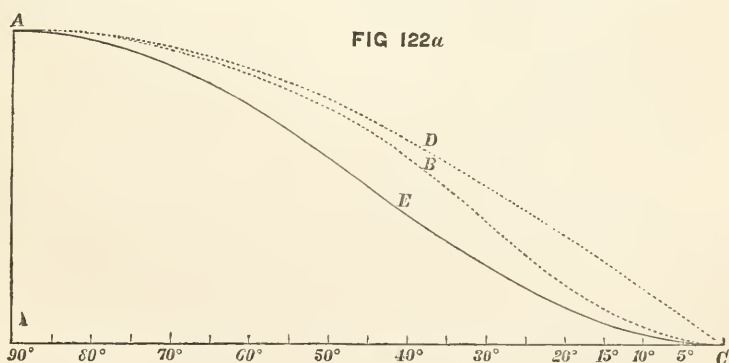

measurements correspond to values of the angle of incidence of the wind on a plane; ordinate measurements indicate the values of the normal pressures. The curve ABC shows Thibault's experimental data: the curve ADC shows what the normal pressure would be if it varied directly as the sine of the angle of incidence: the curve AEC shows what it would be if it varied

as the square of the sine of that angle. Up to angles of incidence of 50 to 60 degrees the curves ABC and ADC are very close to one another: this range corresponds to the case of rolling discussed on pages 169 and 245. For angles of incidence below 30 degrees such as occur in ships sailing "close-hauled" (see page 486), the experimental curve is intermediate between the other two. These experiments of Thibault were also made on small planes.

When we pass from plane surfaces to sails, we are in still more doubt as to the laws of wind pressure. The only experiment we have been able to trace was made by Thibault about half a century ago. He attached small sails (about 1.2 square foot in area) to the arms of a fan-wheel, and noted the resistances when the sails were tightly stretched as planes, and when they bellied out under the action of the air. His conclusion from these small-scale experiments was very interesting, although it can scarcely be regarded as certainly applicable to the enormously greater areas of the sails in a large ship. It was that the normal pressure on the curved sail was equal to that on a plane sail of equal area; the effect of the curvature counterbalancing the reduction of the area when projected on a plane normal to the wind. But experience appears to show that the more nearly plane the surface of a sail can be kept, the greater will be the propelling force derived from the wind pressure upon it. "All slack canvas," says Mr. Fincham, "whether sailing by the wind or large, lessens the effect of the sail; and even before the wind, when the slack reef is out the power which acts on the sail will be reduced very considerably on the curved surface; less even than the base of the same curve, or than if the sail were set taut-up, but reduced to the same hoist or distance between the yards as when slack." Up to the present time, therefore, accurate knowledge is almost entirely wanting respecting the laws which govern wind pressures on large sails. We cannot certainly express the pressure per unit of area on large sails corresponding to a given velocity of wind and to a certain angle of incidence; and need further experiments on a larger scale, accompanied with more accurate observations than are now common, respecting the velocity and pressure (on small planes) of the wind. Such experiments would be by no means difficult to arrange, and they could be best conducted on board small sailing vessels, such as yachts, of which the stability had been ascertained by experiment and calculation. It would be necessary to place the vessel beam-on to the wind, to hoist certain sails, and to note the corresponding angles of steady heel. By means of anemometers the velocity

and pressure (on small areas) could be measured simultaneously; and the total pressure per unit of area on the sail set could be deduced from the righting moment due to the observed angle of heel. The areas and forms of the sails set could be varied, and thus much valuable information could be obtained.

Before leaving this subject a brief statement may be added respecting the ordinary classification of winds. Authorities agree in assigning a speed of from 60 to 100 knots per hour to a hurricane (Force 12). Accepting the coefficient deduced from small thin plates the pressure corresponding to these velocities would be from 18 to 50 lbs. per square foot. The "storm-wind" (Force 11) would have a speed of 45 to 50 knots, and a pressure of from 11 to 13 lbs.; the "heavy gale" (Force 10) would have a speed of about 40 knots, and a pressure of 8 to 9 lbs.; the "strong gale" (Force 9) a speed of about 34 knots, and a pressure of 6 lbs.; the "fresh gale" (Force 8) a speed of about 28 knots, and a pressure of about 4 lbs.; the "moderate gale" (Force 7) a speed of about 23 knots, and a pressure of $2\frac{3}{4}$ lbs.; the "strong breeze" (Force 6) a speed from 15 to 20 knots, with a pressure from 1 lb. to 2 lbs.; and the "fresh breeze" (Force 5) the upper limit of 1 lb. pressure, corresponding to a speed of 14 knots as above. All these pressures are supposed to act on a plane area of one square foot placed at right angles to the direction of the wind.

If the speeds of wind given above are taken to mean "hourly runs," and the approximate formula of the Board of Trade Committee is used for estimating maximum pressure, then the "hurricane" would correspond to maximum pressures of 48 to 130 lbs. per square foot, and all the other pressures just named would be proportionately increased (about $2\frac{3}{4}$ times). From the report of this Committee it appears that, under exceptional circumstances, pressures of 80 to 90 lbs. per square foot have been noted in this country; but from 50 to 60 lbs. are unusually high pressures, and the Committee recommended that 56 lbs. per square foot should be taken as a maximum wind pressure in calculations for railway bridges and viaducts.

Sails attached to ships are not fixed in position like the planes and sails considered above, but necessarily move with the ship. Hence, in dealing with the propulsive effect of a wind of which the absolute direction and force are known, it is necessary to take account also of the motion of the ship; or, as it is usually expressed, it is necessary to determine the *apparent* direction and velocity of the wind. This can be done easily in any case

for which the course and speed of the ship, as well as the true direction and velocity of the wind, are known; the simple general principle being that the apparent motion of the wind is the resultant of the actual motion of the wind, and a motion equal and opposite to that of the ship. A vane at the mast-head would indicate the apparent direction of the wind, and not its true direction; an anemometer on board would measure the apparent velocity of the wind.

Take the simplest case: a vessel with a single square sail running "dead before" the wind. If the speed of the wind is V feet per second, and that of the ship v , as the direction of both motions is identical, the resultant of the actual speed of the wind and the reversed motion of the wind will be $V - v$ feet; and this apparent motion will govern the propulsive effect. For example, let the speed of the wind be 15 feet per second; that of the ship 5 feet per second; the apparent speed of the wind will be 10 feet ($15 - 5$); and, accepting the coefficient given above for normal impact on small planes, the pressure per square foot of area of sail will be given by the equation:—

$$\text{Pressure} = \frac{17}{10000} \times 10^2 = \frac{17}{100} \text{ lb.}$$

The pressure of this wind on a *fixed* sail would be about $2\frac{1}{4}$ times as great. From this simple illustration it will be seen that it is most important to determine accurately the apparent motion of the wind.

As a second illustration, take the case of a vessel sailing on a wind close-hauled, with the wind *before* the beam. To simplify matters, let a single square sail be considered set on the yard

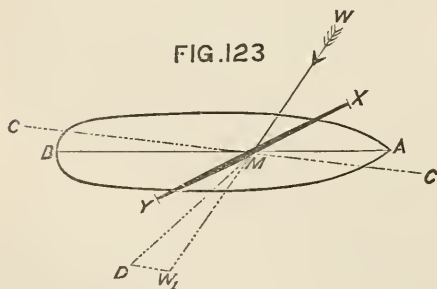

marked XY in Fig. 123.

AB represents the middle line of the ship, the outline of the "plan" being indicated. The line WW₁ represents the *actual* direction of the wind; let MW₁ represent (on a certain scale of feet) its velocity. The line CC shows the course of the ship;

and on W₁D (which is drawn parallel to CC) a length W₁D is set off to represent a motion equal and opposite to that of the ship, the same scale being used for W₁D as was

employed for the length MW_1 . Join MD ; then MD represents in magnitude and direction the apparent velocity of the wind. MD is *greater* than the actual velocity MW_1 ; but its direction makes a *more acute angle* with the sail on XY than does the actual direction WW_1 .

The case of a ship sailing with the wind abaft the beam is illustrated in Fig. 124; the reference letters being similar to those in Fig. 123, no description is needed. Here the resultant MD is *less* than the actual velocity MW_1 ; but, as in the previous case, it makes a more acute angle with the sail on XY .

With these two examples before him, the reader will have no difficulty in readily determining the apparent velocity and direction of the wind, corresponding to observed actual speeds and directions of the wind, and observed speeds of a ship on a certain course. But this is by no means a complete solution of the question which presents itself in practice, and takes the form:—Given a certain actual direction and speed of wind, and the sail area and angle of bracing for the yards, what will be the course of the ship, and her speed of advance? To answer the question fully and correctly requires *data* beyond those at present possessed; but an approximate solution is possible.

Reverting to the case of a ship sailing on a wind (Fig. 123), suppose the apparent direction and speed of the wind to have been determined; and further suppose the normal pressure on the sail corresponding to this apparent wind to be known. In Fig. 125, let EM represent in magnitude the pressure which the apparent wind would have upon the sail if placed normally to it, the line EM corresponding to MD produced in Fig. 123. The pressure acting along EM may be regarded as the resultant of two components: one (EF) acting parallel to the sail XY , and

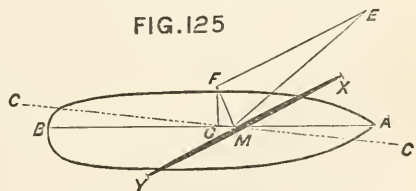
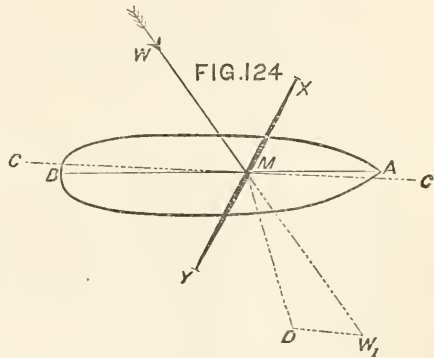

not sensibly affecting it; the second (FM) acting normally to the sail. This normal pressure, again, may be regarded as made up of three pressures: one of these (shown by GM) acts longitudinally; the other (FG) acts athwartships, and the third acts vertically, at right angles to the other two, which act horizontally. For moderate angles of steady heel under sail, such as are common in ships, the vertical component of the normal pressure is not of much importance, and it is usually neglected. In all cases, however, it tends to increase the immersion of a ship; and in some cases, when the angle of heel is considerable, this effect may be noteworthy. Let it be assumed for the present that only the horizontal components FG and GM require to be considered.

When the motion of the vessel has become uniform under the action of a wind of constant force and unchanging direction, it will take place along some line, such as CC, lying obliquely to her middle line AB. This motion may be resolved into two parts: one, a direct advance, in the line AB, the other a drift to leeward perpendicularly to AB. The angle made by the line CC with the keel-line AB, is called the "angle of leeway." Its magnitude depends upon the ratio of the velocity of advance, or headway, along AB to the velocity of drift or leeway, and these velocities are governed by varying conditions.

If a ship were running before the wind there would be no leeway, and her motion would closely resemble that described in the previous chapter, the effective wind pressure taking the place of the tow-rope, but being applied at a considerable height. Hence, when the motion has become uniform, the wind pressure will be opposed by an equal and opposite fluid resistance, and these forces will form a mechanical couple tending to change the trim, as was previously explained. The actual change of trim would, however, be small in most cases. For instance, in the *Greyhound* running dead before the wind at a speed of 6 knots, the resistance would be about $1\frac{1}{2}$ tons, the moment of the couple less than 100 foot-tons, and the change of trim less than one inch.

As a second extreme case, suppose a ship to have her sails braced fore-and-aft, with wind abeam, and to drift bodily to leeward, moving parallel to her original position, and making no headway. When uniform speed of drift had been obtained, a lateral resistance would be developed equal and opposite to the effective wind pressure, and forming with it a mechanical couple causing the ship to heel. This lateral resistance, for a given speed of drift, is obviously much greater than the resistance to headway at the same speed. The ratio of the two

resistances may vary greatly in different classes of ships; on account of differences in form or draught, or in the areas of keels, deadwoods, and other approximately flat surfaces immersed. Such surfaces experience a lateral resistance resembling that offered to plane surfaces moving parallel to themselves, and are, therefore, very effective in checking leeway. The curved and approximately cylindrical portions of the bottom of a ship permit the particles of water to glide past them with less abrupt changes of motion, and therefore contribute less to the lateral resistance. Exact measures of that resistance have not been determined, similar to the measures for head-resistance described in the preceding chapter. Speaking generally, it is necessary for efficiency under sail, and weatherliness, that there should be considerable lateral resistance; and in some classes of ships various devices are employed in order to increase the lateral resistance, and to diminish leeway. In shallow-draught or flat-bottomed vessels, "lee-boards" are often fitted; these boards can be dropped at the sides of the vessels, and made to project beyond the bottom. Sliding keels, or "centre-boards," are sometimes fitted so as to be housed in recesses formed within the vessels, or to be lowered below the bottom. Very deep keels and great rise of floor are also commonly adopted in yachts designed for racing, for the same purpose.

A rough approximation is sometimes used for comparing the lateral resistances of ships of similar form; by assuming that those resistances are proportional to the resistances which would be experienced by the immersed parts of their longitudinal middle-line planes, if they were moved to leeward at certain speeds. It need hardly be stated that this method of procedure can only be applied within the limits named: because two ships having the same area of middle-line plane might differ greatly in fineness of form, areas of keel, &c., and so have very different lateral resistances. A more trustworthy method of estimation consists in finding the aggregate areas of the keels, deadwoods and other approximately flat surfaces, and calculating their resistances by Beaufoy's formula, given on page 436; while the remaining portions of the wetted surface would have their resistances estimated according to the formula for frictional resistance on page 438. But even this mode of estimating lateral resistance can be treated only as fairly approximate, not as exact.

The conditions of actual practice in sailing ships lie between the two hypothetical cases, above described, of no leeway and no

headway. A sailing ship proceeding at uniform speed under certain conditions of wind and sail-spread, usually follows a course making an angle of leeway with her keel-line, and in doing so both heels and changes trim. From what has been said above it will be seen that *a priori* estimates of the angle of leeway for a given ship and a certain set of conditions cannot be made with certainty. Experience shows that in successful ships the angle of leeway is seldom much more than 6 degrees and rarely exceeds 12 degrees; in less successful ships, or shallow-draught vessels with no drop-keels, the angle of leeway may be much greater.

The tangent of the angle of leeway (AMC, in Fig. 125) equals the ratio of the speed of drift to the speed ahead. These speeds depend upon various conditions, some of which have been mentioned. It will be evident for example, that variations in the angle (AMX) to which the yards are braced will affect both the absolute and the relative values of the transverse and longitudinal components of the wind pressure. If the normal pressure (FM) were known, we should have—

$$\frac{\text{Transverse pressure}}{\text{Longitudinal pressure}} = \frac{FG}{GM} = \cot \text{AMX}.$$

Suppose AMX = 30 degrees: then

$$\text{Transverse pressure} = \text{longitudinal pressure} \sqrt{3}.$$

The speeds ahead and to leeward clearly do not depend simply upon this ratio of the longitudinal to the transverse wind pressures; they are governed far more by the relative resistances of the water to the motion of the ship ahead and to leeward. Even if the two pressures were exactly equal, the resistance to leeway would be much greater than the resistance to headway, and the speed of advance would much exceed the speed of drift. Moreover it must be noted that the magnitude and direction of the fluid resistance are affected by the action of the wind upon the sails. Heeling destroys that symmetry of form in the immersed part of the ship which exists when she is upright; and thus the character of the stream-line motions is changed from that considered in the preceding chapter. Change of trim may also affect the resistance somewhat, but probably not to so serious an extent as heeling. Leeway, again, causes the vessel to move obliquely through the water, instead of along her line of keel; and this oblique motion not merely involves additional resistance, but leads to an unequal distribution of the dynamical pressures on the leeward side. The most intense pressures are experienced on the lee bow, and this effect is

enhanced by the heeling; so that the tendency is to make the bow "fly up into the wind." From this brief statement it will appear, therefore, that any exact determination of the speed and course as well as magnitude and direction of the fluid resistance experienced by a sailing ship is scarcely to be hoped for; even when the force and direction of the wind, the spread of sail and bracing of the yards, are assumed to be given. But it will also be obvious that in every case when uniform motion has been attained on a certain course the longitudinal and transverse components of the fluid resistance will balance respectively the corresponding components of the effective wind pressure.

Confining attention for the moment to the longitudinal components, it will be evident that if the component of the effective wind pressure exceeds the corresponding component of the resistance, the velocity of headway will be accelerated. Reverting to Figs. 123 and 125 it will be seen that the increase in speed must affect both the direction and velocity of the apparent wind, and so influence the value of the longitudinal component of the effective wind pressure. But so long as GM, Fig. 125, exceeds the longitudinal component of the resistance so long will the speed be increased. If the resistance is small even at very high speeds, then it is theoretically possible for a vessel sailing on a wind to attain a speed exceeding that of the wind. In ice boats this condition is realised. There is practically no leeway, and the frictional resistance of the sledge or "runner" on which the boats run is exceedingly small even at high speed. With the wind varying from a point before the beam to an equal amount abaft the beam speeds are said to have been reached about equal to twice the real velocity of the wind.

When a ship, sailing at a uniform speed, under the action of a wind of which the force and direction are constant, maintains an unchanged course without the use of the rudder, it is clear that the resultant pressure of the wind on the sails and the resultant resistance of the water cannot form a couple tending to turn the vessel. Under these circumstances, therefore, these equal and opposite forces must act in the same vertical plane. If it were possible to determine the line of action of the resultant resistance for any assumed speed, on a certain course in relation to the direction of the wind, then it would follow that the sails should be so trimmed as to bring the line of action of the resultant wind pressure into the same vertical plane with the resultant resistance, if the course is to be maintained without the use of the rudder. The less the rudder is used in maintaining the course, the less

will the speed of the ship be checked thereby. In practice, however, the theoretical conditions cannot be fulfilled, because the line of action of the resultant resistance cannot be determined in the present state of our knowledge, even under given conditions of speed and course; because that line of action changes its position with changes in the speed, the angle of leeway, and the transverse inclination of the ship, not to mention the changes consequent on the alterations in the force and direction of the wind; and because it is not possible to determine accurately the line of action of the resultant wind pressure on the sails, when set in any given position. The problem which thus baffles theory is, however, solved more or less completely in practice; the skilful seaman varies the spread and adjustment of his sails in order to meet the changes in the line of action of the resistance. In a well-designed vessel, the distribution of the sail is such that the commanding officer has sufficient control over her movements under all circumstances. Some vessels, however, are not so well arranged for sailing purposes, and in them "ardency" or "slackness" when sailing on a wind may be practically incurable.

"Ardency" is the term applied when a vessel tends to bring her head up to the wind, and she can only be kept on her course by keeping the helm a-weather; the resultant resistance must then act before the resultant wind pressure. The contrary condition, where the resultant resistance acts abaft the resultant wind pressure, and makes the head of the ship fall off from the wind, is termed "slackness," and can only be counteracted by keeping the helm a-lee. Of the two faults, slackness appears the more serious; for a vessel thus affected seldom proves weatherly. To avoid excess in either direction, the naval architect distributes the sails of a new ship, in the longitudinal sense, by comparison with the arrangements in tried and successful vessels, conforming to some simple rules which will be stated hereafter.

From the foregoing explanations it will appear that the greatest care must be taken in determining the angle to which the yards shall be braced, or the sails set, in order to secure the greatest speed when sailing on a wind. This is pre-eminently a question of seamanship; but it has engaged the attention of many eminent mathematicians, whose investigations still remain on record. All these investigations were based upon certain assumptions, as to the effective pressure of a wind acting obliquely upon the sails, the apparent direction and velocity of that wind being known. In Fig. 125, for example, if EM represents in direction and magnitude the "pressure due to the apparent velocity" of the

wind—that is, the pressure it would deliver upon a plane area, say, of one square foot placed at right angles to EM—the effective pressure (FM) would, according to the law formerly received, have been expressed by $EM \sin^2 EMX$. It has been shown that this law cannot be accepted; and therefore the elaborate deductions which have been made from investigations based upon it have now little interest. Even if the true law were determined, mathematical inquiries could never be trusted to replace the judgment of the sailor in determining the most efficient angle for bracing the yards or trimming the sails. So many varying circumstances have to be encountered in the navigation of a sailing vessel that theory can never be expected to take complete cognisance of them all. The decision as to the best mode of handling a sailing ship must always rest, where it has always rested, in the hands of her commander. One thing, however, is obvious from the preceding remarks, viz., that it is a very great advantage to a ship in sailing close-hauled to be able to brace her yards up very sharply, in order to secure the most advantageous angle of incidence (EMX, Fig. 125) of the wind upon the sails, and thereby render the propelling force as great as possible under the circumstances. In this respect, square-rigged vessels compare unfavourably with fore-and-aft-rigged vessels, the shrouds, stays, &c., imposing serious limitations upon the bracing of the yards. After bringing together and digesting a great mass of facts respecting sailing ships, Mr. Fincham summed up this matter as follows:—“When close-hauled, experience has shown that the yards in square-rigged vessels can seldom be braced sufficiently sharp to obtain the most advantageous position for plying to windward.” He also gave from 13 to 17 degrees with the keel as the angles which the “feet” of the sails of a fore-and-aft-rigged vessel seldom exceed on a wind, such angles being less than can be reached in all, or nearly all, square-rigged vessels. In yachts the corresponding angles are said to seldom exceed 10 degrees. It must be observed, however, that in all fore-and-aft-rigged vessels there is a sensible difference in the angle at the head and foot of a sail. For all the sails except those set on a stay, such as foresail or jib, the angle at the foot is less than that at the head: for sails set on a stay the converse may hold good.

Passing from these general considerations respecting propulsion by sails to the practical problems which the naval architect has to solve in determining the sail-spread appropriate

to any new design, it becomes necessary to note an important distinction. In all his calculations the naval architect is accustomed to deal only with *plain sail* or *working sail*, and not to include all the sails with which a ship may be furnished. Plain sail may be defined as that which would be commonly set in a fresh breeze (Force 5 to 6), which is usually assumed to correspond to a pressure of about 1 lb. per square foot of canvas. The following tabular statement shows concisely what sails would generally be included in the plain sail of various classes of ships; and although the sails not included are of value, especially in light winds, yet it will be obvious that those named in the table are very much more important.

Style of Rig.	Plain Sail.
Ship . .	Jib, fore and main courses, driver, three topsails, and three top-gallant sails.
Barque . .	As ship, except gaff-topsail on mizen-mast.
Brig . . .	As ship, exclusive of mizen-mast.
Schooner .	Jib, fore stay-sail, fore-sail, and main-sail.
Cutter . .	Jib, foresail, and main-sail.

Notes to Table.

In brigs, one half the main course and the driver are sometimes taken instead of the whole of the main course.

In schooners, the fore-topsail is sometimes included.

In yawls, besides the sails named for cutters, the gaff-sail on the mizen is included.

It will be understood in what follows that, except in any cases specially mentioned, we are dealing only with plain sail, and not with total sail area.

In arranging the plan of sails for a new ship, the naval architect has to consider three things: (1) the determination of the total sail-spread; (2) the proper distribution of this sail in the longitudinal sense, including the adjustment of the stations for the masts; (3) the proper distribution of the sail in the vertical sense, in order that the vessel may have sufficient stiffness. On each of these points we now propose to make a few remarks, taking them in the order they have been named.

First: as to the determination of the *total area* of plain sail in new design.

Other things being equal, the propelling effect of the sails of a ship depends upon their *aggregate area*. Wind pressure and the management of ships are necessarily varying quantities. Hence

for equal speeds the area of plain sail in two ships should be made proportional to their respective resistances at those speeds. For speeds such as are ordinarily attained under sail it appears not unreasonable to assume that frictional resistance furnishes by far the larger portion of the total resistance; and when the bottoms of two ships are equally rough—having the same coefficient of friction—the frictional resistances will be proportional to the immersed or “wetted” surfaces of the bottoms. Further, if the two ships are similar in form, but of different dimensions, the wetted surfaces will be proportional to the *two-thirds* power of their displacements; for these surfaces will be proportional to the *squares* of any leading dimension—say the length—while the displacements will be proportional to the *cubes* of the same dimensions. Put in algebraical language, if W_1 be the displacement of one ship, S_1 the wetted surface, and A_1 the area of plain sail; while W_2 , S_2 , and A_2 are the corresponding quantities for another similarly formed ship: then for equal speeds under sail we must have,

$$\frac{S_1}{S_2} = \frac{A_1}{A_2} = \left(\frac{W_1}{W_2}\right)^{\frac{2}{3}}$$

Suppose, for example that, $W_1 = 8W_2$; then

$$\frac{A_1}{A_2} = \left(\frac{8W_2}{W_2}\right)^{\frac{2}{3}} = 8^{\frac{2}{3}} = 4; \text{ or, } A_1 = 4A_2.$$

Although the attainment of a given speed under certain conditions does not form part of the design of a sailing ship, as it does in a steamship, yet it may be interesting to notice in passing a roughly approximate method for determining the sail-spread of a new ship when it is desired to give her greater speed than that of the typical ship or ships used as examples. Let it be assumed, as may be fairly done, that the resistance of these ships varies as the square of the speeds, within the limits of speed considered. Further let it be assumed that the effective pressure (per square foot) of the wind on the sails is the same for both ships.* Then, if V_1 and V_2 be the maximum speeds, and the other notation remains as before, we have,

* This latter assumption is not strictly correct; since the difference in speed must produce some difference in the apparent direction and velocity

of the wind. The character of the correction required will be understood from the remarks previously made (page 486).

$$A_1 = k (W_1)^{\frac{2}{3}} \times V_1^2,$$

$$A_2 = k (W_2)^{\frac{2}{3}} \times V_2^2,$$

where k is a constant, and the same for both ships. Hence

$$\frac{A_1}{A_2} = \left(\frac{V_1}{V_2}\right)^2 \times \left(\frac{W_1}{W_2}\right)^{\frac{2}{3}}$$

is an equation from which the new sail-spread (A_2) may be determined approximately; but for the reasons given above it has little practical value.

Keeping to the ordinary assumption that equality of speed is aimed at in the new and old sailing ships compared, it would no doubt be preferable when arranging the sail-spread of a new ship differing considerably in form from the exemplar ship to determine the resistances by model experiments, and then to proportion the sail-areas to those resistances. But this has never yet been done, and it is never likely to be done with a view to influencing practice, seeing that steam propulsion is gaining so much on propulsion by sails. On the whole, the equation on the previous page, although obtained under the limitations stated, is found a sufficient guide in most cases, when comparing the sail-power of ships not similar in form, provided the dissimilarity is not very great. For some years past it has been usual in the Royal Navy to compare the "driving powers" of the sails in different ships by the ratio—

$$\text{Sail-spread} : (\text{Displacement})^{\frac{2}{3}}.$$

But it is fully recognized that if there is considerable difference in form, it would be preferable to use the ratio—

$$\text{Sail-spread} : \text{Wetted Surface}.$$

It may happen that when the equation on page 495 is used to determine the sail-spread for a new ship, it gives results which are inadmissible. For example, a ship may not have sufficient stability to carry the sail-area which the formula would assign to her: or it may be impossible to find room for the efficient working of the theoretical sail-spread. This statement is tantamount to another, which is fully borne out by experience, viz. that in ships of different types and sizes, different "driving powers" of sail have to be accepted, and the hypothetical condition of equal speeds is abandoned.

Formerly it was the practice to proportion the area of plain

sail to the *area of the water-line section* of ships; and this would agree with the foregoing rule so long as the condition of similarity of form was strictly fulfilled. But, when the vessels compared are somewhat dissimilar in form and proportions, it becomes preferable to express the sail-area as a multiple of (displacement) ^{$\frac{2}{3}$} rather than as a multiple of the area of the water-line section. Very similar remarks apply to another method once commonly used, in which the area of plain sail was proportioned to the area of the *immersed midship section*; a plan which was applicable only when the vessels compared were similarly formed. Still another method of stating the sail-spread is to express it as a multiple of the displacement (in tons). A ship of 3500 tons displacement with 24,500 square feet of plain sail would be described as having 7 square feet of canvas per ton of displacement. It will be obvious from the explanations given above that, if anything like a constant ratio of sail-area to displacement is maintained, the large ships would have been much superior to the smaller in driving power and speed. Hence it was the practice, in former times, to increase the ratio greatly as ships diminished in size; so that the smaller classes might be as fast as, or faster than, the larger. This practice still holds good, in yachts and vessels designed to perform well under sail; as size is diminished the sail-spread is made proportionately greater, and the consequent risks are accepted, because it is recognised that the smallness of individual sails make them easily handled.

A full statement of the sail-spread considered desirable in different classes of ships would occupy space far exceeding the limits at our disposal.* The treatise on *Masting Ships* published some years ago by Mr. Fincham contains detailed information on the subject that can still be studied with advantage, embracing, as it does, not merely the particulars of sailing ships of all classes, but also those of the classes of unarmoured steamships of the Royal Navy designed before the ironclad reconstruction began. In this work the area

* For the facts as to merchant ships given hereafter, the Author has chiefly to thank Mr. John Ferguson (of Messrs. Barclay, Curle & Co.) and Mr. Bernard Waymouth (Secretary of Lloyd's Register). From the "*Report*

on *Masting*," made by Lloyd's surveyors, he has also obtained valuable *data*. For the facts as to yachts, he is almost entirely indebted to the works of Mr. Dixon Kemp.

of plain sail is expressed as a multiple of the area of the water-line section, and the following figures may be interesting. For ship-rigged vessels the area of plain sail is said to have been from 3 to 4 times the water-line area; for brigs and schooners from $3\frac{1}{2}$ to $3\frac{3}{4}$ times, and for cutters from 3 to $3\frac{1}{2}$ times. These ratios were for sailing vessels; in their unarmoured successors, possessing both steam and sail power, the ratio is not so high, and in a great many ship-rigged vessels falls to 2 or 3. In yachts of the present day the ratio varies from $3\frac{1}{2}$ to $5\frac{1}{2}$, $4\frac{1}{2}$ being a common value in vessels having a great reputation for speed. In the armoured ships of the Royal Navy the corresponding ratio is in some cases a little above and in others a little below 2. In sailing ships of the mercantile marine the corresponding ratio has been found to vary from $2\frac{1}{4}$ to 3 in a large number of examples, $2\frac{1}{2}$ being a good average; but this mode of measuring the sail-spread is not commonly employed by private shipbuilders.

Taking the ratio of sail-spread to area of immersed midship section, it appears that in the obsolete classes of sailing war-ships this ratio varies from 25 to 30 in line-of-battle ships, up to 30 to 45 in frigates, and 40 to 50 in brigs and small craft. This is the mode of measurement still commonly used in the French navy, and M. Bertin thus summarises their practice. In the obsolete sailing line-of-battle ships the ratio was from 30 to 35, in frigates 35 to 40, for smaller classes sometimes as high as 50. In the unarmoured ships, with steam and sail, the French practice has given ratios of sail-spread to midship section, varying from 28 in line-of-battle ships to 40 in frigates and cruisers. In the French ironclads the ratio has not exceeded 20. For English ironclads, equipped for sailing, the ratio varies from 18 to 25; for unarmoured frigates of the older classes it is about 32, and for the swift cruisers 26. For corvettes and sloops the corresponding ratios are 23 to 33. For sailing ships of the mercantile marine the ratio varies from 22 to 35 in a great number of ships examined, about 28 being a good average value. For racing yachts the ratio varies greatly—from 50 to 70 in English yachts, and exceeding 80 in American yachts of the broad shallow type.

The ratio of sail-spread to displacement is not commonly used for war-ships or yachts, but is frequently employed for merchant ships. It is unnecessary to repeat the remarks made above as to the limitations within which this mode of

measurement can be usefully employed. In a considerable number of sailing merchantmen of modern design this ratio has been found to vary from $4\frac{1}{2}$ to 8, the largest ratio occurring in the ships of least displacement. For ships below 2000 tons displacement, $6\frac{1}{2}$ is a good average value; for larger ships up to 4000 tons displacement $5\frac{1}{2}$ to 6 is a fair value. Simply as a matter of comparison it may be stated that in the obsolete classes of sailing men-of-war the ratio of sail-spread to displacement varied from about 6 in the largest classes (4000 to 5000 tons displacement) up to 12 or 15 in frigates (of 1200 to 2000 tons displacement), and 20 to 30 in the brigs and small craft. For racing yachts the corresponding ratio varies from 30 in a yacht of 300 tons displacement up to 60 in one of 30 tons. For the unarmoured ships of the Royal Navy, having steam as well as sail power, the ratio is about 5 to 7 for frigates, 5 to 6 for corvettes, and 9 to 12 for sloops. For the unarmoured ships it commonly varies between 3 and 4, rising to 6 in a few of the smallest vessels.

Another mode of comparing sail-spreads occasionally used in the mercantile marine is to express the ratio of the sail-spread to the under-deck tonnage. For ships of similar class (as explained in Chapter II.) this tonnage bears a fairly constant ratio to the displacement at the deep load-line. Hence the practice now being described is open to the same objections as were urged against the preceding method. From 12 to 16 are common ranges in the ratio of sail-spread to under-deck tonnage, and 13 is a good average in ships of moderate size.

Comparing these various classes by the ratio which the sail-spread bears to the two-thirds power of the displacement, the following results may be interesting. The numbers represent, for some typical ships of war, the quotient:—

$$\text{Sail-spread} \div (\text{displacement})^{\frac{2}{3}}$$

SAILING:—	STEAM:—
Line-of-battle ships 100 to 120	Ironclad ships 60 to 80
Frigates } 120 to 160	Unarmoured:
Corvettes }	Frigates } 80 to 120
Brigs }	Corvettes }
	Sloops }

It will be remarked that the proportionate sail-power of the steam unarmoured frigates, &c., is, on the whole, less than that of the sailing vessels, and that the armoured ships stand still lower in the scale. But it must be noticed that some of the steamships

have finer forms and proportions than the sailing ships, so that their resistances may be proportionately less. Further, it is important to note that the great increase in displacement which has accompanied the construction of ironclads renders it practically impossible to give to these heavy vessels a spread of sail comparable in propelling effect to that of the sailing line-of-battle ships, even if other and more important qualities were sacrificed. Take, for example, the 80-gun sailing line-of-battle ship *Vanquard*, with a displacement of 3760 tons and sail-spread of 28,100 square feet. Here the quotient sail-spread \div (displacement) ^{$\frac{2}{3}$} is not much below 120; in the best of the completed ironclads built for distant services—the *Invincible* class—the corresponding quotient is about 75, and in most of the heavier ironclads it is still less. If the *Hercules*, of over 8800 tons displacement, were furnished with a sail-power proportioned to that of the 80-gun ship, her total area of plain sail would have to be made nearly 50,000 square feet, the actual area being less than 29,000 square feet. After careful investigation, Mr. Barnaby reported as follows:—"It is impossible to obtain so much sail by any multiplication of the number of masts without making them much loftier, unless they were placed so close together as to allow the yards, when braced round, to overlap each other considerably. In this latter case the canvas could scarcely be considered as efficient as in the old ships, and this would involve a further increase upon the area given above."* Without attempting any discussion of the actual sailing qualities of the ironclad fleet, we may therefore conclude that the great size of nearly all the rigged ships renders it unreasonable to expect that they could be made as efficient under sail as were the vessels which depended on sail alone for propulsion. Nor does the progress of the ironclad reconstruction at home and abroad tend in this direction; on the contrary, lighter rigs and less sail-power have been given to the most recent masted types, and some of the most powerful vessels have had no sail-power.

In the mercantile marine the ratio sail-spread to (displacement) ^{$\frac{2}{3}$} is seldom used. An examination of a great number of cases shows this ratio to range from 70 to 110 in vessels of various sizes and types by different builders. Probably 80 to 85 may

* See page 342 of the Appendix to the Report of the Committee on Designs for Ships of War.

be taken as a fair average for ships of moderate size; but the facts stated show that there is no approach to uniformity of practice.

For racing yachts the ratio of sail-spread to the two-thirds power of the displacement has been found to vary from 180 to 200; yachts not designed for racing have ratios from 130 to 180. In the American yacht *Sappho*, of small displacement and great beam, with an enormous sail-spread, the ratio reaches 275. This extreme case leads us naturally to a repetition of the remarks made on page 496 as to the limitations to the use of the ratio as a measure of the driving power. The form of the *Sappho* is very unlike that of the English yachts; hence, instead of using the ordinary formula, it is preferable to actually measure the wetted surfaces and to compare the sail-spreads therewith. If this is done the ratio of sail-spread is found to be about 2.7 for the *Sappho*, nearly the same in several English yachts of large size, and about 2 in other yachts. What is shown to be the fairest comparison here would also be so as between many of the other classes mentioned above, and for exact comparisons between those classes wetted surface should be used.

Secondly: it is important to secure a proper *longitudinal distribution* of the sails, in order that neither excessive ardency nor excessive slackness may result, and that sufficient handiness or manœuvring power under sail may be secured. It has already been shown that the difficulties attending any attempt at a general solution of this problem are insuperable; and we are now concerned only with the methods adopted in practice.

The line of action of the resultant wind pressure changes its position greatly under different conditions: the naval architect therefore starts with certain assumed conditions which are seldom or never realised in service, in order to determine the "centre of effort" of the wind on the sails. All the plain sails are supposed to be braced round into the fore-and-aft position, or plane of the masts, and to be perfectly flat-surfaced. The wind is then assumed to blow perpendicularly to the sails, or broadside-on to the ship, and its resultant pressure is supposed to act perpendicularly to the sails, through the common centre of gravity of their areas. This common centre of gravity is determined by its vertical and longitudinal distance from some lines of reference, those usually chosen being the load water-line, and a line drawn perpendicular to it through the middle point of the length of the load-line, measured from the front of the stem to the back of the

sternpost. Fig. 126 shows a full-rigged vessel with her sails placed as described; the centre of gravity of the area of plain sail or "centre of effort" being marked C. A specimen calculation, illustrating the simple process by which the point C is determined, is appended.

CALCULATION FOR THE CENTRE OF EFFORT OF THE SAILS OF A SHIP.

Sails.	Areas	Distances of Centres of Gravity from Middle of Load-line.		Longitudinal Moment of Sails.		Heights of Centres of Gravity above Load-line.	Vertical Moments of Sails.
		Before.	Abaft.	Before.	Abaft.		
Jib	Sq. ft. 1000	Feet. 145	..	145,000	..	48	48,000
Fore course	2300	85	..	195,500	..	36	82,800
" topsail	2500	83	..	207,500	..	74	185,000
" top-gallant sail.	1100	82	..	90,200	..	108	118,800
Main course	3000	..	20	..	60,000	35	105,000
" topsail	2500	..	23	..	57,500	76	190,000
" top-gallant sail	1100	..	25	..	27,500	110	121,000
Driver	1600	..	120	..	192,000	40	64,000
Mizen topsail	1300	..	100	..	130,000	66	85,800
" top-gallant sail	600	..	103	..	61,800	92	55,200
Total area of plain sail	17,000			638,200	528,800	17,000	1,055,600
				528,800			
						Centre of effort	} 62.1 feet.
				17,000	109,400	above load-line	
Centre of effort before middle of load-line							6.43 feet.
Centre of lateral resistance abaft ditto							6.0 "
Centre of effort before centre of lateral resistance							12.43 feet.

When the centre of effort of the sail-area has been determined relatively to the middle of the load-line, it is usual also to determine the longitudinal position of another point, commonly styled the "centre of lateral resistance." This is marked L in Fig. 126, and is simply the centre of gravity of the immersed portion of the plane of the masts—the same plane area which was referred to in an earlier part of the chapter as considerably influencing the leeway of a ship sailing on a wind. It will, of course, be understood that the point L is no more supposed to determine the true line of action of the resultant resistance than the point C is supposed to determine the line of action of the resultant wind pressure. But, on the other hand, experience proves that the longitudinal distance between the centre of effort C and the centre of lateral resistance L should lie within the limits of certain fractional parts of the length of the load-line.

From the drawings of a ship the position of the centre of lateral resistance may be determined by a very simple calculation; and the particulars required for an approximate calculation are easily obtainable from a ship herself, being the length at the

load-line, draught of water forward and aft, area of rudder, and area of aperture in stern for screw, if the vessel be so constructed.

The distance of the centre of effort before the centre of lateral resistance varies according to the style of rig; and in determining it, regard must be had also to the under-water form of a ship. A full-bowed ship, for example, should have a greater proportionate distance between the two centres than a ship of the same extreme dimensions and draught, but with a finer entrance. In ships trimming considerably by the stern, and with a clean run, the distance between the centres should be made proportionately less. In ship-rigged vessels and barques it appears that the centre of effort is from one-fourteenth to one-thirtieth of the length before the centre of lateral resistance; one-twentieth being a

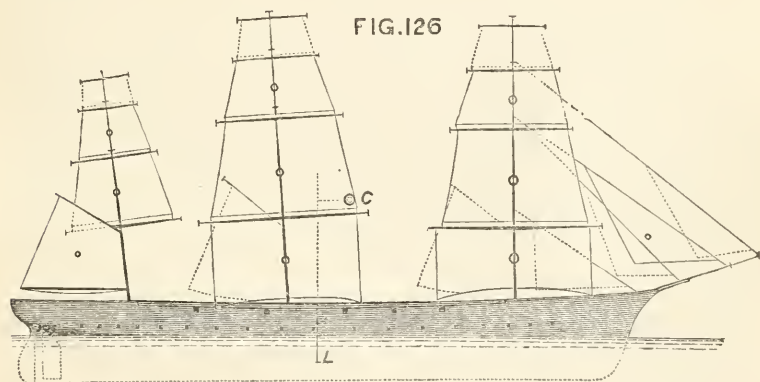

common value. The greater distance (one-fourteenth) occurred in the old sailing ships of the Royal Navy, with full bows and clean runs; this has been almost equalled in some of the later masted ironclads, where the centre of effort has been placed one-sixteenth of the length before the centre of lateral resistance. The smaller distance occurs in screw frigates of high speed and fine form, such as the *Inconstant*; in the unarmoured screw frigates which preceded them, the distance was from one-twentieth to one-twenty-fourth of the length. In brigs, one-twentieth of the length is a fair average for the distance between the two centres. In schooners and cutters, the two centres are always very close together, their relative positions changing in different examples, and the centre of lateral resistance sometimes lying before the

centre of effort. Mr. Dixon Kemp considers that for racing yachts the centre of effort of the sails should be placed about one-fiftieth of the length before the centre of lateral resistance; and for cruising yachts recommends that they should lie in the same vertical line. For yawls the centre of effort should be a little further aft than in cutters or schooners. It is to be noted, however, that in a vessel with square sails the longitudinal position of the centre of effort will vary but very slightly, however wide may be the differences between the angles to which the yards are braced. On the contrary, in a schooner or cutter the centre of gravity of the plain sail must move forward with any angle of departure from the hypothetical position in the plane of the masts.

In the designs of sailing men-of-war, it was formerly the practice to express the longitudinal position of the centre of effort in terms of its distance from the centre of buoyancy; and it was generally agreed that the centre of effort should lie further forward than the centre of buoyancy. Chapman, the famous Swedish naval architect, laid down the rule that the distance between these two centres should be between one-fiftieth and one-hundredth of the length; but considerable departures were made from this rule in practice. Cases occurred where the distance was as great as one-thirtieth of the length.

A similar practice still prevails in the designing of merchant sailing ships; and even greater variations occur in the relative positions of the two centres. Cases have occurred where the centre of effort has been as much as one-twentieth of the length before the centre of buoyancy; and others where it has been one-fiftieth of the length abaft. Such variations clearly indicate an absence of conformity to any fixed rules, other considerations—such as convenience of stowage or accommodation—largely influencing the longitudinal distribution of the sail.

Having decided upon the proper distance between the centre of effort and centre of lateral resistance for a new design, it is next necessary to station the masts and distribute the sail in such a manner that the required position of the centre of effort may be secured, in association with sufficient manœuvring power and a proper balance of sail. In the following table the results of experience with various classes of ships are summarised, all the vessels being supposed capable of proceeding under sail alone.

The length of a ship at the load-line, from the front of the

stem to the back of the sternpost, being called 100, the other lengths and distances named will be represented by the following numbers:—

Rig and Class of Vessel.	Distance from Front of Stem.			Base of Sail.
	Foremast.	Mainmast.	Mizenmast.	
Ship or Barque Rig:—	125 to 160
Obsolete classes of sailing-ships of war	12 to 15	55 to 58	80 to 90	..
Unarmoured war-ships, steam and sail	13 to 18	56 to 59	84 to 86	..
Sailing merchantmen	20 to 22	53 to 55	80 to 88	..
Ditto (four masts)	14	38 to 40	{ 64 to 66 } Jiggermast. { 86 to 87 }	..
Brig	17 to 19	64 to 65	..	160 to 165
Schooner*	16 to 22	55 to 61	..	160 to 170
Cutter	36 to 42	170 to 190
Yawl	38	..	{ variable } abaft { sternpost }	..
Ketch	39	..	90	..

This table requires only a few words of explanation. The four-masted merchantmen named therein are vessels of large size (260 to 280 feet in length, and 3500 to 4500 tons load displacement); they require very large spreads of canvas, and the employment of the fourth or “jigger” mast enables the designer to keep the centre of effort lower than it could be kept, with an equal sail-spread, on three masts. Four masts were originally fitted in the ironclad *Achilles*, but the rig did not prove successful. Similar remarks apply to the five-masted rig of the *Minotaur* class. In the merchant steamships, 400 to 550 feet long, four or five masts are sometimes employed; but in them efficient performance under sail is not looked for. This is also true of the *Great Eastern* which, with her six masts, carries a sail-spread altogether disproportionate to her size.

The “rake” given to the masts in different classes of ships requires a few words of explanation. In nearly all cases it is an inclination *aft* from the vertical line drawn through the heel of the mast; but in vessels with “lateen” rig the foremast commonly rakes forward considerably. The following are com-

* These are Fincham’s rules: in modern schooner-yachts no fixed rule appears to be followed, the masts being placed much closer together, in order to increase the size of mainsail.

mon values for the rake aft. In cutters, from $\frac{1}{12}$ to $\frac{1}{9}$ of the length; in schooners, for foremast, from $\frac{1}{10}$ to $\frac{1}{4}$, and for mainmast, from $\frac{1}{6}$ to $\frac{1}{4}$; in brigs, for foremast, from 0 to $\frac{1}{50}$, for mainmast, from $\frac{1}{16}$ to $\frac{1}{3}$; in ships, for foremast, from 0 to $\frac{1}{36}$, for main and mizen masts, from 0 to $\frac{1}{2}$. It is customary to have the greatest rake in the aftermost mast, and the least in the foremast. Graceful appearance, greater ease and efficiency in supporting the masts by shrouds and rigging, and the possibility of bracing the yards sharper when the masts are raked aft and the rigging led in the usual way, are probably the chief reasons for the common practice. The "steeve" given to the bowsprit is also in great measure a matter of appearance; but it is useful, especially in small vessels, in giving a greater height above water for working the head-sails in a sea-way. In some large war-ships intended to act as rams, the bowsprits are fitted to run-in when required, and the steeve is very small; but the height above water is considerable.

It will be observed that the table also gives a length for the "base of sail," in terms of the length of the ship, and this exercises an important influence on the manœuvring power of a vessel. In Fig. 126 it would be measured from the foremost corner (or "tack") of the jib to the aftermost corner (or "clew") of the driver; in other classes it would be measured between extreme points corresponding to those named. The base of sail was usually proportionally greater in vessels wholly dependent on sail-power than it is in vessels with steam- and sail-power, the foremast being placed further forward and the mizenmast further aft than is now common. Special circumstances may, however, limit the length of the base of sail; and one of the most notable cases in point is to be found in her Majesty's ship *Temeraire*, a *brig-rigged* vessel of over 8400 tons displacement, where the departure from ship rig has been made in order to facilitate the arrangements for the heavy chase guns at the bow and stern.

Experience has also led to the formation of certain rules for determining the proportionate areas of the sails carried by the different masts, with various styles of rig. According to Mr. Fincham and other authorities, in ship-rigged sailing vessels of the earlier classes, if the area of the plain sail on the mainmast was called 100, that on the foremast varied from 70 to 77, and on the mizenmast from 46 to 54. It is now usual in the ships of the Royal Navy to make the corresponding sails on the fore and main masts alike, except the courses; and calling the sail-area

on the mainmast 100, that on the foremast would commonly be from 90 to 95, that on the mizen 45 to 55, and the jib from 15 to 20, the latter agreeing fairly with the practice in sailing vessels. In barque-rigged vessels the sail-area on the mizen is often about one-third only of that on the main; the sail-area on the foremast having about the same proportion as in ships. In brigs the sail on the foremast varies from 70 to 90 per cent. of that on the main; in schooners it is often about 95 per cent.

In sailing merchantmen the distribution of sail varies considerably. The following appear to be good average values. Calling the sail-area on the mainmast 100 in ship-rigged vessels, that on the foremast varies from 90 to 95, and on the mizen from 55 to 60; the jib varies from 10 to 12. In barque-rigged vessels the corresponding numbers are: mainmast 100, foremast 90 to 95, mizen 25 to 30, jib 10 to 15. In four-masted ships the main and mizen carry about equal sail-areas; calling this 100, the jib is about 8 to 10, the foremast 85 to 95, and the jigger 55 to 60 in some good examples; in a four-masted barque the jigger has been found as little as 20 to 25.

Another feature somewhat affecting the handiness of a ship under sail, particularly in the earlier movements of any manœuvre, is the distance of the centre of gravity of the ship from the centre of effort. This consideration was formerly treated as of great importance, but it now has little influence in the actual arrangement of sail plans. The longitudinal position of the centre of gravity for the load-draught is usually fixed by other and more important conditions; and its position changes considerably as the amount and stowage of weights on board are varied. It will suffice to say, therefore, that, when the ship is turning, her motion of *rotation* may be regarded as taking place about a vertical axis passing through the centre of gravity; which point simultaneously undergoes a motion of *translation*. Hence it follows that the turning effect of any forces will vary with the distance from the centre of gravity of their line of action.* Suppose a ship to have all plain sail set, and balanced so that her course can be kept without using the rudder, the line of action of the resistance will then lie in the same vertical plane with the resultant wind pressure, which may be supposed to pass through the centre of effort. Then, in tacking, the resist-

* See further, Chapter XIV.

ance tends to throw the head of the ship up into the wind and to assist the helm, but it tends to resist the helm in wearing. The further forward of the centre of gravity the centre of effort is placed, the greater will be the *initial* turning effect of the resistance when a manœuvre begins. But as soon as changes are made in the sails which “draw” in order to assist the manœuvre, and as soon as the action of the rudder is felt, the speed and course of the ship alter, and the initial conditions no longer hold, the line of action of the resistance changing its position from instant to instant.

Lastly: in arranging the sails of a ship, it is necessary to consider their *vertical* distribution, which governs the height of the centre of effort, and the “moment of sail” tending to produce transverse inclination.

The specimen calculation on page 502 shows the ordinary method of estimating the vertical position of the centre of effort when the plain sail is braced fore-and-aft; and no explanation will be needed of this simple calculation. In previous chapters, explanations have been given of the action of the wind on the sails, and of the resulting strains on the rigging and topsides.* It will suffice, therefore, to state that, if the line of action of the wind is assumed to be horizontal, the steady speed of drift to leeward will supply a resistance equal and opposite to the wind pressure, and having a line of action approximately at mid-draught. This couple will incline the ship transversely until an angle of heel is reached for which the moment of stability equals the moment of the inclining couple. Let A = area of plain sail, in square feet; h = the height (in feet) of the centre of effort above the mid-draught, when the ship is upright; m = the metacentric height (GM) in feet of the ship; D = the displacement (in pounds); p = the pressure, in pounds per square foot, which the assigned velocity of the wind would produce upon a plane placed at right angles to it; and a = the angle of steady heel. Then, within the limits of the angles of steady heel reached in practice, the following equations may be considered to hold:—

$$\text{Moment of sail, to heel ship} = A \times h \times p \cos^2 a;$$

$$\text{Moment of statical stability} = D \times m \times \sin a;$$

* See pages 310, 323.

whence is obtained the following equation for the angle a ,

$$\sin^2 a + \frac{D \cdot m}{A \cdot p \cdot h} \sin a - 1 = 0.$$

Since a is usually an angle of less than 6 or 8 degrees, this equation may, without any serious error, be written,

$$\frac{D \cdot m}{A \cdot p \cdot h} \sin a = 1; \text{ or } \sin a = \frac{A \cdot p \cdot h}{D \cdot m}.$$

Suppose, for example, that $p = 1$, and that, in the case of Fig. 126, $D = 6,800,000$; $m = 3$ feet; $A = 15,600$; and the mean draught 20 feet. Then $h = 62 + 10 = 72$ feet;

$$\sin a = \frac{15,600 \times 72}{6,800,000 \times 3} = \frac{468}{8500} = \frac{1}{18} \text{ (nearly),}$$

$$a = 3\frac{1}{4} \text{ degrees (nearly).}$$

It has already been remarked that, for the force of wind when all plain sail would be set, the normal pressure per square foot is usually assumed to be about 1 lb.; and it is very common, in comparing the stiffness of ships, to assume that the pressure p has the value unity.

Looking back to the formula for the angle of steady heel, it will be seen that, if the ratio of $D \cdot m$ to $A \cdot h$ be the same for any two vessels, an equal force of wind p per square foot of area of sail will produce equal angles of heel in both ships. Hence it has become the practice in the Royal Navy to use this ratio as a measure of the "power of a ship to carry sail." The smaller the ratio, the less is the stiffness of the ship under canvas; the greater the ratio, the stiffer is the ship. Very considerable variations occur in this ratio in different classes. In the *Inconstant*, a vessel designed for high speed under steam as well as for sailing, the number expressing the power to carry sail is as low as 15; in the converted ironclads of the *Prince Consort* class, with metacentric heights twice as great as that of the *Inconstant*, and with a much smaller proportionate spread of canvas, the corresponding number is 51. In some of the earlier ironclads, such as the *Warrior* and *Minotaur* classes, the sail-carrying power is represented by 30 to 35; in the recent ironclads it has been represented by 17 to 25. In the various classes of unarmoured ships very different values occur: from 20 to 25 probably represents the sail-carrying power of the screw frigates of the older type, from 15 to 20 that of the corvettes, and from 10 to 15 that of the smaller classes. Exact information is wanting as to the meta-

centric heights of the older classes of sailing ships of the Royal Navy, so that no exact estimates can be made of their sail-carrying powers. It appears probable that in the smaller classes the numbers varied between 10 and 15; for the frigates, from 15 to 20; for the line-of-battle ships, from 20 to 30.

The diminution of the metacentric heights in some recent types, in order to secure longer periods of oscillation, which favour greater steadiness, has led to a decreased stiffness as compared with preceding types; this latter feature being indicated by the smaller numbers of the sail-carrying power. In other words, greater angles of steady heel under canvas are now common than were formerly customary. It was important when ships had to fight under sail that the angle of heel should not be excessive, and 5 or 6 degrees was the limit named by writers on the subject; in steamships there is no equally powerful reason for securing equal stiffness, steadiness being the chief desideratum, and angles of heel under plain sail of 8 or 10 degrees sometimes occur.

Respecting the actual sail-carrying powers of merchant ships, there is no recorded information, and (from the remarks on page 85) it will be obvious that on different voyages, with varying character and stowage of cargoes, there must be great variations in the metacentric height, carrying with them considerable changes in the sail-carrying power. Assuming that the ships are so stowed that they have metacentric heights of 3 to $3\frac{1}{2}$ feet, the sail-carrying powers in a great number of cases we have investigated lie between 14 and 18. Mr. W. John gives 12 to 20 as corresponding values with $3\frac{1}{2}$ feet metacentric height. It may be desirable again to state that sailing merchantmen have forms and proportions such that, if they are stowed so as to secure the amount of stiffness assumed, they must have a large range of stability. But they are liable to be much less favourably situated, both as regards stiffness and stability, if improperly stowed.

The spread of sail carried by yachts has been shown to be enormous in proportion to their displacement, and their metacentric heights being moderate, their sail-carrying powers are small. In some very successful English yachts the sail-carrying power lies between 4 and 8. For cruising vessels it has been found to lie between 6 and 8. In the *Sunbeam*, with auxiliary steam-power, it is 8.4. In match sailing, steady angles of heel of 20 to 30 degrees are said to be not uncommon; but there is little risk of such vessels being capsized, as the ballast brings the centre of gravity very low, and they have extremely great range of stability (see curves on Fig. 47*e*, page 128).

Useful as the formula on page 509 is for purposes of comparison, it does not enable one to estimate, with certainty, the actual angle of steady heel corresponding to a certain velocity and direction of the wind, as well as a given sail-spread and bracing of the yards. The reason is twofold. First: there are the difficulties arising from our comparative ignorance of the laws governing the pressure of wind on sails (see page 484); second, there is the uncertainty as to the distribution of the wind pressure over the large aggregate area of the sails, extending as that area does to a very considerable height. It is quite conceivable that sensible differences in the velocity of the wind may occur within the limits of height included in the sail-spread; and, if so, the moment of the wind pressure on the sails will be affected thereby. Further, it is probable that, with a given velocity of wind, the average pressure per unit of area on a sail is influenced by the size and form of the sail. And finally it is not possible to say how adjacent sails affect one another, nor how the wind pressure is influenced by obliquity of impact.

From a careful comparison of a large number of recorded angles of steady heel "under all plain sail," it appears that those angles considerably exceed the values which would be given by calculations based on the ordinary hypothesis that "plain sail" corresponds to an average wind pressure of 1 lb. per square foot of canvas. The grounds for this assumption do not appear to have been thoroughly investigated hitherto, although from the time of Chapman onwards the opinion has been generally entertained by seamen. And further investigations, with anemometric apparatus, are much required. In fact, the common system of estimating the "force of wind" by personal judgment appears to be open to serious question; and it is to be hoped that anemometers may be more generally used on board ship than they have been hitherto for the purpose of measuring both the velocity and the pressure of the winds which produce certain observed inclinations. When such exact data are available, trustworthy estimates may become possibilities; at present they are not so.

The heights of the masts and the depths of the sails were formerly proportioned to the extreme breadths of ships. Hence it became the practice to express the height of the centre of effort above the load-line in terms of the breadth. For ship-rigged vessels and barques the ratio of this height to the breadth usually lies between $1\frac{1}{2}$ and 2; for brigs and schooners between $1\frac{1}{2}$ and $1\frac{3}{4}$; and for the other rigs mentioned in the table on

page 505 it has nearly the same value. These approximate estimates are not to be put in place of exact calculations for the position of the centre of effort, but they are useful nevertheless. In order that the moment of sail may be estimated, the half-draught must be added to the height of the centre of effort above the load-line.

Generally, if there be no similar vessels to compare with a new design, the problem of the vertical distribution of the sail takes the form of a determination of the height h of the centre of effort above the centre of lateral resistance. In that case the whole of the quantities in the formula given above, except the height h , may be supposed known, the maximum angle of steady heel a being assigned for a pressure of 1 lb. per square foot of canvas. Hence

$$h = \frac{D \cdot m}{A} \cdot \sin a,$$

very nearly, when a does not exceed the usual limits.

There are also practical rules by which the ratios of the areas of the different sails, the lengths of the masts and yards, and other features of a plan of sails are governed; but for these we are unable to find space, and they can be consulted by those readers desiring information, in the standard works mentioned above.

In conclusion, brief reference must be made to the changes introduced of late years into the proportions of length to breadth in sailing ships. It was formerly assumed that the length of a successful sailing ship should not exceed four times the beam; in many vessels having a high reputation for performance and speed, the length was not much more than three times the beam. The great increase in the proportionate lengths of steamships and the consequent improvement in their performance appears to have affected the construction of sailing ships; the clippers of the mercantile marine frequently have lengths from five to six times the beam. There can, of course, now be no question as to the diminution of the resistance by the increase in the length, and greater fineness of form. In these clippers the requisite stiffness appears to have been secured with the use of very little ballast, by associating appropriate fineness of the under-water form with the greater length.

The passages made by some of these clipper ships are notable even in the days when steam navigation is being successfully

introduced for the longest voyages.* On the China trade, until the Suez Canal was opened, the clippers competed successfully with steamers, occupying from 90 to 100 days as against 75 to 80 days for the steamers. On the Australian service also the clippers have done equally well. The *Thermopylæ*, for example, made the passage from London to Melbourne in 60 days, a time only one-half longer than that taken by some of the best steamers now employed on that service.

We have been favoured by the designer of this remarkably successful vessel, Mr. Waymouth, Secretary to Lloyd's Register, with the following particulars of her design; which will enable a comparison to be made between the modern sailing ship and one of the most successful sailing frigates of the Royal Navy, her Majesty's ship *Pique*.

Particulars.	<i>Thermopylæ.</i>	<i>Pique.</i>
Length	210 feet	162 feet
Breadth	36 „	48½ „
Displacement	1,970 tons	1,912 tons
Area of plain sail	17,520 sq. ft.	19,086 sq. ft.
Area of plain sail ÷ (displacement) ² / ₃	110	124

The sail-spread of the *Thermopylæ* is, therefore, less proportionally than that of the *Pique*; but her greater length and fineness of form probably cause a considerable diminution in resistance, and give to the *Thermopylæ* greater speed in making passages than the sailing frigate possessed.

Another clipper, also designed by Mr. Waymouth, has made no less remarkable passages, viz. the *Melbourne*, owned by Messrs. Green, and employed on the Australian service. In 1876 this vessel made the passage from England to Melbourne in 74 days; experiencing far from favourable conditions during part of the voyage. From the Cape, however, fine fair winds were obtained, and for seventeen consecutive days 300 miles a day were averaged. The three longest runs in this time were 374, 365, and 352 miles per day. This vessel is about 3500 tons displacement, and her area of plain sail is rather less than 21,000 square feet; the ratio of sail-spread to the two-thirds power of the

* For a mass of interesting information on the subject, see the article on "Clipper Ships" in *Naval Science* for 1873.

displacement being about 90 to 1, or about the same as in the wooden screw frigates of the Royal Navy.

Another example of high speed under sail being obtained in vessels which have good proportions of length to beam and fine form is found in the *Inconstant*, of the Royal Navy, which has made runs at speeds of from $13\frac{1}{2}$ to $14\frac{1}{2}$ knots per hour under sail alone.

The smaller proportions of length to breadth adopted in the old sailing ships of war were probably chosen because these vessels were required to be pre-eminently handy under sail, in order to be efficient in action. In this respect the modern merchantman could scarcely compare with the earlier class; the performance of their voyages does not necessitate the possession of similar quickness in manœuvring. Moreover, the sailing ships of war had to be loftier than the merchantman, to carry considerable weights of armament, &c., on the decks, instead of cargo in the hold, and yet to be stiff under canvas, so that no great heel should be produced when going into action. In short, as with steamships of the present day, so with the sailing ships of the past: vessels of war had to be designed to fulfil conditions which permitted far less latitude in the choice of forms and proportions than is possible in the designs of merchant ships. The large number of sailing ships still employed in the mercantile marine of this and other countries makes it desirable, however, to notice any change which promotes their efficiency; and undoubtedly one such change is to be found in the increased lengths and fineness of form adopted in recent ships.

It is interesting to note that, in yachts designed for racing, the proportions of length to beam are commonly between 4 to 1 and 6 to 1, the upper limit being reached in comparatively few cases. The general selection of these proportions is good evidence that they are well adapted for the class; in which handiness and weatherliness are no less important than speed with the wind abaft the beam. There are, however, several cases on record in which these vessels have attained speeds of 13 or 14 knots per hour; and the American yacht *Sappho* is said to have made 16 knots per hour, for several consecutive hours, during her passage across the Atlantic.

CHAPTER XIII.

STEAM PROPULSION.

FORTY-FIVE years ago the employment of steamships in ocean navigation was a matter of warm debate. Steamers had been successfully employed on rivers, lakes, and inland waters, as well as on coastwise services and short sea passages. But it was urged that long voyages must still be performed by sailing ships, either because steamers could not carry coal sufficient to propel themselves over long distances or because the expenditure on the propelling power would be so great as to render remunerative service impossible. The Transatlantic service, with its voyage of 3000 miles, was more especially kept in view in these discussions; and when the *Great Western* and *Sirius* made successful passages from England to New York in 1838, the arguments against the capabilities of steamships for sea-going services, in competition with sailing ships, were practically destroyed. From that time onwards steam navigation has been continuously and rapidly developed. The sizes and speeds of individual ships have been gradually increased, and their capacities for performing long voyages made greater. For many years sailing ships remained in sole possession of the China and Australian trade; but the opening of the Suez Canal, and the consequent saving on the length of voyage from England to China, have led to the extensive use of steamers on that route; while the progress made in steamship construction has enabled the longest ocean voyage that requires to be performed, from England to Australia, to be successfully accomplished by steamers.

In the construction of steamships of war, similar progress has been made; but the period over which it has extended is less by ten or twelve years than the corresponding period in the mercantile marine. So late as 1846 experimental squadrons of sailing ships belonging to the Royal Navy were attracting

the greatest attention of all persons interested in naval affairs; and the steam reconstruction of the Navy was not fairly begun until several years after. Into the causes of this delay it is now unnecessary to enter; but it is important to note the great advances which have been made during the last twenty years. The earliest screw line-of-battle ships had speeds of about 9 or 10 knots; the latest and fastest vessels of that class did not exceed 13 knots. The armoured battle-ships now afloat have speeds of 14 or 15 knots, and are twice or thrice as heavy as their predecessors. The earlier types of unarmoured frigates and corvettes attained speeds of 10 to 13 knots; existing types of frigates and corvettes have speeds ranging from 13 to 18 knots. Hereafter it will be shown how great is the proportionate expenditure of power required to attain these higher speeds, but the mere statement of the facts will suffice to illustrate the contrast between the steaming capabilities of war-ships of the present day and those of twenty years ago.

It would be beside our present purpose to attempt even a sketch of the history of steam navigation, either for the mercantile marine or the Royal Navy; although the interest and importance of the subject cannot well be exaggerated. In this chapter we propose simply to treat of steam propulsion as it affects the work of the naval architect; and although references will necessarily be made to the work of the marine engineer, no descriptions will be given of the various types of engines and boilers in common use, nor of the many ingenious devices by which it is sought to obtain increased power and efficiency with a certain weight of propelling apparatus. Even when thus restricted, the field of inquiry that remains open is very large, and deserving of the most careful study. It includes a consideration of all the circumstances which the designer of a steamer has to take into account when determining the form, dimensions, and engine-power required to attain a certain assigned speed. An exhaustive discussion of these subjects is impossible without recourse to mathematical investigations such as cannot be introduced into this work; but it will be possible to indicate in general terms the principal deductions from such investigations, and to illustrate the principles by which the development of steam propulsion has been guided.

The problem of steamship design is not one admitting of any general solution; because the conditions to be fulfilled, in association with the attainment of certain speeds, vary greatly in different classes of ships. These conditions commonly include a

certain minimum carrying power; limitations in the draught of water, dependent upon the service in which the vessel is to be employed; limits of length, or in the ratio of length to breadth and depth; and the capability of steaming certain distances without requiring to take more coal on board; besides others that need not be mentioned. In order to fulfil all these requirements and to secure the assigned speed, joint action is necessary on the part of the naval architect and marine engineer. Upon the latter devolve the actual design and construction of the propelling apparatus; and his skill is displayed in providing machinery which shall be compact, durable, strong, as light as possible in proportion to the power developed, and economical in the consumption of fuel. The requirements of the engineer also exercise considerable influence upon the internal arrangements, particularly in the appropriation of the spaces for the machinery, the efficient ventilation of those spaces, and the structural arrangements necessary to resist the local strains incidental to propulsion. Furnished with the opinion of the engineer on all these matters, and with data as to the ratio which the weight of the machinery will bear to its power, the naval architect proceeds to approximate to the form and dimensions most suitable for the new ship.

This approximation is necessarily made tentatively. In the earlier stages, the engine-power must be expressed in terms of the assigned speed, and of a displacement which is itself unknown. Upon the power of the engines must depend their weight, and the weight of coal to be carried for a voyage of given length. And, further, the weight of hull, as well as the weights of certain parts of the equipment, must vary with the total weight of the ship, her extreme dimensions, type and structural arrangements. Apart from experience, a problem involving so many unknown quantities could scarcely be solved; but, guided by the results obtained in actual ships, the designer can proceed with a considerable degree of confidence. For example, he may express the weight of hull, &c., as a fraction of the displacement; and if the new ship is not very dissimilar from existing types, of which the performances under steam have been recorded, it is also possible to determine, in terms of the displacement, the power and weight of the machinery, as well as the appropriate coal supply. The remaining part of the displacement will consist of the weights to be carried; these are given quantities, and hence an equation may be formed from which the displacement may be estimated with a close approach to accuracy.

The case is more difficult when the new design is to be of novel form or unprecedented speed; and apart from model experiments such as were described in Chapter XI., page 471, considerable doubt may surround the approximation to the dimensions and displacement. With such experiments, however, it is possible to compare the resistances of alternative forms; to select that which best fulfils the essential conditions, in association with the least proportionate resistance; and afterwards to express with a fair approach to accuracy the engine-power required to propel the ship at the desired speed, in terms of the product of that speed into the corresponding resistance.

Measures of Horse-Power: Effective, Nominal and Indicated.

The "useful work" performed by the engines of a steamer moving at a certain speed, is measured by the product of the resistance corresponding to that speed into the distance through which that resistance is overcome in a unit of time.* It will be remembered that the term *resistance* has been applied to the strain which would be brought upon a tow-rope if the ship were drawn along by some external force which did not interfere with the free flow of water past her hull. Suppose the resistance (R) to be expressed in pounds, and the speed (S) in feet per second; then the

$$\text{Useful work (per second)} = R \cdot S \text{ (units of work).}$$

One "horse-power" represents 33,000 units of work per minute, or 550 units per second; hence for the horse-power corresponding to the useful work, or "effective horse-power," as it is termed, we have

$$\text{Effective horse-power (E.H.P.)} = \frac{R \cdot S}{550}$$

For example, in the *Greyhound* experiments it was found that the resistance at a speed of 16.95 feet per second, equalled 10,770 lbs.

$$\text{Effective horse-power} = \frac{10,770 \times 16.95}{550} = 332.$$

This effective horse-power differs considerably from the actual

* See the remarks on "Work" at page 144.

horse-power developed by the engines; but before endeavouring to explain the causes which influence the ratio which the useful work bears to the total work of the engines, it may be well to describe how the latter is usually expressed, in order to assist readers unfamiliar with the subject.

The power of marine engines is expressed either in "nominal" or "indicated" horse-power. Indicated horse-power measures the work done by the steam in the cylinders during a unit of time. If the effective mean pressure of the steam upon the pistons is p lbs. per square inch of the total piston area (A square inches); if l be the length of the "stroke" of the pistons (in feet), and n the number of strokes made per minute: then the total mean pressure on the pistons will be pA lbs., and the distance through which it acts (or speed of piston) will be nl feet per minute. The work performed per minute is therefore given by the expression—

$$\text{Work} = p \cdot A \times n l \text{ (units),}$$

and this is equivalent to

$$\text{Indicated horse-power (I.H.P.)} = \frac{p \cdot A \times n l}{33,000}.$$

The effective mean pressure of the steam is ascertained from diagrams, drawn by means of the useful little instrument known as the "indicator;" and hence the term "indicated horse-power" is derived.* It will thus be seen to have a definite meaning, although it is by no means a complete representation of the efficiency of the propelling apparatus. It takes no account of the efficiency of the boilers as steam generators, or of the rate of coal consumption, or of other important matters; but notwithstanding these omissions, the naval architect most fairly expresses the power required to drive a ship by the indicated power of her engines. The same measure will be employed in the estimates which appear in the subsequent parts of this chapter, except where the contrary is expressly stated.

"Nominal" horse-power was formerly the sole measure which appeared in the Navy List for her Majesty's ships; it is still the only measure appearing in the Mercantile Navy List, and is still

* For details of this instrument and its mode of application, the reader must refer to works on the steam-engine, wherein will also be found

information respecting the very various pressures of steam, and speeds of piston, used in different types of engines.

used in the French and American navies. Simultaneously with the introduction of displacement tonnage, instead of the B.O.M. for the ships of the Royal Navy, indicated horse-power was introduced into the Navy List; it alone appears for ships of recent design, but for vessels of earlier date both the nominal and indicated powers appear. The following examples will show how greatly different in different ships might be the ratio of the nominal power to the actual or indicated power of the engines.

Ships.	Horse-power.		Ratio of I.H.P. to N.H.P.
	Indicated.	Nominal.	
<i>Albacore</i> . . .	109	60	1·82
<i>Spiteful</i> . . .	796	280	2·85
<i>Supply</i> . . .	265	80	3·31
<i>Simoom</i> . . .	1576	400	3·94
<i>Hector</i> . . .	3256	800	4·07
<i>Agincourt</i> . . .	6867	1350	5·03
<i>Bellerophon</i> . .	6521	1000	6·52
<i>Monarch</i> . . .	7812	1100	7·13
<i>Penelope</i> . . .	4703	600	7·84

The cause of these differences is to be found in the rules by which the nominal horse-power was calculated. For all ships, instead of the true mean pressure of the steam on the pistons, a fictitious pressure of 7 lbs. per square inch was assumed. In screw steamers, the *intended* piston speed (say in feet per minute) was taken as the true speed, and

$$\left. \begin{array}{l} \text{Nominal} \\ \text{horse-power} \end{array} \right\} = \frac{7 \times \text{area of pistons} \times \text{intended speed of piston}}{33,000}$$

In paddle steamers not even the intended piston speed was regarded, but a fictitious speed was assumed, according to a law which has been thus stated—

$$\left. \begin{array}{l} \text{Assumed speed of piston (feet)} \\ \text{per minute)} \end{array} \right\} = 129\cdot7 (\text{length of stroke})^{\frac{1}{3\cdot28}}$$

and for these vessels

$$\text{Nominal horse-power} = \frac{7 \times \text{area of pistons} \times \text{assumed speed}}{33,000}$$

The manufacturer of the engines was usually under no obligation

to conform to the assumed speeds of piston, and often exceeded them; while the assumed mean pressure was much below the effective mean pressure; two facts which explain the very different ratios of nominal to indicated horse-power which existed in different vessels. The change from nominal to indicated horse-power for the ships of the Royal Navy has so generally commended itself that further remarks are needless.

In the French navy the nominal horse-power is *one-fourth* of the power which it is expected the engines will develop; and in a large number of cases the actual indicated power is found to lie between 4 and $4\frac{1}{2}$ times the nominal power. A French "horse-power" (*cheval vapeur*) is rather less than the English, being 32,549 foot-pounds per minute, instead of 33,000. To convert French into English measures, the former must be multiplied by 0.9863.

Nominal horse-power for the British mercantile marine is not defined by law. Formerly the rule established by the practice of Messrs. Boulton and Watt was generally employed; it was very similar to the old Admiralty Rule for paddle steamers, the same effective pressure of 7 lbs. per square inch of piston area being assumed; but the

$$\text{Assumed speed of piston} = 128 \sqrt[3]{\text{Length of stroke.}}$$

This rule has not fallen into disuse, but is sometimes stated as follows:—Let D^2 = sum of squares of diameters of cylinders (in inches); then—

$$\left. \begin{array}{l} \text{Nominal} \\ \text{horse-power} \end{array} \right\} = \frac{1}{47} \times D^2 \times \sqrt[3]{\text{length of stroke.}}$$

The commercial nominal horse-power is, however, very frequently represented by the following expression:—

$$1 \text{ nominal horse-power} = 30 \text{ circular inches of piston area.}$$

A "circular inch" being a circle of 1 inch diameter, the total nominal horse-power of a set of engines would be obtained by finding the number of circular inches in all the piston areas, and dividing by 30. This rule corresponds with that of Messrs. Boulton and Watt, when the piston speed is assumed to be 200 feet per minute.

Various proposals have been made with a view to improving the commercial method of measuring horse-power, but none of them

has found general favour. In 1872, the council of the Institution of Naval Architects, having been consulted on the subject by the Board of Trade, replied as follows:—"The term nominal "horse-power, as at present ordinarily used for commercial "purposes, conveys no definite meaning." . . . "The majority "of the committee were of opinion that no formula depending "upon the dimensions of any parts of the engines, boilers, or "furnaces could be relied upon as giving a satisfactory measure "of the power of an engine; and that even if the varieties of "engines and boilers now in use could be comprised under one "general expression for the power, the progress of invention "would soon vitiate any such expression or formula." The committee could not agree to any alternative mode of measuring engine-power, but the plan which met with least objection was to take either the indicated power on a trial trip as the nominal power, or some submultiple, such as *one-fourth* of the indicated power; the latter would be very nearly the same as the French rule. So far as we are informed, no action has yet been taken to give effect to the recommendations, and to assign a uniform or definite meaning to a nominal horse-power in the mercantile marine.

Principal Types of Marine Engines: Relative Weights and Rates of Coal Consumption.

In selecting the type of engine to be employed in a new ship in consultation with the marine engineer, the designer has to consider the ratio of the weight of the various types to their indicated horse-power, and their relative coal consumption. It is usual to express the weight of machinery in "hundredweights per indicated horse-power" and the coal consumed in "pounds per indicated horse-power per hour." Both these quantities may be affected by the special conditions to be fulfilled in various ships, especially in war-ships, even for any single type of engine; but the following brief statement may be of service, representing, as it does, the average results of good practice. Four types of machinery—including in that term both engines and boilers—are now extensively used in the Royal Navy and the mercantile marine. First, the earlier type with low-pressure steam (25 to 30 lbs.), simple-expansion and jet condensers, such as is fitted in the *Warrior* and other earlier ironclads. Second, the type largely used in the Royal Navy in vessels built in 1863-71, with low-pressure steam (30 lbs.), simple-expansion and surface con-

densers. Third, the compound type, with high-pressure steam (60 to 120 lbs.), that has been almost universally adopted in the mercantile marine, and largely used in ships of the Royal Navy during the last ten years. Fourth, what may be termed the "torpedo-boat" type, with locomotive boilers worked at 110 to 140 lbs. pressure, under forced draught, and with lightly-constructed but beautifully-finished compound engines. Besides these types there are others in use, but nothing need be said respecting them here.*

For the four selected types the average weights and rates of coal consumption at full speed are approximately as follows:—

Type of Machinery.	Weight per indicated Horse Power.	Rate of Coal Consumption per indicated Horse Power per hour.
	cwts.	lbs.
1. Simple expansion : jet condenser	$3\frac{1}{2}$	4 to 6
2. do. do. surface condenser	3	3 to 4
3. Compound : Royal Navy	3 to $3\frac{1}{2}$	2 to $2\frac{3}{4}$
" mercantile	$3\frac{1}{2}$ to 5	$1\frac{3}{4}$ to $2\frac{1}{2}$
4. Torpedo-boat : small scale	$\frac{1}{2}$ to $\frac{3}{4}$	$3\frac{1}{2}$ to 4
Torpedo-ships : large scale	$1\frac{1}{2}$ to $1\frac{3}{4}$	$3\frac{1}{2}$ to 4

It may be proper to explain further that the weights and coal consumptions for the first three types correspond to the trials made with natural draught; whereas in the fourth group the stokeholds are closed, and air is forced into them under pressure by the action of powerful fans. The large consumption of fuel is due, therefore, to the action of the forced draught, the boilers being relatively overworked; and it has yet to be discovered by experience how long a vessel fitted with such boilers could continue to run at full speed. Hitherto this type of machinery has been used only in vessels where the maintenance of high

* While these sheets were passing through the press, the Author was furnished by Mr. Kirk (of Messrs. Napier & Sons) with the results of the earliest trials made with the triple expansion (three cylinder) engines, designed by Mr. Kirk for the s.s. *Aberdeen*. These results appear to promise a very notable advance in economy of coal-consumption—amount-

ing to 20 to 25 per cent. as compared with good compound engines, on an ocean voyage. Further experience with the new type will determine its relative value more precisely; but if the promise of the first trials is fulfilled the system must have a remarkable influence on the economical performance of long voyages.

speeds for comparatively short times meets the conditions of service; and fresh water has been used in the boilers.

Other types of high-pressure boilers have been tried on a small scale, and some of these are said to combine lightness equal to that of the locomotive boiler (water included), with greater economy in coal consumption. Of these special "coil" boilers that devised by Messrs. Herreshoff appears to be one of the most promising. It has been fitted in a large number of launches, yachts, and torpedo-boats, a few of which have been purchased for the Royal Navy. Exhaustive trials have been made by engineer officers of the United States navy on this type of boiler, and in some of the most recent trials it has been stated that the expenditure of anthracite coal was only $2\frac{1}{4}$ lbs. per indicated horse-power per hour when steaming full speed. This boiler requires fresh water for its most efficient action; and when this condition is fulfilled it appears to be capable of being steamed continuously over long periods. It has the further advantages of enabling steam to be raised quickly, and of practically removing risk of serious damage by explosion. On the other hand, it has some disadvantages, requiring very careful treatment to keep steam; but intelligent management and special training are also needed with the locomotive type of boiler. So far as we are informed, experience with the Herreshoff boiler has been limited, up to the present time (1881), to small vessels having only one boiler. The difficulties of successfully working a group of such boilers may be greater than those incidental to dealing with a single boiler; but they will probably be overcome. There are other forms of coil boilers in use, some of which have given satisfactory results, and in this direction further progress may be expected. If this expectation is realised, and economical rates of coal consumption can be associated with extreme lightness in the boilers, the effect upon steamship construction will be marked.

Another means of economising the weight of machinery required for a given horse-power is found in the application of "forced draught" to ordinary high-pressure boilers. There are various methods of doing this. One of the most common hitherto has been the use of steam-jets in the funnel: this gives a greatly increased rate of combustion, but is wasteful of steam. It is stated on good authority that, whereas the rate of combustion has been increased from 40 to 50 per cent., the gain in indicated horse-power has only been 15 per cent. above that obtained with the natural draught. In other words, the rate of coal consumption per indicated horse-power per hour has been increased about

one-third by the use of the steam blast; and on this, as well as on other grounds, this form of forced draught can only be considered applicable for comparatively short periods. Another plan of forced draught consists of blowing air into the funnel, but this did not succeed in the experiments made in this country. Still, another proposed by M. Bertin, and tried in France, consists in compressing air by suitable machinery, and delivering jets into the base of the funnel;* this is said to have been successful, giving an increase of 40 per cent. on the indicated horse-power with about 20 per cent. increase on the coal burnt per indicated horse-power per hour. Still, another plan consists in blowing air into the ash-pits, but this was not found successful. General opinion now favours the method of drawing air down by fans and putting the whole stokehold under pressure. This has been done largely in recent French war-ships, and in some vessels built in this country. Further experiments are also in progress in ships of the Royal Navy. It is stated that in this manner an increase of from 30 to 50 per cent. may be obtained as compared with the indicated horse-power obtained with natural draught. This advantage of course involves less economy in coal consumption, but not so great a reduction as with the steam blast. Probably with ordinary high-pressure boilers 20 to 25 per cent. increase in the rate of coal burnt per indicated horse-power per hour would not be far from the result attained with forced draught, although we cannot give a decided statement on the point from the facts on record.

A few simple examples may be of service as illustrations of the influence which the type of machinery selected may have upon the size or the efficiency of a ship.

First, let attention be directed to the advantages which may result from the use of a type of machinery which economises fuel. Her Majesty's ship *Devastation* has engines of the low-pressure surface-condensing type, which indicated on trial more than 6600 horse-power, and drove the ship 13·8 knots per hour. These engines weigh 1000 tons, and the total coal supply carried at the normal draught is 1350 tons. The *Nelson*, an armoured ship of later date, has compound engines, which on trial developed as nearly as possible the same power, and weigh only about 30 to 40 tons more than the engines in the *Devastation*, although they

* See a *Mémoire* in the *Proceedings of La Société d'Encouragement pour l'Industrie Nationale*, 1877.

consume only *two-thirds* as much coal per hour. Hence it follows that, if the engines of the *Nelson* were fitted in the *Devastation*, 900 tons of coal would have sufficed to drive the latter ship as far as the 1350 tons she carries can drive her; so that, if the steaming distance were kept unaltered, the use of compound engines in the *Devastation* would enable no less than 400 tons to be added to the weight of armour, armament and equipment; or, if it should be preferred to increase the steaming distance, keeping the coal supply at 1300 tons, would permit the ship with compound engines to travel nearly half as far again as she can with her present machinery.

In ocean-going mercantile steamers, economy in coal consumption is no less important than in war-ships, because their commercial success depends so largely upon their power of carrying cargo. For instance, a large Transatlantic steamer with compound engines burns, say, 800 tons of coal on the voyage; if she had simple engines of the jet-condenser type she would burn 1800 to 2000 tons, and with the surface-condenser type about 1200 to 1400 tons. Hence it will be seen how considerable would be both the saving on coal and the gain in carrying-power resulting from the adoption of an economical type of machinery.

The longer the voyage and the larger the proportionate coal supply, the greater are the gains of the modern type. For example, a steamer which now has to carry a weight of coal equalling *three-tenths* of her total displacement, in order to perform the voyage to Australia, might have nearly *one-fourth* of the displacement available for cargo. But if she had engines of the early type, consuming coal twice as rapidly, she would require to carry coals amounting to *three-fifths* of her total weight, and could carry no cargo. If she had engines of the surface-condensing type, the coal supply would have to be increased to nearly *one-half* the displacement; and after allowing for the small saving on the weight of engines, as compared with the compound type, the weight of cargo that could be carried would be very small—not one-half that which the modern ship would carry. These are not mere estimates, but simple statements of fact based upon the particulars of ships now employed upon the service. And it is to the improvements in marine engines, which have brought about such great economy in consumption of fuel, that the moderate size of these successful ships is due. When the design of the *Great Eastern* was in contemplation, no such results had been attained, and it appeared necessary to build a ship of extraordinary dimensions, for a service which is now success-

fully accomplished by ships of less than one-fourth her displacement.

Next, we will illustrate the influence which the use of forced draught may have upon the maximum speed attainable with a given weight of machinery in a ship fitted with ordinary boilers. Take, for example, the despatch vessel *Iris* of the Royal Navy. At her load-draught she attained a speed of 18 knots per hour, with an indicated horse-power of about 7300; and at 16 knots she required about 5000 horse-power. Suppose a new vessel to be built of identical form, with compound engines which, with natural draught, should develop 5000 horse-power, the weight of the machinery would be, say, 800 tons, and the coal consumption about 2 lbs. per indicated horse-power per hour. Next, suppose that the forced-draught system is applied to this vessel, and that the French experience is repeated, the same machinery, with 20 or 30 tons of special appliances, will develop 6500 horse-power, and increase the speed to something like $17\frac{1}{4}$ knots. Of course this increased development of power and more rapid combustion in proportion to fire-grate area does not favour economy in coal consumption. Probably the coal burnt per hour, as compared with the natural draught and 16 knots speed, would be increased from about 5 tons to about 8 tons. This forced-draught condition is not designed, however, to be continued for long periods; and it will be observed that if the 6500 horse-power were put into the ship on the ordinary compound principle, there would be at least 200 tons greater weight of machinery than with the forced-draught arrangement, besides a considerably greater first cost. Hence, it will be seen that for war-ships, which only rarely and for comparatively short intervals need to be driven at full speed, this forced-draught system promises to be most useful. Experience in vessels now under construction will soon place the matter beyond the experimental stage. For merchant ships steaming over long distances, and mostly at speeds approaching their full speeds, the forced-draught system does not appear to be suitable; but for special vessels steaming short distances it may be worth consideration.

For short distance steaming at high speeds, the locomotive type of boiler, and engines running at high piston speeds, similar to those fitted in torpedo-boats, also deserve consideration. It is true that as yet experience on a large scale with this type of machinery is comparatively limited. Nearly all its applications have been in vessels having moderate engine-power fitted with a single boiler; but in the torpedo-ram *Polyphemus*, of the Royal

Navy, and in some foreign vessels of war, the experiment is now being tried on a larger scale. As thus applied, the extremely small ratio of weight of machinery to indicated horse-power attained in the torpedo-boats is not reached, for reasons which will be obvious. Proposals have been made, it is true, to fit very quick-running engines in order to save weight, and to "gear down" from their speed to the appropriate speed of the screws in large ships; but nothing of the kind has yet been done. But supposing that the extreme lightness of the torpedo-boat machinery could not be attained, quite an appreciable saving might be effected in special vessels, such as the Channel passenger steamers, where shallowness of draught and high speeds are of the first importance. To illustrate this, take the case of the fast steamers built by Messrs. Samuda, which required 2800 horse-power to drive them $18\frac{1}{2}$ knots on the measured mile. They have simple engines with low-pressure steam—type (1) in the table on page 523, and the total weight of the machinery is 320 tons. If it were possible to fit machinery as light in proportion to its power as that in the *Polyphemus*, then about 220 tons would suffice for the same power. The coal consumption would reach one-third more, perhaps, with the locomotive type of boiler; but on this short run this difference is unimportant. This is, of course, an incomplete comparison, because the change suggested involves the substitution of screws for paddle wheels, and might also necessitate changes in form. Enough has been said, however, to justify the statement made above, that for short distances the use of the torpedo-boat type of machinery may be worth consideration.

For ocean steaming at high speeds over long distances, the locomotive type of boiler does not appear suitable, in the form which has been used in torpedo-boats; because of its incapacity for being worked continuously for long periods at high power, its need of fresh water, and its relatively high rate of coal consumption. There is no doubt but that the first two difficulties might be overcome by special arrangements; such as the use of spare boilers which would permit individual boilers to be shut off and cleaned at frequent intervals, or the fitting of special condensing boilers to furnish fresh water to the locomotive boilers. Such arrangements would involve some additional weight and work in management, but they are practicable. A more serious matter is the high rate of coal consumption, which has not yet been reduced much below about double the rate of a good compound engine. To illustrate this statement take again the case of a first-class Transatlantic

steamer, developing about 5500 horse-power, and burning 850 tons on the voyage. Suppose her machinery in full working order to weigh 1250 tons and to be capable of developing 6500 horse-power on the measured mile; also, suppose that 1000 tons of coal are carried—the total weight of machinery and coal will be 2250 tons. Next, suppose that the torpedo-boat type of machinery is to be fitted, with spare locomotive boilers, condensing boiler, &c., and that the weight of machinery complete is 450 tons—or about 1.4 cwt. per horse-power indicated on a measured mile run—the coal consumption on the voyage, including that for condensing, may be put at something like 1800 tons: so that 2000 tons of coal would require to be carried and, with the machinery, a total weight of 2450 tons would be reached. These figures are not put forward as accurate, but simply as indicative of the condition that, under present circumstances, for long distance steaming the economy of weight in machinery possible with locomotive boilers is counterbalanced or more than counterbalanced, by increased coal consumption. For longer distances than the Transatlantic passage, the comparison would, of course, be more favourable to the compound type. At the same time it is far from improbable that improvements may be introduced into marine boilers, resembling the locomotive type, by which their rate of coal consumption may be reduced, their weights being kept below that of ordinary high-pressure boilers such as are now in general use. Or it may happen that other types of boilers suitable for raising high-pressure steam, economical in coal consumption, and light in proportion to their power will come into use. From the remarks made above as to the Herreshoff boiler, it will appear that there is already some prospect of such a change; but further experience is needed. Meanwhile in some large war-ships of great speed and power, there is being carried out a combination of the ordinary high-pressure and the locomotive boiler. About one half the maximum power is being put into the one kind of boiler, and one-half into the other. There are separate sets of engines connected with each description of boiler; and arrangements are made to throw the engines using the higher-pressure steam in or out of gear with the screw shafting. Under ordinary circumstances of cruising the economical boilers would be worked and the engines connected with them. When full speed is to be reached the whole machinery is put into operation. Besides the reduction in weight of machinery thus rendered possible there is a reduction in the waste-work of the

engines when the ships are steaming at moderate speeds (see page 564).

From this brief sketch of the present condition and probable developments of marine engines and boilers it will be seen that for every new design the selection of the most appropriate type of machinery is a matter of great importance. This selection is the joint work of the naval architect and the marine engineer, upon whose united action and cordial agreement the ultimate success of the new ship must largely depend.

General considerations relating to Propellers.

The selection of the type of engine for a new steamship is closely associated with the choice of a suitable propeller; in fact, the character of the service for which a ship is designed may virtually decide the choice of a propeller, and make the selection of the engine depend upon that choice. For general service, three kinds of propellers are available, the screw, the paddle and the water-jet: no other propellers have claims to serious consideration. The paddle has been in use from the earliest days of steam propulsion, the screw for about forty years, and the water-jet was first employed so long ago as 1813. The last-mentioned propeller can scarcely be regarded as having passed beyond the stage of experiment, having been adopted in several small vessels and floating fire-engines, but only in one ship of moderate size, her Majesty's ship *Waterwitch*. It has, however, attracted so much attention, and been so strongly recommended, that it cannot be left unnoticed. The paddle-wheel was the first propeller employed, and although it has now given place to the screw for ocean navigation, it still remains in common use for river and shallow-water steamers. The screw is now by far the most important propelling instrument, and there seems no present probability of any other propeller replacing it; so that it claims most attention. It is proposed to glance at the distinctive features of the other two propellers before passing to the consideration of the screw; and in order to compare their relative efficiency, it may be well to state briefly the fundamental principle of the action of all propellers.

The action of the propeller drives sternwards a stream of water, and the reaction of that stream drives the ship ahead. This reaction is measured by the sternward *momentum* communicated to the stream in a unit of time, and may be expressed as follows:—
Let C = the cubic feet of water acted upon by the propeller per

second: for sea-water weighing 64 lbs. per cubic foot, the weight of water acted upon per second must be $64C$ lbs. Let v = the sternward velocity (in feet per second) impressed upon the stream: then the magnitude of the force of reaction R is measured by the added velocity (as explained on page 135), and we must have—

$$\frac{\text{Reaction (R)}}{\text{Weight of water acted upon}} = \frac{v}{g} = \frac{v}{32.2};$$

$$\begin{aligned} R &= \frac{v}{32.2} \times \text{weight of water acted upon} \\ &= \frac{v}{32.2} \times 64C \text{ lbs.} = 2Cv \text{ lbs. (nearly).} \end{aligned}$$

This reaction measures the propelling force, or thrust of the propeller. When the ship is in uniform motion, there must be an exact balance between this thrust and the total resistance then opposing the motion of the ship. When the thrust exceeds the resistance, the motion of the ship will be accelerated; when the converse happens, the motion will be retarded. It is, however, important to note the fact mentioned above, viz. that, when a propeller acts upon the streams of water flowing past a ship, their natural flow (described in Chapter XI.) is interfered with more or less; the result being an increase in the resistance experienced by the ship. This point will be further elucidated.

From the foregoing general expression it appears that the thrust of a propeller depends upon the *quantity of water* acted upon per second and the *sternward velocity* impressed. So long as the product Cv is unaltered, so long does the thrust remain constant, no matter how C and v may be individually varied. It may be noted, however, that it is usually preferable to make the value of the velocity v as small as possible, in order to reduce the waste-work performed in giving motion to the race, and to lessen the speed at which the propeller has to be driven; so that, theoretically, it is advantageous to adopt a form of propeller which will operate upon the largest possible quantities of water. In practice this conclusion requires modification, because it may happen that in dealing with larger quantities of water, and giving the "race" a smaller sternward velocity, the increase on the "waste-work" of machinery and propellers (as explained hereafter) may more than counterbalance the gain resulting from the reduced velocity of the race. Moreover, all conditions which affect the flow of water to the propeller must exercise a sensible effect upon its efficiency. And, lastly, the

position in relation to the ship in which a propeller is placed may greatly affect its efficiency, more especially through its influence upon the stream-line motions, and the effect of those motions upon the supply of water to the propeller.*

The Water-jet Propeller.

The water-jet is the simplest of the three propellers. In her Majesty's ship *Waterwitch* it is applied in the following manner. Openings are made in the bottom of the ship to permit the passage of water into the interior. The water which enters necessarily has the forward motion of the ship impressed upon it, then passes into a turbine driven by the main engines, and is expelled, with considerable velocity, through passages leading to an outlet or nozzle placed on each side, at the level of the load-line. These nozzles direct the issuing streams sternward when the ship is to be moved ahead, and in the opposite direction when she is to go astern; arrangements being made by which the direction of outflow can be easily reversed. The sternward velocity with which the issuing streams are impressed is, of course, the difference between their actual velocity of outflow (V) through the nozzles and the speed of advance (v) of the ship. If A = the joint area of the outlets in square feet, we have—

Cubic feet of water acted upon per second = AV ;

Weight of sea-water acted upon per second = $64 AV$ lbs.

Sternward velocity (in relation to still water) = $V - v$;

Thrust: or momentum created per } = $\frac{64}{g} A \cdot V (V - v)$
 second in sea-water } = $2AV (V - v)$ lbs. (nearly).

It is important to note that the propelling effect due to the reaction of the streams issuing from the nozzles is as great when the outlets are placed above water as when they are under water, if the velocity of outflow and the speed of the ship are the same.

* Readers desirous of following out the mathematical treatment of this subject may consult with advantage the Paper "On the Mechanical Principles of the Action of Propellers," contributed to vol. vi. of the *Transactions* of the Institution of Naval Architects, by the late Professor Rankine; the re-

marks of the late Mr. Froude on that Paper, and his Paper on the "Screw Propeller" in vol. xix. of the *Transactions* should be read; also the Paper by Professor Cotterill in vol. xx. of the *Transactions*, and his Papers published in Nos. 2 and 3 of the *Annual* of the Royal School of Naval Architecture.

If the nozzles are placed above water, the turbine has to do some small amount of additional work, in raising the water-jets to the height of the nozzles before expelling them. If the nozzles are placed under water, their projection beyond the sides of the ship will cause additional resistance, especially if they are of large sectional area. In the *Waterwitch*, as stated above, the nozzles are placed at the level of the load-line.

The following points require careful consideration in making use of the water-jet propeller, if its efficiency is to be made as great as possible:—First: the arrangement of the inlets in the bottom; otherwise waste-work may be done in giving motion to masses of water which do not enter the ship. Second: the arrangement of the pipes and channels by which the jets are conducted from the inlets to the outlets; otherwise the frictional and other resistances of the water in passing through these channels may become unnecessarily great. Third: the determination of the sectional areas of the outlets, their positions, and the forms of their casings; otherwise the sectional areas of the jets may be too small to secure economical propulsion, or the passage of the casings through the water may give rise to serious resistance. Besides these matters, there are the equally important questions relating to the design of the engines which drive the turbine, and of the turbine itself; but these concern the marine engineer.

Usually, the inlets and outlets of a vessel propelled in this manner are placed amidships, where the streams produced by the passage of the ship in the surrounding water have their maximum sternward motion relatively to her. This fact may somewhat reduce the efficiency of the propeller, as compared with what its action would be if the water were undisturbed by the passage of the ship. If it be assumed that there is no such disturbance, and if the waste-work done in forcing the water through the passages be left out of account, then the following equations hold good:—

$$\left. \begin{array}{l} \text{Useful work of propeller} \\ \text{(in unit of time)} \end{array} \right\} = \text{Work done in propelling ship} \\ = \text{Thrust} \times \text{velocity of ship} \\ = 2AV(V - v) \cdot v.$$

$$\begin{aligned} \text{Total work of propeller} &= \text{Useful work} + \text{waste-work in race} \\ &= 2AV(V - v)v + AV(V - v)^2 \\ &= AV(V^2 - v^2). \end{aligned}$$

$$\text{Efficiency} = \frac{\text{Useful work}}{\text{Total work}} = \frac{2v}{V + v}.$$

Hence it follows that the more nearly V approaches v , the nearer will the efficiency approach unity. Again it will be evident that as the efficiency increases and the value of $V - v$ diminishes, the area A must be increased to maintain a constant thrust, the speed of the ship being assumed to remain unchanged; or, to state the same thing rather differently, as the efficiency increases and $V - v$ diminishes, AV the quantity of water acted upon must be increased: hence it is advantageous, under the assumed conditions, to deal with large quantities of water.

In practice, however, these conclusions need some qualification. There are, for example, various limitations to increase in the area of outlets, and the apparatus required to give the desired velocity of outflow to large quantities of water may be of a character which involves considerable losses of efficiency, while further losses of a serious character may result from the resistances to be overcome in driving such masses of water through the passages in the interior of the ship. In fact it may happen that, taking into account the efficiency of the whole propelling apparatus, a less quantity of water and a higher velocity of ejection may be preferable to the conditions which the hypothetical case discussed above would indicate as most favourable to efficiency. In the trials made with jet-propelled vessels, this feature of the subject has not received very careful consideration, so that a definite opinion cannot be formed. It seems probable, however, that the velocities of ejection have been too high in relation to the speed of the ship to favour efficiency; the quantities of water operated upon being too small. In the trials made the results have been dealt with in the aggregate, and mostly in the way of a rough comparison with results of speed-trials made with vessels of similar form and size driven by screw propellers. Hitherto, so far as we are aware, there has been no exhaustive scientific analysis, including the tow-rope resistance and "effective horse-power" (see page 518) of a jet-propelled vessel, which would enable the ratio of the effective horse-power to the indicated horse-power to be ascertained, and compared with corresponding ratios for vessels driven by screws or paddles. Until such an analysis is made, the true relative efficiency of jet-propellers cannot be determined.

Meanwhile, using the best information available, there is good reason for considering the jet-propeller distinctly inferior in efficiency to screws. The *Waterwitch*, for example, was tried against two twin-screw vessels, the *Viper* and *Vixen*, of equal length and beam with her, of similar form in the forebody,

but not nearly so well shaped aft, the twin-screws being carried by double deadwoods and thus involving increased skin friction, as well as eddy resistance, as compared with the *Waterwitch*. The *Viven* was a composite vessel: the other two were iron-hulled. Comparing the *Viper* and *Waterwitch* the following results were obtained on the measured mile. For the *Viper*, with displacement of 1180 tons, and 696 indicated horse-power, a speed of 9.6 knots: for the *Waterwitch* with displacement of 1160 tons, and 760 horse-power, a speed of 9.3 knots. This inferior performance of the jet-propeller must be attributed partly to the waste work in forcing water through the passages, and partly to the comparatively small quantity of water acted upon. The joint sectional areas of the nozzles in the *Waterwitch* amounted to $5\frac{1}{3}$ square feet; and at full speed about 150 cubic feet of water was delivered per second. The twin-screws of the *Viper*, on the other hand, operated on more than 2000 cubic feet of water per second.

Experiments have been made with the *Waterwitch* to test the effect of *reducing* the sectional areas of the nozzles, and the results obtained indicate some decrease of efficiency as compared with the performances with full-sized nozzles, just as might be expected from the general considerations stated above. No experiments have been made with nozzles enlarged beyond the sectional area of $5\frac{1}{3}$ square feet, which has been shown to be proportionately very small. Considerable changes would have been required in the ship before this enlargement of the nozzles could be effected; but there is every reason to believe that in any future jet-propelled ship fitted with turbines it would be found advantageous to adopt nozzles of greater size, and to reduce the velocity of outflow of the jets.

Another very interesting comparative trial has been made in Sweden on two torpedo-boats of about 23 tons displacement and of identical form, with boilers of the same size and type. One of the boats was driven by twin-screws, and the other by water-jets to which motion was given by centrifugal pumps. The twin-screw boat attained $9\frac{1}{2}$ knots with 80 indicated horse-power: while her jet-propelled rival attained 8 knots with rather more indicated horse-power. It is probably no exaggeration to say that to increase the speed of such a boat from 8 to $9\frac{1}{2}$ knots would require from 60 to 70 per cent. increase in power. Hence it will be seen that the screws in this trial showed an enormous superiority over water-jets.

A jet-propelled vessel, with turbine, has also been built for

the German navy. She is said to be about 170 tons displacement, and to have attained a speed of 7 knots with 292 indicated horse-power. In this case we are unable to give a comparison with a screw ship of similar form and power.

The latest and most novel experiment in jet-propulsion has been made recently in Germany by Dr. Fleischer, in a vessel named the *Hydromotor*, 110 feet long, 17 feet beam, and with a mean draught of $6\frac{1}{4}$ feet, her displacement being 105 tons.* It is claimed for this vessel that with 100 indicated horse-power she attained a speed of 9 knots; but we are not furnished with particulars of the conditions under which the speed-trials were made, and these conditions may have differed from those usual in English measured mile trials, where all possible care is taken to determine accurately the true mean speed and to eliminate the influence of wind and tide. Apart from the reported performance there are, however, many features of great interest in this vessel. There is no centrifugal pump, but the steam acts directly upon the water in two reservoir cylinders placed above two large pipes leading to the nozzles, which are situated nearly amidships on either side of the keel. In each cylinder there is a "float" or piston of nearly the same diameter as the cylinder, and with a closed spherical top. When the cylinder is full of water this float is at the upper part of the cylinder; when steam is admitted into the top of the cylinder it presses the float down and expels the water at a high mean velocity. After a certain portion of the stroke has been made the admission of steam is shut off automatically, and the rest of the stroke is performed by the expansion of the steam, the velocity of ejection decreasing as the float approaches the bottom of the cylinder. The exhaust valve to the condenser is then opened, and as the steam rushes out from above the float a vacuum is formed, and the water enters the cylinder partly through the ejecting nozzle and partly from a separate valve communicating with the water-space of the surface condenser. The float is thus raised again to the top of the cylinder, after which the operations described are repeated. In the *Hydromotor* there are two cylinders working alternately: Dr. Fleischer proposes in larger or swifter vessels to

* For particulars see the two pamphlets entitled *Der Hydromotor* and *Die Physik des Hydromotors* by Dr.

Fleischer. Kiel 1881. See also *Engineering* of September 9, 1881.

use a large number of similar cylinders in order to obtain the necessary thrust. The cylinders are placed as high as convenient in the vessel, so that the vacuum produced by the exhaustion of the steam may be utilised in raising a volume of water above the sea-level, and thus adding an effective "head" of water to the steam pressure during the down stroke. In the *Hydromotor* the mean speed of outflow is said to have been 66 feet per second, rather less than 12 cubic feet of water being expelled per second.

This general sketch of the principal features of the new system must suffice. It will be seen to be very simple, to avoid the waste-work of the engines used to drive centrifugal pumps, and to lessen very much the resistances incurred in driving the water from the pumps to the nozzles. On the other hand, there must be losses from condensation of steam in the cylinders; but these are wood-lined, and it is asserted that the losses are not serious. The velocity of ejection is high, reckoned as a mean, and it is variable during the stroke; while the quantity of water operated upon is small; neither of which conditions favours efficiency. We are not in possession of sufficient trustworthy information to enable an analysis to be made of the performances of this vessel as compared with other jet-propelled ships or with screw steamers. Dr. Fleischer claims for her a ratio of useful to total work of 34 per cent. at full speed. This is below the efficiency usually obtained in screw steamers at full speed, and much below that in many such steamers (see page 579). But it should be noted that there are no records of dynamometric towing experiments with the *Hydromotor*, so that the efficiency claimed for her is probably an estimate. Without pronouncing any opinion on the merits of this novel and ingenious system of propulsion we must now pass on; but the particulars here given may be of value, and the further trials with the system will be carefully watched by all persons interested in steam navigation.

It has been urged by the advocates of jet-propellers that even though they should prove less efficient than screws or paddles, they should be adopted for vessels of war, because they have the following advantages:—First, that they cannot be so easily damaged in action or fouled by wreckage as the other propellers; secondly, that they give greater control to the commanding officer in managing the machinery; thirdly, that they give increased manœuvring power; fourth, that they can be used as pumps to clear a ship rapidly of large masses of water in cases of

accident or damage. The first and second claims may be admitted, respecting the third, reference may be made to Chapter XIV. As to the fourth, it is only necessary to remark that the efficient realisation of this idea in minutely subdivided war-ships would practically jeopardise that subdivision, the maintenance of which is of far greater importance to the safety of a ship than any possible increase in pumping power.* Jet-propellers are undoubtedly well adapted for special vessels, such as floating fire-engines, where pumping power has to be provided, as this power can also be made available for propulsion.

Paddle-Wheels.

Paddle-wheels, like jet-propellers, give direct sternward momentum to streams of water, the reaction of which constitutes the thrust or propelling force. These streams form what is termed the "paddle-race:" and their cross-sectional areas depend upon the area and immersion of paddle-floats. "Feathering" paddle-floats are now generally employed; the common paddle-floats being fixed radially upon the wheels. The *speed* of the floats depends upon their radial distance from the centre of the wheel and the number of revolutions of the wheel in a unit of time. Suppose the centre of the floats to be 16 feet from the centre of the wheel, and the wheel to make 16 revolutions per minute, then speed of floats in feet per second (V) would be given by

$$V = \frac{2 \times 3.1416 \times 16 \times 16}{60} = 26.8 \text{ feet (nearly).}$$

If the speed of the ship is called v , the difference ($V - v$) between that speed and the speed of the paddle-floats is termed the *slip* of the paddles, and is usually expressed as a fraction of V , or

$$\text{Slip (per cent.)} = \frac{V - v}{V} \times 100.$$

Suppose in the example chosen—which is taken from an actual

* See a Paper "On the Pumping arrangements of Modern War-ships," contributed by the Author to the

Journal of the Royal United Service Institution for 1881.

ship—that the speed v is 22·4 feet per second (about 13 knots per hour):

$$\text{Slip (per cent.)} = \frac{26\cdot8 - 22\cdot4}{26\cdot8} \times 100 = 16\frac{1}{2} \text{ (nearly).}$$

From 20 to 30 per cent. appears to be a fair average for the slip of paddle-wheels when working under favourable conditions: in some cases even a greater slip occurs. Being usually placed amidships, they operate on water which has its maximum sternward velocity relatively to the ship, and this fact somewhat reduces the efficiency. With a certain speed of revolution it lessens the sternward momentum which the floats can impress upon the paddle-race. With a certain indicated power, the speed of the paddle-wheels may be increased in consequence of working in the disturbed water, but the waste-work on the engine, friction, “churning” of the water, &c., will be also increased; so that there must be less efficient action than if the paddle worked in still water. If the motion of the water be disregarded, and the paddles assumed to operate on water which is undisturbed by the passage of the ship, it is possible to express the thrust of the propeller in a simple form. Let A = cross-sectional area of the paddle-race on both sides; then, if V and v have the same values as in the preceding equations for slip of paddle-wheels,

Cubic feet of water acted upon per second = $A \cdot V$;

Thrust: or momentum created per } = $2AV(V - v)$ lbs. nearly;
 second in sea-water }

the exact determination of A is not an easy matter. With the common or radial float it is generally supposed to equal the product of the length (or transverse measurement) of the floats into their maximum depth of immersion; whereas with feathering floats it is assumed equal to the area of the float. Certain rules have been established by experience for fixing the size of the paddle-wheels, the length of the floats, their breadth, and maximum immersion. Mr. Scott Russell summarises these rules as follows: *—The size of the paddle-wheel should be determined by considering the intended speed of the ship, the average slip of the paddles in similar vessels, and the number of revolutions

* See his work on *Naval Architecture*.

per minute considered most suitable for the engines.* The height of the paddle-shaft and of the engines in the ship should also be noted, in order to determine their effect on the stability. In the fully laden condition of the ship the wheel should not be buried in the water more than one-third to one-half its radius; in the light condition the upper edges of the paddle-floats should be at least six inches under water when they are vertical. The length (or transverse measurement) of the floats should not exceed one-third or one-half the breadth of the ship except in special cases. In a radial or common paddle-wheel the number of the floats should about equal the number of feet in the diameter; and the breadth of the floats should be about $\frac{3}{4}$ inch or 1 inch for each foot in the diameter. In a feathering paddle the floats should be about one-half as numerous and twice as large as the floats in a common paddle-wheel. These are only approximate rules for deep-water steamers; for shallow-draught vessels these rules would not be followed, but the special conditions on which a vessel was to be employed would be considered.

The chief practical difficulty with paddle-wheels applied in large sea-going steamers was connected with the variations in their performance produced by changes in the draught of water and the immersion of the floats. In performing a long voyage, the consumption of coals and stores might produce a change of draught amounting to several feet; and the paddle-floats which were too deeply immersed to be most efficient when the voyage began, might not be sufficiently immersed when it ended. When variations in draught are not considerable, the voyages being short, and the changes in the weights small, paddle-wheels can be employed with the greatest success. Rolling motions, of course, greatly affect the action of paddles in ships at sea, and not merely influence their propelling effect, but give rise to serious straining actions upon the propelling apparatus. A paddle-wheel at one instant submerged far below its normal depth, and having its revolutions retarded by the change, might a few seconds after, on the roll of the ship in the opposite direction, be lifted almost clear of the water and "race" violently

* From the comparison of a great number of high-speed paddle steamers, we find that from 20 to 30 revolutions per minute were common, in some cases 40 to 45 revolutions were made, and in others as many as 70 revolutions. In fact, no rule can be laid down for the revolutions.

beyond the normal speed. In smooth water no similar disturbances of the regular action of paddles occur; and they are there applied with the greatest advantage.

Paddle-wheels, notwithstanding their direct sternward action on the water, do a considerable amount of waste-work, besides that which is effective in propelling a ship. This waste-work consists in overcoming the resistance offered by the water to the entry and exit of the floats, and in "churning" the water—driving it in other than the sternward direction, delivering blows, &c. Various devices have been proposed for lessening this waste-work, feathering paddles being the most common. Mathematical investigation shows that, with the best paddle-wheels, the waste-work at least equals the work done in giving sternward motion to the paddle-race.

The action of the paddle-floats must exercise some influence upon the stream-line motions of the water past the ship, and consequently affect the resistance. The water in the paddle-race would, if the ship were towed, close in around the stern, and probably have some small motion in the direction of her advance, forming a "wake"; but by the action of the paddles it is driven astern with a considerable velocity, and this change must be equivalent to an increase in the resistance experienced by the ship when self-propelled, as compared with the resistance measured by a tow-rope strain. It is, however, to be noted that the paddles would rarely, if ever, be immersed to more than one-third or one-half of the draught of water, so that the disturbance of the stream-line motions may not extend to the greater portion of the water surrounding the ship and at any instant affected by her motion.

The "augment of resistance" due to the action of paddle-wheels has been made the subject of experiment at Amsterdam by Dr. Tideman.* His experiments were conducted on models, both of ships and paddle-wheels, and the results are interesting; but the trials were not sufficiently numerous or exhaustive to be conclusive. These trials indicate considerable variations in the ratio which the augment of resistance bears to the tow-rope resistance; both for a particular model moving at different speeds, and for different models moving at an identical speed. In the case of one model, paddles, a single screw and twin-screws were tried; and the paddles caused a greater augment of resistance

* See the Report in the *Memorial van de Marine* (9^e Aflevering): Amsterdam, 1878.

than the screws. It must not be supposed, however, that this always holds good; and further experiments in this direction can alone enable a correct judgment to be formed. Except as a matter of scientific interest, such experiments are not likely to be made: since paddles are only used, at present, in special classes of ships, where the screw cannot be conveniently employed.

Comparing paddle-wheels with water-jets, delivered by centrifugal pumps as in the *Waterwitch* and other vessels, it appears that the waste-work of paddles is probably not greater than, if so great as, that of jets, when allowance is made for the frictional resistances experienced by the water in passing from the inlets to the nozzles. Paddle-floats, moreover, can be made much larger than can the sectional areas of nozzles without serious practical inconveniences. Hence, on the whole, paddles are commonly preferred to jets, and they are equally applicable even in the shallowest waters, except, perhaps, in cases where very narrow channels have to be navigated; but even under these special circumstances the paddle is commonly used, being placed astern instead of amidships. When paddles are fitted so that they can be disconnected, and the wheels on opposite sides of a ship worked in opposite directions, they give as great manœuvring power under steam as water-jets; besides being more efficient propellers. On the other hand, paddles are more liable to injury than the nozzles for water-jets: and this difference is of special importance in war-ships.

As compared with the screw-propeller, paddle-wheels are distinctly inferior for general sea service for the reasons given on page 540. In smooth water trials the paddle does not compare so badly with the screw, and is thought by some authorities to be about equal to the screw in efficiency, although this opinion is open to question. For shallow-draught vessels of high speed the paddle-wheel is usually better adapted than the screw. Paddle steamers have also attained some of the highest speeds yet reached on the measured mile. Her Majesty's yacht *Victoria and Albert* steamed at a speed of 17 knots; the Holyhead packets attained $17\frac{3}{4}$ to 18 knots; the Channel steamers recently built attained $18\frac{1}{2}$ knots, and so did the *Mahrousse*, a paddle yacht built in this country for the Viceroy of Egypt. All these speeds are very high, even when compared with the measured mile speeds of most of the finest screw steamers in existence. They are only exceeded by the speeds of special vessels like the *Iris* and *Mercury* of the Royal Navy, and those of the torpedo-boats.

The Screw-Propeller.

Before proceeding with the discussion of the special features of screw-propellers, it will be desirable to explain a few of the terms that will be frequently employed. The *diameter* of a screw is measured from the circle swept by the tips of its blades during their revolution; the area of this circle measures the *screw-disc*. The *pitch* of a screw is the length of a complete turn measured parallel to the axis; in other words, it is the distance which the screw would advance in one revolution if it worked in a solid nut. The *speed* of a screw is the distance it would advance in a unit of time if it worked in such a nut, and is clearly equal to the product of the number of its revolutions, in that unit of time, by the pitch. The difference between the speed of the screw (say, V feet per second) and the speed of the ship (v feet per second) is usually termed the *slip* of the screw, and expressed as a percentage of the speed of the screw. For example, a screw of which the pitch is 14 feet makes 72 revolutions per minute, and drives a ship 8.2 knots per hour: required the slip.

$$\text{Speed of screw} = V = \frac{72 \times 14}{60} = 16.8 \text{ feet per second.}$$

$$\text{Speed of ship} = v = 8.2 \times 1.688 = 13.8 \text{ ,, ,, ,,}$$

$$\text{Slip (per cent.)} = \frac{V-v}{V} \times 100 = \frac{3}{16.8} \times 100 = 17.85.$$

This slip ($V-v$), if the screw worked in water undisturbed by the passage of the ship, would clearly be the sternward velocity relatively to still water of the particles in the propeller race. In practice, however, the screw works in water which has been disturbed by the passage of the ship; and hence, strictly speaking, the slip ($V-v$) should be termed the *apparent slip*. The *real slip* may be defined as the total change in the velocity of particles in the race produced by the action of the propeller. The passage of the ship produces a forward motion of the surrounding particles, and forms a wake (as explained in Chapter XI.), in which the screw works; it then has to destroy this forward motion before it can impress a sternward motion, relatively to still water, upon the race; but the apparent slip takes account only of that sternward motion, and hence may differ considerably from the real slip. In some cases the curious phenomenon of apparent

“negative slip” is observed, the speed of the screw being less than that of the ship; but more commonly the apparent slip is positive, and varies from 10 to 30 per cent., 20 per cent. being the average in very many cases.

The theoretical investigation of the action of a screw-propeller involves many serious difficulties. The curved helicoidal surfaces of the blades are set obliquely to the line of motion, and consequently communicate rotary as well as sternward motion to the water in the screw-race. The thrust of a screw-propeller is measured, of course, like that of a paddle or jet, by the *sternward momentum* generated in the race during a unit of time; but while this principle is accepted, its application to the estimate of the actual thrust of a particular screw necessitates certain assumptions and the use of data obtained experimentally. Moreover, the determination of the *efficiency* of a screw-propeller requires, as was shown in the case of a jet, a determination of the ratio of the useful work done by the propeller to the total work; and here again difficulties arise. As a screw revolves and communicates motion to the race, its surfaces experience frictional resistances from the surrounding water, which frictional resistances lessen the effective thrust, and increase the work which has to be done in turning the screw. Besides this, the rotary motion given to the water must be accompanied by some centrifugal action and by a diminution in the pressure of the screw upon the water, resulting in a decrease of thrust. Nor can the question of the supply of water to the screw, as affected by its position and the form of the stern of a ship be overlooked, while the “augment of resistance,” due to the action of the screw, is a matter of the utmost importance. All the foregoing difficulties exist even when the form, size, area, and number of blades, and other particulars are assumed to be known for a screw-propeller; but in practice these features also require to be determined, and upon that determination the efficiency of the screw will largely depend.

This enumeration of the difficulties surrounding an investigation of the efficiency of screw-propellers has not been put forward as a justification of the view which has been sometimes expressed that any such theoretical investigation must be of little value, but rather as an explanation of the fact that no general theory has yet found acceptance, notwithstanding the labours of many eminent writers on propulsion. Amongst these writers the late Professor Rankine and the late Mr. Froude stand pre-eminent; a

brief sketch of their methods of procedure may therefore be of interest.*

Professor Rankine assumed as the basis of his investigation that the number and surface of the blades in a screw would be adjusted by rules derived from practical experience, so that the whole cylinder of water in which the screw revolved should form a stream flowing aft; that is to say, the race was assumed to consist of a cylindrical column of water having the screw disc, less the sectional area of the boss, for its athwartship section, the flow of water to the screw being supposed to be ample. The motion of the particles of water in this race was supposed to be of a spiral character, and the particles at a given radial distance from the axis of the screw were assumed to have identical motions impressed upon them by the action of those portions of the screw blades which would be cut off by the cylinder having the same distance as its radius and a very small thickness. Hence it followed that the race could be imagined to be made up of a series of concentric hollow cylinders, "each having a rotatory motion and a sternward motion: these motions would be, in general, different for each cylinder, so that they would slide through each other and rotate within each other." On these assumptions it was possible to approximate (1) to the quantity of water acted upon by the screw in a unit of time; (2) to the sternward momentum generated in a unit of time, which measured the thrust, if friction were neglected; (3) to the loss of thrust and increase of waste-work due to the friction of the screws; (4) to the effect upon the efficiency of the screw produced by its action in water which had been disturbed by the passage of a ship. All this Rankine did in a manner worthy of his high reputation, and his investigation will always maintain its value as the first attempt in a new direction. Further, he gave examples of the application of his formulæ to the numerical calculations for the screws of actual ships. In accordance with his fundamental assumptions he determined approximately the *disc area*, or diameter, for the screw appropriate to any ship, but did not

* See Professor Rankine's Paper "On the Mechanical Principles of the Action of Propellers," in vol. vi. of the *Transactions* of the Institution of Naval Architects; and Papers by Mr. Froude in vols. vi., viii., and xix.

of the *Transactions*. For an excellent summary and extension of Rankine's method see also a Paper "On Screw-Propellers," by Professor Cotterill in No. 3 of the *Annual* of the Royal School of Naval Architecture.

attempt to fix the areas or numbers of the blades, leaving them to be determined by deduction from experience. It will be obvious, however, that in this determination of the forms and numbers of the blades necessary to give motion to a complete cylindrical column of water lies a great practical difficulty, and hence it followed that this masterly investigation had little influence on practice.

The investigation of the efficiency of screw-propellers made by the late Mr. Froude proceeded on entirely different lines from those followed by Professor Rankine. Mr. Froude began by a consideration of the frictional and normal resistances experienced by a plate moved obliquely through water (see page 436), making use of the results of experiments conducted by Colonel Beaufoy and himself, as well as of the mathematical investigations of Lord Rayleigh. He then traced out the analogy between the motion of such a plate and a small portion or element of the area of a screw surface, which is set obliquely to the plane of rotation and made to revolve around the axis of the screw. For such an element (or unit of area) of the screw surface, the normal pressure and frictional resistance were estimated, as if it alone were acting on the water, allowance being made for the angle of obliquity, the speed of rotation, the speed of the ship, and the true slip. In this manner the propulsive force or longitudinal thrust for each element of area, and the transverse component of the forces operating on it, were ascertained. The effective work done is, as before explained, that expended in overcoming the ship's resistance through the distance she advances in a unit of time; the total work done is that expended in overcoming the transverse component of friction and normal pressure through the distance the element of area travels in its circular path in the same unit of time. In his published paper Mr. Froude confined his mathematical formulæ to one such unit of the screw surface, and did not attempt to integrate the expressions so as to represent the varying radial distances and obliquities of the elements making up the whole screw surface. This fact must be borne in mind in considering the conclusions stated below, for it is obvious that the aggregate effect of the total surface of a screw-propeller must differ from the summation of the effects of each unit of area estimated on the hypothesis that it alone is acting. That hypothesis assumes that the momentum generated per unit of time is due to the action of the unit of area upon water which would be undisturbed but for its action, whereas most of the corresponding units of area in a screw surface must come into

operation upon water which has been disturbed by the action of adjacent portions of the area. Moreover, it is clear that in a propeller with two or more blades there may be interference of the action of one blade with another, as well as the interference just mentioned of adjacent portions of the same blade. This disturbing element in the problem can only be dealt with at present experimentally.

Reverting to Mr. Froude's investigation, it may be added that he virtually assumed in his mathematical formulæ the whole screw surface to be converted into an equivalent plane area with a constant angle of obliquity. For the main purpose he had in view this assumption was permissible, although not strictly accurate. He chiefly desired to show that increase in the diameter and surface of screw-propellers, although it enabled a larger quantity of water to be operated upon, might be accompanied by such an increase in the waste-work of frictional and edgeway resistance as would make it preferable, on the whole, to use screws of less diameter and surface, but greater pitch. And it must be admitted that this lesson was much needed at the time. Another point which should be noted with reference to Mr. Froude's investigation is the omission of any attempt to express the influence which the stream-line motions and frictional wake may have upon the performance of a screw placed at the stern of a ship. In other papers Mr. Froude had most ably outlined the great features of that influence; but in this paper he only alluded to its importance, and to the complex nature of the phenomena.

It now remains to add a brief summary of the principal deductions made by Mr. Froude from his mathematical investigation; they are as follow:—First, for maximum efficiency the mean effective angle of the screw-blade measured from an athwartship plane, or "pitch-angle," should be 45 degrees; which is obtained when the pitch is about twice the extreme diameter. Second, for maximum efficiency the slip-angle must vary directly as the square root of the coefficient of friction, and inversely as the square root of the coefficient of normal pressure, which gives a slip of about $12\frac{1}{2}$ per cent., with the values of the coefficients adopted in the investigation. This is the *real slip*; the *apparent slip* will usually be less, and will vary according to the amount and character of the disturbance of the water in which the screw works. Third, that for maximum efficiency the area of the screw-blades may be expressed approximately by the formula.

$$\text{Area (in square feet)} = 8.9 \times \frac{R}{v^2};$$

where R = the resistance of the vessel (in pounds) at her maximum speed.

v = her maximum speed (in feet per second).

Fourth, that since at moderate speeds the resistance of a ship varies as the square of her speed, the same propeller should, within those limits of speed, drive a ship with the same percentage of slip; but that outside those limits of speed the percentage of slip should increase. Fifth, that for moderate speeds, if the blade-areas of the screws of two similar ships have the ratio of the squares of the respective dimensions, the percentage of slip should be the same. Sixth, that, if two ships have the same resistance at different speeds, the area of screw-blades which will overcome the resistance while maintaining a given slip, will be less, in the ratio of the squares of the speeds, for the ship which has the higher speed. The last three deductions are obtained from the formula for blade-area given above. Seventh, that the maximum efficiency which can be realised under the most favourable conditions is about 77 per cent.; but that the percentage of slip might be increased considerably (even as high as 30 per cent. with the screw working in undisturbed water) without any serious decrease of efficiency in screws of ordinary proportion.

Limits of space prevent us from making any comparison between the results of steamship trials and these deductions. It cannot be doubted, however, that this new departure, and the numerous trials with model screws made by the late Mr. Froude, and since his death by Mr. R. E. Froude, will result in very considerable extensions of our knowledge of the action of screw-propellers. Experimental investigations of this nature, made with the ingenious apparatus devised by Mr. Froude, by which the greatest accuracy of observation is secured, and supplemented by mathematical analysis, will probably do much more to advance our knowledge than any theoretical investigation. But, to make such model experiments of the fullest value, the results must be carefully compared with the performances of similar full-scale screws in actual ships.

In concluding these remarks on the theory of the screw-propeller, allusion must be made to the valuable labours of Professor Cotterill, who has shown how the two methods of Rankine and Froude are related to one another, and under what

circumstances they will yield identical results. His Memoir on this subject, mentioned on page 532, will well repay the perusal of all who are engaged in steamship design.

Passing from this branch of the subject it may be well to glance at some important features of screw-propulsion, which have been certainly ascertained and have great practical interest. In the majority of screw steamers there is a single-screw, placed in an aperture between the body of the ship and the sternpost to which the rudder is hung. In a few cases the single-screw has been placed abaft the rudder, no aperture being requisite. Twin-screws, one under each counter, have been largely employed in war-ships during the last ten or twelve years; in merchant ships their use has hitherto been rare, except in cases of shallow draught, but several ocean-going steamers have been constructed recently with twin-screws. A singular arrangement of twin-screws has been adopted in some river steamers. For the purpose of bringing the shafts closer together, the screws have been placed with a short longitudinal interval between them, and the circles swept by their inner tips have overlapped. This can scarcely have favoured efficiency. Another method of using two screws, adopted in the cigar-ships and in certain tug-vessels, has been to run the shaft throughout the length, and to have a screw at the bow as well as at the stern; the primary object in this arrangement may be supposed to be the power of rapidly reversing the course without turning. In some ferry-steamers a similar arrangement has been made with two continuous shafts, each with a bow and stern screw. A few instances occur where an annular shaft rotates round a solid shaft, the two working in opposite directions, and each carrying its own screw-propeller. This is the arrangement adopted in submarine locomotive torpedoes. Multiple screws have also been used in special cases. Some of the shallow-draught vessels built for service on the Mississippi during the American Civil War had four screws; the Russian circular ironclads were fitted with six screws, and the imperial yacht *Livadia* has three screws. Of all these varied arrangements of screw-propellers we propose only to consider two, viz., the single and the twin-screw systems.

One condition essential to the efficiency of all arrangements of screws is that they shall have a good supply of water, in order that the race may have its full sectional area. Amongst the more important circumstances influencing the supply of water to the screw may be mentioned the form of the stern of the ship, the dis-

tance of the screw abaft the stern, and the immersion of the upper blades when they are passing through the vertical position. If the screw is not sufficiently immersed, it will create considerable surface disturbance, have a less compact and well-defined race, and do more waste-work. If the stern is bluff or very full, the efficiency of a single-screw will be decreased because the water cannot flow freely to certain parts of the screw-disk, which are masked by the sternpost and body of the ship. If the screw is close under the stern, as it usually is in single-screw ships, it has to act at some disadvantage as compared with what it would have to do if placed further astern. Fineness in the "run" of single-screw steamships is now recognised as a desirable and necessary feature. In the earlier periods of steam-propulsion, this was not so well understood, and in many of the bluff-sterned vessels of the Royal Navy, converted from sailing into steamships, the prejudicial effect of their forms on the action of the screw was most marked. One case alone can be cited out of the many on record. The screw-frigate *Dauntless*, built in 1848, was first tried with a full stern, and her performance being unsatisfactory, she was lengthened aft about 10 feet, and made of much finer form in the run. In her earlier trials, when the displacement was 2300 tons, she was driven at a speed of 7.3 knots with 836 horse-power (indicated). After the alteration, with the same screw and nearly the same displacement, the ship attained a speed of 10 knots with 1388 horse-power; but had the form remained unaltered the engine-power for that speed would have been at least 1900 horse-power. The alteration of the stern and consequent decrease in resistance, as well as the better supply of water to the screw may be assumed therefore to have effected a saving of no less than 30 per cent. in the power.

From the remarks made above it will have been seen that screw-propellers placed near the stern of a ship must cause a more or less considerable "augment" of the resistance which that ship would experience if towed. Under the latter circumstances the stream-lines (as explained on page 445) close in around the stern and produce a forward pressure, which counterbalances to a large extent the sternward pressure of the streams upon the bow. But when rapidly-revolving screws are placed close to the stern, and made to give sternward momentum to large quantities of water, there is a lessened forward pressure on the stern, and a consequent increase in the resistance. The proportionate amount of the augment is governed by various considerations, and therefore has widely different values in different ships. Most of

our exact information on this subject is due to the experimental researches of the late Mr. Froude; Dr. Tideman in Holland and Chief-Engineer Isherwood in America having added some useful *data*. In single-screw ships with the screws before the rudder-post, the augment is said to have varied from 20 to 45 per cent. of the tow-rope resistance; the highest values occurring in wood or composite ships with thick rudder-posts and rudders. These rudder posts, &c., are found to represent about 10 per cent. of the tow-rope resistance in some cases. If the single-screw is carried abaft the rudder the augment is considerably reduced. In fact Mr. Froude stated, as the result of direct experiment that, with a single-screw placed one-third or one-fourth of the extreme breadth of a ship clear of the stern, the increase of resistance produced by its action was only one-fifth of that produced by the screw in its ordinary position. No screw has been placed so far aft as this in an actual ship, nor is it likely to be so placed on account of the risks involved; there can be no question, however, that for efficiency as a propeller the position abaft the rudder is usually to be preferred. Trials made in torpedo-boats confirm this statement, although the difference in efficiency is not very great, and for the sake of greater handiness it is preferred to place the rudder abaft the screw.

Dr. Tideman's results are contained in the publication mentioned on page 541; they are numerous and interesting, showing considerable variations in the augment with ships of different form. This broad conclusion is confirmatory of the experiments made by Mr. Froude, wherein it appeared that different degrees of fulness in the "run" or after part of a ship immediately before the screw very sensibly influenced the augment of resistance. It would appear that Dr. Tideman did not use rudder-posts, &c., in his trials with single-screws; and this would necessarily affect the values given by him as compared with those above stated for single-screws.

The trials made by Chief-Engineer Isherwood, U.S.N., were conducted on a steam-launch about 54 feet long, and are excellent examples of what might be done, on a larger scale, in the record and analysis of steamship performance.* In order to determine the resistance of the launch it was towed, at various speeds, with no screw attached, the tow-rope strain being measured by a dynamometer. Other trials were made with screws of different sizes and shapes, the thrusts corresponding to

* See the Report of the Secretary of the United States navy for 1874.

various speeds being measured by a dynamometer mounted on the shaft. The materials were thus obtained for a comparison of the tow-rope strain with the thrust of the screw-propeller at different speeds; and although the experiments are not exactly correspondent to those of Mr. Froude and Dr. Tideman, owing to the screw being attached to the vessel, the difference is not important. The tow-rope strain for a speed of 7.5 knots was found to be about 725 lbs.; the corresponding thrust being 867 lbs. or about 20 per cent. greater than the tow-rope strain. At lower speeds the thrust was not nearly so great in proportion to the tow-rope strain.

For twin-screws fitted in the usual manner under each counter, there are *a-priori* reasons for anticipating that the augment of resistance will be less in ships of good draught, than with single-screws fitted in the ordinary manner. These screws are carried some distance clear of the body of the ship; and there is nothing to prevent the free flow of water to them unless the supports to the outboard portions of the shafts are badly arranged. In deep-draught ships the screws are well immersed, and their sweep leaves untouched a considerable part of the streams flowing past the ship near the region of the water-line, where the form is fuller than below. In vessels of very shallow draught these conditions may not hold good; but then single-screws are frequently not applicable, and the choice lies between twin-screws and paddles. These general conclusions are borne out by the few experiments made by the late Mr. Froude on models of twin-screws, which show that they cause a less augment of resistance than single-screws placed in the ordinary manner. In the case of the *Iris*, for example, the augment was about 10½ per cent. of the tow-rope strain. It is probable, moreover, that with increased fulness of form in the run the advantage of the twin-screws in this respect would be increased; but further experiments are needed to settle this matter.

Dr. Tideman has also made experiments on the augments of resistance produced by single and twin-screws carried behind the same model. These experiments show a marked inferiority in the augment caused by the single-screw; and therefore do not agree with the experiments made at the Admiralty Experimental Works. We are not in possession of all the facts as to the Amsterdam experiments; but it would appear that the single-screws were tried without any rudder-post or rudder behind them, which has been shown to be a great advantage, and that the Dutch method of supporting the outboard portions of the

shafts in twin-screw ships is less favourable to the action of the screws than the corresponding method in the English ships. Without in the least desiring to express any doubt of the accuracy of the results obtained by Dr. Tideman, we therefore attach the greater value to those obtained by Mr. Froude, as representative of English practice. And this opinion is supported by the comparative performances of single and twin-screw steamers to which reference will be made hereafter. In the Imperial Russian yacht *Livadia*, the augment of resistance produced by the action of her three screws is said to have been 22 per cent. of the tow-rope resistance.

In order that the best results may be obtained with twin-screws, great care must be bestowed upon the arrangement and shaping of the struts, tubes, &c., supporting the outboard portion of the screw-shafts. Otherwise very considerable eddy-making resistance may be caused; and the nett resistance of the hull proper—stripped of these excrescences—may be increased by a large percentage, which would balance, or perhaps exceed, the diminished augment due to the action of the screws. With care, however, this adventitious resistance may be avoided for the most part; and the simple rules to be followed have already been stated on page 449. It may be added that as the sizes and nett resistances of ships increase, the relative importance of the resistances of struts, &c., diminishes; but this is no reason for treating them as unimportant even in the largest ships.

Any comparison of single and twin screw-propellers would be incomplete which did not take account of their relative advantages of position as regards the "frictional wake" of a ship. Mr. Froude first drew attention to the influence upon economical propulsion which might result from the utilisation of some of the *vis viva* of this wake by the screw; and other writers have since amplified his treatment of the subject.* This frictional wake must be distinguished from the forward motion of the stream-lines at the stern described on page 445 for a frictionless fluid. The actual wake of a ship, of course, combines the stream-line motions with those due to the frictional drag of the skin upon the water; but attention is now devoted exclusively to the frictional wake.

* See Papers by Mr. Froude in the *Transactions* of the Institution of Naval Architects for 1865 and 1867; and a Paper by Professor Osborne Reynolds in the *Transactions* for 1876. The Author

also desires to acknowledge his obligations to Mr. R. E. Froude for more recent experimental *data* on this subject.

The momentum of that wake has already been reckoned in the resistance of the ship; and were there no propeller at work—as is the case in a sailing ship—the water in the wake would continue to move forward after the passage of the ship, until by its dispersion over larger quantities of water and its degradation by resistance from adjacent masses of water, the motion gradually disappeared at some distance abaft the ship. Hence it will be evident that a single-screw revolving close to the stern of a ship, and pervading in its motion a considerable portion of the sectional area of this frictional wake, may utilise some of its *vis viva*, and gain in effective thrust. Twin-screws, on the other hand, being carried clear of the body of the ship, do not have a similar opportunity of gaining in effective thrust; and this tells against their relative efficiency. To what extent this advantage of single-screws compensates for their greater augmentation we are not yet in a position to decide.

Still another feature affecting the relative efficiency of single and twin-screws is the unequal forward motion of the wake at different depths. Speaking generally, it may be said that the greatest forward motion occurs near the surface, and the least near the depth of the keel; the actual variations in speed at different depths must be very different in different ships. Professor Reynolds, remarking on this circumstance, pointed out the fact that the upper blades of a single-screw must do the larger share of the propulsion, and that it was possible for the lower blades to be doing little work, or even hindering the action of the upper blades. Shocks and vibration may also result from the rapid revolution of the blades through layers of the wake having such unequal forward motions. Accepting these conclusions as fairly indicative of existing conditions, it will be obvious that single-screws are less favourably situated than twin-screws, not being so well immersed, nor so clear of the body of the ship, while they are of greater diameter and consequently sweep through layers of the wake, for which the inequality of forward motion is greater. The question of the deeper immersion of the screws deserves separate consideration; as it constitutes a marked advantage for twin-screws in smooth water steaming, and still more at sea. All that can be said, however, is that the effective thrust of a screw has been shown experimentally to be greatly reduced when it is near the surface.* Common

* See Professor Reynolds' experiments recorded in the *Transactions of the Institution of Naval Architects for 1874.*

experience confirms these experiments and shows that a partial emersion of a screw results in serious diminution of thrust, frequently accompanied by racing of the engines unless they are fitted with "governors."

These remarks on the comparative efficiency of single and twin screws have been carried to some length, because of their important bearing upon the future of steam navigation. The constant additions which are being made to the sizes and speeds of ships make it necessary to use greater and greater powers; and the question arises whether it is desirable to put all this power upon a single shaft and a single screw, or to duplicate the machinery and the propellers. The risks run through accidents to the shafts or propellers of single-screw steamers receive too frequent illustration in practice to need comment here; and the proportionate decrease in sail-power, now generally accepted in the larger steamships, makes the consequences of disablement of the propelling apparatus more serious than they were formerly. Even if it could be shown that twin-screws were less efficient propellers than single-screws, their advantages in other respects would recommend them for adoption at least in the larger classes of ocean-going merchant steamers. There is far less risk of total disablement of the propelling apparatus, and with either screw at work a twin-screw ship is not merely under control, but able to make good headway. Twin-screws give greater handiness to a ship, and enable her to be manoeuvred in case of serious damage to the rudder or steering gear. The duplication of engines and propellers also enables the watertight subdivision of the engine-rooms to be increased, as explained on page 26. Against these undoubted advantages are to be set the following considerations:—That twin-screws would be more liable to damage than single-screws when ships are going into or out of docks, coming alongside wharves, or taking the ground. That more space might be required for the machinery and shaft-passages, and a larger engine-room staff found necessary because of the duplication of the machinery; while the weight and-cost of the twin-screw engines might be greater than those for single-screw engines. Of these considerations the only one which seems to have much weight is that relating to possible damage to the propellers in harbour; but this risk may be lessened by the use of some kind of "guard" fitted over the screws, and will scarcely be thought to outweigh the undoubted advantages of twin-screws. Already a number of

twin-screw merchant steamers have been built, and it is probable that their employment will be extended, as many shipowners, shipbuilders, and engineers have expressed their approval of this system of propulsion. In the Royal Navy all recent ships of large size or high speed have been fitted with twin-screws: and this practice has been imitated in all the principal foreign navies. The gains in manœuvring power, watertight subdivision, and security against disablement have been the primary motives for the adoption of twin-screws in war-ships: but experience with those vessels has shown that in addition to these advantages twin-screws compare favourably with single-screws in their efficiency as propellers.

The details in support of this statement cannot be given here, but they are already published,* and include a careful comparison of the trials of a considerable number of single and twin-screw ships. As a rough indication of the results, although not an accurate comparison of efficiency, it may be stated that the ratio of indicated horse-power to wetted surface, was found to be 11 per cent. in favour of one group of twin-screw ships as compared with a group of single-screw ships of approximately similar form and equal size. For two other groups the advantage of the twin-screw ships rose to 18 per cent.; the sizes and speeds of the ships being greater. It cannot be asserted as yet that equal advantages would certainly be obtained in merchant steamers, which have greater lengths and fineness of form, and consequently experience less resistance than war-ships of equal displacements at high speeds. But the very satisfactory results attained in war-ships may encourage private shipowners to make trials of twin-screws, with the hope that, at least, no loss of efficiency will be involved as compared with single-screws.

From the brief sketch which has been given of the present state of the theory of the screw-propeller it will be evident that we are yet largely dependent upon experiment and experience for the selection of suitable forms and proportions of screw-propellers. There have been numberless patents, proposals, and trials of screws during the last forty-five years,

* See a Paper contributed by the Author to vol. xix. of the *Transactions* of Institution of Naval Architects. An interesting summary of facts as to the

performances of the earlier twin-screw vessels, built by Messrs. Dudgeon, will be found in vol. vi. of the *Transactions*.

and no settlement has yet been reached. Not a few of these proposals have been chimerical; and many of the experimental trials have been made under conditions which prevent any satisfactory analysis of the results. On the other hand, some of the trials have furnished valuable information which has subsequently been applied in practice.* Still it remains true that in any case lying outside the region of precedent and experience the selection of the most suitable propeller—including in that determination the diameter, pitch, form, and area of blades, &c., of the screw or screws—is a matter for experiment. And it is also true that the choice of the

FIG. 126 a

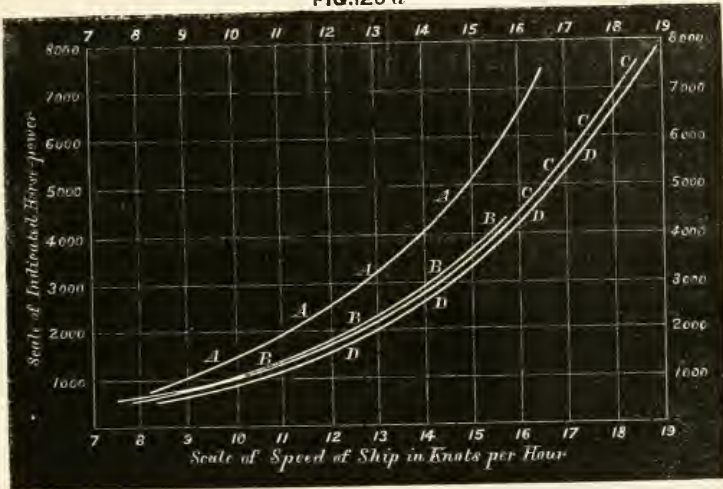

propeller exercises frequently a very marked effect upon the expenditure of power required to attain a given speed. Many illustrations might be given of these statements, but only one or two can be selected.

The case of H.M.S. *Iris* is one of the most recent and remarkable. When first tried on the measured mile she had four-bladed screws of 18 feet 6½ inches diameter, with a mean pitch of 18 feet 2 inches, and a blade-area of 194 square feet. The powers corresponding to various speeds were determined, and this information was used for the construction of the curve of indicated horse-power AAA in Fig. 126a. In that diagram, abscissæ measurements represent speeds in knots, and

* For an excellent summary of facts bearing on this subject, see Mr. Bourne's *Treatise on the Screw Propeller*.

ordinates represent the indicated horse-powers corresponding to the several speeds. The results of this series of trials were very disappointing, and it was decided to remove two of the four blades from each screw, leaving all other conditions unchanged. With this reduction in blade-area the curve of indicated horse-power, determined from another series of trials, fell to BBB, Fig. 126a. The highest power developed was 4369 horse-power, and the corresponding speed was $15\frac{3}{4}$ knots, whereas in the first series of trials 6200 horse-power was required for $15\frac{3}{4}$ knots, and 4369 horse-power corresponded to only $14\frac{1}{2}$ knots. These remarkable results led to fresh trials. The third series of trials was made with four-bladed screws, 16 feet $3\frac{1}{2}$ inches in diameter, 19 feet $11\frac{1}{2}$ inches pitch, with a blade-area of 144 square feet; and the results are graphically recorded by the curve CCC in Fig. 126a. The performance will be seen to agree very closely with that of the preceding series of trials. Lastly the vessel was fitted with two-bladed screws, 18 feet $1\frac{1}{2}$ inches in diameter, 21 feet $3\frac{1}{4}$ inches pitch, and having a blade-area of 112 square feet. The trials made with these propellers are recorded in the curve DDD, and the performance will be seen to be rather better than that of either the second or the third series. Considerable vibration took place, however, with these screws at certain speeds, although there was no troublesome vibration at the full speed of 18.6 knots; and it was decided to accept the four-bladed screws of the third series as the working propellers. A most thorough analysis of these trials has been made by Mr. Wright, Engineer-in-Chief to the Royal Navy; but there are many matters in the comparative performances of these screws which have, as yet, not received satisfactory explanation.* The broad fact remains, however, that with nearly the same indicated horse-power, and with practically the same number of revolutions of the engines per minute, a change in the screws enabled the speed to be increased from $16\frac{1}{2}$ knots to $18\frac{1}{2}$ knots per hour. Or, to state the case somewhat differently, whereas on the first trial a speed of $16\frac{1}{2}$ knots required 7500 horse-power and 91 revolutions, on the third series of trials an equal speed was attained with 5100 horse-power and 85 revolutions.

Another illustration of the influence which the choice of

* For a full account of these trials, and an analysis thereof, see Mr. Wright's

Paper in the *Transactions* of the Institution of Naval Architects for 1879.

a suitable propeller may have upon the performance of a steamer, may be taken from information placed at the disposal of the Author by Mr. Yarrow. It was desired to determine the best form of propeller for a torpedo-boat of high speed, and a long series of trials was undertaken, no less than twenty-five different screws being tried progressively, so that curves of indicated horse-power could be drawn for each. From these trials we have selected two extreme cases, and recorded the results in Fig. 126*b*. The curve AAA in that diagram records the ascertained performance of a two-bladed screw of 5 feet 6 inches diameter, 4 feet 6 inches pitch, having a blade-area of 496 square inches—with 560 horse-power indicated this

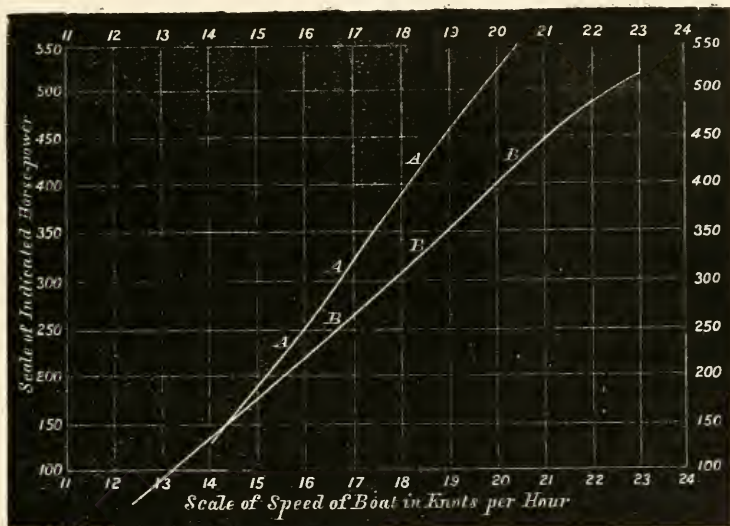
FIG 126*b*.

screw drove the boat $20\frac{1}{2}$ knots per hour. The curve BBB belongs to a two-bladed screw 4 feet 4 inches diameter, 5 feet pitch, and 540 square inches of blade-area—with 520 horse-power indicated this screw drove the boat at the remarkable speed of 23 knots per hour, $20\frac{1}{2}$ knots being attained with 430 horse-power. Some doubt attaches to the accuracy of the determination of the indicated horse-power in torpedo-boats, but the comparative expenditure of power with these two screws is not likely to be affected by any such inaccuracy, and the influence of the propeller is even more marked than in the case of the *Iris*.

In order that trials of the kind now under consideration may be made to yield the fullest possible information they must embrace a determination of the tow-rope resistances of the vessel at various speeds, the corresponding thrusts of the propellers, the work done in overcoming the friction of the engines, shafting, and propellers, the slip of the screw, &c. Such an investigation requires the greatest care in observation, and involves a very large amount of labour, even when applied as it was by Mr. Isherwood to the steam-launch mentioned on page 551. For large ships, driven by engines of considerable power, the difficulty and laboriousness of the task would necessarily be much increased, and, as a matter of fact, we are not aware of any such investigation having been made. But by a judicious use of models, both for screws and ships, it may be found possible hereafter to avoid much of this labour, and to select the most suitable screws without the trouble and expense of experiments on a large scale. Much valuable information affecting the performances of large ships may also be obtained from observations made on the propulsion of small vessels or steam-boats; and in this respect the performances of the fast torpedo-boats recently constructed furnish a great field for study. It is impossible to dwell upon this subject here, but one very interesting experiment recently made by Mr. Thornycroft must be mentioned. The torpedo-boat *Lightning* of the Royal Navy was originally fitted with a screw-propeller 5 feet 6 inches in diameter; this was removed and a novel arrangement devised by Mr. Thornycroft was substituted. The screw-propeller is formed with a very large boss, and is of very small diameter. It is placed within a tube only 3 feet in diameter, and abaft it is fixed an arrangement of "guide-blades" into which the water from the screw is delivered. These blades are so shaped that the fluid pressure on them has a forward component, constituting a thrust which assists that on the propeller in propelling the vessel. Mr. Thornycroft states as the result of experiments that the effect of the guide-blades was about one-fifth of the whole propelling effect; and it is understood that the aggregate performance of the vessel with the new propeller was equal, if not superior, to that with the original propeller of nearly twice the diameter. It need scarcely be remarked that, if similar apparatus can be applied on a large scale, enormous engine-powers may be efficiently utilised on draughts of water not exceeding those

at present accepted for the larger classes of ships.* In this way one of the difficulties incidental to the attainment of much higher speeds than have yet been reached may be overcome.

Notwithstanding the drawbacks to its efficiency which have been mentioned above, and the want of accurate knowledge respecting many features of its performance, the screw has quite superseded the paddle for ocean navigation and deep-water service; has been proved equal, if not superior, to the paddle on smooth water trials of speed, and has surpassed the jet on the only occasions when fair comparative trials have been made. Provided that the draught of water of a ship is great enough to permit the use of a screw or twin-screws of sufficiently large diameter, they are generally preferable to paddles. When the draught is too limited even for twin-screws, paddles are usually preferred to multiple-screws, the latter being used only in special cases as explained on page 549. It has been questioned whether in smooth water the screw is so effective as the paddle; but the early trials made between the *Rattler* and *Alecto*, as well as those between the *Niger* and *Basilisk*, indicated a decided superiority in the screw, and this opinion has been confirmed by a careful comparison of the measured mile performances of paddle and screw steamers of similar types. The chief cause of the greater efficiency of the screw, as ordinarily applied, must be found in the relatively large quantities of water upon which it operates in a unit of time, as compared with the quantities dealt with by paddles or jets. This advantage compensates, or more than compensates, for the disadvantage attending the obliquity of action, frictional resistance and considerable augment of resistance which accompany screw propulsion.

Smooth-water performances are not the true test of efficiency; in a seaway the screw is far more superior to the paddle than it is on the measured mile. Rolling motions, which would seriously affect the paddle, leave the screw almost uninfluenced. Pitching oscillations of course affect the screw more than the paddle; but if the screw is well immersed, or, still better, if twin screws are employed, the loss of efficiency on account of pitching does not appear to be at all serious in large ships. Considerable varia-

* Mr. Thornycroft's invention will be found described in the specification of his Patent.

tions in the draught of water may also take place, yet leave the screw efficient; whereas it has been shown that this is not equally true of the paddle. The screw lends itself much more readily than the paddle to the association of steam with sail power; the absence of projecting paddle-boxes is a great advantage in steaming head to wind and in general service; and, finally, in warships the screw is much less exposed to damage in action. The most convincing argument in favour of the superiority of the screw under all conditions of service is, however, to be found in the fact that it has almost entirely replaced the paddle in sea-going ships of the mercantile marine, wherein economical propulsion is of the highest importance.

Estimates for the Horse-Power and Speed of Steamships.

Attention will next be directed to the methods by which, in designing a new steamship, an approximation is made to the indicated horse-power required to propel her at a given speed. A few preliminary explanations will be necessary, in addition to those given on page 519, as to the meaning of the term "indicated horse-power."

When an engine is in motion under its load, a considerable part of the indicated horse-power must be expended in overcoming frictional and other resistances, working the air-pumps, &c., and only the remaining part of the power is available to give motion to the propeller. The frictional resistance may be divided into two parts, viz. the *initial* or *constant friction*—due to the dead weight of the moving parts, the tightness of piston-packings, shaft-bearings, &c.—which is probably the same for all speeds; and, second, the friction due to the "working load" on the engines, which varies with the speed and thrust. General experience appears to indicate that the ratio of the available power to the total indicated power, when well-designed marine engines are working at full speed, varies from 70 to 80 per cent.; and this ratio expresses the *efficiency of the mechanism*. Hitherto the determination of this ratio, by direct experiment, has been made in very few cases. The late Mr. Froude devised a method by which the "constant friction" of the engines might be inferred from the results of a series of trials made at different speeds; and this method has since been extensively used, but the results are not of so certain a character as to command com-

plete confidence.* So far as his investigations extended, Mr. Froude estimated that in the engines of screw steamers working at full speed, the constant friction amounted to one-eighth or one-sixth of the gross load on the engine; one-seventh being a fair average value. In the *Iris* the corresponding value for the constant friction was found to be about *one-twelfth*; and of this about 70 per cent. was proved by direct experiment to belong to the resistance of the engines, the remainder being due to the friction of the shaft-bearings. The results obtained from the progressive trials of a large number of merchant ships, have shown the constant friction, by Mr. Froude's method, to vary from 5 to 15 per cent. of the gross load at full power, in some cases being even lower. Mr. Isherwood, in the trials of the steam launch above mentioned, found, by experiment, that the constant friction of the engines was rather under 3 per cent. of the gross load at full power. Although it is an undoubted fact that the proportion of the constant friction to the gross load may vary considerably in different types of engines, yet the great variations in its relative value instanced above, for engines of very similar type, show that the analysis from progressive trials cannot be implicitly trusted. The explanation is probably to be found in the great difficulty of obtaining exactly accurate results at extremely low speeds on these trials. Hence it is the opinion of all authorities on the subject that some dynamometric apparatus should be used to determine the power actually delivered to the screw-propeller by marine engines when working at different speeds. One of the last pieces of work performed by the late Mr. Froude for the Admiralty consisted of the construction of such a dynamometer, entirely novel in its character, and probably well adapted for its purpose.† The instrument was not completed until after his death, and the trials made with it up to the present time have been only preliminary. But these trials are to be continued, and from them much useful information may be hoped for, not merely as to the values of initial friction, but the "friction of the load." As to

* For Mr. Froude's method see *Transactions* of the Institution of Naval Architects for 1876. The Author is indebted to Mr. W. Denny and Mr. John Inglis, junior, for much valuable data as to constant friction deduced

from the analyses of progressive trials.

† For a description of the Dynamometer see the *Proceedings* of the Institution of Mechanical Engineers for 1877.

the latter there is little exact information available for marine engines. For land engines the friction of the load is usually assumed to be about $14\frac{1}{3}$ per cent. of the useful load; Mr. Froude adopted nearly the same figure as a fair value for marine engines; Mr. Isherwood gives $7\frac{1}{2}$ per cent. for the engines of the steam launch.

In passing, it may be desirable to draw attention to the very important influence which the "constant friction" may have upon the expenditure of power, at speeds which are moderate or low in proportion to the speed at full power. This is a matter of the greatest interest in war-ships which usually cruise at very moderate speeds, although their engines are adapted for possible propulsion at much higher speeds. As an illustration we will take the case of the *Iris*, which has engines capable of developing about 7500 horse-power, and driving her 18 knots per hour, but which can be driven at 9 knots with about 800 horse-power. It was stated above that at full speed the horse-power expended in overcoming constant friction was only 8 per cent. of the gross indicated horse-power. At 9 knots, however, the constant friction would be absorbing no less than 30 per cent. of the gross indicated horse-power; and at 6 knots about 50 per cent., if both sets of engines were kept at work. Hence it will be obvious that at these moderate speeds it would be economical to stop one set of engines entirely, and keep the ship straight by using a little helm—a conclusion which is quite borne out by experience with the ship. The possibility of effecting this economy is another advantage of the duplication of engines in the twin-screw system. Moreover, it will be clear that in war-ships of large size and very high speeds, the still further subdivision of the machinery, say into four sets of engines instead of two, must be advantageous so far as economy of power under the ordinary conditions of service are concerned.

Passing from the engines to the propellers of steamships, still further "waste" of the gross indicated horse-power occurs. In jet-propellers there is the friction of the water in the passages through which it is delivered; with paddles there is the friction and "churning" of water by the floats; with screws there is the frictional and edgways resistance of the blades. The greatest interest naturally attaches to the last-mentioned source of waste; and we are fortunate to have some trustworthy experimental *data*. In the towing experiments made with the *Greyhound* (see page 462) it was found that when the two-bladed screw revolved freely, as the ship moved ahead at 10 knots, the additional resistance amounted to about 11 per cent. of the nett resistance without the

screw. In similar experiments made by Mr. Isherwood with a steam launch, the corresponding increase in resistance produced by the free revolution of different screws varied from $8\frac{1}{2}$ to 21 per cent. of the nett resistance of the vessel, the higher values occurring in the screws with the larger number of blades and larger blade-area. In both these cases the rate of revolution of the screws was considerably less than that at which they would have been driven if they had propelled the vessels at the speeds at which the towing experiments were made; so that the waste-work on the screws in propelling would have exceeded that indicated by the experiments. For the *Iris* detailed calculations were made, with the best *data* available for the probable screw friction, and the following were the results for full speed. With the original four-bladed screws at 91 revolutions, the *nett* horse-power on screw resistance was 1120 horse-power; with the working four-bladed screws now on the ship at 97 revolutions 420 horse-power; with the two-bladed experimental screws of the last series of trials 330 horse-power. (See page 558 for description of the screws.) It is difficult to convert this nett horse-power into indicated horse-power; but probably an increase of *one-third* will be within the truth. Assuming this ratio to hold, the waste-work of the first screws absorbed .20 per cent. of the maximum I.H.P. on the first trials; that of the working screws absorbed about 8 per cent. of the maximum horse-power on their trials; and that of the experimental two-bladed screws absorbed about 6 per cent. These figures, although approximations only, afford good evidence of the importance attaching to all possible reductions in the resistance of screws by using the least blade-area consistent with efficiency at sea as well as in smooth water; disposing that area in the form which will enable the necessary propelling effect to be produced with the least friction; keeping the surface of propellers clean and smooth, and so shaping the edges as to diminish edgeways or eddy-making resistance. It may be interesting to add here, although only indirectly connected with the foregoing remarks, that in high-speed torpedo-boats the use of thin screw-blades of great strength and elasticity has been found to favour improved performance.

Summing up these general considerations it appears that the ratio which the indicated horse-power bears to the "effective horse-power" of a steamship (defined on page 518) depends upon (1) the efficiency of the mechanism of the engines; (2) the efficiency of the propeller; (3) the augment of the nett resistance

of the hull produced by the action of the propeller (see page 550). It appears further that the present state of our information does not enable us to deal with each of these efficiencies separately; and so, to arrive at the exact value of the indicated horse-power required to drive a given ship at any assigned speed. Hence it happens that in estimates for the engine-power of a new ship it is customary to include all the above-named factors in one approximate solution; although the approximation may be made in any one of several methods.

The oldest method of approximation, and that still most generally employed, is to proceed by the comparison of a new ship with existing ships, making use of "coefficients of performance" based upon their trials. The ordinary forms of these coefficients are known as the "Admiralty coefficients," it having been the practice from a very early period in the construction of steamships for the Royal Navy to make careful trials of speed and to tabulate the information thus obtained for guidance in future practice. The Admiralty formulæ may be expressed very simply.* Let D = displacement of ship (in tons) at the draught of water on the trial; A = the corresponding area (in square feet) of the immersed midship section; V = speed (in knots) per hour; and P = indicated horse-power, then

$$C_1 \text{ (midship-section coefficient)} = \frac{A \times V^3}{P};$$

$$C_2 \text{ (displacement coefficient)} = \frac{D^{\frac{2}{3}} \times V^3}{P}.$$

In these expressions it is assumed—(1) that the resistance of the ship will vary as the *square* of the velocity, and the work to be done in propelling her as the *cube*; (2) that the useful or propelling effect of the engines, after allowing for the waste-work to be done in overcoming frictional resistances, &c., of the machinery, and the waste-work of the propeller, will vary as the indicated horse-power; (3) that for similar ships the resistances corresponding to any assigned speed will vary as the area of the immersed midship section, or the two-thirds power of the displacement. The character of the first and last assumptions, and the limits within which they may be applied, have already been made

* It may be interesting to state that the midship-section coefficient in their French naval architects generally use estimates for speed and power.

the subject of comment in the preceding chapter. It has been shown that, so long as the speeds attained do not exceed the limits where wave-making resistance becomes important in proportion to frictional resistance, the law of the total resistance varying as the square of the speed holds fairly. Beyond that limit the law of variation involves a higher power of the speed. The second assumption also appears to hold fairly well with engines of similar and good design, and with any selected propeller of good proportions. It cannot, however, be applied without correction when the propellers of the two ships compared are of dissimilar character—one, say, a paddle, and the other a screw; nor can it be applied to all types of engines, the waste-work being greater in some than in others. The greater the similarity in ship, engines, and propellers, the greater will be the degree of accuracy possible with this method of estimation.

With the foregoing limitations, the coefficients of performance furnish a good means of comparing the economy of propelling power in ships of similar form and proportions, and not very different sizes, as well as of estimating the probable power for a new ship. Of the two coefficients, that for the displacement is, on the whole, the more trustworthy, giving a fairer measure of the resistance than the midship-section coefficient, especially when dealing with ships which are not of exactly similar form.

As an example of the use of these coefficients, take the case of her Majesty's ship *Bellerophon*. On the measured mile, with a displacement of 7369 tons, a midship-sectional area of 1207 square feet, and an indicated power of 6312 horse-power, she attained a speed of 14·053 knots per hour.

$$C_1 = \frac{1207 \times (14\cdot053)^3}{6312} = 531 ;$$

$$C_2 = \frac{(7369)^{\frac{2}{3}} \times (14\cdot053^3)}{6312} = 166.$$

The ship is 300 feet long, 56 feet broad, and had a mean draught of water, on trial, of $24\frac{1}{4}$ feet; hence her

$$\text{Coefficient of fineness}^* = \frac{7639 \times 35}{300 \times 56 \times 24\frac{1}{4}} = 0\cdot63.$$

When her Majesty's ship *Hercules* was designed, if the performances of the *Bellerophon* had been known, the engine-power

* See page 4.

required might have been approximated to in the following manner—her length being 325 feet, breadth 59 feet, and mean draught $24\frac{2}{3}$ feet, her displacement was 8680 tons, and the area of midship section 1314 square feet. For these dimensions—

$$\text{Coefficient of fineness} = \frac{8680 \times 35}{325 \times 59 \times 24\frac{2}{3}} = 0.64,$$

or nearly the same as the fineness of the *Bellerophon*. It might have been assumed therefore that the *Hercules* would have coefficients of performance very nearly equal to those stated above. On trial the vessel attained 14.69 knots per hour; let this be taken as the designed speed, and let the corresponding horse-power be required. Using the midship-section coefficient 531,

$$\text{Probable I.H.P.} = \frac{1314 \times (14.69)^3}{531} = 7845 \text{ (nearly).}$$

Using the displacement coefficient 166,

$$\text{Probable I.H.P.} = \frac{(8680)^{\frac{2}{3}} \times (14.69)^3}{166} = 8065 \text{ (nearly).}$$

The actual indicated power required to drive the *Hercules* at the speed of 14.69 knots was rather more than 8520 horse-power, or about 6 per cent. above the approximation from the displacement coefficient, and about 9 per cent. above that from the midship-section coefficient. These results bear out what was said above as to the displacement coefficient being on the whole the more trustworthy; and they are sufficiently close to the truth for practical purposes. It may be explained, however, that the variation of the resistance at these high speeds for ships of this type depends upon some higher power of the speed than the square; and the naval architect would allow for this in his estimate, increasing the power somewhat above that given by the foregoing approximate method. In making this increase, he would be guided by the recorded performances of the exemplarship at some less speed than the full speed; nearly all the vessels of the Royal Navy having been tried at reduced-boiler power as well as full power. For example, the *Bellerophon*, steaming at a speed of 12.15 knots, had a midship-section coefficient of 543 and a displacement coefficient of 171, as against 531 and 166 for a speed of 14.05 knots, indicating that the power required to drive the ship varied with a higher power than the cube of the speed. It really varied between those speeds as $V^{3.3}$; and if this

correction is made for the *Hercules* in the preceding calculation, the probable indicated horse-power will rise to 8300, or within 2½ per cent. of the power actually developed. To ensure the attainment of the speed desired, the naval architect would almost certainly provide some margin of indicated horse-power above that to which the approximate method conducts.

The difficult part of the work in practice lies in the selection from available data of exemplar-ships most nearly resembling the new design, in order that the appropriate coefficients may be obtained. In making this selection, it is necessary to compare carefully the fineness of form, the dimensions, the lengths of entrance and run in proportion to the maximum speeds, and some other particulars of the new ship and the completed ships; and to make allowances for greater or less fineness of form, differences in the frictional resistance, or any other matter affecting the speed under steam. In the Royal Navy, for the greater number of classes, little difficulty is experienced in discovering suitable examples; but when entirely new conditions are introduced, it is not possible to proceed with equal certainty, and then it becomes necessary, in proceeding by this comparative method, to allow a considerable margin of power and speed.

Take, for example, the *Devastation*, a vessel of very full form, moderate proportions of length to beam, and one of the earliest deep-draught twin-screw ships. It was estimated in designing this ship that with 5600 horse-power and a displacement of 9060 tons, a speed of at least 12½ knots would be obtained; this would give a displacement coefficient

$$C_2 = \frac{(9060)^{\frac{2}{3}} \times (12\frac{1}{2})^3}{5600} = 151.$$

On the measured mile, with a displacement of 9190 tons, the ship steamed 11·91 knots with 3400 horse-power, the displacement coefficient being 218; and at full speed she realised 13·84 knots with 6650 horse-power, the corresponding coefficient being 175. Had only the estimated power—5600 horse-power—been realised, the vessel would have steamed about 13 knots, that is, about ½ knot faster than the estimated speed. Or, had she steamed 12½ knots, the indicated horse-power required would have been only 4000 horse-power, instead of 5600 horse-power, as estimated.

When the *Devastation* had been tried, and her coefficients determined, it was an easy matter to determine the appropriate

engine-power for the succeeding deep-draught ships with twin-screws; and the superior performances of twin as compared with single-screws rendered it possible to economise engine-power. This was done; and in the *Alexandra*, *Temeraire*, and other vessels, the engines were made less powerful and weighty than they would have been with single-screws. Subsequent trials have fully justified this procedure. Take, for example, the *Alexandra*. It was estimated that 8000 horse-power would suffice to drive the ship about 14 or $14\frac{1}{2}$ knots, when fully laden and weighing 9500 tons. On the measured mile the speed of 15 knots was attained, and the engines exerted 8600 horse-power, 600 horse-power more than the guaranteed power. When allowance is made for this excess of power, it appears from calculation that the fully-laden ship would have exceeded the upper limit of her intended speed with 8000 horse-power. Had she been fitted with a single-screw, instead of twin-screws, in all probability at least 500 or 600 horse-power additional would have been required to attain the same speed.

Another method of approximation which has been largely used consists in the determination of the ratio of the indicated horse-power to the wetted surface in the exemplar-ship or ships at the trial speeds; and the estimate from this ratio of the probable value of the corresponding ratio for the new ship at her designed speed. This method of procedure will be seen to correspond to that described for sailing ships on page 495. It can be safely used when the speeds considered are moderate in proportion to the dimensions; for which speeds the resistance of the new ship, as well as those of the exemplar-ships, vary nearly as the square of the speeds. From the remarks made on the surface friction of ship-shaped forms on page 448, it will appear that larger differences of form, within the stated limits of speed, can probably be dealt with by this method, than by the use of the "Admiralty coefficients," and more particularly than by the use of the midship-section coefficient. Beyond the limits of speed where wave-making resistance assumes relative importance, neither the wetted surface ratio nor the Admiralty coefficients can be applied without correction of the kind indicated above.

The late Professor Rankine proposed a method for computing the probable speed and power of steamships closely resembling that just described. Assuming that the speeds were kept within the limits for which the resistance varied sensibly as the square of the speed, Rankine approximated to the resistance by means

of the "augmented surface" described on page 447. The nett resistance of the hull in well-formed ships with clean bottoms he thought might be expressed in the form—

$$\text{Nett resistance (in pounds)} = \frac{\text{Augmented surface (in square feet)} \times \text{Speed of ship (in knots)}^2}{100}.$$

The ratio of the "Effective Horse-Power" (estimated from the nett resistance) to the Indicated Horse-Power, he assumed to be 1 : 1.63; and thence obtained as a final approximate rule for practice:—

$$\text{Probable I.H.P.} = \frac{\text{Augmented surface} \times (\text{speed in knots})^3}{20,000}$$

This divisor was termed the "coefficient of propulsion," and its value might vary considerably in different ships with differences in the roughness of the bottom, the efficiency of the engines and propellers, or defects of form. In some cases it was found to be as low as 16,000. The remarks made above as to the use of the wetted surface apply here also. Either method, depending as it does upon the assumption that the resistance varies as the square of the speed, fails to include a very large number of the cases occurring in practice; and Rankine's coefficient of propulsion, like the Admiralty coefficients, rarely has a constant value for a large range of speed in the same ship. Moreover, on the basis of the experiments made by Mr. Froude, it may be questioned whether the computation of the augmented surface is to be preferred to that of the wetted surface, even for estimates of surface friction. As a provisional theory, this of Rankine's was valuable; but subsequent experiments with ships and models have practically superseded it.

Attention must next be directed to the very valuable assistance in speed-calculations derivable from *progressive steam-trials*; that is to say, the trial of the same ship at several different speeds, and the determination of the horse-power, and other particulars for each speed. Trials of this kind have been made occasionally with ships of the Royal Navy for a long time past, but the system has not been generally adopted. Formerly the measured mile trials were made with full and half boiler-power; the regulations now in force provide for trials at full, two-thirds, and one-third boiler-power. In subsequent service the expenditure of power and coal at still lower speeds are ascertained in deciding on the most economical rate of steaming. As early examples of

more extended trials, made for special purposes, we may refer to the trials made with the *Flying Fish* in 1856, to test different kinds of propellers and forms of bow; those made on Her Majesty's yacht *Victoria and Albert* in 1855-56; and those made on the *Warrior* in 1861. In the case of the *Victoria and Albert*, the trials were very exhaustive, and the curve of horse-power corresponding to various speeds (see Fig. 126*d*, page 586) was constructed similarly to those previously given for the *Iris*. Outside the Royal Navy also such trials were occasionally made. Mr. Isherwood, in 1869, tried the steam launch, to which so many references have been made, progressively; and determined the

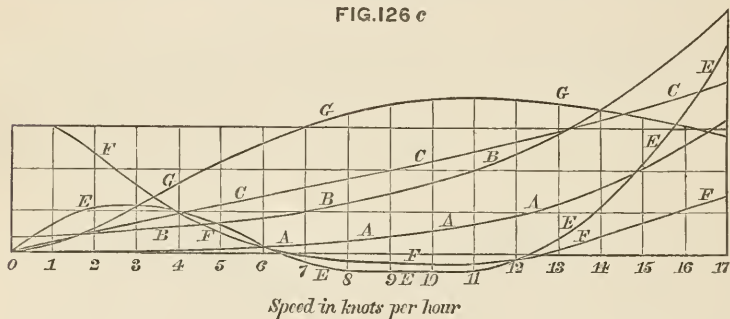
FIG. 126 *c*

References.

- A A A — Curve of indicated horse-power.
 B B B — " " " thrust.
 C C C — " " revolutions of screw.
 E E E — " " slip of screw (apparent).
 F F F — " " slip of screw, expressed as percentage of
 its speed.
 G G G — " " coefficients of performance.

power, revolutions and slip of screw, mean-pressure, &c., for a large number of speeds, in order that he might construct curves for all these features of the performance. Mr. Thornycroft did very similar work for some of the small swift vessels built by him.* All these progressive trials were, however, exceptional, and it is only within the last ten years that their conduct has become frequent in the mercantile marine, although their value is now widely recognised. This change of practice and development of progressive trials is chiefly to be attributed to the action of Mr. W. Denny (of Dumbarton), whose firm took the lead in

* See *Transactions* of the Institution of Naval Architects for 1869 and 1872.

this movement, and greatly assisted its progress by the publication of a large amount of valuable information obtained on the trials of ships built by them.* At the present time progressive trials are commonly made with new ships by the principal ship-builders on the Clyde, and are growing in favour with ship-builders generally. An example of the ordinary method of recording these trials is given in Fig. 126*e*, and represents the performance of a very successful steamer built by Messrs. A. & J. Inglis, of Glasgow. Abscissæ measurements on the base-line represent speeds in knots per hour. The curve A A A represents, by its ordinate measurements, the variation of the indicated horse-power with the speed; it was drawn through points determined by trials made at a series of four or five speeds between 8 knots and 15½ knots. The curve B B B represents, by its ordinates, the variation of the "indicated thrust" with variations of the speed. This curve is obtained from the curve A A A taken in connection with the curve C C C, which represents, by its ordinates, the variation of the revolutions of the screw with the speed, these revolutions being counted for each trial speed, and the curve C C C being drawn through the points thus obtained. Since the indicated thrust equals the fraction

$$\frac{33,000 \times \text{I.H.P.}}{\text{Pitch of screw} \times \text{revolutions per minute}}$$

while the indicated horse-power is expressed by the product (see page 519),

$$\text{Mean piston pressure} \times \text{stroke} \times \text{revolutions,}$$

it is obvious that the curve B B B, by its ordinates, represents "mean piston pressure" for any speed as well as "indicated thrust," the scales being different in the two cases. At the zero of speed there is an ordinate value for the curve B B B; this represents the "constant friction" (see page 562). The curve E E E represents the apparent slip of the screw in knots, and F F F the percentage of slip; these are obtained from the curve C C C, the pitch of the screw being given. Another curve G G G also appears, its ordinates being proportional to the quotient of the cube of the speed by the indicated horse-power; it is derived from curve

* See Papers by Mr. W. Denny contributed to the *Proceedings* of the Institution of Engineers and Ship-

builders in Scotland for 1875; and to the British Association for the same year.

A A A. This curve G G G is termed the "curve of coefficients," and its ordinates can obviously be made to represent, by suitable scales, both the Admiralty coefficients and Rankine's coefficient of propulsion. Were these coefficients really "constants," the curve of coefficients would become a straight line parallel to the base-line.

With these graphic records of progressive trials before him, the designer of new ships of similar form and type can proceed with greater assurance of success than is attainable with less extensive information. If a ship of practically identical form and size, but less speed, is to be built, his task is simply one of measurement from the curves, with some slight correction for difference in constant friction. If the speed of such a ship is to be greater than that of her predecessor, it is also possible to make a close approximation—provided that the excess in speed is not very considerable—from an inspection of the curves of indicated horse-power and coefficients. When the sizes and speeds of ships are both varied, but approximately similar forms are maintained, the problem is more complicated, but still it can be dealt with approximately, by an application of Mr. Froude's law of "corresponding speeds" explained on page 471.*

Supposing that in the graphic record of the results obtained on a progressive trial, the constant friction of the engines be determined, and then eliminated from the indicated thrust by drawing a line parallel to the base-line through the point where the original curve of indicated thrust (B B B, Fig. 126c) cuts the ordinate of the zero speed. The line so drawn forms a new base-line, giving the indicated thrusts and mean piston pressures, excluding constant friction; and the corresponding corrected indicated horse-power curve can be constructed. In what follows we shall speak of these corrected curves, and of the derived curve of coefficients.

Next let it be assumed, although not strictly nor necessarily true, that the corrected indicated thrust bears a constant ratio to

* Mr. Froude indicated this application in a Paper on "Useful Displacement" contributed to the *Transactions* of the Institution of Naval Architects in 1874. The Author had also applied it commonly in his professional work for some time before the publication of the first edition of this book, and therein

gave an illustration of the method. Mr. John Inglis, junior, was led to the same practice by a study of Mr. Froude's writings, and contributed a valuable Paper on the subject to the *Transactions* of the Institution of Naval Architects in 1877.

the nett resistance at any speed. For any speed V_1 of a ship that has been tried, let T_1 = the corrected thrust (or mean pressure) and P_1 = the corresponding horse-power. Then, with the foregoing assumptions, if we increased the lineal dimensions of the ship D times, and towed the larger ship at a speed of $V_1 \sqrt{D}$, her resistance at that speed (or indicated thrust) would be expressible in the form

$$T_2 = T_1 \cdot D^3$$

and the corresponding horse-power would be

$$P_2 = T_2 \times V_1 \sqrt{D} \times \text{a constant,}$$

while $P_1 = T_1 \times V_1 \times \text{the same constant.}$

Hence

$$\frac{P_2}{P_1} = \frac{T_2}{T_1} \cdot \sqrt{D} = D^{\frac{7}{2}}$$

This is an expression from which the horse-power for the larger ship can be found for a speed $V_1 \sqrt{D}$, when that for the exemplar-ship has been ascertained from the progressive trials at speed V_1 . To the value of P_2 , thus determined, must be added the assigned percentage for constant friction, of which particulars are given on page 563, in order to find the indicated horse-power required for the speed ($V_1 \sqrt{D}$). In this manner not merely the power for full speed can be estimated approximately, but that for any other speed, and so a new curve of indicated horse-power can be drawn for the new ship. This could not be done, it will be seen, unless curves such as those in Fig. 126c were available; and they are therefore of great value. If the difference in size is considerable between the two ships, it may be necessary to deal with the frictional resistance separately, and to apply the foregoing rules to the wave-making resistance only; but this kind of correction is not usually made.

Using the same notation as before, another deduction may be made from the foregoing investigation. Suppose the coefficient of performance curve for the exemplar-vessel to be drawn from the equation

$$\text{Coefficient} = \frac{\text{Speed}^3 \times \text{Area of midship section}}{\text{Indicated Horse-power}}$$

Let A_1 = area of midship section in smaller vessel; A_2 = corresponding area in larger vessel; then obviously $A_2 = D^2 \cdot A_1$.

Also, the following values will hold good:—

$$C_1 = \text{Coefficient for smaller vessel at speed } V = \frac{V^3 \times A_1}{P_1};$$

$$C_2 = \text{Coefficient for larger vessel at speed } V\sqrt{D} = \frac{V^3 \times D^{\frac{3}{2}} \times A_2}{P_2};$$

$$\therefore \frac{C_1}{C_2} = \frac{A_1}{A_2} \cdot \frac{P_2}{P_1} \cdot \frac{1}{D^{\frac{3}{2}}} = \frac{A_1}{D^2 A_2} \times \frac{P_1 \cdot D^{\frac{7}{2}}}{P_2} = 1$$

That is to say, with the preceding assumptions, the coefficients of performance for two similar vessels steaming at “corresponding speeds” are identical. This statement holds good for both the Admiralty coefficients as well as for Rankine’s coefficient of propulsion. In practice it may be modified by some departure from the assumptions; but the broad deduction is useful for practical purposes in comparing efficiencies of vessels similar in form and method of propulsion, but unequal in size.

From this investigation it follows that for two ships of unequal size, but similar form and similarly propelled, driven at the *same speed*, the larger will have the higher coefficient of performance; the indicated horse-powers usually increasing at a more rapid rate than the cube of the speed.

In applying the results of progressive trials to speed calculations care is required, of course, to secure, if possible, similar conditions in the exemplar-ship and the new design as regards not merely form, but type of engine and propeller, and equal smoothness of bottom. Differences in the coefficient of friction, arising either from different degrees of roughness or greatly different lengths of ships (see page 436), must be allowed for; and this can be done without difficulty, if desired, in comparing small ships with large. In fact, to secure the closest approximation to the horse-power in a new ship, every part of the work requires to be done with scrupulous care and intelligence. For rough estimates, on the other hand, some of the foregoing corrections may be omitted; and more especially the correction for constant friction of engines when approximating to the indicated horse-power for full speeds.

One example only can be given of the approximate formulæ based on corresponding speeds. We will choose Her Majesty’s ships *Hercules* and *Greyhound*, which are very similar in form, but different in size, speed, and character of bottom.

The similarity of the forms will appear from comparing the ratios of the lengths, breadths, draughts, and cube-roots of the displacements given in the Table below. Using the letter D to express this ratio, we have,

$$D = \sqrt[3]{\frac{8676}{1157}} = 1.957;$$

$$\sqrt{D} = \sqrt{1.957} = 1.4 \text{ (nearly).}$$

On trial, the *Hercules* attained a speed of 14.69 knots.

$$\left. \begin{array}{l} \text{Corresponding speed} \\ \text{for } \textit{Greyhound} \end{array} \right\} = \frac{14.69}{\sqrt{D}} = \frac{14.69}{1.4} = 10.5 \text{ knots (nearly).}$$

On trial, the *Greyhound* attained a maximum speed of 10.04 knots with 786 indicated horse-power; at that speed her resistance was varying about as the *cube* of the velocity, and therefore the horse-power would vary as the fourth power. Hence

$$\left. \begin{array}{l} \text{Indicated horse-power for} \\ \text{speed of } 10.5 \text{ knots} \end{array} \right\} = 786 \times \left(\frac{10.5}{10.04}\right)^4 = 940 \text{ H.P.}$$

Ships.	Length.	Breadth.	Mean Draught.	Displacement on Trial.
	Feet.	Feet.	Feet.	Tons.
<i>Hercules</i> . .	325	59	24.6	8676
<i>Greyhound</i> .	172½	33½	13.7	1157

The thrust of the propeller in the *Greyhound* at 10.5 knots might therefore be considered proportional to the quotient $940 \div 10.5$; if for the *Hercules* at 14.69 knots a corresponding assumption is made, and the thrust considered to be proportional to the quotient of the required indicated horse-power (P, say) $\div 14.69$. In both ships the engines would be working at full speed; and for our present purpose it may be assumed that the thrusts would be proportioned to the resistances of the two ships. Using the law of comparison proposed by Mr. Froude,

$$\left. \begin{array}{l} \text{Resistance for } \textit{Hercules} \\ \text{at } 14.69 \text{ knots} \end{array} \right\} = (1.957)^3 \times \left\{ \begin{array}{l} \text{resistance for } \textit{Grey-} \\ \text{hound at } 10.5 \text{ knots} \end{array} \right.$$

$$= 7.5 \times \left\{ \begin{array}{l} \text{resistance for } \textit{Grey-} \\ \text{hound at } 10.5 \text{ knots.} \end{array} \right.$$

Hence, approximately,

$$\frac{\text{I.H.P. for } \textit{Hercules} \text{ at } 14.69 \text{ knots}}{14.69} = \frac{7.5 \times 940}{10.5};$$

$$\text{I.H.P. for } \textit{Hercules} \text{ at } 14.69 \text{ knots} = 9870 \text{ horse-power.}$$

This power is largely in excess of that actually developed in the *Hereules*, when she attained a speed of 14.69 knots: but it must be remembered that in the calculation the same coefficient of friction has been assumed for the *Hereules* as for the *Greyhound*; whereas the *Hereules* was tried with a cleanly coated iron bottom, and the *Greyhound* with a copper bottom somewhat deteriorated by age. A correction is therefore necessary, and it may be simply made.

It has been estimated that for a speed of 600 feet per minute the coefficient of friction for the bottom of the *Greyhound* was about 0.325 lb. per square foot of surface, as against 0.25 lb. for a cleanly painted iron bottom; and this difference would involve an increase of between *one-seventh* and *one-eighth* in the total resistance, and indicated horse-power for the speed of 10.5 knots. In other words, if the *Greyhound*, instead of being tried with her worn copper, had been tried with a cleanly coated iron bottom, like that of the *Hereules*, the speed of 10.5 knots would probably have been attained with about 830 horse-power, instead of 940 horse-power. Making this correction in the foregoing equation, we have, approximately,

$$\begin{aligned} \text{I.H.P. for } \textit{Hereules} \text{ at } 14.69 \text{ knots} &= \frac{7.5 \times 14.69 \times 830}{10.5} \\ &= 8715 \text{ horse-power.} \end{aligned}$$

This is a close approximation to the actual power (8529 horse-power) which was developed on the measured-mile trial of the *Hereules*; but the same degree of accuracy may not always be secured in estimates made in this manner.

When unprecedented speeds have to be attained, or novel types of ships constructed, the only available method of making a trustworthy estimate of the engine-power required is found in recourse to model experiments. By means of such experiments, as explained in Chapter XI., the resistance and effective horse-power for any assigned speed can be determined; but when this has been done there still remains the determination of the ratio of the effective to the indicated horse-power. Experiments with model propellers may assist in the solution, enabling an estimate to be made of the augment of resistance, and possibly of the waste-work done by the propeller itself. And, as to the waste-work of the machinery, facts are already recorded which may be of service (see page 562). In this way, step by step, the approximation can be carried forward with greater certainty than would

otherwise be possible. This power of dealing with novel questions in propulsion, shipbuilders owe entirely to the genius and energy of the late Mr. Froude; and examples of its advantages are being rapidly multiplied. Amongst the more recent may be mentioned the cases of the *Inflexible* in the Royal Navy, and the Imperial Russian yacht *Livadia*. The *Inflexible* was of entirely novel form and proportions, but the estimates of the engine-power required for her intended full speed have been closely verified by the measured-mile trials. The *Livadia* was a still greater departure from previous practice, and in her case, too, the method of model experiments proved successful. Dr. Tideman's trials on the tow-rope resistances of a model were supplemented by an interesting series of trials on a large-scale model propelled by its own screws; and such a supplement cannot fail to be of value in extreme cases.

Ordinarily, having ascertained the effective horse-power for a new ship from the model experiments, it is possible to approximate to the indicated horse-power from experience with other ships. Information as to this ratio is still of moderate amount, and needs extension; for it is clear that it may have a very wide range in different types of ships and various forms of propellers. For screw steamers the ratio has been determined in many cases by a comparison of model experiments with measured-mile trials. Writing in 1876, after a careful analysis of the experiments available, Mr. Froude fixed from 37 to 40 per cent. of the indicated horse-power as a fair value for the effective horse-power in single-screw ships when steaming at full speed. Subsequent trials have given much higher percentages, reaching to 50 or even 60 per cent. in some single-screw ships of fine forms and unusually good performance. In some of the comparatively full-formed twin-screw ships of the Royal Navy the corresponding percentage has reached 45 to 50, and for the finer forms it has attained about the same values as for some of the most successful single-screw ships. In torpedo-boats and vessels driven at extraordinarily high speeds a still higher ratio of effective to indicated horse-power has been attained, according to the comparison of the model experiments with measured-mile trials; but in these extreme cases two difficulties present themselves. First: the calculation of the indicated horse-power is open to some question, no matter what care may have been taken; and second, in passing from the model to the full-sized boat the skin-friction correction cannot be made with certainty. Further experiments are needed therefore, and will probably be made, as the results will have a wide interest and range of application.

Limits of space prevent any further consideration of this important branch of ship construction, although we have by no means exhausted the subject, or even mentioned some interesting proposals relating to speed calculations; for these we can only refer readers to the original papers.*

Steamship Efficiency.

The subject of steamship efficiency has occupied much attention, and several standards of comparison have been proposed. None of these standards can be employed universally, however, in the comparison of different types of ships; because (as was remarked on page 461), in many types, and more especially in ships of war, the choice of forms and proportions is largely influenced by other considerations than those relating to *economical propulsion*. It is unnecessary to repeat the remarks already made on this point, although their importance is frequently overlooked; no distinction being made between the ideal conditions of forms of least resistance, propellers of maximum efficiency, and engines of perfect construction, and the conditions of practice with all their limitations or restrictions. Bearing this distinction in mind, we now proceed to summarise the circumstances which chiefly influence economy of steam-power.

First, and most influential, is the adoption of forms and proportions which lead to *diminished resistance*. Examples of the remarkable effects produced by increasing the length, and the fineness of form, were given in Chapter XI. To these may now be added a few others, as the subject possesses considerable interest. Some of the first-class Transatlantic mail steamers are about equal in weight and load-draught to the largest ironclad frigates of the Royal Navy; and the measured-mile speeds of the two classes are not very different, being from 14 to 15 knots. In the mail steamers the length is from 9 to 11 times the beam; in the earlier ironclad frigates, such as the *Warrior* and *Minotaur*, it is from $6\frac{1}{2}$ to $6\frac{3}{4}$ times; in the later ironclad frigates, such as the *Hercules* and *Alexandra*, from 5 to $5\frac{1}{2}$ times. For our present purpose it will be sufficient to compare the indicated horse-power

* See Mr. Kirk's Paper in the *Transactions* of the Institution of Naval Architects for 1880: various Papers by Mr. R. Mansell in the *Pro-*

ceedings of the Institution of Engineers and Shipbuilders in Scotland; the Reports of the British Association Committee on Steamship Performance, &c.

with the total weights driven; if this mode be followed, the vessels compare as under:—

	H.P.	
Transatlantic steamer	0·5	per ton of displacement;
Earlier ironclad frigates	0·6 to 0·7	” ” ”
Later ” ”	0·9 to 1	” ” ”

These are *average* values for the different classes; and they illustrate the considerably increased expenditure of power rendered necessary in the recent ironclads by reason of their moderate length and proportions.

To compare only the performances under steam of these various classes, and not to have regard to their contrasts in other respects, would be very misleading. The merchant steamer is built for remunerative service in carrying cargo and passengers; handiness, or quick turning, is of minor importance. In a modern war-ship, on the contrary, the provision of a necessary amount of stability and protection limits the choice of proportions (see page 461); while handiness is of the utmost importance, and to secure this quality, moderate length is needed. Adopting the moderate length, and being limited in draught, the displacement required has been obtained by greater beam and fulness of form, which cause greater resistance. But the price paid for increased manœuvring power under steam might not be too high, even if it were wholly additional to the cost of the long ship. In ironclad ships, however, this is not the case; but reckoning the total cost of hull and engines, the shorter type of ship can be made smaller and cheaper than a ship of the longer type fulfilling the same conditions as to speed, armour, armament, and coal endurance.

This question was very exhaustively discussed by Sir Edward Reed when Chief Constructor of the Navy, in order to justify his policy in passing from the *Warrior* and *Minotaur* types to the moderate proportions of the *Bellerophon* and *Hercules*.* From many illustrative cases, we will select one which seems to have peculiar interest. Taking the ironclad frigate *Hercules*, of which all the particulars and performances were known, an estimate was made of the dimensions and cost of a vessel which should have the same battery and guns, the same armour protection on the water-line belt, the same speed and coal supply, and which should be constructed on the same system as the *Hercules*; the

* See a Paper contributed to the *Transactions* of the Royal Society in 1868, and chap. ix. of *Our Ironclad Ships*.

proportion of length to breadth and the coefficients of performance under steam were, however, to be identical with those for the *Minotaur*. The following tabular statement shows the result of careful calculations:—

Particulars.	New Ship (as estimated).	<i>Hercules</i> .
Length (in feet)	385	325
Breadth (in feet)	57 $\frac{1}{6}$	59
Displacement (tons)	9088	8676
Weight (in tons) of—		
Hull	4574	4022
Armour and backing on belt	1518	1292
" " " on batteries	398	398
Engines, boilers, and coals	1460	1826
Equipment and armament	1138	1138
Indicated horse-power for speed of 14·69 knots	6585	8529
First cost of—	£	£
Hull	326,500	287,400
Engines } at average prices for ironclads } built prior to 1869.	55,500	72,000

After crediting the long ship with less powerful and costly engines, it appears, therefore, that the total cost of the *Hercules* for hull and engines would be about £22,000 less. The more powerful engines of the *Hercules* would undoubtedly be more expensive to keep at work, owing to their greater consumption of fuel; but "the interest at a low rate on the difference of prime cost would quite make up for the additional cost of fuel in the *Hercules*, supposing her to be in commission and on general service." The longer and larger ship, moreover, would be more costly to man and maintain in repair; but her most serious drawback would be her slow rate of turning as compared with the *Hercules*. On her trials at the measured mile the *Hercules* turned a complete circle in 4 minutes, the diameter being about 560 yards, or rather more than five times her own length. What the corresponding figures for the new ship would be with equal rudder-power, it is not easy to decide apart from trial. The contrast needs no further comment; it is generally admitted that very great advantages are obtained by adopting moderate lengths in war-ships and accepting the greater expenditure of steam-power. As speeds are increased so the limit of length must be raised which would give the best combination of qualities; and if higher speeds than 15 or 16 knots per hour are desired, greater lengths than 300 to 325 feet must be accepted.

From the tabular statement given above, it will appear that one important item in which the *Heracles* gains upon her rival is in the weight of belt armour, the length of water-line to be protected being less. This matter—the area requiring to be protected—must exercise great influence upon the selection of the forms and proportions most appropriate in ironclads. In the design of central-citadel ironclads another consideration has weight, viz. the selection of proportions which shall secure sufficient stability for the ships when their unarmoured ends are riddled. The *Inflexible*, for example, has a less ratio of length to breadth ($4\frac{1}{2}$ to 1) than any ironclad of equal speed yet designed; but by fining the extremities and making other modifications in form her performance compares favourably with that of other vessels of recent design with equal length, greater draught, and ratios of length to breadth of 5 or $5\frac{1}{2}$ to 1. The “displacement coefficient” of the *Inflexible* at 14 knots is nearly 190: that for the *Alexandra*, of equal length, nearly $11\frac{1}{2}$ feet less beam, and nearly 2 feet greater draught, with 2000 tons less displacement, is 175 for 15 knots, and at 14 knots would probably be about equal to the coefficient of the *Inflexible*.

In the ironclad reconstruction, as armour has been thickened, the ratio of length to breadth has been reduced; and so far as the Royal Navy is concerned, there is no reason to suppose that anything but advantage has resulted from the change. It is possible, however, that the resistance at the high speeds of 14 or 15 knots, considered necessary in battle-ships, would become so great in vessels having extremely large ratios of breadth to length as to make it impolitic to adopt such proportions. The extreme case of the Russian circular ironclads will enable fuller explanations to be given on this point; and the extraordinary character of these vessels will appear from the following brief statement.

The vessels were originally designed for coast-defence services in the shallow waters of the Black Sea; it was desired that they should carry thick armour and heavy guns; and the circular form was chosen because it gave the least surface and the greatest carrying power in proportion to the displacement. It may be admitted that, if these vessels had been stationary floating forts, this view of the matter would have been correct; in the completed ships the hull is said to weigh only about *one-fifth* of the displacement, whereas in vessels like the *Devastation* about 30 or 35 per cent. of the displacement is expended on the hull. But when from mere stationary flotation we pass to the case of loco-

motion even at moderate speeds, the conditions are far less favourable to the circular form. It is admitted as the result of careful experiments made by Mr. Froude, and confirmed by the performances of the *Novgorod*, that a circular ship experiences about *five times* as great resistance as a ship like the *Inflexible* or *Devastation* moving at equal speed. Let it be supposed that a circular ship is required to be built to steam as fast and as far as the *Devastation*, and to carry the same dead weight of armour, guns, &c., exclusive of engine and coals. The same type of engine is to be used in both cases, and the rate of coal consumption is to be identical in both. Taking the Parliamentary Return for the *Devastation*, it appears that the following is the distribution of weights :—

Engines (developing 6600 horse-power)	. 1000 tons.
Coals 1350 „
Hull 2880 „
Dead weight carried 4070 „
—	
Total displacement 9300 tons.

The engines of the *Devastation* are of the surface-condenser type, which preceded the compound principle now generally adopted; and they consume about $3\frac{1}{4}$ lbs. of coal per indicated horse-power per hour. Had they been of the latest compound type, about 900 tons of coal would have sufficed to carry the ship as far as she can steam with her present engines, and the engines might have been only a little heavier (see page 526). Suppose that the total weight of engines and coals remains as in the actual ship, and that the coals carried amount to 1200 tons, we shall have converted the *Devastation* into a ship with modern engines, and assumed a coal supply less than she could actually carry. What would be the dimensions of the corresponding circular ship? is the question to be solved. Using the *data* furnished by Captain Goulaeff, of the Russian navy,* who argued strongly in favour of the novel type, it appears that the displacement of a circular vessel carrying 4070 tons dead weight, exclusive of engines and coals, and steaming as fast and as far as the *Devastation*, would be at least 20,000 tons. The weights would be distributed somewhat as follows :—

* In a Paper published in the *Transactions* of the Institution of Naval Architects of 1876.

Engines (developing about 34,000 horse-power)	. 6,000 tons.
Coals (to steam $7\frac{1}{2}$ days at full speed)	. . . 6,100 „
Hull (20 per cent. of displacement)	. . . 4,000 „
Dead weight (as in <i>Devastation</i>)	. . . 4,070 „
<hr/>	
Total displacement	. . 20,170 tons.

If the proportions of the existing ships were followed, this vessel would be about 230 feet in diameter, and $19\frac{1}{2}$ feet draught. The circumference at the water-line would be about 720 feet; whereas the total length of the water-line requiring to be armoured in the *Devastation* would not exceed 640 feet; and consequently an armour belt of equal depth and thickness on the two ships would weigh about one-eighth more for the circular ship than for the *Devastation*. The deck area of the circular ship would be about 41,000 square feet; the corresponding area in the *Devastation* would not exceed *one-third* that for the circular ship; and here, for equal protection, the *Devastation* would be at a great advantage. On the upper and breastwork decks of the *Devastation*, the mean thickness of the plating may be taken at $2\frac{1}{4}$ inches; the total weight is about 500 tons. On the circular ship, $2\frac{1}{4}$ -inch plating over the whole area of the deck would weigh about 1600 tons.

It is needless to pursue this investigation further, for no one is likely to contemplate the construction of a vessel nearly twice as heavy as the heaviest existing ships, when it can be shown that the circular form compares so disadvantageously with other existing types. Moreover, it has yet to be proved that vessels of the circular form can be driven at such speeds as 14 knots, without serious departures from the normal trim and draught. Mr. Froude stated, as the result of experiments with circular models, that, as the speed is increased, the vessels "dive" below their normal draught; and this circumstance deserves careful consideration in discussion of the merits of such ships. The existing ships are reported to have made very low speeds, from 7 to 10 knots, although they have a very large amount of engine-power in proportion to their displacement. The *Novgorod*, for example, had engines of 480 nominal horse-power, said to develop about 2200 horse-power (indicated); her displacement is 2490 tons; and the speed about $7\frac{1}{2}$ knots. Contrasting this with the performance of the monitor *Abyssinia*, which, with a displacement of 2800 tons, was driven $7\frac{1}{3}$ knots by 560 indicated horse-power, the reader will obtain another proof of the extrava-

gant expenditure of power required in the circular ships. For their special purpose they may be exceedingly well adapted, but they cannot be regarded as models for general service. At the same time, the information derived from their performances is most valuable and instructive.

The same remark applies to the performances of the Imperial Russian yacht *Livadia*. She is 235 feet long, 153 feet broad, and on the measured-mile trial had a displacement of about 4400

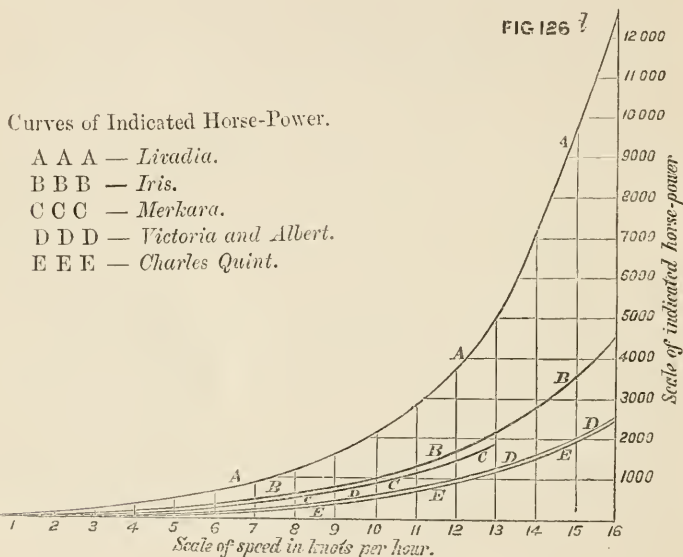

tons, on a draught of about 7 to 8 feet. With 12,350 indicated horse-power she is said to have attained a speed of 15·725 knots per hour; with 10,200 horse-power, a speed of 14·83 knots; with about 4800 horse-power 13 knots, and with 3000 horse-power 11 knots. In Fig. 126*d*, the curve A A A shows the curve of indicated horse-power based on these figures, the construction being similar to that explained for Fig. 126*a*, page 557. For purposes of comparison there also appear the corresponding curve B B B for Her Majesty's ship *Iris*, the curve C C C for the *Merkara* cargo and passenger steamer built by Messrs. Denny (mentioned on page 459); the curve D D D for Royal Yacht *Victoria and Albert*; and the curve E E E for the fast passenger steamer *Charles Quint*, built by Messrs. Inglis. The Table on opposite page gives the principal particulars of the vessels thus compared:—

It is unnecessary to comment on the great proportionate expenditure of power in the *Livadia* as compared with the other vessels, but it should be noted that her displacement being greater than that of the other ships somewhat favours her in the comparison of the ratios of horse-power to displacement. When compared with short bluff-formed armoured ships designed to steam only at low speeds, the *Livadia* does not show so badly. For example, the *Hotspur* ironclad ram of the Royal Navy is 235 long, 50 feet beam, and on trial drew 20½ feet, with a displacement of 4180 tons. Her speed of 11·3 knots was attained with 1980 indicated horse-power. The *Livadia* is said to have required 3000 horse-power for 11 knots speed, and the greater constant friction of her engines would necessarily tell against her at this low speed. But allowing for this the expenditure of

Ships.	Length.	Breadth extreme.	Measured Mile.	
			Mean Draught.	Displacement.
	feet	feet	feet	tons
<i>Livadia</i>	235	153	7½	4400
<i>Iris</i>	300	46	18	3290
<i>Merkara</i>	370	37½	17	3980
<i>Victoria and Albert</i> . .	300	40½	14	2000
<i>Charles Quint</i>	315	33½	14½	2480

power—measured by its ratio of horse-power to weight driven—must have been about 40 per cent. greater in the *Livadia* than in the *Hotspur*. Other comparisons have been made somewhat more favourable to the *Livadia*,* but it is unnecessary to reproduce them here. It must suffice to say that her trials have demonstrated one very interesting fact, viz., that if the necessity arises, in vessels of moderate speed and a given length and displacement, it is possible to exchange the ordinary form of midship section (where the draught of water is about half the extreme breadth) for a very broad shallow section of equal area; and by making suitable changes in the other cross sections so as to favour a considerable amount of fineness in the longitudinal sections (buttock and bow-lines) to obtain the given speed with from 30 to 50 per cent. more power than would be required in the ship of ordinary form.

* See Captain Goulaeff's Paper in the *Transactions* of the Institution of Naval Architects for 1881.

As compared with the circular form, the *Livadia* will be seen to have a distinct advantage. This arises from two causes. When towed at speeds varying from 7 to 13 knots, the *Livadia* model is said to have experienced only about 60 per cent. of the resistance experienced by a model of one of the circular ships having equal displacement. Moreover, her three screws are much better placed than the multiple screws of the circular ships, being far more clear of the hull, having a better supply of water, and causing less augment of resistance. Notwithstanding this improvement in performance, it cannot be admitted that the *Livadia* form is well adapted for use in protected war-ships; and for the ordinary purposes of navigation it does not seem likely to be accepted. As regards the former statement, it may be explained that the *Livadia* form, besides being more expensive in propelling-power and coal-consumption, has such an enormous area of the plane of flotation that a very great weight of horizontal or oblique armour would be required. For example, in a comparison which we have made between Her Majesty's ship *Alexandra* and an enlarged *Livadia*, the figures stand approximately as follow :—

	<i>Alexandra.</i>	Enlarged <i>Livadia.</i>
Length	325 feet	300 feet
Breadth	63 feet 10 inches	200 feet
Draught (mean).	26 feet 6 inches	11 to 12 feet
Displacement (tons).	9500	9500
Indicated horse-power	8600	12,500 to 13,000
Speed.	15 knots	15 knots

This increase in engine-power would necessitate a proportionate increase to weight of machinery and coals; there would be practically the same length of water-line to protect, and the area of deck requiring horizontal armour would be about double that of the *Alexandra*. Hence it follows that on the *Livadia* form the association of speed, coal-endurance, armour and armament actually existing in the *Alexandra* could not be repeated. It might be possible, of course, to adopt the *Livadia* form in connection with some entirely new disposition of the armament or the protective material, but we cannot pursue the subject further here.

For any selected type economical propulsion is favoured by *increase in size*. This is true generally, and has been mentioned in previous chapters. If the particular case is taken where the

resistance varies with the wetted surface, and as the square of the speed, this relative economy is easily illustrated. Suppose two similar ships to be compared, the weight of one being W_1 and that of the other W_2 . Let D be the ratio which the length or any other dimension in the larger ship bears to the corresponding dimension in the other. Then it must follow that

$$W_1 = D^3 \cdot W_2,$$

the weight increasing with the *cube* of the ratio of corresponding dimensions. On the other hand (as explained at page 495), the resistances will bear to one another the ratio of the *two-thirds* power of the displacement; and if R_1, R_2 represent the resistances,

$$\frac{R_1}{R_2} = \left(\frac{W_1}{W_2}\right)^{\frac{2}{3}} = D^2 = \frac{1}{D} \times \frac{W_1}{W_2},$$

the resistance increasing only with the *square* of the ratio of corresponding dimensions. For instance, a ship *twice* as long, *twice* as broad, and *twice* as deep as another will have *eight* times as great displacement, but, when moving at the same speed, will experience only *four* times the resistance, and require only *four* times the engine-power. No doubt the longer ship would require to have greater structural strength than the smaller; and consequently the hull might have to be made somewhat heavier in proportion to the displacement, although in actual practice this is often not done. But even supposing this additional weight of hull were allowed, the larger ship would be far more economical of steam-power in proportion to the dead weights carried.

As an illustration, take the following comparison between two merchant steamers whose performances on the measured mile were recorded, their forms being similar:—

Particulars.	Steamer A.	Steamer B.
Displacement	1830 tons	3660 tons
Indicated horse-power	1620 H.P.	2430 H. P.
Speed	12.9 knots	12.95 knots
Indicated horse-power } (Displacement) ^{2/3} }	10 ^{3/4}	10 ^{1/4}

The last line in this comparison shows that the assumed law holds very closely in these ships. If these vessels were fitted with compound engines, and employed on a service where they

would have to steam 3000 knots at full power, their weights would be distributed somewhat as follows:—

Distribution of Weights.	Steamer A.	Steamer B.
Weight of engines, &c.	Tons. 320	Tons. 480
„ „ coals	360	540
„ „ hull	550	1240
	1230	2260
„ „ cargo and equipment	600	1400
Displacement	1830	3660

The expenditure of 360 tons of coal in the smaller vessel would carry only 600 tons of cargo and equipment over the distance named; adding 50 per cent. to this expenditure, the larger ship can carry more than twice as much cargo and equipment. This comparison, of course, takes no account of the relative first cost of the two vessels.

Irrespective of any assumed law of resistance, it is possible in general terms to indicate the economy of propulsion obtained by increase in size. Using the same notation as before, let the two ships compared be supposed moving at the speed V , their resistances, excluding the frictional resistances on the bottoms, being R_1 and R_2 . Let R be the resistance of the smaller vessel when moving at the speed $V \div \sqrt{D}$; and let it be supposed that between this speed and the speed V the resistance varies with some unknown power ($2n$) of the speed. Then

$$\frac{R}{R_2} = \left(\frac{V}{\sqrt{D}} \right)^{2n} \times \frac{1}{V^{2n}} = \frac{1}{D^n}; \text{ whence } R = \frac{R_2}{D^n}$$

Also, by the law of comparison which Mr. Froude has established,

$$R_1 \text{ (for large ship)} = D^3 \times R = D^{3-n} \cdot R_2,$$

$$\frac{R_1}{R_2} = a = D^{3-n};$$

and, as before,

$$W_1 \text{ (for large ship)} = D^3 \cdot W_2; \text{ whence } \frac{W_1}{W_2} = b = D^3;$$

so that finally, for equal speeds of two similar ships,

$$\frac{1}{D^n} \cdot \frac{W_1}{W_2} = \frac{R_1}{R_2}; \text{ or } \frac{a}{b} = \frac{1}{D^n}.$$

The greater the value of n for a certain value of D , the less will be the ratio $a : b$ measuring the ratio of the increased resistance, involved in enlarging the ship, to the corresponding increase in displacement and carrying-power. If the resistance between the speeds V and $V \div \sqrt{D}$ varies as the *square* of the speed, $n = 1$, and the final equation assumes the form

$$\frac{1}{D} \cdot \frac{W_1}{W_2} = \frac{R_1}{R_2},$$

agreeing with that previously obtained for the law of variation. But if the resistance between the speeds V and $V \div \sqrt{D}$ varied as the *fourth* power of the speed, then $n = 2$, and we have

$$\frac{1}{D^2} \cdot \frac{W_1}{W_2} = \frac{R_1}{R_2}.$$

If the resistance of the smaller vessel between the speeds V and $V \div \sqrt{D}$ varies as the *sixth* power of the speed, then $n = 3$,

$$\frac{1}{D^3} \cdot \frac{W_1}{W_2} = 1 = \frac{R_1}{R_2},$$

that is to say, the small ship would experience as great a resistance at the speed V as the larger ship of similar form if the foregoing assumptions held good. As a matter of fact, however, whatever may be the law of variation in the wave-making resistance in terms of the speed, the frictional resistance does not vary more rapidly than the square of the speed, and this would make the resistance of the smaller vessel less than that of the larger.* It is easy to make the necessary correction for friction in the manner explained on page 472.

The comparison of the *Merkara* and *Greyhound* type will furnish a good illustration of the foregoing equations. At 12 knots, for the *Merkara*, n may be taken as *unity*, and for the *Greyhound* as 2 nearly; in both ships $R_2 = 20,000$ lbs. Suppose both vessels to have their lengths and other dimensions increased by one-third; then $D = 1\frac{1}{3}$. The *Merkara* has a displacement of 3980 tons; the *Greyhound* one of 1160 tons; the enlarged *Merkara* would weigh 9430 tons, the enlarged *Greyhound* about 2750 tons.

* For some interesting graphic illustrations of the above equations, see a Paper by Mr. Biles in the *Transactions*

of the Institution of Naval Architects for 1881.

For enlarged *Merkara*, $R_1 = 20,000 \times \left(\frac{4}{3}\right)^2 = 35,555$ lbs.

For enlarged *Greyhound*, $R_1 = 20,000 \times \frac{4}{3} = 26,666$ lbs.

The *Greyhound* type, therefore, gains more in economy of propulsion by enlargement than does the *Merkara*; although the latter type benefits considerably by the same process, and would have much greater carrying-power in proportion to the expenditure of fuel as the size increased.

To the foregoing considerations, which have had regard only to smooth-water performances, it is necessary to add one remark. In ocean steaming, the longer, larger, heavier ship is far more likely to maintain her speed under varying circumstances of wind and sea than is the smaller vessel. These two sources of gain in larger ships fully explain the general adoption of the policy which has resulted in very large increase of the sizes of ocean steamers.

Increase in size and variation in proportions may, as explained in Chapter X., affect the ratio which the weight of hull bears to the displacement. No general law can be stated for this ratio; but it is obvious that, whereas in small ships of moderate length and proportions, the scantlings which give sufficient local strength also give an ample margin of strength against the principal strains, the reverse may hold good, at least for certain portions of the structures, in ships of extreme lengths and proportions. The longer, larger vessel might, therefore, have a relatively heavier hull, and this increase in weight of hull must be set against the proportionate saving on propelling apparatus and coal. There is reason to believe, however, that the balance of advantage in a commercial sense on long voyages must always remain with the larger ship when the difference in size is considerable. As an example take the *Merkara* and the enlarged *Merkara* mentioned above. If 1600 horse-power was required to drive the *Merkara* 12 knots, 2800 horse-power would suffice for the latter. For voyages of equal length at that speed the weights of coal burnt would bear to one another the same ratio as the horse-powers. Take 400 tons for the weight of engines, &c., for the smaller ship; then 700 tons will be about the corresponding weight for the larger ship; if the *Merkara* be credited with a coal supply of 500 tons, the larger ship should carry about 880 tons. Suppose further that in the *Merkara* the hull weighs 33 per cent. of the displacement, as is common in iron cargo-ships; whereas in the larger

ship it is increased to 40 per cent.: then in the *Merkara* there will remain 1800 tons available for cargo and equipment, which can be propelled over a certain distance by an expenditure of 500 tons of coal, as against 4100 tons in the large ship, which requires an expenditure of less than 900 tons of coal for an equal distance.

Side by side with the development of the sizes and speeds of ocean steamers, there has recently been progressing the construction of a class of very small vessels, possessing remarkably high speeds—the so-called “swift steam-launches” and torpedo-boats. Vessels of from 50 to 100 feet in length have been driven at speeds of from 16 to 23 knots per hour in smooth water, considerably exceeding the measured-mile speeds of the fastest sea-going ships. The earliest examples of these swift boats were designed and built by Mr. Thornycroft about 1862, and the type has since received some of its most important developments in the successive vessels built by his firm.* Mr. Yarrow also has built a large number of very fast boats for torpedo and other services. Allusions have been made to the remarkable performances of these small vessels in previous pages. The extraordinary features in their curves of resistance, the wave-phenomena attending their motion at high speeds, and their behaviour in relation to the surrounding water have been discussed on page 466. The principal characteristics of their machinery have been described on page 523. But it is impossible to consider the results attained in these vessels without being led to the consideration of the possibility of applying similar methods of construction on a larger scale to ships employed on distant voyages. It may well happen, as before remarked, that from the study of this problem further progress may result; and in stating some of the difficulties to be overcome, we do not desire to express a contrary opinion.

First of all, then, it must be noted as a direct consequence of the law of “corresponding speeds,” that the very advantageous conditions of resistance attained by these torpedo-boats at speeds of 16 to 22 knots per hour could not be reached in larger ships until extraordinary speeds had been attained. That law, it will

* For an excellent summary of information, see the Paper by Mr. Thornycroft in the *Proceedings* of the Institution of Civil Engineers, for

1881: and Papers by Mr. Donaldson, in the *Journal* of the Royal United Service Institution, for 1877 and 1881.

be remembered, states that corresponding speeds bear to one another the ratio of the *sixth roots* of the displacements. A large torpedo-boat is, say, 30 tons in displacement, and a despatch vessel, like the *Iris*, of 3700 tons displacement; the corresponding speeds are then related to one another in the ratio 1 : 2.2. Hence to speeds ranging from 16 to 22 knots in the torpedo-boats will correspond speeds of 35 to 50 knots in the ship. Up to 13 knots in torpedo-boats the resistance varies as the square or cube of the speed: similar laws of variation must hold for the despatch vessel up to 30 knots per hour. And if still larger ships are considered, the speeds corresponding to those where resistance grows slowly in the torpedo-boat are, of course, still higher. For a Transatlantic steamer of 10,000 tons displacement, for example, 13 knots in the torpedo-boat would be represented by 34 knots in the ship, and 22 knots in the torpedo-boat by nearly 60 knots in the ship. The highest speeds yet attained by first-class seagoing steamships of 9000 to 10,000 tons displacement are from 16 to 18 knots. Suppose speeds of 25 knots to be aimed at, then the corresponding speed of the torpedo-boat would be about 10 knots, at which the resistance is known to vary at a rather higher rate than the square of the speed.

It may be urged, of course, that if these high speeds were aimed at, forms would be selected differing greatly from those of the torpedo-boats, and making less proportionate resistance. This is quite possible, although the inquiry involved in this selection must be laborious, and could only be conducted by means of model experiments. Supposing it to be successful it must still remain true that at such high speeds very great resistances must be encountered in proportion to the displacements driven; and to overcome these resistances very great engine-powers will be needed. Hence it follows that the engineering problem to be solved in such cases will be not dissimilar to that so admirably dealt with in the torpedo-boats, viz.: how to minimise the ratio of the weight of the propelling apparatus to its power. From the remarks made on page 528, as to the unsuitability of the locomotive boiler for long-distance steaming, on account of its need of frequent cleaning and high rate of coal consumption, it will appear that a solution of the larger problem stated above has not yet been reached. But it may be; and by further improvements in engines and boilers, while maintaining the lightness which is essential, the equally essential economical ratio of coal consumption may also be secured.

The following table exhibits in a succinct form the expenditure of power required to attain certain measured-mile speeds in screw-steamers of different classes and sizes. For ships of the Royal Navy, speed trials are always made and recorded; for merchant ships corresponding trials are often omitted, or are made when the vessels are light. It will be understood therefore that, although the figures given for merchant ships are taken from good examples, they cannot be guaranteed to the same extent as those for war-ships.

Classes of Ships.	Measured-mile Speed.	Length.	Ratio of Length to Breadth.	Displacement.	Ratio of Indicated Horse-power to	
					Displacement.	(Displacement) ^{2/3}
<i>Ships of Royal Navy.</i>						
Ironclads:—						
Early types } single screw	{ 14 to 14½ 14 to 15 14 to 15	Feet. 380 to 400 300 to 350 280 to 320	6½ to 6¾ 5¼ to 5¾ 4½ to 5	Tons. 9000 to 10500 7500 to 9000 6000 to 9000	0.6 to 0.7 0.9 to 1 0.7 to 0.9	11 to 14 16 to 20 15 to 19
Recent types } single screw						
Recent types } twin-screw						
Unarmoured:—						
Swift cruisers	15 to 16	270 to 340	6½ to 6¾	3000 to 5500	1.3 to 1.5	20 to 24
Corvettes	12¾ to 13¼	200 to 220	6	1800 to 2000	1 to 1.2	13 to 14
Sloops	11	160	5	850 to 950	1 to 1.2	10 to 11
Gun-vessels	9½ to 11	125 to 170	5½ to 6¼	420 to 800	0.8 to 1.4	7 to 11
Gunboats (coast defence) .	8 to 9	80 to 90	3 to 3½	200 to 250	0.8 to 1.1	5 to 7
<i>Merchant Ships.</i>						
Largest mail steamers . . .	14 to 15	400 to 500	9 to 11	7500 to 10000	0.5 to 0.6	10 to 12
Smaller mail steamers . . .	13 to 14	300 to 400	8 to 10	5000 to 7000	0.4 to 0.5	7 to 10
Cargo-carrying steamers . .	11 to 13	250 to 350	7½ to 10	3000 to 6000	0.3 to 0.5	5 to 9
Ditto ditto	9 to 11	200 to 300	7 to 9	1500 to 4000	0.2 to 0.4	3 to 6

Although the table is confined to comparatively few classes, it represents the conditions of a very large number of ships, and may be of service in roughly approximating to the engine-power required in a new ship belonging to any of these classes. It also furnishes many illustrations of the effect of changes in the sizes and forms of ships upon economy of propulsion.

CHAPTER XIV.

THE STEERING OF SHIPS.

SHIPS are ordinarily manœuvred by means of rudders, sails, or propellers driven by steam-power. Steering by sail-power alone may be accomplished by the skilful seaman, if his ship has been well designed. Steering by the action of the propellers alone is also a possibility in certain classes of steamships, and this may be a great advantage under certain circumstances. Rudders are fitted, however, in all classes of ships, and form the most important means of controlling their movements under all ordinary conditions of service; so that in this chapter attention will be chiefly directed to the principles upon which the action of rudders depends. A brief notice will suffice respecting manœuvring by the use of propellers; but nothing will be said respecting manœuvring under sails alone, as that is peculiarly a matter of seamanship. The principal facts which concern the naval architect in arranging and distributing the sail-spread of a ship have been already discussed in Chapter XII.

The rudder is almost always placed at the stern of a ship, which is the most advantageous position for controlling her movements when she has headway. In what follows it will be understood therefore, that, unless the contrary should be stated, we are dealing with stern rudders. After discussing their action, a few remarks will be made respecting the use of bow rudders, auxiliary rudders, and other supplementary methods of increasing the turning power of ships.

Two kinds of rudders require to be noticed. First, the *ordinary* rudder, which rotates about an axis near its foremost edge, and is hung to the sternpost of the ship. Fig. 127 shows the common arrangement in a single-screw ship. AA is the *axis* of the rudder, the line passing through the centre of the pintles by which the rudder is hung to the after sternpost, or rudder-post. In the

plan, AB represents the rudder put over to port, the helm being a-starboard. In sailing ships, paddle-steamers, jet-propelled ves-

FIG. 127
Profile

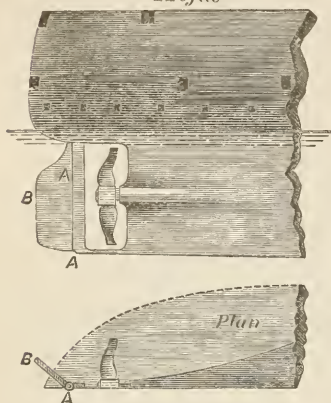

sels, and twin-screw ships, the ordinary rudder is hung to the after end of the ship, there being only one sternpost in such vessels. Fig. 128 shows the common arrangement in twin-screw ships; and, apart from the propellers, the drawing will also serve for the other classes named. A few ships have had the rudders placed before the single-screw propellers, but this is not a common plan; when it is adopted, the rudder is generally of the ordinary kind, and is placed in the after deadwood below the screw-shaft.

The second form to be noticed is the *balanced* rudder, which differs from the ordinary form in having a part of its area—usually about one-third—before the axis about which it rotates. This kind of rudder has been used in many steamships of the mercantile marine and the Royal Navy. Fig. 129 illustrates a

FIG. 128
Profile

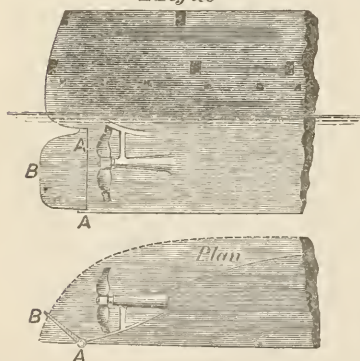

common arrangement: AA is the axis. It will be observed that there is no rudder-post, the weight of the rudder being taken inboard, and the lower bearing at the after end of the keel being made use of simply to steady the rudder. In some cases balanced rudders have been fitted without the lower bearing, the rudder-head being made exceptionally strong; but this plan has considerable disadvantages, especially as regards liability to derangement by

shocks or blows of the sea. Usually the balanced rudder is made in one piece, and, when put over, occupies a position similar to that indicated (in plan) by Fig. 130, the part AC before the axis A being rigidly attached to the part AB abaft it. When the rudder is thus made in one piece, it is termed a

“simple” balanced rudder. Experience has shown, however, that, while it is advantageous when a vessel is under steam, to use the large area of the balanced rudder, it may be preferable, when she is under sail alone, to use a less area. To enable both these objects to be attained, the so-called “compound” balanced rudder has been devised; it is fitted in Her Majesty’s ships *Hercules* and *Sultan*, and has proved very satisfactory. The part before the axis is attached to a hollow annular head; up through which passes the rudder-head which carries the after part of the rudder; and the two parts are hinged to one another along the axis. When the ships are under steam, the two parts can be locked together and made to act as a simple balanced rudder; when the ships are under sail, the fore part of the rudder can be locked fast in the line of the keel (as shown by AC, Fig. 131), occupying a position resembling that of the rudder-post in ordinary screw-steamers, and the after part alone (AB) is used to steer the ship.

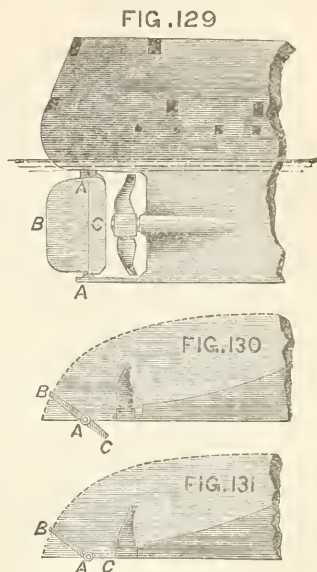

Both ordinary and balanced rudders may be regarded simply as plane surfaces which, by means of suitable mechanism, can be placed at an angle with the keel-line. It is customary to speak of the “angle of helm” rather than the rudder angle. “Helm a-starboard” means that the rudder has been put over to *port*, and that the head of the ship moves to *port*. “Helm a-port” means that the rudder has been put over to *starboard*, and that the head of the ship moves to *starboard*. A sailing ship has “weather-helm” when the rudder has been put over to the leeward side, in order to make the head of the ship fall off from the wind. When the helm is “a-lee,” the rudder has been put over to the windward side, in order to bring the head of the ship up to the wind.

In discussing the action of the rudder, it will be convenient to consider separately the following features:—

(1) The causes which produce, and govern the amount of, the pressure on the rudder, making it effective in turning a ship.

(2) The relation which exists between the pressure on the rudder and the force required at the tiller-end to hold the helm at any angle desired; as well as the work to be done in putting the helm over.

(3) The turning effect on a ship produced by the pressure on the rudder.

The first and second of these subdivisions are very closely connected; in discussing the third, it will be necessary to distinguish between, what may be termed, the *initial* motion of a ship when her helm is put over, and her subsequent motion when the speed of rotation has become approximately uniform.

When a rudder is placed obliquely to the keel-line of a ship, and streams of water impinge upon its surface in consequence of the motion of the ship, or the action of her propeller, the motions of these streams must be more or less checked or diverted, and a change of momentum is produced (see page 435), which reacts upon the rudder and causes a normal pressure upon its surface. If all these streams were moving with uniform velocity and in parallel lines before they impinged on the rudder, the normal pressure upon it could be estimated approximately by the rules stated for thin plates on page 436; and since rudders are commonly not wholly submerged, these rules would probably give somewhat less than the true pressure. In practice the streams impinging upon a rudder do not move in parallel lines or with uniform velocity; and to estimate strictly the normal pressure on a rudder it would be necessary to take account of the velocity and direction of motion of the water in each elementary stream, in order to determine the change of momentum. Approximate estimates suffice, however, for all practical purposes, and in making such estimates it is customary to express the speed of approach of the streams to the rudder either in terms of the speed of the ship or that of her propeller; assuming the same speed for all the streams. If the vessel is moving ahead in a straight course and her helm is put over, it is usual to assume that the streams are flowing parallel to the keel, and that the angle of obliquity to be used in estimating the effective pressure on the rudder is the angle which it makes with the keel. As soon as the turning effect of the rudder begins to be felt by a ship, and she acquires angular motion as well as translatory motion, the conditions are altered, and the effective angle of obliquity of the rudder is usually made less than its angle with the keel. This has been proved experimentally and will be made the subject of further remark (on page 626), when considering the phenomena

attending the turning of ships. It may be added that for the purposes for which approximate estimates of the rudder pressure are made, it is safer to take the helm-angle with the keel as the effective angle of obliquity.

Although these assumptions are commonly made in calculations for the sizes and strengths of rudders and steering gear, no one supposes them to strictly represent the facts, even in the simplest case, such as that of a sailing ship running dead before the wind. From the explanations given on page 441, as to the stream-line motions at the stern of a sailing ship thus circumstanced, it will appear that the speeds and directions with which the streams impinge upon the rudder will vary with the headway, the form of the stern, the roughness of the bottom, and the helm angle. When a ship is not running before the wind, she has leeway as well as headway, and is inclined to the upright, all of which circumstances affect the stream-line motions, and the normal pressure on the rudder; but their influence cannot be exactly estimated, and is of little practical importance.

In any case, however, the rudder pressure which is effective for turning a ship has no connection with the hydrostatical pressure which would be acting upon the surface, if the rudder were put over to any angle when the ship was at rest in still water. This distinction is mentioned because some persons have confused hydrostatical pressure, with the pressure or reaction due to the relative motion of the streams and the rudders, and have proposed to shape the rudder according to laws based upon this wrong assumption. The mistake made is similar to that referred to at page 435, as to the relative resistances of a plane surface wholly or partly submerged; but there can be no question that without motion of the ship, or of the water past the ship, the rudder can have no steering power.

Paddle-wheel steamers and jet-propelled vessels differ somewhat from sailing ships in their steerage-power. The latter require to be in motion if the water is still—to have “steerage-way”—before the rudder can act; but the former may acquire steerage-power with little or no headway by means of the action of their propellers. If the wheels of a paddle steamer are started, for example, when she is at rest in still water, a paddle-race is driven astern at considerable speed on each side; and it is a matter of common experience that this motion of the race relatively to the rudder will develop an effective pressure and bring the ship under control by her rudder, before she has gathered much headway. It is probable that similar conditions hold good in jet-

propelled vessels, although experience with them is limited. In both these classes of vessels, however, when their speed has been increased by the continued action of the propellers, and approximately uniform motion has been attained, the influence of the propeller-race becomes far less, and the steering-power of the rudder is governed mainly by the speed of the vessel, the fineness of the run, and other conditions closely agreeing with those described for sailing ships.

The steerage of screw steamers presents certain special features deserving careful consideration. In single-screw ships as ordinarily constructed, the propeller is situated immediately before the rudder; when a vessel is moving ahead the race is driven aft more or less directly upon the fore side of the rudder, and when she is moving astern the action of the propeller induces a forward pressure on the after side of the rudder. The particles of water in the propeller-race have rotary as well as sternward motion communicated to them (see page 544) and, moving in more or less spiral paths, impinge upon the rudder in directions which may depart widely from parallelism with the keel-line. Experiments have been made to determine the "position of zero-pressure" for rudders placed behind single-screws, and they indicate clearly the obliquity of the motion of the streams in the race. Herr Schlick, for example, divided an ordinary rudder into two equal parts, in the steamer *Vinodol*; the line of section being horizontal. When the screw was at work the lower half found its position of rest at an inclination of rather less than 10 degrees on one side of the keel-line, while the upper half rested at nearly an equal inclination on the other side of the keel-line. In other cases the helm has been left free while the screw was at work, and the rudder has been found to rest at a sensible angle to the keel-line, the effective pressure of the streams delivered by the lower blades being predominant over that of the streams delivered by the upper blades. This position of rest or zero-pressure is clearly that from which the effective rudder-angle should be reckoned, and not from the keel-line, in estimating the initial pressure on a rudder put over when a screw-ship is proceeding on a straight course. Further it will be noted that to obtain equal pressures on opposite sides of the keel the helm must be brought to a greater angle with the keel-line on one side than on the other. This has been considered disadvantageous, and various proposals have been made to remedy the supposed loss of efficiency (see page 642); but they have not found favour in practice.

The influence of the propeller upon the steerage of single-screw

ships is illustrated by the well-known practice of "slewing" ships completely round in a very limited space. Suppose a vessel to be at rest in still water, and that her screw is started ahead; it delivers a race having considerable sternward velocity and thus gives good steerage-power before the vessel has gathered headway. The head of the ship begins to turn, say to starboard, the helm being a-port; and when headway is becoming sensible the engines are reversed, the helm put a-starboard, and by the action of the screw a pressure is developed on the aft side of the rudder tending to augment the previous motion of the head of the ship to starboard. In this manner, by suitable manipulation of engines and rudder, the ship can be turned completely round in a very small space, if that manœuvre should be thought necessary. The time occupied in turning would, of course, be considerable as compared with that needed for turning under-way.

Twin-screws, placed in the manner indicated in Fig. 128, are not so favourably situated as single-screws for influencing the effective rudder-pressure by the motion of the race. But the same kind of influence is exerted to some extent; and to give it marked effect, rudders of large longitudinal dimensions have been fitted in many recent twin-screw war-ships. These broad rudders sweep out to a considerable distance from the keel-line, even for moderate helm-angles, and their after parts, at least, come fully under the influence of the screw-race. Experience shows this simple expedient to be very effective, one of the most recent examples being found in the *Inflexible*, where an addition fitted to the after part of the rudder caused a sensible improvement in the steering. No serious difficulty is encountered in the steering of twin-screw ships when proper care is bestowed upon the rudder and steering gear, and it will be seen that the facts as to the turning trials of twin-screw ships given at the end of this chapter confirm this statement.

So far as the action of the rudder is concerned, therefore, the form of the after part of either single or twin-screw steamers is not so important as it is in sailing, paddle, or jet-propelled vessels; but it has been shown (on page 550) how necessary to the efficiency of screws as propellers is fineness of form in the after body.

Broadly speaking, it may be said that, when a screw steamer is moving ahead, the velocity with which the streams impinge upon her rudder, if placed abaft the screw, equals the *speed of the screw*, and therefore equals the sum of the speed of the ship and slip of the screw. When the slip is considerable, as it may be

in some cases, the increase in rudder-pressure and steering effect above that due to the headway of the ship may be a most valuable element in her handiness. Similar reasoning applies to the case where the propeller is driving a ship astern at a steady speed. But the most important case of screw-ship steerage is that when, to avoid a collision or any other danger, the engines of a screw steamer are suddenly reversed, say, from full speed ahead to full speed astern. The vessel will then maintain headway for a short time, but the effect of the propeller race upon the rudder may more than counterbalance the effect of headway, and the vessel may steer as if she were moving astern, the resultant pressure being delivered upon the after surface of the rudder.

This feature of screw-ship steerage has long been known. An experiment was made with the *Great Britain* in 1845; and it was found that, when the vessel was going astern at the rate of 9 or 10 knots, if the engines were rapidly reversed, she steered immediately as if she were going ahead. Similar experience appears to have been gained with the *Archimedes* and other early screw steamers. Further experiments of a more detailed character have been made recently by a Committee of the British Association, appointed in consequence of action taken by Professor Osborne Reynolds. The main purpose of the inquiry was to discover the best rules for the guidance of ships' captains in endeavouring to avoid collisions; and the following extracts from the final Report summarise the principal conclusions reached after making numerous experiments. There are some parts of this summary to which further reference will be made; and the second paragraph is that which is most closely related to the matter now under discussion.

“It appears, both from the experiments made by the Committee, and from other evidence, that the distance required by a screw steamer to bring herself to rest from full speed by the reversal of her screw, is independent, or nearly so, of the power of her engines, but depends upon the size and build of the ship, and generally lies between four and six times the ship's length. It is to be borne in mind that it is to the behaviour of the ship during this interval, that the following remarks apply.

“The main point the Committee have had in view has been to ascertain how far the reversing of the screw in order to stop a ship did, or did not, interfere with the action of the rudder during the interval of stopping; and it is as regards this point that the most important light has been thrown on the question

“of handling ships. It is found an invariable rule that, during
“the interval in which a ship is stopping herself by the reversal
“of her screw, the rudder produces none of its usual effects to
“turn the ship; but that under these circumstances the effect of
“the rudder, such as it is, is to turn the ship in the opposite
“direction from that in which she would turn if the screw were
“going ahead. The magnitude of this reverse effect of the rudder
“is always feeble, and is different for different ships, and even for
“the same ship under different conditions of lading.

“It also appears from the trials that, owing to the feeble
“influence of the rudder over the ship during the interval in
“which she is stopping, she is then at the mercy of any other
“influences that may act upon her. Thus the wind, which
“always exerts an influence to turn the stem (or forward end) of
“the ship into the wind, but which influence is usually well
“under control of the rudder, may, when the screw is reversed,
“become paramount, and cause the ship to turn in a direction
“the very opposite of that which is desired. Also the reversed
“screw will exercise an influence which increases as the ship’s
“way is diminished to turn the ship to starboard or port, accord-
“ing as it is right or left handed: this being particularly the case
“when the ships are in light draught.”

“These several influences, the reversed effect of the rudder, the
“effect of the wind, and the action of the screw, will determine
“the course the ship takes during the interval of stopping. They
“may balance, in which case the ship will go straight on: or any
“one of three may predominate and determine the course of the
“ship. The utmost effect of these influences when they all act
“in conjunction—as when the screw is right handed, the helm
“starboarded, and the wind on the starboard side—is small as
“compared with the influence of the rudder as it acts when the
“ship is steaming ahead. In no instance has a ship tried by the
“Committee been able to turn with the screw reversed on a circle
“of less than double the radius of that on which she would turn
“when steaming ahead. So that even if those in charge could
“govern the direction in which the ship will turn while stopping
“she turns but slowly, whereas in point of fact those in charge
“have little or no control over this direction, and unless they are
“exceptionally well acquainted with their ship, they will be un-
“able even to predict the direction.”

Summing up these remarks on the causes which govern the
pressure on the rudders of different classes of ships, it may be
said generally that without motion of a ship through the water,

or of the water past the rudder, it can have no steering power. A ship or boat anchored in a tidal current or river may be turned to some extent from the line of flow by the action of her rudder, because the water has motion relatively to the rudder. A ship almost destitute of headway may be under command, if her propeller is at work and delivering a race which flows past the rudder. But for a ship at rest in still and undisturbed water the rudder is powerless. The hydrostatical pressure sustained by the sides of the rudder, if held at any angle, balance one another, and are obviously quite distinct from the reaction due to change of momentum in streams having motion relatively to the rudder.

In all cases of relative motion of water and rudder the normal pressure depends upon the area of the immersed part of the rudder; the angle of its obliquity to the position of zero-pressure, or, roughly speaking, to the keel-line; and the speeds and directions with which the streams impinge upon the rudder-surface. In sailing ships the motions of the streams depend principally upon the motions of the ships, and the forms of the after body. In paddle steamers and jet-propelled vessels similar considerations are most influential, although the action of the propellers may influence the steerage of ships starting from rest, or reversing their course. In screw steamers the action of the propellers is most important, especially when the slip is considerable, and the velocity of the race is high.

It must be added that, when ordinary rudders are employed, and hung either to a broad rudder-post abaft the screw, as in Fig. 127, or to the body of the ship, as in Fig. 128, the check put upon the motion of the streams by the rudder must produce a reaction and pressure not merely upon the rudder itself, but upon the portion of the stern-post or deadwood adjacent to the rudder. This additional pressure will be delivered on the side towards which the rudder is put over, and there is good reason for believing that it considerably assists the rudder pressure in steering a ship, being most valuable in cases where the rudder is hung to the body of the ship. With simple balanced rudders placed as in Fig. 130, there is no corresponding pressure on the deadwood, but instead of it a normal pressure on the additional rudder-area placed before the axis. Compound balanced rudders, with the forward part locked fast (as in Fig. 131), of course, resemble the case illustrated in Fig. 127 for an ordinary rudder.

Besides these normal pressures on the rudder, sternpost, and deadwood, there will be a certain amount of *frictional* resistance on the rudder surface when placed obliquely; but this is of little

importance, as compared with the normal pressures, except for very small angles of helm: and, so far as it produces any effect on the steering, it will act against the normal pressures.

Next: reference must be made to the force required at the tiller-end to hold the rudder at any angle. This will, of course, depend upon the length of the tiller and the mode of applying the force; but it may be assumed that both these conditions are given. In Fig. 132 an ordinary rudder is shown. The resultant pressure upon it is P , acting through the centre of effort C of the immersed rudder-area. AT represents the tiller, Q the force required at its end, if applied normally to the tiller, in order to

FIG. 132

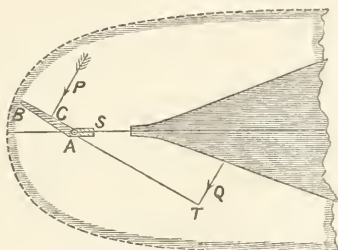

hold the rudder over. Apart from friction of the pintles, rudder bearings, collar, &c., we should have,

$$P \times AC = Q \times AT.$$

These frictional resistances vary considerably in different vessels, but may be made comparatively small by means of careful arrangements; in most cases they probably act with the force Q in resisting the motion of the rudder back towards the keel-line. Neglecting friction, and supposing the other conditions fixed, the force Q at the tiller-end will vary with the distance AC of the centre of effort from the axis of the rudder. On the same assumption the force Q may be determined approximately for any helm-angle, if the distance AC is known, since the normal pressure P can be estimated roughly in the manner described on page 436. In practice the maximum helm-angle varies from 30 to 45 degrees; so that inquiries as to the variation in the value of AC need not be carried beyond 45 degrees except it be done for scientific purposes. Formerly it was assumed that the centre of effort coincided with the centre of gravity of the immersed area of the rudder, and that the pressure due to the reaction of the streams

was uniformly distributed over that area. Experience and investigation have proved this view to be incorrect for a thin plate set obliquely to the line of motion, and for actual rudders. In the case of balanced rudders, for example, it has been ascertained that, when the area before the axis was about one-half as great as the area abaft the axis, a dynamometer attached to the tiller-end when at 40 degrees indicated little or no strain, showing that the centre of effort was then practically coincident with the axis. With ordinary rudders a similar excess of pressure probably exists on the forward part; although it is conceivable that in twin-screw ships the more direct action of the race on the after part of the rudder may tend to modify the position of the centre of effort. If the rudder be treated as a rectangular plate advancing obliquely, its leading edge (corresponding to the fore edge of a rudder) may be regarded as continually entering water which was comparatively little disturbed by the previous motion, and which, therefore, reacts more powerfully on that part of the area than does the water which impinges upon the after part, and which had been previously disturbed by the motion of the plane. This matter has been dealt with mathematically by Lord Rayleigh and experimentally by M. Joëssel, the late Mr. Froude and others. For a rectangular plane of breadth b , the distance d of the centre of pressure from the forward edge has been expressed by the following formulæ; a being the angle made by the plane with its line of motion:

$$\text{Lord Rayleigh} \quad . \quad . \quad d = \frac{b}{2} - \frac{3}{4}b \cdot \frac{\cos a}{4 + \pi \sin a}.$$

$$\text{M. Joëssel} \quad . \quad . \quad . \quad d = \cdot 195 b + \cdot 305 b \cdot \sin a.$$

Herr Hagen, after numerous experiments on comparatively small planes, proposed the following approximate formula: *

$$d^2 = (b - d)^2 \cdot \frac{a^\circ}{90^\circ}.$$

For angles below 10 degrees there must obviously be considerable difficulty in determining experimentally the value of d ; but from 10 degrees up to 45 degrees there is greater certainty. The results obtained independently by Mr. Froude and M. Joëssel agree closely with one another, and confirm the general accuracy of Lord Rayleigh's formula. At 10 degrees the centre of effort is about *one-fourth* the breadth from the leading edge; at 20 degrees

* See the abstract of his original Paper published in vol. 56 of the *Proceedings* of the Institution of Civil Engineers.

about *three-tenths* of the breadth; at 30 degrees *three-eighths* of the breadth; at 40 degrees *four-tenths* of the breadth. These values may not apply exactly to rudders, owing to the variations in the directions and velocities of the streams impinging upon the surface; but they may be treated as approximately correct.

M. Joëssel was led from his experiments to a very simple law, which confirms previous practice: viz., that for a rectangular plane hinged at its fore edge, and inclined at an angle a to the line of motion, the moment of the normal pressure about the axis, divided by $\sin a$ is a constant. Using the notation of Fig. 132, this law is as follows—

$$P \times AC = \text{constant} \times \sin a.$$

The constant in this expression is simply the moment of the normal pressure when the plane advances at right angles to itself, which moment can be found by the rules already given. If this law be accepted, the estimate for the force required at the tiller-end at any angle a can be very readily made. In a balanced rudder of the usual proportions about one-third of the total area is placed before the axis; as it is desired to give the rudder the power of “righting” itself rapidly when the strain on the steering ropes is relieved. But the distance of the centre of pressure abaft the axis is small, even at the larger angles, and for angles below 10 or 15 degrees the centre of pressure is probably a little before the axis. Hence it happens that with such a rudder, properly balanced, a small force applied at the tiller-end suffices to hold the rudder steady; whereas, in an ordinary rudder having an equal area and held at an equal angle, the force at the tiller-end has to balance the very considerable moment of the pressure about the axis.

M. Joëssel some years ago proposed a special form of balanced rudder designed to still further diminish the force required at the tiller-end when dealing with large areas and considerable helm-angles. Instead of being formed in one solid blade, it consists of two or three blades set parallel to one another and turning about one axis. The distance between the blades is made considerable in relation to their fore and aft measurement, so that the streams of water can pass freely between them and operate upon the surface of each blade. Very extensive experiments have been made with these rudders in the French navy and a few trials have been made in the Royal Navy. They are reported to have fulfilled the expectations of M. Joëssel, and to have enabled very large effective rudder-pressures to be obtained with moderate power

at the steering wheel. From the particulars which M. Joëssel has himself furnished to the Author and from official reports of the trials of French ships, it is evident that with these two or three-bladed rudders and a given power at the wheels, French war-ships have been turned much more quickly and in less space than with ordinary rudders. In one example with 35 degrees of helm, a vessel fitted with an ordinary rudder turned in a circle of 340 metres diameter, occupying $6\frac{2}{3}$ minutes in the manœuvre; whereas with equal helm and the same number of revolutions of the screw, a two-bladed rudder enabled her to complete a circle of 270 metres diameter in $5\frac{2}{3}$ minutes. It does not appear, however, that the double or triple-bladed rudders are greatly superior in steering effect to single-bladed balanced rudders. For instance, in two French armoured corvettes of the same class, one had the usual form of balanced rudder, the other a triple Joëssel rudder of about 75 per cent. greater area. Under nearly identical conditions of speed and helm-angle the first turned in a circle of which the diameter was about 5.7 times her length, and the other, with the triple rudder, turned in a circle of which the diameter was about five times the length. In some English ships with simple balanced rudders the corresponding ratios have been quite as low as any obtained with the Joëssel rudder. The advantage in point of steering of the Joëssel rudder is obtained at the expense of a greater weight; but this is not important. It is also stated that there is a sensible loss of speed, especially in high-speed ships when multiple-bladed rudders are used; and in recent French ships, supplied with steam steering gear, this form of rudder does not appear to have been fitted. Larger rudders can of course be worked with these appliances, and economy of power at the steering wheel becomes less important; so that the Joëssel principle loses much of its value. Its ingenuity remains.

The *work* to be done in putting a rudder over to any angle includes that required to overcome the moment of the pressure about the axis, and that needed to overcome the frictional and other resistances of pintles, bearings and steering gear proper. There may, of course, be a considerable amount of waste-work between the steering wheels and the tiller-end, through friction of wheels, rods, chains, blocks, &c.; but with these we are not now concerned. The *useful work* done in putting the rudder over is that spent in overcoming the moment of the effective pressure on the rudder at each instant as it moves from amidships to the extreme angle (see the parallel case on page 144). For a balanced rudder

this useful work is very trifling. For an ordinary rudder it may be represented approximately by the expression—

$$\text{Useful work} = \text{Constant} \times \text{vers. } a.$$

where a is the extreme angle reached, and the “constant” equals the product of the pressure on the rudder when moved normally to itself at the given speed by half the mean breadth of the rudder. As an example, suppose it was desired to put over an ordinary rudder, having an area of 180 square feet, and a mean breadth of 7 feet, to an angle of 45 degrees, the ship having a single screw, for which the speed is 25 feet per second (about 15 knots); neglecting the obliquity and varying speeds of the streams in the screw-race, and supposing them all to flow fore and aft at a speed of 25 feet per second, the following expressions hold:—

$$\begin{aligned} \text{Normal pressure on rudder} &= \overset{\text{lbs.}}{1 \cdot 12} \times \overset{\text{sq. ft.}}{180} \times \overset{\text{lbs.}}{(25)^2} = 126,000; \\ \text{Useful work} &= \text{Normal pressure} \times \text{Half mean breadth} \times \text{vers. } 45^\circ \\ &= 126,000 \text{ lbs.} \times 3\frac{1}{2} \text{ feet} \times (1 - \frac{1}{2}\sqrt{2}) \\ &= 129,000 \text{ foot-pounds (nearly).} \end{aligned}$$

If steam steering gear were applied, and 12 seconds were named as the time for putting the helm hard over, the nett horse-power of the steering engine would be given by the expression:

$$\text{Nett horse-power} = \frac{129,000}{550 \times 12} = 20 \text{ (roughly).}$$

The actual indicated horse-power of the engine would, of course, be much greater in order to allow for its own waste-work, friction of steering gear, rudder, &c.

When manual power alone is available for steering, balanced rudders have the great advantage of enabling large areas to be put over rapidly to considerable angles; and it was this superiority over ordinary rudders which led to their general use in the larger ships of the Royal Navy between 1863 and 1868.

The balanced type of rudder has been long known. Earl Stanhope proposed it in 1790; it was fitted to a ship by Captain Shuldham about thirty years later, and adopted in the *Great Britain* about 1845. It was not introduced into the Royal Navy until 1863, when the steering gear in use, worked by manual power, had failed to give satisfaction in the long swift ships of the *Warrior* class, and in many other screw-steamers of less size. The extreme angles of helm that could be reached did not

exceed 18 to 25 degrees; and to secure even these results there was such a multiplication of tackles between the steering wheels and tillers as made the loss of power in friction very considerable, and the time of putting the helm over very long. On one occasion, for example, the *Black Prince* was turned in a circle with her rudder 30 degrees from the keel-line; to put the helm over occupied $1\frac{1}{2}$ minute, to complete the circle $8\frac{1}{2}$ minutes were taken, and forty men were engaged at the steering wheels and relieving tackles. On another trial, the *Minotaur*, with eighteen men at the wheels and sixty at the relieving tackles, turned a circle in about $7\frac{2}{3}$ minutes, $1\frac{1}{2}$ minute being occupied in putting the helm over to the very moderate angle of 23 degrees. Balanced rudders enabled both these faults to be corrected, the helm being put up to angles of 35 degrees or 40 degrees very quickly, by the application of a very moderate force at the steering wheels. The *Bellerophon* was the first ship fitted on this principle; and on trial her rudder, which had an area about 25 per cent. greater than that of the *Minotaur*, was put over to an angle of 37 degrees in about 20 seconds by eight men, when the ship was steaming nearly at the same speed as the *Minotaur* had attained. The *Hercules* also, steaming at a higher speed than the *Minotaur*, had her larger rudder put over to 40 degrees in 32 seconds by sixteen men at the steering wheels, and completed a circle in 4 minutes. Further examples of the economy of power and rapidity of motion rendered possible by the balanced rudder will be found in the records of trials of her Majesty's ships.*

Various proposals were made about the same time as balanced rudders came into use, to reduce the work necessary to put ordinary rudders hard over. Mr. Ruthven, known chiefly for his advocacy of the jet-propeller, devised a very clever system of counterbalancing ordinary rudders by means of weights fitted within the ship; but we are not aware that the plan has ever been adopted. There are obvious objections to the additional weights and complication involved in such an arrangement; especially if applied to rudders of as large area as can be conveniently dealt with on the balanced system.

The introduction of steam and hydraulic steering apparatus has, however, restored the use of ordinary rudders in the largest screw-steamers of the Royal Navy. In vessels possessing sail-power as well as steam-power, it has been found that the balanced

* See a valuable Paper by Mr. Barnaby in the *Transactions* of the Institution of Naval Architects for 1863.

rudder, with its large area and facility of movement, might, unless carefully managed, cause ships to miss stays, or to fail in manœuvring under sail alone. The compound balanced rudder was devised to remove this objection, and has answered its intended purpose; but it is costly. Moreover, in all ships it is admitted that the ordinary rudder is less liable to serious damage, by striking the ground or other accidents, than the balanced rudder. When efficient apparatus had been devised by which the rudders of the largest vessels could be brought under the control of one man, and put over rapidly to any angle desired, there was every reason, therefore, to resume the use of ordinary rudders. And with twin-screw propellers these rudders possessed further advantages over the balanced type, in enabling the power of the screw-race on either side to be utilised more efficiently. One example will suffice of the great advantages gained by using steam steering engines in large ships. The *Minotaur* is now fitted on this principle, and on trial it was found that the rudder could be put over to 35 degrees in about 16 seconds by two men; the circle was turned in about 5½ minutes, and its diameter was less than two-thirds as great as that on the former trial. Placing these figures beside those stated above, when manual power alone was used at the steering wheels, it will be seen how great has been the improvement made in this ship, of which the rudder remains unaltered; and comparing the helm-angle and time for putting the rudder over with the figures given for ships with balanced rudders, it will be seen that the ordinary rudder with steam steering is at no disadvantage.

In ships of war, steam steering gear has the further advantage of placing the control of the largest ships in the hands of one or two men, possibly in those of the commanding officer himself. To secure this advantage, such gear has been fitted in ships with balanced rudders, where the gain in manœuvring power has been comparatively small. Large merchant steamers are similarly fitted, the *Great Eastern* having been one of the first vessels furnished with a steering engine. A small auxiliary engine is now usually employed for the purpose, steam having been generally preferred to hydraulic power after numerous trials, although some arrangements on the hydraulic principle have given great satisfaction. Plans have been devised for taking power off the main screw-shafts in order to steer ships, but they have not found much favour; and the arrangements now in use having proved thoroughly satisfactory, it is unlikely that the power of the main engines will be utilised for steering. The

great majority of ships are still steered by manual power, and are likely to continue in that condition, their moderate sizes and speeds enabling ordinary appliances to put their helms over quickly to sufficiently large angles.

Thirdly: as to the effect of the rudder in turning a ship. This is the purpose for which the rudder is fitted, but the preceding remarks have been necessary in order to clear the way for the description that will now be attempted.

Suppose a ship to be advancing on a straight course and with uniform speed, the stream-line motions on either side being perfectly symmetrical; then it is known, as the result of model experiments, that the least disturbing cause will produce a departure from this balance of the stream-line motions, and cause the vessel to swerve from her original course. Immediately after the helm begins to move over, such a disturbing cause is developed in

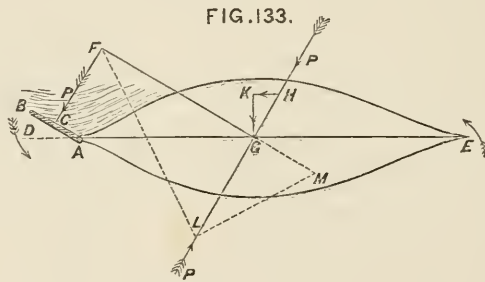

the pressure on the rudder, the magnitude of which increases as the helm-angle becomes larger. Fig. 133 shows the plan of a ship, with the rudder (AB) put over to the angle BAD; the arrow indicates the line of action of the resultant pressure P. Let G indicate a vertical axis passing through the centre of gravity of the ship; through G draw the line HL parallel to the line of action FC of the resultant pressure on the rudder, and along HL suppose two equal and opposite forces P, P to be applied. These forces will balance one another, and therefore will not produce any change in the conditions to which the ship is subjected independently of them. By this means the single force P on the rudder is replaced by a single force P acting along HG, and a couple formed by the pressure P on the rudder and an equal force acting along LG; the arm of this couple is GF, and it evidently tends to turn the vessel in the direction indicated by the arrows at the bow and stern. The single force P acting along HG tends to produce a simultaneous motion of translation

of the vessel along its line of action. This force P may be resolved into two components: if GH represents P , HK will be its component acting parallel to the keel, and KG the component acting perpendicularly to the keel. The transverse component is usually larger than the longitudinal; but it is not so important because at each instant it has opposed to it the great force of *lateral resistance*,* and therefore can cause but a very small speed of drift. The longitudinal component, on the contrary, may exercise a sensible effect in checking the speed of a ship while she is turning. As the rudder is put over, the value as well as the direction of P change, and the absolute and relative values of these component forces will change; but at each instant conditions similar to those described will be in operation. It becomes important, therefore, to trace the consequent motion of the ship; and for the sake of simplicity it will be assumed that she is a steamer, the propelling force being delivered parallel to the keel-line.

Ultimately, when the rudder has been held at a steady angle for some time, the ship will be found to be turning in a path which would be very nearly a circle, and is usually treated as if it were a circle. Her speed will be less than it would be if she were steaming on a straight course with the same engine-power, and her ends will be turning about the vertical axis passing through the centre of gravity, with a nearly uniform motion, or angular velocity. Before this condition could have been reached, however, there must have been a period during which the angular velocity was gradually accelerated up to its uniform value, while the headway was being checked, and before the drift to leeward had supplied a resistance balancing the component of the rudder pressure and the centrifugal force. It will be well, therefore, to glance at this period of change before considering the case of uniform motion.

As soon as the rudder is put over, an unbalanced couple will be brought into operation, and the ship will begin to acquire angular velocity. At first this velocity will be very small; and as the resistance offered by the water to rotation varies very nearly as the *square* of the angular velocity,† that resistance is of little importance in the earliest stages of the motion. The initial

* See page 488.

† The analyses which we have made from numerous turning trials of the *Warrior* enables us to state that in her case the resistance varies with a power

of the angular velocity almost identical with that deduced from the experiments made by Mr. Froude on frictional resistance.

values of the angular acceleration will therefore chiefly depend upon the ratio which the moment of the couple bears to the moment of inertia of the ship about a vertical axis passing through the centre of gravity (G , in Fig. 133). That moment of inertia is determined by multiplying the weight of every part of the ship by the square of its distance from the axis of rotation; and the moment of inertia would evidently be much increased if heavy weights were carried near the extremities instead of being concentrated amidships. Hence, with a certain rudder area put over to the same angle in the same time, in two ships similar to another in outside form and immersion, but differing in their moments of inertia, the ship having the less moment of inertia will acquire angular velocity more quickly than her rival. Moreover, it will be evident that a ship of which the rudder can be put over quickly to its extreme angle will acquire angular velocity more rapidly than she would with the same rudder put over slowly. As the angular velocity is accelerated, the moment of the resistance increases, exercising an appreciable effect upon the acceleration; and finally a rate of motion is reached for which the moment of the resistance balances the moment of the couple due to the corresponding pressure on the rudder, the angular velocity then becoming constant.* It will, of course, be understood that, simultaneously with this acquisition of angular velocity, a retardation of headway will have taken place, and carried with it some change in the pressure on the rudder, which will also be affected by the considerations mentioned on page 626; the balance between the lateral resistance and the other forces named above will also have been established.

Four features, therefore, chiefly affect the readiness of a ship to *answer her helm*: (1) the time occupied in putting the helm hard over; (2) the rudder pressure corresponding to that position; (3) the moment of inertia of the ship about the vertical axis passing through the centre of gravity; (4) the moment of the resistance to rotation. Only the first and second of these can be much influenced by the naval architect; their importance has already been illustrated from the turning trials of the *Minotaur*. The moment of inertia is principally governed by the longitudinal distribution of the weights in the ship; in arranging these weights, considerations of trim, convenience, and accommodation are paramount. The moment of resistance depends upon the

* See the similar case previously illustrated for the effect of resistance to the oscillations of ships among waves; page 237.

form and size of the immersed part of the hull; and is especially influenced by the fine parts of the extremities. In some ships the deadwood forward and aft has been cut away considerably, in order to increase the handiness; but this practice is not common, and for sea-going and sailing ships it is open to the objection that it diminishes the lateral resistance and the resistance to rolling. Hence it rarely happens that a designer endeavours to exercise much control over the resistance to rotation; but in torpedo vessels, yachts and small craft the attempt is sometimes made.

Closely associated with this readiness to answer the helm, or to acquire angular velocity, are the conditions which control the decrease of that velocity when a vessel has had her head brought round to a new course upon which it is desired to keep her. The greater the ratio of the moment of resistance to the moment of inertia, the more rapid will be the rate of extinction of the rotation; and, conversely, the greater the ratio of the moment of inertia to the moment of resistance, the slower will be the rate of extinction. Both moment of inertia and moment of resistance must be considered; and possibly the helm would be brought into action to assist in keeping the ship on her new course. Deep draught, considerable length, fine entrance and run, deep keels and other features which lead to an increased resistance to rotation, are not, therefore, altogether disadvantageous. They make a vessel slower in acquiring angular velocity, but they enable her to be kept well under control. Shallow-draught vessels are not unfrequently less manageable by the helm than deep-draught vessels; they quickly acquire angular velocity, and turn rapidly, but have comparatively small resistance in proportion to the moment of inertia, and are not easily kept on a new course, "steering wildly" in some cases, as a sailor would say. In such cases the addition of a deep keel and consequent increase of resistance to rotation and drift often greatly improves the steerage. Vessels of the circular form possess great moment of inertia, whereas nearly the whole resistance to rotation must be due to skin friction, and can be but of moderate amount. It might, therefore, be expected that these vessels would be difficult to check and keep on any desired course if they had been turned through a considerable angle and acquired a good angular velocity. It has, in fact, been asserted that the vessels are "ungovernable" under the action of their rudders; and their designer, Admiral Popoff, in replying to these criticisms, dwelt upon the manœuvring power obtained by the unusual number of

their propellers, not claiming for them great handiness under the action of the rudders alone.*

Experienced seamen declare that, when a steamer has headway, and the helm is put over, "the head appears to turn" comparatively slowly while the stern swerves suddenly to "the right or the left."† This is quite in accordance with theoretical considerations. Professor Rankine many years ago published an investigation for the instantaneous axis about which a ship should begin to turn when the rudder was first put over, on the supposition that the first action of the rudder might be regarded as an *impulse*. His construction for this instantaneous axis is shown in Fig. 133. The length GL represents the "radius of gyration" of the ship about the vertical axis passing through the centre of gravity G; and is measured on the line HL drawn perpendicular to the arm FG of the couple.‡ Join FL, and produce FG to M; draw ML perpendicular to FL, meeting FM in the point M; that point will be the "instantaneous axis" about which the *first* movement of the ship takes place, and M may lie considerably before the centre of gravity. To determine the instantaneous motion of any point in the ship, it is only necessary to join that point with M, and to describe a small circular arc with M as centre. It will be understood that this construction only applies to the motion of the ship at the *first moment* after the rudder is put over.

Purely theoretical investigation does not enable one to lay down the path traversed by the centre of gravity of a ship in turning from a straight course under the action of her rudder. The equations of motion can be framed in general terms; but our knowledge respecting the resistance offered by the water to the motion of the ship is not sufficient to enable all the quantities to be expressed, and a complete solution reached. Hence it becomes necessary that the problem should be attacked by actual experiment, and that careful observations should be made of successive positions occupied by a ship so that the path traversed might be subsequently plotted. In such determinations of the path of a ship it is convenient (1) to take the original straight course as the *line of reference*, from which to measure the angles turned through by the keel-line of the ship in specified times;

* See a lecture delivered at Nicolaieff in 1875, of which a translation appeared in *Naval Science*.

† See an interesting article, "On

Sternway," by Captain Allen, R.N., in *Naval Science* for 1875.

‡ See page 136 for an explanation of the term "radius of gyration."

(2) to take as an *origin of co-ordinates* the position of the centre of gravity of the ship on her straight course at the instant when the helm begins to move over; (3) to note the path of the centre of gravity while the ship turns. This centre in most ships is situated very near the middle of the length; so that the path of the latter point will serve for all practical purposes, as the path of the centre of gravity. With these means of reference, if the place of the centre of gravity is fixed at frequent intervals of time, a curve can be drawn through the points thus obtained, and will be the path required. If simultaneous observations are made of the angles through which the head of the ship has turned from her original course, the instantaneous positions of the keel-line are known for a series of positions, and its instantaneous inclination to the corresponding tangents to the path of the centre of gravity can be ascertained.

Until questions of steam tactics for war-ships became important, and the employment of ships as rams occupied attention, no attempts appear to have been made to determine accurately the path traversed. In recent years, however, many such observations have been made both in the Royal Navy and in foreign navies; their great practical value is now generally recognised, and additions are rapidly being made to our knowledge.

The French experimental squadrons of 1864–66 were subjected to very exhaustive turning trials, and the observations made would have sufficed to determine the complete motions of the ships from their straight course; but this was not done, attention being chiefly devoted to the determination of the circular paths in which each ship turned after her motion had become uniform.* Since then it has been recognised that for tactical purposes it was more important to know what was the nature of the path traversed immediately after the helm was put over, and where the ship would be placed when she had turned through the first 90 degrees, as well as her position when she had turned through 180 degrees and reversed her course.

One of the earliest proposals for determining accurately the motion of a ship in turning was made by M. Risbec of the French navy, and applied by him to a small vessel, the *Elorn*, at Brest, in November, 1875.* This method is, we believe, still generally used in the French navy, and is exceedingly well adapted for its purpose.† In its main features it resembles

* See *Méthodes de Navigation*, &c., by Admiral Bourgois. Paris: Arthur Bertrand.

† See vol. xlix. of the *Revue Maritime* for further particulars.

methods of observation previously known, and occasionally applied, and a brief account of it may be of interest. Two observers are stationed at a considerable distance apart on a line parallel to the keel-line of the ship, as indicated by the points A and B, Fig. 133*a*. They are each furnished with a simple sighting instrument (or azimuth instrument), and at frequent intervals of time, at a given signal, observe simultaneously, and record the angles α and β made with the line AB by their respective lines of sight to a floating object, O, placed within the path traversed by the vessel. This object may be anchored if there is no tide or current, but otherwise may be a simple buoy or boat with a flag-staff. A large number of observations being made, a series of triangles, such as AOB, can be constructed, the length AB being constant, and the errors of observation can be

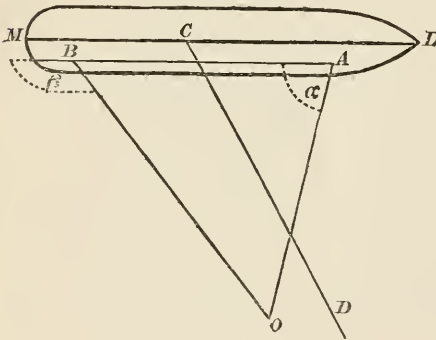
FIG 133 α 

eliminated by a careful comparison and analysis of the results. To complete the plotting of the path of the ship, it is necessary to fix the position of any such triangle as AOB; this is done by a third observer, C, who notes and records the bearings of a fixed and distant object, with reference to the keel-line, each time that the signal

is given for the first two observers to note the bearing of O from their stations. The angle LCD is that which he has to determine in each case, and this may be done in other ways than that named above.

Another very excellent series of trials was made on the *Thunderer* at Portland in 1877. The details of the observations and their principal results will be found in the Appendix to the Report of the *Inflexible* Committee. In some respects these trials were more exhaustive than any previously made, and the utmost care was taken to check the several observations and eliminate errors. They well deserve the study of all who are interested in the turning trials of ships. Fig. 133*b* shows the path of the ship when turning from a straight course *L* on which her speed was nearly $10\frac{1}{2}$ knots, and it may be well to look a little more closely into the facts ascertained for the *Thunderer*, as they are doubtless

fairly representative for war-ships of her class, and indicate what must happen in all ships when turning.

The path of the ship when she begins to turn away from her straight course will be seen to be spiral, and not circular; consequently when she has turned through 360 degrees she is found (at E) somewhat within the line AC of her original course. As she acquires angular velocity, so her bow turns *inwards* from the

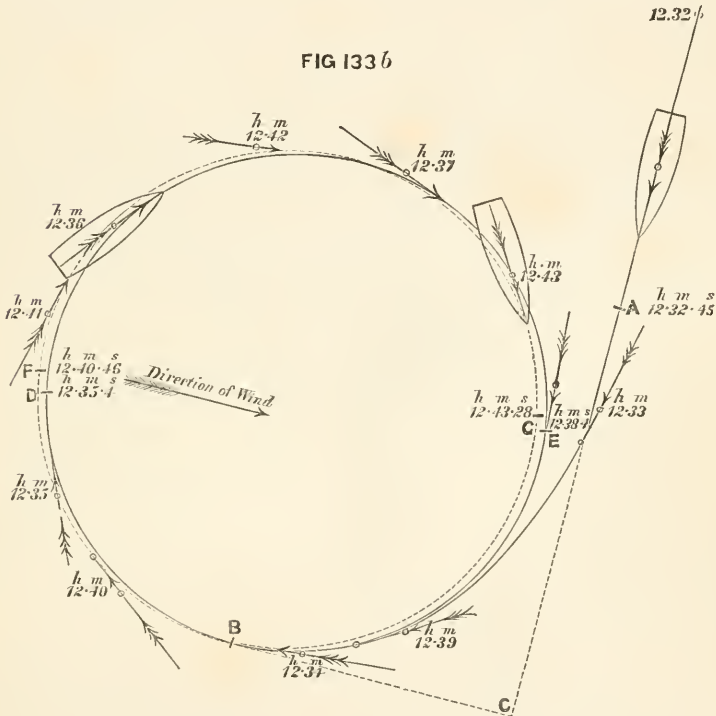

References.

- AC, original straight course of ship.
- A, her position when helm begins to move over.
- B, " " " " she has turned 90°.
- D, " " " " " " 180°.
- E, " " " " " " 360°.
- F, " " " " " " 540°.
- G, " " " " " " 720°.

tangent to the path of her centre of gravity, and the angle between this tangent and the keel-line, or "drift-angle," (*angle de dérive*) as it is termed, gradually increases. Owing to the existence of this drift-angle the thrust of the propellers, when a ship

is turning, is delivered at each instant athwart her course; and to this must be mainly attributed the loss of speed which takes place, and which is commonly attributed to the "drag" of the rudder. Her angular velocity meanwhile undergoes rapid acceleration, and as she turns centrifugal force comes into operation, and the ship heels from the upright. By degrees these transitory conditions give place to uniform conditions, if the helm is kept at a constant angle and the engines at a nearly constant speed; and ultimately the ship moves in a practically circular path, with a constant drift-angle, and a steady angle of heel. The time occupied in attaining this state of uniform motion varies in different ships; the time occupied in putting the helm hard over must largely influence the time occupied in acquiring uniform angular velocity, and other considerations must affect the periods occupied by different ships in passing through the various changes sketched above. In the following table appears a summary of facts for the earlier portions of the turning of the *Thunderer* which will render further explanation unnecessary:—

TURNING TRIALS OF *Thunderer*.

	Time.	At end of time.	
		Speed of ship.	Angular velocity per second.
	Seconds.	Knots.	
To put helm over 31°	19	10·4	0° 20'
To turn ship's head 45°	56	9·25	1 18
" " 90	89	8·3	1 18
" " 135	123	7·75	1 15
" " 180	159	7·5	1 12
" " 360	320	7·14	1 6 $\frac{3}{4}$

At 360 degrees the turning motion had become practically uniform. It appears that with steam steering gear similar conditions of uniform motion are usually reached as soon as, or sooner than, they were reached in the *Thunderer*. With manual power only similar conditions are sometimes not reached until a vessel has made two or more circuits. When a ship has turned through 90 degrees her motion will not be uniform and her path is still spiral. Hence it is desirable that a commanding officer of a war-ship should determine by actual observation, at different speeds and with different helm-angles, how the ship would be placed, in relation to her course and position at the instant when the helm was put

down, after she has turned through 90 degrees. We shall revert to this subject hereafter.

We must now pass to the consideration of the motion of a ship in still water, after it has become *uniform*. The centre of gravity of the ship will then be moving in a circular path, and all other points in her will be moving in concentric paths. The fore end of keel-line of the ship will be turned within the tangent to the path of the centre of gravity, making a drift-angle with it of greater or less amount. In Fig. 133*c*, O represents the centre of the circle; G_1GG_2 the path of the centre of gravity; G the instantaneous position of that point, and TGT_1 the tangent at G; AB is the keel-line; BGT_1 is the drift-angle for G. From O a perpendicular OP is let fall on AB. Then the tangent to the

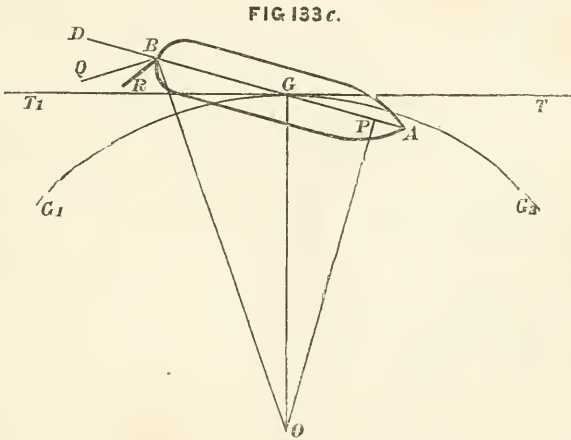

circular path described by the point P coincides with the keel-line; consequently there is no drift-angle at P, and it is sometimes termed the "pivoting point," because, to an observer on board, the ship seems to be turning about it (see also remarks on page 618). It will be understood, of course, that O is the true centre of motion for the ship in turning. In the *Thunderer* the pivoting point P varied from 67 to 103 feet before the centre of gravity, or from 80 to 40 feet abaft the bow. As the speed and drift-angle increased, the point P moved forward. Cases may occur where the drift-angle at the centre of gravity is so considerable that the pivoting point lies before the bow, and is found on the keel-line produced. By means of a construction similar to that shown for the centre of gravity G the drift-angle can be determined for any other point on the keel-line. Take, for

example, the extreme after-end B: join OB, draw QB perpendicular to OB, and the angle DBQ is the drift-angle at B. The angle DBQ is greater than the drift-angle BGT, for the centre of gravity; and it will be obvious that, for all points lying between B and the pivoting point P, the drift-angle will remain of the *same sign*, but decrease in value as the distance of the point under consideration from P diminishes. At P the drift-angle has a zero value, in passing through which it changes sign, and for all points lying before P the drift-angles have *negative* values, as compared with the angle BGT. That is to say, if a point such as A is taken, lying on the fore side of P, and OA is joined, the line drawn through A perpendicularly to OA, representing the tangent to the circular path of the point A, will lie on the other side of the keel-line AB, from that on which the tangent GT₁ is situated.

The value of the drift-angle measured at the centre of gravity, varies in different vessels, and also varies in the same vessel under different conditions of speed and helm-angle. In the *Thunderer* experiments with a constant helm-angle, and practically a constant time for putting the helm hard over, the drift-angle varied from $5\frac{3}{4}$ degrees at 8 knots to $9\frac{1}{2}$ degrees at 11 knots. In the *Iris*, under similar conditions, the variation in drift-angle was only from $6\frac{1}{2}$ degrees at 9 knots to 7 degrees at $16\frac{1}{2}$ knots. In some of the experiments made with French ships, drift-angles from 16 degrees to 18 degrees have been reached. Further experiments are needed in order to determine the law of variation, but so far as can be seen at present, the drift-angle becomes greater as the area of rudder and the angle of helm (up to 45 degrees) are increased, speed being constant; and also sometimes increases with increase in speed, other things remaining the same.

As a consequence of the drift-angle, the bow and stern of a ship revolve in circles of different diameters when the motion has become uniform. In the *Thunderer* this difference varied from 60 to 100 feet on a mean diameter of 1300 feet, the stern, of course, moving in the larger circle. In the French ironclad *Solferino*, the diameter of the circle swept by the stern exceeded that swept by the bow as much as 40 metres on 900 metres. The larger the drift-angle the greater is this difference.

Another consequence of the drift-angle, to which allusion has already been made, is the reduction in speed sustained by a ship in turning. In several cases where the loss of speed has been accurately measured, it has been found to reach *two-tenths* to

three-tenths of the speed on the straight course before the helm was put over. In experimental trials with small vessels, fitted with rudders of very large proportionate area, the loss of speed has been much greater, amounting it is said to 40 or 50 per cent. of the speed on the straight. In the *Delight* gunboat, Admiral Sir Cooper Key ascertained that when the balanced rudder was very large and it was put over to 40 or 45 degrees, the first quadrant was turned through in about 31 seconds, and the diameter of the circle was 205 feet, or only twice the length of the vessel; but the loss of speed was so considerable, due to the large drift-angle and the drag of the large rudder, that the whole circle took two minutes forty-six seconds to perform. With an ordinary rudder of small area put over to equal angles, and about the same speed on a straight course, the first quadrant took $33\frac{1}{3}$ seconds. The diameter of the circle was 225 feet, and yet the loss of speed was so much less in turning that the whole of the larger circle was completed in two minutes thirty-eight seconds. This example illustrates a well-known fact in screw-ship steerage; viz., that a very large rudder-area will increase the drift-angle, and diminish the time during which the angular velocity is becoming uniform, as well as the space required for turning, but may lengthen the time. The case somewhat resembles in character that described for twin-screws on page 654.

On consideration of the facts above stated it will be seen that the motion of a ship in turning resembles that of a ship sailing on a wind, except that in the latter case the path of the centre of gravity is straight instead of being curved. At each instant the vessel moves obliquely to her keel-line.

To the "angle of leeway" in the sailing ships (see page 488) the "drift-angle" of the ship which is turning may be considered to correspond: but whereas in the first case all points in the ship are moving in parallel lines, and the angle of leeway has a constant value; in the second case (as explained above) the drift-angles for different points have different values, or possibly different signs. This variation in the drift-angle complicates the problem, rendering difficult any general statement of the conditions which govern the flow of water relatively to different parts of the immersed surface of a ship which is turning, or the distribution of the fluid pressures. There can, of course, be no question but that, on the side of the ship most distant from the centre of her path, there will be an excess of pressure, usually styled the force of lateral resistance (see page 615). Nor can it be doubted that cases occur, wherein the pivoting point P lies

before the bow, and there is a considerable accumulation of pressure on the outer or lee-bow, which pressure not merely checks the speed, but assists the rudder in turning the ship. If the pivot point P lies (as in Fig. 133e) between the bow and the middle of the length—as it very frequently does—the case is less simple. For points on the keel-line abaft P, there are positive drift-angles; and if small “drop-rudders,” hinged at their fore ends, were let down below the keel and left free, they would probably find their positions of rest at some angle of inclination to the starboard side of the keel-line AB. BQ in Fig. 133e may be taken as an indication of the position of rest for one such rudder. For points on the keel before P the positions are reversed: similar drop-rudders placed at any of these points would find their position of rest at some inclination to the port side of AB. These rudder-indications simply show that, in the case of which Fig. 133e is an illustration, the flow of water for points abaft P is inwards, and that there is an excess of pressure on the outer side; whereas for points before P the flow is cutwards, and the excess of pressure is on the inner side of the bow. The last-mentioned excess clearly acts against the rudder; whereas the excess on the outer side probably assists the rudder, and in many cases may be supposed to more than counterbalance the pressure on the inner bow. It will be seen therefore that an increase in the drift-angle, and consequent movement of the pivot point towards the bow, is likely to be accompanied by an increase in the turning power of a ship.

It must be noticed here also that the same circumstances sensibly affect the flow of the water at the stern, even of screw steamers, and reduce the effective helm-angle (see remarks on page 600). Turning to Fig. 133e, let BR represent the rudder, and BD the middle line of the ship produced. Then RBD represents the angle made by the rudder with the keel, and for motion on a straight course this would be taken as the *effective* helm-angle. For a ship turning rapidly, however, the angular motion of the stern causes the flow of water to take place very differently; and, if for an instant the helm were left free, while the angular motion of the ship continued, it would find its position of rest (or zero-pressure) at some line, such as BQ, Fig. 133e, inclined more or less to the keel-line. The ordinary assumption is that, if OB is joined and BQ drawn perpendicular to it, BQ will be approximately the position of rest; and it has been shown that the angle DBQ is the drift-angle for B. On this assumption, therefore, the effective helm-angle is the difference between the angle made with the keel-line by the rudder and the drift-angle at the stern. This

reduction may be very considerable, amounting to one-half of the apparent helm-angle. French experimentalists have endeavoured to determine the reduction exactly in some cases, and assert that it commonly reaches one-half of the apparent helm-angle; therefore practically reducing the turning effect of the rudder by nearly one-half, as compared with what the same angle of rudder with the keel would give at the first instant the helm is hard over, and before a ship has acquired much angular velocity. Further observations are needed, however, in order to decide this matter; but it is evident that, in ships where the greatest angle of helm with the keel-line cannot be made to exceed 30 degrees a reduction of 10 or 15 degrees involves a very serious loss of efficiency.

Supposing the effective helm-angle and the corresponding normal pressure on the rudder to have been determined, then, when the turning motion of a steamship has become uniform, the forces acting upon her would be as follows: (1) the propelling force delivered parallel to the line of keel; (2) the pressure delivered perpendicularly to the surface of the rudder; (3) the centrifugal force acting at each instant along the radius of the circular path traversed by the centre of gravity; (4) the resistance of the water to the motion of the ship. Of these the first and third, acting through the vertical axis passing through the centre of gravity of the ship, do not tend to produce rotation about that axis. The pressure on the rudder and the lateral resistance, each exercise a powerful turning moment, and the sum of these moments must be balanced by the moment of the resistance to rotation. But while these general considerations may be stated, it is not possible, at present, to express definitely the values of either the moments of the lateral resistance or the resistance to rotation.

In concluding these remarks on uniform angular motion, it may be well to refer to the *heeling* which accompanies turning. The forces which tend to produce heeling are as follow:—

1. The centrifugal force acting outwards through the centre of gravity of the ship, and tending to make her heel away from the centre of the circle.

2. The lateral component of the rudder-pressure, acting through the centre of pressure of the rudder and usually at some depth below the centre of gravity of the ship, tending to make her heel inwards towards the centre of the circle.

3. The lateral component of the fluid resistance on the outer side of the ship, which equals in magnitude the resultant of the centrifugal force and the rudder-pressure, and acts through the centre of lateral resistance.

Fig. 133*d* shows the distribution of these forces in the *Thunderer*, determined from the turning trials made at Portland. Here again it is common to find the rudder-pressure credited with

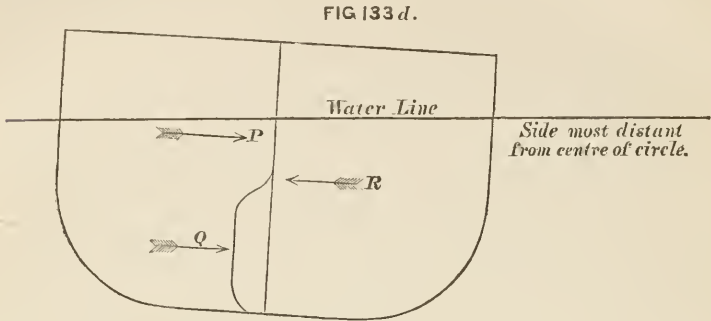

the heeling effect; whereas it may, in most cases, be neglected in comparison with the centrifugal force. A fair approximation to the angle of heel for a ship in turning is given by the following equation:—

$$\sin \theta = \frac{1}{32} \times \frac{d}{m} \times \frac{v^2}{R},$$

where θ = angle of heel,

v = speed of ship in feet per second,

R = radius of circle turned (in feet),

m = "metacentric height;" the height of transverse metacentre above centre of gravity,

d = distance of centre of gravity above centre of lateral resistance.

This expression for $\sin \theta$ should strictly be multiplied by $\cos \phi$, where ϕ is the drift-angle for the centre of gravity; but this correction may be neglected if ϕ falls below 10 degrees, as it frequently does.

In the *Thunderer*, the centre of lateral resistance was found to be from .43 to .49 of the mean draught below the water-line; probably a fair approximation for war-ships of ordinary form would be from .45 to .5 of the mean draught. From the foregoing equation it will be seen that—

- The angle of heel varies
- (1) Directly as the *square of the speed* of ship;
 - (2) Inversely with the *metacentric height*;
 - (3) Inversely with the *radius of the circle*.

Hence it is obvious that ships of high speed, fitted with steam steering gear, capable of turning in circles of comparatively small diameter, are those in which heeling may be expected to be greatest. Moderate values of the metacentric height further tend to increase the heeling. If the speed be *doubled*, the angle of heel will be about *quadrupled*, if the radius of the circle turned and the metacentric heights remain constant. In order to maintain a certain angle of heel under these altered conditions of speed, the metacentric height would also have to be quadrupled; but such an increase in stiffness is clearly undesirable even if it were practicable. The following figures may be interesting:—

	Speed on straight.	Diameter of circle.	Draught.	Metacentric height.	Angle of heel.
	Knots.	Feet.	Feet. ins.	Feet.	° ' /
<i>Thunderer</i>	8·2	1,310	26 3	3·12	0 52
	9·4	1,250	26 1		1 11
	10·4	1,240	26 1		1 14
<i>Tourville</i> (French) . . .	15	2,030	3 30
<i>Victorieuse</i> (French) . .	10	1,290	2 0

It is important to notice that in taking observations of the angle of heel for a ship in turning, allowance must be made for the effect of the centrifugal force upon the indications of pendulums or clinometers. The error of indication is usually in excess, and the correction is very easily made when the diameter of the circle and time of turning have been ascertained.

Although it is the rule in large ships to heel outwards in turning, after a sensible angular velocity has been attained, the first effect of putting a large rudder over quickly may be to cause the ship to heel inwards under the influence of the rudder-pressure, and this heel may be the greater because of the comparatively sudden application of the force (see page 168). This condition was actually illustrated in the *Thunderer*, the initial heeling took place *inwards*; it was of small magnitude and was quickly succeeded by a considerable heel outwards as the ship acquired angular velocity. Cases are also conceivable, and have occurred, where the heeling has taken place inwards throughout the motion. If the circle turned has a very large diameter, if the distance *d* is small (as in light-draught vessels such as torpedo-boats) the inclining moment of the centrifugal force will be small, and the inclination may take place as supposed, especially if the rudder is placed low down. It is also possible, though not likely to

occur in ordinary forms of ships, that the centre of gravity may fall so low down as to be below the centre of lateral resistance; in which case, of course, the inclination would be inwards. If bow-rudders are fitted, their tendency is clearly to make a vessel heel outwards from the centre of the circle.

Besides heeling transversely a ship will also change trim when turning under the action of her rudder. The longitudinal inclinations are, however, so small as to have no practical importance, and frequently they are scarcely appreciable.

For many years past turning trials have been commonly made with new ships of war, both in the Royal Navy and in foreign navies. The primary intention in these preliminary or constructors' trials has been to thoroughly test the efficiency of the rudder and steering gear, a rough idea of the relative handiness of the ships also being obtained. For ships of the Royal Navy these preliminary turning trials are made in smooth water and light winds, with the helm hard over to port or to starboard, the ship running with engines at full or half power. The observations made include—(1) a record of the time occupied in putting the helm over; (2) a record of the times occupied in turning the half circle and full circle respectively; (3) a measurement of the diameters of the "circles" in which the ship turns. In some cases the turning trials are extended to other speeds than those corresponding to full or half power; or to angles of helm varying from "hard over" down to small angles with the keel-line; but these extensions are not common. Additional trials are also made in twin-screw ships, or ships with other kinds of duplicate propellers, to determine their behaviour when one propeller is working ahead and the other astern, or when one propeller only is at work. It need hardly be added, however, that even the fullest constructors' trials do not furnish all, or nearly all, the information respecting the steering qualities of ships which commanding officers require. Continued experience in management, and the further trials which can be made during the service of a ship at sea, enable commanding officers to acquire an intimate knowledge of the turning powers of their ships under various conditions of wind, sea, speed, and helm-angle. The experience thus gained is of the greatest value, not merely as regards the management of individual ships, but in the aggregate it should form the basis of any system of naval tactics. In the Royal Navy the regulations provide for the conduct of such turning trials in all new ships, and for the record of the results in the "Ship's

Books," for the information of officers who may succeed to the command: and in recent years these regulations have been the means of putting on record some of the most detailed and trustworthy *data* relating to screw-ship steering. The interest which is now taken in the subject by naval officers also affords a guarantee of further additions to our knowledge of this important subject. In the French navy great attention is also being bestowed upon the subject, and there, as well as in the Royal Navy, officers are anxious to determine all the phenomena attending the turning of ships, as well as to trace the paths traversed. Limits of space prevent any description here of the methods of observation proposed or adopted in connection with turning trials; for these reference must be made to other publications.* But it may be of service to deduce from the results of these trials a few of the more valuable principles and facts, which they have established:

(1) The path traversed by the centre of gravity of a ship while she turns from a straight course through 180 degrees—that is, reverses her course—is usually more or less spiral, and not a circular arc as Admiral Boutakoff assumed in his *Tactiques Navales*. Allusion has already been made (see page 618) to the principal circumstances which influence the form of this part of the path. For tactical purposes two points on it are of the greatest importance: viz., the position of the ship when she has turned through 90 degrees, and her position when she has reversed her course. The perpendicular distance between this reversed course and the original course is termed the "tactical diameter" (*diamètre d'évolution*). But its determination does not fix the space required for turning; because it leaves unknown the distance which the ship advances parallel to her original course from the instant when her helm is put over to that when her head has swung through 90 degrees. In Fig. 133*b*, for instance, let A be the position of the ship when the helm began to move; B her position when 90 degrees have been turned through. Draw AC as a prolongation of the original straight course, and BC perpendicular to AC; then AC is the distance required, or as it has been termed the "advance" of the ship. This may become very considerable under some circumstances, in proportion to the tactical diameter,

* See various Papers in the *Revue Maritime* from 1877 to 1881. See also a Paper contributed by the Author to the *Journal* of the Royal United

Service Institution for 1879 "On the Turning Powers of Ships," from which Paper many of the facts and illustrations given in the text are reproduced.

or to the simultaneous movement, sometimes termed the "transfer," in a direction at right angles to the original course.* For example in the *Thunderer* the tactical diameter was 1320 feet, the "advance" to the 90 degrees position was 1000 feet, and she was then at 700 feet perpendicular distance from her original course. In the *Iris*, at 10 knots the tactical diameter was 2300 feet, the advance for 90 degrees was about 1470 feet, and she was then 1040 feet distant from her original course. It will be noted that when the head of a ship has swung through 90 degrees, the tangent to the path of the centre of gravity will have only turned through 90 degrees less the drift-angle at that instant, which will have different values in different ships, and under varying circumstances in the same ship. The ratio of the advance to the transfer at the 90 degrees position will also vary greatly in different ships. In shallow-draught vessels, and more especially in those of high speed, such as torpedo-boats, the momentum in the direction of the original course, which the vessels have at the instant when the helms are put down, is not quickly destroyed by the lateral resistance, and they "sheer off" in turning, the advance having a considerable relative value.

(2) After the turning motion of a ship has become uniform the path of her centre of gravity is practically a circle having a diameter somewhat smaller than the tactical diameter. The French use the term *diamètre de giration*, for this circle; *final diameter* has been proposed as the English equivalent. In the *Thunderer* trials, the mean ratio of the final to the tactical diameter was about 100 : 105. In trials with the *Iris*, at speeds from 9 to 14 knots, nearly the same mean ratio held good. In trials with the French armoured corvette *Victorieuse*, the ratio was about 100 : 117.

(3) Most of the turning trials hitherto made on new ships—the constructors' trials, as they have been termed above—may be supposed to give approximations to the *tactical diameters* of the ships. For war-ships, the following results have been obtained.† With manual power and ordinary rudders the diameter of the circle for large ships has been found to vary between six and

* These terms—advance and transfer—were suggested by Captain Colomb, R.N. They express the meaning very simply of measurements which in mathematical language would be styled the "co-ordinates" of the centre of gravity at any time, referred to the axes described on page 618.

† For details see Admiral Boutakoff's *Tactiques Navales*, M. Dislere's *Marine Cuirassée*, Admiral Bourgois' *Études sur les Manœuvres des Combats sur Mer*, M. Lewal's *Principes des Évolutions Navales*, and the Author's Paper "On the Turning Powers of Ships," mentioned on page 631.

eight times the length of the ships. For small ships, wherein manual power suffices to put the helm over rapidly and the speed is low, the diameter falls to three or five times the length. For swift torpedo-boats, with manual power only at the helm and very small angles of helm, the diameter of the circle for full speed has reached about twelve times the length, and for half speed about four or six times the length. With manual power and *balanced* rudders, the diameter for large ships has been reduced to four or five times the length, and nearly equal results have been obtained with ordinary rudders worked by steam or hydraulic steering gear. About three times the length is the minimum diameter attained in large war-ships turning under the action of their rudders. In the despatch-vessel *Iris*, with steam steering gear, the diameter of the circle was from eight to nine times the length, which is to be explained by her relatively small rudder, and extremely fine form. In the *Shah* swift frigate with steam steering and a larger rudder-area, the diameter of the circle varied from five to six times the length. Corresponding facts as to merchant ships are not numerous; but it would appear that diameters from seven to eight times the length are not uncommon with steam steering gear and good helm-angles. In these ships great handiness is not sought for, moderate rudder-areas are common, and it is chiefly desired to have the vessels well under control. At the same time it may be suggested that larger rudder-areas might be advantageously adopted now that steam steering gear is so extensively used.

(4) It will be understood that in all cases the propellers of the ships were working at *full speed* when the preceding results were obtained. But it also appears that differences of speed do not greatly affect the diameters of the circles, although they affect the time of turning, so long as the helm-angle remains constant, and about the same time is occupied in putting the helm over. With steam steering or with balanced rudders these conditions may be fulfilled, and the diameter remains nearly constant in smooth water and light winds. In the *Thunderer*, for example, at speeds from 8 to 10 knots, the diameter only varied from 1400 to 1320 feet. In the *Iris*, for speeds varying from 9 to 14 knots, the diameter varied only from 2300 to 2400 feet; at the still higher speed of $16\frac{1}{2}$ knots it was nearly 2700 feet, but this was a single trial. In the *Bellerophon*, with balanced rudder and manual power, the diameter of the circle at 14 knots was 1680 feet, and at 12 knots 1650 feet. In large ships, with manual power only available at the steering wheels, a shorter time suffices

to put the helm over, or larger angles can be reached, at lower speeds, and then the diameters of the circles are decreased. In the *Warrior*, for example, while the diameter of the circle at 14 knots was 2340 feet, at 12 knots it was 1580 feet only.

(5) The time occupied in putting the helm hard over exercises a considerable influence on both the time occupied in turning the circle and upon its diameter; but more particularly affects the latter. The case of the *Minotaur*, mentioned on page 613, is a good illustration of this, and as another the trials of the sister ships *Hercules* and *Sultan* may be cited. The latter has steam-power applied to her balanced rudder, which can be put over in about half the time occupied by the manual power in the *Hercules*. The diameter of the circle in the *Hercules* was nearly twice as great as that for the *Sultan*; the time of turning for the *Sultan* was rather less than that for the *Hercules*, although the speed was half a knot less. It will be evident that the distance traversed by a ship in turning will depend upon the rapidity with which her uniform angular velocity is acquired, the rate of that velocity, and the check to her headway, all of which will be affected by the time occupied in putting the helm up. By means of balanced rudders or steam steering, the mean angular velocity, or speed with which the ends of a ship turn relatively to the middle, has in some cases been almost doubled as compared with the results obtained with ordinary rudders and manual power.

(6) Other things remaining unchanged, an increase in the rudder-area is most influential in diminishing the space traversed in turning; and this diminution may be of the greatest value to a war-ship intended to act as a ram. This point has been illustrated by the performances of the *Sultan* and *Hercules* with their rudders acting as simple balanced rudders, and with the after parts of the rudder alone at work. Further, it appears that increased rudder area and helm-angle may, in some cases, check the headway so much as to produce no greater turning effect than, if so great as, would be produced by smaller rudders and less helm-angles. In his experiments on the gunboat *Delight*, with balanced rudders of different sizes, mentioned on page 625, Admiral Sir Cooper Key found that the largest rudders diminished the space traversed in turning, made the time of turning the first quadrant less (that is, enabled the full angular velocity to be more quickly attained), but somewhat increased the time of completing the circle, in consequence of the greater check to the headway.

(7) For the same ship, with the same angle of helm and about the same time occupied in putting the helm over, the time occupied in turning the circle appears to vary nearly inversely as the speed. Take, for example, the following published results for the *Warrior* and *Hercules*:—

<i>Warrior.</i>			<i>Hercules.</i>				
Speeds.	Times of Turning Circle.		Products of Speeds by Times.	Speeds.	Times of Turning Circle.		Products of Speeds by Times.
Knots.	Min.	Sec.		Knots.	Min.	Sec.	
3	28	46	86·3	6	9	32	57·2
6	15	30	93	8	7	21	58·8
9	10	40	96	10	6	22	63·6
12	8	45	105	12½	4	28	54·2
14½	7	21	104·1	14·7	4	0	58·8

The following results for the *Thunderer* are also interesting: they relate to the second circle turned when the motion had become uniform:—

Speeds.	Times of Turning Circles.	Products of Speeds by Times.
Knots.	Min. sec.	
5·83	7 6	41·4
6·87	5 38	38·7
7·14	5 24	38·5
7·24	5 16	38·1

This approximate rule will be seen to rest upon the facts that the diameters of the circles at different speeds are practically equal under the assumed conditions, and that the loss of speed in turning bears a fairly constant ratio to the speed on a straight course. It may be of some service in estimating the time that will be occupied in turning at any selected speed, when the performance of a ship at some other speed is known; but it clearly cannot be used with safety except the fundamental assumptions are fulfilled.

(8) Up to helm-angles of 40 degrees, the turning power of the rudder has been found to increase with increase in the helm-angle. Theoretically, if the streams impinged upon the rudder parallel to the keel-line, and the effective pressure on the rudder

varied with the sine of the angle of inclination, 45 degrees would be the angle of maximum turning effect. This may be seen very easily. Using the notation of page 607, the moment of the pressure (P) on the rudder will vary very nearly as the product $P \times GA \cos a$ (Fig. 133); the distance AC from the axis to the centre of effort of the rudder being very small as compared with AG . Hence, approximately,

$$\left. \begin{aligned} \text{Moment of pressure on} \\ \text{rudder about G} \end{aligned} \right\} &= P \times GA \cos a \\ &= P_1 \sin a \times GA \cos a \\ &= \frac{1}{2} P_1 \sin 2a GA.$$

This will have its maximum value when $\sin 2a = 1$ and $a = 45$ degrees. Balanced rudders are usually arranged so that they can be put over to 40 degrees; ordinary rudders are seldom put over beyond 35 degrees, and with manual power only, the angle seldom exceeds 25 degrees in large screw steamers.

Experience fully confirms these conclusions, as will be seen from the following examples:—Admiral Sir Cooper Key found that the *Delight* gunboat behaved as under, when the helm-angle alone was varied:—

Helm-angle.	Time of Turning Full Circle.	Diameter of Circle.
degs.	min. sec.	Feet.
10	3 52	615
20	3 18	405
30	2 57	275
40	2 47	205

Admiral Halsted, in the trials conducted with the floating battery *Terror* obtained the following results:—

Helm-angle.	Time of Turning Full Circle.
degs.	min. sec.
10	6 19
20	5 28
30	5 1
40	4 42

Lieutenant Coumes, of the French navy, gives the following

results for the ironclad corvette *Victorieuse* for an initial speed of about $12\frac{1}{2}$ knots:—

Helm-angle.	Time of Turning Full Circle.	Diameter of Circle.
degs.	min. sec.	Metres.
7	9 48	1,060
14	6 50	933
21	5 50	750
27	5 20	572
$32\frac{1}{2}$	5 20	465

In practice, as has been shown above, it may happen that, with large rudder-areas, the *least time* in turning through the complete circle does not occur with the largest angle of helm, although the least diameter of circle does then occur (see page 625). But for tactical purposes the first quadrant or first half circle is more important usually than the complete circle, and within these limits large rudders at large angles economise both space and time. Moreover, in such a case the commanding officer can use his large rudder at a somewhat less angle if he wishes to turn completely round in the least time, or at the full angle, if economy of space is more important.

Attention will next be directed to some matters of practical interest relating to the determination of the areas and forms of rudders, and the helm-angle to be adopted in new ships. It will be convenient if the last-named problem is taken first. From the remarks made above it will be evident that, so far as the steering effect is concerned, a possible helm-angle of 40 to 45 degrees would be advantageous, or even a greater angle, if regard is to be had to the reduction of the effective helm-angle which takes place in turning (see page 626). Other considerations come in, however, and affect the decision. It may be very difficult with certain forms of stern to secure a large angle of helm, even when all care is taken and recourse had to various mechanical devices. Moreover, when manual power only is used, as in the great majority of ships, it becomes important, with ordinary rudders, to decide between the relative advantages of the area and helm-angle which are possible with a certain power available at the tiller-end. Mr. Barnes drew attention to this matter some years ago, basing his investigation on the old law, that the effective pressure on the rudder varied as the *square* of the sine of the angle

of inclination.* Adopting the law of the sine, it may be interesting to make a similar comparison between a narrow rudder held at a certain angle by a given force at the tiller-end, and a broader rudder of equal depth held at a smaller angle by the same force. Let it be supposed that the rudders are of similar form, so that their areas and the distances of their centres of effort (C, Fig. 132) from the axis will be proportional to the extreme breadths, B_1 and B_2 ; then for the narrow rudder we may write,

$$\text{Area of rudder} = S_1 = \text{depth of rudder} \times B_1 \times f = f \cdot d \cdot B_1,$$

where f is some fraction of the breadth applicable to both rudders. Using the notation previously adopted, a_1 being the helm-angle,

$$\begin{aligned} \text{Pressure on rudder} &= P_1 \cdot S_1 \cdot V^2 \sin a_1 \\ &= P_1 \cdot f d \cdot V^2 \cdot B_1 \sin a_1 = C_1 \cdot B_1 \sin a_1. \end{aligned}$$

$$\left. \begin{array}{l} \text{Moment of pressure about} \\ \text{axis of rudder} \end{array} \right\} = \begin{cases} \text{pressure} \times \text{AC} \\ = C_1 \cdot B_1 \sin a_1 \times r \cdot B_1 \\ = r \cdot C_1 \times B_1^2 \sin a_1. \end{cases}$$

If S_2 be the area of the broad rudder, a_2 its angle, B_2 its breadth, similar expressions will hold for it, the constants C_1 and r being identical. Hence, in order that the moments of pressure about the axes of the rudders may be equal, we must have,

$$C_1 r \cdot B_1^2 \sin a_1 = C_1 r \cdot B_2^2 \sin a_2$$

whence,

$$\frac{\sin a_1}{\sin a_2} = \frac{B_2^2}{B_1^2}.$$

The last equation succinctly expresses the relation which must hold when the force applied at the tiller-end is the same in both cases.

For the turning effect of either rudder, we may take

$$\text{Turning effect} = \text{pressure} \times \text{AG} \times \cos \text{ of helm-angle};$$

and, since AG is the same for both rudders,

$$\frac{\text{Turning effect of narrow rudder}}{\text{Turning effect of broad rudder}} = \frac{B_1 \sin a_1 \cos a_1}{B_2 \sin a_2 \cos a_2} = \frac{B_2 \cos a_1}{B_1 \cos a_2}.$$

* See his Paper in the *Transactions* of the Institution of Naval Architects for 1864.

Suppose, as an example, the narrow rudder put over to 40 degrees and the broad to 20 degrees by the same force on the tiller-end :

$$B_2 = B_1 \sqrt{\frac{\sin 40^\circ}{\sin 20^\circ}} = B_1 \sqrt{\frac{0.643}{0.342}} = 1.37 B_1.$$

$$\frac{\text{Turning effect of narrow rudder}}{\text{Turning effect of broad rudder}} = 1.37 \frac{\cos 40^\circ}{\cos 20^\circ} \\ = 1.37 \times \frac{0.766}{0.94} = 1\frac{1}{9} \text{ (nearly).}$$

The broad rudder, with an area 37 per cent. greater than the narrow one, has therefore less turning effect by about 11 per cent. If the ship had sail-power as well as steam, the smaller area of the narrow rudder would have the further advantage of checking the headway less when the ship was manœuvring under sail alone.

It will be seen on reference to page 609, that in his multiple-bladed rudders, M. Joëssel endeavoured to associate large effective rudder-area with comparatively small longitudinal dimensions in order to reduce the force required at the tiller-end, and he based his procedure on reasoning similar to that above.

Various rules have been used for determining the *area* of the rudder for a new ship. For sailing ships of former types, having lengths about $3\frac{1}{2}$ to 4 times the beam, the extreme breadth of the rudder was commonly made *one-thirtieth* of the length, or *one-eighth* of the breadth of the ship. The mean breadth of a rudder commonly varied between seven-tenths and nine-tenths of the extreme breadth. For steamships a similar rule is used, the extreme breadth of the rudder being made from *one-fortieth* to *one-sixtieth* of the length. Mr. Scott Russell has proposed to make a slight modification of this rule, the extreme breadth of the rudder being one-fiftieth of the length *plus* 1 foot. Another mode, commonly used for English and foreign ships of war, is that by which the area of the immersed part of the rudder is proportioned to the area of that part of the longitudinal middle-line section of the ship situated below the load-line; the same area which is made use of in determining the "centre of lateral resistance" for sailing ships (see page 488). As the area of this section depends upon the product of the length of the ship into the mean draught, while the rudder-area depends upon the product of its breadth into the draught of water aft, it will be seen that this rule agrees in principle with the old rule. In sailing ships, the rudder-area was often about *one-thirtieth* or *one-fortieth*

of the area of the middle-line plane; in the screw line-of-battle ships and frigates, similar values were common; from *one-fortieth* to *one-fiftieth* are common values in ironclad ships of moderate length with ordinary rudders. In the long ironclads of the *Warrior* and *Minotaur* classes, the rudder-area varies between *one-fiftieth* and *one-sixtieth* of the area of the middle-line plane; whereas in the ironclads fitted with balanced rudders it rises to *one-thirtieth*, and in some recent types in the French navy and in the Russian circular ironclads has been made *one-twentieth*. *One-fortieth* would probably be a fair average for steamships of war. In merchant ships much smaller rudders are used, and values as low as *one-hundredth* have been met with.

None of these rules can be regarded as entirely satisfactory; because they take no cognisance of the law of variation of the resistance to rotation. When the angular velocity has become constant, that resistance varies nearly as the square of the angular velocity; and the moment of the pressure on the rudder should be proportioned thereto. In fact, it appears on investigation that the pressure on the rudder, which—other things being equal—depends upon the rudder-area, should in similar ships vary, not with the area of the middle-line plane, but with the product of that area into the square of the length, if the speed of turning is to be equal, after the motion has become uniform. In this statement it is assumed, of course, that the ships compared are of similar form; the limitations, explained on page 489, for lateral resistance in sailing ships, being similar to those which will hold here. If regard is had to the initial motions of the ships under the action of their rudders, the moments of the pressure on the rudder should be made proportional to the moments of inertia of the ships. In other words, the products of the rudder-areas into the lengths of similar ships should be proportional to the moments of inertia, which will involve the product of the displacements into the squares of the lengths. The displacements will vary as the cubes of the lengths; the moments of inertia will therefore vary as the fifth powers; the area of the middle-line plane will vary as the square; and therefore, under this mode of viewing the question, the rudder-areas should be proportional to the products of the areas of the middle-line planes into the squares of the lengths. Expressed algebraically, if A_1 and A_2 are the areas of the middle-line planes of two similar ships; a_1 and a_2 the rudder areas; l_1 and l_2 the lengths: the rule would be,

$$\frac{a_1}{a_2} = \frac{A_1}{A_2} \left(\frac{l_1}{l_2} \right)^2.$$

This would give a much larger area to the rudders of long ships than is commonly adopted; and as a matter of fact, long ships usually turn more slowly than short ships in consequence of their proportionately small rudders.

Great differences of opinion have been expressed respecting the best *form* for rudders. In Fig. 134 a few of the commoner forms are illustrated. The balanced rudder *a* has been previously described; *b* is a form much in vogue for the older classes of sailing ships and unarmoured screw-ships of the Royal Navy, the broader part being near the heel of the rudder, and the narrower part near the water-line; *c* is a form now commonly used in the steamships of the Royal Navy; *d* is the opposite extreme to *b*, the broadest part of the rudder being placed near the water-line: this form is much favoured in the mercantile marine, especially for sailing ships, and is recommended on the ground that the lower part of a rudder is less useful than the upper part; but this is a misconception of the real facts of the case. From the remarks made on page 554 as to the unequal motion of the currents in the wake of a ship, it appears that the fineness of the run near the keel should make the lower part of the rudder the most effective; and this has been verified experimentally.* Hence it seems probable that, with the form of rudder *d*, the narrower, lower part does quite as much work in steering as the broader, upper part: whereas, by tapering the rudder, the power required to put the helm over is made considerably less than it would be if the breadth were uniform. These considerations would not have equal force in screw steamers where the rudder is placed abaft the screws; and then the form *c* is to be preferred, as the broadest part of the rudder is much less likely to be emerged by pitching than with the form *d*. In war-

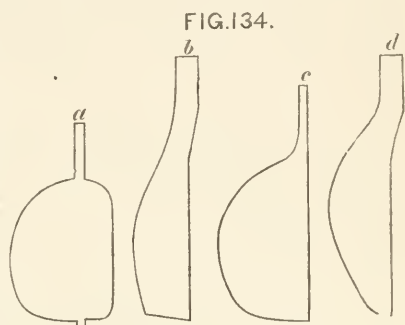

* See the account of an experiment made by Mr. Froude, cited by Dr. Woolley, in a Paper "On Steering Ships," read at the British Association in 1875. A model was fitted with a rudder of uniform breadth, divided into

two equal parts at the middle of the depth, and the lower half, when fixed at 10 degrees only, balanced the upper half fixed at 20 degrees when the model was towed ahead.

ships having under-water protective decks at the extremities, the rudder-head and steering gear are placed under those decks, six or seven feet below water. It then becomes necessary to use very broad rudders in order to gain sufficient area, and this form is advantageous also, because it enables the rudder to sweep out into the race of the twin-screws. With steam steering gear these broad rudders can be easily manipulated. In some vessels, to obtain greater command over their movements, the keel has been deepened aft, and the rudder thus made to extend below the body of the ship into less disturbed water. The case of the Chinese junks previously mentioned also bears out the advantages obtained by placing rudders in water which has a maximum sternward velocity relatively to a ship. In the floating batteries built during the Russian war, "drop-pieces" were fitted at the bottom of the rudder, and hinged to the heel, so that, when the rudder was put over, they might drop down below the keel and increase the steerage. The results in this case were not entirely satisfactory, but the circumstances of these vessels were peculiar.

A few special forms of rudders may be mentioned before passing on.

One proposed by Professor Rankine some years ago for screw-steamers was to be on the balanced principle, but to have curved sides, in order that the propeller-race in passing might communicate a pressure which should have a forward component and help the ship ahead to a small extent.

Herr Schlick has proposed a very similar rudder, the surface of which is to be twisted, so that the currents driven obliquely from the screw-propeller may move freely past the rudder when it is amidships, and not impinge upon its surface as they do upon that of an ordinary rudder. By this change it is supposed that two advantages will be gained: (1) there will be little or no check to the headway of a ship when the helm is amidships: (2) steering power will be obtained from all parts of the rudder surface immediately the helm is put over to either side, whereas with plane-surfaced rudders, placed behind screw-propellers, this is not the case. Experiments made at Fiume with small vessels are said to have demonstrated the great superiority of the new rudder in both these particulars. The following particulars have been furnished to the Author by Herr Schlick. The *Vinodol* is 140 feet long, 19 feet broad, and $8\frac{1}{2}$ feet mean draught. She was first fitted with an ordinary rudder of 26 square feet area (immersed). With 89 to 90 revo-

lutions of the screw per minute she traversed a distance of $2\frac{1}{2}$ knots in $14\frac{3}{4}$ minutes, and turned a circle of about 1000 feet diameter in $4\frac{3}{4}$ minutes. Subsequently a twisted rudder, having an immersed area of $17\frac{1}{2}$ square feet, was fitted. With the same steam-pressure and cut-off as before, 91 revolutions were made per minute, and the measured distance was run in 14 minutes 6 seconds, showing a gain in speed of about 4 per cent.; the circle turned had a diameter of 900 feet and was completed in 4 minutes 55 seconds. The vibration at the stern was also reduced.

Another special rudder is that patented by Mr. Gumpel. It is a balanced rudder as to suspension, but it is carried on crank-arms; and the fore edge has attached to it a vertical pintle, which works freely in a fore-and-aft slot cut in the counter of the ship. When the helm is put over, therefore, the fore edge of the rudder is constrained to remain at the middle line, the rudder being moved bodily over to one side of the keel by means of its crank-arms. This movement would be especially useful in the case of a twin-screw ship, since it would bring the rudder more into the race. It is asserted that the force required at the tiller-end to hold the rudder at any angle is less than that for an ordinary rudder; and the crank-arms can be so proportioned that, when the rudder is hard over, little or no force is required at the tiller to hold it there. Mr. Gumpel has tried the rudder in a small steam yacht with great success; but it has not been tested on a large scale. The plan is an ingenious one, but now that balanced rudders are giving way to ordinary rudders moved by steam-power, there is not much probability that further trials will be made on a larger scale; and there are obviously greater risks of damage and derangement with this rudder than with simple balanced rudders.

Mr. Lumley proposed to make ordinary rudders in two parts, hinging the after part to the fore part, which was attached in the usual way, to the sternpost. When the helm was put over to any angle, it moved the fore part of the rudder through an equal angle; but the after part was made to move over to a greater angle by means of a simple arrangement of chains or rods, and thus a greater pressure on the rudder was obtained. Several ships were fitted on this plan, and it was favourably reported upon in some cases, but has now fallen into disuse, at least in the Royal Navy, the principal reason probably being that the apparatus for working the after part of the rudder was liable to derangement.

Of the *auxiliary appliances* fitted to increase the steering power of ships, the most important are *bow-rudders*. These rudders are rarely fitted except in vessels which are required to steam with either end foremost; either to avoid the necessity for turning, or to be capable of service in rivers or narrow waters where there is little room for turning, or to meet some other special requirement. In nearly all cases, moreover, arrangements are made by which such rudders can be locked fast in their amidship position when the ship is steaming ahead. Few ships of the Royal Navy are thus fitted. The jet-propelled *Waterwitch*, intended to steam indifferently with either end foremost, had rudders at both ends. Many coast-defence and river-service gunboats have rudders hinged to their upright stems for use when steaming astern in narrow waters. The cable ship *Faraday* had a bow-rudder for use when steaming astern; when steaming ahead it was locked fast amidships, and similar arrangements are not uncommon in double-bowed river or ferry steamers which do not turn when reversing their course. Ordinarily, bow-rudders have been hinged at their after edge either to the stem or to an axis situated a little abaft the stem, a recess being formed to shelter the rudder when locked amidships. Several obvious objections arise to this mode of fitting, especially in war-ships, and for use when steaming ahead. Rudders so placed are very liable to damage or derangement from collision or blows of the sea. If put over to a good angle they must cause a considerable increase of resistance and disturbance of the flow of water relatively to the ship. Moreover, if hinged at their after edges to the body of a ship, these bow-rudders have a further disadvantage, if used when going ahead, because the accumulation of pressure which then takes place on the fine part of the bow abaft the rudder, on the side to which the rudder is put over, acts against the rudder-pressure and diminishes its turning effect.* This additional pressure resembles that described on page 606 as acting on the deadwood or sternpost before an ordinary stern-rudder when a ship is going ahead; only in that case it increases the turning effect of the rudder. Hence it appears that, if bow-rudders have to be used as auxiliaries to stern-rudders when a ship is moving ahead, they should be so placed that the streams flowing past them should not subsequently impinge directly upon the hull and reduce the speed of turning. This can be done either by using balanced

* This effect may often be observed in the slow motion of a Thames passenger steamer when turning astern with helm hard over to swing clear of a pier.

rudders placed in large recesses in the bow, or by placing the rudders under the bow in clear water, somewhat as has been described for the drop-rudders of Chinese junks. A rudder was placed under the bottom of a torpedo-boat built by Messrs. Herreshoff and purchased for the Royal Navy, and it was found on trial that the boat steered perfectly both going ahead and going astern. The propeller, as well as the rudder, was placed under the boat in this case; and besides steering well the boat could be stopped very quickly. Drop bow-rudders have been fitted to other torpedo boats in association with rudders at the stern. On trial they have been found to diminish sensibly both the time and space required for turning when going ahead, and to improve the steering when going astern. But the heeling effect was very marked in some of the smaller boats, especially if the helm was put over very quickly, and on this account their use has not become general (see page 630 as to heeling). In the *Polyphemus* a balanced two-bladed drop-rudder is fitted under the bow, at a part where the keel curves up considerably; and it is so arranged that, when desired, it can be drawn up into recesses in the ship. At the time of writing no extensive turning-trials have been made with this novel ship, but there is every reason to anticipate that the bow-rudder will be a valuable auxiliary to the stern-rudder when going ahead, will be of the greatest service when going astern, and will materially assist in stopping her headway rapidly. Similar rudders are being tried in one or two corvettes of the Royal Navy.

Mr. J. S. White of Cowes has recently patented a plan for increasing the manœuvring powers of boats and vessels, which has proved exceedingly successful in the boats to which it has been applied. The deadwood is cut away aft for a considerable distance, the screw-shaft being carried externally and supported at the after end from the body of the boat. A rudder is placed in the usual position abaft the screw, and before it, beneath the curved keel, a balanced auxiliary rudder is also fitted. By cutting away the deadwood the resistance to rotation is much decreased; and the two rudders working together enable the boat to be turned in a small space, both when going ahead and going astern. The speed astern is also greater than in boats of the same general form, having the ordinary arrangement of screw and rudder aft. Hitherto no trial of the plan has been made on a large scale. It will be obvious that, to gain the increased manœuvring power, certain risks have to be accepted, the propeller and rudders being unusually exposed.

Steering screws have also been suggested as a means of considerably increasing the speed of turning, or of enabling a single-screw steamship to turn without headway. The principle of most of these proposals is to fit a screw of moderate size in the deadwood either forward or aft, in such a manner that, when set in motion by suitable mechanism, its thrust shall be delivered at right angles to the keel-line. Small manœuvring screws, driven by manual power, had been previously proposed and tried in sailing ships; but Mr. Barnaby, we believe, first suggested the use of similar and larger screws, driven by steam-power, for the *Warrior* and *Minotaur* classes of the Royal Navy: proposing to fit the steering screws at the bows of these ships, in apertures cut in the deadwood for the purpose.* Subsequently the late Astronomer Royal, Sir George Airy, proposed a similar screw, but suggested that it should be placed in the after deadwood below the main propeller-shaft. Other proposals of a similar character have also been made; but we are unaware of any trials having been made on actual ships. There can be no doubt as to the manœuvring power that might thus be obtained; but considerable practical difficulties would have to be overcome in carrying the plan into practice and communicating driving power to the steering screws.

The use of water-jets expelled athwartships from orifices near the bow and stern has also been repeatedly suggested; not merely for jet-propelled vessels but for screw steamers. Trials were made of this principle on a gunboat belonging to the Royal Navy in 1863, but they were not so successful as to lead to an adoption of the plan. Nor can it be doubted, after an impartial investigation of the subject, that for a given amount of engine-power much better results might be hoped for from the employment of a steering screw, such as is described above, than from the use of water-jets.

A special form of steering screw proposed by Herr Lutschauig deserves to be mentioned.† It consists of a small screw carried by the rudder, and put over by the helm to the same angle as the rudder. By means of a simple train of mechanism the steering screw is made to revolve by the motion of the main propeller-shaft; and its thrust is always delivered at an angle with the keel when the rudder is put over. A very similar arrangement has since been patented, and fitted to several

* See the *Transactions* of the Institution of Naval Architects for 1863 and 1864.

† See the *Transactions* for 1874.

boats and small vessels by Mr. Kundstadter. Trials made with these vessels are said to have given satisfactory results both as regards speed and turning power. Prior to the actual trial of this principle it was anticipated that considerable steering power might thus be obtained if the steering screw was suitably arranged for working in the race of the main propeller. The real test of the plan must be found in its capacity for withstanding the rough usage incidental to service afloat; and as yet experience with the vessels so fitted has not been sufficiently extensive to enable a decision to be reached. It is clear, however, that the mechanism of the steering screw is of a character and occupies a position which renders it liable to derangement, while damage to it might interfere seriously with the efficiency of the main screw propeller.

The difficulties experienced in the steerage of high-speed torpedo-boats have given rise to various devices for increasing the manœuvring power. To some of these attention has been directed on page 645, and another is mentioned on page 652. One of the most ingenious mechanical arrangements made for this purpose is the "steering paddle" patented by Mr. Thornycroft. It consists of a broad-bladed paddle placed near the stern of the boat, and operated by steam-power somewhat in the manner in which a "scull" over the stern is operated by hand. In the small boat to which it was fitted it answered perfectly, and enabled her to be "slewed" without headway. On a larger scale it would also be practicable, no doubt; but it would require a comparatively large engine-power in a ship of large size to produce results at all comparable with those obtained in the experimental boat.

Professor Rankine mentions the case of a twin passenger steamer, the *Alliance*, designed by Mr. George Mills, in which manœuvring paddle-wheels were fitted at the bow and stern, the axes of the wheels lying fore and aft, and their thrust being delivered athwartships. No reports of the performances of this vessel are recorded, but we are informed that the plan was adopted chiefly to enable the vessel to "cant off" from the piers on the Clyde.

Auxiliary rudders of various kinds have been tried, but none have proved so successful as to pass beyond the experimental stage, or to be used apart from the special circumstances for which they were devised. In some of the floating batteries built during the Crimean War, in which the shallow draught and peculiar form made steering very difficult, auxiliary rudders were

fitted on each side at some distance before the stern, and arranged so that they could be put over to an angle of about 60 degrees. No sensible improvement in the steering appears to have resulted from these additions. Another form of auxiliary rudder was proposed by Mr. Mulley, and tried at Plymouth in 1863. It consisted of a rudder fitted on each side of the after deadwood, at a short distance before the screw aperture; it was hinged at the fore edge, and, when not in use, could be hauled up close against the side, but, when required, could be put over to 38 degrees from the keel-line. When applied to a paddle-wheel tug, it answered admirably, steering her by its sole action, and making her turn more rapidly when acting in conjunction with the main rudder. It completely failed, however, when tried on her Majesty's screw-ship *Cordelia*, and produced a distinct turning effect on the ship in the direction opposite to that in which it was expected to act. The explanation of the failure suggested by the inventor is probably correct: the action of the screw-propeller may have produced a negative pressure on the side of the deadwood abaft the auxiliary rudder when it was put over; and the turning effect of the negative pressure more than counterbalanced the effect of the auxiliary rudder. Possibly, if the latter had been placed further before the screw, it might have succeeded, as it did in the paddle-wheel vessel.

Another kind of auxiliary rudder was tried in her Majesty's ship *Sultan*. She was fitted with sliding rudders, one on each side, arranged so as to counterbalance one another; when one was allowed to project under the counter, the other was drawn up into a casing within the ship, and both could be "housed" when desired. The area of each of these auxiliaries, when fully immersed, was about *one-sixth* of the area of the main balanced rudder, and it was set about 50 degrees from the keel-line. On trial it was found that the small area and the position of the auxiliary rudder rendered its steering effect so small as to be practically unimportant.

The most recent trials of auxiliary rudders in the Royal Navy were made in the corvettes of the *Comus* class. It was desired to give these unarmoured vessels the advantage of a submerged rudder in addition to the ordinary rudder, for use in case of damage to the latter in action. For this purpose a recess was formed in the deadwood under the shaft, and before the single screw propeller. The auxiliary rudder was placed in this recess, hinged at the fore end, and when housed amidships it nearly made good the recess in the deadwood, completing the shape of

the ship. It could be put over to nearly 30 degrees, but as manual power only was available, the time occupied in putting the helm over was very long. On trial it appeared that, although the area of the auxiliary rudder approached equality to that of the ordinary rudder, it possessed little steering power. It was then decided to fit side-blades on the Joëssel principle as a further experiment, and when this was done the auxiliary rudder proved capable of turning the ship in about three times the period which sufficed for a complete circle with the ordinary rudder, the diameter of the circle being increased about four times. This result was not satisfactory, and, as it involved a sensible loss of speed, when the auxiliary rudder was locked amidships, it was finally decided to remove the side-blades, and to leave the single-bladed rudders as first fitted, simply as a reserve in case of damage. In subsequent vessels of the class similar rudders have not been fitted. These experiments incidentally furnished remarkable evidence of the gain in steering effect, for the ordinary case of headway, obtained by placing the rudder abaft the screw. For sternway it is probable that such auxiliary rudders may be found useful.

Steering blades or boards somewhat similar in principle to those tried in the *Sultan* have been used successfully in vessels designed for shallow-water service. These blades were set at an angle of about 45 degrees from the keel-line on either side, and could be pushed out from the stern or dropped down into the water on the side towards which the head of the ship was to be turned. The idea is an old one, and has been made use of on some occasions to steer sea-going ships which have lost their main rudders.

Of the very numerous plans of "jury rudders" which have been proposed, we can say nothing in the space at our disposal. They are all based upon the principles explained above for the ordinary rudder, and are more or less satisfactory expedients for taking the place of the rudder properly belonging to any ship.

In conclusion, allusion must be made to various methods of steering steamships by means of their propellers alone, independently of the action of the rudder.

Single-screw ships, as ordinarily fitted, do not possess this power. As explained on page 603 they can be slewed without headway by using the rudder and the screw. It is also a matter of common experience that, with the helm amidships and screw in

motion, a single-screw ship can be turned completely round; but this cannot be called steering, since the commanding officer has no control over the direction in which the ship turns (see the results of trials stated on page 605). In most cases the turning under these circumstances will be performed slowly and in circles of large diameter. This steering effect of the screw results chiefly from the unequal thrust delivered on the blades during their motion in consequence of the unequal forward motion of layers at different depths in the wake; as explained on page 554.* In well-immersed screws the upper blades experience the greatest thrust; and the excess in the transverse component of this thrust over the corresponding component of the thrust on the lower blades gives a steering effect, which tends to turn the bow of the ship towards the side on which the screw descends. If the screw be right-handed the head of the ship will usually turn to starboard, if it be left-handed she will turn to port, under the action of a well-immersed screw, and when proceeding at uniform speed ahead. Under these conditions also, if the helm is left free, the rudder will rest in a position inclined to the keel-line, on that side towards which the particles of water in the race are driven by the lower blades of the propeller. Should circumstances occur to cause a relief of thrust on the upper blades, and to make the thrust on the lower blades the greater of the two, the steering effect will, of course, be different. This may happen, if the screw is not well immersed, or in starting from rest, or in suddenly reversing the engines when the ship is at speed on a given course. Many interesting facts bearing on this subject will be found in the Reports of the British Association Committee, mentioned on page 604, but they cannot be reproduced here. It must be added, however, that when the rudder is in use the screw also exercises a steering effect of the kind described, and makes it possible to turn a ship more quickly in one direction than in another, when she is moving ahead. The difference in the times of turning is more considerable in some cases than in others. For example, in the *Bellerophon* turning to starboard the circle was completed in 4 minutes; but turning to port, a circle of the same diameter occupied 4 minutes 20 seconds. In the floating battery *Terror*, where the peculiar shape of the stern gave a great excess of thrust to the upper blades, the circle with starboard helm occupied 5 minutes 12 seconds, and that with

* See also Professor Osborne Reynolds' Paper in the *Transactions* of the Institution of Naval Architects for 1873.

port helm 6 minutes 18 seconds. With the helm left free she turned to port and completed a circle in 5 minutes 52 seconds, or less time than she turned to starboard (with port helm) under the action of her rudder hard over. On consideration it will be seen that, when the rudder is used in a ship with her screw well immersed, the streams delivered by the lower blades impinge more directly upon the lower part of the rudder when it is put over to the side on which the blades descend when the ship is going ahead, than they do when the rudder is put over to the other side. This circumstance further assists the steering to one side as compared with the other. No general rule can be stated including all these varying conditions, but commanders soon become familiar with the general tendency in a particular ship. And pilots always allow for the steering effect of the screw in entering rivers, harbours, or docks.

Various proposals have been made for the purpose of gaining steering-power from the direct thrust of single-screws. One of the earliest plans was that proposed by Mr. Curtis, in which the screw was attached to the shaft by means of a suitable joint, and was carried by a frame hinged like a rudder to the stern. The frame, carrying the propeller, could be put over with the helm to any angle desired; and the thrust of the screw, driven by the main engines, was then delivered at an angle with the keel-line, exercising a powerful turning effect on the ship. On trial it was found that this turning effect was very powerful indeed, and the motions of the small vessel so fitted were very rapid; but there was far less control over the motion than with the rudder, and this fact, together with the difficulties and risk of derangement to the propelling apparatus which would attend the adoption of the plan on a large scale, has prevented its use.

Recently a most ingenious plan for effecting the same object has been patented by an American, Colonel Mallory, who has devised a method for rotating the screw through a complete circle, and meanwhile keeping the main engines running continuously in one direction. A boat fitted with the Mallory propeller can be turned almost on her centre, stopped very rapidly, and kept thoroughly under control by the action of the screw alone, no rudder being fitted. The American torpedo vessel *Alarm* (of 140 feet length and 750 tons displacement) has also been fitted with this propeller, and the Report of the Board of Naval Engineers who conducted the trials is very favourable. It is asserted that, without any loss in efficiency as a propeller when compared with single or twin-screws, there is an enormous gain in manœuvring

power. The only drawbacks are considered to be "increased cost and complexity of mechanism and necessarily decreased reliability and durability," but for torpedo-boats, small rams and gun-boats, the Board consider the advantages of the Mallory system to far outweigh its disadvantages. Further experience with the *Alarm* will give valuable information as to possible extensions of the system to special classes of ships in which handiness is of supreme importance.

Another very ingenious and promising method of increasing the manœuvring power in single-screw ships has been fitted by Mr. Thornycroft to a large torpedo-boat, in connection with the novel form of propeller described on page 560. The "guide-blades" behind the screw are enclosed by a casing, and abaft this casing is another casing carried by the rudder. When the helm is put over, the water from the screw is therefore delivered into the after casing which is set obliquely to the keel-line, and the manœuvring power thus obtained has proved to be most remarkable on trial, the boat which previously traversed a large circle in turning could be slewed almost without headway, the bow remaining nearly at rest.

A clever manœuvring propeller was invented some years ago by Mr. Moody and applied to a few barges on the Clyde. It was subsequently proposed by Mr. Fowler, who does not appear to have been aware of the other invention, and fitted to the American torpedo-vessel *Alarm* as well as to a few small vessels. This propeller consists of a feathering paddle-wheel placed at the stern, the axis of the wheel being vertical. By means of suitable mechanism the paddle-floats can be made to "feather" at any point in their revolution; and in this way the maximum thrust can be delivered in different directions, and made either to propel the vessel ahead or astern, or to steer her on any desired course. The apparatus is said to have answered well in the *Alarm*, as regards handiness, but not to have been favourable to speed. It has since been removed, and a Mallory propeller substituted, with a considerable gain in speed and even greater handiness. Another American invention of a very similar kind consists of two feathering wheels placed on opposite sides of the stern-post and made to revolve in opposite directions when the ship is turning. All such propellers are obviously more liable to derangement, damage and fouling than screws, nor can they be so efficient as propellers.

Vessels fitted with duplicate propellers, such as disconnecting paddle-wheels, water-jets, or twin-screws, can be manœuvred more

or less successfully by the propellers alone. By making one propeller deliver its thrust ahead and the other astern, a ship can be made to turn nearly on her centre without headway; if only one propeller is used, she will describe a circle of more or less considerable diameter; and if the rudder is used in association with either of these conditions it is possible to increase the speed of turning or lessen the space traversed. The principle is the same for all three propellers, but the distance between the lines of thrust of twin-screws is commonly less than *one-half* the extreme breadth of a ship, whereas, with disconnecting paddles, the corresponding distance would commonly be *four-thirds* the extreme breadth; and with water-jets the distance somewhat exceeds the breadth. Notwithstanding this advantage, twin-screws compared favourably with water-jets on the only occasion on which we know their turning powers to have been tried in competition. No similar competitive trials appear to have been made with twin-screws and disconnecting paddles; but the restricted use of paddle-wheels makes it unnecessary to inquire into their relative merits.

Turning trials with twin-screw vessels have established the following conclusions:—

(1) That with *ordinary* rudders of suitable forms and areas such vessels can be steered as efficiently as single-screw ships, when both screws are working full speed ahead. Balanced rudders applied to twin-screw ships have not always been so successful as in single-screw ships; but this partial failure probably arose from the fore-and-aft position of the twin-screws, as in other cases better performances have been obtained with twin-screw ships fitted with balanced rudders than with sister ships fitted with ordinary rudders. For example, the *Iron Duke*, with twin-screws and an ordinary rudder, occupied about 4 minutes 38 seconds in turning a circle 505 yards in diameter; her sister ships, the *Audacious* and *Invincible*, with balanced rudders, occupied about $4\frac{1}{3}$ minutes, and turned in circles having diameters of about 400 and 325 yards respectively. Compare with these the performances of the *Resistance*, a single screw-ship of the same length and displacement, with an ordinary rudder; she occupied $6\frac{1}{2}$ minutes in turning a circle 600 yards in diameter, and although her lower speed would account for some part of the slowness of turning, her performance, on the whole, was distinctly inferior to that of the twin-screw ships.

(2) That with helm amidships, one screw working ahead and the other astern, such vessels can be turned nearly upon their own

centres, but the time of turning is considerably greater than when both screws are working ahead and the rudder is used. It will be remarked that, when the screws are thus worked, that which is turning ahead delivers its race aft, and tends to diminish the pressure on that side of the deadwood to which it is adjacent; whereas that which is turning astern delivers its race forward and tends to increase the pressure on its side of the deadwood. The head of the ship turns towards that side where the screw is working astern, and consequently the excess of pressure on the same side of the deadwood aft helps the thrusts of the propellers in turning the ship. This fact tells sensibly in favour of the manœuvring power of twin-screws. Another circumstance worth noting is the difference which exists between the effective thrusts of the two screws; that which is working ahead has the greater thrust, and the excess in thrust constitutes a force tending to propel the vessel ahead, increasing the space she requires in turning. If the ship is of fine form and easily moved at moderate speeds, she may therefore traverse a considerable space in turning under the assumed conditions; if she is of large size and full form the difference in the thrusts may only suffice to give her a small speed when she will occupy little space. To illustrate this statement we may take the cases of Her Majesty's ships *Iris* and the ill-fated *Captain*, which have nearly equal lengths. With one screw ahead and one astern, the *Iris* traversed a circle of about 500 yards diameter, say 5 times her length; whereas the *Captain* traversed a circle of 150 yards mean diameter, or about $1\frac{1}{2}$ times her length. By suitably adjusting the revolutions of the engines, a twin-screw ship might, of course, be turned upon her centre.

(3) That when the screws are working in opposite directions, as in the preceding case, if the helm is put over, the time of turning is usually greater than when both screws are working ahead and the rudder is used; but the vessels turn nearly upon their centres. For example, the *Captain* took 5 minutes 24 seconds to complete a circle of 750 yards diameter with both screws full speed ahead and helm hard over; as against 6 minutes 52 seconds in the other condition, when she turned nearly on her centre. The explanation of the difference is to be found in the diminished efficiency of the rudder produced by the absence of headway, as well as by the action of the screw which is working full speed astern on the side towards which the rudder is put over. It is worthy of remark, however, that the rudder does some work under these circumstances; for the time

of turning has been found to be less than when the same vessel was turned by the action of the screws alone. Mr. Barnaby gives a case where the times for the two conditions were respectively $4\frac{1}{4}$ minutes and 6 minutes 55 seconds. A possible explanation of this circumstance may be found in the turning effect of the accumulated pressure that will act on the side of the deadwood before the rudder, and will assist the screws in turning the ship.

(4) That when one screw is stopped and the other worked full speed ahead, with the rudder hard over, vessels can be turned somewhat more slowly than when both screws are working ahead. As to the relative diameters of the circles described under these two conditions, there is less agreement. Mr. Barnaby gives a case where a twin-screw ship completed the circle in 3 minutes 48 seconds with both screws working ahead; and in 3 minutes 58 seconds with one screw stopped; the diameter of the circle in the latter case being one-third less than in the former. In the *Captain*, the corresponding results were 5 minutes 24 seconds to complete a circle 750 yards in diameter, when both screws were worked ahead, and 7 minutes 50 seconds to complete a circle 874 yards in diameter, when one screw was stopped. In the *Iris* the corresponding results were 8 minutes 14 seconds to complete a circle of 767 yards diameter at a speed of 10 knots with both screws, and 10 minutes to complete a circle of 613 yards diameter with one screw stopped.

(5) That with one screw only at work and the helm amidships, the ship can be turned completely round; but the time of turning is considerable, and the diameter of the circle large as compared with the other modes of turning. In the *Captain*, about $9\frac{3}{4}$ minutes were occupied in turning a circle nearly 1100 yards in diameter. Even this turning power might be of service, however, to a vessel of which the rudder and one screw had been damaged.

(6) That with one screw at work ahead the other being stopped, or allowed to revolve freely, the ship can be kept on a straight course by the use of the helm. The angle of helm required varies in different ships, and possibly at different speeds in a given ship. In the *Iris* at speeds of 7 to 8 knots about 8 degrees to 10 degrees of helm sufficed. In the *Nelson* at 10 knots, 16 degrees of helm were required. Other cases have come under notice where the helm hard over did not keep a ship straight; but the fact simply proved that either the maximum helm-angle available was too small or that a form and area of rudder had been adopted which were not suited to the ships. For effectiveness under these

conditions the rudder should clearly be made broad in order to sweep out into the race of the screw at work.

It is usual in twin-screw ships to place the shafts parallel to one another and to the keel; but more than once it has been suggested that advantage in steering might result from making shafts diverge from one another, in order to increase the leverage of the thrust of either propeller about the centre of gravity. This plan has been applied in the *Faraday*, a ship built for the special purpose of laying submarine telegraph cables, and therefore requiring great handiness under all conditions of wind and sea. It is said to have proved very successful; and with the rudder locked amidships, some of the most delicate operations connected with laying and splicing cables were performed in a rough sea and strong wind, the ship being manœuvred by the screws alone. The shafts in this vessel diverge from parallelism with the keel-line by being at a greater distance from it at their fore ends than at the after ends; abreast of the centre of gravity the distance between the shaft-lines is about 40 feet, near the propellers the distance is about half as great. Another interesting fact in the management of this exceptional vessel is that, in order to maintain her position with wind or sea on the beam, the two propellers were frequently worked at different speeds and sometimes in opposite directions. She furnishes, in fact, one of the most remarkable illustrations of the manœuvring power obtainable by the use of twin-screws.*

Jet-propelled vessels, when moving ahead at full speed, derive their steering power from the reaction of the water in the wake upon the rudder; and as previously explained, this is likely to be less than that on a rudder placed in the race of a screw. In the trials made with the twin-screw ship *Viper* and the jet-propelled *Waterwitch*, there was practical identity of length and draught, as well as approximate equality of displacement and speed; but the *Viper* was constructed with two deadwoods, and had a rudder on each, while the *Waterwitch* had only one rudder at work, the rudder at the fore end being locked. Hence any exact comparison between the manœuvring powers of the two systems of propulsion can scarcely be made from the trials of these ships; but the following facts may be interesting. When steaming full speed ahead, the *Viper* turned a circle in 3 minutes 17 seconds, as compared with 4 minutes 10 seconds for the *Waterwitch*; a saving

* See an account of the vessel, field, F.R.S., to the Institution of Naval Architects in 1876.

of time in the twin-screw ship of about 20 per cent. With one screw reversed, the other full speed ahead, and the rudders hard over, the *Viper* turned on her centre in rather less time than with both screws working full speed ahead (3 minutes $6\frac{1}{2}$ seconds, mean of trials in opposite directions).* The *Waterwitch*, under similar conditions, with one nozzle reversed, also turned on her centre, but occupied more than twice the time of the *Viper* ($6\frac{1}{2}$ minutes), and half as long again as she took when steaming full speed ahead. Making allowance for the additional rudder of the *Viper*, and the additional resistance to turning which her peculiar form of stern involves, it appears that the twin-screws possess some advantages over the jets in manœuvring; but further trials would be required to settle this point conclusively. It is, however, certain that ample manœuvring power can be secured with twin-screws in association with greater propelling efficiency than has yet been obtained, or is likely to be secured with water-jets.

In conclusion it may be remarked that, throughout the preceding discussion, it has been assumed that the manœuvres of ships are performed in smooth water, in order that the principles of the action of the rudder, or of auxiliary appliances for steering, might be more simply explained. When ships are manœuvred in rivers, currents, or a seaway, their performances necessarily differ from those in still water; but all the varying conditions of practice can scarcely be brought within the scope of exact investigation; and the foregoing statement of principles will probably enable the conditions of any selected case to be intelligently treated.

* It will be observed that this is an exception to the deduction marked No. 3 on p. 654; but the explanation of the difference is simple. As the *Viper* has two rudders, that placed behind the screw, which was driving

the ship ahead, always remained thoroughly efficient in assisting to turn the ship, although the other rudder, placed behind the screw, which was driving the ship astern, was less efficient.

INDEX.

- ADMIRALTY :—
 Regulations for preservation of iron and steel ships, 408
 Coefficients for steamship performance, 566
- Air resistance to motion of ships, 477, 479
- American :—
 Tonnage law for war-ships, 43
 River steamers: special construction of, 314, 360
 Wood-built ships, rapid decay of, 382
- Angular velocity of ships :—
 When rolling, 135, 158
 When turning, 615, 616
- Ardency of sailing ships, 492
- Armour :—
 Contribution of, to structural strength of ships, 343, 344
 Progress in manufacture of, 410
- Atwood's formula for statical stability, 118
- Augment of resistance due to screw-propeller, 544, 551
- Augmented surface, 447
- Automatic instruments for measuring and recording rolling, 274, 275
- Axis of rotation of a ship :—
 When rolling, 137
 When turning, 618
- BALANCED rudders: their advantages and disadvantages, 598, 599, 609, 611, 613
- Barques :—
 Plain sail of, 494
 Position of centre of effort of sail, 503
 Stations of masts and base of sail, 505
- Batten instruments for observing rolling and pitching, 272
- Beam of ships :—
 Effect upon metacentric stability, 90
 „ range of stability, 120
 „ the resistance and propulsion, 458, 459, 470, 583
 Ratio to length in sailing vessels, 512, 514
 „ „ unarmoured war-ships, 461
 „ „ ironclads, 461, 580
- Beams :—
 Calculations of bending moments due to loads on, 286
 Principles of strength, 333, 344
 To decks: as transverse strengtheners of ships, 305, 317, 372
 Methods of scarphing wood, 393, 394
 Sectional forms in iron or steel, 397
 Approximate rules for strength, 398
 Knees of, 375
- Bearers, longitudinal, contribute to local and general strength of ships, 313
- Behaviour of ships at sea (*see* Rolling and Pitching).
- Bending moments :—
 Methods of estimating, for beams, 286
 Longitudinal, for ships, 283, 297, 299, 365
 Transverse, for ships, 304, 305, 310
 Resistance of beams and girders, 334
 „ ships to longitudinal, 335
 „ ships to transverse, 367
- Bilge-keels :—
 Means of increasing fluid resistance to rolling, 161, 163, 165
 Means of increasing steadiness in a sea-way, 241
- Boilers :—
 Locomotive, 523, 527, 528
 Herreshoff, 524
 Forced draught in, 524

- Bottom, double (*see* Double Bottom):—
 Of iron ships, special dangers of, 315, 406
 Of wood ships, strong against grounding, 315
- Bow rudders, 644, 645
- Bows of ships:—
 Influence of form upon pitching, 258
 „ „ upon resistance, 459
 Construction of, for ramming, 319
- Bowsprits, steeve of, 506
- Bracket frame: system of construction for iron ships, 351, 354, 370
- Brass skins, 326
- Brigs:—
 Loss of older classes by swamping, 14
 Plain sail, and position of centre of effort, 494, 503
 Stations of masts, and base of sail, 505
- Buckling, special danger of, in iron or steel ships, 316, 349, 396, 428
- Builders' old measurement tonnage:—
 Antiquity of rule, 38
 Examples of calculation, 40
 Rationale of rule, 40
 Objections to, and abolition of, 41, 42
- Bulkheads, as watertight subdivisions:—
 Arrangement of transverse, 17, 26
 „ of longitudinal, 21, 26, 28, 29
 Necessity for care of, and doors to, 413
 Protection against fire, 414
 Means of maintaining stability, 105, 106
 Use of transverse, 314, 367, 377
 „ partial, 353
 „ longitudinal, 359
- Buoyancy:—
 Definition of, 2
 Reserve of, in different classes of ships, 11
 Loss of, causes ships to founder, 13, 14
 Centre of, 73, 89
 Strains due to unequal distribution of weight and, 284, 288, 290, 299
- Butt joints:—
 In wood ships, 329, 391, 394
 In iron ships, 395
- CAPTAIN, Her Majesty's ship (*late*):—
 Curve of stability and principal dimensions, 123, 124
 Safety under sail in still water, 170
 Upsetting angle, amongst waves, 248
- Cargoes:—
 Dangers of shifting, 103
 Stowage of, checked by rolling experiments, 156
- Cellular construction for iron ships, 316, 349, 351
- Central-citadel ironclads:—
 Ram-bows of, 320
 Forms and proportions of, 461, 583
- Centre boards of sailing vessels, 489
- Centre of buoyancy:—
 Defined, 73
 Approximate rules for position of, 89
 Motion of, as ship heels, 117, 121
- Centre of effort of sails:—
 Method of estimating position, 502
 Longitudinal position of, 503, 507
 Vertical position of, 508, 511
- Centre of flotation, 137
- Centre of gravity:—
 Weight may be supposed concentrated at, in ship at rest, 73
 Height of metacentre above, in various classes of ships, 79, 82, 86, 129
 Inclining experiment to determine vertical position of, 98
 Motion of, when weights are shifted, 99, 103
 Effect of vertical position of, upon range of stability, 122
 Effect of position of, relatively to centre of effort of sails, 507
- Centre of lateral resistance, 502
- Centre of pressure on rudder, 608
- Chinese junks, steering of, 642, 645
- Cigar-ships:—
 Conditions of stability for, 97
 Curve of stability, 119
 Still-water oscillations of, 137, 139
- Circular ironclads, Russian:—
 Behaviour at sea, 235
 Weights of hull for, 384
 Rolling in a seaway, 214
 Steaming capabilities of, 583, 588
 Rudder arrangements and steerage, 617, 640
- Clipper ships, proportions and performances, 513
- Coal consumption, rates of, for various types of engines, 523
- Coal protection, 425

- Coefficients of:—
 Augmentation (Rankine's), 447
 Fineness, for displacement, 3
 Moment of inertia of plane of flotation, 89, 90
 Friction (skin), 438
 Steamship performance, 566, 576
- Collision:—
 Examples of accidental, 30, 31, 318
 Local strains produced by, 317, 318, 319
 Construction of ram-bows to withstand, 319, 320
- Compartments, watertight:—
 Methods of forming, 17, 18
 Of ironclad ships, 27
- Composite ships:—
 Arrangements of decks, 345
 „ framing, 349
 „ skins, 357, 358
 „ beam-end connections, 373
 Freedom from fouling of the bottom, 416
- Compound engines:—
 Economy of fuel with, 523
 Weights of, 523
- Compressive strengths of wood and iron, 388, 390
- Copper sheathing:—
 Anti-fouling properties of, 417
 For iron ships, 417, 420
 Protected by zinc bands, 418
 Insulation of, in *Inconstant* class, 421
- Corinthian Yacht Club, rule for tonnage, 69
- Corrosion of iron ships:—
 Causes of, 403, 406
 Experiments on rate of, 419, 422
 Means of preventing, 403
- Curves of:—
 Displacement, 6
 Extinction for rolling in still water, 152, 167
 Flotation, 137
 Loads and bending moment, 288, 291
 Metacentres and centres of buoyancy, 91, 96
 Progressive speed trials, 572
 Resistance for models and full-sized ships, 471
 Rolling motion of a ship under sail, 250
 Stability, 120, 123, 125, 128
 Tons per inch of immersion, 7
 Turning for steamers, 618, 621
- Cutters:—
 Plain sail for, 494
 Position of centre of effort, 503
 Station of mast and base of sail, 505
- DANUBE rule for tonnage, 52, 58
- Dead-weight tonnage for merchant ships, 37, 60, 61, 64
- Decks:—
 Contributories to longitudinal strength, 345
 Local strains on, 316
 Require strengthening in many iron ships, 366
 Resistance of, to rolling and pitching, with low freeboard, 167, 258
 Utilised as watertight partitions, 19, 23
- Devastation:—
 Inclination under wind pressure, 172
 Mr. Froude's rolling experiments with model, 163, 241
 Performances at sea, 224, 228, 255
 Compared with circular ironclads, 585
- Diagonal riders:—
 For ordinary wood ships, 344, 356
 Not necessary for iron ships, 359
 For composite ships, 358
 Framing for iron ships, 359
 Planking for wood and composite ships, 358
- Dipping oscillations of ships, 148
- Disc area of screw propellers, 543
- Dismasting of merchant sailing ships, 324
- Displacement:—
 Approximate rules for, 3
 Compared with B.O.M. tonnage, 42
 „ „ gross register tonnage, 64
 Curves of, 6
 Definition of term, 1
 Most suitable tonnage for war-ships, 43
 Tonnage recommended for yachts, 69
- Double bottoms:—
 Cellular construction of, 316, 354, 359
 Effect upon stability of water ballast in, 107
 Facilitate preservation of skins, 409
 Uses of, in iron ships, 25, 27
- Draught of water:—
 Changes in, by altered density of water, 9
 „ „ addition or removal of weight, 7
 Displacement for any, 6

- Draught of water (*continued*):—
 Effect upon, of entry of water into hold, 18
 With changes of trim, 113
- Durability of wood and iron ships compared, 403
- Dynamical stability (*see* Stability).
- ECONOMICAL propulsion of steamships:—
 Favoured by suitable forms and proportions, 463, 580
 Favoured by increase in size, 588, 591
 „ certain types of machinery, 525
 „ suitable propellers, 557
 Not of paramount importance in all cases, 461, 581
- Eddy-making resistance of ships, 434, 449, 460
- Effective horse-power, 518, 579
- Efficiency of marine engines, 523
 „ propellers, 533, 547
 „ steamships, 580
- Elastic limit, 386
- Engines, marine:—
 Measures of power, 518
 Of swift steam-launches and torpedo-boats, 523, 528, 593
 Types in common use, 522
 Weights per indicated horse-power and rate of coal consumption, 523
- Entrance of ships: connection between speed and length of, 452
- Equilibrium of ships:—
 When floating in still water, 1, 73
 Stable, unstable, and indifferent, 75, 78
 Instantaneous position of, among waves, 212, 218
- Experiments:—
 Against targets representing sides of unarmoured ships, 424
 On air resistance, 477, 479
 On deck resistance to rolling, 167
 On rate of corrosion of iron, 419, 422
 On resistance of ships, 435, 471, 477, 479
 „ „ wood and iron to penetration, 315
 On screw propulsion, 550, 557, 559, 561
 On screws and paddle-wheels, 561
 „ „ water-jets, 535
 On steerage of single-screw ships, 604, 650
 „ „ twin-screw ships, 653
 „ „ jet-propelled ships, 657
- Experiments (*continued*):—
 On still-water rolling, 151
 On strengths of iron and steel, 387, 391, 426
 On strengths of timber, 388, 390
 On the effect of bilge-keels, 161, 165, 241
 On waste of metals in sea water, 419
 To determine vertical position of centre of gravity of ships, 98, 99
 To determine “quiescent point” or *point tranquille* of ships, 154
- FACTORS of safety for wood and iron, 388, 390
- Fastenings in ships:—
 Importance of proper, 326
 Metal bolts in wood ships, 393
- Filings, between frames of wood ships, very useful, 315, 347
- Flanged forms of beams and girders very advantageous, 344, 399
- Formulae:—
 Admiralty, for steamship performance, 566
 Atwood’s, for statical stability, 118
 Centre of pressure on rudder, 608
 Expressing relative economy of steam-power in large and small steamers, 589
 For augmented surface of a ship, 447
 Heeling force when steering, 628
 Maximum angle of heel in unresisted rolling among waves, 223
 Moseley’s, for dynamical stability, 146
 Normal pressure on a plane advancing obliquely, 436
 Period of unresisted rolling in still water, 140
 Sail-carrying power, 509
 Trochoidal waves, 187
- Fouling of bottom:—
 Especial disadvantage of iron ships, 415
 Effect on resistance of ships, 416, 448
 Proposals for preventing, 417, 424
- Foundering of ships, causes of, 13
- Framing of ships:—
 Diagonal, for iron ships, 359
 Longitudinal, for iron ships, 351, 352
 Subordinate to skins, 326
 Transverse, in iron and composite ships, 348, 368
 Transverse, in wood ships, 348, 368

- Freeboard :—
 Various rules for, 33, 34
 Effect of, upon the stability, 120
- Freight-tonnage, 67
- French :—
 Experiments on still-water oscillations, 154, 159
 Observations of deep-sea waves, 198, 205, 207
 Rule for nominal horse-power, 521
- Frictional resistance :—
 To rolling of ships, 157, 159, 235
 To motion of ships, 436, 438
 Constant, of engines, 563
 Importance of, 448, 460
- Froude, the late Mr. W., F.R.S. :—
 Investigations on resistance to oscillation of ships, 151, 241
 Modern theory for rolling among waves, 211
 Report on behaviour of *Devastation*, 228
- Experiments :—
 On usefulness of bilge-keels, 163, 241
 On resistances of ships and models, 433, 444, 456, 471
 On relative efficiencies of upper and lower parts of rudders, 641
 On frictional resistance, 438
 On wave-making resistance, 455, 457
 On air resistance, 482
 On ratio of effective to indicated horse-power, 579
 On screw propulsion, 548
 On circular ships, 584, 585
 On planes and rudders, 608, 641
- GALVANIC action :—
 Accelerates corrosion of iron skins, 421
 Assists in preventing fouling of zinc sheathing, 419
 Means of preventing, 422
 Special danger in iron ships copper-sheathed, 421
- Girders :—
 Equivalent, for longitudinal strength of ships, 331, 336
 Comparison of ribs and adjacent parts of skin to, 368
 Lattice, used as strengtheners to shallow ships, 361
 Principles of strength, 334
- Graphic integration, 250
- Greyhound*, Her Majesty's Ship :—
 Rolling experiments in still water, 161
 " " in a seaway, 242
 Model experiments on resistance, 471
 Used as basis for calculations of performance under steam of large ships, 577
- Grounding, local strains produced by, 314
- Gunboats, unarmoured :—
 Use of iron hulls for, 425
 Engine-power and speeds, 595
 Selection of forms and proportions for, 470
- HEAD resistance, to motion of bodies through water, 434
- Headway, advantage of, to ships in turning, 601
- Heaving of ships among waves, 186, 247
- Heeling produced by :—
 Entry of water into hold, 22
 Action of wind on sails, 75, 169, 310, 488, 508
 Shifting weights athwartships, 102
 Turning, 627
- Helm :—
 Angle of greatest efficiency, 637
 Importance of quick motion, 612, 616
 Power to put it over, 609
 Starboard and port: weather and lee, 599
- Hog frame in shallow-draft vessels, 360
- Hogging :—
 Causes of, in still water, 284
 " on wave crest, 294
 Conditions of strain incidental to, 299, 365
- Holyhead packets, steaming capabilities of, 542
- Horse-power of marine engines :—
 Effective, 518
 Indicated, 518
 Nominal, 519
- Hulls of ships :—
 Advantages of iron as compared with wood, 383
 Recent use of steel, 426
 Should combine lightness with strength, 2
 Suitability of iron for unarmoured war-ships, 425
 Weights of for various classes, 384

- IRON, as a material for shipbuilding :—
 Compared with wood, 382
 Modulus of elasticity, 391
 Progress in manufacture of, 410
 Resistance to bending strain, 398
 „ „ perforation, 315
 Simple combinations possible with, 395
 Tensile and compressive strength of, 387, 391
 (See also Corrosion Fouling and Wood.)
- Ironclads :—
 Behaviour at sea, 227, 230
 Cost of maintenance and repairs, 412
 Expenditure of engine-power, 595
 Local requirements in structures, 364
 Long and short types compared, 582
 Longitudinal strains of, 363
 Rapid decay of wood-built, 402
 Rudder areas of, 640
 Sailing capabilities of, 500, 509
 Speeds under steam, 516, 581
 Structural arrangements of, 351, 370
 Watertight subdivision of, 27
 Weights of hull for, 384
- Iron ships :—
 Beam-end connections, 373
 Causes of corrosion, 403, 406
 Compared with steel ships, 426
 Construction of decks, 345
 „ „ ram-bows, 319, 320
 Copper and zinc sheathing for, 416
 Features of superiority to wood ships, 321, 383, 409, 413
 Fouling of bottoms, 415
 Foundering of, due to bulkheads being insufficient, 414
 Great durability of, 405, 407
 Iron sides with close frames in front of guns, 425
 Methods of framing, ordinary and special, 348, 359
 Penetrability of bottom, 315, 415
 Progress in construction and sizes, 380
 Skins of, 359
 Strains of, compared with those on a bridge, 367
- Isochronism of oscillations of ships in still water, 143, 151
- JET-PROPELLED vessels :—
 Steaming capabilities of, 532, 538
 Steerage of, 601, 656
- Jöessel rudders, 609
 Junks, Chinese, steerage of, 642
 Jury rudders, 649
- KEELS :—
 Method of scarphing in wood ships, 392
 Bilge (*see* Bilge-keels).
 Sliding, to diminish leeway, 489
- Keelsons :—
 Longitudinal strengtheners, 313, 347
 Method of scarphing, 392
- Knees, to beams : methods of fitting, 375
- LAP-JOINTS for iron plates and bars, 395
 Lateral resistance (*see* Resistance).
- Launches :—
 Of Royal Navy, diagonal planking of, 359
 Swift-steam : engines of, 523, 595
 „ „ position of screws in, 551
 „ „ remarkable speeds of, 593
- Launching : severe strains due to accidents in, 303, 312
- Leaks, rate of inflow of water through, 16
 „ „ usefulness of stoppers, 17
- Leeboards, use of, in shallow-draught vessels, 489
- Lee-helm, 599
- Leeway :—
 Angle of, 488
 Causes of, in ships sailing on a wind, 487
- Lloyd's Register, investigations on masting, 324
- Lloyd's rule for freeboard, 33
- Local strains (*see* Strains).
- Longitudinal :—
 Bending moments (*also, see* Bending), 299
 Bulkheads (*also, see* Bulkheads), 22
 Framing well adapted for iron ships, 313, 316, 348
 Oscillations (*also, see* Pitching), 252
 Strength (*see* Strength).
- Lurching : strains consequent upon, 307
- MAST and guy system, 314
- Masts :—
 Heights of, 511
 Number of, 505
 Proportion of sail carried by each of the, 506
 Rake of, 505
 Stations of, in sailing vessels, 505
 Supported by tripods in turret-ships, 324

- Materials for shipbuilding (*see* Wood, Iron, Steel).
- Megara*, Her Majesty's Ship: rate of corrosion of skin, and loss of, 408, 421
- Merchant ships:—
- Cellular construction of, 354
 - Check upon stowage of cargoes, 151, 156
 - Dead-weight tonnage for, 37, 60, 61, 64
 - Longitudinal bending moments experienced by, 299
 - Longitudinal strains on, 365
 - Nominal horse-power for engines of, 519 521
 - Parallelopipedon tonnage for, 65
 - Ratios of length to breadth, 464, 512, 580
 - Register tonnage for British, 46
 - Reserve of buoyancy, 11
 - Rules for freeboard, 33, 34
 - Rudder areas for, 633
 - Sailing capabilities of, 513
 - Stability under different conditions, 83, 85, 87
 - Steaming capabilities of, 515, 581, 595
 - Suez Canal tonnage for, 55, 58
 - Waterlogged vessels, 14
 - Weights of hull and carrying power, 385
- Metacentre for transverse inclinations:
- Approximate rules for estimating position of, 89, 90
 - Change of position due to entry of water into the interior, 105
 - Effect of metacentric height upon period of still-water oscillations, 141
 - Explanation of term, 77
 - Graphic representation of heights of, for different draughts, 91
 - Height above centre of gravity, 79, 83, 87
 - Motion during rolling, 129
- Metacentre for longitudinal inclinations:—
- Height above centre of gravity in various classes, 110
 - Use of, in estimating change of trim, 112
- Metals, rates of waste in sea-water, 419
- „ galvanic action on iron, 422
- Model experiments:—
- On efficiency of bilge-keels, 161, 165, 241
 - On resistances of ships, 471
- Moduli of elasticity:—
- Method for estimating, 386
 - Values for iron and timbers, 391
- Moment:—
- Righting, for transverse inclinations, 74, 118
 - Longitudinal bending, 284, 293, 299
 - Of inertia: explanation of term, 88, 136
 - „ its effect on rolling, 141
 - „ its effect on turning, 616
 - Of resistance of girders and ships to bending, 334, 338
 - To change trim, 112
 - Transverse bending, 304
- Motion of particles in screw-race, 545, 554
- Muntz metal for sheathing ships, 416, 418, 422
- NAVAL, brass, 418
- Neutral axis and neutral surface of beams, 331, 332
- OBSERVATIONS:—
- Of dimensions and periods of waves, 190, 194
 - Of rolling and pitching by:—
 - Automatic instruments, 275, 277
 - Batten instruments, 272
 - Photography, 275
 - Gyroscopic instruments, 267, 271
 - Pendulums, 262
 - Spirit-levels, 267, 271
 - Wheel-pendulums, 280
- Oscillations of ships (*see* Rolling, Pitching, and Dipping).
- PADDLE-WHEELS:—
- Principles of propulsion by, 538
 - Practical rules for, 540
 - Compared with screws, 561
 - „ water-jet propellers, 542
 - Disadvantages of, in sea-going steamers, 540
 - For manœuvring, 652
 - High speed obtained in ships driven by, 542
- Panting, produced by transverse compression on ends of ships, 306
- Pendulums:—
- Comparison of oscillations with those of ships, 132
 - Departure from isochronism with large angles of swing, 222
 - Discussion of motion of simple, and bar, 135

- Pendulums (*continued*):—
 Errors of, when used to measure rolling motion of ships, 264
 Use of, for measuring rolling and pitching, 262
 Use of, to illustrate behaviour of ships at sea, 225
 Wheel, 277, 280
- Periods of ocean waves:—
 Formulae for, 188
 Facts respecting, 199, 205, 207
 Methods of observing, 190
- Periods of pitching for ships, 252
 Rolling for ships in still water, 140
 Experiments to determine ditto, 151
- Pillars, contribution of to structural strength, 372
- Pitch of screw-propellers, 543
- Pitching and 'scending of ships:—
 Causes of, 253
 Governing conditions, 254
 Influence of form of bow and stern, and longitudinal distribution of weights, 257, 258
 Of low-ended ships, 259
 Periods for, 252
- Planking of wood ships (*see* Skins).
- Platforms:—
 As watertight partitions, 24
 Effect on maintenance of stability, 107
- Plating of iron ships (*see* Skins).
- Portage of ships (*see* Tonnage).
- Propellers:—
 Fundamental principles of, 530
 Mallory, 651, 652
 Paddle-wheels, 539
 Screws, 543
 Water-jet, 532
 Use of, for manœuvring, 652
- Propulsion:—
 By sails, 480
 By steam-power, 515
 Strains incidental to, 321, 323
- RACKING strains on ships:—
 Incidental to propulsion, 309, 312
 Mode of resisting, 356, 359
 Produced by rolling, 307
- Radius of gyration:—
 Defined, 136
 Effect upon period of pitching, 252
- Radius of gyration (*continued*):—
 Effect upon period of rolling, 141
 „ „ turning, 616
- Rake of masts, 505
 „ „ sternposts in yachts and ships, 39
- Ram attacks:—
 Best met by watertight subdivision, 29
 Construction of bows to meet strains of, 319
- Register tonnage:—
 Law of 1854 and approximate rules, 45, 47, 48
 Allowances to steamships, 49, 50
 Compared with displacement, 64
 (*Also see* Tonnage.)
- Repairs: relative cost in iron and wood ships, 412
- Reserve of buoyancy for various types of ships, 11
- Reserve of dynamical stability, 169
- Resistance of water (to advance of ships):—
 Augment of resistance due to screw-propeller, 544
 Early theories of, 433, 439
 Frictional, direct, and eddy-making, 435, 437, 438, 446, 460
 Largely independent of area of midship section, 470
 Model experiments on, 469
 Steam-line theory of, 440, 443
 Summary of results, 460
 Values of, for certain ships, 462
- Resistance, wave-making, 450, 455, 459
 To rolling of ships, 157, 159, 235
 To pitching and 'scending, 258
 To planes moving obliquely, 436
- Resistance, lateral:—
 To ships sailing on a wind, 489
 To turning of ships, 615
- Resistance of air to motion of ships, 477, 479
- Ribs (*see* Framing, Transverse).
- Riders, diagonal, for wood and composite ships, 357
- Rigging:—
 Air resistance to, 477, 479
 Spread of, 323
- River steamers, shallow-draught: special features of, 314, 360
- Rolling of ships in still water:—
 Coefficients of extinction, 159, 160

Rolling of ships in still water (*contd.*):—

- Dipping oscillations which accompany, 147, 149
 - Effect of changes in stiffness and distribution of weights, 141, 143
 - Effect of moment of inertia upon, 135, 141
 - „ resistance upon, 149, 151
 - Extinction of rolling, 153
 - Hypothetical case of unresisted rolling, 133
 - Instantaneous axis of rotation, 137, 138, 154
 - Isochronous rolling, 143
 - Oscillations resemble those of pendulums, 132
 - Periods of, 140
 - Resistance due to keels and bilge-keels, surface friction and surface disturbance, 158, 161, 163
 - Resistance due to internal free-water, 165, 167
 - Resistance in a seaway compared with resistance in still water, 160
 - Still-water experiments, 151, 155
- Rolling of ships among waves:—
- Behaviour of quick-moving ships, 217
 - „ slow-moving ships, 217
 - Dangers of synchronism of periods of ships and waves, 220, 227, 240
 - Early theories of, 211
 - Effects of changes in speed and course of ships, 228, 233
 - Governing conditions of, 211
 - Importance of ratio of wave period to period of ships, 216, 229, 231, 233
 - In a seaway with sail set, 246, 252
 - Methods of measuring angles of (*see* Observations of Rolling).
 - Motion of a small raft, 213, 217
 - Pendulum illustrations of, 225
 - Permanent rolling, 223
 - Phases of oscillation, 226
 - Records of, 225, 229
 - Safety due to increased period as angle of swing increases, 222
 - Safety or danger in a seaway, 240
 - Sketch of modern theory, 211, 218
 - Small rolling of vessels having very short periods, 234, 235
 - Steadiness secured by bilge-keels, 240, 241, 242

Rolling of ships among waves (*contd.*):—

- Steadying effect of sails, 251
 - „ „ a “confused sea,” 219
 - Strains on structure due to, 307
- Rudders:—
- Ordinary and balanced, 597, 606, 610
 - Auxiliary, 644, 647
 - Bow, 644
 - Centre of pressure of, 608
 - Considerations respecting areas of, 634, 637
 - Effective pressures on, 436, 608
 - Force required on tiller-end, 607
 - Gumpel's and Joëssel's, 609, 643
 - Lumley's, 643
 - Mallory, 651, 652
 - Rankine's and Schlick's, 642
 - Ruthven's counterbalancing weight applied to, 612
- Run of ships:—
- Connection between speed of ships and length of, 453
 - Effect of form upon rudder pressure, 601, 603

SAGGING:—

- Causes of, in still water, 285
- Astride wave hollows, 294
- Conditions of strain incidental to, 303, 336

Sailing vessels:—

- Arrangement of sail, 480, 499
- Areas and forms of rudders, 639, 641
- Area of sail in terms of wetted surface and displacement, 497
- Area of sail in terms of underdeck tonnage, 499
- Balance of sail, 492
- Base of sail, 505
- Centre of effort, position of, in, 502, 507
- Determination of aggregate sail area, 494, 499, 506
- Forms and proportions of, 513
- Heel of, under canvas, 75, 169, 310, 488, 509, 511
- High speeds of modern, 514
- Longitudinal distribution of sail, 501
- Plain sail for various styles of rig, 494, 499
- Propelling effect of wind on sails, 486
- Range of stability necessary for safety, 250
- Register tonnage of, 49

- Sailing vessels (*continued*):—
- Steadying action of sails, 251
 - Steerage of, 601
 - Stiffness, or sail-carrying power, 509
 - Strains due to propulsion, 321, 323
 - Under action of squalls of wind, 169
 - Vertical distribution of sail, 508
 - With more than three masts, 505
- Scarphs of various pieces in wood ships, 393
- 'Scending (*see* Pitching).
- Schooners:—
- Plain sail of, 494, 499
 - Centre of effort of, 504
 - Stations of masts, and base of sail, 505
- Screw-propellers:—
- Compared with paddle-wheels and water-jets, 535, 561
 - Conditions for maximum efficiency, 547
 - Diameter, pitch, disc-area and slip, 543
 - Experiments to determine best propellers for *Iris*, 557
 - for torpedo boats, 559
 - Effect of propeller race upon steerage, 605, 650
 - Large diameters not always advantageous, 547
 - Mallory, 651, 652
 - Manœuvring powers of single and twin, 653
 - Motion of particles in race, 545, 554
 - Necessity for free flow of water to, 550
 - Principles of action, 544
 - Upper blade does most work, 554
 - Use of twin and multiple, 549
 - Virtual increase of resistance produced by, 544
- Screws, steering: modes of fitting, 651
- Shallow-draught vessels:—
- Special structural arrangements, 314, 360
 - Difficulty of steering, 616
- Shearing strains on ships, unimportant, 283
- Sheer strakes, useful as longitudinal strengtheners, 345
- Shift of butts for planking and ribs of wood ships, 330, 368
- Ship-rig:—
- Plain sail of, 494
 - Stations of masts, 505
 - Position of centre of effort, 503
 - Base of sail, 505
- Simoom* target, experiments on, 425
- Skins of ships:—
- Arrangements in composite ships, 358
 - „ iron ships, 359
 - „ wood ships, 330, 355
 - Essential features of all classes, 326
 - Resistance to penetration of wood and iron, 315
- Slackness of sailing ships, 492
- Slip of paddle-wheels, 538
- „ screw-propellers, 543
- Speeds:—
- Of merchant steamers, 515, 581, 595
 - Of sailing ships, 513
 - Of unarmoured war-ships and ironclads, 516, 595
 - Lengths of entrance and run appropriate to, 453
- Spirit-levels, not trustworthy instruments for measuring rolling, 267, 271
- Stability, statical:—
- Atwood's formula for, 118
 - Amongst waves, reckoned from normal to effective slope, 212
 - Affected by shifting cargoes and free-water in hold, 102, 105
 - Construction and use of curves of, 118
 - Definition of, 76
 - Effect of adding or removing weights, 108
 - „ heaving motion upon, 186, 247
 - „ raising or lowering weights, 102
 - Less for mastless than for rigged ships, 172
 - Metacentric method of estimating, 77, 96
 - Of cigar and cylindrical forms, 97
 - Of ships partially waterborne, 115
 - Of submarine vessels, 97
 - Range of, required for safety, 250
- Stability, dynamical:—
- Definition of, 144
 - Effect of suddenly applied forces with reference to, 168
 - Mode of estimating, 147
 - Moseley's formula for, 146
 - Reserve of, 169
- Steadiness:—
- Assisted by deep bilge-keels, 241
 - „ sails, 251
 - Definition of, 77
 - Increased by lengthening still-water period of ships, 141, 218
 - Lessens transverse straining, 307

- Steamships :—
 Economical propulsion of, 463, 580
 Engine-power and speeds of various classes, 595
 Estimates of speed and engine-power, 562, 580
 Measures of engine-power, 518, 521
 Ordinary conditions of design, 517
 Progress in construction of, 515
 Register tonnage of, 45, 48
 Steerage of, 601
- Steam steering gear : advantages of, 613
- Steel, as a material for shipbuilding :—
 Features in which it is superior to iron, 426, 427
 Mild steel used in the Royal Navy, 429
 Objections to use of, 427
 Precautions against buckling and corrosion, 432
 Savings due to use of, 430
- Steerage of sailing and steamships, 601
- Steering-blades, use of, 649
- Steering-gear :—
 Manual, 611, 633
 Steam and hydraulic, 612
- Steering-screws, proposed use of, 651
- Steering trials :—
 Axis of rotation, 615, 618, 623
 Deductions from trials of steamers, 631, 653
 Drift angle, 621
 Initial motions of ships, 615, 618
 Preliminary or constructors' trials, 630
 Path described by the ship, 620
 "Pivoting point," 623
 "Tactical diameter" and "advance" of a ship, 631
- Steeve of bowsprits, 506
- Stern :—
 Strengthenings of, in wood screw-steamers, 322
 Effect of length and form upon resistance, 446, 449, 453, 459, 465
- Sternway, steerage of ships having, 605, 607
- Stiffness :—
 Definition of, 77
 Effect of form and stowage of ships upon, 81, 88
 Effect of variations in, upon periods of oscillation, 141
 Measured by metacentric height, 78
 Measure of power to carry sail, 509
- Stowage of weights or cargo :—
 Effect upon stability, 80, 102, 108
 „ longitudinal bending moments, 285, 289
 Proposal to check by rolling experiments, 156
- Strains experienced by ships :—
 Classification of principal, 283
 Incidental to propulsion by sails, 309
 „ „ steam, 311
- Strains :—
 Local, due to concentrated loads and supports, 312
 Due to collision, 317
 „ grounding, 314
 „ propulsion, 321
 On decks, 316
 Longitudinal bending :—
 In still water, 284
 „ when light, 290
 Among waves, 294, 301
 When vessel is heeled over, 300
 Measures of longitudinal, in mercantile and ironclad ships, 362, 365
 Racking or sheering, 308
 Transverse :—
 Ship aground, 304
 „ afloat, 306
 „ rolling in a seaway, 307
 Values (numerical), of bending, 299
- Stream-line theory of resistance, 440, 443
- Strength of shipbuilding materials (*see* Wood, Iron, and Steel).
- Strength of ships :—
 As influenced by proportions of length, breadth and depth, 339, 340
 Against local strains, 312, 342
 „ longitudinal bending, 327, 335
 „ transverse strains, 367
 Compared with that of a bridge, 367
 Considerations governing vertical and longitudinal distribution of the material, 341, 342
 General remarks on, 325
 Sometimes reduced by increasing the depth, 339
- Stringers :—
 On decks, valuable strengthenings, 345, 351, 373
 In hold, uses of, 314, 347, 373
- Subdivision, watertight (*see* Watertight Subdivision).

Submarine ships :—

Principles of construction, 11

Stability of, 97

Resistance of, 435, 441

Suez Canal : tonnage for dues, 55, 58

TABLES :—

Angles of heel as measured correctly and as given by pendulum clinometers, 266

Behaviour of ships at sea : observations of, 226, 227, 230, 231, 232, 242

Beaufoy's experiments on oblique resistances, 436

Calculation for centre of effort of sail, 502

,, of change of trim, 112, 115

Coal consumption, weights, &c., of marine engines of different types, 523

Coefficient :—

Of extinction, 159, 160

Of fineness, for displacement, 3

For tons per inch, 8

For moment of inertia of water-plane, 89

Comparative weights of iron and steel ships, 430

Corrosion and waste of metals in sea-water, 419

Displacement and B.O.M. tonnage, 42

Equivalent girder, calculation of, 337

Experimental determination of pressure of wind, 482

Froude's experiments on surface friction, 438

Galvanic action of metals on iron, 422

Illustrating economy of propulsion in large steamers, 589, 590

Illustrating increase of I.H.P. and sizes of ships, 381

Influence of bilge-keels on range and period of rolling, 163, 242

Influence of freeboard and beam on range of stability, 120

Influence of helm-angle in circle-turning, 636, 637

Lengths, speeds, periods, heights, &c., of ocean waves, 187, 188, 198, 199, 205, 207

Livadia compared with *Devastation*, *Alexandra*, and other ships, 585, 587, 588

Longitudinal bending moments in ships, 297, 299, 365

Metacentric heights of war-ships, 79

Modulus of elasticity of iron and timber, 391

Tables (*continued*) :—

Nominal and indicated horse-power, 520

Particulars :—

Of stability for *Captain* and *Monarch*, 170Of *Hercules* and long type of ironclad, 582

Of I.H.P. and M.M. speeds for various vessels, 595

Period of rolling as effected by arc of rolling, 222

Principal dimensions, &c. :—

Of war-ships, 124

Of merchant steamers, and results of inclining experiments, 82, 83, 127

Of sailing vessels and yachts, 86, 87, 129

Reduction of speed on circle, 629

Resistances :—

Of *Greyhound* and *Mer Kara*, 462

Of keels, bilge-keels, skin and wave-making, 161, 438

Sail, plain, with various styles of rig, 494, 499

Stability of ships at various angles (curves of stability), 120, 123, 125, 128

Stability of *Inflexible*, 126

Stations of masts, base of sail, &c., 505

Steadying action of water on armour deck of *Inflexible*, 167

Strengths and weights of iron and ship building timbers, 388, 390, 396

Tonnage, register, of merchant steamers, 48

Turning trials of *Thunderer*, 622,, ,, *Warrior* and *Hercules*, 635

Watertight compartments of ironclads, 27

Weights of hull and carrying power, 384, 385

Tensile strengths of wood and iron, 388, 390

Thames rule for yacht tonnage, 67

Thrust, indicated, 573

Timbers, shipbuilding :—

Compressive strengths, 390

Moduli of elasticity, 391

Tensile strengths and weights, 388, 390

(See also Wood.)

Tonnage of ships :—

Admiralty Commissions of, 1821, 1833, 41

Awning-decked ships, 55

Builders' old measurement, 38

Breadth for tonnage, 39

Tonnage of ships (*continued*):—

- Cellular-bottomed ships, how measured, 56
 Commission of 1849, 45
 „ 1881, 49, 53, 55, 60, 63, 66
 „ Danube, of 1876, 59, 60
 „ International, at Constantinople
 in 1873, 55
 Countries using Moorsom system, 59
 Danube rule, 52, 58
 Dead-weight tonnage, 37, 60, 61, 64
 „ cargo a ship can carry, 62
 Deck spaces, allowances for closed in, 54
 Displacement tonnage, 42, 43, 64, 65
 Earliest English law relating to “keels”
 or coal barges, 37
 Early laws, 37
 Freight tonnage, 67
 German rule, 52, 58
 Length of keel for tonnage, 39
 Merchant-shipping act of 1854, 45
 Moorsom system, 45
 New measurement of 1836, 41
 Origin of B.O.M. rule, 40
 Parallelopipedon tonnage, 65
 Parliamentary “tons weight of hull,” 43
 Register tonnage, 46
 Approximate rules for, 47, 48
 Gross, 46
 Nett, 47
 Of sailing ships, 49
 Of tugs, 51
 Suez Canal rules, 55, 58
 (*See also* Builders’ old measurement, displacement, &c.)
 Tons per inch immersion, 7
 Torpedo attacks: watertight subdivision a
 precaution against, 27
 Torpedo boats (*see* swift-steam launches).
 Transverse:—
 Bulkheads (*see* Bulkheads).
 Oscillations (*see* Rolling).
 Strains on ships afloat in still water, 306
 „ „ aground, 304
 „ „ in a seaway, 307
 „ „ under sail, 310
 Strength, 367
 Trim of ships:—
 Affected by entry of water into hold, 21
 Change of, in ships under sail, 309, 488
 „ when ships are turning, 630
 Estimates for change of, 112, 115
 How measured, 6
 Tripod supports to masts, 324
 Trochoidal theory for waves (*see* Waves).
 Twin screws:—
 First used in shallow-draught vessels, 549
 Good performances of, in deep-draught
 ships, 552
 Steering power of, 652
 (*See also* Propellers and Screw-propellers.)
 UNARMOURED war-ships:—
 Structural arrangements of, 344, 368, 371
 Speeds and dimensions of, 381, 516
 Sailing capabilities of, 499, 509
 Steaming capabilities of, 595
 Use of iron hulls for, 425
 Weights of hull for, 384, 385
 Useful displacement, 2, 384
 „ work of marine engines, 518
 Utilisation of ocean-wave power, 203
Volage class of Royal Navy, 372
Wampanoag class, United States navy:
 failure of, 382
 War-ships (*see* Ironclads and Unarmoured
 Ships).
 Water-chamber of *Inflexible*, 166, 243
 Water:—
 Weights per cubic foot of sea and river, 2, 9
 Draught of (*see* Draught).
 Not a perfect fluid, 434
 Velocity of inflow into damaged ship, 16
 Water ballast:—
 Methods of carrying, 29
 Effect upon stability, 107
 Water-jet propellers (*see* Jet Propellers).
 Waterlogged ships, 14
 Watertight subdivision:—
 Principles of, 17
 By decks and platforms, 24
 By longitudinal bulkheads, 22
 By transverse bulkheads, 19
 Imperfection of, in many merchant ships,
 413
 Maintenance of stability by, 104
 Of ironclads, 27
 Wave-line theory of resistance, 450
 Wave-making resistance of water:—
 To advance of ships:—
 Defined, 435
 Expenditure of force on, 444
 Governing conditions of, 450, 454, 459
 Importance of, at certain speeds, 460
 To rolling of ships, 149, 163

- Waves, deep-sea :—
 Advance of form, and motion of particles, 176, 178
 Construction of profiles, 177
 Dimensions corresponding to given forces of wind, 207
 Effective slope of, 213, 214, 279
 Exaggeration of heights, 195
 Fluid pressures in, 183
 Heaving motion produced by, 186, 247
 Internal structure, 180, 183
 Influence of ratio of wave period to still-water period of ship, 212, 216, 217, 229
 Maximum slopes, 185
 Methods of observing dimensions, 190, 194
 Ratios of heights to lengths, 196, 234
 Speed of wave compared with speed of wind, 205, 206, 208
 Summary of observed dimensions, 194, 207
 Superposition of series, 200
 Theoretical formulæ for, 187
 Utilisation of power, 208
 Viscosity of, 188
 Longitudinal strains of ships amongst, 294, 299
 Oscillations of ships amongst (*see* Pitching and Rolling).
 Transverse strains of ships amongst, 307
 Weights, per cubic foot :—
 Of iron, 387
 Of principal shipbuilding timbers, 388
 Of sea and river water, 2, 9
 Weights of hulls in various classes of ships, 384, 385
 Weights per indicated horse-power for various types of marine engines, 523
 Winds :—
 Apparent direction of, 486
 Condition of ships sailing on a, 486
 Connection between force of wind and size of wave, 205, 207
 Normal pressures, forces, and speeds of, 482
 Normal pressure affected by size and height of sail, 511
 Oblique action on sails, 483
 Outstripped by ice yachts, 491
 Wing-passages of ironclads, 27
- Wood, as a material for shipbuilding :—
 Causes of decay in, 403
 Compared with iron, 383
 Moduli of elasticity, 391
 Resistance of combinations to tensile and compressive strains, 391, 392
 Resistance to bending strains, 396
 Resistance to perforation, 315
 Tensile and compressive strengths of, 388, 390
- Wood ships :—
 Average durability of, 401
 Construction of ram-bows, 318
 Decks of, 345, 372
 Features in which inferior to iron or steel, 373, 383
 Methods of framing, 348, 368
 Metal sheathing on bottoms, 420
 Rapid decay of many, 402
 Skin planking of, 331, 332, 355
 Stern strengthenings of screw-steamers, 322
 Strength of bottoms, 315
- Work, mechanical :—
 Definition of, 144
 Done in inclining ships, 146
 „ putting rudder over, 609, 611
 Useful, of marine engines, 518
- Yachts :—
 Displacement tonnage, 69
 Forms and proportions of racing, 514
 Her Majesty's, special construction of, 358
 „ speed of, 542, 572
 Ice, speed of, 491
 Power to carry sail, 510
 Sail-spread of, 494, 498
 Time allowance on racing by New York rule, 70
 Tonnage measurement :—
 By Thames rule, 67
 By Corinthian rule, 69
 By sail-spread, 70
- Yards : bracing of, when sailing on a wind, 492
 Yawing : mode of measuring, 270
 Yawls : plain sail of, 494, 498
- Zinc sheathing for bottoms of wood and iron ships, 417, 419, 423
 Zinc protectors to copper sheathing, 417

UNIVERSITY OF CALIFORNIA LIBRARY
BERKELEY

Return to desk from which borrowed.
This book is DUE on the last date stamped below.

ENGINEERING LIBRARY

MAR 31 1954

OCT 30 1994

0 34185

836452

VM 45
W5
1809
Erwin P. ...

THE UNIVERSITY OF CALIFORNIA LIBRARY

U. C. BERKELEY LIBRARIES



C042235459

