

A  
0  
0  
1  
1  
8  
9  
4  
5  
4  
0

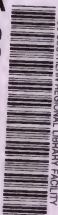

UC SOUTHERN REGIONAL LIBRARY FACILITY

# COMMON COMMODITIES AND INDUSTRIES

## OIL POWER

*Sydney H. North*



THE LIBRARY  
OF  
THE UNIVERSITY  
OF CALIFORNIA  
LOS ANGELES

GIFT OF  
U.S. Department of Commerce

LL  
my

g the  
erous  
given  
L OIL

more  
ands  
Where  
ng of  
ng is

Our expert Technical Engineers are at your service for free consultation on all matters relating to fuel oil.

---

WRITE FOR PARTICULARS AND LITERATURE

---

**SHELL-MEX LTD.**

*Fuel Oil Department*

Shell Corner, Kingsway, London, W.C.2

# The **RUSTON**

AIRLESS  
*Gold Starting*  
ATOMISER

## OIL ENGINE

Runs on the Cheapest Fuel Oil

(e.g. Furnace Oil of '95 spec. gravity),



Low Fuel Consumption Guaranteed  
(from '42 lbs. per B.H.P. hour).



Made in Sizes 15 to 340 B.H.P.

**RUSTON & HORNSBY LTD.**  
LINCOLN

# The PETROLEUM YEAR BOOK, 1922

EVERYONE connected with or interested in Oil will remember the cordiality with which the 1921 edition of this work (the first since 1914) was received. . . . The reason for its immediate popularity was obviously the quality and value of its contents. . . . The 1922 Edition will contain in addition to expansion of existing sections, three new branches of the Industry, namely—

## Refining, Lubricating Oil, and Finance

All the information and references have been revised and brought up to date. . . . This edition will achieve even greater popularity than its predecessor. . . .

---

ORDER YOUR COPY NOW

Price 10/6      Post free 11/3

---

THE ST. JAMES'S PRESS CO., LTD.

15 Henrietta Street, Covent Garden, W.C.2

---

# OIL ENGINEERING & FINANCE

A JOURNAL FOR THE PRODUCER, THE  
USER AND THE INVESTOR. 1/- WEEKLY

---

*The only Oil Journal conducted by Oil Men*

---

THIS is the first instance in Petroleum Journalism in which the important step has been taken of appointing an expert as Editor of the Section dealing with the subject in which he is a recognized authority. This policy ensures INDEPENDENT AND UNBIASED OPINIONS—ACCURATE AND UP-TO-DATE INFORMATION. Send 52s., and receive your copy each week post free for one year.

---

*Published each week on Saturday*

---

OIL ENGINEERING AND FINANCE

15 Henrietta Street, Covent Garden, W.C.2

## OIL POWER



THE ANGLO PERSIAN CO.'S OIL TANKER "BRITISH MARINER,"

*Frontispiece*

PITMAN'S COMMON COMMODITIES  
AND INDUSTRIES

# OIL POWER

BY  
SYDNEY H. NORTH  
ASSOC. INST. P.T.

EDITOR "OIL ENGINEERING AND FINANCE,"  
"PETROLEUM YEAR BOOK," ETC.



LONDON  
SIR ISAAC PITMAN & SONS, LTD.  
PARKER STREET, KINGSWAY, W.C.2  
BATH, MELBOURNE, TORONTO, NEW YORK

# PITMAN'S COMMON COMMODITIES AND INDUSTRIES SERIES

Each book in crown 8vo, illustrated, 3/- net

- TEA.** By A. IBBETSON  
**COFFEE.** By B. B. KEABLE  
**SUGAR.** By GEO. MARTINEAU  
**OILS.** By C. AINSWORTH MITCHELL  
**WHEAT.** By ANDREW MILLAR  
**RUBBER.** By C. BEADLE and H. P. STEVENS  
**IRON AND STEEL.** By C. HOOD  
**COPPER.** By H. K. PICARD  
**COAL.** By F. H. WILSON  
**TIMBER.** By W. BULLOCK  
**COTTON.** By R. J. PEAKE  
**SILK.** By LUTHER HOOPER  
**WOOL.** By J. A. HUNTER  
**LINEN.** By ALFRED S. MOORE  
**TOBACCO.** By A. E. TANNER  
**LEATHER.** By K. J. ADCOCK  
**KNITTED FABRICS.** By J. CHAMBERLAIN and J. H. QUILTER  
**CLAYS.** By ALFRED S. SEARLE  
**PAPER.** By HARRY A. MADDOX  
**SOAP.** By W. A. SIMMONS  
**THE MOTOR INDUSTRY.** By HORACE WYATT  
**GLASS.** By PERCIVAL MARSON  
**GUMS AND RESINS.** By E. J. PARRY  
**THE BOOT AND SHOE INDUSTRY.** By J. S. HARDING  
**GAS.** By W. H. Y. WEBBER  
**FURNITURE.** By H. E. BINSTED  
**COAL TAR.** By A. R. WARNES  
**PETROLEUM.** By A. LIDGETT  
**SALT.** By A. F. CALVERT  
**ZINC.** By T. E. LONES  
**PHOTOGRAPHY.** By WM. GAMBLE  
**ASBESTOS.** By A. L. SUMMERS  
**SILVER.** By BENJAMIN WHITE  
**CARPETS.** By REGINALD S. BRINTON  
**PAINTS AND VARNISHES.** By A. S. JENNINGS  
**CORDAGE AND CORDAGE HEMP.** By T. WOODHOUSE and P. KILGOUR  
**ACIDS AND ALKALIS.** By G. H. J. ADLAM  
**ELECTRICITY.** By R. E. NEALE  
**ALUMINIUM.** By G. MORTIMER  
**GOLD.** By BENJAMIN WHITE  
**BUTTER AND CHEESE.** By C. W. WALKER-TISDALE and JEAN JONES  
**THE BRITISH CORN TRADE.** By A. BARKER  
**LEAD.** By J. A. SMYTHE  
**ENGRAVING.** By T. W. LASCELLES  
**STONES AND QUARRIES.** By J. ALLEN HOWE  
**EXPLOSIVES.** By S. I. LEVY  
**THE CLOTHING INDUSTRY.** By B. W. POOLE  
**TELEGRAPHY, TELEPHONY, AND WIRELESS.** By J. POOLE  
**PERFUMERY.** By E. J. PARRY  
**THE ELECTRIC LAMP INDUSTRY.** By G. ARNCLIFFE PERCIVAL  
**ICE AND COLD STORAGE.** By B. H. SPRINGETT  
**GLOVES.** By B. E. ELLIS  
**JUTE.** By T. WOODHOUSE and P. KILGOUR  
**DRUGS IN COMMERCE.** By J. HUMPHREY  
**THE FILM INDUSTRY.** By DAVIDSON BOUGHEY  
**CYCLE INDUSTRY.** By W. GREW  
**SULPHUR.** By HAROLD A. AUDEN  
**TEXTILE BLEACHING.** By ALEC B. STEVEN  
**WINE.** By ANDRE L. SIMON  
**IRONFOUNDING.** By B. WHITELEY  
**COTTON SPINNING.** By A. S. WADE  
**ALCOHOL.** By C. SIMMONDS  
**CONCRETE AND REINFORCED CONCRETE.** By W. N. TWELVETREES  
**SPONGES.** By E. J. J. CRESSWELL  
**WALL PAPER.** By G. WHITELEY WARD  
**CLOCKS AND WATCHES.** By G. L. OVERTON  
**ANTHRACITE.** By A. L. SUMMERS  
**INCANDESCENT LIGHTING.** By S. I. LEVY  
**THE FISHING INDUSTRY.** By W. E. GIBBS  
**OIL FOR POWER PURPOSES.** By S. H. NORTH  
**STARCH.** By H. A. AUDEN  
**TALKING MACHINES.** By O. MITCHELL  
**NICKEL.** By B. H. WHITE  
**PLAYER PIANO.** By D. M. WILSON  
**INTERNAL COMBUSTION ENGINES.** By J. OKILL  
**DYES.** By A. J. HALL  
**MOTOR BOATS.** By F. STRICKLAND  
**VELVET.** By J. H. COOKE  
**THE STRAW HAT INDUSTRY.** By H. INWARDS  
**BRUSHES.** By W. KIDDIER  
**PATENT FUELS.** By J. A. GREENE and F. MOLLWO PERKIN  
**FURS.** By J. C. SACHS



TP  
355  
N810

## PREFACE

THE great expansion which has occurred in the adoption of oil for power production during the last few years appears to call for a work of small but comprehensive dimensions, which, while covering the scope of the subject in a general manner, does not aim at entering into great detail on its many and complicated aspects. It is believed, however, that the engineer, the ship-owner, and the industrial user of oil for power production, as well as for heating purposes, will find this modest work of considerable utility. The economic advantages of oil as compared with coal have been fairly widely traversed under the respective adaptations, and these will be an admirable guide to those who are doubtful on this point.

I have aimed at providing a concise treatise suitable both for the uninitiated and the experienced user, and have selected those data and descriptions which appear to me to fulfil this idea.

S. H. N.



# CONTENTS

CHAP.	PAGE
PREFACE . . . . .	V
I. INTRODUCTION . . . . .	1
II. THE HOME PRODUCTION OF FUEL OILS . . . . .	11
III. DIRECT OIL FIRING . . . . .	19
IV. OIL FUEL ON SHIPS . . . . .	42
V. OIL FUEL ON RAILWAYS . . . . .	53
VI. THE INTERNAL COMBUSTION ENGINE . . . . .	61
VII. THE MOTOR SHIP . . . . .	81
VIII. OILS FOR POWER PURPOSES . . . . .	88
IX. OIL FOR POWER AND HEATING IN INDUSTRY . . . . .	95
X. OIL STORAGE . . . . .	98
XI. DISTRIBUTION OF OIL . . . . .	106
APPENDIX . . . . .	114
INDEX . . . . .	120



# ILLUSTRATIONS

	PAGE
THE " BRITISH MARINER " . . . . .	<i>Frontispiece</i>
THE HOLDEN OIL FUEL BURNER . . . . .	21
THE KERMODE STEAM JET BURNER . . . . .	23
THE KERMODE PRESSURE JET BURNER . . . . .	25
THE KÖRTING BURNER . . . . .	27
THE ORDE BURNER. . . . .	28
THE RUSDEN AND EELES BURNER . . . . .	29
THE THOMPSON ATOMIZER . . . . .	30
THE THORNYCROFT OIL-FUEL SPRAYER . . . . .	31
THE WALLSEND BURNER . . . . .	33
THE WHITE LOW-PRESSURE BURNER . . . . .	35
THE J. SAMUEL WHITE BURNER . . . . .	37
BATTERY OF OIL-FIRED WATER-TUBE BOILERS . . . . .	39
STOKEHOLD OF THE " EMPRESS OF BRITAIN " UNDER COAL . . . . .	44
STOKEHOLD OF THE " EMPRESS OF BRITAIN " UNDER OIL . . . . .	45
R.M.S. " MAJESTIC " . . . . .	49
3,000 B.H.P. BURMEISTER AND WAIN MARINE ENGINE. . . . .	63
THE CAMELLAIRD-FULLAGAR ENGINE. . . . .	69
1,250 B.H.P. VICKERS HEAVY OIL ENGINE . . . . .	71
THE M.S. " YNGAREN " . . . . .	85
OIL STORAGE DEPOT OF BRITISH PETROLEUM CO., AVONMOUTH . . . . .	101
UNLOADING TANK STEAMER . . . . .	109



# OIL POWER

## CHAPTER I

### INTRODUCTION

SINCE the outbreak of the Great War the provision of cheap fuel supplies has been the chief problem of this country, and economic conditions have arisen which appear to have made the probability of a return to these somewhat remote. These conditions have, however, been responsible for the great extension which has occurred in the adoption of oil for power production and have brought the price of coal and oil into close approximation. Indeed, if all the economic advantages attainable by the use of oil be taken into consideration, the price of the latter is lower than that of coal when used in the internal combustion engine. This state of affairs has been an unprecedented opportunity for oil, and the great restriction in the supplies of coal compelled fuel users to resort to that description of fuel of which large and comparatively cheap supplies are available. The relative position of these two forms of fuel at that time was such that it constituted a serious problem for this country.

The superiority of oil over coal in many directions has been confirmed over and over again, and it may be asserted without fear of contradiction that oil must be counted as one of the chief factors in the success of our arms on land as well as on sea in the recent European conflict. Viewing the future in its broad aspects,

another assertion may be presented, with equal assurance, namely, that oil will play a very prominent part in the ultimate result of the commercial and industrial struggle which is now only in its initial stages.

The vital point on which this more extended development is dependent is that of supply. There have been, from time to time, assertions made casting doubts on the continuation and expansion of petroleum production. Many years ago, a similar attitude was adopted towards the matter of coal supply, and one recalls Jevons' well-known treatise on the coal question and the gloomy predictions he uttered in regard to the not far distant exhaustion of Great Britain's resources. He did not, however, allow any margin for the discovery of new seams and deposits, and precisely the same attitude is taken up by those who prophesy that, taking into consideration the progressive increase in consumption, the crude oil supply of the world will soon give way under the strain. All calculations, which must, of course, be of quite an arbitrary character, do not, and cannot, take into account the discovery and opening up of new deposits.

An important aspect of petroleum production is that the actual output is by no means representative of the potential production of a large number of the wells drilled and yielding. Especially is this the case in Mexico, Persia and one or two of the prolific American fields, the producing capacity of many of the wells in these fields being so great that transport facilities are not sufficiently extensive to handle the enormous quantities available, and the wells have to be capped and the oil drawn off as required. When one considers that many wells brought in, in Mexico and elsewhere, yield 100,000 and 200,000 barrels



a day, and that the provision of storage facilities alone for such huge quantities would involve an extraordinarily large capital expenditure, apart from the fact that existing transport facilities are not in any way equal to dealing with such quantities, it will be recognized that potential supply must be far ahead of actual supply, and that present output does not represent the amount of oil in sight. Moreover, there has occurred no period in oil history in which a shortage of supply has been known, at any rate, due to the failure of the sources of production. Whenever a shortage on the markets has happened, it has been attributable to factors other than production available. The progress of petroleum engineering has in itself conserved an enormous amount of oil which in previous years has been wasted, and, although wastage on the fields has been reduced, there are still many directions in which economies are necessary, and will, undoubtedly, be introduced.

Let us review briefly the fundamental factors in this question of supply. Economies to be effected subsequent to the raising of the oil are merely contributory ; the most important aspect of the matter is the duration and extension of the natural resources available. Oil as a commercial product has been in existence for little more than fifty years ; its recognition and application as a power producer has a history of only half that period. It is this latter development which has determined the great increase that has occurred in oilfield exploitation and supplies. During the past twenty years quite a number of new prolific sources of supply have been added to the list, and it may be advisable to set these out in some detail in order that a more stable perspective may be gained of the question as a whole. In the United States, the pioneer and premier of

petroleum-producing countries, we have the following remarkable record—

PRODUCTION IN 1,000 BARRELS

	1900.	1914.	1918.	1919.	1921.
Appalachian . . . . .	28,300	22,350	25,332	29,232	30,574
Lima-Indiana . . . . .	4,758	4,830	3,220	3,444	2,411
Illinois . . . . .	12,450	11,860	13,365	12,436	10,935
Oklahoma-Kansas	56,300	120,500	148,708	115,987	} 256,085
Central and North Texas . . . . .	12,900	12,340	17,280	67,419	
North Louisiana . . . . .	8,600	9,850	13,304	13,575	
Gulf Coast . . . . .	14,647	15,340	24,207	20,568	
Rocky Mountain . . . . .	1,300	9,430	12,808	13,584	
California . . . . .	4,524	84,650	97,531	101,564	114,709

It is quite true that the Pennsylvania and Ohio fields are coming near the point of exhaustion, but this fact throws a powerful light on Nature's capability of more than recouping her failure in some directions by a most prodigal supply in others. Outside America, there are the widely scattered examples of Borneo, Mexico, Persia and Egypt. The development of the Borneo fields is one of the romances of the petroleum industry and Mexico follows it very closely for its astonishingly rapid rise in so short a period. Here are the figures—

	<i>Thous. Brls. 1900.</i>	<i>Thous. Brls. 1920.</i>	<i>Thous. Brls. 1921.</i>
Borneo . . . . .	Nil	10,490·4	11,549
Mexico . . . . .	Nil	163,540	195,064
Persia . . . . .	Nil	12,352·7	14,600 <sup>1</sup>
Egypt . . . . .	Nil	1,042	1,181

These tables deal with only those fields which have come into prominent production during the last twenty

<sup>1</sup> Estimated

years, and do not take into account the established sources of supply which have, in many cases, shown considerable expansion and are capable of being more widely extended. In addition to these, however, there are known deposits of unestimated yield which have either been but slightly tapped or have, up to the present, remained untouched. Among these are the vast oil-bearing tracts located in the South American Republics ; the unexploited districts of Russia and the extension of those already opened up ; the numerous undeveloped resources of the British Empire, of Mesopotamia, of China, of Madagascar, and Algeria, and in addition there still exist as yet untouched the bituminous shale deposits of France, Serbia, Spain, New South Wales, New Brunswick, Nova Scotia, etc.

In the year 1910 the world's crude oil production amounted, in round figures, to 327,500,000 barrels ; in 1921 the output had increased to approximately 760,000,000 barrels, showing, as between these dates, an advance of over 130 per cent. The figure for the latter year must, of necessity, be approximate, inasmuch as it is possible only to include Russia, Rumania and Galicia as estimates. A table is given on page 6 of the crude production of the world's oilfields for the years 1910 to 1921 (1 = 1,000 barrels).

It is interesting to note that of the total increase between the years 1910 and 1917 more than two-thirds were derived from the four new large sources of supply, which were brought into substantial production during the last twenty years. At the same time, the European fields were practically eliminated from the world's supply though their capacity of output, which was being more thoroughly exploited before the war, remains, as far as one knows, of the same extent. Another feature which has an important bearing on the fuel question is

	1910.	1919.	1920.	1921.
United States . . . . .	209,557	377,719	443,402	469,639
Russia . . . . .	70,336·6	46,800 <sup>1</sup>	25,430	28,500
Rumania . . . . .	9,724	6,440	7,435	8,347
Galicia [Poland]	12,673·7	5,800	5,606	3,665
Dutch East Indies . . . . .	10,844	18,300	17,529	18,000
Mexico . . . . .	3,333	92,000	183,540	195,064
India . . . . .	6,138	5,712	7,500	6,864
Egypt . . . . .	—	3,340	1,042	1,181
Trinidad . . . . .	214	2,600	1,042	1,181
Peru . . . . .	1,330	2,875	2,083	2,354
Persia . . . . .	—	7,000 <sup>1</sup>	12,352	14,600
Japan . . . . .	1,923·7	3,700	2,816·7	3,568
Other countries . . . . .	1,500	2,500	2,140	2,600
	<u>327,474</u>	<u>574,786</u>	<u>694,854</u>	<u>759,030</u>

that the character of the oil obtained from the large areas brought into production during the last twenty years is such that the yield of fuel oil is higher than that of the older fields. This is true more especially of the Californian and Mexican petroleums, which, being heavy oils and yielding a small proportion of the lighter products are very suitable for use in oil fuel apparatus and engines of the Diesel type and those designed especially to consume the heavier oils. The table appended indicates the petroleums providing the largest quantities of fuel oil per cent together with the totals available from the fields referred to—

	Per cent in volume.	Quantities avail- able from total output of 1921. Mill. brls.
California (average) . . . . .	65	74·6
Mexico . . . . .	70	136·5
Texas (including Gulf Coast) . . . . .	57	58·7
D.E. Indies . . . . .	40	7
Oklahoma-Kansas . . . . .	50	75

<sup>1</sup> Estimated

Thus from these fields alone the supply of fuel oil amounts to a total of 250,000,000 barrels or, approximately, 34,444,000 tons, a provision which is being extensively increased every year. These figures can only be estimates, though they give some idea of the available supply, while another 50,000,000 barrels, or about 7,000,000 tons, may be relied on from the fields not included in the above table. The oils from the fields detailed above are also those possessing the highest calorific value among the world's petroleums, a feature shown in the following table—

	<i>Calories.</i>	<i>B.T.U.</i>
California . . . . .	10,400	18,800
Mexico . . . . .	10,500	18,900
Texas . . . . .	10,700	19,242
Borneo . . . . .	10,460	18,831
Oklahoma . . . . .	10,800	19,400

Apart from the advantages of oil over coal in numerous directions, its calorific value is considerably higher. For instance, the best South Wales steam coal yields only 15,000 B.T.U's. per lb., Yorkshire coal 14,500, while other English coal of high grade yields only from 11,000 to 14,000 B.T.U's.

The crude petroleums obtained from the various fields differ considerably in character. These may be divided into two main categories—those having a paraffin base and those having an asphalt base. The former are the more valuable crude oils, possessing a larger proportion of light products; the latter yielding smaller quantities of these and a large quantity of heavy oils. The crude oils, from which a high percentage of light products are obtainable, are worked for securing these, their market value being greater and more profitable to the producer. These paraffin crude oils found

chiefly in the Appalachian and Mid-West fields of America, in Rumania, Galacia, Russia, and one or two other sources, are so rich in the more valuable products that the residue suitable for fuel oil is not sufficiently plentiful to be regarded in the refinery. It is, therefore, to the younger fields that we must turn for supplementing our supplies of fuel oils suitable for burning under boilers and for the Diesel type of engine. Outside America, which provides nearly 70 per cent of the crude oil of the world to-day, there are few prolific deposits the crude oil of which is capable of yielding large quantities of the lighter products. I am not speaking of the percentage yield of the oil itself, but of aggregate quantities. The deposits of Pennsylvania, Ohio and West Virginia, the richest oils of America, are all indicating the approach of exhaustion. The output of Pennsylvania in 1919 was little more than one fourth of the figure representing production in 1882; Ohio shows a decline to one third of its output of 1896; West Virginia, a decline to approximately half of its output in 1900, while in each field the decline is marked by a consistent downward gradient. On the other hand, the fields which register an upward movement such as California, Texas, Oklahoma, Kansas, yield crude oils from which a comparatively small proportion of lighter products are obtainable. The crudes of Mexico and Persia, the two younger and most prolific fields, fall under a similar category; they are essentially fuel oil petroleums. When, therefore, we hear alarmist reports of the possible shortage of supply, it is apparent that no discrimination has been exercised in studying the question, for a comprehensive survey of the position, of the unexplored and unexploited lands, of the possible extension of developed areas as well as of the potentialities of fields now producing, leads one to the belief that the oil

deposits of the world have not as yet reached anything like their capacity of output. If these critics asserted that the deposits of crude, from which a large percentage of the lighter products were obtainable, were showing signs of exhaustion, they would have a certain amount of evidence on their side ; but to bulk the whole oil resources of the world together, irrespective of description, not only is erroneous but displays an entire ignorance of the subject. For after all it is the deposits of crude oil which are the essential factor, and these are still in their infancy from the production point of view. An illuminating fact on this aspect of the matter is that of the oil lands of Mexico, which cover an area of 230,000 square miles, only 800 square miles having been exploited at the present time. Similar conditions prevail in other fields, though not in many cases to the same degree, but it may be asserted that there exists as good ground for a belief in the unreliability of coal supplies as for the uncertainty of oil supplies. It may also be contended that the wastage accompanying the working and distribution, apart from the actual burning under boilers, of the former is equally as great as the latter. Furthermore, the methods of winning, raising and transport of petroleum appear to offer greater possibilities of economy than those associated with coal, and many improvements have been introduced during the last ten or fifteen years which have undoubtedly conserved the oil resources of the world to a considerable extent. This movement is still in progress and methods will continue to improve, eliminating still further the wastage attending the production, transport and storage of oil.

A highly important experiment has been carried out in the oil fields of Pechelbronn, which may open up great possibilities in the direction of increasing the supplies

of the world's oil resources. The process consists of driving galleries into an oil bed, which has been exhausted by borings. The originator of this, M. Paul de Chambrier, contends that the quantity of oil remaining in the bed after exhaustion by boring is still so large that it is a waste of this material not to endeavour to extract it by more modern means. This is probably true, and was indeed, proved at Pechelbronn, but whether this method can be applied in other fields has been questioned by many high authorities. If, however, it could be applied successfully, the value of such a process would be inestimable.



## CHAPTER II

### THE HOME PRODUCTION OF FUEL OILS

A STUDY of the fuel question of this country would not be complete did it not embrace a review of the possibilities of producing petroleum within its own borders. The conditions which now govern the supply of fuel in the United Kingdom, and the increasing use of oil for power purposes, bring coal and oil into vital juxtaposition. The prices of these two fuels have, indeed, drawn so close together, that there is only one factor which stands out in favour of coal, and that is a geographical one. The fact that the sources of our oil supplies are thousands of miles distant, from which we may be, by some unforeseen occurrence, cut off, and that we have at our doors large quantities of solid fuel, deters many fuel users from resorting to the former, though far more efficient and economical in character. It is here that the two aspects of the subject join issue. The first element in the argument is that both coal and oil possess the same ultimate composition, as will be seen from the following figures—

	C.	H.	O.	S.	Ash.	Moisture.
COAL—						
Welsh . . .	83·8	4·8	1·0	1·4	4·1	4·9
Newcastle . .	82·1	4·3	1·3	1·2	5·7	3·8
OIL—						
Russian . . .	87·4	12·5	·1	—	—	—
Texas . . .	85·66	11·03	3·31	—	—	—

It will be noticed that coal contains items which depreciate its value as a heat raising mineral, and that these are absent from oil. It is apparent, therefore,

that the liquid form of fuel is the more efficient and, therefore, the more economical. The present industrial conditions demand those auxiliaries which provide the greatest efficiency, the indicator thus points to fuel in its liquid form. Now this country does not possess natural oil resources, but it does, undoubtedly, possess vast quantities of mineral substances from which oil can be distilled. The most extensive field in this direction is that of coal. The valuable products which it is capable of yielding are now being entirely wasted by the method of burning employed.

It has long been recognized in the scientific world that coal in its natural state is a costly and very inefficient power producer, and combined with its recent high price, occupied a most unsatisfactory position compared with oil. It is, therefore, impossible to consider the fuel question of this country without traversing the possibilities of oil production from this and other sources.

The oil requirements of this country, gauged by importations, stood in 1921 at the following figures: (1 = 1,000)—

	<i>Gallons.</i>
Crude oil . . . . .	99,592
Lamp oil . . . . .	149,348
Motor spirit . . . . .	251,098
Lubricating oil . . . . .	50,966
Gas oil . . . . .	76,826
Fuel oil . . . . .	533,132
Other descriptions . . . . .	86·5
	<hr style="width: 100%; border: 0.5px solid black;"/>
	1,161,048·5
	<hr style="width: 100%; border: 0.5px solid black;"/>

Approximately therefore we require over 1,000,000,000 gallons or, roughly, 3,500,000 tons of different oils annually, a quantity which will certainly increase largely every year.

It is contended in some quarters that we should

make a considerable contribution to these requirements by treating coal and other carbonaceous substances, of which we possess extensive deposits in the United Kingdom, by the low temperature distillation process, by which heavy and light oils could be extracted in fairly large quantities. The contention is undoubtedly a rational one, and would go a long way towards solving the fuel problem of the country. Important progress has been made in perfecting the process of low temperature distillation, and it is believed that the latest type of retort now in use is one which will make commercial success assured.

It is obvious that the coal mines of this country must be worked and coal produced; it is also now clearly recognized that the mineral contains large quantities of valuable products, among these oil, which must be conserved. The present methods of burning coal must be revolutionized, in other words, coal must be made to yield a far higher ratio of efficiency than it has done hitherto. By present methods of use for power and heat production, not only is its efficiency largely destroyed but the valuable by-products are uselessly dissipated.

During the critical times of the Great War, when oil supplies were of such extreme urgency, a petroleum research department was formed for the purpose of ascertaining the extent and character of the mineral deposits of this country from which oil could be obtained by distillation. Writing on this subject in the *Petroleum Year Book*, Mr. E. H. Cunningham Craig states that "Research quickly proved that the most hopeful and the most rapidly realizable method of obtaining oil lies in the retorting of torbanites, cannel and colliery waste."

The geological staff of the department visited practically every colliery in the country, and it was found

that the quantity of valuable material at present neglected, whether mined and treated as waste or left in the mines, is enormous. In addition much valuable information was obtained about unworked or abandoned areas, where valuable retortable material exists. In some cases it was necessary to descend the mines, but in most cases a study of the belts and waste heaps, and the cross-examination of managers, foremen and miners was sufficient. Conservative estimates of available supplies were collected from each district, and material selected for detailed examination. The detailed work consisted of microscopic examination, which resulted in the discovery of many important points, and enabled a classification of all retortable materials to be made. Then came chemical analyses, and finally large-scale retorting tests were made of several tons of each deposit selected, to ascertain what conditions of temperature, etc., would give the best results in each case. The results were tabulated and a complete record kept.

“ This work resulted in the discovery that torbanites are much more common than had been previously supposed, while the various qualities of gas, splint and cannel coals, as well as other valuable materials known by local names such as ‘batts,’ ‘jacks,’ ‘gees,’ ‘rattle-jacks,’ ‘rums,’ etc., were recognized, classified and their potential yields of oil determined. It was recognized from the first that great central retorting stations would be required dealing with at least 1,000 tons per day, but as a war emergency measure, at the request of the production department, small stations at the collieries, capable of dealing with 100 tons per day, were suggested. For the larger stations, of which twelve or thirteen could be established, approximate sites were considered, with reference to

facilities for transport and the minimum expense in assembling sufficient material of approximately the same grade. It was soon made clear that each different material would require slightly different treatment.'

The average production of oil from the material selected for treatment was from 33 to 35 gallons of crude distillate per ton, and from this distillate at least 10 per cent of petrol can be obtained by refining.

The Committee of the Institution of Petroleum Technologists took up the research where the department left off, and concentrated chiefly upon the treatment of canneloid material and colliery waste, including "smalls," but excluding domestic and industrial coal. These latter were not considered, since it did not appear that the country was prepared to give up the uneconomic open coal fire.

The discovery of hitherto unknown supplies of retortable material continued, and the examination and preliminary testing proceeded. It was soon evident that a compromise between the recovery of a maximum quantity of oil and the utilization otherwise of the raw material would give the best commercial results. Thus it does not pay to attempt to obtain any one product at the expense of all others. Complete extraction of oil-content leaves the solid residue too low in volatile matter to give the best results either in a gas-producer or a briquette works. The attempt to obtain a maximum yield of gas results in a useless residue and a poorer quantity of oil.

Material high in ash (such as torbanite) yields the best oil at the lowest temperature, and probably also the largest quantity of oil a ton.

The results obtained on the distillation of various descriptions of minerals quoted by the same authority, may be given as indicating, not only the possibility of

securing valuable oil products, but the great loss which is entailed in burning coal in its natural state.

PRODUCTS FROM COAL CARBONIZED AT LOW TEMPERATURES

	Galls. of Crude Oil per ton Carbonized	Sulphate of Ammonia. lbs.	Oil yielded on fractionization.		
			Distilled up to 150° galls.	Fuel Oil galls.	Paraffin Wax lbs.
Yorkshire (Washed smalls) . . . . .	17.5	22	3	11	8
Yorkshire Cannel . . . . .	70	3.2 (to 170°)	7.4	49.3	—
Slack from Bituminous Yorkshire Coal . . . . .	24	22	2.8	12	—
Scotch Cannel . . . . .	37	-(to 150°)	1	22	--

The percentages of products obtainable from the crude tar oil distilled will give an idea of the value of these—

PERCENTAGES OF OILS DISTILLED FROM VARIOUS COALS

*Boghead Cannel Oil.*

	Sp. gr. .916	Water .5%
Distilling up to 170° C.	8 per cent	
170°-230°	10	"
230°-270°	13	" Sp. gr. .832
270°-350°	38	" " .886
Pitch	30.5	"
Tar acids average 9% of the total distillate.		

*Another Oil.*

	Sp. gr. .940	Water 7%
Distilling up to 170° C.	6.5 per cent	
170°-230°	8	"
230°-270°	9.5	"
270°-350°	27	"
Tar acids average 7% of the total distillate.		

The residual solid fuel in the low temperature process is generally of such a character that, though it has been deprived of the products which are given off in the form of smoke, etc., under present methods of burning, its calorific value is higher and its rate of consumption less than the original coal. That is to say, this residual fuel

is far superior to gasworks' coke, and can be readily lighted and burned in an open grate.

It is clear, therefore, that we possess in this country extensive mineral deposits from which can be readily secured large supplies of fuel oil and motor spirit. Coal does not, however, exhaust these, for there are in different parts of the country practically unlimited deposits of shales which could be made to yield, by a similar process, even larger supplies of oil, provided these were deprived of their sulphur. Many attempts have been made to discover a means of desulphurizing these oils, and although it has been claimed that a satisfactory process has been found, it has not yet been carried out satisfactorily on a commercial scale.

The principal deposits of oil shale in England occur in the Kimmeridge clay of Dorsetshire. These measures pass in a north-easterly direction into Norfolk, and extend to the east into Sussex and Kent. A considerable amount of exploratory and experimental work has been done in connection with this material, but so far with no commercial success, since the oil obtained is characterized by a high sulphur content. The nitrogen percentage is also very high.

The outcrop of the Kimmeridge shales in Norfolk provide an almost unlimited deposit of mineral. The upper series of shales form a close-grained rock, dark-brown in colour, with distinct planes of fracture. The underlying shale is a greyish-blue rock. These shales differ from Boghead and Torbanites, and more closely resemble the Scotch shales. Bulk tests show a yield of 40 gallons of oil per ton of shale and 66 lb. of sulphate of ammonia; the sulphur content is 6.4.

The oil-shales of Jurassic age discovered in the Island of Skye and Ramsay resemble the Norfolk Kimmeridge shales very closely.

The following percentage results obtained from large tests of shales are of interest—

Water.	Fixed Carbon.	SHALES.		Volatile in residue.	Crude Oil.	Sp. Gr. of Oil.
		Ash.	Volatile.			
%	%	%	%	%	Galls. per ton.	
14·6	14·4	56·7	28·9	2·9	23·98	1·026
7·2	15·1	49·0	35·9	2·0	36·55	1·015
11·8	12·9	48·0	39·1	1·1	35·8	·996
6·4	16·8	47·0	36·2	2·8	34·37	1·005
2·1	9·0	75·0	16·0	2·1	16·7	·856
25·2	9·3	72·9	17·8	2·8	9·63	1·009
27·4	8·4	76·3	15·3	2·4	12·67	·995
1·9	38·5	25·5	36·0	3·6	40·97	·947
2·3	38·5	28·0	33·5	4·8	34·9	·946

It is, therefore, from this point of view that the issue between coal and natural liquid petroleum is joined, and I see no reason why this country should not soon become an oil producer on a large scale.



## CHAPTER III

### DIRECT OIL FIRING

THE use of oil for the production of power was first initiated in Russia and originated in the brain of a mechanic employed in the first refinery in that country. In those early days, when the market for oil was of a very restricted character, the intermediate oils were practically the only descriptions produced, the heavy residues and the very light oils being discarded as waste. On the suggestion of this man the question of burning the heavier oils as fuel was taken up and the first oil burner was invented by him in 1861. He adopted various contrivances, but ultimately settled on an apparatus consisting of a series of grates or griddles, over which the liquid trickled and burnt. A patent was taken out by him for this device in 1867 and many firms used it, but gave it up when improved appliances were available.

In 1862 attention was directed in America towards the application of petroleum for heating and power. Another early method of burning the oil was by means of a pan or step over which the oil flowed and was ignited, while almost at the same time Shaw and Linton patented in America a furnace in which the fuel was conveyed into the interior in a gaseous state, the oil being previously heated and made to give off its lighter oils, which were subsequently consumed inside the furnace. Undoubtedly, this was a more advanced idea than that of burning the oil in its natural state openly in the bottom of the hearth. In the year following (1863) the first spray furnace was introduced into

America by a Mr. Brydges Adams for use on locomotives ; yet, in spite of this great improvement and the most perfect combustion of the fuel obtained, a year later Richardson introduced into England what was known as an oozing furnace. In this furnace, which was experimented with by the inventor in conjunction with the Admiralty, the bottom was lined with ordinary burned slack lime, spread evenly at the top, but with a number of small vaultings at the bottom of the layer. The oil entered these spaces from tanks, and penetrating the lime, which acted as a sort of wick, became ignited and was consumed. Later experiments were made with this method of burning the oil, with the result that a commission appointed by the Admiralty reported very favourably thereon, though the system was not adopted, owing to the prohibitive price of liquid fuel. The experiments, however, served to show that unmixed oils had a greater evaporative power than mixed, the latter in this case consisting of tar oil and shale oil, and, in one instance, tar, shale, and American crude oils.

It is unnecessary to enter into more detail in regard to the early development of the oil fuel burner, as the instances given lead us to the stage where the main lines have been laid which led up to the evolution of the present types of burner. The year 1883, however, marked the opening of a new era, initiated by the invention of Sir (then Mr.) James Holden, of the burner known by his name. As Locomotive Superintendent of the Great Eastern Railway he turned his attention to the use of liquid fuel for steam raising for locomotives, with the object of using the waste tar obtained from the oil gas works at Stratford. His purpose was to devise one which would be independent of any extra brickwork, and also should be available for use in conjunction with

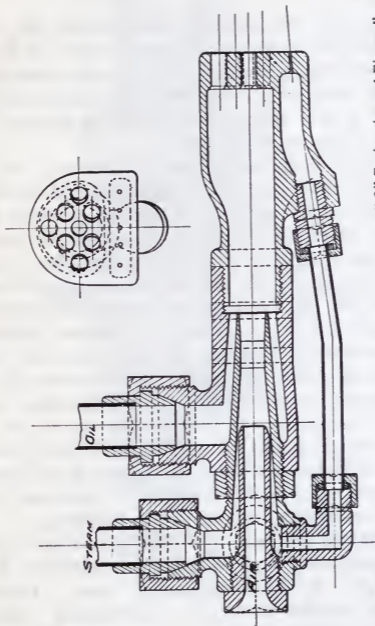

“Oil Engineering and Finance”

FIG. 1

*Loaned by*

coal, and he ultimately introduced a system by which it became possible to fire a boiler either with coal alone, as ordinarily used, with coal and oil combined, or with oil alone.

In the early days of oil-firing experience, Mr. Holden discovered that ordinary jet burners could not be relied on to spray efficiently enough oil for the generation of sufficient steam without the brick arrangements objected to, and a new burner was therefore devised which included many improvements.

The chief methods adopted in burning oil under boilers are : mixing oil with a steam jet and heating and atomizing it by means of a burner of small design through which the oil is forced, under low pressure, by the use of a pump or by gravitation from a settling tank ; compressed air burners, which act on the same principle but which involve the use of air compressors, thus rendering the installation somewhat complicated and expensive and reducing reliability ; and the pressure jet system, which eliminates the necessity of using either steam or compressed air for atomizing the fuel. Since the extensive use of oil fuel during the war, many minor improvements have been introduced into the various oil fuel systems, and, for the benefit of the student of the subject, a brief description<sup>1</sup> is presented of each of the chief systems now generally adopted.

**The Holden Burner.** This burner consists primarily of a coned body into which oil is admitted through a specially designed regulating valve. Inside the body an annular steam jet is introduced. This possesses a central passage for assisting in the supply of air and for enabling a wire to be passed through the burner without shutting off either oil or steam. Immediately behind the nozzle a hollow ring is attached,

<sup>1</sup> Specification from the *Petroleum Year Book*.

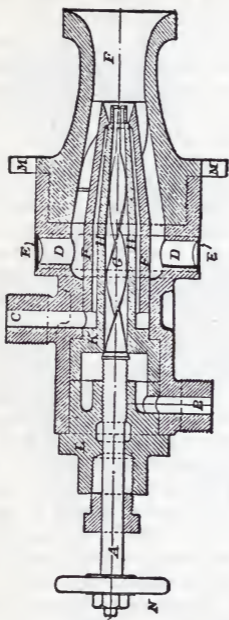

FIG. 2  
KERMODE STEAM JET

and to this steam is admitted and allowed to escape from six very fine jet holes. Another requirement fulfilled by this ring is that the jets induce a strong current of atmospheric air, which is carried forward and mixed with the spray as it emerges from the nozzle, ensuring complete combustion. The valve used for regulating the flow of the oil fuel is of special construction, and in this burner a small reservoir of oil is formed by the body of the valve, a tube with a slit in it being moved up and down inside. Very fine adjustments in the flow of oil are possible with this valve.

**The Kermode Steam-Jet Burner.** The oil enters the burner B (Fig. 2), and is given a whirling motion by the long special stem of the valve spindle G, the quantity of oil being governed by the hand-wheel N at the end of spindle A. The steam enters at C round the hollow cone H and passes through slots in the cylindrical portion of this cone, where it fits the inside of the hollow air-cone F. This air-cone is fitted with special guides, and the air is drawn past these guides through the opening D by the inductive action of the steam. The amount of air may be regulated by means of the movable perforated strap E. The part marked F can be screwed in or out as a whole, being turned by the spider M. When moved it carries with it the cone F, and in so doing regulates the space between this and the oil-cone H for the escape of the steam.

**The "Kermode" Pressure-Jet Burner.** The oil enters the burner (Fig. 3) through the channel A, and passes between the outer wall of the burner D and the inner cylinder B, which abuts against the cap nut E. The end of the cylinder B is a true fit for the outer body D at the end where it abuts against the cap. A series of grooves are cut in the plug end of B parallel to the centre line of the burner, and similar grooves are cut

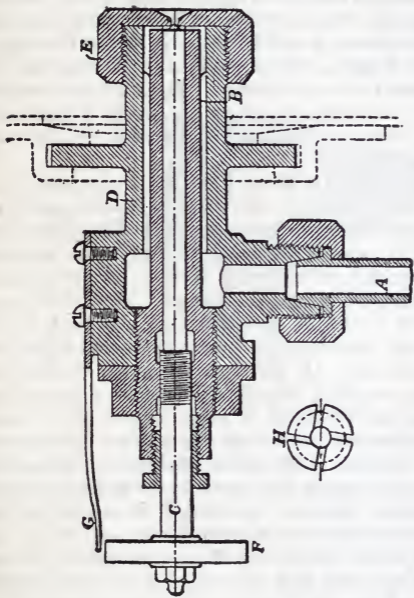

FIG. 3  
THE KERMODE PRESSURE-JET BURNER

in the face of the plug B at right angles to the axis of the burner. These grooves are shown in sketch H, and are tangential to the cone end of the spindle C, which serves to contract or enlarge the opening through the cap nut E. The movement of the spindle is indicated on the graduated wheel F by being forced through a restricted opening with a rotary motion, and the oil is pulverized very completely. The fixed pointer, G, indicates the degree to which the wheel F has been rotated, either to increase or decrease the opening through the cap nut.

**Kermode's Air-Jet Burner.** In this burner the oil is sprayed by means of air, at from half-a-pound to four pounds pressure. Furnaces for industrial purposes will sometimes work satisfactorily with an air pressure of half-a-pound, on the other hand, in extreme cases, four pounds pressure may be required. The oil entering the burner is met by air passing in, and both travel on together, and there is a complete commingling of the air and oil. All the elements of the combustion are under complete control. The oil as it passes the nozzle beyond the valve is swept forward by a sharp current of air which envelops the nozzle; this current can be regulated with great exactitude. A further compressed air supply is given where combustion is about to commence, while a third supply is caused by the induction of the flame or by the draught.

By the use of this system 83 per cent of the calorific value of the fuel used is recovered in actual work. Less than 2 per cent of steam is used to drive the air compressing plant, and if this is condensed no fresh water is lost. For industrial operations the air compressor is electrically driven when current is available. In some cases it may be belt-driven from an existing power shaft.



**The Korting Burner.** This burner is of the pressure-jet type. The oil is first heated to a temperature of  $130^{\circ}$  C., and is then forced through the burner under a pressure of 50 lbs. to the sq. in. The oil flows into a chamber feeding the jet, which is fixed to a spindle carrying a special screw. The oil is forced down this spiral, acquiring a vortex movement which sprays it out of the jet in a finely divided state and of sufficient

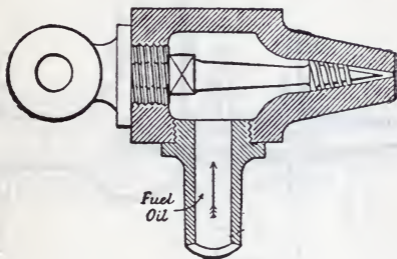

FIG. 4  
THE KORTING BURNER

intensity to make it fly into spray by centrifugal force immediately it issues from the nozzle. (Fig. 4.)

**The Orde Steam-Jet Burner.** In the improved pattern of this burner the form and disposition of the nozzle are slightly changed; there is also the addition of a branch (*t*) for the purpose of utilizing steam pressure to blow through the oil service pipe after closing down, so that any obstruction or deposit may be cleared out. As in the earlier design, the annular steam jet in this burner is controlled by a rotary movement of the hollow valve (*v*) and that of the oil—which is preferably heated and supplied under pressure—is controlled in a similar manner by a movement of the needle valve (*n*). (Fig. 5.)

**The Rusden-Eeles Burner.** This burner, which is of the steam pulverizing type, is used on the shell tankers. The oil, after having been heated by means of a steam jacket, is sprayed out by the steam, and as the burner is constructed to allow of separate adjustment of the steam and oil jets, the consumption of the fuel can be readily controlled to suit the special work it has to do. (Fig. 6, p. 29.)

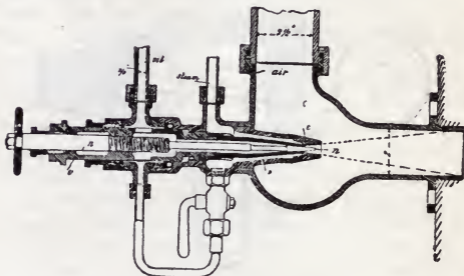

FIG. 5  
THE ORDE BURNER

**The Thompson Atomizer.** This burner is made in different styles to suit any requirement, but two forms of it are illustrated here. The atomizer consists of four parts, namely: the body piece, the nozzle, the spraying or atomizing cylinder, and the spring for keeping the same in place. The hot oil is passed from the burner box or chest into the body of the burner and it then passes down into and through the atomizing or spraying cylinder, where it has a swirling or rotary motion imparted to it before leaving the burner, from which it issues in the form of a hollow cone of vaporized liquid fuel, which can be ignited by means of the common torch inserted through the fire hole. A special

feature in this patent is the providing of a super-heating passage in the walls of the nozzle, to superheat the oil just before it leaves the outlet. This arrangement was devised to deal specially with heavy Mexican oils, which have to be heated to a very high temperature.

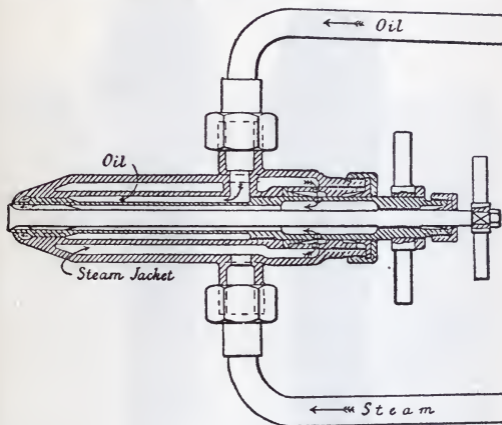

FIG. 6  
THE RUSDEN-EELES BURNER

By having this heating chamber the oil can be used at a lower temperature in the steam heaters. The heaviest Mexican oil can be used with this burner, and an entire absence of smoke is obtained.

The "Thompson" Atomizer is supplied and installed by Messrs. Smith's Dock Company, Ltd., of N. Shields, who also manufacture the "Smith-Meyer" system of oil-firing, in which the fire-bars and other coal-gear are removed entirely and circular patent furnace fronts

substituted. The "Smith-Zulver" convertible system, also installed by this company, has been designed and developed particularly with a view to converting the boilers of steamers rapidly. The firm also supply two

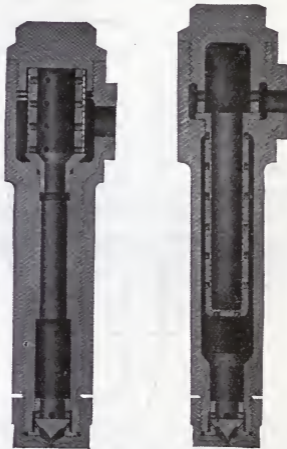

FIG. 7.

THE THOMPSON ATOMIZER (FILTER TYPE)

types of oil fuel heaters—the straight tube heater and the coil type heater.

**The Thornycroft Sprayer.** In the Thornycroft Oil Fuel System the oil is sprayed, under pressure, into the furnace by means of the Thornycroft Patent Sprayer. This has both edges of its supply grooves tangential to the whirling chamber, the spray being produced within a steel cone of special construction,

- 3 Tangential Grooves open and Whirling Chamber maximum size.
- 2 Two Tangential Grooves open and Whirling Chamber further increased.
- 1 One Tangential Groove open and Whirling Chamber slightly increased.
- 0 Tangential Grooves and Exit Hole closed.

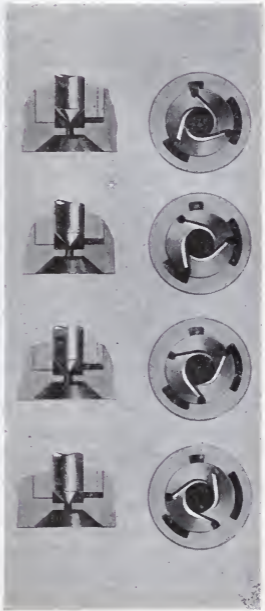
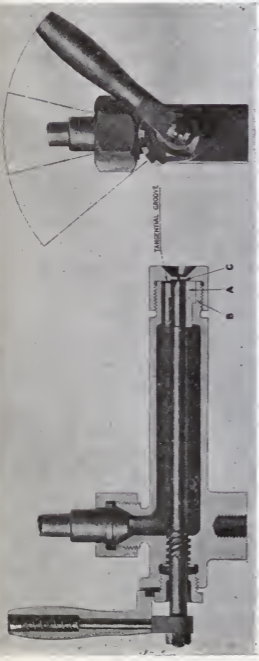

3            2            1            0

Fig. 8

IMPROVED OIL-FUEL SPRAYER (MESSRS. I. THORNYCROFT AND CO., LTD.)

which introduces and mixes the air and the oil spray in such a manner as to produce perfect combustion.

The oil may be of any crude description, such as Texas, Borneo, Mazout or Shale, and is pumped to the sprayer after heating and straining. This system is equally suitable for closed or open furnaces, or for Howden's Forced Draught. (Fig. 8.)

**The Wallsend Burner.** In this burner the oil is supplied from a steam heater and forced into the burner at a steady pressure of from 60 to 80 lbs. per sq. in. The nozzle consists of a nipple, having a conical-shaped orifice of small diameter, from which the spray of heated oil issues in the form of a conoidal column of large diameter, and is capable of burning, in one burner, oil at the rate of from 400 to 500 lbs. per hour. The spray column is caused to acquire a rotary movement by means of a helix on the valve-stem, the resulting centrifugal effect materially assisting in the widely conoidal diffusion obtained. (Fig. 9.)

**The "White" Patent Low Pressure Burner.** The "White" Patent Burner, which is of simple construction is designed to atomize, to the finest extent, the oil previously heated to the point of fluidity by passing the oil through the perforated walls of the burner atomizer and strainer, along grooves which direct it on to a centre cone surface, from which it issues through a disc as a finely-divided spray or mist. The burner atomizes at any pressure from 10 pounds upwards. The orifice in the disc through which the oil spray issues is drilled to thousandths of an inch, and ranges from 30 thousandths to 70 thousandths in ordinary practice. All discs are interchangeable, and may be readily removed for cleaning when necessary. The burner itself is removed from the furnace front for cleaning by disconnecting the quick detachable union, when it

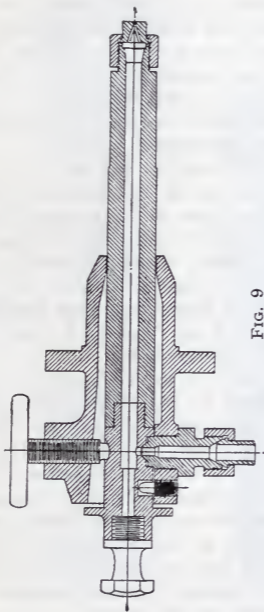

FIG. 9  
THE WALLSEND BURNER

may be withdrawn and a spare clean burner inserted in its place, the entire operation being performed in less than thirty seconds. (Fig. 10.)

The oil atomizer and strainer of fine mesh located in the end of the burner arrests any particles of grit which might otherwise lodge in the orifice of the disc. There is also a safety device, or shut-off cock, attached to the burner head with its handle locking the screw of the quick detachable union, making it impossible to open the union without first shutting off the oil.

Owing to the absence of any steam or compressed air jet to atomize the oil, the operation of the burner is noiseless. The flame is short, under three feet in length, and fills the front end of the furnace. It is a clear incandescent flame, shading to red at the periphery, with a faint trace of violet at the extreme edge.

**The "J. Samuel White" Oil Fuel Burning System.** The construction of the burners is clearly indicated in the sketches given herewith.

Referring to Fig. 1, it will be seen that the oil passes down the centre of the burner body A to the annular passage surrounding the slot plate C. This plate is provided with either one, two, or three slots, arranged to direct the oil in a tangential direction into the whirl chamber at its centre from which it is discharged through the fine orifice in the cap B in the form of a fine mist, in which condition it can be efficiently burnt. The slot plates C and caps B, having slots and orifices of varying sizes, are supplied to suit varying rates of output.

Fig. 2 illustrates the firm's sprayer for burning either hot or cold oil. The construction is similar to that of the hot type burner with the addition of a centre spindle D, and means of adjusting it. In using cold oil, this spindle is protruded through the orifice in the cap B, as shown in large scale view. The oil is fed into the



QUICK DETACHABLE UNION AND YOKE

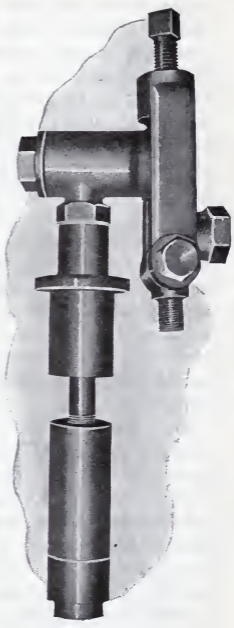
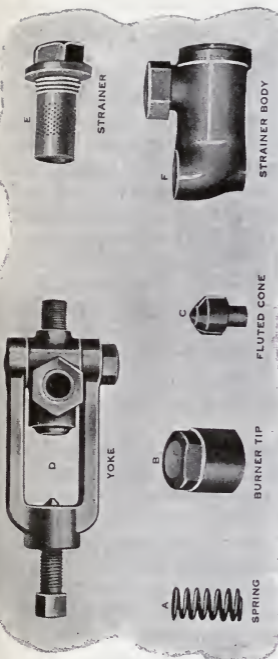
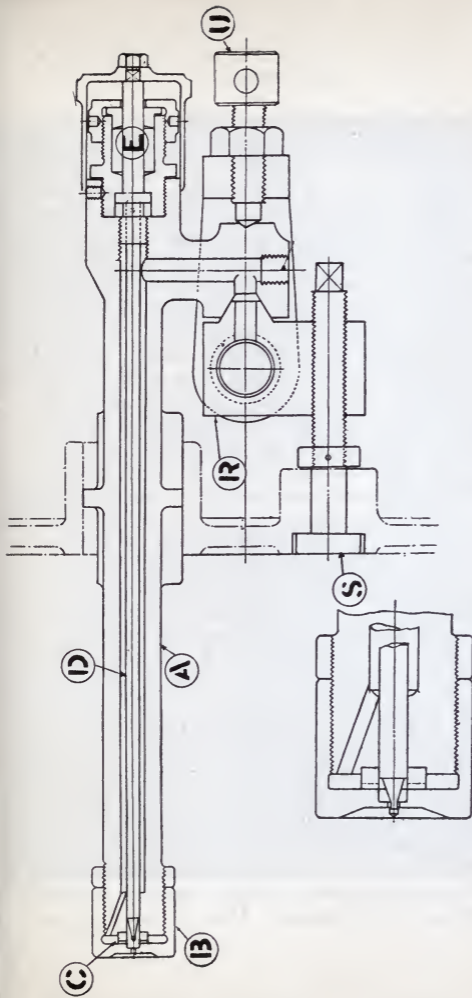

FIG. 10. THE WHITE LOW-PRESSURE BURNER

whirl chamber in a similar manner to that described above, and on discharging from the orifice in the cap B, impinges on the small head formed on the end of the spindle D, and is broken up into a fine mist, in which condition it can be ignited and burnt without smoke. When using hot oil the spindle is withdrawn into position indicated in the sectional elevation by means of the milled cap, when the sprayer operates precisely as the hot type. This burner is particularly useful for lighting-up purposes when steam is not available for use in fuel heaters, being capable of burning fuels up to 900 seconds viscosity (Redwood, No. 1) at normal temperatures, cold, thereby rendering an auxiliary heater unnecessary. In both types of sprayer provision is made for quickly disconnecting, it being only necessary to unscrew U when yoke J swings down, permitting the sprayer to be withdrawn. Provision is also made for axial adjustment of the sprayers by means of the screw spindle S, whereby maximum efficiency can be obtained under all conditions of output.

**The Babcock and Wilcox System.** The method adopted in applying the Babcock & Wilcox mechanical system is that of pumping the oil through the burners at a considerable pressure, the stream of oil being so manipulated in the burner that it is caused to rotate rapidly, and immediately on the emission of this stream from the orifice of the burner the centrifugal force resulting from the construction of the burner breaks it up into a fine mist, which, by proper means of air mixing, can be completely burnt without smoke. This method is adopted in all cases for marine work, where the consumption of fresh water for spraying purposes is not permissible; and the same applies to land installations, where the feed water is of bad quality, in order to avoid introducing an excessive quantity



COLD SPRAYER IN ACTION

"Oil Engineering and Finance"

FIG 11

" J. SAMUEL WHITE " SPRAYER FOR BURNING HOT OR COLD OIL

Loaned by

of make-up feed into the boilers. Moreover, with this pressure system, a high efficiency of combustion is obtainable.

A recent addition to the oil fuel systems is that known as the "Unolco" introduced by the United Oil & Coal Company, and fitted to a number of the Great Central Company's locomotives. In this burner fuel is fed to the main passage, which is preferably set at right angles to the middle line of the burner, into the annular chamber. Superheated steam is supplied to the nozzle by a pipe. This steam heats and liquefies the fuel in the chamber and, upon issuing from the nozzle into the cone, partly atomizes and drives it against the inner walls of the cone, carrying it forward at a high velocity to the ends of the cone. At this point the combined jet of steam and fuel is surrounded by an additional superheated steam supply issuing at a still higher velocity than that of the central jet from the annular orifice. The superheated steam is supplied by the pipe J. The annular superheated steam supply completely atomizes the jet issuing from the nozzle end and is carried forward at an increased velocity to the flattened expanding delivery nozzle.

The burner is placed below the foundation ring at the rear end of the fire-box, the ordinary ash-pan of the engine being retained. Oil passes from the tank, which has a capacity of from 800 to 1,000 gals. for a tender engine, and 450 gals. for a tank engine, through a connecting pipe of flexible material in the case of a tender engine, to the footplate, beneath which is a pre-heater. This pre-heater consists of two pipes, one within the other, the inner pipe conveying oil and the outer one forming a steam jacket, and it serves to reduce the viscosity of the oil so that it will pass through the steam jets of the burner. After passing from the

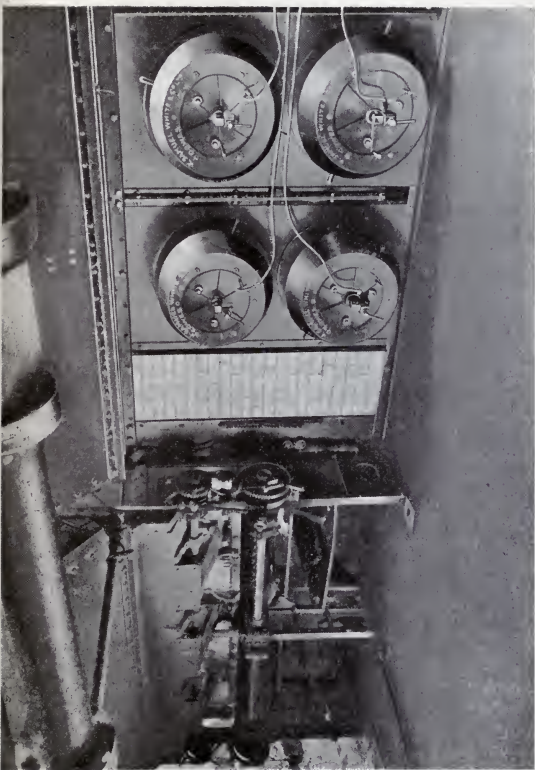

FIG. 12

“ J. SAMUEL WHITE ” LOW-PRESSURE OIL-FUEL BURNING INSTALLATION FITTED  
TO ONE OF BATTERY OF STIRLING WATER-TUBE BOILERS

pre-heater to the burner, the oil is delivered in a spray about 6 in. above the floor of the fire-box, in which there is a layer of fire-bricks, 3 in. thick, resting on a plate at the rear end of the ash-plan.

The system provides for the atomizing and burning of pre-heated oil by means of superheated steam. Each of the three jets in the burner is a double nozzle, the inner nozzle conveying superheated steam which atomizes the oil as it issues in an ignition chamber common to the three jets, and also receiving superheated steam through a vertical port. The three nozzles are so arranged that they can be used separately or all together, thus ensuring the highest efficiency of combustion. In practice, it has been found that one nozzle is sufficient for locomotive work.

The ease with which an oil-burning installation can be manipulated is not one of its least advantages. There is no need of skilled labour in the adjustment of the valves, once the admixture of air and oil has been properly arranged and it is a simple matter to ascertain that this has been secured. It must, however, be stated that the proportion of air let into the furnace is of the greatest importance, as on this depends the approach to perfect combustion. Any excess of air beyond that actually required for complete combustion naturally reduces the temperature and thus retards the process. From a general point of view, that is in the employment of oil fuel for any purpose, on land or sea, the main advantages of oil over coal may be summarized. These features are classified so concisely by Engr. Lieutenant Commander F. T. Addyman in the *Petroleum Year Book*, that I cannot do better than reproduce from that work.

1. Ordinary oil fuel has a higher calorific value, viz., 19,500 B.T.U., as against 12,500 B.T.U. for coal, and

the average engineer would often be glad to obtain 8,000 to 9,000 B.T.U. Heat value of coal is, and always must be, a fluctuating quantity; it varies even on one seam. Not so with oil; it is of known gravity and quality, and therefore can be accepted as a constant; hence, the bed-rock truth is that you are bound to obtain at a minimum 80 per cent greater heat value from oil.

2. An increase in boiler efficiency, due to the clean condition in which the heating surfaces can be maintained, is another advantage; also the completeness of combustion obtainable with a good system of oil-firing (1 lb. of fuel averages 19,500 B.T.U., as compared with 12,500 B.T.U. for best Welsh coal) due to the high calorific value of hydrocarbon constituents and to the high purity of oils, the non-combustible matters, usually, being almost negligible.

3. A constant and equal distribution of heat in the furnaces, and, as there are no fire doors to be opened, the cooling effect of large volumes of air passing over the furnaces when firing up or cleaning fires is avoided, and its consequent losses. Complete control of air supply is maintained.

4. Superior evaporative power for weight of fuel carried, giving increased radius of action.

5. Ease of control and regulation and maintenance of proper combustion.

## CHAPTER IV

### OIL FUEL ON SHIPS

THE branch of industry in which the benefits of oil fuel are most conspicuously observable is that of shipping. In the first place, the space occupied by oil is less than that of coal, one ton of oil occupying only 37 cu. ft. compared with 44 cu. ft. for one ton of coal. Moreover, oil can be stored in a ship where coal cannot be carried, thus the fuel capacity is increased.

It has been proved that by substituting oil for coal an increase in radius of action is attained of 50 per cent on equal bunker weight and 80 per cent on equal bunker space. The effect of this on the per ton mileage of a vessel is, therefore, obvious, and equally so is the economy of space resulting from the substitution. A statement made by a high authority on the subject some time back showed that over a series of years a 7,700 ton vessel consumed about  $22\frac{1}{2}$  tons of oil a day, compared with from 32 to 33 tons of Welsh coal. This implies a saving in weight of fuel consumption of 33 per cent. With coal of inferior grade the economy would naturally be considerably greater. Furthermore, the vessel referred to was enabled to carry from 150 to 200 tons more cargo. Another way of expressing this fact is by comparing the i.h.p. consumption under oil and under coal, the generally accepted figures being, in regard to the former, 1.02 lb. to .95 lb., and for the latter from 1.5 lb. to 1.6 lb. i.h.p. One of the most valuable aspects of oil fuel running from a commercial point of view is the shortening of the duration of the journey. This is an economic factor of far reaching



influence and is not sufficiently considered by shipping companies, though one would imagine it would appeal very weightily to them. Such an advantage, with its many concomitant items of economy, could readily convert a loss into a profit in the earning capacity of a vessel. For instance, in one well-known case a round voyage, which, under coal occupied 186 days, was reduced under oil to 161 days, which, taking into consideration all the economies effected, resulted in an additional revenue of over £4,000.

The next important claim is the increase in thermal efficiency. In the case of oil, working experience has shown that this may be as high as 83 per cent, compared with 60 per cent when coal is employed as fuel. In tests carried out in America recently the thermal efficiency of boilers using coal varied between 66·6 to 68 per cent, whilst in burning oil the thermal efficiency stood at from 80·6 per cent to 81·5 per cent. Efficiencies as high as 84·5 per cent had been secured, under marine type boilers, using Mexican fuel oil with the pressure system of oil burning. In order to arrive at a fair conclusion, the quality of coal used should be taken into account, and should, of course, be stated where comparisons are made, for, while there is always a substantial balance in favour of oil, a low-grade coal will cause the comparison to appear much more favourable than as against a high-grade coal. The following instance may be quoted as illustrating this point: In the conversion of certain boilers from coal to fuel-oil firing, the water evaporation per lb. of coal, with a calorific value of 11,451 B.T.U., was 7·22 lbs. ; whereas, when working with the pressure system of oil burning, using an oil having a calorific value of 18,750, the evaporation per lb. of oil reached 14·44 lbs. The quantity of water evaporated to the square foot of



*Kindly loaned by*

*"Oil Engineering and Finance"*

THE CANADIAN PACIFIC "EMPRESS OF BRITAIN,"  
COAL-FIRED

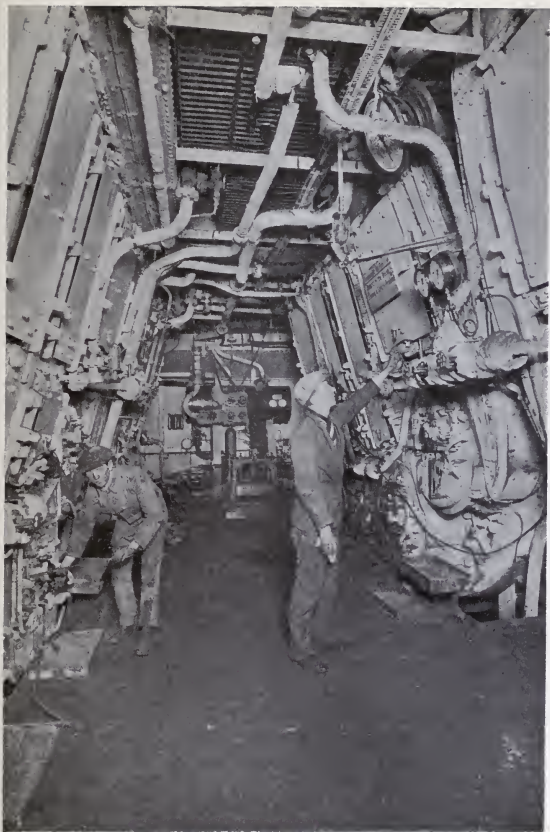

Kindly loaned by

"Oil Engineering and Finance"

THE SAME STROKEHOLD UNDER OIL FIRING

heating surface on coal was 3·3 lbs., whereas oil showed over 7 lbs., thereby increasing the boiler rating by over 100 per cent. With a higher grade coal, this disparity would not, of course, be so marked.

The progress which has been made in oil-fuel practice during the last thirty years is well indicated by figures relative to the evaporation per lb. of petroleum. On a gunboat belonging to the French Navy the water evaporated per lb. of oil is stated to have been from 11·56 to 11·58 lbs. ; on a French torpedo boat in 1890 the quantity of water evaporated was 11·36 lbs., while it was regarded as quite an achievement when this factor attained the figure of 13·25 lbs. Twenty-three years later in the results obtained on a Chilian battleship fitted with a Kermode oil-fuel installation the quantity of water evaporated varied between the average of 12·12 lbs and 15·72 lbs in tests of two hours duration ; while in later tests under marine boilers, with which the Kermode pressure jet system was used, the evaporative efficiency rose as high as 16·16·74 lbs. per lb. of petroleum. Similarly, in regard to the consumption of oil i.h.p. The figures given for this item on an Italian battleship some twenty years ago were 1·25 lbs. of oil compared with 2·13 lbs. of coal, while at the present time, as already stated, the consumption of oil ranges from ·95 to 1·02 lbs. of oil i.h.p., and for coal from 1·5 to 1·6 lbs., showing that in both liquid and solid fuel practice great advances have been made. These figures are an excellent indication of what has been achieved in bringing oil fuel appliances to a high standard and of the progress made by both engineer and chemist in the science of oil fuel burning.

The practice is sometimes adopted of burning oil and coal combined, though this is not generally done. In several evaporative trials carried out on a vessel attached

to the French Navy with the boilers heated by the mixed fuel, and the burning mixture consisting of 45 per cent of petroleum, the water evaporated amounted to 11.34 lbs. a ton of fuel. This showed an evaporative increase of 25 per cent over that of coal. With the proportion of oil increased to 64 per cent, 14.12 lbs. of water were evaporated, showing an increase of 56 per cent over that of coal when used alone.

The records we have already given are sufficient to justify all the claims which have been made in regard to the superiority of oil as a fuel over coal. At the same time they have proved that great advances have been made in the design of appliances. There is, however, still room for improvement, and in many directions efforts are constantly being made to perfect already existing appliances. The United States is the greatest consumer of fuel oil in the world, and a report, issued some little time ago by the Bureau of Mines, states that during the year 1917 about 160 million barrels of oil were used for fuel purposes. The writer of this report asserts that, of this quantity, a conservative estimate shows that no fewer than 40 million barrels might have been saved by a more intelligent operation of appliances and by proper firings. He then proceeded to state that water tube boilers meet the requisite conditions more fully than other types. The points of importance in connection with boiler design which should be kept prominently in view are : The heating surface must be arranged in such a way that the gas passages are long and of small cross section ; the heating surface should " see " as much of the furnace as possible, in order to increase the amount of heat imparted to it ; the combustion space of the furnace must be so constructed that the burning particles of fuel shall be completely consumed before they can touch the comparatively

cold boiler surface ; also, this space should enlarge in the direction of the flow of the heated and expanded gases, as the capacity of the furnace for burning oil is limited almost entirely by the furnace volume ; there should be dampers for controlling the air and the flow of the fuel gases ; uptakes and flue passages should be as free from turns as possible ; the flow of gases counter-current to the circulation of the water in the boiler is desirable, as it permits the gas to leave the boiler at a temperature approaching that of the feed water as a limit ; the possibility of unequal diameter stresses should be avoided in design ; the boiler should permit uniform and positive circulation of the water, and the steam and water spaces should be large enough to maintain uniform pressures and heating conditions.

There are, in addition, other very obvious advantages in the use of oil for power production on ships. Expressed briefly they are : Ease of shipping into bunkers or tanks, and with which furnaces can be supplied, the latter being mechanically controlled to a very fine point, thus enabling steam to be maintained at a constant pressure for an indefinite period. Reduction of stokehold staff. One man can with ease, regulate the pumps and burners for from eight to ten boilers. Less stokehold space required, thus allowing more room for cargo. Absence of coal dust and ashes, which adds considerably to comfort of passengers and crew. Capacity of forcing, when necessary ; the physical endurance of a man is the limit with coal burning. Cost of maintenance and upkeep of department is reduced by at least 100 per cent when the various items are taken into account, e.g. the saving in fire bars, cleaning materials, ash guards, buckets, fire irons, flooring or shovelling plates, and other items too numerous to mention in this article. The absence of small coal and dust lodging in inaccessible



FIG. 13

THE WHITE STAR LINER R.M.S. "MAJESTIC"

The largest ship in the world burning oil fuel is the R.M.S. *Majestic* of 56,000 tons. Her length is over 1,000 ft. and her turbine-propelling machinery develops 100,000 s.h.p. She is capable of carrying sufficient oil for the round trip, Southampton-New York, bunkering the requisite 7,000 tons of fuel oil in six hours. On her first return trip, during a certain period, she attained a speed of 27 knots.

parts of the boiler room. In cases of extreme emergency how often has a rush of water dislodged these items, choking the pumps at a critical moment, with the possible loss of many lives, ship and cargo. This is impossible with oil fuel.

There is almost an absence of smoke arising from properly controlled burners, which, from a navigation point of view, is a distinct advantage—there is no chance of the bridge becoming enveloped in a dense cloud of thick black smoke, with a beam wind, thus obscuring the view of the officer responsible for the navigation of the vessel.

If it is necessary to examine bunkers, effect repairs, etc., the fuel oil can be pumped out in a very short time ; either into the other fuel tanks or into a tank alongside, instead of the very slow and tedious business of discharging coal to various tortuous passages into lighters alongside. The oil can be discharged in a less number of hours than the coal would take in days, and probably by two men ; whereas with coals it would entail the whole staff.

In regard to bunkering, 7,000 tons of fuel oil can be stowed in a ship's tanks in six hours—the same quantity of coal would take forty-six hours, most of the staff being employed, at the rate of, roughly, 150 tons an hour. In short, oil-fired boilers spell greater efficiency, comfort, cleanliness, and economy.

Experience has shown that it entails less labour to attend to twelve or more oil fires than when attending to three coal-burning furnaces. The time necessary for the changing of a burner is less than 60 seconds, while the cleaning of the cones involves nothing more than rubbing over the edge of the cone with a small scraper, and is done at regular periods to ensure a regularity of attention to each furnace. A well-known



authority informed me that in the average oil-fired job, having only one stokehold, one man only is necessary to attend to the burners and fires, and a number of vessels are operating with one man attending fifteen fires. Another well-known expert stated that he had run a five days' hard trial on a naval boiler without cleaning a burner or without dismounting one, and the air cones and furnaces were as free from carbon or blemish of any kind as at the start.

With a proper arrangement, every furnace and every burner should be able to range from the condition of banked fires to full power without altering a burner or making a change of any kind save a regulation of the burner and a regulation of the supply of air. It is obvious to anyone who has been in the stokehold of an oil-fired ship during running, that the work is by no means of an arduous description. It is also a well-known fact that, once a man has served as a fireman in a vessel run by oil, he greatly dislikes returning to work in a coal-fired ship.

With coal-fired boilers there is always a considerable loss of steam every watch, through burning down and cleaning of fires. Take, for instance, the serious loss to a vessel of the *Aquitania* class, which has no fewer than 168 furnaces. Assuming that twenty-eight fires are cleaned every watch, approximately 8,000 h.p. is lost every four hours. With oil-fired boilers no such loss is incurred, as the oil can be supplied continuously to the burners, and the heating maintained so that a constant steam pressure can be kept up. The result of equipping her with oil fuel installations has had the effect of improving the speed of the vessel. The original contract speed under coal was 23.50 knots. In making a recent return journey from America to this country, an *average* speed of 23.45 knots was maintained, while

over a run of 129 miles she attained the maximum speed of 27.40 knots.

The bunkering with oil of this huge ship was effected at the rate of 480 tons an hour, while the *Olympic* can readily take in sufficient oil in six hours to carry her over the round trip. Only three men are required to carry out the entire operation. Before being fitted for oil burning, the time taken to bunker these vessels with coal was about 108 hours at each end, and for this work between fifty and sixty men were employed.

## CHAPTER V

### OIL FUEL FOR RAILWAYS

OIL as a driving power for locomotives, although before the war more generally adopted than for ocean transport, has been far outstripped by the latter since that revolutionary occurrence. The reasons for this are not difficult to discover. In the first place, the facts that practically the whole of the Fleet was converted to oil and shipowners profited by realizing the efficiency of oil fuel burning, and, as one important factor in this, that oil supplies were more ample than they had hitherto believed ; that the advantages gained from its adoption for running locomotives are not so numerous nor so obvious as in the case of traffic which is capable of moving over long distances, and of touching those parts of the world where supplies are available in large quantities ; and that supplies of solid fuel, in unlimited quantities, are either traversed by the railways or are in close proximity to them. The benefits to be derived from the substitution of oil for coal as fuel in the locomotive are, nevertheless, conspicuous. Both time and labour are considerably reduced ; the consumption of fuel is less, not only from the point of view of oil possessing a higher calorific value, but from the ability of the oil-fired engine to take the steepest gradient by merely a temporary increase of oil supply to the burner, which can be returned to the normal when the gradient is passed. With a coal-driven locomotive this special condition of the track involves a considerable and unnecessary wastage of fuel, which there is no means of obviating. In addition to this advantage of a lower

fuel bill and a greater amount of work obtainable from a ton of fuel, there is the saving of time in not having to cut out the engines for cleaning, etc., the greater capacity for steam raising, the saving of fuel when the locomotive is at the terminals, and the saving of time in the loading up with oil over that for coal. On the other hand, nothing is gained in the way of increased accommodation for merchandise, or in the direction of reduction of firemen. The cost of fuel, therefore, has to be borne irrespective of any other advantages, except in regard to those already referred to, and, although these are obvious advantages, they do not affect the earning capacity of a company so strikingly as in the case of a shipping company. They are sufficient, however, to induce many railway companies of this country to turn to oil fuel, at the present time, though the price of oil and reliability of supply at home must always be more deciding factors than in ocean transport. The most vital consideration, however, is that the railway company must always be assured of ample home supply, as it cannot go further afield for this, as can a ship. Even such a national dislocation of the coal industry as occurred in 1921 induced few of the railway companies to resort largely to oil, though a number of main line routes were traversed by locomotives driven by the liquid fuel.

The position is far different, however, in foreign countries, especially in the United States, where oil fuel practice has been increasingly extended on the railways during the last ten years. This is, of course, not surprising when one remembers the extensive petroleum reserves of that country.

The adoption of oil fuel in America, and chiefly in California, was due in the first place to the fire risks which were run in employing either wood or coal.

Many large forest fires were started by sparks from coal-fired engines, and oil fuel was introduced to obviate this danger. With the vast stores of fuel oil, however, at hand, the economic advantages accruing from the change over were soon recognized, and the use of oil fuel on locomotives more than doubled between 1910 and 1920. The figures showing the length of mileage, the total mileage run on oil, and the total consumption are as under—

	Length of mileage under oil fuel.	Total mileage covered by locomotives (1-1,000)	Total consumption in thousand barrels.
1910 . . . . .	22,709	89,107·88	23,817·35
1911 . . . . .	30,039	109,680·97	29,748·8
1912 . . . . .	28,451	121,393·2	33,605·6
1914 . . . . .	29,595	118,737·5	31,093·3
1915 . . . . .	30,776	124,255·5	32,830·2
1916 . . . . .	31,980	140,434·6	38,208·5
1917 . . . . .	33,109	148,825·4	42,238·6
1918 . . . . .	35,211	128,528	36,713·7
1919 . . . . .	—	—	42,961·4
1920 . . . . .	—	—	45,847·0
1921 . . . . .	—	—	38,842·0

The consumption of oil based on these figures appears to amount, approximately, to 10 gallons for 100 ton miles. Before the adoption of oil only, and when the locomotives were run on wood, the cost worked out at £12 15s. 0d. a thousand train miles, whereas the same mileage on liquid fuel was secured on an expenditure of £8 4s. 5d. A comparison between oil and coal on certain American railways showed that 9·92 lbs. of oil were consumed for 100 ton miles, as against 18·20 lbs. of coal for the same distance.

The use of oil fuel has also been varyingly adopted on railways in France, Italy, Russia, Rumania, India, Egypt, Mexico, Japan, and on several lines in different South American Republics. In the majority of those

countries petroleum is produced in large quantities, and the crude oil yields a good percentage of fuel oil. They are thus able to rely on continuous supplies. It may be interesting to state that, during the war, Egypt was saved from a fuel famine by the possession of an indigenous oil supply, which had been developed so successfully during the few previous years.

Another country where railways are practically wholly run on fuel oil is Mexico. As will have been observed from the record of production on page 7, Mexico possesses enormous supplies of fuel oil; the crude yielding a very high percentage of residue oil, suitable for power purposes. The quantities of oil consumed on these railways for each year from 1916 to 1918 were as under (1-1,000 barrels)—

	1916	1917	1918
National Railways .	2,294.3	—	2,637.5
Mexican Railways .	159.6	619.9	580.8
Tehuantepec Railway .	93	129.5	197.7

Interesting tests were carried out on Mexican locomotives, two different types of burners being used. The results of these tests are important as showing the working of the two oil fuel systems, one of which was a pressure system, the other in which steam was used for atomizing the oil.

	Pressure burner.	Steam burner (Wallsend type)
Total weight of freight (tons) .	144	130
"    "    behind engines (tons)	234.6	208.5
Oil used, lbs. . . . .	405	395
"    "    for 1,000 ton miles, lbs.	222	244
Ton miles per lb. of oil . . . .	4.5	4.09
Average strain pressure . . . .	115	112
Drop in strain pressure taking gradient, lbs. . . . .	8	15

The line in question is characterized by many steep gradients, in one instance, at least, the rise being 1 in 25. It is in work of this trying description that oil fuel reveals its superiority, the requisite amount of additional power being secured in the most economical manner. On the National Railways of Mexico the cost of oil fuel a train mile worked out at 5d. as compared with a cost of 7d. a train mile for coal.

The Southern Pacific Railroad, a South American line, converted many of its locomotives to oil a few years ago, and records are available concerning the portion of the track which crosses the Sierras Nevadas. The engine employed was a 10-wheel engine, and the train in this instance consisted of seven cars.

Actual time of running . . . . .	14 hours
Miles run . . . . .	315
Average strain pressure . . . . .	196
Total gallons of water evaporated . . . . .	44,147
Water evaporated, lbs. . . . .	367,642
Oil burned, gallons . . . . .	3,951.6
"    "    lbs. . . . .	31,613
Equivalent evaporation of water per lb. of oil, lbs. . . . .	14.14
Water evaporated a sq. foot of heating surface an hour, lbs. . . . .	8,698
Oil burned for sq. foot of heating surface per hour, lbs. . . . .	.748
Weight of train, tons . . . . .	342
Boiler efficiency, per cent . . . . .	73.84

The oil used during this run was Kern River (California) oil of heavy quality, having a specific gravity of 15.8 Baume (.96) and a flash point of 230° F.

Among the British Railway Co.'s which have initiated the movement towards the employment of oil for running their engines are the London and North Western, the Great Central, the Highland of Scotland, the Lancashire and Yorkshire, and in other parts of the Empire India leads the way, the North Western (State)

Railway having recently converted several of its locomotives to oil burning. These engines were originally fired with coal, and have been adapted to oil fuel by arranging a brick arch in the fire box to distribute the flame. The consumption of fuel oil over a period of six months showed that one ton of oil equals 1.85 tons of coal by weight. The descriptions of fuel used are given by the Government Test House at Alipore as follows—

<i>Coal.</i>		<i>Calorific Value.</i>	
Free Carbon	63.29	Calories a grain	6,965
Volatiles	26.21	B.T.U.'s a lb.	12,537
Ash	1.50	Partly coking	
<i>Oil Fuel.</i>		<i>Calorific Value.</i>	
Sp. gr. at 15.5 C.	.895	Calories per grain	10,826
Flashpoint 80° C.	.187° F.	B.T.U. per lb.	19,596
Viscosity at 37.8° C. (100° F.)	125 secs.	Sulphur	8.86%
		Moisture	trace.

The calorific value of the oil was 58 per cent better than that of coal, while in actual consumption a day it was no less than 85 per cent better.

The locomotive superintendent of this railway stated in his report that brass tubes had not been found satisfactory for oil burning engines, as the nuts and ferrules burnt away quickly, an action which was undoubtedly due to the very high percentage of sulphur in the oil used. In fact, I am unaware of an oil with so high a content of sulphur. He also contended that engines burning oil fuel require more staff and more thorough attention than coal burning engines, as the oil burning arrangements must be kept tuned up. I do not know what description of oil fuel burner was employed on this railway, but the statements made do not conform to practice in this country. If it is intended to convey that an oil burner needs more care than is



given to merely shovelling coals on a fire, then his contention is correct.

This report also states that projections in the fire box, such as nuts or rough edges, the fire hole ring, etc., where friction is likely to occur, soon get burnt away by the intense heat of the oil flame. It is, of course, essential, as the locomotive superintendent remarks, that as equable a distribution of the intense heat generated is secured as possible, which is, of course, a matter the constructional engineer would certainly have in mind, in equipping the engine with oil burning appliances and arranging the interior of the furnace.

The Scarab oil burning system which was used extensively in Egypt during the war has also been fitted to locomotives on the railways in Portugal, Mesopotamia, Sudan, and South America. With this system adopted by the London and North Western Railway for its first main line express locomotive over a distance of 113 miles, and hauling a weight of 294 tons, the consumption of oil was 10.88 lbs. for 100 ton miles, and 32 lbs. or 165 galls. a mile an hour. The Scarab Company claim that with their system 42 lbs. of fuel oil will haul a train a distance which, with coal, would necessitate a consumption of 100 lbs. of coal. The Ceylon Government is also following the growing practice and is converting several of its locomotives to oil burners.

The table on page 60 will be of interest as showing the great fuel economy obtainable in oil over coal for locomotives.

Although these figures are not the most recent, they are sufficiently approximate to illustrate the point desired.

In concluding this section, it may not be inappropriate to reproduce a statement made by Sir James Holden

on the question of fitting a locomotive with oil fuel burners.

The most desirable position of the burners, he remarks, could only be arrived at by long continued experiments, and so far the best results have been obtained with the burner eccentric to the holes in the fire-box. This setting of the burners conduces to economy of steam

	<i>Coal.</i>	<i>Oil.</i>
Mexican Railway—		
Lbs. of fuel the train kilometre . . . .	91.03	61.91
Lbs. of fuel for 100 ton miles—		
Tehuantepec Railway . . . . .	20.8	10.3
Interoceanic of Mexico . . . . .	15.07	6.85
Atchison Topeka and Santa Fe Railway (U.S.) . . . . .	29.83	15.32
A U.S. Railway . . . . .	{ 20.36 27.45 18.16 17.83 }	9.92
Great Eastern Railway . . . . .	15.1	7.82

at the ring blower jets, as it utilizes the steam to its utmost for an induction. The ring blower attached to the burner is arranged eccentrically to the nozzle, and the brick axle, usually provided on coal-burning engines, is retained to obviate the too-direct passage of products of combustion to the tubes, and to ensure thorough combustion. The fire-door, in this design, is provided with a deflector to direct downwards into the centre of the fire any air admitted to the fire door. Thus all the features necessary to the successful burning of solid fuel are retained.

## CHAPTER VI

### THE INTERNAL COMBUSTION ENGINE

INTERNAL combustion engine is a generic term which comprises all descriptions of engines in which air and oil are brought together in specific quantities, and by their mixture are exploded. There are thus internal combustion engines in which light oils are used, as in the motor car and aeroplane engine, and those in which heavy oils are used, as in the Diesel and Hot-bulb types of engine. The principle of combustion is the same in both types of engine. The term has, however, become almost wholly associated with the Diesel type.

It was not until Dr. Diesel designed an engine in which it was possible to bring about the combustion of heavy oils that the application of the internal combustion engine became applicable to industrial and transport work. The original design was for its use in stationary work, and it was not until the engine was taken by the various marine engineers in different countries that its applicability to propelling ships was recognized. The latter direction now appears to offer the widest field for the use of this type of engine.

These engines now fall into two distinct categories, namely, the two stroke and the four stroke, but, before referring in detail to the differences between these, it may be advisable to describe briefly the actual operation which takes place in the Diesel engine of any type. This operation consists of four well-defined actions; first, the suction stroke, by which the piston sucks air and oil through a valve into what is termed the vaporizer;

second, the compression stroke, which merely compresses the mixture ; third, the explosion stroke, during which the gas is exploded or burnt, and fourth, the exhaust stroke, which ejects the burnt gas through the exhaust valve. This, very simply, embraces the whole process by which the Diesel engine works.

Reference may now be made to the two distinct types of this engine, namely, the two cycle and four cycle, in each of which, however, precisely the same operations take place. The difference between the two types is that in the former an explosion occurs with every revolution, while in the latter an explosion occurs on each alternate revolution.

There is, however, another description of the internal combustion engine, known as the hot-bulb or semi-Diesel engine. In this the explosion of the gas is produced artificially, and not, as in the Diesel, as a part of the actual operation, and further reference will be made to this type later. For the moment we will restrict our attention to the variations which have been introduced by the different firms into the original design. It is unnecessary in this little work to describe the characteristics of each Diesel engine now available. I will, therefore, restrict this review to those types which are in greatest use at the moment, and to those which embody some distinct feature, differentiating them from previous types. At the present time, the majority of engines constructed are on the four cycle principle, though in Great Britain the two cycle type is more largely favoured.

The principle exponents of the four cycle type are Messrs. Burmeister & Wain, of Copenhagen, and the largest motor ship now running is equipped with engines constructed by Messrs. Harland & Wolff, who are licensees of this engine in this country. In order to give

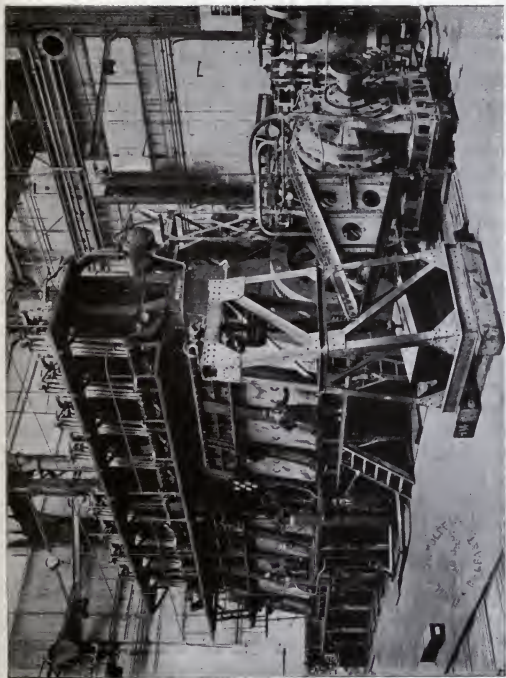

FIG. 14

3,000 B.H.P. (BURMEISTER AND WAIN) MARINE ENGINE, CONSTRUCTED BY  
MESSRS. HARLAND AND WOLFF

a clear and concise description of this engine I cannot do better than reproduce that which appears in the *Petroleum Year Book*. It states that this engine is built according to the four-stroke cycle system, whereby during each second stroke cold air is sucked into the cylinder, which during the stroke cools the internal surfaces. As this suction of cold air takes place in the cylinder itself, it is not necessary to use scavenging pumps, which form a necessary part of the Diesel engines working according to the two-stroke cycle system. The result is that the four-cycle engines are not so complicated, and, as they are not fitted with scavenging pumps, the cylinder dimensions can be increased to such an extent that within the same length, height and engine weight, the b.h.p. will be, at least, the same, or in most cases larger, than for a corresponding engine of the two cycle system. The ordinary opinion that a two-cycle engine gives double as much horse power as a corresponding four-cycle engine is therefore not quite correct.

On account of the cylinders of the four-cycle engine being filled by pure air, the combustion is very fine, and the consumption of fuel oil in b.h.p. is 15 to 20 per cent smaller than for a corresponding two-cycle engine, and as that quantity of oil which is burned without being transposed into useful work will be lost as heat in the exhaust gas, and will heat up the different parts of the engine, the four-cycle engine will work at a lower temperature, which will increase the durability of the engine, reduce the costs of upkeep, and allow uninterrupted non-stop runs for very long periods; and many voyages have been made with Burmeister & Wain motor ships of a duration of fifty to sixty days without any stoppage.

The engine is built as an enclosed, forced lubricated

engine. This design has been adopted from the very first of the motor ships, the M.S. *Selandia*, and the result of this was an absolute working reliability of the engines, with no wear and tear of the rotating parts, and therefore attendance to the machinery is independent of the number of cylinders and appurtenances.

The Burmeister & Wain Diesel engine installations are constructed in such a way that not only the main propulsion power is delivered by Diesel engines, but also all the auxiliary machinery which is necessary in a modern, first-class ship is driven by Diesel engines, the power being transferred through electricity. All the necessary auxiliary pumps, such as cooling water pump, forced lubricating oil pump, bilge and sanitary pumps, auxiliary compressor, etc., are coupled to electromotors, driven from auxiliary Diesel dynamos, which also give the necessary power for working the deck machinery, as electric steering gear, electric windlass, cargo winches, lighting and wireless telegraphy. This arrangement has effected considerable saving compared with the old manner of steam working auxiliaries, both during daily working at sea and during loading and unloading at port.

The best example I can select of the two-cycle type is that constructed by Messrs. Sulzer Bros.

The Sulzer engine is of the two-cycle type, with four or six cylinders working on one propeller shaft.

The cylinder head is of simple symmetrical construction, containing only a fuel valve and a starting valve in a common casing. Ample cooling spaces, ensuring efficient water circulation, are provided. The exhaust pipes are also efficiently cooled, as well as the partitions in the cylinder liner between the exhaust ports.

The pistons are cooled with sea water or with oil. The cooling medium is conveyed to and from the piston

by means of a patent device, which, while avoiding the use of all stuffing boxes or swivel points, nevertheless keeps perfectly watertight. The whole cooling system works under atmospheric pressure.

All the principal parts are fitted with forced lubrication, which experience has shown affords the best guarantee for reliability, and reduces wear to a minimum. The lubricating oil is cooled and filtered in its circulation in an easily accessible double filter.

Starting is effected by means of compressed air supplied from an amply dimensioned air injection compressor, and stored in a number of starting vessels for repeated manoeuvres. The air injection and starting vessels can be controlled from the engine platform. A fuel pump is fitted for each working cylinder, the individual parts being contained in a common casing. The air injection compressor is of the three stage type, with efficient cooling, separators, and safety valves between the stages. The valves of this air compressor are of the plate type of special construction, and can be easily and quickly adjusted, cleaned, or changed.

In the Sulzer Patent system of scavenging, in which two rows of ports are provided in the cylinder liner, the direction of the air currents causes a more thorough scavenging of all parts of the cylinder, and the exhaust gases are effectively expelled. With the system of scavenging through valves in the cylinder head, the scavenge air tends to take the shortest way to the exhaust ports, without properly displacing the products of combustion in the upper part of the cylinder.

This system of scavenging obviates the possibility of pre-ignition in the cylinder and explosions in the receiver on account of the valve which controls the admission of air to the ports being protected from the hot gases by the piston, and not coming in contact with



them whilst at their highest temperature. The scavenge valve works always in the coolest part of the cylinder, and any entrance of unburnt fuel vapour into the scavenge air receiver is practically impossible.

Three other types which possess points of special interest are the Camellaird-Fullagar, the Doxford, and the Vickers. It is essential that the student of this branch of engineering should be acquainted with these and I therefore deem it advisable to introduce brief descriptions of them. The two former are of the opposed piston type, and the latter is known as the solid-injection type.

Camellaird-Fullagar Diesel engines are of the two-cylinder opposed piston type and of a very novel design which, whilst permitting the use of opposed pistons, calls for the addition of few extra reciprocating parts.

The unit consists of pairs of vertical side-by-side cylinders carrying a straight liner, and affording straight-through scavenging by means of ports in the walls.

Two pistons are provided for each cylinder, the lower one in each case being coupled with a connecting rod to a two-throw crank-shaft. Each of the upper pistons is connected by means of a diagonal rod to the lower piston in the adjoining cylinder. When combustion takes place between the two pistons the upper one misses and thus exerts an upward pull on the adjoining lower piston, whilst at the same time the lower piston in the cylinder in which combustion occurs is forced down, bringing with it the upper adjoining piston.

Instead of the fly-wheel being called upon to overcome compression in a cylinder, the direct combustion force is used, and thus, instead of the crank-shaft's having a downward load on one throw and an upward one on the

other, it is constantly subjected to a positive rotating force. Each cylinder, therefore, directly utilizes a part of its potential driving power to overcome the period of inactivity in its neighbour. The driving couple present in all other types of internal combustion engine is thus eliminated, and a rocking force on the crank-shaft is eliminated in favour of a constant load.

The disadvantages naturally associated with diagonal rods are overcome by the provision of suitable guides to overcome the heavy side thrust which is inseparable from the design. It must be remembered that from the nature of the lay-out the diagonal members are always in tension, and, therefore, a complexity of forces is not in evidence.

Fuel valves are, of course, in the centre of the cylinder and between the pistons. They are cam operated from a horizontal skew-driven cam-shaft.

Reverse is direct and is easily effected by altering the valve timing by means of a slight rotation of the cam-shaft. Air starting being employed, the reverse is very readily brought into action.

The novelty of the design of Camellaird-Fullagar engines is justified by many advantages. The hull space which is occupied by one of these engines and a more conventional type is h.p. for h.p. considerably less; the engine can be run at a very low speed, greatly facilitating manoeuvring in harbour, etc., the weight of the unit is extremely low, and both first cost and running expense are, owing to the absence of complexity, extremely low.

Doxford oil engines for marine and stationary work are a combination of the Diesel and the Hot Bulb type, embodying the advantages of the former in regard to mean pressure and consumption, and, in regard to the latter, for simplicity. They are of the two-cycle type,

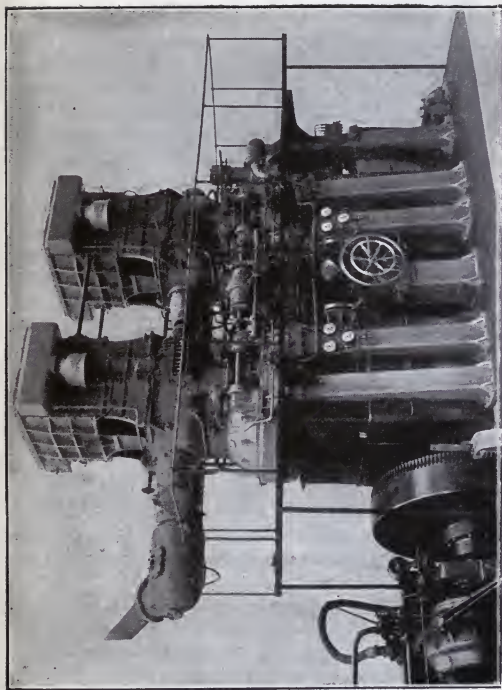

FIG. 15  
THE CAMELLAIRD-FULLAGAR ENGINE

working on a low compression pressure, and burn Mexican fuel oils.

The cylinders consist of a plain tube close-grained casting one inch thick for the largest diameter, with scavenging ports at the lower end, and exhaust ports at the upper end controlled by the respective pistons, permitting the most efficient scavenging.

The piston heads exposed to the flame of combustion are of ingot steel forgings, retaining a high temperature to assist combustion of the heavy fuel oils. They are easily removable without breaking high pressure joints.

No stresses are passing through the frame structure and main bearings excepting those on the crosshead guides, the loads on the pistons being transmitted direct to the crank-shaft through steel rods.

Fuel valves are of special design, conspicuous for the absence of glands and springs, and are so arranged that the oil sprays do not come in contact with the pistons or cylinder walls.

Fuel pumps, one to each cylinder driven direct off the crank-shaft, and have no glands.

Reversing is effected by ahead and astern cams, the cam-shaft being moved longitudinally by hand and lever. Compressed air is used to start rotation of the engine, then changing over to oil, which is ignited at the lowest revolution.

Marine engines are of exceptionally long stroke, and therefore suitable for single screw drive of the highest power. The normal speed for 3,000 horse-power is 77 revolutions, manoeuvring down to 16 revolutions. No air compressor is used for injection, as they operate on "Solid Injection."

The Vickers Diesel engine is of the four-stroke cycle, this type having been adopted as being the most

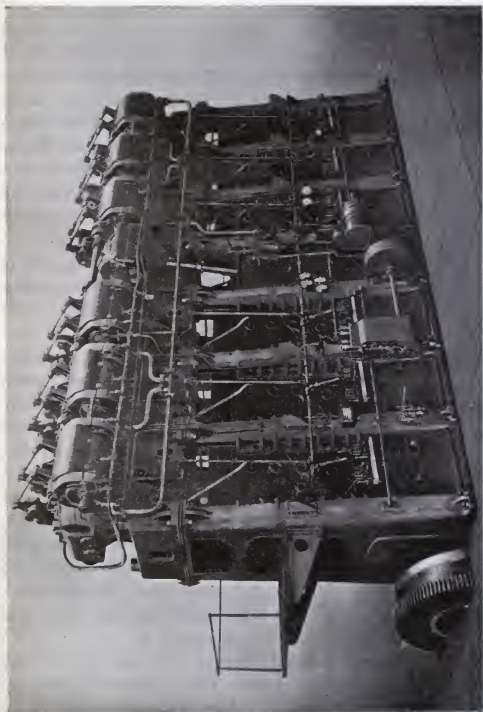

Fig. 16

1,250 B.H.P. VICKERS MERCANTILE HEAVY OIL ENGINE AS FITTED TO  
MOTOR TANKER "SEMINOLE"

economical and practical for the purpose of propelling merchant ships.

The columns are of cast iron, and span the main bearings. Vickers have made oil engines varying in design from the enclosed type, where the cylinders are supported on cast crank cases, to the open class supported on cast columns, turned pillars, or built-up boiler-plate transverse frames. Of these the transverse frame has been found to give such accessibility to the engine that this type has been adopted for the commercial design, castings being used in this case in order to secure the exceptional rigidity so necessary for durability.

The guide is a single one, spanning the columns on the ahead side (generally inboard), the slipper and cross-head details being in accordance with the best steam engine practice.

The cylinders consist of massive conical iron castings, spread at the lower extremity to form a continuous entablature to which the columns and stays are attached. The liner is dropped into the cylinder and held in place by the cylinder cover, being free to expand at the lower end.

The cover is an iron casting of the usual pattern, providing special allowance for difference of expansion. A novel arrangement is followed for thoroughly cooling the lower face and the top of the liner, and preventing deposits on parts subject to the higher temperature. Cleaning doors of ample dimensions are fitted to the water spaces.

Both inlet and exhaust valves are of special steel, the latter being water-cooled. The motion is developed from the designs followed by Vickers in their high duty reversing engines, and comprises very few parts.

The power reversing is applied as directly as possible, thus saving air and making the engine manageable at

low air pressures. Hand gear is fitted for use in emergencies.

Forced lubrication is fitted throughout the principal bearings of the engine. The crank-case is totally enclosed, except for ventilation pipes, by readily portable casings, thus ensuring a clean engine room and preventing contamination of the lubricating oil by dirty oil from the pistons or by water from the glands of the piston cooling pipes.

The fuel injection pumps are in front of the engines, in view of the engineer, and deliver into a main from which the individual cylinders are supplied through their spray or measuring valves. These valves can be controlled collectively by a hand lever, while in case of necessity an individual cylinder can be immediately cut out of action.

The air starting compressors will, in the larger installations, be separately driven, though in the smaller ships it may be preferred to drive pumps by means of a clutch from the engine shaft, thus following the lines of many shore installations of gas or large semi-Diesel engines.

A point of departure from other Diesels is in the adoption of a fuel injection system in which the air compressor is entirely eliminated. With this system consumptions by the hour down to 0.378 lbs. b.h.p. have been obtained.

In addition to these another variation has been invented, namely, that known as the Still engine, the chief feature of which is that it embodies the Diesel and the steam cycles, each reacting upon the other. This is effected by utilizing a considerable portion of the heat in the cooling water and exhaust gases, whereby the efficiency is increased by 20 per cent. The cylinder jacket forms part of a high-pressure steam circuit, a temperature of about 350° F. being maintained by the

heat from the exhaust gases. In addition to maintaining the temperature from these sources of heat, steam is also produced and utilized on the under side of the piston in a similar manner to that adopted in a reciprocating engine. The upper end of the cylinder is operated as a two-stroke Diesel engine. Connected with the steam circuit is a boiler in which steam is generated for starting the engine, and the circuit is effected by steam on the under side of the piston.

Owing to the high temperature of the cylinder walls, the outsides of which are jacketed with water at a temperature of  $350^{\circ}$ , a compression pressure of about 280 lbs. the square inch is sufficient to cause ignition, instead of the usual compression pressure in Diesel engines of 450 lbs. the square inch. Moreover, greater horse-power can be obtained from a given size of cylinder and, if an increase of horse-power is demanded, it can be met by maintaining the boiler, fired with liquid fuel, in commission. The low consumption of 53 lbs. per b.h.p. per hour has been obtained with one of these engines.

Before passing on to other aspects of this subject it may be helpful to introduce a table giving particulars and measurements of the chief types of Diesel engines.

Make.	B.H.P. the Eng.	No. of Cyls.	B.H.P. the Cyl.	B. Bore in.	S. Stroke in.	S.B. ratio	R.P.M.	Piston Speed ft. a min.	M.E.P. lb. in b.h.p.
Burmeister & Wain	3,000	8	375	31.49	47.24	1.5	100	788	80
Werkspoor	1,560	6	260	26.378	47.24	1.79	110	868	72.5
Sulzer	4,000	6	666	32 <sup>1</sup>	48 <sup>1</sup>	1.5	100	800 <sup>1</sup>	68.5 <sup>1</sup>
Ansaldo	1,100	4	275	24.8	35.4	1.43	100	590	64
Doxford	2,200	4	550	22.947	45.67	1.99	77	585	74.5
Fullagar	1,000	4	250	18 $\frac{1}{2}$	25	1.35	110	458	67
M.A.N.	900	3	300	18	28	1.55	120	560	75
Still	400	1	400	22	36	1.63	120	720	Oil 63.2 Steam 33.3 } Total 96.5

<sup>1</sup> Approximate figures.



I have already stated that the two-cycle engine finds greater favour in this country and engineers have devoted considerable attention to its construction. The improvements which have been made in this type may be shown in the statement that when the two-cycle was first constructed the engine had a fuel consumption of about .54 lbs. in b.h.p. the hour, whereas it now stands at .41 lb. in b.h.p. the hour. The pressure of scavenging air has also been reduced from 5-6 lbs. the square inch to about  $1\frac{1}{2}$  lbs. the square inch, resulting, of course, in a correspondingly smaller scavenging pump, without sacrificing, but rather increasing, the maximum efficiency.

The fact that the two-cycle engine requires only four cylinders, while the four-cycle requires at least six for manoeuvring purposes, thus adding considerably to its cost and weight, and necessitating 50 per cent more working parts, has no doubt largely influenced British engineers in their preference for this type. Its greater mechanical efficiency, in spite of other disadvantages, has also no doubt been an attractive feature, while at the same time greater cargo space is permitted. The four-cycle type is, however, rigidly adhered to in Continental practice, and is mostly in favour among American engineers. It is probable that this preference is due to the fact that the engine is stressed to its maximum for only  $12\frac{1}{2}$  per cent of its running time, compared with 25 per cent in the case of the two-cycle engine, and that long experience has confirmed its reliability. Another favourable feature of this type is that its parts are readily accessible, and lend themselves to easy repair. If, for instance, any trouble arises with the exhaust or fuel valves, the engine can be stopped, and the defective valves replaced in about half-an-hour. Experience has shown that during a voyage of six months it is

necessary in this type of engine to overhaul and regrind the exhaust valves twice. The fuel valves should, to keep them in condition, be overhauled twice, while the starting air valves can endure a year's service without attention, though it is preferable to overhaul these once in every six months. The inlet valves can carry on for a year, at the end of which period Lloyd's demand a survey. In regard to compressors—on the main engine compressors it has been found in practice unnecessary to touch the valves between cleaning and regrinding, that is about once in six months.

.The four-cycle engine is more economical in fuel consumption, and in tests which have been carried out it has been proved that the two-cycle engine consumes, approximately, 100 per cent more oil the square inch of cylinder than the former type. On the other hand, the mechanical efficiency of the four-cycle engine ranges between .75 and .85, while the two-cycle type varies between .68 and .78. Moreover, the weight of the former type is less than that of the latter, as, for instance, 1200 b.h.p. four-cycle engine weighs 200 tons, compared with 220 tons for a two-cycle engine of the same size. Another point against which objections are raised to the four-cycle type is that scavenging involves two lost strokes out of the four, and the piston and running gear, which is designed for maximum working-pressure, must be operated through one complete revolution for the purpose of scavenging the cylinder. This, of course, means a loss of power. In the two-cycle engine the charging and scavenging are carried out through pumps and gear provided for the purpose, though this does not increase its comparative efficiency either mechanically or from the point of view of fuel consumption. An improvement in scavenging arrangements has been

introduced into the opposed-piston type of engine. These are of a simple character, the air ports surrounding the cylinder at one end and the exhaust at the other, enabling the scavenging air to sweep through the whole of the cylinder. This form of scavenging induces low fuel consumption, ability for slow running, and a high output by unit of cylinder volume.

The employment of air compressors for the injection of the oil is also a matter on which considerable difference of opinion exists, some authorities contending that greater efficiency is secured thereby as contrasted with mechanical injection. It has been asserted that the compressors employed with marine Diesel engines are larger than is necessary for the work they are called upon to do, with the engine even at full speed. It is essential, of course, that the compressor shall be of such power as to be equal to this stage of working, and there must be a certain amount of waste energy when the engine is running at less speed. The compressor must naturally be capable of meeting all demands. The air injection system is claimed to provide a better fuel consumption than any other method. It undoubtedly possesses an elasticity which no other system has so far provided and enables practically any grade of oil to be used apart from its other improvements. The Camellaird-Fullagar engine is able to start from cold oil, with a specific gravity of  $\cdot 96$ , and containing even 4 per cent of ash. The mechanical injection system has certain advantages to recommend it, though it is not generally adopted, and the energy available for pulverizing the oil is not as great as in the case of the air compressor. It is clear from the statements made that the design of the marine Diesel engine has not yet reached perfection and that there exists a difference of opinion among engineers on many important points; the progress made

in its improvement has, however, been greater than has been the case of the steam engine

This is shown in a table compiled by Sir Dugald Clerk some short time ago, which is as given below. The figures bring this aspect of the subject down to 1914, and practically represent the position at the present time.

	Steam engines. Thermal efficiency to heat of steam supplied to engines.		Internal combustion engines. Thermal efficiency to heat of gas supplied to engines.	
	Indicated.	M.E. 90%	Indicated.	M.E. 90%.
1882	12·7%	11·4%	16·0%	14·0%
1914	23·0%	19·5%	37·0%	33·4%

Expressing the improvement indicated in percentage figures the table shows that with the steam engine the progress made represented by increased indicated horse-power was 81·10 per cent, and in brake horse-power 71·05 per cent for the internal combustion engine, the percentage progress during the period was in indicated horse-power obtainable 131·25 per cent and in brake horse-power 121·25 per cent.

It is evident from a study of the whole question that an important aspect of the Diesel engine construction in order that it may attain a greater amount of reliability is that concerned with metallurgy and methods of manufacturing the different parts. Great importance, for instance, attaches to the manufacture of the castings, and it is a point which is being realized in this country. In some instances firms are setting up their own plant for the production of these, on which the reliability and efficiency of the engine so much depends. This will enable them to test every casting thoroughly before use. Among Continental manufacturers the greatest care is taken in the production of castings and in the selection of the metal, and for such vital parts as liners, cylinder

covers, valves, and pressure parts, the cast iron is melted in the electric furnace or reverberatory furnace, a slightly more costly method, but ensuring a high grade product. With an engine on which such great strains are placed it is essential that the raw material and the ultimate product should pass the most rigid tests.

Another variation of recent invention is that known as the Sproule engine, the object of which is to provide an internal combustion engine having a steam engine "characteristic," that is to give high efficiency at light as well as full load, and to give an overload capacity with slightly falling efficiency and to be easily reversible.

The latest types of engines show distinct progress in design, and, where constructional and metallurgical difficulties have arisen, they are being removed by constant study and experiment on the part of those engineering firms who have placed and kept British craftsmanship in the forefront. The main lines along which development should be made are those leading to simplification of design and economy of production. Up to certain powers reliability and efficiency have been attained, and such excellent progress has been made in the designing and construction of larger units, that powers of 6,000 and over are anticipated by recognized authorities in the near future. The economic aspect of the application of the Diesel engine to marine work is an important part of the subject, and I have thought it preferable to retain this for treatment in a separate chapter.

Reference must also be made to what has been termed the Semi-Diesel engine, but more correctly known as the Hot-bulb type. The differences between these two classes of engine may be briefly stated. In the first place, in the true Diesel engine the heat required for combustion is induced within the engine by compression

and as a part of the operation, whereas in the hot-bulb type the heat is produced artificially. The compression in the former may be stated at 450 lbs. compared with between 150 to 200 lbs. for the latter. Fuel injection and pulverization in the Diesel engine is produced by an air blast of from 800 to 1,000 lbs. the square inch, but in the other type this fuel injection is effected by a small plunge pump to each cylinder driving the oil into a heated chamber or hot-bulb; the oil is ignited by the compression stroke. For starting up the engine a blow-lamp is used to heat the bulb, which, once the engine is running, remains heated by the explosion of the gas. In a few instances compressed air is employed for the injection of the fuel, but the method is not at all generally adopted.

The hot-bulb engine, being of the heavy, slow-running type is chiefly used by small commercial ships, such as coasting vessels, fishing boats, barges, and similar craft. The fuel best adapted to this engine are gas oils, solar oil, which is of higher specific gravity than fuel oil, and heavy paraffins. The sizes of this type of engine vary between 3 b.h.p. and 500 b.h.p. There are a considerable number of firms constructing these engines, for which there is an increasing demand, and, although the fundamental principles of design are the same in each engine, over forty varieties exist embodying some improvement in detail.

## CHAPTER VII

### THE MOTOR SHIP

THE adaptation of the Diesel engine to marine purposes has made remarkable progress since the first motor ship was put into service. The economic advantages of this type of ship compared with the steam-driven vessel are numerous, and are more conspicuous than in a ship driven by direct oil-fired boilers, which, in its turn, is a considerable advance over the coal-fired ship.

It is true that the internal combustion engine for marine use is still in its early infancy, and the various engineering and chemical problems involved in its design have not yet been thoroughly mastered. At the same time, the advanced state of general knowledge in these two branches of science is an advantage which the early years of the steam engine did not possess, so that it may be expected that the weaknesses of the later type of power production will be quickly eliminated and the engine brought to such a state of perfection that it will be safely adaptable to vessels of much larger tonnage than it is at present associated with. There are many, indeed, who assert that the internal combustion engine will rapidly displace the older form of fuel firing, which is a point worth a moment's consideration.

The conversion of a coal-fired vessel to an oil-fired vessel is simple, and requires but a short time to effect ; moreover, the steam engines, which are of a very costly character, are retained. In the case of an existing vessel, to substitute internal combustion engines for the whole of the steam engine equipment would entail

an enormous capital expenditure, apart from the fact of the much higher cost of the former. The cost of a direct installation is considerably higher than that of a steam plant of similar horse-power. Generally speaking, the former may be roughly taken at between 25 and 33 per cent higher than the latter, but it must be remembered that there are many counter-balancing advantages in the use of a Diesel driven ship over a coal-fired steamer. There is, for instance, a larger amount of space conserved for cargo, etc., by the elimination of the boilers, and, therefore, the earning capacity of the vessel would be proportionately increased.

The cost of fuel is also another important item in favour of the motor-driven ship. It is clear that the saving in oil as compared with its consumption when burnt under boilers is great ; in fact, it has been proved in practice that a motor ship can be operated on about half as much oil as that required for running an oil-fired steamer, and that a ton of oil in a Diesel engine will do the work of between 4 and 5 tons of coal. It stands to reason and chemical knowledge that when oil is consumed under a furnace in the manner it is at present the thermal efficiency obtainable from it cannot be secured in so high a proportion as when employed in an internal combustion engine.

Comparing oil with coal, it has been estimated that a ton of oil, when used in a Diesel driven ship, will do as much work as from 4 to 5 tons of coal. The advantages of such a means of propulsion are obvious, while at the same time there is the further benefit of not being dependent on coal. Expressing this fact in a simple manner, the consumption of oil an hour i.h.p. on a Diesel vessel amounts to 1.02 lbs., compared with 1.5 to 1.6 lbs. of coal. This means a saving of fuel of approximately half a pound of fuel i.h.p. an hour,



which, if calculated out for a long voyage, will show an enormous saving in the fuel bill alone, while at the same time a very great reduction of time occupied in transit is effected on account of the higher speed at which the vessel will travel and the elimination of the lengthy business of coaling.

In the early days of motor ships 8 and 9 knots was the speed attained, but this was very soon increased by improvements in the design of engine, resulting in obtaining higher thermal efficiency.

The motor ship *Vulcanus*, one of the first vessels equipped with internal combustion engines, consumed 134 tons of petroleum in 65·7 steaming days, or an average of 2·03 tons a day. This boat was of 1,235 tons deadweight capacity, and was fitted with six-cylinder four-cycle Werkspoor-Diesel engines, and had a speed of 8 knots. Its cargo-carrying capacity was between 12 and 15 per cent greater than that of a steamer of equal dimensions. In the *Juno*, a vessel with a displacement of 2,345 gross tons, and a mean speed of 9 knots, the total consumption of fuel, for all purposes, worked out at 86·21 tons of 4·75 tons a day for a certain mileage. The *Selandia*, a motor ship of 4,950 gross tons, over a mileage of 268, consumed an average of 8·6 tons of petroleum a day.

The total number of crew employed on the *Vulcanus* was sixteen, and the cost of running a day amounted to £6 6s. 5d., compared with a staff and crew of thirty for the coal-burning vessel, and a cost of £9 0s. 7d. a day.

At the present time, a vessel of 10,000 tons deadweight capacity, and fitted with Diesel engines equalling 6,600 horse-power, makes a speed of 14 knots—a remarkable achievement, considering the comparatively short period this type of internal combustion engine has been adopted

for marine purposes. Concurrently with this, of course, a considerable economy has been effected in fuel consumption, which naturally varies, according to the B.T.U. obtainable from the oil used, and the size of the engine employed. A 13-knot ship attained an average speed, loaded, over a long voyage, of 11·7 knots, on a fuel consumption of 12·2 tons of fuel oil. The maximum cargo carried, including 1,300 tons of oil, amounted to 9,400 tons; her cruising radius was 120 days at a speed of 13 knots. The fuel consumption in i.h.p. worked out at 133 grammes.

The following table sets out concisely the speed and fuel consumption of early and recent motor ships—

	Tonnage.	Knots.	Daily fuel Consumption. Tons.	Coal consumption in ratio of 4 to 1 of Oil. Tons.
Selandia . . .	9,800	8	8·6	34·4
Juno . . . .	4,200	9	4·75	19
Bullaren . . .	9,500	13	12·1	48·4
California . .	8,200	9-11	9·14	36·6
Cethania . . .	3,200	9-5	6·3	24
Santa Margherita .	9,916	—	10·19	40·8
San Paulo . . .	6,500	11·5	8½-9	34-36
	d.w.c.			
Buenos Aires . .	5,614	11·5	10¼	41
	gross			
Narragansett . .	6,980	—	9½	38
	gross			
Stureholm : . .	7,800	—	10¼	41
	d.w.c.			
Dorsetshire . . .	7,500	12	11-12	44-48
	gross			
Ansaldo San Giorgia II. . . .	8,100	11	9·85	39·4
Glenady . . . .	7,520	11½	10½	42
	d.w.c.			
Siam . . . . .	8,720	11	10·2	40·8
	d.w.c.			

It was considered in the early days of the Diesel-engined ship that the engines would not be able to drive



FIG. 17

THE M.S. "YNGAREN," FITTED WITH DOXFORD OPPOSED PISTON HEAVY OIL ENGINES.

COMPARISON OF RUNNING COSTS OF DIESEL SHIPS AND STEAM SHIPS OF 1,000 BRAKE HORSE-POWER

	Single-Screw Diesel 1,000 b.h.p.	Single-Screw Double-Reduction Geared 1,000 s.h.p.		Single-Screw Reciprocating 1,200 i.h.p.	
		Coal.	Oil.	Coal.	Oil.
Fuel, lbs. per h.p. an hour	·45	1·5	1·1	1·95	1·4
Consumption tons a day	4·82	16·1	11·8	25	18
Consumption tons for 30 days	145	483	354	750	540
Price of fuel a ton	£11	£5	£10	£5	£10
Cost of fuel for 30 days	£1,595	£2,415	£3,540	£3,750	£5,400
Lubricating oil consumption gallons a day	10	2	2	3	3
Lubricating oil, cost the gallon	5/-	5/-	5/-	5/-	5/-
Lubricating oil, cost for 30 days	£75	£15	£15	£22 10/-	£22 10/-
PERSONNEL—					
Chief engineer	1	1	1	1	1
Assistant engineers	3	2	2	2	2
Greasers	3	3	3	3	3
Firemen	—	3	3	3	3
Trimmers	—	3	—	3	—
Donkeyman	1	1	1	1	1
Electrician	1	—	—	—	—
Total engine-room staff	9	13	10	13	10
Total wages, 30 days	£191	£224 10/-	£195	£224 10/-	£195
Total keep, 30 days, at 7/- a day	£94 10/-	£136 10/-	£105	£136 10/-	£105
Total wages, fuel, oil, and keep 30 days	£1,955 10/-	£2,791	£3,855	£4,135 10/-	£5,722 10/-
Ratio	1	1·44	1·97	2·12	2·93
Net saving per annum of 200 days sailing, Diesel over steam	—	£5,570	£12,650	£14,520	£25,250

NOTE.—In addition to the above, the following savings are effected: Fuelling costs, less demurrage, additional cargo capacity, less accommodation needed for engine-room staff, no stand-by losses, less cleaning ship, higher average-speed in a sea-way, reduced fuelling appliances required, etc.

vessels of large size, but it will be noticed that a rapid increase is taking place in the tonnage of the motor ship, and that a higher speed is now attainable on a lower fuel consumption. One of the largest ships yet constructed, the *Gleniffer*, has a deadweight capacity of 10,000 tons, and is equipped with two sets of Diesel engines, having a combined power of 6,600 h.p. It has been estimated that this vessel can make 14 knots, and will be capable of running from London to Australia, and make more than half her return voyage without replenishing her oil supplies. The advantages of such a feat are obvious, both from the shipping company's point of view and from that of the trader. The motor ship, indeed, fulfils one of the vital conditions so essential to successful trade, namely, rapidity of transit, due not only to its speed, but to the fact that bunkering is eliminated during the voyage, which enables the vessel to arrive at its destination ahead of a steam-driven ship of even higher speed, and starting from port at the same time.

In order to express the various economic advantages attaching to the use of the motor ship I cannot do better than reproduce a table (shown on the opposite page) which was included in a paper read by Mr. James Richardson, of Messrs. William Beardmore & Co., Ltd., before the Institution of Engineers and Shipbuilders of Scotland, comparing the running costs of a Diesel ship with those of steam ships of 1,000 b.h.p. in each instance.

## CHAPTER VIII

### OILS FOR POWER PURPOSES

THE preparation and classification of oils for power purposes and chiefly for use in the internal combustion engine have not received the consideration and study they deserve, and which is essential if the supply of oils for this work is to be extended. Indeed, we have, at the present time, a spirit of almost resentment on the part of engineers that our chemists do not adapt the large variety of oils obtainable to the Diesel engine, and a similar attitude on the part of the latter, that the engine is not adapted to the use of any and every description of heavy oil. The responsibility rests, of course, on neither, but there can be no doubt that each side of the argument can contribute something towards the solution of the problem. The results would certainly be profitable to both and the respective industries. At the present time, the range of oils suitable for burning in the internal combustion is not large, and there are oils of certain grades and characteristics which are excluded by reason of some deficiency or of possessing some ingredient which the existing types of engines refuse to work on. This widening of the scope of suitable Diesel oils not only would relieve the drain on certain classes of oils, but would, at the same time, reduce their cost on account of eliminating the necessity of special distillation, storage and transport, which has now to be carried out.

The characteristics of an oil suitable for the Diesel type of engine have been classified by the majority of

manufacturers of these engines, though these do not altogether indicate very clearly the precise description of oil, or assist in their selection. The specific gravity of an oil is not by itself any criterion of its suitability in this connection, and, though the calorific value is an important point, there does not appear to be any relation between this factor and engine consumption. The one point on which there appears to be general agreement is flash point, for in all specifications it is fixed as having to exceed 150° F. Viscosity is a vital point where fineness of atomization is essential, and very viscous fuels require heating before introduction into the engine, a point which must be taken into account in selecting an oil, as some descriptions become sufficiently mobile once they are introduced into the piping system on the engine, but under normal atmospheric conditions they are of too high a viscosity to be handled in their cold state. An important consideration also is that of ash content which is regarded by some authorities as the most important factor in the selection of a Diesel engine oil, that is if freedom of trouble with the exhaust valve and unconsumed residue in the combustion chamber is to be secured. The ash content should not exceed .06 per cent. The petroleums of the world may be roughly divided into two distinct categories, namely, those having an asphalt base, and those having a paraffin base. The most suitable for the purpose under consideration are obviously those having a paraffin base, the largest supply of which is found in America, chiefly in Pennsylvania. The fields producing these are slowly becoming exhausted, and that is one reason why the Diesel engine should be so constructed as to employ any description of oil.

Petroleums possessing an asphalt base are generally disliked for use in this type of engine, as this constituent

will not distil, and, when heated, forms coke. On a long sea run this disposition has been the cause of serious trouble, while it detracts from the economic running of the engine. The undecided position of this aspect of the subject is indicated by the fact that in some quarters a proportion of 5 per cent asphalt was regarded as the maximum an oil should contain, while in other directions 15 per cent or even higher was stated as allowable.

Gas and tar oils are also in use on some engines, though the sources from which these are obtainable are not sufficiently extensive to enable a large supply to be relied on. The opinion of a high German authority on the latter of these descriptions was that, even if they were obtainable in sufficiently large quantities, they were not sufficiently consistent in quantity, and were the cause of too frequent break-downs during running. Tar oils and gas oils mixed in various proportions may be used, but this should not contain more than 25 per cent of the former.

This lack of standardization is also exhibited in the figures quoted in certain fuel oil specifications for Diesel engines.

The Anglo-American Oil Company gives the following for an oil suitable for use in engines where ignition is produced by the temperature due to compression—

Specific gravity at 60°.F . . . . .	.890-.910
Flash point . . . . .	175° F.
Cold test . . . . .	below 0° F.
Calorific value . . . . .	about 19,300 B.T.U.'s

No reference is made here to ash content or to viscosity, both of which are important points.



Another oil stated as being suitable for Diesel engines has the following characteristics—

Specific gravity at 20° C. (70° F.)	. . . . .	.910
Closed flash point	. . . . .	230° F.
Asphalt	. . . . .	8%
Water	. . . . .	.25%
Coke	. . . . .	5.0%
Ash	. . . . .	.02%
Sulphur	. . . . .	2.5%
Temp. of spontaneous ignition in oxygen	. . . . .	260° C.
Gross calorific value	. . . . .	19,200 B.T.U.

No mention is made, however, of the viscosity of the oil.

For the solid injection type of engine the following specification is recommended—

Specific gravity at 60° F. not above	. . . . .	.9
Viscosity at 70° F. seconds (Redwoods No. 1)	. . . . .	300
Flash point (close test) not below	. . . . .	150° F.
Sulphur, not exceeding	. . . . .	1%
Oil to be free from asphalt and ash.		

The specifications preceding this are for engines in which an injection is employed, and it is therefore apparent that the solid injection type restricts the descriptions of oils suitable for this special system.

In regard to tar oils, the following is stated to have been used with success. This is the specification laid down by the National Fuel Oil Company.

Sp. gr. 20° C. (50° F.)	. . . . .	below 1.10
Flash point (open)	. . . . .	above 150° F.
Coke	. . . . .	below 3%
Ash	. . . . .	.05%
Matter insoluble in benzine	. . . . .	25%
Total water by vol.	. . . . .	1.5%
Separated water	. . . . .	Nil

Another example typical of a fuel oil of paraffin base may be quoted—

Sp. gr. at 20° C. . . . .	.8887
Flash point (close) . . . . .	236° F.
Asphalt . . . . .	1.54%
Water . . . . .	Nil
Ash . . . . .	Traces
Coke . . . . .	—
Sulphur . . . . .	.635
Hydrogen . . . . .	12.55
Temp. of spontaneous ignition (Moore) . . . . .	209° C.
Gross calorific value . . . . .	19,404 B.T.U.
Net     "     " . . . . .	18,194     "

In tests carried out with mixtures of Mexican crude and Diesel oil in various proportions, it was shown that, if Mexican oil only was employed, the consumption would be 3 per cent higher than when burning Diesel oil only. This result would be more helpful if the characteristics of the Diesel oil used were given.

Another instance of the effect of oil mixtures in regard to viscosity and flash point is shown in the mixing of Mexican oil with Scotch shale oil. With 100 per cent shale oil the viscosity at 60° F. was  $.115 \times 10.3$  and flash point 237° F. With 50 per cent shale and 50 per cent Mexican the viscosity was .865, and flash point 167° F. The 100 per cent Mexican oil was 72, and the flash point 145° F. These figures need no comment, and this principle of intermixing is undoubtedly worthy of more serious consideration than has hitherto been given to it.

Even in the Fuel Oil Specifications laid down by the British and United States Admiralties there exist striking differences. In the former the flash point must not be lower than 175° F. (close test) and, in the case of oils of exceptionally low viscosity, the flash point must not be less than 200° F. The viscosity of the oil shall not exceed 2,000 secs. for an outflow of 50 cu. centimetres

at a temperature of 32° F. The American specification calls for a fuel oil having a flash point of not below 140° F., of a specific gravity of from .85 to .96 at 150 C. ; it should flow readily at ordinary atmospheric temperatures and under a head of 1 ft. of oil through a 4 in. pipe 10 ft. in length ; it should have a calorific value of not less than 18,000 B.T.U.'s per lb. In regard to sulphur the British specification allows up to 3 per cent, while the American places the limit at 1 per cent.

The data I have given and the general trend of the evidence produced reveal what an extraordinary diversity of practice exists throughout the world, and there appears to be little agreement among experts on this aspect of the subject. Yet, as has been indicated, its importance is great, for in it undoubtedly lies the future progress of the oil engine for marine purposes, and every effort should be made to introduce a far greater uniformity of practice in this respect. The statements made even by experts are frequently of a very vague character and do not assist in attaining that precision which one has a right to expect, and which alone can advance oil engine practice.

It is necessary also in concluding this brief review to utter a protest in regard to incorrect nomenclature of oils for use in Diesel engines. The term "crude" oil is frequently employed in referring to heavy oils. Crude oil is the liquid obtained direct from the well, and contains the lighter fractions as well as the heavier oils which have to be removed before the ordinary fuel oil is available. There are few crude oils which could be used in an oil engine in their natural state, and, even if this were possible, their use would involve the loss of highly valuable products. There appears, indeed, to be no definite practice in this terminology of oils for fuel purposes. In some instances, one finds the vague

terms fuel oil and Diesel engine oil employed, which are altogether too vague and convey nothing to the engineer. Valuable service would be rendered by one or other of our associations if this question of nomenclature were seriously taken up, and a well-defined classification formulated.

A table giving the ultimate analysis of various fuel oils is included in the appendix.

## CHAPTER IX

### OIL FOR POWER AND HEATING IN INDUSTRY

MORE extensive use has been made of oil for steam raising purposes and for heating in industrial processes than is generally recognized, for the reason that little publicity is given to installations of this description. Since the fuel conditions in this country, however, became aggravated by the prolonged coal strike, quite extensive resort has been had to oil for power stations and for steam raising purposes in manufacturing concerns. The equipment for such work is, however, of the simplest character, more so, of course, than that connected with its marine applications, and it is unnecessary here to enter into any detailed description of this aspect of the subject. One or other of the oil fuel systems in vogue is selected, and this, with the necessary tankage and piping is adapted to the boiler employed. This conversion is a work quite rapidly carried out, and in the majority of cases so arranged that a return to coal can be readily effected.

A more effective application of fuel oil is that in which it is used for the smelting of metals and the heating of semi-finished articles, such as nuts, bolts, rivets, etc. By reason of its cleanliness and its great and equal heat-giving properties oil should form an unequalled medium for these purposes, and where it has been adopted the results have shown how superior oil is to coal, and what a great improvement is made in the quality of the finished product. In order that this advantage may be realized the following figures are quoted, although since these results were obtained oil has decreased in value relatively to coal. The figures

refer to the cost of the fusion of 40 lbs. of brass in a Bickford Crucible Furnace.

With Coke—

$\frac{1}{4}$ cwt. of oven coke at 1s. 3d.	3·75
$3\frac{1}{2}\%$ waste of brass	8·4
Crucibles (20 charges at 5s. a crucible)	3
	<hr/>
	15·15
	<hr/> <hr/>

With Oil—

$\frac{3}{4}$ Gal. of oil at 2½d., say	2·0
$1\frac{1}{2}\%$ waste of brass	3·6
Crucibles (30 charges at 5s. a crucible)	2·0
	<hr/>
	7·6
	<hr/>

Conditions in every direction have, of course, changed since the date of this comparison, and, if anything, more in favour of oil. The chief points noticeable are the saving in waste metal, the increased number of charges put through, the reduction in the quantity of fuel used, and the consequent reduction in the cost of production.

For smithy work, and for the manufacture of sheet iron, the use of oil fuel has been found to afford great advantages, economic as well as metallurgical. Attempts have also been made to substitute oil for coke in the blast furnace, though there are apparent difficulties in this work which suggest obstacles to the practical possibility of its success. At any rate I have seen no record of its adoption as a commercial venture, and presumably the experiments did not justify its continuance. It may be interesting to quote the remarks made by a works manager when asked why he did not employ oil in the blast furnace. Some inventive genius may be able to solve the problem, and thus secure another wide application to the liquid fuel. "Solid carbon," he remarked, "plays a very important rôle, especially

in the upper level of the blast furnace shaft. Its function, especially with the fine ores, is largely to limber up the charge and allow the flow of gas to penetrate the charge evenly ; besides, incandescent carbon has certain functions to perform in the blast furnace, which are of a chemical nature, and which need not be discussed. If coke or charcoal should be entirely replaced by oil in the blast furnace, the charge would very likely become too dense to allow the combustion gases to escape freely." This is the problem confronting those who turn their thoughts towards the substitution of oil for the solid fuel in the blast furnace. At the same time, a system may be found which would overcome the difficulties, and if this were possible by the use of a pure fuel, such as oil is or can be rendered, there can be little doubt that the resultant product would be of a higher grade.

## CHAPTER X

### OIL STORAGE

THE capacities of the ocean storages of a country controls the quantity of oil consumed within it, though it does not indicate consumption, reserve supplies having to be kept in hand to avoid a shortage and to regulate prices.

The storage capacity available at the various centres in this country is given in the following table. Necessarily these figures must be approximate, but they represent fairly accurately the enormous storage existing, and indicate, indirectly, the vast requirements of the country of an imported product—

<i>District.</i>	<i>Capacity of Storage.</i>	
	<i>In Tons</i>	<i>In Gallons.</i>
London . . . . .	560,000	162,400,000
Manchester . . . . .	138,000	40,020,000
Bristol . . . . .	100,000	29,000,000
Hull . . . . .	70,000	20,000,000
Barrow . . . . .	50,000	14,500,000
Liverpool . . . . .	20,000	5,800,000
Newcastle and Sunderland . . . . .	20,000	5,800,000
South Coast . . . . .	15,000	4,350,000
Cardiff . . . . .	12,000	3,480,000
Ireland (chiefly Dublin and Belfast)	35,000	10,150,000
Scotland (East Coast) . . . . .	25,000	7,250,000
Totals	1,045,000	302,750,000

In connection with the ocean storage of the London district about three-fourths of this is owned by the great establishment of the London and Thames Haven



Oil Wharves, Limited. The system of unloading and distributing the oil to the various tanks adopted by this company is interesting, because of its simplicity and efficiency. The system has been termed the "telephone method," and consists of a series of "exchanges" equipped with pumps which direct the oil to the tank or group of tanks required. Briefly, this is effected by the installation of a main "exchange" ashore, which draws the oil from the tanker and transmits it to the pumping exchange connected by means of a pipe-line with the group of tanks which it is desired to fill. Each tank in the group has its own separate pipe which can be connected up with the pump independently of the others. When this tank has received its quantum of oil, the pipe is disconnected and linked up with another, and so on. All exchanges are connected consecutively, so that to load up the tanks in a distant part of the storage installation, the oil is passed through the necessary pumping "exchanges" until it reaches the "exchange" controlling the group of tanks which it is desired to fill.

Before and during the war the south coast, apart from London, had to rely on oil storage capacity of under 6,000,000 gallons, compared with Manchester having storage for 40,000,000 gallons, and Hull for 20,000,000 gallons. The Port of Bristol had a storage capacity of 29,000,000 gallons, or of 100,000 tons, which was unequal to the great and increasing demands made upon it. This port increased its tank storages from 21,190 tons in 1882 to close on 207,000 tons in 1919. The new scheme which is, however, being developed at this port not only will ease matters at the present time, but will allow for expansion for several years to come. The total area covered and definitely let for the purpose of new installations at the Royal

Edward, Avonmouth and Portishead docks, is over 50 acres, distributed among five important petroleum distributing companies. The Shell Marketing Company installation is situated at the Portishead dock, the Anglo-American and the British Petroleum Companies occupy sites in the Avonmouth dock, and the Anglo-Mexican Petroleum Company at the Royal Edward dock. In addition to these, the British Mexican Petroleum Company has engaged a site at the same dock. The Avonmouth dock is 2,180 ft. long, and 500 ft. in width, and has a depth of water on its sill of 38 ft. on mean spring tides, and 28 ft. on mean neap tides. The dock covers an area of 19 acres, and has a wharfage of over 1,600 yards. The Royal Edward dock has a length of 1,120 ft. and a width of 1,000 ft., covering an area of 30 acres, and having a wharfage of 3,730 ft. It has a depth of water of 46 ft. on mean spring tides, and 36 ft. on mean neap tides. This dock is connected with the Avonmouth by a cutting of 525 ft. long and 85 ft. wide. Portishead dock is 1,800 ft. long and 300 ft. wide, and has a length of wharfage of 943 yards. It is possible for vessels to enter this dock in any weather from the deep fairway of the Channel without the assistance of tugs. The Royal Edward dock has a length of 875 ft. and an entrance width of 100 ft., and the facilities of this dock are shown by the fact that one of the largest oil tankers was brought in for repairs and overhauled.

Important developments are also taking place at Southampton, which is becoming more and more a port of call for large Atlantic liners and other vessels. The British Mexican Petroleum Company, the Anglo-American Oil Company, and the Agwi Petroleum Corporation are all establishing storage facilities at this port. The British Mexican Company have a wharf at Itchen, and have bunkered many large vessels by means



FIG. 18  
OIL STORAGE DEPOT OF BRITISH PETROLEUM CO.  
AT AVONMOUTH

of their barges, which go alongside vessels wherever they may be. The company owns seven acres of land which is being converted into an oil fuel depot and bunkering station. The total capacity of the tanks will be 24,000 tons, and these are connected to the jetty at the mouth of the Itchen by means of pipe-lines. The channel when completed will have a depth of 30 ft., allowing oil tankers to reach the jetty. From here the oil is pumped into the tanks or in the case of bunkering a vessel in Southampton water the oil is transferred from the tanks to lighters which carry the oil out to the vessel.

The Agwi Petroleum Company's facilities included several berths, each of which will consist of a wharf of from 80 to 100 ft. long, and, when completed, it will be possible to berth tankers of 15,000 tons.

An extensive oil fuel depot and bunkering arrangements have been installed by the British Mexican Company on the Clyde. The site of the depot occupies a considerable area, extending from the North British Railway Company's line to low-water mark of the river frontage. The disadvantage of being unable to turn a ship in the navigable channel of the river after receiving her bunkers has been overcome by the construction of a basin. This basin is 600 ft. in length and 200 ft. in breadth. Four 10 in. pipe-lines heated by internal steam pipes run out from the tanks to the heads of four specially-constructed jetties, which project from the east side of the basin, and are so designed as to accommodate vessels at the most convenient angles, having regard to prevailing winds and tides. The storage capacity of the tanks at the station is 20,000 tons, and oil is pumped down the pipe-line by two of the largest pumps which Messrs. G. & J. Weir have yet constructed, enabling a ship with sufficiently large pipe

connections to receive oil at the rate of 400 or 500 tons per hour. The unique arrangement of valves in the power-house makes it possible for two or three ships to be bunkered simultaneously in the basin, and at the same time for a tanker to pump oil up to replenish the stock in the storage tank. The company have made arrangements for a satisfactory means of bunkering boats at the tail of the bank, or at any point in the Clyde. For this purpose a number of steel barges with capacities varying from 300 to 1,200 tons have been provided.

In the storage of the large quantities of fuel oil during the war extensive concrete reservoirs were built at Rosyth, designed for a total capacity of 60,000,000 gallons. Although this type of reservoir had been employed in oil-producing countries abroad, this was the first occasion of their use in this country, and they were built partly in mass concrete and partly in reinforced concrete. The utmost care was taken to lay the concrete so that there might be a minimum of cracks, but despite all this it was found necessary to cover the floor with 6 in. of concrete having two layers of expanded metal in it. The mix of this further layer was  $2\frac{1}{2} : 1\frac{1}{2} : 1$ , other mixes being  $7 : 3 : 1$ , the stone being broken to pass through a 2 in. ring for mass work, and the fine concrete for facing was composed of a mix of  $3 : 1\frac{1}{2} : 1$ , the stone being broken to pass through a  $\frac{1}{2}$  in. ring. The usual form of holder is a cylindrical steel tank, which may be obtained in various standard sizes. A typical example of the 2,000,000 gallon tank is 114 ft. 6 in. diameter by 32 ft. high, with a bottom plate of  $\frac{1}{4}$  in., the first or lowest course of all plates being  $\frac{5}{8}$  in. ; a somewhat heavier type, having the same capacity, is 112 ft. diameter by 32 ft. 9 in. high, and having  $\frac{3}{8}$  in. bottom plates and  $\frac{11}{16}$  in. plates for the first course.

In both cases the roof, which is of the lightest construction, is supported from a central tower. An obvious advantage of steel tanks is that they occupy very little space compared with their capacity, and in the case of a fire it is seldom that a whole tank collapses. On the other hand, an advantage of concrete tanks is that the oil contained will not be affected to a very great extent by atmospheric temperature fluctuations, so that the amount of steam heating required will remain fairly constant during any one season of the year.

With the great increase in the adoption of oil vessels, extensive arrangements have had to be made for bunkering vessels with oil at various ports along the main trade routes. This chain of storage depots has now become so world-wide, and is so well organized, that wherever an oil-driven vessel may be she can replenish her fuel supplies as readily as coal burning ships can bunker.

The following are the chief ports where oil depots are now established—Adelaide, Alexandria, Amoy, Amsterdam, Antwerp, Augusta (Sicily), Avonmouth, Birkenhead, Barrow-in-Furness, Belfast, Bremerhaven, Batavia, Bangkok, Buenos Aires, Bilbao, Balik Pappan, Bombay, Brixham, Bizerta, Bergen, Baltimore, Bayonne (New Jersey), Barbados, Boston, Cardiff, Constanza, Colombo, Calcutta, Canton, Capetown, Campana, Callao, Curacao, Copenhagen, Christiania, Dublin, Enna, Foynes (near Limerick), Foochow, Grangemouth, Glasgow, Genoa, Gothenburg, Galveston, Hull, Hamburg, Hong Kong, Hangkow, Halifax (Canada), Havana, Honolulu, Iquique, Jacksonville, Kobe, Karachi, London, Las Palmas, Lisbon, Manchester, Mombassa, Madras, Melbourne, Monte Video, Macassar, Manila, Montreal, Noworowik (Batun), Nagasaki, New York, New Orleans, Newcastle, Norfolk, Va Oregon, Port Edgar (Firth of

Forth), Portsmouth, Purfleet, Plymouth, Penang, Portland, Port Said, Prince Rupert, Philadelphia, Port Arthur, Providence, Pernambuco, Rouen, Rangoon, Rio de Janeiro, Rotterdam, Sunderland, St. Louis (France), Suez, Sorenbar, Surabaya, Singapore, Saigon, Swatow, Shanghai, Santos, St. Thomas, St. Vincent, San Francisco, Stockholm, Southampton, Savona, San Juan, San Pedro, Thames Haven, Tampico, Tuxpam, Trinidad, Tampa, Vancouver, Vera Cruz, Valparaiso, Venice, Yokohama.

## CHAPTER XI

### THE DISTRIBUTION OF OIL

THE distribution of oil may be said to commence at the well. When the crude oil is raised, either by means of a boiler, which is a cylindrical iron receptacle from 12 to 14 ft. in length, and of less diameter than the bore-hole, and is lowered into the oil, filled and raised again, or by pumping, or if the well is a gusher, it is directed into pipes leading to tanks in which it is stored. From these tanks the crude oil is conveyed to the refinery also by pipe-line. The crude is there split up into its various products, which are stored awaiting distribution.

When the producing fields are long distances from the shipping port, as in the case of Baku and the Persian fields, overland pipe-lines are laid, usually of larger diameter than those employed on the field. The Russian oil-producing centre possesses a pipe-line about 650 miles in length, which is equipped at intermediate points with powerful Worthington pumps which drive the oil to Batum, the European shipping port of the Black Sea. The Persian oil-fields are tapped by a 600-mile pipe-line by which the petroleum is conveyed to storage tanks on the Persian Gulf. In the case of the Mexican fields the oil products are drawn from the storage tanks, and by means of a pipe-line are carried to the tank steamer lying some distance at sea, the formation of the coast not allowing the vessels to come close into shore. In the United States, the length of pipe-line running from the fields to the collecting centres runs into several thousand miles, and is the most perfect system of pipe-line in the world. This method of transport by



pipe-line is the most effective, the simplest, and, in the long run, by far the cheapest. There is, of course, a certain amount of waste through leakage, but this defect is inherent in practically every form of transport.

From the tanks containing the distilled products the various oils for foreign distribution are loaded into tank steamers and conveyed to tank storages at the ports of destination. For distribution in the country of production railway tank wagons are employed, and for local distribution from local centres the road tank wagon and the water wagon for carrying oils in small quantities are used.

The tank steamer by means of which the petroleum products are conveyed from oil-field ports to foreign markets is one of those modern methods which have contributed very largely to the extended use of oil for various purposes. It has been the means of saving millions of gallons of oil by reducing wastage, and by carrying such large quantities in bulk has reduced the cost of transport and enabled prices to be kept at a reasonable figure. Previous to the adoption of the bulk method of conveying oil from the fields to the importing country, the traffic was carried on by means of barrels and cases, and at the present time a considerable quantity of oil is dispatched to the Far Eastern markets in the latter form of receptacles. An enormous amount of wastage occurred in the use of wooden barrels, and in order to obviate this a steel barrel was introduced, and is now very extensively used. Barrel transport is now, however, almost entirely restricted to the distribution of lubricating oils. It is estimated that approximately 1,500,000 million barrels are in service in this direction.

Since the inception of the tanker its size has been greatly increased. When the Eagle Oil Transport Company laid down its programme it included vessels

capable of carrying 10,000 tons of oil as a single cargo, as well as a number of vessels having a dead-weight capacity of 15,000 tons. At that time these were the largest afloat, but this company subsequently launched a tanker having a carrying capacity of over 18,000 tons. Great credit must be given to Sir Marcus Samuel, who initiated this system of oil transport from the Borneo fields to this country, and, in order to obviate the necessity of sending the "Shell" tankers back empty, a special means of cleansing the oil tanks was devised, which enabled even the most susceptible cargo to be loaded into the tanks.

In addition to the ocean storages referred to, there are a very large number of subsidiary storages arranged at convenient places inland for local distribution, the oil being conveyed from the main storage by means of railway tank wagons and motor vehicles. In addition to these, however, there are a large number of subsidiary storages on the coast, which are fed by means of coastal boats, also from the ocean storage. In order to meet the enormous and widespread demand for the large variety of oils consumed in this country for purposes of transport and industry, thousands of small storages and agencies exist throughout the kingdom. It is estimated that the number of tank wagons engaged in carrying oil in this country is about 3,000, and in distributing the various oils to agencies an extensive fleet of motor wagons and horse-drawn vehicles is provided, delivery in these cases being in the form of barrels and tins. It is estimated that there are about 300 motor wagons on the road for oil distributing purposes in this country.

The greater portion of the oil imported to Manchester and other parts is carried in bulk by tank steamers, although considerable quantities of barrelled oil are



FIG. 19  
UNLOADING TANK STEAMER

brought to the port of Manchester by the regular liners from North America. The facilities at some of the installations include special conveyors for the quick and economical handling of barrelled oil from ship into storage depot alongside. The oil is distributed from these storages by rail and by road vehicles, while there exists water transit by means of tank barges over the inland canal systems of Lancashire, Yorkshire, and the Midlands. Hitherto the policy of the directors of the Manchester Ship Canal Company has been to prohibit the passage over the waterway of petroleum spirit or other oils flashing at less than 73° Fahr., but, in order to meet the request of the principal firms who desired to establish depots on the waterway for low flashing oils, the Canal Authorities decided to permit petroleum spirit, etc., to be imported into the lower section of the Canal near Eastham. The facilities to be granted for dealing with the traffic include the construction of a dock at Stanlow Quarry, with an entrance and turning basin, in which tank steamers laden with such commodities could be accommodated. The dock would be closed by means of a floating caisson to prevent, in case of accident, the escape of spirit into the Ship Canal.

The last ten years have shown remarkable growth in the number of oil-tankers in use, no fewer than over 500 vessels having been put into service during this period. The number of tankers now in use throughout the world is approximately 750, representing close on 4,000,000 tons. It is somewhat difficult to ascertain the annual carrying capacity of this fleet, but, if we allowed a round trip every two months, this would enable 24,000,000 tons of oil to be transported. There are, however, a large number of vessels, which could accomplish more journeys than this each year, and, allowing for these, it is probable that the total quantity of oil

transported from the various sources of production approximates more nearly to 30,000,000 tons.

The bulk of these oil-carrying vessels are constructed on the Isherwood longitudinal system, the proportion amounting to about 86 per cent. Another system of oil tanker construction was introduced about a year ago, which deserves reference. In this method of construction the main transverse frames and beams include ordinary rolled sections spaced in the ordinary way, but they are simple units not supplemented by floors, web frames, or any such additional material and obstruction in common use. Uniformity of stresses and sufficient strength are obtained in the frame members by the introduction of built longitudinal members running from and connected to the transverse boundary bulkheads at the ends of each compartment or hold. The longitudinal members consist of the vertical keelsons along the bottom, which are connected to the transverse frame bars and the shell plating of the ship, and of the horizontal side stringers or shelves, which are disposed along the sides of the vessel, and are similarly connected.

By virtue of this design ordinary transverse frames and beams are used, but floors are entirely dispensed with, and the usual deep vertical webs may be either dispensed with or reduced in number, the necessary strength being secured by the introduction of deep keelsons extending and connected to the bottom plating and by horizontal stringers or shelves suitably spaced and arranged and extending, like the keelsons, the full length of each hold to the boundary transverse bulkheads to which they are securely connected. The frames may be in one length from the deck to the centre keelson of the ship, and suitably connected thereto, or cut at one or more of the other keelsons, and their ends suitably connected

thereto, uniform stress on the frames being obtained by a suitable disposition and arrangement of the keelsons and the stringers. Advantage is taken of the close spacing of the transverse bulkheads in these vessels, and of the great strength provided by the continuous longitudinal centre line bulkhead to spring fore and aft girders along the bottom and under the deck, and connecting these to the transverse bulkheads ; and by fitting strong stringers or horizontal girders round the sides and bulkheads, forming the whole into a series of box-like structures, adequately strengthened by these horizontal and vertical belts of deep girders. The distinguishing characteristics of the system of construction are its extreme simplicity and the reduction of the different sizes of sections involved, the general uniformity in length and dimensions of these, the speed and facility with which the whole ship's structure can be put together, and the consequent reduction of the amount of labour and time involved. There are further advantages of openness and accessibility of all the holds and spaces, and the minimum amount of work and time involved in the event of damage repairs being required in any part of the structure.

Another aspect of tanker construction is that the piping essential to efficient work is of a most complicated character, and the difficulties of attending properly to this installation are obvious. With the object of simplifying this work, as well as of improving generally the construction of merchant vessels, a device known as the Duct Keel was introduced. This form of keel is said to provide a solution of the problems which have to be faced in arranging for the necessary suction and filling systems, and also for the heating pipes. On the vessels now under construction, in which this system is adopted, practically the whole of the oil fuel and bilge systems

are accommodated in the box keel, and the saving in the cost of the installation is very marked, while the accessibility of the piping under all conditions of loading should prove of great convenience. The difficulty of attending on piping systems which run either through oil fuel tanks or through the bilges into oil fuel tanks is very considerable, and this is stated to be entirely eliminated when the piping systems are run through a duct keel.

# APPENDIX

## SPECIFIC GRAVITY AND WEIGHT PER CUBIC FOOT OF PETROLEUM REFUSE AT VARIOUS TEMPERATURES

Water = 1.0000 specific gravity, at 17½° Cent. = 63½ Fahr.

Centigrade	Temperature		Specific Gravity.	Weight in b. the cubic foot.
	Reaumur.	Fahrenheit		
0	0.0	32.0	0.9110	56.61
1	0.8	33.8	0.9103	56.55
2	1.6	35.6	0.9097	56.50
3	2.4	37.4	0.9091	
4	3.2	39.2	0.9085	56.42
5	4.0	41.0	0.9078	56.36
6	4.8	42.8	0.9072	
7	5.6	44.6	0.9066	56.30
8	6.4	46.4	0.9060	
9	7.2	48.2	0.9053	56.20
10	8.0	50.0	0.9047	56.14
11	8.8	51.8	0.9041	
12	9.6	53.6	0.9034	56.11
13	10.4	55.4	0.9028	56.05
14	11.2	57.2	0.9022	
15	12.0	59.0	0.9016	55.99
16	12.8	60.8	0.9009	55.92
17	13.6	62.6	0.9003	
18	14.4	64.4	0.8997	55.84
19	15.2	66.2	0.8991	
20	16.0	68.0	0.8984	55.81
21	16.8	69.8	0.8978	55.74
22	17.6	71.6	0.8972	
23	18.4	73.4	0.8965	55.68
24	19.2	75.2	0.8959	55.62
25	20.0	77.0	0.8953	
26	20.8	78.8	0.8947	55.55
27	21.6	80.6	0.8940	
28	22.4	82.4	0.8934	55.48
29	23.2	84.2	0.8928	55.43
30	24.0	86.0	0.8922	
31	24.8	87.8	0.8915	55.37
32	25.6	89.6	0.8909	55.30
33	26.4	91.4	0.8903	
34	27.2	93.2	0.8896	55.24
35	28.0	95.0	0.8890	



## CONVERSION TABLE FOR DEGREES BAUMÉ

Degrees Baumé.	Degrees Sp. Gr.	Lb. in 1 gal. (American).	Degrees Baumé.	Degrees sq. Gr.	Lb. in 1 gal. (American).
10	1.0000	8.33	43	.8092	6.74
11	.9929	8.27	44	.8045	6.70
12	.9859	8.21	45	.8000	6.66
13	.9790	8.16	46	.7954	6.63
14	.9722	8.10	47	.7909	6.59
15	.9655	8.04	48	.7865	6.55
16	.9598	7.99	49	.7821	6.52
17	.9523	7.93	50	.7777	6.48
18	.9459	7.88	51	.7734	6.44
19	.9395	7.83	52	.7692	6.41
20	.9333	7.78	53	.7650	6.37
21	.9271	7.72	54	.7608	6.34
22	.9210	7.67	55	.7567	6.30
23	.9150	7.62	56	.7526	6.27
24	.9090	7.57	57	.7486	6.24
25	.9032	7.53	58	.7446	6.20
26	.8974	7.48	59	.7407	6.17
27	.8917	7.43	60	.7368	6.14
28	.8860	7.38	61	.7329	6.11
29	.8805	7.34	62	.7290	6.07
30	.8750	7.29	63	.7253	6.04
31	.8695	7.24	64	.7216	6.01
32	.8641	7.20	65	.7179	5.98
33	.8588	7.15	66	.7142	5.95
34	.8536	7.11	67	.7106	5.92
35	.8484	7.07	68	.7070	5.89
36	.8433	7.03	69	.7035	5.86
37	.8383	6.98	70	.7000	5.83
38	.8333	6.94	75	.6829	5.69
39	.8284	6.90	80	.6666	5.55
40	.8235	6.86	85	.6511	5.42
41	.8187	6.82	90	.6363	5.30
42	.8139	6.78	95	.6222	5.18

The Sp. Gr.  $\times 10$  = weight in pounds in imperial gallon.

The Baumé scale being entirely arbitrary, there are several different values given by different authorities, but the above are those given by Mr. Tagliabue, of New York, the principal maker of hydrometers in the United States.

(W, D, B.)

To ascertain the Sp. Gr. of an oil of certain degrees Baumé, add Baumé to 130 and divide into 140,

## EXPANSION OF PETROLEUM

The co-efficient of expansion varies with the specific gravity of the oil, and for burning oils between s. g. .795 and .825 is about—

For 1° Fahrenheit	.0004	or	$\frac{1}{250}\%$
„ 1° Centigrade	.00072	or	$\frac{1}{11}\%$
„ 1° Reaumur	.0009	or	$\frac{1}{9}\%$

For benzines it is higher, being about .00045 for each degree F. ; whilst for solar and lubricating oils it is lower, being about .00038 for solar, and from that figure to .00035 for the heavier lubricating oils.

## EXAMPLES

If the specific gravity of oil is .800 at 60° F., what would it be at 85° and 32° ?

	60°	=	.800		60°	=	.800
	85°				32°		
	<hr/>				<hr/>		
Difference	25°				28°		
×	.0004	=	.010	×	.0004	=	.0112
			<hr/>				<hr/>
			.790				.8112
			<hr/>				<hr/>

What would be the increase of bulk in 50,000 cub. ft. of oil if the temperature rose from 60° to 85° F. ?

Difference of temperature = 25° ×  $\frac{1}{250}$  =  $\frac{25}{250}$  or  $\frac{1}{10}\%$

$$\frac{50,000 \times 5}{4 \times 100} = 625 \text{ cub. ft.}$$

Therefore the total volume of the oil at the increased temperature (85°) would be 50,000 + 625 = 50,625 cub. ft.

## CONVERSION OF CENTIGRADE TO FAHRENHEIT

The three thermometric scales are: Celsius or Centigrade; Réaumur, still used in Russia; and Fahrenheit. The formulæ for converting one to another are—

To convert C to R	.	.	.	$C^\circ \times \frac{4}{5} = R^\circ$
R to C	.	.	.	$R^\circ \times \frac{5}{4} = C^\circ$
C to F	.	.	.	$(C^\circ \times \frac{9}{5}) + 32$
F to C	.	.	.	$(F^\circ - 32) \times \frac{5}{9}$
F to R	.	.	.	$(F^\circ - 32) \times \frac{4}{9}$
R to F	.	.	.	$(R^\circ \times \frac{9}{4}) + 32$

## THERMAL UNITS

The British thermal unit is the amount of heat required to raise 1 lb. of pure water 1° F., or from 39.1° F. to 40.1° F.

The large calorie (French unit) is the amount of heat required to raise 1 kilogram of water through 1° C.

The small calorie (scientific unit) is the amount of heat required to raise 1 gramme of water from 0° C. to 1° C.

The pound centigrade unit is the amount of heat required to raise 1 lb. of water from 0° C. to 1° C.

British Thermal Unit (B.T.U.)	Large Calorie (Ca)	Small Calorie (Ca)	Lb. Centigrade Unit (Lb. C.U.)	Foot lbs.
1	0.252	252	0.555	778
3.9682	1	1,000	2.2046	3,080
0.003968	0.001	1	0.002046	3.08
1.8	0.4536	453.6	1	1,397

#### DETERMINING B.T.U.'s

Method to determine the approximate B.T.U.'s per pound of oil, various gravities, is to reduce the constant 18650 and deduct 10 from Baumé gravity; multiply this by 40, adding result to the constant, which will give the B.T.U.'s in a pound of oil of that gravity. Thus—What is the heat value of 27° Baume fuel oil?  $27 - 10 = 17 \times 40 = 680$ . Add constant  $18,650 = 19,330$ . To get the heat values a gallon, multiply by pounds a gallon in various gravities.

#### CALORIFIC CAPACITY OF A FUEL

Dulong, the French chemist, employs the following formula for ascertaining the approximate calorific capacity of a fuel—Calories =  $x = 8,080 C + 34,500 (H - \frac{O}{8})$  when C = weight of carbon, H = weight of hydrogen, and O = weight of oxygen in 1 kilo of fuel; or, if expressed in B.T.U.'s,  $B.T.U. = x = 14,500 C. + 62,100 (H - \frac{O}{8})$  where  $x$  = the thermal units C = weight of carbon, H = weight of hydrogen, and O = weight of oxygen in 1 lb. of the fuel. The Verein Deutscher Ingenieure use a modified formula:  $x = 8,100 C. + 29,000 (H - \frac{O}{8}) + 2,500 S - 600 E$ , thus allowing for the sulphur and for the hygroscopic water and for the fact that the hydrogen products are produced as steam.

#### CALORIFIC VALUE AND EVAPORATIVE POWER OF COAL

Coal (from several Samples)	Specific Gravity.	Ash.	Moisture.	B.T.U.	Lbs. of Water.
Welsh . . . . .	1.315	4.1	4.9	14,470	14.98
Newcastle . . . . .	1.256	5.7	3.8	14,432	14.94
Derby and Yorks . . . . .	1.292	10.3	2.6	13,582	14.06
Lancashire . . . . .	1.273	9.5	4.6	13,552	14.03
Scotch . . . . .	1.260	9.7	4.0	13,804	14.29
Average British . . . . .	1.279	7.87	4.0	13,968	14.46

SPONTANEOUS IGNITION OF LIQUID FUELS  
(H. MOORE)

	Sp. Gr.	Ignition Temperatures	
		In Oxygen Degrees.	In Air. Degrees.
Crude Petroleum (Egypt) . . .	.851	260	—
Digboi Oil (Assam) . . . . .	.890	261	384
Anglo-Persian Oil Co.'s Oil . . .	.894	254	408
Anglo-American Fuel Oil . . . . .	.900	269	430
Anglo-Mexican Oil . . . . .	.908	259.5	417
Crude Petroleum (Borneo) . . . . .	.939	269	380
Mexican Fuel Oil . . . . .	.948	259.5	424
Crude Petroleum (Trinidad) . . . . .	.950	274	424
„ „ (California) . . . . .	.952	264	—
„ „ „ . . . . .	.961	262	420
Oil Engine Oil (Broxburn) . . . . .	.768	253	333
Coke Oven Tar Oil (Simon-Carves)	1.046	478	—
Tar (Low Temperature Carboniza- tion) . . . . .	.987	307	508
Oil Gas Tar (Beckton) . . . . .	1.077	415	—
Horizontal Retort Tar (Stockport). . . . .	1.123	454	—
Coke Oven Tar (Coppee) . . . . .	1.140	488	—
Blast Furnace Tar . . . . .	1.172	498	—

ANALYSIS OF FUEL OILS

<i>Kind of Fuel.</i>	<i>Mexican.</i>	<i>Persian.</i>	<i>Texas.</i>	<i>Borneo.</i>	<i>California.</i>	<i>Rumania.</i>
Carbon . . . . .	83.52%	86.6%	86.30%	86.74%	84.43%	87.11%
Hydrogen . . . . .	11.68%	12.3%	12.22%	10.67%	10.99%	11.87%
Sulphur . . . . .	3.27%	—	1.33%	0.03%	0.59%	0.16%
Nitrogen . . . . .	1.37%	—	0.06%	0.05%	0.65%	0.15%
Oxygen . . . . .	—	1.1%	—	—	—	—
Water . . . . .	—	—	0.09%	2.51%	3.34%	0.71%
Ash . . . . .	0.16%	—	—	—	—	—
Calorific Value in B.T.U. . . . .	18,500 about	18,500	18,400	18,830	18,806	19,320
Specific Gravity at 60° F. . . . .	.950 above 150° F.	.925 above 150° F.	0.922 above 160° F. 215° F.	0.9628	0.962	0.935
Flash Point . . . . .	—	—	—	225° F.	228° F.	244° F.
Ignition Point . . . . .	—	—	—	294° F.	258° F.	298° F.

# INDEX

- AIR compressors for Diesel engines, 77  
American railways, oil fuel on, 54; consumption on, 55  
Anglo-American Oil Co.'s engine oil specification, 90  
Asphalt base oils for Diesel engines, 89
- BARRELS, oil transport in, 107  
Blast furnaces, inutility of oil for, 96  
Boiler design for oil firing, 46  
British railways on oil fuel, 57  
B.T.U.'s, determining, 117  
Bunkering, oil, 48, 51  
— depots, oil, throughout the world, 104  
Burmeister & Wain Diesel engine, 62
- CALORIFIC values of different oils, 7; value of oil and coal, 39; capacity of a fuel, 117; value of coal, 117  
Castings for Diesel engines, 78  
Characteristics of oils for Diesel engines, 88  
Coal *v.* oil, 1; an inefficient power producer, 12; problem, the, 13; calorific value and evaporative power of, 117  
Comparison of two- and four-cycle engines on ships, 75  
Consumption of oil on an Indian railway, 58; on Diesel-driven ship, 82-84  
Conversion table for degrees Baumé, 115; of Centigrade to Fahrenheit, 116
- DETERMINING B.T.U.'s, 117  
Diesel engines, measurements of chief types of, 74. *See also* Internal Combustion Engines  
Distillation of oil from coal, 14  
Distribution of oil, 106  
Duct keel, the, 112
- ECONOMY of oil fuel on locomotives, 59  
Economic advantages of the motor ship, 81, 87  
Evaporation of water by oil, 43  
Evaporative power of coal, 117  
Expansion of petroleum, 116
- FOUR-CYCLE type of I.C. engine, the, 62  
Fuel consumption of Diesel engines, 75, 76, 84; economy over coal for locomotives, 59  
— oil available from various oils, 6; specifications of British and American Admiralties, 92  
— supplies, provision of, 1  
— values on coal-fired and Diesel driven ships, 82
- GAS and tar oils for Diesel engines, 91
- HOUSE production of fuel oils, 11  
Hot-bulb type of engines, 79
- INDIAN railway, oil fuel on an, 58  
Internal combustion engine, the, 61; progress of, 78

- Internal combustion engine :  
 Burmeister & Wain, the, 62 ;  
 Sulzer two-cycle, the, 65 ;  
 Camellaird-Fullager, the, 67 ;  
 Doxford opposed piston, the,  
 69 ; Vickers solid injection,  
 the, 70 ; Still, the, 73
- LABOUR on oil-fired ships, 48
- Liquid fuels, spontaneous igni-  
 tion of, 118
- Locomotives, advantages of  
 oil-fired, 53
- London and North-Western  
 Railway, oil fuel on, 59
- " MAJESTIC," R.M.S., on oil  
 fuel, 49
- Material, carbonaceous, avail-  
 able, 15
- Measurements of chief types of  
 Diesel engines, 74
- Mexican productivity, 2
- Mexico, unexploited lands of, 9
- Motor ship, the, 81 ; and  
 steam ship, running costs  
 of, the 86 ; economic advan-  
 tages of the, 87
- NOMENCLATURE of oils, 93
- OIL-BURNING installation, ease  
 of manipulating, 39 ; advan-  
 tages of, 40
- Oil consumption on ships, 41  
 — deposits, undeveloped, 5  
 —, economies in producing, 9
- Oil-firing, direct, 18
- Oil-fuel burning, early experi-  
 ments in, 18 ; burning, chief  
 methods of, 19
- Oil fuel on ships, 41 ; advan-  
 tages of, 47 ; on railways,  
 53 ; on American railways,  
 54 ; on Mexican railways,  
 56 ; on the Southern Pacific  
 Railroad, 57 ; on an Indian  
 railway, 58 ; on the L. &  
 N.-W. Railway, 59
- Oil fuels, spontaneous igni-  
 tion of, 118
- Oil-fuel system : Holden, the,  
 20 ; Kermode, the, 22 ;  
 Korting, the, 24 ; Orde  
 steam jet, the, 26 ; Rusden-  
 Eeles, the, 26 ; Thompson,  
 the, 26 ; Thornycroft, the,  
 29 ; Wallsend, the, 30 ;  
 White low pressure, 30 ;  
 J. Samuel White, 32 ; Bab-  
 cock & Wilcox, the, 34 ;  
 Unolco, the, 34
- Oil mixtures for Diesel engines,  
 92  
 —, potential, supplies, 8  
 — production, the world's,  
 5  
 — requirements of Great  
 Britain, 13  
 — storage, 98 ; during the  
 war, 99  
 — supply, the world's, 2  
 —, yield of, from coal, 15,  
 16  
 — for power and heating in  
 industry, 95
- Oils for power purposes, 88
- PIPE-LINES in Russia and  
 Persia, 106
- Position of burners on loco-  
 motives, 60
- Production of Borneo, Mexico,  
 and Persia, 4
- Progress of internal combus-  
 tion engine, 78
- RADIUS of action of ships  
 increased, 41 ; of motor ship,  
 the, 87
- Railways, oil fuel on, 53
- Rosyth, oil storage at, during  
 the war, 103
- Running costs of Diesel and  
 steam ships, 86
- SEMI-DIESEL engines, 79
- Ships, oil fuel on, 41

- Shortage of oil not due to lack of supply, 3
- Smelting metals by oil, 95
- Southern Pacific Railroad, oil fuel on, 57
- Specifications for Diesel oils, 90 *et seq.*
- Specific gravity and weight of petroleum refuse, 114
- Steam, loss of, on coal-fired ships, 50
- Steamship and motor ship, running costs of, 86
- Storage, oil, 98
- Storages, subsidiary, 108
- Suitable oils for Diesel engines, widening scope of, 88
- Supply of oil, fundamental factors in, 3
- TANK steamer for transporting oil, 107
- Tar oils for Diesel engines, 90
- Thermal efficiency, increased, of oil, 42; units, 116
- Types of internal combustion engines, 61
- UNITED States, consumption of fuel oil in, 46; productivity of, 4
- WATER-TUBE boilers for oil-burning ships, 46



AN ABRIDGED LIST OF  
**TECHNICAL BOOKS**

PUBLISHED BY

**Sir Isaac Pitman & Sons, Ltd.**

(Incorporating WHITTAKER & CO.)

PARKER STREET, KINGSWAY,  
 LONDON, W.C.2

The prices given apply only to the British Isles, and are  
 subject to alteration without notice.

A complete Catalogue giving full details of the following  
 books will be sent post free on application.

ALL PRICES ARE NET.

	<i>s.</i>	<i>d.</i>
ACCUMULATORS, MANAGEMENT OF. Sir D. Salomons	7	6
AEROFOILS AND RESISTANCE OF AERODYNAMIC BODIES, PROPERTIES OF. A. W. Judge . . .	18	0
AERONAUTICS, ELEMENTARY. A. P. Thurston . . .	8	6
AERONAUTICAL ENGINEERING, TEXT-BOOK OF. A. Klemin . . . . .	15	0
AEROPLANE DESIGN AND CONSTRUCTION, ELEMENTARY PRINCIPLES OF. A. W. Judge . . .	7	6
AEROPLANES, DESIGN OF. A. W. Judge . . . . .	14	0
AEROPLANE STRUCTURAL DESIGN. T. H. Jones and J. D. Frier . . . . .	21	0
AIRCRAFT AND AUTOMOBILE MATERIALS—FERROUS. A. W. Judge . . . . .	25	0
AIRCRAFT AND AUTOMOBILE MATERIALS—NON- FERROUS AND ORGANIC. A. W. Judge . . . . .	25	0
ALTERNATING CURRENT BRIDGE METHODS OF ELECTRICAL MEASUREMENT. B. Hague . . . . .	15	0
ALTERNATING-CURRENT CIRCUIT, THE. P. Kemp. . . . .	2	6
ALTERNATING CURRENT MACHINERY, DESIGN OF. J. R. Bait and R. D. Archibald . . . . .	30	0
ALTERNATING CURRENT MACHINERY, PAPERS ON THE DESIGN OF. C. C. Hawkins, S. P. Smith, and S. Neville . . . . .	21	0

	<i>s.</i>	<i>d.</i>
ALTERNATING-CURRENT WORK. W. Perren Maycock	10	6
ARCHITECTURAL HYGIENE. B. F. and H. P. Fletcher	10	6
ARITHMETIC OF ALTERNATING CURRENTS. E. H. Crapper	4	6
ARITHMETIC OF ELECTRICAL ENGINEERING. Whitaker's	3	6
ARITHMETIC OF TELEGRAPHY AND TELEPHONY. T. E. Herbert and R. G. de Wardt	5	0
ARMATURE CONSTRUCTION. H. M. Hobart and A. G. Ellis	25	0
ARTIFICIAL SILK AND ITS MANUFACTURE. J. Foltzer. Translated by S. Woodhouse	21	0
AUTOMOBILE AND AIRCRAFT ENGINES. A. W. Judge	30	0
AUTOMOBILE IGNITION AND VALVE TIMING, STARTING, AND LIGHTING. J. B. Rathbun	8	0
BAUDÔT PRINTING TELEGRAPH SYSTEM. H. W. Pendry	6	0
BLASTING WITH HIGH EXPLOSIVES. W. G. Boulton	5	0
BLUE PRINTING AND MODERN PLAN COPYING. B. J. Hall	6	0
BREWING AND MALTING. J. Ross Mackenzie	8	6
CABINET MAKING, ART AND CRAFT OF. D. Denning	7	6
CALCULUS FOR ENGINEERING STUDENTS. J. Stoney	3	6
CARPENTRY AND JOINERY. B. F. and H. P. Fletcher	10	6
CERAMIC INDUSTRIES POCKET BOOK. A. B. Searle	8	6
CHEMICAL ENGINEERING, INTRODUCTION TO. A. F. Allen	10	6
CHEMISTRY, A FIRST BOOK OF. A. Coulthard	4	6
COLLIERY ELECTRICAL ENGINEERING. G. M. Harvey	15	0
COLOUR IN WOVEN DESIGN: A TREATISE ON TEXTILE COLOURING. R. Beaumont	21	0
COMPRESSED AIR POWER. A. W. and Z. W. Daw	21	0
CONTINUOUS-CURRENT DYNAMO DESIGN, ELEMENTARY PRINCIPLES OF. H. M. Hobart	10	6
CONTINUOUS CURRENT MOTORS AND CONTROL APPARATUS. W. Perren Maycock	7	6
COSTING ORGANIZATION FOR ENGINEERS. E. W. Workman	3	6
DETAIL DESIGN OF MARINE SCREW PROPELLERS. D. H. Jackson	6	0
DIRECT CURRENT DYNAMO AND MOTOR FAULTS. R. M. Archer	7	6

	<i>s. d.</i>
DIRECT CURRENT ELECTRICAL ENGINEERING. J. R. Barr . . . . .	15 0
DIRECT CURRENT ELECTRICAL ENGINEERING, THE ELEMENTS OF. H. F. Trewman and G. E. Condiffe . . . . .	7 6
DRAWING AND DESIGNING. C. G. Leland . . . . .	3 6
DRAWING, MANUAL INSTRUCTION. S. Barter . . . . .	4 0
DRESS, BLOUSE, AND COSTUME CLOTHS, DESIGN AND FABRIC MANUFACTURE OF. R. Beaumont . . . . .	42 0
DYNAMO, HOW TO MANAGE THE. A. R. Bottone . . . . .	2 0
DYNAMO: ITS THEORY, DESIGN, AND MANUFACTURE, THE. C. C. Hawkins. Vol. I . . . . .	21 0
Vol. II . . . . .	15 0
ELECTRIC ARC AND OXY-ACETYLENE WELDING. E. A. Atkins . . . . .	7 6
ELECTRIC BELLS. S. R. Bottone . . . . .	3 6
ELECTRIC CIRCUIT THEORY AND CALCULATIONS. W. Perren Maycock . . . . .	10 6
ELECTRIC GUIDES, HAWKINS'. 10 volumes, each . . . . .	5 0
ELECTRIC LIGHTING AND POWER DISTRIBUTION. Vol. I. W. Perren Maycock . . . . .	10 6
Vol. II . . . . .	10 6
ELECTRIC LIGHTING IN THE HOME. L. Gaster . . . . .	6
ELECTRIC LIGHTING IN FACTORIES. L. Gaster and J. S. Dow . . . . .	6
ELECTRIC LIGHT FITTING: A TREATISE ON WIRING FOR LIGHTING, HEATING, &c. S. C. Batstone . . . . .	6 0
ELECTRIC LIGHT FITTING, PRACTICAL. F. C. Allsop . . . . .	7 6
ELECTRIC MINING MACHINERY. S. F. Walker . . . . .	15 0
ELECTRIC MOTORS AND CONTROL SYSTEMS. A. T. Dover . . . . .	15 0
ELECTRIC MOTORS—DIRECT CURRENT. H. M. Hobart . . . . .	15 0
ELECTRIC MOTORS—POLYPHASE. H. M. Hobart . . . . .	15 0
ELECTRIC MOTORS, A SMALL BOOK ON. C. C. AND A. C. W. Perren Maycock . . . . .	6 0
ELECTRIC TRACTION. A. T. Dover . . . . .	21 0
ELECTRIC WIRING, FITTINGS, SWITCHES, AND LAMPS. W. Perren Maycock . . . . .	10 6
ELECTRIC WIRING DIAGRAMS. W. Perren Maycock . . . . .	5 0
ELECTRIC WIRING TABLES. W. Perren Maycock . . . . .	3 6

	<i>s. d.</i>
ELECTRICAL ENGINEERS' POCKET BOOK. Whit- taker's . . . . .	10 6
ELECTRICAL INSTRUMENT MAKING FOR AMATEURS. S. R. Bottone . . . . .	6 0
ELECTRICAL INSTRUMENTS IN THEORY AND PRAC- TICE. Murdoch and Oschwald . . . . .	12 6
ELECTRICAL MACHINES, PRACTICAL TESTING OF. L. Oulton and N. J. Wilson . . . . .	6 0
ELECTRICAL TRANSMISSION OF PHOTOGRAPHS. M. J. Martin . . . . .	6 0
ELECTRICITY. R. E. Neale . . . . .	3 0
ELECTRICITY AND MAGNETISM, FIRST BOOK OF. W. Perren Maycock . . . . .	6 0
ELECTRO MOTORS: HOW MADE AND HOW USED. S. R. Bottone . . . . .	4 6
ELECTRO-PLATERS' HANDBOOK. G. E. Bonney . . . . .	5 0
ELECTRO-TECHNICS, ELEMENTS OF. A. P. Young . . . . .	7 6
ENGINEER DRAUGHTSMEN'S WORK: HINTS TO BE- GINNERS IN DRAWING OFFICES . . . . .	2 6
ENGINEERING SCIENCE, PRIMER OF. E. S. Andrews. Part 1, 2s. 6d.; Part 2, 2s.; Complete . . . . .	3 6
ENGINEERING WORKSHOP EXERCISES. E. Pull . . . . .	3 6
ENGINEERS' AND ERECTORS' POCKET DICTIONARY: ENGLISH, GERMAN, DUTCH. W. H. Steenbeek . . . . .	2 6
ENGLISH FOR TECHNICAL STUDENTS. F. F. Potter . . . . .	2 0
FIELD MANUAL OF SURVEY METHODS AND OPERA- TIONS. A. Lovat Higgins . . . . .	21 0
FIELD WORK FOR SCHOOLS. E. H. Harrison and C. A. Hunter . . . . .	2 0
FILES AND FILING. Fremont and Taylor . . . . .	21 0
FITTING, PRINCIPLES OF. J. G. Horner . . . . .	7 6
FIVE FIGURE LOGARITHMS. W. E. Dommett . . . . .	1 6
FLAX CULTURE AND PREPARATION. F. Bradbury . . . . .	10 6
FUEL ECONOMY IN STEAM PLANTS. A Grounds . . . . .	5 0
FUEL OILS AND THEIR APPLICATIONS. H. V. Mitchell . . . . .	5 0
FUSELAGE DESIGN. A. W. Judge . . . . .	3 0
GAS, GASOLINE, AND OIL ENGINES. J. B. Rathbun . . . . .	8 0
GAS ENGINE TROUBLES AND INSTALLATIONS. J. B. Rathbun . . . . .	8 0
GAS AND OIL ENGINE OPERATION. J. Okill . . . . .	5 0

	<i>s. d.</i>
GAS, OIL, AND PETROL ENGINES: INCLUDING SUCTION GAS PLANT AND HUMPHREY PUMPS. A. Gairard . . . . .	6 0
GEOMETRY, THE ELEMENTS OF PRACTICAL PLANE. P. W. Scott . . . . .	4 0
GEOLOGY, ELEMENTARY. A. J. Jukes-Browne . . . . .	3 0
GRAPHIC STATICS, ELEMENTARY. J. T. Wight . . . . .	5 0
HANDRAILING FOR GEOMETRICAL STAIRCASES. W. A. Scott . . . . .	2 6
HIGH HEAVENS, IN THE. Sir R. Ball . . . . .	5 0
HIGHWAY ENGINEER'S YEAR BOOK. H. G. Whyatt. . . . .	6 0
HOSIERY MANUFACTURE. W. Davis . . . . .	7 6
HYDRAULICS. E. H. LEWITT . . . . .	8 6
ILLUMINANTS AND ILLUMINATING ENGINEERING, MODERN. Dow and Gaster . . . . .	25 0
INDICATOR HANDBOOK. C. N. Pickworth . . . . .	7 6
INDUCTION COILS. G. E. Bonney . . . . .	6 0
INDUCTION COIL, THEORY OF THE. E. Taylor-Jones . . . . .	12 6
INSULATION OF ELECTRIC MACHINES. H. W. Turner and H. M. Hobart . . . . .	21 0
IONIC VALVE, GUIDE TO STUDY OF THE. W. D. Owen . . . . .	2 6
IRONFOUNDING, PRACTICAL. J. G. Horner . . . . .	10 0
IRON, STEEL AND METAL TRADES, TABLES FOR THE. J. Steel . . . . .	3 6
KINEMATOGRAPHY (PROJECTION), GUIDE TO. C. N. Bennett . . . . .	10 6
LACQUER WORK. G. Koizumi . . . . .	15 0
LEATHER WORK. C. G. Leland . . . . .	5 0
LEKTRIK LIGHTING CONNECTIONS. W. Perren Maycock . . . . .	1 0
LENS WORK FOR AMATEURS. H. Orford . . . . .	3 6
LIGHTNING CONDUCTORS AND LIGHTNING GUARDS. Sir O. Lodge . . . . .	15 0
LOGARITHMS FOR BEGINNERS. C. N. Pickworth . . . . .	1 6
MACHINE DRAWING, PREPARATORY COURSE TO. P. W. Scott . . . . .	2 0
MAGNETISM AND ELECTRICITY, AN INTRODUCTORY & COURSE OF PRACTICAL. J. R. Ashworth . . . . .	3 0

	<i>s. d.</i>
MAGNETO AND ELECTRIC IGNITION. W. Hibbert . . . . .	3 6
MANURING LAND, TABLES FOR MEASURING AND. J. Cullyer . . . . .	3 0
MARINE ENGINEERS, PRACTICAL ADVICE FOR. C. W. Roberts . . . . .	5 0
MARINE SCREW PROPELLERS. DETAIL DESIGN OF. D. H. Jackson . . . . .	6 0
MATHEMATICAL TABLES. W. E. Dommatt . . . . .	4 6
MATHEMATICS, MINING (PRELIMINARY). G. W. Stringfellow. With Answers . . . . .	2 0
MECHANICAL ENGINEERING DETAIL TABLES. J. P. Ross . . . . .	7 6
MECHANICAL ENGINEERS' POCKET BOOK. Whittaker's . . . . .	12 6
MECHANICAL STOKING. D. Brownlie . . . . .	5 0
MECHANICAL TABLES . . . . .	2 0
MECHANICS' AND DRAUGHTSMEN'S POCKET BOOK. W. E. Dommatt . . . . .	2 6
METAL TURNING. J. G. Horner . . . . .	4 0
METAL WORK, PRACTICAL SHEET AND PLATE. E. A. Atkins . . . . .	7 6
METAL WORK—REPOUSSÉ. C. G. Leland . . . . .	5 0
METAL WORK, TEACHER'S HANDBOOK. J. S. Miller . . . . .	4 0
METRIC AND BRITISH SYSTEMS OF WEIGHTS AND MEASURES. F. M. Perkin . . . . .	3 6
METRIC CONVERSION TABLES. W. E. Dommatt . . . . .	2 6
MILLING, MODERN. E. Pull . . . . .	9 0
MINERALOGY. F. H. Hatch . . . . .	6 0
MINING, MODERN PRACTICE OF COAL. Kerr and Burns. Part 1, 5/-; Parts 2, 3 and 4, each . . . . .	6 0
MINING SCIENCE, JUNIOR COURSE IN. H. G. Bishop . . . . .	2 6
MOTION PICTURE OPERATION, STAGE ELECTRICS, ETC. H. C. Horstmann and V. H. Tousley . . . . .	7 6
MOTOR TRUCK AND AUTOMOBILE MOTORS AND MECHANISM. T. H. Russell . . . . .	8 0
MOTOR BOATS, HYDROPLANES AND HYDROAEROPLANES. T. H. Russell . . . . .	8 0
MUSIC ENGRAVING AND PRINTING. W. Gamble . . . . .	21 0
NAVAL DICTIONARY, ITALIAN-ENGLISH AND ENGLISH-ITALIAN. W. T. Davis . . . . .	10 6

	<i>s. d.</i>
OPTICS OF PHOTOGRAPHY AND PHOTOGRAPHIC LENSES. J. T. Taylor . . . . .	4 0
PATENTS FOR INVENTIONS. J. E. Walker and R. B. Foster . . . . .	21 0
PATTERN-MAKING, PRINCIPLES OF. J. G. Horner	4 0
PIPES AND TUBES: THEIR CONSTRUCTION AND JOINTING. P. R. Björling . . . . .	6 6
PLAN COPYING IN BLACK LINES FOR HOT CLIMATES. B. J. Hall . . . . .	2 6
PLYWOOD AND GLUE, MANUFACTURE AND USE OF, THE. B. C. Boulton . . . . .	7 6
POLYPHASE CURRENTS. A. Still . . . . .	7 6
POWER STATION EFFICIENCY CONTROL. J. Bruce.	12 6
POWER WIRING DIAGRAMS. A. T. Dover . . . . .	7 6
PRINTING. H. A. Maddox . . . . .	5 0
QUANTITIES AND QUANTITY TAKING. W. E. Davis	6 0
RADIO COMMUNICATION, MODERN. J. H. Reyner	5 0
RADIO YEAR BOOK . . . . .	1 6
RAILWAY TECHNICAL VOCABULARY. L. Serrailier	7 6
REFRACTORIES FOR FURNACES, CRUCIBLES, ETC. A. B. Searle . . . . .	5 0
REINFORCED CONCRETE. W. N. Twelvetrees .	21 0
REINFORCED CONCRETE BEAMS AND COLUMNS, PRACTICAL DESIGN OF. W. N. Twelvetrees .	7 6
REINFORCED CONCRETE MEMBERS, SIMPLIFIED METHODS OF CALCULATING. W. N. Twelvetrees	5 0
REINFORCED CONCRETE, DETAIL DESIGN IN. E. S. Andrews . . . . .	6 0
ROSES AND ROSE GROWING. R. G. Kingsley .	7 6
RUSSIAN WEIGHTS AND MEASURES, TABLES OF. Redvers Elder . . . . .	2 6
SHOT-GUNS. H. B. C. Pollard . . . . .	6 0
SLIDE RULE. A. L. Higgins . . . . .	6
SLIDE RULE. C. N. Pickworth . . . . .	3 6
SOIL, SCIENCE OF THE. C. Warrell . . . . .	3 6
STEAM TURBINE THEORY AND PRACTICE. W. J. Kearton . . . . .	15 0
STEAM TURBO-ALTERNATOR, THE. L. C. Grant .	15 0
STEELS, SPECIAL. T. H. Burnham . . . . .	5 0
STEEL WORKS ANALYSIS. J. O. Arnold and F. Ibbotson . . . . .	12 6

	<i>s.</i>	<i>d.</i>
STORAGE BATTERY PRACTICE. R. Rankin . . .	7	6
SURVEYING AND SURVEYING INSTRUMENTS. G. A. T. Middleton . . . . .	6	0
SURVEYING, TUTORIAL LAND AND MINE. T. Bryson	10	6
TELEGRAPHY: AN EXPOSITION OF THE TELEGRAPH SYSTEM OF THE BRITISH POST OFFICE. T. E. Herbert . . . . .	18	0
TELEGRAPHY, ELEMENTARY. H. W. Pendry . . .	7	6
TELEPHONE HANDBOOK AND GUIDE TO THE TELEPHONIC EXCHANGE, PRACTICAL. J. Poole	15	0
TELEPHONY. T. E. Herbert . . . . .	18	0
TEXTILE CALCULATIONS. G. H. Whitwam . . .	25	0
TRANSFORMER PRACTICE, THE ESSENTIALS OF. E. G. Reed . . . . .	12	6
TRIGONOMETRY FOR ENGINEERS, PRIMER OF. W. G. Dunkley . . . . .	5	0
TURRET LATHE TOOLS, HOW TO LAY OUT . . .	6	0
UNION TEXTILE FABRICATION. R. Beaumont . .	21	0
VENTILATION, PUMPING, AND HAULAGE, THE MATHEMATICS OF. F. Birks . . . . .	5	0
VOLUMETRIC ANALYSIS. J. B. Coppock . . .	3	6
WATER MAINS, THE LAY-OUT OF SMALL. H. H. Hellins . . . . .	7	6
WATERWORKS FOR URBAN AND RURAL DISTRICTS. H. C. Adams . . . . .	15	0
WEAVING FOR BEGINNERS. L. Hooper . . . . .	5	0
WEAVING WITH SMALL APPLIANCES—THE WEAVING BOARD. L. Hooper . . . . .	7	6
WEAVING WITH SMALL APPLIANCES—TABLET WEAVING. L. Hooper . . . . .	7	6
WIRELESS FOR THE HOME. N. P. Hinton . . .	1	6
WIRELESS POCKET BOOK, MARINE. W. H. Marchant	6	0
WIRELESS TELEGRAPHY AND TELEPHONY, AN INTRODUCTION TO. J. A. Fleming . . . . .	3	6
WIRELESS TELEGRAPHY. W. H. Marchant . . .	7	6
WOOD-BLOCK PRINTING. F. Morley Fletcher . .	8	6
WOODCARVING. C. G. Leland . . . . .	7	6
WOODWORK, MANUAL INSTRUCTION. S. Barter . .	7	6
WOOL SUBSTITUTES. R. Beaumont . . . . .	10	6

*Catalogue of Scientific and Technical Books post free.*

LONDON: SIR ISAAC PITMAN & SONS, LTD.  
PARKER STREET, KINGSWAY, W.C.2





**UNIVERSITY OF CALIFORNIA LIBRARY  
Los Angeles**

**This book is DUE on the last date stamped below.**

Form L9-40m-7,'56 (C790s4) 444

**THE LIBRARY  
UNIVERSITY OF CALIFORNIA  
LOS ANGELES**

TP North -  
355 Oil power  
N81o

UC SOUTHERN REGIONAL LIBRARY FACILITY



A 001 189 454 0

TP  
355  
N81o

