

THE ONTARIO HIGH SCHOOL PHYSICS



AUTHORIZED BY
THE MINISTER OF EDUCATION FOR ONTARIO

PRICE 90 CENTS

TORONTO
THE COPP CLARK COMPANY LIMITED



Digitized by the Internet Archive
in 2009 with funding from
Ontario Council of University Libraries

127 E. D. 1517

THE ONTARIO HIGH SCHOOL PHYSICS

BY

F. W. MERCHANT, M.A., D.PAED.,

*Director of Technical and Industrial Education
for Ontario*

AND

C. A. CHANT, M.A., PH.D.,

*Associate Professor of Astrophysics,
University of Toronto*

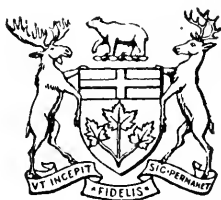

Authorized by the Minister of Education for Ontario
for use in the Middle School

TORONTO
THE COPP, CLARK COMPANY, LIMITED

Copyright, Canada 1911, by THE COPP, CLARK COMPANY, LIMITED,
Toronto, Ontario.

FIRST EDITION, 1911.

REPRINTED, 1911, 1912, 1912, 1913, 1914, 1914, 1915, 1917.

P R E F A C E

In the printing of this book two sizes of type have been mainly used. The portion printed in large type (§ 1 for example) is intended to cover the course in Physics at present prescribed for the classes of the Middle School. The sections in smaller type (§ 24 for example) have been included in order to render the treatment of the subject more complete.

In dealing with the various branches of the subject an attempt has been made to illustrate its principles and laws by reference to numerous applications in ordinary life. Other illustrations are taken from the chief applications of Physics to industry and commerce, especially those to be seen in our own country.

Practical questions and problems are proposed in connection with important topics in the text. The materials for these exercises have been selected with the purpose, not only of illustrating and applying the principles discussed, but also of stimulating the interest of the student in the physical phenomena with which he is familiar.

Attention is directed to the diagrams and other drawings, of which there is an exceptionally large number. These have all been prepared especially for this work, and great pains have been taken to have them clear and easily understood.

The portraits of some of the great scientific investigators and the historical references which have been woven into almost every chapter, will, it is hoped, awaken a real human interest in the subject.

Throughout the work appear concise tables of physical constants, which have been taken from the *Smithsonian Physical Tables*, published by the Smithsonian Institution, Washington, D.C.

In the preparation of the book the authors have received courteous assistance from many firms and individuals regarding certain industrial applications of Physics. They are also indebted to many friends engaged in the practical teaching of the subject in secondary schools and colleges; but they are especially indebted to Dr. A. L. Clark, Professor of Physics at Queen's University, Kingston, and to Dr. W. E. McElfresh, Professor of Physics at Williams College, Williamstown, Mass., who carefully read the proof-sheets and offered many valuable suggestions.

A *Laboratory Manual* has been prepared to accompany this book. It contains a large number of exercises, with full instructions for the student's guidance.

TORONTO, June, 1911.

CONTENTS

CHAPTER		PAGE
PART I—INTRODUCTION		
I.—	Measurement	1
PART II—MECHANICS OF SOLIDS		
II.—	Displacement, Velocity, Acceleration	17
III.—	Inertia, Momentum, Force	33
IV.—	Moment of a Force ; Composition of Parallel Forces ; Equilibrium of Forces	44
V.—	Gravitation	50
VI.—	Work and Energy	54
VII.—	Centre of Gravity	60
VIII.—	Friction	64
IX.—	Machines	67
PART III—MECHANICS OF FLUIDS		
X.—	Pressure of Liquids	82
XI.—	Buoyancy of Fluids	92
XII.—	Determination of Density	96
XIII.—	Pressure in Gases	101
XIV.—	Applications of the Laws of Gases	119
PART IV—SOME PROPERTIES OF MATTER		
XV.—	The Molecular Theory of Matter	131
XVI.—	Molecular Forces in Solids and Liquids	142
XVII.—	Phenomena of Surface Tension and Capillarity	150

PART V—WAVE MOTION AND SOUND

CHAPTER	PAGE
XXVIII.—Wave Motion	157
XIX.—Production, Propagation, Velocity of Sound . . .	168
XX.—Pitch, Musical Scales	179
XXI.—Vibrations of Strings, Rods, Plates and Air Columns	187
XXII.—Quality, Vibrating Flames, Beats	200
XXIII.—Musical Instruments—The Phonograph	209

PART VI—HEAT

XXIV.—Nature and Source of Heat	214
XXV.—Expansion through Heat	217
XXVI.—Temperature	222
XXVII.—Relation between Volume and Temperature . . .	229
XXVIII.—Measurement of Heat	238
XXIX.—Change of State	243
XXX.—Heat and Mechanical Motion	267
XXXI.—Transference of Heat	274

PART VII—LIGHT

XXXII.—The Nature of Light ; its Motion in Straight Lines	287
XXXIII.—Photometry	294
XXXIV.—The Velocity of Light	300
XXXV.—Reflection of Light : Plane Mirrors	302
XXXVI.—Reflection from Curved Mirrors	309
XXXVII.—Refraction	319
XXXVIII.—Lenses	330
XXXIX.—Dispersion, Colour, the Spectrum, Spectrum Analysis	339
XL.—Optical Instruments	356

PART VIII—ELECTRICITY AND MAGNETISM

CHAPTER	PAGE
XLI.—Magnetism	367
XLII.—Electricity at Rest	380
XLIII.—The Electric Current	396
XLIV.—Chemical Effects of the Electric Current	408
XLV.—Magnetic Relations of the Current	419
XLVI.—Induced Currents	435
XLVII.—Applications of Induced Currents	442
XLVIII.—Heating and Lighting Effects of the Electric Current	457
XLIX.—Electrical Measurements	462
L.—Other Forms of Radiant Energy	479
Answers to Numerical Problems	492
Index	495

TABLE OF EQUIVALENTS OF UNITS

LENGTH

1 in. = 2.54 cm.	1 cm. = 0.3937 in.
1 ft. = 30.48 cm.	1 m. = 39.37 in. = 1.094 yd.
1 yd. = 91.44 cm.	1 km. = 0.6214 mi.
1 mi. = 1.609 km.	1 km. = 1000 m., 1 m. = 100 cm., 1 cm. = 10 mm.

SURFACE

1 sq. in. = 6.4514 sq. cm.	1 sq. cm. = 0.1550 sq. in.
1 sq. ft. = 929.01 sq. cm.	1 sq. m. = 10.764 sq. ft.
1 sq. yd. = 8361.3 sq. cm. = 0.83613 sq. m.	1 sq. m. = 1.196 sq. yd.

VOLUME

1 c. in. = 16.387 c.c.	1 c.c. = 0.061 c. in.
1 c. ft. = 28317 c.c.	1 l. = 1000 c.c. = 61.024 c. in.
1 c. yd. = 0.7645 cu. m.	1 cu. m. = 1.308 c. yd.
1 Imperial gallon = 10 lb. water at 62° F. = 277.274 c. in. = 4.546 l.	
1 Imperial quart = 1.136 l.	
1 U.S. gallon = 231 c. in. = 3.784 l.	
1 l. = 1.7598 Imperial pints.	

MASS

1 lb. av. (7000 gr.) = 453.59 g.	1 kg. = 2.205 lb. av.
1 oz. av. = 28.3495 g.	1 g. = 15.432 gr.
1 gr. = 0.0648 g.	

ABBREVIATIONS

in. = inch ; ft. = foot ; yd. = yard ; mi. = mile ; sq. = square ;
 c. or cu. = cubic ; m. = metre ; mm. = millimetre ; cm. = centimetre ;
 km. = kilometre ; c. cm. or c.c. = cubic centimetre ; l. = litre ; lb. av. =
 pound avoirdupois ; gr. = grain ; g. = gram ; kg. = kilogram.

PART I—INTRODUCTION

CHAPTER I

MEASUREMENT

1. Physical Quantities. The various operations of nature are continually before our eyes, and thus by the time that we definitely enter upon the study of physics, we have gathered a store of observations and experiences.

We all admire the beauty of a water-fall, but we recognize that there is more than beauty in it when we see it made to turn our mills. In recent years the world's great water-powers have been used to generate electricity, which, after being transmitted over considerable distances, supplies motive-power for our great factories or our street railways. The sun continually sends forth immense quantities of heat and light, conveying to us warmth and cheer, and preserving life itself. We see the giant ship or the railway train, driven by the power of steam, transporting the commerce of the nations. And in the near future we shall probably see multitudes of aeroplanes circling about in the air and carrying passengers from place to place.

When asked to describe how these various physical effects are produced we usually reply in vague and general terms. The study of physics is intended to give definiteness to our descriptions, and to enable us clearly to state the relations between successive physical events.

In order to do this we must understand the numerous operations met with in mechanics, heat, electricity, and other

branches of physics; and our knowledge of these matters can hardly be considered satisfactory unless we are able actually to measure the various physical quantities involved. We must not be content with saying simply that a certain substance was present, or that a result of a certain kind was obtained; but we should be able to state how much of that substance was present, or the precise relation of the result obtained to the causes producing it.

2. Measuring a Quantity. In measuring a quantity we determine how many times a magnitude of the same kind, which we call a *unit*, is contained in the quantity to be measured.

Thus we speak of a length being 5 feet, the unit chosen being a *foot*, and 5 expressing the number of times the unit is contained in the given length.

3. Fundamental Units. There will be as many kinds of units as there are kinds of quantities to be measured, and the size of the units may be just what we choose. But there are three units which we speak of as *fundamental*, namely the units of *length*, *mass* and *time*. These units are fundamental in the sense that each is independent of the others and cannot be derived from them; also we shall find that the measurement of any quantity,—such as the power of a steam engine, the speed of a rifle-bullet or the strength of an electric current,—can ultimately be reduced to measurement of length, mass and time. Hence these units are properly considered fundamental.

4. Standards of Length,—the Yard. There are two *standards* of length in use in English-speaking countries, namely, the *yard* and the *metre*.

The yard is said to have represented, originally, the length of the arm of King Henry I., but such a definition is not by any means accurate enough for present-day requirements. It

is now defined as the distance between the centres of two transverse lines ruled on two gold plugs in a bronze bar, which is preserved in London, England, in the Standards Office of the Board of Trade of Great Britain.

The bronze bar is 38 inches long and has a cross-section one inch square (Fig. 1). At a, a , wells are sunk to the mid-depth of the bar, and at the bottom of each well is the gold plug or pin, about $\frac{1}{10}$ inch in diameter, on which the line defining the yard is engraved.

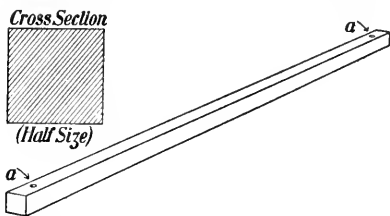

FIG. 1.—Bronze yard, 38 in. long, 1 in. sq. in section. a, a are small wells in bar, sunk to mid-depth.

The other units of length in ordinary use, such as the inch, the foot, the rod, the mile, are derived from the yard, though the relations between them are not always simple.

5. The Metre. The metre came into existence through an effort made in France, at the end of the 18th century, to replace by one standard the many and confusing standards of length prevailing throughout the country. It was decided that the new standard should be called a metre, and that it should be one ten-millionth of the distance from the pole to the equator, measured through Paris. The system was provisionally established by law in 1793, and the standard bar representing the length was completed in 1799. This bar is of platinum, just a metre from end to end, 25 millimetres (about 1 inch) wide and 4 millimetres (about $\frac{1}{8}$ inch) thick.

As time passed, great difficulty was experienced in making exact copies of this platinum rod, and as the demand for such continually increased, it was decided to construct a new standard bar.

Following the great "World's Fairs" held in London in 1851 and in Paris in 1867, proposals were made for international

coöperation in the production of the new standards; and after several preliminary conferences, in 1875 there was convened in Paris an International Committee of delegates officially appointed by various national governments. By this Committee the International Bureau of Weights and Measures was established at Sèvres, near Paris, and the different nations contribute annually towards its maintenance. By this bureau 31 standard metres and 40 standard kilograms, known as *prototype* metres and kilograms, have been constructed.

The new metre bars are made of a hard and durable alloy composed of platinum 90 per cent. and iridium 10 per cent., and have the form shown in Fig. 2. The section illustrated here was chosen on account of its great rigidity, and also in order that the cross-lines which define the length of the metre might be placed on the face which is just mid-way between the upper and lower faces of the bar. The bars are 102 centimetres in length over all, and 20 millimetres square in section. Thus the lines which define the metre are one centimetre from each end of the bar.

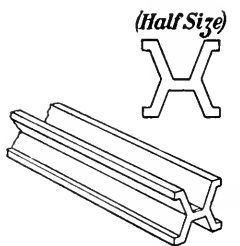

FIG. 2.—View of end and cross-section of the standard 'prototype' metre bars. The line defining the end of the metre is a short mark on the surface midway between the top and bottom of the bar.

All the bars were completed in 1889. They were made as nearly as possible equal in length to the original platinum one of 1799, but of course minute differences existed between them—perhaps one part in one hundred million. So the one which appeared to agree most perfectly with the old standard was taken as the new International Prototype Standard. The new kilogram (see § 11) was also chosen from all that had been made. These were adopted as the new international standards on Sept. 26, 1889, by the International Committee. They are kept in a special vault in the International Bureau

secured by three locks, the keys of which are kept by three different high officials. The vault is opened not oftener than once a year, at which time all three officials must be present.

6. National Standards. The metre rod kept in the vault at Sèvres is the standard for the world. Each nation contributing to the International Bureau is entitled to a prototype metre and kilogram. Great Britain and the United States have their copies. In the former country all the standards are kept in the Standards Office in London; in the latter, they are preserved in the Bureau of Standards in Washington.

In the United States the metre is taken as the primary standard of length, and by law

$$1 \text{ yard} = \frac{3600}{3937} \text{ of a metre.}$$

The standard yard and the standard metre at present in use in Canada are both of bronze, of the form illustrated in Fig. 1. They were obtained from England in 1874. Quite recently, however, Canada has been admitted to the International Committee as an autonomous nation, and so is entitled to receive one of the prototype metres and one of the prototype kilograms constructed by the International Bureau. No doubt these will soon be secured. The Canadian standards are kept in the Standards Office of the Department of Inland Revenue, Ottawa.

7. The Metre Independent of the Size of the Earth. Great care was taken to have the original metre exactly one ten-millionth of the distance from the pole to the equator; but when once the standard had been constructed it became the fixed standard unit, no further reference being made to the dimensions of the earth.

Indeed, later measurements and calculations have shown that there are more than ten million metres in the earth-quadrant, and hence the metre is a little shorter than it

was intended to be. The difference, however, is very small about $\frac{1}{12}$ mm., which is perhaps a hair's breadth.

8. Sub-divisions of the Metre. The metre is divided decimally, thus:—

$$\begin{aligned} \frac{1}{10} \text{ metre} &= 1 \text{ decimetre (dm.)} \\ \frac{1}{10} \text{ dm.} &= 1 \text{ centimetre (cm.)} \\ \frac{1}{10} \text{ cm.} &= 1 \text{ millimetre (mm.)} \\ 1 \text{ m.} &= 10 \text{ dm.} = 100 \text{ cm.} = 1000 \text{ mm.} \end{aligned}$$

For greater lengths, multiples of ten are used, thus:—

$$\begin{aligned} 10 \text{ metres} &= 1 \text{ decametre.} \\ 10 \text{ decametres} &= 1 \text{ hectometre.} \\ 10 \text{ hectometres} &= 1 \text{ kilometre (km.)} \\ 1 \text{ km.} &= 1000 \text{ m.} \end{aligned}$$

The *decametre* and the *hectometre* are not often used.

9. Relation of Metres to Yards. In Great Britain the relation between the metre and the inch is officially stated to be

$$1 \text{ metre} = 39.370113 \text{ inches ;}$$

in the United States, by law,

$$1 \text{ metre} = 39.37 \text{ inches.}$$

The difference between these two statements of length of the metre is only $\frac{1}{1000000}$ inch, and the British and United States yards may be considered identical.

The following relations hold:—

$$\begin{aligned} 1 \text{ cm.} &= 0.3937 \text{ in.} & 1 \text{ in.} &= 2.54 \text{ cm.} \\ 1 \text{ m.} &= 39.37 \text{ in.} = 1.094 \text{ yd.} & 1 \text{ ft.} &= 30.48 \text{ cm.} \\ 1 \text{ km.} &= 0.6214 \text{ mi.} & 1 \text{ mi.} &= 1.609 \text{ km.} \end{aligned}$$

$$\begin{aligned} \text{Approximately } 10 \text{ cm.} &= 4 \text{ in.} \\ 30 \text{ cm.} &= 1 \text{ ft.} \\ 8 \text{ km.} &= 5 \text{ mi.} \end{aligned}$$

In Fig. 3 is shown a comparison of centimetres and inches.

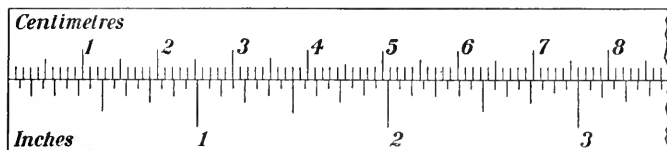

FIG. 3.—Comparison of inches and centimetres.

10. Derived Units. The ordinary units of surface and of volume are at once deduced from the lineal units. The imperial gallon is defined as the volume of 10 pounds of water at 62° F., or is equal to 277.274 cu. in. (The U.S. or Winchester gallon = 231 cu. in.). The litre contains 1,000 c. cm.

The following relations hold :—

1 sq. yd. = 0.836 sq. m.	1 c. dem. = 61.024 c. in.
1 sq. m. = 10.764 sq. ft.	1 gal. = 4.546 l.
1 cu. in. = 16.387 c.c.	1 l. = 1.76 qt.

PROBLEMS

(For table of values see opposite page 1)

- How many millimetres in $2\frac{1}{2}$ kilometres ?
- Change 186,330 miles to kilometres.
- How many square centimetres in a rectangle 54×60 metres ?
- Change 760 mm. into inches.
- Reduce 1 cubic metre to litres and to cubic centimetres.
- Lake Superior is 602 feet above sea level. Express this in metres.
- Dredging is done at 50 cents per cubic yard. Find the cost per cubic metre.
- Air weighs 1.293 grams per litre. Find the weight of the air in a room $20 \times 25 \times 15$ metres in dimensions.
- Which is cheaper, milk at 7 cents per litre or 8 cents per quart ?
- Express, correct to a hundredth of a millimetre, the difference between 12 inches and 30 centimetres.

11. Standards of Mass. By the *mass* of a body is meant the *quantity of matter* in it. Matter may change its form,

but it can never be destroyed. A lump of matter may be transported to any place in the universe, but its mass will remain the same.

There are two units of mass in ordinary use, namely, the *pound* and the *kilogram*.

The standard pound avoirdupois is a certain piece of platinum preserved in the Standards Office in London, England. Its form is illustrated in Fig. 4. The grain is $\frac{1}{7000}$ of the pound, and the ounce is $\frac{1}{16}$ of the pound or 437.5 grains.



FIG. 4.—Imperial Standard Pound Avoirdupois. Made of platinum. Height 1.35 inches; diameter 1.15 inches. "P.S." stands for *parliamentary standard*.

The kilogram is the mass of a certain lump of platinum carefully preserved in Paris, and called the "Kilogramme des Archives." It was constructed by Borda (who also made the original platinum metre), and was intended to represent the mass of 1000 cubic centimetres (1 litre) of water when at its maximum density (at 4° C.).

Although the objection which had been raised against the platinum metre (namely, difficulty in reproducing it), did not hold in the case of the platinum kilogram; still the platinum-iridium alloy is harder and more durable than pure platinum, and so the International Committee decided to make new standards out of this alloy. As already stated (in § 5), the International Bureau constructed 40 standard kilograms. These were all made as nearly as possible equal to the original platinum kilogram, and indeed as they do not differ amongst themselves by more than about one part in one hundred million, they may be considered identical.

One of these was adopted as the new International Prototype kilogram, and is preserved along with the International

metre at Sèvres. The others, as far as required, have been distributed to various nations, and are known as National Prototype kilograms.

These new standards are plain cylinders, almost exactly $1\frac{1}{2}$ inches in diameter, and of the same height. (Figs. 5 and 6.)

The relation of the pound to the kilogram is officially stated by the British government as follows:—

1 kilogram (kg.)	=	2.2046223 pounds avoird.
1 gram (gm.)	=	15.4323564 grains.
1 pound avoird.	=	0.45359243 kg.
1 ounce avoird.	=	28.349527 grams.

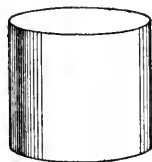

FIG. 5.—Prototype kilogram, made of an alloy of platinum and iridium. Height and diameter each 1.5 inches.

In transforming from kilograms to pounds, or the reverse, it will not be necessary to use so many decimal places as are given here. The equivalent values may be taken from the table opposite page 1.

Approximately 1 kg. = $2\frac{1}{2}$ lbs.; 1 oz. = $28\frac{1}{3}$ gm.

12. Unit of Time.

If we reckon from the time when the sun is on our meridian (noon), until it is on the meridian again, the interval is a *solar day*. But the solar days thus

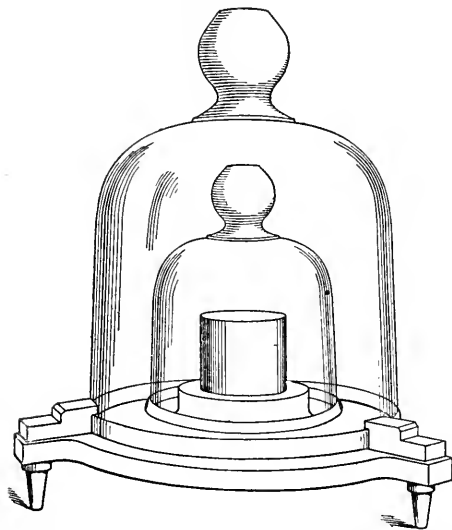

FIG. 6.—United States National Kilogram "No. 20." Kept under two glass bell-jars at Washington.

determined are not all exactly equal to each other. This, as is explained in works on astronomy, is due to two causes,

(1) the earth's orbit is an ellipse, not a circle, (2) the plane of the orbit is inclined to the plane of the earth's equator. In order to get an invariable interval we take the average of all the solar days for an entire year, and call the day thus obtained a *mean solar day*. Dividing this into 86,400 equal parts we call each a mean solar *second*. This is the quantity which is "ticked off" by our watches and clocks. It is used universally by scientific men as the fundamental unit of time.

13. The English and the C. G. S. System. In the so-called English system of units the *foot*, the *pound* and the *second* are the units of length, mass and time, respectively. In another system, which is used almost universally in purely scientific work, the units of length, mass and time are 1 *centimetre*, 1 *gram* and 1 *second*, respectively.

The former is sometimes called the F.P.S. system, the latter the C.G.S. system, the distinguishing letters being the initials of the units in the two cases.

14. Measurement of Length. A dry-goods merchant unrolls his cloth, and, placing it alongside his yard-stick, measures off the quantity ordered by the customer. Now the yard-stick is intended to be an accurate copy of the standard yard kept at the capital of the country, and this latter we know is an accurate copy of the original preserved in London, England. In order to ensure the accuracy of the merchant's yard-stick a government official periodically inspects it, comparing it with a standard yard which he carries with him.

Suppose, next, that we require to know accurately the diameter of a wire, or of a sphere, or the distance between

two marks on a photographic plate. We choose the most suitable instrument for the purpose in view. For the wire or the sphere a screw gauge would be very convenient. One of these is illustrated in Fig. 7. *A* is the end of a screw which works in a nut inside of *D*. The screw can be moved back and forth by turning the cap *C* to which it is attached, and which slips over *D*. Upon *D* is a scale, and the end of the cap *C* is divided into a number of equal parts. By turning the cap the end *A* moves forward until it reaches the stop *B*. When this is the case the graduations on *D* and *C* both read zero.

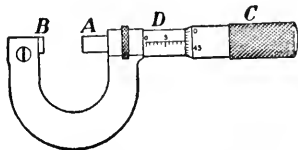

FIG. 7.—Micrometer wire gauge.

In order to measure the diameter of a wire, the end *A* is brought back until the wire just slips between *A* and *B*. Then the scales on *D* and *C* indicate the whole number of turns made by the screw and also the fraction of a turn. Hence if we know the pitch of the screw, which is usually $\frac{1}{50}$ inch, we can at once calculate the diameter of the wire.

To measure the photographic plate the most convenient instrument is a microscope which can be moved back and forth over the plate, or one in which the stage which carries the plate can be moved by screws with graduated heads, much as in the wire gauge.

There are other devices for accurate measurement of lengths, but in every case the scale, or the screw, or whatever is the essential part of the instrument, must be carefully compared with a good standard before our measurements can be of real value.

15. Measurement of Mass. In Fig. 8 is shown a balance. The pans *A* and *B* are suspended from the ends of the beam *CD*, which can turn easily about a “knife-edge” at *E*.

This is usually a sharp steel edge resting on a steel or an agate plate. The bearings at *C* and *D* are made with

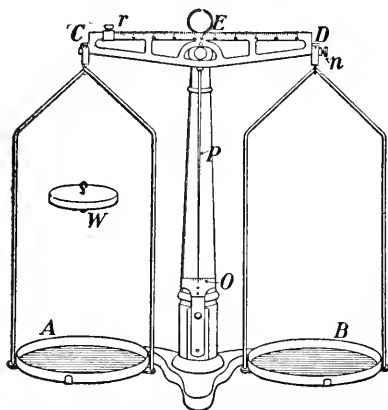

FIG. 8.—A simple and convenient balance. When in equilibrium the pointer *P* stands at zero on the scale *O*. The nut *n* is for adjusting the balance and the small weights, fractions of a gram, are obtained by sliding the rider *r* along the beam which is graduated. The weight *W*, if substituted for the pan *A*, will balance the pan *B*.

very little friction, so that the beam turns very freely. A long pointer *P* extends downwards from the middle of the beam, and its lower end moves over a scale *O*. When the pans are balanced and the beam is level the pointer is opposite zero on the scale.

Suppose a lump of matter is placed on pan *A*. At once it descends and equilibrium is destroyed. It goes downward because the earth attracts the matter.

Now put another lump on pan *B*. If the pan *B* still remains up we say the mass on *A* is heavier than that on *B*; if the pans come to the same level and the pointer stands at zero the two masses are equal.

It is the attraction of the earth upon the masses placed upon the pans which produces the motion of the balance. The attraction of the earth upon a mass is called its *weight*, and so in the balance it is the weights of the bodies which are compared. But, as is explained in Chapter V, the weight of a body is directly proportional to its mass, and so the balance allows us to compare masses.

16. Sets of Weights. We have agreed that the lump of platinum-iridium known as the International Prototype Kilogram shall be our standard of mass. (§ 11.)

In order to duplicate it we simply place it on one pan of the balance, and by careful filing we make another piece of matter which, when placed on the other pan, will just balance it.

Again, with patience and care two masses can be constructed which will be equal to each other, and which, taken together, will be equal to the original kilogram. Each will be 500 grams.

Continuing, we can produce masses of other denominations, and we may end by having a set consisting of

1,000,
500, 200, 200, 100
50, 20, 20, 10
5, 2, 2, 1
.5, .2, .2, .1 grams

and even smaller weights.

If now a mass is placed on pan *A* of the balance, by proper combination of these weights we can balance it and thus at once determine its mass.

The balances and the weights used by merchants throughout the country are periodically inspected by a government officer.

17. Density. Let us take equal volumes of lead, aluminium, wood, brass, cork. These may conveniently be cylinders about $\frac{1}{2}$ inch in diameter and $1\frac{1}{2}$ or 2 inches in length.

By simply holding them in the hand we recognize at once that these bodies have different weights and therefore different masses. With the balance and our set of weights we can accurately determine the masses.

We describe the difference between these bodies by saying that they are of different densities, and we define density thus:—

The DENSITY of a substance is the mass of unit volume of that substance.

If we use the foot and the pound as units of length and mass respectively, the density will be the number of pounds in 1 cubic foot.

In the C.G.S. system the units of mass and volume are 1 gram and 1 c.c. respectively, and of course the density will be the number of grams in 1 c.c.

But 1 litre of water has a mass of 1 kilogram,
 or 1000 c.c. “ “ “ 1000 gm.,
 or 1 c.c. “ “ “ 1 gm.

This is the system generally used in scientific work. The densities of some of the ordinary substances are given in the following table:—

TABLE OF DENSITIES

	Pounds per Cubic Foot.	Grams per Cubic Centimetre.
Water (at 4° C.).....	62.4	1.00
Iron.....	439 to 445	7.03 to 7.13
Copper.....	555	8.90
Silver.....	658	10.56
Lead.....	708	11.34
Mercury.....	848	13.60
Gold.....	1207	19.34
Platinum.....	1340	21.50
Iridium.....	1399	22.42
White Pine.....	22 to 31	0.35 to 0.50

Note also that since the density is the mass in unit volume, we have the relation,

$$\text{Mass} = \text{Volume} \times \text{Density.}$$

Thus, if the volume of a piece of cast aluminium is 150 c.c., since its density is 2.56, the

$$\begin{aligned} \text{Mass} &= 150 \times 2.56 \\ &= 384 \text{ grams.} \end{aligned}$$

18. Relation between Density and Specific Gravity. We have seen that the number expressing the density of a substance differs according to the system of units we use.

Specific gravity is defined to be the ratio which the weight of a given volume of the substance bears to the weight of an equal volume of water.

As this is a simple *ratio*, it is expressed by a simple number, and is quite independent of any system of units.

First, however, suppose we have a cubic foot of a substance. Let it weigh W lbs.

Let the weight of 1 cubic foot of water be w lbs.

$$\begin{aligned} \text{Then specific gravity} &= \frac{W}{w}, \\ &= \frac{\text{density of substance}}{\text{density of water}}. \end{aligned}$$

We see at once that this *ratio* is the same no matter what volume we use.

Again, since in the C.G.S. system the density of water is 1, it follows that in this system the number expressing the specific gravity is the same as that expressing the density.

For example, suppose we have 50 c.c. of cast iron. Then, using the balance, we find

$$\begin{aligned} \text{Weight of 50 c.c. of iron} &= 361 \text{ gm.} \\ \text{But " " 50 " " water} &= 50 \text{ " "} \end{aligned}$$

Therefore the specific gravity $= \frac{361}{50} = 7.22$, which is simply the weight in grams of 1 c.c. of iron, or the density in the C.G.S. system.

PROBLEMS

1. Find the mass of 140 c.c. of silver if its density is 10.5 gm. per c.c.
2. The specific gravity of sulphuric acid is 1.85. How many c.c. must one take to weigh 100 gm. ?
3. A rolled aluminium cylinder is 20 cm. long, 35 mm. in diameter, and its density is 2.7. Find the weight of the cylinder.
4. The density of platinum is 21.5, of iridium is 22.4. Find the density of an alloy containing 9 parts of platinum to 1 part of iridium. Find the volume of 1 kg. of the alloy.

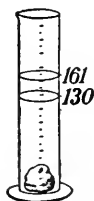

FIG. 9.

5. A piece of granite weighs 83.7 gm. On dropping it into the water in a graduated vessel, the water rises from 130 c.c. to 161 c.c. (Fig. 9). Find the density of the granite.
6. A tank 50 cm. long, 20 cm. wide and 15 cm. deep is filled with alcohol of density 0.8. Find the weight of the alcohol.
7. A rectangular block of wood 5 x 10 x 20 cm. in dimensions weighs 770 grams. Find the density.
8. A thread of mercury in a fine cylindrical tube is 28 cm. long and weighs 11.9 grams. Find the internal diameter of the tube.
9. Write out the following photographic formulas, changing the weights to the metric system:—

DEVELOPER

Water.....	10 oz.
Metol.....	7 gr.
Hydroquinone.....	30 “
Sulphite of Soda (desiccated).....	110 “
Carbonate of Soda (desiccated).....	200 “
Ten per cent. solution Bromide of Potassium.....	40 drops

FIXING BATH

Water.....	64 oz.
Hyposulphite of Soda.....	16 “

When above is dissolved add the following solution:—

Water.....	5 “
Sulphite of Soda (desiccated).....	$\frac{1}{2}$ “
Acetic Acid.....	3 “
Powdered Alum.....	1 “

PART II—MECHANICS OF SOLIDS

CHAPTER II

DISPLACEMENT, VELOCITY, ACCELERATION

19. Position of a Point. If we wish to give the position of a place on the surface of the earth, or of a star in the sky, we first choose some reference lines or points, and then state the distance of the place or the star from these. In geography a place is precisely located by stating its longitude east or west from a certain meridian which passes through Greenwich, in England, and its latitude north or south of the equator. Thus Toronto is said to be in longitude $79^{\circ} 24'$ west and latitude $43^{\circ} 40'$ north. In astronomy a similar method is used, the corresponding terms being right ascension and declination.

In the same way we can locate the position of a house by referring it to two intersecting streets or roads.

Suppose we wish to state the position of a point P . Draw two lines of reference OX , OY . (Fig. 10.) Then if we know the

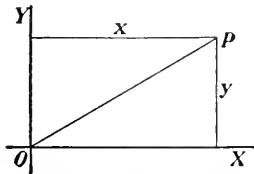

FIG. 10.—Locating a point by means of two lines of reference.

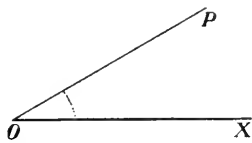

FIG. 11.—Locating a point by means of a length and an angle.

lengths x , y , of the two perpendiculars from P upon OY , OX we know the position of the point P with respect to the lines OX , OY , or to the point O .

Again, if the length OP (Fig. 11), and the angle made with the line of reference OX be known the position of P is definitely fixed.

20. Displacement. If a body is moved from O to P we say it has suffered a displacement OP . (Fig. 12.) Next let it be displaced from P to Q . It is evident that if we consider only change of position, the single displacement OQ is equivalent to the two displacements OP, PQ , though the length of path from O to Q by way of P is greater than that from O to Q directly.

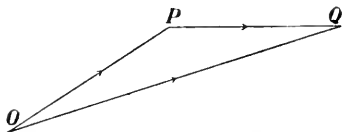

FIG. 12.—The addition of displacements.

The displacement OQ is the *resultant* of the two displacements OP, PQ , each of which is called a *component* displacement.

Next let a point suffer displacements represented in direction and magnitude by the lines OP, PQ, QR, RS ; then OS is the resultant of all these displacements. (Fig. 13.)

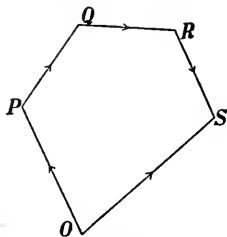

FIG. 13.—The addition of four displacements.

21. Velocity. Daily observation shows that to produce a displacement time is always required. When we travel on a railway we pay for the amount of our displacement but we are also concerned with the time consumed. This brings us to the idea of *velocity* or *speed*.

VELOCITY is the rate of change of position, or in other words, the time-rate of displacement.

Velocity involves the idea of direction. When we speak of the rate without reference to direction it is better to use the term *speed*.

If we travel 300 miles in 10 hours, our average speed is 30 miles per hour.



FIG. 14.—Average velocity is equal to the space divided by the time.

Let a body travel the distance AB , s centimetres, in t seconds; then

$$\text{Average velocity} = \frac{s}{t} = v \text{ centimetres per second.}$$

22. Uniform Velocity in a Straight Line. The velocities we have to deal with are usually not constant. On a long level track a railway train goes at an approximately uniform speed, though this changes when starting from, or approaching, a station. If the velocity is uniform in a straight line we have

$$\begin{aligned} \text{Space} &= \text{Velocity} \times \text{Time} \\ \text{or } s &= vt. \end{aligned}$$

Thus if $v = 150$ centimetres per second,
and $t = 20$ seconds,

$$\text{Then } s = 150 \times 20 = 3,000 \text{ centimetres.}$$

PROBLEMS

1. Find the equivalent, in feet per second, of a speed of 60 miles per hour.
2. An eagle flies at the rate of 30 metres per second; find the speed in kilometres per hour.
3. A sledge party in the arctic regions travels northward, for ten successive days, 10, 12, 9, 16, 4, 15, 8, 16, 13, 7 miles, respectively. Find the average velocity.
4. If at the same time the ice is drifting southward at the rate of 10 yards per minute, find the average velocity northward.

23. Acceleration. If the velocity of a particle is not uniform we say that the motion is accelerated. If the velocity increases, the acceleration is *positive*; if it decreases, the acceleration is *negative*. The latter is sometimes called a retardation.

Let a body move in a straight line, and measure its velocity. At one instant it is 200 cm. per second; 10 seconds later it is 350 cm. per second. The increase in the velocity acquired in 10 seconds is 150 cm. per second, and if this has been gained uniformly the increase per second will be 15 cm. per second. This is the *acceleration*.

If the velocity had decreased in 10 seconds to 50 cm. per second the loss of velocity would have been 150 cm. per second, and the loss *per second* would have been 15 cm. per second. In this case the acceleration is -15 cm. per second per second.

Observe the two time phrases "per second, per second." The first is used in stating the velocity gained (or lost), the second gives the time in which the velocity is gained (or lost).

ACCELERATION is rate of change of velocity.

PROBLEMS

1. A railway train changes its velocity uniformly in 2 minutes from 20 kilometres an hour to 30 kilometres an hour. Find the acceleration in centimetres per second per second.

2. A stone sliding on the ice at the rate of 200 yards per minute is gradually brought to rest in 2 minutes. Find the acceleration in feet and seconds.

3. Change an acceleration of 981 cm. per second per second into feet per second per second. (See Table, opposite page 1.)

24. Uniformly Accelerated Motion. Suppose the velocity of a particle at a given instant to be u centimetres per second, and let it have a uniform acceleration $+a$; *i.e.*, it gains in each second a velocity of a centimetres per second.

At the beginning, velocity $v = u$ cm. per sec.

At the end of 1 second, velocity $v = u + a$ " "

" " 2 seconds, " $v = u + 2a$ " "

" " 3 " " $v = u + 3a$ " "

... ..

and " " t " " $v = u + ta$ " "

Here the gain in velocity in 1 second is a cm. per second; the gain in t seconds is at cm. per second; and the velocity at the end of the t seconds is the original velocity + the gain, *i.e.*,

$$v = u + at \text{ cm. per sec.}$$

The change in the velocity due to uniform acceleration is equal to the product of the acceleration and the time.

If the initial velocity is zero we have $u = 0$, and

$$v = at \text{ cm. per sec.}$$

25. Average Velocity. Let a body start from rest and move for 10 sec. with a uniform acceleration of 8 cm. per sec. per sec. Then the velocities at the ends of the

1st.	2nd.	3rd.	4th.	5th.	6th.	7th.	8th.	9th.	10th.	sec.	
are	8	16	24	32	40	48	56	64	72	80	cm.
per sec., respectively.											

Thus, at the beginning the velocity is 0 cm. per sec.; at the end of 5 secs., 40 cm. per sec.; and at the end of 10 sec., 80 cm. per sec. The increase during the first half of the time is the same as that during the last half, and so the average velocity is one-half the sum of the initial and final velocities, *i.e.*, $\frac{1}{2}(0 + 80)$ or 40 cm. per sec.

If the initial velocity had been 5 cm. per sec. the velocities at the ends of the successive seconds would have been, respectively,

13, 21, 29, 37, 45, 53, 61, 69, 77, 85 cm. per. sec.

The average velocity is that possessed by the body at the middle of the time, or 45 cm. per sec., and this = $\frac{1}{2}(5 + 85)$, or is equal to one-half the sum of the initial and final velocities, as before.

26. Space Traversed. *First*, let the initial velocity be zero. In t seconds, with an acceleration a cm. per sec. per sec., the final velocity = at cm. per sec.

$$\begin{aligned} \text{The average or mean velocity} &= \frac{1}{2} (\text{Initial} + \text{Final velocity}). \\ &= \frac{1}{2} (0 + at). \\ &= \frac{1}{2} at \text{ cm. per sec.} \end{aligned}$$

This is the velocity when one-half the time has elapsed.

Now the space passed over

$$= \text{average velocity} \times \text{time};$$

hence if s represents space,

$$s = \frac{1}{2} at \times t = \frac{1}{2} at^2 \text{ cm.}$$

Next, let the initial velocity be u cm. per sec. Then we have:

$$\text{Initial velocity} = u \text{ cm. per sec.}$$

$$\text{Final " } = u + at \text{ cm. per sec.}$$

$$\begin{aligned} \text{Average " } &= \frac{1}{2} (u + u + at) \text{ cm. per sec.} \\ &= u + \frac{1}{2} at \quad \quad \quad \text{" "} \end{aligned}$$

$$\begin{aligned} \text{Then space } s &= \text{average velocity} \times \text{time} \\ &= (u + \frac{1}{2} at) t = ut + \frac{1}{2} at^2 \text{ cm.} \end{aligned}$$

In this expression note that ut expresses the space which would be traversed in time t with a uniform velocity u , and $\frac{1}{2} at^2$ is the space passed over when the initial velocity = 0. The entire space is then the sum of these.

27. Graphical Representation. The relations between velocity, acceleration, space and time in uniformly accelerated motion can be shown by a geometrical figure.

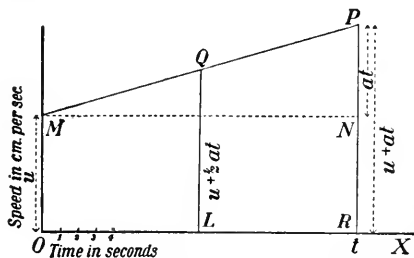

FIG. 15.—Space traversed can be represented by an area.

At the middle of the time the velocity is LQ .

The velocity at the beginning is $u = OM$. At the end of t seconds it is $u + at = RP$. Hence $NP = at$. The mean velocity is $u + \frac{1}{2} at = LQ$.

If the velocity is uniform (without acceleration), the space traversed is ut .

Now in the figure, $u = OM$ and $t = OR$,

Hence $ut = OM \times OR = \text{area of rectangle } MR$, and the space traversed is represented by the area of the rectangle.

Again with accelerated motion the space traversed is

$$(u + \frac{1}{2} at) \times t = ut + \frac{1}{2} at^2,$$

But $ut = \text{area of rectangle } MR$,

and $\frac{1}{2} at^2 = \text{area of triangle } MNP$.

Hence the space traversed is represented by the area of the figure $OMPR$.

28. Motion under Gravity. The most familiar illustration of motion with uniform acceleration is a body falling freely. Suppose a stone to be dropped from a height. At once it acquires a velocity downwards, which continually increases as it falls; and in a second or two it will be moving so fast that the eye can hardly follow it. In order to test experimentally the laws of motion we must devise some means of reducing the acceleration. The following is a simple and effective method of doing this.*

*Devised by Prof. A. W. Duff, of the Polytechnic Institute, Worcester, Mass.

In a board 5 or 6 feet long make a circular groove 4 inches wide and having a radius of 4 inches (Fig. 16). Paint the surface

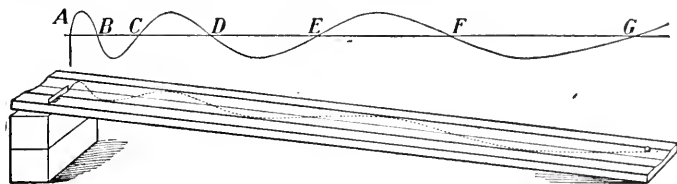

FIG. 16.—Apparatus to illustrate motion with uniform acceleration.

black and make it very smooth. Along the middle of the groove scratch or paint a straight line; and near one end of the board fasten a strip of brass, accurately at right angles to the length of the groove and extending just to the middle of it.

Lay the board flat on the floor, and place a sphere (a steel ball 1 in. to $1\frac{1}{2}$ in. in diameter), at one side of the groove and let it go. It will run back and forth across the hollow, performing oscillations in approximately equal times. By counting a large number of these and taking the average, we can obtain the time of a single one.

Next let one end of the board be raised and over the groove dust (through 4 or 5 thicknesses of muslin) lycopodium powder. Put the ball alongside the brass strip at one side of the groove and let it go. It oscillates across the groove and at the same time rolls down it, and the brass strip insures that it starts downwards without any initial velocity. By blowing the lycopodium powder away a distinct curve is shown like that in the upper part of Fig. 16.

It is evident that while the ball rolls down a distance AB it rolls from the centre line out to the side of the groove and back again; while it rolls from B to C , it rolls from the centre line to the other side of the groove and back again. These times are equal; let each be τ sec. (about $\frac{1}{3}$ sec.). In the same way CD , DE , EF and FG are each traversed in the same interval.

Now, $s = \frac{1}{2} at^2$, where s is the space, a is the acceleration and t is the time (§ 26).

$$\text{Hence } AB = \frac{1}{2} a\tau^2,$$

$$AC = \frac{1}{2} a (2\tau)^2 = 4 \times \frac{1}{2} a\tau^2 = 4 \times AB,$$

$$AD = \frac{1}{2} a (3\tau)^2 = 9 \times \frac{1}{2} a\tau^2 = 9 \times AB,$$

$$AE = \frac{1}{2} a (4\tau)^2 = 16 \times \frac{1}{2} a\tau^2 = 16 \times AB, \text{ etc.,}$$

i.e., the spaces AB , AC , AD , AE , etc., are proportional to 1, 4, 9, 16, etc.; or the distance is proportional to the square of the time.

By laying a metre scale along the middle of the groove these results can be tested experimentally.

The following are sample measurements obtained with 1 inch and $1\frac{1}{4}$ inch balls, rolling down a board 6 feet long. In the third, fifth and seventh columns are shown the ratios of AB , AC , AD , AE , AF , and AG to AB .

	1 inch ball. End raised 20 cm.		$1\frac{1}{4}$ inch ball. End raised 22 cm.		$1\frac{1}{4}$ inch ball. End raised $22\frac{1}{2}$ cm.	
	cm.	Ratio.	cm.	Ratio.	cm.	Ratio.
AB	4.55	1.0	4.40	1.0	4.45	1.0
AC	18.80	4.1	18.35	4.2	18.65	4.2
AD	40.40	8.9	39.50	9.0	40.25	9.0
AE	70.28	15.4	70.90	16.1	72.95	16.4
AF	111.90	24.6	108.45	24.6	111.00	24.9
AG	161.30	35.4	157.10	35.7	161.00	36.2

These ratios are very close to the theoretical values 1, 4, 9, 16, 25, etc., the discrepancies being due to unavoidable imperfections in the board, small inaccuracies in measurement, etc.

29. To Measure the Acceleration of Gravity. The acceleration given to a falling body by the attraction of the earth is usually denoted by the letter g . If we gradually increase the height from which a body is allowed to fall until at last it just reaches the ground in 1 second, we find the distance is about 16 feet. Now the measure of the acceleration is twice that of the space fallen through in the first second, and hence $g = 32$, approximately.

The most accurate method of measuring the value of g is by means of the pendulum. In this way it is found that, using feet and seconds, $g = 32.2$; and using centimetres and seconds, $g = 981$.

These values vary slightly with the position on the earth's surface. At the equator $g = 978.10$; at the pole, 983.11; at Toronto, 980.6.

30. All Bodies have the same Acceleration. Galileo asserted that all bodies, if unimpeded, fall at the same rate. Now, common observation shows that a stone or a piece of iron, for instance, falls much faster than a piece of paper or a feather. This is explained by the fact that the paper or the feather is more impeded by the resistance of the air.

From the top of the Leaning Tower of Pisa (see § 75), Galileo allowed balls made of various materials to fall, and he showed that they fell in practically the same time. Sixty years later, when the air-pump had been invented, the statement regarding the resistance of the air was verified in the following way. A coin and a feather were placed in a tube (Fig. 17) four or five feet long and the air was exhausted. Then, on inverting the tube, it was found that the two fell to the other end together. The more fully the air is removed from the tube the closer together do they fall.

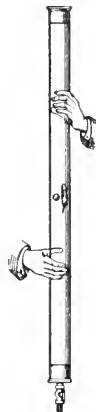

FIG. 17.—Tube to show that a coin and a feather fall in a vacuum with the same acceleration.

31. Relation between Velocity and Space.

We have found

$$v = at, \text{ or } t = \frac{v}{a}; \quad (\S 24)$$

$$\text{also } s = \frac{1}{2} at^2. \quad (\S 26).$$

Putting in this latter equation the value of t from the former we have

$$s = \frac{1}{2} a \left(\frac{v}{a} \right)^2 = \frac{1}{2} \frac{v^2}{a}$$

or $v^2 = 2as.$

Also, we have

$$v = u + at, \text{ or } t = \frac{v-u}{a}; \quad (\S 24)$$

$$\text{and } s = ut + \frac{1}{2} at^2. \quad (\S 26).$$

Putting in the latter equation the value of t from the former, we obtain

$$s = u \left(\frac{v-u}{a} \right) + \frac{1}{2} a \left(\frac{v-u}{a} \right)^2;$$

and on simplifying this expression we have

$$v^2 = u^2 + 2as.$$

NUMERICAL EXAMPLES

The meaning of the relations between velocity, acceleration, time and space, expressed by formulas in §§ 24, 26, 31, can best be comprehended by considering some numerical examples.

1. A person at the top of a tower throws a stone downwards with a velocity of 8 m. per sec., and it reaches the ground in 3 sec. Find the velocity with which the stone strikes the ground, and the height of the tower.

Here we have $u = 800$ cm. per second,

$$t = 3 \text{ sec.},$$

$$a = 980 \text{ cm. per second per second.}$$

But $v = u + at$,

that is $= 800 + 980 \times 3 = 3740$ cm. per sec.

Again $s = ut + \frac{1}{2} at^2$.

that is $= 800 \times 3 + \frac{1}{2} \times 980 \times 9 = 6810$ cm. (Height of tower).

If the stone is simply dropped instead of being thrown downwards, and reaches the ground in 3 sec., we have

$$u = 0;$$

also $v = at = 980 \times 3 = 2940$ cm. per sec.,

and $s = \frac{1}{2} at^2 = \frac{1}{2} \times 980 \times 9 = 4410$ cm.

2. A bullet is shot upwards with a velocity of 1500 m. per sec. How high will it rise? How long will it take to reach the ground again?

In this case $u = 1500$ cm. per sec.,

$$a = -980 \text{ (acceleration is negative).}$$

The bullet continues to rise until, on reaching its highest point, its velocity is zero.

But $v^2 = u^2 + 2as$ (§ 31);

and putting $v = 0$, $u = 1500$, $a = -980$,

we have $0^2 = (1500)^2 + 2 \times (-980) \times s$;

from which $s = 1148$ (nearly) cm. (Height of path).

Again, the bullet loses every second 980 cm. per sec. of its velocity. But by the time it reaches the top of its path it has lost its entire velocity of 1500 cm. per sec.

Hence the time going up $= \frac{1500}{980} = 1.53 \dots$ seconds.

The bullet will then begin to descend, and as it will gain 980 cm. per sec. during every second of its fall, it will require the same time to fall as it did to rise, and it will have, on reaching the ground, a velocity as great as it had on starting upwards, but in the opposite direction.

Hence the time which has elapsed from its leaving the ground until it returns is $2 \times 1.53 = 3.06$ seconds.

In both these examples the resistance of the atmosphere has been disregarded, though its effect is considerable in the case of rapidly-moving or light bodies.

In all examples involving the metric system of units it will generally be found advisable to express all lengths in centimetres, all masses in grams and all times in seconds.

PROBLEMS

Unless otherwise stated, take as the measure of the acceleration of gravity, with centimetres and seconds, 980 ; with feet and seconds, 32.

1. A body moves 1, 3, 5, 7 feet during the 1st, 2nd, 3rd, 4th seconds, respectively. Find the average speed.

2. Express a speed of 36 kilometres per hour in cm. per second.

3. A body falls freely for 6 seconds. Find the velocity at the end of that time, and the space passed over.

4. The velocity of a body at a certain instant is 40 cm. per sec., and its acceleration is 5 cm. per sec. per sec. What will be its velocity half-a-minute later ?

5. What initial speed upwards must be given to a body that it may rise for 4 seconds ?

6. The Eiffel Tower is 300 metres high, and the tower of the City Hall, Toronto, is 305 ft. high. How long will a body take to fall from the top of each tower to the earth ?

7. On the moon the acceleration of gravity is approximately one-sixth that on the earth. If on the moon a body were thrown vertically upwards with a velocity of 90 feet per second, how high would it rise, and how long would it take to return to its point of projection ?

8. A body moving with uniform acceleration has a velocity of 10 feet per second. A minute later its velocity is 40 feet per second. What is the acceleration ?

9. A body is projected vertically upward with a velocity of 39.2 metres per second. Find

- (1) how long it will continue to rise ;
- (2) how long it will take to rise 34.3 metres ;
- (3) how high it will rise.

10. A stone is dropped down a deep mine, and one second later another stone is dropped from the same point. How far apart will the two stones be after the first one has been falling 5 seconds ?

11. A balloon ascends with a uniform acceleration of 4 feet per second per second. At the end of half-a-minute a body is released from it. How long will it take to reach the ground ?

12. A train is moving at the rate of 60 miles an hour. On rounding a curve the engineer sees another train $\frac{1}{4}$ mile away on the track at rest. By putting on all brakes a retardation of 3 feet per second per second is given the train. Will it stop in time to avoid a collision ?

32. Motion in a Circle. Let a body M be made to revolve uniformly in a circle with centre O and radius r . A familiar illustration of this motion is seen when a stone at the end of a string is whirled about.

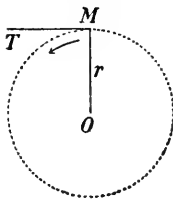

FIG. 18.—Motion in a circle.

In this case the length of the line MO does not alter, and yet M has a velocity with respect to O . This arises from the continual change in the direction of the line MO . Every time the body describes a circle its direction changes through 360° .

If the string were cut and M were thus allowed to continue with the velocity it possessed, it would move off in the tangent to the circle MT . This effect is well illustrated by the drops of water flying off from the wheels of a bicycle, or the sparks from a rapidly rotating emery wheel.

We see, then, that *one point has a velocity with respect to another when the line joining them changes in magnitude or direction.*

In the above case there is a change of velocity (being a continual change from motion in one tangent to motion in another), and hence there is an acceleration; and as the change in the velocity is uniform the acceleration is constant. The acceleration is always directed towards the centre of the circle.

33. Translation and Rotation. If a body move so that all points have the same speed and in the same direction we say that it has a motion of *translation*. Examples: the car of an elevator, or the piston of an engine.



FIG. 19.—Showing motion of translation.

If, however, a body move so that all points of it move in circles having as centre a point called the centre of mass, or centre of gravity,* the motion is a *pure rotation*. Example: a wheel on a shaft, such as the wheel of a sewing-machine or a fly-wheel.

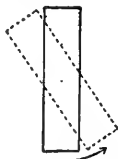

FIG. 20.—Showing motion of rotation.

Usually, however, both motions are present, that is, the body has both translation and rotation. Examples: the motions of the planets, of a carriage wheel, of a body thrown up in the air.

If a body is rotating about an axis through a point O in it, it is evident that those points which are near O , such as P, Q (Fig. 21), have smaller speeds than have those points such as R, S , which are farther away.

*Explained in Chapter VII

But they all describe circles about O in the same time and hence their *angular velocities* are all equal.

Again, consider the motions of A and B with respect to each other. To a person at A the point B will revolve about him in the same time as the body rotates about O . Also, a person at B will see A revolve about him in the same time.

For instance, suppose the body to rotate once in a second. All lines in the body will change their directions in the same manner, turning through 360 degrees, and returning to their former positions at the end of a second.

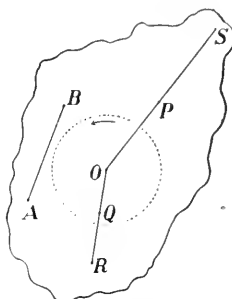

FIG. 21.—In a rotating body all points have the same angular velocity.

34. Composition of Velocities. Suppose a passenger to be travelling on a railway train which is moving on a straight track at the rate of 15 miles per hour, or 22 feet per second. While sitting quietly in his seat he has a motion of translation, in the direction of the track, of 22 feet per second.

Next let the passenger rise and move directly across the car, going a distance of 6 feet in 2 seconds. His velocity across will be 3 feet per second.

In Fig. 22, A is the position of the passenger at first. If the train were at rest, in 2 seconds he would move from A to C , 6 feet;

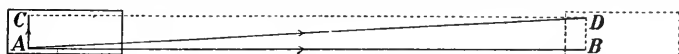

FIG. 22.—Motion of a passenger walking across a moving railway car.

while, if he sat still the train in its motion would carry him from A to B in 2 seconds, a distance of 44 feet. It is evident, then, that if the train move forward and the passenger move across at the same time, at the end of 2 seconds he will be at D , *i.e.*, 44 feet forward and 6 feet across.

Moreover at the end of 1 second he will be 22 feet forward and 3 feet across, that is, half way from A to D . The motions which he has will carry him along the line AD in 2 seconds.

35. Law of Composition.

Another example will perhaps make clearer this principle of compounding velocities.

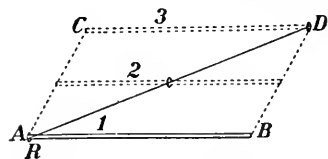

FIG. 23.—Showing how to add together two motions of a ring on a rod.

Let a ring R slide with uniform velocity along a smooth rod AB , moving from A to B in 1 second. At the same time let the rod be moved in the direction AC with a uniform velocity, reaching the position CD in a second. The ring will be at D at the end of a second.

At the end of half-a-second from the beginning the ring will be half-way along the rod, and the rod will be in position (2) half-way between AB and CD . It is evident that between the two motions the ring will move uniformly along the line AD , travelling this distance in 1 second.

From these illustrations we can at once deduce the law of composition of velocities.

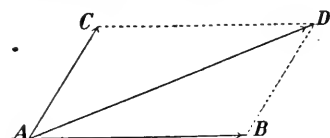

FIG. 24.—The parallelogram of velocities. DC . Then the diagonal AD will represent in magnitude and direction the resultant velocity.

Let a particle possess two velocities simultaneously, one represented in direction and magnitude by the line AB , the other by AC .

Complete the parallelogram $ABDC$. Then the diagonal AD will represent in magnitude and direction the resultant velocity.

Hence to find the resultant of two simultaneous velocities we have the following rule:—

Construct a parallelogram whose adjacent sides represent in magnitude and direction the two velocities; then the diagonal which lies between them will represent their resultant.

Each velocity AB , AC is called a *component*; AD is the *resultant*.

If there are more than two component velocities, such as AB , AC , AD , AE , proceed in the following way.

Find the resultant of AB and AC ; it is AF . Next, the resultant of AF and AD is AG ; and finally, the resultant of AG and AE is AH . Thus AH is the resultant of the four velocities AB , AC , AD , AE .

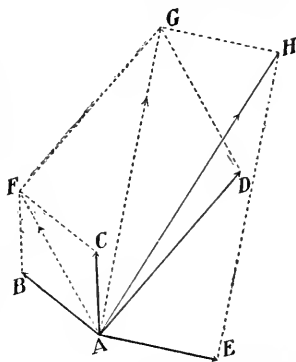

FIG. 25.—How to combine more than two velocities.

36. Resolution into Components.

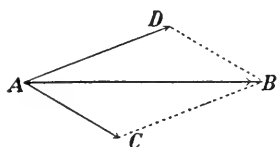

FIG. 26.—If a velocity be represented by the diagonal of a parallelogram, the adjacent sides will represent its components.

Suppose now a body to have a velocity represented by the line AB . This may be any length we choose. Let us describe a parallelogram having AB as its diagonal. It is evident that the velocity represented by AB is the resultant of the velocities represented by AC , AD . In this way we are said to resolve the velocity AB into components in the directions AC , AD .

NUMERICAL EXAMPLES

1. Suppose a vessel to steam directly east at a velocity of 12 miles per hour, while a north wind drifts it southward at a velocity of 5 miles an hour. Find the resultant velocity.

Draw a line AB , 12 cm. long, to represent the first component velocity; AC , 5 cm. long, to represent the second. (Fig. 27.)

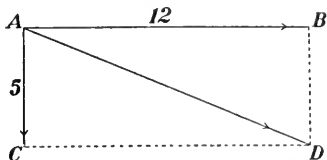

FIG. 27.—Illustrating the motion of a vessel.

Completing the parallelogram, which in this case is a rectangle, AD will represent the resultant velocity.

Here we have $\overline{AD}^2 = \overline{AB}^2 + \overline{BD}^2 = 12^2 + 5^2 = 169 = 13^2$.

Hence $AD = 13$, *i.e.*, the resultant velocity is 13 miles per hour in the direction represented by AD .

2. A ship moves east at the rate of $7\frac{1}{2}$ miles per hour, and a passenger walks on the deck at the rate of 3 feet per second. Find his velocity relative to the earth in the following three cases, (1) when he walks towards the bow, (2) towards the stern, (3) across the deck.

3. A ship sails east at the rate of 10 miles per hour, and a north-west wind drives it south-east at the rate of 3 miles per hour. Find the resultant velocity.

To calculate the resultant accurately requires a simple application of trigonometry, but the question can be solved approximately by drawing a careful diagram. Draw a line in the easterly direction 10 inches long, and lay off from this, by means of a protractor, a line in the south-east direction, 3 inches long. Complete the parallelogram and measure carefully the length of the diagonal. (13.92 miles per hour.)

4. Find the resultant of two velocities 20 cm. per second and 50 cm. per second (*a*) at an angle of 60° , (*b*) at an angle of 50° . (Carefully draw diagrams, and measure the diagonals.)

5. A particle has three velocities given to it, namely, 3 feet per second in the north direction, 4 feet per second in the east direction, and 5 feet per second in the south-east direction. Find the resultant. (Carefully draw a diagram.)

37. The Triangle and the Polygon of Velocities. The law

for compounding velocities may be stated in a somewhat different form.



FIG. 28.—Representation of two velocities.

Let a particle have two velocities represented by AB , CD , respectively (Fig. 28). If we form a parallelogram having AB , CD

as adjacent sides, then we know that the diagonal represents the resultant. (Fig. 29.)

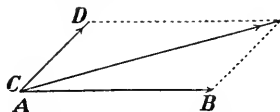

FIG. 29.—Parallelogram of velocities.

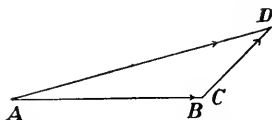

FIG. 30.—Triangle of velocities.

Suppose, however, that we draw the line representing the velocity CD , not from A but from B (Fig. 30). Then on joining AD we form a triangle which is just one-half of the parallelogram in Fig. 29, and the side AD of the triangle is equal to the diagonal of the parallelogram. It represents therefore the resultant of AB , CD .

We have then the following law :

If a body have two simultaneous velocities, and we represent them by the two sides AB , BC of a triangle, taken in order, then the resultant of the two velocities will be represented by the third side AC of the triangle.

Next, let the body have several simultaneous velocities, represented by the lines A , B , C , D .

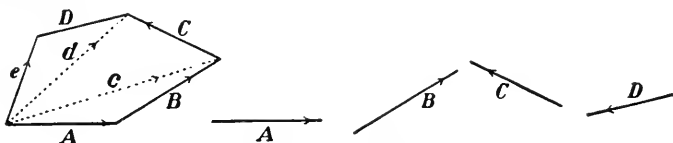

FIG. 31.—Polygon of velocities.

Place lines representing these velocities end to end so as to form four sides of a polygon, as in Fig. 31. Then the resultant of A and B is c , the resultant of c and C is d , and the resultant of d and D is e , which is therefore the resultant of A , B , C , D .

Hence we have the following law :

If a body have several simultaneous velocities, and we represent them as sides of a polygon, taken in order, then the closing side of the polygon will represent the resultant of all the velocities.

38. Composition of Accelerations. A body may possess simultaneous accelerations, and as these can be represented in the same way as displacements and velocities, they may be combined in precisely the same way as displacements and velocities.

In fact any physical quantities which can be represented in magnitude and direction by straight lines may be combined according to the polygon law. Such directed quantities are known as *vectors*.

CHAPTER III

INERTIA, MOMENTUM, FORCE

39. Mass, Inertia. The *mass* of a body has been defined (§ 11) as the quantity of matter in it. Just what *matter* is no one can say. We all understand it in a general way, but we cannot explain it in terms simpler than itself. We must obtain our knowledge regarding it by experience.

When we see a young man kick a football high into the air we know that there is not much *matter* in it. If it were filled with water or sand, so rapid a motion could not be given to it so easily, nor would it be stopped or caught so easily on coming down. A cannon ball of the same size as the football, and moving with the same speed, would simply plough through all the players on an athletic field before it would be brought to rest.

In the same way, by watching the behaviour of a team hitched to a wagon loaded with barrels, we can tell whether the barrels are empty or filled with some heavy substance.

To a person accustomed to handling a utensil made of iron or enamelled-ware, one made of aluminium seems singularly easy to move. A bottle filled with ordinary liquids is picked up and handled with ease, but one never fails to feel astonished at the effort required to pick up a bottle filled with mercury.

In every instance that body which demands the expenditure of a great effort in order to put it in motion, or to stop it, has *much matter* in it, or has a *great mass*.

Our experience thus leads us to conclude,

First, that it requires an effort to put in motion matter which is at rest, or to stop matter when in motion ;

Second, that the amount of the effort depends on the amount of matter, or the mass of the body, which is put in motion or brought to rest.

When we say that *all matter possesses inertia* we mean just what the first of the above statements says; while the second states that the inertia of a body is proportional to its mass.

40. Momentum. We have seen that the greater the mass of a body the more difficult it is to set it in motion or to stop it when it is in motion. Now, very little consideration will lead us to recognize that we must also take into account the velocity which a body has. It requires a much greater effort to impart a great velocity to a body than to give it a small one; and to stop a rapidly moving body is much harder than to stop one moving slowly. We feel that there is something which depends on both mass and velocity, and which we can think of as *quantity of motion*. This is known in physics as *momentum*. It is proportional to both the mass and the velocity of the body, thus

$$\begin{aligned}\text{Momentum} &= \text{mass} \times \text{velocity}, \\ &= mv,\end{aligned}$$

where m is the mass of the body and v its velocity of translation.

Momentum is a directed quantity, and hence (§ 38) momenta can be compounded by the parallelogram or polygon law.

QUESTIONS AND PROBLEMS

1. Why are quoits made in the shape of a ring and not as discs cut from a metallic sheet?
2. Why is it that in the balance wheel of a watch most of the material is placed near the rim?
3. Compare the momentum of a car weighing 50,000 kilograms and moving with a velocity of 30 kilometres an hour with that of a cannon ball weighing 20,000 grams and moving with a velocity of 50,000 cm. per second.

4. A man weighing 150 pounds and running with a velocity of 6 feet per second collides with a boy of 80 pounds moving with a velocity of 9 feet per second. Compare the momenta.

41. Newton's Laws of Motion: the First Law. In his "Principia,"* published in 1687, Sir Isaac Newton stated, with a precision and clearness which cannot be improved, the fundamental laws of motion.

The *First Law* is as follows :—

Every body continues in its state of rest, or of uniform motion in a straight line, unless it be compelled by external force to change that state.

This Law states what happens to a body when it is left to itself. Now, on the surface of the earth it is very difficult, impossible indeed, to leave a body entirely to itself, but the more nearly we come to doing so the more nearly do we demonstrate the truth of the Law.

This Law is but a statement, in precise form, of the principle of inertia as explained in §39.

42. Illustrations of the First Law.

(a) A lump of dead matter will not move itself.

(b) A ball rolling on the grass comes to rest. The external force is the friction of the ball on the grass. If we roll it on a smooth pavement the motion persists longer, and if on smooth ice, longer still. It is seen that as we remove the external force (of friction), and leave the body more and more to itself the motion continues longer, and we are led to believe that if there were no friction it would continue uniformly in a straight line.

(c) An ordinary wheel if set rotating soon comes to rest. But a well-adjusted bicycle wheel if put in motion will continue to move



SIR ISAAC NEWTON (1642-1727) at the age of 83. Demonstrated the law of gravitation. The greatest of mathematical physicists.

*The full title of the book is "Principia Mathematica Naturalis Philosophiæ," i.e., "The Mathematical Principles of Natural Philosophy."

for a long time. Here the external force—the friction at the axle—is made very small, and the motion persists for a long time.

As illustrations of the law of inertia we may consider the following.

(a) When a locomotive, running at a high rate of speed, leaves the rails and is rapidly brought to a standstill, the cars behind do not immediately stop, but continue ploughing ahead, and usually do great damage before coming to rest.

(b) If one wishes to jump over a ditch he takes a run, leaps up into the air, and his body persisting in its motion reaches the other side.

(c) In an earthquake the buildings tend to remain at rest while the earth shakes under them, and they are broken and crumble down.

The evidence supporting the First Law is of a negative character; and since in all our experience we have never found anything contrary to it, but as, on the other hand, it is in accordance with all our experience and observation, we cannot but conclude that it is exactly true.

43. Newton's Second Law of Motion. *Change of momentum, in a given time, is proportional to the impressed force and takes place in the direction in which the force acts.*

If there is a change in the condition of a body (*i.e.*, if it does not remain at rest or in uniform motion in a straight line), then there is a change in its momentum, that is, in the *quantity of motion* it possesses. Any such change is due to some external influence which is called **FORCE** and the amount of the change in a given length of time is proportional to the impressed force. It is evident, also, that the total effect of a force depends on the length of time during which it acts. Again, force acts in some direction, and the change of momentum is in that direction.

The word force is used, in ordinary conversation, in an almost endless number of meanings, but in Physics the meaning is definite. If there is a change of momentum, force is acting.

Sometimes, however, a body is not free to move. In this case force would *tend* to produce a change in the momentum. We can include such cases by framing our definition thus:

FORCE is that which tends to change momentum.

It is to be observed that there is no suggestion as to the cause or source of force. Whatever the nature of the external influence on the body may be, we simply look at the effect: if there has been a change of momentum, then it is due to force.

It is evident, also, that the total effect of a force depends upon the time it acts.

Thus, suppose a certain force to act upon a body of mass m for 1 second, and let the velocity generated be v , *i.e.*, the momentum produced is mv . If the force continues for another second it will generate additional velocity v , or $2v$ in all, and the momentum produced will be $2mv$; and so on.

Let us state this result in symbols.

Let F represent the force,

and t sec. be the time during which it acts.

At the end of t sec. the force will have generated a certain momentum, which we may write mv .

Then

Force \times time = momentum produced,

$$\text{or } Ft = mv.$$

$$\text{Hence } F = \frac{mv}{t},$$

$$= m \times \frac{v}{t},$$

$$= ma.$$

i.e. Force = mass \times acceleration.

It should be remarked that this equation holds only when we choose proper units. However, F is always *proportional* to the quantity ma .

44. Units of Force. In further explanation of the action of force, consider the following arrangement.

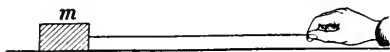

FIG. 32.—A stretched elastic cord exerting force on a mass.

A mass of m grams rests on a smooth surface (that is, a surface which exerts no friction as the mass moves over it), and to it is attached an elastic cord the natural length of which is 20 cm. Let the mass be held until the cord is stretched to a length of 25 cm., and then let go. The force exerted on the mass by the stretched cord will cause it to move.

If the hand continually moves forward fast enough to keep the length of the cord always 25 cm., then the same force will continually act upon m .

The effect of the force will be to give a velocity to m , *i.e.*, to generate momentum.

At the end of 1 second let the velocity be a cm. per second; at the end of 2 seconds it will be $2a$ cm. per second; at the end of 3 seconds, $3a$ cm. per second; and at the end of t seconds, at cm. per second. In this case there is given to the mass m an acceleration of a cm. per second per second.

If now the mass is 1 gram and the gain in velocity every second is 1 cm. per second (or, in other words, the acceleration is 1 cm. per second per second), then the force which produced this is called a *dynes*.

If the mass is 1 gram and the acceleration is a cm. per second per second, the force a dynes.

If the mass is m grams and the acceleration is a centimetres per second per second, the force is $m a$ dynes. If F represent this force, then

$$F = m a,$$

or Force = mass \times acceleration, as obtained in § 43.

A **DYNE** is that force which acting on 1 gram mass for 1 sec. will generate a velocity of 1 cm. per sec.

If the mass is 1 pound and the acceleration is 1 foot per second per second the force is called a *poundal*.

We can write

1 poundal acting on 1 lb. mass for 1 sec. gives a velocity of 1 ft. per sec.

F poundals " " 1 " " 1 " " " " F " "

F " " " m lbs. " 1 " " " " $\frac{F}{m}$ " "

F " " " m " " t " " " " $\frac{Ft}{m}$ " "

Let this velocity be v feet per second.

$$\text{Then } \frac{Ft}{m} = v, \text{ or } Ft = mv,$$

$$\text{and } F = \frac{mv}{t} = ma, \text{ as before.}$$

A **POUNDAL** is that force which acting on 1 lb. mass for 1 sec. generates a velocity of 1 ft. per sec.

45. Average Force. If the momentum generated in the interval t be mv , then

$$Ft = mv$$

$$\text{and } F = \frac{mv}{t}.$$

If the force has not been constant all the time the above value is the *average force* acting during the interval.

PROBLEMS

1. A mass of 400 grams is acted on by a force of 2000 dynes. Find the acceleration. If it starts from rest, at the end of 5 sec., (1) the velocity generated, (2) the momentum.

2. A force of 10 dynes acts on a body for 1 min., and produces a velocity of 120 cm. per sec. Find the mass, and the acceleration.

3. Find the force which in 5 sec. will change the velocity of a mass of 20 grams from 30 cm. per sec. to 80 cm. per sec.

4. A force of 50 poundals acts on a mass of 10 lb. for 15 sec. Find the velocity produced, the acceleration and the momentum.

46. Gravitation Units of Force. The force with whose effects we are most familiar is the *force of gravitation*, and we shall express the dyne and poundal in terms of it.

Take a lump of matter the mass of which is 1 gram. The earth pulls it downward with a force which we call a gram-force.

If now it is allowed to fall freely, at the end of 1 second it will have a velocity of 980 (approximately) centimetres per second.

We see then that

1 gm.-force acting on 1 gm.-mass for 1 sec. gives a velocity of 980 cm. per sec. ;
 but 1 dyne " " " " " 1 " " " " 1 " "

Hence 1 dyne = $\frac{1}{980}$ of a gram-force.

The gram-force is a small quantity, while the dyne is $\frac{1}{980}$ of this and so is a *very* small quantity.

Using pounds and feet as units we have

1 pound-force acting on 1 lb.-mass for 1 sec. gives a velocity of 32 ft. per sec. ;
 but 1 poundal " " 1 " " 1 " " " " 1 " "

Hence 1 poundal = $\frac{1}{32}$ pound-force
 = $\frac{1}{2}$ ounce-force.

Here 980 and 32 are only approximate values of the acceleration of gravity; they vary with the position on the earth's surface. On the other hand the dyne and the poundal are quite independent of position in the universe, and they are therefore known as *absolute* units of force.

47. Composition and Resolution of Forces. Since acceleration is a directed quantity, and $F = ma$, it follows that force is also a directed quantity, and can therefore be represented in magnitude and direction by a straight line.

Just as displacements, velocities, accelerations and momenta may be combined and resolved according to the parallelogram or polygon law, so may forces.

48. Independence of Forces. It is to be observed that each force produces its own effect, measured by change of momentum, quite independently of any others which may be acting on the body.

Suppose now a person to be at the top of a tower 64 feet high. If he drops a stone it will fall vertically downward and will reach the ground in 2 seconds. Next, let it be thrown outward in a horizontal direction. Will it reach the ground as quickly?

By the *Second Law* the force which gives to the stone an *outward* velocity will act quite independently of the force of gravity which gives the *downward* velocity. A horizontal velocity can have no effect on a vertical one, either to increase or to diminish it. Hence the body should reach the ground in 2 seconds, just the same as if simply dropped.

This result can be experimentally tested in the following way:

A and *B* are two upright supports through which a rod *R* can slide. *S* is a spring so arranged that when *R* is pulled back and let go it flies to the right. *D* is a metal sphere through which a hole is bored to allow it to slip over the end of *R*. *C* is another sphere, at the same height above the floor as *D*.

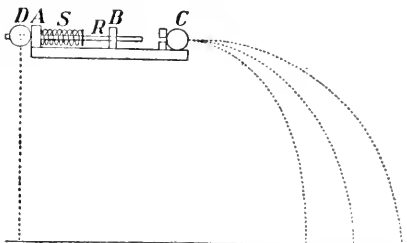

FIG. 33.—The ball *C*, following a curved path reaches the floor at the same time as *D* which falls vertically.

The rod *R* is just so long that when it strikes *C*, the sphere *D* is set free. Thus *C* is projected horizontally outwards while *D* drops directly down.

By pulling *R* back to different distances, different velocities can be given to *C*, and thus different paths described, as shown in the figure.

It will be found that no matter which of the curved paths *C* takes it will reach the floor at the same time as *D*.

PROBLEMS

1. From a window 16 ft. above the ground a ball is thrown in a horizontal direction with a velocity of 50 ft. per second. Where will it strike the ground?

[It will reach the ground in 1 sec., and will therefore strike the ground 50 feet from the house.]

2. A cannon is discharged in a horizontal direction over a lake from the top of a cliff 19.6 m. above the water, and the ball strikes the water 2500 m. from shore. Find the velocity of the bullet outwards, supposing it to be uniform over the entire range.

3. In problem 2 find the velocity downwards at the moment the ball reaches the water; then draw a diagram to represent the horizontal and vertical velocities, and calculate the resultant of the two.

49. Newton's Third Law of Motion. The Third Law relates to actions between bodies, and is as follows :

To every action there is always an equal and opposite reaction.

The statement of this law draws our attention to the fact that force is a two-sided phenomenon. If a body *A* acts on a body *B*, then *B* reacts upon *A* with equal force.

When we confine our attention to one body we look on the other body as the seat of an *external* force; but when we take both bodies into account we see the dual nature of the force.

If one presses the table with his hand, there is an upward pressure exerted on the hand by the table.

A weight is suspended by a cord: the downward pull exerted by the weight is equal to the upward pull exerted by the support to which the cord is fastened.

In the first of these examples action and reaction are both pressures; in the second they are tensions.

If motion takes place the action and reaction are measured by the change of momentum.

Thus, when a person jumps from a boat to the shore the momentum of the boat backward is equal to the momentum of the person forward.

When an apple falls to the earth, the earth moves upward to meet the apple, the momentum in each case being the same; but the mass of the earth is so great that we cannot detect its velocity upward.

When a pole of one magnet attracts or repels a pole of a second magnet, the latter exerts an equal attraction or repulsion on the first. In this case we cannot detect any material cord or rod connecting the two poles, along which is exerted a tension or a pressure; but it is probable, nevertheless, that there is something in the space between which transmits the action.

The following experiment will illustrate the third law :

A and *B* are two exactly similar ivory or steel balls, suspended side by side. *A* is drawn aside to *C*, and then allowed to fall and strike *B*. At once *A* comes to rest, and *B* moves off with a velocity equal to that which *A* had.

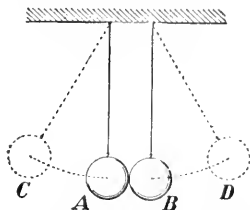

FIG. 34.—The action of *A* on *B* is equal to the reaction of *B* on *A*.

Here the *action* is seen in the forward momentum of *B*, the *reaction* in the equal momentum in opposite direction which just brings *A* to rest. Of course, if we call the latter the *action*, the former is the *reaction*.

Suppose now *A* and *B* to be sticky putty balls so that when they collide they stick together; they will both move forward with one-half the velocity which *A* had on striking. The student can easily analyse the phenomenon in this case into action and reaction.

PROBLEMS

1. If the sphere *B* (Fig. 34) has a mass twice as great as *A*, what will happen (1) when *A* and *B* are of ivory? (2) when they are of sticky putty?

2. A hollow iron sphere is filled with gunpowder and exploded. It bursts into two parts, one part being one quarter of the whole. Find the relative velocities of the fragments.

3. Suspend an iron ball (Fig. 35) about 3 inches in diameter with ordinary thread. By pulling slowly and steadily on the cord below the sphere the cord above breaks, but a quick jerk will break it below the ball. Apply the third law to explain this.



FIG. 35.—An iron ball suspended by a thread.

4. A rifle weighs 8 lbs. and a bullet weighing 1 oz. leaves it with a velocity of 1500 ft. per sec. Find the velocity with which the rifle recoils.

5. Sometimes in putting a handle in an axe or a hammer it is accomplished by striking on the end of the handle. Explain how the law of inertia applies here.

CHAPTER IV

MOMENT OF A FORCE; COMPOSITION OF PARALLEL FORCES; EQUILIBRIUM OF FORCES

50. Moment of a Force. In stormy weather, in order to

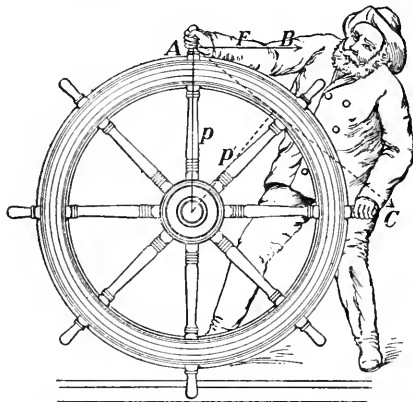

keep the ship on her course the wheelsman grasps the wheel at the rim (*i.e.*, as far as possible from the axis), and exerts a force at right angles to the line joining the axis to the point where he takes hold. (Fig. 36.)

FIG. 36.—The moment of a force depends on the force applied and its distance from the axis of rotation.

From our experience we know that the turning effect upon the wheel is proportional to the force exerted and also to the

distance, from the axis, of the point where the force is applied.

Let F = the force applied,

p = the perpendicular distance from the axis to the line AB of the applied force.

Then the product Fp measures the tendency of the wheel to turn, or the tendency to produce angular momentum. This product is the *moment of the force*, which is defined as follows:

The MOMENT OF A FORCE is the tendency of that force to produce rotation of a body.

If the direction of the force F is not perpendicular to the line joining its point of application to the axis, the moment is not so great, since part of the force is spent uselessly in pressing the wheel against its axis. In Fig. 36, if AC is the new direction of the force, then p' , the new perpendicular, is shorter than p , and hence the product Fp' is smaller.

51. Experiment on Law of Moments. We can experimentally test the law of moments in the following way.

AB is a rod which can move freely about a pin driven in a board at O , and two cords attached to the ends A and B pass over pulleys at the edge of the board. Adjust these until the perpendicular distances from O upon the strings are 3 inches and 5 inches. Then if the weight $P = 10$ oz., the weight Q , to balance the other, must = 6 oz.

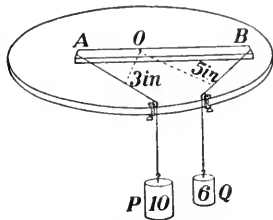

FIG. 37.—Apparatus for testing the law of moments.

Here moment of force P is $10 \times 3 = 30$,

and " " " Q is $6 \times 5 = 30$.

For equilibrium of the two moments, the products of the forces by the perpendicular distances must be the same, and they must tend to produce rotations in opposite directions.

52. Forces on a Crooked Rod. For a body shaped as in Fig. 38,

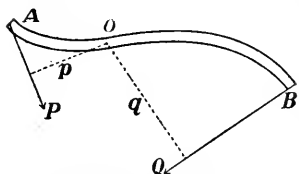

FIG. 38.—Balancing forces on a rod which is not straight.

with forces P and Q acting at the ends A and B , the moment of P about O is Pp , that of Q is Qq ; but it is to be observed that they turn the rod in opposite directions. If we call the first positive, the other will be negative, and the entire tendency of the rod to rotate will be

$$Pp - Qq.$$

If $Pp - Qq = 0$, the rod will be in equilibrium.

53. Composition of Parallel Forces. The behaviour of parallel forces acting on a rigid body may be investigated experimentally in the following way:

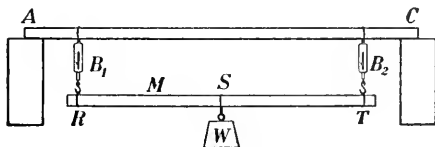

FIG. 39.

M is a metre stick (Fig. 39) with a weight W suspended at its centre of gravity, and two spring balances B_1, B_2 , held up by the

rod AC , support the stick and the weight. Be careful to have the balances hanging vertically.

Take the readings of the balances B_1, B_2 ; let them be P and Q , respectively. Also, measure the distances RS, ST .

Then we shall find that if the weight of the stick and W together is U ,

$$P + Q = U \text{ and } P \times RS = Q \times ST.$$

Again, if we take moments about R we should have

$$U \times RS = Q \times RT.$$

By shifting the position of R and T , various readings of the balances will be obtained.

PROBLEMS

1. A rod is 4 feet long (Fig. 40) and one end rests on a rigid support. At distances 12 inches and 18 inches from that end weights of 20 lbs. and 30 lbs., respectively, are hung. What force must be exerted at the other end in order to support these two weights? (Neglect the weight of the rod.)



FIG. 40.—What force is required to lift the weights?

2. An angler hooks a fish. Will the fish appear to pull harder if the rod is a long or a short one?
3. A stiff rod 12 feet long, projects horizontally from a vertical wall. A weight of 20 lbs. hung on the end will break the rod. How far along the pole may a boy weighing 80 lbs. go before the pole breaks?

54. Unlike Parallel Forces.—Couple. Let P, P be two equal parallel forces acting on a body in opposite directions (Fig. 41). The entire effect will be to give the body a motion of rotation without motion of translation.

Such a pair of forces is called a *couple*, and the moment of the couple is measured by the product of the force into the perpendicular distance between them. Thus if d is this distance, the magnitude of the couple is Pd . This measures the rotating power.

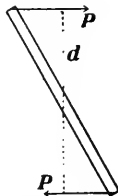

FIG. 41.—Two equal opposite parallel forces produce only rotation.

Next suppose there are two unlike parallel forces P, Q and

that Q is greater than P . Then the forces P and Q are equivalent to a couple tending to cause a rotation in the direction in which the hands of a clock turn, and to a force tending to produce a motion of translation in the direction of Q , that is, to the left hand (Fig. 42).

This can be seen in the following way. Divide Q into two forces P and $Q - P$. The portion P , along with P acting at the other end of the rod forms a couple, while the force $Q - P$ will give a motion of translation to the body in its direction.



FIG. 42.—Two opposite parallel but unequal forces produce both rotation and translation.

55. Experimental Verification of the Parallelogram Law.

By means of an experiment we can test the truth of the law of the Parallelogram of Forces, which states that if two forces are represented in magnitude and direction by two sides of a parallelogram, then their resultant will be represented, in magnitude and direction, by the diagonal between the two sides.

In Fig. 43, S, S' are two spring balances hung on pins in the bar AB , which may conveniently be above the blackboard. Three

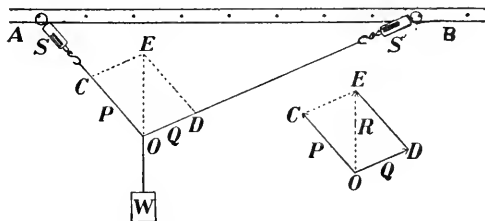

FIG. 43.—How to test the law of parallelogram of forces.

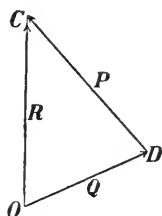

FIG. 44.—The triangle of forces.

strings of unequal length are knotted together at O , and the ends of two of them are fastened to the hooks of the balances. A weight, W ounces, attached to the third string makes it hang vertically downward.

Thus three forces, namely, the tensions of the strings, pull on the knot O . The magnitude of the forces acting along the strings, OS, OS' , which we shall denote by P, Q , will be given by the readings on the balances, in ounces, let us suppose. The magnitude of the force acting along OW is, of course, W ounces.

The three forces P , Q , W act upon the knot O , and as it does not move, these forces must be in equilibrium. The force W may be looked upon as balancing the other forces P , Q ; and hence the resultant of P , Q must be equal in magnitude to W but opposite in sense.

Draw now on the blackboard, immediately behind the apparatus or in some other convenient place, lines parallel to the strings OS , OS' , and make OC , OD as many units long as there are ounces shown on S , S' , respectively.

On completing the parallelogram $OCED$ it will be found that the diagonal OE is vertical, and that it is as many units long as there are ounces in W .

56. The Triangle of Forces. A slight variation will illustrate the triangle of forces.

On the blackboard, or on a sheet of paper, draw a line OD , parallel to OS' , to represent the force Q (Fig. 44). From D draw DC parallel to OS and representing P on the same scale. Then OC will be found to be parallel to OW , and will represent, on the same scale, the force W , but in the opposite sense.

57. The Polygon of Forces. Next let five strings be knotted together or attached to a small ring, and passed over pulleys at

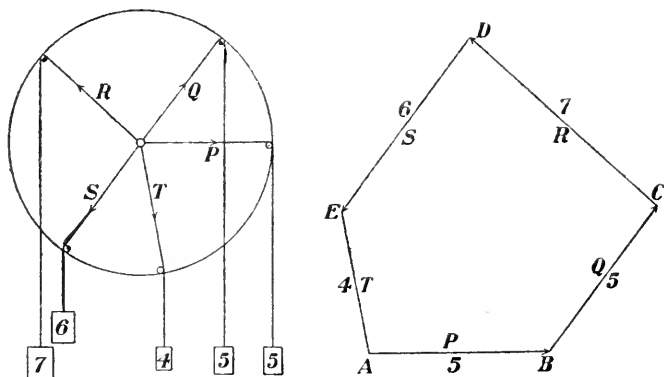

FIG. 45.—Experimental verification of the polygon of forces.

the edge of a circular board held vertically. To these attach weights P , Q , R , S , T . In Fig. 45 these are taken to be 5, 5, 7, 6, 4 ounces, respectively.

Since these forces are in equilibrium we may look upon the force T as balancing the other four forces; and hence the resultant of P, Q, R, S is a force equal to T but acting in the opposite direction.

On the blackboard draw a line AB to represent P in magnitude and direction. From B draw BC to represent Q , from C draw CD to represent R , and from D draw DE to represent S .

If the figure has been carefully drawn it will be found that the line joining E to A is parallel to T and proportional to it.

Thus if a number of forces acting on a particle are in equilibrium, they can be represented in magnitude and direction by the sides of a polygon taken in order.

CHAPTER V

GRAVITATION

58. The Law of Gravitation. One of our earliest and most familiar observations is that a body which is not supported falls towards the earth. This effect we attribute to the *attraction of the earth*.

The rates at which bodies move whilst falling were discovered by Galileo (1564-1642), but the general principle according to which the falling takes place was first demonstrated by Newton.

Copernicus (1473-1543) had shown that the sun is the centre of our solar system, but it was Newton who gave a reason why the various bodies of the system move as they do. He showed that if we suppose the sun, the planets and their satellites to attract each other according to a simple law, now usually known as the Newtonian Law, he could account not only for the revolution of the planets about the sun and the satellites about the planets, but also for some minute irregularities which on close examination are found to exist in their motions.

Having found his Law true for the heavenly bodies, he went one step further and extended it to all matter.

59. The Newtonian Law. Let m , m' be the masses of two particles of matter, r the distance between them. Then Newton's Law of Universal Gravitation states that the attraction between m and m' is proportional directly to the product of their masses and inversely to the square of the distance between them.

Thus the Force is proportional to $\frac{mm'}{r^2}$,

$$\text{or } F = k \frac{mm'}{r^2},$$

where k is a numerical constant.

If m , m' are small spheres, each containing 1 gram of matter and r , the distance between their centres, is 1 centimetre, then $F = 0.0000000648$ dynes. This is an exceedingly small quantity, and thus we see that between ordinary masses of matter the attractions are very small. Indeed it is only by means of experiments made with the utmost care and delicacy that the attraction between bodies which we can ordinarily handle can be detected.

It is to be remarked that though the Newtonian Law states the manner in which masses behave towards each other, it does not offer any explanation of the action. The *reason why* the attraction takes place is one of the mysteries of nature.

60. The Weight of a Body. Consider a mass m at A on the earth's surface (Fig. 46). The attraction of the earth on the mass is the *weight* of the mass. The mass also attracts the earth with an equal force, since action and reaction are equal.

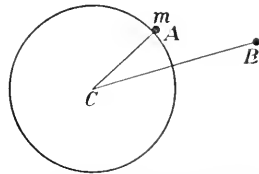

FIG. 46.—Attraction of the earth on a mass on its surface and also twice as far away from the centre.

If m is a pound-mass, the attraction of the earth on it is a *pound-force*; if it is a gram-mass, the attraction is a *gram-force*.

Now it can be shown by mathematical calculation that a homogeneous sphere attracts as though all the matter in it were concentrated at its centre. We see then that if the whole mass of the earth were condensed into a particle at C and a pound-mass were placed 4000 miles from it the attraction between the two would be 1 pound-force.

Next, suppose the pound-mass to be placed at B , 8000 miles from C . Then the force is not $\frac{1}{2}$ but $\frac{1}{2}$ or $\frac{1}{4}$ of its former value; that is, the *weight* of a pound mass 4000 miles above the earth's surface would be $\frac{1}{4}$ of a pound-force.

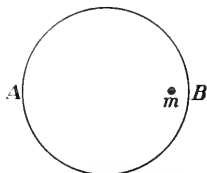

FIG. 47.—Attraction of the sphere on a mass within it.

If it were 2000 miles from the earth's surface or 6000 miles from its centre, this distance is $\frac{6000}{4000}$ or $\frac{3}{2}$ of its former distance, and the force of attraction

$$= \frac{1}{\left(\frac{3}{2}\right)^2} = \frac{4}{9} \text{ of 1 pound-force.}$$

61. Attraction within the Sphere. Let AB be a homogeneous shell (like a hollow rubber ball) and m a mass within it. It can be shown that the attraction of the shell in any direction on m is zero. The "pull" exerted by the portion at the side B is just balanced by that at the side A .

Now let us suppose the pound-mass to be some distance—say, 2000 miles—below the earth's surface (Fig. 48), and we wish to find the attraction towards the centre. Consider the earth divided into two parts, a sphere 2000 miles in radius, and a shell outside this 2000 miles thick. From what has just been said, the attraction of the shell on the pound-mass is zero, and so we need only find the attraction of the inner sphere.

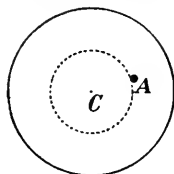

FIG. 48.—Attraction on a mass half-way to the earth's centre is one half the attraction at the surface.

Let us assume that the density of the earth is uniform. Then since the radius of the inner sphere is $\frac{1}{2}$ the earth's radius, its volume and also its mass is $\frac{1}{8}$ that of the earth.

Hence if the mass only were considered the attraction would be $\frac{1}{8}$ pound-force.

But the distance also is changed. It is now $\frac{1}{2}$ as great and the attraction on that account should be increased 2^2 or 4 times.

Hence, taking both of these factors into account, we find that the attraction towards the centre upon the pound-mass

$$= 4 \times \frac{1}{8} = \frac{1}{2} \text{ pound-force.}$$

Thus, on going down half-way to the centre, the attraction is $\frac{1}{2}$ as great. If the distance were $\frac{1}{4}$ the distance from the centre, the attraction on the pound-mass would be $\frac{1}{4}$ pound-force; and so on.

62. Attraction on the Moon. Let us calculate the weight of a pound-mass on the surface of the moon.

The moon's diameter is 2163 miles and the earth's is 7918 miles, but for ease in calculation we shall take these numbers as 2000 and 8000 respectively.

Assuming, then, the radius of the moon to be $\frac{1}{4}$ that of the earth, its volume is $\frac{1}{64}$ that of the earth, and if the two bodies were equally dense the moon's mass would also be $\frac{1}{64}$.

In this case the attraction on a pound-mass at a distance of 4000 miles from its centre would be $\frac{1}{64}$ of a pound force.

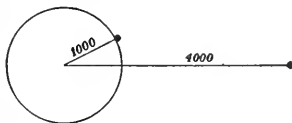

FIG. 49.—Attraction on the moon is one-sixth that on the earth.

But the distance is 1000 miles, or $\frac{1}{4}$ of this, and the attraction on this account would be 4^2 or 16 times as great.

Hence, attraction = $16 \times \frac{1}{64} = \frac{1}{4}$ pound-force.

But the density of the moon is only $\frac{6}{10}$ that of the earth; and so the attraction

$$= \frac{6}{10} \times \frac{1}{4} = \frac{6}{40} = \frac{3}{20} \text{ approximately.}^*$$

Hence if we could visit the moon, retaining our muscular strength, we would lift 600 pounds with the same ease that we lift 100 on the earth. If you can throw a base-ball 100 yards here, you could throw it 600 there.

On the surface of the sun, so immense is that body, the weight of a pound-mass is 27 pounds-force.

QUESTIONS AND PROBLEMS

1. If the earth's mass were doubled without any change in its dimensions, how would the weight of a pound-mass vary?

Could one use ordinary balances and the same weights as we use now?

2. Find the weight of a body of mass 100 kilograms at 6000, 8000, 10,000 miles from the earth's centre.

3. The diameter of the planet Mars is 4230 miles and its density is $\frac{7}{10}$ that of the earth. Find the weight of a pound-mass on the surface of Mars.

4. The attraction of the earth on a mass at one of its poles is $\frac{1}{512}$ greater than at the equator. Why is this?

5. A spring-balance would have to be used to compare the weight of a body on the sun or the moon with that on the earth. Explain why.

* A more accurate calculation is

$$\left(\frac{2163}{7918}\right)^3 \times \left(\frac{7918}{2163}\right)^2 \times \frac{6}{10} = \frac{6489}{39590} = \frac{1}{6.101}$$

CHAPTER VI

WORK AND ENERGY

63. Definition of Work. When one draws water from a cistern by means of a bucket on the end of a rope; or when bricks are hoisted during the erection of a building; or when land is ploughed up; or when a blacksmith files a piece of iron; or when a carpenter planes a board; it is recognized that *work* is done.

We recognize, too, that the amount of the work done depends on two factors:—

(1) The amount of water in the bucket, or the number of bricks lifted, or the force exerted to draw the plough, push the file or drive the plane.

(2) The distance through which the water or bricks are lifted or the plough, file or plane is moved.

In every instance it will be observed that a force acts on a body and causes it to move. In the cases of the water and the bricks the forces exerted are sufficient to lift them, *i.e.*, to overcome the attraction of the earth upon them; in the other cases, sufficient force is exerted to cause the plough or the file or the plane to move.

In physics the term **WORK** denotes *the quantity obtained when we multiply the force by the distance in the direction of the force through which it acts.*

In order to do work, force must be exerted on a body and the body must move in the direction in which the force acts.

64. Units of Work. By choosing various units of force and of length we obtain different units of work.

If we take as unit of force a pound-force and as unit of length a foot, the unit of work will be a foot-pound.

If 2000 pounds mass is raised through 40 feet the work done is $2000 \times 40 = 80,000$ foot-pounds.

In the same way, a kilogram-metre is the work done in raising a kilogram through a metre.

If we take a centimetre as unit of length and a dyne as unit of force the unit of work is a dyne-centimetre. To this has been given a special name, *erg*.

Now 1 gram-force = g dynes ; (§ 46)

Hence 1 gram-centimetre = g ergs.

To raise 20 grams through 30 cm. the work required is $20 \times 30 = 600$ gram-centimetres = $600 g$ ergs = 600×980 or 588,000 ergs.

65. How to Calculate Work. A bag of flour, 98 pounds, has to be carried from the foot to the top of a cliff, which has a vertical face and is 100 feet high.

There are three paths from the base to the summit of the cliff. The first is by way of a vertical ladder fastened to the face of the cliff. The second is a zig-zag path 300 feet long, and the third is also a zig-zag route, 700 feet long.

Here a person might strap the mass to be carried to his back and climb vertically up the ladder, or take either of the other two routes. The distances passed through are 100 feet, 300 feet, 700 feet, respectively, but the result is the same in the end, the mass is raised through 100 feet.

The force required to lift the mass is 98 pounds-force, and it acts in the vertical direction. The distance *in this direction* through which the body is moved is 100 feet, and therefore the

$$\text{Work} = 98 \times 100 = 9800 \text{ foot-pounds.}$$

Along the zig-zag paths the effort required to carry the mass is not so great, but the length of path is greater and so the total work is the same in the end.

PROBLEMS

1. Find the work done in exerting a force of 1000 dynes through a space of 1 metre.
2. A block of stone rests on a horizontal pavement. A spring balance, inserted in a rope attached to it, shows that to drag the stone requires a force of 90 pounds. If it is dragged through 20 feet, what is the work done?
3. The weight of a pile-driver, of 2500 pounds mass, was raised through 20 feet. How much work was required?
4. A coil-spring, naturally 30 centimetres long, is compressed until it is 10 centimetres long, the average force exerted being 20,000 dynes. Find the work done. Find its value in kilogram-metres ($g = 980$).
5. Two men are cutting logs with a cross-cut saw. To move the saw requires a force of 50 pounds, and 50 strokes are made per minute, the length of each being 2 feet. Find the amount of work done by each man in one hour.
6. To push his cart a banana man must exert a force of 50 pounds. How much work does he do in travelling 2 miles?

66. Definition of Energy. A log, known as a pile, the lower end of which is pointed, stands upright, and it is desired to push it into the earth. To do so requires a great force, and therefore the performance of great work.

The method of doing it is familiar to all. A heavy block of iron is raised to a considerable height and allowed to fall upon the top of the log, which is thus pushed downwards. Successive blows drive the pile further and further into the earth, until it is down far enough.

Here work is done in thrusting the pile into its place, and this work is supplied by the pile-driver weight. It is evident then, that a heavy body raised to a height is able to do work.

Ability to do work is called ENERGY.

The iron block in its elevated position has energy. As it descends it gives up this high position, and acquires velocity. Just before striking the pile it has a great velocity, and this velocity is used up in pushing the pile into the earth. It is clear, then, that a body in motion possesses energy.

We see, thus, that there are two kinds of energy :

- (1) Energy of position or *potential* energy.
- (2) Energy of motion or *kinetic* energy.

67. Transformations of Energy. Energy may appear in different forms, but if closely analysed it will be found that it is always either energy of position, *i.e.*, potential energy, or energy of motion, *i.e.*, kinetic energy.

The various effects due to heat, light, sound and electricity are manifestations of energy, and one of the greatest achievements of modern science was the demonstration of the Principle of the Conservation of Energy. According to this doctrine, *the sum total of the energy in the universe remains the same.* It may change from one form to another, but none of it is ever destroyed.

A pendulum illustrates well the transformation of energy. At the highest point of its swing the energy is entirely potential, and as it falls it gradually gives up this, until at its lowest position the energy is entirely kinetic.

68. The Measure of Kinetic Energy. Suppose a mass m grams to be lifted through a height h centimetres. (Fig. 50.)

The force required is m grams force or mg dynes, and hence the work done is mgh ergs.

Suppose now the mass is allowed to fall. Upon reaching the level A it will have fallen through a space h , and it will have a velocity v such that

$$v^2 = 2gh. \quad (\S 31.)$$

The potential energy possessed by the body when at B is mgh ergs, and as this energy of position is changed into energy of motion, its kinetic energy on reaching A must also be mgh ergs.

But $gh = \frac{1}{2}v^2$
and so the kinetic energy = $\frac{1}{2}mv^2$ ergs.

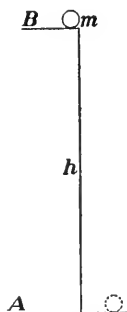

FIG. 50.—The potential energy at height B is equal to the kinetic energy on reaching A .

Hence a mass m grams moving with a velocity v cm. per second has kinetic energy $\frac{1}{2}mv^2$ ergs.

If the mass is m lbs. and the velocity v ft. per sec., the kinetic energy = $\frac{1}{2}mv^2$ ft.-poundals = $\frac{1}{2}\frac{mv^2}{g}$ ft.-pounds, since 1 pound-force = g poundals, where $g = 32$. (See § 46.)

69. More General Solution. This result can be obtained in a somewhat more general way.

Let a force F dynes act for t seconds on a mass m grams initially at rest.

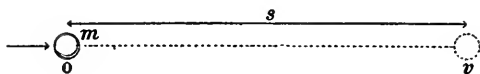

FIG. 51.—The calculation of kinetic energy.

Let the velocity produced be v cm. per sec., and the space traversed be s cm.

The force F dynes acts through a space s cm., and so does Fs ergs of work. The body then at the end of the time possesses Fs ergs of energy.

But its velocity = v cm. per sec.

Since, now, the velocity at first = 0, and at the end = v , the average velocity = $\frac{1}{2}v$ cm. per sec.; and in time t seconds the space traversed,

$$s = \frac{1}{2}vt \text{ centimetres.}$$

Also, the force F dynes acting for t seconds generates Ft units of momentum. But the momentum = mv .

$$\text{Therefore } Ft = mv, \quad (\text{See §§ 43, 44})$$

$$\text{and } F = \frac{mv}{t}.$$

But the kinetic energy = Fs ,

$$= \frac{mv}{t} \times \frac{1}{2}vt,$$

$$= \frac{1}{2}mv^2 \text{ ergs.}$$

70. Matter, Energy, Force. There are two fundamental propositions in science:—Matter cannot be destroyed, energy cannot be destroyed. The former lies at the basis of

analytical chemistry; the latter at the basis of physics. It is to be observed, also, that matter is the vehicle or receptacle of energy.

Force, on the other hand, is of an entirely different nature. On pulling a string a tension is exerted in it, which disappears when we let it go. Energy is bought and sold, force cannot be.

Again consider the formula $s = vt$. Writing it thus, $v = \frac{s}{t}$, we say that velocity is the time-rate of traversing space.

$$\begin{aligned} \text{Similarly Work} &= \text{Force} \times \text{Space}, \\ \text{or } W &= Fs. \end{aligned}$$

Writing this formula thus, $F = \frac{W}{s}$, we can say that force is the space-rate of change of energy.

71. Power. The *power* or *activity* of an agent is its rate of doing work.

A horse-power (*H.-P.*) is that rate of doing work which would accomplish 33,000 foot-pounds of work per minute, or 550 foot-pounds per second.

In the centimetre-gram-second system the unit of power would naturally be 1 erg per second.

But this is an extremely small quantity, and instead of it we use 1 watt which is defined thus:

$$1 \text{ watt} = 10,000,000 \text{ ergs per second.}$$

It is found that

$$746 \text{ watts} = 1 \text{ H.-P.}$$

and if 1 kilowatt = 1000 watts, then

$$\frac{746}{1000} \text{ K.W.} = 1 \text{ H.-P.}$$

CHAPTER VII

CENTRE OF GRAVITY

72. Definition of Centre of Gravity. Each particle of a body is acted on by the force of gravitation. The line of action of each little force is towards the centre of the earth, and hence, strictly speaking, they are not absolutely parallel. But the angles between them are so very small that we usually speak of the weights of the various particles as a set of parallel forces.

These forces have a single resultant, as can be seen in the following way.

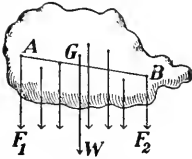

FIG. 52.—The weight of a body acts at its centre of gravity.

Consider two forces F_1, F_2 , acting at A, B , respectively (Fig. 52). These will have a resultant acting somewhere in the line AB which joins the points of application.

Next, take this resultant and another force; they will have a single resultant.

Continuing in this way, we at last come to the resultant of all, acting at some definite point.

The sum of all these forces is the weight of the body, and the point G where the weight acts is called the **CENTRE OF GRAVITY** of the body. If the body be supported at this point it will rest in equilibrium in any position, that is, if the body is put in any position it will keep it.

73. To find the Centre of Gravity Experimentally. Suspend the body by a cord attached to any point A of it.

Then the weight acting at G and the tension of the string acting upwards at A will rotate the body until the point G comes directly beneath A , and the line GW is coincident with the direction of the supporting cord (Fig. 53).

Thus if the body is suspended at A , and allowed to come to rest, the direction of the supporting cord will pass through the centre of gravity.

Next let the body be supported at B . The direction of the supporting cord will again pass through the centre of gravity. That point is, therefore, where the two lines meet.

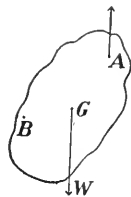

FIG. 53.—How to find the centre of gravity of a body of any form.

In the case of a flat body, such as a sheet of metal or a thin board, let it be supported at A (Fig. 54*a*) by a pin or in some other convenient way. Have a cord attached to A with a small weight on the end of it.



FIG. 54*a*

How to find the centre of gravity of a flat body.

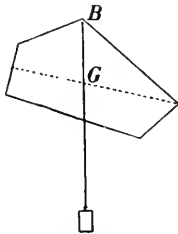

FIG. 54*b*

How to find the centre of gravity of a flat body.

Chalk the cord and then snap it on the plate: it will make a white line across it.

Next, support the body from B (Fig. 54*b*) and obtain another chalk line. At G , the point of intersection of these two lines, is the centre of gravity.

74. Centre of Gravity of some Bodies of Simple Form.

The centre of gravity of some bodies of simple form can often be deduced from geometrical considerations.

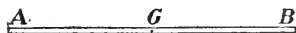

FIG. 55.—Centre of gravity of a uniform rod

(1) For a straight uniform bar AB (Fig. 55), the centre of gravity is midway between the ends.

(2) For a parallelogram, it is at the intersection of the diagonals. (Fig. 56.)

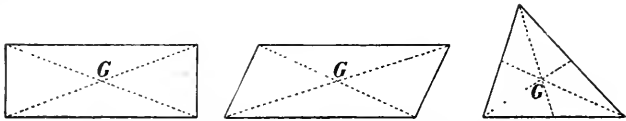

FIG. 56.—Centre of gravity of a parallelogram and a triangle.

(3) For a cube or a sphere, it is at the centre of figure.

(4) For a triangle, it is where the three median lines intersect. (Fig. 56.)

75. Condition for Equilibrium. For a body to rest in equilibrium on a plane, the line of action of the weight must fall within

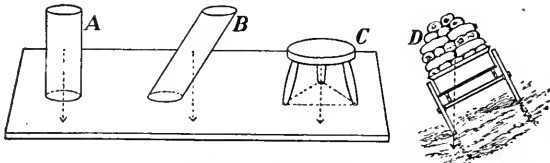

FIG. 57.—A and C are in stable equilibrium; B is not, it will topple over; D is in the critical position.

the supporting base, which is the space within a cord drawn about the points of support. (See Fig. 57.)

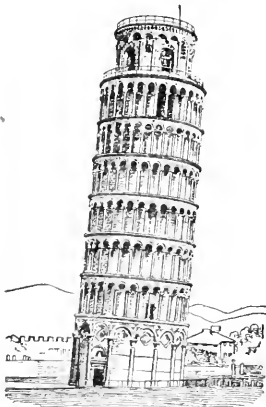

FIG. 58.—The Leaning Tower of Pisa. It overhangs its base more than 13 feet, but it is stable. (Drawn from a photograph.)

The famous Leaning Tower of Pisa is an interesting case of stability of equilibrium. It is circular in plan, 51 feet in diameter and 172 feet high, and has eight stages, including the belfry. Its construction was begun in 1174. It was founded on wooden piles driven in boggy ground, and when it had been carried up 35 feet it began to settle to one side. The tower overhangs the base upwards of 13 feet, but the centre of gravity is so low down that a vertical through it falls within the base and hence the equilibrium is stable.

76. The three States of Equilibrium. The centre of gravity of a body will always descend to as low a position as possible, or the potential energy of a body tends to become a minimum.

Consider a body in equilibrium, and suppose that by a slight motion this equilibrium is disturbed. Then if the body tends to return to its former position, its equilibrium is said to be *stable*. In this case the slight motion raises the centre of gravity, and on letting it go the body tends to return to its original position.

If, however, a slight disturbance lowers the centre of gravity the body will not return to its original position, but will take up a new position in which the centre of gravity is lower than before. In this case the equilibrium is said to be *unstable*.

Sometimes a body rests equally well in any position in which it may be placed, in which case the equilibrium is said to be *neutral*.

An egg standing on end is in unstable equilibrium; if resting on its side the equilibrium is stable as regards motion in an oval section and neutral as regards motion in a circular section. A uniform sphere rests anywhere it is placed on a level surface; its equilibrium is neutral. (Fig. 59.)

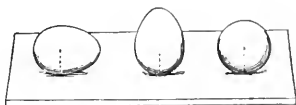

Fig. 59.—Stable, unstable and neutral equilibrium.

A round pencil lying on its side is in neutral equilibrium; balanced on its end, it is unstable. A cube, or a brick, lying on a face, is stable.

The amount of stability possessed by a body resting on a horizontal plane varies in different cases. It increases with the distance through which the centre of gravity has to be raised in order to make the body tip over. Thus, a brick lying on its largest face is more stable than when lying on its smallest.

QUESTIONS AND PROBLEMS

1. Why is a pyramid a very stable structure?
2. Why is ballast used in a vessel? Where should it be put?
3. Why should a passenger in a canoe sit on the bottom?
4. A pencil will not stand on its point, but if two pen-knives are fastened to it (Fig. 60) it will balance on one's finger. Explain why this is so.
5. A uniform iron bar weighs 4 pounds per foot of its length. A weight of 5 pounds is hung from one end, and the rod balances about a point which is 2 feet from that end. Find the length of the bar.

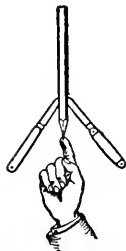

Fig. 60.—Why is the pencil in equilibrium?

6. Illustrate the three states of equilibrium by a cone lying on a horizontal table.

CHAPTER VIII

FRICTION

77. Friction Stops Motion. A stone thrown along the ice will, if "left to itself," come to rest. A railway-train on a level track, or an ocean steamboat will, if the steam is shut off, in time come to rest. Here much energy of motion disappears and no gain of energy of position takes its place. In the same way all the machinery of a factory when the "power" is turned off soon comes to rest.

In all these cases the energy simply seems to disappear and be *wasted*. As we shall see later, it is transformed into energy of another form, namely, heat, but it is done in such a way that we cannot utilize it.

The stopping of the motion in every instance given is due to *friction*. When one body slides or rolls over another there is always friction, which acts as a force in opposition to the motion.

It may be observed, however, that if there were not friction between the rails and the wheels of the locomotive, the latter could not start to move.

78. Every Surface is Rough. The smoothest surface, when examined with a powerful microscope,

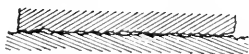

FIG. 61.—Roughness of a surface as seen under a microscope.

is seen to have numerous little projections and cavities on it (Fig. 61), Hence when two surfaces are pressed together there is a kind of interlocking of these irregularities which resists the motion of one over the other.

79. Laws of Sliding Friction. Friction depends upon the nature of the substances and the roughness of the surfaces in contact; and as it is impossible to avoid irregularities in surfaces, accurate experiments to determine the laws of friction are very difficult. By means of the apparatus shown in Fig. 62, the laws of sliding friction can be investigated.

M is a flat block resting on a plane surface. A cord is attached to it and passes over a pulley. On the end of the cord is a pan holding weights.

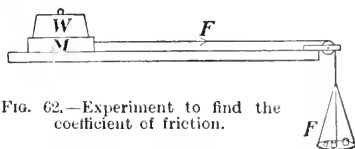

Fig. 62.—Experiment to find the coefficient of friction.

Let the entire weight on the pan be F' ; then the tension of the cord, which is the force tending to move the block M , is equal to F' .

Now let F' be increased until the block M moves uniformly over the surface. The friction developed just balances the force F' . If F' were greater than the friction it would give an acceleration to M .

Suppose that the weight on the block is doubled. In order to give a uniform motion to M we shall have to add double the weight to the pan.

Thus the ratio F'/W is constant; it is called the *coefficient of friction* between the block M and the surface.

For dry pine, smooth surfaces, the coefficient is about 0.25, *i.e.*, a 40-pound block would require a 10-pound force to drag it over a horizontal pine surface.

For iron on iron, smooth but not oiled, the coefficient is about 0.2; if oiled, about 0.07. This shows the use of oil as a lubricant.

The following laws have been established by experiment:

- (1) Friction varies directly as the pressure between the surfaces in contact.
- (2) Friction is independent of the extent of the surfaces.
- (3) Friction is independent of the rate of motion.
- (4) The friction at the instant of starting is greater than in a state of uniform motion.

80. Rolling Friction. When a wheel or a sphere rolls on a plane surface the resistance to the motion produced at the point of contact is said to be due to *rolling* friction. This, however, is very different from the friction just discussed, as there is no sliding. It is also very much smaller in magnitude.

After a rain, when some rust has formed on the rails, the power required to draw a train over them is considerably greater than when they are dry and smooth, since the coefficient of friction is higher.

In ordinary wheels, however, sliding friction is not avoided. In the case of the hub of a carriage (Fig. 63) there is sliding friction at the point *C*.

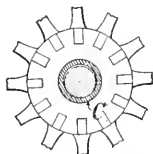

Fig. 63. — Section through a carriage hub, showing an ordinary bearing.

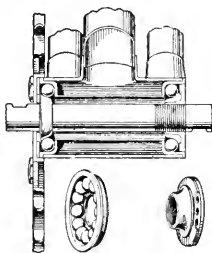

Fig. 64. — Section of the crank of a bicycle. The cup which holds the balls and the cone on which they run are shown separately below. Here the balls touch the cup in two points and the cone in one; it is a "three-point" bearing.

In ball-bearings (Fig. 64), which are much used in bicycles, automobiles and other high-class bearings, the sliding friction is almost completely replaced by rolling friction, and hence this kind of bearing has great advantages over the other.

QUESTIONS AND PROBLEMS

1. Explain the utility of friction in
 - (a) Locomotive wheels on a railway track.
 - (b) Leather belts for transmitting power.
 - (c) Brakes to stop a moving car.
2. The current of a river is less rapid near its banks than in mid-stream. Can you explain this?
3. What horizontal force is required to drag a trunk weighing 150 pounds across a floor, if the coefficient of friction between trunk and floor is 0.3?
4. Give two reasons why it is more difficult to start a heavily-laden cart than to keep it in motion after it has started.
5. A brick, 2 x 4 x 8 inches in size, is slid over ice. Will the distance it moves depend on what face it rests upon?

CHAPTER IX

MACHINES

81. Object of a Machine. A machine is a device by which energy is transferred from one place to another, or is transformed from one kind to another.

The six simplest machines, usually known as the *mechanical powers* are, the lever, the pulley, the wheel and axle, the inclined plane, the wedge and the screw. All other machines, no matter how complicated, are but combinations of these.

Since energy cannot be created or destroyed, but simply changed from one form to another, it is evident that, neglecting friction, the amount of work put into a machine is equal to the amount which it will deliver.

82. The Lever; First Class. The lever is a rigid rod movable about a fixed axis called the fulcrum. Levers are of three classes.

First Class. In Fig. 65 AB is a rigid rod which can turn

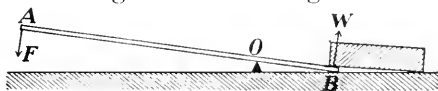

FIG. 65.—Lever of the first class.

about O , the fulcrum. By applying a force F at A a force W is exerted at B against a heavy body, which it is desired to raise.

AO , BO are called the *arms* of the lever.

Then by the principle of moments, the moment of the force F about O is equal to the moment of the force W about O , that is,

$$F \times AO = W \times BO,$$

$$\text{or} \quad \frac{W}{F} = \frac{AO}{BO}$$

$$\text{or} \quad \frac{\text{Force obtained}}{\text{Force applied}} = \text{Inverse ratio of lengths of arms.}$$

This is called the *Law of the Lever*, and the ratio W/F is called the mechanical advantage.

Suppose, for instance, $AO = 36$ inches, $BO = 4$ inches.

Then $\frac{W}{F} = \frac{AO}{BO} = \frac{36}{4} = 9$, the mechanical advantage.

There are many examples of levers of the first class. Among them are, the common balance, a pump handle, a pair of scissors (Fig. 66), a claw-hammer (Fig 67).

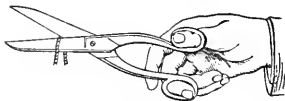

FIG. 66.—Scissors, lever of the first class.

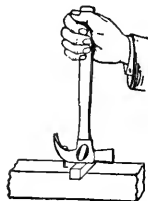

FIG. 67.—Claw-hammer, used as a lever of the first class.

The law of the lever can be obtained by applying the principle of energy.

Suppose the end A (Fig. 68) to move through a distance a

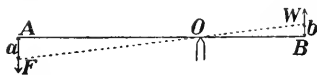

FIG. 68.

and the end B through a distance b . It is evident that

$$\frac{a}{b} = \frac{AO}{BO}.$$

Now the work done by the force F , acting through a distance a is $F \times a$, while the work done by W acting through a distance b is $W \times b$.

Neglecting all considerations of friction or of the weight of the lever, the work done by the applied force F must be equal to the work accomplished by the force W .

Hence $Fa = Wb$,

and the mechanical advantage $\frac{W}{F} = \frac{a}{b} = \frac{AO}{BO}$,

which is the law of the lever.

83. The Lever; Second Class. In levers of the second class the weight to be lifted is placed between the point where the force is applied and the fulcrum.

As before, the force F is applied at A (Fig. 69), but the force produced is exerted at B , between A and the fulcrum O .

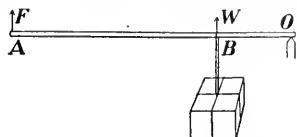

FIG. 69.—Lever of the second class.

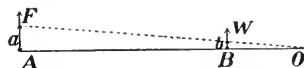

FIG. 70.—Theory of the lever of the second class.

Here we have, by the principle of moments,

$$F \times AO = W \times BO,$$

and the mechanical advantage $\frac{W}{F} = \frac{AO}{BO}$, which in levers of this class is always greater than 1.

Or, by applying the principle of energy (Fig. 70), work done by F is Fa , by W is Wb .

$$\text{Hence } Fa = Wb,$$

$$\text{or } \frac{W}{F} = \frac{a}{b} = \frac{AO}{BO}, \text{ the law of the lever.}$$

Examples of levers of the second class: nut-crackers (Fig. 71), trimming board (Fig. 72), safety-valve (Fig. 73), wheelbarrow, oar of a row-boat.

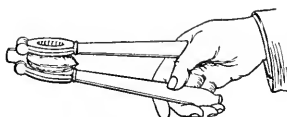

FIG. 71.—Nut-crackers, lever of the second class.

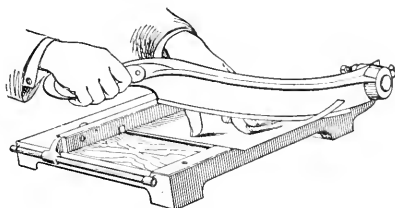

FIG. 72.—Trimming board for cutting paper or cardboard; lever of the second class.

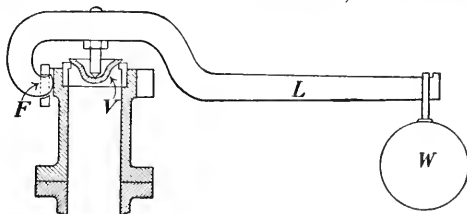

FIG. 73.—A safety-valve of a steam boiler. (Lever of the second class.) L is the lever arm, V the valve on which the pressure is exerted, W the weight which is lifted, F the fulcrum.

84.—**The Lever; Third Class.** In this case the force F is applied between the fulcrum and the weight to be lifted. (Fig. 74.)



FIG. 74.—A lever of the third class.

As before, we have

$$F \times AO = W \times BO,$$

or $\frac{W}{F} = \frac{AO}{BO}$, the law of the lever.

Notice that the weight lifted is always less than the force applied, or the mechanical advantage is less than 1.

Examples of levers of this class: sugar-tongs (Fig. 75), the human forearm (Fig. 76); treadle of a lathe or a sewing machine.

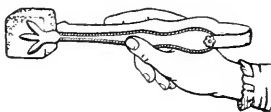

FIG. 75.—Sugar-tongs, lever of the third class.

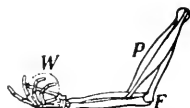

FIG. 76.—Human forearm, lever of the third class. One end of the biceps muscle is attached at the shoulder, the other is attached to the radial bone near the elbow, and exerts a force to raise the weight in the hand.

PROBLEMS

1. Explain the action of the steelyards (Fig. 77). To which class of levers does it belong? If the distance from B to O is $1\frac{1}{2}$ inches, and the sliding weight P when at a distance 6 inches from O balances a mass of 5 lb. on the hook, what must be the weight of P ?

If the mass on the hook is too great to be balanced by P , what additional attachment would be required in order to weigh it?

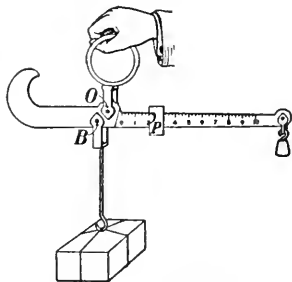

FIG. 77.—The steelyards.

2. A hand-barrow (Fig. 78), with the mass loaded on it weighs 210 pounds. The centre of gravity of the barrow and load is 4 feet from the front handles and 3 feet from the back ones. Find the amount each man carries

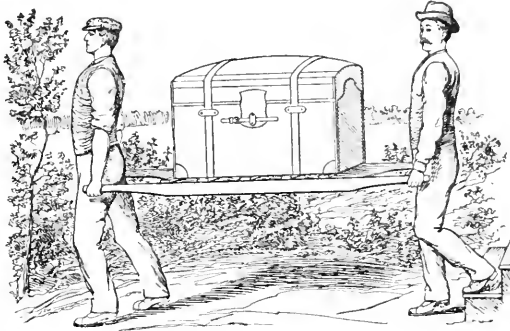

FIG. 78.—The hand-barrow.

3. To draw a nail from a piece of wood requires a pull of 200 pounds. A claw-hammer is used, the nail being $1\frac{1}{2}$ inches from the fulcrum O (Fig. 67) and the hand being

8 inches from O . Find what force the hand must exert to draw the nail.

4. A cubical block of granite, whose edge is 3 feet in length and which weighs 4500 lbs., is raised by thrusting one end of a crowbar 40 inches long under it to the distance of 4 inches, and then lifting on the other end. What force must be exerted?

85. The Pulley. The pulley is used sometimes to change the direction in which a force acts, sometimes to gain mechanical advantage, and sometimes for both purposes. We shall neglect the weight and friction of the pulley and the rope.

A single fixed pulley, such as is shown in Fig. 79, can change the direction of a force but cannot give a mechanical advantage greater than 1. F , the force applied, is equal to the weight lifted, W .

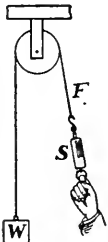

FIG. 79.—A fixed pulley simply changes the direction of force.

By this arrangement a lift is changed into a pull in any convenient direction. It is often used in raising materials during the construction of a building.

By inserting a spring balance, S , in the rope, between the hand and the pulley, one can show that the force F is equal to the weight W .

Suppose the hand to move through a distance a , then the weight rises through the same distance.

$$\begin{aligned} \text{Hence } F \times a &= W \times a \\ \text{or } F &= W, \end{aligned}$$

as tested by the spring balance.

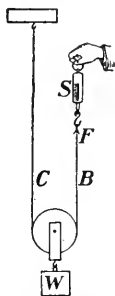

FIG. 80.—With a movable pulley the force exerted is only half as great as the weight lifted.

86. A Single Movable Pulley. Here the weight W (Fig. 80) is supported by the two portions, B and C , of the rope, and hence each portion supports half of it.

Thus the force F is equal to $\frac{1}{2} W$, and the mechanical advantage is 2.

This result can also be obtained from the principle of energy.

Let a be the distance through which W rises. Then each portion, B and C , of the rope will be shortened a distance a , and so F will move through a distance $2a$.

Then, since

$$F \times 2a = W \times a$$

$$W/F = 2, \text{ the mechanical advantage.}$$

For convenience a fixed pulley also is generally used as in Fig. 81.

Here when the weight rises 1 inch, B and C each shorten 1 inch and hence A lengthens 2 inches. That is, F moves through twice as far as W , and $W/F = 2$, as before.

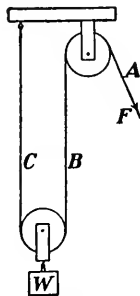

FIG. 81.—With a fixed and a movable pulley the force is changed in direction and reduced one-half.

87. Other Systems of Pulleys. Various combinations of pulleys may be used. Two are shown in Figs. 82, 83, the latter one being very commonly seen.

Here there are six portions of the rope supporting W , and hence the tension in each portion is $\frac{1}{6} W$.

Hence $F = \frac{1}{6} W$,

or a force equal to $\frac{1}{6} W$ will hold up W . This entirely neglects friction, which in such a system is often considerable, and it therefore follows that to prevent W from descending, less than $\frac{1}{6} W$ will be required. On the other hand, to actually lift W the force F must be greater than $\frac{1}{6} W$. In every case friction acts to prevent motion.

Let us apply the principle of energy to this case. If W rises 1 foot each portion of the rope supporting it must shorten 1 foot and the force F will move 6 feet.

Then, work done on $W = W \times 1$ foot-pounds

 " " by $F = F \times 6$ "

These are equal, and hence

$$W = 6 F$$

or $W/F = 6$, the mechanical advantage.

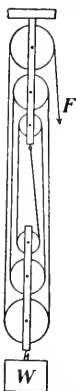

FIG. 82.—Combination of 6 pulleys; 6 times the force lifted.



FIG. 83.—A familiar combination for multiplying the force 6 times.

PROBLEMS

1. A clock may be driven in two ways. First, the weight may be attached to the end of the cord; or secondly, it may be attached to a pulley, movable as in Fig. 80, one end of the cord being fastened to the framework, and the other being wound about the barrel of the driving wheel. Compare the weights required, and also the length of time the clock will run in the two cases.

2. Find the mechanical advantage of the system shown in Fig. 84. This arrangement is called the Spanish Barton.

3. What fraction of his weight must the man shown in Fig. 85 exert in order to raise himself?



FIG. 84.—The Spanish Barton.

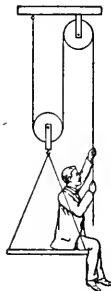

FIG. 85.—An easy method to raise one's self.



FIG. 86.—Find the pressure of the feet on the floor?

4. A man weighing 140 pounds pulls up a weight of 80 pounds by means of a fixed pulley, under which he stands (Fig. 86). Find his pressure on the floor.

88. The Wheel and Axle.

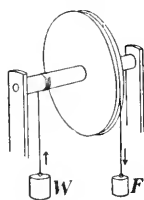

FIG. 87.—The wheel and axle.

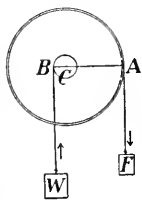

FIG. 88.—Diagram to explain the wheel and axle.

This machine is shown in Figs. 87, 88. It is evident that in one complete rotation the weight F will descend a distance equal to the circumference of the wheel, while the weight W will rise a distance equal to the circumference of the axle.

Hence $F \times$ circumference of wheel = $W \times$ circumference of axle. Let the radii be R and r , respectively; the circumferences will be $2\pi R$ and $2\pi r$, and therefore

$$F \times 2\pi R = W \times 2\pi r,$$

$$\text{or } FR = Wr,$$

$$\text{and } \frac{W}{F} = \frac{R}{r}, \text{ the mechanical advantage.}$$

This result can also be seen from Fig. 88. The wheel and axle turn about the centre C . Now W acts at B , a distance r from C , and F acts at A , a distance R from C .

Then, from the principle of the lever

$$F \times R = W \times r, \text{ as before.}$$

89. Examples of Wheel and Axle. The windlass (Fig. 89) is a common example, but, in place of a wheel, handles are used. Forces are applied at the handles and the bucket is lifted by the rope, which is wound about the axle.



Fig. 89.—Windlass used in drawing water from a well.

If F = applied force, and W = weight lifted, $\frac{W}{F} = \frac{\text{length of crank}}{\text{radius of axle}}$.

The capstan, used on board ships for raising the anchor, is another example (Fig. 90).

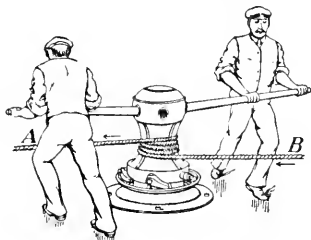

Fig. 90.—Raising the ship's anchor by a capstan.

The sailors apply the force by pushing against bars thrust into holes near the top of the capstan. Usually the rope is too long to be all coiled up on the barrel, so it is passed about it several times and the end A is held by a man who keeps that portion taut. The friction is sufficient to prevent

the rope from slipping. Sometimes the end B is fastened to a post or a ring on the dock, and by turning the capstan this portion is shortened and the ship is drawn into the dock.

90. Differential Wheel and Axle. This machine is shown in Fig. 91. It will be seen that the rope winds off one axle and on the other. Hence in one rotation of the crank the rope is lengthened (or shortened) by an amount equal to the difference in the circumferences of the two axles; but since the rope passes round a movable pulley, the weight to be lifted, attached to this pulley, will rise only one-half the difference in the circumferences.

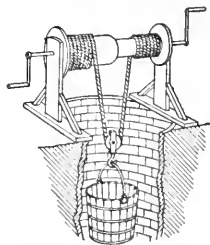

Fig. 91.—Differential wheel and axle.

Thus by making the two drums which form the axles nearly equal in size we can make the difference in their circumferences as small as we please, and the mechanical advantage will be as great as we desire.

91. Differential Pulley. This is somewhat similar to the last described machine. (Figs. 92, 93.)



FIG. 92.—Explanation of the action of the differential pulley.

Two pulleys, of different radii (Fig. 92), are fastened together and turn with the same angular velocity. Grooves are cut in the pulleys so as to receive an endless chain and prevent it from slipping.

Suppose the chain is pulled at F until the two pulleys have made a complete rotation. Then F will have moved through a distance equal to the circumference of A , and it will have done work

$$= F \times \text{circumference of } A.$$

Also, the chain between the upper and the lower pulley will be shortened by the circumference of A but lengthened by the circumference of B , and the net shortening is the difference between these two circumferences.

But the weight W will rise only half of this difference. Hence work done by W

$$= W \times \frac{1}{2} \text{ difference of circumferences of } A \text{ and } B,$$

and therefore $\frac{W}{F} = \frac{\text{circumference of } A}{\frac{1}{2} \text{ difference of circumferences of } A \text{ and } B}$.

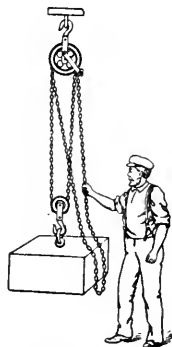

FIG. 93.—The actual appearance of the differential pulley.

PROBLEMS

1. A man weighing 160 pounds is drawn up out of a well by means of a windlass, the axle of which is 8 inches in diameter, and the crank 24 inches long. Find the force required to be applied to the handle.

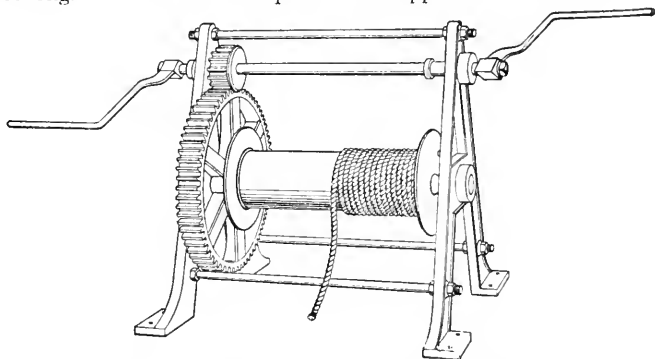

FIG. 94.—Windlass, with gearing, such as is used with a pile-driver.

2. Calculate the mechanical advantage of the windlass shown in Fig. 94. The length of the crank is 16 inches, the small wheel has 12 teeth and the large one 120, and the diameter of the drum about which the rope is wound is 6 inches.

If a force of 60 pounds be applied to each crank how great a weight can be raised? (Neglect friction.)

92. The Inclined Plane. Let a heavy mass, such as a barrel or a box, be rolled or dragged up an inclined plane AC (Fig. 95) whose length is l and height h , by means of a force F , parallel to the plane. The work done is $F \times l$.

Again the weight is raised through a height h and so, neglecting friction, the work done = $W \times h$.

$$\text{Hence } Fl = Wh,$$

$$\text{and } \frac{W}{F} = \frac{l}{h},$$

that is, the mechanical advantage is the ratio of the length to the height of the plane.

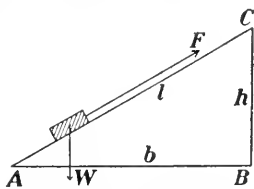

FIG. 95.—Theory of the inclined plane.

The inclined plane, in the form of a plank or a skid, is used in loading goods on a wagon or a railway car.

Taking friction into account, the mechanical advantage is not so great, and to reduce the friction as much as possible the body may be rolled up the plane.

93. The Wedge.

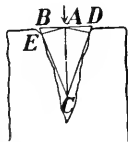
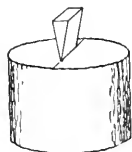

FIG. 96.—The wedge, an application of the inclined plane.

The wedge is designed to overcome great resistance through a small space. Its most familiar use is in splitting wood. Knives, axes and chisels are also examples of wedges. The resistance W (Fig. 96) to be overcome acts at right angles to the slant sides BC , DC , of the wedge, and when the wedge has been driven in as shown in the figure, the work done in pushing back one side of the split block will be $W \times AE$, and hence the work for both sides is $W \times 2AE$.

But the applied force F acts through a space AC , and so does work $F \times AC$.

$$\text{Hence } W \times 2AE = F \times AC,$$

$$\text{and } \frac{W}{F} = \frac{AC}{2AE}.$$

This is the mechanical advantage, which is evidently greater the thinner the wedge is.

This result is of little practical value, as we have not taken friction into account, nor the fact that the force F is applied as a blow, not as a steady pressure. Both of these factors are of great importance.

94. The Screw. The screw consists of a grooved cylinder which turns within a hollow cylinder or nut which it just fits. The distance from one thread to the next is called the *pitch*.

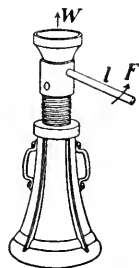

FIG. 97.—The jackscrew.

The law of the screw is easily obtained. Let l be the length of the handle by which the screw is turned (Fig. 97) and F the force exerted on it. In one rotation of the screw the end of the handle describes the circumference of a circle with radius l , that is, it moves through a distance $2\pi l$, and the work done is therefore

$$F \times 2\pi l.$$

Let W be the force exerted upwards as the screw rises, and d be the pitch. In one rotation the work done is

$$W \times d.$$

$$\text{Hence } W \times d = F \times 2\pi l,$$

$$\text{or } \frac{W}{F} = \frac{2\pi l}{d},$$

or the mechanical advantage is equal to the ratio of the circumference of the circle traced out by the end of the handle to the pitch of the screw.

In actual practice the advantage is much less than this on account of friction.

The screw is really an application of the inclined plane. If a triangular piece of paper, as in Fig. 98, is wrapped about a cylinder

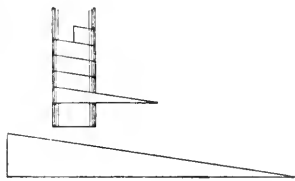

FIG. 98.—Diagram to show that the screw is an application of the inclined plane.

(a lead pencil, for instance), the hypotenuse of the triangle will trace out a spiral like the thread of a screw.

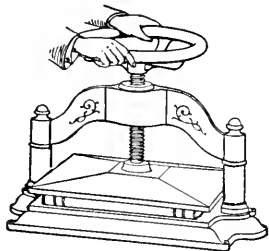

FIG. 99.—The letter press.

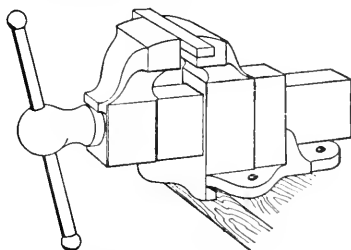

FIG. 100.—The mechanic's vice.

Examples of the screw are seen in the letter press (Fig 99), and the vice (Fig. 100).

ILLUSTRATIVE PROBLEMS

1. Why should shears for cutting metal have short blades and long handles?

2. In the driving mechanism of a self-binder, shown in Fig. 101, the

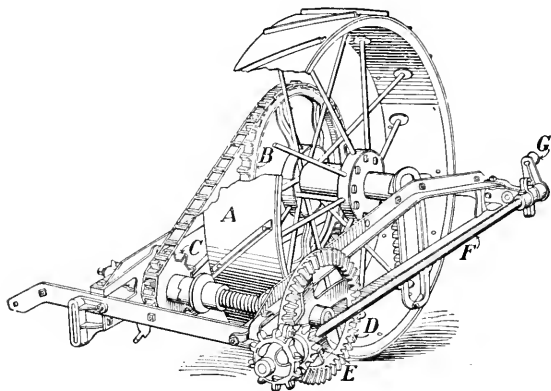

FIG. 101.—The driving part of a self-binder. The driving-wheel *A* is drawn forward by the horses. On its axis is the sprocket-wheel *B*, and this, by means of the chain drives the sprocket-wheel *C*. The latter drives the cog-wheel *D* which, again, drives the cog-wheel *E*, and this causes the shaft *F* with the crank *G* on its end to rotate.

driving-wheel *A* has a diameter of 3 feet, the sprocket-wheels *B* and *C* have 40 teeth and 10 teeth, respectively. The large gear-wheel *D* has 37 teeth and the small one *E* has 12 teeth, and the crank *G* is 3 in. long. Neglecting friction, what pull on the driving-wheel

will be required to exert a force of 10 pounds on the crank *G*?

3. Explain the action of the levers in the scale shown in Fig. 102.

If $HF^1 = 12$ ft., $F^1D^1 = 4$ inches, $MN = 36$ inches, $KM = 3$ inches, what weight on *N* would balance 2000 pounds of a load (wagon and contents)? In the scale $E^1F^1 = E^2F^2$, and $F^1D^1 = F^2D^2$, so the load is simply divided equally between the two levers.

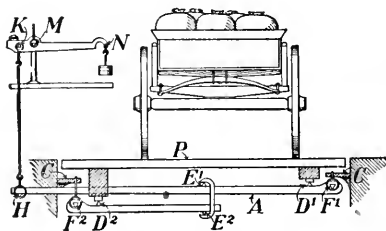

FIG. 102.—Diagram of multiplying levers in a scale for weighing hay, coal and other heavy loads. In the figure is shown one half of the system of levers, as seen from one end. The platform *P* rests on knife-edges *D*¹, *D*², the former of which is on a long lever, the latter on a short one. The knife-edges *F*¹, *F*² at the ends of these levers are supported by suspension from the brackets *C*, *C*' which are rigidly connected with the earth.

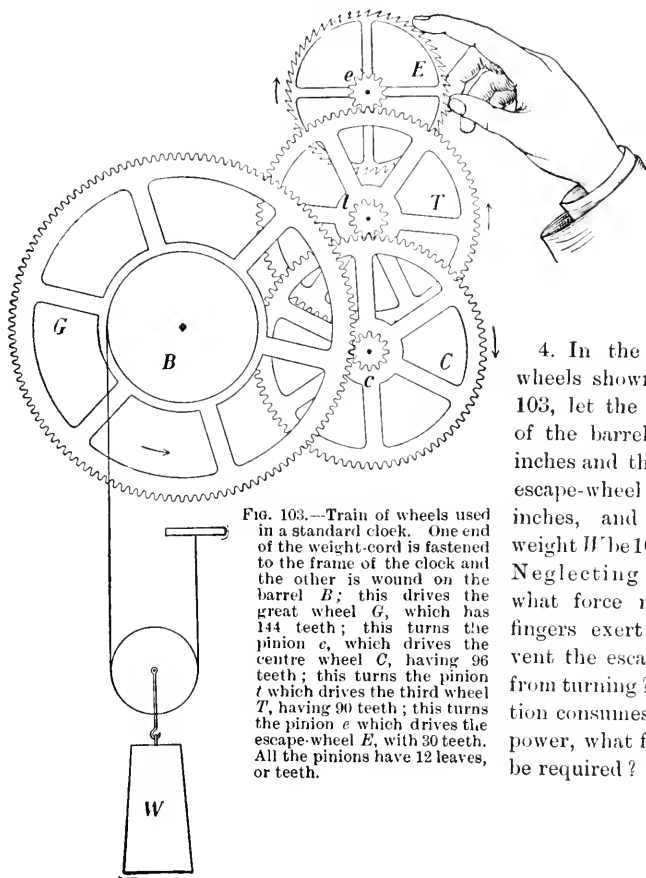

FIG. 103.—Train of wheels used in a standard clock. One end of the weight-cord is fastened to the frame of the clock and the other is wound on the barrel *B*; this drives the great wheel *G*, which has 144 teeth; this turns the pinion *c*, which drives the centre wheel *C*, having 96 teeth; this turns the pinion *t* which drives the third wheel *T*, having 90 teeth; this turns the pinion *e* which drives the escape-wheel *E*, with 30 teeth. All the pinions have 12 leaves, or teeth.

4. In the train of wheels shown in Fig. 103, let the diameter of the barrel *B* be 2 inches and that of the escape-wheel *E* be $1\frac{3}{4}$ inches, and let the weight *W* be 10 pounds. Neglecting friction, what force must the fingers exert to prevent the escape-wheel from turning? If friction consumes half the power, what force will be required?

PART III—MECHANICS OF FLUIDS

CHAPTER X

PRESSURE OF LIQUIDS

95. Transmission of Pressure by Fluids. One of the most characteristic properties of matter is its power to transmit force. The harness connects the horse with its load; the piston and connecting rods convey the pressure of the steam to the driving wheels of the locomotive. Solids transmit pressure only in the line of action of the force. Fluids act differently. If a globe and cylinder of the form shown in Fig. 104, is filled with water and a force exerted on the water by means of a piston, it will be seen that the pressure *is transmitted*, not simply in the direction in which the force is

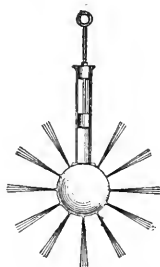

FIG. 104.—Pressure applied to the piston transmitted in all directions by the liquid within the globe.

applied, but *in all directions*; because jets of water are thrown with velocities which are apparently equal from all the apertures. If the conditions are modified by connecting U-shaped tubes partially filled with mercury with the globe, as shown in Fig. 105, it will be found that when the piston is inserted, the change in level of the mercury, caused by the transmitted pressure, is the same in each tube. This would show that the pressure applied to the piston is transmitted *equally* in all directions by the water.



FIG. 105.—Transmission shown to be equal in all directions by pressure gauges.

This principle, which is true of gases as well as liquids, may be stated as follows:—

Pressure exerted anywhere on the mass of a fluid is transmitted undiminished in all directions, and acts with the same force on all equal surfaces in a direction at right angles to them. The principle was first enunciated by Pascal, and is generally known as PASCAL'S LAW.*

96. Practical Applications of Pascal's Principle. Pascal himself pointed out how it was possible, by the application of this principle, to multiply force for practical purposes. By experimenting with pistons inserted into a closed vessel filled with water, he showed that the pressures exerted on the pistons when made to balance were in the ratio of their areas. Thus if the area of piston *A* (Fig. 106) is one square centimetre,

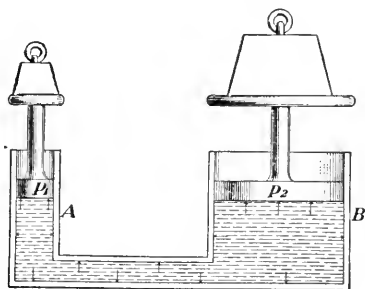

FIG. 106.—Force multiplied by transmission of pressure.

and that of *B* ten times as great, one unit of force applied to *A* will transmit ten units to *B*. It is evident that this principle has almost unlimited application. Pascal remarks, "Hence it follows that a vessel full of water is a new principle of Mechanics and a new machine for multiplying forces any degree we choose." Since Pascal's time the "new machine" has taken a great variety of forms, and has been used for a great variety of purposes.

97. Hydraulic Press. One of the most common forms is that known as Bramah's hydraulic press, which is ordinarily used whenever great force is to be exerted through short distances, as in pressing goods into bales, extracting oils from seeds, making dies, testing the strength of materials, etc. Its construction is shown in Fig. 107. *A* and *B* are two cylinders

* It appears in Pascal's *Traité de l'équilibre des liqueurs*, written in 1653 but first published in 1663, one year after the author's death

connected with each other and with a water cistern by pipes closed by valves V_1 and V_2 . In these cylinders work pistons P_1 and P_2 through water-tight collars, P_1 being

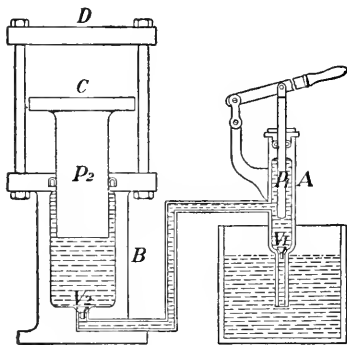

FIG. 107.—Bramah's hydraulic press.

moved by a lever. The bodies to be pressed are held between plates C and D . When P_1 is raised by the lever, water flows up from the cistern through the valve V_1 and fills the cylinder A . On the down-stroke the valve V_1 is closed and the water is forced through the valve V_2 into the cylinder B , thus exerting a force on the piston P_2 , which will be as many times that applied to P_1 as the area of the cross-section of P_2 is that of the cross-section of P_1 . It is evident that by decreasing the size of P_1 , and increasing that of P_2 , an immense force may be developed by the machine. While this is true, it is to be noted that the upward movement of P_2 will be very slow, because the action of the machine must conform to the law enunciated in §81, that is,

the force acting on $P_1 \times$ the distance through which it moves = the force acting on $P_2 \times$ the distance through which it moves.

98. The Hydraulic Elevator. Another important application of the multiplication of force through the principle of equal transmission of pressure by fluids is the hydraulic elevator, used as a means of conveyance from

Fig. 108. — Hydraulic elevator. The diagram shows a vertical shaft with a piston A in the middle. Above the piston is a chamber E. Below the piston is a chamber C. A pipe F enters the shaft from the side, and a pipe D exits. The shaft is surrounded by a fluid medium.

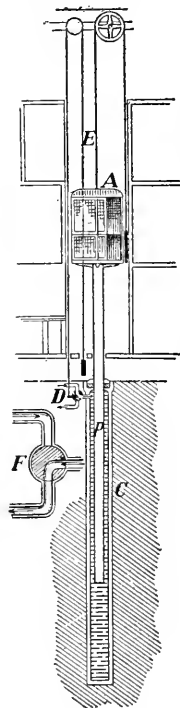

FIG. 108.—Hydraulic elevator.

floor to floor in buildings. In its simplest form it consists of a cage *A*, supported on a piston *P*, which works in a long cylindrical tube *C*. (Fig. 108.) The tube is connected with the water mains and the sewers by a three-way valve *D* which is actuated by a cord *E* passing through the cage. When the cord is pulled up by the operator, the valve takes the position shown at *D*, and the cage is forced up by the pressure on *P* of the water which rushes into *C* from the mains. When the cord is pulled down, the valve takes the position shown at *F* (below), and the cage descends by its own weight forcing the water out of *C* into the sewers.

When a higher lift, or increased speed is required, the cage is connected with the piston by a system of pulleys which multiplies, in the movement of the cage, the distance travelled by the piston.

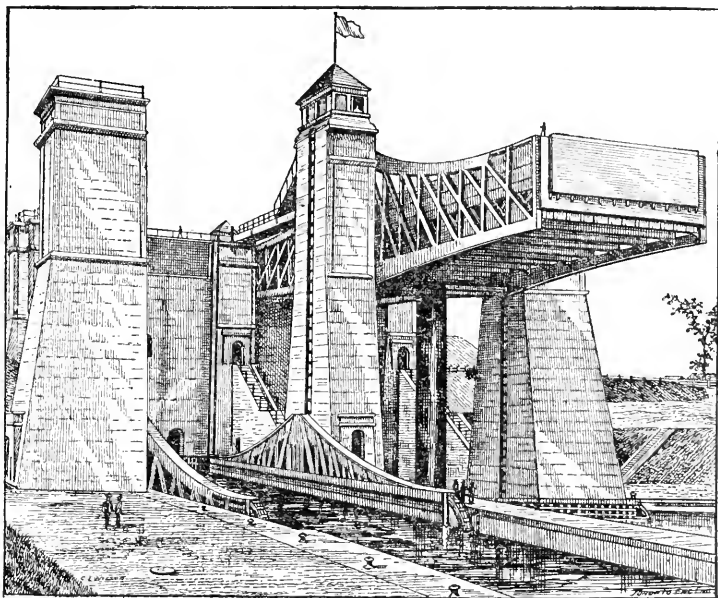

FIG. 109.—Hydraulic lift-lock at Peterborough, Ont., capable of lifting a 140-foot steamer 65 feet.

99. Canal Lift-Lock. The hydraulic lift-lock, designed to take the place of ordinary locks where a great difference of level is found in short distances, is another application of the principle of equal transmission. Fig. 109 gives a general view of the Peterborough Lift Lock, the largest of its kind in the

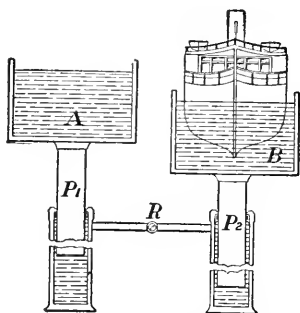

FIG. 110.—Principle of the lift-lock.

world, and Fig. 110 is a simple diagrammatic section showing its principle of operation. The lift-lock consists of two immense hydraulic elevators, supporting on their pistons P_1 and P_2 tanks A and B in which float the vessels to be raised or lowered. The presses are connected by a pipe containing a valve R which can be operated by the lockmaster in his cabin at the top of the central tower. To perform the lockage, the vessel is towed into one tank and the gates at the end leading from the canal are closed. The upper tank is then made to descend by being loaded with a few inches more of water than the lower. On opening the valve the additional weight in the upper tank forces the water from its press into the other, and it gradually descends while the other tank is raised. The action, it will be observed, is automatic, but hydraulic machinery is provided for forcing water into the presses to make up pressure lost through leakage.

100. Pressure due to Weight. Our common experiences in the handling of liquids give us evidence of force within their mass. When, for example, we pierce a hole in a water-pipe or in the side or the bottom of a vessel filled with water, we find that the water rushes out with an intensity which we know, in a general way, to depend on the height of the water above the opening. Again, if we hold a cork at the bottom

of a vessel containing water, and let it go, it is forced up to the surface of the water, where it remains, its weight being supported by the pressure of the liquid on its under surface.

101. Relation between Pressure and Depth. Since the lower layers of the liquid support the upper layers, it is to be expected that this force within the mass, due to the action of gravity, will increase with the depth. To investigate this relation, prepare a pressure gauge of the form shown in Fig. 111 by stretching a rubber membrane over a thistle-tube *A*, which is connected by means of a rubber tube with a U-shaped glass tube *B*, partially filled with water. The action of the gauge is shown by pressing on the membrane. Pressure transmitted to the water by the air in the tube is measured by the difference in level of the water in the branches of the U-tube.

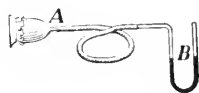

FIG. 111.—Pressure gauge.

Now place *A* in a jar of water (which should be at the temperature of the room), and gradually push it downward (Fig. 112). The changes in the level of the water in the branches of the U-shaped tube indicate an increase in pressure with the increase in depth. Careful experiments have shown that this *pressure increases from the surface downward in direct proportion to the depth*.

102. Pressure Equal in all Directions at the same Depth. If the thistle-tube *A* is made to face in different directions

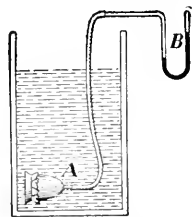

FIG. 112.—Investigation of pressure within the mass of a liquid by pressure gauge.

while the centre of the membrane is kept at the same depth, no change in the difference in level of the water in the U-shaped tube is observed. Evidently the magnitude of the force at any point within the fluid mass is independent of the direction of pressure. *The upward, downward, and lateral pressures are equal at the*

same depth.

103. Magnitude of Pressure due to Weight. The downward pressure of a liquid, say water, on the bottom of a vessel with vertical sides is obviously the weight of the liquid. But,

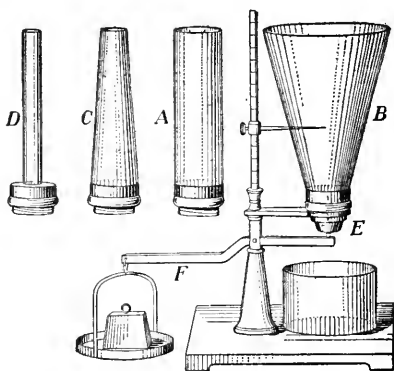

FIG. 113.—Pressures on the bottoms of vessels of different shapes and capacities.

if the sides of the vessel are not vertical, the magnitude of the force is not so apparent. The apparatus shown in Fig. 113 may be used to investigate the question. *A*, *B*, *C*, and *D* are tubes of different shapes but made to fit into a common base. *E* is a movable bottom held in position by a lever and weight. Attach the cylindrical tube to the

base, and support the bottom *E* in position. Now place any suitable weight in the scale-pan and pour water into the tube until the pressure detaches the bottom. If the experiment be repeated, using in succession the tubes *A*, *B*, *C*, and *D*, and marking with the pointer the height of the water when the bottom is detached, it will be found that the height is the same for all tubes, so long as the weight in the scale-pan remains unchanged. The pressure on the bottom of a vessel filled with a given liquid is, therefore, dependent only on the depth. It is independent of the form of the vessel and of the amount of liquid which it contains. This conclusion, is sometimes known as the *hydrostatic paradox*, because it would seem impossible that a small quantity of liquid, like that contained in tube *D*, could exert the same force on the bottom as that exerted by the larger quantity contained in *B*.

104. Explanation of the Paradox. By an arrangement very similar to that just described Pascal first demonstrated the truth of his Principle, and also showed how to apply it to explain the apparent contradiction.

Take, for example, the case of a vessel *D* (Fig. 113). The pressure on the bottom *DF* (Fig. 114) is equal to the weight of the water in *CDFE*, together with the pressure due to the water in *LABK*. Now on the lower faces of *CK* and *BE* there is an upward pressure (which is that due to a depth *AB* of the water), and these surfaces exert upon the water a reaction downwards, which is transmitted to the base. If the spaces *HK* and *AE* were filled with water the pressure downwards on *CK* and *BE* would just balance the upward pressure on them.

Hence the entire pressure on the bottom is equal to the weight of the water in *HD'FG*, or the pressure on the bottom is the same as if the vessel had vertical sides.

By an arrangement very

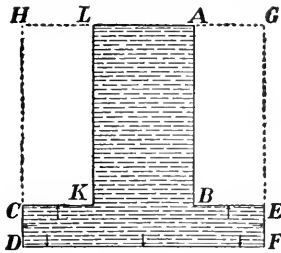

FIG. 114.—Explanation of the hydrostatic paradox.

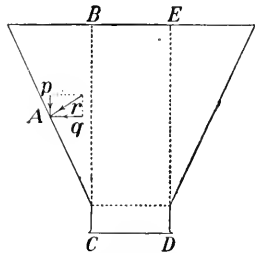

FIG. 115.—Explanation of hydrostatic paradox. *r*, pressure of liquid at *A*; *p*, vertical component; *q*, horizontal component.

Now take the case of the funnel-shaped vessel *B* (Fig. 113). Since the pressure at any point in the wall is perpendicular to the wall, it may have a vertical component which is balanced by the reaction of the wall at the point (Fig. 115). Hence the weight of the water is supported in part by the sides of the vessel, the bottom supporting only the vertical column *BCDE*.

105. Surface of a Liquid in Connecting Tubes. If a liquid is poured into a series of connecting tubes

(Fig. 116), it will rise to the same horizontal plane in all the tubes. The reason is apparent. Consider, for example, the tubes *A* and *B*. Let *a* and *b* be two points in the same horizontal plane. The liquid is at rest only on the condition that the

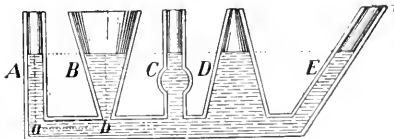

FIG. 116.—Surface of a liquid in connecting tubes in the same horizontal plane.

pressure at *a* in the direction

ab is equal to the pressure at b in the direction ba ; but since the pressure at either of these points varies as its depth only, and is independent of the shape of the vessel, or of the quantity of the liquid in the tubes, the height of the liquid in A above a must be the same as the height in B above b .

This principle, that "water seeks its own level," is in a variety of ways, of practical importance. Possibly the common method of supplying cities with water furnishes the most striking example. Fig. 117 shows the main features of a

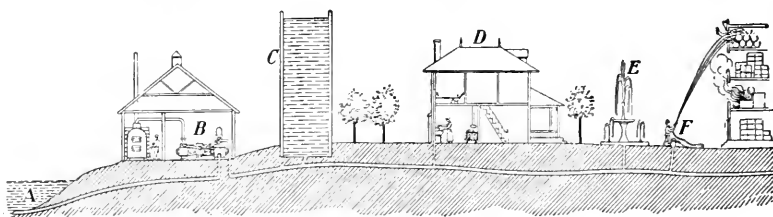

FIG. 117.—Water supply system. A , source of water supply; B , pumping station; C , stand-pipe; D , house supplied with water; E , fountain; F , hydrant for fire hose.

modern system. While there are various means by which the water is collected and forced into a reservoir or stand-pipe, the distribution in all cases depends on the principle that, however ramified the system of service pipes, or however high or low they may be carried on streets or in buildings, there is a tendency in the water which they contain to rise to the level of the water in the original source of supply connected with the pipes.

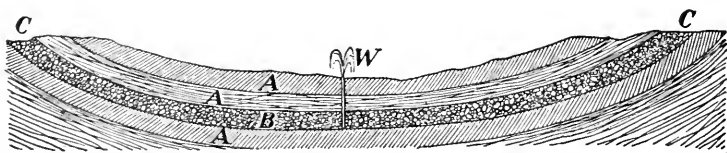

FIG. 118.—Artesian basin. A , impermeable strata. B , permeable stratum. C, C , points where permeable stratum reaches the surface. W , artesian well.

106. Artesian Wells. The rise of water in artesian wells is also due to the tendency of a liquid to find its own level.

These wells are bored at the bottom of cup-shaped basins (Fig. 118), which are frequently many miles in width. The upper strata are impermeable, but lower down is found a stratum of loose sand, gravel, or broken stone containing water which has run into it at the points where the permeable stratum reaches the surface. When the upper strata are pierced the water tends to rise with a force more or less great, depending on the height of the head of water exerting the pressure.

PROBLEMS

1. A closed vessel is filled with liquid, and two circular pistons, whose diameters are respectively 2 cm. and 5 cm. inserted. If the pressure on the smaller piston is 50 grams, find the pressure on the larger piston when they balance each other.

2. The diameter of the large piston of a hydraulic press is 100 cm. and that of the smaller piston 5 cm. What force will be exerted by the press when a force of 2 kilograms is applied to the small piston?

3. The diameter of the piston of a hydraulic elevator is 14 inches. Neglecting friction, what load, including the weight of the cage, can be lifted when the pressure of the water in the mains is 75 pounds per sq. inch?

4. What is the pressure in grams per sq. cm. at a depth of 100 metres in water? (Density of water one gram per c.c.)

5. The area of the cross-section of the piston P (Fig. 119), is 120 sq. cm. What weight must be placed on it to maintain equilibrium when the water in the pipe B stands at a height of 3 metres above the height of the water in A ?

6. The water pressure at a faucet in a house supplied with water by pipes connected with a distant reservoir is 80 pounds per sq. inch when the water in the system is at rest. What is the vertical height of the surface of the water in the reservoir above the faucet? (1 lb. water = 27.73 c.c.; see Table opposite page 1.)

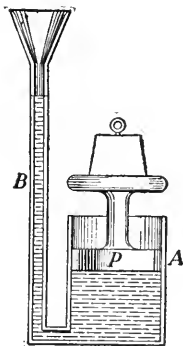

FIG. 119.

CHAPTER XI

BUOYANCY OF FLUIDS

107. Nature of Buoyancy. When a body is immersed in a liquid every point of its surface is subjected to a pressure which is perpendicular to the surface at that point, and which varies as the depth of that point below the surface of the liquid. When these pressures are resolved into horizontal and vertical components, the horizontal components balance each other; and since the pressure on the lower part of the body is greater than that on the upper part, the resultant of all the forces acting upon the body must be vertical and act upward. This force is termed the *resultant vertical pressure* or *buoyancy of the fluid*.

Consider, for example, the resultant pressure on a solid in the form of a cube, whose edge is 1 cm., immersed in water with its upper face horizontal at a depth of, say, 1 cm. below the surface.

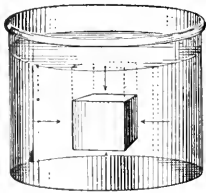

FIG. 120.—Buoyant force of a liquid on a solid.

(Fig. 120). Obviously the pressures on the vertical sides balance. The resultant force, which is vertical, is the difference between the pressure on the top and that on the bottom; but the pressure on the top is the weight of a column of water 1 sq. cm. in section and 1 cm. long, and the pressure on the bottom is the weight of a similar column 2 cm. long (§102). Hence the cube is buoyed up with a force which is the weight of a column of water 1 sq. cm. in section and 1 cm. long, or the weight of water equal in volume to the solid, that is, 1 gram.

108. To determine experimentally the amount of the **Buoyant Force** which a **Liquid** exerts on an **Immersed Body**. Take a brass cylinder *A*, which fits exactly into a hollow socket *B*. Hook the cylinder to the bottom of the socket and counterpoise them on a balance. Surround the cylinder with water (Fig. 121). It will be found that the cylinder is buoyed up by the water, but that equilibrium is restored when the socket is filled with water. Hence the buoyant force of the water on the cylinder equals the weight of a volume of water equal to the volume of the cylinder.

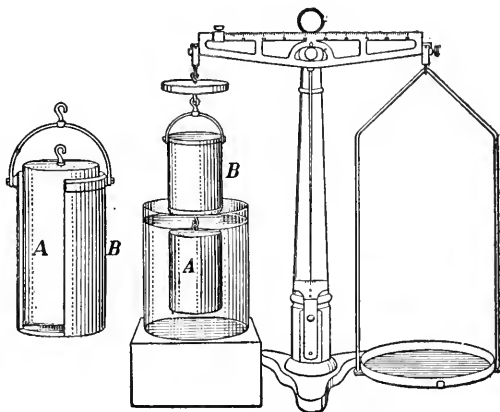

Fig. 121.—Determination of buoyant force.

In general terms, *the buoyant force exerted by a fluid upon a body immersed in it, is equal to the weight of the fluid displaced by the body; or a body when weighed in a fluid loses in apparent weight an amount equal to the weight of the fluid which it displaces.* This is known as the **PRINCIPLE OF ARCHIMEDES**.

Archimedes had been asked by Hiero to determine whether a crown which had been made for him was of pure gold or alloyed with silver. It is said that the action of the water when in a bath suggested to him the principle of buoyancy as the key to the solution of the problem. The story is that he leaped from his bath, and rushed through the streets of Syracuse, crying "Eureka! Eureka!" (I have found it, I have found it.)

109. Principle of Flotation. It is evident that if the weight of a body immersed in a liquid is greater than the weight of the liquid displaced by it, that is, greater than the buoyant force, the body will sink; but if the buoyant force is greater, it will continue to rise until it reaches the surface. Here it will come to rest when a portion of it has risen above the surface and the weight of the liquid displaced by the immersed portion equals the weight of the body. For example, consider again the cube referred to in Fig. 120. If its weight is less than one gram, for definiteness say 0.6 gram, it will float in water. In this case the downward pressure on the top has disappeared and the weight of the cube alone is supported by the pressure on the bottom, which equals the weight of a column of water 1 sq. cm. in section and 0.6 cm. deep.

The conditions of flotation may be demonstrated experimentally by placing a light body, a piece of wood for example, on the surface of water in a graduated tube (Fig. 123). If the volume of water displaced is noted and its weight calculated, it will be found to be equal to the weight of the body.

PROBLEMS

1. A cubic foot of marble which weighs 160 pounds is immersed in water. Find (1) the buoyant force of the water on it, (2) the weight of the marble in water. (1 c. ft. water = 62.3 lbs. § 17).
2. Twelve cubic inches of a metal weigh 5 pounds in air. What is the weight when immersed in water?
3. If 3,500 c.c. of a substance weigh 6 kg., what is the weight when immersed in water?
4. A piece of aluminium whose volume is 6.8 c.c. weighs 18.5 grams. Find the weight when immersed in a liquid twice as heavy as water.
5. One cubic decimetre of wood floats with $\frac{3}{8}$ of its volume immersed in water. What is the weight of the cube?
6. A cubic centimetre of cork weighs 250 mg. What part of its volume will be immersed if it is allowed to float in water?

7. The cross-section of a boat at the water-line is 150 sq. ft. What additional load will sink it 2 inches?

8. A piece of wood whose mass is 100 grams floats in water with $\frac{3}{4}$ of its volume immersed. What is its volume?

9. Why will an iron ship float on water, while a piece of the iron of which it is made sinks?

10. A vessel of water is on one scale-pan of a balance and counterpoised. Will the equilibrium be disturbed if a person dips his fingers into the water without touching the sides of the vessel? Explain.

11. A piece of coal is placed in one scale-pan of a balance and iron weights are placed in the other scale-pan to balance it. How would the equilibrium be affected if the balance, coal and weights were now placed under water? Why?

12. What is the least force which must be applied to a cubic foot of wood whose mass is 40 lbs. that it may be wholly immersed in water?

13. Referring to Fig. 110, answer the following question: If the depth of the water in the press *A* is the same as that in the press *B* which contains the vessel, which press will be the heavier?

CHAPTER XII

DETERMINATION OF DENSITY

110. Determination of the Density of a Solid Heavier than Water. To determine the density of a body it is necessary to ascertain its mass and its volume.

The mass is determined by weighing. The volume is, as a rule, most easily and accurately found by an application of Archimedes' Principle.

For example, if a body whose mass is 20 grams, weighs 16 grams in water, the mass of the water displaced is $20 - 16 = 4$ grams. But the volume of 4 grams of water = 4 c.c. The volume of the body is, therefore, 4 c.c. Hence the density, or mass per unit volume, of the substance must be $20 \div 4 = 5$ grams per c.c.

Next, let m grams = weight or mass of a body in air,

and m_1 " = its weight in water.

Then $m - m_1$ " = loss of weight in water,

= wt. of water equal in vol. to body.

Now, mass of a body = its volume \times its density; and since in the C.G.S. system the density of water = 1,

$m - m_1$ c.c. = vol. of water equal in vol. to body,
= volume of body.

That is, the volume of a body is numerically equal to its loss of weight in water.

Hence, density (*in gms. per c.c.*)

$$= \frac{\text{mass (in grams)}}{\text{loss of wt. in water (in gms.)}}$$

The number thus obtained also expresses the specific gravity of the body. (§ 18.)

If the solid is soluble in water its density may be obtained by weighing it in a liquid of known density, in which it is not soluble, and determining, as above, the ratio of its mass to that of an equal volume of the liquid, and then multiplying the result by the density of the liquid.

111. Determination of the Density of a Solid Lighter than Water. If a solid is lighter than water, its density may be determined by attaching to it a heavy body to cause it to sink beneath the surface.

The following method may be used:—

1st. Weigh the body in air. Let this be m grams.

2nd. Attach a sinker and weigh both, *with the sinker only in water*. Let this be m_1 grams.

3rd. Weigh both, *with both in water*. Let this be m_2 grams.

Now the only difference between the second and third operations is that in the former case the body is weighed in air, in the latter in water. The sinker is in the water in both cases.

Hence $m_1 - m_2 =$ buoyancy of the water on the body, and the density (in grams per c.c.) = $\frac{m}{m_1 - m_2}$.

The number thus obtained expresses also the specific gravity of the body.

112. Density of a Liquid by the Specific Gravity Bottle. As in the case of solids, the problem is to determine the volume and the mass of the liquid.

The volume of a sample of the liquid may be obtained by pouring it into a bottle so constructed as to contain at a specified temperature a given volume of liquid, usually 100 c.c. at 15° C. To render complete filling easy, the bottle is provided with a closely-fitting stopper perforated with a fine bore through which excess of liquid escapes (Fig. 122).



FIG. 122.—Specific gravity bottle.

The mass of the liquid is obtained by taking the difference between the weights of the bottle when filled with the liquid, and when empty.

If m denotes the mass of the liquid and v the volume of the bottle, density of liquid = $\frac{m}{v}$.

If the volume of the bottle is not given, it may be found by taking the difference between its weight when empty and when filled with water.

113. Density of a Liquid by Archimedes' Principle.

Archimedes' Principle may also be applied to determine the densities of liquids.

Take a glass sinker whose mass is, say m grams, and weigh it first in the liquid whose density is to be determined, and then in water. If m_1 grams denotes the weight of the sinker in the liquid and m_2 grams its weight in water,

$m - m_1$ grams = mass of liquid displaced by sinker,

$m - m_2$ grams = mass of water displaced by sinker.

Hence volume of the sinker = $m - m_2$ c.c.,

and density of liquid (in grams per c.c.) = $\frac{m - m_1}{m - m_2}$.

114. Density of a Liquid by means of the Hydrometer.

The hydrometer is an instrument designed to indicate directly the density of the liquid by the depth at which it floats in it.

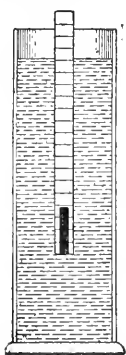

FIG. 123.—Illustration of the principle of the hydrometer.

The principle underlying the action of this instrument may be illustrated as follows. Take a rectangular rod of wood 1 sq. cm. in section and 20 cm. long, and bore a hole in one end. After inserting sufficient shot to cause the rod to float upright in water (Fig. 123) plug up the hole and dip the rod in hot paraffin to render it impervious to water. Mark off on one of the long faces a centimetre scale. Now place the rod in water, and suppose it to sink to a depth of 16 cm. when floating. Then the weight of the rod = weight of water displaced = 16 grams.

Again, suppose it to sink to a depth of 12 cm. in a liquid whose density is to be determined.

Then, since the weight of liquid displaced equals weight of the rod,

$$12 \text{ c.c. of the liquid} = 16 \text{ grams,}$$

$$\text{And density of the liquid} = \frac{1}{1\frac{2}{3}} \text{ gram per c.c.}$$

$$\text{Or, density of the liquid} = \frac{\text{vol. of water displaced by a floating body}}{\text{vol. of the liquid displaced by the same body}}$$

A hydrometer for commercial purposes is usually constructed in the form shown in Fig. 124. The weight and volume are so adjusted that the instrument sinks to the division mark at the lower end of the stem in the densest liquid to be investigated and to the division mark in the upper end in the least dense liquid. The scale on the stem indicates directly the densities of liquids between these limits. The float *A* is usually made much larger than the stem to give sensitiveness to the instrument.

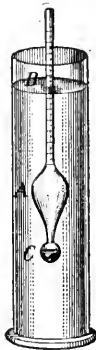

Fig. 124.—The hydrometer.

As the range of an instrument of this class is necessarily limited, special instruments are constructed for use with different liquids. For example, one instrument is used for the densities of milks, another for alcohols, and so on.

PROBLEMS

(For table of densities see § 17)

1. A body whose mass is 6 grams has a sinker attached to it and the two together weigh 16 grams in water. The sinker alone weighs 24 grams in water. What is the density of the body?

2. A body whose mass is 12 grams has a sinker attached to it and the two together displace when submerged 60 c.c. of water. The sinker alone displaces 12 c.c. What is the density of the body?

3. A body whose mass is 60 grams is dropped into a graduated tube containing 150 c.c. of water. If the body sinks to the bottom and the water rises to the 200 c.c. mark, what is the density of the body?

4. If a body when floating in water displaces 12 c.c., what is the density of a liquid in which when floating it displaces 18 c.c.?

5. A piece of metal whose mass is 120 grams weighs 100 grams in water and 104 grams in alcohol. Find the volume and density of the metal, and the density of the alcohol.

6. A hydrometer floats with $\frac{2}{3}$ of its volume submerged when floating in water, and $\frac{3}{4}$ of its volume submerged when floating in another liquid. What is the density of the other liquid?

7. A cylinder of wood 8 inches long floats vertically in water with 5 inches submerged. (a) What is the specific gravity of the wood? (b) What is the specific gravity of the liquid in which it will float with 6 inches submerged? (c) To what depth will it sink in alcohol whose specific gravity is 0.8?

8. The specific gravity of pure milk is 1.086. What is the density of a mixture containing 500 c.c. of pure milk and 100 c.c. of water?

9. How much silver is contained in a gold and silver crown whose mass is 407.44 grams, if it weighs 385.44 grams in water? (Density of gold 19.32 and of silver 10.52 grams per c.c.)

CHAPTER XIII

PRESSURE IN GASES

115. Has Air Weight? This question puzzled investigators from the time of Plato and Aristotle down to the seventeenth century, when it was answered by Galileo and Guericke.

Galileo convinced himself that air had weight by proving that a glass globe filled with air under high pressure weighed more than the same globe when filled with air under ordinary conditions. Guericke, the inventor of the air-pump, showed that a copper globe weighed more when filled with air than when exhausted.

The experiments of Galileo and Guericke may be repeated with a glass flask (Fig. 125) fitted with a stop-cock. If the flask is weighed when filled with air under ordinary pressure, then weighed when the air has been compressed into it with a bicycle pump, and again when the air has been exhausted from it with an air-pump, it is found that the first weight is less than the second but greater than the third.

Since the volume of a mass of air varies with changes in temperature and pressure, the weight of a certain volume will be constant only at a fixed temperature and pressure. Exact quantitative experiments have shown that the mass of a litre of air at 0° C. and under normal pressure of the air at sea level (760 mm. of mercury) is 1.293 grams.

116. Pressure of Air. It is evident that since air has weight it must, like liquids, exert pressure upon all bodies with which it is in contact. Just as the bed of the ocean sustains enormous pressure from the weight of the water resting on it, so the surface of the earth, the bottom of the

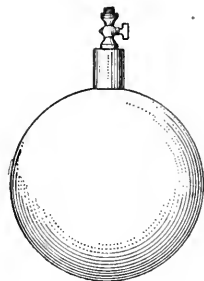

FIG. 125.—Globe for weighing air.

aerial ocean in, which we live, is subject to a pressure due to the weight of the air supported by it. This pressure will, of course, vary with the depth. Thus the pressure of the atmosphere at Victoria, B.C., on the sea-level is greater than at points on the mountains to the east.

The pressure of the air may be shown by many simple experiments. For example, tie a piece of thin sheet rubber over the mouth of a thistle-tube (Fig. 126) and exhaust the air from the bulb by suction or by connecting it with the air-pump. As the air is exhausted the rubber is pushed inward by the pressure of the outside air.

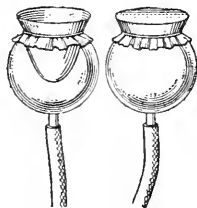

Fig. 126.—Rubber membrane forced inwards by pressure of the air.

Again, if one end of a straw or tube is thrust into water and the air withdrawn from it by suction, the water is forced up into the tube. This phenomenon was known for ages but did not receive an explanation until the facts of the weight and pressure of the atmosphere were established. It was explained on the principle that Nature had a horror for empty space.

The attention of Galileo was called to this problem of the *horror vacui** in 1640 by his patron, the Grand Duke of Tuscany, who had found that water could not be lifted more than 32 feet by a suction pump. Galileo inferred that "resistance to vacuum" as a force had its limitations and could be measured; but although he had, as we have seen, proved that air has weight, he did not see the connection between the facts. After his death the problem was solved by his pupil, Torricelli, who showed definitely that the resistance to a vacuum was the result of the pressure of the atmosphere due to its weight.

117. The Torricellian Experiment. Torricelli concluded that since a water column rises to a height of 32 feet, and since mercury is about 14 times as heavy as water, the

*Horror of a vacuum.

corresponding mercury column should be $\frac{1}{14}$ as long as the water column. To confirm his inference an experiment similar to the following was performed under his direction by Vincenzo Viviani, one of his pupils.

Take a glass tube about one metre long (Fig. 127), closed at one end, and fill it with mercury. Stopping the open end with the finger, invert it and place it in a vertical position, with the open end under the surface of the mercury in another vessel. Remove the finger. The mercury will fall a short distance in the tube, and after oscillating will come to rest with the surface of the mercury in the tube between 28 and 30 inches above the surface of the mercury in the outer vessel.

Torricelli concluded rightly that the column of mercury was sustained by the pressure of the air on the surface of the mercury in the outer vessel. This conclusion was confirmed by

Pascal, who showed that the length of the mercury column varied with the altitude. To obtain decisive results he asked his brother-in-law, Périer, who resided at Clermont in the south of France, to test it on the Puy de Dôme, a near-by mountain over 1,000 yards high. Using a tube about 4 ft. long, which had been filled with mercury and then inverted in a vessel containing mercury, Périer found that while at the base the mercury column was 26 in. $3\frac{1}{2}$ lines* high, at the summit it was only 23 in. 2 lines, the fall in height being 3 in.,

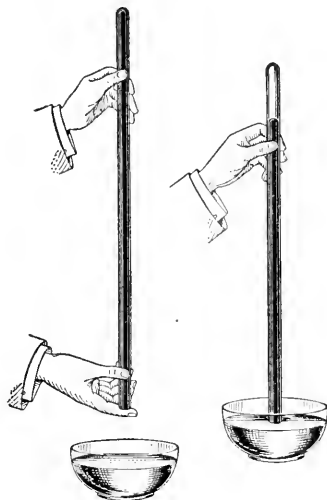

FIG. 127.—Mercury column sustained by the pressure of the air.

*The French inch then used = $2\frac{3}{4}$ cm., and 1 line = $\frac{1}{12}$ inch.

$1\frac{1}{2}$ lines (over 8 cm.). This result, he remarks, "ravished us all with admiration and astonishment."* Later, Pascal tried the experiment at the base and the summit of the tower of Saint-Jacques-de-la-Boucherie, in Paris, which is about 150 ft. high. He found a difference of more than 2 lines (about $\frac{1}{2}$ cm.).

QUESTIONS AND PROBLEMS

1. Fill a tumbler and hold it inverted in a dish of water as shown in Fig. 128. Why does the water not run out of the tumbler into the dish?

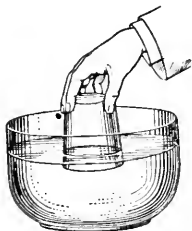

FIG. 128.

2. Fill a bottle with water and place a sheet of writing paper over its mouth. Now, holding the paper in position with the palm of the hand, invert the bottle. (Fig. 129.)

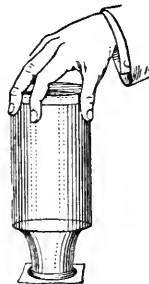

FIG. 129.

Why does the water remain in the bottle when the hand is removed from the paper?

3. Take a bent-glass tube of the form shown in Fig. 130. The upper end of it is closed, the lower open. Fill the tube with water. Why does the water not run out when it is held in a vertical position?



FIG. 130.

4. Why must an opening be made in the upper part of a vessel filled with a liquid to secure a proper flow at a faucet inserted at the bottom?

5. Fill a narrow-necked bottle with water and hold it mouth downward. Explain the action of the water.

6. A flask weighs 280.60 gm. when empty, 284.19 gm. when filled with air and 3060.60 gm. when filled with water. Find the weight of 1 litre of air.

* "Ce qui nous ravit tous d'admiration et d'étonnement." This account is taken from Périer's letter to Pascal, dated September 22, 1643.

118. The Barometer. Torricelli pointed out that the object of his experiment was "not simply to produce a vacuum, but to make an instrument which shows the mutations of the air, now heavier and dense, now lighter and thin."* The modern mercury barometer designed for this purpose is the same in principle as that constructed by Torricelli. With this instrument the pressure of the atmosphere is measured by the pressure exerted by the column of mercury which balances it, and changes in pressure are indicated by corresponding changes in the height of the mercury column.

Two forms of the instrument are in common use.

119. The Cistern Barometer. This form applies directly to the original Torricellian experiment. The vessel or cistern and tube are permanently mounted, and an attached scale measures the height of the surface of the mercury in the tube above the surface of the mercury in the cistern.

A convenient form of this instrument is shown in Figs. 131, 132. The cistern has a flexible leather bottom which can be moved up and down by a screw *C* in order to adjust the

mercury level. Before taking the reading, the surface of the mercury in the cistern is brought to a fixed level indicated by the tip of the pointer *P*, which is the zero of the barometer scale. The height of the column is then read directly from a scale, engraved on the case of the instrument. A vernier†

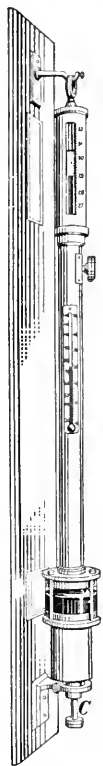

FIG. 131.—The cistern barometer.

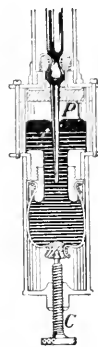

FIG. 132.—Section of the cistern.

* Extract from letter written by Torricelli, in 1644, to M. A. Ricci, in Rome, first published in 1663.

† An explanation of the vernier is given in the laboratory *Manual* designed to accompany this book.

is usually employed to determine the reading with exactness.

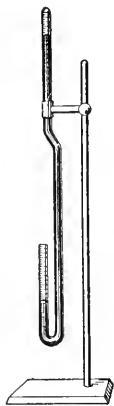

FIG. 133.—Siphon barometer.

120. The Siphon Barometer. This barometer consists of a tube of the proper length closed at one end and bent into U-shape at the other. (Fig. 133.) When filled and placed upright the mercury in the longer branch is supported by the pressure of the air on the surface of the mercury in the shorter. A scale is attached to each branch. The upper scale gives the height of the mercury in the closed branch above a fixed point, and the lower scale the distance of the mercury in the open branch below the same fixed point. The sum of the two readings is the height of the barometer column.

121. Aneroid Barometer. As its name implies,* this is a barometer constructed without liquid. (Fig. 134.) In this form the air presses against the flexible corrugated cover of a circular, air-tight, metal box *A*, from which the air is partially exhausted. The cover, which is usually supported by a spring *S*, responds to the pressure of the atmosphere, being forced in when the pressure is increased, and springing out when it is decreased. The movement of the cover is multiplied and transmitted to an index hand *B* by a system of delicate levers and a chain or by gears. The circular scale is graduated by comparison with a mercury barometer.

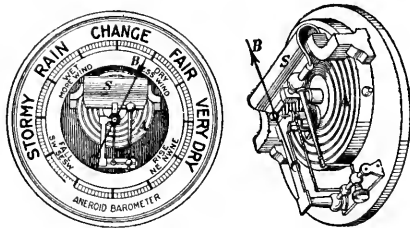

FIG. 134.—Aneroid barometer.

The aneroid is not so accurate as the mercury barometer, but, on account of its portability and its sensitiveness, is

* Greek, *a* = not, *neros* = wet.

coming into very common use. It is specially serviceable for determining readings to be used in computing elevations.

122. Practical Value of the Barometer; Atmospheric Pressure. By the barometer we can determine the pressure of the atmosphere at any point. For example, to measure the pressure per sq. cm. of the air at a point where the mercury barometer stands at 76 cm., we have but to find the weight of the column of mercury balanced by the atmospheric pressure at this point; that is, we have to find the weight of a column of mercury 1 sq. cm. in section and 76 cm. high. The volume of the column is 76 c.c., and taking the density of mercury as 13.6 gram per c.c., this weight will be

$$76 \times 13.6 = 1033.6 \text{ grams.}$$

In general terms, if a is the area pressed, and h the height of a barometer, using a liquid whose density is d ,

ah = volume of liquid in barometric column,

ahd = weight of liquid in barometric column,

= pressure of atmosphere on area a ,

and hd = pressure of atmosphere on unit area.

123. Variations in Atmospheric Pressure. By continually observing the height of the barometer at any place we learn that the atmospheric pressure is constantly changing. Sometimes a decided change takes place within an hour.

Again, by comparing the simultaneous readings of barometers distributed over a large stretch of country we find that the pressure is different at different places.

124. Construction of the Weather Map. The Meteorological Service has stations in all parts of the country at which observers regularly record at stated hours of each day the prevailing meteorological conditions. Twice each day these simultaneous observations are sent by telegraph to the head office at Toronto. These reports include:—The barometer reading, the temperature, the direction and

velocity of the wind, and the rainfall, if any. The information thus received is entered upon a map, such as that shown in Fig. 135. Places having equal barometric pressures are joined by lines called *isobars*,* the successive lines showing difference of pressure due to $\frac{1}{10}$ inch of mercury. The circles show the state of the sky and the arrows indicate the direction of the wind.

The Map given shows the conditions existing at 8 p.m., February 15th, 1910. It will be seen that there were certain areas of low and of high pressure enclosed by the isobars. For instance a "low" was central over Michigan while a "high" was central over Dakota and southern Saskatchewan. In all weather maps there are found sets of these areas, but no two maps are ever quite the same.

On account of the difference in pressure there is a motion of the air inwards towards the centre of the "low," and outwards from the centre of the "high." But these motions are not directly towards or away from the centre. An examination of the arrows on the map will show that there is a motion about the centre. In the case of the "low" this motion is *contrary* to the direction of motion of the hands of a clock, while in the case of the "high" the motion is *with* the hands of the clock. Through a combination of the motions the air moves spirally inwards to the centre of low pressure and spirally outwards from the centre of high pressure. The system of winds about a centre of low pressure is called a *cyclone*; that about a centre of high pressure, an *anti-cyclone*. The disturbance in the cyclone is usually much greater than in the anti-cyclone.

At the centre of low pressure the barometer is low because at that place there is an ascending current of air, which rises until it reaches a great height, when it flows over into the surrounding regions. In the case of the area of high pressure there is a flow of air from the upper levels of the surrounding atmosphere into the centre of high pressure, thus raising the barometer.

It will be observed, also, that while the air in an area of low or high pressure may be only three or four miles high, these areas are hundreds of miles across.

Now it has been found that within the tropics, in the trade-wind zones, the drift of the atmosphere is towards the west and south, and disturbances are infrequent; but in higher latitudes the general drift is eastward, and disturbances are of frequent occurrence, especially during the colder months. Thus in Canada and the

*Greek, *isos* = equal, *baros* = weight.

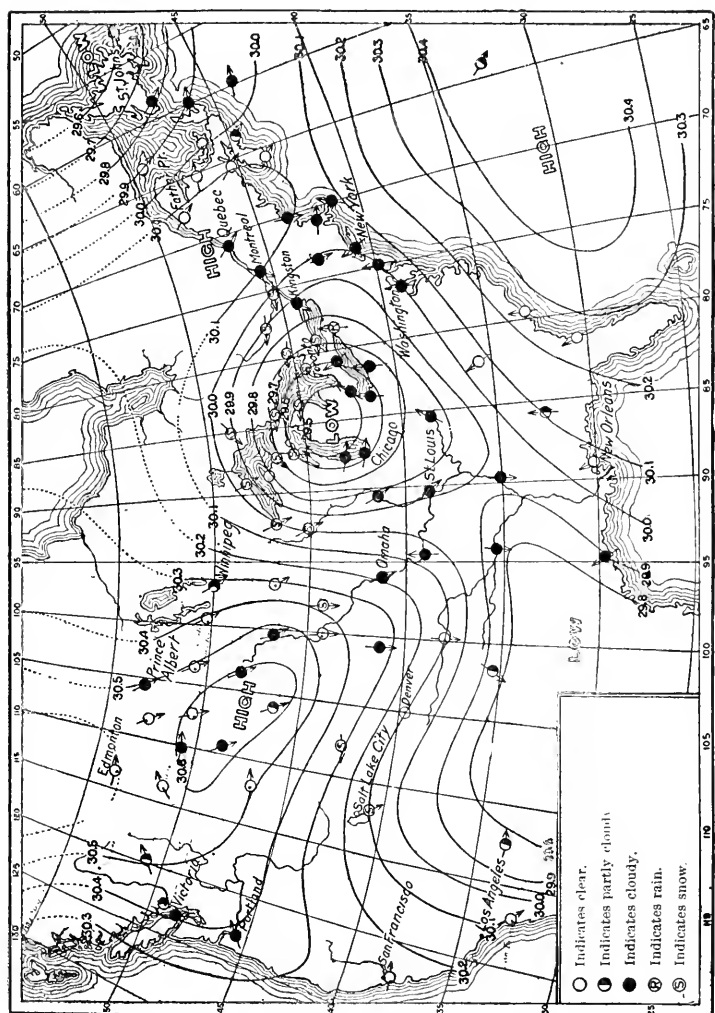

FIG. 135. — Weather Map issued at Toronto for 6 p.m., February 15th, 1910. The curved lines called isobars join places where the height of the barometer is the same. The arrows show the direction of the wind.

Note.—The storm indicated in the area of LOW pressure, at the centre of the map, developed during February 14th over the extreme northwestern States and moved southeast to Nebraska, where it was centred on the night of the 14th. It then moved in a more easterly direction, and at the time of the map was centred in the State of Michigan, whence it moved eastward along the St. Lawrence Valley. The HIGH to the west of it, extended to the Yukon Territory and Mackenzie River Valley.

Forecast.—Light snowfall with strong east winds during night of 15th, followed on the morning of 16th by strong northwest winds, and a change to much colder weather.

United States the areas of high and low pressure move eastward; the latter, however, travel faster than the former.

125. Elementary Principles of Forecasting. In using the weather map the chief aim is to foresee the movement of the areas of high and low pressure, and to predict their positions at some future time, say 36 hours hence. It is also essential to judge rightly what changes will occur in the energy of the areas shown on the map, as these changes will intensify or otherwise modify the atmospheric conditions.

As the cyclone moves eastward, the first indication of its approach will be the shifting of the wind to the eastward. The direction in which the wind will veer depends on whether the storm centre passes to the northward or the southward; and the strength of the wind will depend on the closeness of the isobars. If they are close together, the wind will be strong. If the centre passes nearly over a place, the wind will chop round to the westward very suddenly; while if the centre is at a considerable distance the change will be more gradual.

The precipitation (rain or snow) in connection with a cyclonic area is largely dependent on the energy of the disturbance, and on the temperature and moisture of the air towards which the centre is advancing. It must, of course, be remembered that rain cannot fall unless there is moisture, and moisture will not be precipitated unless the volume of the air containing it is cooled below the dew-point (§ 295). This cooling is caused by the expansion of the air as it ascends.

Occasionally we have a rain with a northerly wind succeeding the passage of a centre of low pressure. In this case the colder and heavier air flows in under the warmer air, lifting it to a height sufficient to cause the condensation of its moisture.

The duration of precipitation, and of winds of any particular direction, depends on the rate of movement of the storms and of the areas of high pressure. Temperature changes in any given region can be arrived at only by an accurate estimation of the distance and direction from which the air which passes over has been transferred by wind movement.

Abnormally warm weather results from the incoming of warm air from more southern latitudes; and cold waves do not develop in lower middle latitudes (such as Ontario), but are the result of the rapid flow southward of air which has been cooled in high latitudes.

126. Determination of Elevation. Since the pressure of the air decreases gradually with increase in height above the sea-level, it is evident that the barometer may be utilized to determine changes in elevation. If the density of the air were uniform, its pressure, like that of liquids, would vary directly as the depth. But on account of the compressibility of air, its density is not uniform. The lower layers, which

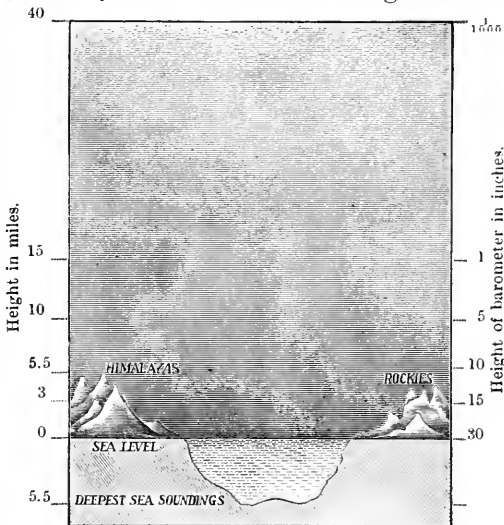

FIG. 136.—Atmospheric pressure at different heights.

sustain the greater weight, are denser than those above them. For this reason the law giving the relation between the barometric pressure and altitude is somewhat complex. For small elevations it falls at an approximately uniform rate of one inch for every 900 feet of elevation. Fig. 136 shows roughly the conditions of atmospheric pressure at various heights.

127. The Height of the Atmosphere. We have no means of determining accurately the height of the atmosphere. Twilight effects indicate a height of about fifty miles; above this the air ceases to reflect light. But it is known that air must extend far beyond this limit. Meteors, which consist of small masses of matter, made incandescent by the heat produced by friction with the atmosphere, have been known to become visible at heights of over 100 miles.

128. Compressibility and Expansibility of Air. We have already referred to the well-known fact that air is



FIG. 137.—
Air compressed
within a closed
tube by pressure
applied to piston.

compressible. Experiments might be multiplied indefinitely to show that the volume of air, or of any gas, is decreased by pressure. The air within a hollow rubber ball may be compressed by the hand. If a tightly-fitting piston be inserted into a tube closed at one end (Fig. 137) the air may be so compressed as to take up but a small fraction of the space originally occupied by it.

Again, if mercury is poured into a U-tube closed at one end (Fig. 138) it will be found that the higher the column of the mercury in the open branch, that is, the greater the pressure due to the weight of the mercury, the less the volume of the air shut up in the closed branch becomes.



FIG. 138.—
Air compressed
within a closed
tube by weight
of mercury in
the long
branch.

On the other hand gases manifest, under all conditions, a tendency to expand.

Whenever the pressure to which a given mass of air is subjected is lessened, its

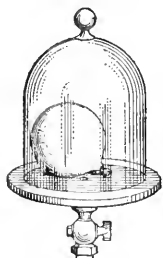

FIG. 139.—Expansion of
air when pressure is
removed.

volume increases. The compressed rubber ball takes its original volume and shape when the hand is withdrawn, and when the applied force is removed the piston shoots outwards. If a toy balloon, partially



FIG. 140.—Water forced
out of the closed bottle
by the expansion of
the air above it.

filled with air, is placed under the receiver of an air-pump (Fig. 139) and the air is exhausted from the receiver, the balloon swells out and if its

walls are not strong it bursts. When a bottle partly filled with water, closed with a perforated cork, and connected by a bent tube with an uncorked bottle, as shown in Fig. 140, is placed under the receiver of the air-pump, and the air exhausted from the receiver, the water is forced into the open bottle by the pressure of the air shut up within the corked bottle. This tendency of the air to expand explains why frail hollow vessels are not crushed by the pressure of the air on their outer walls. The pressure of the air within counterbalances the pressure of the air without.

QUESTIONS AND PROBLEMS

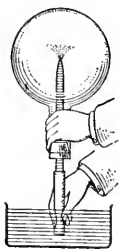

FIG. 141.



FIG. 142.

1. Arrange apparatus as shown in Fig. 141. By suction remove a portion of the air from the flask, and keeping the rubber tube closed by pressure, place the open end in a dish of water. Now open the tube. Explain the action of the water.

2. Guericke took a pair of hemispherical cups (Fig. 142) about

1.2 ft. in diameter, so constructed that they formed a hollow air-tight sphere when their lips were placed in contact, and at a test at Regensburg before the Emperor Ferdinand III and the Reichstag in 1654 showed that it required sixteen horses (four pairs on each hemisphere), to pull the hemispheres apart when the air was exhausted by his air-pump. Account for this.

3. If an air-tight piston is inserted into a cylindrical vessel and the air exhausted through the tube (Fig. 143) a heavy weight may be lifted as the piston rises. Explain this action.

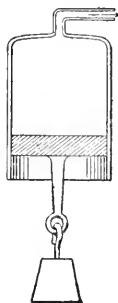

FIG. 143.

129. The Relation between the Volume and the Pressure of Air—Boyle's Law. The exact relation between the volume of a given mass of gas and the pressure upon it was first

determined by Robert Boyle (1627-1691), born at Lismore Castle, Ireland, who devoted a great deal of attention to the study of the mechanics of the air. In endeavouring to show that the phenomenon of the Torricellian experiment is explained by "the spring of the air," he hit upon a method of investigation which confirmed the hypothesis he had made, that the volume of a given quantity of air varies inversely as the pressure to which it is subjected. He took a U-tube of the form shown in Fig. 144, and by pouring in enough mercury to fill the bent portion, inclosed a definite portion of air in the closed shorter arm. By manipulating the tube he



FIG. 144.—Boyle's apparatus.



ROBERT BOYLE (1627-1691). Published his Law in 1662. One of the earliest of English scientists basing their investigations upon experiment.

adjusted the mercury so as to stand at the same height in each arm. Under these conditions the imprisoned air was at the pressure of the outside atmosphere, which at the time of the experiment would support a column of mercury about 29 inches high. He then poured mercury into the open arm until the air in the closed arm was compressed into one-half its volume. "We observed," he says, "not without delight and satisfaction, that the quicksilver in that longer part of the tube was 29 inches higher than the other." This difference in level gave the excess of pressure of the inclosed air over that of the outside atmosphere. It was

clear to him, therefore, that the pressure sustained by the inclosed air was doubled when the volume was reduced to one-half. Continuing his experiment, he showed, on using a great variety of volumes and their corresponding pressures, that the product of the pressure by the volume was approximately a constant quantity. His conclusion may be stated in general terms thus:—

Let V_1, V_2, V_3 , etc., represent the volumes of the inclosed air, and P_1, P_2, P_3 , etc., represent corresponding pressures;

Then $V_1 P_1 = V_2 P_2 = V_3 P_3 = K$, a constant quantity.

That is,

If the temperature is kept constant, the volume of a given mass of air varies inversely as the pressure to which it is subjected. This relation is generally known as BOYLE'S LAW. In France it is called Mariotte's Law, because it was independently discovered by a French physicist named Mariotte (1620-1684), fourteen years after Boyle's publication of it in England.

PROBLEMS

1. A tank whose capacity is 2 cu. ft. has gas forced into it until the pressure is 250 pounds to the sq. inch. What volume would the gas occupy at a pressure of 75 pounds to the sq. inch?

2. A gas-holder contains 22.4 litres of gas when the barometer stands at 760 mm. What will be the volume of the gas when the barometer stands at 745 mm.?

3. A cylinder whose internal dimensions are: length 36 in., diameter 14 in., is filled with gas at a pressure of 200 pounds to the sq. inch. What volume would the gas occupy if allowed to escape into the air when the barometer stands at 30 in.? (For density of mercury see page 14.)

4. Twenty-five cu. ft. of gas, measured at a pressure of 29 in. of mercury, is compressed into a vessel whose capacity is $1\frac{1}{2}$ cu. ft. What is the pressure of the gas?

5. A mass of air whose volume is 150 c.c. when the barometer stands at 750 mm. has a volume of 200 c.c. when carried up to a certain height in a balloon. What was the reading of the barometer at that height?

6. A piston is inserted into a cylindrical vessel 12 in. long, and forced down within 2 in. of the bottom. What is the pressure of the inclosed air if the barometer stands at 29 in.?

7. The density of the air in a gas-bag is 0.001293 grams per c.c. when the barometer stands at 760 mm.; find its density when the barometric height is 740 mm.?

8. An open vessel contains 100 grams of air when the barometer stands at 745 mm. What mass of air does it contain when the barometer stands at 755 mm.?

9. Oxygen gas, used for the 'lime-light,' is stored in steel tanks. The volume of a tank is 6 cu. ft., and the pressure of the gas at first was 15 atmospheres. After some had been used the pressure was 5 atmospheres. If the gas is sold at 6 cents a cu. ft., measured at atmospheric pressure, what should be charged for the amount consumed?

130. Buoyancy of Gases. If we consider the cause of buoyancy we must recognize that Archimedes' principle applies to gases as well as to liquids. If a hollow metal or glass globe *A* (Fig. 145), suspended from one end of a short balance beam and counterpoised by a small weight *B* at the other end, is placed under the receiver of an air-pump and the air exhausted from the receiver, the globe is seen to sink. It is evident, therefore, that it was supported to a certain extent by the buoyancy of the air.

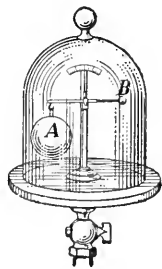

FIG. 145.—Buoyancy of air.

A gas, like a liquid, exerts on any body immersed in it, a buoyant force which is equal to the weight of the gas displaced by the body. If a body is lighter than the weight of the air equal in volume to itself, it will rise in the air, just as a cork, let free at the bottom of a pail of water, rises to the surface.

131. Balloons. The use of air-ships or balloons is made possible by the buoyancy of the air. A balloon is a large, light, gas-tight bag filled with some gas lighter than air, usually hydrogen or illuminating gas. Fig. 146 shows the construction of an air-ship devised by Count Zeppelin in Germany. By means of propellers it can be driven in any desired direction.

A balloon will continue to rise so long as its weight is less than the weight of the air which it displaces, and when there

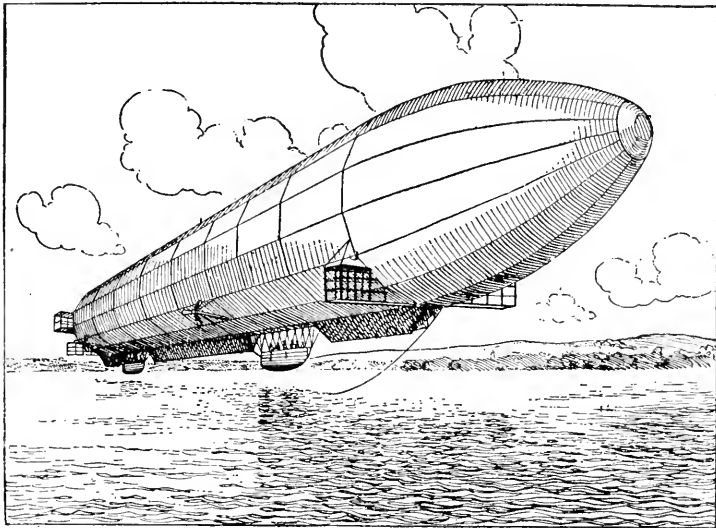

FIG. 146.—Zeppelin's air-ship, over 400 ft. long and able to carry 30 passengers.

is a balance between the two forces it simply floats at a constant height. The aeronaut maintains his position by adjusting the weight of the balloon to the buoyancy of the air. When he desires to ascend he throws out ballast. To descend he allows gas to escape and thus decreases the buoyancy.

QUESTIONS AND PROBLEMS

1. Why should the gas-bag be subject to an increased strain from the pressure of the gas within as the balloon ascends?
2. Aeronauts report that balloons have greater buoyancy during the day when the sun is shining upon them than at night when it is cold. Account for this fact.
3. If the volume of a balloon remains constant, where should its buoyancy be the greater, near the earth's surface or in the upper strata of the air? Give reasons for your answer.
4. The volume of a balloon is 2500 cu. m. and the weight of the gas-bag and car is 100 kg.; find its lifting power when filled with hydrogen gas, the density of which is 0.0000895 grams per c.c. while that of air is 0.001293 grams per c.c.

CHAPTER XIV

APPLICATIONS OF THE LAWS OF GASES

132. Air-Pump. Fig. 147 shows the construction of one of the most common forms of pumps used for exhausting air

from a vessel. When the piston P is raised, the valve V_1 is closed by its own weight and the pressure of the air above it. The expansive force of the air in the receiver lifts the valve V_2 and a portion of the air flows into the lower part of the barrel.

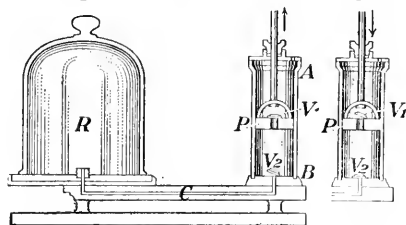

FIG. 147.—Common form of air-pump. AB , cylindrical barrel of pump; R , receiver from which air is to be exhausted; C , pipe connecting barrel with receiver; P , piston of pump; V_1 and V_2 , valves opening upwards.

When the piston descends, the valve V_2 is closed and the air in the barrel passes up through the valve V_1 . Thus at each double stroke, a fraction of the air is removed from the receiver. The process of exhaustion will cease when the expansive force of the air in the receiver is no longer sufficient to lift the valve V_2 , or when the pressure of the air below the piston fails to lift the valve V_1 . It is evident, therefore, that a partial vacuum only can be obtained with a pump of this kind. To secure more complete exhaustion, pumps in which the valves are opened and closed automatically by the motion of the piston are frequently used, but even with these all the air cannot be removed from the receiver. Theoretically, a perfect vacuum cannot be obtained in this way, because at each stroke the air in the receiver is reduced only by a *fraction of itself*.

133. The Geryk or Oil Air-Pump. This is a very efficient pump recently invented but widely used. (Figs. 148, 149.) Its

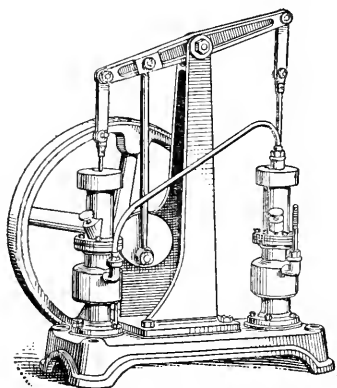

FIG. 148.—An oil air-pump with two cylinders.

action is as follows. The piston *J*, made air-tight by the leather washer *C* and by being covered with oil, moves up-and-down in the barrel. The tube *A*, opening into the chamber *B* surrounding the barrel, is connected to the vessel from which the air is to be removed. On rising the piston pushes before it the air in the barrel, and on reaching the top it pushes up *G* about $\frac{1}{4}$ inch, thus allowing the imprisoned air to escape through the oil into the

upper part of the cylinder, from which it passes out by the tube *D*.

When the piston descends the spring *K*, acting upon the packing *I*, closes the upper part of the cylinder, and the piston on reaching the bottom drives whatever oil or air is beneath out through the tube *F*, or allows it to go up through the valve *E*, into the space above the piston.

Oil is introduced into the cylinder at *L*. When the pump has two cylinders they are connected as shown in Fig. 149. With one cylinder the pressure of the air can be reduced to $\frac{1}{4}$ mm. of mercury, while with two a reduction to $\frac{1}{5000}$ mm. can be quickly obtained. These pumps are used for exhausting electric light bulbs and in some cases for X-ray tubes.

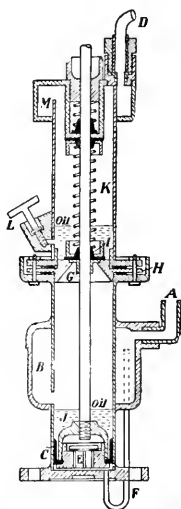

FIG. 149.—Vertical section of a cylinder of an oil air-pump.

134. Mercury Air-Pump. When the vacuum is required, use is made of some form of the mercury air-pump devised by Sprengel. The principle of its action may be understood by reference to Fig. 150. As the mercury which is poured into the reservoir *A* falls in a broken stream through the nozzle *N* into the tube *B*, it carries air with it because each pellet of mercury acts as an air-tight piston and bears a small portion of air before it. The density of the air in *C* and *R* is thus gradually decreased. The mercury which overflows into *D* is poured back into *A*. A vacuum as high as 0.000,007 mm. has been obtained with a mercury pump. It requires a good pump of the valved type to give an exhaustion of 1 mm.

highest possible

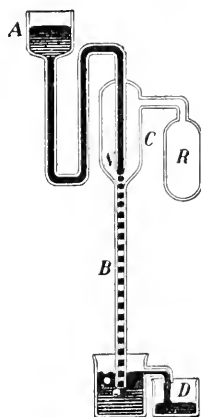

Fig. 150. — Sprengel air-pump. *A*, reservoir into which mercury is poured. *B*, glass tube of small bore, about one metre long; *R*, vessel from which air is to be drawn.

135. Bunsen Jet Pump.

Bunsen devised a simple and convenient form of pump, which is much used in laboratories where a moderate exhaustion is required, as for hastening the process of filtration. In this pump (Fig. 151) water under a pressure of more than one atmosphere is forced into a jet through a tube nozzle *N*. The air is carried along by the water and is thus withdrawn from any vessel connected with the offset tube *A*.

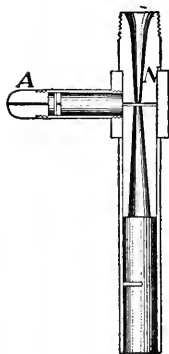

Fig. 151.—Bunsen jet pump.

136. The Hydraulic Air-Compressor. An application of the principle involved in the instruments just described is to be seen in the great air-compressor at Ragged Chutes,

on the Montreal River, eight miles south-west from Cobalt, the centre of the great mining region in northern Ontario.

A cement dam 660 feet long across the river raises the level of the water. By a large tube *A* (Fig. 152) the water is led

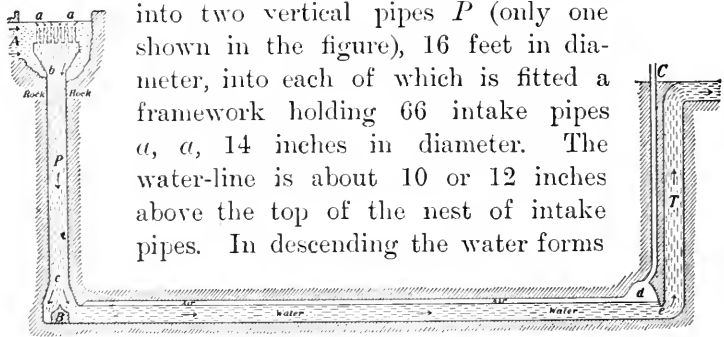

FIG. 152.—Taylor air-compressor at Ragged Chutes on Montreal River (section).

a vortex in the mouth of each pipe through which air is drawn down into the shaft below. Thus air and water are mixed together. At *b* the pipe is reduced to 9 feet and near the bottom, at *c*, is enlarged to 11½ feet in diameter.

The water drops 350 feet, falling on a steel-covered cone *B*, from which it rushes into a horizontal tunnel over 1000 feet long, the farther end *d* of which is 42 feet high. In this large channel the water loses much of its speed and the air is rapidly set free, collecting in the upper part of the tunnel. At *e* the tunnel narrows and the water races past and enters the tail-shaft *T*, 300 feet high, from which it flows into the river again.

The air entrapped in the tunnel is under a pressure due to about 300 feet of water, or about 125 pounds per square inch. From *d* a 24-inch steel pipe leads to the surface of the earth and from here the compressed air is piped off to the mines.

Other air-compressors on the same principle are to be found at Magog, Quebec; at Ainsworth, B.C.; at the lift-lock at Peterborough (see § 97); and at the Victoria Mines in Michigan; but the one near Cobalt is the largest in existence.

137. Air Condenser. It is obvious that the air-pump could be used as an air-compressor or condenser if the valves were made to open inwards instead of outwards; but a pump with a solid piston is commonly employed for this purpose. Fig. 153 shows the arrange-

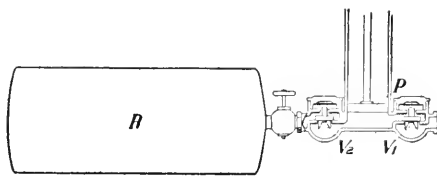

FIG. 153.—Air-compressor. *P*, piston; *R*, tank or receiver; V_1 inlet valve; V_2 , outlet valve.

ment of the valves. When the piston is raised, the inlet valve V_1 opens and the barrel is filled with air from the outside, and when the piston is pushed down the inlet valve is closed and the air is forced into the tank through the outlet valve V_2 , which closes on the up-stroke and thus retains the air within the tank. Hence at each double stroke a barrelful of air is forced into the tank. For rapid compression a double-action pump of the form shown in Fig. 159 is used.

EXERCISE.—Obtain a small bicycle pump, take it apart, and study its construction and action.

138. Uses of Compressed Air. The air-brakes and diving apparatus are described in the next two sections. Another useful application is the pneumatic drill, used chiefly for boring holes in rock for blasting. In it the steel drill is attached to a piston which is made to move back and forth in a cylinder by allowing compressed air to act alternately on its two faces. The pneumatic hammer, which is similar in principle, is used for riveting and in general foundry work. Steam could be used, but the pipes conveying it would be hot and water would be formed from it. By means of a blast of sand, projected by a jet of air, castings and also discoloured stone and brick walls are cleaned. Figures on glass are engraved in the same way. Tubes for transmitting letters or telegrams, or for carrying cash in our large retail stores, are operated by compressed air. Many other applications cannot be mentioned here.

139. Air-Brakes. Compressed air is used to set the brakes on railway cars. Fig. 154 shows the principal working parts of the Westinghouse air-brakes in common use in this country. A steam-driven air-compressor pump *A* and a tank *B* for compressed air are attached to the locomotive. The equipment on each car consists of (*a*) a cylinder *C* in which works a piston *P* directly connected, by a piston-rod *D* and a system of levers,

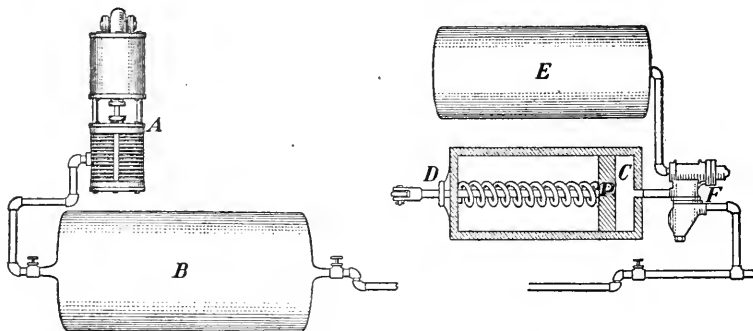

FIG. 154.—Air brakes in use on railway trains.

with the brake-shoe, (*b*) a secondary tank *E*, and (*c*) a system of connecting pipes and a special valve *F* which automatically connects *B* with *E* when the air from *B* is admitted to the pipes, but which connects *E* with the cylinder *C* when the pressure of the air is removed.

When the train is running, pressure is maintained in the pipes, and the brakes are free, but when the pressure is decreased either by the engineer or the accidental breaking of a connection, the inrush of air from *E* to *C* forces the piston *P* forward and the brakes are set. To take off the brakes, the air is again turned into the pipes when *B* is connected with *E* and the air in *C* is allowed to escape, while the piston *P* is forced into its original position by a spring.

140. Diving Bells and Diving Suits. Compressed air is also used as a reserve supply for individuals cut off from the atmosphere, as in the case of men engaged in submarine

work. The diving bells and pneumatic caissons used in laying the foundations of bridges, piers, etc., are simply vessels of various shapes and sizes, open at the bottom, from which the water is kept out and workmen within supplied with air by compressed air forced in through pipes from above. (Fig. 155.) The air fills the tank completely, thus excluding the water, and escapes at the lower edges.

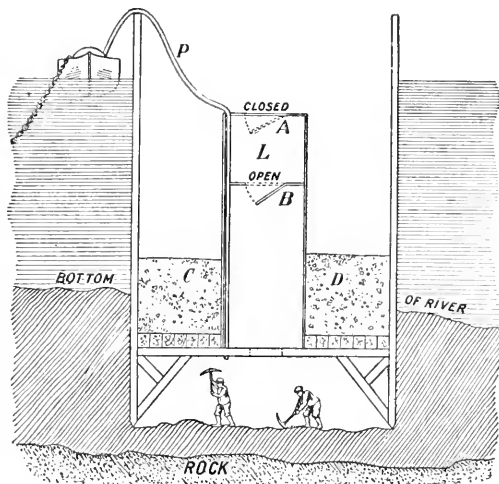

FIG. 155.—Section of a Pneumatic Caisson. The sides of the caisson are extended upward and are strongly braced to keep back the water. Masonry or concrete, *C, D*, placed on top of the caisson, press it down upon the bottom, while compressed air, forced through a pipe *P*, drives the water out of the working chamber. To leave the caisson the workman climbs up and passes through the open door *B* into the air-lock *L*. The door *B* is then closed and the air is allowed to escape from *L* until it is at atmospheric pressure. Then door *A* is opened. In order to enter, this process is reversed. Material is hoisted out in the same way or is sucked out by a mud pump. As the earth is removed the caisson sinks until the rock is reached. The entire caisson is then filled with solid concrete, and a permanent foundation for a dock or bridge is thus obtained.

The modern diver is incased in an air-tight weighted suit. (Fig. 156.) He is supplied with air from above through pipes or from a compressed-air reservoir attached to his suit. The air escapes through a valve into the water. Manifestly the pressure of the air used by a diver or a workman in a caisson must balance the pressure of the outside air, and the pressure of the water at his depth. The deeper he descends, therefore, the greater the pressure to which he is subjected. The ordinary limit of safety is about 80 feet; but divers have worked at depths of over 200 feet.



FIG. 156.—Diver's suit.

141. Water Pumps. From very early times pumps were employed for raising water from reservoirs, or for forcing it through tubes. It is certain that the suction pump was in use in the time of Aristotle (born 384 B.C.). The force-pump was probably the invention of Ctesibius, a mechanician who flourished in Alexandria in the second century B.C. To Ctesibius is also attributed the ancient fire-engine, which consisted of two connected force-pumps, spraying alternately.

142. Suction or Lift-Pump. The construction of the common suction-pump is shown in Fig. 157. During the first

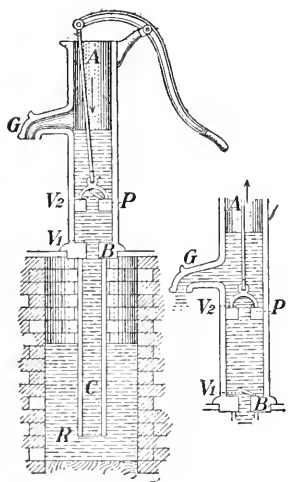

FIG. 157.—Suction-pump. *AB*, cylindrical barrel; *BC*, suction-pipe; *P*, piston; *V*₁ and *V*₂, valves opening upwards; *R*, reservoir from which water is to be lifted.

strokes the suction-pump acts as an air-pump, withdrawing the air from the suction pipe *BC*. As the air below the piston is removed its pressure is lessened, and the pressure of the air on the surface of the water outside forces the water up the suction pipe, and through the valve *V*₁ into the barrel. On the down-stroke the water held in the barrel by the valve *V*₁ passes up through the valve *V*₂, and on the next up-stroke it is lifted up and discharged through the spout *G*, while more water is forced up through the valve *V*₁ into the barrel by the external pressure of the atmosphere. It is evident that the maximum height to which water, under perfect conditions,

is raised by the pressure of the atmosphere cannot be greater than the height of the water column which the air will support. Taking the relative density of mercury as 13.6 and the height of the mercury barometer as 30 inches, this

height would be $\frac{3}{2} \times 13.6 = 34$ feet. But an ordinary suction-pump will not work satisfactorily for heights above 25 feet.

143. Force-Pump. When it is necessary to raise water to a considerable height, or to drive it with force through a nozzle, as for extinguishing fire, a force-pump is used. Fig. 158 shows the most common form of its construction. On the up-stroke a partial vacuum is formed in the barrel, and the air in the suction tube expands and passes up through the valve V_1 . As the plunger is pushed down the air is forced out through the valve V_2 . The pump, therefore, during the first strokes acts as an air-pump. As in the suction-pump, the water is forced up into the suction pipe by the pressure of the air on the surface of the water in the reservoir. When it enters the barrel it is forced by the plunger at each down-stroke through the valve V_2 into the discharge pipe. The flow will obviously be intermittent, as the outflow takes place only as the plunger is descending. To produce a continuous stream, and to lessen the shock on the pipe, an air chamber, F is often inserted in the discharge pipe. When the water enters this chamber it rises above the outlet G which is somewhat smaller than the inlet, and compresses the air in the chamber. As the plunger is ascending the pressure of the inclosed air forces the water out of the chamber in a continuous stream.

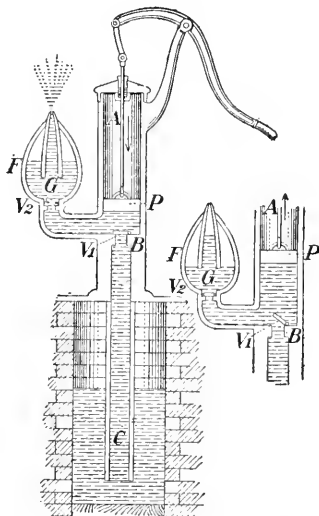

FIG. 158—Force-pump. AB , cylindrical barrel; BC , suction-pipe; P , piston; F , air chamber; V_1 , valve in suction-pipe; V_2 , valve in outlet pipe; G , discharge pipe; R , reservoir from which water is taken.

144. Double Action Force-Pump. In Fig. 159 is shown the construction of the double-action force-pump. When the

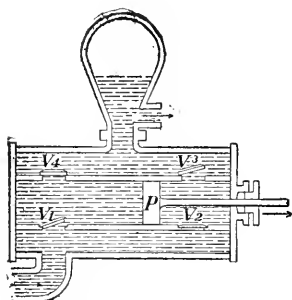

FIG. 159.—Double-action force-pump.
P, piston; *V*₁, *V*₂, inlet valves; *V*₃,
*V*₄, outlet valves.

piston is moved forward in the direction of the arrow, water is drawn into the back of the cylinder through the valve *V*₁, while the water in front of the piston is forced out through the valve *V*₃. On the backward stroke water is drawn in through the valve *V*₂ and is forced out through the valve *V*₄. Pumps of this type are used as fire engines, or for any

purposes for which a large continuous stream of water is required. They are usually worked by steam or other motive power.

QUESTIONS AND PROBLEMS

1. The capacity of the receiver of an air-pump is twice that of the barrel; what fractional part of the original air will be left in the receiver after (a) the first stroke, (b) the third stroke?

2. The capacity of the barrel of an air-pump is one-fourth that of the receiver; compare the density of the air in the receiver after the first stroke with the density at first.

3. The capacity of the receiver of an air-compressor is ten times that of the barrel; compare the density of the air in the receiver after the fifth stroke with its density at first.

4. How high can alcohol be raised by a lift-pump when the mercury barometer stands at 760 mm. if the relative densities of alcohol and mercury are 0.8 and 13.6 respectively?

5. Connect a glass model pump with a flask, as shown in Fig. 160. Fill the flask (a) full, (b) partially full of water, and endeavour to pump the water. Account for the result in each case.

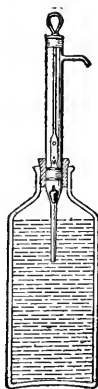

FIG. 160.

145. Siphon. If a bent tube is filled with water, placed in a vessel of water and the ends unstopped, the water will flow freely from the tube, so long as there is a difference in level in the water in the two vessels. A bent tube of this kind used to transfer a liquid from one vessel to another at a lower level is called a siphon.

To understand the cause of the flow consider Fig. 161.

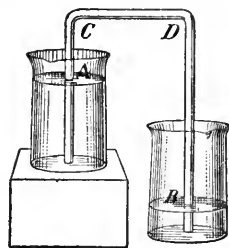

FIG. 161.—The siphon.

The pressure at *A* tending to move the water in the siphon in the direction *AC*

= the atmospheric pressure — the pressure due to the weight of the water in *AC*;

and the pressure at *B* tending to move the water in the siphon in the direction *BD*

= the atmospheric pressure — the pressure due to the weight of the water in *BD*.

But since the atmospheric pressure is the same in both cases, and the pressure due to the weight of the water in *AC* is less than that due to the weight of the water in *BD*, the force tending to move the water in the direction *AC* is greater than the force tending to move it in the direction *BD*; consequently a flow takes place in the direction *ACDB*. This will continue until the vessel from which the water flows is empty, or until the water comes to the same level in each vessel.

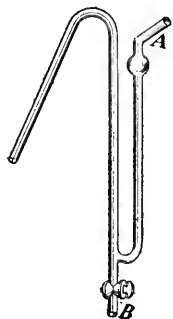

FIG. 162.—The aspirating siphon.

146. The Aspirating Siphon. When the liquid to be transferred is dangerous to handle, as in the case of some acids, an aspirating siphon is used. This consists of an ordinary siphon to which is attached an offset tube and

stopcock, as shown in Fig. 162, to facilitate the process of filling. The end *B* is closed by the stopcock and the liquid is drawn into the siphon by suction at the mouth-piece *A*. The stopcock is then opened and the flow begins.

QUESTIONS AND PROBLEMS

1. Upon what does the limit of the height to which a liquid can be raised in a siphon depend?

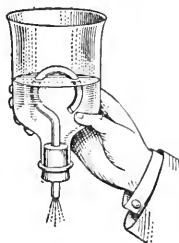

FIG. 163.

2. Over what height can (a) mercury, (b) water, be made to flow in a siphon?

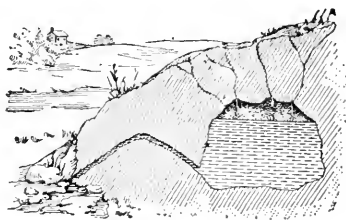

FIG. 164.—An intermittent spring.

3. How high can sulphuric acid be raised in a siphon when the mercury barometer stands at 29 in., taking the specific gravities of sulphuric acid and mercury as 1.8 and 13.6 respectively?

4. Upon what does the rapidity of flow in the siphon depend?

5. Arrange apparatus as shown in Fig. 163. Let water from a tap run *slowly* into the bottle. What takes place? Explain.

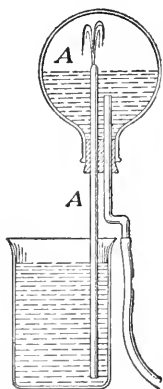

FIG. 165.

6. Natural reservoirs are sometimes found in the earth, from which the water can run by natural siphons faster than it flows into them from above (Fig. 164). Explain why the discharge through the siphon is intermittent.

7. Arrange apparatus as shown in Fig. 165. Fill the flask *A* partly full of water, insert the cork, and then invert, placing the short tube in water. Explain the cause of the phenomenon observed.

PART IV—SOME PROPERTIES OF MATTER

CHAPTER XV

THE MOLECULAR THEORY OF MATTER

147. Why we make Hypotheses. In order to account for the observed behaviour of bodies the human mind finds satisfaction in making hypotheses as to the manner in which material bodies are built up. In this way we attempt to “explain” and to trace a connection between various natural phenomena. But it must be remembered that our hypotheses are only methods of picturing to ourselves what we know of the behaviour of substances. Of the *real* nature of matter we still remain in complete ignorance.

We are all familiar with matter in its three ordinary forms—solid, liquid, gaseous—and a multitude of observations have led to the universal belief that it is composed of minute separate particles. These particles are called *molecules*. The molecules of some elements and of compound substances can be still further divided into *atoms*, but in this way the nature of the substance is altered,—in other words this is not a physical subdivision but a chemical change. Thus, the oxygen molecule has two atoms, and the water molecule consists of two atoms of hydrogen and one of oxygen.

148. Evidence suggesting Molecules. Water will soak into wood, or into beans, peas or other such seeds. On mixing 50 c.c. of water with 50 c.c. of alcohol the resulting

volume is not 100 c.c., but only about 97 c.c. When copper and tin are mixed in the ratio of 2 of copper to 1 of tin, which gives an alloy used for making mirrors of reflecting telescopes, there is a shrinkage in volume of 7 or 8 per cent.

Again, various gases may be inclosed in the same space, and gases may be contained in liquids. Fish live by the oxygen which is dissolved in the water.

A simple explanation of these phenomena is that all bodies are made up of molecules with spaces between, into which the molecules of other bodies may enter. As we shall see, the molecules and the spaces between are much too small to be observed with our most powerful microscopes. The magnifying power would have to be increased several thousand times, but even though this requisite magnification were obtained it is probable that the molecules could not then be seen, since there are good grounds for believing that they are constantly moving so rapidly that the eye could not follow them.

That there are pores or channels between the molecules was neatly proved by Bacon,* who filled a leaden shell with water, closed it, and then hammered it, hoping to compress the water within. But the water came through, appearing on the outside like perspiration. Afterwards the scientists of Florence tried the experiment with a silver shell, and also with the same shell thickly gilded over, but in both cases the water escaped in the same way. Many other illustrations of porosity could be given.†

*Francis Bacon, 1561-1626.

†See Tail's "Properties of Matter," §§ 98-100.

149. Diffusion of Gases. The intermingling of molecules is best illustrated in the behaviour of gases. In order to investigate this question the French chemist, Berthollet, used apparatus like that illustrated in Fig. 166. It consisted of two glass globes provided with stopcocks, which could be securely screwed together. The upper one was filled with hydrogen and the lower with carbonic acid gas which is 22 times as dense. They were then screwed together, placed in the cellar of the Paris Observatory and the stopcocks opened. After some time the contents of the two globes were tested and found to be identical,—the gases had become uniformly mixed.

When the passage connecting the two vessels is small, hours may be required for perfect mixing; but when it is large a few minutes will suffice.

A simpler experiment on diffusion is the following. Fill one wide-mouthed jar with hydrogen and a similar one with oxygen, which is 16 times as heavy, covering the vessels with glass plates. Then put them together as shown in Fig. 167 and withdraw the glass plates. After allowing them to stand for some minutes separate them and apply a match. At once there will be a similar explosion from each, showing that the two gases have become thoroughly mixed.*

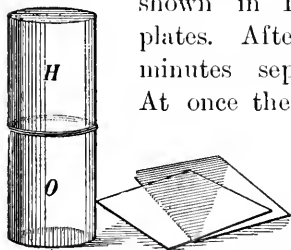

FIG. 167.—Hydrogen in one vessel quickly mixes with oxygen in the other.

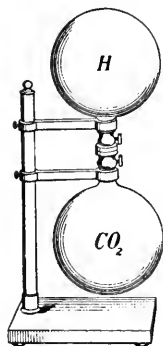

FIG. 166.—Two glass globes, one filled with hydrogen, the other with carbonic acid gas. The two gases mix until the contents of the two globes are identical.

there is no excess of it at low levels.

* In performing this experiment wrap a cloth about each jar for safety.

150. Diffusion of Liquids and Solids. Liquids diffuse into each other, though not nearly so rapidly as do gases.

If coloured alcohol (density 0.8) is carefully poured on the top of clear water in a tumbler (or if water be introduced under the alcohol), the mixing of the two will be seen to commence at once and will proceed quite rapidly.



FIG. 168.—Copper sulphate solution in a bottle, placed in a vessel of water. In time the blue solution spreads all through the water.

Let a wide-mouthed bottle *a* (Fig. 168) be filled with a solution of copper sulphate and then placed in a larger vessel containing clear water. The solution is denser than the water but in time the colour will be distributed uniformly throughout the liquid.

Diffusion takes place also in some metals, though very slowly at ordinary temperatures. Roberts-Austen found that the diffusion of gold through lead, tin and bismuth at 550° C. was very marked; and that even at ordinary temperatures there was an appreciable diffusion of gold through solid lead. In his experiments discs of the different metals were kept in close contact for several weeks.

151. Motions of the Molecules; the Kinetic Theory. An explanation of such results as these is the hypothesis that all bodies are made up of molecules which have considerable freedom of motion, especially so in the case of gases.

The laws followed by gases, which are much simpler than those of solids and liquids, are satisfactorily accounted for by these molecular motions.

The distinguishing feature of a gas is its power of indefinite expansibility. No matter what the size of the vessel is into which a certain mass of gas is put, it will at once spread out and occupy the entire space. The particles of a gas are practically independent of their neighbours, moving freely about in the enclosure containing the gas.

A gas exerts pressure against the walls of the vessel containing it. This can be well illustrated as follows. Place a toy balloon or a half-inflated football rubber under the receiver of an air-pump and work the pump. (Fig. 169.) As the air about the bag is continually removed the bag expands; and when the air is admitted again into the receiver the bag resumes its original volume.

We may consider the bag as the seat of two contending factions,—the troops of molecules within endeavouring to keep back the invading hosts of molecules without. Incessantly they rush back and forth, continually striking against the surface of the bag. As the enemies are withdrawn by the action of the pump, the defenders within gain the advantage and, pushing forward, enlarge their boundary, which at last however becomes so great that it is again held in check by the outsiders.

Or, we may compare the motion of the molecules of a gas to the motions of a number of bees in a closed vessel. They continually rush from side to side, frequently colliding with each other. The never-ceasing striking of the molecules of the gas against a body gives rise to the pressure exerted by the gas. This view of a gas is known as the Kinetic Theory.

152. Explanation of Boyle's Law. According to Boyle's Law (§ 129), when a gas is compressed to half its volume the pressure which it exerts against the walls of the vessel containing it is doubled. This is just what we would expect. When the gas is made to occupy a space half as large, the particles in that space will be twice as numerous, the blows against its sides will be twice as numerous as before, and consequently the pressure will be doubled.

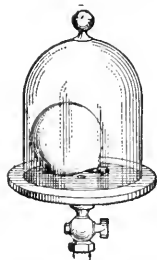

FIG. 169.—When the air is removed from the receiver the toy balloon expands.

153. Effect of a Rise in Temperature. If we place the rubber bag used in § 151 in an oven it expands, showing that the pressure of the gas is increased by the application of heat. Evidently when a gas is heated its molecules are made to move with greater speed, and this produces a greater pressure and causes the gas to expand.

154. Molecular Velocities. On account of numerous collisions the molecules will not all have the same velocity, but knowing the pressure which a gas exerts and also its density, it is possible to calculate the *mean* velocity of the molecules. In the following table the mean velocity,* at atmospheric pressure and freezing temperature, is given for some gases.

TABLE OF MOLECULAR VELOCITIES

Hydrogen	1843 m. or 6046 ft. per second.
Nitrogen	493 m. or 1618 ft. “
Oxygen	462 m. or 1517 ft. “
Carbon Dioxide	393 m. or 1291 ft. “

It will be seen that the hydrogen molecules move fastest of all, being about four times as rapid as the molecules of nitrogen and oxygen, the chief constituents of the atmosphere. This is because it is much lighter. Each gas, by means of the bombardment of its molecules, is able to produce a pressure as great as that of any other gas, and hence as hydrogen is much lighter its molecular velocity must be much higher. The velocity is inversely proportional to the square root of the density of the gas.

*Strictly speaking it is the square root of the mean square velocity which is given here.

155. Passage of Hydrogen through a Porous Wall. As the velocities of the hydrogen molecules are so great, they strike much more frequently against the walls of the vessel which contains them than do the molecules of other gases. Hence, it is harder to confine hydrogen in a vessel than another gas, and it diffuses more rapidly. This is well illustrated in the following experiment.

An unglazed earthenware cup, *A*, (such as is used in galvanic batteries) is closed with a rubber or other cork impervious to air, and a glass tube connects this with a bottle nearly full of water (Fig. 170). A small glass tube *B*, drawn to a point, also passes through the cork of the bottle and reaches nearly to the bottom of the bottle. A small glass tube *C*, drawn to a point, also passes through the cork of the bottle and reaches nearly to the bottom of the bottle.

Now hold over the porous cup a bell-jar full of dry hydrogen, or pass illuminating gas by the tube *C* into the bell-jar. Very soon a jet of water will spurt from the tube *B*, sometimes with considerable force. After this action has ceased remove the bell-jar, and bubbles will be seen entering the water through the lower end of the tube *B*.

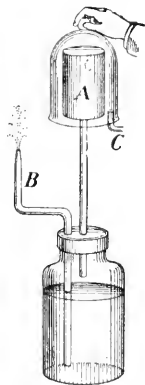

FIG. 170.—Experiment showing rapid passage of hydrogen through a porous wall.

At first the space within the porous cup and in the bottle above the water is filled with air, and when the hydrogen is placed about the porous cup its molecules pass in through the walls of the cup much faster than the air molecules come out. In this way the pressure within the cup is increased, and this, when transmitted to the surface of the water, forces it out in a jet. When the jar is removed the hydrogen rapidly escapes through the porous walls and the air rushing in is seen to bubble up through the water.

156. Molecular Motions in Liquids. In liquids the motions of the molecules are not so unrestrained as in a gas, but one can hardly doubt that the motions exist, however. Indeed, some direct evidence of these motions has been obtained. Brown, an English botanist, in 1827, with the assistance of a microscope, observed that minute particles like spores of plants when introduced into a fluid were always in a state of agitation, dancing to and fro in all directions with considerable speeds. The smaller the particle the greater was its velocity, and the motions were apparently due to these particles being struck by molecules of the liquid. More recently a method has been devised for demonstrating the presence of particles which are too small to be seen with a microscope, and by means of it the particles obtained on making an emulsion of gamboge in water (which are too small to be observed with a microscope) have been shown to have these same Brownian motions. It is natural to infer that these motions are caused by the movement of the molecules of the liquid.

The spaces between the molecules are much smaller than in a gas and so the collisions are much more frequent. Moreover the molecules exert an attractive force on each other, the force of cohesion, but they glide about from point to point throughout the entire mass of the liquid. Usually when a molecule comes to the surface its neighbours hold it back and prevent it from leaving the liquid. The molecules, however, have not all the same velocity, and occasionally when a quick-moving one reaches the surface the force of attraction is not sufficient to restrain it and it escapes into the air. We say the liquid *evaporates*.

When a liquid is heated the molecules are made to move more rapidly and the collisions are more frequent. The result is that the liquid expands and the evaporation is more rapid.

In the case of oils the molecules appear to have great difficulty in escaping at the surface, and so there is little evaporation.

157. Osmosis. Over the opening of a thistle-tube let us tie a sheet of moistened parchment or other animal membrane (such as a piece of bladder). Then, having filled the funnel and a portion of the tube with a strong solution of copper sulphate, let us support it as in Fig. 171 in a vessel of water so that the water outside is at the same level as the solution within the tube.

In a few minutes the solution will be seen to have risen in the tube. The water will appear blue, showing that some of the solution has come out, but evidently more water has entered the tube. The rise in level continues (perhaps for two or three hours) until the hydrostatic pressure due to the difference of levels stops it.

This mode of diffusion through membranes is called *osmosis*, and the difference of level thus obtained is called *osmotic pressure*.

Substances such as common salt and others which usually form in crystals are called *crystalloids*. These diffuse through membranes quite rapidly. Starch, gelatine, albumen and gummy substances generally, which are usually amorphous in structure, are called *colloids*. These diffuse very slowly.

Osmosis plays an important part in the processes of nature.

158. Molecular Motions in Solids. As has been stated in § 150, evidences of the diffusion of the molecules of one solid into another have been observed, but the effect is very slight.

If a lump of sugar is dropped into a cup of tea it soon dissolves, and in time its molecules spread to every part of the liquid, giving sweetness to it. In this instance the molecules of water enter into the lump of sugar and loosen the bonds

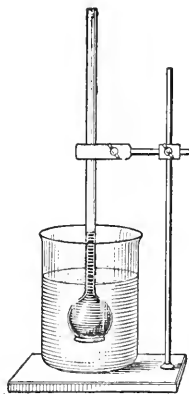

FIG. 171.—Osmosis.

which hold the molecules of sugar together. The molecules thus set free spread throughout the liquid.

Drop a minute piece of potassium permanganate into a quart jar full of water and shake the jar for a moment. The solid disappears and the water soon becomes of a rich red colour, showing that the molecules of the solid have spread to every part.

Again, ice gradually disappears even when below the freezing point. Camphor and iodine when gently heated readily pass into vapour without melting. Indeed, if a piece of camphor is cut so as to have sharp corners the wasting away at ordinary temperatures will be seen by the rounding of the corners in a very few days. This change from solid to vapour is called *sublimation*.

The motions of the molecules of a solid are much less free than those of a liquid. They vibrate back and forth about their mean positions, but as a rule are kept well to their places by their neighbours. When heated, the molecules are more vigorously agitated and the body expands, and if the heating is intense enough it becomes liquid.

Since when a solid changes to a liquid its volume is not greatly changed we conclude that in the two states of matter the molecules are about equally close together. But in gases they are much farther apart. A cubic centimetre of water when turned into steam occupies about 1600 c.c.

159. Viscosity. Tilt a vessel containing water; it soon comes to its new level. With ether or alcohol the new level is reached even more quickly, but with molasses much more slowly.

Although the molecules of a liquid or of a gas move with great freedom amongst their fellows some resistance is encountered when one layer of the fluid slides over another. It is a sort of internal friction and is known as *viscosity*.

Ether and alcohol have very little viscosity; they flow very freely and are called mobile liquids. On the other hand, tar, honey and molasses are very viscous.

Stir the water in a basin vigorously and then leave it to itself. It soon comes to rest, showing that water has viscosity. The viscosity of gases is smaller than that of liquids, that of air being about $\frac{1}{80}$ that of water.

160. Distinction between Solids and Liquids. We readily agree that water is a liquid and that glass is a solid, but it is not easy to frame a definition which will discriminate between the two kinds of bodies. A liquid offers no *permanent* resistance to forces tending to change its shape. It will yield to even the smallest force if continuously applied, but the rate of yielding varies greatly with different fluids, and it is this temporary resistance which constitutes viscosity.

Drive two pairs of nails in a wall in a warm place, and on one pair lay a stick of sealing-wax or a paraffin candle, on the other a tallow candle or a strip of tallow (Fig. 172). After some days (perhaps weeks), the tallow will still be straight and unyielding while the wax will be bent.



FIG. 172.—A paraffin candle bends but a tallow one keeps straight.

Lord Kelvin describes an experiment which he made many years ago. On the surface of the water in a tall jar he placed several corks, on these he laid a large cake of shoemakers' wax about two inches thick, and on top of this again were put some lead bullets. Six months later the corks had risen and the bullets had sunk half through the cake, while at the end of the year the corks were floating in the water at the top and the bullets were at the bottom of the vessel.

These experiments show that at ordinary temperatures wax is a liquid, though a very viscous one, while tallow is a true solid.

CHAPTER XVI

MOLECULAR FORCES IN SOLIDS AND LIQUIDS

161. Cohesion and Adhesion. When we attempt to separate a solid into pieces we experience difficulty in doing so. The molecules cling together, refusing to separate unless compelled by a considerable effort. This attraction between the molecules of a body is called *cohesion*, and the molecules must be very close together before this force comes into play. The fragments of a porcelain vessel may fit together so well that the eye cannot detect any cracks, but the vessel falls to pieces at the touch of a finger.

Some substances can be made to weld together much more easily than others. Clean surfaces of metallic lead when pressed together cohere so that it requires considerable force to pull them apart; and powdered graphite (the substance used in 'lead' pencils), when submitted to very great pressure, becomes once more a solid mass.

Cohesion is the natural attraction of the molecules of a body for one another. If the particles of one body cling to those of another body there is said to be *adhesion* between them. The forces in the two cases are of the same nature, and there is really no good reason for making a distinction between them.

The force of cohesion is also present in liquids, but it is much weaker than in solids. If a clean glass rod is dipped in water and then withdrawn a film of water will be seen clinging to it; but if dipped in mercury no mercury adheres. This shows that the adhesion between glass and water is greater than the cohesion between the molecules of water, but the reverse holds in the case of mercury and glass.

162. Elasticity. When a body is altered in size or shape in any way, so that the relative positions of its parts are changed, it is said to be *strained*. A ship may be tossed about by the waves and suffer no harm, but if it runs on a sand-bar and one portion is moved with respect to the rest it becomes strained and very serious results are sure to follow.

Let us strain a body, bend it, for instance. It exerts a resistance, and on setting it free, (if the strain has not been too great), it returns to its original shape. This resisting force is due to the *elasticity* of the body. We apply an external force and thus strain the body, and this strain arouses an internal force which is precisely equal in magnitude and opposite in direction to the external force. The internal forces in a body are called *stresses*, and the *stress is proportional to the strain which accompanies it*.

Strain is of two kinds,—change of form and change of volume, and there are corresponding elasticities of form and of volume. Solids have both kinds of elasticity, while liquids and gases have only elasticity of volume,—they offer no resistance to change of form.

Steel, glass and ivory are solids which strongly resist change of form and are said to have high elasticity; on the other hand, india rubber, while easily stretched, has small elastic force.

163. How to Measure Elasticity. From a strong bracket placed high on a wall hang near together two wires *A*, *B* (Fig. 173). To the end of *A* attach a weight to keep the wire taut, and to the end of *B* attach a hook on which weights may be laid. On *B* a cardboard scale is fastened and on *A* a piece of cardboard bearing a mark (or preferably a vernier), by which any change in the length of *B* can be measured.

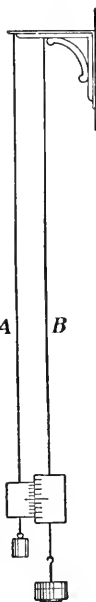

FIG. 173. — Apparatus to test Hooke's Law.

First place on B a weight sufficient to keep the wire taut, and take the reading on the scale. Then add X kilos and take the reading again. Let the increase in length be x mm. Then add another X kilos, and find the new extension. It will be found to be x mm. By continuing the process we shall find that the *extension is proportional to the stretching force*. This is known as Hooke's Law from its discoverer, Robert Hooke (1635-1703), a contemporary of Newton.

The object of having the wire A to hold the index mark is to eliminate any change in the wires through a change in temperature, or any error arising through any 'give' in the support as weights are added to B . As both wires will change in the same way the extension will be given by reading the scale.

Hooke's Law holds also in the case of a coiled spring (such as used in spring balances), and also in the bending of a bar. The amount of the bending is proportional to the force producing it.

In performing experiments on elasticity the weights used must not be too large, otherwise the body will not return to its original condition, but will take a permanent 'set.' In this case the body will have been strained beyond the limits of perfect elasticity.

164. Elasticity of Various Metals. Steel has the greatest elasticity of all the metals, and hence it is used very extensively in bridges and other structures. To stretch a rod of steel 1 m. long and one sq. cm. in section so that it is 1 m.m. longer (*i.e.*, to increase its length by $\frac{1}{10000}$) requires 20 kilos. Steel is perfectly elastic within comparatively large limits. Suppose a connecting rod 10 ft. long and 1 sq. inch in section to be exposed to a tension of 10,000 pounds; the extension would be $\frac{1}{25}$ inch. For copper a like extension would be produced with $\frac{4}{10}$ of this force.

165. Shearing Strain. In building a bridge the ends of the braces are held in place by bolts or rivets; and besides the fear of a rod being stretched beyond its elastic limit, there is danger of the bolt or rivet being cut right across its section (Fig. 174). In this case a section slides past the neighbouring section, and the strain is said to be a *shear*. When we cut a sheet of paper with scissors we *shear* it. For steel the resistance to shearing is very high.

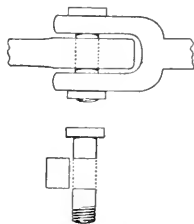

FIG. 174.—How a bolt in the end of a brace is sheared.

166. Other Properties Depending on Cohesion. A body is said to be *plastic* when it can be readily moulded into any form. The more plastic the body, the smaller is the elastic force exerted to recover its form. Clay and putty are good examples of plastic bodies.

A *malleable* body is one which can be beaten into thin sheets and still preserve its continuity. Gold is the best example. The gold leaf employed in 'gilding' is extremely thin. Between the fingers it crumples almost to nothing.

The process of making it demands much patience and skill. First, a piece of gold, by means of powerful smooth rollers, is rolled into a thin sheet, 1 ounce making a ribbon $1\frac{1}{2}$ inches wide and 10 feet long. Its thickness is then about $\frac{1}{1800}$ inch, thinner than the thinnest writing paper. The ribbon is cut into about 75 pieces, which are then placed between leaves of vellum or of a special tough paper, and are beaten with a heavy mallet until their area is multiplied about 6 times. Then each sheet is cut into 4 pieces, which are placed between sheets of gold-beaters' skin and beaten until the area is about 7 times as great. Each sheet is again cut into 4 pieces, and these, on being placed between gold-beaters' skin, are beaten until they are about $3\frac{1}{4}$ inches square. In the end the leaf is ordinarily about $\frac{1}{280000}$ inch thick, though gold has been beaten until but $\frac{1}{387000}$ inch thick. Silver and aluminium are also very malleable, but being less valuable, they are not made so thin as gold.

A *ductile* substance is one which can be drawn out into fine wires. Platinum, gold, silver, copper and iron are all very ductile. By judicious work platinum can be drawn into a wire $\frac{1}{20000}$ mm. in diameter. Glass is very ductile when heated, as also is quartz, though to soften the latter a much higher temperature is required.

A *friable* or *brittle* substance is one easily broken under a blow. Glass, diamond and ice are brittle substances.

Relative *hardness* is tested by determining which of two bodies will scratch the other. The following is the scale of hardness given by Mohs,* and generally adopted:—1. Talc, 2. Gypsum, 3. Calcite, 4. Fluorspar, 5. Apatite, 6. Feldspar, 7. Quartz, 8. Topaz, 9. Sapphire, 10. Diamond. A substance with hardness $7\frac{1}{2}$ would scratch quartz and be as easily scratched by topaz.

167. The Size of Molecules. The problem of determining the size of the molecules of matter is one of great interest, but also one of extreme difficulty. The question has been approached in various ways, and the fact that the results obtained by processes entirely different from each other agree satisfactorily is evidence that they are somewhere near the truth.

According to Avogadro's Law all gases when under the same pressure and temperature have the same number of molecules in equal volumes; hence if we know the number of molecules in a cubic centimetre of one gas we have the number for all gases, and if we know, in addition, the density of the gas we can at once calculate the mass of a single molecule.

Experiments have been made to find out the very smallest amount of matter which can be detected by our senses of sight, smell and taste; and it is astonishing what small quantities of some substances can be recognized.

On dissolving magenta dye it has been found that $\frac{1}{10,000,000}$ of a grain or 3.5×10^{-9} grams can be detected by the eye; and 3×10^{-11} grains or 1×10^{-12} grams of mercaptan, a very strong-smelling substance, can be recognized.

Glass when softened in a flame can be drawn out into fine threads; and Prof. C. V. Boys, an English physicist, has succeeded

* German mineralogist (1773-1830).

in obtaining very fine threads of quartz. First he melted some quartz in an oxy-hydrogen flame. Then he fastened another piece to an arrow, dipped it into the molten quartz, some of which adhered to it, and then shot the arrow from a cross-bow. This drew out a fibre of quartz so fine that its smallest portion could not be seen with the best microscope. Boys estimated that its diameter was not greater than $\frac{1}{1,000,000}$ inch. One cubic inch of quartz would make over 20,000,000 miles of such fibre. If we supposed this to be wound on a reel and then unwound by an express train moving at the rate of a mile a minute, over 38 years would be required. It is quite certain that a section of this fibre must contain a large number of molecules, but for simplicity let us suppose the fibre to be composed of a single row of molecules in contact. A sphere $\frac{1}{1,000,000}$ inch in diameter made from quartz would weigh 3.5×10^{-16} grains or 1.23×10^{-17} grams. The molecule of quartz must weigh less than this. But the molecule of quartz is 60 times as heavy as that of hydrogen, and so the latter must weigh less than 2×10^{-19} grams. Now 1 c.c. of hydrogen weighs 0.00009 or 9×10^{-5} grams. Hence the number of hydrogen molecules in 1 c.c. must be greater than $(9 \times 10^{-5}) \div (2 \times 10^{-19}) = 4.5 \times 10^{14}$. As we shall see presently, there are likely 100,000 times as many.

In recent years a wonderful property has been discovered to belong to certain substances, which has been named *radio-activity* (see § 582). Substances which are radio-active are able to fog a sensitive photographic plate even though it be securely packed in a box, they can discharge an electrified body and do other extraordinary things. Uranium and thorium are two of these substances, but radium and polonium appear to be the most powerful of them. These substances are exceedingly scarce and hence are extremely expensive.

The radiation which radium is continually giving out has been most carefully investigated by Rutherford,* and has been found to consist of three parts, which he named the Alpha, Beta and Gamma Rays.† Further examination has shown that the Alpha rays are made up of small particles, or corpuscles, travelling at a very great speed, each carrying a small charge of electricity, and when these corpuscles are collected in a vessel they are found to be the gas helium. Each corpuscle is a molecule of helium charged with electricity!

*Now of the University of Manchester, England. For ten years Professor of Physics at McGill University, Montreal.

† α (alpha), β (beta), γ (gamma), are the first three letters of the Greek alphabet.

Now Rutherford and Geiger have devised a method by which the passage of a single Alpha corpuscle into a suitable receiving vessel can be detected, and by actual count and calculation they have found that 1 gram of radium sends out 13.6×10^{10} particles per second. But it has also been found that 1 gram of radium produces 0.46 c. mm. of the gas helium per day which is 5.32×10^{-6} c. mm. per second. It follows then that in 5.32×10^{-6} c. mm. of helium gas there are 13.6×10^{10} molecules

Hence,

$$1 \text{ c.c. of the gas contains } \frac{13.6 \times 10^{10} \times 10^3}{5.32 \times 10^{-6}} = 2.56 \times 10^{19}$$

molecules, and from Avogadro's Law this is the number of molecules in 1 c.c. of all gases at standard pressure and temperature.

Since 1 c.c. of helium weighs 0.00000174 or 1.74×10^{-6} grams, we at once deduce that 1 molecule of helium weighs 6.8×10^{-26} grams. Also, the average distance apart of the molecules = 3.4×10^7 cm.

Rutherford has given several other methods of calculating the number of molecules, and taking the average of them all he finds

1 c.c. of gas at ordinary pressure and temperature
contains 2.77×10^{19} molecules.

Lord Kelvin has also calculated in several ways the size of molecules, and he gives the following illustration.

“Imagine a rain-drop, or a globe of glass as large as a pea, to be magnified up to the size of the earth, each constituent molecule being magnified in the same proportion. The magnified structure would be more coarse-grained than a heap of small shot, but probably less coarse-grained than a heap of cricket balls.”



SIR JOSEPH THOMSON. Born in Manchester, 1856. Cavendish Professor of Experimental Physics at Cambridge University, England.

168. Nature of the Molecule.

In the discussion given above, molecules have been treated as simple bits of matter, like grains of wheat in a bushel measure, though reasons have been given for believing that they are in motion. The view ordinarily

held has been that a compound body is made up of molecules, and that each molecule can be broken up into elementary atoms (§ 147).

But in recent years the investigations of various physicists, the most distinguished of whom is Sir Joseph Thomson, have led to the belief that the atom itself is a complex organization. According to this theory the atom of a substance has a certain amount of positive electricity as its nucleus, and about this a large number of very minute negatively-charged corpuscles or electrons revolve. Indeed the construction of the atom has been compared to that of our solar system, which has the sun as its centre and the planets revolving about it. Though the evidence in favour of some such view is undisputed, the theory is at present in a speculative stage and need not be considered further in a book like this.

CHAPTER XVII

PHENOMENA OF SURFACE TENSION AND CAPILLARITY

169. Forces at the Surface of a Liquid. On slowly forcing water out of a medicine dropper we see it gradually gather at the end (Fig. 175), becoming more and more globular, until at last it breaks off and falls a sphere. When mercury falls on the floor it breaks up into a thousand shining globules. Why do not these flatten out? If melted lead be poured through a sieve at the top of a

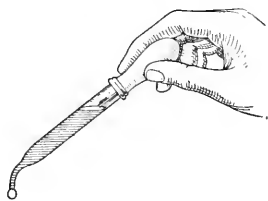

Fig. 175.—A drop of water assumes the globular form.

tower it forms into drops which harden on the way down and finally appear as solid spheres of shot.

A beautiful way to study these phenomena was devised by the Belgian physicist Plateau.* By mixing in the proper proportions water and alcohol (about 60 water to 40 alcohol), it is possible to obtain a mixture of the same density as olive oil. By means of a pipette now introduce olive oil into the mixture (Fig. 176). At once it assumes a globular form. In this case it is freed from the distorting action of gravity and rests anywhere it is put.

When the end of a stick of sealing-wax or of a rod of glass is heated in a flame it assumes a rounded form.

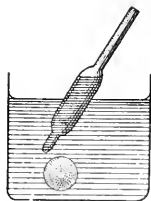

Fig. 176.—A sphere of olive oil in a mixture of water and alcohol.

These actions are due to cohesion. A little consideration would lead us to expect the molecules at the surface to act in

* Born 1801, died 1883. From 1829 his eyesight gradually deteriorated, and it failed entirely in 1843.

a manner somewhat different from those in the interior of a liquid. Let a be a molecule well within the liquid (Fig. 177). The molecule is attracted on all sides by the molecules very close to it, within its sphere of action (which is extremely small, see § 161), and as the attraction is in all directions it will remain at rest. Next consider a molecule



FIG. 177.—Behaviour of molecules within the liquid and at its surface.

b which is just on the surface. In this case there will be no attraction on b from above, but the neighbouring molecules within the liquid will pull it downwards. Thus there are forces pulling the surface molecules into the liquid, bringing them all as close together as possible, so that the area of the surface will be as small as possible. It is for this reason that the water forms in spherical drops, since, for a given volume, the sphere has the smallest surface.

The surface of a liquid behaves precisely as though a rubber membrane were stretched over it, and the phenomena exhibited are said to be due to *surface tension*.

170. Surface Tension in Soap Films. The surface tension of water is beautifully shown by soap bubbles and films. In these there is very little matter, and the force of gravity does not interfere with our experimenting. It is to be observed, too, that in the bubbles and films there is an outside and an inside surface, each under tension.

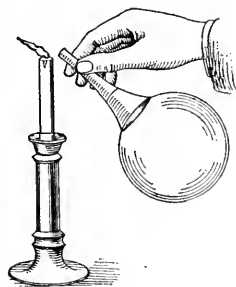

FIG. 178.—Soap-bubble blowing out a candle.

In an inflated toy balloon the rubber is under tension. This is shown by pricking with a pin or untying the mouthpiece. At once the air is forced out and the balloon becomes flat. A similar effect is obtained with a soap bubble. Let it be blown on a funnel, and the small end be held to a candle flame (Fig. 178). The

outrushing air at once blows out the flame, which shows that the bubble behaves like an elastic bag.

There is a difference, however, between the balloon and the bubble. The former will shrink only to a certain size; the latter first shrinks to a film across the mouth of the funnel and then runs up the funnel handle ever trying to reach a smaller area.

Again, take a ring of wire about two inches in diameter with a handle on it (Fig. 179). To two points on the ring tie a fine thread with a loop in it. Dip the ring in a soap solution and obtain a film across it with the loop resting on the film. Now, with the end of a wire or with the point of a pencil, puncture the film within the loop. Immediately the film which is left assumes as small a surface as it can, and the loop becomes a perfect circle, since by so doing the area of the film becomes as small as possible.

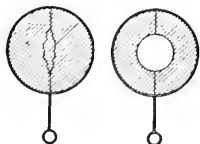

FIG. 179.—A loop of thread on a soap film.

171. **Contact of Liquid and Solid.** The surface of a liquid resting freely under gravity is horizontal, but where the liquid is in contact with a solid the surface is usually curved. Water in contact with clean glass curves upward, mercury curves downward. Sometimes when the glass is dirty the curvature is absent.

These are called *capillary* phenomena, for a reason which will soon appear. The angle of contact A (Fig. 180) between the surfaces of the liquid and solid is called the capillary angle. For *perfectly* pure water and clean glass the angle is zero, but with slight contamination, even such as is caused by exposure to air the angle may become 25° or more. For pure mercury and clean glass the angle is about 148° , but slight contamination reduces this to 140° or less. For turpentine it is 17° , and for petroleum 26° .



FIG. 180.—Water in a glass vessel curves up, mercury curves down.

172. Level of Liquids in Capillary Tubes. In § 105 it was stated that in any number of communicating vessels a liquid stands at the same level. The following experiment gives an apparent exception to this law. Let a series of capillary* tubes, whose internal diameters range from say 2 mm. to the finest obtainable, be held in a vessel containing water (Fig. 181). It will be found that in each of them the level is above that of the water in the vessel, and that the finer the tube the higher is the level. With alcohol the liquid is also elevated, (though not so much), but with mercury the

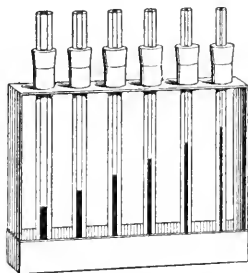

FIG. 181.—Showing the elevation of water in capillary tubes.

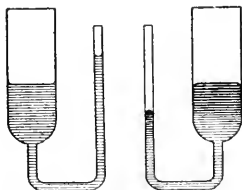

FIG. 182.—Contrasting the behaviour of water (left) and mercury (right).

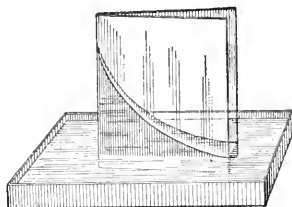

FIG. 183.—Water rises between the two plates of glass which touch along one edge.

liquid is depressed. The behaviour of mercury can conveniently be shown in a U-tube as in Fig. 182.

Another convenient method of showing capillary action is illustrated in Fig. 183. Take two square pieces of window glass, and place them face to face with an ordinary match or other small object to keep them a small distance apart along one edge while they meet together along the opposite edge. They may be held in this position by an elastic band. Then stand the plates in a dish of coloured water. The water at once creeps up between the plates, standing highest where the plates meet.

* Latin, *Capillus*, a hair.

When a glass rod is withdrawn from water some water clings to it, and the liquid is said to wet the glass. If dipped in mercury, no mercury adheres to the glass. Mercury does not wet glass.

The following are the chief laws of capillary action:—

- (1) *If a liquid wets a tube, it rises in it; if not, it falls in it.*
- (2) *The rise or depression is inversely proportional to the diameter of the tube.*

173. Explanation of Capillary Action. Capillary phenomena depend upon the relation between the cohesion of the liquid and the adhesion between the liquid and the tube.

In all cases the surface of a liquid at rest is perpendicular to the direction of the resultant force which acts on it. Usually the surface is horizontal, being perpendicular to the plumb-line, which indicates the direction of the force of gravity. In the case of contact between a solid and a liquid the forces of adhesion and cohesion must be taken into account, since the force of gravity acting on a particle of matter is negligible in comparison with the attraction of neighbouring particles upon it.

Consider the forces on a small particle of the liquid at O .

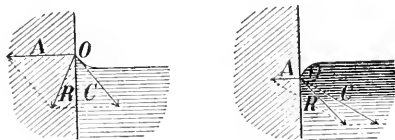

FIG. 184.—Diagrams to explain capillary action.

(Fig. 184.) The force of adhesion of the solid will be represented in direction and magnitude by the line A , that of the cohesion of the rest of the liquid by the line C . Compounding A and C by the parallelogram law (§ 55) the resultant force is R . The surface is always perpendicular to this resultant. When C greatly exceeds A the liquid is depressed; if A greatly exceeds C , it is elevated.

In the case of capillary tubes the column of liquid which is above the general level of the liquid is held up by the adhesion

of the glass tube for it. The total force exerted varies directly as the length of the line of contact of the liquid and the tube, which is the inner circumference of the tube; while the quantity of liquid in the elevated (or depressed) column is proportional to the *area* of the inner cross-section of the tube. If the diameter of the tube is doubled the lifting force is doubled and so the quantity of liquid lifted is doubled; but as the area is now *four* times as great the height of the column lifted is one-half as great.

Hence the elevation (or depression) varies inversely as the diameter of the tube.

174. Interesting Illustrations of Surface Tension and Capillarity.*

It is not easy to pour water from a tumbler into a bottle without spilling it, but by holding a glass rod as in Fig. 185, the water runs down into the bottle and none is lost. The glass rod may be inclined but the elastic skin still holds the water to the rod.



FIG. 185.—How to utilize surface tension in pouring a liquid.

Water may be led from the end of an eave-trough into a barrel by means of a pole almost as well as by a metal tube.

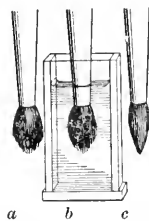

FIG. 186.—Surface tension holds the hairs of the brush together.

When a brush is dry the hairs spread out as in Fig. 186*a*, but on wetting it they cling together (Fig. 186*c*). This is due to the surface film which contracts and draws the hairs together. That it is not due simply to being wet is seen from Fig. 186*b*, which shows the brush in the water but with the hairs spread out.

A wire sieve is wet by water, but if it is covered with paraffin wax the water will not cling to it. Make a dish out

* Many beautiful experiments are described in "Soap Bubbles and the Forces which Mould Them," by C. V. Boys.

of copper gauze having about twenty wires to the inch; let its diameter be about six inches and height one inch. Bind it with wire to strengthen it. Dip it in melted paraffin wax, and while still hot knock it on the table so as to shake the wax out of the holes. A good sized pin will still pass through the holes and there will be over 10,000 of them. On the bottom of the dish lay a small piece of paper and pour water on it. Fully half a tumblerful of water can be poured into the vessel and yet it will not leak. The water has a skin over it which will suffer considerable stretching before it breaks. Give the vessel a jolt, the skin breaks and the water at once runs out. A vessel constructed as described will also float on the surface of water.

Capillary action is seen in the rising of water in a cloth, or in a lump of sugar when touching the water; in the rising of oil in a lamp-wick and in the absorption of ink by blotting paper.

175. Small Bodies Resting on the Surface of Water.

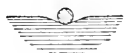

FIG. 187.—Needle on the surface of water kept up by surface tension.

By careful manipulation a needle may be laid on the surface of still water (Fig. 187). The surface is made concave by laying the needle on it, and in the endeavour to contract and smooth out the hollow, sufficient force is exerted to support the needle, though its density is $7\frac{1}{2}$ times that of water. When once the water has wet the needle the water rises against the metal and now the tendency of the surface to flatten out will draw the needle downwards.

If the needle is magnetized, it will act when floating like a compass needle, showing the north and south direction.

Some insects run over the surface of water, frequently very rapidly (Fig. 188). These are held up in the same way as the needle, namely, by the skin on the surface, to rupture which requires some force.



FIG. 188.—Insect supported by the surface tension of the water.

PART V—WAVE MOTION AND SOUND

CHAPTER XVIII

WAVE MOTION

176. **Characteristic of Wave-Motion.** It is very interesting to stand on the shore of a large body of water and watch the waves, raised by a stiff breeze, as they travel majestically along. Steadily they move onward, until at last, crested with foam, they roll in upon the beach, breaking at our feet. The great ridges of water appear to be moving bodily forward towards us, but a little observation and consideration will convince us that such is not the case.

By watching a log, a sea-fowl or any other definite object floating on the surface, we see that, as the waves pass along, it simply moves up and down, not coming appreciably nearer to us.

We see, then, that the *motion* of the water is handed on but not the water itself. In the case of a flowing stream the water itself moves and, perhaps, turns our water-wheels. Equally certain it is, however, that energy (that is, ability to do work), is transmitted by waves. A small boat, though at the distance of several miles from the course of a great steamer, will, sometime after the latter has passed, experience a violent motion, produced by the "swells" of the large vessel. The water has not moved from one to the other, but it is nevertheless the medium by which considerable energy has been transmitted.

The motion of each particle of water is similar to that of a pendulum. It is drawn aside, then swings through its mean position, at which place its motion is most rapid, and its momentum carries it forward to the farthest part of its course. Here it comes to rest and then it returns through its mean position to its starting-point.

A peculiar characteristic of wave-motion is that, while the particles of water, or other medium, never move far from their ordinary positions of equilibrium, yet energy is transmitted from one place to another by means of the motion.

When, further, we learn that the *sound* of the rolling and breaking waves is conveyed to our ears by a wave-motion in the atmosphere about us; and that the *light* by which we see these and other wonderful things, is also a wave-motion, of a kind still more difficult to comprehend, produced in a medium called the *ether*, which is believed to fill all space, penetrating even between the particles of ordinary matter, our interest is increased; and we realize how necessary it is to understand the laws of wave-motion. The subject, however, is a very extensive one, and only the simplest outline of it will be given here.

177. Cause of Waves on Water. Water in a state of equilibrium assumes the lowest possible level. If then an elevation or a depression in the surface be produced at any point, waves will be excited and will spread out from that point.

Let a stone be thrown into the water. It makes an opening in the water, at the same time elevating the surface of the water surrounding it. At once the neighbouring water rushes forward to fill up the vacant space, but on arriving there its momentum does not allow it to come to rest at once. The water, coming in from all sides, now raises a heap where the stone entered. This falls back, and the motion continues, until at last it dies away through friction.

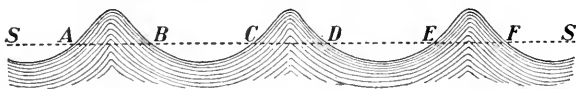

FIG. 189.—The water from the troughs has been raised into the crests, thus increasing the potential energy and causing wave-motion.

Suppose *SS* (Fig. 189) to be the natural level surface of the water when in equilibrium. It is evident, when there is such

a wave-motion as here illustrated, that by some means the water has been taken out of the 'troughs' BC , DE , etc., and raised into the 'crests' AB , CD , EF , etc., and thus the potential energy has been increased. At once the crests begin to fall, but on account of their momentum they will sink below the position of equilibrium, and thus an oscillation is produced. In this case the continued motion is due to the *force of gravity*.

However, there is another source besides gravity which produces motion of the surface of a liquid. In § 169 it was stated that a liquid behaves as though there is an elastic skin stretched over its surface, which tends to reduce the surface to as small dimensions as possible. This skin gives rise to the phenomena of surface tension.

Consider now liquid at rest in a vessel,—a cup of tea, for instance. If any object is touched to that surface its area will be increased and surface tension will endeavour to prevent this. Now it is evident that if by a current of air (or in any other way) the surface which is naturally level as SS (Fig. 190) is given the wavy form shown in the figure, the area of the surface is increased, and surface tension will strive to reduce this and to bring about equilibrium again.



FIG. 190.—Small waves, or ripples, on a liquid, due chiefly to surface tension.

Thus surface tension as well as gravity is competent to produce waves on the surface of a liquid. Indeed it has been found that in the case of short waves surface tension is much more effective than gravity, while in large waves the reverse holds.

These small waves, chiefly due to surface tension, are known as *ripples*.

178. Definition of Wave-length. A continuous series of waves, such as one can produce by moving a paddle back-and-forth in the water, or by lifting up and down a block floating on the water, is called a *wave-train*. The number of waves in such a train is indefinite; there may be few or many.

If now we look along such a train we can select portions of it which are in exactly the same stage of movement, that is, which are moving in the same way at the same time. The distance between two successive similar points is called a wave-length. It is usual to measure from one crest to the next one, but any other similar points may be chosen.

Particles which are at the same stage of the movement at the same time are said to be *in the same phase*; and so we can define a wave-length as *the shortest distance between any two particles whose motions are in the same phase*.

179. Speed of Waves on Water. We have seen that the circumstances of the motion on the surface of a liquid depend on gravity and on surface tension. If the wave-length is great the surface tension may be neglected, while if the waves are very small it is all-important and the action of gravity may be left out of account.

Now for long gravity waves the speed of transmission is higher, the greater the wave-length, the speed being proportional to the square-root of the wave-length.

On the other hand, for small waves under surface tension, the speed of transmission increases as the wave-length diminishes.

180. Wave-length for Slowest Speed. On the deep sea, waves which are 100 feet from crest to crest travel at the rate of 15 miles per hour. Those with wave-length 300 feet will therefore move at the rate of $15\sqrt{3}$ or 26 miles per hour, and so on. Atlantic storm waves are often 500 or 600 feet long, and these travel at the rate of 34 and 38 miles per hour, respectively.

If a wire—a knitting needle, for instance—is moved through water, ripples are formed before it (Fig. 191), and the faster the motion of the wire, the closer are the ripples together (Fig. 191*b*), *i.e.*, the shorter is the wave-length.

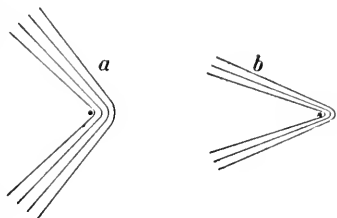

FIG. 191.—Ripples formed on moving a wire through water; (a) low-speed, (b), high-speed ripples.

It is evident that for every liquid there is some critical wave-length for which the waves travel most slowly. For water this is 0.68 inch and the speed of travel is 9 inches a second. If the waves are longer, gravity will make them travel faster; if shorter, surface tension will cause them to move faster.

181. Speed Dependent on Depth. That waves in deep water travel faster than in shallow can be shown experimentally in the following way.

Take two troughs (Fig. 192) each about 6 feet long and 1

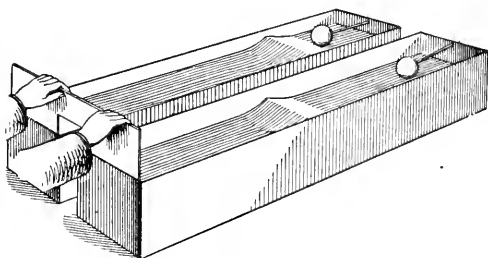

FIG. 192.—Apparatus to show that waves travel faster in deep than in shallow water.

foot wide and deep. At one end of each trough an empty tin can or a block of wood is held in such a way that it can rise and fall but not move along the trough.

Let one trough

be filled to the depth of 6 inches, the other to the depth of 3 inches. By means of a double paddle, as shown in the figure, a solitary wave is started in each trough at the same instant. The float on the deeper water will easily be seen to rise first, thus showing that the wave has travelled faster in the deeper water.

182. Motion of the Particles of Water. It may be remarked that in water waves the particles do not simply move up and down. In deep water they move in circles, but as the water becomes shallow these circles are flattened into ellipses with the long axes horizontal.

Also, the oscillatory motion of the particles rapidly diminishes with the depth. At the depth of a wave-length it is less than $\frac{1}{500}$ of that at the surface. At a few hundred feet down—a distance small compared with the depth of the ocean—the water is quite still, even though the surface may be in very violent motion under fearful storms. A submarine boat, by descending a hundred feet, could pass from the midst of a terrific tempest to a region of perfect quiet.

183. Refraction of Water Waves. It has often been observed that when waves approach a shallow beach the crests are usually approximately parallel to the shore line. In Fig. 193,

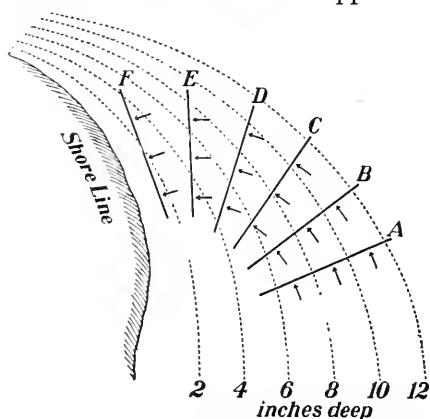

FIG. 193.—Diagram illustrating how a wave changes its direction of motion as it gets into shallower water, and is refracted.

This changing of the direction of the motion of the waves through a change in their velocity is called *refraction*.

184. Reflection of Waves. If, however, a train of water waves strike a precipitous shore or a long pier, they do not stop there, but start off again in a definite direction. This is illustrated in Fig. 194. The waves advance along *AB*, strike the pier and are reflected in the direction *BC*, the lines *AB*, *BC* making equal angles with *BD* the perpendicular to the pier.

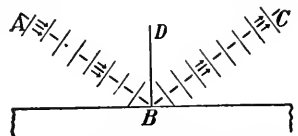

FIG. 194.—Water waves striking a long pier are reflected.

In sound and light we meet with many illustrations of reflection and refraction.

185. Study of Waves in a Cord. Let one end of a light chain or rubber tube, 8 feet or more in length, be fastened to the ceiling or the wall of a room. Then, by shaking from side to side the free end, waves will be formed and will pass freely along the tube. A rope or a length of garden hose lying on the floor may be used, but the results will not be so satisfactory.

We shall examine this motion more closely. Let us start with the tube straight as shown in (a), Fig. 195. The end A is quickly drawn aside through the space AB . The end particles

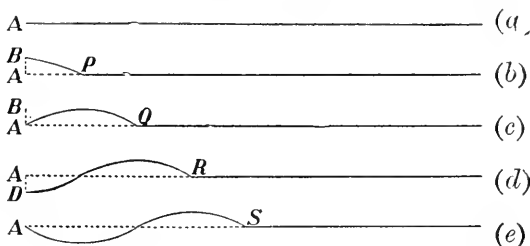

Fig. 195.—Diagram to show how a wave is formed and travels along a cord.

drag the adjacent ones after them; these drag the next ones, and so on; and when the end ones have been pulled to B the tube then has the form shown in (b).

Instead of keeping the end at B , however, let it be quickly brought back to A , that is, the motion is from A to B and B to A without waiting at B . Now the particles between B and P have been given an upward movement, and their inertia will carry them further, each pulling its next neighbour after it, until when the end is brought back to A the tube will have the form AQ , shown in (c).

Suppose, next, that the motion did not stop at A , but that it continued on to D . On arriving there the tube will have the form (d). Immediately let the end be brought back to A , thus completing the 'round trip.' The tube will now have the form shown in (e).

Notice (1) that the end has made a complete vibration, (2) that one wave has been formed, and (3) that the motion has travelled from A to S , which is a wave-length.

If the motion of the end ceased now, the wave would simply move forward along the tube. If, however, the end continued to vibrate, waves would continue to form and move along the



FIG. 196.—Three waves in a cord.

tube, as seen in Fig. 196, where three full waves are shown, moving in the direction of the arrow.

186. Relation between Wave-length, Velocity and Frequency. The time in which the end *A* executes a complete vibration is called its *period*, and the number of periods in a second is called its *frequency*, or *vibration-number*.

We have just seen that during one period the wave-motion travels one wave-length.

Let the frequency be n per second; then the period T will be $1/n$. second.

If l = wave-length,
 and v = velocity of transmission of the wave-motion;
 then $l = vT$,
 or $v = nl$.

This is a very important relation.

The *amplitude* of a vibration is the range on one side or the other of the middle point of the course. Thus AB or AD (Fig. 195) is the amplitude of the motion of the particle *A*.

187. Transverse and Longitudinal Waves. In the wave-motion just considered the direction of the motion of the particles is across, or at right angles to, the direction of propagation. Such are called *transverse* waves. In addition to the illustrations of these waves which have already been given, it may be remarked that in an earthquake disturbance the motions which do the great damage are long, transverse waves which travel along the earth's crust at the rate of from 1.6 to 4 km. per second.*

* In the destructive Messina earthquake, December 28, 1908, the speed of transmission averaged 3.3 km. (or 2 mi.) per second.

Let us now consider a long spiral spring (Fig. 197). The spiral should be 2 or 3 m. long and the diameter of the coils may be from 3 to 8 cm. One end may be securely attached to the bottom of a light box (a chalk-crayon box). Then, holding the other end firmly in the hand, insert a knife-blade between the turns of the wire and quickly rake it along the spiral towards the box.

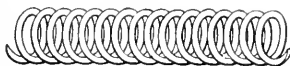

FIG. 197.—Portion of a spiral spring to illustrate the transmission of a wave. It should be 2 or 3 m. long; if of No. 22 wire the coils may be 3 or 4 cm. in diameter; if of heavier wire the coils should be larger.

In this way the turns of wire at *B*, Fig. 198, in front of the hand are crowded together, and the turns behind, for about the same distance, are pulled wider apart.

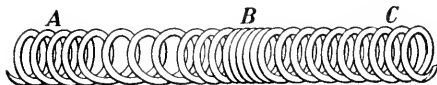

FIG. 198.—A wave consists of a condensation *B*, and a rarefaction *A*.

The crowded part of the spiral may be called a *condensation*, the stretched part a *rarefaction*.

Now watch closely and you will see the condensation, followed by the rarefaction, run with great speed along the spiral, and on reaching the end it will give a sharp thump against the box. Here it will be reflected, and will return to the hand from which it may be reflected and again return to the box.

If a light object be tied to the wire at any place, it will be seen, as the wave passes, to receive a sharp jerking motion forward and backward in the direction of the length of the spiral.

On a closer examination we find that the following is what takes place.

By applying force with the hand to the spiral we produce a crowding together of the turns of wire in the section *B*, and a separation at *A*. Instantly the elastic force of the wire causes *B* to expand, crowding together the turns of wire in front of it (in the section *C*), and thus causing the condensation to be transmitted forward. But the coils in *B* do not

stop when they have recovered their original position. Like a pendulum they swing beyond the position of rest, thus producing a rarefaction at B where immediately before there was a condensation. Thus the pulse of condensation as it moves forward will be followed by one of rarefaction.

Such a vibration is called longitudinal; the motions of the particles are parallel to the direction of transmission.

188. Length and Velocity of Waves in a Cord. Let us experiment further with the stretched rubber tube.

Make the end to vibrate faster; the waves produced are shorter. Stretch the tube more; the waves become longer, and travel faster.

Notice, also, that on reaching the farther end the wave is reflected as it was in the long spiral.

189. Nodes and Loops. Next, let us keep the end of the rubber tube in continual vibration. A train of waves will steadily pass along the tube, and being reflected at the other end, a train will steadily return along it. These two trains will meet, each one moving as though it alone existed.

As the tube is under the action of the two sets of waves, the direct and reflected trains, it is easy to see that while a direct wave may push downward any point on the tube a reflected one may lift it up, and the net result may be that the point will not move at all. The two waves in such a case are said to *interfere*.

That is just what does happen. By properly timing the vibrations of the end of the tube the direct and reflected trains interfere and certain points will be continually at rest.

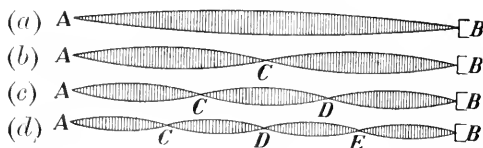

FIG. 199.—Standing waves in a cord. At A, C, D, E, B are nodes; midway between are loops.

If the end A (Fig. 199) is vibrated slowly the tube will assume the form (a).

On doubling the frequency of vibration, it will take the form (b). By increasing the frequency other forms, such as shown in (c) and (d) may be obtained. In these cases the points *A, B, C, D, E*, are continually at rest and are called *nodes*. The portion between two nodes is called a *ventral segment*, and the middle point of it we shall call a *loop*. The distance between two successive nodes is half a wave-length.

Such waves are called *stationary* or *standing waves*. As we have seen, they are caused by continual interference between the direct and the reflected waves.

190. Method of Studying Standing Waves. The most satisfactory method of producing the vibrations in a cord is to use a large tuning-fork, so arranged that the cord (which should be of silk, light and flexible) may be attached to one prong. In the absence of this the arrangement shown in

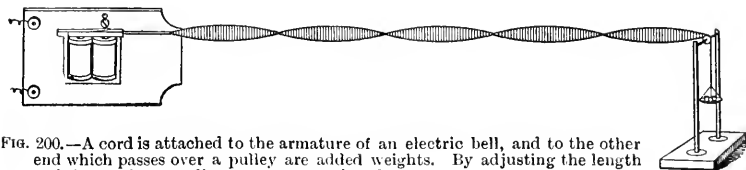

FIG. 200.—A cord is attached to the armature of an electric bell, and to the other end which passes over a pulley are added weights. By adjusting the length and the tension standing waves are produced.

Fig. 200 may be used. The gong and the hammer of a large electric bell are removed. One end of the cord is attached to the armature and the other passes over a pulley and has a pan to hold weights attached to it. In this way the length and the tension of the cord can be varied and the resulting standing waves studied.

The following law has been found to hold:—*The number of loops is inversely proportional to the square root of the tension.*

Instead of having the string pass over a pulley, it might be allowed to hang vertically with the weight tied on the end, the electric vibrator then being turned so that the armature is vertical. This arrangement, however, is not quite so satisfactory.

CHAPTER XIX

PRODUCTION, PROPAGATION, VELOCITY OF SOUND

191. Sound arises from a Body in Motion. The sensation of sound arises from various kinds of sources, but if we take the trouble to trace the sound to its origin, we always find that it comes from a material body in motion.

A violin or a guitar string when emitting a sound has a hazy outline, which becomes perfectly definite when the sound dies away. A bit of paper, doubled and hung on the string, is at once thrown off. On placing the hand upon a sounding bell we feel the movement, which, however, at once ceases, as also does the sound. On touching the surface of water with the prong of a sounding tuning-fork the water is formed into ripples, or splashes up in spray. A light ball or hollow bead suspended by a fine thread, if held against the sounding bell or tuning-fork is thrown off vigorously.

All our experience leads us to conclude that in every case *sound arises from matter in rapid vibration.*

192. Conveyance of Sound to the Ear. In order that a sound may be perceived by our ears it is evident that some sort of medium must fill the space between the source and the ear. Usually air is this medium, but other substances can convey the sound quite as well.

By holding the ear against one end of a wooden rod even a light scratch with a pin at the far end will be heard distinctly. One can detect the rumbling of a distant railway train by laying the ear upon the steel rail. The Indians on the western plains could, by putting the ear to the ground, detect the tramping of cavalry too far off to be seen. If two stones be struck together under water, the sound perceived by an

ear under water is louder than if the experiment had been performed in the air.

Thus we see that solids, liquids and gases all transmit sound. Further, we can show that some one of these is necessary.

Under the receiver of an air-pump place an electric bell, supporting it as shown in Fig. 201. At first, on closing the circuit, the sound is heard easily, but if the receiver is now exhausted by a good air-pump it becomes feebler, continually becoming weaker as the exhaustion proceeds.

If now the air, or any other gas, or any vapour, is admitted to the receiver the sound at once gets louder.

In performing this experiment it is likely that the sound will not entirely disappear, as there will always be some air in the receiver, and in addition, a slight motion will be transmitted to the pump by the suspension; but we are justified in believing that a vibrating body in a perfect vacuum will not excite the sensation of sound.

In this respect sound differs from light and heat, which come to us from the sun and the stars, passing freely through the perfect vacuum of space.

193. Velocity of Sound in Air. It is a common observation that sound requires an appreciable time to travel from one place to another. If we watch a carpenter working at a distance we distinctly see his hammer fall before we hear the sound of the blow. Also, steam may be seen coming from the whistle of a locomotive or steamboat several seconds before the sound is heard, and we continue to hear the sound for the same length of time after the steam is shut off.

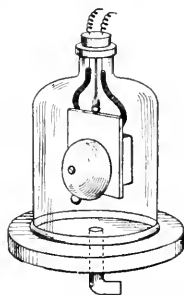

FIG. 201.—Electric bell in a jar connected to an air-pump. On exhausting the air from the jar the sound became weaker.

Some of the best experiments for determining the velocity of sound in air were made in 1822 by a commission appointed by the French Academy. The experiments were made between Monthléry and Villejuif, two places a little south of Paris and 18.6 kilometres (or 11.6 miles) apart.

Each station was in charge of three eminent scientists and provided with similar cannons and chronometers. It was found that the interval between the moment of seeing the flash and the arrival of the sound was, on the average, 54.6 seconds. This gives a velocity of 340.9 m. or 1118.15 ft. per second. Now the temperature was $15^{\circ}.9$ C., and as the velocity increases about 60 cm. per second for a rise of 1° C. this velocity would be 331.4 m. per second at 0° C. Other experimenters have obtained slightly different results.

VELOCITY OF SOUND IN AIR

Temperature.	Velocity, Per Second.
0° C. = 32° F.	332 m. = 1089 ft.
15° C. = 61° F.	341 m. = 1119 ft.
20° C. = 68° F.	344 m. = 1129 ft.
-45.6° C. = -50° F.	305.6 m. = 1002 ft.

The velocity at -50° F. was determined by Greely during his explorations in the arctic regions, 1882-3.

194. Nature of a Sound-Wave. The vibrations in sound-waves are longitudinal, the nature of which is explained in § 187.

Let a flat strip of metal be clamped in a vice or be otherwise held in a rigid support. Draw it aside, and let go. As it moves forward it condenses the air before it, and on its return the air is rarefied. With each complete vibration a wave of condensation and rarefaction is produced, and during that time

the sound will have travelled one wave-length, l . If the strip vibrates n times a second the space traversed in one second will be

$$nl = v, \text{ the velocity of sound per second.}$$

The sound, however, does not go in just one direction as shown in Fig. 202, but it spreads out in all directions, as



FIG. 202.—As the strip vibrates the air is alternately condensed and rarefied.

illustrated in Fig. 203, where spherical waves move out from the sounding bell as their centre.

195. An Air-Wave Encircling the Earth. A wonderful example of the spread of an air-wave occurred in 1883. Krakatoa is a small island between Java and Sumatra, in the East Indies, long known as the seat of an active volcano. Following a series of less violent explosions, a tremendous eruption occurred at 10 a.m. of August 27. The

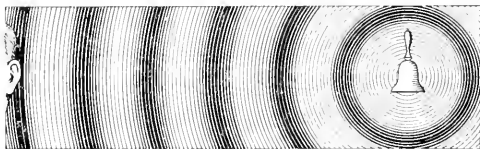

FIG. 203.—Illustrating the transmission of sound in spherical waves.

effects were stupendous. Great portions of the land, above the sea and beneath it, were displaced, thus causing an immense sea-wave which destroyed 36,000 human lives, at the same time producing a great air-wave, which at once began to traverse the earth's atmosphere. It spread out circularly, gradually enlarging until it became a great circle to the earth, and then it contracted until it came together at the antipodes of Krakatoa, a point in the northern part of South America. It did not stop there, however, but enlarging again, it retraced its course back to its source. Again it started out, went to the antipodes and returned. A third time this course was taken, and indeed it continued until the energy of the wave was spent.

The course taken by the wave was traced by means of self-registering barometers located at various observing stations throughout the world. As the wave passed over a station there was a rise

and then a fall in the barometer, and this was recorded by photographic means. In many places (Toronto included) there were four records of the wave as it moved from Krakatoa to the antipodes, and three of its return. In Fig. 204 is shown the rise in the barometer at Toronto caused by the second outward trip of the wave



Fig. 204.—A portion of the photographic record of the height of the barometer at Toronto for August 29, 1883. To obtain the record, light is projected through the barometer tube above the mercury against sensitized paper which is on a drum behind the barometer. Every two hours the light is cut off and a white line is produced on the record. Shortly after 2 a.m., August 29, there was a rise, and at about 4.40 there was another. The former was due to the passage over Toronto of the wave on the second journey from Krakatoa to the antipodes; the latter was due to the second return from the antipodes to Toronto. (From the records of the Meteorological Service, Toronto.)

and the second return. The time required to go to the antipodes and return to Krakatoa was approximately 36 hours.

The sound of the explosion was actually heard, four hours after it happened, by human ears at Rodriguez, at a distance of over 2,900 miles to the south-west. At the funeral of Queen Victoria, on February 1, 1901, the discharges of cannon were heard 140 miles away.

196. Intensity of Sound. The intensity of sound depends on three things:—

(1) *The Density of the Medium in which it is produced.* It is found that workmen in a tunnel, in which the air is under pressure, though conversing naturally, appear to each other to speak in unusually loud tones, while balloonists and mountain climbers have difficulty in making themselves heard when at great heights. The denser the medium, the louder is the sound.

(2) *The Energy of the Vibrating Body.* The amount of energy radiated per second is proportional to the square of the amplitude of the vibrating body.

(3) *The Distance of the Ear from the Sounding Body.*

Suppose the sound to be radiating from O (Fig. 205) as centre, and let it travel a distance OA in one second. The energy will be distributed amongst the air particles on the sphere whose centre is O and radius OA .

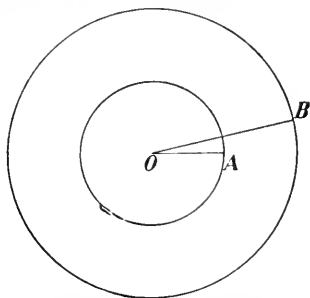

FIG. 205.—Diagram to show that the intensity of sound diminishes with the distance from the source.

In two seconds it will reach a distance OB , which is twice OA , and the energy which was on the smaller sphere will now be spread over the surface of the larger one. But this surface is *four* times that of the smaller, since the surface of a sphere is proportional to the square of its radius. Hence the intensity at B can be only one-fourth that at A , and we have the law that *the intensity of a sound varies inversely as the square of the distance from the source.*

197. Transmission by Tubes. If, however, the sound is confined to a tube, especially a straight and smooth one, it may be transmitted great distances with little loss in intensity. Being prevented from expanding, the loss of the energy of the sound-waves is caused chiefly by friction of the air against the sides of the tube.

198. Velocity of Sound in Solids by Kundt's Tube. Having determined the velocity of sound in air we can determine it in other gases and in solids by a method devised by Kundt in 1865.



FIG. 206.—The little heaps of powder in the tube are produced by the vibrations of the disc B .

BD (Fig. 206) is a brass rod about 80 or 100 cm. long and 8 or 10 mm. in diameter, securely clamped at the middle. To the end B is attached a disc of cork or other light substance which fits loosely into a glass tube about 30 or 35 mm. in diameter. A is a rod on the end of which is a disc which slides snugly in the tube, thus

allowing the distance between A and B to be varied. Dried precipitated silica, or simply powder made by filing a baked cork, is scattered along the lower side of the tube.

Now with a dry cloth or piece of chamois skin, on which is a little powdered rosin, stroke the outer half of the rod. With a little practice one can make the rod emit a high musical note. At the same time the powder in the tube is agitated, and by careful adjustment of A , the powder will at last gather into little heaps at regular intervals.

We must now carefully measure the length of the rod and also the distance between the heaps of powder, taking the average of several experiments.

By stroking the half CD of the rod we make it alternately lengthen and shorten, and the half BC elongates and shortens in precisely the same way. Thus the mid-point of the rod remains at rest, while all other portions of the rod vibrate longitudinally, the ends having the greatest amplitude.

It is evident that the middle of the rod is a node and the ends loops (§ 189), and hence if we had a very long rod and each part of it of length BD were vibrating in the same way we would have standing waves in the brass rod and BD would be one-half the wave length.

Again, as the piston at B moves forward it compresses the air in front of it and as it retreats it rarefies the air. These air-waves travel along the tube and are reflected at A and return. The two sets of waves thus meet and interfere producing stationary waves as explained in § 189. The powder gathers at the nodes, and hence the distance between the nodes is one-half the wave-length in air of the note emitted by the brass rod.

Let L = length of brass rod,

V = velocity of sound in brass,

n = frequency of note emitted,

then $2L$ = wave-length, and $V = n \times 2L$.

Again, if l = length between the heaps of powder,

and v = velocity of sound in air,

then n = frequency, and $v = n \times 2l$.

$$\text{Hence } \frac{V}{v} = \frac{n \times 2L}{n \times 2l} = \frac{L}{l},$$

$$\text{and } V = \frac{L}{l} \times v.$$

By measuring L , l , and knowing v we can at once deduce V , the velocity in brass.

Note that $2L$ = wave-length in brass, $2l$ = wave-length in air, where l = length between adjacent heaps.

On using rods of other metals we can find the velocity in each of them.

199. Velocity in Different Gases. The same apparatus can be used for different gases. To do so it is arranged as shown in



FIG. 207.—Kundt's method of finding the velocity of sound in different gases.

Fig. 207. For this purpose a glass rod is preferable. It vibrates more easily by using a damp woollen cloth. It is waxed into the cork through which it passes. The piston *D* must be reasonably tight.

As before, measure the distance between adjacent heaps when the tube is filled with air. Let it be *a*. Now fill it with carbonic acid gas and let the distance be *c*.

Then we have, velocity in air = $N \times 2 a$,
and velocity in carbon dioxide = $N \times 2 c$.

$$\text{Hence } \frac{\text{velocity in carbon dioxide}}{\text{velocity in air}} = \frac{N \times 2 c}{N \times 2 a} = \frac{c}{a},$$

and velocity in carbon dioxide = $\frac{c}{a} \times v$.

VELOCITY OF SOUND IN SOLIDS, LIQUIDS AND GASES

Substance.	Temper- ature.	Velocity.		Substance.	Temper- ature.	Velocity.	
		m. per sec.	ft. per sec.			m. per sec.	ft. per sec.
Aluminium	5104	16740	Water.....	9	1435	4708
Brass.....	3500	11480	Carbon diox-			
Copper....	20	3560	11670	ide.....	0	261.6	858
"	100	3290	10800	Illuminating			
Iron.....	20	5130	16820	gas.....	0	490.4	1609
Maple....	4110	13470	Oxygen.....	0	317.2	1041

200. Reflection of Sound. Everyone has heard an echo. A sharp sound made before a large isolated building or a steep cliff, at a distance of 100 feet or more, is returned as an echo. The sound-waves strike the flat surface and are reflected back to the ear.

When there are several reflecting surfaces at different distances from the source of sound a succession of echoes is heard. This phenomenon is often met with in mountainous regions

In Europe there are many places celebrated for the number and beauty of their echoes. An echo in Woodstock Park (Oxfordshire, England) repeats 17 syllables by day and 20 by night. Tyndall says: "The sound of the Alpine horn, echoed from the rocks of the Wetterhorn or the Jungfrau [in Switzerland] is in the first instance heard roughly. But by successive reflections the notes are rendered more soft and flute-like, the gradual diminution of intensity giving the impression that the source of sound is retreating farther and farther into the solitude of ice and snow."

The laws of reflection of sound are the same as those of light (see § 346). Let a watch be hung at the focus of a large

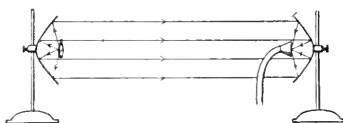

FIG. 208.—A watch is held in the focus of one concave reflector and the ticking is heard at the focus of the other. (The foci can be located by means of rays of light.)

concave mirror (Fig. 208).

The waves strike the mirror and are returned as shown in the figure, being brought to a focus again by a second mirror. On holding at this focus a funnel from which a

rubber tube leads to the ear the sound may be heard, even though the mirrors are a considerable distance apart.

In the Whispering Gallery of St. Paul's Cathedral in London, England, the faintest sound is conveyed from one side of the dome to the other, but is not heard at any intermediate point.

The Mormon Tabernacle at Salt Lake City, Utah, is an immense auditorium, elliptic in shape, 250 feet long, 150 feet wide and 80 feet high, with seating accommodation for 8000 people. A pin dropped on a wooden railing near one end, or a whisper there is heard 200 feet away at the other end with remarkable distinctness.

The bare walls of a hall are good reflectors of sound, though usually the dimensions are not great enough to give a distinct echo, but the numerous reflected sound-waves produce a *reverberation* which appears to make the words of the speaker run

into each other, and thus prevents them being distinctly heard. By means of cushions, carpets and curtains, which absorb the sound which falls upon them instead of reflecting it, this reverberation can be largely overcome. The presence of an audience has the same effect. Hence, a speaker is heard much better in a well-filled auditorium than in an empty one.

201. The Submarine Bell. A valuable application of the fact that water is a good conductor of sound is made in a method recently introduced for warning ships from dangerous places. Lighthouses and fog-horns have long been used, but the condition of the atmosphere often renders these of no avail. Submarine signals, however, can be depended upon in all kinds of weather.

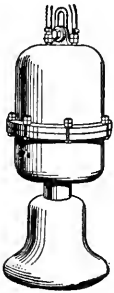

FIG. 209.—Submarine bell, worked by compressed air supplied from the shore. The mechanism for moving the hammer of the bell is contained in the upper chamber.

The submarine bell, which sends out the signals (Fig. 209), is hung from a tripod resting at the bottom of the water or is suspended from a lightship or a buoy. The striking mechanism is actuated by compressed air or electricity supplied from the shore or the lightship.

The receiving apparatus is carried by the ship. Two iron tanks are located in the bow of the vessel, one on each side (Fig. 210). These tanks are filled with salt water, and the ship's outer skin forms one side of the tank. Suspended in each tank are two microphones (§ 537), which are connected to two telephone receivers up in the pilot-house. The officer on placing these to his ears can hear sounds from a bell even when more than 15 miles away; and by listening alternately to the sounds from the two tanks he can accurately locate the direction of the bell from him. Signal stations are to be found on the shores of various countries, several being located in the lower St. Lawrence and about the maritime provinces of Canada.

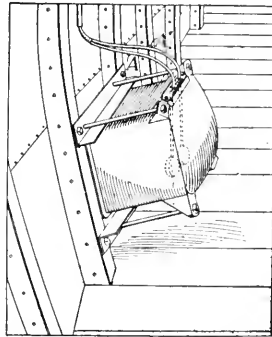

FIG. 210.—The sound from the bell is received by two tanks placed in the forepeak of the ship, one on each side. The tank is filled with salt water, and the ship's outer skin forms one of its sides. In the water are two microphones, which are connected by wires A, A to two telephone receivers up in the pilot-house.

The receiving apparatus is carried by the ship. Two iron tanks are located in the bow of the vessel, one on each side (Fig. 210). These tanks are filled with salt water, and the ship's outer skin forms one side of the tank. Suspended in each tank are two microphones (§ 537), which are connected to two telephone receivers up in the pilot-house. The officer on placing these to his ears can hear sounds from a bell even when more than 15 miles away; and by listening alternately to the sounds from the two tanks he can accurately locate the direction of the bell from him. Signal stations are to be found on the shores of various countries, several being located in the lower St. Lawrence and about the maritime provinces of Canada.

QUESTIONS AND PROBLEMS

1. Calculate the velocity of sound in air at 5° , 10° , 40° C. (See § 193.)
2. An air-wave travelled about the earth (diameter 8000 miles) in 36 hours. Find the velocity in feet per second.
3. A thunder-clap is heard 5 seconds after the lightning flash was seen. How far away was the electrical discharge? (Temperature, 15° C.)
4. The velocity of a bullet is 1200 feet per second, and it is heard to strike the target 6 seconds after the shot was fired. Find the distance of the target. (Temperature, 20° C.)
5. At Carisbrook Castle, in the Isle of Wight, is a well 210 feet deep and 12 feet wide, the interior being lined with smooth masonry. A pin dropped into it can easily be heard to strike the water. Explain. Find the interval between the moment of dropping the pin and that of hearing the sound. (Temperature, 15° C., $g = 32$.)
6. Why does the presence of an audience improve the acoustic properties of a hall?
7. Explain the action of the ear-trumpet and the megaphone or speaking-trumpet.
8. If all the soldiers in a long column keep time to the music of a band at their head will they all step together?
9. A man standing before a precipice shouts, and 3 seconds afterwards he hears the echo. How far away is the precipice? (Temperature, 15° C.)
10. In 1826 two boats were moored on Lake Geneva, Switzerland, one



Fig. 211a.—Apparatus for producing the sound, in Lake Geneva.

on each side of the lake, 44,250 feet apart. One was supplied with a bell *B* (Fig. 211a), placed under water, so arranged that at the moment it was struck a torch *m* lighted some gunpowder in the pot *P*. The sound was heard at the other boat by an observer with a watch in his hand and his ear to an ear-trumpet, the bell of which was in the water.



Fig. 211b.—Listening to the sound from the other side of the Lake.

The sound was heard 9.4 seconds after the flash was seen. Calculate the velocity of sound in water.

11. In a Kundt's tube a brass rod is 1 m. long, and five of the intervals between the dust-heaps equal 49.5 cm. Find the velocity of sound in brass.

12. When a Kundt's tube is filled with hydrogen the dust-heaps are 3.8 times as far apart as with air. Find the velocity of sound in hydrogen. (Temperature, 20° C.)

CHAPTER XX

PITCH, MUSICAL SCALES

202. Musical Sounds and Noises. The slam of a door, the fall of a hammer, the crack of a rifle, the rattling of a carriage over a rough pavement,—all such disconnected, disagreeable sounds we call *noises*; while a note, such as that yielded by a plucked guitar string or by a flute, we at once recognize as musical.

A musical note is a continuous, uniform and pleasing sound; while a noise is a shock, or an irregular succession of shocks, received by the ear.

Against the teeth on a rotating disc (Fig. 212) hold a card. When the speed is slow we hear each separate tap as a noise, but as it is increased these taps at last blend into a clear musical note.

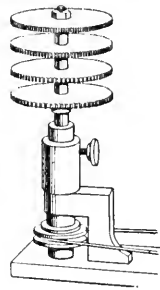

FIG. 212. — Toothed wheels on a rotating machine. On holding a card against the teeth a musical sound is heard.

The same result, with a rather more pleasing effect is obtained by sending a current of air through holes regularly spaced on a circle near the circumference of a rotating disc (Fig. 213). The little puffs through the holes blend into a

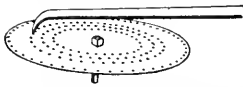

FIG. 213.—Air is blown through the holes in the rotating plate.

pleasing note.

It is possible for a number of musical notes to be so jumbled together that the periodic nature is entirely lost, and then the result is a noise. If the holes in the disc (Fig. 213) are irregularly spaced we get a noise, not a musical note.

A musical tone is due to rapid periodic motion of a sonorous body ; a noise is due to non-periodic motion.

203. Pitch. There are three features by which musical tones are distinguished from each other, namely:—

(1) *Intensity or Loudness*, (2) *Pitch*, (3) *Quality*.

The intensity of a sound depends on the amplitude of the vibrations of the air particles at the ear, and has already been discussed (§ 196).

The pitch of a sound depends on the number of vibrations per second, or what amounts to the same thing, upon the number of sound-waves which enter the ear in a second.

This can be tested very easily by means of the toothed wheel or the perforated disc just described. When the speed of rotation is slow, and hence the number of vibrations per second few, the pitch is low, and when it is increased the pitch becomes higher.

204. Determination of Pitch. The number of vibrations corresponding to any given pitch may be determined by various devices. One is the toothed wheel shown in Fig. 212. Suppose we wish to find the number of vibrations of a tuning-fork. The speed of rotation is increased until the sound given by the wheel is the same as that by the fork. Then the speed is kept constant for a certain time—say half a minute—and the number of turns of the crank in this time is counted and the rotations of the wheel deduced. Then on multiplying this number by the number of teeth on the wheel we can at once deduce the number of vibrations per second. The perforated disc may be used in the same way.

A more satisfactory instrument is that shown in Fig. 214 and known as a siren. It was invented by Cagniard de la Tour in 1819.

A perforated metal disc *B* rotates on a vertical axis, just above a cylindrical air-chamber *C*. The upper end of the chamber and also the disc are perforated at equal intervals along a circle which has as centre the axis of rotation. The upper and lower holes correspond in number, position and size, but they are drilled obliquely, those in the disc sloping in a direction opposite to those in the end of the chamber. The tube *D* is connected with a bellows or other blower.

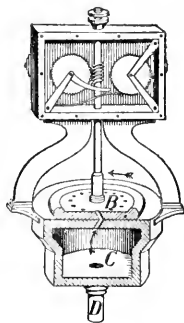

When the air is forced into the chamber and passes up through the holes, the disc is made to rotate by the air-current striking against the sides of the holes in the disc, and the more powerful the air-current the more rapid is the rotation.

Vibrations in the air are set up by the puffs of air escaping above the disc as the holes come opposite each other; and by controlling the air supply we can cause the disc to rotate at any speed, and thus obtain a sound of any desired pitch.

Having obtained this sound, a mechanical counter, in the upper part of the instrument, is thrown in gear and, keeping the speed constant for any time, this will record the number of rotations. The number of vibrations is obtained at once by multiplying the number of rotations by the number of holes in the disc and dividing by the number of seconds in the interval.

A method depending on the principle of resonance is described in § 221.

205. Limits of Audibility of Sounds. Not all vibrations, even though perfectly periodic, can be recognized as sounds, the power of detecting these varying widely in different persons. For ordinary ears the lowest frequency which causes the sensation of a musical tone is about 30 per second, the highest is between 10,000 and 20,000 per second

In music the limits are from about 40 to 4000 vibrations per second, the piano having approximately this range. The range of the human voice lies between 60 and 1300 vibrations per second, or more than $4\frac{1}{2}$ octaves; a singer ordinarily has about two octaves.

206. Musical Combinations or Chords. A musical note is pleasing in itself, but certain combinations of notes are especially agreeable to the ear. These have been recognized amongst all nations from the earliest times, having been developed purely from the aesthetic or artistic side. The older musicians knew nothing about sound waves and vibration numbers; they only knew what pleased the heart and expressed its emotions.

But on measuring the frequencies of the notes of the pleasing combinations, we find that the ratios between them are peculiarly simple, and indeed that the more pleasing any combination is the simpler are the ratios between the frequencies of the notes.

207. The Octave. Pitch depends only on the number of vibrations per second; but as we compare notes of different



FIG. 215.—Central part of a piano key-board. The notes marked C_2 , C_1 , C , C' , C' , go up by octaves.

pitch with one another—for instance the notes on a piano—we are struck with the fact that when we have gone a certain distance upwards or downwards, the notes appear to repeat themselves. Of course the pitch is different but there is a wonderful similarity between the notes.

On investigation, a remarkable relation between the vibration-frequencies of the notes is revealed. Thus one note appears to be the repetition of another when their vibration-frequencies are as 2 to 1, and one is said to be an *octave* above

the other. The combination of a note and its octave is the most pleasing of all.

Between the note and its octave custom has introduced six notes, the eight notes thus obtained usually being designated in music thus:—

$$C \ D \ E \ F \ G \ A \ B \ C'.$$

As we pass from *C* to *C'* by these interpolated notes we do so by steps which are universally recognized as the most pleasing to the ear. This series of notes is called the *natural* or *major diatonic* scale.

208. Intervals of the Major and Minor Diatonic Scales.

By actual experiment it has been found that, whatever the absolute pitch may be,—whether high up in the treble, or low down in the bass,—the ratios between the vibration-frequencies of the different notes are constant.

Suppose the note *C* has a frequency 256. The entire scale is as follows:—

<i>C</i>	<i>D</i>	<i>E</i>	<i>F</i>	<i>G</i>	<i>A</i>	<i>B</i>	<i>C'</i>
256	288	320	341 $\frac{1}{3}$	384	426 $\frac{2}{3}$	480	512,

the ratios being $1 \quad \frac{9}{8} \quad \frac{5}{4} \quad \frac{4}{3} \quad \frac{3}{2} \quad \frac{5}{3} \quad \frac{15}{8} \quad 2.$

These ratios hold, whatever the absolute frequency may be. By international agreement the frequency of middle *C* of the piano is taken as 261, that of the *A* string of a violin being 435 vibrations per second. The numbers for the scale are then,

261	293.6	326.2	348	391.5	435	489.4	522.
-----	-------	-------	-----	-------	-----	-------	------

The *interval* between two notes is measured by the improper fraction obtained on dividing their frequencies.

Thus the interval *C* to *D* is $\frac{288}{256} = \frac{9}{8}$

“ “ “ *D* to *E* is $\frac{320}{288} = \frac{10}{9}$; and so forth.

Hence the intervals between the successive notes of the scale are:—

$$\begin{array}{cccccccc}
 C & D & E & F & G & A & B & C' \\
 \underbrace{\hspace{1.5em}} & \underbrace{\hspace{1.5em}} & \underbrace{\hspace{1.5em}} & \underbrace{\hspace{1.5em}} & \underbrace{\hspace{1.5em}} & \underbrace{\hspace{1.5em}} & \underbrace{\hspace{1.5em}} & \\
 \frac{9}{8} & \frac{10}{9} & \frac{16}{15} & \frac{9}{8} & \frac{15}{13} & \frac{9}{8} & \frac{16}{15} &
 \end{array}$$

This scale is called the Major Diatonic Scale. Another scale is also used in music, known as the Minor Scale. In it the ratios and intervals are:—

$$\begin{array}{cccccccc}
 A_1 & B_1 & C & D & E & F & G & A \\
 1 & \frac{9}{8} & \frac{6}{5} & \frac{4}{3} & \frac{3}{2} & \frac{8}{5} & \frac{9}{5} & 2 \\
 \underbrace{\hspace{1.5em}} & \underbrace{\hspace{1.5em}} & \underbrace{\hspace{1.5em}} & \underbrace{\hspace{1.5em}} & \underbrace{\hspace{1.5em}} & \underbrace{\hspace{1.5em}} & \underbrace{\hspace{1.5em}} & \\
 \frac{9}{8} & \frac{16}{15} & \frac{10}{9} & \frac{8}{9} & \frac{16}{15} & \frac{8}{5} & \frac{9}{5} &
 \end{array}$$

As a matter of fact, in modern music the minor scale is not always used in precisely this form, the principal difference being in the sharpening of the 7th or leading note. The major scale has a cheerful exciting tendency; the minor, to most hearers, is melancholy and pathetic.

209. Musical Chords. Two or more notes sounded simultaneously constitute a *chord*. If the effect is agreeable it is called *concord*; if disagreeable, *discord*.

The most perfect concord is C, C' , the interval between the notes being $\frac{2}{1}$ or 2. The next is C, G , the interval being $\frac{3}{2}$. It will be observed that in expressing these intervals we use only the small numbers 1, 2, 3.

When the notes C, E, G are sounded together the effect is extremely pleasing. This combination is called the Major Triad, and when C' is added to it we get the Major Chord. The frequencies of the triad have the ratios:

$$C : E : G = 4 : 5 : 6.$$

A close examination of the Major Scale shows that it is made up of repetitions of this triad. Thus C, E, G, F, A, C' and

$$\begin{array}{cccccccc}
 C & D & E & F & G & A & B & C' & D' \\
 & & & & \underbrace{\hspace{2em}} & & \underbrace{\hspace{2em}} & & \\
 & & & & & & & &
 \end{array}$$

G, B, D' are all major triads.

210. The Scale of Equal Temperament. In musical composition C is not always used as the first or key-note of the scale, but any note may be chosen for that purpose. On calculating the frequencies of the different notes of the major

scale when *C*, *D* and *E* are key-notes (taking $C = 256$), we find them to be as follows:—

	<i>C</i>	<i>D</i>	<i>E</i>	<i>F</i>	<i>G</i>	<i>A</i>	<i>B</i>	<i>C'</i>	<i>D'</i>	<i>E'</i>	<i>F'</i>	<i>G'</i>
Key of C	256	288	320	$341\frac{1}{3}$	384	$426\frac{2}{3}$	480	512	576	640	$682\frac{2}{3}$	768
Key of D	270	288	324	364	380	432	480	540	576	648	720	760
Key of E	$266\frac{2}{3}$	300	320	360	400	$426\frac{2}{3}$	480	$533\frac{1}{3}$	600	640	720	800

Comparing the first two scales together, we see that the second requires 5 notes not in the first; the third scale requires 3 notes not found in either of the others. With each new scale additional notes are required. To use the minor scale still more would be needed. Indeed, so many would have to be introduced that it would be quite impracticable to construct an instrument with fixed notes, such as the piano or organ, to play in all these keys.

The difficulty is overcome by *tempering* the scale, *i.e.*, by slightly altering the intervals. In the *scale of equal temperament*, which is the one usually adopted, the octave contains 13 notes, the intervals between adjacent notes all being equal. Each is equal to $\sqrt[13]{2} = 1.059$, and is called a semi-tone. On multiplying the frequency of a note by this ratio, the note next above is obtained. From the *chromatic scale* of 13 notes thus obtained, the intervals of the major scale are:— Between the 1st and 2nd, 2nd and 3rd, 4th and 5th, 5th and 6th, 6th and 7th, each two semi-tones or a whole tone, *i.e.*, $(1.059)^2$; between the 3rd and 4th and the 7th and 8th, each a semi-tone.

The following table shows the difference between the true or natural and the tempered scale:—

	<i>C</i>	<i>D</i>	<i>E</i>	<i>F</i>	<i>G</i>	<i>A</i>	<i>B</i>	<i>C'</i>
True	256	288	320	$341\frac{1}{3}$	384	$426\frac{2}{3}$	480	512
Tempered	256	287.3	322.5	341.7	383.6	430.5	483.2	512

The natural scale is more agreeable than the equally-tempered. On a violin an accomplished performer can obtain

true intervals by properly placing his fingers; and a choir of picked voices, when singing unaccompanied, uses true intervals.

211. The Harmonic Scale. When a note is sounded on certain musical instruments a practised ear can usually detect, in addition to the fundamental or principal tone, tones of other frequencies. These are much less intense than the principal tone. If the frequency of a tone is represented by 1, those tones with frequencies corresponding to 2, 3, 4, 5 are said to be harmonics of the tone 1 which is called their fundamental. The entire series is known as the *Harmonic Scale*.

The tones which are present in a note are members of such a harmonic scale, but they are not necessarily harmonics of the lowest note heard. Their fundamental may be a still lower tone. They are often referred to as overtones of the fundamental.

In the piano these harmonics are prominent. In the tuning-fork when properly vibrated, the harmonics almost instantly disappear, leaving a pure tone.

QUESTIONS AND PROBLEMS

1. From what experience would you conclude that all sounds, no matter what the pitch may be, travel at the same rate?
2. If the vibration number of C is 300 find those for F and A .
3. The wave-length of a sound, at temperature 15° C., is 5 inches. Find its frequency.
4. Why does the sound of a circular saw fall in pitch as the saw enters the wood?
5. Find the wave-length of D^{IV} (i.e., four octaves above D) in air at 0° C., taking the frequency of C as 261.
6. Find the vibration numbers of all the C 's on the piano, taking middle C as 261.
7. If the frequency of A were 452 what would be that of C ?
8. Which note has 3 times the number of vibrations of C ? Which has 5 times?
9. Find the wave-lengths in air at 20° C. of the fundamental notes of the violin G_1, D, A, E' . ($A = 435$ vibrations per second.)

CHAPTER XXI

VIBRATIONS OF STRINGS, RODS, PLATES AND AIR COLUMNS

212. The Sonometer. The vibrations of strings are best studied by means of the sonometer, a convenient form of which is shown in Fig. 216. The strings are fastened to steel

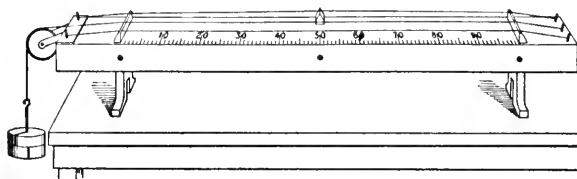

Fig. 216.—A sonometer, consisting of stretched strings over a thin wooden box. By means of a bridge we can use any part of a string.

pins near the ends of the instrument, and then pass over fixed bridges near them. The tension of a string can be altered by turning the pins with a key, or we may pass the string over a pulley and attach weights to its end. A movable bridge allows any portion of a string to be used. The vibrations are produced by a bow, by plucking or by striking with a suitable hammer.

The thin wooden box which forms the body of the instrument strengthens the sound. If the ends of a string are fastened to massive supports, stone pillars for instance, it emits only a faint sound. Its surface is small and it can put in motion only a small mass of air. When stretched over the light box, however, the string communicates its motion to the bridges on which it rests, and these set up vibrations in the wooden box. The latter has a considerable surface and impresses its motion upon a large mass of air. In this way the volume of the sound is multiplied many times.

The motions which the bridges and the box undergo are said to be *forced* vibrations, while those of the string are called *free* vibrations.

213. Laws of Transverse Vibrations of a String. First take away the movable bridge and pluck the string. It vibrates as a whole and gives out its *fundamental* note. Then place the bridge under the middle point of the string, and pluck again, thus setting one-half of the string in vibration. The note is now an octave above the former note.* We thus obtain twice the number of vibrations by taking half the length of the string.

If further we take lengths which are $\frac{8}{9}$, $\frac{4}{5}$, $\frac{3}{4}$, $\frac{2}{3}$, $\frac{3}{5}$, $\frac{8}{15}$ of the full length of the string we secure six notes which, with the fundamental and its octave, comprise the major scale. Now from § 208 we see that the relative frequencies of the notes of the scale are proportional to the reciprocals of these fractions, and hence we deduce the following important

LAW OF LENGTHS.—*The number of vibrations of a string is inversely proportional to its length.*

Next, let the tension of one of the strings be so altered that it emits the same note as does that one with the weight on the end of it. Then let us keep adding to the weight until the string gives a note which is one octave higher, that is, the note now obtained is in unison with that obtained from the other string when the movable bridge is put under its middle point.

It will be found that the new weight is four times the old one. Thus we see that in order to obtain twice the number of vibrations we had to multiply the tension 4 times. In order to obtain 3 times the number of vibrations we must multiply the tension 9 times; and so on. In this way we obtain the second important law, namely, the

LAW OF TENSIONS.—*The number of vibrations is proportional to the square root of the stretching weight.*

* By running up the successive notes of the scale the ear will recognize the octave when the string is just half the entire length.

Now let us see what is the effect of making the string thicker. Let us use a string of the same material but of twice the diameter. We find that the number of vibrations obtained is one-half as great. If the diameter is made three times as great, the number of vibrations is reduced to one-third; and so on. In this way we obtain the

LAW OF DIAMETERS.—*The number of vibrations is inversely proportional to the diameter of the string.*

Finally, on testing strings of different materials we would reach the

LAW OF DENSITIES.—*The number of vibrations per second is inversely proportional to the square root of the density.*

For example:—The density of steel wire is 7.86 and of platinum wire is 21.50 g. per c.c. Hence if we take wires of steel and platinum of the same diameter, length and under the same tension, the number of vibrations executed by the steel wire will be $\sqrt{\frac{21.50}{7.86}} = 1.65$ times that by the platinum.

214. Nodes and Loops in a Vibrating String. The production of nodes and loops in a vibrating string can be beautifully exhibited on the sonometer.

Place five little paper riders on the wire at distances $\frac{1}{8}, \frac{1}{4}, \frac{3}{8}, \frac{1}{2}, \frac{5}{8}$ of the wire's length from one end. Then while a tip of the finger or a feather is gently held against the string at a distance $\frac{1}{4}$ of the length from the other end, carefully vibrate the string with a bow. The string will break up into nodes and loops, as shown in the figure, the little riders keeping their places at the nodes but being thrown off at the loops. The note emitted will be 2 octaves above the fundamental, with a frequency 4 times that of the latter.

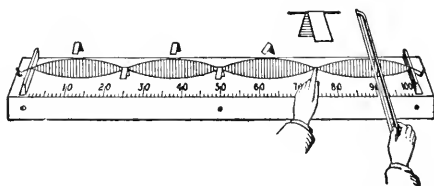

Fig. 217.—Obtaining nodes and loops in a vibrating string. The paper riders stay on at the nodes, but are thrown off at the loops.

In the same way, though somewhat more easily, the string can be made to break up into 2 or 3 segments. To obtain 2 segments, touch the string at the middle-point; for 3 segments, touch it $\frac{1}{3}$ of the string's length from the end. In both cases, of course, the paper riders must be properly placed.

215. Simultaneous Production of Tones.

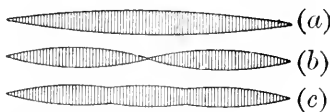

FIG. 218.—How a string vibrates when giving (a) its fundamental, (b) its first harmonic, (c) both of these together.

When a string vibrates as a whole, as shown in Fig. 218*a*, it emits its fundamental tone. To emit its first harmonic or overtone it should assume the form shown in (b).

In the same way the forms assumed when giving the higher overtones can easily be drawn.

Now it is practically impossible to vibrate the string as a whole without, at the same time, having it divide and vibrate in segments. Thus with the fundamental tone of the string will be mingled its various harmonics.

The relative strengths of these harmonics will depend on the manner in which the string is put in vibration,—whether by a bow, by plucking or by striking it at some definite point. The sound usually described as “metallic” is due to the prominence of higher harmonics.

In Fig. 218*c* is shown the actual shape of the string obtained by combining (a) and (b), that is, by adding the first harmonic to the fundamental.

216. Vibrations of Rods.

The vibration of a rod clamped at its middle and stroked longitudinally has been described in § 198, in connection with Kundt's tube.

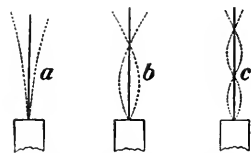

FIG. 219.—Vibrations of a rod clamped at one end.

But a rod may vibrate transversely also. Let it be clamped at one end, and the other end be drawn aside and let go. Ordinarily it will vibrate as in

Fig. 219*a*, in which case it produces its fundamental tone. But it may vibrate as illustrated in (*b*) and (*c*), emitting its overtones.

The vibrations are due to the elasticity of the rod. The investigation into these transverse vibrations is somewhat complicated and difficult, but the following simple law has been found to be true.

LAW OF TRANSVERSE VIBRATIONS OF RODS:—*The number of vibrations varies inversely as the square of the length of the rod and directly as its thickness.*

The triangle and musical boxes are examples of the transverse vibrations of rods.

217. Tuning-Fork. A tuning-fork may be considered as a rod which is bent and held at its middle point. When it vibrates the two prongs alternately approach and recede, while the stem has a slight motion up and down. Why this is so may be seen from Fig. 220. In *I*, *N*, *N* represent the nodes when the straight bar is made to vibrate. As the bar is bent more and more the nodes approach the centre, and when the fork is obtained (as in *II*) the nodes are so close together that the motion of the stem is very small. That it exists, however, can be readily shown.

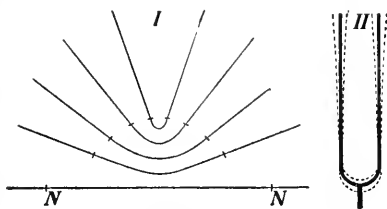

FIG. 220.—How a tuning-fork vibrates.

If a fork, after being set in vibration, is held in the hand it will continue in motion for a long time. It gives up its energy slowly and so the sound is feeble. But if the stem is pressed against the table the sound is much louder. Here the stem produces forced vibrations in the table, and a large mass of air is thus put in motion. In this case the energy of the fork is used up rapidly and the sound soon dies away.

Tuning-forks are of great importance in the study of sound. When set in motion by gentle bowing, the overtones, if present at all, die away very rapidly.

With a rise in temperature the elasticity of the steel is diminished and the pitch is slightly lowered.

218. Vibrations of Plates. The plates used in the study of sound are generally made of brass or glass, and are ordinarily square or circular in shape. The plate is held by a suitable clamp at its centre, and is made to vibrate by a violin bow drawn across the edge.

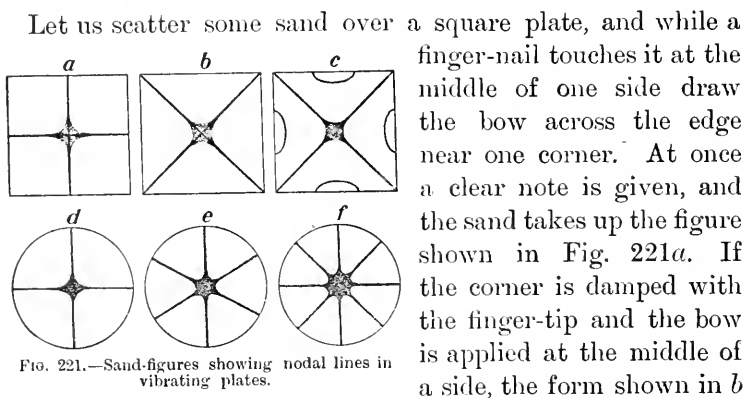

is assumed, and the note is higher than the former. By damping with two finger-tips the form *c* is obtained and a much higher note is produced.

The sand is tossed away from certain parts of the surface and collects along the *nodal* lines, that is, those portions which are at rest.

Some of the forms assumed by the sand when a circular plate is vibrated are shown in *d*, *e*, *f*. The sand-figures always reveal the character of the vibration, and the more complicated the figure, the higher-pitched the note.

219. Vibrations of Air Columns; Resonance. Let us hold a tube about 2 inches in diameter and 18 inches long with its lower end in a vessel containing water (Fig. 222); and over the open end hold a vibrating tuning-fork. Suppose the fork to make 256 vibrations per second.

By moving the tube up and down we find that when it is at a certain depth, the sound we hear is greatly intensified. This is due to the air column above the water in the tube. It must have a definite length for each fork. On measuring it for this one we find it is approximately 13 inches. With higher-pitched forks it is smaller than this, being always inversely proportional to the frequency of the fork.

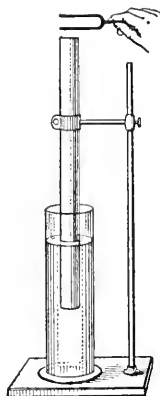

FIG. 222.—Air column in resonance with a tuning-fork.

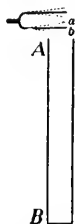

FIG. 223.—Diagram to explain resonance in a closed tube.

The air column is put in vibration by the fork, its period of *free* vibration being the same as that of the fork. The air column is said to be in *resonance* with the fork.

220. Explanation of the Resonance of the Air Column. The tuning-fork prong vibrates between the limits *a* and *b* (Fig. 223). As it moves forward from *a* to *b* it produces a condensation which runs down the tube and is reflected from the bottom. When the fork retreats from *b* to *a* a rarefaction is produced which also travels down the tube and is reflected.

Now for resonance the tube must have such a length that in the time that the prong moves from *a* to *b* the condensation travels down the tube, is reflected, and arrives back at *b* ready to start up, along with the fork, and produce the rarefaction. Thus the vibrations of the fork and of the air column are perfectly synchronous; and as the fork continues to vibrate

the motion of the air in the tube accumulates and spreads abroad in the room, producing the marked increase of sound.

221. Determination of the Velocity of Sound by Resonance. From the explanation given of the resonance of the air column in a tube, it is seen that the sound-waves travel from *A* to *B* and back again while the fork is making half of a vibration. During a complete vibration of the fork the waves will travel *four* times the length of the air column; but we know that while the fork is making one vibration the sound-waves travel a wave-length. Thus the length of the air column is one-fourth of a wave-length of the sound emitted by the fork.*

If we know the frequency of the fork we can, by measuring the length of the resonance column, at once deduce the velocity of sound. Also, if we know the length of the resonance column and the velocity of sound we can deduce the pitch.

For example, using the values just obtained,

$$\begin{aligned}\text{Frequency } n &= 256 \text{ per second,} \\ \text{Wave-length } l &= 4 \times 13 = 52 \text{ inches;} \\ \text{Then } v &= nl = 256 \times 52 \\ &= 1109 \text{ feet per second.}\end{aligned}$$

222. Forms of Resonators. A resonator is a hollow vessel

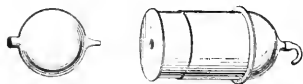

FIG. 224.—Two forms of resonators. The one on the right can be adjusted for different tones.

tuned to respond to a certain definite pitch. Two forms are shown in Fig. 224. In each case there is a large opening, to be placed near the source of the sound, while the smaller opening is either placed in the ear, or a rubber tube leads from it to the ear. The volume is carefully adjusted so as to be in resonance with a tuning-fork (or other body) vibrating a definite number of times per second.

These resonators are used to analyse a compound note. We can at once test whether there is present a tone corresponding

* More accurately the quarter wave-length of the sound is equal to the distance from the surface of the water to the top of the tube + 0.8 of the radius of the tube.

to that of the resonator, by simply holding the instrument near the sounding body; if the air in the resonator responds, that tone is present, if it does not respond, the tone is absent.

The spherical form was used largely by the great German scientist Helmholtz; the other, which can be adjusted to several tones, was introduced by Koenig. They are usually made of glass or brass, but quite serviceable ones can be made in cylindrical shape out of heavy paper. (See also § 234.)

Tuning-forks which are used in acoustics are generally mounted on a light box of definite size (see Fig. 238). This is so constructed that the air within it is in *resonance* with the fork. If a fork is held with its stem resting on the table, the table is *forced* to vibrate in *consonance* with the fork.

223. Resonance of an Open Tube. Let us take two tubes, about two inches in diameter, one of them slipping closely over the other. Each may be 15 or 18 inches long.



FIG. 225.—The length of an open tube when in resonance with a tuning-fork is one-half the wave-length of the sound.

Now vibrate the fork whose frequency is 256 per second and hold it over the end of the tube, varying the length at the same time.

At a definite length the air within the tube vigorously responds, and there is a marked increase in the sound. On measuring the length of the tube we find it is 26 inches, just twice the length of the tube when one end is closed.

But we found that the closed tube was one-fourth the wave-length of the sound to which it responded; hence an open tube is one-half the wave-length of the sound given by it.

The relation between the notes emitted by an open and a closed pipe of the same length can easily be illustrated by blowing across the end of a tube (say $\frac{1}{2}$ inch in diameter and 2 inches long), and observing the note produced when the tube is open and when a finger is held over one end of it. The former note is an octave higher than the latter.

224. Mode of Vibration in an Open Tube. When a rod is clamped at the middle and one half is stroked, as in § 198, we find that both halves lengthen and shorten. In this case there is a node at the middle, which is always at rest, and a loop at each end.



FIG. 226.—Explaining how an open pipe vibrates.

The air in an open tube vibrates quite similarly; indeed it behaves like two closed tubes placed end to end. (Fig. 226.)

The layer of air across the middle of the open tube remains at rest while those on each side of it crowd up to it and then separate from it again. The layers at either end swing back and forth, without appreciably approaching those next to them.



FIG. 227.—Section of a wooden organ pipe.

There is the greatest change of density at the middle of the tube, or the bottom of the closed tube, —*i.e.*,—at the node,—while the air particles execute the greatest swing back-and-forth (without change in the density of the air), at the open ends. There is a loop at each end.

225. Organ Pipes. The most familiar application of the vibrations of air columns is in organ pipes. They are made either of wood or metal. If of wood, pine, cedar or mahogany is used; if of metal, tin (with some lead in it) or zinc.



FIG. 228.—A metallic organ pipe.

In Fig. 227 is shown a section of a rectangular wooden pipe; in Fig. 228 is a metallic cylindrical pipe. Sometimes the pipes are conical in shape.

Air is blown through the tube T into the chamber C , and escaping from this by a narrow slit it strikes against a thin lip D . In doing so a periodic motion of the air at the lip is produced, and this sets in motion the air in the pipe, which then gives out its proper note.

Organ pipes are of two kinds,—open and closed. In some open pipes reeds are used (§ 238.) From the discussion in § 223 it will be clear that the note yielded by an open pipe is an octave higher than that given by a closed pipe of the same length.

226. Overtones (or Harmonics) in an Organ Pipe. The vibrations of the open and closed pipes which have been

described in § 219 are the simplest which the air-column can make, and they give rise to the lowest or fundamental notes of the pipes. In order to obtain the fundamental the pipe must be blown gently. If the strength of the air-current is gradually increased, other tones, namely, the overtones of the pipe, will also be heard.

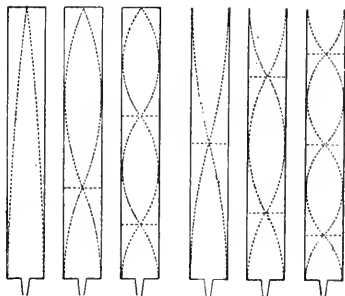

Figs. 229, 230, 231, 232, 233, 234. Showing the nodes and loops in open and closed organ pipes with different strengths of air-currents.

In Figs. 229, 230, 231 are represented the divisions of the air column in a stopped pipe corresponding to different strengths of the air-current. In Fig. 229 we have the fundamental vibration; here the column is undivided. The only node present is at the closed end, and there is a loop at the lip-end. In Fig. 230 is shown the condition of the air column corresponding to the first overtone of the pipe. There is a node at the closed end, and another at a distance $\frac{1}{3}$ of the

length of the pipe from the lip-end. Thus the distance from a node to a loop is $\frac{1}{3}$ that in Fig. 229, and the wave-length of the note is $\frac{1}{3}$ that of the fundamental. This is called the *third* harmonic, the fundamental being considered the first.

In Fig. 231 there are three nodes and three loops, in the places indicated. From a node to a loop the distance is $\frac{1}{5}$ of the length of the pipe, and hence the wave-length of the sound is $\frac{1}{5}$ that of the fundamental. This is the *fifth* harmonic. The next harmonics produced would be the seventh, the ninth, etc. Thus we see that in a closed pipe the *even* harmonics are absent, the *odd* ones only being present.

Next consider the open pipe. For the fundamental the air column divides as shown in Fig. 232, with a node at the middle and a loop at each end. With stronger blowing there is a loop at the middle as well as at each end and nodes half-way between (Fig. 233). In this case the wave-length is $\frac{1}{2}$ that of the fundamental, and the harmonic is the *second*.

In Fig. 234 is shown the next mode of division of the air column. It will be seen that the wave-length is $\frac{1}{3}$ that of the fundamental and the harmonic is the *third*. By using still stronger currents of air we get the *fourth*, *fifth*, *sixth*, etc., harmonics. Thus in an open pipe all the harmonics (or overtones) can be produced; in the closed pipe only the odd harmonics of the series are possible.

QUESTIONS AND PROBLEMS

1. Why is it advisable to strike a piano-string near the end rather than at the middle?
2. As water is poured into a deep bottle the sound rises in pitch. Explain why.
3. A stopped pipe is 4 feet long and an open one 12 feet long. Compare the pitch and the quality of the two pipes.
4. What would be the effect on an organ pipe if it were filled with carbonic acid gas? What with hydrogen?

5. Find the length of a stopped pipe whose fundamental has a frequency of 522. (Temperature, 20° C.)
6. A glass tube, 80 cm. long, held at its centre and vibrated with a wet cloth gives out a note whose frequency is 2540. Calculate the velocity of sound in glass.
7. If the tension of a string emitting the note *A* is 25 pounds, find that required to produce *C*.
8. What effect will a rise in temperature have on the notes of a pipe organ?
9. One wire is twice as long as another (of the same material and diameter), and its tension is twice as great. Compare the vibration numbers.
10. Find the length of an air column in resonance with *E*. (Temperature, 20° C.; $C = 261$.)

CHAPTER XXII

QUALITY—VIBRATING FLAMES—BEATS

227. Quality of Sound. It is a familiar and remarkable fact that though sounds having the same pitch and intensity may be produced on the piano, the organ, the cornet, or with the human voice, the source of the sound in each case can be easily recognized. That peculiarity of sound which allows us to make this distinction is called *quality*.

The cause of this was not explained until, in quite recent times, Helmholtz showed that it depends on the co-existence with the fundamental of secondary vibrations which alter the *forms* of the sound waves. These secondary vibrations are the overtones or harmonics, and their number and prominence determine the peculiar characteristics of a note.

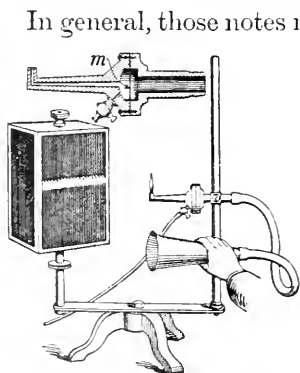

FIG. 235.—The manometric flame and mirror. A section of the gas chamber is shown separately above. On speaking into the funnel the flame dances rapidly up and down, and this motion is observed in the square mirror which is rotated by hand.

In general, those notes in which the fundamental is relatively strong and the overtones few and feeble are said to be of a 'mellow' character; but when the overtones are numerous the note is harsher and has a so-called metallic sound. If a musical string is struck with a hard body the high harmonics come out prominently.

When a violin string is bowed the first seven overtones are present, and give to the sound its piercing character. In the case of the piano the 1st, 2nd and 3rd overtones are fairly strong while the 4th, 5th and 6th are more feeble.

228. Vibrating Flames. The cause of *quality* was investigated by Helmholtz by means of spherical resonators (Fig. 224). But a very beautiful and simple way of investigating the

complex nature of sound-waves is by means of the manometric, or *pressure-measuring*, flame devised by Koenig.

A convenient form of the apparatus is shown in Fig. 235. A small chamber is divided into two compartments by a thin membrane* *m*. Gas enters one compartment as shown in the figure, and is lighted on leaving by a fine tip. The other compartment is connected by means of a rubber tube with a funnel-shaped mouthpiece.

The sound-waves enter the funnel and their condensations and rarefactions produce variations in the density of the air beside the membrane. This makes the membrane vibrate back and forth, and the gas-flame dances up and down. But these motions are so rapid that the eye cannot follow them, and in order to separate them they are viewed by reflection in a rotating mirror.

The appearance of various images of the flame is given in Fig. 236. When the mirror is at rest the image is seen as at *A*. If now the mirror is rotated while the flame is still, the image is a band of light, *B*. On singing into the conical mouthpiece the sound of *oo* as in *tool*, or on holding before it a vibrating mounted tuning-fork the gas-jet's motion appears in the mirror like *C*. If the note is sung an octave higher there will be twice as many little tongues in the same space, *D*. When these two tones are sung together images as in *E* are

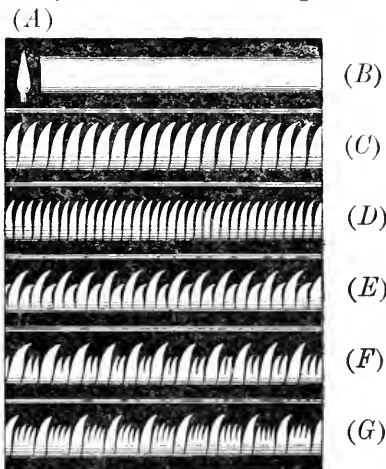

FIG. 236.—Flame pictures seen in the rotating mirror. *A*, when mirror is at rest; *B*, when flame is at rest and mirror rotating; *C*, when a tuning-fork is held before the mouthpiece; *D*, same as *C* but an octave higher; *E*, when *C* and *D* are combined; *F*, obtained with vowel *e* at pitch *C*; *G*, with vowel *o* at the same pitch.

*This may be very thin mica or rubber or gold-beater's skin.

given. On singing the vowel *e* at the pitch *C'* we obtain images as at *F*; and *G* is obtained on singing *ō* at the same pitch.

From the figures it will be seen that the last three notes are complex sounds. These dancing images have been successfully photographed on a moving film by Nichols and Merritt.

A simple form of the above apparatus can be constructed by

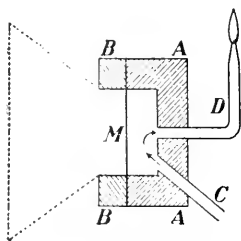

FIG. 237.—A simple form of manometric flame capsule. *AA* is a cork hollowed out, *M* is the thin membrane.

anyone (Fig. 237). Hollow out a piece of wood or a cork (2 inches in diameter), *A*, and across the opening stretch the membrane, *M*, keeping it in place by screwing or pinning a ring *B* against it. Gas enters by the tube *C* and leaves by the tube *D*. No mouthpiece is necessary but a funnel, shaped as shown in the dotted line, will increase the effect. In

place of the rotating mirror a piece of mirror 6 by 8 inches square, held in the hand almost vertical and given a gentle oscillatory motion will give good results.

229. Sympathetic Vibrations. Let us place two tuning-forks, which have the same vibration numbers, with the open ends of their resonance boxes facing each other and a short distance apart (Fig. 238). Now vibrate one of them vigorously by means of a bow or by striking with a soft mallet (a rubber stopper on a handle), and after it has been sounding for a few seconds bring it to rest by placing the hand upon it. The sound will still be heard, but on examination it will be found to proceed from the other fork.

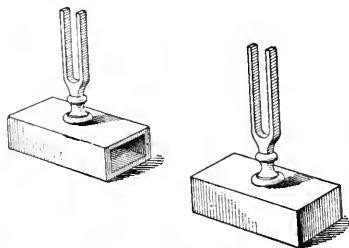

FIG. 238.—Two tuning-forks arranged to show sympathetic vibrations. When one is vibrated the other responds.

This illustrates the phenomenon of sympathetic vibrations. The first fork sets up vibrations in the resonance box on which it is mounted, and this produces vibrations in the inclosed air column. The waves proceed from it, and on reaching the resonance box of the second fork its air column is put in vibration. The vibrations are communicated to the box and then to the fork, which, having considerable mass, continues its motion for some time.

A single wave from the first fork would have little effect, but when a long series comes in regular succession each helps on what the one next before it has started. Thus the effect accumulates until the second fork is given considerable motion, its sound being heard over a large room.

For this experiment to succeed the vibration numbers of the two forks must be accurately equal.

230. Illustrations of Sympathetic Vibrations. The pendulum of a clock has a natural period of vibration, depending on its length, and if started it continues swinging for a while, but at last comes to rest. Now the works of the clock are so constructed that a little push is given to the pendulum at each swing and these, being properly timed, are sufficient to keep up the motion.

Again, it is impossible by a single pull on the rope to ring a large bell, but by timing the pulls to the natural period of the bell's motion, its amplitude continually increases until it rings properly.

When a body of soldiers is crossing a suspension bridge they are usually made to break step for fear that the steady tramp of the men might start a vibration agreeing with the free period of the bridge, and which, by continual additions, might reach dangerous proportions.

231. Beats. We shall experiment further with the two unison forks (Fig. 238). Stick a piece of wax* on each prong

*The soft modelling wax sold as "plasticine" is very convenient.

of one fork; we cannot get sympathetic vibrations now, but on vibrating the two forks at the same time a peculiar wavy or throbbing sound is heard, caused by alternate rising and sinking in loudness. Each recurrence of maximum loudness is called a *beat*.

We at once recognize that this effect is due to the interaction of the waves from the two forks, resulting in an alternate increase and decrease in the loudness of the sound.

Each fork produces condensations and rarefactions in the air, and since in a condensation the air particles have a *forward* motion while in the rarefaction the motion is *backward*, it is evident that if a condensation from one fork reaches the ear at the same time as a rarefaction from the other they will oppose their effects and the ear-drum will have little motion—the sound will be faint. If, however, a condensation from each or a rarefaction from each, arrives at the same time, the action on the ear-drum will be increased and the sound will be louder.

Consider the curves in Fig. 239. Between *A* and *B* are 8 complete waves, and between *C* and *D*, taking up the same distance, are 9 waves.

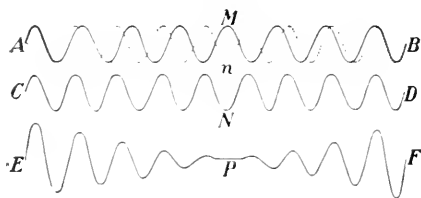

Fig. 239.—Illustrating the production of beats. The combination of *AB* with *CD* gives *EF*. The dotted curve in *AB* is the same as the curve *CD*. At *M* the motion is up, at *N* it is down, and these added give us motion as at *P*.

At the beginning at *A* and *C*, the waves are in the same phase; this is the case also at the end, at *B* and *D*. But half-way between, at *M* and *N*, the phases are opposite.

By adding the motions represented in *AB* to those represented in *CD* we obtain the motion illustrated by *EF*.

These curves can represent the motions in sound-waves if we agree that a crest in the figure shall correspond to a

condensation in the sound-wave, and hence a trough shall correspond to a rarefaction.

For simplicity let us suppose that one fork in a second gives out the 8 waves in AB while the other gives the 9 waves in CD . The combined effect, as shown in EF , will move to the ear. At first the effect will be intense, then it will be a minimum (corresponding to P), then intense again; and so on during the next second. Thus there would be *one* beat per second.

If the forks give 8 and 9 vibrations, respectively, in one-half second, *i.e.*, 16 and 18 per second, there will be one beat each half-second or *two* per second. To produce beats the forks should not differ greatly in pitch.

We arrive then at the simple law that *the number of beats per second due to two simple tones is equal to the difference of their respective vibration numbers.*

232. Tuning by Means of Beats. Suppose we wish to tune two strings to unison. Even the most unmusical person can do it. Simply vary the tension, or the length, of one of them until as they approach unison the beats are fewer per second. If one beat per second is heard, there is a difference of only one vibration per second in their frequencies. Let us alter a little more until the beats are entirely gone. The strings are then in unison.

In the same way other sounding bodies, for instance two organ pipes, or a pipe and tuning-fork, may be brought to unison.

233. Interference of Sound-Waves. The production of beats is but one of the many phenomena due to the interference of sound-waves. Let us consider two others.

In Fig. 240 are shown the extremities of the two prongs of a tuning-fork. They vibrate in such a way that they move alternately towards and away from each other. Thus while they produce a condensation in the space a between them, they produce a rarefaction at b and c on the opposite

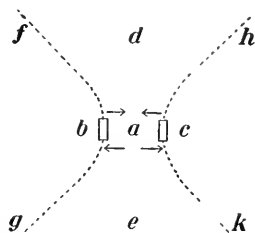

FIG. 240.—Interference with a tuning-fork.

sides. In this way each prong starts out two sets of waves, which are in opposite phases. These waves travel out in all directions, and it is evident that we can find points such that when the two sets of waves arrive there they will be in opposite phases and so, at each point, will counteract each other's effects. Such points are located on two curved surfaces, of which *fg*, *hk* are horizontal sections.

This can be demonstrated by holding a vibrating fork near the ear and then rotating it slowly. When the ear is in the positions *b*, *c*, *d*, *e* the sound is heard clearly; while if it is on either of the curved surfaces *fg*, *hk* no sound is heard.

234. Interference with Resonators. Another interesting experiment can be performed with two wide-mouthed (pickle) bottles. Vibrate a tuning-fork (256 vibrations) over the mouth of one of the bottles, and slip a microscope slide over the mouth until the air in the bottle responds vigorously. Fasten with wax the glass in the position when the bottle resounds most loudly. The bottle is then a resonator tuned to the fork.

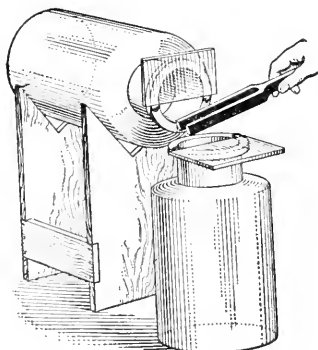

FIG. 241.—Interference with two resonators.

Tune the other bottle in the same way and then arrange them, with their mouths close together, as shown in Fig. 241. Make the fork vibrate, and then, holding it horizontally, bring it down so that the space between the prongs is opposite the mouth of the upright bottle. As it is brought into place you will observe that the sound first increases, and then suddenly fades away or disappears entirely.

The reason for this is easily understood. The air in one bottle is put in vibration by the air from between the prongs,

while that in the other is put in vibration by the air on the other side of the prongs; and these, as we have seen, are in opposite phases. Hence they interfere and produce silence.

If a card is slipped over the mouth of one of the bottles, that bottle's vibrations are shut off and the other sings out loudly.

235. Doppler's Principle. Suppose a body at A to be emitting a note of n vibrations per second. Waves will be excited in the surrounding air, and an observer at B will receive n waves each second. He will recognize a sound of a certain pitch.

Next suppose that the observer approaches the sounding body; he will now receive more than n waves in a second. In addition to the n waves which he would receive if he were stationary he will meet each second a certain number of waves, since he is nearer the sounding body at the end of a second than he was at its beginning. He will receive those waves which at the commencement of the second occupied the space he has moved. As he will now receive more than n waves per second the pitch of the sound will appear to be higher than when there was no motion.

If the observer moves away, the number of waves received will be smaller and the pitch will be lowered.

If the observer remains at rest while the sounding body approaches or recedes similar results will be obtained; and if we can determine the change in pitch we can calculate the speed of the motion. This phenomenon is known as the Doppler effect and the explanation given is known as Doppler's principle.

The Doppler effect can be observed when a whistling locomotive is approaching or receding at a rapid rate. An automobile sounding its horn is a still better illustration as its motion makes less noise. When the machine is approaching the sound is distinctly higher in pitch than when it is travelling away. Doppler's effect is referred to again in § 406.

QUESTIONS AND PROBLEMS

1. What are the fourth and fifth overtones to C ?
2. A tuning-fork on a resonance box is moved towards a wall, and a 'wavy' sound is heard. Explain the production of this.
3. Hold down two adjacent bass keys of a piano. Count the beats per second and deduce the difference of the vibration-frequencies.

4. If a circular plate is made to vibrate in four sectors as in *d*, Fig. 221, and if a cone-shaped funnel is connected with the ear by a rubber tube, and the other ear is stopped with soft wax, no sound is heard when the centre of the mouth of the cone is placed over the centre of the plate; but if it is moved outward along the middle of a vibrating sector, a sound is heard. Explain these results. (For a plate 6 inches in diameter the mouth of the funnel should be $2\frac{1}{2}$ inches in diameter. Try the experiment.)

CHAPTER XXIII

MUSICAL INSTRUMENTS—THE PHONOGRAPH

236. Stringed Instruments. In the piano there is a separate string, or a set of strings, for each note. The strings are of steel wire, and for the bass notes they are overwound with other wire, being in this way made more massive without losing their flexibility. When a key is depressed a combination of levers causes a soft hammer to strike the string at a point about $\frac{1}{7}$ of the length of the string from the end. If the instrument gets out of tune it is repaired by re-adjusting the tensions of the strings.

The harp is somewhat similar in principle to the piano, but it is played by plucking the strings with the fingers. By pressing pedals the lengths of the strings may be altered so as to sharpen or flatten any note.

The guitar has six strings, the three lower-pitched ones being of silk over-wound with fine wire. The strings are tuned to



FIG. 242.—The guitar. With the left hand the strings are shortened by pressing them against the 'frets,' while the note is obtained by plucking with the right hand.

E_1, A_1, D, G, B, E' , where D is the note next above middle C and has 293.6 vibrations per second. There are little strips across the finger-board called 'frets,' and by pressing the strings down by the fingers against these they are shortened and give out the other notes (Fig. 242).

There are only four strings on the violin, and they are tuned to

$G_1, D, A, E,$

where D is next above middle C ($A = 435$ vibrations per second). The other notes are obtained by shortening the strings by means of the fingers, but as there are no 'frets' to guide the performer, he must judge the correct positions of the fingers himself.

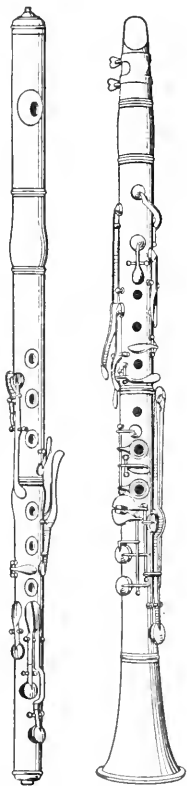

FIG. 243.
The flute.

FIG. 244.
The clarinet.

237. Pipe Organ and Flute. The action of organ pipes has been explained in §§ 225, 226. In large organs they vary in length from 2 or 3 inches to about 20 feet, and some of them are conical in shape.

In Fig. 243 is shown a flute. This is an instrument of great antiquity, though the modern form is quite unlike the old ones. By driving a current of air across the thin edge of the opening, which is near one end, the air column within is set in vibration much as in an organ pipe. In the tube there are holes which may be opened or closed by the player, opening a hole being equivalent to cutting off the tube at that place. The overtones are also used, being obtained by blowing harder.

The fife and the piccolo resemble the flute, both being open at the further end. Whistles, on the other hand, are usually closed.

238. Reed Instruments. In the ordinary organ, the mouth-organ, the accordion and some other instruments the vibrating

body is a reed, such as is shown in Fig. 245. The tongue *A* vibrates in and out of an opening which it accurately fits, the motion being kept up by the current of air which is directed through the opening.



FIG. 245.—An organ reed. The tongue *A* moves in and out of the opening. This is called a *free* reed.

In some organ pipes reeds are placed, but the note produced is due chiefly to the air column in the pipe, the reed simply serving to set it in vibration.

In Fig. 244 is shown a clarinet. This instrument has holes in the tube which are covered by keys or by the fingers of the

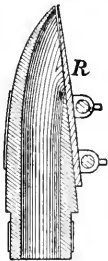

FIG. 246.—Mouth-piece of the clarinet. The reed *R* covers the opening.

player. The air in the tube is put in vibration by means of a reed made of cane shown in Fig. 246. The reed is very flexible, and the note heard is that of the air column, not of the reed.

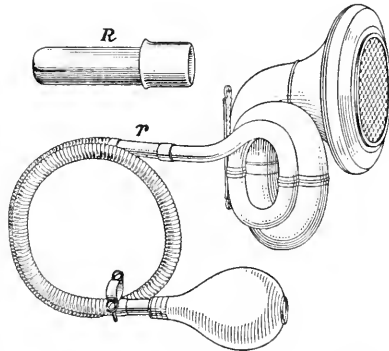

FIG. 247.—Automobile 'honk.' The reed *R* is shown separately above. It is inserted at *r*, where the flexible and brass tubes unite.

In this case the reed simply covers and uncovers the opening in the mouthpiece, being too large to pass into the opening. It is called a *striking* reed, that in the organ (Fig. 245) being a *free* reed.

A reed is used in a similar way in the mouthpiece of the oboe, saxophone and other instruments of that class.

In the automobile 'honk' (Fig. 247) a striking reed is used. It is inserted at *r*, where the flexible tube joins on the brass portion. On pressing the bulb the reed sets in vibration the air column in the brass portion.

239. Instruments in Which the Vibrations are Produced by Player's Lips. These all consist essentially of an open conical tube, the larger end terminating in a bell while at the smaller end is a cup, carrying a rounded edge, against which the tense lips of the player are steadily pressed. The lips thus constitute a reed and by their vibrations waves are set up in the air within the tube.

In this way the fundamental and the various harmonics of the air column in the tube are produced, and all but the extreme bass sounds are used in the scale.

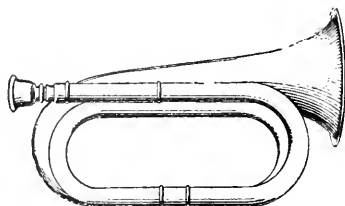

FIG. 248.—The Bugle.

In the French horn the total length of tube is about 17 feet, and hence the fundamental note is very deep. The production of the harmonic series depends entirely on the varied tension of the lips.

The bugle is illustrated in Fig. 248. The length of tube is fixed, and the notes producible are the fundamental and about 5 overtones. Its compass is much smaller than that of the French horn.

In the cornet, by means of three valves *a*, *b*, *c* (Fig. 249), the air column may be divided into different lengths, and a series of overtones is obtained with each length.

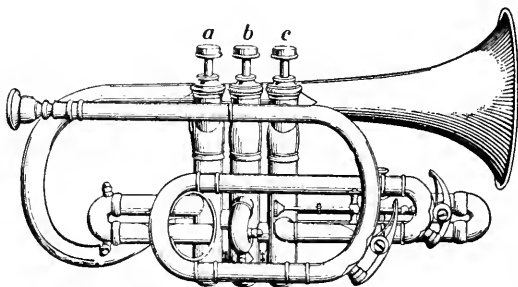

FIG. 249.—By the valves *a*, *b*, *c*, the air column is divided into different lengths.

In the trombone, on the other hand, besides obtaining overtones by suitable blowing, the pitch is varied by altering the

length of the tube. This is done by means of a U-shaped portion, *AB* (Fig. 250), which can slide with gentle friction

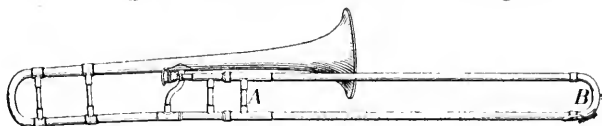

FIG. 250.—A slide trombone.

upon the body of the instrument.

240. The Phonograph. This instrument, now so familiar, was invented by Edison in 1877. Its construction, like that of the telephone receiver, is extremely simple, and one is astonished that such wonderful results can be obtained in so simple a manner.

A cylinder (*C*, Fig. 251), of comparatively hard wax is made (usually by clockwork), to rotate and at the same time move parallel to its axis. Resting on this is a sharp steel point (*P*, Fig. 252), attached to a thin diaphragm, which covers the lower end of the cone, *R*. In this way, as the cylinder rotates, a long spiral groove is scratched on its surface.

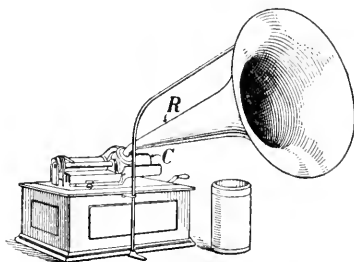

FIG. 251.—The phonograph. *C* is the cylinder on which the spiral groove is made. A cylinder is shown (enlarged) beside the instrument.

Sounds are spoken or sung into the cone, which collects them and leads them to the diaphragm. The varying pressures of the waves cause this to move back and forth, alternately increasing and decreasing the pressure of the point upon the wax. In this way hollows of different depths and forms are carved at the bottom of the groove.

If now the point* is made to run along the groove again the diaphragm will execute precisely the same motions once more, the motion will be imparted to the air and thus the original sound will be reproduced with surprising fidelity.

In place of the cylinder a disc may be used; and by suitable processes duplicates of the cylinder or the disc can be made in more permanent substance than the original wax.

* Different cones and points are used for recording and reproducing the sounds.

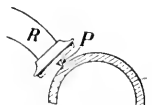

FIG. 252.—Point and diaphragm of the phonograph.

PART VI—HEAT

CHAPTER XXIV

NATURE AND SOURCE OF HEAT

241. Nature of Heat. It is a matter of every day experience that when motion is checked by friction or collision, heat is developed in the bodies concerned. Thus if a button is rubbed vigorously on a piece of cloth it may be made too hot to be handled. A drill used in boring steel quickly becomes heated. A leaden bullet shot against an iron target may be melted by the impact. The aborigines obtained fire by rubbing two dry sticks together.

From very early times such effects were supposed to be due to a subtle imponderable fluid which entered the bodies, and produced the various phenomena of heat. Although certain philosophers, notably Descartes, Boyle, Francis Bacon and Newton, evidently had in a vague way anticipated the theory of heat as a mode of motion, yet the conception of heat as a material agent was generally accepted up to the beginning of the nineteenth century.

The first serious attack upon the theory was made by Count Rumford,* in 1798. In this he was supported by Sir Humphry Davy and others during the early years of the last century, but it was near the middle of the century before the modern dynamical theory of heat was firmly established. It was then shown by Joule that a definite amount of mechanical work corresponds to a definite quantity of heat, from which it is manifest that heat must be a form of energy.

* Benjamin Thompson was born at Woburn (near Boston, Mass.) in 1753. In 1775 he went to England and in 1783 to Austria. He was created Count Rumford by the Elector of Bavaria. While engaged in boring cannon at Munich he made his experiments on heat. He died in France in 1814.

There would appear to be in each of the illustrations given above a loss in energy due to the loss in velocity of the body whose motion is checked, but, according to the modern view of heat, the loss is only apparent, not real. The energy which disappears as onward motion re-appears as increased molecular motion. To be definite, *heat is a form of energy possessed by a body in virtue of the motion of its molecules.*

242. Sources of Heat. Since heat is a form of energy it must be derived from some other form of energy. The process of the development of heat is a transformation of energy.

243. Heat from Friction, Percussion and Compression. We have already noted that heat is produced when onward motion is arrested through friction or percussion. It is also developed by compression. If a piece of dry tinder is placed in a tube closed at one end containing air, and a closely-fitting piston is pushed quickly into the tube (Fig. 253), the tinder may be lighted by the heat developed by the compression of the air. The cylinders of air-compressors (a bicycle pump for instance) become heated by the repeated compression of the air drawn into them.

Conversely, if a compressed gas is allowed to expand its temperature falls. The steam which has done work by its expansion in driving forward the piston of a steam engine escapes from the cylinder at a lower temperature than that at which it entered it.

244. Heat from Chemical Action. The potential energy of chemical separation is one of our most common sources of heat. Combustible bodies, such as coal and wood, possess energy of this kind. When raised to the ignition point they unite chemically with the oxygen of the air, and their union



FIG. 253.—Fire Syringe.

is accompanied by the development of heat. So far this has been the chief source of artificial heat used for cooking our food and warming our dwellings.

245. Heat from an Electric Current. When an electric current is made to pass through a conductor which offers resistance to it, heat is developed. For example, if the terminals of a battery consisting of three or four galvanic cells joined in series are connected with a short piece of fine platinum or iron wire, it will be heated to a white heat. Electric lamps also furnish examples of this transformation of energy, the source of the radiation in them being bodies heated to incandescence by an electric current. Electric heaters and electric cookers in their simplest forms are but coils of resistance wire heated by an electric current.

246. Heat from Radiant Energy. "The sun is our source of natural heat," but the heat is natural only in the sense that it comes from our most abundant source of supply. The heat does not, as we might at first suppose, come unchanged from the sun to the earth. The air extends to but a relatively short distance above the earth, and it is certain that matter, as we understand it, constituted of molecules, cannot extend throughout space. The direct transference of molecular motion from the sun to the earth is, therefore, an impossibility. To account for the transmission of energy the physicist assumes the existence of a medium called the ether, which he conceives to pervade all space, intermolecular as well as interstellar. The vibrating molecules of a hot body cause disturbances in the ether, which are transmitted in all directions by a species of wave-motion. When the ether waves fall upon matter, they tend to accelerate the motion of its molecules. According to this theory the heat of the sun is first changed into *radiant energy*, or the energy of ether vibration, and the ether waves which fall upon the earth are transformed into heat. The subject is further discussed in §§ 325, 326.

CHAPTER XXV

EXPANSION THROUGH HEAT

247. Expansion of Solids by Heat. In discussing the molecular constitution of matter we saw (§ 153) that one effect of the application of heat to a body is to cause it to expand. The theoretical explanation was discussed at some length, and need not be again referred to here. Moreover, examples of the expansion of bodies through heat are so numerous and so commonly observed that fulness in

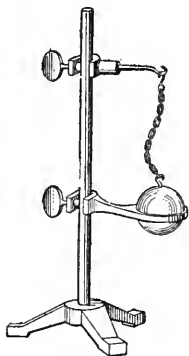

FIG. 254.—Expansion of ball by heat.

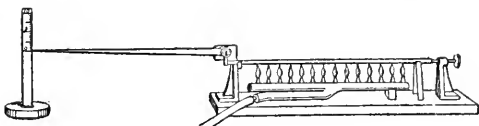

FIG. 255.—Expansion of rod by heat.

illustration is unnecessary. If a brass ball (Fig. 254) which can just pass through a ring when cold is heated it will then be found to be too large to go through. If we heat a metal rod which is fixed at one end while the other is made to press against the short arm of a bent lever (Fig. 255) an elongation of the rod is shown by a movement of the end of the long arm over a scale. When a compound bar, made by riveting together strips of copper and iron (Fig. 256) is heated uniformly it bends into the form of an arc of a circle with the copper on the convex side, because the copper

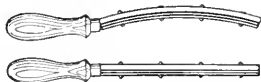

FIG. 256.—Bending of compound bar by unequal expansion of its parts.

is heated uniformly it bends into the form of an arc of a circle with the copper on the convex side, because the copper

expands more than the iron. If placed in a cold bath it curves in the opposite direction.

These experiments illustrate a very general law. Solids with very few exceptions expand when heated and contract when cooled, but different solids have different rates of expansion.

248. Expansion of Liquids and Gases by Heat. Liquids also expand when heated. The amount of expansion varies

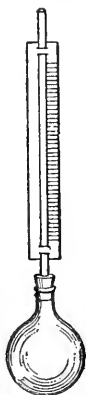

FIG. 257.—Expansion of liquids by heat.

with the liquid, but on the whole, it is much greater than that of solids. Let us enclose a liquid within a flask and connected tube, as shown in Fig. 257, and heat the flask. The liquid is seen to rise in the tube

The same apparatus may be used to illustrate the expansion of gases. When the flask and tube are filled with air only, insert the open end of the tube into water (Fig. 258), and heat the flask. A portion of the air is seen to bubble out through the water. If the flask is cooled, water is forced by the pressure of the outer air into the tube to take up the space left by the air as it contracts.

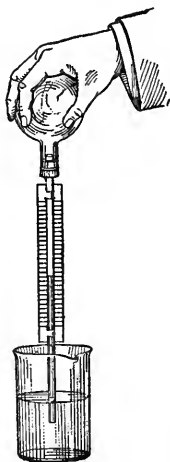

FIG. 258.—Expansion of gas by heat.

Unlike solids and liquids, all gases have, at the ordinary pressure of the air, approximately the same rates of expansion.

249. Applications of Expansion—Compensated Pendulums. A clock is regulated by a pendulum, whose rate of vibration depends on its length. The longer the pendulum, the

slower the beat; and the shorter, the faster. Changes in temperature will therefore cause irregularities in the running of the clock, unless some provision is made for keeping the pendulum constant in length through varying changes in temperature. Two forms of compensation are in common use. The Graham pendulum (Fig. 259) is provided with a bob consisting of a jar of mercury. Expansion in the rod lowers the centre of gravity of the bob, while expansion in the mercury raises it. The quantity of mercury is so adjusted as to keep the centre of gravity* always at the same level.



FIG. 259.—Graham pendulum.

In the Harrison, or gridiron pendulum (Fig. 260) the bob hangs from a framework of brass and steel rods, so connected that an increase in length of the steel rods (dark in the figure), tends to lower the bob, while an increase in the length of the brass ones tends to raise it. The lengths of the two sets are adjusted to keep the resultant length of the pendulum constant.



FIG. 260.—Harrison pendulum.

250. Chronometer Balance Wheel. A watch is regulated by a balance wheel, controlled by a hair-spring (Fig. 261). An increase in temperature tends to increase the diameter of the wheel and to decrease the elasticity of the spring. Both effects would cause the watch to lose time. To counteract the retarding effects, the rim of the balance wheel in chronometers and high-grade watches is constructed of two metals and mounted in sections, as shown

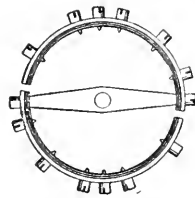

FIG. 261.—Balance wheel of watch.

*Strictly speaking, it is a point called the *centre of oscillation* (which nearly coincides with the centre of gravity) whose distance from the point of suspension should be kept constant.

in Fig. 261. The outer metal is the more expansible, and the effect of its expansion is to turn the free ends of the rim inwards, and thus to lessen the effective diameter of the wheel.

251. Thermostats. The fact that a bar composed of two metals having unequal expansion tends to curl up with increased temperature finds practical application also in the construction of thermostats.

Thermostats are used mainly for controlling the temperature in buildings heated by hot-air furnaces or boilers. In most

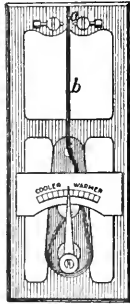

FIG. 262.—An electric thermostat.

systems of control, dampers or steam valves are opened and closed by electricity or compressed air. The object of the thermostat is to set free the current of electricity or the compressed air to close the valves or dampers when the temperature reaches a certain point.

Fig. 262 shows an electric thermostat and Fig. 263

shows a pneumatic thermostat. The essential part of each is the same, the compound bar *b*. On the electric thermostat, the bending of the bar by heat closes the electric current at *a*. On the pneumatic thermostat, the bending of the bar closes a small aperture at *a* through which the compressed air escapes slowly by a by-pass. The air thus held back enters the bellows *c*, which on expanding opens a valve and this allows the main current of compressed air to have access to the regulators in the furnace room.

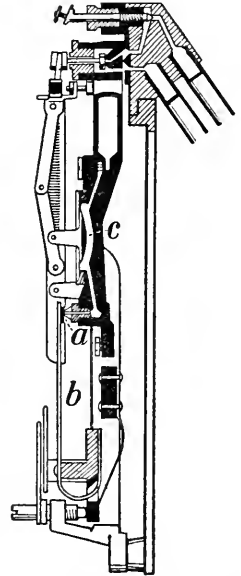

FIG. 263.—A pneumatic thermostat.

QUESTIONS

1. A glass stopper stuck in the neck of a bottle may be loosened by subjecting the neck to friction by a string. Explain.
2. Boiler plates are put together with red-hot rivets. What is the reason for this?
3. Why does a blacksmith heat a wagon-tire before adjusting it to the wheel?
4. Why are the rails of a railroad track laid with the ends not quite touching?
5. Why does change in the temperature of a room affect the tone of a piano?
6. Glass vessels are liable to break when suddenly heated or cooled in one part only. Give the reason.

CHAPTER XXVI

TEMPERATURE

252. Nature of Temperature. When the blacksmith throws the red-hot iron into a tub of cold water to cool it, the iron evidently loses heat, while the water gains it. When two bodies like the iron and water are in such a condition that one grows warmer and the other colder when they are brought in contact, they are said to be at different temperatures. The body which gains heat is said to be at a lower temperature than the one which loses it. If neither grows warmer when the bodies are brought together, they are said to be at the same temperature. *Temperature*, therefore, may be defined as *the condition of a body considered with reference to its power of receiving heat from, or communicating heat to, another body.*

253. Temperature and Quantity of Heat. A pint of water taken from a vat is at the same temperature as a gallon taken from the same source. They will also be at the same temperature when both are brought to the boiling point, but if they are heated by the same gas flame, it will take much longer to bring the gallon up to the boiling point than to raise the pint to the same temperature. The change in temperature is the same in each, but the *quantity of heat* absorbed is different. A large radiator, filled with hot water may, in cooling, supply sufficient heat to warm up a room, but a small pitcher of water loses its heat with no apparent effect. The quantity of heat possessed by a body evidently depends on its mass as well as its temperature.

254. Determination of Temperature. Up to the time of Galileo, no instrumental means of determining temperature had been devised. Differences in the temperature of bodies were estimated by comparing the sensations resulting from

contact with them. But simple experiments will show that our temperature sense cannot be relied upon to determine temperature with any degree of accuracy. Take three vessels, one containing water as hot as can be borne by the hand, one containing ice-cold water, and one with water at the temperature of the room. Hold a finger of one hand in the cold water and a finger of the other in the hot water for one or two minutes, and immediately insert both fingers in the third vessel. To one finger the water will appear to be hot, and to the other, cold. The experiment shows that our estimation of temperature depends, to a certain extent, on the temperature of the sensitive part of the body engaged in making the determination. Our ordinary experiences confirm this conclusion. If we pass from a cold room into one moderately heated, it appears warm, while the room at the same temperature appears cold when we enter it from one that has been overheated.

Again, our estimation of the temperature of a body depends on the nature of the body as well as upon its temperature. It is a well-known fact that on a very cold day a piece of iron exposed to frost feels much colder than a piece of wood, although both may be at the same temperature.

255. Galileo's Thermometer. So far as known, Galileo was the first to construct a thermometer. He conceived that since changes in the temperature of a body are accompanied by changes in its volume, these latter changes might be made to measure, indirectly, temperature. He selected air as the body to be employed as a thermometric substance.

His thermometer consisted simply of a glass bulb with a long, slender, glass stem made to dip into water, as shown in Fig. 264. By warming the bulb, a few bubbles

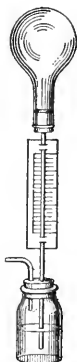

FIG. 264.—Galileo's air thermometer.

of air were driven out of the stem, and on cooling the bulb the water rose part way up the stem. Any increase in temperature was then shown by a fall of the water in the tube, and a decrease by a rise. Such a thermometer is imperfect, as the height of the column of liquid is affected by changes in the pressure of the outside air, as well as by changes in the temperature of the air within the bulb. According to Viviani, one of Galileo's pupils, 1593 was the date of the invention of the instrument.

256. Improvements on the Thermometer. About forty years later, Jean Rey, a French physician, improved the instrument by making use of water instead of air as the expansible substance. The bulb and a part of the stem were filled with water. Further improvements were made by the Florentine academicians, who made use of alcohol instead of water, sealed the tube, and attached a graduated scale. The first mercury thermometer was constructed by the astronomer, Ismaël Boulliau, in 1659.

257. Construction of a Mercury Thermometer. Alcohol is still used to measure very low temperatures, but mercury is now found in most thermometers in common use. This liquid has been selected for a variety of reasons. Among others, the following may be noted.

It can be used to measure a fairly wide range of temperatures, because it freezes at a low temperature and boils at a comparatively high temperature. At any definite temperature it has a constant volume. Slight changes in temperature are readily noted, as it expands rapidly with a rise in temperature. It does not wet the tube in which it is enclosed.

To construct the thermometer a piece of thick-walled glass tubing with a uniform capillary bore is chosen, and a bulb is blown at one end. Bulb and tube are then filled with mercury. This is done by heating the bulb to expel part of

the air, and then dipping the open end of the tube into mercury. As the bulb cools, mercury is forced into it by the pressure of the outside air. The liquid within the bulb is boiled to expel the remaining air, and the end of the tube is again immersed in mercury. On cooling, the vapour condenses and bulb and tube are completely filled with mercury. The tube is then sealed off.

258. Determination of the Fixed Points. Since we can describe a particular temperature only by stating how much it is above or below some temperature assumed as a standard, it is necessary to fix upon standards of temperature and also units of difference of temperature. This is most conveniently done by selecting two fixed points for a thermometric scale. The standards in almost universal use are the "freezing point" and the "boiling point" of water.

To determine the freezing point, the thermometer is surrounded with moist pulverized ice (Fig. 265), and the point at which the mercury stands when it becomes stationary is marked on the stem.

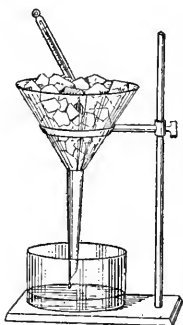

Fig. 265. — Determination of freezing point.

The boiling point is determined by exposing the bulb and stem to steam rising from pure water boiling under a pressure of 76 cm. of mercury

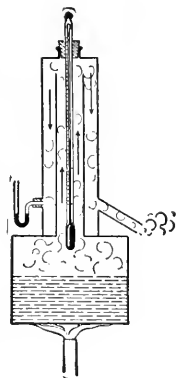

Fig. 266. — Determination of boiling point.

(Fig. 266). As before, the height of the mercury is marked on the stem.

259. The Graduation of the Thermometer. Having marked the freezing and boiling points, the next step is to graduate the thermometer. Two scales are in common use, the Centigrade scale and the Fahrenheit scale.

The Centigrade scale, first proposed by Celsius, a Swedish scientist, in 1740, and subsequently modified by his colleague Mårten Strömer, is now universally employed in scientific work. The space intervening between the freezing point and the boiling point is divided into one hundred equal divisions, or degrees, and the zero of the scale is placed at the freezing point, the graduations being extended both above and below the zero point.*



FIG. 267.—Thermometer scales.

The Fahrenheit scale is in common use among English-speaking people for household purposes. It was proposed by Gabriel Daniel Fahrenheit (1686-1736), a German instrument maker. The space between the freezing point and the boiling point is divided into one hundred and eighty equal divisions, each called a degree, and the zero is placed thirty-two divisions below the freezing point. The freezing point, therefore, reads 32° and the boiling point 212° (Fig. 267). This zero point was chosen, it is said, because Fahrenheit believed this temperature, obtained from a mixture of melting ice and ammonium chloride or sea-salt, to be the lowest attainable.

260. Comparison of Thermometer Scales. If the temperature of the room at the present moment is 68° , the temperature is $68 - 32$, or 36 degrees above the freezing point; but since 180 Fahrenheit degrees = 100 Centigrade degrees, or 9 Fahrenheit degrees = 5 Centigrade degrees, the temperature of the room is $\frac{5}{9}$ of 36, or 20 Centigrade degrees above the freezing point; that is, the Centigrade thermometer will read 20° .

The relation between corresponding readings on the two thermometers may be obtained in the following way. Let a

* Celsius at first marked the boiling-point zero and the freezing-point 100. It is said that the great botanist Linnaeus prompted Celsius and Strömer to invert the scale.

certain temperature be represented by F° on the Fahrenheit and C° on the Centigrade scale. Then this temperature is $F - 32$ Fahrenheit degrees above the freezing point, and it is also C Centigrade degrees above the freezing point. Hence

$(F - 32)$ Fahr. degrees correspond to C Cent. degrees.

But 9 Fahr. degrees correspond to 5 Cent. degrees,

Therefore $\frac{5}{9}(F - 32) = C$.

261. Maximum and Minimum Thermometers. A maximum thermometer is one which records the highest temperature reached during a certain time. One form is shown in Fig. 268. It is a mercury thermometer with a constriction fixed in the tube just above the bulb (c , Fig. 268). As the temperature rises the mercury expands and goes past the constriction; but when it contracts the thread breaks at the constriction, that portion below it contracting into the bulb, while the mercury in the tube remains in the position it had when the temperature was highest. By gently tapping or shaking the thermometer the mercury can be forced past the constriction, ready for use again.



FIG. 268.—A maximum thermometer (as used in the Meteorological Service).

The clinical thermometer, with which the physician takes the temperature of the body, is constructed in this way.

In another kind of maximum thermometer a small piece of iron is inserted in the stem above the mercury (Fig. 269), and is pushed forward as the mercury expands. When the mercury contracts the iron is left behind and thus indicates the highest point reached by the mercury.



FIG. 269.—The iron index is pushed forward by the mercury.

In the minimum thermometer, which registers the lowest temperature reached, alcohol is used. Within the alcohol a small glass index is placed (Fig. 270). As the alcohol contracts, on account of its surface tension (§ 169) it drags the index back, but when it expands it flows past the index which is thus left stationary and shows the lowest temperature reached. By tilting the thermometer the index slips down to the surface of the alcohol column, ready for use again.



FIG. 270.—A minimum thermometer (as used in the Meteorological Service). It is hung in a horizontal position.

PROBLEMS

1. To how many Fahrenheit degrees are the following Centigrade degrees equivalent :—5, 18, 27, 65 ?
2. To how many Centigrade degrees are the following Fahrenheit degrees equivalent :—20, 27, 36, 95 ?
3. How many Fahrenheit degrees above freezing point is 65° C.?
4. How many Centigrade degrees above freezing point is 60° F.?
5. Convert the following readings on the Fahrenheit scale to Centigrade readings :— 0° , 10° , 32° , 45° , 100° , -25° , and -40° .
6. Convert the following readings on the Centigrade scale to Fahrenheit readings :— 10° , 20° , 32° , 75° , -20° , -40° , and -273° .
7. Find in Centigrade degrees the difference between 30° C. and 16° F.
8. In the Réaumur scale, (which is used for household purposes in some countries of Europe), the freezing point is marked 0° and the boiling point 80° . Express
 - (a) 12° C., -10° C., 5° F., 36° F. in the Réaumur scale.
 - (b) 16° R., 25° R., -6° R. in both the Centigrade and the Fahrenheit scale.

CHAPTER XXVII

RELATION BETWEEN VOLUME AND TEMPERATURE

262. Coefficient of Expansion of Solids. We have seen (§ 247) that a rise in the temperature of a body is usually accompanied by an increase in its dimensions, and that different substances have different rates of expansion. In the case of solids we are usually concerned with change in length, while with liquids and gases it is chiefly change of volume which we have to consider.

The COEFFICIENT OF LINEAR EXPANSION may be defined as the *increase in length experienced by a rod of unit length when its temperature is raised one degree.*

Let l_1 be the first length of a rod and t_1° its temperature. Raise the temperature to t_2° and let the length then be l_2 . The total increase in length is $l_2 - l_1$ for a rise of $t_2 - t_1$ degrees in temperature, and so the increase for one degree = $\frac{l_2 - l_1}{t_2 - t_1}$. But this is the increase in length of a rod whose length at first was l_1 .

Hence the increase per unit length per degree = $\frac{l_2 - l_1}{l_1(t_2 - t_1)}$.

This is the coefficient of linear expansion, and to determine it we must measure l_1 , l_2 , t_1 , t_2 and put them in this expression. As the change in length is always small it must be measured with accuracy. This may be done as follows:—A long, straight bar of the substance, whose coefficient is to be determined, is taken and a fine line drawn across it near each end. The bar is then supported in a bath, the temperature of which can be determined, and changed at will. By means of a micrometer-microscope and a scale, the distance between the marks is measured when the bar is at the initial temperature. The bath is then heated. When the temperature of the whole is again steady, the distance between the marks is again measured and the temperature noted. Data are thus furnished for calculating the coefficient of linear expansion of the metal.

The following table gives the coefficients of linear expansion of some common substances. The volume coefficient of expansion of a solid is usually determined by a calculation from the linear coefficient.

COEFFICIENTS OF LINEAR EXPANSION FOR 1° C.

Substance.	Coefficient.	Substance.	Coefficient.
Aluminium.....	0.00002313	Nickel.....	0.00001279
Brass.....	0.00001900	Platinum.....	0.00000899
Copper.....	0.00001678	Silver.....	0.00001921
Glass.....	0.00000899	Steel.....	0.00001322
Gold.....	0.00001443	Tin.....	0.00002234
Iron (soft).....	0.00001210	Zinc.....	0.00002918

An alloy of nickel and steel (36 per cent. of nickel) known as "invar," has a coefficient of expansion only one-tenth that of platinum.

263. Coefficient of Expansion of Liquids. Like solids, different liquids expand at different rates. Many liquids also are very irregular in their expansion, having different coefficients at different temperatures.



FIG. 271.—Determination of the coefficient of expansion of a liquid.

The coefficient of expansion of a liquid may be determined with a fair degree of accuracy by a modification of the experiment described in § 248. The liquid is enclosed in a bulb and graduated capillary tube, shown in Fig. 271. The bulb is heated in a bath, and the position of the surface of the liquid in the tube corresponding to various temperatures is noted. Now, if the volume of the bulb in terms of the divisions of the stem is known, the expansion can be calculated. To be accurate, corrections should be made for changes

in the capacities of the bulb and tube through changes in temperature.

264. Peculiar Expansion of Water ; its Maximum Density. If the bulb and tube shown in Fig. 271 is filled with water at the temperature of the room—say 20° C.—and the bulb placed in a cooling bath, the water will regularly contract in volume until its temperature falls to 4° C., and then it will expand until it comes to the freezing point. Conversely, if water at 0° C. is heated it will contract in volume until it reaches 4° C., and then it will expand.* Hence, a given mass of water has minimum volume and maximum density when it is at 4° C.

An experiment devised by Hope shows in a simple manner that the maximum density of water is at 4° C. A metal reservoir is fitted about the middle of a tall jar, and two thermometers are inserted, one at the top and the other at the bottom, as shown in Fig. 272. The jar is filled with water at the temperature of the room, and a freezing mixture of ice and salt is placed in the reservoir. The upper thermometer remains stationary and the lower one continues to fall until it indicates a temperature of 4° C. The lower one now remains stationary and the upper one begins to fall and continues to do so until it reaches the freezing point.

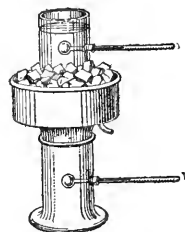

FIG. 272.—Hope's apparatus.

The experiment shows that as the water about the centre of the jar is cooled it becomes denser and continues to descend until all the water in the lower part of the jar has reached the maximum density. On further cooling the water in the middle of the jar it becomes lighter and ascends.

The experiment illustrates the behaviour of large bodies of water in cooling as winter approaches. As the surface layers

* In an actual experiment the contraction of the glass must be allowed for.

cool they become denser and sink, while the warmer water below rises to the top. This process continues until the whole mass of water reaches a uniform temperature of 4°C . The colder and lighter water then remains on the surface, where the ice forms, and this protects the water below.

PROBLEMS

1. A steel piano wire is 4 feet long at a temperature of 16°C . What is its length at 20°C .?

2. A brass scale is exactly one metre long at 0°C . What is its length at 18°C .?

3. A pane of glass is 12 inches long and 10 inches wide at a temperature of 5°C . What is the area of its surface at 15°C .?

4. The bars in a gridiron pendulum are made of iron and copper. If the iron bars are 80 cm. long, what should be the length of the copper bars?

5. The height of the mercury column in a barometer was 760 mm. when the temperature was 0°C . What would be the height at 20°C ., being given that the volume-coefficient of expansion of mercury is 0.000187? If the height was observed by means of a brass scale which was correct at 0°C ., what would be the apparent reading on the scale?

6. At temperature 15°C . the barometric height is 763 mm. as indicated by a brass scale which is correct at 0°C . What would be the reading if the temperature fell to 0°C .?

7. Explain where the ice would form and what would happen if water continued to contract down to 0°C ., (1) if solidification produced the same expansion as it does now; (2) if contraction accompanied freezing.

265. Coefficient of Expansion of Gases—Charles' Law. It has been shown by the experiments of Charles, Gay-Lussac, Regnault,* and other investigators, that under constant pressure all gases expand equally for equal increases in temperature. In other words, all gases have approximately the same coefficient of expansion. Further, it was shown by Charles, that under constant pressure the volume of a given mass of gas increases by a constant fraction of its volume at 0°C . for each increase of 1°C . in its temperature. Charles roughly determined this ratio, which was afterwards more accurately measured by Gay-Lussac, whose researches were published in 1802.

* Charles (1746-1823), Gay-Lussac (1778-1850), Regnault (1810-1878) were all French scientists.

The general statement of the principle is usually known as CHARLES' LAW, but sometimes as *Gay-Lussac's Law*. It is given in the following statement:—*The volume of a given mass of any gas at constant pressure increases for each rise of 1° C. by a constant fraction (about $\frac{1}{273}$) of its volume at 0° C.*

It has also been shown that if the volume remains constant, the pressure of a given mass of gas increases by the same constant fraction (about $\frac{1}{273}$) of its pressure at 0° C. for each rise in temperature of 1° C. That is to say, the volume-coefficient, and the pressure-coefficient of a gas are numerically equal. Practically, this is but a statement, in other terms, of the fact that, in obeying Charles' Law, gases also obey Boyle's Law.

The volume-coefficient and the pressure-coefficient may be determined experimentally by the apparatus devised by Regnault (Fig. 273). The gas is inclosed in the bulb *N*, whose volume is known. The bulb is placed first in melting ice, and then in steam rising from boiling water, the pressure being kept constant by keeping constant the difference in level of the mercury in the tubes *A* and *B*. The increase in volume is calculated by the change in height in the mercury column in *A*. Given the volume of the bulb and the tube, and having determined the increase in volume for a change in temperature from 0° to 100°, the expansion-coefficient is found by a simple calculation.

To determine the pressure-coefficient the bulb, as before, is placed alternately in melting ice, and in steam. The volume

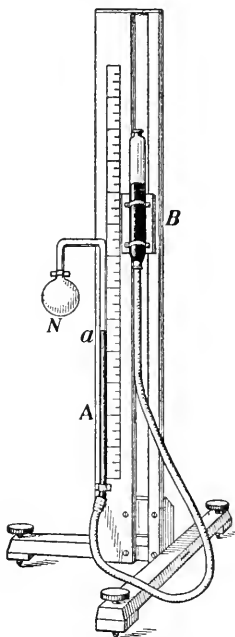

FIG. 273.—Regnault's apparatus for finding the coefficient of expansion of a gas.

is kept constant by keeping the surface of the mercury in the tube A at a fixed level a . This is done by adjusting the height of the mercury column in B . The increase in pressure is measured by the increased difference in the level in the mercury columns in A and B .

266. Gas Thermometer. The Regnault apparatus is used as a gas thermometer. The bulb is filled with a gas, usually hydrogen. The position of the mercury level in B is marked 0° when the bulb is in melting ice and the surface of mercury in A is at a fixed point a ; it is marked 100° when the bulb is in steam and the mercury level in A is at the same fixed point. The space between 0° and 100° is divided into 100 equal divisions, and these are continued below 0° and above 100° . To use the instrument the tube B is adjusted to bring the mercury level in A to the fixed point a , and the temperature is read directly from the scale placed behind B .

In the gas thermometer changes in temperature are measured, not as in the thermometers already described, by the changes in volume, but by the corresponding changes in pressure when the volume is kept constant.

The nitrogen gas thermometer is the most perfect instrument of its kind. It has been chosen by the International Bureau of Weights and Measures as the standard for temperature measurement. For convenience, mercury thermometers are employed for most purposes. The gas thermometer is used mainly for standardizing mercury thermometers and for measuring very low and very high temperatures.

267. Absolute Temperature. In the gas thermometer the volume of the gas is kept constant, while a change in the temperature is determined by the change in the pressure which the gas exerts.

Let the gas at first be at 0° C. If its temperature is raised to 1° C. its pressure will increase $\frac{1}{273}$, that is, at 1° C. the

pressure will be $\frac{2}{3} \frac{7}{13}$ of that at 0° C. At 2° C. the pressure exerted by the gas will be $\frac{2}{3} \frac{7}{13}$; at 100° C. the pressure will be $\frac{2}{3} \frac{7}{13}$ of that at 0° C.; and so on.

Again, at -1° C. the pressure will be diminished $\frac{1}{273}$, that is, the gas will exert a pressure $\frac{2}{3} \frac{7}{13}$ of that at 0° C.; at -2° C. the pressure will be $\frac{2}{3} \frac{7}{13}$; at -20° C. it will be $\frac{2}{3} \frac{5}{13}$; and so on.

If we could continue lowering the temperature and reducing the pressure in this same way, then at -273° C. the pressure would be nothing. But before reaching such a low temperature the gas will change to a liquid, and our method of measuring temperature by the pressure of the gas would then fail.

However, calculations based on the kinetic theory of gases (§ 151) lead to the conclusion that at -273° C. the rectilinear motions of the molecules would cease; which would mean that the substance was completely deprived of heat and at the lowest possible temperature. This point is hence called the *absolute zero*, and temperature reckoned from it is called *absolute temperature*. Thus a Centigrade reading can be converted into an Absolute reading by adding 273 to it.

The method of measuring temperature on an absolute scale was proposed by Lord Kelvin in 1848.



LORD KELVIN (SIR WILLIAM THOMSON) (1824-1907). Made important investigations in almost every branch of physics. Famous as electrician of Atlantic cables.

268. Further Statement of Charles' Law. Let V_0 , V_1 , V_2 , etc., represent the volumes of a given mass of gas, under constant pressure, at temperatures, respectively, 0° , 1° , 2° , etc., C.,

that is, 273° , 274° , 275° , etc., Absolute, then according to Charles' Law

$$\begin{aligned} V_0 : V_1 : V_2 : \text{etc.}, &= \frac{2}{2} \frac{7}{7} \frac{3}{3} V_0 : \frac{2}{2} \frac{7}{7} \frac{4}{3} V_0 : \frac{2}{2} \frac{7}{7} \frac{5}{3} V_0 : \text{etc.} \\ &= 273 : 274 : 275 : \text{etc.} \end{aligned}$$

Stating this result in words, *the volume of a given mass of gas at a constant pressure varies directly as the absolute temperature.*

This manner of stating the law is often convenient for purposes of calculation.

PROBLEMS

1. If the absolute temperature of a given mass of gas is doubled while the pressure is kept constant, what change takes place in (a) its volume, (b) its mass, (c) its density ?

2. The pressure of a given mass of gas was doubled while its volume remained constant. What change must have taken place in (a) its absolute temperature, (b) its density ?

3. The pressure remaining constant, what volume will a given mass of gas occupy at 75° C. if its volume at 0° C. is 22.4 litres ?

4. If the volume of a given mass of gas is 120 c.c. at 17° C., what will be its volume at -13° C. ?

5. A gauge indicates that the pressure of the oxygen gas in a steel gas tank is 150 pounds per square inch when the temperature is 20° C. Supposing the capacity of the tank to remain constant, find the pressure of the gas at a temperature of 30° C.

6. An empty bottle, open to the air, is corked when the temperature of the room is 18° C. and the barometer indicates a pressure of 15 pounds per square inch. Neglecting the expansion of the bottle, find the pressure of the air within it after it has been standing for some time in a water bath whose temperature is 67° C.

7. An uncorked flask contains 1.3 grams of air at a temperature of -13° C. What mass of air does it contain at a temperature of 27° C. if the pressure remains constant ?

8. The volume of a given mass of gas is one litre at a temperature of 5° C. The pressure remaining constant, at what temperature will its volume be (a) 1100 c.c., (b) 900 c.c. ?

9. At what temperature will the pressure of the air in a bicycle tire be 33 pounds to the square inch, if its pressure at 0° C. is 30 pounds per square inch? (Assume no change in volume.)

10. A certain mass of hydrogen gas occupies a volume of 380 c.c. at a temperature of 12° C. and 80 cm. pressure. What volume will it occupy at a temperature of -10° C. and a pressure of 76 cm.?

(1) Change in volume for change in temperature.

Since the volume varies directly as the absolute temperature and the temperature is reduced from 12° C. to -10° C. the volume will be reduced to become $\frac{273}{273-12} = \frac{261}{273}$ or $\frac{261}{273}$ of the original volume.

(2) Change in volume for change in pressure.

Since the volume varies inversely as the pressure, and the pressure is reduced from 80 cm. to 76 cm. the volume will be increased to become $\frac{80}{76}$ of the original volume.

Hence, taking into account the changes for both temperature and pressure, the volume required will be,

$$380 \times \frac{261}{273} \times \frac{80}{76} = 369.12 \text{ c.c.}$$

11. A mass of oxygen gas occupies a volume of 120 litres at a temperature of 20° C. when the barometer stands at 74 cm. What volume will it occupy at standard temperature and pressure? (0° C. and 76 cm. pressure.)

12. The volume of a certain mass of gas is 500 c.c. at a temperature of 27° C. and a pressure of 400 grams per sq. cm. What is its volume at a temperature of 17° C. and a pressure of 600 grams per sq. cm.?

13. The weight of a litre of air at standard temperature and pressure is 1.29 grams. Find the weight of 800 c.c. of air at 37° C. and 70 cm. pressure.

14. The density of hydrogen gas at standard temperature and pressure is 0.0000896 grams per c.c. Find its density at 15° C. and 68 cm. pressure.

CHAPTER XXVIII

MEASUREMENT OF HEAT

269. Unit of Heat. As already pointed out (§ 253), the *temperature* of a body is to be distinguished from the *quantity of heat* which it contains. The thermometer is used to determine the temperature of a body, but its reading does not give the quantity of heat possessed by it. A gram of water in one vessel may have a higher temperature than a kilogram in another, but the latter will contain a greater quantity of heat. Again, a pound of water and a pound of mercury may be at the same temperature, but we have reasons for believing that the water contains more heat.

In order to measure heat we must choose a suitable unit, and by common consent, the amount of heat required to raise by one degree the temperature of a unit mass has been selected as the most convenient one. The unit, will, of course, have different magnitudes, varying with the units of mass and temperature-difference chosen. In connection with the metric system the unit called the CALORIE has been adopted for scientific purposes. It is *the amount of heat required to raise a mass of one gram of water one degree Centigrade in temperature.*

For example,

to raise 1 gram of water through 1° C. requires 1 calorie,

to raise 4 grams of water through 5° C. requires 20 calories,

and to raise m grams of water from t_1° to t_2° C. requires $m(t_2 - t_1)$ calories.

In engineering practice, the British Thermal Unit (designated *B. T. U.*) is in common use in English-speaking countries. It is the quantity of heat required to raise one pound of water one degree Fahrenheit in temperature.

PROBLEMS

1. How many calories of heat must enter a mass of 65 grams of water to change its temperature from 10°C. to 35°C. ?
2. How many calories of heat are given out by the cooling of 120 grams of water from 85°C. to 60°C. ?
3. If 1400 calories of heat enter a mass of 175 grams of water what will be its final temperature, supposing the original to be 15°C. ?
4. A hot water coil containing 100 kilograms of water gives off 1,000,000 calories of heat. Neglecting the heat lost by the iron, find the fall in temperature in the water.
5. On mixing 65 grams of water at 75°C. with 85 grams at 60°C. , what will be the temperature of the mixture?

270. Thermal Capacity—Specific Heat. The amount of heat required to change a unit-mass of a substance through one degree in temperature varies with different substances. To illustrate, if we place equal masses of turpentine and water at the same temperature in similar beakers and add to each the same mass of hot water we shall find, on determining the temperature of the mixture with a thermometer, after stirring, that, although approximately the same number of calories of heat has been added to each, the increase in temperature of the turpentine mixture is greater than the increase in temperature of the water. Thus we find that more heat is required to raise a certain mass of water one degree than to warm the same mass of turpentine to the same extent.

Next, heat equal masses of water, aluminium (wire) and mercury to the same temperature by placing them in separate test-tubes immersed in a bath of boiling water (Fig. 274). Now provide three beakers containing equal masses of water at the temperature of the room, and pour the hot water into the first, the aluminium into the second, and the mercury into the third. After stirring, take the temperature in each case.

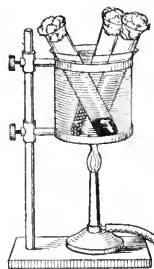

FIG. 274.—The heating of equal masses of different substances to the same temperature in a water bath.

The temperatures are quite different, the water in the first being the hottest, and the contents of the third being the coldest.

These experiments indicate that the amount of heat absorbed or given out by a body for a given change in temperature depends on the nature of the body, as well as upon its mass and change in temperature.

The number of heat units required to raise the temperature of a body one degree, is called its *thermal capacity*. The thermal capacity per unit-mass is called **SPECIFIC HEAT**. Specific heat, accordingly, may be defined as *the number of heat units required to raise the temperature of a unit-mass of the substance, one degree*.

Hence, the quantity of heat required to warm a mass of m grams of a substance from a temperature of t_1° to a temperature of $t_2^\circ = m(t_2 - t_1)s$, when s is the specific heat of the substance.

271. The Specific Heat of Water. From the definition of heat unit, it follows that the specific heat of water is 1; but, the heat required to warm a unit-mass one degree differs slightly with the temperature of the water.

Of all known substances except hydrogen, water has the greatest thermal capacity, which fact is of great importance in the distribution of heat on the surface of the earth. For example, land areas surrounded by large bodies of water are not so subject to extremes of temperature. In summer the water absorbs the heat, and as it warms very slowly, it remains cooler than the land. In winter, on the other hand, the water gradually gives up its store of heat to the land, thus preserving an equable temperature.

272. Determination of Specific Heat by the Method of Mixture. The method depends on the principle that the amount of heat lost by a hot body when placed in cold water is equal to the amount of heat gained by the water. Let us apply the method to find the specific heat of lead.

Take a definite mass of shot, say 220 grams, and heat it in steam from boiling water to a temperature of 100° C. (Fig. 275). Now place 100 grams of water at the temperature of the room, say 20° C., in a beaker and surround it with wool or batting to keep the heat from escaping. Pour the shot into the water and, after stirring, take the temperature. Let it be 25° C. Then the heat gained by the water

$$= 100 (25^{\circ} - 20^{\circ}) \text{ cal.} = 500 \text{ cal.}$$

If now no heat has escaped, 220 grams of lead must, in falling from 100° to 25° , have lost 500 cal. of heat. Or 1 gram of lead in falling 1° loses $500 \div (220 \times 75) = .030$ calories.

A general formula may be obtained as follows:—

Let m = the mass of the substance,

and t = its temperature ;

m_1 = the mass of the water,

and t_1 = its temperature.

Let t_2 = resulting temperature after mixing.

Then, heat gained by water = $m_1 (t_2 - t_1)$,

and heat lost by the substance = $m (t - t_2) s$, where s is its specific heat ;

Therefore $m (t - t_2) s = m_1 (t_2 - t_1)$,

$$\text{or } s = \frac{m_1 (t_2 - t_1)}{m (t - t_2)}$$

The method of mixture applies equally well to other substances than water, and to heat lost by water as well as gained by it.

SPECIFIC HEATS OF SOME COMMON SUBSTANCES

Aluminium.....	0.214	Ice (-10° C.)...	0.50	Paraffin.....	0.694
Brass.....	0.090	Iron.....	0.113	Petroleum.....	0.511
Copper.....	0.094	Lead.....	0.031	Platinum.....	0.032
Glass (crown)...	0.16	Marble.....	0.216	Silver.....	0.056
Gold.....	0.032	Mercury.....	0.033	Zinc.....	0.093

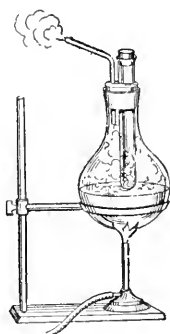

FIG. 275.—Determination of specific heat of a solid.

PROBLEMS

(For specific heats see table just above)

1. What is the thermal capacity of a glass beaker whose mass is 35 grams?
2. Which has the greater thermal capacity, 68 grams of mercury or 2 grams of water?
3. It requires 360 calories of heat to raise the temperature of a body 10 degrees. What is its thermal capacity?
4. The thermal capacity of 56 grams of copper is 5.264 calories. What is the specific heat of copper?
5. It requires 902.2 calories of heat to warm 130 grams of paraffin from 0° C. to 10° C. What is the specific heat of paraffin?
6. How much heat will a body whose thermal capacity is 320 calories lose in cooling from 40° to 10° C.?
7. What is the quantity of heat required to raise 120 grams of aluminium from 15° to 52° C.?
8. How many calories of heat are given off by an iron radiator whose mass is 25 kgs., in cooling from 100° to 20° C.?
9. A lead bullet whose mass is 12 grams had a temperature of 25° C. before it struck an iron target, and a temperature of 100° C. after impact. How many calories of heat were added to the bullet?
10. Into 120 grams of water at a temperature of 0° C. 150 grams of mercury at 80° C. are poured. What is the resulting temperature?
11. If 95 grams of a metal are heated to 100° C. and then placed in 114 grams of water at 7° C. the resulting temperature is 15° C. Find the specific heat of the metal? What metal is it?
12. A piece of iron, whose mass is 88.5 grams and temperature 90° C., is placed in 70 grams of water at 10° C. If the resulting temperature is 20° C., find the specific heat of iron.
13. A mass of zinc, weighing 5 kgs. and having a temperature of 80° C., was placed in a liquid and the resulting temperature was found to be 15° C. How much heat did the zinc impart to the liquid?
14. Find the resulting temperature on placing 75 grams of a substance having a specific heat of 0.8 and heated to 95° C. in 130 grams of a liquid at 10° C. whose specific heat is 0.6.
15. On mixing 1 kgm. of a substance having a specific heat of 0.85, at a temperature of 12° C., with 500 grams of a second substance at a temperature of 120° C., the resulting temperature is 45° C. What is the specific heat of the second substance?

CHAPTER XXIX

CHANGE OF STATE

273. Fusion. Let us take some pulverized ice at a temperature below the freezing point and apply heat to it. It gradually rises in temperature until it reaches 0° C., when it begins to melt. If the ice and the water formed from it are kept well stirred, no sensible change in temperature takes place until all the ice is melted. On the further application of heat, the temperature begins again to rise.

The change from the solid to the liquid state by means of heat is called *fusion* or *melting*, and the temperature at which fusion takes place is called the *melting point*.

The behaviour of water is typical of crystalline substances in general. Fusion takes place at a temperature which is constant for the same substance if the pressure remains invariable. Amorphous bodies, on the other hand, have no sharply defined melting points. When heated, they soften and pass through various stages of plasticity into more or less viscous liquids, the process being accompanied by a continuous rise in temperature. Paraffin wax, glass and wrought-iron are typical examples. By a suitable control of the temperature glass can be bent, drawn out, moulded or blown into various forms, and iron can be forged, rolled or welded.

274. Solidification. The temperature at which a substance solidifies, the pressure remaining constant, is the same as that at which it melts. For example, if water is gradually cooled, while it is kept agitated, it begins to take the solid form at 0° C., and it continues to give up heat without falling in temperature until the process of solidification is complete.

But it is interesting to note that a liquid which under ordinary conditions solidifies at a definite point may, if slowly and carefully cooled, be lowered several degrees below its normal temperature of solidification. The phenomenon is illustrated in the following experiment. Pour some pure water, boiled to free it from air bubbles, into a test-tube. Close the tube with a perforated stopper, through which a thermometer is inserted into the water. Place the tube in a freezing mixture of ice and salt. If the water is kept quiet it may be lowered to a temperature of -5° C. without freezing it, but the condition is unstable. If the water is agitated or crystals of ice are dropped in, it suddenly turns into ice and the temperature rises to 0° C.

275. Change of Volume in Fusion. Most substances suffer an increase in volume in passing from the solid to the liquid state, but some which are crystalline in structure, such as ice, bismuth, and antimony are exceptions to the rule.

The expansive force of ice in freezing is well known to all who live in cold climates. The earth is upheaved and rocks are disintegrated, while vessels and pipes which contain water are burst by the action of the frost.

Only from metals which expand on solidification can perfectly shaped castings be obtained. The reasons are obvious. Antimony is added to lead and tin to form type-metal because the alloy thus formed expands on solidifying and conforms completely and sharply with the outlines of the mould.

276. The Influence of Pressure on Melting Point. If a substance expands on melting, its melting point will be raised by pressure, while if it contracts its melting point will be lowered. We would expect this. Since extra pressure applied to a body which takes a larger volume on melting would tend to prevent it from expanding, it would be reasonable to suppose that a higher temperature would be necessary to bring about

the change; on the other hand, if the body contracts on melting, increased pressure would tend to assist the process of change, and a lower temperature should suffice.

An interesting experiment shows the effect of pressure on the melting point of ice. Take a block of ice and rest it on two supports, and encircle it with a fine wire from which hangs a heavy weight (Fig. 276). In a few hours the wire will cut its way through the ice, but the block will still be intact. Under the pressure of the wire the ice melts, but the water thus formed is below the normal freezing point. Hence it flows above the wire and freezes again as the pressure there is normal. The process of melting and freezing again under these conditions is called *regelation*.

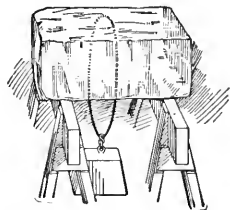

FIG. 276.—Regelation of ice.

277. Heat of Fusion. We have seen (in § 273) that during the process of melting a crystalline body like ice, no change in temperature takes place, although heat is being continuously applied to it. In earlier times, when heat was considered to be a kind of substance, it appeared that the heat applied became hidden in the body and it was called *latent heat*.

According to modern ideas, there is simply a transformation of energy. When a body in fusing ceases to rise in temperature, although heat is still being applied, the heat-energy is no longer occupied in increasing the average kinetic energy and to some extent the potential energy of its molecules, but is doing work in overcoming the cohesive forces which bind these molecules together in the body as a solid.

A definite quantity of heat, varying with the substance, is required to melt a definite mass of a solid. The amount of heat required to melt one gram of a substance without a change of temperature is called its *heat of fusion*. For

example, the heat of fusion of ice is 80 calories, which means that 80 calories of heat are required to melt one gram of ice.

278. Determination of the Heat of Fusion of Ice. The *method of mixture* (§ 272) may be used to determine the heat of fusion of ice. For example, if 100 grams of dry snow or finely broken ice are dropped into 500 grams of water at 90° C., and the mixture is rapidly stirred until all the ice is melted, it will be found that the resulting temperature is about 62° C.

Then the amount of heat lost by 500 grams of water in cooling from 90° C. to 62° C. = $500(90 - 62) = 14,000$ calories.

This heat melts the ice and then raises the temperature of the resulting water from 0° to 62° C. But to raise the resulting 100 grams of water from 0° to 62° C. requires $100 \times 62 = 6200$ calories.

Hence the heat required to melt the 100 grams of ice = $14,000 - 6200 = 7800$ calories, and the heat required to melt 1 gram of ice = 78 calories.

A general formula is obtained as follows:—

Let m = the mass of water (in grams),
 t_1 = its initial temperature,
 t_2 = its final temperature,
 m_1 = the mass of the ice (in grams),
 x = the heat of fusion.

Then heat lost by water in falling from t_1 to $t_2 = m(t_1 - t_2)$ cal.

Heat required to melt m_1 grams of ice = $m_1 x$ cal.

Heat required to raise m_1 grams of water from 0° to $t_2 = m_1 t_2$ cal.

But the heat lost by the water is used in melting the ice and raising the temperature of the resulting water from 0° to t_2 .

$$\text{Hence, } m(t_1 - t_2) = m_1 x + m_1 t_2,$$

$$\text{and } x = \frac{m(t_1 - t_2) - m_1 t_2}{m_1}.$$

279. Heat given out on Solidification. All the heat required to melt a certain mass of a substance without change

in temperature is given out again in the process of solidification. Thus, every gram of water, in freezing, sets free 80 calories of heat. The formation of ice tends to prevent extremes of temperature in our lake regions. Heat is given out in the process of freezing during the winter, and absorbed in melting the ice in spring and early summer.

280. Heat Absorbed in Solution; Freezing Mixtures.

Change of state through the action of a solvent is also associated with thermal changes. In cases of ordinary solution, as in dissolving sugar or salt in water, heat is absorbed. If a handful of salt is dropped into a beaker of water at the temperature of the room, and the mixture is stirred with a thermometer, the mercury will be seen to drop several degrees.

The result is much more marked if ice and salt are mixed together. Both become liquid and absorb heat in the transition. This is the principle applied in preparing freezing mixtures. The ordinary freezing mixture of ice and salt can be made to give a fall in temperature of about 22° C.

QUERY.—What is the heat absorbed from?

QUESTIONS AND PROBLEMS

1. Why is it impossible to weld together two pieces of cast-iron?
2. Water is sometimes placed in cellars to keep vegetables from freezing. Explain the action.
3. Why is a quantity of ice at 0° C. more effective as a cooling agent than an equal mass of water at the same temperature?
4. If two pieces of ice are pressed together under the surface of warm water they will be found to be frozen together on removing them from the water. Account for this.
5. If we pour just enough cold water on a mixture of ammoniac chloride and ammoniac nitrate to dissolve them, and stir the mixture with a small test-tube, into the bottom of which has been poured a little cold water, the water in the tube will be frozen. Explain.

[In the following problems take the heat of fusion of ice as 80 calories per gram.]

6. What quantity of heat is required to melt 35 grams of ice at 0° C.?

7. How much heat is given off by the freezing of 15 kgs. of water?
8. Find the resulting temperature when 40 grams of ice are dropped into 180 grams of water at 90°C .
9. How much ice must be placed in a pail containing 10 kgs. of drinking water at 20°C . to reduce the temperature to 10°C .?
10. What mass of water at 80°C . will just melt 80 grams of ice?
11. How much heat is required to change 23 grams of ice at -10°C . to water at 10°C .? (Specific heat of ice = 0.5.)
12. What mass of water at 75°C . will convert 120 grams of ice into water at 10°C .?
13. What mass of ice must be dissolved in a litre of water at 4°C . to reduce the temperature to 3°C .?
14. What is the specific heat of brass if a mass of 80 grams at a temperature of 100°C . melts 9 grams of ice?
15. Fifty grams of ice are placed in 520 grams of water at 19.8°C . and the temperature of the whole becomes 11.1°C . Find the heat of fusion of ice.

281. Vaporization. Transition from a liquid to a vapour is a familiar phenomenon. Water in a shallow dish exposed to a dry atmosphere gradually disappears as a vapour into the air. If heat is applied and the water is made to boil, the change takes place more rapidly. The process of converting a liquid into a vapour is called *vaporization*. The quiet vaporization taking place at all temperatures at the surface of a liquid is known as *evaporation*.

In *ebullition*, or *boiling*, the production of vapour takes place throughout the mass, and the process is accompanied by an agitation of the liquid, due to the formation of bubbles of vapour within the liquid and their movement upward to the surface.

282. Rate of Evaporation. The rate of evaporation depends on the nature of the liquid. A little ether placed on the palm of the hand disappears almost at once, while the hand remains wet with water for a considerable time. Some dense oils can scarcely be said to evaporate at all. Liquids which evaporate readily are said to be *volatile*.

Temperature also affects the rate of evaporation. Other conditions being the same, the rate of evaporation increases with the temperature. Clothes and wet roads dry more rapidly on a warm day than on a cold one, if the atmosphere is equally dry on the two days.

Further, the rate of evaporation is affected by the amount of vapour of the liquid in the surrounding space and also by the presence in this space of other gases.

283. Pressure of a Vapour. Let us consider the case of evaporation in an inclosed space. When a few drops of ether are introduced, by means of a medicine dropper with a curved stem, into the tube of a cistern barometer and allowed to rise to the surface of the mercury, evaporation begins at once, and the pressure exerted by the vapour formed depresses the mercury (Fig. 277). The mercury soon comes to rest at a height ab , which remains constant so long as the temperature is unchanged.

If the volume of the vapour is decreased by lowering the tube in the cistern, or increased by raising it, the difference in level ab will not be permanently altered. It is evident, therefore, that, under these conditions, the pressure of a vapour is independent of its volume, when the temperature is constant, provided some liquid is always present.

284. Molecular Explanation of Evaporation. According to the kinetic theory (§ 151) the molecules of a liquid are in rapid motion, and some of these arrive at the surface with sufficient velocities to escape from the attraction of the neighbouring molecules. These molecules constitute the vapour of the liquid. When the ether enters the tube, the



FIG. 277.—Pressure conditions of evaporation within an inclosed space.

closed space above the mercury at once begins to be filled with molecules moving about in straight lines. These bombard the walls of the tube and the surface of the liquid itself. Many of these molecules, as their number increases, come again within the range of attraction of the molecules at the surface and re-enter the liquid. Evaporation ceases when the number of the molecules entering the liquid in a given time equals the number which escape. When the tube is lowered and the vapour made to take less volume, the density is momentarily increased. The number of molecules now entering the liquid is greater than that leaving it. In other words, some of the vapour is being condensed to a liquid. The process ceases when the former pressure and density are restored.

When the volume of the vapour is increased by lifting the tube, the density and pressure are momentarily decreased, and the number of molecules escaping per second from the liquid becomes greater than the number entering it. Evaporation continues until the vapour density and pressure again reach the maximum. Equilibrium is very quickly restored.

285. Saturated Vapour. When a vapour has its maximum density for any given temperature it is said to be *saturated*, and the corresponding maximum pressure is called the *saturation pressure*. Whenever a saturated vapour is either cooled or compressed, condensation takes place. For saturation, some of the liquid must be present.

The temperature being constant, the saturation pressure varies with the volatility of the liquid. This may be shown by introducing other liquids—say alcohol or water—into barometer tubes, and noting the pressure as indicated by the depression of the mercury. At 20° C. the depression for alcohol is about 44 mm. and for water 17.5 mm.

286. Evaporation into Air. The amount of evaporation into a closed space is practically the same whether the space is filled with air or is a vacuum; but the presence of the air

materially retards the rate of evaporation. When the ether is introduced into the barometer tube, the mercury rapidly falls as far as it will go, but when ether is enclosed in a tube along with air over mercury, it will be several hours before equilibrium is restored. The depression in the end, however, will represent a vapour pressure the same as in the tube void of air.

It is obvious that there can be no limit to the amount of evaporation when a liquid is exposed in an open vessel. Water left in a basin in time disappears. But the presence of vapour in the layers of air immediately above the liquid arrests the process, and the action of the air currents in carrying away vapour-laden air hastens evaporation. Wet articles dry very rapidly on a windy day.

287. Ebullition—Boiling Point. When heat is applied to water (Fig. 278) it gradually rises in temperature until vapour is disengaged in bubbles from the mass of the liquid. No further increase in temperature takes place, however rapidly the process of boiling is maintained.

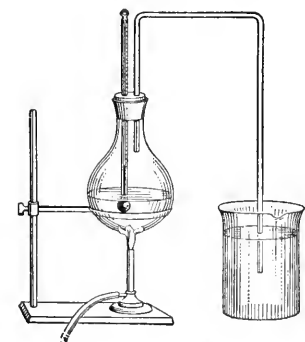

FIG. 279.—Boiling point of a liquid raised by means of pressure.

The temperature at which a liquid boils, or gives off bubbles of its own vapour, is called its *boiling point*.

288. Effect of Pressure on the Boiling Point. The boiling point varies with the pressure. If the pressure of the escaping steam is increased by leading the outlet-pipe to the bottom of a vessel of

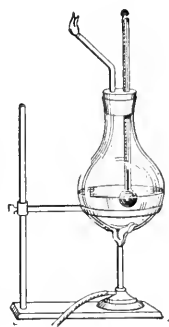

FIG. 278.—Determination of the boiling point of a liquid.

water as shown in Fig. 279, the temperature of the boiling water is increased. On the other hand, a decrease in pressure

is accompanied by a lowering of the temperature. This is shown by a familiar but striking experiment.

Half fill a flask with water and boil for a minute or two in order that the escaping steam may carry out the air. While the water is boiling remove the flame, and at the same instant close the flask with a stopper. Invert the flask and support

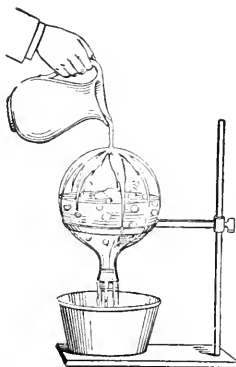

FIG. 280.—Boiling point of a liquid lowered by decrease of pressure.

it on a retort stand (Fig. 280), and pour cold water over the flask. The temperature of the water in the flask is below 100° C., but it boils vigorously. The action is explained as follows. The chilling of the flask condenses the vapour within and thus reduces the pressure on the surface of the water. The water, relieved of this pressure, boils at a lower temperature. If we discontinue the cooling and allow the vapour to accumulate and the pressure to increase, the boiling ceases. The process may be repeated several times. In fact, if care is taken in expelling the air at the beginning, the water may be made to boil even when the temperature is reduced to that of the room.

The reason why the boiling point depends upon the pressure is readily found. Bubbles of vapour begin to form in the liquid only when the pressure exerted by the vapour within the bubble balances the pressure on the surface of the liquid (Fig. 281). Were the pressure in the bubble less, the bubble would collapse. But the pressure of a vapour in contact with its liquid in an enclosed space varies with the temperature.

The temperature of the water in the flask is below 100° C., but it boils vigorously. The action is explained as follows. The chilling of the flask condenses the vapour within and thus reduces the pressure on the surface of the water. The water, relieved of this pressure, boils at a lower temperature. If we discontinue the cooling and allow the vapour to accumulate and the pressure to increase, the boiling ceases. The process may

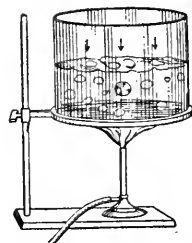

FIG. 281.—Balance between external pressure of the air and the pressure exerted by the vapour within a bubble.

Hence, a liquid

will be upon the point of boiling when its temperature has risen sufficiently high for the pressure of the saturated vapour of the liquid to be equal to the pressure sustained by the surface of the liquid. Therefore, when the pressure on the surface is high, the boiling point must be high, and *vice versa*. The

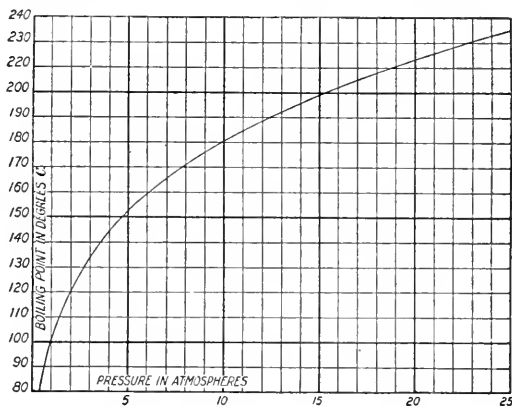

FIG. 282.—Curve showing the relation between the pressure and the boiling point of water.

accompanying diagram (Fig. 282) shows graphically the relation between the pressure and the boiling point of water, ranging from 1 to 25 atmospheres.

It is to be noted that the steam bubbles begin in the small air or gas bubbles present in the water, and when these are removed by prolonged boiling the liquid boils very irregularly (bumps). Geyser phenomena occur because of great hydrostatic pressure due to the water.

Since the boiling point is dependent on atmospheric pressure, a liquid in an open vessel will boil at a lower temperature as the elevation above the sea-level increases. This decrease is roughly 1° C. for an increase in elevation of 293 metres (= 961 feet). The boiling point of water at the summit of Mont Blanc (15,781 feet) is about 85° C., and at Quito (9520 feet), the highest city in the world, it is 90° C.

In such high altitudes the boiling point of water is below the temperature required for cooking many kinds of food, and artificial means of raising the temperature have to be resorted to, such as cooking in brine instead of pure water, or using closed vessels with safety devices to prevent explosions. Sometimes longer boiling is all that is required.*

In the case of liquids liable to burn, evaporation may be produced in "vacuum pans" in which boiling takes place under reduced pressure (and therefore lowered temperature). This arrangement is used, for example, in condensing milk and sugar syrups.

289. Heat of Vaporization. Whenever a given mass of a liquid changes into a vapour, a definite amount of heat is absorbed. Thus in the process of vaporization a certain amount of energy ceases to exist as heat, and (in a manner similar to fusion) becomes potential energy in the vapour. In accordance with the law of Conservation of Energy, all heat which thus disappears is recovered when the vapour condenses.

The amount of heat required to change one gram of any liquid into vapour without changing the temperature is called

the HEAT OF VAPORIZATION, or sometimes the latent heat of vaporization. For example, the heat of vaporization of water is 536 calories, by which we mean that when water is boiling under the standard atmospheric pressure (76 cm. of mercury) 536 calories of heat are required to vaporize one gram without change of temperature.

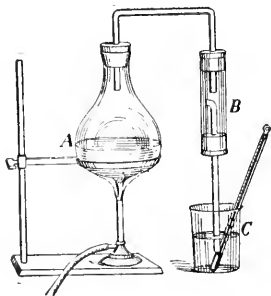

FIG. 283.—Determination of heat of vaporization of water. *A*, flask to contain water; *B*, trap to catch water condensed in the tube; *C*, vessel with known mass of water.

*Eggs can be boiled hard in an open vessel on Pike's Peak, 14,108 ft. high.

290. Determination of Heat of Vaporization. The heat of vaporization of water may be determined as follows:—By means of apparatus arranged as shown in Fig. 283 pass steam for a few minutes into a quantity of water in a vessel *C*. Take the weight and the temperature of the water before and after the steam is conveyed into it and find the increase in mass and temperature due to the condensation of the steam.

Suppose the mass of water in *C* at first to be 120 grams and the increase in mass due to condensation to be 5 grams; and suppose the initial and final temperatures of the water to be 10° C. and 35° C. respectively.

We can make our calculation as follows:—

Heat gained by the original 120 grams of water = $120(35 - 10) = 3000$ cal.

This heat comes from two sources,

- (a) The heat received from the condensation of 5 grams of steam at 100° C. to water at 100° C.
- (b) The heat received from the fall in temperature of 5 grams of water from 100° C. to 35° C. = $5(100 - 35) = 325$ cal.

Hence, the heat set free by the condensation of 5 grams of steam = $3000 - 325 = 2675$ cal.

And the heat set free in the condensation of 1 gram of steam = $2675 \div 5 = 535$ cal.

QUESTIONS AND PROBLEMS

1. The singing of a tea kettle just before boiling is said to be due to the collapse of the first bubbles formed in their upward motion through the water. Explain the cause of the collapse of these bubbles.
2. When water is boiling in a deep vessel the bubbles of vapour are observed to increase in size as they approach the surface of the water. Give a reason for this.
3. Why does not a mass of liquid air in an open vessel immediately change into gas when brought into a room at the ordinary temperature?
4. Why is it necessary to take into account the pressure of the air in fixing the boiling point of a thermometer?

[In the following problems take the heat of vaporization of water as 536 calories per gram.]

5. How much heat will be required to vaporize 37 grams of water?
6. How many calories of heat are set free in the condensation of 340 grams of steam at 100° C. into water at 100° C.?
7. How much heat is required to raise 45 grams of water from 15° C. to the boiling point and convert it into steam?
8. How much heat is given up in the change of 365 grams of steam at 100° to water at 4° C.?
9. What is the resulting temperature when 45 grams of steam at 100° C. are passed into 600 grams of ice-cold water?
10. How many grams of steam at 100° C. will be required to raise the temperature of 300 grams of water from 20° C. to 40° C.?
11. How many grams of steam at 100° C. will just melt 25 grams of ice at 0° C.?
12. How much heat is necessary to change 30 grams of ice at -15° C. to steam at 100° C.? (Specific heat of ice = 0.5.)
13. An iron radiator whose mass is 55 kgms. and temperature 100° is shut off when it contains 100 grams of steam at a temperature of 100° C. How much heat is imparted to the room by the condensation of the steam and the cooling of the water and the radiator to a temperature of 40° C.? (Specific heat of iron = 0.113.)
14. If 34.7 grams of steam at 100° C. are conveyed into 500 grams of water at 20° C., the resulting temperature is 60° C. Find the heat of vaporization of water.

291. Cold by Evaporation. In order to change a liquid into vapour, heat is always required. Water placed over a flame is turned into vapour, the heat required being supplied by the flame. If a little ether is poured on the palm of the hand it vaporizes at once. Here the heat to produce vaporization is supplied by the hand, which therefore feels cold. For a similar reason wet garments are cold, especially if drying rapidly on a windy day.

But it is sometimes possible to produce vaporization without supplying heat from an outside source. In this case the heat comes from the liquid itself, which must therefore fall in temperature. Indeed, it is possible, by producing evaporation, to lower the temperature of water so much that the water will actually freeze. This is well shown in Leslie's experiment. A small quantity of cold water in a watch glass is enclosed in the receiver of an air-pump over a dish of strong sulphuric acid (Fig. 284). The air is then exhausted from the receiver. When the pressure is reduced sufficiently, the water begins to boil, and as the vapour is removed from the receiver, partly by being carried off with the air by the pump, and partly by absorption into the sulphuric acid, the process continues until the water is frozen.

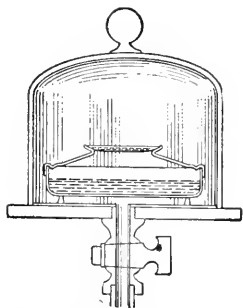

FIG. 284.—Leslie's experiment; freezing water by its own evaporation.

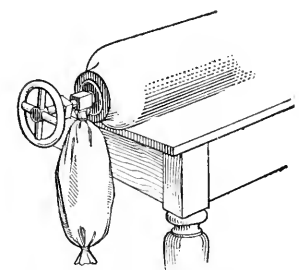

FIG. 285.—Freezing of carbon-dioxide by evaporation from the liquid form.

Similar results are shown in a more striking manner by the freezing of carbon-dioxide by evaporation from the liquid form. If the liquefied gas (contained in a strong steel cylinder) is allowed to escape into a bag attached to the outlet pipe of the cylinder (Fig. 285), it will be frozen into snowy crystals by the intense cold produced in the rapid evaporation of the liquid.

292. Practical Applications of Cooling by Vaporization. Vaporization is our chief source of "artificial cold." The applications are numerous and varied. Fever patients are

sponged with volatile liquids to reduce temperature. Ether sprays are used for freezing material for microscopic sections. Evaporation is also utilized in making artificial ice, in cooling cold-storage buildings, and in freezing shifting quicksands for engineering purposes. The liquid most commonly used for

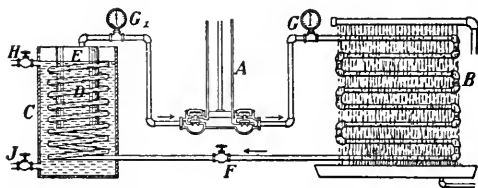

FIG. 286.—Ice-making machine. *G*, high-pressure gauge; *G₁*, low-pressure gauge; *A*, pump for exhausting low-pressure coils and condensing gas; *B*, condenser coils cooled by running water from a pipe placed above them; *F*, regulating valve; *D*, low-pressure coils; *C*, tank containing brine; *E*, can containing water to be frozen.

the latter purposes is ammonia liquefied by pressure. This is convenient for the purpose because the gas liquefies at ordinary temperature under relatively moderate pressure (about 10 atmospheres), and it absorbs a great amount of heat in evaporation. Fig. 286 shows the essential parts of an ice-making machine. The ammonia gas is forced by the pump into the condenser coils and liquefied there by pressure, the heat given out in condensation being carried off by the water circulating on the outside of the coils. The liquid ammonia escapes slowly through the regulating valve into the low-pressure coils, where it evaporates, producing intense cold. In consequence the brine which surrounds the coils is cooled below the freezing point of water, and the water to be frozen, placed in cans submerged in it, is converted into ice.

It will be observed that the process is continuous. The pump which forces the ammonia into the condenser coils receives its supply of gas from the low-pressure coils. The same ammonia is thus used over and over again.

In some cold-storage plants, the brine cooled as described above, is made by a force-pump to circulate in coils distributed at suitable centres throughout the building. (Fig. 287).

The temperature of the air in the cold-storage rooms is thus reduced in hot weather by cold coils very much as it may be raised in winter

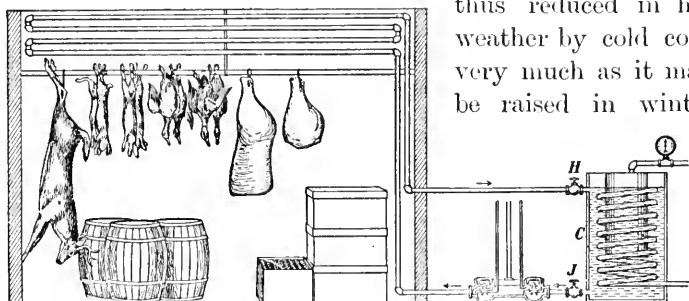

Fig. 287.—Cold-storage plant.

by similar coils containing hot water or steam.

293. Condensation—Critical Temperature. We have seen that a vapour in a condition of saturation is condensed if its temperature is lowered or its pressure is increased. At this point an interesting question arises. Can an unsaturated vapour at any given condition of temperature be reduced to a liquid by increase of pressure alone? The question has been answered experimentally. It has been found that for every vapour there is a temperature above which pressure alone, however great, is ineffectual in producing condensation. This temperature is known as the *critical temperature*, and the pressure necessary to produce condensation at this temperature is called the *critical pressure*. For example, Andrews,* to whom we owe an exhaustive study of the subject, found that to reduce carbon-dioxide to a liquid the temperature must be lowered to at least 30.92° C., and that above that temperature no amount of pressure would convert it into liquid form.

The critical temperature of water, alcohol, ammonia, and carbon-dioxide are above the average temperature of the air, while those of the gases oxygen, hydrogen and air are much below it. The critical temperature of water is 365° C. and of air -140° C.

*Thomas Andrews (1813-1885) Professor of Chemistry, Queen's College, Belfast, 1845-1879.

Below the critical temperature a further lowering of the temperature lessens the pressure necessary to condensation. For example, a pressure of 73 atmospheres is necessary to condense carbon-dioxide at the critical temperature, but 60 atmospheres is sufficient at a temperature of 21.5° and 40 atmospheres at a temperature of 13.1° . Again, a pressure of 200 atmospheres is necessary to condense steam at the critical temperature (365° C.); at 100° C. it condenses under a pressure of one atmosphere.

294. Liquefaction of Air. The apparatus generally used to condense air into a liquid depends on the fact that when a gas is

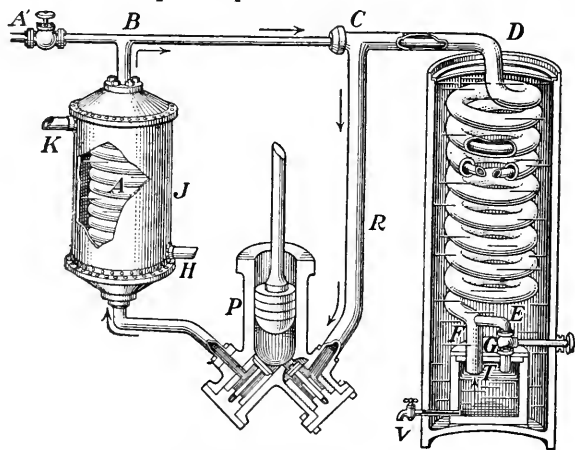

FIG. 288.—Essential parts of a liquid-air machine.

compressed its temperature rises, and when it expands, thus doing work, its temperature falls. In Fig. 288 is shown the essential parts of a liquid-air machine.

To one side of the pump *P* is joined one end of a coil of pipe *A* which is within *J*, a jacket through which cold water is always running, entering at *K* and leaving at *H*. The long coil to the right is double. A small pipe runs within a larger one. In the figure the second and third turns (from the top) of the larger pipe are shown cut away, exposing the smaller pipe within. The smaller pipe enters the larger one at *C*, passes on to *D* and down to *F*. Here it emerges and goes over to *E* where its end may be closed by a valve *G*.

The action is as follows : The pump P draws in air from the large pipe R , and forces it, at a pressure of about 200 atmospheres, through the coil A , where it is cooled to the temperature of the water. The air passes on to B and then to C , and going through the inner coil it descends to F and then to E . Through the slightly opened valve G it expands into the vessel T being thereby cooled. From here it enters the end of the larger pipe of the coil and ascends, it reaches D and then C , whence it goes down to enter the pump again.

Now the air on expanding into T was cooled, and hence as it ascends through the outer coil it cools the air in the inner coil. As this process is continued the air in the inner coil gets colder and colder until at last it becomes liquid and collects in T' at a temperature of about -182° C. From this it is drawn off by the tap V .

To make 1 cu. inch of liquid about one-half a cu. foot of air is required, and when the liquefaction has begun fresh air must be supplied. It is introduced at A' from an auxiliary compressor at a pressure of about 200 atmospheres.

295. Condensation of Water-Vapour of the Air—Dew-point. Evaporation is constantly taking place from water at the surface of the earth, and consequently the atmosphere always contains more or less water-vapour. This vapour will be on the point of condensation when its pressure approaches the saturation pressure. Now, since this pressure varies with the temperature, the nearness to saturation at any given time will depend on the temperature as well as upon the amount of vapour present per unit volume. Accordingly, the amount of vapour which a given space will contain rises rapidly with the temperature. Thus a given space will hold more than three times as much vapour at 30° C. as at 10° C.

If the amount of vapour in a given space remains constant and the temperature is lowered gradually, a temperature will at length be reached *at which condensation will begin to take place*. This temperature is called the DEW-POINT.

The dew-point may be determined experimentally by Regnault's method as follows. In the apparatus shown in Fig. 289 the lower portions of the glass tubes are covered with polished metal, and through the corks thermometers and

connecting tubes are inserted. Pour ether into the vessel fitted with the atomizer bulb and force air through it. This agitation of the ether makes it evaporate rapidly and thus the temperature is lowered. Note the temperature at which the polished surface surrounding the ether becomes dimmed with dew. Cease forcing the air and again note the temperature at which the moisture disappears. The mean of the two temperatures is taken as the dew-point.

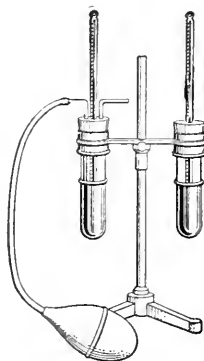

FIG. 289.—Determination of the dew-point.

The second vessel enables the observer, by comparison, to determine more readily the exact moment when condensation begins. The thermometer in this vessel gives the temperature of the air in the room at the time of the experiment.

296. Relative Humidity. The term humidity, or RELATIVE HUMIDITY, is used to denote *the ratio of the mass of water-vapour present in the air, to the mass required for saturation at the same temperature.* The air is said to be very dry when the ratio is low, and damp when it is high. These terms, it should be observed, have reference, not to the absolute amount of vapour present, but to the relative degree of saturation at the given temperature. At the present moment the air outside may be raw and damp, but after having been forced by a fan over a series of steam-heated coils, it appears in the laboratory comparatively dry. It is not to be inferred that the air has lost any of its vapour; rather that in being heated it has acquired the capacity of taking up more, because the saturation pressure has been raised by the increase of temperature.

The relative humidity is usually expressed as a percentage of the maximum amount of vapour possible at the temperature.

For example, when a cubic centimetre of air contains but one-half of the amount of water-vapour necessary for saturation, its humidity is said to be 50 per cent.

This percentage is most accurately determined by a calculation from the dew-point. Take a particular example. Suppose the dew-point to be 12° C. when the temperature of the air in the room is 20° C. From a table of constants it is learned that saturated water vapour at 12° C. contains 0.0000106 grams per cubic centimetre, and at 20 degrees, 0.0000172 grams per cubic centimetre. Then since one cubic centimetre actually contains at 20° C. just the amount of vapour necessary for saturation at 12° C. the degree of saturation is $\frac{1}{7} \frac{6}{2}$ or 61.6 per cent.

The humidity may also be determined by the Wet-and-Dry-Bulb Hygrometer. The instrument consists of two similar thermometers mounted on the same stand (Fig. 290). The bulb of one of the thermometers is covered with muslin kept moist by a wick immersed in a vessel of water. Evaporation from the wet bulb lowers its temperature, and since the ratio of evaporation varies with the dryness of the atmosphere, it is evident that the differences in the readings of the thermometers may be used as an indirect means of estimating the relative humidity of the atmosphere. The percentages are given in tables prepared by comparison with results determined from dew-point calculations.

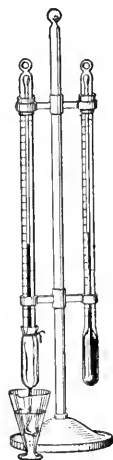

FIG. 290.—Wet-and-dry bulb hygrometer.

297. Relation of Humidity to Health. Humidity has an important relation to health and comfort. When the relative humidity is high, a hot day becomes oppressive because the dampness of the atmosphere interferes with free evaporation from the body. On the other hand, when the air becomes too dry the amount of this evaporation is too great. This condition very frequently prevails in winter in houses artificially

heated. Under normal conditions the relative humidity should be from 50 to 60 per cent.

298. Fog and Clouds. If the air is chilled below the temperature for saturation, vapour condenses about dust particles suspended in the air. If this condensation takes place in the strata of air immediately above the surface of the earth, we have a *fog*; if in a higher region, a *cloud*. The cooling necessary for fog formation is due to the chilling effects of cold masses at the surface of the earth; in the upper region, a cloud is formed when a stratum of warm moist air has its temperature lowered by its own expansion under reduced pressure. It would appear from recent investigations that under all conditions dust particles are necessary as nuclei for the formation of cloud globules.

299. Dew and Frost. On a warm summer day drops of water collect on the surface of a pitcher containing ice-water, because the air in immediate contact with it is chilled below the dew-point. This action is typical of what goes on on a large scale in the deposition of *dew*. After sunset, especially when the sky is clear, small bodies at the earth's surface, such as stones, blades of grass, leaves, cobwebs, and the like, cool more rapidly than the surrounding air. If their temperature falls below the temperature of saturation, dew is deposited on them from the condensation of the vapour in the films of air which envelope them. If the dew-point is below the freezing-point the moisture is deposited as frost.

300. Rain, Snow and Hail. The cloud globules gravitate slowly towards the earth. If they meet with conditions favourable to vaporization they change to vapour again, but if with conditions favourable to condensation they increase in size, unite, and fall as rain.

When the condensation in the upper air takes place at a temperature below the freezing-point, the moisture crystallizes

in *snow-flakes*. At low temperatures, also, vapour becomes transformed into ice pellets and descends as *hail*. The hail-stones usually contain a core of closely packed snow crystals, but the exact conditions under which they are formed are not yet fully understood.

301. Distillation. Distillation is a process of vaporization and condensation, maintained usually for the purpose of freeing a liquid from dissolved

solids, or for separating the constituents of a mixture of liquids. Fig. 291 shows a simple form of distillation apparatus. The liquid to be distilled is evaporated in the flask

A, and the product of the condensation of the vapour is collected in the receiver *B*. The pipe connecting *A* and *B* is kept cold by cold water made to circulate in the jacket which surrounds it.

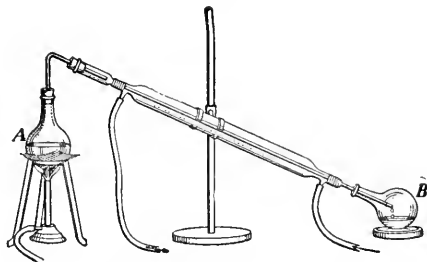

FIG. 291.—Distillation apparatus.

The separation of liquids by distillation depends on the principle that different liquids have different boiling points, and consequently are vaporized and can be collected in a regular order. For example, when crude petroleum is heated in a still the dissolved gaseous hydrocarbons are driven off first; then follow the lighter oils, naphtha, gasoline and benzine; in turn come the kerosene or burning oils; and later the heavier gas and fuel oils, etc. To obtain a quantity of any one constituent of a mixture in a relatively pure state, it is necessary to resort to *fractional distillation*. The fraction of the distillate which is known to contain most of the liquid desired is redistilled, and a fraction of the distillate again taken for further distillation, and so on.

QUESTIONS AND PROBLEMS

1. Why does sprinkling the floor have a cooling effect on the air of the room?
2. As exhaustion of air proceeds, a cloud is frequently seen in the receiver of an air-pump. Explain.
3. Under what conditions will "fanning" cool the face?
4. Why can one "see his breath" on a cold day?
5. In eastern countries and at high elevations water is poured into porous earthenware jars and placed in a draught of air to cool. Explain the cause of cooling.
6. Dew does not usually form on a pitcher of ice water standing in a room on a cold winter day. Explain.
7. Why does a morning fog frequently disappear with increased strength of the sun's rays?

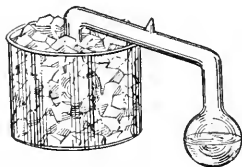

FIG. 292.—Cryophorus.

8. A tube having a bulb at each end has one of its bulbs filled with water, the remaining space containing nothing but water vapour. The empty bulb is surrounded by a freezing mixture (Fig. 292), and after a time it is found that the water in the other bulb is frozen. Explain. (Such a tube is called a *cryophorus*, which means *frost-carrier*.)

CHAPTER XXX

HEAT AND MECHANICAL MOTION

302. Mechanical Equivalent of Heat. We have referred (§ 241) to the fact that during the first half of the nineteenth



JAMES PRESCOTT JOULE (1818-1889). Lived near Manchester all his life. Experimented on the mechanical equivalent of heat for forty years.

century the kinetic theory of heat, advocated by Count Rumford and Sir Humphry Davy, gradually superseded the old materialistic conception. The modern theory was regarded as established when Joule, about the middle of the century, demonstrated that for every unit of mechanical energy which disappears in the transformation of mechanical motion into heat a definite and constant quantity of heat is developed. The value of the heat unit expressed in units of mechanical energy is called

the *mechanical equivalent* of heat.

303. Determination of the Mechanical Equivalent of Heat.

The essential features of Joule's apparatus for determining the mechanical equivalent of heat are illustrated in Fig. 293. A paddle-wheel was made to revolve in a vessel of water by a falling weight connected with it by pulleys and cords. Joule measured the heat produced by the motion of the paddle and the corresponding amount of work done by the descending weight. He calculated

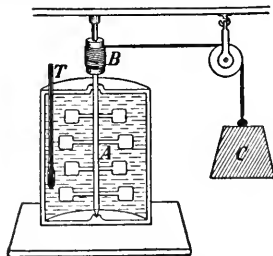

FIG. 293.—Principle of Joule's apparatus for determining the mechanical equivalent of heat.

that one B.T.U. of heat was equivalent to 772 foot-pounds of

mechanical energy. Later investigations by Rowland and others placed the constant at 778 foot-pounds for one B.T.U. of heat, which is equivalent to 4.187 joules (41,870,000 ergs) or 427 gram-metres of work for one calorie of heat.

304. Steam-Engine. Mechanical motion arrested by friction or percussion becomes transformed into heat energy. On the other hand, heat is one of our chief sources of mechanical motion. In fact, it is commonly said that modern industrial development, had its beginning in the invention of the steam-engine. The development of the engine as a working machine is due to James Watt, a Scottish instrument-maker, who constructed the first engine in 1768.

The essential working part of the ordinary type of steam-engine is a cylinder in which a piston is made to move backwards and forwards by the pressure

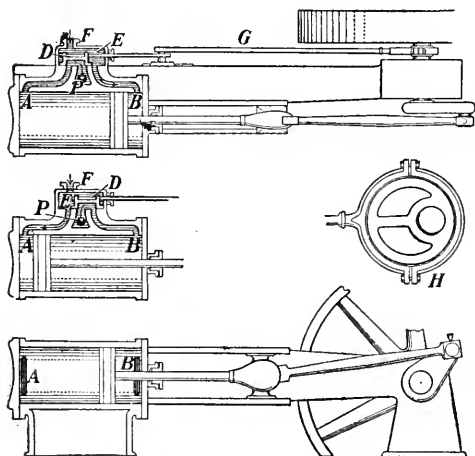

FIG. 294.—Steam engine. *A* and *B*, ports; *D*, slide valve; *E*, steam chest; *F*, pipe to boiler; *G*, eccentric rod; *H*, eccentric.

of steam applied alternately to its two faces (Fig. 294). The steam from the boiler is conveyed by a pipe *F* into a valve-chamber, or steam-chest, *E*. From the steam-chest the steam is admitted to the cylinder by openings called ports, *A* and *B*, at the ends of the cylinder. The exhaust steam escapes from the cylinder by the same ports. The admission of the steam to the cylinder, and its escape after it has performed its work, is controlled by the operation

of a valve *D*. This valve is so adjusted that when the port *A* is connected with the steam-chest, *B* is connected with an exhaust pipe *P*, leading to the open air or to a condenser; and when *B* is connected with the cylinder, *A* is connected with the exhaust pipe. The upper figure shows the steam entering at *A* and escaping at *B*. The piston, therefore, is being forced to the right, while the valve *D* is being pushed in the opposite direction by the motion of the

eccentric rod *G*. When the piston reaches the end of the stroke, the valve has moved to the position shown in the middle figure. Steam is now entering at *B* and escaping at *A*, and the piston is being forced to the left. In the meantime the valve is being moved to the original position as shown in the upper figure. A to-and-fro motion of the piston is thus kept up. This motion is transformed into a rotary motion in the shaft by the crank mechanism. The balance-wheels serve to give steadiness to the motion and to carry the engine over the "dead centres" at the ends of the strokes.

305. High and Low Pressure Engines. In the common "high pressure" engine, the steam escapes from the cylinder directly into the air. In the low pressure or condensing engine the exhaust is led into a chamber (Fig. 295), where it is condensed by jets of cold water. The water is removed by an "air-pump."

Since a more or less perfect vacuum is maintained in the condensing chamber of a low pressure engine, it will work under a given load at a lower steam pressure than the high pressure engine, because its piston does not encounter the opposing force of the atmospheric pressure.



FIG. 295.—Condenser of "low pressure" steam-engine.

306. The Compound Engine. When the pressure maintained in a boiler is high the steam escapes from the cylinder of an engine with energy capable of further work. The purpose of the compound engine is to utilize this energy latent in exhaust steam. In this type, two, three or even four cylinders with pistons connected with a common shaft are so arranged that the steam which passes out of the first cylinder enters the next, which is of wider diameter, and so on until it finally escapes into a condensing chamber connected with the last cylinder.

The compound engine is used mainly in large power plants and for marine purposes, when economy in fuel consumption is a first consideration.

307. Turbine Engine. Lately a new type of engine known as the steam turbine has been developed. In it a drum attached to the main shaft is made to revolve by the impact of steam directed by nozzles against blades attached to its outer surfaces as shown (Fig. 296).

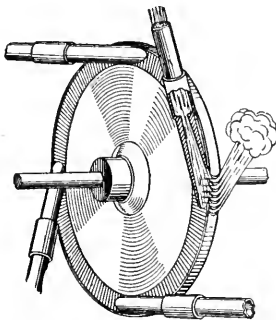

FIG. 296.—Action of steam on the blades of the drum in a turbine engine.

In another type of turbine, nozzles and blades are so adjusted that the steam after striking the first series of blades is reflected by a similar series of stationary blades against a second set of moving blades, and so on until the full working force of the steam is exhausted. (Fig. 297.)

So far the turbine engines have been used mainly for marine purposes and in some large electric power plants. The *Carmania*, which came out in December, 1905, was the first Atlantic liner to be propelled by steam turbines. The first vessel in our inland waters to be fitted with turbine engines was the *Turbinia*, plying between Toronto and Hamilton. The turbine engine

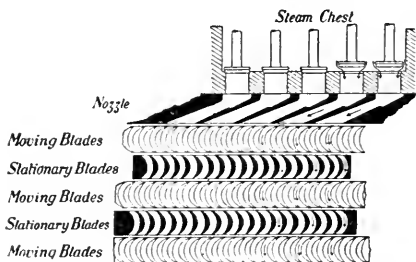

FIG. 297.—Reflection of steam from moving to stationary blades in steam turbine.

takes up less room than the ordinary form of reciprocating engine, and runs with much less vibration.

308. Gas Engines. Gas engines are coming into very general use as a convenient power for launches, automobiles, and power plants of moderate capacity.

In this form of heat engine, the fuel is burnt in the cylinder of the engine itself, and the piston is driven forward by the expansion of the heated gaseous products of the combustion. The fuel most commonly used is fuel-gas, or gasoline vapour, mixed with a sufficient quantity of air to form an explosive mixture.

A charge of the combustible mixture is drawn into the cylinder through an inlet valve during the forward motion of the piston, and compressed into about one-third the space by the return stroke. At a properly timed instant, the compressed charge is ignited by an electric spark at the points of a spark-plug, connected with an induction coil and battery, and the piston is forced forward by the expansion of the inclosed gas. On the backward motion of the piston an exhaust valve is opened, and the burnt gases escape from the cylinder. At the end of this stroke the engine is again on the point of taking in a new charge of fuel. It will be noted that the piston receives an impulse at the end of every fourth single stroke. The engine is accordingly described as a *four-stroke*, or *four-cycle* engine.

The momentum given the balance-wheel at each explosion serves to maintain the motion until the piston receives the next impulse. To cause the pressure to be more continuous in high-speed engines, two or more cylinders have frequently their pistons connected to a common shaft. The action of the four-stroke engine may be understood by referring to the accompanying diagrams of a four-cylinder, four-stroke engine.

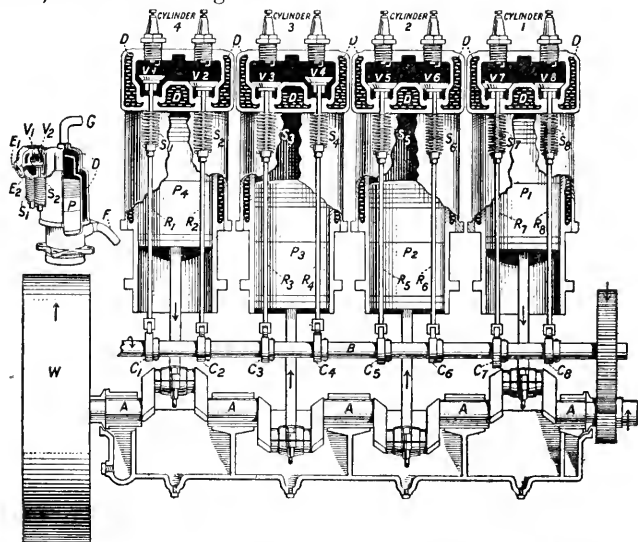

FIG. 298.—The working parts of a modern four-cylinder automobile or launch engine. *A*, main shaft; *W*, balance-wheel connected to main shaft; *P*₁, *P*₂, *P*₃, *P*₄, pistons; *V*₁, *V*₂, *V*₃, *V*₄, *V*₅, *V*₆, *V*₇, *V*₈, inlet valves; *V*₂, *V*₄, *V*₆, *V*₈, exhaust valves; *R*₁, *R*₂, etc., valve stems; *S*₁, *S*₂, etc., springs by which valves are closed; *B*, cam-shaft for operating valves, run by gears from main shaft; *C*₁, *C*₂, etc., cams for lifting valves; *D*, space to contain circulating water for cooling cylinder. The small diagram in the upper left-hand corner shows the connection between the valve-chamber and cylinder. *E*₁, inlet port; *E*₂, exhaust port; *F*, pipe by which cooling water enters; *G*, outlet for water. Two spark plugs are shown inserted at the top of each cylinder. One is connected with a battery system of ignition, the other with a magneto or dynamo. The electrical connections are so made that either may be used at will.

The balance wheel and pistons are moving in the directions of the arrows. A charge is being drawn into cylinder No. 4 through the inlet valve *V*₁, raised for the purpose by the pressure of the cam *C*₁ on the valve stem *R*₁. The charge which has been drawn in during the previous single stroke is being compressed in cylinder No. 2. The piston *P*₁ is being forced down by the expansion of the gases which have just been ignited in cylinder No. 1. The burnt gases from the previous explosion are escaping from cylinder No. 3 through the exhaust valve *V*₄, raised by the action of the cam *C*₄.

During the next single stroke, No. 3 will be drawing in a charge, No. 4 will be compressing, No. 2 will be exploding, and No. 1 will be exhausting; and so on for succeeding strokes.

EXERCISE.—Trace the action in any one cylinder for four successive single strokes.

The *two-stroke* (or *two-cycle*) engine differs from the four-stroke, in that the piston receives an impulse at the end of every second single stroke. This is accomplished as follows:—

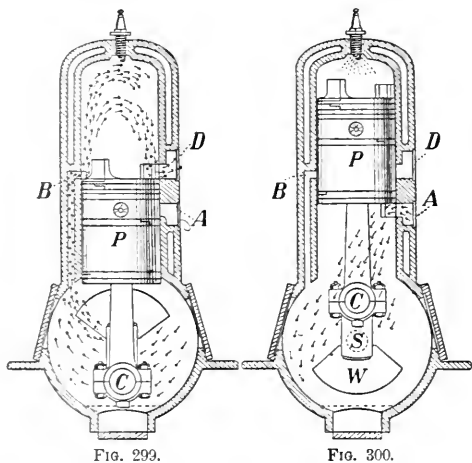

Working parts of a two-stroke gas engine. *P*, piston; *S*, main shaft; *C*, crank pin; *A*, inlet port to crank chamber; *B*, inlet port to cylinder; *D*, exhaust port; *W*, counterpoise weight.

through the port *A* (Fig. 300). The charge in the cylinder is ignited and the piston is forced forward in the second half-stroke giving an impulse to the fly-wheel, and compressing the new charge in the crank chamber. The action then goes on as before.

309. Efficiency of Heat Engines. All heat engines are wasteful of energy. The best types of compound condensing steam engines transform only about 16 per cent. of the heat of combustion into useful work, while the ordinary high-pressure steam engine in every-day use utilizes not more than 5 per cent. of the energy latent in the fuel.

The best steam turbines equal in efficiency the most economical forms of reciprocating engines.

The efficiency of the gas engine is much higher than that of the steam engine. Under good working conditions it will transform as high as 25 per cent. of heat energy into mechanical energy.

PROBLEMS

1. The average pressure on the piston of a steam engine is 60 lbs. per sq. inch. If the area of the piston is 50 sq. in. and the length of the stroke 10 in., find (a) the work done in one stroke by the piston; (b) how much heat, measured by B. T. U., was lost by the steam in moving the piston.

2. The coal used in the furnace of a steam pumping-engine furnishes on an average 7000 calories of heat per gram. How many litres of water can be raised to a height of 20 metres by the consumption of 500 kg. of coal, if the efficiency of the engine is 5 per cent.?

3. Supposing that all the energy of onward motion possessed by a bullet, whose mass is 20 grams and velocity 1000 metres per sec., is transformed into heat when it strikes the target, find in calories the amount of heat developed.

4. A train whose mass is 1000 tons is stopped by the friction of brakes. If the train was moving at a rate of 30 miles per hour when the brakes were applied, how much heat was developed?

5. How much coal per hour is used in the furnaces of a steamer when the screw exerts a pushing force of 1000 kgms. and drives the vessel at a rate of 20 km. per hour if the efficiency of the engine is 10 per cent., and the coal used gives on the average 6000 calories of heat per gram.?

6. A locomotive whose efficiency is 7 per cent. is developing on the average 400 horse power. Find its fuel consumption per hour if the coal furnishes 14,000 B.T.U.'s of heat per pound.

CHAPTER XXXI

TRANSFERENCE OF HEAT

310. Conduction of Heat. The handle of a silver spoon becomes warmed when the bowl is allowed to stand in a cup of hot liquid; the uncovered end of a glass stirrer, under similar conditions, remains practically unchanged in temperature. Heat creeps along an iron poker when one end is thrust into the fire; while a wooden rod conveys no heat to the hand.

The transference of heat from hotter to colder parts of the same body, or from a hot body to a colder one in contact with it, is called *conduction*, when the transmission takes place, as in these instances, without any perceptible motion of the parts of the bodies concerned.

311. Conducting Powers of Solids. The above examples show clearly that solids differ widely in their power to conduct heat. The tendencies manifest in silver and iron are typical of the metals; as compared with non-metals, they are good conductors. Organic fibres, such as wool, silk, wood, and the like, are poor conductors.

The metals, however, differ widely among themselves in conductivity. This may be shown roughly as follows:—

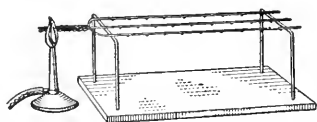

FIG. 301.—Difference in conductivity of metals.

Twist two or more similar wires of different metals—say copper, iron, German silver—together at the ends and mount them as shown in Fig. 301. By means of drops of wax attach shot or bicycle balls or small nails at equal intervals along the wires. Heat the twisted ends. The progress of the heat along the wires will be indicated by the melting of the wax and the dropping of the balls. When the line of separation between the melted and unmelted drops of wax ceases to move along the wire it will be found that the copper has melted wax at the greatest distance from the source of heat, the iron comes next in

order, and the German silver last. If the wax were distributed uniformly, and wires heated equally at their ends the conductivities of the wires would be approximately proportional to the squares of these distances.

The following table gives the relative conductivities of some of the more commonly used metals referred to copper as 100.

RELATIVE CONDUCTIVITIES OF METALS

Copper.....	100	Iron.....	23	Platinum.....	12
Aluminium...	47	Lead.....	11	Silver.....	133
Brass.....	32	Magnesium...	51	Tin.....	21
Gold.....	71	Mercury.....	2.4	Zinc.....	42

312. Conduction in Liquids. If we except mercury and molten metals, liquids are poor conductors of heat. Take water for example. We may boil the upper layers of water held in a test-tube over a lamp (Fig. 302) without perceptibly heating the water at the bottom of the tube.

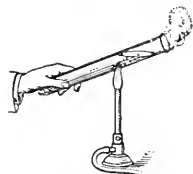

FIG. 302.—Water is a poor conductor of heat.

The poor conductivity of water is also strikingly shown in the following experiment.

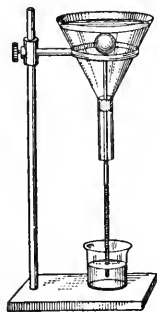

FIG. 303.—Illustration of the non-conductivity of water.

Pass the stem of a Galileo air-thermometer (§ 255) through a perforated cork inserted into a funnel as shown in Fig. 303. Then cover the bulb of the thermometer to a depth of about $\frac{1}{2}$ cm. with water. Now pour a spoonful of ether on the surface of the water and set fire to it. The index of the thermometer shows that little, if any, heat is transmitted by the water to the bulb from the flame

at the surface.

313. Conduction in Gases. Gases are extremely poor conductors of heat. The conductivity of air is estimated to be only about 0.000,049 of that of copper. Many substances, such as wool, fur, down, etc., owe their poor conductivity to the fact that they are porous and contain in their interstices air in a finely divided state. If these substances are compressed they become better conductors.

Light, freshly fallen snow encloses within it large quantities of air, and consequently forms a warm blanket for the earth, protecting the roots of plants from intense frost.

Heat is conducted with the greatest difficulty through a vacuum. For holding liquid air Dewar introduced glass flasks with hollow walls from which the air has been removed. The inner surfaces of the walls are silvered to prevent radiation (§ 570). The familiar "Thermos" bottle is constructed in this way. When contained in such a vessel a hot substance will remain hot and a cold one cold for a long time.

314. Practical Significance of Conduction in Bodies. The usefulness of a substance is frequently determined by its relation to heat conduction. The materials used to convey heat, such as those from which furnaces, steam boilers, utensils for cooking, etc., are constructed must, of course, be good conductors.

On the other hand, substances used to insulate heat, to shut it in or keep it out, should be non-conductors. A house with double walls is warm in winter and cool in summer. Wool and fur are utilized for winter clothing because they refuse to transmit the heat of the body.

In this connection the action of metallic gauze in conducting heat should be noted. Depress upon the flame of a Bunsen Burner a piece of fine wire gauze. The flame spreads out under the gauze but does not pass through it (*B*, Fig. 304). Again, turn off the gas and hold the gauze about half-an-inch above the burner and apply a lighted match above the gauze (*A*, Fig. 304). The gas burns above the gauze. The explanation is that the metal of the gauze conducts away the heat so rapidly that the gas on the side of the gauze opposite the flame is never raised to a temperature sufficiently high to light it. This principle is applied in the construction of the Davy safety lamp for miners. A jacket of wire gauze encloses the lamp, and prevents the heat of the flame from igniting the combustible gas on the outside. (Fig. 305.)

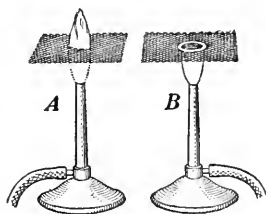

FIG. 304.—Action of metallic gauze on a gas-flame.

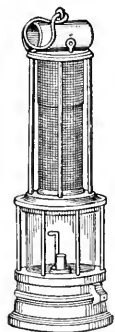

FIG. 305.—Davy safety lamp.

315. Conductivity and Sensitiveness to Temperature. We have already referred to the fact that our sensations do not give us reliable reports of the relative temperatures of bodies.

This is in part due to the disturbing effects of conduction. To take an example, iron and wood exposed to frost in winter or to the heat of the sun in summer have, under the same conditions, the same temperature; but on touching them the iron appears to be colder than the wood when the temperature is low, and hotter when it is high. These phenomena are due to the fact that the intensity of the sensation depends

on the rate at which heat is transferred to or from the hand. When the temperature of the iron is low, heat from the hand is distributed rapidly throughout its mass; when hot, the heat current flows in the opposite direction.

The wood, when cold, takes from the hand only sufficient heat to warm the film in immediate contact with it; when hot, it parts with heat from this film only. In consequence, it never feels markedly cold or hot.

QUESTIONS

1. If a cylinder, half brass and half wood, be wrapped with a sheet of paper and held in the flame (Fig. 306), the paper in contact with the wood will soon be scorched but that in contact with the brass will not be injured. Explain.

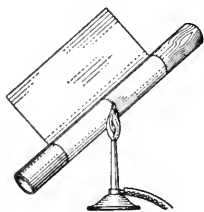

FIG. 306.

2. Why are utensils used for cooking frequently supplied with wooden handles?

3. Ice stored in ice-houses is usually packed in saw-dust. Why use saw-dust?

4. Why, in making ice-cream, is the freezing mixture placed in a wooden vessel and the cream in a metal one?

5. Water may be boiled in an ordinary paper oyster-pail over an open flame without burning the paper. Explain.

6. The so-called fireless cooker consists of a wooden box lined with felt or other non-conductor. The food is heated to a high temperature and shut up in the box. Why is the cooking process continued under these conditions?

7. Two similar cylindrical rods, one of copper and the other of lead, are covered with wax, and an end of each is inserted through a cork in the side of a vessel containing boiling water. At first the melting advances more rapidly along the lead rod, but after a while the melting on the copper overtakes that on the lead, and in the end it is 3 times as far from the hot water. Account for these phenomena. Compare the conductivities of copper and lead.

316. Convection Currents. The water in the test-tube (§ 312) remains cold at the bottom when heated at the top. If the heat is applied at the bottom, the mass of water is quickly warmed. The explanation is that in the latter case the heat is distributed by currents set up within the fluid.

The presence of these currents is readily seen if a few crystals of potassium permanganate are dropped into a beaker

of water and the tip of a gas-flame allowed to come in contact with the bottom either at one side as in Fig. 307 or at the centre as in Fig. 308.

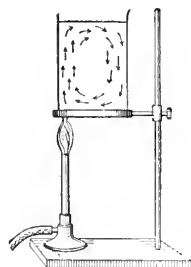

FIG. 307.—Convection currents in water heated by gas-flame placed at one side of bottom.

Such currents are called *convection currents*. They are formed whenever inequalities of temperature are maintained in the parts of a fluid. To refer to the

example just cited, the portion of the water in proximity to the gas-flame is heated and its density is reduced by expansion. The body of hot water is, therefore, buoyed up and forced to the top by the colder and heavier portions which seek the bottom.

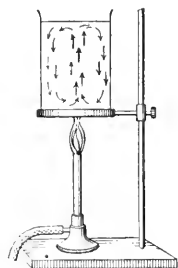

FIG. 308.—Convection currents in water heated by gas-flame placed at centre of bottom.

317. Transference of Heat by Convection. The transference of heat by convection currents is to be distinguished from conduction. In conduction, the energy is passed from molecule to molecule throughout the conductor; in convection, certain portions of a fluid become heated and change position within the mass, distributing their acquired heat in their progress. The water, heated at the bottom of the beaker, rises to the top carrying its heat with it.

318. Convection Currents in Gases. Gases are very sensitive to convection currents. A heated body always causes

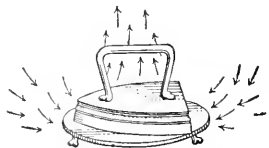

FIG. 309.—Convection currents in air about a heated flat-iron.

disturbances in the air about it. The rising smoke shows the direction of the air-currents above a fire. Hold a hot iron—say a flat-iron—in a cloud of floating dust or smoke particles (Fig. 309). The air is seen to rise from the top of the iron, and to flow

in from all sides at the bottom.

Make a box fitted with a glass front and chimneys as shown in Fig. 310. Place a lighted candle under one of the chimneys, and replace the front. Light some touch paper* and hold it over the other chimney. The air is observed to pass down one chimney and up the other.

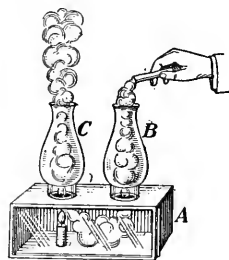

FIG. 310.—Convection currents in heated air.

319. Winds. While air-currents are modified by various forces and agencies, they are, as we have seen (§ 124), all traceable to the pressure differences which result from inequalities in the temperature and other conditions of the atmosphere.

The effects of temperature differences are but manifestations, on a large scale, of convection currents, like those in the air about the heated iron. For various causes the earth's surface is unequally heated by the sun. The air over the heated areas expands, and becoming relatively lighter, is forced upward by the buoyant pressure of the colder and heavier air of the surrounding regions.

Trade winds furnish an example. These permanent air-currents are primarily due to the unequal heating of the atmosphere in the polar and the equatorial latitudes.

* Made by dipping blotting paper in a solution of potassium nitrate and drying it.

We have an example also, on a much smaller scale, in land and sea breezes. On account of its higher specific heat, water warms and cools much more slowly than land. For this reason the sea is frequently cooler by day and warmer by night than the surrounding land. Hence, if there are no disturbing forces an off-sea breeze is likely to blow over the land during the day and an off-land breeze to blow out to sea at night (Fig. 311). Since the causes producing the changes in pressure are but local, it is obvious that these atmospheric disturbances can extend but a short distance from the shore, usually not more than 10 or 15 miles.

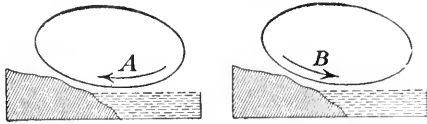

FIG. 311.—Illustration of land and sea breezes. *A*, direction of movement in sea breeze. *B*, direction of movement in land breeze.

QUERY.—Why do we, when turning on the draught of a stove or a furnace, close the top and open the bottom?

320. Application of Convection Currents—Cooking—Hot Water Supply. The distribution of heat for ordinary cooking operations such as boiling, steaming, and oven roasting and baking obviously involves convection currents.

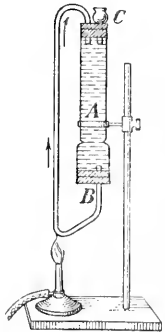

FIG. 312.—Illustration of the principle of heating water by convection currents.

When running water is available, kitchens are now usually supplied with equipment for maintaining a supply of hot water for culinary purposes. The common method of heating the water by a coil in the fire-box of a stove or furnace is illustrated in the following experiment. Use a lamp chimney as a reservoir and

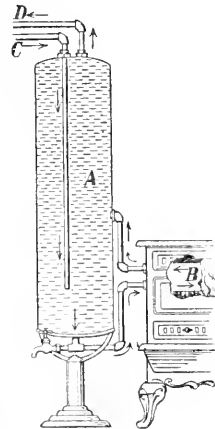

FIG. 313.—Connection in a kitchen water heater. *A* is the hot-water tank and *B* is the water-front of the stove. The arrows show the direction in which the water moves.

fit up the connecting tubes as shown in Fig. 312. Drop a

crystal or two of potassium permanganate to the bottom of the reservoir to show the direction of the water currents. Fill the reservoir and tubes through the funnel *C* and heat the tube *B* with a lamp. A current will be observed to flow in the direction of the arrow. The hot water rises to the top of the reservoir and the cold water at the bottom moves forward to be heated.

Fig. 313 shows the actual connections in a kitchen outfit. The cold water supply pipe *C* is connected with a tank in

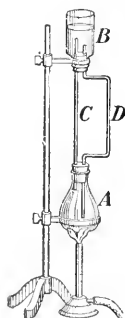

FIG. 314.—Illustration of the principle of heating buildings by hot water.

the attic or with the water-works service pipes. The hot water is drawn off through the pipe *D*.

321. Hot-Water Heating. Hot-water systems of heating dwelling houses also depend on convection currents for the distribution of heat.

The principle may be illustrated by a modification of the last experiment. Connect an open reservoir *B* with a flask, as shown in Fig. 314. Taking care not to entrap air-bubbles, fill the flask, tubes, and part of the reservoir with water. To show the direction of the currents colour the water in the reservoir with potassium permanganate. Heat the flask. The coloured water in the reservoir almost immediately begins to move downwards through the

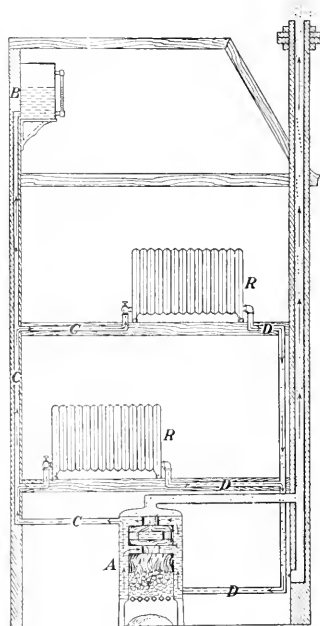

FIG. 315.—Hot-water heating system. *A*, furnace; *C, C, C*, pipes leading to radiators *R, R* and expansion tank *B*; *D, D*, pipes returning water to furnace after passing through radiators.

tube *D* to the bottom of the flask and the colourless water in *C* appears at the top of the reservoir.

In a hot-water heating system (Fig. 315) a boiler takes the place of the flask. The hot water passes through radiators in the various apartments of the house and then returns to the furnace. An expansion tank *B* is also connected with the system. Observe that, as in the flask, the hot water rises from the top of the heater and returns at the bottom.

322. Steam Heating. Steam also is employed for heating buildings. It is generated in a boiler and distributed by its own pressure through a system of pipes and radiators. The water of condensation either returns by gravitation or is pumped into the boiler.

323. Heating by Hot-Air Furnaces. Hot-air systems of heating are in very common use. In most cases the circulation of air depends on convection currents. The development of such currents by hot-air furnaces depends on the principle that if a jacket is placed around a heated body and openings are made in its top and its bottom, a current of air will enter at the bottom and escape at a higher temperature at the top. For example, a lamp shade of the form shown in Fig. 316 forms such a jacket about a hot lamp chimney. When the air around the lamp is charged with smoke a current of air is seen to pass in at the base of the shade and out at the top.



FIG. 316.—Air currents produced by placing a jacket around a heated body.

A hot-air furnace consists simply of a stove with a galvanized-iron or brick jacket *A* about it. Pipes connected with the top of the jacket convey the hot air to the rooms

to be heated. The cold air is led into the base of the jacket by pipes connected with the outside air or with the floors of the room above (Fig. 317).

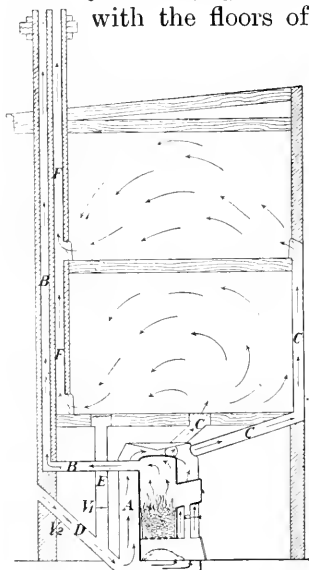

FIG. 317.—Hot-air heating and ventilating system. *A*, stove-jacket; *B*, smoke flue; *C*, warm-air pipes; *D*, cold-air pipe from outside; *E*, cold-air pipe from room; *F*, vent flue; *V*₁, valve in pipe *E*; *V*₂, valve in pipe from outside.

The experiment is typical of the means usually adopted to secure ventilation in dwelling houses. A current is made to flow between supply pipes and vents by heating the air at one or more points in its circuit.

A warm-air furnace system of heating provides naturally for ventilation, if the air to be warmed is drawn from the outside and, after being used, is allowed to escape (Fig. 317). To support the circulation the vent flue is usually heated. The

324. Ventilation. Most of the methods adopted for securing a supply of fresh air for living rooms depend on the development of convection currents.

When a lighted candle is placed at the bottom of a wide-mouthed jar, fitted with two tubes, as shown in *B* (Fig. 318), it burns for a time but goes out as the air becomes deprived of oxygen and vitiated by the products of combustion. If one of the tubes is pushed to the bottom *A* (Fig. 318), the candle will continue to burn brightly, because a continuous supply of fresh air comes in by one tube and the foul gas escapes by the other.

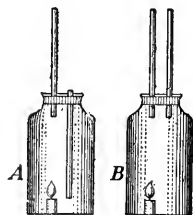

FIG. 318.—Illustration of principle of ventilation. The tubes should be at least $\frac{1}{2}$ inch in diameter.

figure shows the vent flue placed alongside the smoke flue from which it receives heat to create a draught.

The supply pipes and vent flues are, as a rule, fitted with valves V_1 , V_2 , to control the air currents. When the inside supply pipe is closed and the others opened a current of fresh air passes into and out of the house; when it is opened and the outside supply pipe and vent flue closed, the circulation is wholly within the house and the rooms are heated but not ventilated.

With a hot water or steam-heating plant ventilation must be effected indirectly. Sometimes a supply pipe is led in at the base of each radiator and fresh air drawn in by the upward current produced by the heated coils. More frequently coils are provided for warming the air before it enters the rooms. The coils are jacketed and the method for maintaining the current differs from the furnace system only in that the air is warmed by steam coils instead of by a stove. To secure a continuous circulation in large buildings under varying atmospheric conditions, the natural convection currents are often re-inforced and controlled by a power-driven fan placed in the circuit.

325. Transference of Heat by Radiation. There is a third mode by which heat may be transferred, namely by *radiation*. It is by radiation that the sun warms the earth. By getting in the shadow we shield ourselves from this direct effect; and the face may be protected from the heat of a fire by holding a book or paper between. A hot body emits radiation *in all directions* and *in straight lines*. This is quite different from convection and conduction. Transmission by convection always takes place in one direction, namely by upward currents; and conduction is not restricted to straight lines, for a bent wire conducts as well as a straight one.

326. Heat from the Sun. It must be carefully observed that the heating does not take place until the radiation which has come from a hot body falls upon a material body. The space between the hot source and the receiving body is not heated by the passage of the radiation through it.

The heat required to support life on the earth is received by radiation from the sun, but not until it reaches the earth is the heating effect produced. Our atmosphere, and especially the moisture in it, are of great importance in this connection. It acts like a protecting blanket, mitigating the intensity of the sun's direct rays, and also preventing the earth from quickly radiating into space the heat which it has received.

On a high mountain or up in a balloon the air is so rare and contains so little moisture that its protective action is negligible. In such cases the sun's rays produce intense heat in what they fall upon, but the air and any object in the shade are extremely cold.

The subject is further discussed in §§ 327 to 330 and 547 to 552.

PART VII LIGHT

CHAPTER XXXII

THE NATURE OF LIGHT; ITS MOTION IN STRAIGHT LINES

327. Light Radiation. The ear is the organ for the reception of sound, the eye that for light. The investigation of the *sensation* of vision lies with the physiologist and psychologist; in physics light is taken to be the external agency which, if allowed to act upon the eye, produces the sensation of luminosity.

For the transmission of sound, the air or some other material medium is necessary (§ 192), but such is not the case with light. Exhausting the air from a glass vessel does not impede the passage of light through it, but rather facilitates it. Again, we receive light from the sun, the stars and other heavenly bodies, and as there is no matter out in those great celestial spaces, the light must come to us through a perfect vacuum. Indeed it travels millions of millions of miles without giving up any appreciable portion of its energy to the space it comes through.

We do not understand the process by which we obtain the sensation, but it is quite certain that to produce it work must be done. We see then that the source of light,—the sun, a candle, an electric light,—radiates energy, which upon reaching the eye is used up in producing the luminous sensation.

328. How is Light Transmitted? We have been able to suggest only two methods by which energy can be transmitted from one place to another. A rifle bullet or a cannon ball has great energy, which it gives up on striking its aim. Here the energy is transferred by the forward bodily motion of a material body. But, as explained in §§ 176, 177, energy can be handed on without transference of matter, namely by wave-motion.

Now the first method, which is commonly called the 'Emission Theory,' was developed and strongly upheld by Sir Isaac Newton* and by others following him, but it has been found to be unsatisfactory. There are some experimental results contrary to it, and others which it cannot explain. If then we must discard it, we necessarily turn to the second method, which has been called the 'Wave Theory.' It was first propounded by Huygens†, but was really demonstrated by Young and Fresnel in the early years of the last century. The wave theory of light is now universally accepted by scientific men.

329. The Ether. But we cannot have waves without having a medium for them to travel in, and as the light-bearing medium is not ordinary matter we are led to assume the existence of another medium which we call the *ether*. *Light is simply a motion in the ether.*

This ether must fill the great interstellar spaces of the universe; it must also pervade the space between the molecules and the atoms of matter, since light passes freely through the various forms of matter,—solids, liquids and gases. We cannot detect it by any of our ordinary senses, we cannot see, feel, hear, taste, smell or weigh it, but as we cannot conceive of any other explanation of many phenomena, we are driven to believe in its existence. *The more one investigates the behaviour of light and other radiations, the more firmly does he become assured of the reality of the ether.*

330. Associated Radiations. It may be well to state here that the radiations which affect the eye never travel alone. Indeed those very radiations can also produce a heating effect and can excite chemical action,—in the photographic plate, for instance. But associated with the light radiation are others

* "Are not the Rays of Light very small Bodies emitted from shining Substances?" Newton's *Opticks* (1704.)

† Christian Huygens presented his Treatise on Light to the Royal Academy of Sciences, Paris, in 1678. It was published in Leyden in 1690.

which do not affect the eye at all, but which assist healthy growth and destroy obnoxious germs, give us warmth necessary for life, produce chemical effects as revealed in the colours of nature, or give us communication by wireless telegraphy.

These and many other effects are due to undulations of the ether, the chief difference among them being in the lengths of the waves.

We can *see* the waves moving on the surface of water or along a cord; we can *feel* the air, and with some effort, perhaps, can comprehend its motions; but to form a notion of how the ether is constructed and how it vibrates is a matter of excessive difficulty and indeed largely of pure conjecture. A very useful picture to have in one's mind is to think of the eye as joined to a source of light by cords of ether, and to consider the source as setting up in these cords transverse vibrations, which travel to the eye and give the luminous sensation.

331. Waves and Rays. Though light is a form of energy, and is transferred from place to place by means of *waves*, we usually speak of it as passing in *rays*.

Let the light spread out in all directions from a source A (Fig. 319). The waves will be concentric spheres $S_1, S_2, S_3 \dots$, but the light will pass along the radii $R_1, R_2, R_3 \dots$, of these spheres. The rays thus are the paths along which the waves travel, and it is seen that the ray is perpendicular to the wave-surface.*

If we consider a number of rays moving out from A (Fig. 320) we have what is known as a divergent pencil a , and the waves are concentric spheres continually growing larger. If the rays are coming together to a point we have a convergent pencil b ,

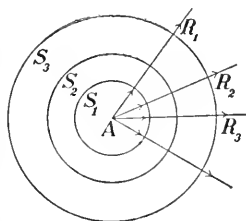

FIG. 319.—The waves are spheres with A as centre; the rays are radii of these spheres.

* This discussion refers to homogeneous or isotropic matter.

and the waves are concentric spheres continually growing smaller. If now the rays are parallel, as in *c*, we have a



FIG. 320.—A convergent pencil, *b* ; a divergent pencil, *a* ; a parallel beam, *c*.

parallel beam, and the waves are plane surfaces, perpendicular to the rays. Such rays are obtained if the source is at a very great distance, so great that a portion of the sphere described with the source as centre might be considered a plane.

QUERY.—What becomes of the waves of a convergent pencil (*b*, Fig. 320) after they come to a point ?

332. Light Travels in Straight Lines. In a homogeneous medium the rays are straight lines. We assume the truth of this in many every-day operations. The carpenter could not judge that an edge was straight nor could the marksman point his rifle properly were he not sure that three objects are precisely in a straight line when the light is *just* prevented from passing from the first to the third by the object between.

When light is admitted into a darkened room—a knot-hole in a barn, for instance—we can often trace the straight *course* of the rays by the dust-particles in the air. The rays, themselves, cannot be seen, but when they fall upon the particles of matter these are illuminated and send light-waves to the eye.

333. The Pin-hole Camera. An interesting application of the fact that light moves in straight lines is in the pin-hole camera. Let *MN* (Fig. 321) be a box having no ends. In front of it place a candle, or other bright object, *AB*, and over the front end stretch tin-foil. In this prick a hole *C* with a pin, and over the back of the box stretch a thin sheet of paper.

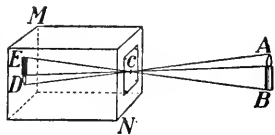

FIG. 321.—Pin-hole camera. *C* is a small hole in the front and an inverted image of the candle *AB* is seen on the back of the box.

The light from the various portions of AB will pass through the hole C and will form on the paper an image DE , of the candle. This can be seen best by throwing over the head and the box a dark cloth. (Why?) The image is inverted, since the light travels in straight lines, and the rays cross at C .

If now we remove the paper, and for it substitute a sensitive photographic plate, a 'negative' may be obtained just as with an ordinary camera; indeed the perspective of the scene photographed will be truer than with most cameras. The chief objection to the use of the pin-hole camera is that with it the exposure required, compared to that with the ordinary camera, is very long.

It is evident that to secure a sharp, clear image the hole C must be small. Suppose that it is made twice as large. Then we may consider each half of this hole as forming an image, and as these images will not exactly coincide, indistinctness will result. On the other hand the hole must not be too small. As it is reduced in size other phenomena, known as diffraction effects, are obtained. These effects show that, in all strictness, the light does not travel precisely in straight lines after all. The size of the hole required depends on the wave-length of light and the length of the camera box.

334. Theory of Shadows. Since the rays of light are straight, the space behind an opaque object will be screened from the light and will be *in the shadow*. If the source of the light is small the shadows will be sharply defined, but if it is of some size the edges will be indistinct.

Let A (Fig. 322) be a small source,—an arc lamp, for instance,—and let B be an opaque ball. It will cast on the screen CD a circular shadow with sharply defined edges. But if the source is a body

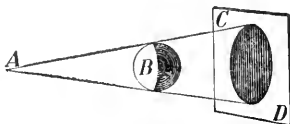

FIG. 322.—If the source be small the shadow will be sharp. A is the source, B the object, CD the shadow.

of considerable size,* such as the sphere S (Fig. 323), then it is evident that the only portion of space which receives no light at all is the cone behind the opaque sphere E . This is called the *umbra*, or simply the *shadow*, while the portion beyond it which receives a part of the light from S is the *penumbra*.

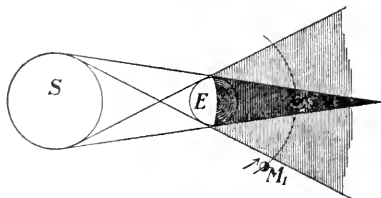

FIG. 323.— S is a large bright source, and E an opaque object. The dark portion is the *shadow*, the lighter portion the *penumbra*.

Suppose M is a body revolving about E in the direction indicated. In the position 1 it is just entering the penumbra; in the second position it is entirely within the shadow.

If S represents the sun, E the earth, and M the moon, the figure will illustrate an eclipse of the moon. For an eclipse of the sun, the moon must come between the earth and the



FIG. 324.—Showing how an eclipse of the sun is produced. A person at a cannot see the sun.

sun, as shown in Fig. 324. Only a small portion of the earth is in the shadow, and in order to see the sun totally eclipsed an observer must be at a on the narrow "track of totality."

335. Transparent, Opaque and Translucent Bodies. Transparent bodies, such as glass, mica, water, etc., allow the light to pass freely through them. Opaque substances entirely obstruct the passage of light; while translucent bodies, such as ground-glass, oiled paper, etc., scatter the light which falls upon them, but a portion is allowed to pass through.

* A lamp with a spherical porcelain shade may be used.

QUESTIONS AND PROBLEMS

1. A photograph is made by means of a pin-hole camera, which is 8 inches long, of a house 100 feet away and 30 feet high. Find the height of the image?

2. Why does the image in a pin-hole camera become fainter as it becomes larger (*i.e.*, by using a longer box, or pulling the screen back)?

3. Why is the shadow obtained with a naked arc lamp sharp and well-defined? What difference will there be when a ground-glass globe is placed around the arc?

4. On holding a hair in sunlight close to a white screen the shadow of the hair is seen on the screen, but if the hair is a few inches away, scarcely any trace of the shadow can be observed. Explain this.

5. The sun's diameter is 864,000 miles, that of the earth, 8,000 miles. If the distance from the earth to the sun is 93,000,000 miles, find the length of the earth's shadow (Fig. 323). Calculate the diameter of this shadow at the mean distance of the moon from the earth. This distance is approximately 240,000 miles.

6. The earth when nearest the sun (which occurs about January 1) is $91\frac{1}{2}$ millions of miles away, and the moon when nearest the earth is at a distance of 221,600 miles. These distances are from the centre of the earth. Supposing an eclipse of the sun to take place under these circumstances, find the width of the shadow (σ , Fig. 324) cast on the earth, taking the diameter of the moon to be 2,160 miles.

CHAPTER XXXIII

PHOTOMETRY

336. Decrease of Intensity with Distance from the Source.

Let a small square of cardboard BC be held at the distance of one foot from a small source of light A (Fig. 325), and one foot behind this place a white screen DE .

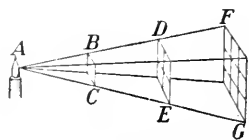

FIG. 325.—Area of DE is 4 times, and area of FG is 9 times that of BC .

The shadow cast by BC on DE is a square, each side of which is twice that of BC , and hence its area is *four* times that of BC . Next, hold the screen at FG , one foot further away, or three feet from A . The shadow of

BC will now have its linear dimensions three times those of BC and its area nine times that of BC ; and so on. The area of the shadow varies as the square of the distance from the source A .

Suppose, now, a white screen, (a piece of paper), be held at BC . The light A will illuminate it with a certain intensity which we shall denote by I_1 . If the screen is held at DE the same light which fell on one square inch when at BC will now fall on four square inches, and hence the intensity of illumination I_2 will be $\frac{1}{4}$ of I_1 . If placed at FG the same amount of light will be spread over 9 square inches, and the illumination I_3 is equal to $\frac{1}{9}$ of I_1 . If the screen be n times as far from A as BC is, the illumination I_n will be $\frac{1}{n^2}$ of I_1 . Thus we obtain the law: *The intensity of illumination varies inversely as the square of the distance from the source of light.*

This is the fundamental law upon which all methods of comparing the powers of different sources of light are based.

It should be carefully observed that for this law to hold, the source of light must be small and must radiate freely in

all directions. The headlight of a locomotive, for instance, projects the light mostly in one direction, and the decrease in intensity of illumination will not vary according to the above law.

337. Rumford's Photometer. To compare two sources of light we require some convenient method of determining equality of illumination, and various instruments, known as *photometers*, have been devised for this purpose. Suppose we wish to compare the illuminating powers of the two lamps L_1 and L_2 . The method introduced by Rumford is to stand an opaque rod R (Fig. 326) vertically before a screen AB , and allow shadows from the two lamps to be cast on the screen.

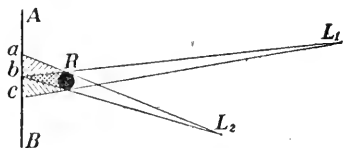

FIG. 326.—Rumford's shadow photometer. The lights L_1 , L_2 are adjusted until the shadows cast by a rod R on the screen are equally dark.

If the screen is of ground-glass it should be viewed from the side away from the lamps; if of opaque white paper (white blotting paper is best) the observer should be on the same side as the lamps.

It is evident that the portion ab is illuminated only by the lamp L_1 , and the portion bc only by the lamp L_2 .

Now move the lamps until the portions ab , bc are equally bright (or equally dark), and then measure the distance of L_1 from ab and of L_2 from bc . Let these distances be d_1 , d_2 , respectively. We can now calculate the ratio between the illuminating powers of the lamps.

Let the distances d_1 , d_2 be given in feet. Hold a piece of paper 1 foot from L_1 ; let the intensity of illumination be I_1 . In the same way when held 1 foot from L_2 let the intensity of illumination be I_2 .

It is evident then that

$$\frac{I_1}{I_2} = \frac{L_1}{L_2}.$$

Now the lamp L_1 produces a certain intensity of illumination on the portion ab which is distant d_1 feet from L_1 . Let this be I . Then

$$\frac{I}{I_1} = \frac{1}{(d_1)^2}.$$

Similarly, since the intensity of illumination of bc is the same as of ab , it also is I , and we must have

$$\frac{I}{I_2} = \frac{1}{(d_2)^2}.$$

$$\text{Hence } \frac{I}{I_2} \div \frac{I}{I_1} = \frac{1}{(d_2)^2} \div \frac{1}{(d_1)^2},$$

$$\text{Or } \frac{I_1}{I_2} = \left(\frac{d_1}{d_2}\right)^2.$$

$$\text{But } \frac{I_1}{I_2} = \frac{L_1}{L_2}, \text{ and so } \frac{L_1}{L_2} = \left(\frac{d_1}{d_2}\right)^2.$$

338. The Bunsen Photometer. The essential part of this photometer is a piece of unglazed paper with a grease-spot on it. Such a spot is more translucent than the ungreased paper, so that if the paper is held before a lamp the grease-spot appears brighter than the other portion, while if held behind the lamp it appears darker.

Now move the grease-spot screen between the two light-

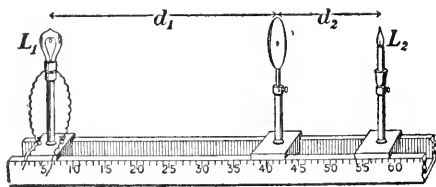

FIG. 327.—The Bunsen grease-spot photometer.

sources L_1, L_2 (Fig. 327) to be compared until it is equally bright all over its surface. Then it is evident that what illumination the screen loses by the light from L_1 passing through is

precisely compensated by the light from L_2 transmitted through it. Thus the intensity of illumination due to each

lamp is the same. Hence, if d_1, d_2 are the distances from the screen of L_1, L_2 , respectively,

$$\frac{L_1}{L_2} = \left(\frac{d_1}{d}\right)^2,$$

as before.

339. Joly's Diffusion Photometer. Two pieces of paraffin wax, each about 1 inch square and $\frac{1}{4}$ inch thick are cut from the same block of paraffin, carefully made of the same thickness and then put together with tin-foil between them (Fig. 328). This is adjusted between the two lamps to be compared, until the two pieces are equally illuminated, at which time the line of separation disappears.

This is a simple and very useful photometer. The block of paraffin should be viewed through a tube, using a single eye.

For the block of paraffin one may substitute a wooden prism having two faces covered with unglazed paper, and the edge being turned towards the experimenter.

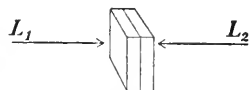

FIG. 328.—Joly Diffusion Photometer, consisting of two similar blocks of paraffin, set close together.

All photometric work should be done in a darkened room, and the eyes should be shielded from the direct light from the lamps which are being compared. There will usually be difficulty in adjusting the photometer due to a difference in the colour of the lights. This cannot be avoided, however.

340. Verification of the Law of Inverse Squares. To do this let us use the Joly photometer (Fig. 329). Place 1 candle at one end of a board and 4 candles at the other. Now move the photometer until the line between the paraffin blocks disappears, and measure its distance from the 1 candle and the 4 candles. The latter will

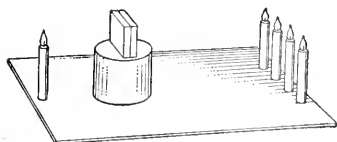

FIG. 329.—If the blocks are equally illuminated the 4 candles are twice as far from the photometer as the single candle.

be twice the former. Next, replace the 4 candles by 9 and adjust as before. The distance from the 9 candles will be 3 times that from 1.

Thus if the distance is doubled the illumination is reduced to $\frac{1}{4}$, since it requires 4 times as many candles to produce equality. In the same way if the distance were n times as great we should require n^2 candles to produce an illumination equal to that given by the single candle.

341. Standards of Light. By the photometer we can accurately compare the strengths of two sources of light, but to state definitely the illuminating power of any lamp we should express it in terms of some fixed standard unit. We have definite standard units for measuring length, mass, time, heat, and most other quantities met with in physics; but no perfectly satisfactory standard of light has yet been devised.

The one most commonly used is the *candle*. The British standard candle is made of spermaceti, weighs 6 to the pound avoirdupois, and burns 120 grains per hour. The strength varies however with the state of the atmosphere and with the details of the manufacture of the wick. Yet, notwithstanding this inconstancy, it is usual to express the illuminating power of a source in terms of the standard candle.

A standard much used in scientific work is the Hefner lamp

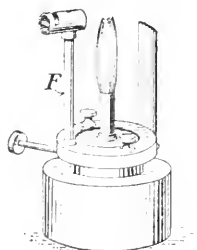

FIG. 330.—The Hefner standard lamp. The attachment *F* is for accurately adjusting the height of the flame.

(Fig. 330). This is a small metal spirit-lamp with a cylindrical bowl 7 cm. in diameter and 4 cm. high. The wick-holder is a German-silver tube 8 mm. in interior diameter, 0.15 mm. thick, and 25 mm. high. The wick is carefully made to just fit the tube, and the height of the flame is adjusted to be 4 cm. The liquid burned is pure amyl acetate. The lamp is very constant, and its power is given as 98 per cent. of the British candle.

QUESTIONS AND PROBLEMS

1. Distinguish between *illuminating power* and *intensity of illumination*.
2. When using a Rumford photometer (Fig. 326) the distance L_1b was found to be 20 inches and L_2b was 50 inches. Compare the illuminating powers of L_1 and L_2 .
3. Two equal sources of light are placed on opposite sides of a sheet of paper, one 12 inches and the other 20 inches from it. Compare the intensity of illumination of the two sides of the paper.
4. A lamp and a candle are placed 2 m. apart, and a paraffin-block is in adjustment between them when 42 cm. from the candle. Find the candle-power of the lamp.
5. For comfort in reading the illumination of the printed page should be not less than 1 candle-foot (*i.e.*, 1 candle at a distance of 1 foot). How far might one read from a 16 candle-power lamp and still have sufficient illumination?
6. A candle and a gas-flame which is four times as strong are placed 6 feet apart. There are two positions on the line joining these two sources where a screen may be placed so that it may be equally illuminated by each source. Find these positions.

CHAPTER XXXIV

THE VELOCITY OF LIGHT

342. Roemer's Great Discovery. Galileo constructed the telescope in 1609 and the first fruit of its use was the discovery that Jupiter was attended by four moons. At present we know that the planet has eight moons, but while the four first discovered can be seen with a small telescope, the last four are very small bodies and very difficult to see.

Roemer, a young Danish astronomer, while at the Paris Observatory, made an extended series of observations on Jupiter's First Satellite; and inequalities in these observations led him to announce

in 1675 the discovery that light travelled with a finite velocity.

In the figure (Fig. 331) let S be the sun, E_0, E', E'', E_c the earth in various positions in its orbit, J_1, J_2 the planet Jupiter in two positions, and M the moon under observation. In the position $S E_0 J_1$, in which the planet and the sun

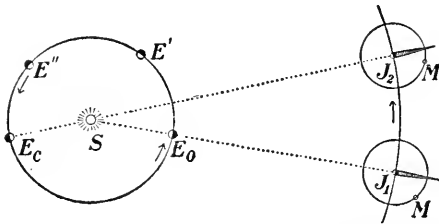

FIG. 331.—Illustrating the eclipse of Jupiter's satellite. S is the sun, E the earth, J Jupiter, and M its satellite. When the satellite passes into the shadow cast by J it cannot be seen from E .

are on opposite sides of the earth, Jupiter is said to be in *opposition*, while in the position $E_c S J_2$ in which the planet and the sun appear to be a straight line, as seen from the earth, Jupiter is said to be in *conjunction*.

Every time the moon revolves about Jupiter it plunges into its shadow and is *eclipsed*. Now the First Moon is neither the largest nor the brightest, but as it makes a revolution in $42\frac{1}{2}$ hours its motion is rapid, and the time of an eclipse can be determined with considerable accuracy.

Suppose we observe successive eclipses near the time of opposition. We thus obtain the interval between them, and by taking multiples of this we can tabulate the times for future eclipses. Now Roemer found that the observed and tabulated times did not agree,—that as the earth moved to E', E'' and E_c , continually getting farther from the planet, the observed time lagged more and more behind the tabulated time, until when at E_c , and Jupiter at J_2 , the difference

between the times had grown to 16 m. 40 s. or 1000 seconds.* As the earth moved round to opposition again the inequality disappeared and the times observed and tabulated coincided.

Roemer explained the peculiar observations by saying that at conjunction the light travels the distance $E_c J_2$, which is greater than the distance $E_c J_1$ travelled at opposition by the diameter of the earth's orbit, and hence the observed time at E_c should be later than the tabulated time by the time required to travel this extra distance. Taking the diameter of the orbit to be 186,000,000 miles, the velocity is

$$\frac{186,000,000}{1000} = 186,000 \text{ miles per second.}$$

343. Other Determinations. Roemer's explanation was not generally accepted until long after his death (1710). In 1727 Bradley, the Astronomer Royal of England, discovered the "aberration of light," and fully confirmed Roemer's results. In more recent times the velocity of light has been directly measured on the earth's surface. In 1862 Foucault, a French physicist, actually measured the time taken by light to travel 40 m., the entire experiment being performed in a single darkened room. Very accurate measurements have been made by others, especially by Michelson and Newcomb in the United States and Cornu and Perrotin in France, and the result is 299,860 kilometres or 186,330 miles per second.

344. Illustrations of Velocity of Light. The speed of light is so enormous that one can hardly appreciate it. It would travel about the earth $7\frac{1}{2}$ times in a single second. The distance from the earth to the sun is 93,000,000 miles. A celestial railway going 60 miles an hour without stop would require 175 years to traverse this distance, but light comes from the sun to us in $8\frac{1}{3}$ minutes! And yet the time taken for the light to reach us from the nearest of the fixed stars (named Alpha Centauri) is 4.3 years. From Sirius, our brightest fixed star, the time is 8.6 years, while from the Pole Star it is 44 years. That star could be blotted out and we would not know of it until 44 years afterwards.

345. Velocity in Liquids and Solids. Michelson measured the velocity of light in water and in carbon bisulphide, and found it less than in air in both cases. Indeed the velocity in air is $1\frac{1}{3}$ times that in water and $1\frac{3}{4}$ times that in carbon bisulphide. These results will be referred to again, when dealing with refraction. We shall find that the velocity in all transparent solids and liquids is less than in air.

*This is the modern value; Roemer's result was 22 m.

CHAPTER XXXV

REFLECTION OF LIGHT: PLANE MIRRORS

346. The Laws of Reflection. Let a lighted candle, placed in front of a sheet of thin plate glass, stand on a paper

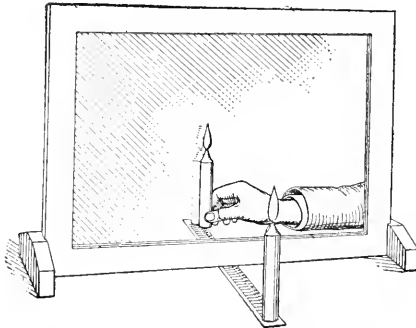

FIG. 332.—A lighted candle stands in front of a sheet of plate glass (not a mirror). Its image is seen by the experimenter, who, with a second lighted candle in his hand, is reaching round behind and trying to place it so as to coincide in position with the image of the first candle.

(or other) scale arranged perpendicular to the surface of the glass (Fig. 332). We see an image of the candle on the other side. Now move a second candle behind the glass until it coincides in position with the image.

On examining the scale it will be found that the two candles are both on the paper scale and at equal distances from the glass plate. We can state the LAW OF REFLECTION, then, in this way:—

If an object be placed before a plane mirror its image is as far behind the mirror as the object is in front of it, and the line joining object and image is perpendicular to the mirror.

Thus light goes from the candle, strikes the mirror, from which it is reflected, and reaches the eye as though it came from a point as far behind the mirror as the candle is in front of it. Of course the image is not real, that is, the light does not actually go to it and come from it—it only appears to do so. But the deception is sometimes perfect and we take the

image for a real object. This illusion is easily produced if the mirror is a good one and its edges are hidden by drapes or in some other way.*

This law of reflection can be stated in another way. Let MN (Fig. 333) be a section of a plane mirror. Light proceeds from A , strikes the mirror and is reflected, a portion being received by the eye E . To this eye the light *appears* to come from B , where $AM = MB$ and AB is perpendicular to MN .

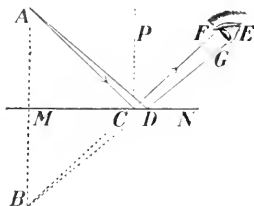

FIG. 333.— AC is an incident ray, CF the reflected ray, and CP the normal to the surface MN . Then angle of incidence ACP is equal to angle of reflection FCP .

Consider the ray AC , which, on reflection, goes in the direction CF .

In the triangles AMC , BMC we have $AM = MB$, MC is common to the two triangles, and angle $AMC =$ angle BMC , each being a right-angle.

Hence the triangles are equal in every respect, and so the angle $ACM =$ angle BCM .

But angle $BCM =$ angle FCN , and hence the angles ACM and FCN are equal to each other.

From C let now CP be drawn perpendicular to MN . It is called the *normal* to the surface at C . At once we see angle $ACP =$ angle FCP .

Now AC is defined to be the incident ray, CF the reflected ray, ACP the angle of incidence and FCP the angle of reflection. Hence we can state our law of reflection thus:

The angle of incidence is equal to the angle of reflection.

This statement of the law, which is precisely equivalent to the other, is sometimes more convenient to use.

*Wordsworth in "Yarrow Unvisited" refers to a case of perfect reflection:

"The swan on still St. Mary's Lake
Floats double, swan and shadow."

Another law should be added, namely,—

The incident ray, the reflected ray and the normal to the surface are all in one plane.

347. Law of Reflection in Accordance with the Wave Theory. The law of reflection, which we obtained experimentally, is just what we should expect if light is a

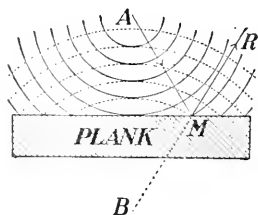

FIG. 334.—Waves on still water reflected from a plank lying on its surface.

wave-motion. Let a stone be thrown into still water. Waves, in the form of concentric circles, spread out from the place *A* (Fig. 334) where it entered the water. If a plank lies on the surface near by, the waves will strike it and be reflected from it, moving off as circular waves whose centres *B* are as far behind the reflecting edge as *A* is in front of it. In the figure the dotted circles are the reflected waves. *AM* is an incident and *MR* the reflected "ray."

The reflection of circular waves is well illustrated in Fig. 335, which is made from an instantaneous photograph* of waves on the surface of mercury. The waves were produced by attaching a light "style" to one prong of a tuning-fork and making it vibrate with the end just touching the surface. A triangular piece of glass lies on the surface and from it the waves are reflected, their

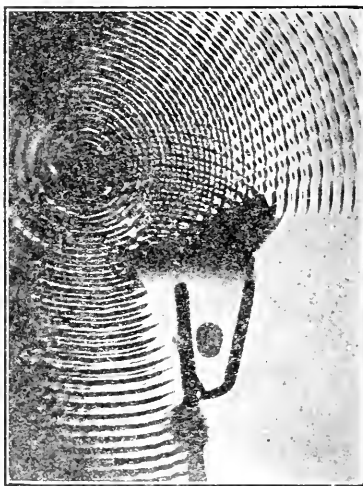

FIG. 335.—The circular waves on the surface of mercury spread out and are reflected from a glass plate. (From a photograph.)

*Taken, with the aid of an electric spark, by J. H. Vincent, of London, England.

centres being as far behind the reflecting edge as the source is in front of it.

348. Regular and Irregular Reflection. Mirrors are usually made of polished metal or of sheet glass with a coating of silver on the back surface. When light falls on a mirror it is reflected in a definite direction and the reflection is said to be *regular*. Reflection is also regular from the still surfaces of water, mercury and other liquids.

Now an unpolished surface, such as paper, although it may appear to the eye or the hand as quite smooth, will exhibit decided inequalities when examined under a microscope. The surface will appear somewhat as in Fig. 336, and hence the normals at the various parts of the surface will not be parallel to each other, as they are in a well-polished surface. Hence the rays when reflected will take various directions and will be scattered.

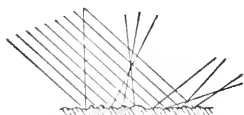

FIG. 336. — Scattering of light from a rough surface.

It is by means of this scattered light that objects are made visible to us. When sunlight is reflected by a mirror into your eyes you do not see the mirror but the image of the sun formed by the mirror. Again, if a beam of sunlight in a dark room falls on a plate of polished silver, practically the entire beam is diverted in one definite direction, and no light is given to surrounding bodies. But if it falls on a piece of chalk the light is diffused in all directions, and the chalk can be seen. It is sometimes difficult to see the smooth surface of a pond surrounded by trees and overhung with clouds, as the eye considers only the reflected images of these objects; but a faint breath of wind, slightly rippling the surface, reveals the water.

349. How the Eye receives the Light. An object AB

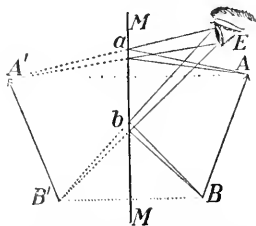

FIG. 337.—How an eye sees the image of an object before a plane mirror.

(Fig. 337) is placed before a plane mirror MM , and the eye of the observer is at E . Then the image $A'B'$ is easily drawn. The light which reaches the eye from A will appear to come from A' , which is the image of A and which is as far behind MM as A is before it.

It is therefore by the pencil AaE that the point A is seen. In the same way the point B is seen by the small pencil BbE , and similarly for all other points of the object.

It will be observed that when the eye is placed where it is in the figure, the only portion of the mirror which is used is the small space between a and b .

An interesting exercise for the student is to draw a figure showing that, for a person standing before a vertical mirror to see himself from head to foot, the mirror need be only half his height.

350. Lateral Inversion. The image in a plane mirror is not the exact counterpart of the object producing it. The right hand of the object becomes the left hand of the image. If a printed page is held before the mirror the letters are erect but the sides are interchanged. This effect is known as *lateral inversion*. By writing a word on a sheet of paper and at once pressing on it a sheet of clean blotting-paper the writing on the blotting-paper is inverted; but if it is held before a mirror it is

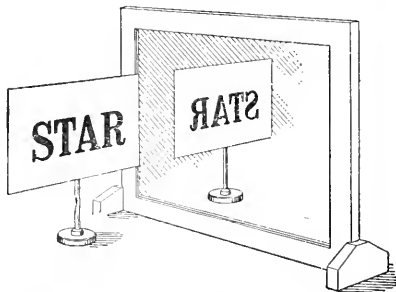

FIG. 338.—Illustrating "lateral inversion" by a plane mirror.

reinverted and becomes legible. The effect is illustrated in Fig. 338, showing the image in a plane mirror of the word STAR. It may be remarked, therefore, that on looking in a mirror we do not 'see ourselves as others see us.'

351. Reflections from Parallel Mirrors. Let us stand two mirrors on a table, parallel to each other, and set a lighted candle between them. An eye looking over the top of one mirror at the other will see a long vista of images stretching away behind the mirror. These are produced by successive reflections.

In Fig. 339, *I* and *II* are the mirrors and *O* the candle. A_1 is

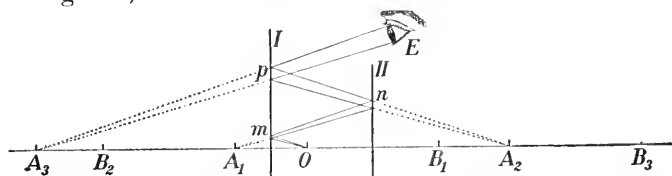

FIG. 339.—Showing many images produced by two mirrors *I*, *II*, parallel to each other.

the image of *O* in *I*, A_2 the image of A_1 in *II*, A_3 that of A_2 in *I*, and so on. Also B_1 is the image of *O* in *II*, B_2 that of B_1 in *I*, B_3 that of B_2 in *II*, and so on. The path of the light which produces in the eye the third image A_3 is also shown. It is reflected three times, namely, at *m*, *n* and *p*, and from the figure it will be seen that the actual path *OmpE*, which the light travels, is equal to the distance $A_3 E$, from the image to the eye.

352. Images in Inclined Mirrors. Let the mirrors M_1 , M_2 (Fig. 340) stand at right angles to each other and *O* be a candle between. There will be three images, *A* being the first image in M_1 , *B* the first image in M_2 , while *C* is the image of *A* in M_2 or of *B* in M_1 , these two coinciding.

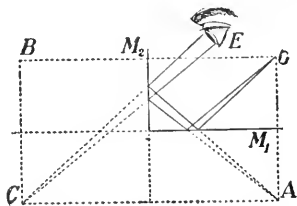

FIG. 340.—Images produced by two mirrors placed at right angles.

353. The Kaleidoscope. If the mirrors are inclined at 60° the images will be formed at the

places shown in Fig. 341. They are all located on the circumference of a circle having the intersection of the mirrors as its centre, and an inspection of the figure will show how to draw them.

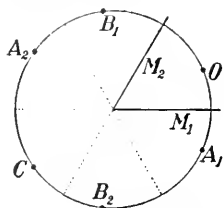

FIG. 341. — Images produced by mirrors inclined at an angle of 60° .

The kaleidoscope is a toy consisting of a tube having in it three mirrors forming an equilateral triangle, with bits of coloured glass between. The multiple images produce some very pleasing hexagonal figures. It was invented in 1816 by Sir David Brewster and created a great sensation.

QUESTIONS AND PROBLEMS

1. Why is a room lighter when its walls are white than when covered with dark paper?
2. The sun is 30° above the horizon and you see its image in still water. Find the size of the angles of incidence and reflection in this case.
3. Two mirrors are inclined at 45° and a candle is placed between them. By means of a figure show the position of the images. Do the same for mirrors inclined at 72° .
4. Two mirrors are inclined at an angle of 60° . A ray of light travelling parallel to the first mirror strikes the second, from which it is reflected, and, falling on the first, is reflected from it. Show that it is now moving parallel to the second mirror.
5. The object O between two mirrors standing parallel to each other (Fig. 339) is 8 inches from A and 12 inches from B . Find the distances $A_1 B_1$, $A_2 B_2$, $A_3 B_3$.

CHAPTER XXXVI

REFLECTION FROM CURVED MIRRORS

354. The Curved Mirrors used in Optics; Definitions.

The curved mirrors used in optics are generally segments of spheres. If the reflection is from the outer surface of the sphere the mirror is said to be *convex*; if from the inner surface, *concave*.

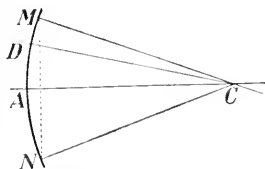

FIG. 342.—A section of a spherical mirror.

In Fig. 342 MAN represents a section of a spherical mirror. C , the centre of the sphere from which the mirror is cut, is the *centre of curvature*, and CM , CA or CN is a *radius of curvature*;

MN is the *linear*, and MCN the *angular*, aperture; A , the middle point of the face of the mirror is the *vertex*; CA is the *principal axis*, and CD , any other straight

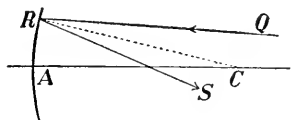

FIG. 343.—Reflection from a concave mirror.

line through C , is a *secondary axis*.

355. How to Draw the Reflected Ray. The laws of reflection hold for curved as well as for plane mirrors. Let QR (Fig. 343) be a ray incident on the concave mirror at R . By joining R to C we obtain the normal at R , and by making CRS (the angle of reflection) equal to CRQ (the angle of incidence), we have RS , the reflected ray.

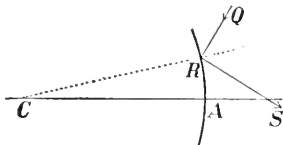

FIG. 344.—Reflection from a convex mirror.

In Fig. 344 is shown the construction for a convex mirror, QR being the incident and RS the reflected ray.

356. Principal Focus.

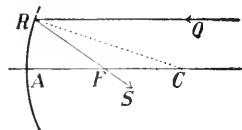

FIG. 345.—The ray QR , parallel to the principal axis AC , on reflection passes through the principal focus F .

In Fig. 345 let QR be a ray parallel to the principal axis; then, making the angle $CRS = \text{angle } CRQ$, we have the reflected ray RS . But since QR is parallel to AC , angle $CRQ = \text{angle } RCF$. Hence angle $FRC = \text{angle } FCR$, and the sides FR , FC are equal.

Now if R is not far from A , the vertex, FR and FA are nearly equal, and hence AF is approximately equal to FC , i.e., the reflected ray cuts the principal axis at a point approximately midway between A and C .

It is evident, then, that a beam of rays parallel to the principal axis, striking the mirror near the vertex, will be converged by the concave mirror to a point F , midway between A and C . This point is called the *principal focus*, and AF is the *focal length* of the mirror. Denoting AF by f and AC by r , we have $f = r/2$.

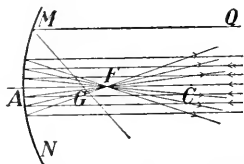

FIG. 346.—A beam of rays parallel to the principal axis passes, on reflection, through F , the principal focus.

In the case shown in Fig. 346 the rays actually pass through F which is therefore called a *real focus*.

Rays which strike the mirror at some distance from A do not pass precisely through F . For instance, the ray QM cuts the axis at G ; this *wandering* from F is called *aberration*, which amounts to FG for this ray.

For a convex mirror the same method is followed. In Fig. 347 a beam parallel to the principal axis is incident near the vertex. The reflected rays diverge in such a way that if produced backwards they pass through F , the principal focus. In this case the rays do not actually pass through F , but only appear to come from it.

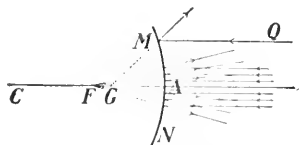

FIG. 347. Showing reflection of a parallel beam from a convex mirror.

For this reason F is called a *virtual* focus. In the figure is also shown a ray QM , which strikes the mirror at some distance from the vertex. Upon reflection this appears to come from G , and FG is the aberration.

357. Experimental Determination of the Focal Length.

Hold a concave mirror in the sun's rays or in a parallel beam from a projecting lamp, and shake chalk-dust in the air. In this way one can see how the light passes through the air, strikes the mirror, converges to a point and then spreads out again. This point is the principal focus, and by placing a piece of paper there its position can be well determined. Its distance from the vertex is the focal length required.

If a sheet of paper with a hole cut in it is placed over the mirror so as to use only those rays which strike the mirror near its vertex, the light will converge more accurately to a point but the image will not be so bright.

For a convex mirror the method is not quite so direct. Make a round paper disc to cover the face of the mirror, and in it cut two slits at a measured distance apart (a , Fig. 348). Use a screen like that shown (b , Fig. 348). Now let the sun's rays pass through the hole in the screen and strike the small uncovered spots m , p , of the mirror. Then nm is the incident ray, which is reflected along mL , and qp , that which is reflected along pM . There will be two bright spots at L , M , on the back surface of the screen. Move the mirror until the distance $LM = 2mp$.

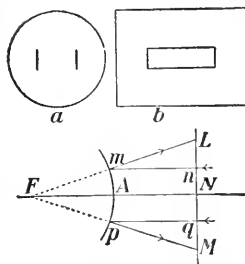

FIG. 348.—Illustrating a method of finding the focal length of a convex mirror.

Now, from the figure we see that LFN and Lmn are similar triangles, and if $LN = 2Ln$, then $FN = 2mn = 2AN$, or $FA = AN$, and hence the focal length is equal to the distance of the screen from the mirror.

358. Explanation by the Wave Theory. The behaviour of curved mirrors can be easily accounted for by means of the wave theory. In Fig. 349 $a b$, $a_1 b_1$, $a_2 b_2$, . . . represent plane waves moving forward to the concave mirror. The waves reach the outer portions of the mirror first and are turned back, in this way being changed into spherical waves which contract, pass through F and then expand again.

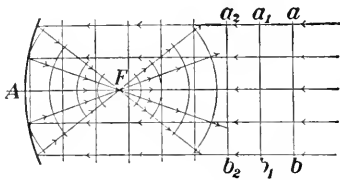

FIG. 349.—Showing how plane waves by reflection at a concave mirror are changed to spherical waves.

This action of a concave mirror is well illustrated in Fig. 350 from an instantaneous photograph of ripples on the surface of mercury. The plane waves were produced by a piece of glass fastened to one prong of a tuning-fork. They move forward and meet a concave reflector, by which they are changed into circular waves converging to the principal focus. They pass through this and then expand again.



FIG. 350.—Instantaneous photograph of waves on the surface of mercury. (By J. H. Vincent.)

EXERCISE.—Draw for a convex mirror the figure corresponding to Fig. 349.

359. Conjugate Foci. We have seen that light rays moving parallel to the principal axis are brought to a focus, real or virtual, by a spherical mirror, but a focus can be obtained as well with light not in parallel rays. For instance, let the light diverge from P (Fig. 351); after reflection from the concave mirror it converges to P' .

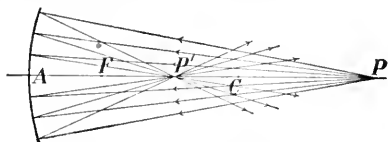

FIG. 351.—Conjugate foci in a concave mirror. P and P' are conjugate.

Now it is evident that if the light originated at P' , it would be converged by the mirror to P . Each point is the image of the other and they are called *conjugate foci*.

In the case shown in Fig. 351 both foci are real, since the rays which come from one actually pass through the other.

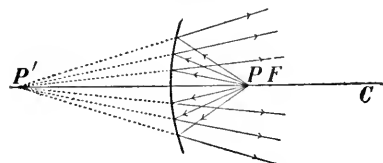

FIG. 352.—Conjugate foci in a concave reflector, one being virtual.

It is possible, however, for one of them to be virtual. Such a case is shown in Fig. 352. Here P' is conjugate to P , but is virtual. It will be noticed that P is between the mirror and F .

Under these circumstances the conjugate focus is virtual, under all others it is real.

EXERCISE.—Draw the *waves* in these and in other cases of conjugate foci, taking P at various positions on the axis.

360. Illustrative Experiments. Into a darkened room take a concave mirror, and at the other end of the room place a lighted candle facing the mirror. The position of the image can be found by catching it on a small screen. It will be very near the principal focus, and will be real, inverted and very small. Now carry the candle towards the mirror. The image moves out from the mirror and increases in size, but it remains real, inverted and smaller than the candle, until when the

candle reaches the centre of curvature, the image is there also and is of the same size.

Next, bring the candle nearer the mirror; the image moves farther and farther away, and is real, inverted and enlarged. When the candle reaches a certain place near the principal focus, the image will be seen on the opposite wall, inverted, and much enlarged; but when the candle is at the focus, the light is reflected from the mirror in parallel rays,—the image is at infinity.

When the candle is still nearer the mirror, *i.e.*, between the principal focus and the vertex, the reflected rays diverge from virtual foci behind the mirror (see Fig. 352). No real image is formed, one cannot receive it on a screen, but on looking into the mirror one sees a virtual, erect and magnified image.

If the candle is held before a convex mirror the image is always virtual, erect and smaller than the candle. A simple example of such a mirror is the outer surface of the bowl of a silver spoon.

361. To Draw the Image of an Object. Suppose PQ to be a small bright object placed before a concave mirror (Fig. 353).

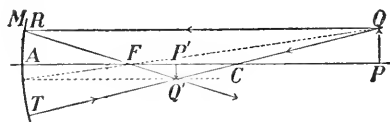

FIG. 353.—How to locate the image produced by a concave mirror.

The light which starts out from P will, after reflection, converge to the focus conjugate to P . Again QCT is a secondary axis, and rays starting out from Q

will converge to a point on QCT which is the conjugate focus of Q . P and Q are only two points of the object, but by similar reasoning we see that every point in PQ has a conjugate real image. We wish to draw the real image of PQ .

Now *all* the rays from Q after reflection pass through its image, and it is clear that we can locate the position of this image if we can draw any two rays which pass through it.

Draw a ray QR , parallel to PA ; this will, upon reflection, pass through F . Also, the ray QC will strike the mirror at right angles, and when reflected will return upon itself. The two reflected rays intersect at Q' which is therefore the image of Q . Drawing $Q'P'$ perpendicular to AC we obtain P' , the image of P , and $P'Q'$ is the image of PQ .

It is evident that the ray QF will, after reflection, return parallel to the axis AC , and will, of course, also pass through Q' .

By drawing any two of the three rays QR , QC , QF we can always find Q' , the image of Q . It should be observed, however, that all the other rays from Q as well as those drawn will after reflection pass through Q' .

It will be very useful to draw the image of an object in several positions. In Fig.

354 the object PQ is between A and F . By drawing QR , parallel to the axis, and QT , which passes through the centre of curvature, we obtain the image $P'Q'$. It is virtual and behind the mirror.

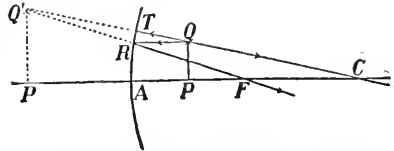

FIG. 354.—How to draw the image when the object is between the principal focus and the vertex.

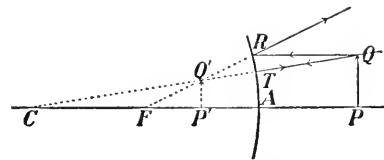

FIG. 355.—How to draw the image produced by a convex mirror.

In Fig. 355 the mirror is convex, and the image $P'Q'$ is virtual, erect, behind the mirror and smaller than PQ . It is always so in a convex mirror.

362. Relative Sizes of Image and Object.

Let PQ be an object and $P'Q'$ its image in a concave mirror (Fig. 356). The ray QA , which strikes the mirror at the vertex, is reflected along AQ' , and the angle $QAP = Q'AP'$.



FIG. 356.—The size of the object PQ is to that of the image $P'Q'$ as their distances from the mirror.

Also, the angle $APQ = \text{angle } AP'Q'$, each being a right angle, and hence the two triangles APQ , $AP'Q'$ are similar to each other.

The ratio of the length of the image to that of the object is called the *magnification*. Hence we have,

$$\text{Magnification} = \frac{P'Q'}{PQ} = \frac{AP'}{AP} = \frac{\text{distance of image from mirror}}{\text{distance of object from mirror}}.$$

In the case illustrated in the figure the magnification is less than one.

363. The Rays by which an Eye sees the Image. In § 361 a graphical method is given for locating the image of an object, but the actual rays by which an eye sees the image are usually not at all those shown in the figures.

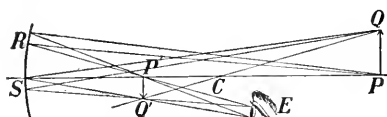

FIG. 357.—How the rays pass from the object to the eye. (Real image in concave mirror.)

In Figs. 357, 358, 359 are shown actual rays from points P and Q which reach the eye. In each figure the image is supposed to have been obtained by the graphical method. The image is real and inverted in Fig. 357, virtual and erect in the other two cases.

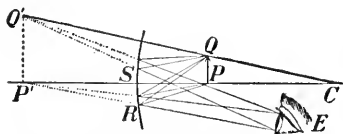

FIG. 358.—How the rays go from the object to the eye. (Virtual image in concave mirror.)

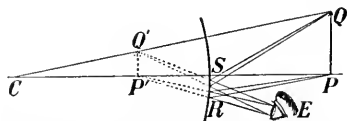

FIG. 359.—How the eye sees an object in a convex mirror. (Image always virtual.)

Now in each instance the light enters the eye as though it came from $P'Q'$. Join Q' to the outer edge of the pupil of the eye, forming thus a small cone with vertex at Q' . This cone meets the mirror at S , and it is clear that the light starts from Q , meets the mirror at S , is reflected there and then passes

through Q (really or virtually), and reaches the eye. In the figures are shown also rays starting out from P , the other end of the object. They meet the mirror at R , where they are reflected and then received by the eye. In the same way we can draw the rays which emanate from any point in the object.

It will be seen that for the eye in the position E , shown in the figures, the only part of the mirror which is used is that space from R to S . The rays which fall on other parts of the mirror pass above or below or to one side of the eye.

364. Parabolic Mirrors. In the case of a spherical mirror only those rays parallel to the axis which are incident near the vertex pass accurately through the principal focus; if the angular aperture is large the outer rays after reflection pass through points some distance from the focus (see Fig. 346). Conversely, if a source of light is placed at the principal focus, the rays after reflection will not all be accurately parallel to the axis, but the outer ones (Fig. 360) will converge inward, and later on after meeting will of course spread out. Hence at a great distance the light will be scattered and weakened.

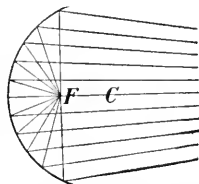

FIG. 360.—If a source of light is placed at the principal focus of a hemispherical mirror the outer rays converge and afterwards diverge again.

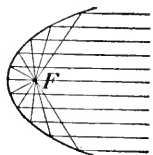

FIG. 361.—How a parabolic reflector sends out parallel rays.

Now a parabolic mirror overcomes this spreading of the rays. In Fig. 361 is shown a parabola. All rays which emanate from the focus, after reflection are parallel to the axis, no matter how great the aperture is. Parabolic mirrors are used in searchlights and in locomotive headlights. If a powerful source is used a beam can be sent out to great distances with

little loss of intensity.

QUESTIONS AND PROBLEMS

1. Distinguish between a real and a virtual image.
2. Prove that the focal length of a convex spherical mirror is equal to half its radius of curvature.
3. Show by diagrams that the image of a candle placed before a convex mirror can never be inverted.
4. Find the focus conjugate to each of the following points :
 - (a) the centre of curvature ;
 - (b) a point on the axis at an infinite distance ;
 - (c) the vertex ;
 - (d) the principal focus.

[By means of diagrams carefully drawn to scale solve the following three problems.]

5. An object 5 cm. high is placed 30 cm. from a concave mirror of radius 20 cm. Find the position and size of the image.
6. If the object is 8 cm. from the mirror, find the position and size of the image.
7. An object 6 cm. high is held 15 cm. in front of a convex mirror of radius 60 cm. Find the position, nature and size of the image.

CHAPTER XXXVII

REFRACTION

365. Meaning of Refraction. Suppose a ray of light PA , (Fig. 362), travelling through air, to arrive at the surface of another medium, water for instance. Some of the light will be reflected, and the remainder will enter the medium, but in doing so it will abruptly change its direction. This bending or *breaking* of its path is called *refraction*.

The angle i , between the incident ray and the normal, is the *angle of incidence*; and the angle r , between the refracted ray and the normal, is the *angle of refraction*.

In the figure, the angle r is smaller than i . This always happens when the second medium is *denser* than the first. The term *dense*, however, as used in optics is not synonymous with that used in mechanics (§ 17). Thus oil of turpentine (sp. gr., 0.87), or olive oil (sp. gr., 0.92), is less dense than water as defined in mechanics; and yet a ray of light when passing from air into oil of turpentine or olive oil is refracted more than it is when passing into water. We say that these substances are *optically denser* than water.

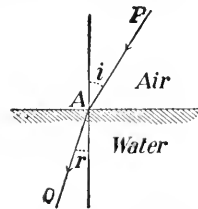

FIG. 362.—Illustrating refraction from air to water.

366. Experiments Illustrating Refraction. Place a coin PQ on the bottom of an opaque vessel (Fig. 363), and then move back until the coin is just hidden from the eye E by the side of the vessel. Let water be now poured into the vessel. The coin becomes visible again, appearing to be in the position $P'Q'$. The bottom of the vessel seems to have risen and the water looks shallower than it really is.

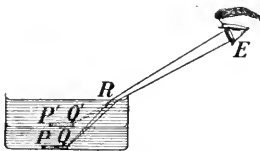

FIG. 363.—The bottom of the vessel appears raised up by refraction.

The bottom of the vessel seems to have risen and the water looks shallower than it really is.

The reason for this is readily understood from the figure. Rays proceed from Q to R , and on leaving the water are bent away from the normal, ultimately entering the eye as though they came from Q' . Similarly rays from P will be refracted at the surface, and will enter the eye as though they came from P' .

Another familiar illustration of refraction is the appearance of a stick—an oar, for example—when held obliquely in the water (Fig. 364). A pencil of light coming from any point on the stick, upon emergence from the water, is refracted downwards and enters the eye as though it came from a point nearer the surface of the water. Thus the part of the stick immersed in the water appears lifted up.



FIG. 364.—The stick appears broken at the surface of the water.

Thus the part of the stick immersed in the water appears lifted up.

367. Explanation of Refraction by Means of Waves. First, let us consider what might naturally happen when a regiment of soldiers passes from smooth ground to rough ploughed land. It is evident that the rate of marching over the rough land should be less than over the smooth. Let the rates be 3 and 4 miles an hour, respectively.

In the figure (Fig. 365) are shown the ranks of soldiers moving forward in the direction indicated by the arrows. The rank AB is just reaching the boundary between the smooth and the rough land, and the pace of the men at the end A is at once reduced. A short

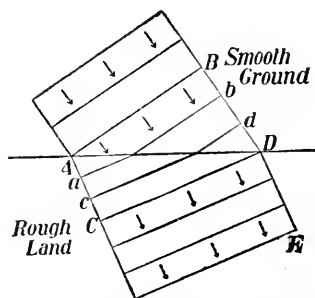

FIG. 365.—Illustrating how a change in direction of motion may be due to change in speed.

time later this rank reaches the position ab , part being on the rough and the rest still on the smooth ground. Next, it reaches the position cd , and then the whole rank reaches the position CD , entirely on the rough land. If now it proceeds in a direction at right angles to the rank, as shown by the arrows, it will move off in a direction quite different from the original one. The succeeding ranks, of course, follow in the same manner, and the new direction of motion is DE .

Now it is clear that the space BD of smooth ground is marched over in the same time as the space AC of rough land, and as the rates are 4 miles and 3 miles an hour, respectively, we have

$$\frac{BD}{AC} = \frac{4}{3}.$$

We have used ranks of soldiers in the illustration but waves behave very similarly. In Fig. 366 is reproduced a photograph of waves on the surface of water. These waves were produced by attaching a piece of thin glass to one prong of a tuning-fork and then vibrating it, just touching the surface. The waves move forward in the direction shown by the arrow, but on reaching the shallower water over a piece of glass lying on the bottom of the vessel, their speed is diminished (§§ 181, 183) and the wave-fronts swerve around, thus abruptly changing the direction of propagation.

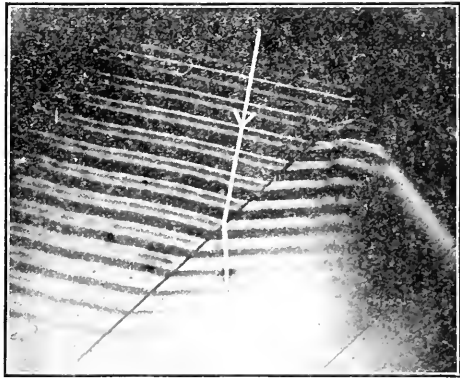

FIG. 366.—Plane waves on passing into shallower water are refracted as shown by the arrow. (Photograph by J. H. Vincent.)

368. **The Laws of Refraction.** In Fig. 367 GD is a ray

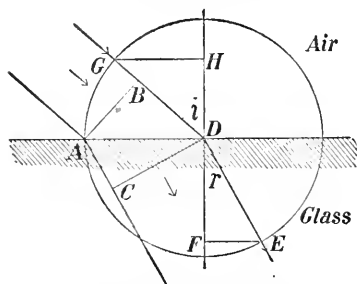

Fig. 367.—Diagram to explain the law of refraction. The length of GH is to that of FE as the velocity in air is to that in water.

incident on the surface of glass, DE is the corresponding refracted ray, and i and r are the angles of incidence and refraction, respectively. With centre D describe a circle, cutting the incident ray at G and the refracted ray at E . GH and EF are perpendiculars upon HF , the normal to the surface at the point D .

Then the angles i and r bear a definite relation to each other. Another ray, with a different i , will give rise to a refracted ray with a different r , but the relation between the two angles will be the same as before. We wish to discover what this relation is.

Let us consider the passage of the waves from the air to the glass. AB is a wave in the air just entering the glass, while CD is the position of the same wave when it has just got within the glass. Remember that the rays are perpendicular to the waves. Then from § 367 we have

$$\frac{BD}{AC} = \frac{\text{Velocity in air}}{\text{Velocity in glass}}.$$

Now compare the two triangles GHD and ABD . The angles GHD and ABD are equal, each being a right angle. Also, since GH is parallel to AD and GD meets them, the angle $HGD = \text{angle } ADB$. Hence also the angle $GDH = \text{angle } DAB$.

Also, the side $GD = \text{side } AD$. Thus the two triangles GHD , ABD are equal in every respect, the side GH being equal to side BD .

Again ADF and CDE are right angles, and if we take from each the angle CDF , which is common to both, we have angle $ADC =$ angle EDF . In the same way as before we can show that the two triangles ADC and EDF are equal in every respect, and that the side $AC =$ side EF .

$$\text{Hence } \frac{GH}{EF} = \frac{BD}{AC} = \frac{\text{Velocity in air}}{\text{Velocity in glass}}.$$

Now the ratio between the velocities is a numerical constant. It is usually denoted by the Greek letter μ (pronounced *mū*) and is called the *index of refraction* from the first medium into the second.

We find, then, that the angles of incidence and refraction are related to each other in the following way. *Describe a circle having as its centre the point where the incident ray strikes the surface of the second medium, and let this cut the incident and refracted rays. If now from these points of intersection perpendiculars be dropped upon the normal to the surface, then the ratio between the lengths of these perpendiculars is a numerical constant and is known as the index of refraction from the first medium into the second.*

This is the *first Law of Refraction*. It can be expressed much more simply by using the trigonometrical term called the *sine*, and is sometimes referred to as the *sine law*.*

The *second Law of Refraction* is:—*The incident ray, the refracted ray and the normal to the surface are in the same plane.*

369. Table of Indices of Refraction. The following table gives the values of the indices of refraction from air into various substances. If the first medium were a vacuum we would have the *absolute* index, but as the velocity of light in air differs very little from that in a vacuum the absolute indices differ very slightly from the values given here.

* Since $\sin i = \frac{GH}{GD}$, and $\sin r = \frac{EF}{ED}$, then $\frac{\sin i}{\sin r} = \frac{GH}{EF} = \mu$, the index of refraction.

It must be noted, however, that the indices are not the same for lights of all colours, those for blue light being somewhat greater than for red. The values given here are for yellow light, such as is obtained on burning sodium in a Bunsen or spirit flame.

INDICES OF REFRACTION

Crown-glass.....1.514 to 1.560	Hydrochloric acid (at 20° C.)...1.411
Flint-glass.....1.608 to 1.792	Nitric acid (at 20° C.).....1.402
Rock salt.....1.544	Sulphuric acid (at 20° C.)...1.437
Sylvine (potassium chloride)...1.490	Oil of turpentine (at 20° C.)...1.472
Fluor spar.....1.434	Ethyl alcohol (at 20° C.)...1.358
Diamond.....2.42 to 2.47	Carbon bisulphide (at 20° C.)...1.628
Canada balsam.....1.528	Water (at 20° C.)... ..1.334

370. Refraction Through a Plate. A plate is a portion of a medium bounded by two parallel planes. In Fig. 368, $PQRS$

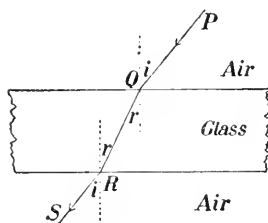

FIG. 368.—Showing the course of a ray of light through a glass plate.

shows the course of a ray of light through a plate of glass. It is refracted on entering the plate and again on emerging from it. Since the normals at Q and R are parallel, the angles made with these by QR are equal. Each of them is marked r . Then since the angles of incidence and refraction depend on the velocities of light in the two media, and if we send the light along SR it will pass through by the course RQP it is evident that the angle between SR and the normal at R is equal to that between PQ and the normal at Q . Each of these is marked i .

It is clear, then, that the incident ray PQ is parallel to the emergent ray RS , and therefore that the direction of the ray is not changed by passing through the plate, though it is laterally displaced by an amount depending on the thickness of the plate.

371. Vision Through a Plate. Let P be an object placed behind a glass plate and seen by an eye E (Fig. 369). The pencil of light will be refracted as shown in the figure, RE , TF being parallel to PQ , PS , respectively. The object appears to be at P' , nearer to the eye than P is.

This effect is well illustrated by laying a thick plate of glass over a printed page. It makes the print seem nearer the eye, and the plate appears thinner than it really is.

EXERCISE.—Draw the waves as they pass from P to the eye.

372. Total Reflection. Up to the present we have dealt mainly with the refraction of light from a medium such as air into one which is optically denser, such as water or glass. When we consider the light passing in the reverse direction we come upon a peculiar phenomenon.

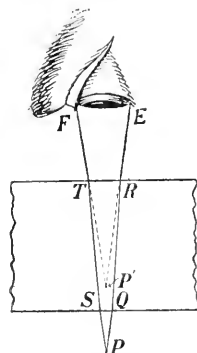

FIG. 369.—Showing why, when viewed through a glass plate, an object appears nearer.

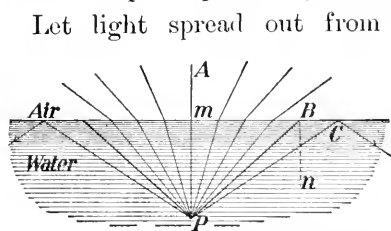

FIG. 370.— PB is the critical ray, and PBn (which is equal to BPm) is the critical angle for water and air.

Let light spread out from the point P , under water (Fig. 370). The ray Pm , which falls perpendicularly upon the surface, emerges as mA , in the same line. The rays on each side are refracted as shown in the figure, but the ray PB upon refraction just skims along the surface. What becomes of a ray such as PC ? It cannot emerge into the air, and so it is reflected back into the water. Moreover, since none of the light escapes into the air, it is *totally reflected*.

It is evident that all rays beyond PB are totally reflected. Now the angle of incidence of the ray PB is PBn , which

is equal to BPm . Hence if the angle of incidence of any ray is greater than PBn it will suffer *total reflection*. This angle is called the **CRITICAL ANGLE** which may be defined thus:—

If a ray is travelling in any medium in such a direction that the emergent ray just grazes the surface of the medium, the angle which it makes with the normal is called the critical angle.

373. Values of Critical Angles. It is evident that the denser or more refractive a medium is, the smaller is its critical angle, and consequently the greater will be the amount of light totally reflected. The diamond is very refractive, and its brilliant sparkling is largely due to the great amount of total reflection within it.

The values of the critical angles for some substances are approximately as follows:—

Water.....	$48\frac{1}{2}^\circ$	Crown-glass... $40\frac{1}{2}^\circ$	Carbon Bisulphide... 38°
Alcohol ...	$47\frac{1}{2}$	Flint-glass.... $36\frac{1}{2}$	Diamond..... $24\frac{1}{2}$

374. Total Reflection Prisms. Let ABC (Fig. 371) be a

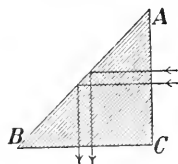

FIG. 371.—A total reflection prism.

glass prism with well-polished faces, the angles A and B each being 45° , and C therefore 90° . If light enters as shown in the figure, the angle of incidence on the face AB is 45° , which is greater than the critical angle. It will therefore be totally reflected and pass out as

indicated. Another form of total-reflecting prism is shown in Fig. 372 in which the angle B is 135° , A and C each $67\frac{1}{2}^\circ$. The course of the light is shown. Such arrangements are the most perfect reflectors known, and are frequently used in optical instruments.

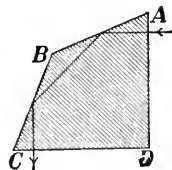

FIG. 372.—Another form of total-reflection prism.

This principle is also used in one form of the so-called 'Luxfer' prisms, two patterns of which are shown in Fig. 373. They are firmly fastened in iron frames which are let into the pavement. The sky-light enters from above, is reflected at the hypotenusal faces, and effectively illuminates the dark basement rooms.

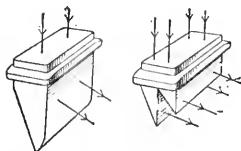

FIG. 373.—'Luxfer' prisms, useful in lighting basements.

375. Colladon's Fountain of Fire. Another beautiful illustration of total reflection is seen in the experiment known as Colladon's fountain.

A reservoir *A* (Fig. 374), about one foot in diameter and three feet high, is filled with water. Near the bottom is an opening *B*, about $\frac{1}{2}$ inch in diameter, from which the water spurts. A parallel beam of light from a lantern enters from behind, and by a lens *C* is converged to the opening from which the water escapes. The light enters the falling water, and being incident at angles greater than the critical from side to side. The light

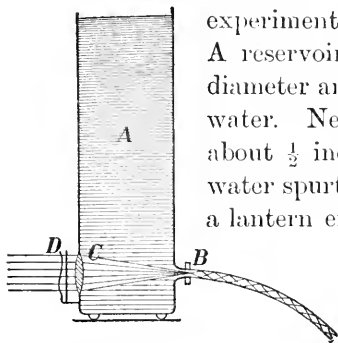

FIG. 374.—The 'fountain of fire.' The falling water seems to be on fire.

angle it is totally reflected imprisoned within the jet gives the water the appearance of liquid fire. Coloured glasses may be inserted at *D*, and beautify the effect.

The light enters the falling water, and being incident at angles greater than the critical from side to side. The light

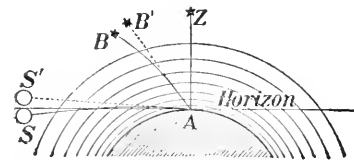

FIG. 375.—Showing how the atmosphere changes the apparent position of a heavenly body.

376. Atmospheric Refraction. As we ascend in the atmosphere its density gradually diminishes, and hence a ray of

light on passing from one layer to another must gradually change its direction. Let the observer be at *A* (Fig. 375), and let *AZ* be the

direction of the plumb-line. Z is then the observer's zenith. The plane through A , at right angles to AZ , is the horizon. A star at Z will appear in its proper direction since the light from it strikes the atmospheric strata perpendicularly and its direction is not altered. But the light from any other star, such as B , passes obliquely through the strata, and as it passes from the rarer to the denser, it will be curved downwards until, on arrival at A , it will appear to come from B' . Thus this star will seem to be nearer the zenith than it really is. For a similar reason the body S —the sun, say—though actually below the horizon, appears to be at S' , above it. In this way the period of daylight is made, in our latitude, from four to eight minutes longer than it would be if there were no atmosphere.

In all astronomical observations of the positions of the heavenly bodies allowance must be made for this change of direction due to refraction, but it may be remarked that the change is not nearly so great as is shown in the figure.

377. Refraction Through Prisms. A prism, as used in optics, is a wedge-shaped portion of a refracting substance, contained between two plane faces. The angle between the faces is called the *refracting angle*, and the line in which the faces meet is the *edge of the prism*.

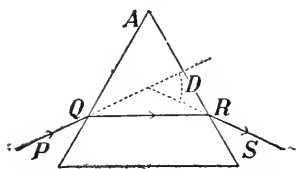

FIG. 376.—The path of light through a prism.

In figure 376 is shown a section of a prism the refracting angle A of which is 60° , and $PQRS$ is a ray of light passing through it. The angle D between the original direction PQ and the final direction RS is the *angle of deviation*. The deviation is always *away from the edge of the prism*.

By holding a prism in the path of a beam of light from the sun or from a projecting lantern one can easily exhibit the original and final directions of the light, and also the angle of deviation; and by rotating the

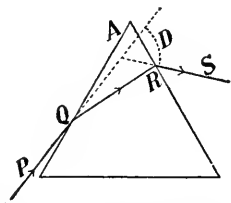

FIG. 377.—The ray is deviated more when it passes unsymmetrically through the prism.

prism it will be found that there is one position in which this angle has a minimum value. This is the case when the angles of incidence and emergence of the ray are equal, or the ray passes symmetrically through the prism (see Fig. 376). In any other position of the prism, such as that shown in Fig. 377, the angle of deviation is greater. When a prism is used in an optical instrument it is almost invariably placed in the position of minimum deviation.

QUESTIONS AND PROBLEMS

1. If the index of refraction from air to diamond is 2.47, what is the index from diamond to air?

2. The index of refraction from air to water is $\frac{4}{3}$, and from air to crown-glass is $\frac{3}{2}$. If the velocity of light in air is 186,000 miles per second find the velocity in water and in crown-glass; also the index of refraction from water to crown-glass.

3. Explain the wavy appearance seen above hot bricks or rocks.

4. A lighted candle is held in the beam of a projecting lantern. Explain the smoky appearance seen on the screen above the shadow of the candle.

5. In spearing fish one must strike lower than the apparent place of the fish. Draw a figure to explain why.

6. A strip of glass is laid over a line on a paper, (Fig. 378). When observed obliquely the line appears broken. Explain why this is so.

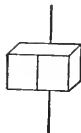

FIG. 378.—Why does the line appear broken?

7. The illumination of a room by daylight depends to a great extent on the amount of sky-light which can enter. Show why a plate of prism glass, having a section as shown in Fig. 379 placed in the upper portion of a window in a store on a narrow street is more effective in illuminating the store than ordinary plate-glass.

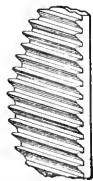

FIG. 379.—The plane face is on the outside.

8. Light passes from air into water, with an angle of incidence of 60° . By means of a carefully drawn figure and a protractor find the angle of refraction ($\mu = \frac{4}{3}$).

9. The critical angle of a substance is 41° . By means of a drawing determine the index of refraction.

CHAPTER XXXVIII

LENSES

378. Lenses. A lens is a portion of a transparent refracting medium bounded either by two curved surfaces or by one plane and one curved surface.

Almost without exception the medium used is glass and the curved surfaces are portions of spheres.

379. Kinds of Lenses. Lenses may be divided into two classes :

(a) Convex or converging lenses, which are thicker at the centre than at the edge.

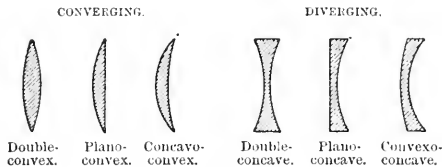

FIG. 380.—Lenses of different types.

(b) Concave or diverging lenses, which are thinner at the centre than at the edge.

In Fig. 380 are shown sections of different types

of lenses. The concavo-convex lens is sometimes called a converging meniscus, and the convexo-concave a diverging meniscus. A meniscus is a crescent-shaped body.

380. Principal Axis. The principal axis is the straight line joining the centres of the spherical surfaces bounding the lens, or if one surface is plane, it is the straight line drawn through the centre of the sphere and perpendicular to the plane surface.

381. Action of a Lens. Let a pencil of rays parallel to the principal axis fall upon a convex lens (Fig. 381). That ray which passes along the principal axis meets the surfaces at right angles, and hence passes through without suffering any deviation. But all other rays are bent from their original paths, the deviation being greater as we approach the edge.

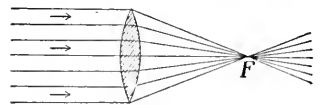

FIG. 381.—Parallel rays converged to the principal focus *F*.

The result is, the

rays are converged approximately to a point F on the principal axis. This point is called the *principal focus*, and in the case shown in the figure, since the rays actually pass through the point, it is a *real focus*.

A parallel beam, after passing through a concave lens (Fig. 382) is spread out in such a way that the rays *appear* to come from F , which is the *principal focus* and which, in this case, is evidently *virtual*.

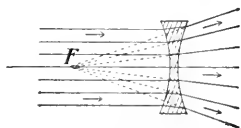

FIG. 382.—In a diverging lens the principal focus F is virtual.

382. Focal Length and Power of a Lens. The *focal length* of a lens is the distance from the principal focus to the lens, or more accurately, to the centre of the lens.

The more strongly converging or diverging a lens is, the shorter is its focal length and the greater is its *power*. Hence if f is the focal length and P the power of a lens, we have

$$P = \frac{1}{f}.$$

If a lens has a focal length of 1 metre its power is said to be 1 dioptré; if the focal length is $\frac{1}{2}$ metre the power is 2 dioptrés; and so on. Conversely, let us suppose a lens to have a power of 2.5 dioptrés, we must have

$$\text{Focal length, } f = \frac{1}{2.5} \text{ m.} = 40 \text{ cm.}$$

In prescribing spectacles the oculist usually states in dioptrés the powers of the lenses required.

383. Experimental Determination of Focal Length. By holding various lenses in sunlight or in a parallel beam from a projecting lantern, and shaking chalk-dust in the air, the nature of a lens can easily be observed.

If it is convex the principal focus is easily found by moving a paper, or a ground-glass screen, back and forth in the light until the brightest and smallest image is found. Then simply measure the distance from it to the lens.

As the focus of a concave lens is virtual the determination of its focal length is not so simple, but it may be found in the following way, which is similar to that used for a convex mirror (§ 357).

Make two slits m, p in a circular disc (a , Fig. 383) of paper

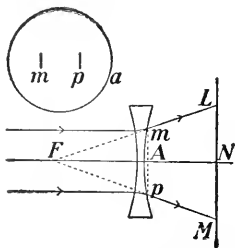

FIG. 383.—Finding the focal length of a concave lens.

just large enough to cover the lens. Moisten the paper, stick it on the lens, and allow parallel rays to fall on the lens. Now move a screen back and forth until the two bright spots L, M , made by the light passing through the slits, are just twice as far apart as the slits in the paper disc; that is, $LM = 2 mp$, and $LN = 2 mA$.

Then the distance of the screen from the lens is equal to the focal length.

From the figure it is evident that LFN and mFA are similar triangles, the former having just twice the linear dimensions of the latter. Hence $FN = 2 FA$, and therefore FA or $f = AN$.

This is not a very good method; a better one is described in the next section.*

384. Combinations of Lenses. Since the action of a convex lens is opposite to that of a concave lens, one converging while the other diverges the light, if we call one *positive* we should call the other *negative*. Let us take the convex lens to be positive.

Consider two converging lenses of focal lengths f_1, f_2 and powers P_1, P_2 . Then $P_1 = \frac{1}{f_1}$, $P_2 = \frac{1}{f_2}$. Let us put them

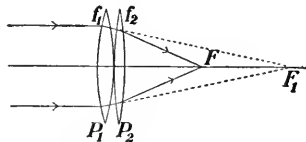

FIG. 384.—Combination of two converging lenses.

close together (Fig. 384). Then the convergency produced by the first is increased by the

* A third method is given in the *Laboratory Manual* designed to accompany this work.

second, and the power of the combination is $P_1 + P_2$. The focal length of the combination will be $\frac{1}{P_1 + P_2}$.

Next, consider the combined action of a convex and a concave lens (Fig. 385). Let the numerical values of the powers be P_1, P_2 . Then, since the concave lens diverges, while the convex converges, the power of the combination is $P_1 - P_2$,

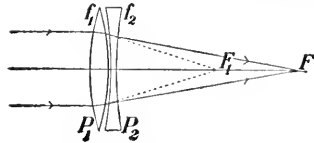

FIG. 385.—Combination of a converging and a diverging lens.

and the focal length of the combination is $\frac{1}{P_1 - P_2}$.

From this result we can deduce a method for finding the focal length of a concave lens.

First, find the focal length of a convex lens; let it be f_1 . Then place the concave lens beside the convex one and find the focal length of the combination; let it be f . Then if f_2 is the focal length of the concave lens, we have

$$\frac{1}{f_1} = P_1, \text{ the power of the convex lens,}$$

$$\frac{1}{f_2} = P_2, \text{ the power of the concave lens (numerically),}$$

$$\frac{1}{f} = P, \text{ the power of the combination.}$$

Now $P = P_1 - P_2$,

that is, $\frac{1}{f} = \frac{1}{f_1} - \frac{1}{f_2}$ and therefore $\frac{1}{f_2} = \frac{1}{f_1} - \frac{1}{f}$.

In order to use this method the convex lens should be considerably more powerful than the concave one.

For example, let the focal length of the convex lens be 20 cm., and that of the combination be 60 cm.

Then $\frac{1}{f_2} = \frac{1}{20} - \frac{1}{60} = \frac{1}{30}$ and $f_2 = 30$ cm.

385. Conjugate Foci. (a) **Converging Lens.** If the light



FIG. 386.— P and P' are conjugate foci.

is moving parallel to the principal axis and falls upon a convex lens it is converged to the principal focus (Fig. 381). Next, let it emanate

from a point P , on the principal axis (Fig. 386). The lens now converges it to the point P' , also on the principal axis and farther from the lens than F .

Again, let us consider the direction of the light as reversed, that is, let it start from P' and pass through the lens. It is evident that it will now converge to P . Hence P and P' are two points such that light coming from one is converged by the lens to the other. Such pairs of points are called *conjugate foci*, as in the case of curved mirrors.

As P is taken nearer the lens its conjugate focus P' moves farther from it. If P is at F , the principal focus, the rays leave the lens parallel to the principal axis (Fig. 387), and when P is closer to the lens than F (Fig. 388) the lens

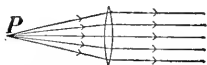

FIG. 387.—Light emanating from the principal focus comes from the lens in parallel rays.

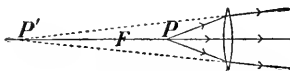

FIG. 388.—Here P' , the focus conjugate to P is virtual.

converges the rays somewhat and they move off apparently from P' which in this case is a virtual focus.

(b) **Diverging Lens.** In the case of a diverging lens, if the incident light is parallel to the principal axis it leaves the lens diverging from the principal focus F (Fig. 382). Let the light

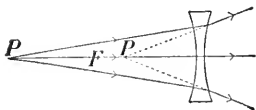

FIG. 389.— P' is conjugate to P .

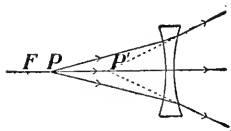

FIG. 390.—Conjugate foci in a diverging lens.

start from the point P (Figs. 389, 390). The light is made still more divergent by the lens, and on emergence from it

appears to move off from P' which is conjugate to P and is virtual.

386. Explanation by Means of Waves. The theory that light consists of waves easily accounts for the action of lenses. Let us suppose that waves of light travelling through the air pass through a glass lens.

In Fig. 391 plane waves (parallel rays) fall on the lens. Now their velocity in glass is only $\frac{2}{3}$ that in air, and that part of the waves which passes through the central part of the convex lens will be delayed behind that which traverses the lens near its edge, and the result is, the waves are concave on emerging from the lens. They continue moving onward, continually contracting, until they pass through F , the principal focus, and then they enlarge.

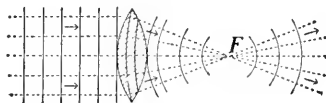

Fig. 391.—Plane waves made spherical by a converging lens.

In Fig. 392 spherical waves spread out from P . On traversing the central portions they are held back by the thicker part of the

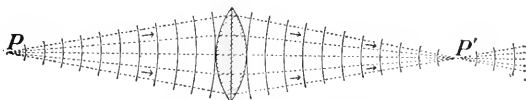

Fig. 392.—Waves expanding from P are changed by the lens into contracting spherical waves.

lens, and on emerging they are concave, but they do not converge as rapidly as in the first case.

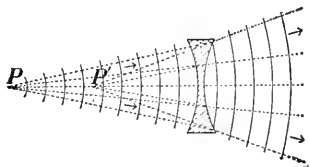

Fig. 393.—Waves going out from P are made more curved by the lens, and appear to have P' as their centre.

In Fig. 393 is shown the effect of a concave lens. The outer portions of the lens being thicker than the central, retard the waves most, with the result that the convexity of the waves is increased, so that they move off having P' as their centre.

These results are further illustrated in a striking and beautiful manner by using an *air lens* in an 'atmosphere' of water. Such a lens can be constructed without difficulty by cementing two 'watch-glasses' into a turned wooden

or ebonite rim. In Fig. 394 is shown a double-concave lens immersed in water contained in a tank with plate-glass sides.

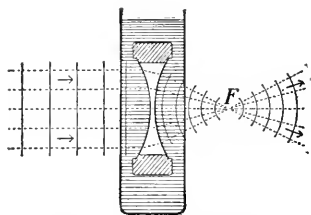

FIG. 394.—A concave air lens in an atmosphere of water converges the light.

Plane waves from a lantern pass into the water, and on entering the lens the outer portions, since they travel in the air, rush forward ahead of the central part, thus rendering the waves concave and converging to a focus F . Thus a concave air lens in water is converging; in a similar way it can be shown that a convex air lens in a water atmosphere is diverging.

387. Experimental Illustrations. The relative positions of object and image can be easily exhibited experimentally, in a way similar to that used in the case of curved mirrors (§ 360).

First place a convex lens on the table, and as far from it as possible set a candle. Then by moving a sheet of paper back and forth behind the lens the small bright image is found. Examine it closely and you will see that it is inverted.

Now bring the candle slowly up towards the lens, at the same time moving the screen so as to keep the image on it. We find that the image gradually moves away from the lens, continually increasing in size as it does so.

At a certain place the image is of the same size as the object, but inverted. By measurement we find that each is twice the focal length from the lens.

Bring the candle still nearer to the lens. The image retreats, and when the candle is at the principal focus the image is at an infinite distance,—the rays leave the lens parallel to the principal axis.

Finally, hold the candle between the principal focus and the lens; no real image is formed (Fig. 388).

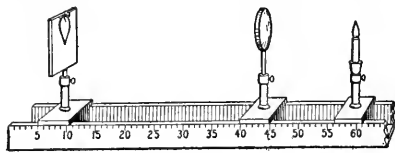

FIG. 395.—An optical bench, for studying object and image.

For making measurements of the distances of object and image from the lens the most convenient arrangement is an optical bench, one form of which is shown in Fig. 395.

On using a concave lens we cannot obtain a real image of the object. If we view the candle through a concave lens we always see an erect image smaller than the candle, apparently between the lens and the candle. It is always virtual (see Figs. 389, 390).

388. How to Locate the Image. Let PQ (Fig. 396) be an object placed before a convex lens A . The position of the image can be very easily located in the following way.

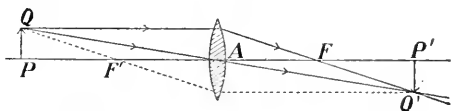

FIG. 396.—Showing how to locate the image of PQ .

From Q draw a ray parallel to the principal axis; on emerging from the lens it will pass through F' , the principal focus. Again, the ray QA which passes through the centre of the lens is not changed in direction. Let it meet the former ray in Q' . Then Q' will be the point on the image corresponding to Q on the object. Draw $Q'P'$, perpendicular to the principal axis. This is the image of QP . Also, the ray QF'' , which passes through the principal focus on the nearer side, will, after passing through the lens, proceed parallel to the principal axis and will pass through Q' .

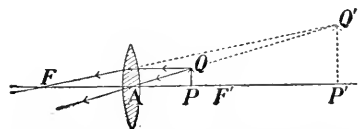

FIG. 397.—How to draw the image when the object is between the lens and the principal focus.

The position of Q' can always be located by drawing two of these three rays.

In Fig. 397 is shown the case in which the object is between the lens and the principal focus. The rays drawn parallel to the axis and through the centre of the lens do not meet after passing

through the lens, but on producing them backwards they intersect at Q' . $Q'P'$ is the image of QP . It is virtual, erect and larger than the object.

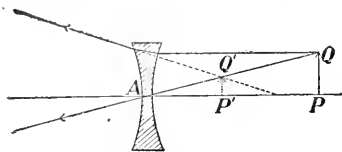

FIG. 398.—How to draw the image in a concave lens.

For a concave lens we have the construction shown in Fig. 398. The image is virtual,

erect and smaller than the object.

389. Magnification. On examining Figs. 396–8, it will be seen that the triangles QAP , $Q'AP'$ are similar, and as before (§ 362) calling the ratio of the length of the image to that of the object the *magnification*, we have

$$\text{Magnification} = \frac{P'Q'}{PQ} = \frac{AP'}{AP} = \frac{\text{distance of image from lens}}{\text{distance of object from lens}}$$

390. Vision Through a Lens. In § 388 is explained a method of finding the position of an image produced by a lens but it should be remembered that this is simply a geometrical construction and that the rays shown there are usually not those by which the eye sees the image. Let us draw the rays which actually enter the eye.

In Fig. 399 $P'Q'$ is the (real) image of PQ , and E is the eye.

From Q' draw rays to fill the pupil of the eye. Then produce these backwards

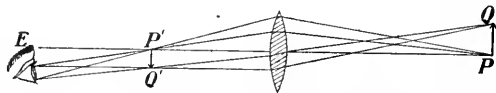

FIG. 399.—Showing the rays by which the eye sees the image of an object.

to meet the lens and finally join them to Q . Thus we obtain the pencil by which Q is seen. In the same way we trace the light from P to the eye.

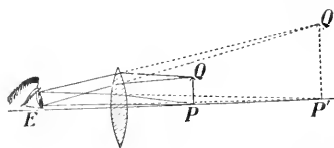

FIG. 400.—The rays reach the eye by the paths shown.

In Fig. 400 $P'Q'$ is virtual, but the construction is the same as before. The student should draw other cases. The method is similar to that

explained for curved mirrors (§ 363).

CHAPTER XXXIX

DISPERSION, COLOUR, THE SPECTRUM, SPECTRUM ANALYSIS

391. Another Refraction Phenomenon. In Chap. XXXVII we have explained various phenomena of refraction, but there is one,—a very important one, too,—which we have not discussed at all. When white light passes obliquely from one medium into another of different refractive power, the light is found, in the second medium, to be split up into parts which are of different colours. This separation or *spreading out* of the constituents of a beam of light is called *dispersion*.

392. Newton's Experiment. Newton was the first to examine in a really scientific way the dispersion produced by a prism, and Fig. 401 illustrates his method of experimenting. He admitted sunlight through a hole in a window-shutter, and placed a glass prism in the path of the beam. On the opposite wall, $18\frac{1}{2}$ feet from the prism, he observed an oblong image, which had parallel sides and semi-circular ends, $2\frac{1}{2}$ inches wide and $10\frac{1}{4}$ inches long. That end of the image farthest from the original direction of the light was violet, the other end red.

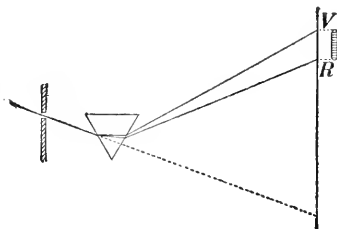

FIG. 401.—Light enters through a hole in the window-shutter, passes through a prism and is received on the opposite wall.

This image Newton called the *spectrum*. On careful inspection he thought he could recognize *seven* distinct colours, which he named in order:—red, orange, yellow, green, blue, indigo, violet.

It should be noted, however, that there are not seven separate coloured bands with definitely marked dividing lines between them. The adjoining colours blend into each other, and it is impossible to say where one ends and the next begins. Very often indigo is omitted from the list of colours, as not being distinct from blue and violet.

From Newton's experiment we conclude:—

(1) That white light is not simple but composite, that it includes constituents of many colours.

(2) That these colours may be separated by passing the light through a prism.

(3) That lights which differ in colour differ also in degrees of refrangibility, violet being refracted most and red least.

It will now be understood why, in § 369, when giving the indices of refraction for various substances, it was necessary to specify to what colour the values referred.

393. A Pure Spectrum. It is often inconvenient to use sunlight for this experiment, and we may substitute for it the light from a projecting lantern.

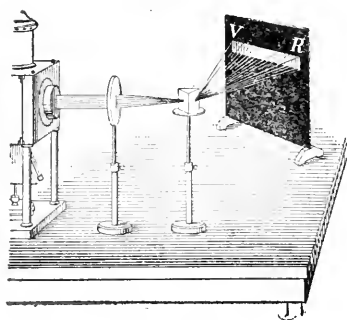

FIG. 402.—Showing how to produce a pure spectrum.

A suitable arrangement is illustrated in Fig. 402. The light emerges from a narrow vertical slit in the nozzle of the lantern, and then passes through a converging lens, so placed that an image of the slit is produced as far away

as is the screen on which we wish to have the spectrum. Then a prism is placed in the path, and the spectrum appears on the screen.

The spectrum thus produced is *purer* than that obtained by Newton's simple method. Imagine the round hole used by Newton to be divided up into narrow strips parallel to the edge of the prism. Each strip will produce a spectrum of its own, but the successive spectra overlap, and hence the colour produced at any place is a mixture of adjacent spectral colours. Thus to obtain a pure spectrum, that is, one in which the colours are not mixtures of several colours, we require a narrow slit as our source. In addition, the lens must be used to focus the image of the slit on the screen, and the prism should be placed in the position of minimum deviation (§ 377).

394. Colours of Natural Objects. Let us produce the spectrum on the screen by means of the projecting lamp; we obtain all the colours as in *a*,

Fig. 403. Next place over the slit a red glass; the beam now transmitted consists mainly of red light, a little orange perhaps being present (*b*, Fig. 403).

The glass does not owe its colour to the introduction of anything into the spectrum which did not previously exist there, but simply because it absorbs or suppresses all but the red and a little orange. We obtain similar results with green, yellow, or other colours. It is to be noted, however, that scarcely any of the transmitted colours are pure. Several colours will usually be found present, the predominating one giving its colour to the glass.

Next hold a bit of red paper or ribbon in different portions of the spectrum. In the red it appears of its natural colour, but in every other portion it looks black. This tells us that a *red* object appears red because it absorbs the light of all other colours, reflecting or scattering only the red. In order to produce this absorption and scattering, however, the light must penetrate some distance into the object; it is not a simple surface effect. Similarly with green, or blue, or violet



FIG. 403.—A red glass transmits only red and some orange.

ribbons, but, as in the case of the coloured glass, the colours will usually be far from pure. Thus a blue ribbon will ordinarily reflect some of the violet and the green, though it will probably appear quite black in the red light.

Let us think for a moment what happens when sunlight falls on various natural objects. The rose and the poppy appear red because they reflect mainly red light, absorbing the more refrangible colours of the spectrum. Leaves and grass appear green because they contain a green colouring matter (chlorophyll) which is able largely to absorb the red, blue and violet, the sum of the remainder being a somewhat yellowish green. A lily appears white because it reflects all the component colours of white light. When illuminated by red light it appears red; by blue, blue.

A striking way to exhibit this absorption effect is by using a strong sodium flame in a well-darkened room. This light is of a pure yellow, and bodies of all other colours appear black. The flesh tints are entirely absent from the face and hands, which, on this account, present a ghastly appearance.

We see, then, that the colour which a body exhibits depends not only on the nature of the body itself, but also upon the nature of the light by which it is seen.

At sunrise and sunset the sun and the bright clouds near it take on gorgeous red and golden tints. These are due chiefly to absorption. At such times the sun's rays, in order to reach us, have to traverse a greater thickness of the earth's atmosphere than they do when the sun is overhead (compare Fig. 375), and the shorter light-waves, which form the blue end of the spectrum, are more absorbed than the red and yellow, which tints therefore predominate.

In § 195 reference was made to the stupendous volcanic eruption at Krakatoa in 1883. For many weeks after this the atmosphere was filled with dust, and sunsets of extraordinary magnificence were observed all over the world.

Somewhat similar absorption effects are produced in the neighbourhood of great forest fires, the ashes from which are conveyed by winds over considerable areas.

395. Recomposition of White Light. We have considered the decomposition of white light into its constituents; let us now explain several ways of performing the reverse operation of recombining the various spectrum colours in order to obtain white light.

(1) If two similar prisms be placed as shown in Fig. 404, the second prism simply reverses the action of the first and restores white light. The two prisms, indeed, act like a thick plate (§ 370).

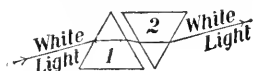

FIG. 404.—The second prism counteracts the first.

(2) By means of a large convex lens, preferably a cylindrical one (a tall beaker filled with water answers well), the light dispersed by the prism may be converged and united again. The image, when properly focussed, will be white.

(3) Next, we may allow the dispersed light to fall upon several small plane mirrors, and then by adjusting these properly the various colours may be reflected to one place on the screen, which then appears white (Fig. 405).

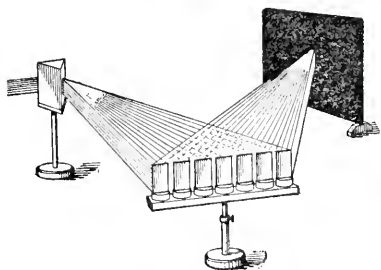

FIG. 405.—The light after passing through the prism falls on several small mirrors which reflect it to one place on the screen.

(German mirror), say 2 feet long by 4 inches wide. First, hold this in the path of the dispersed light so as to reflect it

upon the opposite wall of the room. Then, by taking hold of the two ends of the strip, gently bend it until it becomes concave enough to converge the various coloured rays to a spot on the screen.

(4) In all the above cases the coloured lights are mixed together outside the eye. Each colour gives rise to a colour-sensation, and a method will now be explained whereby the various colour-sensations are combined within the eye. The most convenient method is by means of Newton's disc, which consists of a circular disc of cardboard on which are pasted sectors of coloured paper, the tints and sizes of the sectors being chosen so as to correspond as nearly as possible to the coloured bands of the spectrum.

Now put the disc on a whirling machine (Fig. 406) and set it in rapid rotation. It appears white, or whitish-gray. This is explained as follows:—

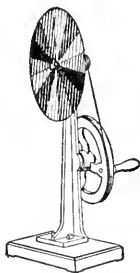

FIG. 406.—Newton's disc on a rotating machine.

Luminous impressions on the retina do not vanish instantly when the source which excites the sensation is removed. The average duration of the impression is $\frac{1}{10}$ second, but it varies with different people and with the intensity of the impression. If one looks closely at an incandescent electric lamp for some time, and then closes his eyes, the impression will stay for some time, perhaps a minute. With an intense light it will last longer still.

If a live coal on the end of a stick is whirled about, it appears as a luminous circle; and the bright streak in the sky produced by a "shooting star" or by a rising rocket is due to this persistence of luminous impressions. In the same way, we cannot detect the individual spokes of a rapidly rotating wheel, but if illuminated by an electric spark we see them

distinctly. The duration of the spark is so short that the wheel does not move appreciably while it is illuminated.

In the familiar "moving pictures" the intervals between the successive pictures are about $\frac{1}{10}$ second, and the continuity of the motion is perfect.

If then the disc is rotated with sufficient rapidity the impression produced by one colour does not vanish before those produced by other colours are received on the same portion of the retina. In this way the impressions from all colours are present on the retina at the same time, and they make the disc appear of a uniform whitish-gray. This gray is a mixture of white and black, no colour being present, and the stronger the light falling on the disc the more nearly does it approach pure white.

396. Complementary Colours. Let us cut out of black cardboard a disc of the shape shown in Fig. 407, and fasten it on the axis of the whirling machine over the Newton's disc so that it just hides the red sectors. On rotating, the colours which are exposed produce a bluish-green. It is evident, then, that this colour and red when added together will give white. *Any two colours which by their union produce white light are called complementary.* From the way it was produced we know that this blue-green is not a pure colour, but the eye cannot distinguish it from a blue-green of the same tint chosen from a pure spectrum. By covering over other colours of the Newton's disc we can obtain other complementary pairs. A few of these pairs are given in the following table:—



FIG. 407.—Disc to put over Newton's disc to cut out any desired colour.

COMPLEMENTARY COLOURS

Red	Orange	Yellow	Green-yellow	Green
Green-blue	Bluish-green	Blue	Violet	Purple

In Fig. 408 these are arranged about a circle. Note that the complement of green is purple, which is not a simple spectral colour but a compound of red and violet.

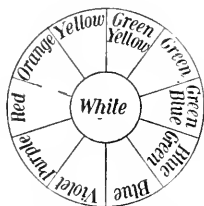

FIG. 408.—The radially opposite colours are complementary.

pigment. Wherein is the difference? It arises from the fact that the mixing of coloured lights is a true *addition* of the separate effects, while in mixing pigments there is a *subtraction* or *absorption* of the constituents of the light which falls on them.

Ordinarily blue paint absorbs the red and the yellow from the incident light, reflecting the blue and some of the adjacent colours, namely green and violet. Yellow paint absorbs all but the yellow and some red and green. Hence when yellow and blue paints are mixed the only coloured constituent of the incident light which is not absorbed is green, and so the resulting effect is green.

Thus mixing pigments and mixing colours are processes entirely unlike in nature, and we should not be surprised if the results produced are quite dissimilar. Indeed the result obtained on mixing two pigments does not even suggest what will happen when two coloured lights of the same name are added together.

398. Achromatic Lenses. The focal length of a lens depends on the index of refraction of the material from which the lens is made, and as the index varies with the wave-length, or the colour, the focal length is not the same for all colours.

As the violet rays are refracted more than the red, the focal length for violet is shorter than for red. Thus, in Fig. 410, the

397. Mixture of Pigments. On rotating a disc with yellow and blue sectors,* as indicated in Fig. 409, we obtain white. On the other hand, if we mix together yellow and blue pigments we get a green

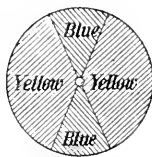

FIG. 409.—A complementary colour disc.

* We might use a single sector of blue and one of yellow but the speed of rotation would then have to be doubled.

violet rays come to a focus at V while the red converge to R , the foci for the other colours lying between V and R . A screen held at A will show a circular patch of light edged with red, while if at B it will show a patch edged with violet. This inability to converge all the constituents of a beam of white light to a single point is a serious defect in single lenses, and is known as *chromatic aberration*.

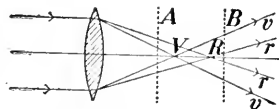

FIG. 410.—The foci for violet and red rays are quite separated.

Thus there is no single point to which all the light converges, and in determining the principal focus it is usual to find the focus for the yellow rays, which are brightest.

Newton endeavoured to devise a combination of lenses which would be free from chromatic aberration, but he failed. He concluded that if a second lens counteracted the dispersion of the first it would also counteract its refraction or bending of the rays, in which case the two lenses would not act as a lens any longer. In this he was mistaken, however. In 1757 Dollond, a London optician, discovered a combination of lenses which was

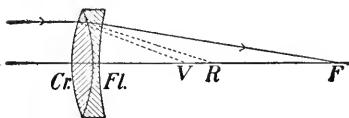

FIG. 411.—An achromatic combination of lenses.

free from chromatic aberration. The arrangement is shown in Fig. 411. Flint-glass is more dispersive than crown-glass, and a crown-glass converging lens is combined with a flint-glass diverging lens of less power. The crown-glass lens would converge the red rays to R and the violet to V , while the flint-glass then diverges both of these so that they come together at F .

Such compound lenses are said to be *achromatic*. They are used in the construction of all telescopes and microscopes. In the modern microscope objective, however, the simple combination of two lenses does not suffice to give an image perfectly free from all defects, and many other combinations are used. In some high-power objectives there are as many as ten single lenses, made of various kinds of glass and having surfaces of various curvatures. (Fig. 412.)

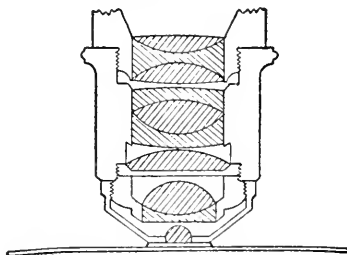

FIG. 412.—A section of an apochromatic microscope objective made by Zeiss.

399. The Rainbow. In the rainbow we have a solar spectrum on a grand scale. It is produced through the refraction and dispersion of sunlight by rain-drops.

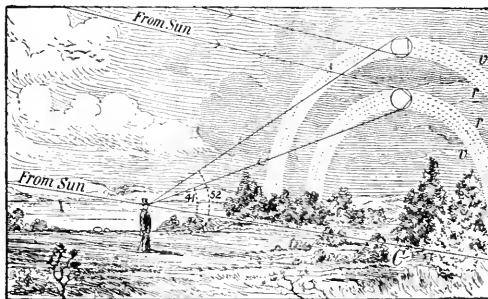

FIG. 413.—Illustrating how the rainbow is produced.

In order to see it the observer must look towards falling rain, with the sun behind him and not more than 42° above the horizon. Frequently two bows are visible, the *primary* bow and the *secondary* bow. The former is violet on the inside and red on the outside; while in the secondary bow which is larger and fainter, the order of the colours is reversed. Both bows are arcs of circles having a common centre (C , Fig. 413), which is on the line which passes through the sun and the eye of the observer.

A line drawn from the eye to the primary bow makes an angle of about 41° with this line, while a line to the secondary bow makes an angle of about 52° with it.

In Fig. 413 is shown the relative positions of the sun, the rain-

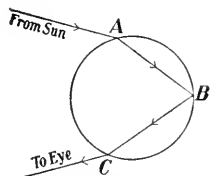

FIG. 414.—Showing how the light passes to form the primary bow.

drops and the observer, while in Figs. 414, 415 is shown the manner in which the sun's rays pass through the drops.

For the primary bow the rays are refracted into the drop at A (Fig. 414), reflected at B , and refracted out at C . For the secondary, the light enters at A (Fig. 415), is reflected first at B and then at D and is refracted out at C .*

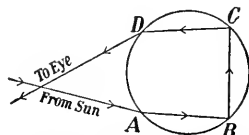

FIG. 415.—Showing how the light passes to form the secondary (outer) bow.

400. The Spectroscope. In § 393 a method was explained for projecting a pure spectrum upon the screen. This can be done when the source is very bright (such as the sun, the arc-lamp or the lime-light), but for a faint light the method is not practicable. It is necessary to receive the light, after disper-

* For further information more advanced works must be consulted.

sion, directly into the eye, which is marvellously sensitive, or on a photographic plate.

The simplest method of all is illustrated in Fig. 416, in which S is a slit $\frac{1}{10}$ or $\frac{1}{20}$ inch wide in a sheet of metal, and behind it is placed L the source of light to be examined. This may be a Bunsen or alcohol flame (which are themselves colourless), in which substances are burnt, or any other convenient source. The experimenter then stands at a distance of 10 feet or more from the slit and observes it through a prism which is held near the eye. The spectrum will appear directly ahead, as at VR . In this arrangement the light comes from the slit to the prism in a narrow parallel beam, and the lens of the eye focusses it upon the retina.

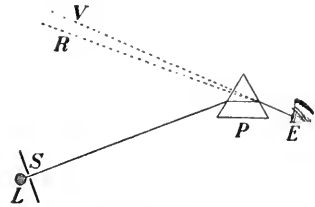

FIG. 416.—A simple method of producing a pure spectrum. L is the light source behind a slit S , and SP is about 10 feet.

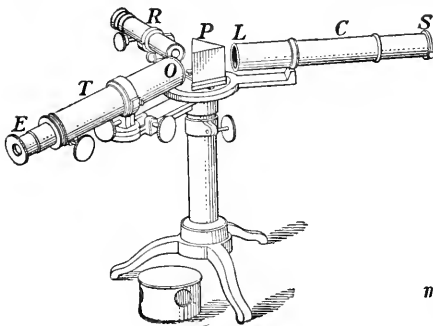

FIG. 417.—A single-prism spectroscope.

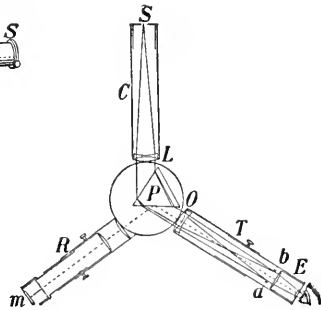

FIG. 418.—A horizontal section of a single-prism spectroscope.

If a small telescope is placed between the prism and the eye, and focussed on the slit, the spectrum will be seen to better advantage.

But the most satisfactory method is to use a spectroscope, which is an instrument especially designed to examine the spectra of various sources. A simple form is illustrated in Fig. 417 and a sectional plan is given in Fig. 418. The tube

C , known as the collimator, has a slit S at one end and a lens L at the other. The slit is at the focus of the lens, so that the light emerging from the tube is a parallel beam. It then passes through the prism P , and is received in a telescope T , the lens O of which focusses the spectrum in the plane ab . It is then viewed by the eye-piece E .

The light to be examined is placed before S . Usually a third tube R , is added. This has a small transparent scale m at one end and a lens at the other. A lamp is placed before the scale, and the light passes through the tube, is reflected from a face of the prism and then enters the telescope, an image of the scale being produced at ab , above the spectrum. By referring to this scale any peculiarities of the spectrum of the light which is under examination can be localized or identified.

401. Direct-vision Spectroscope. By using three prisms, one of flint and two of crown-glass (Fig. 419), it is possible to

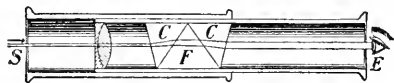

FIG. 419.—A direct-vision spectroscope.

get rid of the deviation of the middle rays of the spectrum while still dispersing the colours. Such a combination is used in pocket

spectroscopes. The slit S admits the light and a convex lens converts the light into a parallel beam, which, after traversing the prisms, is seen by the eye at E . One tube can be slid over the other in order to focus the slit for the eye.

402. Kinds of Spectra. By means of our spectroscope let us investigate the nature of the spectra given by various sources of light.

First, take an electric light. It gives a continuous coloured band, extending from red to violet without a break. A gas-flame, an oil lamp or the lime-light gives a precisely similar spectrum.

Next, place a colourless Bunsen or alcohol flame before the slit, and in it burn some salt of sodium, (chloride or carbonate of sodium, for instance). The flame is now bright yellow, and the spectrum shown in the spectroscope is a single bright yellow line.* Using

* There are really *two* narrow lines very close together, which can be seen even with some pocket spectroscopes.

strontium nitrate the flame is crimson, and the spectrum consists of several red and orange lines and a blue one. The salts of barium, potassium and other metals give similar results, each however with its own particular arrangement of lines.

Again, place an electric lamp before the slit of the instrument, and then between it and the slit place a vessel with plate-glass sides containing a dilute solution of permanganate of potash. The spectrum is now continuous except that it is crossed by fine dark bands in the green. Using a dilute solution of human blood we get a continuous spectrum except for well-marked dark bands in the yellow and the green.

After long experimenting on light sources of various kinds we have been led to divide spectra into three classes:—

(1) **Continuous Spectra.** In these there is present light of every shade of colour from the red to the violet, with no gaps whatever in the band. Such spectra are obtained from all white-hot solids or liquids (molten metals for instance), and from gases under great pressure. The flame of gas or of a candle gives a continuous spectrum. This is due to the white-hot particles of carbon present. These may be collected by holding a piece of cold glass or porcelain over the flame.

(2) **Discontinuous or Bright-line Spectra.** These consist of bright lines on a dark background, and are given by glowing vapours and by gases under smaller pressure. The gas is generally enclosed in a glass tube such as is shown in Fig. 420, the pressure being a few millimetres of mercury, and the tube being rendered luminous by an induction coil (§ 535).

(3) **Absorption or Dark-line Spectra.** These are just the reverse of those in class 2. Usually all the colours are present but the continuity is broken by dark bands, sometimes narrow and well-defined, at other times wide and diffuse. The background is bright and the distinctive lines or bands across it are dark. Such spectra are given by the sun, the moon, the planets and by the stars.

403. Spectrum Analysis. Now each element, when in the form of a vapour, has its own peculiar spectrum, the arrangement of the bright lines in no two spectra being exactly alike. Hence by means of its spectrum the presence of a substance can be recognized. If several elements are present their spectra will all be shown and the elements can be thus recognized. This method of detecting



FIG. 420.—A tube for holding a gas to be examined by the spectroscope.

the presence of an element is known as *spectrum analysis*. It is an extremely sensitive method of analysis. Thus the presence of $\frac{1}{2000}$ mg. of barium, of $\frac{1}{800000}$ mg. of lithium, or of $\frac{1}{140000000}$ mg. of sodium is sufficient to show the lines characteristic of these elements. This method enables the chemist to apply a delicate test for the presence of a substance, and by it the astronomer has wonderfully extended our knowledge of the nature and the motions of the heavenly bodies.

404. The Solar Spectrum. In 1802, Wollaston, a London physician, while examining the sunlight by means of a prism, observed *four* dark lines across its spectrum. Some years later, Fraunhofer, a scientific optician of Munich, using a prism and telescope* (the second method described in §400), discovered not

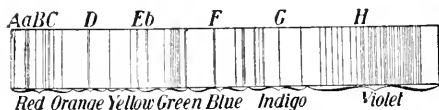

FIG. 421.—Showing some of the 'dark lines' in the spectrum of sunlight.

(Fig. 421); but they are often called *Fraunhofer's lines*. They always have the same position in the spectrum, and are convenient 'landmarks' from which to make measurements.

Thus we see that the solar spectrum is an absorption spectrum, the dark lines being numerous and fine. Photographs have revealed the existence of at least 20,000 of these lines.

405. The Meaning of the Dark Lines. It was long felt that the interpretation of these dark lines was a matter of great importance, and the mystery was at last solved in 1859 by Kirchhoff.

In the orange-yellow of the solar spectrum is a prominent dark line,—or rather a pair of lines very close together,—named *D* by Fraunhofer. Now sodium vapour shows two fine bright yellow lines, which, by reference to the scale of our spectroscope, we see coincide in position with the solar *D* dark lines. Indeed, by means of a small total-reflection prism with which the slit-end of the spectroscope is usually supplied, it is possible to observe the spectrum of the sun and of sodium vapour at the same time, one spectrum being above the other, and by this arrangement the coincidence in position is seen to be exact. From this result we would at once suspect that the *D* lines in the sun must have some connection with sodium.

* Fraunhofer (1787-1826) constructed his own prism and telescope, and engraved his own spectrum maps when he published his investigations in 1815.

Just what this connection is may be shown in the following way. First place before the slit of the spectroscope an intense source of light, such as the arc or the lime-light. This gives a continuous spectrum with no dark lines at all. Now, while observing this, introduce between the intense source and the slit a Bunsen flame full of sodium vapour. This addition of yellow light we would naturally expect to make the yellow portion of our spectrum more intense, but that is not what happens at all! On the contrary, we see two dark absorption lines in precisely the position where the bright sodium lines are produced. By screening off the intense source the bright sodium lines are seen.

A simple method of performing this experiment is shown in Fig. 422. Here the origin of the light is an arc lamp. In order to obtain sodium vapour one end of a wire is made into a ring, about which asbestos wick is wrapped, while the other end is coiled so as to fit over a Bunsen burner. The asbestos is dipped in a strong solution of common salt and allowed to dry. When placed in position on the burner it gives a strong yellow flame. Metallic sodium burned on a platinum spoon in the flame gives an even intenser yellow flame. The eye is placed behind a simple direct-vision spectroscope (§ 401).

We thus see that when light from an intense source passes through the (cooler) sodium vapour those rays are absorbed by the vapour which it, itself, emits. The rest of the continuous spectrum is unaffected by the sodium vapour.

We conclude that the dark *D* lines in the sun's spectrum are due to the fact that the light which would naturally appear where they are has been absorbed by sodium vapour, and at once we obtain evidence of the constitution of the sun.

The inner portion of the sun is intensely hot and undoubtedly emits light of all colours or wave-lengths, which would produce a perfectly continuous spectrum. On coming through the vapours of elements which are in the solar atmosphere the light is robbed of some of its constituents, and the absence of these is shown by the dark lines. Thus we believe sodium to exist in the sun's atmosphere.

By comparing the positions of the dark solar lines with the positions of bright lines obtained by vaporizing various substances

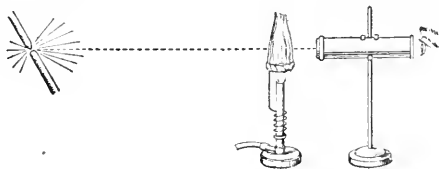

FIG. 422.--Light from the arc lamp passes through sodium vapour in the Bunsen flame and is then examined by the spectroscope. A dark band in the yellow is seen.

in our laboratories, it has been shown that sodium, iron, calcium, hydrogen, silver, titanium and about 30 more elements with which we are acquainted certainly exist in the sun. Others will probably be recognized. In the case of the gas helium the order of its discovery was reversed. For many years a remarkably intense line in the spectrum of the outer portion (the chromosphere) of the sun had been observed, and as it did not correspond to any known substance on the earth it was provisionally said to be due to *helium*, which means "solar substance."* In 1895, however, the chemist Ramsay discovered the long-sought substance in a rare mineral called cleveite.

The dark lines in the spectra of the moon and the planets are the same as those in the sun, showing that these bodies shine by reflected sunlight. In recent times the spectroscope has been applied to the stars. These are self-luminous bodies like our sun, and many terrestrial substances have been recognized in them. Thus the spectroscope reveals a wonderful unity in the entire universe. It is believed, also, that we can trace in the spectra of the stars the course of their formation, development and decay,—in other words, their life-history.

406. Effect of Motion of the Radiating Body. As explained in § 235, if a body which is emitting waves of any kind is in motion towards or away from the observer the wave-length of the radiation is thereby shortened or lengthened.

Now light is a wave-motion. Hence if a star is approaching us the lines in its spectrum will appear to be displaced towards the blue end; if it is receding from us the lines are displaced towards the red end. The actual displacements of the lines measured on the photographs of the star's spectrum, are extremely small, but by utilizing especially adapted instruments, and exercising great care the motions of many of the stars relative to our solar system have been determined with considerable accuracy. For instance it has been found that the pole star is approaching us at the rate of 16 miles per second, while Capella is receding from us at 15 miles per second.

Many other wonderful results have been deduced through the same principle. Campbell, of the Lick Observatory (on Mt. Hamilton, California), has shown that our entire solar system is moving through space, almost towards the bright star Vega, at the rate of about 12 miles per second. It may be remarked, however, that though we move at this great rate continually towards this star we shall require 310,000 years to make the journey thither.†

*Greek *Helios* = sun.

† Light requires 20 years to come from Vega to us.

QUESTIONS AND PROBLEMS

1. A ribbon purchased in daylight appeared blue, but when seen by gas-light it looked greenish. Explain this.
2. One piece of glass appears dark red and another dark green. On holding them together you cannot see through them at all. Why is this?
3. Where would you look for a rainbow in the evening? At what time can one see the longest bow? Under what circumstances could one see the bow as a complete circle?
4. An achromatic lens is composed of a converging lens of focal length 10 cm. and a diverging lens of focal length 15 cm. What is the focal length of the combination? (§ 384.)
5. On observing the spectrum of sodium vapour in a spectroscope two fine lines are seen close together. What will be the effect of widening the slit?

CHAPTER XL

OPTICAL INSTRUMENTS

407. The Eye. The most important as well as the most wonderful of optical instruments is the human eye. In form it is almost spherical (Fig. 423). The horny outer covering, the "white of the eye," is called the *sclerotic* coat. The front portion of this protrudes like a watch face and is called the *cornea*. Within the sclerotic is the *choroid* coat, and within this, again, is the *retina*.

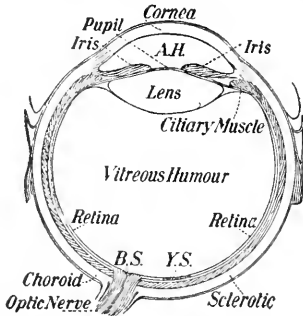

FIG. 423.—Horizontal section of a right eye. A.H., aqueous humour; F.S., yellow spot; B.S., blind spot.

The portion of the choroid coat visible through the cornea is called the *iris*. This forms an opaque circular diaphragm, which is variously coloured in different eyes. The aperture in it is called the *pupil*, and the size of the pupil alters involuntarily

to suit the amount of light which enters the eye. When the light is feeble the pupil is large. On passing from darkness into a brilliantly-lighted room the eye is at first dazzled, but the pupil soon contracts and keeps out the excessive supply of light.

Behind the pupil is the double-convex *crystalline lens*. The radii of curvature of its front and back surfaces are about 11 and 8 mm., respectively; but by means of the muscles attached to the edge of the lens, the curvature of its faces, and hence its converging power, can be changed at will.

The portion of the eye between the lens and the cornea is filled with a watery fluid called the *aqueous humour*, while between the lens and the retina is a transparent jelly-like substance called the *vitreous humour*.

The *retina* is a semi-transparent network of nerve-fibres formed by the spreading out of the termination of the optic nerve. Near the centre of the retina is a small round depression known as the *yellow spot*, and vision is most distinct if the image of the object

looked at is formed at this place. When one desires to see an object he turns his head until the image comes on the yellow spot. About $2\frac{1}{2}$ mm. from the yellow spot, towards the nose, is the *blind spot*, which is the place where the optic nerve enters the eye. This spot is insensitive to light.

The existence of this blind spot can easily be shown experimentally. On a piece of paper make a cross **X** and about 4 inches to the right of it make a circle **O**. Now cover the left eye, and while looking intently on the **X**, vary the distance of the paper from the eye. At a certain distance (7 or 8 inches) from the eye the **O** will be invisible, while at a greater or less distance it will be seen. It becomes invisible when its image falls on the blind spot, the image of the **X** being kept on the yellow spot all the time.

408. The Image on the Retina. The eye as a whole acts like a converging lens. It forms on the retina an inverted real image of the object before it. The fact that it is inverted can be shown in the following way.

Look at the sky through a pin-hole in a visiting card held about an inch from the eye, and then hold a pin-head between the eye and the small illuminated aperture and as near to the eye as possible (Fig. 424). It is clear that in this case the image* on the retina is erect, and yet it seems to be inverted. This shows that the brain recognizes as the highest part of an object that which gives rise to the lowest part of the image on the retina.

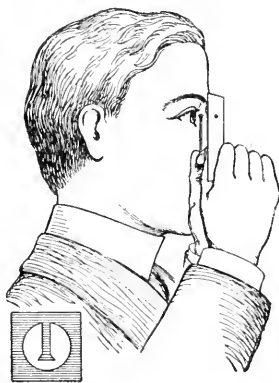

FIG. 424.—How to show that the image on the retina is inverted.

409. Accommodation. The eye when at rest is adjusted so that parallel rays entering it are focussed on the retina, that is, it is adjusted for viewing distant objects. Under these circumstances light from an object near at hand would be brought to a focus behind the retina (§§387, 388). But when we wish to see an object close at hand we involuntarily alter the curvature of the surfaces—chiefly the forward surface—of the crystalline lens, making it more convex, so that the image is brought upon the retina and we see it distinctly. This alteration of the converging power of the eye to adapt itself for near or distant objects is known as *accommodation*.

* It is not a true image, but a shadow cast upon the retina.

In order to see an object distinctly we naturally bring it near to the eye. As it approaches, our vision of it improves until it gets within a certain distance, and then we have to strain the eye to see it clearly, and when it gets too close the image is blurred. The shortest distance from the eye at which distinct vision can be obtained without straining the eye is known as the *least distance of distinct vision*. This distance for persons of normal vision is from 25 to 30 cm. (10 to 12 inches).

The magnifying power of an optical instrument depends on this quantity, and in calculating the magnification it is taken as 25 cm. or 10 inches, although as a matter of fact it is quite variable with different eyes.

410. Why we have Two Eyes. The images of a solid object, formed on the retinas of the two eyes, are not identical. On account of the distance between the eyes the right eye can see somewhat more of the right side of an object than is visible to the left eye. Thus we obtain an idea of the depth of the object.

The effect of depth or solidity to a picture is given by the stereoscope. Two photographs, taken from slightly different points of view, are mounted side by side, and are then viewed in the stereoscope. In this instrument there are two portions of a convex lens, or a kind of prismatic lens, placed with the edges toward each other (Fig. 425). Each lens gives an enlarged view of the picture, as in the simple microscope (§ 414), and the instrument is adjusted until these are produced on corresponding portions of the retinas of the two eyes. Under these circumstances they are seen as one, with the same effect as is obtained with the two eyes. The picture is no longer a flat lifeless thing, but the various objects in it stand out in relief.

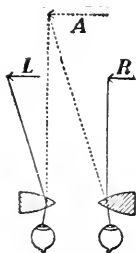

FIG. 425.—The stereoscope.

411. Defects of the Eyes. A person possessing normal vision can see distinctly objects at all distances varying from 8 or 10 inches up to infinity. But, as we well know, there are many eyes with defects, the chief of which are *short-sightedness*, *long-sightedness*, and *astigmatism*.

A short-sighted eye cannot see objects at any considerable distance from the eye. The image of an object near at hand is produced on the retina, but the eye cannot accommodate itself for one farther off. In such a case the image is formed in front of the retina, and to the

observer it appears blurred. In a short-sighted eye the lens is too strongly convergent, and in order to remedy this we must use spectacles producing the opposite effect, that is having diverging lenses.

A long-sighted eye, in its passive condition, brings parallel rays of light to a focus behind the retina. Such an eye can accommodate itself for distant objects, bringing the image forward to the retina; but for near objects its power of accommodation is not sufficient. In this case the crystalline lens is not converging enough, and in order to assist it spectacles with converging lenses should be used. As a person grows older there is usually a loss of the power of accommodation, and the eye becomes long-sighted, requiring the use of converging spectacles. In Fig. 426, F' is the position of the focus for parallel rays in a normal eye, F_1 for a short-sighted and F_2 for a long-sighted eye. These distances from the retina are greatly exaggerated in the diagram for the sake of clearness.

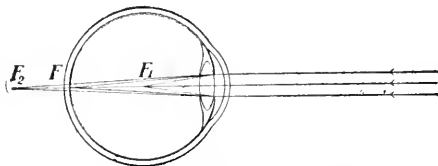

FIG. 426.—In a short-sighted eye parallel rays converge to a point before the retina; in a long-sighted eye, behind the retina.

The defect known as astigmatism is due to a lack of symmetry in the surfaces of the cornea and the lens, but principally in the former. Ordinarily these are spherical, but sometimes the curvature is greater in one plane than in others. If a diagram, as shown in Fig. 418, be drawn about one foot in diameter and viewed from a distance of about 15 feet an astigmatic eye will see some of the radii distinctly, while those in a perpendicular direction will be blurred. In most cases the vertical section of the cornea of an astigmatic eye is more curved than a horizontal section. The proper spectacles to use are those in which one surface of the lens is a part of a cylinder instead of a sphere.

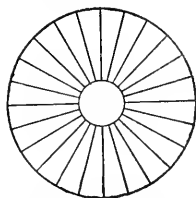

FIG. 427.—Diagram for testing for astigmatism.

412. The Photographic Camera. The pin-hole camera was described in §333. This would be quite satisfactory for taking photographs, except for the fact that as the pin-hole is very small, little light can get through it and so the time of exposure is long. This serious defect is overcome by making the hole larger and putting in it a converging lens. The greater the aperture of this lens is, provided the focal length is not increased, the shorter the exposure required.

In Fig. 428 is illustrated an ordinary camera. In the tube *A* is the lens, and at the other end of the apparatus is a frame *C* containing a piece of ground glass. By means of the bellows *B* this is moved back and forth until the scene to be photographed is sharply focussed on the ground glass. Then a holder containing a sensitive plate or film is inserted in front of the frame *C*, the sensitized surface taking exactly the position previously occupied by the ground surface of the glass.

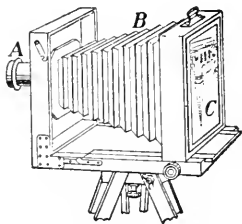

FIG. 428.—A photographic camera.

The exposure is then made, that is, light is admitted through the lens to the sensitive plate, after which, in a dark room, the plate is removed from its holder, developed and fixed.

Only in the cheapest cameras is a single convex lens used, a combination of two lenses being ordinarily found. If we wish to secure a picture which is perfectly focussed all over the plate, and to have a very short exposure, we must use one of the modern objectives, which have been brought to a high degree of efficiency. A section of one of these is shown in Fig. 429, in which it will be seen there are four separate lenses combined. Others contain even more lenses, and as these are made from special kinds of glass and have surfaces with specially computed curvatures, they are expensive. Great effort and marvellous ingenuity have been expended in producing the extremely compact and efficient cameras now so familiar to us.

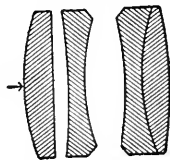

FIG. 429.—Section of a Zeiss "Tessar" photographic objective. The light enters in the direction shown by the arrow.

413. The Projection Lantern. In Fig. 430 is shown a vertical section of a projecting lantern. Its two essential parts are the source of light *A* and the projecting lens, or set of lenses, *D*.

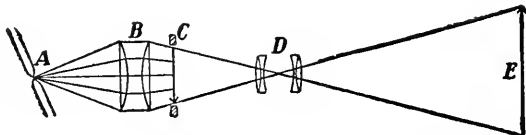

FIG. 430.—Diagram illustrating the action of a projection lantern.

The source should be as intense as possible. [Why?] In the figure it

is an electric arc lamp, but the lime-light (a cylinder of lime made white-hot by the oxy-hydrogen flame), an acetylene jet or a strong oil lamp may be used. The light diverging from the source is directed by means of the so-called *condensing lenses* B upon the object C which we wish to exhibit on the screen E . This object is usually a photograph on glass, and is known as a lantern slide.

In a tube is D the projecting lens. By moving this nearer the slide or farther from it a real and much enlarged image of the picture on the slide is produced on the screen. The slide and the screen are conjugate foci (§§ 385, 388). As the image on the screen is erect, and since the projecting lens inverts the image, it is evident that the slide C must be placed in its carrier with the picture on it upside down.

414. The Simple Microscope or Magnifying Glass. In order to see an object well, that is, to recognize details of it, we bring it near to the eye, but we have learned (§ 409) that when it gets within a certain distance the image is blurred. By placing a single convex lens before the eye (which is equivalent to making the eye short-sighted) we are enabled to bring the object quite close to the eye and still have the image of it on the retina distinct.

How this is done is shown in Fig. 431. (See also Figs. 396-400.) The object PQ is placed within the principal focus F . The image pq is virtual, erect and enlarged (see Fig. 397). The lens is moved back and forth until the image is focussed, in which case the image is at the least distance of distinct vision from the eye. The magnification is greatest when the eye is close to the lens.

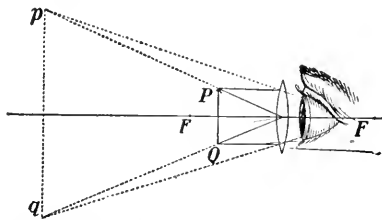

FIG. 431.—Illustrating the action of the simple microscope.

415. Magnifying Power of Simple Microscope. Let us find the magnification. The apparent size of an object is determined by

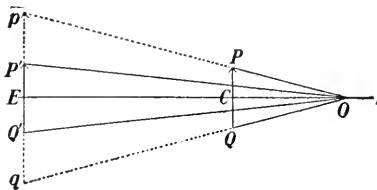

FIG. 432.—The magnification is the ratio of $p'q'$ to PQ .

the size of the angle subtended at the eye by the object. Consider the eye to coincide in position with the lens. Then in Fig. 432 the angle subtended at the eye by the object PQ is $P'OQ$, that subtended by the image $p'q'$ is $p'Oq'$. These angles are identical and at first sight we might think

there was no magnification. It must be noted, however, that if we were looking at $P'Q$ directly, without using the lens, we would place it at $P'Q'$, at the same distance from O as $p'q'$, and the angle then subtended at the eye is $P'OQ'$.

$$\text{Hence magnification} = \frac{\text{angle } p'Oq'}{\text{angle } P'OQ'} = \frac{p'q'}{P'Q'} \text{ (approx.)} = \frac{p'q'}{PQ}.$$

Now OPQ and $Op'q'$ are similar triangles, and OC , OE are perpendiculars from O upon corresponding sides PQ , $p'q'$.

$$\text{Hence } \frac{p'q'}{PQ} = \frac{OE}{OC}.$$

Again PQ is always placed near the principal focus of the lens, and if f is its focal length, $OC = f$ approximately. Also putting $OE = \Delta$, the least distance of distinct vision, we have

$$\text{Magnification} = \frac{\Delta}{f}.$$

For example, if focal length = 1 cm. and $\Delta = 25$ cm., then magnification = $25 \div 1 = 25$.

It might be noted that since P , the *power* of a lens, is inversely proportional to its focal length (§ 382)

$$\text{Magnification} = \Delta \times P.$$

The smaller the focal length the greater is the power and also the magnification. The greatest magnification, however, which can be obtained is about 100.

416. The Compound Microscope. For higher magnifications we must use a combination of convex lenses known as a compound microscope. In its simplest form it consists of two lenses, the objective and the eyepiece, the action of which is illustrated in Fig. 433.

The object PQ is placed at A , before the objective O and just beyond its principal focus. Thus a real enlarged inverted image $P'Q'$ is produced at B , and the eyepiece E is so placed that $P'Q'$ is

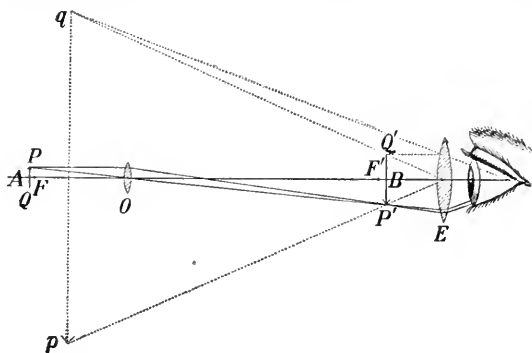

FIG. 433.—Diagram illustrating the compound microscope.

just within its focal length. The eyepiece E then acts as a simple microscope magnifying $P'Q'$. It forms an enlarged virtual image pq at the distance of distinct vision from the eye. This distance is approximately the length L of the microscope tube.

We see, then, that the objective and the eyepiece both magnify the object, and the total magnification is obtained by *compounding* (*i.e.*, multiplying) these two magnifications.

The magnification produced by the objective

$$= \frac{P'Q'}{PQ}, \text{ which } = \frac{BO}{AO} \text{ (see } \S \text{ 389).}$$

Now $AO = F$, the focal length of objective, approximately,

and $BO = L$, the length of the microscope tube, approximately.

$$\text{Hence } \frac{P'Q'}{PQ} = \frac{L}{F}, \text{ approximately.}$$

Also, if $f =$ focal length of eyepiece (in cm.),

$$\text{Magnification by eyepiece } = \frac{25}{f} \text{ (§ 415)}$$

$$\text{and total magnification } = \frac{L}{F} \times \frac{25}{f} = \frac{25L}{Ff}.$$

417. The Astronomical Telescope. The arrangement of the lenses in the astronomical telescope is the same in principle as in the compound microscope. In the case of the latter, however, the object to be observed is near at hand and we can place it near the

objective. Under these circumstances a lens of short focal length is best to use.

But the objects viewed by the telescope are far away, and we

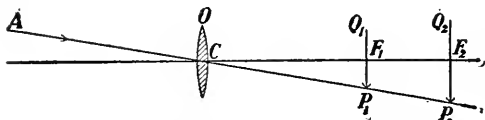

FIG. 434.—Showing why the objective of an astronomical telescope should have a long focus.

must use an objective with as great a focal length as possible. The reason for this will be evident from Fig. 434. Let

AC be a ray from the upper part of the

object looked at, passing through the centre C of the objective O . Now the image of an object at a great distance is formed at the principal focus. If then F_1 is the principal focus P_1Q_1 is the image, and if F_2 is the principal focus P_2Q_2 is the image. It is clear that P_2Q_2 is greater than P_1Q_1 , and indeed that the size varies directly as the focal length. Hence the greater the focal length of the objective the larger will be the image produced by it.

Further, since the celestial bodies (except the sun) are very faint, the diameter of the objective should be large, in order to collect as much light from the body as possible.

A diagram illustrating the action of the telescope is given in Fig.

435. The objective forms the image at its principal focus B , that is $OB = F$, its focal length. This is further magnified by the eyepiece E , which forms the image at pq . B is just within the principal focus of the eyepiece, and so OE , the distance between objective and eyepiece, is approximately equal to $F + f$ the sum of their focal lengths.

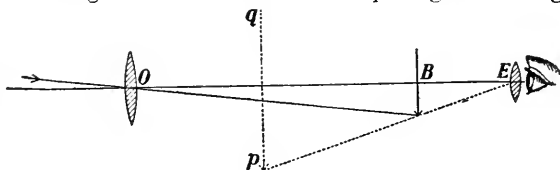

FIG. 435.—The astronomical telescope.

The magnification produced by the telescope is equal to F/f , though we cannot here deduce this formula.*

The magnification produced by the telescope is equal to F/f , though we cannot here deduce this formula.*

In the great telescope of the Lick Observatory the diameter of the objective is 36 inches and its focal length is 57 feet. On using an eyepiece of focal length $\frac{1}{2}$ inch the magnification is 1368. The diameter of the Yerkes telescope (belonging to the University of Chicago) is 40 inches and its focal length is 62 feet.

* See Ganot's *Physics*; or Watson's *Physics*, p. 492.

418. Objectives and Eyepieces. In telescopes the objective usually consists of an achromatic pair of lenses as shown in Fig. 411, the lenses being sometimes cemented together, at others times separated a small distance. Some objectives are now made up of three lenses. The objective of the microscope is frequently a complicated system of lenses (Fig. 412).

There are two chief types of eyepieces, known as positive and negative. The simplest example of the former is that devised by Ramsden. It consists of two plano-convex lenses of equal focal

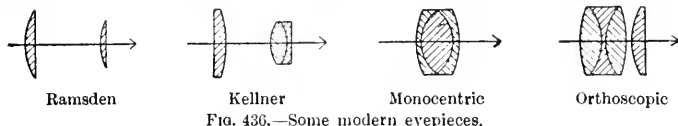

FIG. 436.—Some modern eyepieces.

length and $\frac{2}{3}$ of that length apart. Other more modern eyepieces are shown in Fig. 436. These are used in telescopes when we wish to make measurements, such as the space between two stars or the diameter of a planet. They can be used as simple microscopes, as the principal focus is outside the lenses.

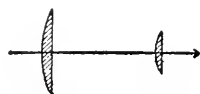

FIG. 437.—The Huygens eyepiece.

The Huygens eyepiece has two plano-convex lenses (Fig. 437), the one next the eye having a focal length $\frac{1}{2}$ that of the other, and the distance between being twice the focal length of the shorter. This eyepiece is ordinarily found in microscopes, and it cannot be used as a simple microscope.

419. The Opera Glass. The opera glass has a convex lens for objective and a concave lens for eyepiece (Fig. 438). Light from

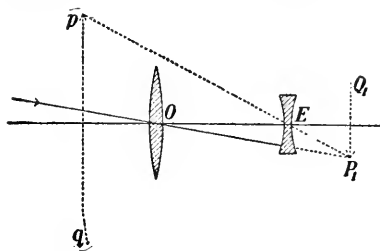

FIG. 438.—A section of the ordinary opera glass.

the object passes through the objective O , and would, if allowed to do so, form a real image P_1Q_1 . But a concave lens E , placed in its way, diverges the rays so that on entering the eye they seem to come from pq . This image is erect and virtual.

This instrument is also known as Galileo's telescope.

It was devised by this great man, and with it he discovered the first four satellites of Jupiter (1610), and also Saturn's Ring.

Ordinary opera or field-glasses consist of two Galilean telescopes, one for each eye. Such telescopes are simple in construction, of

convenient length and give an image right-side-up, but their field of view is not very great and they are not very serviceable for high magnification.

420. Terrestrial Telescope. When an ordinary telescope is to be used for terrestrial purposes it is inconvenient to have the image inverted, and to overcome this an "erecting eyepiece" is employed. This contains, in addition to the ordinary eyepiece, two lenses of equal focal length placed so that they simply erect the image without otherwise altering it. Such an eyepiece also increases the field of view.

421. The Prism Binocular. In recent years there has come into use the prism binocular, which combines the compact form of the Galilean telescope with the wide field of view of the terrestrial telescope.

Its construction is illustrated in Figs. 439 and 440. The former shows the appearance of the instrument, while the latter shows the optical arrangement. The lenses are precisely the same as in an astronomical telescope, but the compactness is obtained by using two reflection prisms. The light traverses the length of the instrument three times, which reduces the necessary length, while the reflections from the faces of the prisms erect the image. The field of view is from 7 to 10 times as great as with ordinary field-glasses of the same power.

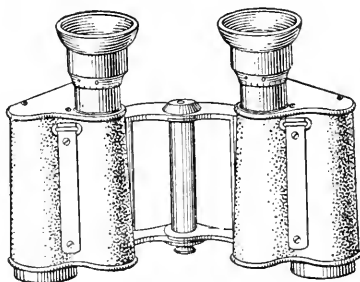

FIG. 439.—The prism binocular.



FIG. 440.—Showing the path of the light.

The use of prisms was devised by Porro about 60 years ago, but on account of difficulties in their manufacture they did not come into use until quite recently.

In the form shown in Fig. 439, that made by Zeiss, a further advantage is in the enhanced stereoscopic power. It will be seen that the distance between the objectives is about $1\frac{3}{4}$ times as great as between the eyepieces, and hence the stereoscopic power is multiplied that many times.

CHAPTER XLI

MAGNETISM

422. Natural Magnets. In various countries there is found an ore of iron which possesses the remarkable power of attracting small bits of iron. Specimens of this ore are known as *natural magnets*. This name is derived from Magnesia, a town of Lydia, Asia Minor, in the vicinity of which the ore is supposed to have been abundant. Its modern name is magnetite. It is composed of iron and oxygen, the chemical formula for it being Fe_3O_4 .

If dipped in iron filings many will cling to it, and if it is suspended by an untwisted fibre it will come to rest in a definite position, thus indicating a certain direction. On account of this it is known also as a *lodestone*, (*i.e.*, leading-stone) Fig. 441.

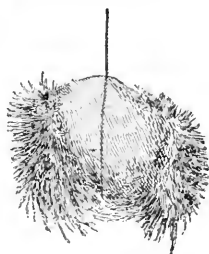

FIG. 441.—Iron filings clinging to a natural magnet.

423. Artificial Magnets. If a piece of steel is stroked over a natural magnet it becomes itself a magnet. There are, however, other and more convenient methods of magnetizing pieces of steel (§ 502), and as steel magnets are much more powerful and more convenient to handle than natural ones, they are always used in experimental work.

Permanent steel magnets are usually of the bar, the horse-

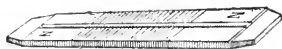

FIG. 442.—Bar-magnets.



FIG. 443.—A horse-shoe magnet.

shoe or the compass needle shape, as illustrated in Figs. 442, 443, 444.

424. Poles of a Magnet. Iron filings when scattered over a bar-magnet are seen to adhere to it in tufts near the ends,

none, or scarcely any, being found at the middle (Fig. 445).

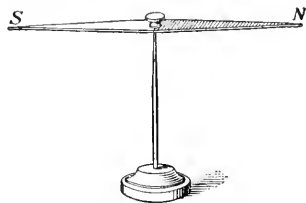

FIG. 444.—A compass-needle magnet.

The strength of the magnet seems to be concentrated in certain places near the ends; these places are called the *poles* of the magnet, and



FIG. 445.—The filings cling mostly at the poles.

a straight line joining them is called the *axis* of the magnet. If the magnet is suspended so that it can turn freely in a horizontal plane (Fig. 444) this axis will assume a definite north-and-south direction, in what is known as the *magnetic meridian*, which is usually not far from the geographical meridian. That end of the magnet which points north is called the *north-seeking*, or simply the *N-pole*, the other the *south-seeking* or *S-pole*.

425. Magnetic Attraction and Repulsion. Let us bring the *S-pole* of a bar-magnet near to the *N-pole* of a compass needle (Fig. 446). There is an attraction between them. If we present the same pole to the *S-pole* of the needle, it is repelled. Reversing the ends of the magnet, we find that its *N-pole* now attracts the *S-pole* of the needle but repels the *N-pole*.

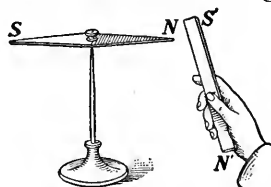

FIG. 446.—The *S-pole* of one magnet attracts the *N-pole* of another.

We thus obtain the law:—*Like magnetic poles repel, unlike attract each other.*

This experiment can be repeated with very simple means. Magnetize two sewing-needles by rubbing them, always in the same direction, against one pole of a magnet. Then thrust them into corks floating on the surface of water. On pushing one over near the other, the attractions and repulsions will be beautifully shown.

It is to be observed that unmagnetized iron or steel will be attracted by *both* ends of a magnet. It is only when both bodies are magnetized that we can obtain repulsion.

426. Magnetic Substances. A magnetic substance is one which is attracted by a magnet. Iron and steel are the only substances which exhibit magnetic effects in a marked manner. Nickel and cobalt are also magnetic, but in a much smaller degree. In recent years Heusler, a German physicist, has discovered a remarkable series of alloys possessing magnetic properties. They are composed of manganese (about 25 per cent.), aluminium (from 3 to 15 per cent.) and copper. These substances taken singly are non-magnetic, but when melted together are able easily to affect the magnetic needle.

On the other hand, bismuth, antimony and some other substances are actually repelled by a magnet. These are said to be *diamagnetic* substances, but their action on a magnet is very weak. For all practical purposes iron and steel may be considered to be the only magnetic substances.

427. Induced Magnetism. If a piece of iron rod, or a nail,* be held near one pole of a strong magnet, it becomes itself a magnet, as is seen by its power to attract iron filings or small tacks placed near its lower end (Fig. 447). If the nail be allowed to touch the pole of the magnet, it will be held there.

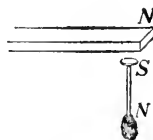

FIG. 447.—A nail held near a magnet becomes itself a magnet by induction.

A second nail may be suspended from the lower end of this one, a third from the second, and so on. (Fig. 448.) On removing the magnet, however, the chain of nails falls to pieces.

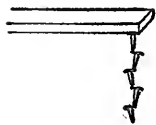

FIG. 448.—A chain of magnets by induction.

We thus see that a piece of iron becomes a *temporary* magnet when it is brought near one pole of a permanent steel magnet. Its polarity can be tested in the following way:—

*Ordinary steel nails are not very satisfactory. Use clout nails or short pieces of stove-pipe wire.

Suspend a bit of soft-iron (a narrow strip of tinned-iron is very suitable), and place the *N*-pole of a bar-magnet near it (Fig. 449). Then bring the *N*-pole of a second bar-magnet near

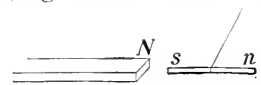

FIG. 449.—Polarity of induced magnetism.

the end *n* of the strip, farthest from the first magnet. It is repelled, showing that it is a *N*-pole. Next bring the *S*-pole of the second magnet slowly towards the end *s* of the strip. Repulsion is again observed. This shows, as we should expect from the law of magnetic attraction and repulsion (§ 425), that the induced pole is opposite in kind to that of the permanent magnet adjacent to it.

428. Retentive Power. The bits of iron in Figs. 447, 448, 449, retain their magnetism only when they are near the magnet; when it is removed, their polarity disappears.

If hard-steel is used instead of soft-iron, the steel also becomes magnetized, but not as strongly as the iron. However, if the magnet is removed the steel will still retain some of its magnetism. It has become a *permanent* magnet.

Thus steel offers great resistance both to being made a magnet and to losing its magnetism. It is said to have great *retentive power*.

On the other hand, soft-iron has small retentive power. When placed near a magnet, it becomes a stronger magnet than a piece of steel would, but it parts with its magnetism quite as easily as it gets it.

429. Field of Force about a Magnet. The space about a magnet, in any part of which the force from the magnet can be detected, is called its *magnetic field*.

One way to explore the field is by means of a small compass needle. Place a bar-magnet on a sheet of paper and slowly move a small compass needle about it. The action of the two poles of the magnet on the poles of the needle will cause the latter to set itself at various points along lines which indicate the direction of the force from the magnet. These

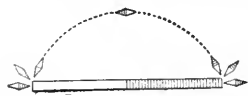

FIG. 450.—Position assumed by a needle near a bar-magnet.

curves run from one pole to the other. In Fig. 450 is shown the direction of the needle at several points, as well as a line of force extending from one pole to the other.

Another way to map the field is by means of iron filings. This is very simple and very effective. Place a sheet of paper over the magnet, and

sift from a muslin bag iron filings evenly and thinly over it. Tap the paper gently. Each little bit of iron becomes a magnet by induction, and tapping the paper assists them to arrange themselves along the magnetic lines of force. Fig. 451 exhibits the field about a bar-magnet,

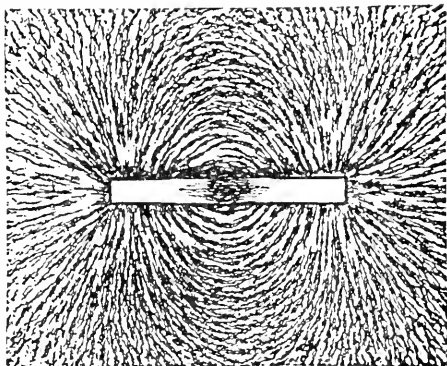

FIG. 451.—Field of force of a bar-magnet.

while Fig. 452 shows it about similar poles of two bar-magnets standing on end.

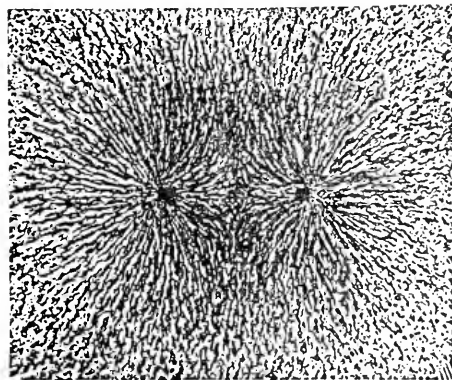

FIG. 452.—Field of force of two like poles.

indicates the strength of the magnetic force there.

The magnetic force, as we have seen, is greatest in the neighbourhood of the poles, and here the curves shown by the filings are closest together. Thus the direction of the curves indicates the direction of the lines of force, and their closeness together at any point

There are several ways of making these filings figures permanent. Some photographic process gives the best results, but a convenient way is to produce the figures on paper which has been dipped in melted paraffin, and then to heat the paper. The filings sink into the wax and are held firmly in it when it cools down.

430. Properties of Lines of Force.

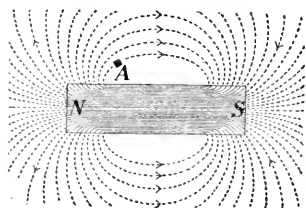

FIG. 453.—The lines of force run from the *N*-pole through the surrounding medium to the *S*-pole, and then through the magnet back to the starting point.

The lines of force belonging to a magnet are considered to begin at the *N*-pole, pass through the surrounding space, enter at the *S*-pole and then continue through the magnet to the *N*-pole again (Fig. 453). Thus each line of force is a closed curve. It is evident, also, that if we could detach a *N*-pole from a magnet and place it on any line of force, at *A* for instance, it would move along

that line of force until it would come to the *S*-pole.

Great use is made of the conception of lines of force in computations in magnetism and electricity, for example, in designing dynamos. This method of dealing with the subject was introduced by Faraday about 1830.

431. Magnetic Shielding. Most substances when placed in a magnetic field make no appreciable change in the force, but there is one pronounced exception to this, namely iron.

Place a bar-magnet with one pole about 10 cm. from a large compass needle (Fig. 454).



MICHAEL FARADAY (1791-1867). Born and lived in London. The greatest of experimental scientists. His discoveries form the basis of all our applications of electricity.

Pull aside the needle and let it go. It will continue vibrating for some time. Count the number of vibrations per minute. Then push the magnet up until it is 6 cm. from the needle, and again time the vibrations. They will be found to be much

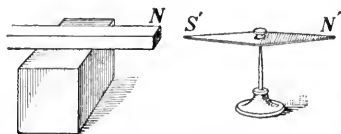

FIG. 454.—Arrangement for testing magnetic shielding.

faster. Next, put the magnet 3 cm. from the needle; the vibrations will be still more rapid. Thus, the stronger the force of the magnet on the needle, the faster are the vibrations.

Now while the magnet is 3 cm. from the needle place between them a board, a sheet of glass or of brass, and determine the period of the needle. No change will be observed. Next, insert a plate of iron. The vibrations will be much slower, thus showing that the iron has shielded the needle from the force of the magnet.

The lines of force upon entering the iron simply spread throughout it, meeting less resistance in doing so than in moving out into the air again. A space surrounded by a thick shell of iron is effectually protected from external magnetic force.

432. Magnetic Permeability. The lines of force pass more easily through iron than through air. Thus iron has greater *permeability* than air, and the softer the iron is the greater is its permeability. Hence when a piece of iron is placed in a magnetic field, many of the lines of force are drawn together and pass through the iron. This explains why soft-iron becomes a stronger magnet by induction than does hard-steel.

433. Each Molecule a Magnet. On magnetizing a knitting needle or a piece of clock-spring (Fig. 455) it exhibits a pole at each end, but no magnetic effects at the centre. Now break it at the middle. Each part is a magnet. If

we break these portions in two, each fragment is again a magnet. Continuing this, we find that each free end always

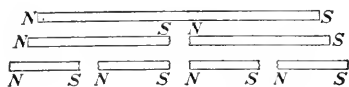

FIG. 455.—Each portion of a magnet is a magnet.

gives us a magnetic pole. If all the parts are closely joined again the adjacent poles neutralize each other and we have only the poles at the ends, as

before. If a magnet is ground to powder each fragment still acts as a little magnet and shows polarity.

Again, if a small tube filled with iron filings is stroked from end to end with a magnet it will be found to possess polarity, which, however, will disappear if the filings are shaken up.

All these facts lead us to believe that each molecule is a little magnet. In an unmagnetized iron bar they are arranged in an irregular, haphazard, fashion (Fig. 456), and so there is

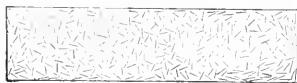

FIG. 456.—Haphazard arrangement of molecules of iron ordinarily.

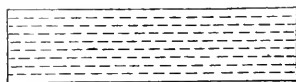

FIG. 457.—Arrangement of molecules of iron when magnetized to saturation.

no combined action. When the iron is magnetized the molecules turn in a definite direction. Striking the rod while it is being magnetized assists the molecules to take up their new positions. On the other hand rough usage destroys a magnet. When the magnet is made as strong as it can be the molecules are *all* arranged in regular order, as illustrated in Fig. 457.

The molecules of soft-iron can be brought into alignment more easily than can those of steel, but the latter retain their positions much more tenaciously.

434. Effect of Heat on Magnetization. A magnet loses its magnetism when raised to a bright red heat, and when iron is heated sufficiently it ceases to be attracted by a magnet. This can be nicely illustrated in the following way. Heat a cast-iron ball, to a white heat if possible, and suspend it at a little distance from a magnet. At first it is not attracted at all, but on cooling to a bright red it will be suddenly drawn in to the magnet.

The Heusler alloys, mentioned in §426, behave peculiarly in respect to temperature. Above a certain temperature they are entirely non-magnetic. The temperature depends upon the proportions of aluminium and manganese present.

435. Mariner's Compass. In the modern ship's compass several magnetized needles are placed side by side, such a compound needle being found more reliable than a single one. The card, divided into the 32 "points of the compass," is itself attached to the needle, the whole being delicately poised on a sharp iridium point.

436. The Earth a Magnet. The fact that the compass needle assumes a definite position suggests that the earth or some other celestial body exerts a magnetic action. William Gilbert,* in his great work entitled *De Magnete* (*i.e.*, "On the Magnet"), which was published in 1600, demonstrated that our earth itself is a great magnet.

In order to illustrate his views Gilbert had some lodestones cut to the shape of spheres; and he found that small magnets turned towards the poles of these models just as compass needles behave on the earth.

The magnetic poles of the earth, however, do not coincide with the geographical poles. The north magnetic pole was

*Gilbert (1540-1603) was physician to Queen Elizabeth, and was England's first great experimental scientist.

found by Sir James Ross* on June 1, 1831, on the west side of Boothia Felix, in N. Lat. $70^{\circ} 5'$, W. Long. $96^{\circ} 46'$. In 1904-5 Roald Amundsen, a Norwegian, explored all about the pole. Its present position is about N. Lat. 70° , W. Long. 97° , not far from its earlier position.

The south magnetic pole was only recently attained. On January 16, 1909, three members of the expedition led by Sir Ernest Shackleton discovered it in S. Lat. $72^{\circ} 25'$, E. Long. $155^{\circ} 16'$. In both cases the magnetic pole is over 1100 miles from the geographical pole, and a straight line joining the two magnetic poles passes about 750 miles from the centre of the earth.

437. Magnetic Declination. We are in the habit of saying that the needle points north and south, but it has long been known that this is only approximately so. Indeed, knowing that the magnetic poles are far from the geographical poles, we would not expect the needle (except in particular places) to point to the true north. In addition, deposits of iron ore and other causes produce local variations in the needle. The angle which the axis of the needle makes with the true north-and-south line is called the *magnetic declination*.

438. Lines of Equal Declination or Isogonic Lines. Lines upon the earth's surface through places having the same declination are called *isogonic* lines; that one along which the declination is zero is called the *agonic*† line. Along this line the needle points exactly north and south.

On January 1, 1910, the declination at Toronto was $5^{\circ} 55'$ W. of true north, at Montreal, $15^{\circ} 4'$ W., at Winnipeg, $14^{\circ} 4'$ E., at Victoria, B.C., $24^{\circ} 25'$ E., at Halifax, $21^{\circ} 14'$ W. These values

* The cost of the arctic expedition, which was made by John Ross and his nephew James, was defrayed by a wealthy Englishman named Felix Booth.

† Greek, *isos* = equal, *gonia* = angle; *a* = not, *gonia* = angle.

are subject to slow changes. At London, in 1580, the declination was $11^{\circ} 17'$ E. This slowly decreased, until in 1657 it was $0^{\circ} 0'$. After this it became west and increased until in 1816 it was $24^{\circ} 30'$; since then it has steadily decreased and is now $15^{\circ} 3'$ W.

In Fig. 458 is a map showing the isogonic lines for the United States and Canada for January 1, 1910.

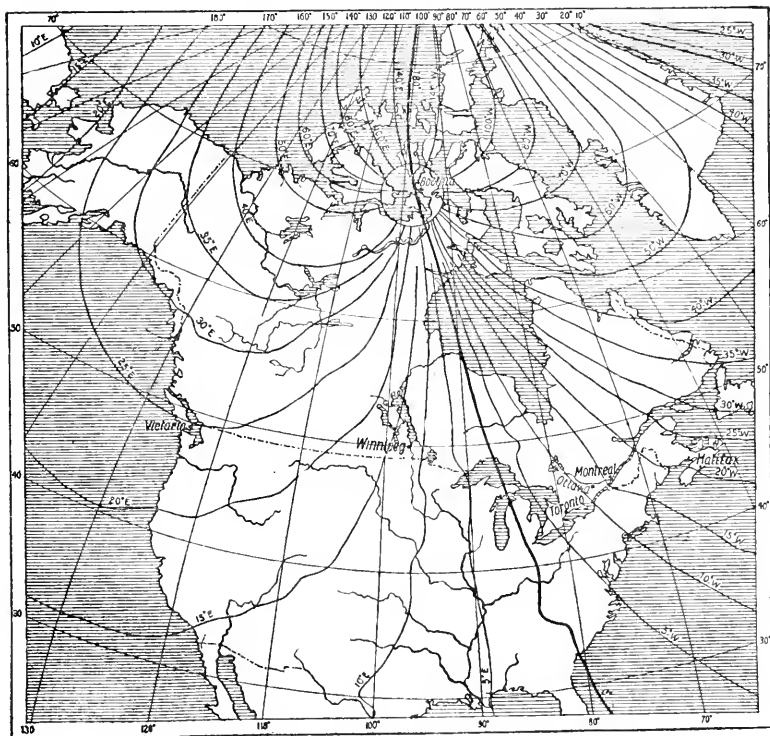

FIG. 458. — Isogonic Lines for Canada and the United States (January 1, 1910).

The data for regions north of latitude 55° are very meagre and discordant; the regions west of Hudson Bay where recent determinations have been made show considerable local disturbance; the lines north of latitude 70° are drawn largely from positions calculated theoretically, but modified where recent observations have been made. The above map was kindly drawn for this work by the Department of Research in Terrestrial Magnetism of the Carnegie Institution of Washington.

439. Magnetic Inclination or Dip. Fig. 459 shows an instrument in which the magnetized needle can move in a vertical plane. The needle before being magnetized is so adjusted that it will rest in any position in which it is placed, but when magnetized the *N*-pole (in the northern hemisphere) dips down, making a considerable angle with the horizon. If the magnetization of the needle is reversed, the other end dips down. Such an instrument is called a *dipping needle*. When using it the axis of rotation should point east and west (*i.e.*, at right angles to the *magnetic* meridian), and the needle should move with the least possible friction.

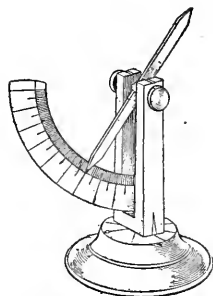

FIG. 459.—A simple dipping needle.

The angle which the needle makes with the horizon is called the *inclination* or *dip*. At the *magnetic* equator the dip is zero (or the needle is horizontal), but north or south of that line the dip increases, until at the magnetic poles it is 90° . Indeed the location of the poles was determined by the dipping needle.

At Toronto the dip is $74^\circ 37'$; at Washington, $71^\circ 5'$.

440. The Earth's Magnetic Field. As the earth is a great magnet it must have a magnetic field about it, and a piece of iron in that field should become a magnet by induction. If an iron rod (*e.g.*, a poker, or the rod of a retort stand) is held nearly vertically, with the lower end inclined towards the north, it will be approximately parallel to the lines of force and it will become magnetized. If struck smartly when in this position its magnetism will be strengthened. (Why?) Its magnetism can be tested with a compass needle. Carefully move the lower end towards the *S*-pole; it is attracted.

Move it near the N -pole; it is repelled. This shows the rod to be a magnet.

Now when a magnet is produced by induction its polarity is opposite to that of the inducing magnet. Hence we see that what we call the north magnetic pole of the earth is opposite in kind to the N -pole of a compass needle.

Iron posts in buildings and the iron in a ship when it is being built become magnetized by the earth's field.

CHAPTER XLII

ELECTRICITY AT REST

441. Electrical Attraction. If a stick of sealing-wax or a rod of ebonite (hard rubber) be rubbed with flannel or with cat's fur and then held near small bits of paper, pith or other light bodies, the latter will spring towards the wax or the ebonite. A glass rod when rubbed with silk acts in the same way.*

As early as 600 B.C. it was known that amber possessed this wonderful attractive power on being rubbed. The Greek name for amber is *electron*, and when Gilbert (see § 436) found that many other substances behaved in the same way he called them all *electrics*. The bodies which have acquired this attractive power are said to be *electrified* or to be *charged with electricity*. In later times it has been shown that *any* two different bodies when rubbed together become electrified.

A good way to observe the force of attraction is to use a

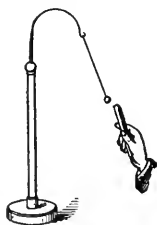

FIG. 460.—A pith ball on the end of a silk thread drawn towards the electrified rod.

small ball of elder pith or of cork, hung by a silk thread (Fig. 460). On holding the rubbed glass near it the ball is drawn towards it.

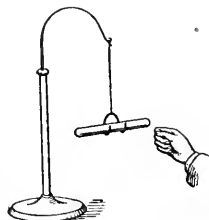

FIG. 461.—The electrified rod moves towards the hand.

It can also be shown that the electrified body is itself attracted by one that has not been electrified. Let us rub a glass rod and hang it in a wire stirrup supported by a silk thread (Fig. 461). If the

* In these experiments the substances should be thoroughly dry. They succeed better in winter since there is much less moisture in the air then.

hand (or other body) be held out towards the suspended body the latter will turn about and approach the hand. A rod of sealing-wax or of ebonite when rubbed acts similarly.

442. Electrical Repulsion. Suppose, however, we allow the pith ball (Fig. 460) to touch the electrified glass rod. It clings to it for a moment and then flies off. If the end of the rod is brought near to it, the ball continually moves away from it. There is repulsion between the two. Next, rub an ebonite rod with flannel and hold it to the pith ball. It is attracted. Thus the glass now repels the pith ball, but the ebonite attracts it.

Again, hold a rubbed glass rod near the suspended glass rod (Fig. 461); they repel each other. Two ebonite rods behave similarly. If, however, we hold a rubbed ebonite rod near the glass rod there is attraction between them.

443. Two Kinds of Electrification. It is evident from these experiments that there are two kinds of electrification or of electrical charge, and it is customary to call that produced on rubbing glass with silk *positive*; that produced on rubbing ebonite or sealing-wax with flannel, *negative*. The pith ball on touching the glass became charged positively.

The above and numberless other experiments allow us to formulate the following:—

LAW OF ELECTRICAL ATTRACTION AND REPULSION.—*Electrical charges of like kind repel each other, those of unlike kind attract each other.*

444. Conductors and Non-conductors. We may rest a piece of electrified ebonite on another piece of ebonite or on dry glass, or sulphur or paraffin, and it will retain its electrification for some time; but if it is passed through a flame, or is gently rubbed over with a damp cloth, or simply with the

hand, it loses its electrification at once. The ebonite, the glass, the sulphur and the paraffin are said to be *non-conductors* of electricity; while the damp cloth and the hand are said to be *conductors* of electricity, the electric charge escaping freely by way of them.

If we hold a piece of brass tube in the hand and rub it with fur or flannel or silk it will show no signs of electrification; but fasten it to an ebonite handle and flick it with dry cat's fur and it will be negatively electrified. Approach it to a suspended rubbed ebonite rod (Fig. 461) and it will repel it. In the first case the brass was electrified, but the electrical charge immediately escaped to earth by way of the experimenter's body. In the second case the escape was prevented by the ebonite handle, and the metal remained electrified. It is to be noted, too, that a non-conductor exhibits electrification only where it is rubbed, while in a metal the charge is spread all over its surface.

Those substances which lead off an electrical charge quickly are called *conductors*, while those which prevent the charge from escaping are called *non-conductors* or *insulators*. If a conductor is held on a non-conducting support it is said to be *insulated*. Thus, telegraph and telephone wires are held on glass insulators; and a man who is attending electric street lamps often stands on a stool with glass feet, and handles the lamps with rubber gloves.

GOOD CONDUCTORS: metals.

FAIR CONDUCTORS: the human body, solutions of acids and salts in water, carbon.

POOR CONDUCTORS: dry paper, cotton, wood.

BAD CONDUCTORS, OR GOOD INSULATORS: glass, porcelain, sealing-wax, mica, dry silk, shellac, rubber, resin, and oils generally.

445. The Gold-leaf Electroscope. The object of the electroscope is to detect an electric charge and to determine

whether it is positive or negative. A metal rod with a knob or disc at the top (Fig. 462) extends through a well-insulated cork into a flask. From its lower end two leaves of gold or of aluminium leaf hang by their own weight. The rod may pass through a glass tube, well coated with shellac, which is inserted through the cork. The flask should be also varnished with shellac, as this improves the insulation greatly. If a charge, either positive or negative, is given to the electroscopes, the two leaves, being charged with electricity of the same kind, repel each other and separate.



FIG. 462.—The Gold-leaf Electroscopes.

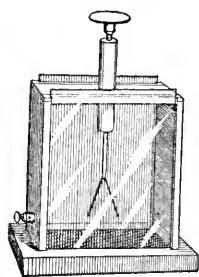

FIG. 463.—Another form of electroscopes.

Another form of electroscopes is shown in Fig. 463. The protecting case is of wood with front and back of glass. The sides of the case are lined with tin-foil, to which a binding post is connected. By this the case may be joined to earth and thus be kept constantly at zero potential (see § 455). The rod supporting the leaves passes through a block of unpolished ebonite or other good insulator, and the small disc on top may be removed if desired.

The electroscopes may be charged by touching a charged body to the knob, or by connecting it to the knob by a conducting wire. But sometimes it is more convenient to use a *proof-plane* (Fig. 464) which is simply a small metal disc on an insulating handle. This is touched to the charged body and then to the knob of the electroscopes.



FIG. 464.—A proof-plane.

446. Electrification by Induction. Let us slowly bring a rubbed ebonite rod towards the knob of the electroscopes. The

leaves are seen to separate even though the rod be a foot or more away. This experiment shows that the mere presence of an electrified body is sufficient to produce electrification in neighbouring conductors. The charge is said to be produced by *electrostatic influence* or *induction*. As soon as the charged body is removed the leaves collapse again.

This experiment also impresses the fact that an electrified body exerts an action on bodies in the space about it. This space is called its *electrical field of force*. It can be shown, too, that the magnitude of the force exerted depends on the material filling the space. For instance, if the electrified body is immersed in petroleum the force it exerts on another body is only about one half that in air. Indeed it is believed that the force exhibited is due to actions in the surrounding medium, which is known as the *dielectric*.

447. Nature of Induced Electrification. Let *A* and *B* (Fig. 465) be two metallic bodies placed near together on well-insulated supports.* Charge *A* positively by rubbing over it a glass rod rubbed with silk.

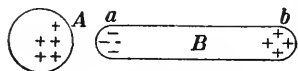

FIG. 465.—Explaining induced electrification.

First, touch *A* with a proof plane and carry it to the electroscope. The leaves will show a separation. Repeat and get a greater separation. Next, touch the proof plane to *a*, that end of *B* nearest *A*, and carry it to the electroscope. The leaves come closer together, showing that the charge on the end *a* is *negative*, that is, of the opposite kind to that on *A*.

Next, touch the proof-plane to the end *b*, which is farthest from *A*, and convey the charge to the electroscope. It makes the leaves diverge further, showing that the charge is of the same kind as that on *A*.

We find, therefore, that the two ends have charges of opposite signs, the charge on the end of *B* nearest to *A* being

*The bodies may be of wood covered with tin-foil, and may rest on blocks of paraffin.

of the opposite sign to that on *A*. It is to be observed, also, that the electrification on *B* does not in any way diminish the charge on *A*.

448. Induced Charges are Equal. Place two insulated conductors *A* and *B* in contact and hold a positively charged rod near (Fig. 466). The conductor *A* will be charged negatively and *B* positively. While the rod is in position separate the conductors, and then remove the rod. The body *A* is now charged with negative and *B* with positive electricity.

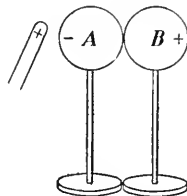

FIG. 466.—Two metal bodies on insulating stands. The charges on *A* and *B* are equal.

Bring them together carefully. A spark will be heard to pass between them and they will be entirely discharged. The two charges have neutralized each other, which shows that they must have been equal.

449. Charging by Induction. Let an electrified rod be brought near an insulated conductor (Fig. 467). A negative charge will be induced on the end *a* and a positive charge will be repelled to the end *b*. Suppose now the conductor is touched with the finger or is joined to earth*

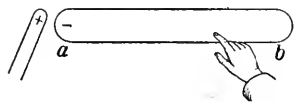

FIG. 467.—How to charge by induction.

by a wire (see § 455). We must now consider the conductor and the earth to be a single conductor, and while the negative charge will remain on *a*, “bound” to the charge on the rod the “free” positive charge will escape to the earth. Now remove the finger and then the rod. The conductor will be charged negatively.

In this way it is easy to give a charge of any desired kind and magnitude to an electroscope. Suppose we wish to give a positive charge. Rub an ebonite rod with cat’s fur

* Connect to a gas or water-pipe. Connection may be made to any part of the conductor.

and bring it towards the knob of the electroscope. The knob will be charged positively and the leaves negatively by induction. Now touch the electroscope rod with the finger; the negative charge will escape. Then remove the finger and after that the ebonite rod. The positive charge will remain on the electroscope, producing a separation of the leaves.

450. Charges Reside on the Outer Surface. Place a tall metal vessel on a good insulator (Fig. 468), and electrify it either by an ebonite rod or by an electrical machine (§ 461). Disconnect from the machine. Lower a metal ball, suspended by a silk thread, into the vessel and let it touch the inner surface. Then apply the ball to the electroscope; it shows no change.

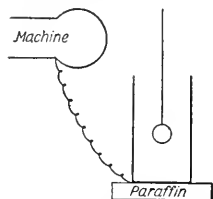

FIG. 468. — A tall metal vessel joined to an electrical machine. Removing the wire disconnects it.

Next, touch the ball to the outside of the vessel and test with the electroscope. It now shows a charge. Finally charge the ball by the machine, then lower it into the metal vessel and touch the inner surface with it. Then test it with the electroscope. It will be found that its charge is entirely gone; it was given to the metal vessel, on the outer surface of which it now is.

In Fig. 469 is shown a metal sphere on an insulating stand, and two hemispheres with insulating handles which just fit over it. First, charge the sphere as strongly as possible. Then, taking hold of the insulating handles, fit the hemispheres over it, and then remove them. If now the sphere is tested with the electroscope no trace of electricity will be found on it.

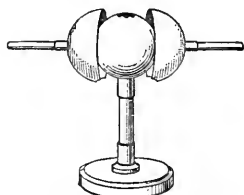

FIG. 469.—Apparatus to show that the charge resides only on the surface of a conductor.

451. Distribution of the Charge; the Action of Points. Though the electric charge resides only on the outer surface

of a conductor it is not always equally dense all over it. The distribution depends on the shape of the conductor, and experiment shows that the charge is greater at sharp edges.

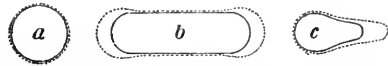

FIG. 470.—Showing the distribution of an electric charge on conductors of different shapes.

On a sphere the charge is uniformly distributed over the surface (*a*, Fig. 470). On a cylinder with rounded ends the charge is denser at the ends than at the middle (*b*, Fig. 470); and on a pear-shaped conductor it is much denser at the small end.

The force with which a charge tends to escape from a conductor increases with the density of the charge, and it is for

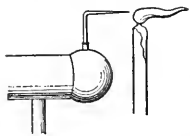

FIG. 471. — “Electric wind” from a pointed conductor blowing aside a candle flame.

this reason that a pointed conductor soon loses its charge. If a pointed wire is placed on a conductor attached to an electrical machine the electrified air particles streaming from it may blow aside a

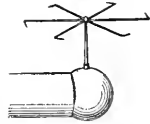

FIG. 472.—The “electric whirl” rotates by “the reaction from the electric wind.”

candle flame (Fig. 471); or an “electric whirl” (Fig. 472) nicely balanced on a sharp point when placed on an electrical machine is made to rotate by the reaction as the air-particles are pushed away from the points. It rotates like a lawn-sprinkler.

452. Lightning Rods. In a thunderstorm the clouds become charged with electricity and by induction a charge of the opposite sign appears on the surface of the earth just beneath. The points on the lightning rods, in the place where this charge is, allow the induced charge to escape quietly into the air. It is evident, then, that the lower end of a lightning rod should be buried deep enough to be in moist earth always, since dry earth is a poor conductor.

453. Electrical Potential. Let us take two insulated conductors A and B , two metal balls on silk threads, for instance, and let one of them be charged and the other not, or let one be charged to a greater degree than the other. Then when they are brought together there is some action between them, and we describe it by saying that there has been a *flow of electricity* from one to the other. We wish to learn on what this *flow depends*.

It can best be explained by considering analogies in other branches of science.

Water will flow from the tank A to the tank B (Fig. 473) through the pipe C connecting them if the water is at a higher level in A than in B ; or, what amounts to the same thing, if the hydrostatic pressure at a is greater than that at b . The tank B may already have more water in it, but the flow does not depend on that. It is regulated by the difference between the pressures at the two ends of the pipe and it will continue until these pressures become equal.

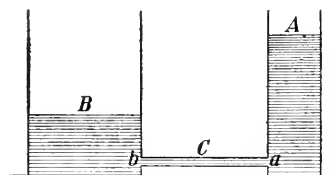

FIG. 473.—Water flows from the higher level in A to the lower level in B .

Or, consider what happens when two gas-bags filled with compressed air are joined by a tube in which is a stop-cock. If the pressure of the air is the same in each there will be no flow from one to the other on opening the stop-cock. If there is a difference, there will be a flow from the bag at high pressure to that at low.

Again, when two bodies at different temperatures are brought together, there is a flow of heat from the one at the higher temperature to that at the lower temperature.

Corresponding to pressure in hydrostatics and to temperature in the science of heat, in electricity we use the term

potential, (or sometimes *pressure*). If two points of a conductor are at different potentials there will be a flow from the point at high potential to that at low potential. This potential difference (for which *P.D.* is an abbreviation), is usually measured in *volts*, a definition of which will be given in the next chapter (§ 471).

454. Nature of Electricity. So far no reference has been made to the nature of electricity; indeed it is very difficult to make a hypothesis which will explain satisfactorily all the observed phenomena.

We speak of a *flow* of electricity, but certainly nothing of the nature of ordinary matter moves, though just as certainly there is a transference of energy. In the case of conduction of heat we do not know the precise nature of heat, but here again we are sure that there is a transference of energy.

But we have electricity of two kinds, which appear simply to neutralize each other. In considering the *flow of electricity* it is usual to confine our attention to the *positive* electricity. A flow of *negative* electricity in one direction in a conductor is equivalent to the flow of an equal amount of positive electricity in the opposite direction.

It is best, however, not to be too fixed in our views as to the precise nature of electricity, though we can be sure that when we say there is a flow of electricity, there is a transfer of energy. It is well to remember, too, that the electrical energy is not all within the conductor. On the other hand, it has been demonstrated that the energy resides chiefly in the surrounding space and that the conductor simply acts as a guide to it.

455. Zero of Potential. In stating levels or heights we usually refer them to the level of the sea. The ocean is so large that all the rain which it receives does not appreciably

alter its level. In a somewhat similar way, the earth is so large that all the electrical charges which we can give it do not appreciably alter its electrical level or potential, and so we take the earth to be our zero of potential.

Lake Superior is 602 feet above the level of the sea, and the Dead Sea, in Palestine, is 1,300 feet below it. There is a continual flow from Lake Superior to the ocean; and if a tube joined the two, there would be a flow from the ocean to the Dead Sea.

Bodies which are charged positively are considered to be at a potential higher than that of the earth, and those charged negatively to be at a potential below that of the earth.

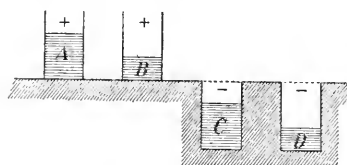

FIG. 474.—Four tanks with water at different levels.

Consider the four tanks in Fig. 474. The levels of *A* and *B* are above, and those of *C* and *D* below that of the earth. A

flow would take place from *A* or *B* to the earth, or from the earth to *C* or *D*, or from any one tank to another at lower level.

456. Electrical Capacity. On pouring the same quantity of water into different vessels we observe that it rises to different levels; and that vessel into which we must pour the most water in order to raise its level by any amount, say 1 cm., is said to have the greatest capacity. If a vessel has a small cross-section, like a narrow tube, it will not take much water to make a great change in its level; and its capacity is small.

There is something analogous in the science of electricity. It requires different amounts of electricity to raise the potentials of different conductors by one unit, and so we say there is a difference in the *electrical capacities* of conductors.

457. Electrical Condenser. In Fig. 475 *A* and *B* are two metal plates on insulating bases. They may be of tin-plate about 10 or 12 inches square, bent at the bottom and resting on paraffin blocks, *C, C*, with metal blocks *D, D*, to keep them in place. First let *B* be at some distance from *A*, and charge *A*. The greater the charge, the higher rises the potential and the wider diverge the gold-leaves. Continue charging until the leaves are far apart.

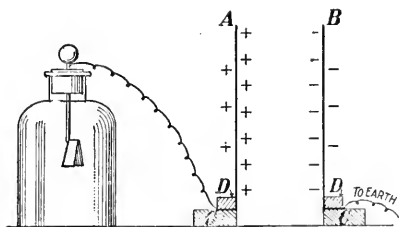

FIG. 475.—*A* and *B* are two metal plates on insulating bases. *A* is joined to an electroscope and *B* to earth.

Then, with the plate *B* joined to earth (simply keeping a finger on it will do), push it up towards *A*. As the plates get nearer together the leaves begin to fall, showing that the potential of *A* has fallen through the presence of *B*. If now we add positive electricity to *A* by means of a proof plane we shall find that several times the original amount of electricity must be added to *A* in order to obtain the original separation of the leaves, that is, to raise it to the original potential.

The two plates and the air between them constitute a *condenser*.

The explanation of the action of the condenser is as follows. Let the charge on *A* be positive. When the plate *B* is brought up the charge on *A* induces on *B* a negative charge repelling the equal positive charge to earth. The attraction of the charge on *B* draws the charge on *A* to the face nearest *B*, thus reducing the amount on the electroscope and making room for additional charges. The two charges on the plates *A* and *B* are "bound" charges.

458. The Dielectric in a Condenser. Push the plates *A* and *B* (Fig. 475) near together, and charge the plate *A* until the separation of the leaves is quite decided. Now insert between *A* and *B* a sheet of thick plate glass, sliding it along *B*, being careful not to touch *A*, and observe the effect on the electroscope. The leaves come closer together, showing that the potential has fallen and the capacity has increased. Ebonite or paraffin may be used as a dielectric instead of the glass, but the effect will not be so pronounced.

459. Leyden Jar. This is the most usual kind of condenser. It consists of a wide-mouthed bottle (Fig. 476), the sides and bottom of which, both within and without, are coated with tin-foil to within a short distance from the neck. The glass above the tin-foil is varnished to maintain the insulation. Through a wooden stopper passes a brass rod, the upper end of which carries a knob, the lower a chain which touches the inner coating of the jar. The two coatings form the two plates of the condenser, the glass being the dielectric.

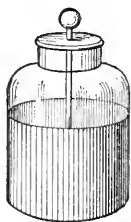

FIG. 476.—A Leyden Jar.

To charge the jar the outer coating is connected to earth (or held in the hand), and the knob is joined to an electrical machine. To discharge it, connection is made between the inner and outer coatings by discharging tongs (Fig. 477). Usually the discharge is accompanied by a brilliant spark and a loud report. (It is wisest not to pass the discharge through the body.)

Condensers used in electrical experiments are often made of a number of sheets of tin-foil separated from each other by sheets of paraffined paper or mica. Alternate sheets of the tin-foil are connected together.

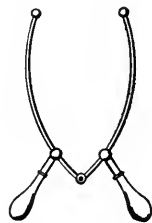

FIG. 477.—Discharging tongs. The handles are of glass or of ebonite.

460. The Electrophorus. By means of this instrument, which was invented by Volta, in 1775, we can electrify a conductor without using up its charge.

It consists of a cake *A* of ebonite or of resinous wax resting on a metal plate, and a metal cover* *B*, of rather smaller diameter, provided with an insulating handle. (Fig. 478.)

First, the cake is rubbed with cat's fur, and thus it obtains a negative charge. Then the cover is put on and touched with the finger. If it is lifted up by the handle it will be found to be positively charged, and on presenting it to the knuckle a spark, sometimes half-an-inch long, is obtained, and the cover is discharged. The gas may be lighted with this spark; and if the cover is presented to the knob of an electroscope the latter will be charged. The process may be repeated any number of times without renewing the charge on the cake.

QUERY.—Every time the cover is discharged energy disappears; where did it come from?

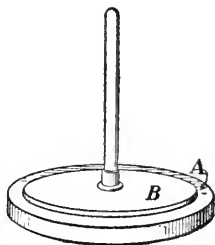

FIG. 478.—The electrophorus.

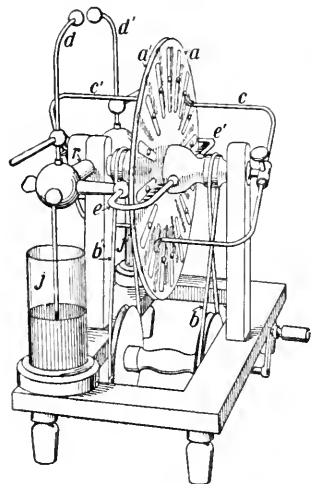

Fig. 479.—The Wimshurst electrical machine.

The action is explained thus:—When the cover is placed on the cake, which is a non-conductor, it rests upon it on a few points only and so does not remove its charge. But the negative charge on *A* induces on the lower face of *B* a “bound” positive charge, repelling to the upper face a “free” negative charge, which escapes when the finger touches it. When the cover is lifted the positive charge becomes “free” and spreads over its surface.

461. Wimshurst Influence Machine. The electrical machines in common use are simply convenient arrangements for utilizing the principle of influence so well illustrated in the electrophorus.

In Fig. 479 is shown a Wimshurst machine. It consists of two varnished glass plates *a*, *a'*, placed as close together as possible and driven by

* This may be a wooden disc covered with tin-foil.

belts b, b' in opposite directions. Each plate has an even number of metal sectors cemented on its outer face. A neutralizing conductor c, c' is fixed diametrically across each plate and fine wire brushes on the ends just touch the metal sectors as the plates rotate. These conductors are set almost at right angles to each other.

Two collecting combs e, e' with their teeth turned towards the rotating discs encircle them at each side of the machine. These are insulated from the frame of the machine by ebonite rods r, r' . From them run up a pair of adjustable discharging rods d, d' , ending in knobs. A pair of Leyden jars j, j' are usually added, and when these are charged a powerful spark passes.

462. Explanation of the Action of the Machine. The action of the machine can best be explained by a diagram (Fig. 480),

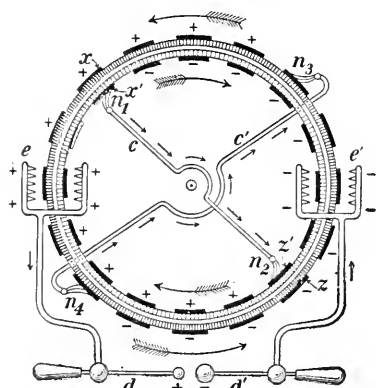

FIG. 480.—Diagram of a Wimshurst machine.

in which, for greater clearness, the two rotating discs are represented as though they were two cylinders of glass, one inside the other and rotating in opposite directions as shown by the arrows.* The neutralizing brushes n_1, n_2 touch the sectors on the back plate, while n_3, n_4 touch the front sectors. In the diagram a section of the cylinders is supposed to be seen, and the metal sectors are represented by the dark heavy lines on the outer and inner surfaces.

Suppose now that one of the sectors x on the front plate (near the top of the diagram) has a slight positive charge. As it rotates towards the left it will be brought opposite a sector x' on the back plate at the moment when this is in contact with the brush n_1 . This latter sector then acquires by influence a negative charge, the sector z' at the other end of c receiving a positive charge while the sector z opposite it, on the other plate, receives by influence a negative charge.

As the rotation continues the induced negative charges on x' and z are carried to the right hand comb e' by which they are collected, the positive charges on x and z' to the left-hand comb e , which collects them.

* This method of explanation is due to Prof. S. P. Thompson; see his *Elementary Lessons in Electricity and Magnetism*, p. 63.

Again, the negative charge on c' and the positive charge on z' are brought opposite n_3 and n_4 , respectively, and these are connected by c' . The sector which n_3 touches acquires a positive charge and that which n_4 touches acquires a negative charge, and these are carried on to the collecting combs.

In this way all the sectors become more and more highly charged, and the front sectors at the top and the back sectors at the bottom are carrying positive charges to the comb e , while the other sectors are carrying negative charges to the comb e' .

Thus large charges may be accumulated on the combs and in the jars connected with them (not shown in Fig. 480), and powerful sparks may be obtained between the knobs on the discharging rods d, d' .

CHAPTER XLIII

THE ELECTRIC CURRENT

463. Nature of the Electric Current. As explained in § 453, when two bodies at different potentials are joined by a conductor, there is a passage of electricity from one to the other, and this we speak of as an *electric current*.

The terms we use in dealing with electric currents are suggested by a study of the flow of liquids in pipes, but we must not push the analogy between the two cases too far. As to what electricity really is we are in entire ignorance. There may be no actual motion of anything through the conductor, though recent investigations somewhat favour that view, but since the current can do work for us we recognize the presence of energy.

464. An Electric Current Known by the Effects it will Produce. The electric current makes the conductor and the

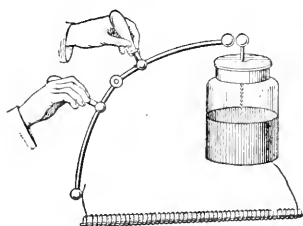

FIG. 481.—The pressure of an electric current shown by its power to magnetize steel.

region surrounding it acquire new properties, one of the most striking of these being a change in magnetic conditions. This is illustrated in the following experiment.

Insert an unmagnetized knitting needle into a small glass tube and wind copper wire in a coil about it. Connect one end of the wire with the outer coating of a powerfully charged Leyden jar, and the other with a discharger as shown in Fig. 481. Discharge the jar through the wire. On testing the knitting needle with a magnetic compass it will be found to be magnetized. Evidently the coil of wire in carrying the charge had the power to magnetize the steel.

465. The Voltaic Cell. The current in the wire connecting the two coatings of the Leyden jar lasts but for an instant, the

coatings almost at once assuming the same potential. In order to produce a continuous current a constant difference of potential must be maintained between the ends of the conductor. This can be done by means of the *Galvanic* or *Voltaic Cell*.

Galvani* discovered by accident that the discharge of an electric machine connected with a skinned frog produced convulsions in the legs; and on further research he found that the same effect could be produced without the electric machine, but simply by touching one end of a branched fork of copper and silver wires to the muscles in the frog's leg, and the other end to the lumbar nerves (Fig. 482). He attributed the result to "animal magnetism."



ALESSANDRO VOLTA (1745-1827). Professor of Physics at the University of Pavia, Italy. Invented the voltaic cell.

Volta, a fellow-countryman, conceived that the electric current had its origin, not in the frog's legs, but in the contact of the metals, and in a series of investigations he was led to the invention of the voltaic cell.

Volta divided conductors into two classes:—*First*, simple substances such as the metallic conductors, silver, copper, zinc, etc. *Second*, liquids such as dilute acids and solutions of metallic salts. These are now known as *electrolytes*, and are decomposed when an electric current

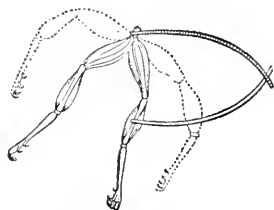

FIG. 482.—Galvani's experiment.

passes through them.

* Aloisio Galvani (1737-1798), a Physician and Professor of Anatomy in the University of Bologna.

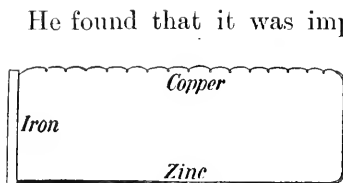

FIG. 483.—Conductors of the first class connected in a circuit; no current produced.

He found that it was impossible to produce a current by joining conductors of the first class in any order whatever in a circuit (Fig. 483); but that a current was developed whenever a conductor of the second class was introduced between two different conductors of the first class. For example, he found that when discs of copper and zinc were separated by a disc of cloth moistened with common salt brine, and joined externally by a conductor as in Fig. 484, a current passed through the circuit. Similarly he found that a current was generated when the plates thus connected were immersed in dilute sulphuric acid (Fig. 485). This combination is a voltaic cell in its simplest form.

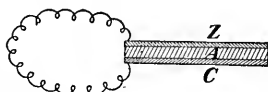

FIG. 484.—Conductors of the first and second classes connected in a circuit. Z, zinc; C, copper; A, cloth moistened with brine.

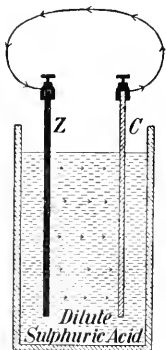

FIG. 485.—Simple voltaic cell.

The essential parts of an ordinary voltaic cell are two different conducting plates immersed in an electrolyte which acts chemically on one of them.

466. Plates of a Voltaic Cell Electrically Charged. Since an electric current flows through a conductor joining the plates of a voltaic cell, we would infer that the plates are electrically charged when disconnected. This can be shown to be the case by means of a *condensing electroscope*, which consists of an ordinary gold-leaf electroscope combined with a suitable condenser.

A convenient arrangement is illustrated in Fig. 486. It is unsatisfactory to work with a single voltaic cell. Three or four should be joined "in series" as shown at *B*. These cells may be small glass tubes

or bottles containing dilute sulphuric acid, with strips of copper and zinc soldered together and dipping in them. The condenser consists of two perfectly flat brass plates. The lower one *M* is supported on an ebonite stem, and the upper one *N* is furnished with a handle. A sheet of paraffined paper or dry writing paper or very thin mica is

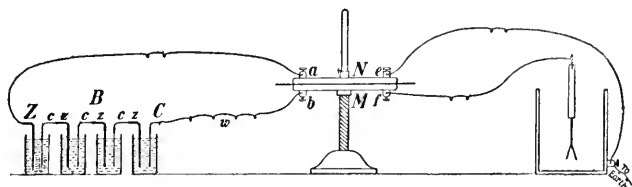

FIG. 436.—The condensing electroscope.

placed between the plates. The binding-posts *e* and *f* are joined to the electroscope, which is the same as shown in Fig. 463, with the disc removed. Its binding-post is joined to a gas-pipe or other good earth-connection. The end zinc plate *Z* of the battery is joined to *a* and the end copper plate *C* is joined loosely by the wire *w* to the binding post *b*.

When the connections have been made as described, there is a charge on the gold leaves, but it is so slight that they do not diverge appreciably.

Now by means of a glass or ebonite rod remove the wire *w* from the binding post *b*, and then lift off the upper plate *N* of the condenser. The leaves now diverge.

This action may be explained thus:—When the connections are as shown in the figure, *Z* and *N* are both joined to earth and hence are at zero potential. The lower plate *M* is charged positively by the battery. This charge attracts a *bound* negative charge to the lower face of *N*, repelling the corresponding *free* charge to earth. Thus there is a considerable charge of electricity in the condenser though the potential is not high.

But when w is removed and the plate N lifted the plate M is no longer a part of a condenser, but simply an isolated plate of much smaller capacity. The charge on it now being free, it spreads to the electroscope and causes the leaves to diverge.

In a voltaic cell the plate which is not attacked chemically is always found to have a positive charge, while the active plate is always found to have a negative charge.

467. An Electric Circuit — Explanation of Terms. A complete circuit is necessary for a steady flow of electricity. This circuit comprises the entire path traversed by the current, including the external conductor, the plates, and the electrolyte. The current is regarded as flowing from the copper to the zinc plate *in the external conductor*, and from the zinc to the copper plate *within the fluid* (Fig. 485).

When the plates are joined by a conductor, or a series of conductors, without a break, the cell is said to be *on a closed circuit*; when the circuit is interrupted at any point, the cell is *on an open circuit*. By joining together a number of cells a more powerful flow of electricity may be obtained, and such a combination is called a *battery*.

That plate of the cell or battery from which the current is led off is called the *positive pole*, the other the *negative pole*. Also, in an interrupted circuit, that end from which the current will flow when the connection is completed is said to be a positive pole or terminal, the other a negative pole or terminal.

468. Chemical Action of a Voltaic Cell. When plates of copper and pure zinc are placed in dilute sulphuric acid to form a voltaic cell, the zinc begins to dissolve in the acid, but the action is soon checked by a coating of hydrogen which gathers on its surface. If the upper ends of the plates are connected by a conducting wire, or are touched together, the zinc continues to dissolve in the acid, forming zinc sulphate, and hydrogen is liberated at the copper plate.

Commercial zinc will dissolve in the acid even when unconnected with another plate. The fact that the impure zinc wastes away in open circuit is possibly explained on the theory that the impurities, principally iron and carbon, take the place of the copper plate, and as a consequence currents are set up between the zinc and the impurities in electrical contact with it.

469. Source of Energy in the Cell. In order to produce a flow of electricity energy is required. The commonly accepted chemical theory of the action of a cell will be given in the next chapter; but for the present we may think of the cell as a kind of furnace in which zinc is burned up chemically in order to obtain electric energy.

When the circuit is open, just enough energy is exerted to keep the poles at a certain difference of electrical level or potential, but when the poles are connected by a conductor the current flows and the zinc is continually consumed.

470. Electromotive Force. The term ELECTROMOTIVE FORCE is applied to *that which tends to produce a transfer of electricity*. Consider, for example, a voltaic cell on an open circuit. Its electromotive force is its power of producing electric pressure, and this is obviously equal to the potential difference between the plates.

This conception can be illustrated by the analogy to two tanks of water maintained at different levels (Fig. 473). Just as the difference in level gives rise to a hydrostatic pressure which would cause a transfer of water if the tanks were connected by a pipe, so a difference of potential in the plates of the cell is regarded as producing an electrical pressure, or electromotive force, which would cause a transfer of electricity if the plates were connected by a conductor. (Read § 453 again.)

471. Unit of Electromotive Force. The difference of potential between two bodies is measured by the work done in transferring a certain quantity of electricity from one to

the other. The practical unit of potential difference, and hence of electromotive force (E.M.F.), is known as the *volt*, and this may be taken as approximately the E.M.F. of a zinc-copper cell.

472. Electromotive Force, Current Strength, and Resistance. The water analogy may assist us still further.

The strength of the water current, that is, the quantity of water which will flow past a point in the pipe in one second, obviously depends upon the pressure resulting from differences of level, and upon the resistance which the pipe offers to the flow of water. Similarly the *strength of the current* which passes through the conductor joining the plates of a cell *depends upon the electromotive force of the cell and the RESISTANCE of the circuit.*

The strength of the current may be increased, either by increasing the electromotive force, or reducing the resistance of the circuit. The exact relation between these quantities will be discussed at a later stage (§ 546).

473. The Electromotive Force of a Voltaic Cell. The E.M.F. of a cell containing a given electrolyte depends on the nature of the plates. Thus the E.M.F. of the zinc-carbon cell is about twice as great as that of the zinc-copper cell, when dilute sulphuric acid is the electrolyte.

When the materials used are constant, the E.M.F. is independent of the size and shape of the plates or their distance apart.

Theoretically, a comparatively large number of substances might be selected as plates to construct a voltaic cell. Consider, for example, the following elements in the order given:—

Magnesium | Zinc | Lead | Tin | Iron | Copper | Silver | Gold | Platinum | Carbon

If any two of these elements are used as plates in a voltaic cell the current will flow in the outer circuit from the second

to the first named. Moreover, the potential difference between any pair depends upon their distance apart in the series. Such a series is known as an *electromotive*, or *potential*, series.

474. Oersted's Experiment. We have referred to the fact that an electric current has the power of producing magnetic effects (§ 464). This important principle was discovered by Oersted* in 1819. In the course of some experiments made with the purpose of discovering an identity between electricity and magnetism, he chanced to bring the wire joining the plates of a voltaic battery over a magnetic needle, and was astonished to see the needle turn round and set itself almost at right angles to the wire.

On reversing the direction of the current the needle turned in the opposite direction (Fig. 487). If the battery is held over the wire the needle is deflected, thus showing that the current flows through the battery too.

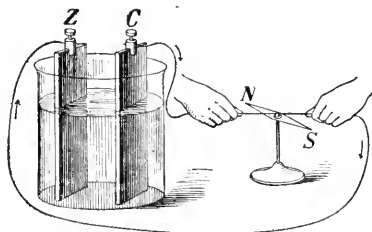

FIG. 487.—Oersted's experiment.

475. Detection of an Electric Current. Oersted's experiment furnishes a ready means of detecting an electric current. A feeble current, flowing in a single wire over a magnetic needle produces but a very slight deflection; but if the wire is wound into a coil, and the current made to pass several times in the same direction, either over or under the needle, or, better still, if it passes in one direction

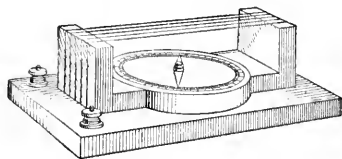

FIG. 488.—Simple galvanoscope. The wire passes several times around the frame, and its ends are joined to the binding-posts.

magnified (Fig. 488). Such an arrangement is called a *Galvanoscope*. It may be used not only to detect the presence of

* Hans Christian Oersted (1777-1851), Professor in the University of Copenhagen.

currents, but also to compare roughly their strengths, by noting the relative deflections produced.

476. Local Action. We have noted that a plate of commercial zinc dissolves when immersed in dilute acid, because electric currents are set up between the zinc and the impurities in electrical contact with it. Such currents are known as *local currents*, and the action is known as *local action*. This local action is wasteful. It may, to a great extent, be prevented by *amalgamating* the zinc. This is done by washing the plate in dilute sulphuric acid, and then rubbing mercury over its surface. The mercury dissolves the zinc, and forms a clean uniform layer of zinc amalgam about the plate. The zinc now dissolves only when the circuit is closed. As the zinc of the amalgam goes into the solution, the mercury takes up more of the zinc from within and the impurities float out into the liquid (see § 468). Thus a homogeneous surface remains always exposed to the acid.

477. Polarization of a Cell. If the plates of a zinc-copper cell are connected with a galvanoscope the current developed by the cell will be seen gradually to grow weaker. It will also be observed that the weakening in the current is accompanied by the collection of bubbles of hydrogen on the copper plate. To show that there is a connection between the change in the surface of the plate and the weakening in the current, brush away the bubbles and the current will be found to grow stronger. A cell is said to be *polarized* when the current becomes feeble from a deposition of a film of hydrogen on the plate forming the positive pole.

The adhesion of the hydrogen to the positive pole weakens the current in two ways. First, it decreases the potential difference between the plates; because the potential difference between zinc and hydrogen is much less than between zinc and copper or carbon. Second, it increases the resistance which

the current encounters within the cell, because it diminishes the surface of the plate in contact with the fluid.

Polarization may be reduced by surrounding the positive pole by a chemical agent which will combine with the hydrogen and prevent its appearance on the plate.

478. Varieties of Voltaic Cells. Voltaic cells differ from one another mainly in the remedies adopted to prevent polarization. Several of the forms commonly described have now only historic interest. Of the cells at present used for commercial purposes, the Leclanché, the Daniell, the Dry and the Edison-Lalande are among the most important.

479. Leclanché Cell. The construction of the cell is shown in Fig. 489. It consists of a zinc rod immersed in a solution of ammoniac chloride in an outer vessel, and a carbon plate surrounded by a mixture of small pieces of carbon and powdered manganese dioxide in an inner porous cup. The zinc dissolves in the ammoniac chloride solution, and the hydrogen which appears at the carbon plate is oxidized by the manganese dioxide.

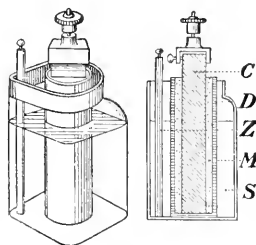

FIG. 489.—Leclanché cell. *C*, carbon; *D*, porous cup; *Z*, zinc; *M*, carbon and powdered manganese; *S*, solution of ammoniac chloride.

As the reduction of the manganese dioxide goes on very slowly, the cell soon becomes polarized, but it recovers itself when allowed to stand for a few minutes. If used intermittently for a minute or two at a time, the cell does not require renewing for months. For this reason it is especially adapted for use on electric bell and telephone circuits. Its E.M.F. is about 1.5 volts.

480. Daniell Cell. The Daniell cell consists of a copper plate immersed in a concentrated solution of copper sulphate

contained in an outer vessel and a zinc plate immersed in a zinc sulphate solution in an inner porous cup (Fig. 490).

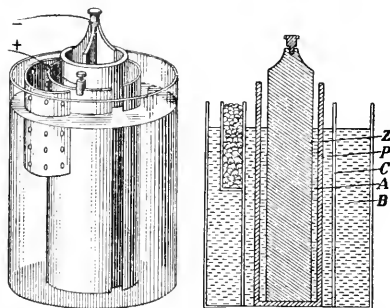

FIG. 490.—Daniell cell. *Z*, zinc; *P*, porous cup; *C*, copper; *A*, solution of zinc sulphate; *B*, solution of copper sulphate.

is placed at the bottom. The copper sulphate being denser than the zinc sulphate, sinks to the bottom, while the zinc sulphate floats above about the zinc plate. The copper sulphate solution is kept concentrated by placing crystals of the salt in a basket in the outer vessel (Fig. 490), or at the bottom about the copper plate (Fig. 491).

The Daniell cell is capable of giving a continuous current for an indefinite period if the materials are renewed at regular intervals; but the strength of the current is never very great because the internal resistance is high.

These cells are adapted for closed circuit work, when a comparatively weak current will suffice. The gravity type has been extensively used on telegraph lines, but in the larger installations the dynamo and the storage battery plants are now taking their place.

The E.M.F. of the cell is about 1.07 volts.

In a form of the Daniell cell known as the Gravity Cell the porous cup is dispensed with and the solutions are separated by gravity (Fig. 491). The zinc plate, which is usually of the form shown in the figure, is supported near the top of the vessel and the copper plate

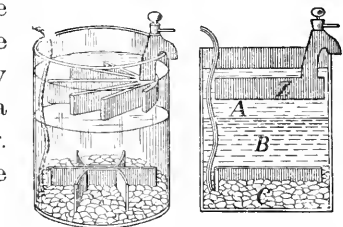

FIG. 491.—Gravity cell. *Z*, zinc plate; *A*, zinc sulphate solution; *B*, copper sulphate solution; *C*, crystals of copper sulphate.

481. The Dry Cell. The so-called *dry* cell is a modified form of the Leclanché cell. The carbon plate *C* (Fig. 492) is closely surrounded by a thick paste, *A*, composed chiefly of powdered carbon, manganese dioxide and ammonic chloride. This is all contained in a cylindrical zinc vessel, *Z*, which acts as the negative pole of the cell. Melted pitch, *P*, is poured on top in order to prevent evaporation, *i.e.*, to prevent the cell from becoming really *dry*.

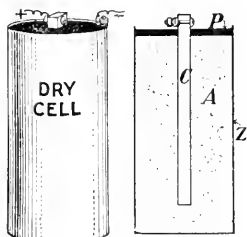

FIG. 492.—A dry cell.

482. Edison-Lalande Cell. In this cell one plate consists of compressed finely-ground copper oxide powder fitted in a light copper frame. On each side of this is a plate of zinc well amalgamated. The exciting liquid consists of one part of caustic soda dissolved in three parts by weight of water. To prevent it from being acted upon by the carbonic acid of the air it is covered with a layer of petroleum.

The E.M.F. is low, about 0.7 volt, but the internal resistance is also low; such a cell can deliver a powerful current (10 to 20 amperes) for a considerable time (15 to 30 hours).

QUESTIONS

1. The bichromate cell, once very commonly used in laboratories, consists of two connected carbon plates *C* and a zinc plate *Z* between them, immersed in a solution of potassium bichromate in water mixed with sulphuric acid *S*. (Fig. 493.) Explain the action of the cell.

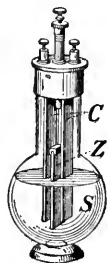

FIG. 493.—Bichromate cell.

2. The Grove cell, used before the dynamo was perfected, to furnish energetic constant currents, consists of a zinc plate immersed in dilute sulphuric acid and a platinum plate immersed in nitric acid, the fluids being kept apart by a porous cup. The Bunsen's cell differs from the Grove's cell in substituting a carbon plate for the platinum one. Explain the action of those cells.

CHAPTER XLIV

CHEMICAL EFFECTS OF THE ELECTRIC CURRENT

483. Electrolysis. In the preceding chapter we have discussed the production of an electric current through the action of an electrolyte on two dissimilar plates. If the action is reversed and a current from some external source is passed through an electrolyte, reactions similar to those within the voltaic cell take place. As an illustration take the action of an electric current

on hydrochloric acid. Connect the poles of a voltaic battery consisting of three or four cells to two carbon rods *A* and *B* (Fig. 494), and immerse these in the acid. The current flows in the direction indicated by

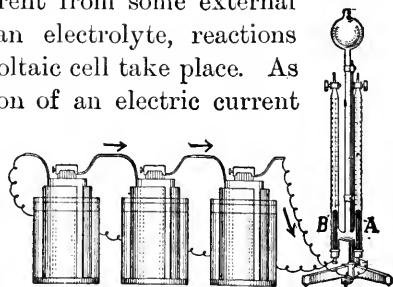

FIG. 494.—Electrolysis of hydrochloric acid. The electrodes *A* and *B* are carbon rods fitted in rubber stoppers.

the arrows, and the rod *A* by which it enters the electrolytic cell is called the *anode*, the rod *B* by which it leaves is called the *cathode*. *A* and *B* are spoken of as *electrodes*. Gases will collect at the electrodes. On testing, that liberated at *A* will be found to be chlorine, and that at *B*, hydrogen. This process of decomposition by the electric current is called *electrolysis* (*i.e.*, *electric analysis*).

484. Explanation of Electrolysis. According to the theory at present most commonly accepted, an electrolytic salt or acid, when in solution, becomes more or less completely dissociated. The respective parts into which the molecules divide are known as *ions*. When, for example, common salt is dissolved in water, a percentage of the molecules (NaCl)

break up to form sodium (Na) and chlorine (Cl) ions. Similarly, if sulphuric acid is diluted with water, some of its molecules (H_2SO_4) dissociate into hydrogen (H) ions and sulphion (SO_4) ions.

A definite charge of electricity is associated with each ion, and when it loses this charge it ceases to be an ion. The hydrogen and sodium atoms, and the atoms of metals in general, as ions, bear positive charges, while chlorine atoms and sulphion are types, respectively, of the elements and radicals which bear negative charges.

The ionization theory furnishes a simple explanation of the typical results described in the preceding section. When connected with the terminals of the battery the electrodes immersed in the hydrochloric acid become charged, the anode positively, and the cathode negatively. As a consequence, the positively charged hydrogen ions are attracted to the cathode, and the negatively charged chlorine ions to the anode. This 'migration' of positively charged ions in one direction, and negatively charged ions in the other, constitutes the current in the electrolyte.

The ions give up their charges to the electrodes, and combine to form molecules. The gases are, therefore, liberated at these centres.

The positive charges which the hydrogen ions bring to the cathode tend to diminish the negative charge of the cathode, while the negative charges of the chlorine tend to diminish the positive charge of the anode; but a constant difference of potential between the electrodes is kept up by the current maintained in the external conductor by the battery.

485. Theory of the Action of a Voltaic Cell. We have seen that chemical changes accompany the production of the current in the voltaic cell (§ 468). These take place in accordance with the same principles as the changes in the electrolytic cell as described in sections 483 and 484, the main difference being that in the electrolytic cell the source of the current is without the cell, while in

the voltaic cell the current originates within the cell itself. Various theories have been proposed to account for the cause of the current in the voltaic cell. Possibly the application of the ionization theory as proposed by Nernst gives the most plausible explanation of its origin.

According to this theory every metal immersed in an electrolyte has a certain pressure, known as its solution tension, tending to project its particles into solution in the form of ions. The magnitude of this pressure is the greater the nearer the metal to the positive limit in an electromotive series (§ 473). The metallic ions also have a tendency to give up their charges and to deposit themselves on metals immersed in the electrolyte, this tendency being the stronger the nearer the metal to the negative limit in an electromotive series. When the former of the forces is the stronger the solution about the metal in acquiring positive ions becomes positively charged in its relation to the metal. On the other hand, when the tendency of the ions to deposit themselves is the greater, an excess of deposition over solution takes place, and the metal in comparison with the solution becomes positively charged. In the first case the metal becomes lower in potential than the solution, and in the second case higher.

To apply this theory to the simple cell in which zinc and copper are the plates and dilute sulphuric acid is the electrolyte, consider first the zinc plate. Since zinc is near the positive limit in the electromotive series, the tension driving ions into solution is greater than the tendency towards deposition; hence zinc ions go into solution carrying positive charges. By experimental determination the zinc is found to be 0.62 volts lower in potential than the solution. Now consider the copper. As copper is towards the negative side of the series, the tendency of the ions to deposit themselves is the greater of the forces and the plate becomes positively charged by the deposition of positively charged hydrogen ions. The plate can be

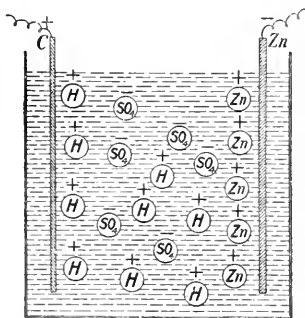

FIG. 495. — Diagram illustrating the theory of the action of a voltaic cell.

shown to be 0.46 volts higher in potential than the solution. The difference in potential, therefore, between the copper and zinc plates is $0.46 + 0.62 = 1.08$ volts.

When the poles are connected a current flows through the wire from the copper to the zinc, tending to discharge them; but, as rapidly as they are discharged the zinc throws more ions into solution and more hydrogen ions are forced against the copper, retaining a permanent difference of potential between the metals and producing a continuous flow of electricity until the zinc is all dissolved or the hydrogen ions all driven out of the electrolyte. The migration of positively charged ions towards the copper plate (cathode) and of the negatively charged ions towards the zinc plate (anode) constitute, as in the electrolytic cell, the current in the electrolyte.

486. Secondary Reactions in Electrolysis. If the hydrochloric acid is replaced by a solution of common salt (NaCl), chlorine as before appears at the anode; but the sodium atoms, which have parted with their charges to the cathode, instead of combining to form molecules, displace hydrogen atoms from molecules of water in order to form sodium hydroxide. Hence, hydrogen, and not sodium, is liberated at the cathode. The presence of the hydroxide in solution can be shown by adding sufficient red litmus to colour the solution. As soon as the current begins to pass, the liquid about the cathode is turned blue. The bleaching of the litmus about the anode indicates the presence of chlorine.

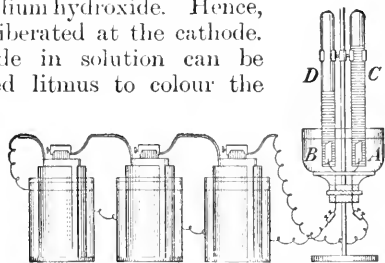

FIG. 496.—Electrolysis of water.

The above experiment is typical of a large number of cases of electrolytic decomposition where secondary reactions, depending on the chemical relations of elements involved, take place. The electrolysis of water, possibly, furnishes another example.

487. Electrolysis of Water. Insert platinum electrodes into the bottom of a vessel of the form shown in Fig. 496. Partially fill the vessel with water acidulated with a few drops of sulphuric acid. Fill two test tubes with acidulated water and invert them over the electrodes. Connect the electrodes with a battery of three or four voltaic cells. Gases will be seen to bubble up from the electrodes, displacing the water in the test tubes.

On testing each gas with a lighted splinter, that collected at the anode will be found to be oxygen, and that at the cathode, hydrogen. It will also be observed that the volume of the hydrogen collected is twice that of the oxygen.

In this case, as in the electrolysis of hydrochloric acid, there is a migration of hydrogen ions in the direction of the current, and the gas is given off at the cathode; but the liberation of the oxygen is probably due to secondary reactions. The sulphion (SO_4) ions move to the anode, where they part with their charges and combine with the hydrogen of the water, thus forming again sulphuric acid, and liberating oxygen. The quantity of the acid, therefore, remains unchanged and water only is decomposed.

488. Electroplating. Advantage is taken of the deposition of a metal from a salt by electrolysis in order to cover one metal with a layer of another, the process being known as *electroplating*.

Consider, as an example, the process of silver-plating. The objects to be plated are immersed in a bath containing a

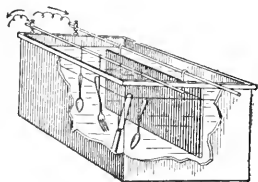

FIG. 497.—Bath and electrical connection for electroplating.

solution of a silver salt, usually the cyanide (AgCN). A plate of silver is also immersed in the bath (Fig. 497). A current from a battery or dynamo is then passed through the bath, from the silver plate (the anode), to the objects (the cathode). The positively charged silver ions are urged to the objects, and on giving up their charges, are deposited as a metallic film upon them. Meanwhile the negatively charged cyanogen (CN) ions migrate towards the silver plate, from which they attract into solution additional silver ions. Thus the metal is transferred from the plate to the objects, while the strength of the solution remains constant.

The process of plating with other metals is similar to silver-plating. The electrolyte must always be a solution

of the salt of the metal to be decomposed; the anode is a plate of that metal, and the cathode the object to be plated.

For copper-plating, the bath is usually a solution of copper sulphate; for gold- and silver-plating, a solution of the cyanides; and for nickel-plating, a solution of the double sulphate of nickel and ammonium.

489. Electrotyping. Books are now usually printed from *electrotype* plates instead of from type, as the type would soon wear away. An impression of the type is made in a wax mould, the face of which is then covered with powdered plumbago to provide a conducting surface upon which the metal can be deposited. The mould is then flowed with a solution of copper sulphate, and iron filings are sprinkled over it. The iron displaces copper from the sulphate, and the plumbago surface is thus covered with a thin film of copper. The iron filings are washed off, and the mould immersed in a bath of nearly concentrated copper sulphate solution, slightly acidulated with sulphuric acid. The copper surface is then connected with the negative pole of a battery or dynamo, and a copper plate which is connected with the positive pole is immersed in the bath.

When the layer of copper has become sufficiently thick it is removed from the bath, backed with melted type-metal and mounted on a wooden block. The face is an exact reproduction of the type or engraving.

490. Electrolytic Reduction of Ores; Electrolysis Applied to Manufactures. Electrolytic processes are now extensively used for reducing certain metals from their ores. A soluble, or fusible salt is formed by the action of chemical reagents, and the metal is deposited from it by electrolysis. For example, aluminium is reduced in large quantities from a fused mixture of electrolytes. Sodium is prepared in a similar manner.

The metallurgist also resorts to electrolysis in separating metals from their impurities. Copper, for example, is refined in this way.

The unrefined copper is made the anode in a bath of copper sulphate, and the pure copper is deposited at the cathode, while the impurities fall to the bottom of the bath.

Currents of electricity are also employed in the preparation of many chemical products for commercial purposes. Caustic soda and bleaching liquors are manufactured on a large scale by electrolytic means.

491. Polarization of Electrodes. If, in the process of the decomposition of water (§ 487), we disconnect the wires from the battery when the gases are coming off freely, and connect them

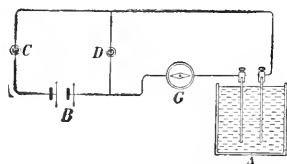

FIG. 498.—Electric connection in an experiment to illustrate the polarization of electrodes.

with a galvanoscope, we shall find that a current will flow in a direction opposite to that which liberated the hydrogen and oxygen. The experiment may be readily performed by connecting the battery *B*, the electrolytic cell *A*, and

the galvanoscope *G*, as shown in Fig. 498, mercury cups or keys being provided for opening and closing the circuits at *C* and *D*. When the circuit is closed at *C* but open at *D* the electrolysis proceeds, and the galvanoscope indicates the direction of the current. If the battery is cut out by opening *C*, and the circuit is closed at *D*, a momentary current is found to pass in a direction opposite to the original current.

The reverse current is explained on the principle that the films of hydrogen and oxygen which collect about the electrodes cause a difference in potential between them, which develops an E.M.F. in a direction opposite to that which produced the original current. The electrodes are then said to be *polarized*.

It is obvious that to decompose water, the E.M.F. of the battery used must be greater than the counter-electromotive

force, which is about 1.47 volts, set up by the difference in potential between the electrodes when the gases are being liberated.

492. Storage Cells or Accumulators. If lead electrodes are substituted for the platinum in the experiment of the preceding section, and the battery current is made to pass through dilute sulphuric acid (1 of acid to 10 of water) for a few minutes, hydrogen will be liberated as before at the cathode, and the other lead plate, the anode, will be observed to turn a dark brown, but no oxygen will be set free at its surface.

On cutting out the battery by opening the circuit at *C*, and connecting the lead plates with the galvanoscope by closing the circuit at *D*, a reverse current, much stronger than that generated by the polarization of the platinum electrodes, will pass through the galvanoscope. Moreover, this current will last much longer.

This experiment illustrates the principle of action of all *storage cells* or *accumulators*.

When the current is passed through the dilute acid from one plate to the other, the oxygen freed at the anode unites with the lead, forming oxide of lead. The composition of the anode is thus made to differ from the cathode, and in consequence there arises a difference in potential between them which causes a current to flow in the opposite direction when the plates are joined by a conductor.

This current will continue to flow until the plates again become alike in composition, and hence in potential.

493. Construction of Lead Cell and Edison Cell. Instead of using plates of solid lead, perforated plates or "grids" made of lead, or some alloy of lead, are frequently employed. The holes in the plates are filled with a paste of lead oxides (red lead on the positive, litharge on the negative plate), which forms the active

material (Fig. 499). When the plates are immersed in the dilute sulphuric acid and the current passed through the cell, these oxides are changed to peroxide (PbO_2) in the positive plates and reduced to spongy lead in the negative.

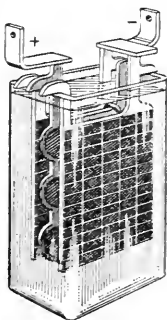

FIG. 499.—A storage cell, with one positive and two negative plates. Two positive and three negative, three positive and four negative, or even more plates may be used.

During the process of discharge both the plates are converted into lead sulphate, and a part of the sulphuric acid disappears, thus lowering the density of the electrolyte. When the cell is being charged, the sulphurion ions combine with lead sulphate and water to form the lead peroxide and sulphuric acid, and the hydrogen ions react upon the lead sulphate forming spongy lead and sulphuric acid.

In the Edison storage battery, which has recently obtained some prominence, the positive plate consists of perforated steel tubes heavily nickel-plated, filled with alternate layers of nickel hydroxide and pure metallic nickel in very thin flakes. The negative plate is a grid of nickel-plated steel holding a number of rectangular pockets filled with powdered iron oxide. The electrolyte is a 21 per cent. solution of caustic potash in distilled water, with a small percentage of lithia. The battery jar is made from nickel-plated steel. Its voltage is 1.2 and it weighs about one-half as much as a lead battery of equal capacity.

494. Laws of Electrolysis. Faraday discovered the LAWS OF ELECTROLYSIS and formulated them in 1833. They may be summed up in the following statements:—

1. *The amount of an ion liberated at an electrode in a given time is proportional to the strength of the current.*

2. *The weights of the elements separated from the electrolyte by the same electric current are in the proportion of their chemical equivalents.*

495. Measurement of Current Strength by Electrolysis. In accordance with the laws of electrolysis the amount of the ions liberated per unit time may be taken as an exact measure of the strength of a current passing through an electrolyte.

The practical unit of current strength is called the *ampere* and is defined as *the current which deposits silver at the rate of 0.001118 grams per second* (see § 547).

The same current deposits copper at the rate of 0.000328 grams, and hydrogen at the rate of 0.000010384 grams per second.

Other elements may be used in defining the unit, but in practice when the strength of a current is to be estimated by electrolysis, it is usually determined by ascertaining the amount of silver, copper, or hydrogen which is deposited in a specified time. If W_1 , W_2 , W_3 is the mass in grams of silver, copper and hydrogen, respectively, deposited in t seconds, and C the strength of the current in amperes. Then

$$C = \frac{W_1}{t \times 0.001118} = \frac{W_2}{t \times 0.000328} = \frac{W_3}{t \times 0.000010384}$$

496. Voltameters. An electrolytic cell used for the purpose of measuring the strength of an electric current is called a *voltmeter*.

For silver, the cell consists of a platinum bowl, partially filled with a solution of silver nitrate in which is suspended a silver disc (Fig. 500). When the voltmeter is placed in the circuit, the platinum bowl is made the cathode and the silver disc the anode. When the current has been passed through the solution for the specified time the silver disc is removed, the solution poured off, and the bowl washed, dried and weighed. The increase in weight gives the mass deposited.

The copper voltmeter consists of two copper electrodes immersed in a solution of copper sulphate. The cathode is weighed before and after the passing of the current. The difference in weight gives the amount of copper deposited in the given time.

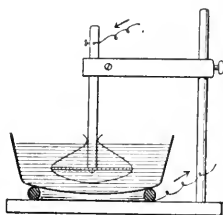

FIG. 500.—A standard silver voltmeter. Cathode, a platinum bowl not less than 6 cm. in diameter and 4 cm. deep. It rests on a metal ring to ensure good connection. Anode, a disc of pure silver supported by a silver rod riveted through its centre. Electrolyte, 15 parts by weight of silver nitrate to 85 parts of water. Filter paper is wrapped about the anode to prevent loose particles of silver from falling on the cathode.

The hydrogen, or water, voltameter is simply the apparatus used for the decomposition of water (§ 487). For the purpose of measuring the current, the hydrogen alone is collected in a graduated tube. The current to be measured is passed through the acidulated water until the liquid in the tube stands at the same level as the liquid in the vessel. The time during which the current was passing is then noted. The temperature of the gas and the barometric pressure are also taken. The volume of the hydrogen liberated is read from the graduated tube, reduced to standard pressure and temperature, and the mass corresponding to this volume calculated.

The process of measuring the strength of a current by a voltameter is slow. We shall discuss in the next chapter a more convenient method by the use of galvanometers. Voltameters are now used mainly in standardizing these instruments.

QUESTIONS AND PROBLEMS

1. Why can a single Daniell cell not be used to decompose water?
2. Plates of copper and platinum are dipped into a solution of copper sulphate, and a current is passed through the cell from the copper to the platinum. Describe the effects produced, also what happens when the current is reversed.
3. How long will it take a current of one ampere to deposit one gram of copper from a solution of copper sulphate?
4. A constant current is passed through a silver voltameter for a period of 20 minutes and it is found that 6.708 grams of silver have been deposited. What is the strength of the current?
5. The same current is passed through three electrolytic cells, the first containing acidulated water, the second a solution of copper sulphate, and the third a solution of silver nitrate. What weight of hydrogen and what weight of oxygen will be liberated at the first cell; and what weight of copper will be deposited at the cathode of the second cell; when 11.18 grams of silver are deposited on the cathode of the third cell?
6. What transformations of energy take place (1) in charging a storage cell, (2) in discharging it? Is anything "stored up" in the cell? If so, what?
7. Why is it possible to get a much stronger current from a storage cell than from a Daniell cell?

CHAPTER XLV

MAGNETIC RELATIONS OF THE CURRENT

497. Discovery of Electromagnetic Phenomena. The discovery by Oersted of the effect of an electric current on the magnetic needle (§ 474) gave a decided impetus to the study of electromagnetic phenomena. The investigations of Arago, Ampère, Davy, Faraday and others during the next ten years led to the discovery of practically all the principles that have had important applications in modern electrical development.

498. Magnetic Field Due to an Electric Current. In 1820, a year after Oersted's great discovery, Arago proved that a wire carrying a strong current had the power to lift iron filings, and hence concluded that such a wire must be regarded as a magnet. Two years later Davy showed that the apparent attraction was due to the fact that the particles of iron became magnets under the influence of the current, and that on account of the mutual attractions of the opposite poles they formed chains about the wire.

The action of the current on the filings may be shown by

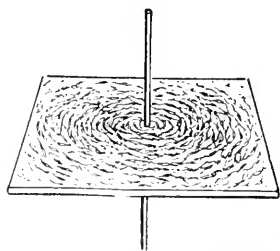

FIG. 501.—The presence of a magnetic field about a wire carrying an electric current shown by action on iron filings.

passing a thick wire vertically up through a hole in a card, and sprinkling iron filings from a muslin bag on the card. If the card is gently tapped while a strong current is passing through the wire, the filings arrange themselves in concentric rings

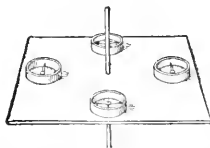

FIG. 502.—The presence of a magnetic field about a wire carrying an electric current shown by the action on a compass needle.

about it. (Fig. 501.)

If a small jeweler's compass is placed on the card, and moved from point to point about the wire, it is found that in every position the needle tends to set itself with its axis tangent to a circle whose

centre is the wire (Fig. 502). On reversing the direction of the current the direction in which the needle points is also reversed.

These experiments show that *a wire through which an electric current is flowing is surrounded by a magnetic field, the lines of force of which form circles around it.* Thus the wire throughout its entire length is surrounded by a "sort of enveloping magnetic whirl."

The direction in which a pole of the magnetic needle tends to turn depends on the direction of the current in the wire. Several rules for remembering the relation between the direction of the current and the behaviour of the needle have been given, two of them being as follows:—

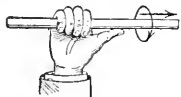

FIG. 503.—Direction of lines of force about a conductor.

1. *Suppose the right hand to grasp the wire carrying the current (Fig. 503) so that the thumb points in the direction of its flow; then the N-pole will be urged in the direction in which the fingers point.*

2. *Imagine a man swimming in the wire WITH the current and that he turns so as to face the needle; then the N-pole of the needle will be deflected towards his LEFT hand.*

499. Magnetic Field about a Circular Conductor.

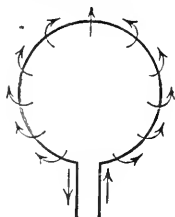

FIG. 504.—Lines of force about a circular loop.

Since the lines of force encircle a conductor, it would appear that a wire in the form of a circular loop, carrying a current (Fig. 504) should act as a disc of steel magnetized so as to have one face a *N*-pole, the other a *S*-pole. That such is the case can be demonstrated by a simple experiment. Take a piece of copper wire and bend it into the

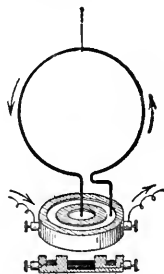

FIG. 505.—Experiment to show that a circular loop carrying a current behaves as a disc magnet.

form shown in Fig. 505, making the circle about 20 cm. in diameter. Suspend the wire by a long thread, and allow its ends to dip into mercury held in receptacles made in a wooden block of the form shown in the figure. (The inner receptacle should be about 2 cm. in diameter and the outer one 2 cm. wide with a space of 1 cm. of wood between them.) Pass a current through the circular conductor by connecting the poles of a battery with the mercury in the receptacles. For convenience in making connections, the receptacles should be connected by iron wires with binding posts screwed into the block.

Now, if a bar-magnet is brought near the face of the loop, the latter will be attracted or repelled by its poles, and behave in every way as if it were a flat magnetic disc with poles at its faces. Indeed, if the current is strong, and the ends of the wire moves freely in the mercury, it will set itself with its faces north and south under the influence of the earth's magnetic field.

In taking this position it obeys the general law that a magnet when placed in the field of force of another magnet always tends to set itself in such a position that the line joining its poles will be parallel to the lines of force of the field in which it is placed.

To fulfil this condition the plane of the coil must become perpendicular to the direction of the lines of force of the field. *A coil carrying a current, therefore, always tends to set itself in the position in which the maximum number of lines of force will pass through it.*

500. Magnetic Conditions of a Helix. Ampère showed that the magnetic power of a wire carrying a current could be intensified by winding it into the form of a spiral. The magnetic properties of such a coil can be demonstrated by simple experiments.

Make a helix, or coil of wire, about three inches long, by winding insulated copper wire (No. 16 or 18) about a

lead-pencil. Connect the ends of the wire with the poles of a voltaic cell, and with a magnetic needle explore the region surrounding it.

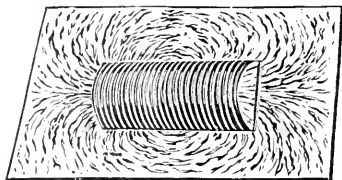

FIG. 506.—A helix carrying a current behaves like a bar-magnet.

Next make a helix somewhat larger in diameter, say about three-quarters of an inch, and place it in a rectangular opening made in a sheet of cardboard (Fig. 506). This can be done by cutting out two sides and an end of a rectangle of the proper size and then passing the free end of the strip lengthwise through the helix, and replacing the strip in position. Sprinkle iron filings from a muslin bag on the cardboard around the helix and within it. Attach the ends of the wire to the poles of a battery and gently tap the cardboard.

In these experiments the helix through which the current is passing behaves exactly like a magnet, having *N* and *S* poles and a neutral equatorial region. The field, as shown by the action of the needle and the iron filings, resembles that of a bar-magnet. (Compare § 429.)

501. Polarity of the Helix and Direction of the Current.

There is a fixed relation between the poles of the coil and the direction of the current passing through the wire. *Looking at the south pole of the helix, the electric current passes through the coils in the direction of the hands of a clock* (Fig. 507); or, we can give a “right-

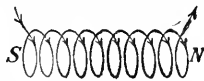

FIG. 507.—Relation of polarity of helix to the direction of the current—clock rule.

hand” rule similar to that in § 498 as follows:—*If the helix is grasped in the right hand, as shown in Fig. 508, with the fingers pointing in the direction in which the current is moving in the coils, the thumb will point to the N-pole.*

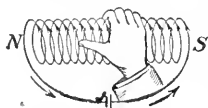

FIG. 508.—Relation of polarity of helix to direction of current—right-hand rule.

502. Electromagnet. Arago and Ampère magnetized steel needles by placing them within a coil of wire carrying a current. Sturgeon, in 1825, was the first to show that if a core of soft-iron is introduced into such a coil (Fig. 509) the magnetic effect is increased, and that the core loses its magnetism when the circuit is opened. The combination of the helix of insulated wire and a soft-iron core is called an *electromagnet*.

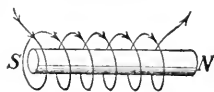

FIG. 509.—The essential parts of an electromagnet.

503. Why an Electromagnet is More Powerful than a Helix without a Core. When the helix is used without a core, the greater number of the lines of force pass in circles around the individual turns of wire, comparatively few running through the helix from end to end and back again outside the coil; but when the iron core is inserted the greater number of lines of force pass in this latter way, because the permeability of iron is very much greater than that of air. Whenever a turn of wire is near the core, the lines of force, instead of passing in closed curves around the wire, change their shape and pass from end to end of the core. The effect of the core, therefore, is to increase the number of lines of force which are concentrated at the different poles, and consequently to increase the power of the magnet.

The strength of the magnet may be still further increased

by bringing the poles close together so that the lines of force may pass within iron throughout their whole course. This is done either by bending the core into horse-shoe form, as shown in

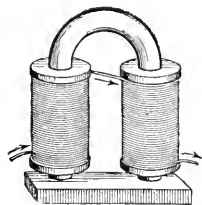

FIG. 510.—An electromagnet—horse-shoe form.

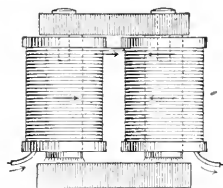

FIG. 511.—An electromagnet—yoke form.

Fig. 510, or by joining two magnets by a 'yoke' as shown in

Fig. 511. The lines of force thus pass from one pole to the other through the iron body held against them.

504. Strength of an Electromagnet. The strength of an electromagnet depends equally on the strength of the current and on the number of turns of wire which encircle the core.



ANDRÉ MARIE AMPÈRE (1775-1836). Born at Lyons, France. Discovered the action of one current upon another.

This law is generally expressed by saying that the strength is proportional to the *ampere-turns* which surround the core, meaning that the strength varies as the product of the number of turns of wire about the core and the strength of the current measured in amperes.

This law is true only when the iron core is not near to being magnetized to saturation.

It should also be observed that when an electromagnet is used with a battery, or other source of current where the ends of the wire are kept at a constant difference of potential, an increase in the number of turns of the wire may not necessarily add to the strength of the magnet, because the loss in magnetizing force through loss in current caused by increased resistance may more than counterbalance the gain through the increased number of turns of wire.

QUERY.—In what circuit should a “long coil” electromagnet (one with a great number of turns of fine wire) be used,—one in which the remaining resistance is great or small as compared with the resistance of the magnet? (See § 510.)

505. Action of one Electric Current on Another.—Ampère's Laws. Oersted's discovery of the action of an electric current on the magnetic needle (§ 474) led Ampère to investigate the actions of currents on one another. The results of his observations are formulated in two statements, generally known as AMPÈRE'S LAWS.

1. *Parallel currents in the same direction attract each other; parallel currents in opposite directions repel each other.*

2. *Angular currents tend to become parallel and to flow in the same direction.*

The laws may be verified in a simple manner by the following experiments:—

Wind insulated magnet wire (No. 20) into coils of the forms *A* and *B* in Fig. 512. *A* is about 25 cm. square and contains five convolutions of wire. It may be made by winding the wire around the edge of a square board, tying the strands together at a number of points with thread, and removing the board. *B* may be made in a similar manner. It is rectangular, 20 cm. by 10 cm. and contains also five convolutions.

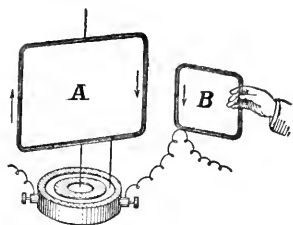

FIG. 512.—Apparatus and connection for demonstrating Ampère's Laws. Parallel currents in the same direction attract each other.

Suspend *A* by a long thread and allow the ends of the wire to dip into the mercury receptacles, as shown in Fig. 505. Connect the wires as shown in Fig. 512 so that a current from a battery of three or four cells will pass in one continuous current through the two coils.

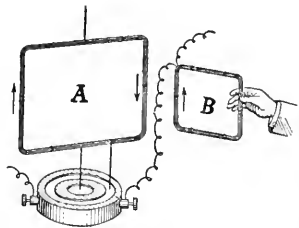

FIG. 513.—Connection for demonstrating Ampère's Laws. Parallel currents in opposite directions repel each other.

Bring one edge of *B* near one of the vertical edges of *A* with the planes of the coils at right angles to each other, in such a position that the current in the adjacent portions of the two coils will flow (1) in the same direction (Fig. 512); (2) in the opposite direction (Fig. 513).

In the first position the coils attract each other and in the second they repel each other.

Now, hold *B* within *A* as shown in Fig. 514, arranging the connecting wires in such a way that *A* is free to turn round.

The coil *A* turns about and tends to set itself in the

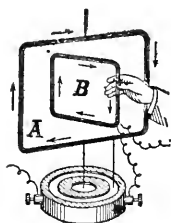

FIG. 514.—Connections for demonstrating Ampère's Laws. Angular currents tend to become parallel and flow in the same direction.

position in which the currents are parallel and flow in the same direction.

The reason for the behaviour of the coils is obvious. When the currents flow in the same direction, their magnetic fields tend to merge, and the action in the medium which surrounds the wires tends to draw them together, but when the currents flow in opposite directions

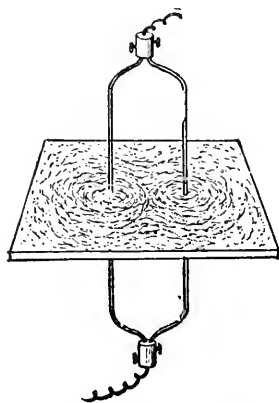

FIG. 515.—Magnetic field of two currents in the same direction.

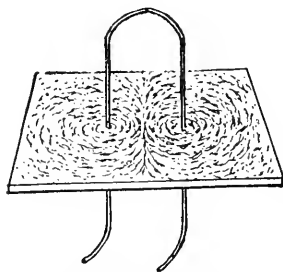

FIG. 516.—Magnetic field of currents in opposite directions.

these actions tend to push the wires further apart (see § 499). The directions of the lines of force in the fields may be shown by passing two wires through the card as in the experiment of § 498, and causing the current to pass (1) in the same direction through each wire (Fig. 515); (2) in opposite directions (Fig. 516).

506. Practical Applications of the Magnetic Effects of the Current. No sooner were the principles of electromagnetism made known by the researches of the early investigators than their practical applications began to be recognized.

Schweigger modified Oersted's experiment by bending the wires in coils about the magnetic needle, and applied the device to detecting electric currents and comparing their strengths.

Ampère, in 1821, suggested the possibility of transmitting signals by electromagnetic action. Joseph Henry used an electromagnet at Albany, in 1831, for producing audible signals. In 1837, Morse devised the system by which dots and dashes, representing letters of the alphabet, were made on a strip of moving paper by the action of an electromagnet. About the same period, also, the possibility of producing rotary motion by the action of electromagnets was demonstrated by the experiments of Henry, Jacobi, Davenport, and others. At the present time electromagnets are used for a great variety of practical purposes. The following sections contain descriptions of some of the more common applications.

507. The Electric Telegraph. The electric telegraph in its simplest form is an electromagnet operated at a distance by a battery and connecting wires. The circuit is opened and closed by a *key*. The electromagnet, fitted to give signals, is called a *sounder*. When the current in the circuit is not sufficiently strong, on account of the resistance of the line, to work a sounder, a more sensitive electromagnet called a *relay* is introduced which closes a local circuit containing a battery directly connected with the sounder.

508. The Telegraph Key. The key is an instrument for closing and breaking the circuit. Fig. 517 shows its construction. Two platinum contact points, *P*, are connected with the binding posts *A* and *B*, the lower one being connected by the bolt *C* which is insulated from the frame, and the upper one being mounted on the lever *L* which is connected with the binding post *B* by means of the frame. The key is placed in the circuit by connecting the ends of the wire to the binding posts.

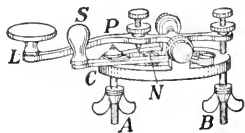

FIG. 517.—Telegraph key.

When the lever is pressed down, the platinum points are brought into contact and the circuit is completed. When the

lever is not depressed, a spring N keeps the points apart. A switch S is used to connect the binding posts, and close the circuit when the instrument is not in use.

509. The Telegraph Sounder. Fig. 518 shows the construction of the sounder. It consists of an electromagnet, E , above the poles of which is a soft-iron armature A , mounted on a pivoted beam B . The beam is raised and the armature held by a spring S , above the poles of the magnet at a distance regulated by the screws C and D . The ends of the wire of the magnet are connected with the binding posts.

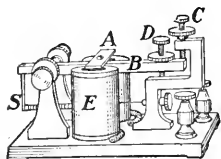

FIG. 518.—Telegraph sounder.

510. The Telegraph Relay. The relay is an instrument for closing automatically a local circuit in an office, when the current in the main circuit, on account of the great resistance of the line, is too weak to work the sounder. It is a key worked by an electromagnet instead of by hand. Fig. 519 shows its construction. It consists of a "long coil" electromagnet R , in front of the poles of which is a pivoted lever L carrying a soft-iron armature, which is held a little distance from the poles by the spring S . Platinum contact points, P , are connected with the lever L and the screw C . The ends of the wire of the electromagnet are connected with the binding posts B, B , and the lever L and the screw C are electrically connected with the binding posts B_1, B_1 .

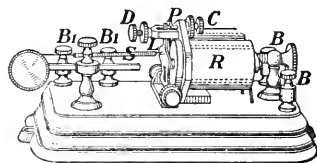

FIG. 519.—Telegraph relay.

Whenever the magnet R is magnetized the armature is drawn toward the poles and the contact points P are brought together and the local circuit completed.

511. Connection of Instruments in a Telegraph System.

Fig. 520 shows a telegraph line passing through three offices

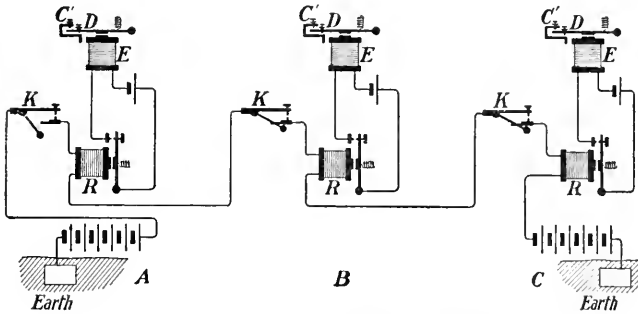

Fig. 520.—Connection of instruments in a telegraph circuit.

A, B, and C, and indicates how the connections are made in each office.

When the line is not in use the switch on each key *K* is closed and the current in the main circuit flows from the positive pole of the main battery at A, across the switches of the keys, and through the electromagnets of the relays, to the negative pole of the main battery at C, and thence through the battery to the ground, which forms the return circuit, to the negative pole of the main battery at A. The magnets *R*, *R*, *R*, are magnetized, the local circuits completed by the relays, and the current from each local battery flows through the magnet *E* of the sounder.

When the line is being used by an operator in any office A, the switch of his key is opened. The circuit is thus broken and the armature of the relay and of the sounder in each of the offices is released.

When the operator depresses the key and completes the main circuit, the armature of the relay in each office is drawn in, and the local circuit is completed. The screw *D* of each sounder is then drawn down against the frame, producing a 'click.' When he breaks the circuit at the key, the local

circuit is again opened and the beam of each sounder is drawn up by the spring against the screw *C*, producing another 'click' of different sound. If the circuit is completed and broken quickly by the operator, the two 'clicks' are very close together, and a "dot" is formed; but if an interval intervenes between the 'clicks' the effect is called a "dash." Different combinations of dots and dashes form different letters. The transmitting operator at *A* is thus able to make himself understood by the receiving operator at *B* or *C*.

512. The Electric Bell.

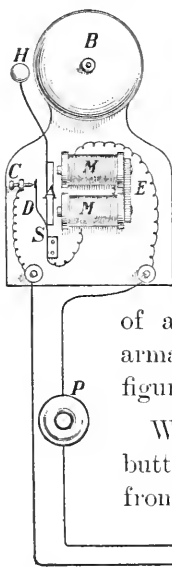
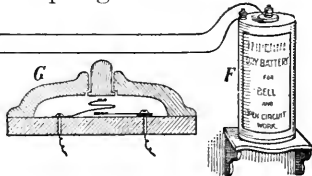

Fig. 521 shows the construction of one of the most common forms. It consists of an electromagnet *M, M, E*, in front of the poles of which is supported an armature *A* by a spring *S*. At the end of the armature is attached a hammer *H*, placed in such a position that it will strike a bell *B* when the armature is drawn to the poles of the magnet. A current breaker, consisting of a platinum-tipped spring *D*, attached to the armature, is placed in the circuit as shown in the figure.

When the circuit is completed by a push-button *P*, the current from the battery passes from the screw *C* to spring *D* and

FIG. 521.—Electric bell and its connections. At *G* is shown a section of the push-button. The figure shows the bell when the button is not pressed. The current may pass in either direction through the bell.



through the electromagnet to the battery. The armature is drawn in and the bell struck by the hammer; but by the

movement of the armature the spring *D* is separated from the screw *C*, and the circuit is broken at this point. The magnet then released, the armature with its spring *S* causes the hammer to fall back into its original position when the circuit is again completed. The action goes on as before and a continuous ringing is thus kept up.

513. Galvanometers. Since the magnetic effect of the current varies as its strength, the strengths of different currents may be compared by comparing their magnetic actions. Instruments for this purpose are called *Galvanometers*. There are two main types of the instrument.

In the first type the strength of the current is measured by the deflection of a magnetic needle within a fixed coil, made to carry the current to be measured; in the second, the strength is measured by the deflection of a movable coil suspended between the poles of a permanent magnet.

The Galvanoscope described in § 475 is of the first type.

514. The Tangent Galvanometer. A more useful instrument of the first type is the *tangent galvanometer*. It consists of a short magnetic needle, not exceeding one inch in length, suspended, or poised at the centre of a large open ring or circular coil of copper wire not less than ten inches in diameter. A light pointer is usually attached to the needle, and its deflection is read on a circular scale placed under the pointer (Fig. 522).

This is called a 'tangent' galvanometer because when the coil is placed parallel with the earth's magnetic meridian and a current passed through it the

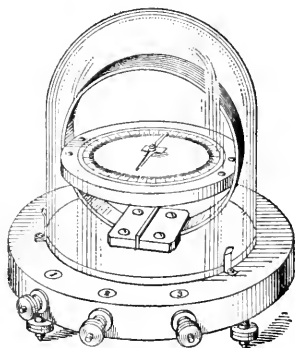

FIG. 522.—Tangent galvanometer.

intensity of the current will vary as the 'tangent' of the angle of deflection of the needle.

Thus, if the current corresponding to any angle of deflection, say one ampere, is known, the current corresponding to any other angle of deflection can be determined by referring to a table for the tangent of the angle, and making the necessary calculations.

515. The D'Arsonval Galvanometer. Galvanometers of the second type are generally known as *D'Arsonval galvanometers*.

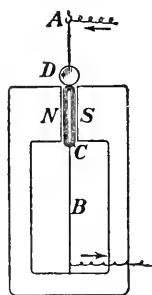

FIG. 523. — The essential parts of a D'Arsonval galvanometer.

In this form the permanent magnet remains stationary, and a suspended coil rotates through the action of the current in the field of the permanent magnet. Fig. 523 shows the essential parts of the instrument, and in Fig. 527 a complete instrument is seen. *N* and *S* are the poles of a permanent magnet of the horse-shoe type. *C* is an elongated coil suspended by the wires *A* and *B*, which lead the current to and from the coil. The deflection of the coil is indicated either by a light pointer and a

scale, or by a mirror *D* attached to the upper part of the coil to reflect a beam of light, which serves as a pointer to indicate the extent of the rotation.

The coil is brought to the zero by the torsion of the suspension wires. When the current is passed through it, the coil tends to turn in such a position as to include as many as possible of the lines of force of the field of the permanent magnet, and the deflection is approximately proportional to the strength of the current. Instruments of this type may be made exceedingly sensitive.

516. Ammeters and Voltmeters. A galvanometer with a scale graduated to read amperes is called an *ammeter*. The

coils are of low resistance, in order that the instrument may be placed directly in the circuit without sensibly affecting the strength of the current.

If the galvanometer is to be used to measure potential differences between points in a circuit it should have high resistance (why?); and if the scale is graduated to read directly in *volts*, the instrument is called a *voltmeter*.

The best portable voltmeters and ammeters used for commercial purposes are of the movable coil type. Fig. 524 shows an instrument of this class. The coil *C*, having a soft-iron cylinder within it, is pivoted on jewel bearings, and is held between the poles *N* and *S* of a permanent magnet of great constancy. It is brought to the zero position by a coil spring *sp*.

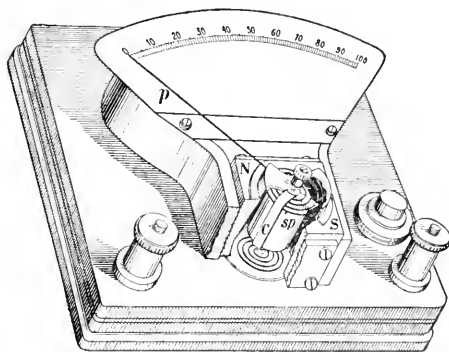

FIG. 524.—Ammeter or voltmeter. *C*, movable coil; *sp*, one of the springs; *N*, *S*, poles of the permanent magnet; *p*, pointer.

When the current is passed through the instrument, the coil, to which a pointer *p* is attached, reacts against the spring and turns about within the field of the magnet.

Each instrument is calibrated by comparison with a standard instrument placed simultaneously in the same circuit with it.

QUESTIONS

1. If you were given a voltaic cell, wire with an insulating covering, and a bar of soft-iron, one end of which was marked, state exactly what arrangements you would make in order to magnetize the iron so that the marked end might be a *N*-pole. Give diagram.

2. A current is flowing through a rigid copper rod. How would you place a small piece of iron wire with respect to it so that the iron may be magnetized in the direction of its length? Assuming the direction of the current, state which end of the wire will be a *N*-pole.

3. A telegraph wire runs north and south along the magnetic meridian. A magnetic needle free to turn in all directions is placed over the wire. How will this needle act when a current is sent through the wire from south to north? Supposing the wire to run east and west, how would you detect the direction of the current with a magnetic needle?

4. An insulated wire is wound round a wooden cylinder from one end *A* to the other end *B*. How would you wind it back from *B* to *A* (1) so as to increase, (2) so as to diminish, the magnetic effects which it produces when a current is passed through it? Illustrate your answer by a diagram drawn on the assumption that you are looking at the end *B*.

5. A small coil is suspended between the poles of a powerful horse-shoe magnet, and a current is made to flow through it. How will the coil behave (1) when its axis is in the line joining the poles of the magnet? (2) when it points at right angles to that line?

6. If it were true that the earth's magnetism is due to currents traversing the earth's surface, show what would be their general direction.

7. An elastic spiral wire hangs so that its lower end just dips into a vessel of mercury. When the top of the spiral is connected with one pole of a battery, and the mercury with the other, it vibrates, alternately breaking and closing the circuit at the point of contact of the end of the wire and the mercury. Explain this action.

CHAPTER XLVI

INDUCED CURRENTS

517. Faraday's Experiments. Much of the life of the great investigator Faraday was occupied in endeavours to trace relations between the various "forces of nature,"—gravitation, chemical affinity, heat, light, electricity and magnetism. Seeing that magnetic effects could be produced by an electric current, he felt sure that an electric current could be obtained by means of a magnet. During seven years (1824-31), he devoted considerable time to securing experimental proof of this, and at last, in August, 1831, was successful.

He took a ring of soft-iron and on it wound two coils *A*, *B*, of wire. The ends of one coil he joined to the terminals of a battery *C*, the ends of the other to a galvanometer *G* (Fig. 525). He noticed that

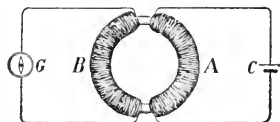

FIG. 525.—Current induced in a circuit by opening or closing another circuit.

on closing the battery circuit the needle of the galvanometer was deflected, but that after oscillating a while it returned again to its zero. However, just when the circuit was opened the needle was again deflected, settling down to rest as before after a few oscillations.

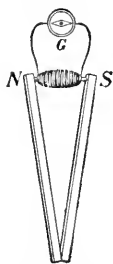

FIG. 526.—Current induced in a circuit by moving it within the field of a permanent magnet.

On September 23rd he wrote, "I am busy just now again on electromagnetism, and think I have got hold of a good thing, but can't say. It may be a weed instead of a fish that I may at last pull up." The following day he placed a coil of wire wound over an iron core, with its ends connected to a galvanometer, between the poles of bar-magnets as shown in Fig. 526. Whenever the magnetic contact at *N* and *S* was made or broken the needle of the galvanometer *G* was disturbed.

On October 1st he again modified his experiments by winding two coils of insulated wire on the same block of wood, connecting one with the galvanometer, and the other with the battery. As before, he found that whenever the battery circuit was closed or opened a current was produced in the galvanometer circuit, and that the needle was deflected in one direction on closing the circuit, in the opposite on opening it; but that in this case, as in his previous experiments, the current in the galvanometer circuit was only momentary.

It remained only to invent a method of making these momentary currents continuous. This has been worked out by others and has given us the dynamo. Thus, in the discovery of the principle of producing a current by induction, Faraday made possible all the modern applications of electricity in industrial development.

518. Production of Induced Currents. Faraday's discoveries may be summed up in the following statement:—*Whenever, from any cause, the number of magnetic lines of force passing through a closed circuit is changed, an electric current is produced in that circuit.*

Such a current is known as an *induced current*.

519. Illustrations of Induced Currents. Faraday's original experiments are simple and can be performed by anyone without difficulty. The coils connected with the galvanometer should be wound with many turns of fine insulated wire, and the galvanometer used should be sensitive; one of the D'Arsonval (§ 515) type answers well.

A great variety of experiments might be added to illustrate the phenomena of induced currents, because any device whatever which will alter the number of lines of force passing through a coil will induce a current in it.

Let us take a coil of very fine insulated wire wound on a hollow spool of the form shown in Fig. 527 and connect the ends of the wire to the galvanometer. Thrust the pole of a bar-magnet into it, and then withdraw it; slip the coil over one pole of a horse-shoe magnet, and then remove it. In both cases the galvanometer indicates a current, in one direction when the pole passes within the coil, and in the opposite direction when it is withdrawn, but in each case *the current lasts only while the magnet and coil are in motion relative to each other.*

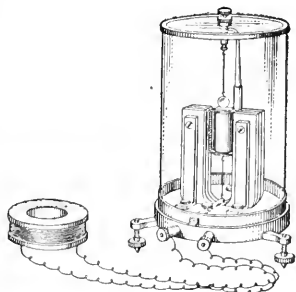

FIG. 527.—Apparatus for showing that when a magnet is thrust into or withdrawn from a closed coil a current is induced in the coil.

If the coil used in the preceding experiments is slipped over the pole of an electromagnet connected with a battery, as shown in Fig. 528 and then withdrawn, effects similar to those observed in the case of the permanent magnet will be seen.

520. Explanation of Terms.

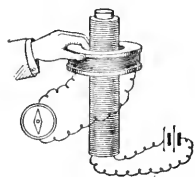

FIG. 528.—Currents induced in a closed coil by moving it in the field of an electromagnet.

The coil connected with the battery is called the *primary coil*, and the current which flows through it is called the *primary current*; the coil connected with the galvanometer is called the *secondary coil*, and the momentary currents made to flow in it, *secondary currents*. When the secondary currents flow in the same direction as the primary, they are said to be *direct*, or to flow in a *positive direction*;

but when the secondary currents flow in the opposite direction, they are said to be *inverse*, or to flow in a *negative direction*.

521. Laws of Induced Currents. Let us repeat the last experiment, and take care to trace the relative directions of the primary and secondary currents when the number of magnetic lines of force passing through the space inclosed by the secondary coil is (a) increasing, (b) decreasing. It will be found that *whenever a DECREASE in the number of lines of force which pass through a closed circuit takes place, a current is induced in this circuit, flowing in the same direction as that which would be required to produce this magnetic field, that is, a DIRECT current is produced; and that whenever an INCREASE in the number of lines of force takes place, the current induced is such as would by itself produce a field opposite in direction to that acting, that is, an INVERSE current is produced.*

Remember therefore,

A decrease gives a *direct* current,

An increase gives an *inverse* current.

Also, by moving the coil up to the pole of the magnet, at one time rapidly, and at another slowly, and observing the effects on the galvanometer of the change in the rate of the motion, it has been shown that *the total electromotive force induced in any circuit at a given instant, is equal to the time-rate of the variation of the flow of magnetic lines of force through that circuit.*

It is evident that when a circuit is not closed it is impossible to produce a current in it by a change in the number of lines of force which pass through it; but it should be observed that, as in the case of a voltaic cell in open circuit, a potential difference is established between the terminals of the conductor. In other words, an electromotive force is developed in the circuit.

It should be noted, also, that the *motion* of a conductor within a magnetic field does not necessarily develop an

E.M.F. in it. It does so only when it cuts the lines of force, and it is obvious that it does not do so when the conductor is moved in the direction parallel with the lines of force of the field. This may be shown by connecting the coil used in the previous experiments with the galvanometer and moving it in various directions about the poles of a horse-shoe magnet. The needle is undisturbed when the coil is moved to and fro between the poles, in the position shown in Fig. 529; but if the coil is moved up and down, or placed between the poles and turned about a horizontal or a vertical axis, or moved in any other way which causes *the number of lines of force passing through it to change*, a current is generated.

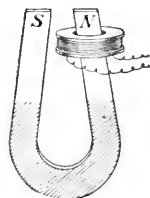

FIG. 529.—Change in the number of lines of force cutting a coil necessary to the production of induced currents.

522. Lenz's Law. We have found (*a*) that parallel currents in the same direction attract each other (§ 505), (*b*) that on moving a current *from* a conducting circuit an induced current is produced in the secondary in the same direction as the primary, (§ 521). We have also found (*a*) that parallel currents in opposite directions repel each other, and (*b*) that on moving a current *towards* a conducting circuit an induced current is produced in the secondary in the opposite direction to that in the primary.

Hence, in all cases of electromagnetic induction, *the direction of the induced current is always such that it produces a magnetic field which opposes the motion or change which induces the current.* This is known as LENZ'S LAW.

523. Self-Induction. If an electromagnet containing many turns of wire is connected with a battery and the circuit closed and opened by touching the two ends of the connecting wires together and then separating them, a spark will be observed at the ends of the wires when they are separated,

and if the hands are in contact with the bare wires, a shock will possibly be felt.

The effects observed are due to what is known as *self-induction*.

We have seen that, in the case of two distinct coils of wire near each other, when a current is started or stopped in one a current is induced in the other. This is due to the fact that the number of magnetic lines of force passing through the second coil is thereby altered. But we can have this inductive effect with a single coil. Each turn of the wire of the coil will exert an inductive action on all the other turns.

The magnetic lines of force surrounding a current, in circulating around a wire, pass, especially when the wire is coiled, across contiguous parts of the same circuit, and any variation in the strength of the current causes the current to act inductively on itself. On completing the circuit, this current is inverse; and on breaking it, direct.

The direct induced current in the primary wire itself, which tends to strengthen the current when the circuit is broken, is called the *extra current*.

This self-induced current is of high E.M.F., and therefore jumps across the air space as the wires are separated, thus producing the spark.

QUESTIONS

1. You have a metal hoop. By means of a diagram describe some arrangement by which, without touching the hoop, you can make electric currents pass around it, first one way, and then the other.
2. A coil about one foot in diameter, made of 400 or 500 turns of fine insulated wire, is connected with a sensitive galvanometer. When it is held with its plane facing north and south, and then turned over quickly, the needle of the galvanometer is disturbed. Give the reason for this.
3. A bar of perfectly soft-iron is thrust into the interior of a coil of wire whose terminals are connected with a galvanometer. An induced current is observed. Could the coil and bar be placed in such a position that the above action might nearly or entirely disappear? Explain fully.

4. Around the outside of a deep cylindrical jar are coiled two separate pieces of fine silk-covered wire, each consisting of many turns. The ends of one coil are joined to a battery, those of the other to a sensitive galvanometer. When an iron bar is thrust into the jar a momentary current is observed in the galvanometer coils, and when it is drawn out another momentary current (but in an opposite direction) is observed. Account for these results.

5. A small battery was joined in circuit with a coil of fine wire and a galvanometer, in which the current was found to produce a steady but small deflection. An unmagnetized iron bar was now plunged into the hollow of the coil and then withdrawn. The galvanometer needle was observed to recede momentarily from its first position, then to return and to swing beyond it with a wider arc than before, and finally to settle down to its original deflection. Explain these actions, and state what was the source of the energy that moved the needle.

6. The poles of a voltaic battery are connected with two mercury cups. These cups are connected successively by :—(1) A long straight wire. (2) The same wire arranged in a close spiral, the wire being covered with some insulating material. (3) The same wire coiled around a soft-iron core. Describe and discuss what happens in each case when the circuit is broken.

CHAPTER XLVII

APPLICATIONS OF INDUCED CURRENTS

524. The Principle of the Dynamo. In its simplest form, a dynamo is a coil of wire rotated about an axis in a magnetic field. The principle may be illustrated by connecting to the galvanometer the coil used in the experiments on current induction and rotating it about a vertical axis between the poles of a horse-shoe magnet. Continuous rotation in one direction is prevented by the twisting of the connecting wires about each other. In a working dynamo this difficulty is overcome by joining the ends of the wires to rings, from

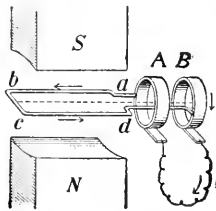

FIG. 530.—Principle of the dynamo.

which the current is taken by brushes bearing upon them. A study of Figs. 530-533 will show how the current is generated in the coil and how it is made to flow from

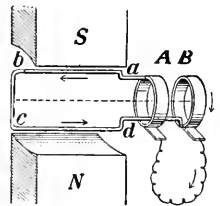

FIG. 531.—Principle of the dynamo.

brush to brush through the external conductor.

Let *abcd* be a coil of wire, having one end attached to the ring *A* and the other to the ring *B*; and suppose the coil to rotate about a horizontal axis between the poles *N* and *S*.

Now the maximum number of lines of force pass through the coil when it is in the position shown in Fig. 530 and 532, and the minimum number when it is in the position shown in Figs. 531 and 533. In the first quarter-turn, that is, in the change from the position shown in Fig. 530 to the position shown in Fig. 531, the number of lines of force passing through the coil is decreasing, and a direct current (flowing clockwise viewed from *N*) is induced in it. During the next

quarter-turn (Figs. 531 and 532) the number of lines of force through the coil is increasing, and an inverse current (counter-

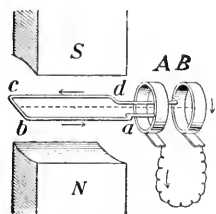

Fig. 532.—Principle of the dynamo.

clockwise viewed from N) is induced in it; but as the opposite face of the coil (viewed from N) is presented to the view, it is evident that the current flows in the same

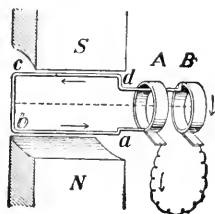

Fig. 533.—Principle of the dynamo.

absolute direction in the coil as during the first quarter-turn. In the same way it can be shown that the current continues to flow in one direction in the coil during the second half-turn (Figs. 532, 533, 531). But as the sides ab and cd of the coil have changed places, this direction will be opposite to that of the current in the coil during the first half-turn. The current in the coil, therefore, changes direction at the end of each half revolution, but the complete circuit includes the wires joining the brushes bearing on A and B ; hence a current which changes direction at regular intervals is produced in the external conductor. Such is known as an *alternating current*.

525. The Armature of the Dynamo. We have, for simplicity, considered in the preceding section the case of the revolution of a single coil within the magnetic field. In ordinary practice a number of coils are connected to the same collecting rings or plates. These coils are wound about a soft-iron core, which serves to hold them in place and to increase the number of lines of force passing through the space inclosed by them. The coils and core with the attached connections constitute the *armature* of the dynamo.

The armatures vary in type with the form of the core and the winding of the coils. A single coil wound in a groove about a soft-iron cylinder (Fig. 534) forms a *shuttle* armature; when a number of coils are similarly wound about the same

iron cylinder the armature is said to be of the *drum* type. Fig. 535 shows a *Gramme-ring* armature, in which a series of coils are wound about an iron ring. To prevent the generation of "eddy currents," within the iron itself, which are waste-

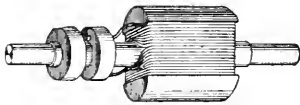

FIG. 534.—Shuttle armature.

ful of energy and

overheat the machine, the armature core is built up of thin soft-iron discs insulated from one another.

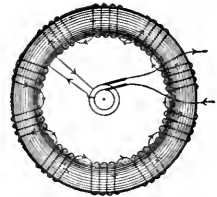

FIG. 535.—Gramme-ring armature. (Invented by Gramme in 1868.)

526. Field Magnets. In small generators, used to develop

high tension (or potential) currents, permanent magnets are sometimes used to supply the fields. The machine is then called a *magneto*. In all ordinary dynamos the field is furnished

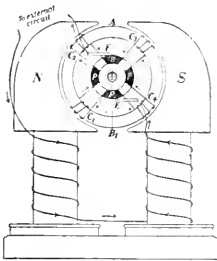

FIG. 536.—Bipolar field.

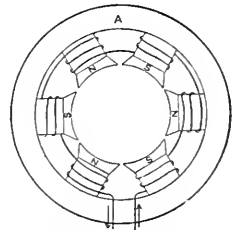

FIG. 537.—Multipolar field.

by electromagnets known technically as *field-magnets*. These magnets are either bipolar (Fig. 536) or multipolar (Fig. 537). In the multipolar type two or more pairs of poles are arranged in a ring about a circular yoke *A*.

527. The Alternating Current Dynamo. When an alternating current is used for electric lighting or power transmission, the alternations range from 25 to 60 per second. Now such a current cannot be generated in a bipolar field except by unduly increasing the rapidity of the revolutions of the armature, because the current changes direction but twice each revolution. The requisite number of alternations is secured by increasing the number of pole-pieces in the

field-magnets. In the alternators in common use, the armature coils A, A, \dots (Fig. 538) revolve in a multipolar field. They are wound in alternate directions and connected in series with the two free ends of the wire brought to two collecting rings, C and D , as shown in the figure.

To study the action, suppose the ring of armature coils to be opposite to the ring of the field coils, and to be revolving in either direction. Since the armature coils leaving positions

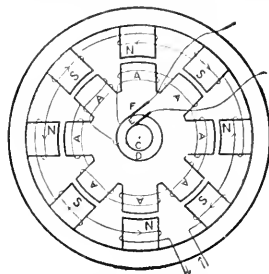

FIG. 538. — Essential parts and electrical connections in the alternating current dynamo.

opposite N -poles in the field have currents induced in them opposite in direction to those in the coils leaving S -poles, and since these coils are wound alternately to the right and the left, it is evident that the induced current in each coil will be in such a direction as to produce a continuous current in the whole series, which will flow from one collecting ring to the other. It is evident, also, that the direction of this current will be reversed the instant the field and armature coils again face each other.

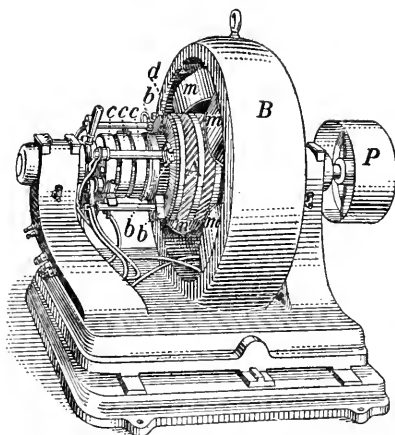

FIG. 539. — A self-exciting alternating current dynamo, driven by the pulley P . There are four field-magnets, m, m, m, m , connected by the yoke B . A is the armature. In this case it really consists of two armatures wound together. One is joined to a commutator d , on which rest four brushes b, b, b (one not seen). This generates a direct current (see next section) which is used to excite the field-magnets. The other armature is joined to the three collecting rings c, c, c , from which the three-phase alternating current is led off.

each revolution of the armature equals the number of poles in

the field-magnet, the number of alternations per minute is equal to the number of poles in the field-magnet multiplied by the number of revolutions made by the armature per minute.

528. Production of a Direct Current—The Commutator.

When an electric current flows continuously in one direction it is said to be a *direct* current. The current in an armature coil changes direction, as we have seen, at regular periods. To produce a direct current with a dynamo it is necessary to provide a device for commuting the alternating into a direct current. This is done by means of a *commutator*. It consists of a collecting ring made of segments called *commutator plates*, or *bars*, insulated from one another. The terminals of the coils are connected in order with the successive plates of the ring. Take, for example, the case of a single coil revolved in a bipolar field, as considered in (§ 524). The

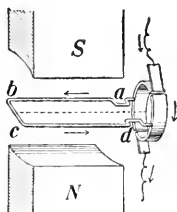

FIG. 540.

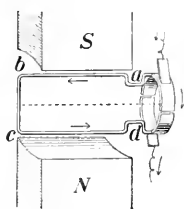

FIG. 541.

Arrangements for transforming the alternating current in the armature into a direct current in the external circuit.

commutator consists of two semi-circular plates, (Figs. 540 and 541), and the brushes are so placed that they rest upon the insulating material between the plates at the instant the current is changing direction in the coil. Then since the commutator plates

change position every time the current changes direction in the coil, the current always flows in the same direction from brush to brush in the external circuit.

529. Direct Current Dynamo. The essential parts of a direct current dynamo with 'ring' armature and bipolar field are shown in Fig. 542. The coils are wound continuously in one direction about the core, and are connected with commutator

plates P, P, \dots as indicated. For simplicity, suppose that the ring contains but four coils, C_1, C_2, C_3, C_4 , and that they are in the typical positions shown in the figure.

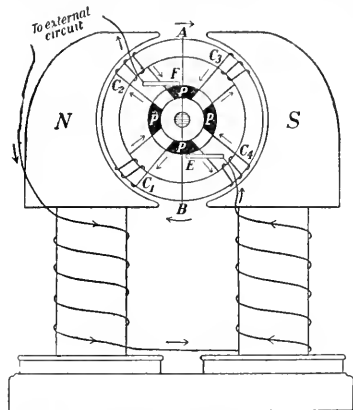

FIG. 542.—Essential parts and electrical connections in the direct current dynamo.

Consider the conditions of the coils as viewed from one point, say N , along the lines of force in the direction N to S .

The maximum number of lines of force pass through a coil when it is crossing the line AB , and the minimum when it is crossing a line drawn from N to S ; hence, if the ring is revolving clockwise, as shown by the arrows, observe:—

1. The number of lines of force passing through the space inclosed by the coil C_1 is decreasing, and a direct (clockwise) current is induced in it.

2. The number of lines of force through the coil C_2 is increasing, and an inverse (contra-clockwise) current is induced in it; but as the coils present opposite ends when viewed from N , it is evident that the current flows in the same absolute direction in C_1 and C_2 .

3. The number of lines of force through the coil C_3 is decreasing, and a direct (clockwise) current is induced in it.

4. The number of lines of force through the coil C_4 is increasing, and an inverse current (contra-clockwise) is induced in it; but as C_3 and C_4 present opposite ends when viewed from N , the currents flow in the same absolute direction in each, but in a direction opposite to that in the coils C_1 and C_2 .

Similarly with any number of coils, the currents in all coils on one side of the line AB flow in one direction while those, in the coils on the other side of AB flow in the opposite direction.

Hence, if the ends of the wires of the coils are connected to the commutator plates, and the brushes bear upon these plates at the points *E* and *F* as shown in the figure, a direct, or continuous, current will flow from *F* to *E* through a conductor which joins the brushes.

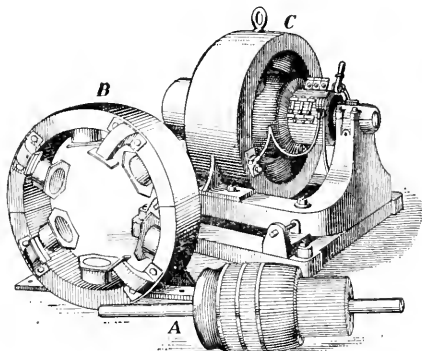

FIG. 543.—Modern direct-current dynamo. *A*, Drum armature; *B*, multipolar field; *C*, dynamo complete.

there are pairs of poles. Fig. 543 shows a modern direct-current dynamo with drum armature and multipolar field.

530. Excitation of Fields in a Dynamo. In the alternating-current dynamo the electromagnets which form the fields are sometimes excited by a small direct-current dynamo belted to the shaft of the machine (see also Fig. 539); in the direct-current dynamo the fields are magnetized by a current taken from the dynamo itself. When the *full* current generated in the armature (Fig. 544) passes through the field-magnets, which are wound with coarse wire, the dynamo is said to be *series-wound*. A dynamo of this class is used when a constant current is required, as in arc lighting. When the fields are energized by a small fraction of the current, which passes directly from brush to brush

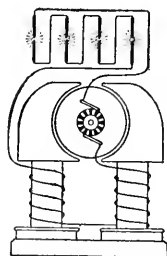

FIG. 544.—Series-wound dynamo.

through many turns of fine wire in the field coils, while the main current does work in the external circuit (Fig. 545), the dynamo is *shunt-wound*. This type is used where the output of current required is continually changing, but where the potential difference between the brushes must be kept constant, as in incandescent lighting, power distributing, etc. The regulation is accomplished by suitable resistance placed in the shunt circuit to vary the amount of the exciting current.

The regulation is more nearly automatic in the *compound-wound* dynamo. In this form the fields contain both series and shunt coils.

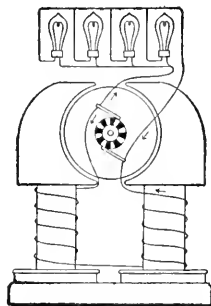

FIG. 545.—Shunt-wound dynamo.

The field-magnets, of course, lose their strength when the current ceases to flow, but the cores contain sufficient residual magnetism to cause the machine to develop sufficient current to “pick up” on the start.

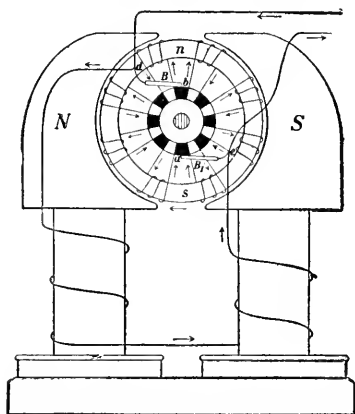

FIG. 546.—Essential parts and electrical connections in the direct-current electric motor.

531. The Electric Motor.

The purpose of the electric motor is to transform the energy of the electric current into mechanical motion. Its construction is similar to that of the dynamo. In fact, any direct-current dynamo may be used as a motor. Consider, for example, a shunt-wound

bipolar machine with Gramme-ring armature (Fig. 546) connected with an external power circuit.

The current supplied to the motor divides at d , part flows through the field-magnet coils, and part enters the armature coils by the brush B at the point b , where it divides, one portion passing through the coils on one side of the ring, and another through the coils on the other side. The currents through the armature coils re-unite at a , pass out by the brush B_1 , and are joined at e by the part of the main current which flows through the field-magnet coils.

Both the field-magnet and the armature cores are thus magnetized, and the poles are formed according to the law stated in § 501. The poles of the field-magnet are as indicated in the figure. Each half of the iron core of the armature will be an electromagnet of the horse-shoe type, having a S -pole at s and a N -pole at n . The mutual attractions and repulsions between the poles of the armature and of the field-magnet cause the armature to revolve.

532. Counter-Electromotive Force in the Motor. As the armature of the motor is revolved it will, as in the dynamo, develop an E.M.F. opposite to that of the current causing the motion. The higher the velocity of the armature, the greater is this counter-E.M.F. The electric motor is, therefore, self regulating for different loads. When the load is light, the speed becomes high and the increase in the counter-E.M.F. reduces the amount of current passing through the motor; on the other hand, when the load is heavy the velocity is decreased and the counter-E.M.F. is lessened, allowing a greater current for increased work.

When the motor starts from rest there is, at the beginning, no counter-E.M.F., and the current must be admitted to the armature coils gradually through a rheostat, (a set of resistance coils) to prevent the overheating of the wires and the burning of the insulation.

QUESTIONS AND PROBLEMS

1. Upon what is the potential difference between the brushes of a dynamo dependent ?

2. To what is the internal resistance of a dynamo due ?

3. How should a dynamo be wound to produce (1) currents of high E.M.F.; (2) a current for electroplating ?

4. A dynamo is running at constant speed ; what effect will be produced on the strength of the field-magnets by decreasing the resistance in the external circuit (*a*) when the dynamo is series-wound ; (*b*) when it is shunt-wound ?

5. What would be the effect of short-circuiting (1) a series-dynamo ; (2) a shunt-dynamo ? Explain. (A dynamo may be short-circuited by joining the brushes, or the main wires from them, by a conductor of low resistance.)

6. An alternating current dynamo has 16 poles, and its armature makes 300 revolutions per min. ; find the number of alternations per sec.

7. Why would an armature made of coils wound on a wooden core not be as effective as one with an iron core ?

8. What would be the effect upon the potential difference between the brushes of a dynamo of moving them backward and forward around the ring of commutator plates ? Explain.

9. What would be the effect upon the working of a dynamo, of connecting the commutator plates by binding a bare copper wire around them, (1) if the field-magnets are in a shunt circuit ; (2) if the field-magnet is excited by a separate dynamo ? Would a current be generated in either of these cases ? If so, where would it flow ?

533. The Transformer. If two independent coils are wound about the same iron core, as in Faraday's original experiment on induced currents (§ 517), it is obvious that an alternating current in one coil will produce an alternating current in the other if it is closed, because the core becomes magnetized in one direction, then demagnetized, and magnetized in the opposite direction at each change in the direction of the current in the primary circuit ; lines of force are thus made to pass through the secondary coil in alternate directions.

This is the principle of the transformer, a device for changing an alternating current of one electromotive force to that of another.

When the change is from low E.M.F. to high, the transformer is called a *step-up* transformer, and when from high to low, a *step-down* transformer. There are many forms of this instrument but the essential parts are all the same—two coils and a laminated soft-iron core, so placed that as many as possible of the lines of force produced by the current in one coil will pass through the space inclosed by the other.

In transformers used for commercial purposes, the coils are usually wound about a core shaped in the form of . The inner coils (Fig. 547) are the primary, and the outer the secondary. The electromotive force of the current generated in the secondary coil is to that of the primary current nearly in the ratio of the number of turns of wire in the secondary coil to the number in the primary.

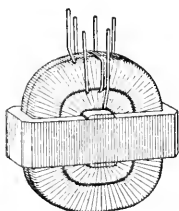

FIG. 547.—The transformer.

534. Uses of the Alternating Current. On account of the facility with which the E.M.F. of an alternating current may be changed by a transformer, alternating currents are now usually employed whenever it is found necessary or convenient to change the tension of a current. The most common illustrations are to be found in the case of the long distance transmission of electricity, where the currents generated by the dynamos are transformed into currents of very high E.M.F. to overcome the resistance of the transmission wires,* and again into currents of lower tension for use at the centres of distribution; and in the case of incandescent lighting, where it is advisable to have currents of fairly high

* There is also less waste through the heating of the conducting wire when high tension is used. If the tension is high the current is small, and the heating is proportional to the square of the current (see § 538).

tension on the street wires but, for the sake of safety and economy, currents of low E. M. F. in the lamps and house connections.

In the Hydro-electric system which supplies many centres of Ontario with electric energy, the current when first generated at Niagara Falls is at a potential of 12,000 volts. It is then transformed to 110,000 volts and transmitted over well-insulated lines. On arriving at its destination it is transformed down again for use in lighting, power and heating.

535. The Induction Coil.* In the induction coil currents of very high electromotive force are produced by the inductive action of an interrupted current. (Fig. 548.)

The essential parts of the instrument are shown in Fig. 549. It differs from an ordinary transformer mainly in having added to the primary circuit a current-breaker and a condenser.

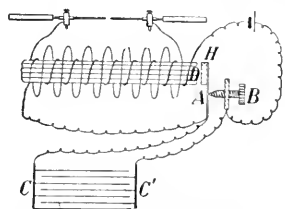

FIG. 549.—The essential parts and electrical connections in the induction coil.

The current-breaker is usually of the type illustrated in the electric bell (§ 512), but other forms are often employed. The condenser $C C'$ is made up of alternate layers of tinfoil and paraffined paper or mica, connected with the spring A and

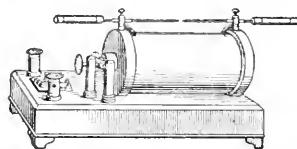

FIG. 548.—The induction coil.

to the primary circuit a current-breaker and a condenser. The primary coil consists of a few turns of stout insulated wire wound about a soft-iron core. The secondary coil, consisting of a great number of turns of very fine insulated wire, surrounds the primary coil. Its terminals are attached to binding posts placed above the coil.

* The induction coil was greatly improved by Ruhmkorff (1803-1877), a famous manufacturer of scientific apparatus in Paris, and is often called the Ruhmkorff coil.

screw *B* of the current-breaker in such a manner that one of these is joined to the even sheets of the foil, the other to the odd ones. The core is a bundle of soft-iron wires insulated from one another by shellac. Such a core can be magnetized and demagnetized more easily than one of solid iron.

533. Explanation of the Action of the Coil. When the primary circuit is completed the battery current passes through the coil and magnetizes the core. This draws in the hammer *H*, and the circuit is broken between the spring *A* and the screw *B*. The hammer then flies back, the circuit is again completed and the action is repeated. An interrupted current is thus sent through the primary coil, which induces currents of high electromotive force in the secondary.

Self-induced currents in the primary circuit interfere with the action of the coil. On completing the primary circuit, the current due to self-induction opposes the rise of the primary currents and thus diminishes the inductive effect. Similarly, the extra-current induced in the primary coil when the circuit is broken passes across the break in the form of a spark and prolongs the time of fall of the primary current, again lessening the inductive action. The condenser is introduced to prevent this latter injurious effect. When the circuit is broken the extra-current flows into the condenser and charges it, but as the two coatings are joined between *A* and *B* through the primary coil and the battery, the condenser is immediately discharged, giving rise to a current in the opposite direction which flows back through the primary coil and instantaneously demagnetizes the soft-iron core. The direct current induced in the primary coil, therefore, becomes shorter and more intense.

The potential difference between the terminals of the secondary coil can thus be made sufficiently great to cause a spark to pass between them, the length of the spark depending

on the capacity of the coil. Coils giving sparks from 18 to 24 inches are frequently manufactured.

The smaller coils are used extensively for physiological purposes and for gas engine ignition (see § 308), and the larger for exciting vacuum tubes and for wireless telegraphy (see § 575).

537. Telephone. The telephone, as invented by Alexander Graham Bell, employs the principle of induced currents for reproducing sound waves.

The transmitter and receiver first used were alike. Each consisted of an iron diaphragm *C*, supported in front of one end of a permanent bar-magnet *A*, about which was wound a coil of fine insulated wire *B*, as shown in Fig. 550.

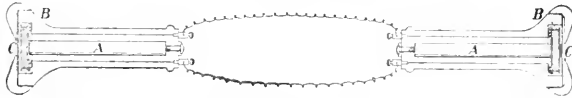

FIG. 550.—The essential parts and electrical connections in the original Bell telephone.

The terminals of the transmitter and receiver coils are connected by the line wires. The sound waves falling upon the diaphragm of the transmitter cause it to vibrate, and these vibrations produce fluctuations in the number of lines of force passing through the coil, which cause induced currents to surge to and fro in the circuit. The currents alternately strengthen and weaken the magnet of the receiver and thus set up vibrations in the diaphragm similar to those in the diaphragm of the transmitter.

The Bell receiver is very sensitive and is still used on all telephone systems, but a magnet of the horse-shoe type is now usually employed instead of the bar-magnet used in the original form. The transmitter was not found satisfactory, especially on long distance lines, and has been replaced by one of the microphone type (Fig. 551).

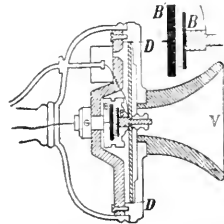

FIG. 551.—The microphone transmitter used in the Bell system.

At the back of the mouthpiece is a metallic diaphragm D , B is a carbon button attached to the diaphragm, and B' another carbon button attached to the frame of the instrument, opposite to B . The space between the carbon buttons is loosely packed with coarse granulated carbon. (See upper small figure.)

The connections of the instruments in the complete circuit are shown in Fig. 552. The transmitter acts on the principle

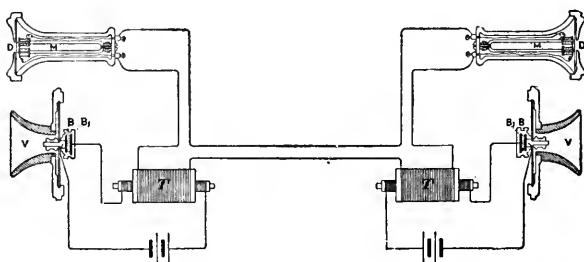

FIG. 552.—Electrical connections in telephone circuit. V , mouthpiece of transmitter; B , B_1 , carbon buttons; D , diaphragm of receiver, and M its permanent bar-magnet. T is a transformer.

that the conductivity of the granular carbon varies with the varying pressure exerted upon it by the button B , as the diaphragm vibrates under the action of the sound waves. The current passing from the battery through the primary coil of a transformer T will, therefore, be fluctuating in character and will induce a current of varying strength and varying direction, but of higher electromotive force, in the secondary coil which is connected in the main line with the receiver. This current will cause corresponding variations in the magnetic state of the electromagnet of the receiver and thus set up vibrations in its diaphragm, which will reproduce the sound waves that caused the diaphragm of the transmitter to vibrate.

CHAPTER XLVIII

HEATING AND LIGHTING EFFECTS OF THE ELECTRIC CURRENT

538. Heat Developed by an Electric Current. In discussing the sources of heat (§§ 242-245) we referred to the fact that whenever an electric current meets with resistance in a conductor heat results. Now, as no body is a perfect conductor of electricity, a certain amount of the energy of the electric current is always transformed into the energy of molecular motion. Joule, who investigated this subject, found by comparing the results of numerous experiments that in a given time *the number of heat units developed in a conductor varies as its resistance and as the square of the strength of the current.*

539. Practical Applications. Resistance wires heated by an electric current are used for various purposes, such as performing surgical operations, igniting fuses, cooking, heating electric cars, etc. In electric toasters and flat-irons the resistance wire is an alloy of nickel and chromium. This can be kept at a red heat for weeks without injury, whereas an iron wire would soon deteriorate.

540. Electric Furnace. In Fig. 553 is shown one kind of electric furnace. Carbon rods *C, C* pass through the asbestos walls of a chamber about 4 in. long, $2\frac{1}{2}$ in. wide and $1\frac{1}{2}$ in. high. Between them is a small crucible, and the space about is packed with granular carbon (arc lamp carbon rods broken into pieces about as large as coarse granulated sugar). The

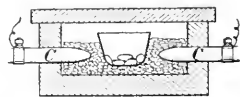

FIG. 553.—Electric resistance furnace.

furnace is joined to an electric-lighting circuit through a rheostat. The resistance of the granulated carbon is considerable, and sufficient heat can be generated to melt pieces of copper in the crucible. This is a *resistance* furnace. Carborundum is produced from coke sand, salt and sawdust in a furnace of this type.

In the *arc* furnace the heat is produced at a break in the circuit, as illustrated in the arc lamp (§ 544).

541. Electric Welding. Rods of metal are welded by pressing them together with sufficient force while a strong current of electricity is passed through them. Heat is developed at the point of junction, at which place the resistance is greatest, and the metals are softened and become welded together. But the most important application of the heating effects of the electric current is to be found in electric lighting.

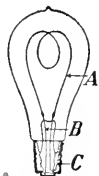

Fig. 554.—The incandescent lamp. *A*, carbon filament; *B*, conducting wires fused in glass; *C*, brass base to which one wire is soldered.

542. Incandescent Lamp. The construction of the incandescent lamp in common use is shown in Fig. 554. A carbon filament made by carbonizing a thread of bamboo or cotton fibre at a very high temperature, is attached to conducting wires and inclosed in a pear-shaped globe, from which the air is then exhausted. The conducting wires where they are fused into the glass are of platinum. When a sufficiently strong current is passed through the carbon filament, which has a high resistance, it is heated to incandescence and yields a bright steady light. The carbon is infusible, and does not burn for lack of oxygen to unite with it.

Lamps are now also being used in which the filament is fine wire of the metal tungsten.

The Nernst lamp differs from the ordinary incandescent lamp in that the substance made incandescent consists of a small rod known as a *glower*, composed of oxides of the rare earths. Since these oxides are incombustible the glower is not inclosed in an exhausted globe. Its chief drawback is that the glower is a non-conductor when cold, and must be heated before the current will pass through it. Both the tungsten and Nernst lamps give much more light than the ordinary carbon filament lamp for the same current.

543. Grouping of Lamps. All the incandescent lamps to be used in the same circuit are so constructed as to give their proper candle power when the same potential-difference is maintained between their terminals. This is generally from 100 to 110 volts. The lamps are connected *in multiple*, or *parallel*, that is, the current from the leading wires divides, and a part flows through each lamp, as shown in Fig. 545. The dynamo is regulated to maintain a constant potential difference between the leading wires.

544. The Arc Light. If two carbon rods, connected by conductors to the poles of a sufficiently powerful battery or dynamo, are touched together and then separated a short distance the current continues to flow across the gap, developing intense heat and raising the terminals to incandescence, thus producing a powerful light, generally known as the *arc light*.

When the carbon points are separated by air only, the potential difference between them, when connected with the poles of an ordinary arc-light dynamo, is not sufficient to cause a spark to pass, even when they are very close together: but if they are in contact and then separated while the current is

passing through them, the "extra-current" spark produced on separation (§ 523) volatilizes a small quantity of the carbon between the points, and a conducting medium, consisting of carbon vapour and heated air, is thus produced, through which the current continues to flow.



FIG. 555.—The arc light.

Since this medium has a high resistance, intense heat is developed and the carbon points become vividly incandescent and burn away slowly in the air. When a direct current is used, the point of the positive carbon becomes hollowed out in the form of a crater, and the negative one becomes pointed, as shown in Fig. 555. The greater part of the light is radiated from the carbon points, the positive one being the brighter.

545. The Inclosed Arc—The Arc-light Automatic Feed.

The open arc is now being largely superseded by the "inclosed arc," a form in which the carbon points are inclosed in a glass or porcelain globe with an air-tight joint at the bottom (Fig. 556), and with but sufficient opening at the top to give the upper carbon freedom. Since the oxygen in the globe soon becomes exhausted, and the absence of draft prevents its renewal, the carbons of the inclosed arc burn away very slowly. Ordinarily they last about ten times as long as when burning in the open air.

In Figs. 556, 557, *A* and *B* are the terminals by which the current enters and leaves the lamp. Let it enter at *A*, and suppose the switch to be open so that it cannot pass along *x* directly to *B*. The current goes to *B* by two paths. In the

first, it passes through the magnet *m*, down through the carbons *u* and *l*, and then to *B* by way of *g*. In the second, it traverses the magnet *n* and then goes on to *B*. The strength of current in each case will depend on the resistance of the path.

When *m* is magnetized the plunger *c* is drawn up, and this raises *d* which is attached to one end of the rocking-arm *r*.

FIG. 556.—Showing the mechanism of the inclosed arc lamp. The automatic feed is much the same in all arc lamps.

This again lifts the clutch *e* which raises the upper carbon *u*. If the carbons get too far apart the resistance increases and more current passes through *n*, which draws up its plunger *f*. This raises the other end of *r*, sets free the clutch, and the carbon drops. In this way the carbons are kept at the proper distance apart.

The resistance *s* carries some of the current on starting; when *d* rises it is cut out. An almost air-tight plunger in *h* prevents too abrupt motions of *c*.

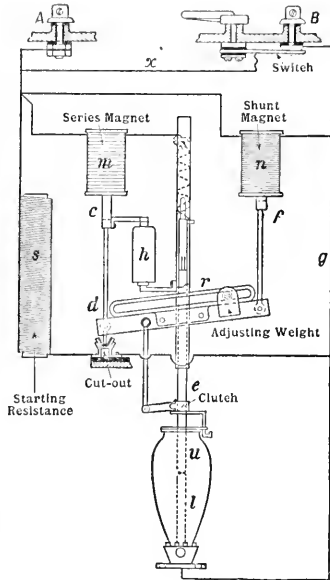

FIG. 557.—Diagram showing the connections in the inclosed arc lamp. The lamp illustrated in this and the last figure is intended to be joined in series with others on an alternating current circuit, but they are all similar in principle.

CHAPTER XLIX

ELECTRICAL MEASUREMENTS

546. Ohm's Law. We have learned that the strength of a current, or the quantity of electricity which flows past a point in a circuit in one second, depends on the E.M.F. of the current and the resistance of the circuit. The exact relation which exists between these quantities was first enunciated by G. S. Ohm in 1826. It may be thus stated:—



GEORG SIMON OHM (1789-1854). Born at Erlangen; died at Munich. Discoverer of Ohm's Law.

The current varies directly as the electromotive force and inversely as the resistance of the circuit. From a practical point of view this is one of the most important generalizations in electrical science. It is known as OHM'S LAW.

547. Practical Electrical Units. It is evident that if units of any two of the three quantities involved in the relation stated in Ohm's Law are adopted and defined, the unit of the third quantity is also determined. This was the procedure followed at the International Congress on Electrical Units which met in London in 1908.

The following definitions of units were adopted:—

THE UNIT OF RESISTANCE. *The International Ohm is the resistance offered to an unvarying current by a column of mercury at the temperature of melting ice, 14.4521 grams in mass, of a constant cross-sectional area, and of a length of 106.300 cm.*

UNIT OF CURRENT STRENGTH. *The International Ampere is the unvarying electric current, which when passed through a solution of silver nitrate under certain stated conditions, deposits silver at the rate of 0.00111800 grams per second.*

UNIT OF ELECTROMOTIVE FORCE. *The International Volt is the electrical pressure which when steadily applied to a conductor, whose resistance is one International Ohm, will produce a current of one International Ampere.*

Then, if C is the measure of a current in amperes; R , the resistance of the circuit in ohms; and E , the electromotive force in volts, Ohm's Law may be expressed as follows:—

$$C = \frac{E}{R}.$$

PROBLEMS

1. The electromotive force of a battery is 10 volts, the resistance of the cells 10 ohms, and the resistance of the external circuit 20 ohms. What is the current?

2. The difference in potential between a trolley wire and the rail is 500 volts. What current will flow through a conductor which joins them if the total resistance is 1000 ohms?

3. The potential difference between the terminals of an incandescent lamp is 104 volts when one-half an ampere of current is passing through the filament. What is the resistance?

4. A dynamo, the E.M.F. of which is 4 volts, is used for the purpose of copper-plating. If the resistance of the dynamo is $\frac{1}{100}$ of an ohm, what is the resistance of the bath and its connections when a current of 20 amperes is passing through it?

5. What must be the E.M.F. of a battery in order to ring an electric bell which requires a current of $\frac{1}{10}$ ampere, if the resistance of the bell and connection is 200 ohms, and the resistance of the battery 20 ohms?

6. What must be the E.M.F. of a battery required to send a current of $\frac{1}{100}$ of an ampere through a telegraph line 100 miles long if the resistance of the wires is 10 ohms to the mile, the resistance of the instruments being 300 ohms, and of the battery 50 ohms, if the return current through the earth meets with no appreciable resistance?

7. The potential difference between the carbons of an arc lamp is 50 volts and the resistance of the arc 2 ohms. If the arc exerts an opposing E.M.F. of its own of 30 volts, what is the current passing through the carbons?

8. A dynamo, of which the E.M.F. is 3 volts, is used to decompose water. What is the total resistance in the circuit when a current of one-half an ampere passes through it, if the counter electromotive force of polarization of the electrodes is 1.5 volts?

548. Fall of Potential in a Circuit. If a battery or dynamo is generating a current in a circuit, it is evident that the E.M.F. required to maintain this current in the whole circuit is greater than that required to overcome the resistance of only a part of the circuit. For example, if the total resistance is 100 ohms, and the E.M.F. is 1000 volts, the current in the circuit is 10 amperes. Here an E.M.F. of 1000 volts is required to maintain a current of 10 amperes against a total resistance of 100 ohms; manifestly to maintain this current in the part of the circuit of which the resistance is, say 50 ohms, an E.M.F. of but 500 volts will be required. This is usually expressed by saying that there is a fall in potential of 500 volts in the part of the circuit whose resistance is 50 ohms.

In general, if there is a closed circuit through which a current is flowing, the fall in potential in any portion of the circuit is proportional to the resistance of that portion of the circuit.

PROBLEMS

1. The end A of the wire ABC is connected with the earth, and the difference in potential between the other end C and the earth is 100 volts. If the resistance of the portion AB is 9.6 ohms and that of BC 2.4, what current will flow along the wire, and what will be the potential difference between the point B and the earth?

2. The poles of a battery are connected by a wire 8 metres long, having a resistance of one-half ohm per metre. If the E.M.F. of the battery is 7 volts and the internal resistance 10 ohms, find the distance between two points on the wire such that the potential difference between them is 1 volt. What is the current in the wire?

3. The potential difference between the brushes of a dynamo supplying current to an incandescent lamp is 104 volts. If the resistance in the

wires on the street leading from the dynamo to the house is 2 ohms, that of the wires in the house 2 ohms, and that of the lamp 204 ohms, what is the fall in potential in (1) the wires on the street, (2) the wires in the house, and what is the potential difference between the terminals of the lamp?

4. A dynamo is used to light an incandescent lamp which requires a current of 0.6 ampere and a potential difference between its terminals of 110 volts. If the wires connecting the dynamo with the lamp have a resistance of 5 ohms, find the potential differences which must be maintained between the terminals of the dynamo to light the lamp properly?

5. A cell has an internal resistance of 0.3 ohm, and its E.M.F. on open circuit is 1.8 volts. If the poles are connected by a conductor whose resistance is 1.2 ohms, what is the current produced, and what is the potential difference between the poles of the cell?

6. If the E.M.F. of a cell is 1.75 volts, and its resistance 3 ohms, find the internal drop in potential when the circuit is closed by a wire whose resistance is (a) 4 ohms, (b) 32 ohms.

549. Quantity of Electricity. Let us refer again to the flow of water through a pipe (§ 453). The *current strength* is the *rate of flow*. It depends upon the difference of pressure at the ends of the pipe, and the resistance of the pipe. But we often wish to know the *quantity* of water passing in a given time. Obviously we have the relation,

$$\text{Quantity} = \text{rate of flow} \times \text{time of flow.}$$

We might measure rate of flow in gallons-per-second, and quantity in gallons.

In electrical measurements there is something similar. We may think of the quantity of electricity passing a cross-section of a circuit in a given time, and as before we have the relation,

$$\text{Quantity of electricity} = \text{current strength} \times \text{the time.}$$

If we measure current strength in amperes, and time in seconds, the quantity will be given in *coulombs*; and we have the definition:—A COULOMB is the amount of electricity which passes a point in a circuit in one second when the strength of the current is one ampere.

The ampere corresponds to gallons-per-second, the coulomb to gallons.

If the strength of a current is C amperes and the quantity flowing past a point in the circuit in t seconds is Q coulombs, then $Q = Ct$.

Practical electricians frequently employ the *ampere-hour* as the unit quantity, as for example, in estimating the capacity of a storage cell. A battery contains 100 ampere-hours, when it will furnish a current of one ampere for 100 hours, or 2 amperes for 50 hours, etc.

550. Work Done in an Electric Circuit. The water analogy will assist us again in getting a clearer grasp of the principle by which the energy expended in an electric circuit may be expressed.

Just as the work done by a stream depends on the quantity of water and the distance through which it falls, so the work done in any portion of an electric circuit depends on the quantity of electricity which passes through it and the difference in potential between its terminals. One *joule*, or 10^7 ergs, of work is done, when one coulomb of electricity falls through one volt.

Hence, if Q is the quantity of electricity passing through a wire



FIG. 558.—Portion of an electric circuit.

AB (Fig. 558) and V denotes the fall in potential from A to B , the work done by the current = $QV = CVt$.

551. Rate at Which Work is Done in an Electric Circuit. The power or rate at which work is done in an electric circuit is estimated in *joules per sec.*, that is, in *watts* (§ 71).

Thus if a current of C amperes flows through a circuit in which there is a drop of potential of V volts, energy is being delivered at the rate of VC watts.

Hence W (power in watts) = fall in potential (in volts) \times current (in amperes).

Since one horse-power = 746 watts (§ 71).

Power (in horse-power) = $\frac{\text{Potential diff. (in volts)} \times \text{current (in amperes)}}{746}$

552. Relation Between Heat Energy and the Energy of the Electric Current. The mechanical equivalent of heat is 4.2 joules per calorie, that is one calorie = 0.24 joules. Hence if an electric current of C amperes is flowing in a circuit in which there is a fall in potential of V volts, and all the energy of the current is

transformed into heat, $I \times C \times 0.24$ calories will be developed every second.

More frequently, however, the *quantity* of heat produced by a current is expressed in terms of the current and the resistance. By Ohm's Law, $I = C \times R$; therefore the heat developed in a circuit, whose resistance is R Ohms by a current of C amperes is $C^2R \times 0.24$ calories per second, or in t seconds the heat produced = $C^2Rt \times 0.24$ calories. This accords with results determined experimentally by Joule (§ 538).

553. Work Done in an Electric Lamp. The efficiency of an electric lamp is usually determined in watts per candle power.

Thus if a 16-candle power incandescent lamp requires a current of $\frac{1}{2}$ ampere in a 110 volt circuit, its efficiency is $\frac{110 \times \frac{1}{2}}{16}$ or 3.4 watts per candle power.

For commercial purposes, the energy consumed by a lamp in a given time is usually measured in *watt-hours*. For example, if a customer has a lamp of the above description burning for 100 hours per month, he pays monthly for 55×100 , or 5500 watt-hours of energy.

PROBLEMS

1. A current of 10 amperes flows through an arc light circuit. What quantity of electricity will pass across the arc of one of the lamps in a night of 10 hours?

2. The difference in potential between a trolley wire and the rail which carries the return circuit is 500 volts, and the motor of a car takes an average current of 25 amperes. How much work is done each hour in the circuit joining the trolley wire and the rail?

3. Find the horse power necessary to run an electric light installation taking 125 amperes at 110 volts.

4. The resistance of the filament of an incandescent lamp is 200 ohms and it carries a current of 6 amperes. Find the amount of heat (in calories) developed in this filament per minute.

5. A 25-candle power tungsten lamp, when used in a 25-volt circuit takes one ampere of current. Find its efficiency.

6. The potential difference between the wires entering a house is 104 volts, and an average current of 8 amperes flows through them for 4 hours per day. How many watt-hours of energy must the householder pay for in a month of 30 days? Find the cost at 8 cents per kilowatt-hour. (1 kilowatt = 1000 watts.)

554. Resistance Boxes. The standard resistance was defined in § 547. It is obvious that for the purpose of comparing resistances it would be inconvenient to use mercury columns in ordinary experiments. In practical work resistance coils are used for this purpose. Lengths of wire of known resistance are wound on bobbins and connected in sets in *resistance boxes*. Fig. 559 shows the common method of joining the

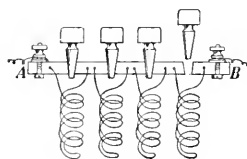

FIG. 559.—Connections in a resistance box.

coils. A current in passing from *A* to *B* meets with practically no resistance from the heavy metallic bar when all the plugs are inserted. To introduce a given resistance, the plug short-circuiting the proper coil is removed and the current is made to traverse the resistance wire.

For convenience in calculation the coils are usually grouped very much as weights are arranged in boxes. For example, a set of coils of 1, 2, 2, 5, 10, 10, 20, 50, 100, 100, 200, 500 ohms may be combined to give any resistance from 1 to 1000 ohms.

555. Determination of Resistance ; Method of Substitution.

If the current strength and electromotive force of a current are known or can be determined with an ammeter and a voltmeter, the resistance in the circuit can be calculated from Ohm's Law $R = E/C$.

To determine an unknown resistance, when these factors are not known, the conductor is placed in a circuit with a cell of constant E.M.F. and a sensitive galvanometer. The deflection of the needle of the galvanometer is noted, and the unknown resistance then replaced by a resistance box. The coils are adjusted so as to bring the needle to its former position. The resistance thus placed in the circuit is evidently the resistance of the conductor.

This method, which is usually known as the *method of substitution*, was employed by Ohm in his first experiments.

Obviously variations in the E.M.F. of the cell used will introduce errors in the determination.

556. The Wheatstone Bridge. Wheatstone, who was a contemporary of Ohm and had followed his experiments, invented what is known as the "Wheatstone Bridge," an arrangement of coils which makes the determination independent of changes in the E. M. F. of the cell. The coils are arranged in three sets *A*, *B*, and *C*, with connections for a battery, a galvanometer and the resistance to be measured, as shown in Fig. 560.

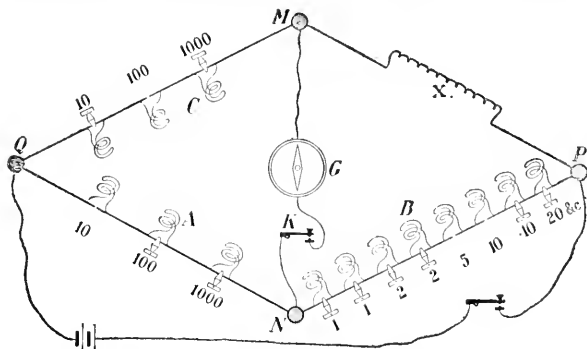

Fig. 560.—Electrical connections in the Wheatstone Bridge.

They are mounted in a box and the changes in the resistance are made in the usual way, by inserting or withdrawing conducting plugs, as shown in Fig. 559.

The branches *A* and *C* usually have three coils each, the resistances of which are respectively 10, 100 and 1000 ohms, and the branch *B* has a combination of coils, which will give any number of units of resistance from 1 to 11,110 ohms. The conductor, whose resistance *X* is to be measured is inserted in the fourth branch of the bridge (Fig. 560), and the resistances *A*, *B* and *C* adjusted until the galvanometer connecting *M* and *X* stands at zero when the keys are closed.

Then the current from the battery is flowing from *P*, partly through *X* and *C*, and partly through *B* and *A* to *Q*, and since

no current flows from M to N , the potential of M must be the same as that of N ; therefore the fall in potential from P to N in the circuit PNQ is the same as the fall from P to M in the circuit PMQ ; but the fall in potential in a part of a circuit is proportional to the resistance of that portion of the circuit.

$$\text{Hence, } \frac{X}{C} = \frac{B}{A} \text{ or } X = \frac{B \times C}{A}.$$

The resistances A , B and C are read from the instrument, and the value of X is calculated from the formula.

557. Laws of Resistance. The resistances of conductors under varying conditions have been determined by various investigators with great care. The general results are given in the following laws:—

1. *The resistance of a conductor varies directly as its length.*
2. *The resistance of a conductor varies inversely as the area of its cross-section. In a round conductor, therefore, the resistance varies inversely as the square of the diameter.*
3. *The resistance of a conductor of given length and cross-section depends upon the material of which it is made.*

Hence, if l denotes the length of a conductor, A the area of its cross-section and R its resistance,

$$R = \rho \frac{l}{A},$$

where ρ is a constant depending on the material of the conductor and the units of measurement used. The constant ρ is known as the *Specific Resistance* of the material. For scientific purposes the specific resistance is usually expressed as the resistance in microhms or millionths of an ohm, of a cube of this material, whose edge is one centimetre in length, when a current is made to flow parallel to one of its edges.

The following table gives the specific resistances in microhms of some well-known substances at 0°C.

TABLE OF RESISTANCES AT 0°C.

Aluminium wire.....	2.91	Platinum wire (annealed).	9.04
Copper wire (annealed)...	1.58	German Silver wire.....	20.89
Carbon (lamp filament) ..	4000	Iron (telegraph wire).....	9.70
Mercury	94.07	Silver wire (annealed)....	1.46
Nickel wire (annealed)...	12.43	Steel (rails)	12.00

558. Resistance and Temperature. If we connect a piece of fine iron or platinum wire in a circuit with a voltaic cell and a galvanometer and note the deflection of the needle, we shall find on heating the wire with a lamp that the galvanometer indicates a weakening in the current. The rise in the temperature of this wire must, therefore, have been accompanied by an increase in its resistance. This action is typical of metals in general.

The resistance of nearly all pure metals increases about 0.4 per cent. for each rise in temperature of 1° C. The resistance of carbon on the other hand diminishes on heating. The filament of an incandescent lamp, for instance, has when hot only about one-half the resistance which it has when cold. The resistance of an electrolyte also decreases with a rise in temperature.

QUESTIONS AND PROBLEMS

1. What is the resistance of a column of mercury 2 metres long and 0.6 of a square millimetre in cross-section at 0° C ?
2. The resistance at 0° of a column of mercury 1 metre in length and 1 sq. mm. in cross-section is called a "Siemens' Unit." Find the value of this unit in terms of the ohm.
3. Copper wire $\frac{1}{2}$ inch in diameter has a resistance of 8 ohms per mile. What is the resistance of a mile of copper wire the diameter of which is $\frac{1}{36}$ inch ?
4. A mile of telegraph wire 2 mm. in diameter offers a resistance of 13 ohms. What is the resistance of 440 yards of wire 0.8 mm. in diameter made of the same material ?
5. What length of copper wire, having a diameter of 3 mm., has the same resistance as 10 metres of copper wire having a diameter of 2 mm.?

6. On measuring the resistance of a piece of No. 30 B.W.G. (covered) copper wire 18.12 yards long I found it to have a resistance of 3.02 ohms. Another coil of the same wire had a resistance of 22.65 ohms. What length of wire was there in the coil?

7. Two wires of the same length and material are found to have resistances of 4 and 9 ohms respectively. If the diameter of the first is 1 mm., what is the diameter of the second?

8. What must be the thickness of copper wire, which, taking equal lengths, gives the same resistance as iron wire 6.5 mm. in diameter, the specific resistance of iron being six times that of copper?

9. Find the length of an iron wire $\frac{1}{80}$ inch in diameter which will have the same resistance as a copper wire $\frac{1}{60}$ inch in diameter and 720 yards long, the conducting power of copper being six times that of iron.

10. A wire made of platinoid is found to have a resistance of 0.203 ohm per metre. The cross-section of the wire is 0.016 sq. cm. Express the specific resistance of platinoid in microhms.

11. Taking the specific resistance of copper as 1.58, calculate (1) the resistance of a kilometre of copper wire whose diameter is 1 mm., (2) the resistance of a copper conductor 1 sq. cm. in area of cross-section, and long enough to reach from Niagara to New York, reckoning this distance as 480 kilometres.

12. A current flows through a copper wire, which is thicker at one end than the other. If there is any difference either (1) in the strength of the current at, or (2) in the temperature of, the two ends of the wire, state how they differ from each other, and why.

559. Resistance in a Divided Circuit. When a current is divided and made to flow from a conductor *A* to another *B* through two parallel circuits (Fig. 561),

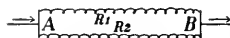

FIG. 561.—Divided circuit.

it is often necessary to determine the resistance of a single wire, which will be equivalent to the two in parallel, and to find the fraction of the total current which flows through each wire.

Let *E* denote the difference in potential between *A* and *B* and *R*₁ and *R*₂ the resistances of the wires.

Then the current through the first wire = $\frac{E}{R_1}$ (Ohm's Law),

and " " " " second " = $\frac{E}{R_2}$.

Total current through the two wires = $\frac{E}{R_1} + \frac{E}{R_2}$.

But the total current = $\frac{E}{R}$, where R is the resistance of a single wire equivalent to the two.

$$\text{Therefore } \frac{E}{R} = \frac{E}{R_1} + \frac{E}{R_2}$$

$$\text{that is } \frac{1}{R} = \frac{1}{R_1} + \frac{1}{R_2}$$

Again, the fraction of the total current in the first wire

$$= \frac{\frac{E}{R_1}}{\frac{E}{R_1} + \frac{E}{R_2}} = \frac{R_2}{R_1 + R_2}$$

Similarly, the fraction of the total current in the second wire

$$= \frac{R_1}{R_1 + R_2}$$

560. Shunts. When it is undesirable to send the whole current to be measured through a galvanometer or other current-measuring instrument, a definite fractional part of the current is diverted by making the instrument one of two parallel conductors in the circuit, as shown in Fig. 562.

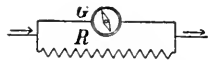

FIG. 562.—Galvanometer and shunt.

The conductor R "in parallel" with the galvanometer G is called a *shunt*.

If G is the resistance of the galvanometer, R the resistance of the shunt, and C the total current, the amount of current through the galvanometer = $\frac{R}{G + R} \times C$ (§ 559).

For the sake of facility in calculation, it is usual to make R $\frac{1}{9}$, $\frac{1}{99}$, or $\frac{1}{999}$ of G , when, by the above formula, the current through the galvanometer will be $\frac{1}{10}$, $\frac{1}{100}$, or $\frac{1}{1000}$, respectively, of the total current to be measured.

PROBLEMS

1. The poles of a voltaic battery are connected by two wires in parallel. If the resistance of one is 10 ohms and that of the other 20 ohms, find (1) the resistance of a single wire equivalent to the two in parallel; (2) the proportion of the total current passing through each wire.

2. Find the total resistance when the following resistances are joined in series:— $3\frac{1}{2}$ ohms, $2\frac{1}{3}$ ohms, $2\frac{1}{4}$ ohms. What would be the joint resistance if the resistances were joined in parallel?

3. What must be the resistance of a wire joined in parallel with a wire whose resistance is 12 ohms, if their joint resistance is 3 ohms?

4. The joint resistance of ten similar incandescent lamps connected in multiple is 10 ohms. What is the resistance of a single lamp?

5. Four incandescent lamps are joined in parallel on a 100-volt circuit. If the resistances of the lamps are respectively 100 ohms, 200 ohms, 300 ohms and 400 ohms, find (1) the total current passing through the group of lamps; (2) the proportion of the total current passing through the first lamp; (3) the resistance of a single lamp which would take the same current as the group.

6. A galvanometer whose resistance is 1000 ohms is used with a shunt. If $\frac{1}{11}$ of the total current passes through the galvanometer, what is the resistance of the shunt?

7. If the shunt of a galvanometer has a resistance of $\frac{1}{n}$ of the galvanometer, what fraction of the total current passes through the galvanometer?

8. The internal resistance of a Daniell's cell is 1 ohm; its terminals are connected (a) by a wire whose resistance is 4 ohms, (b) by two wires in parallel, one of the wires having a resistance of 4 ohms, the resistance of the other wire being 1 ohm. Compare the currents through the cell in the two cases.

561. Grouping of Cells or Dynamos. Electrical generators may be connected in various ways to give a current in the same circuit.

They are connected *in series* or *tandem* when the negative terminal of one is connected with the positive terminal of the next (Fig. 563), and



FIG. 563.—Cells connected in series.

in multiple, or *parallel*, when all the positive terminals are connected to one conductor and all the negatives to another (Fig. 564). Sometimes combinations of these

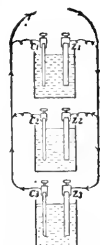

FIG. 564.—Cells connected in multiple.

methods of arrangement are employed as shown in Figs. 565, 566.

562. Current Given by Series Arrangement. If n

cells are arranged in series, and r is the internal resistance of each cell, it is evident that the resistance of the group = nr , because the current has to pass through a liquid conductor n times as long as that between the plates of a single cell.

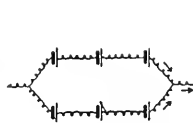

FIG. 565.

Cells connected in multiple-series.

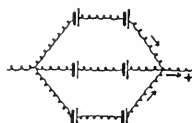

FIG. 566.

Cells connected in multiple-series.

If the potential-difference between the plates of a single cell (Fig. 563) is e , the potential-difference between Z_1 and C_1 is e ; but when C_1 and Z_2 are connected by a short thick conductor there is practically no fall in potential between them, therefore the potential-difference between Z_1 and Z_2 is e . Again, the potential-difference between Z_2 and C_2 is e , therefore the potential-difference between Z_1 and C_2 is $2e$. Similarly, for 3, 4, etc., cells the potential-differences are respectively $3e$, $4e$, etc. Hence, the E. M. F. of n cells in series is ne .

Let E denote the E. M. F. and R the resistance of this group, and let R_1 denote the external resistance in this circuit.

By Ohm's Law,
$$C = \frac{E}{R},$$

but $E = ne$, and $R = nr + R_1$;

Hence
$$C = \frac{ne}{nr + R_1}.$$

563. Current Given by Multiple Arrangement. If n cells are arranged in multiple, and r is the internal resistance of a single cell, the internal resistance of the group = $\frac{r}{n}$, because the current in passing through the liquid from one set of plates to the other has n paths opened up to it, and therefore the sectional area of the column of liquid traversed is n times that of one cell, hence the resistance is only $\frac{1}{n}$ of that of one cell (§ 557). When all the positive plates are connected they are at the same potential; for a similar reason all the negative plates are at the same potential, hence the E.M.F. of n cells in multiple is the same as that of one cell.

This method of grouping is equivalent to transforming a number of single cells into one large cell, the Z plates being united to form one large Z plate, and the C plates to form one large C plate. It must be remembered that the potential-difference between the plates of a cell is independent of the size of the plates. (§ 473.)

If E is the E.M.F., R the resistance of the group, and R_1 the external resistance,

$$C = \frac{E}{R + R_1} = \frac{e}{\frac{r}{n} + R_1}.$$

564. Current Given by Multiple-Series Arrangement. Finally let us consider an arrangement of the cells, partly in series and partly in parallel. Suppose them to be divided equally into sets, and let the cells in a set be joined in series while the sets themselves are arranged in parallel (see Figs. 565, 566).

Let each set contain n cells, and let there be m sets. There are mn cells in all.

Let e volts be the E.M.F. of each cell, r ohms its internal resistance, and R_1 ohms the external resistance of the circuit.

Then since n cells are joined in series, the E.M.F. of each set is ne volts. The internal resistance of each set is nr ohms, but as there are m sets arranged in parallel, the total resistance of the battery is $\frac{1}{m}$ of this, that is, $\frac{nr}{m}$ ohms.

Hence the resistance of the entire circuit is $\frac{nr}{m} + R_1$ ohms, and the

$$\text{Current } C = \frac{ne}{\frac{nr}{m} + R_1} \text{ amperes.}$$

565. Best Arrangement of Cells. It is manifest that when the external resistance is very great as compared with the internal resistance, in order to overcome the resistance the electromotive force must be increased, even at the expense of increasing the internal resistance, and the series arrangement of cells is the best. When the external resistance is very low as compared with the internal resistance, the object of the grouping is to lower as far as possible the internal resistance, and the multiple arrangement is the best. Between these extremes of high and low external resistance some form of multiple-series grouping gives the strongest current.

It can be shown that for a given external resistance the maximum current from a given number of cells is obtained when the cells are so connected that the internal resistance of the battery is as nearly as possible equal to the external resistance.

PROBLEMS

1. If the E.M.F. of a Grove cell is 1.8 volts and its internal resistance is 0.3 ohm, calculate the strength of current when 50 Grove cells are united in series and the circuit is completed by a wire whose resistance is 15 ohms.

2. If 6 cells, each with $\frac{1}{2}$ ohm internal resistance, and 1.1 volts E.M.F., are connected (a) all in series, (b) all in parallel, (c) in two parallel sets of three cells each (Fig. 565); calculate the current sent in each case through a wire of resistance 0.8 ohm.

3. Ten voltaic cells, each of internal resistance 2 ohms and E.M.F. 1.5 volts, are connected (a) in a single series, (b) in two series of five each, the like ends of the two series being joined together. If the terminals are in each case connected by a wire whose resistance is 10 ohms, find the strength of the current in the wire in each case.

4. The current from a battery of 4 similar cells is sent through a tangent galvanometer, the resistance of which, together with the attached wires, is exactly equal to that of a single cell. Show that the galvanometer deflection will be the same whether the cells are arranged all in multiple or all in series.

5. Calculate the number of cells required to produce a current of 50 milli-amperes (1 milli-ampere = $\frac{1}{1000}$ ampere), through a line 114 miles long, whose resistance is $12\frac{1}{2}$ ohms per mile, the available cells of the battery having each an internal resistance of 1.5 ohms, and an E.M.F. of 1.5 volts.

6. You have a battery of 48 Daniell cells, each of 6 ohms internal resistance, and wish to send the strongest possible current through an external resistance of 15 ohms. By means of diagrams show various ways of arranging the cells and calculate the strength of current in each case. Find also in each case the difference of potential between the poles of the battery, assuming that the E.M.F. of a Daniell cell is 1.07 volts.

7. A circuit is formed of 6 similar cells in series and a wire of 10 ohms resistance. The E.M.F. of each cell is 1 volt and its resistance 5 ohms. Determine the difference of potential between the positive and the negative pole of any one of the cells.

CHAPTER L

OTHER FORMS OF RADIANT ENERGY

566. Beyond the Visible Spectrum. As has been pointed out (Chap. XXXIX), when white light is passed through a prism it is thereby separated into its constituent parts, and on a screen placed in its path (see Fig. 402), we observe a *spectrum*, with its colours ranging from violet at one end to red at the other. The wave-length of the extreme red is 0.000,8 mm. or about $\frac{1}{300000}$ inch; that of the extreme violet is 0.000,4 mm. or about $\frac{1}{600000}$ inch. If we considered these waves as we do sound waves we would say that the visible radiation corresponds to *one octave*.

The question arises, are there radiations beyond those which give rise to the red and the violet sensations?

567. Waves beyond the Violet. In order to investigate this question let us receive the spectrum upon a photographic plate. Upon developing it we find that while it has been scarcely affected by the red and the yellow light, the blue and the violet have produced strong action, and further, that decided action has been produced *beyond the violet*. By suitable means photographic action has been traced to wave-lengths not greater than 0.000,1 mm., that is, to about two 'octaves' above the violet.

568. Beyond the Red. If we wish to explore beyond the red we must use a sensitive detector of heat. Let us obtain the spectrum of the sun, and then through it, going from blue to red, pass an air thermoscope (Fig. 264), the bulb of which has been coated with lamp-black. The thermoscope will show a heating effect which increases as we go towards the red, but the heating does not cease there. Beyond the red the effect is

still pronounced. By means of special instruments heat waves 0.061 mm. long have been detected and measured. Such waves are about seven 'octaves' below the longest red waves.

Bodies at ordinary temperatures emit heat waves, and as the temperature is raised they give out, in addition, those waves which affect the eye.

569. Radiant Energy. These waves of various lengths are simply undulations of the ether. They are all forms of radiant energy. While passing from one place to another they all travel with the speed of light, and it is only when they fall upon some form of matter that their energy is transformed into those physical effects which we recognize as heat, light, and in other ways. It is to be observed that the space free from matter through which these waves pass is not heated by their passage.

Another form of radiant energy is seen in *electric waves*, referred to in the following sections.

570. Absorption and Radiation. When ether waves fall upon a body, more or less of their energy is *absorbed* and the temperature of the body rises. Some bodies have higher absorbing powers than others. A surface coated with lamp-black or platinum-black absorbs practically all the ether waves which fall upon it, and may be taken as a perfect absorber. On the other hand, a polished metal surface has a low absorbing power. Much of the ether energy which falls upon it is reflected from the surface instead of being absorbed by it.

This can easily be tested experimentally. Take two pieces of bright tin-plate about 4 inches square, and coat a face of one with lamp-black. Then stand them parallel to each other and about 5 inches apart. They may conveniently be supported in saw-cuts in a board, and the blackened face should be turned towards the other plate. Attach with wax a bullet

to the centre of the outer face of each plate. Now place midway between the plates a hot metal ball. Soon the bullet on the blackened plate will drop off while the other remains unaffected. If the blackened plate is touched with the finger it will be found unpleasantly hot, while the other one will show a comparatively small rise in temperature.

On the other hand, a blackened surface is a good radiator while a polished surface is a bad one. To show this experimentally use an apparatus like that illustrated in Fig. 567. It consists of two blackened bulbs connected to a U-tube in which is coloured water. Now place between the bulbs a well-polished vessel, one half of which is blackened, and fill it with hot water. On observing the change in the level of the coloured water it will be seen that the blackened surface is radiating much more heat than the polished half.

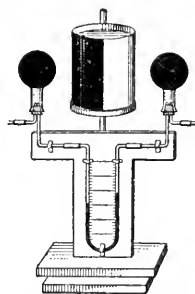

FIG. 567.--The blackened half of the vessel radiates more than the polished half.

QUESTIONS

1. Explain why a sheet of zinc protects woodwork from a stove better than a sheet of asbestos. Would bright tin-plate be better still?
2. A kettle to be heated by being hung before a fire-place should have one side blackened and the other polished. Why?
3. A sign consisted of gold-leaf letters on a board painted black. It was found, after a fire on the opposite side of the street, that the wood between the letters was charred while that under them was uninjured. Explain this phenomenon.
4. Why is a frost more to be feared with a clear sky than with a cloudy one?
5. Why is there a greater deposition of dew on grass than upon bare ground?
6. In the Sahara the cold at night and the heat by day are equally painful to bear. Explain why.
7. Covering a plant with paper often prevents it being frozen. Why?

571. Phenomenon of the Electric Spark. Let *A* and *B* (Fig. 568) be two knobs attached to an induction coil or an influence

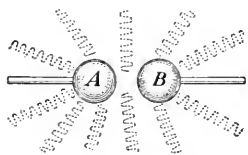

FIG. 568.—Diagram illustrating how the electric waves spread out from a spark-gap.

machine. On putting the apparatus in operation the potential of one knob rises until a spark passes between the knobs. Ordinarily one thinks simply that a quantity of electricity has jumped from one knob to the other in order to annul the difference of potential between *A* and *B*. But there is more in the phenomenon than that. As a matter of fact there is a rush across from *A* to *B*, then one back from *B* to *A*, then another from *A* to *B*, and so on, until the energy of the charge is dissipated. Thus, instead of a single spark there is a series of sparks between *A* and *B*. This has been demonstrated by photographing their images in a rapidly rotating mirror.

If a pail of water be quickly dumped into one end of a trough, the water rushes to the other end where it is reflected. It then returns to the first and is reflected. After travelling back and forth for some time the motion dies away through friction and the water all comes to the same level.

When a tuning-fork is vibrated, air-waves spread out in all directions, and if a unison fork is placed not too far away (Fig. 238) the incident waves will excite easily observed vibrations in it (see § 229).

In a similar way the electrical surgings from knob to knob excite a disturbance in the surrounding ether, and ether-waves spread out in all directions (indicated by the wavy lines in Fig. 568).

572. Sympathetic Electrical Oscillations. It is possible to exhibit electrical resonance quite analogous to that obtained with the unison tuning-forks. Let us take two precisely similar Leyden jars *A* and *B* (Fig. 569), and let a wire run from the outer coating of *A* and end in a knob *c'* near to the knob *c* which is attached to the inner coating. Join these knobs to an influence machine or an induction coil.

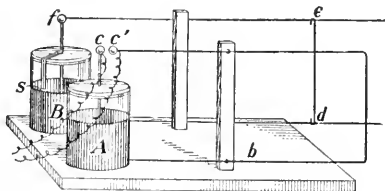

FIG. 569.—Arrangement to show electrical resonance.

Also let the inner and outer coats of *B* be connected by a wire loop *Bdef*, the portion *de* being so arranged that by sliding it along the other wires the area inclosed by the wire *Bdef* may be made equal to that of the fixed loop on the other jar. From the inner coating of *B* a strip of tin-foil is brought down to *s* within about 1 mm. of the outer coating.

Now cause sparks to pass between the knobs *c*, *c'*. Then if the two wire loops are equal in area there will be a little spark at *s* whenever a spark passes at *c*, *c'*. If the wire *de* is slid back or forth the equality of the areas will be destroyed and the sparks will cease at *s*.

When the spark passes at *c*, *c'* there are electrical surgings back and forth between the outer and inner coatings of *A*. These cause disturbances in the surrounding ether which spread out and set up oscillations in the similar circuit attached to the other jar. The *natural period* of the two circuits must be equal (or nearly so) for the sympathetic oscillations to be set up.

In such an arrangement as here described the number of oscillations is ordinarily several millions per second.

573. Electric Waves. As early as 1864 Maxwell*, by mathematical reasoning based on experimental results obtained by Faraday, showed that electric waves in the ether must exist; but they were first detected experimentally by Hertz,† a young German physicist. Hertz showed that they are real ether-waves travelling through space with the speed of light, that they can be reflected and refracted, and that they also possess other properties similar to those possessed by light-waves.

It is now firmly established that the short photographic waves, the waves which produce the colours of the spectrum, the longer heat-waves and the still longer electric waves are all of the same nature. They are all undulations of the ether, differing only in wave-length.

574. The Coherer. Various methods besides that illustrated in § 572 have been devised for detecting the presence of electric waves. The simplest of these is the *coherer*. Let us take a glass tube 6 or 8 inches long and $\frac{1}{2}$ inch in diameter, fill it loosely with turnings of cast-iron or other metal, and through corks in each end insert copper wires.

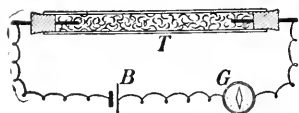

FIG. 570.—*T* is a tube filled with iron turnings, *G* is a galvanometer and *B* a battery.

Then join the tube in series with a dry cell *B*, and a sensitive galvanometer *G* (Fig. 570). Ordinarily the resistance of the turnings is so high that the needle of the galvanometer is not noticeably deflected. If now an influence machine be

operated in the neighbourhood the galvanometer at once shows a deflection. The bits of metal, when the electric waves aroused by the machine fall upon them, appear to *cohere*, the resistance at once decreases and a current flows through the galvanometer.

* James Clerk Maxwell, a very distinguished physicist. Born in Scotland 1831, died 1879.

† Heinrich Hertz died on January 1, 1894, in his 37th year.

By simply tapping the tube the filings are decohered and are ready for action again.

In the coherer shown in Fig. 571 the tube is about 3 inches long and has an internal diameter of about $\frac{1}{8}$ inch. The plugs *P, P* snugly slide in the tube, and a small amount of filings is placed between them. Marconi has used a mixture of 95 per cent. nickel and 5 per cent. silver.

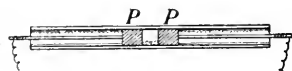

Fig. 571.—A form of coherer introduced by Marconi.

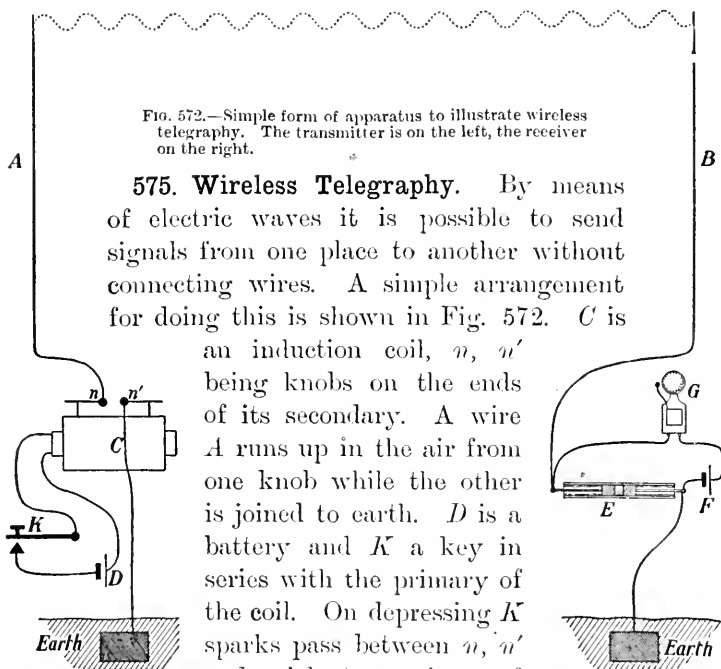

Fig. 572.—Simple form of apparatus to illustrate wireless telegraphy. The transmitter is on the left, the receiver on the right.

575. Wireless Telegraphy. By means of electric waves it is possible to send signals from one place to another without connecting wires. A simple arrangement for doing this is shown in Fig. 572. *C* is an induction coil, *n, n'* being knobs on the ends of its secondary. A wire *A* runs up in the air from one knob while the other is joined to earth. *D* is a battery and *K* a key in series with the primary of the coil. On depressing *K* sparks pass between *n, n'* and violent surgings of electricity up and down *A* are produced. These excite disturbances in the surrounding ether, the energy of which is carried by ether-waves in all directions.

At some distance away is the receiving apparatus. E is a coherer. From one pole of it a wire B runs up in the air; from the other pole a wire leads to earth. In circuit with the coherer are a battery F and an electric bell G . The electric waves travel from A with the speed of light and on reaching B they excite oscillations in it. These cause the resistance of the coherer to fall, and the bell responds.

576. Arrangement of the Receiving Apparatus. In actual experimenting the simple receiving apparatus shown in Fig. 572 is not satisfactory. A better arrangement is illustrated in Fig. 573.

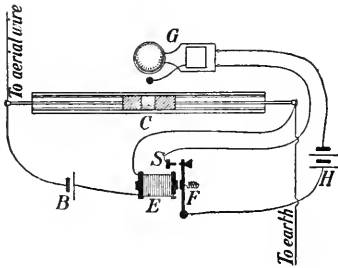

Fig. 573.—Receiving apparatus for wireless telegraphy.

The coherer C is joined in series with a battery B and a sensitive relay E (§ 510). When the resistance of the coherer falls, the armature F of the relay is drawn over against the stop S . This completes a circuit, in which are the battery H and the electric bell

G , which is so placed that the hammer, besides striking the bell, taps the coherer and decoheres the filings, making them ready for another signal.

For sending signals across a room or from one room to another only a small coil and wires but a few feet high are required; but if the distance to be covered is great very powerful transmitters and very delicate receivers must be used.

Wireless telegraphy is very useful in communicating signals from the shore to a ship or from one ship to another. By means of it many lives and much property have been saved.

577. Passage of Electricity through Gases. In investigating this subject the gas is usually contained in a glass tube (Fig. 574) into the ends of which platinum wires are sealed.

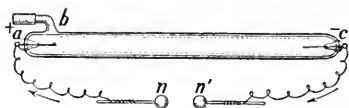

FIG. 574.—Arrangement to study the passage of electricity through a gas.

The terminals n , n' of an induction coil are joined to a and c , the electrodes of the tube. Let the electricity enter the tube at a and leave at c ; these are, then, the *anode* and *cathode*, respectively. Sometimes one electrode has an aluminium disc upon it. By connecting a side tube b to a good air-pump the air can be exhausted from the tube.

At first, when the air in the tube is under ordinary atmospheric pressure, the discharge passes between n and n' , but as the pressure is reduced it begins to pass between a and c ; and as the exhaustion is continued some very beautiful effects are produced.

If, however, the exhaustion is pushed still further, until the pressure within the tube is about one millionth of an atmosphere, phenomena of a different class are produced. As Sir William Crookes was the first to study these phenomena in great detail, these very highly exhausted tubes are known as Crookes Tubes.

From the cathode something is shot off which travels through the tube in straight lines and with great speed. This has been shown to consist of very small particles charged with negative electricity, and the streams of these particles are known as *cathode rays*.

578. Röntgen Rays. In 1895, Röntgen, a German physicist, while experimenting with Crookes tubes, discovered a new kind of radiation, which he called X-rays, but which is more often known as Röntgen rays.

In Fig. 575 is shown a tube suitable for producing the Röntgen rays. The electrodes *a* and *c* are joined to a large induction coil. From the concave surface of the cathode *c* the cathode rays are projected, and when they strike the platinum plate *m* (or any other solid body) they give rise to the Röntgen rays, which spread out as shown in the figure, easily passing through the walls of the tube.

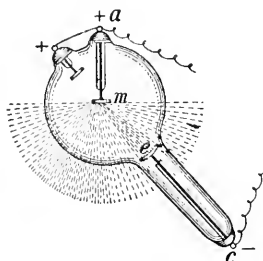

Fig. 575.—A Röntgen ray tube.

579. Photographs with Röntgen Rays. The Röntgen rays can affect a photographic plate just as light does. They can also pass through substances quite opaque to light, such as wood, cardboard, leather, flesh, but they do not so easily penetrate denser substances such as lead, iron and brass. If the hand be held close to a photographic plate and then exposed to the Röntgen rays, the rays easily pass through the flesh but are considerably hindered by the bones. Consequently when the plate is developed that part which was behind the flesh is much more blackened than that behind the bones. When a print is made from the 'negative' we obtain a picture like that in Fig. 576.



Fig. 576.—From an X-ray photograph of the human hand.

In place of a photographic plate we may use a paper screen coated with crystals of barium-platino-cyanide. When the rays fall upon this it shines with a peculiar yellow-green shimmering light. It is said to *fluoresce*. The shadow of an opaque body is clearly seen by this light.

580. Other Properties of the Röntgen Rays. If the hand or any other portion of the body is continually exposed to the Röntgen rays serious injury may result.

Another striking characteristic of the rays is their ability to discharge an electrified body. If the air is thoroughly dry a well-insulated electroscope (§ 445) will hold its charge for many hours; but if it is placed in the path of the Röntgen rays the charge at once leaks away. For this to take place the air surrounding the gold leaves must become a conductor of electricity.

581. Conduction of Electricity through Air. It is believed that electricity is conducted through a gas much as it is through a liquid. The latter was explained in § 484.

Let *C* and *D* (Fig. 577) be two parallel metal plates placed a few cm. apart, and let *C* be joined to one pole of a battery, the other pole being joined to earth. *E* is an electrometer. This is a delicate instrument which measures the electrical charge given to it. First, suppose the tube *T* not to be in action;

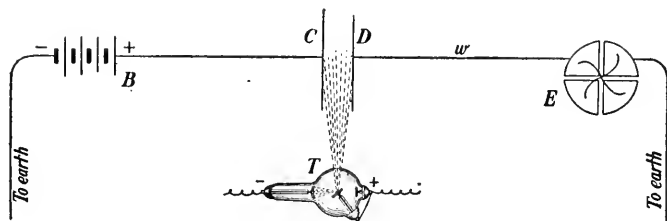

FIG. 577.—An arrangement to exhibit the conduction of electricity by air. The X-rays ionize the air.

the needle of the electrometer will be at rest. Then let the tube be started, and let the Röntgen rays pass into the air between the plates *C* and *D*. At once the electrometer begins to receive a charge, showing that electricity has passed across from *C* to *D* and thence by the wire *w* to the electrometer.

When the X-rays pass through a gas they cause the molecules of the gas to be broken up into positively and negatively charged carriers of electricity called *ions*. This process is called *ionization*. When a molecule is ionized it is broken up into two ions, the electrical charges of which are equal in

magnitude but of opposite sign. The positive ions are repelled from *C* to *D* and the negative ions are attracted by the plate *C*. In this way the electricity is transferred from *C* to *D*.

582. Radio-activity. In 1896, a French physicist named Becquerel discovered that the element uranium and its various compounds emitted a radiation which could affect a photographic plate; and soon afterwards it was shown that, like the X-rays, it could ionize the air. A little later it was discovered that thorium and its compounds acted in the same way. Thorium is the chief constituent of Welsbach mantles. All such bodies are said to be *radio-active*.

In searching for other radio-active bodies, Madame Curie observed that pitchblende, a mineral containing uranium, was more radio-active than pure uranium. After a very laborious chemical research she succeeded in separating from several tons of pitchblende a few milligrams of a substance which was more than a million times as radio-active as uranium. To this substance the name of *radium* was given.

In experimenting pure radium is not used, but radium bromide. Other radio-active substances have been discovered, *polonium* and *actinium* being the names given to two of the most powerful.

It is easy to illustrate radio-activity. Lay some crystals of a salt of uranium or thorium (uranium nitrate or thorium nitrate, for instance,) upon a photographic plate securely wrapped in black paper and allow them to remain there for some hours. When the plate is developed it will be found to be fogged. Or if the substance be held near a charged electro-scope the charge will at once leak away.

583. Different Kinds of Rays. Rutherford has shown that there are three types of rays emitted by radio-active bodies (see §167). These he named the α (alpha), the β (beta) and the γ (gamma) rays. The α rays are powerful ionizers of a

gas, and it is now believed that the α particles are positively-charged atoms of helium. It takes very little to stop them. A sheet of aluminium $\frac{1}{2}$ mm. thick completely cuts them off. The β rays are much more active photographically than the α rays, but not so powerful in ionizing a gas. They consist of negatively-charged particles and behave much like cathode rays. The γ rays can pass through great thicknesses of solid matter, but their precise nature has not yet been determined. They resemble Röntgen rays.

During recent years investigations into radio-activity have led to new views regarding the nature of atoms, regarding the relations between electricity and matter, and regarding the manner in which one substance is disintegrated and another is formed.

ANSWERS TO NUMERICAL PROBLEMS

PART I—INTRODUCTION

Page 7. 1. 2,500,000 mm. 2. 299,804.97 km. 3. 32,400,000 sq. cm.
4. 29.921 in. 5. 1 cu. m. = 1,000 l. = 1,000,000 c.c. 6. 183.49 m. 7. 65.4 cents. 8. 9697.5 kg. 9. The former. 10. 4.79 mm.

Page 16. 1. 1.47 kg. 2. 54.05 c.c. 3. 519.75 grams. 4. 21.59; 46.318 c.c.
5. 2.7 grams per c.c. 6. 12 kg. 7. 0.77 gm. per c.c. 8. 1.99 mm. 9. 283.5, 0.5, 1.9, 7.1, 14.3 grams; 1814.4, 453.6, 141.7, 14.2, 85.0, 28.3 grams. (Correct to first decimal place; accurate enough for photography).

PART II—MECHANICS OF SOLIDS

Page 19. 1. 88 ft. per sec. 2. 108 km. per hr. 3. 11 miles per day.
4. 1 mile per day.

Page 20. 1. $2\frac{1}{4}$ cm. per sec. per sec. 2. $-1\frac{1}{2}$ ft. per sec. per sec. 3. 32.185 ft. per sec. per sec.

Page 27. 1. 4 ft. per sec. 2. 1000 cm. per sec. 3. 576 ft. or 176.4 m.
4. 190 cm. per sec. 5. 128 ft. per sec. 6. 7.82 sec; 4.37 sec. (approx.).
7. $759\frac{3}{8}$ ft.; $33\frac{3}{4}$ sec. 8. $\frac{1}{2}$ ft. per sec. per sec. 9. 4 sec.; 1 sec.; 78.4 m.
10. 144 ft. or 44.1 m. 11. 15 sec. 12. Yes; $29\frac{1}{3}$ ft. to spare.

Page 31. 2. 14, 8, 11.4 ft. per sec. 4. 62.45 cm. per sec.; 68.06 cm. per sec. 5. 7.55 ft. per sec.

Page 34. 3. 125 : 3.

Page 39. 1. 5 cm. per sec. per sec.; 25 cm. per sec.; 10,000 units. 2. 5 grams; 2 cm. per sec. per sec. 3. 200 dynes. 4. 75 ft. per sec.; 5 ft. per sec. per sec.; 750 units.

Page 41. 2. 1,250 m. per sec. 3. 19.6 m. per sec.; 1,250.15 m. per sec.

Page 43. 4. 11.72 (nearly) ft. per sec.

Page 46. 1. $16\frac{1}{4}$ pounds. 3. 3 feet.

Page 53. 1. Doubled. 2. $44\frac{1}{2}$, 25, 16 kg. 3. 0.37 pounds.

Page 56. 1. 100,000 ergs. 2. 1,800 ft.-pds. 3. 50,000 ft.-pds. 4. $\frac{1}{2}\frac{1}{8}$ kg.-m. 5. 150,000 ft.-pds. 6. 528,000 ft.-pds.

Page 63. 5. 5 ft.

Page 66. 3. 45 pounds.

Page 70. 1. $1\frac{1}{4}$ pounds. 2. 90 pounds, 120 pounds. 3. $37\frac{1}{2}$ pounds.
4. 225 pounds.

Page 73. 1. Twice as great; twice as long. 2. 4. 3. $\frac{1}{3}$. 4. 60 pounds.

Page 77. 1. $26\frac{2}{3}$ pounds. 2. 6,400 pounds.

Page 80. 2. $20\frac{1}{5}$ pounds. 3. $4\frac{1}{2}$ pounds. 4. $\frac{1}{12}$ pound; $\frac{1}{32}$ pound.

PART III—MECHANICS OF FLUIDS

Page 91. 1. $312\frac{1}{2}$ g. 2. 800 kg. 3. 11,550 pounds. 4. 10,000. 5. 36 kg. 6. 184.87 ft. nearly.

Page 94. 1. 62.3 pounds (at 62° F.); 97.7 pounds. 2. 4.57 pounds. 3. 2.5 kg. 4. 4.9 kg. 5. 600 g. 6. $\frac{1}{4}$. 7. 1,557.5 pounds. 8. $133\frac{1}{3}$ c.c. 12. 22.3 pounds.

Page 99. 1. $\frac{3}{7}$ g. per c.c. 2. $\frac{1}{4}$ g. per c.c. 3. 1.2 g. per c.c. 4. $\frac{3}{8}$ g. per c.c. 5. 20 c.c.; 6 g. per c.c.; 0.8 g. per c.c. 6. $\frac{8}{9}$ g. per c.c. 7. S.g. = $\frac{5}{8}$; s.g. = $\frac{5}{8}$; $6\frac{1}{4}$ inches. 8. 1.072 (nearly) g. per c.c. 9. Gold, 386.4 g.; silver, 21.04 g.

Page 104. 6. 1.291 g.

Page 115. 1. $6\frac{3}{8}$ c. ft. 2. 22.85 l. 3. 75,314.7 c. in. 4. $483\frac{1}{3}$ in. of mercury. 5. $562\frac{1}{2}$ mm. 6. 174 in. of mercury. 7. 0.0001259 (nearly) per c.c. 8. 101.34 g. 9. \$3.60.

Page 118. 4. 2908.75 kg.

Page 128. 1. $\frac{3}{8}$; $\frac{8}{27}$. 2. $\frac{4}{5}$. 3. $1\frac{1}{2}$. 4. 12.92 m.

Page 130. 1. (b) 13.6 times ht. of mercury barometer. 2. $219\frac{1}{5}$ in.

PART V—WAVE-MOTION AND SOUND

Page 178. 1. 335, 338, 356 m. per sec. 2. 1024.3 ft. per sec. 3. 5,595 ft. 4. 3,490.2 ft. 5. 3.81 sec. (nearly). 9. 1,678.5 ft. 10. 4,707.4 ft. per sec. 11. 11,404 ft. per sec. ($t = 20^\circ$ C.). 12. 4,290.2 ft. per sec.

Page 186. 2. 400, 500. 3. 2,685.6. 5. 4,698. 6. $32\frac{5}{8}$, $65\frac{1}{4}$, $130\frac{1}{2}$, 261, 522, 1,044, 2,088, 4,176. 7. 271.2. 8. G' , E'' . 9. 69.2, 46.1, 31.1, 20.8 in. (approx.).

Page 198. 5. 6.49 in. 6. 4,064 m. per sec. 7. 36 pounds. 9. $\sqrt{2}$: 1. 10. 10.38 in. if closed at one end; 20.76 in. if open.

Page 207. 1. C' , E'' counting C as the first.

PART VI—HEAT

Page 228. 1. 9, 32.4, 48.6, 117. 2. $11\frac{1}{2}$, 15, 20, $52\frac{5}{8}$. 3. 117. 4. $15\frac{5}{8}$. 5. $-17\frac{7}{8}$, $-12\frac{3}{8}$, 0° , $7\frac{3}{8}$, $37\frac{7}{8}$, $-31\frac{3}{8}$, -40° . 6. 50° , 68° , 89.6° , 167° , -4° , -40° , -459.4° . 7. $38\frac{3}{8}$ cent. deg. 8. (a) 9.6° , -8° , -12° , $1\frac{7}{8}$. (b) 20° C., 68° F.; $31\frac{1}{4}$ C., $88\frac{1}{4}$ F.; $-7\frac{1}{2}$ C., $18\frac{1}{2}$ F.

Page 232. 1. 4.0002 ft. 2. 1.000 342 m. 3. 120.0216 sq. in. (nearly). 4. 57.69 cm. (nearly). 5. 762.84 mm.; 762.55 mm. 6. 761.07 mm.

Page 236. 3. 28.55 l. 4. 107.59 c.c. (nearly). 5. 155.1 pds. per sq. in. 6. 17.53 pds. per sq. in. (nearly). 7. 1.127 g. (nearly). 8. $32^\circ.8$ C., $-22^\circ.8$ C. 9. 27.3° C. 11. 108.87 l. (nearly). 12. $322\frac{3}{8}$ c.c. 13. 0.837 g. 14. 0.0000760 g. per cm. (nearly).

Page 239. 1. 1,625 cal. 2. 3,000 cal. 3. 23° C. 4. 10 cent. deg. 5. $66\frac{1}{2}^\circ$ C.

Page 242. 1. 5.6 cal. 2. Mercury, 2.244 cal.; water, 2 cal. 3. 36 cal. 4. 0.094. 5. 0.694. 6. 9,600 cal. 7. 950.16 cal. 8. 226,000 cal. 9. 27.9 cal. 10. 3.17° C. (nearly). 11. Sp. ht. 0.113 (nearly); iron. 12. 0.113 (nearly). 13. 30,225 cal. 14. 47.0° C. (nearly). 15. 0.748.

Page 247. 6. 2,800 cal. 7. 1,200,000 cal. 8. $59\frac{1}{11}^{\circ}$ C. 9. $1,111\frac{1}{3}$ grams.
 10. 80 grams. 11. 2,185 cal. 12. 166.15 grams. 13. 12.05 (nearly) grams.
 14. 0.09. 15. 79.38.

Page 255. 5. 19,832 cal. 6. 182,240 cal. 7. 27,945 cal. 8. 230,680 cal.
 9. 44.37° C. 10. 10.07 g. (nearly). 11. 3.14 g. 12. 21,705 cal. 13.
 432,500 cal. 14. 536.4 cal. per gram (nearly).

Page 273. 1. (a) 2,500 ft.-pds. ; 3.21 B. T. U. 2. 3,736,250 l. 3.
 2,388.34 cal. 4. 77,763.5 B. T. U. 5. 78.064 kg. 6. 1,038.77 lbs.

PART VII—LIGHT

Page 293. 1. 2.4 inches. 5. 869,159 ; 5,791 miles (nearly). 6. 105.4 miles.

Page 299. 2. 4:25. 3. 25:9. 4. 14.15 c.p. 5. 4 ft. 6. 2 ft. from the
 candle towards the gas-flame and 6 ft. from the candle in opposite direction.

Page 308. 2. 60° . 5. 40, 80, 120 inches.

Page 318. 5. 15 cm. from vertex, in front of mirror ; 2.5 cm. high. 6. 40
 cm. from vertex, behind mirror ; 25 cm. high. 7. 10 cm. from vertex, behind
 mirror ; virtual ; 4 cm. high.

Page 329. 1. 0.405 nearly. 2. 139,500 mi. per sec. ; 124,000 mi. per sec. ;
 9/8. 8. $40\frac{1}{2}^{\circ}$. 9. 1.52.

Page 355. 4. 30 cm.

PART VIII—ELECTRICITY AND MAGNETISM

Page 418. 3. 3,049 sec. (nearly). 4. 5 amp. 5. H, 0.10384 g. ; O, 0.83072 g. ;
 Cu., 3.28 g.

Page 451. 6. 80 per sec.

Page 463. 1. $\frac{1}{8}$ amp. 2. $\frac{1}{2}$ amp. 3. 208 ohms. 4. 0.19 ohm. 5. 22
 volts. 6. 13.5 volts. 7. 10 amp. 8. 3 ohms.

Page 464. 1. $8\frac{1}{2}$ amp ; 80 volts. 2. $\frac{1}{2}$ amp. ; 4 m. 3. 1 volt, 1 volt,
 102 volts. 4. 113 volts. 5. $1\frac{1}{2}$ amp., $\frac{2}{5}$ volt. 6. $\frac{3}{4}$ volt, $\frac{2}{5}$ volt.

Page 467. 1. 360,000 coulombs. 2. 45,000,000 joules. 3. 13.75 K.W. =
 13.43 H.-P. 4. 103,680 cal. 5. 1 c.p. per watt. 6. 99,840 watt-hours ; \$7.99.

Page 471. 1. 3.13 ohms. 2. 0.9407 ohms. 3. 72 ohms. 4. 20.31 ohms.
 5. 22.5 m. 6. 135.9 yds. 7. 0.6 mm. 8. 2.653 mm. 9. 1,080 yds. 10. 3.04.
 11. 20.1 ohms ; 75.84 ohms.

Page 474. 1. $6\frac{2}{3}$ ohms ; $\frac{2}{3}$, $\frac{1}{3}$. 2. $8\frac{1}{2}$ ohms ; $4\frac{2}{3}$ ohms. 3. 4 ohms. 4. 100
 ohms. 5. $2\frac{1}{2}$ amp. ; $1\frac{1}{2}$ amp. ; 48 ohms. 6. 100 ohms. 7. $\frac{1}{n+1}$. 8. 9:25.

Page 478. 1. 3 amp. 2. $1\frac{1}{3}$ amp. ; $1\frac{2}{3}$ amp. ; $2\frac{2}{3}$ amp. 3. $\frac{1}{2}$ amp. in each
 case. 5. 50 cells. 6. Let n =No. of cells in a group, m =No. of groups in
 parallel. For $n=1$, $m=48$, $C=0.071$ amp., $P.D.=0.009$ volt ; $n=2$, $m=24$,
 $C=0.138$, $P.D.=0.069$; $n=3$, $m=16$, $C=0.199$, $P.D.=0.224$; $n=4$, $m=12$,
 $C=0.252$, $P.D.=0.504$; $n=6$, $m=8$, $C=0.329$, $P.D.=1.48$; $n=8$, $m=6$,
 $C=0.372$, $P.D.=2.98$; $n=12$, $m=4$, $C=0.389$, $P.D.=7.00$; $n=16$, $m=3$,
 $C=0.364$, $P.D.=11.69$; $n=24$, $m=2$, $C=0.295$, $P.D.=21.24$; $n=48$, $m=1$,
 $C=0.169$. $P.D.=48.67$. 7. 0.75 volt.

INDEX

A

- Aberration, 310 ; chromatic, 347.
Absolute temperature, 234.
Absorption, of light, 341 ; of radiant energy, 480.
Acceleration, definition of, 20 ; uniform, 20.
Accelerations, composition of, 32.
Accumulators, 415.
Achromatic lenses, 346.
Actinium, radio-activity of, 490.
Adhesion, 142.
Agonic line, 376.
Air, weight of, 101 ; pressure of, 101 ; variations in pressure of, 107 ; compressibility and expansibility of, 112 ; the uses of compressed, 123.
Air-brakes, 124.
Air-pump, 119 ; the Geryk, 120 ; the mercury, 121 ; the Bunsen jet, 121.
Alternating current, uses of, 452.
Alternating current dynamo, 444.
Ammeters, 432.
Ampere, the international, 463.
Ampère's laws of currents, 424.
Aperture of mirror, 309.
Archimedes' principle, 93.
Arc lamp, 459 ; the inclosed, 460 ; regulation of, 461.
Armature, of a dynamo, 443 ; shuttle, 443 ; Gramme-ring, 444 ; drum, 444.

- Artesian wells, 90.
Atmosphere, variations and pressure of, 107 ; height of the, 111.
Automobile 'honk,' 211.
Axis of mirror, 309.

B

- Balance, description of, 11.
Balloons, 117.
Barometer, the, 105 ; the cistern, 105 ; the siphon, 106 ; the aneroid, 106 ; practical uses of, 107.
Beats, 203 ; tuning by means of, 205.
Bell, electric, 430.
Boiling point, 251 ; effect of pressure on, 251.
Boyle's law, 113 ; explanation of, 135.
Brittleness, 146.
Bugle, 212.
Buoyancy, nature of, 92 ; to determine force of, 93 ; of gases, 116.

C

- Caissons, pneumatic, 125.
Camera, the pin-hole, 290 ; the photographic, 359.
Capacity, electrical, 390.
Capillary action, 152 ; explanation of, 154 ; illustrations of, 155.

- Cell, the voltaic, 396 ; Leclanché, 405 ; Daniell, 405 ; gravity, 406 ; the dry, 407 ; Edison-Lalande, 407.
- Centre of curvature of mirror, 309.
- Centre of gravity, definition of, 60 ; to find, experimentally, 60 ; of some bodies of simple form, 61.
- Charges, induced, equal, 385 ; reside on outer surface, 386.
- Charles' law, 232, 235.
- Chords, musical, 182, 184.
- Clarinet, 211.
- Clouds, 264.
- Coefficient, of expansion of solids, 229 ; of expansion of liquids, 230 ; of expansion of gases, 232.
- Coherer, the, 484.
- Cohesion, 142.
- Cold storage, 258.
- Colladon's fountain of fire, 327.
- Colours, by dispersion, 339 ; of natural objects, 341.
- Complementary colours, 345.
- Compressed air, uses of, 123.
- Condensation of water-vapour of the air, 261.
- Condenser, the air, 123 ; the steam, 269 ; electrical, 391.
- Conduction of heat, 274 ; in solids, 274 ; in liquids, 275 ; in gases, 276 ; practical significance of, in bodies, 276.
- Conductors, electrical, 381.
- Conjugate foci, of mirror, 313 ; of lens, 333.
- Conservation of mass and energy, 58.
- Convection currents, 279 ; in gases, 280 ; applications of, 281.
- Cooling by vaporization, 256, 257.
- Cornet, 212.
- Coulomb, 465.
- Couple, 46.
- Critical angle, 326 ; values of, 326.
- Critical temperature, 259.

D

- Daniell's cell, 405.
- D'Arsonval galvanometer, 432.
- Declination, magnetic, 376.
- Densities, table of, 14.
- Density, definition of, 13 ; measurement of, 14 ; relation to specific gravity, 15 ; of a solid heavier than water, 96 ; of a lighter than water, 97 ; of a liquid by the specific gravity bottle, 97 ; of a liquid by Archimedes' principle, 98 ; of a liquid by means of a hydrometer, 98.
- Dew, 264.
- Dew-point, 261.
- Diatonic scale, 183.
- Diffusion, of gases, 133 ; of liquids and solids, 134.
- Dip, magnetic, 378.
- Direct current dynamo, 446.
- Direct vision, 350.
- Dispersion of light, 339.
- Displacement, definition of, 18 ; resultant, 18 ; component, 18.
- Distillation, 265.
- Diving bells and diving suits, 124.
- Doppler's principle, 207.
- Dry cell, 407.
- Ductility, 146.
- Dynamo, the principle of, 442 ; the armature of, 443 ; field magnets of, 444 ; the alternating current, 444 ; direct current, 446.
- Dyne, the, 38.

E

Earth, a magnet, 375 ; magnetic field about, 378.

Ebullition, 248, 251.

Echoes, 175.

Edison-Lalande cell, 407.

Efficiency of heat engines, 272.

Elasticity, definition of, 143 ; measurement of, 143 ; of various metals, 144.

Electricity, nature of, 389 ; quantity of, 465 ; passage of, through gases, 487.

Electrical, attraction, 380 ; repulsion, 381 ; law of attraction and repulsion, 381 ; potential, 388 ; capacity, 390 ; condenser, 391.

Electrical units, 462.

Electric bell, 430.

Electric circuit, explanation of terms, 400 ; work done in, 466.

Electric current, nature of the, 396 ; known by its effects, 396 ; detection of, 403 ; heat developed by, 457.

Electric furnace, 457.

Electric lamps, 458, 459.

Electric motor, 449 ; counter electromotive force in, 450.

Electric spark, phenomenon of, 482.

Electric telegraph, 427.

Electric waves, 484.

Electric welding, 458.

Electrification, kinds of, 381 ; by induction, 383.

Electrolysis, 403 ; explanation of, 408 ; secondary reactions in, 411 ; of water, 411 ; applied to manufactures, 413 ; laws of, 416 ; measurement of current strength by, 416

Electromagnet, 423 ; strength of, 424.

Electromotive force, 401 ; unit of, 401 ; of a voltaic cell, 402.

Electrophorous, the, 393.

Electroplating, 412.

Electroscope, the gold-leaf, 382.

Electrotyping, 413.

Energy, definition of, 56 ; transformations of, 57 ; measurement of, 57 ; conservation of, 58.

Equilibrium, conditions for, 62 ; three states of, 62.

Erg, the, 55.

Ether, 288.

Evaporation, 248 ; rate of, 248 ; molecular explanation of, 249 ; into air, 250 ; cold by, 256.

Expansion, of solids by heat, 217 ; of liquids and gases by heat, 218 ; applications of, 218 ; coefficient of, of solids, 229 ; coefficient of, of liquids, 230 ; of water, 231 ; coefficient of, of gases, 232.

Eye, construction of the, 356 ; image on the retina of, 357 ; accommodation of, 357 ; defects of, 358.

F

Faraday's experiments, 435.

Field glass, 365 ; the prism binocular, 366.

Field magnets, of a dynamo, 444 ; excitation of, 448.

Field of force, 370 ; due to electric current, 419 ; about a circular conductor, 420.

Flotation, principle of, 94.

Flute, 210

Focal length of mirror, 310 ; determination of, 311.
 Focus of mirror, 310.
 Fog, 264.
 Force, definition of, 36 ; units of, 37 ; gravitation units of, 39 ; moment of a, 44.
 Forces, composition and resolution of, 40 ; composition of parallel, 45 ; parallelogram of, 47 ; triangle of, 48 ; polygon of, 48 ; at the surface of a liquid, 150.
 Freezing mixtures, 247.
 French horn, 212.
 Friction, definition of, 64 ; laws of sliding, 65 ; rolling, 65.
 Frost, 264.
 Fusion, 243 ; change of volume in, 244 ; heat of, 245.

G

Galvanometer, 431 ; the tangent, 431 ; the D'Arsonval, 432.
 Galvanoscope, 403.
 Gases, buoyancy of, 116 ; diffusion of, 133.
 Gas engines, 270.
 Gas thermometer, 234.
 Gay-Lussac's law, 232.
 Gravitation, law of, 50.
 Gravity cell, 406.

H

Hail, 264.
 Hardness, 146.
 Harmonics, 186 ; in a string, 190 ; in an organ pipe, 197.
 Heat, nature of, 214 ; source of, 215 ; unit of, 238 ; specific, 239 ; given out in solidification, 246 ; absorbed in solution, 247.

Heating, by hot water, 282 ; by steam, 283 ; by hot-air furnaces, 283.
 Heat of fusion, 245 ; determination of, of ice, 246.
 Heat of vaporization, 254 ; determination of, 254.
 Helix, magnetic conditions of a, 421 ; polarity of the, 422.
 Hooke's law, 144.
 Horse-power, 59.
 Hot-water heating, 282.
 Humidity, 262 ; relation of, to health, 263.
 Hydraulic air compressor, the Taylor, 121.
 Hydraulic elevator, the, 84.
 Hydraulic lift-lock, the, 86.
 Hydraulic press, the, 84.
 Hydrometer, the, 98.
 Hydrostatic paradox, 88.
 Hygrometer, 263.

I

Ice-making machine, 258.
 Images, in plane mirror, 302, 306 ; in parallel mirrors, 307 ; in inclined mirrors, 307 ; to draw, in curved mirrors, 314 ; relative sizes of image and object in curved mirrors, 315 ; to draw, in lenses, 337.
 Incandescent electric lamp, 458.
 Inclination, magnetic, 378.
 Inclined plane, the, 77.
 Induced currents, production of, 436 ; illustrations of, 436 ; laws of, 438.
 Induced magnetism, 369.

Induction, magnetization by, 369 ;
 electrification by, 383 ; electrical
 charging by, 385.
 Induction coil, 453 ; explanation of
 the action of, 454.
 Inertia, definition of, 33.
 Intensity, of sound, 172 ; of light,
 294.
 Interference of sound-waves, 205 ;
 with resonators, 206.
 Intervals of the major diatonic
 scale, 183.
 Isogonic lines, 376.

J

Joule, the, 267, 466.

K

Kaleidoscope, 307.
 Kilogram, standard, 8 ; prototype, 9.

L

Lantern, the projection, 360.
 Latent heat, 245.
 Lateral inversion by a mirror, 306.
 Leclanché cell, 405.
 Length, standards of, 2.
 Lens, 330 ; principal axis of, 330 ;
 action of, 330 ; focus of, 331 ;
 focal length of, 331 ; power of,
 331 ; determination of focal length
 of, 331 ; conjugate foci of, 333 ;
 magnification by, 338.
 Lenses, kinds of, 330 ; combina-
 tions of, 332 ; achromatic, 346
 Lenz's law, 439.
 Lever, the first class, 67 ; second
 class, 68 ; third class, 70.
 Leyden jar, 392.

Light, radiation, 287 ; how trans-
 mitted, 287 ; waves and rays of,
 289 ; travels in straight lines,
 290 ; determination of velocity
 of, 300, 301 ; illustrations of velo-
 city of, 301 ; velocity in liquids
 and solids, 301 ; laws of reflec-
 tion of, 302 ; refraction of, 319 ;
 laws of refraction of, 322 ; total
 reflection of, 325 ; dispersion of,
 339 ; absorption of, 341.

Lightning rods, 387.

Lines of force, properties of, 372.

Liquid, surface of, in connecting
 tubes, 89 ; diffusion of, 134 ;
 distinction between liquids and
 solids, 141.

Liquefaction of air, 260.

Local action in a cell, 404.

Loops, 166 ; in a vibrating string,
 189.

Luxfer prisms, 327.

M

Machine, object of a, 67.

Magnet, natural, 367 ; artificial,
 367 ; poles of a, 367 ; retentive
 power of, 370 ; field of force
 about, 370 ; the earth a, 375.

Magnetic, laws of, attraction and
 repulsion, 368 ; substances, 369 ;
 shielding, 372 ; permeability, 373 ;
 declination, 376 ; inclination, 378.

Magnetism, induced, 369.

Magnetization, explanation of, 373 ;
 effects of heat on, 375.

Magnification by lens 338.

Malleability, 145.

Mariner's compass, 375.

- Mariotte's law, 115.
- Mass, standards of, 7 ; definition of, 7, 33.
- Matter, molecular theory of, 131.
- Maximum density of water, 231.
- Maximum thermometers, 227.
- Measurement, of a quantity, 2 ; of length, 10 ; of mass, 11 ; of density, 14 ; of acceleration due to gravity, 24 ; of weight, 51 ; of work, 55 ; of energy, 57 ; of elasticity, 143 ; of current strength, 416.
- Mechanical equivalent of heat, determination of, 267.
- Melting point, 243 ; influence of pressure on, 244.
- Metre, the standard, 3 ; the prototype, 4 ; sub-divisions of, 6 ; relation to yard, 6.
- Microscope, the simple, 361 ; magnifying power of, 362 ; the compound, 362.
- Minimum thermometers, 227.
- Mirrors, plane, 302 ; curved, 309 ; centre of curvature of, 309 ; radius of curvature of, 309 ; aperture of, 309 ; axis of, 309 ; focus of, 310 ; parabolic, 317 ; conjugate foci of, 313.
- Molecules, description of, 131 ; evidence suggesting, 131 ; motions of, 134 ; velocities of, 136 ; motions in liquids, 138 ; motions in solids, 139 ; size of, 146 ; nature of, 148.
- Moment of a force, 44.
- Moments, law of, 45.
- Momentum, definition of, 34.
- Motion, 18 ; under gravity, 22 ; in a circle, 28 ; translation and rotation, 28 ; Newton's first law of, 35 ; Newton's second law of, 36 ; Newton's third law of, 42.
- Multiple arrangement of cells or dynamos, 475.
- Musical sounds and noises, 179
- N**
- Nodes, 166 ; in a vibrating string, 189.
- Non-conductors, electrical, 381.
- O**
- Oboe, 211.
- Octave, the, 182.
- Oersted's experiment, 403.
- Ohm, the international, 462.
- Ohm's law, 462.
- Opaque bodies, 292.
- Optical bench, 336
- Organ pipes, 196.
- Osmosis, 139.
- Overtones, in a string, 190 ; in an organ pipe, 197.
- P**
- Parabolic mirrors, 317.
- Pascal's principle, 83.
- Permeability, magnetic, 373.
- Phonograph, 213.
- Photometer, Rumford's, 295 ; the Bunsen, 296 ; Joly's diffusion, 297.
- Piccolo, 210.
- Pipe organ, 210.
- Pitch, 180 ; determination of, 180.
- Plasticity, 145.

Point, position of, a, 17.
 Polarization, of a cell, 404 ; of electrodes, 414.
 Poles of a magnet, 367.
 Polonium, radio-activity of, 490
 Position, of a point, 17.
 Potential, electrical, 388 ; zero of, 389 ; fall of, in a circuit, 464.
 Pound, standard, 8.
 Poundal, the, 40.
 Power, definition of, 59 ; units of, 59.
 Pressure, transmission of, by fluids, 82 ; due to weight, 86, 88 ; relation between pressure and depth, 87 ; equal in all directions at the same depth, 87.
 Primary currents, 437.
 Pulley, the, 71 ; a single movable, 72 ; differential, 76.
 Pulleys, systems of, 72.
 Pumps, lift-pump, 126 ; force-pump, 127 ; double action force-pump, 128.

Q

Quality of sound, 200.
 Quantities, physical, 1.
 Quantity, measuring a, 2.
 Quantity of electricity, unit of, 465.

R

Radiant energy, forms of, 216, 287, 479.
 Radiation, transference of, by heat, 285 ; of light, 287, 480.
 Radio-activity, 490.
 Radium, radio-activity of, 490.
 Radius of curvature of mirror, 309.

Rain, 264.
 Rainbow, 348.
 Recomposition of white light, 343.
 Reflection of light, laws of, 302 ; regular and irregular, 305 ; from parallel mirrors, 307 ; from inclined mirrors, 307 ; total, 325.
 Reflection of sound, 175.
 Refraction of light, meaning of, 319 ; experiments illustrating, 319 ; explanation of, by means of waves, 320 ; laws of, 322 ; table of indices of, 323 ; through a plate, 324 ; atmospheric, 327 ; through prisms, 328.
 Regelation, 245.
 Resistance, determination of, 468 ; laws of, 470 ; specific, 470 ; and temperature, 471 ; in a divided circuit, 472.
 Resistance boxes, 468.
 Resistances, table of, 471.
 Resonance, 193 ; of an open tube, 195.
 Resonators, forms of, 194.
 Röntgen rays, 487 ; photographs with, 488 ; properties of, 488.

S

Saxaphone, 211.
 Scale, diatonic, 183 ; of equal temperament, 184 ; the harmonic, 185.
 Screw, the, 78.
 Secondary currents, 437.
 Self-induction, 439.
 Series arrangement of cells or dynamos, 475.
 Shadows, theory of, 291.

- Shunts, 473.
 Siphon, 129 ; the aspirating, 129.
 Snow, 264.
 Solidification, 243.
 Solids, distinction between liquids and solids, 141.
 Sonometer, the, 187.
 Sound, origin of, 168 ; conveyance of, 168 ; velocity of, in air, 169 ; intensity of, 172 ; transmission of, by tubes, 173 ; velocity of, in solids, 173 ; velocity in different gases, 175 ; reflection of, 175 ; determination of velocity of, by resonance, 194 ; quality of, 200.
 Sound-waves, nature of, 170 ; interference of, 205.
 Specific heat, 239 ; of water, 240 ; determination of, by method of mixtures, 240.
 Specific heats of some common substances, 241.
 Specific resistance, 470.
 Spectra, kinds of, 350 ; continuous, 351 ; discontinuous, 351 ; absorption, 351.
 Spectroscope, 348.
 Spectrum, 339 ; a pure, 340 ; analysis of, 351 ; the solar, 352 ; meaning of dark lines of, 352.
 Standards, of length, 2 ; national, 5 ; of mass, 7 ; of light, 298.
 Steam-engine, 268 ; high and low pressure, 269 ; the compound, 269 ; the turbine, 269.
 Steam heating, 283.
 Storage cells, 415.
 Strain, 143 ; Shearing, 145
 Stresses, 143.
 Stringed instruments, 209.
 Sublimation, 140.
 Submarine bell, 177.
 Surface tension, 151 ; illustrations of, 155.
 Sympathetic electrical oscillations, 483.
 Sympathetic vibrations, 202 ; illustrations of, 203.
- T**
- Tangent galvanometer, 431.
 Telegraph, the electric, 427 ; key, 427 ; sounder, 428 ; relay, 428 ; wireless, 485.
 Telegraph system, connection of instruments in, 429.
 Telephone, 455 ; transmitter, 455 ; receiver, 455.
 Telephone circuit, connection of instruments in, 456.
 Telescope, the astronomical, 363 ; objectives and eyepieces, 365 ; the terrestrial, 366.
 Temperature, nature of, 222 ; and quantity of heat, 222 ; determination of, 222 ; absolute, 234 ; critical, 259.
 Thermal capacity, 239.
 Thermometer, Galileo's, 223 ; construction of a mercury, 224 ; determination of the fixed points of, 225 ; graduation of, 225 ; comparison of scales of, 226 ; gas, 234.
 Thermometers, maximum and minimum, 227.
 Thermostats, 220.
 Time, unit of, 9.
 Tones, musical, 180 ; simultaneous production of, 190 ; fundamental, 186 ; fundamental in a string, 188.

Toricellian experiment, 102.
 Total reflection, of light, 325 ;
 prisms, 326.
 Transference of heat, by conduction,
 274 ; by convection, 279 ; by
 radiation, 285.
 Transformer, the, 451.
 Translucent bodies, 292.
 Transparent bodies, 292.
 Trombone, 212.
 Tuning-fork, 191.
 Turbine engine, 269.

U

Units, fundamental, 2 ; derived, 7 ;
 of time, 9 ; the English and the
 C.G.S. system, 10 ; of force, 37 ;
 of work, 54 ; of power, 59 ; of
 heat, 238 ; of electromotive force,
 401, 463 ; of resistance, 462 ; of
 current strength, 463 ; of quantity
 of electricity, 465.
 Uranium, radio-activity of, 490.

V

Vaporization, 248.
 Vapour, pressure of, 249 ; satu-
 rated, 250.
 Velocities, composition of, 29 ; reso-
 lution of, 30 ; triangle and
 polygon of, 31.
 Velocity, definition of, 18 ; uniform,
 19 ; average, 21 ; of sound in air,
 169 ; of sound in solids, 173 ; of
 sound in gases, 175 ; determina-
 tions of, of light, 300, 301 ; illus-
 trations of, of light, 301 ; of light
 in liquids and solids, 301.

Ventilation, 284.
 Vertex of a mirror, 309.
 Vibrating flames, 200.
 Vibration number, 164.
 Vibrations, period of, 164 ; fre-
 quency of, 164 ; laws of, of a
 string, 188 ; of rods, 190 ; of
 plates, 192 ; of air columns, 193 ;
 mode of, in an open tube, 196 ;
 sympathetic, 202.
 Viscosity, 140.
 Volt, the international, 463.
 Voltaic cell, 396 ; plates of a, elec-
 trically charged, 398 ; chemical
 action in, 400 ; source of energy
 in, 401 ; electromotive force of,
 402 ; polarization of, 404 ; theory
 of the action of, 409 ; grouping
 of, 475.
 Voltameters, 417.
 Voltmeters, 432.

W

Watt, the, 59, 466.
 Watt-hour, the, 467.
 Wave-length, definition of, 160 ;
 relation among wave-length, velo-
 city, and frequency, 164.
 Wave-motion, characteristics of,
 157.
 Waves, cause of, on water, 158 ;
 speed of, on water, 160 ; speed
 dependent on depth, 161 ; refra-
 ction of, 162 ; reflection of, 162 ;
 transverse and longitudinal, 164 ;
 in a cord, 163 ; method of study-
 ing standing, 167.
 Weather, elementary principles of
 forecasting, 110.
 Weather map, 107.

- Wedge, the, 78.
Weight, definition of, 12 ; measurement of, 51.
Weights, 12 ; metric, 13.
Wheatstone bridge, 469.
Wheel and axle, the, 74 ; examples of, 75 ; differential, 75.
Wimshurst, influence machine, 393 ; explanation of action of, 394.
Winds, 280.
- Wireless telegraphy, 485.
Work, definition of, 54 ; units of, 54 ; measurement of, 55.
- X**
- X-rays, 487.
- Y**
- Yard, standard, 2.

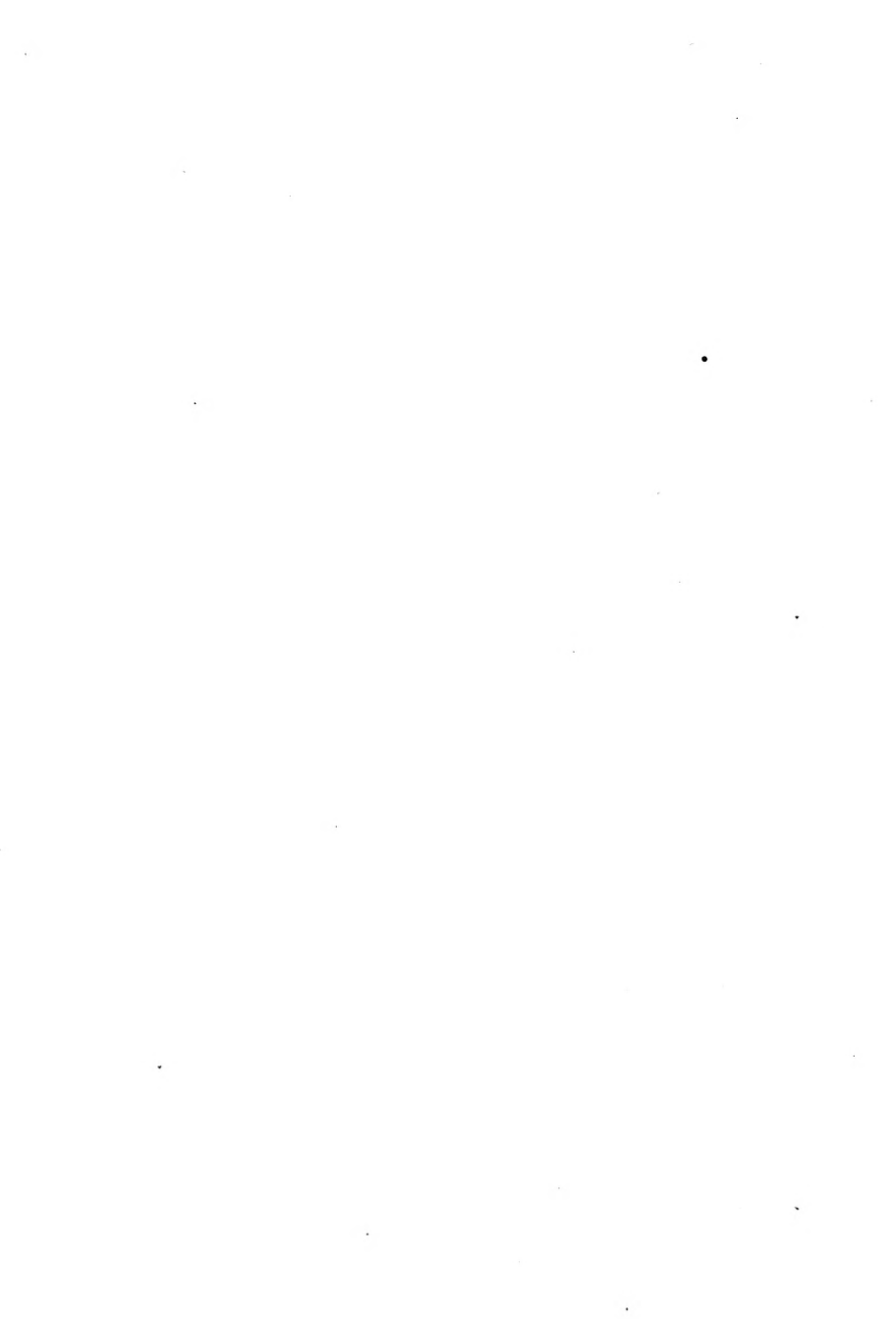

LT1001.307. M475 1917

