

COLUMBIA LIBRARIES OFFSITE
HEALTH SCIENCES STANDARD



HX64076288

RA967 At5

The orientation of b

RECAP

RA967 A, t5

Columbia University
in the City of New York

College of Physicians and Surgeons



Library

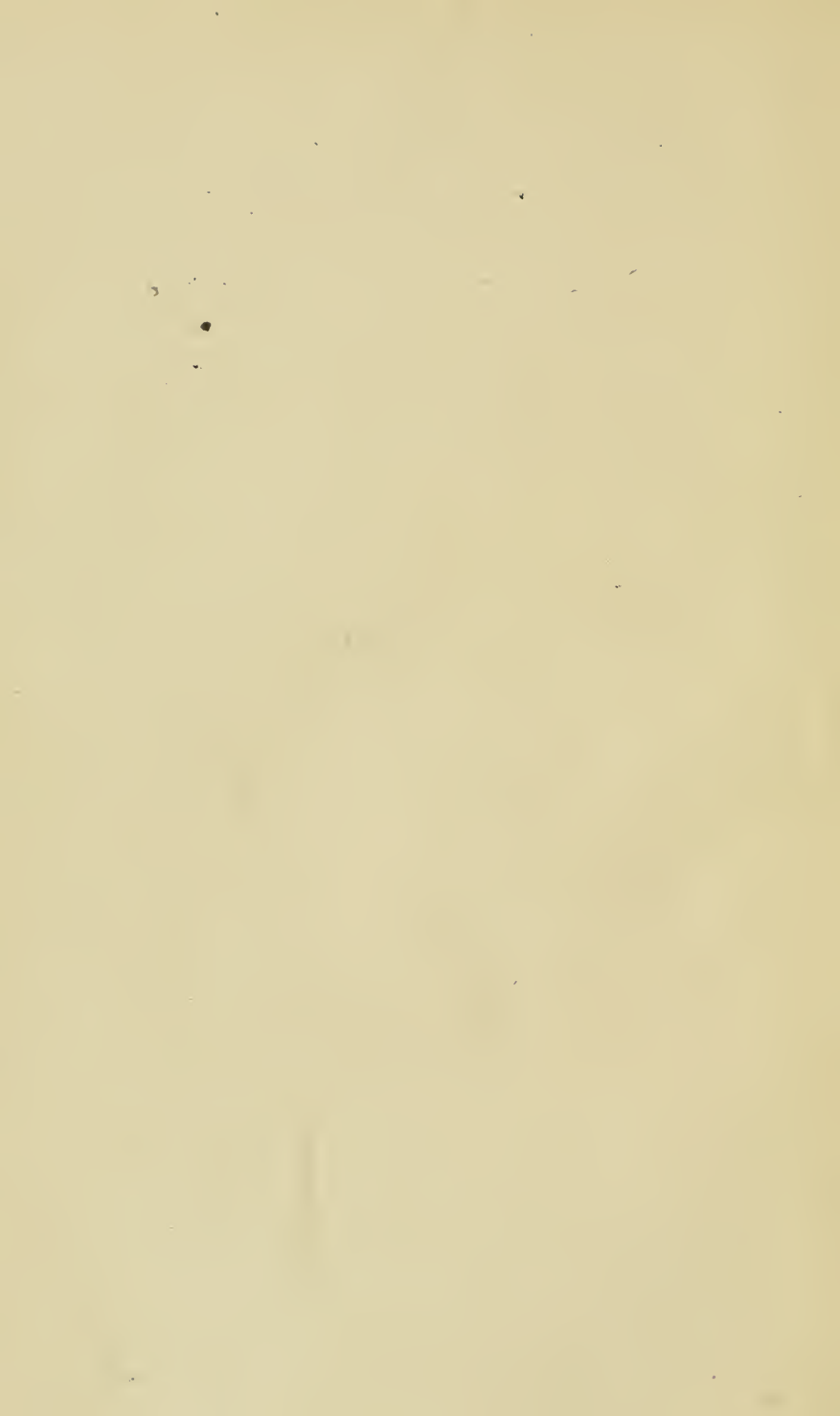

The
Orientation of Buildings
or
Planning for Sunlight

by
William Atkinson
Fellow of the Boston Society of Architects

FIRST EDITION
First Thousand

NEW YORK
JOHN WILEY & SONS
London: CHAPMAN & HALL, Limited
1912

RA967

A+5

COPYRIGHT, 1912,
BY
WILLIAM ATKINSON

Entered at Stationers' Hall, London

Stanbope Press
F. H. GILSON COMPANY
BOSTON, U.S.A.

IN MEMORY OF
J. TRUMAN BURDICK

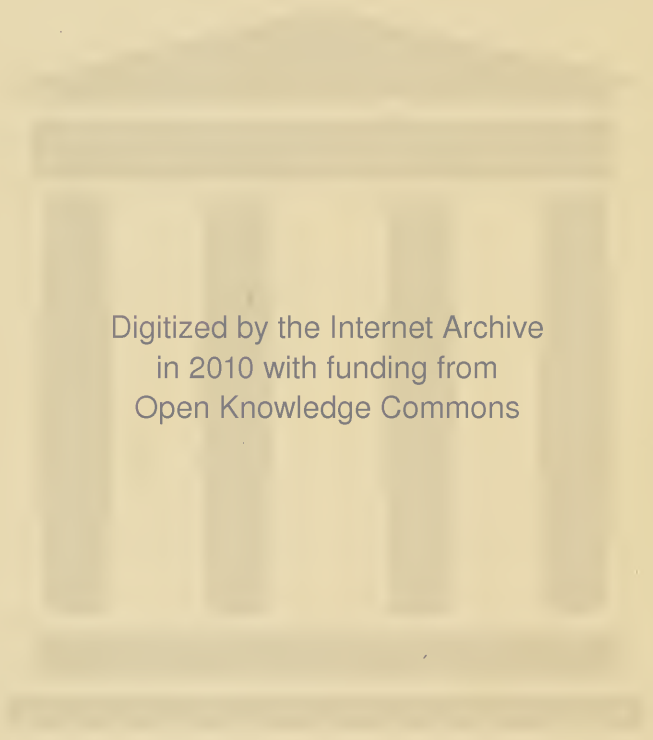

Digitized by the Internet Archive
in 2010 with funding from
Open Knowledge Commons

PREFACE

THE purpose of this book is to set forth the principles which ought to govern the planning of buildings with respect to sunlight, a subject to which very little attention has been given.

Several years ago, in an essay on hospital construction,¹ I wrote as follows: "To study properly the question of sunlight, a sun plan of the buildings must be drawn, and their positions considered with respect to the shadows they cast upon each other and upon the ground." This statement describes very well the general method of study which I have followed in my investigations, the results of which are now for the first time presented to the public in a complete form.

I had begun my study of orientation with hospitals especially in mind, but I soon realized that the general principle of planning with reference to sunlight was of fundamental importance in the design of all buildings, and especially in the planning and laying out of cities. In this connection I may mention that a series of diagrams made by me, at the request of a committee interested in securing new legislation regulating the height of buildings in Boston in 1904, was of great service in showing the effect of tall buildings

¹ "Small Hospitals," by A. Worcester, M. D., and "Suggestions for Hospital Architecture," by William Atkinson, Architect, New York, John Wiley & Sons, 1894.

in overshadowing and shutting out the sunlight from the streets. Another series of street diagrams, first shown at a lecture given by me before the Society of Arts, at the Massachusetts Institute of Technology, has been reprinted by permission in a recent English book on city planning. Some of my earlier studies in orientation, originally published in the *National Hospital Record*, have been twice reprinted in *The Brickbuilder* magazine, and also embodied, by permission, in a recent American book on hospital construction.

All of which has encouraged me to believe that a more complete presentation of the subject, in book form, would not be without interest to the public.

In my first chapter I have included so much of the elements of astronomy as is necessary to a clear understanding of the apparent motion of the sun, and the variations in the angles of sunlight at the different seasons. I have also described the method of the stereographic projection, by which the angles of sunlight may easily be obtained, for any season of the year, and for any latitude.

The second chapter deals with the distribution of sunlight upon the exterior of buildings, and its admission to the interior, through windows.

In this chapter I have developed the method of the "shadow curve" and the "area of complete shadow," an application of the principles of descriptive geometry to the recording of transitory occurrences, which, as far as I am aware, is new. General principles for the planning and placing of buildings are given as far as it has seemed desirable. It is, however, to be understood that, for the

best results, each case must be studied as a separate problem, with reference to local conditions, and especially with reference to the latitude of the place. In connection with the study of windows an account is given of my experiments with the "sun box," an apparatus devised by me to test the practical effect of different window exposures.

My third chapter is devoted to hospitals. In it I have discussed the vexed question of the best orientation for hospital ward pavilions and have ventured to make recommendations in this regard at variance with common practice. I have also presented a plan for a new type of hospital building especially designed to meet the needs of modern medical treatment.

The last chapter is concerned with the distribution of sunlight in streets, as affected by their direction and width, and the height of the buildings upon them. In an appendix I have given in full the building law of Paris regulating the height of buildings and a synopsis of the regulations of some American cities in this matter.

While the working out of the diagrams and the calculation of the tables has been a matter of pure mathematics, admitting but one result, the conclusions to be drawn from them are to some extent a matter for individual judgment.

It is therefore fitting that I should give here a statement of the premises on which my recommendations are based.

I have assumed that it is desirable, in our climate, that all buildings in which human beings dwell or work should have all of their exterior walls exposed to direct sunlight at some time during the day throughout the year, and that the surfaces of streets, alleys, areas, courtyards, and other

spaces in and around buildings should also be exposed as much as possible to the action of direct sunlight.

In regard to windows, I have assumed that as much direct sunlight as possible is desirable through them during that period of the year in which they are customarily kept closed. On the other hand, during the hot season, when windows may be open day and night, and the sun-purified air brought in from outside by natural means, I have assumed that direct sunlight through windows is rather to be avoided than sought after.

The function of sunlight in promoting healthy conditions, and its use as a therapeutic agent, may only be authoritatively stated by sanitarians and medical men who have given special study to this question, and I can do no more than refer those who may wish to pursue this branch of the subject to the work of the German and Danish investigators, a full account of which may be found in *Luft-und Sonnenbäder*, by Dr. Julian Marcuse, Stuttgart, 1907.

The diagrams for this book have been engraved by the wax process from drawings made by me, and the few which have appeared in former published articles have been carefully revised and redrawn.

BOXFORD, MASS.,
October, 1911.

CONTENTS

CHAPTER I

THE ASTRONOMICAL DATA

Sunlight a requisite for healthy buildings. — An elementary knowledge of astronomy necessary for intelligent sun-planning. — The angles of sunlight at the different seasons and in different latitudes. — Calculation of the angles of sunlight by the stereographic projection. — By spherical trigonometry. — Table of sunlight angles.

CHAPTER II

SHADOW DIAGRAMS

Shadows of the cube. — Orientation of the Swiss house. — Shadow curves of the cube. — Theory of the area of complete shadow. — The area of complete shadow as applied to the study of fundamental types of building plan. — Sunlight admitted by windows. — The visual angle of windows. — Quantity of sunlight admitted by windows. — Heating effect of sunlight. — The solar constant. — The sun box. — Sun-box records.

CHAPTER III

HOSPITALS

The orientation of ward pavilions. — Different views upon the subject. — Recommendations of the author. — The typical ward pavilion. — Its unsuitability to modern conditions. — A new type of ward needed. — Description of the pyramidal type of ward.

CHAPTER IV

STREETS

Angles of sunlight in streets. — Sunlight curves in streets. — The orientation of streets. — Horace Bushnell's theory. — The height of buildings. — European building regulations. — The law of ancient lights. — Building law recommended by the author. — The skyscraper and the street.

APPENDIX A

Sun tables for London and New Orleans.

APPENDIX B

Building laws of Paris regulating the height of buildings.

APPENDIX C

Building laws of American cities regulating the height of buildings.

LIST OF ILLUSTRATIONS

CHAPTER I

FIG.	PAGE
1. Cross sections of the visible celestial sphere	3
2. Apparent orbits of the sun at the different seasons	6
3. Paths of the sun at intermediate periods	7
4. Stereographic projection of the visible celestial sphere	9
5. Construction of the stereographic projection. — First step	12
6. Construction of the stereographic projection. — Second step	14
7. Construction of the stereographic projection. — Third step	16

CHAPTER II

8. Shadows of the cube	20
9. Shadows of the cube	21
10. Shadows of the cube	22
11. Plan of typical Swiss dwelling	23
12. Shadow curves of the cube. Winter solstice	25
13. Shadow curves of the cube. Winter solstice	26
14. Shadow curves of the cube. Equinoxes	27
15. Shadow curves of the cube. Equinoxes	28
16. Shadow curves of the cube. Summer solstice	29
17. Shadow curves of the cube. Summer solstice	30
18. Areas of complete shadow: single straight block	32
19. Areas of complete shadow: L plan	33
20. Areas of complete shadow: U plan	34
21. Method of obtaining the <i>area of complete shadow</i>	36
22. Shadow curves of cube and prism at winter solstice	37
23. Maximum <i>areas of complete shadow</i> for the L and U plans	38
24. Effect of increase of height upon the <i>area of complete shadow</i>	39
25. Good and bad arrangement of L	41
26. Application of the test of the <i>area of complete shadow</i>	42
27. Shadows of the single straight block. Axis N. and S.	44

FIG.	PAGE
28. Shadows of the single straight block. Axis E. and W.....	45
29. Shadows of the single straight block. Axis N. E. and S. W.	46
30. Visual angle of ordinary window.....	47
31. Visual angle of mediæval window.....	48
32. Wall section with beveled piers.....	49
33. Window illumination: winter solstice.....	50
34. Window illumination: equinoxes.....	51
35. Window illumination: summer solstice.....	52
36. Cross sections of sunlight prism.....	53
37. Change in area of sunlight prism: winter solstice.....	55
38. Change in area of sunlight prism: equinoxes.....	56
39. Change in area of sunlight prism: summer solstice.....	57
40. Windows: obstructed outlook.....	59
41. Obstructed outlook: stereographic projection.....	61
42. Change in area of sunlight prism: obstructed outlook.....	62
43. Cross section of sun box.....	64
44. Photograph of sun box.....	65
45. Sun box records.....	76
46. Sun house.....	77

CHAPTER III

47. Ward pavilion: open-ended type.....	80
48. French method of hanging outside blinds.....	84
49. Economy of two-story type of pavilion.....	86
50. Section of ward with ridge ventilation.....	88
51. Types of ward pavilions.....	89
52. Grouping of ward units: Virchow Hospital.....	91
53. Grouping of ward units.....	92
54. Grouping of ward units.....	93
55. Grouping of ward units.....	95
56. Elevation of Virchow ward unit.....	97
57. Pyramidal type of ward construction.....	98
58. Pyramidal ward unit: first-floor plan.....	99
59. Pyramidal ward unit: second-floor plan.....	100
60. Pyramidal ward unit: third-floor plan.....	101
61. Pyramidal ward unit: shadow diagram.....	102

FIG.	PAGE
62. Pyramidal ward unit: shadow diagram.....	103
63. Pyramidal ward unit: shadow diagram.....	104
64. Pyramidal ward unit: general plan.....	106
65. Pyramidal ward unit: elevation.....	107

CHAPTER IV

66. Angles of sunlight in streets.....	111
67. Angles of sunlight in streets.....	112
68. Angles of sunlight in streets.....	113
69. Method of obtaining sunlight curves.....	114
70. Sunlight curves: streets.....	116
71. Building law of Paris.....	119
72. Typical cornice section.....	122
73. Proposed building law.....	123
74. The skyscraper and the street.....	124

THE ORIENTATION OF BUILDINGS

CHAPTER I

THE ASTRONOMICAL DATA

UNQUESTIONABLY one of the first requisites for a healthy building is abundance of sunlight. Not only the exterior wall surfaces of buildings, but also the surfaces of the ground around them, should have the direct rays of the sun for as long a time as possible each day.

“Second only to air, is light and sunshine essential for growth and health; and it is one of Nature’s most powerful assistants in enabling the body to throw off those conditions which we call disease. Not only daylight, but sunlight; indeed, fresh air must be sun-warmed, sun-penetrated air. The sunshine of a December day has been recently shown to kill the spores of the anthrax bacillus.” (Healthy Hospitals, Sir Douglas Galton, Oxford, 1893).

To secure sunlight in fullest measure requires careful and intelligent planning with this end in view. It is necessary for such a study to have at hand a table, giving the angles of sunlight at the different hours of the day and at the different seasons of the year, for the particular latitude in question.

In this chapter I shall describe one method by which such a table may be prepared.

In all of the operations of practical astronomy, as in the calculation of position of ships at sea, or in determinations of latitude and longitude upon land, it has been found best to go back to the conceptions of the first astronomers, who imagined the earth to be the center of the universe, and the celestial bodies to revolve around it.

And thus has survived the ancient fiction of the "celestial sphere."

Viewing the heavens on a starry night, the whole firmament seems slowly to revolve, successively bringing into view, above the eastern horizon, one constellation after another.

If, by magic power, the sun's light could be dimmed so that the stars should be visible in the daytime, he would appear, like them, to be fixed in the celestial sphere, and to turn with the constellations in their uniform diurnal motion around the pole.

But if we could extend our observations over a period of several weeks, we should observe that the sun was slowly changing his position among the stars, passing in the course of a single year through the successive constellations of the zodiac, in summer north of the celestial equator, in winter south.

But this change in the apparent position of the sun is so slow that for any single day it may be disregarded, and his position for that day considered as fixed in the celestial sphere.

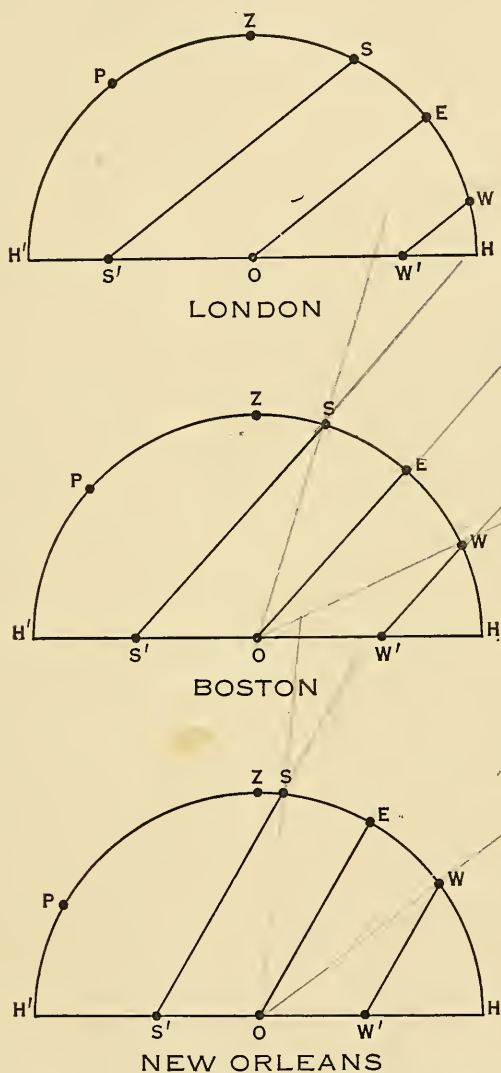

FIG. 1. — Cross sections of the visible celestial sphere, showing the path of the sun at the solstices, and at the equinoctial periods, for different latitudes.

Fig. 1 shows in cross section that part of the celestial sphere which is above the horizon, at the latitudes respectively of London (Lat. $51^{\circ}-30'$ N.), Boston (Lat. $42^{\circ}-22'$ N.), and New Orleans (Lat. $30^{\circ}-0'$ N.).

In these diagrams $H'H$ represents the plane of the horizon; O the position of the observer; P the celestial north pole; Z the zenith; and SS' , EO , and WW' the apparent paths of the sun at the periods of the summer solstice, the equinoxes, and the winter solstice, respectively.

It is evident that the altitude of the sun, at noon, at the periods of the year referred to, may be obtained directly from the diagrams, being given by the angles HOS , HOE , and HOW , for the summer solstice, the equinoxes, and the winter solstice, respectively.

It will be observed that these angles are less in the more northerly latitudes, and that the path of the sun inclines more and more toward the horizon.

This decrease in the altitude of the sun is accompanied with an increasing divergence between the extreme points of sunrise and sunset, so that the days in summer are much longer, and in winter much shorter, in the countries of the far north, than in those which are near the equator.

At latitude $42^{\circ}-0'$ N. (approximately the latitude of Boston, Mass.) the sun rises on the longest day of the year about $32\frac{1}{2}^{\circ}$ north of east and sets at an equal angle north of west, reaching at noon an altitude of $71^{\circ}-27'$ above the horizon.

On the shortest day of the year he rises about $32\frac{1}{2}^{\circ}$ south of east and sets at an equal angle south of west, reaching at noon an altitude of only $24^{\circ}-33'$ above the horizon.

At the two periods of the year when day and night are of equal length he rises in the east and sets in the west, reaching at noon an altitude of $48^{\circ}-0'$ above the horizon.

The perspective diagrams of Fig. 2 will give the student an easily-remembered mental image of the path of the sun at these periods.

The horizontal circle represents the horizon; the inclined circle the path of the sun, and the diverging lines the direction of the sun's rays at the different hours of the day.

It will be noted that at the period of the equinoxes the trace of the sun's rays describes a plane; at the period of the summer solstice a hollow cone, and at the period of the winter solstice a convex cone.

His path at intermediate periods may be pictured by the aid of the following diagram (Fig. 3) which gives his position at intervals of one month apart throughout the year.

It will be observed from this diagram that the path of the sun during the four months from April 21 to August 21 resembles more nearly his path at the summer solstice than his path at the equinoxes, and similarly his path during the four months from October 21 to February 21 more nearly his path at the winter solstice than his path at the equinoxes.

This must be borne in mind in studying the various shadow diagrams which are given later in this book. Those which are drawn for the period of the winter solstice may be taken as typical of the four months from October 21 to February 21; those which are drawn from the period of the summer solstice of the four months from April 21 to

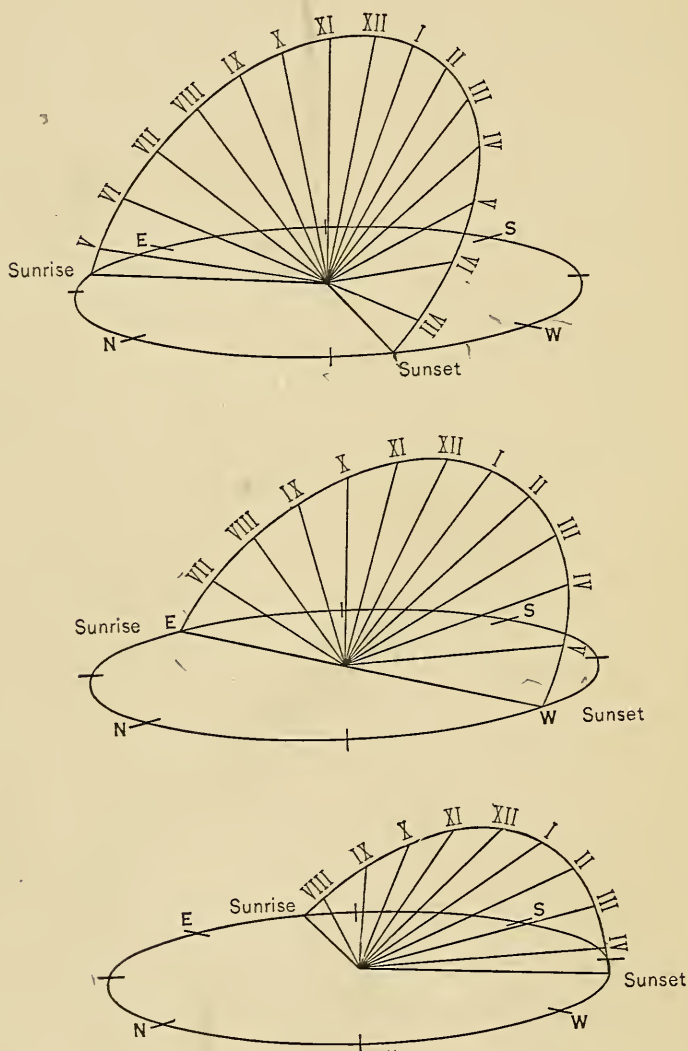

FIG. 2. — Perspective diagrams showing the apparent path of the sun, and the angles of sunlight at the different hours of the day, for Lat. $42^{\circ}-0' N$. The upper diagram is drawn for the summer solstice, the middle diagram for the vernal and autumnal equinox, and the lower diagram for the winter solstice.

August 21; and those which are drawn for the period of the equinoxes of the two months from February 21 to April 21, and the two months from August 21 to October 21.

The position of the sun with respect to the observer is generally expressed in terms of azimuth and altitude.

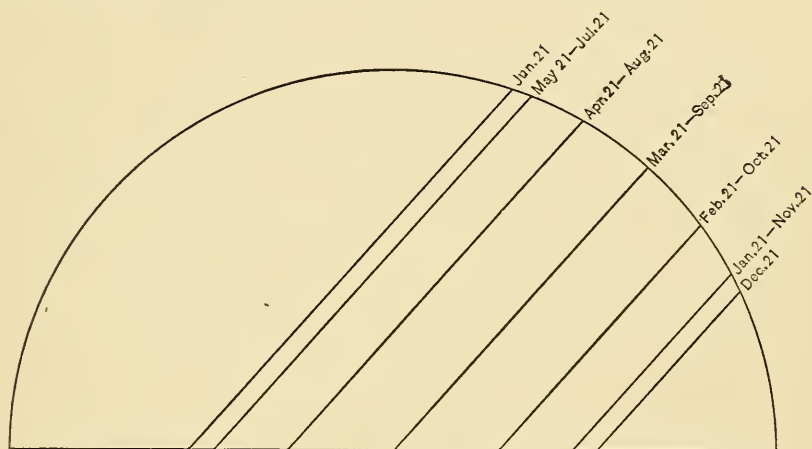

FIG. 3. — Cross-section of the visible celestial sphere showing the path of the sun at periods one month apart throughout the year. Lat. $42^{\circ}-0'$ N. Actually the declination of the sun on May 21 does not exactly coincide with his declination on July 21, although it is so represented in the diagram. A similar observation applies to the other dates which are grouped in pairs. The differences, however, are so slight that it would be difficult to represent them at the scale at which the drawing is made.

The latter term requires no explanation, but the meaning of "azimuth" may not be so generally understood. It may preferably be explained by an example rather than a definition.

Imagine a stick set upright in level ground in the sunlight. The deviation of the shadow cast by the stick

from a true north and south direction is the azimuth of the sun at that moment.

Knowing the distance of the sun north or south from the equator (which information may be obtained from the almanac³) the azimuth and altitude for any particular day may be calculated by spherical trigonometry.

The desired data may also be obtained very simply and easily, and with sufficient accuracy for our purposes, by the stereographic projection.

To one who understands perspective, the stereographic projection presents little difficulty, as it is virtually the method of linear perspective applied to the representation of the sphere, but with this difference, that the drawing when completed is viewed from behind the picture plane, instead of in front of it, as in ordinary perspective.

It possesses two properties which make it especially useful; the first being that all circles of the sphere are projected as circles or as straight lines, and hence may be drawn with compasses and ruler; and the second being that the angle made by the crossing of two circles upon the surface of the sphere is the same as the angle made by their projections.

The statement that by the aid of the stereographic projection one may, with a few hours' labor, construct a diagram which will give the position of the sun at each hour of the day for any period of the year desired, and for any latitude, should be sufficient to induce the student to master its principles.

Such a diagram, drawn for latitude $42^{\circ}-0'$ N., is shown in Fig. 4.

This is a stereographic projection of the celestial sphere, taken upon the plane of the horizon, which is represented by the circle *N, E, S, W*, these letters being placed at the four cardinal points.

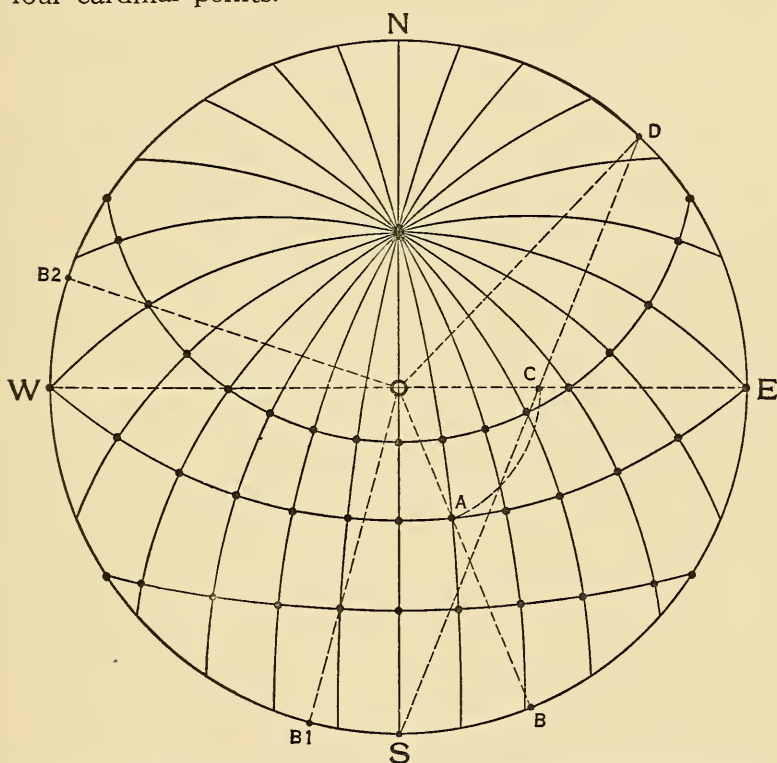

FIG. 4. — Stereographic projection of the visible celestial sphere, upon the plane of the horizon.

The circular arc *WE* is the projection of the celestial equator, which is the path of the sun at the period of the equinoxes.

The arc of considerably greater curvature to the north is the projection of the tropic of Cancer, which is the path

of the sun at the summer solstice, while the more flattened and shorter arc to the south is the projection of the tropic of Capricorn, which is the path of the sun at the winter solstice.

The twelve circles converging toward the upper part of the diagram are the projections of the celestial meridians, or *hour circles*, 15° apart.

These hour circles may be conceived of as a gigantic cage or framework, fixed in position, and serving as a system of celestial verniers, to mark the passage of the heavenly bodies, which are carried past them with the revolution of the sphere.

The passage of the sun across the successive hour circles marks the hours of the day as shown by a sundial. Consequently the intersection of any hour circle with the circle representing the path of the sun is the stereographic projection of the sun's position for the corresponding hour and period of the year.

And from this projection the azimuth and altitude may readily be found.

For instance, the dotted line OB drawn through the intersection of the 11-o'clock hour circle and the celestial equator gives the azimuth of the sun at 11 A.M. (*solar time*) at the period of the equinoxes, and the dotted line OB_1 drawn through the intersection of the 1-o'clock hour circle and the tropic of Capricorn gives the azimuth of the sun at 1 P.M. on December 21st, and the dotted line OB_2 drawn through the intersection of the 6-o'clock hour circle and the tropic of Cancer gives the azimuth of the sun at 6 P.M. on June 21st.

The altitude is obtained by a simple construction. For example, the angle EOD is the altitude of the sun at 11 A.M. at the period of the equinoxes and is found by measuring off on the line OE the distance OC equal to OA and drawing the line SC intersecting the enclosing circle at the point D .

To explain more fully the construction of the diagram, an example will be given and worked out.

Let it be required to find the position of the sun at 10 A.M., *solar time*, April 16, Lat. $30^{\circ}-0'$ N.

Draw a cross section of the visible celestial sphere, as shown in the upper part of Fig. 5.

HH is the horizon, O the position of the observer, and Z the zenith. Through O draw the line POP' making an angle of $30^{\circ}-0'$ with the horizon.

P is the celestial north pole, for it is shown in astronomy that the altitude of the pole is equal to the latitude of the place.

Draw OE at right angles to POP' .

It represents the celestial equator.

From the point E lay off the arc ES equal to the declination of the sun on the date required. This we find from the almanac (for 1910) to be $9^{\circ}-59'$ for April 16.

Draw SM parallel to OE . It represents the path of the sun above the horizon at this period.

The projection is made upon the plane of the horizon, and the station point is upon the surface of the sphere vertically below the zenith, at N .

Any point upon the surface of the sphere is projected

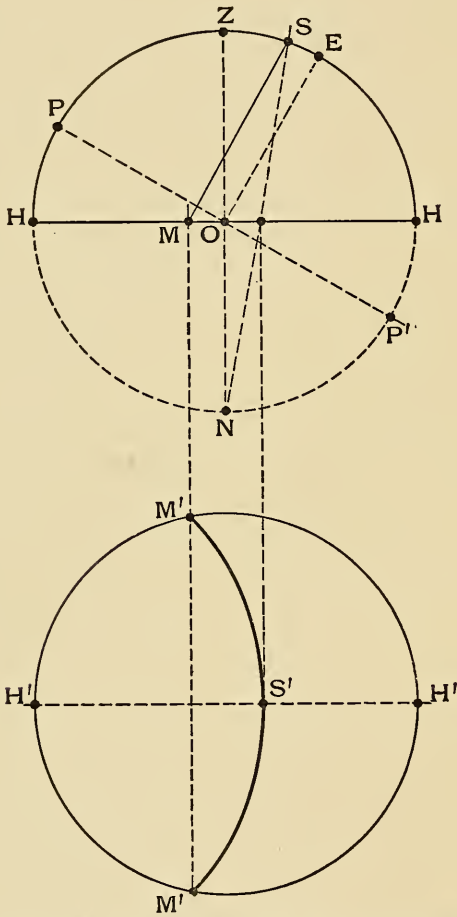

FIG. 5. — Construction of the stereographic projection, first step. The upper part of the diagram is a cross section of the celestial sphere; the lower part its projection upon the plane of the horizon.

by joining it to the station point by a straight line and the point in which this line pierces the picture plane HH is the projection required.

The enclosing circle is the horizon, which is drawn without change since it lies in the plane of the projection.

The circle MS may now be projected.

It is evident that M' and M' are the points at which this circle cuts the horizon, and that S' is the projection of the point S .

Through these three points draw the arc of a circle.

It is the projection required, for it is a theorem of the stereographic projection that all circles of the sphere are projected as circles or portions of circles, with the exception of those which pass through the station point, which are obviously projected as straight lines.

An example of the latter is the meridian or 12-o'clock hour circle, which is projected as the straight line $H'S'H'$.

To find the point upon the arc $M'S'M'$ where the sun is at 10 A.M. it is necessary to project the 10-o'clock hour circle.

(For the sake of clearness the operation is shown in a separate diagram, Fig. 6.)

Since all the hour circles pass through the north and south poles, we have at once, in the projections of the poles (at PP and $P'P'$), two points of our required projection.

It remains to find the center.

The line LT , equidistant from PP and $P'P'$, contains the centers of all circles passing through those points.

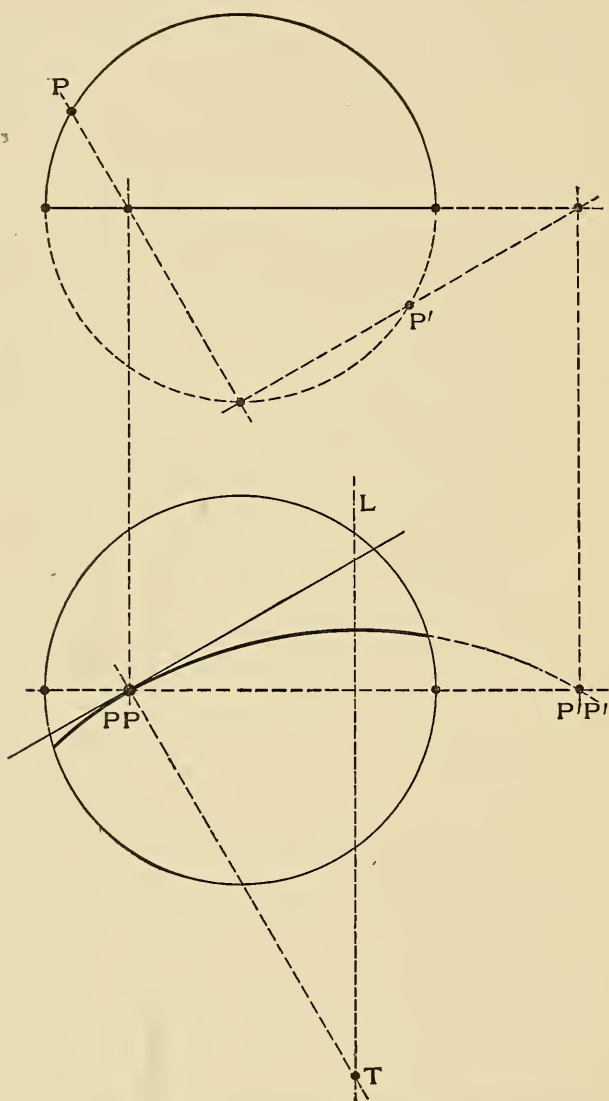

FIG. 6. — Construction of the stereographic projection, second step.

To find the point upon this line which is the center of the projected 10-o'clock hour circle, we avail ourselves of the second theorem of the stereographic projection, which is that the angle made by two circles upon the surface of the sphere is the same as the angle made by their projections.

Now the 10-o'clock hour circle makes an angle of 30° with the noon circle, or meridian, where it crosses the latter at the poles, one hour being equal to 15° .

Consequently a line drawn through PP , the projection of the north pole, and making an angle of 30° with $PP'P'$, the projection of the meridian, is a tangent to the projection of the 10-o'clock hour circle, and establishes the center of the latter at once, at the point T , upon the line LT .

The circle may now be drawn.

Superposing the two circles thus obtained in one diagram (Fig. 7), their intersection at A is the projection of the sun's position and the angle $H'OX$ is the true bearing or azimuth of the sun required.

The altitude may be found by a secondary construction. (Lower diagram of Fig. 7.)

It is evident that the straight line XAO is the projection of a circle, vertical to the plane of the horizon, and passing through the zenith and the sun.

The sun's altitude is measured upon this circle, upward from the horizon.

Let us imagine this circle to be revolved into the plane of the horizon, thus bringing the station point to the position N and the zenith to the position Z .

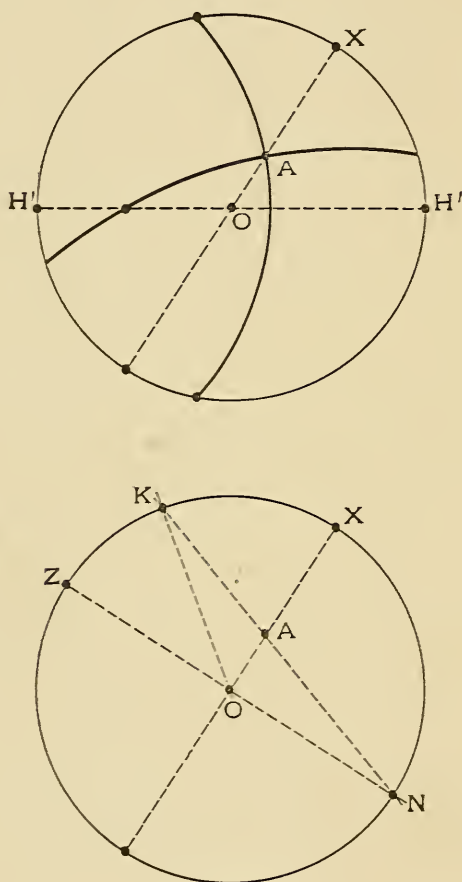

FIG. 7. — Construction of the stereographic projection, third step. (The point P referred to in the text is the projection of the north pole, to the left of O , on the dotted line $H'H'$.)

The sun lies at some point upon this circle. To find this point draw the line *NA* cutting the circle at *K*. It is the point required, and *XOK* is the altitude of the sun required.

By following the above method and making the projection at a large scale the angles may be found with sufficient accuracy for the purposes of the architect.

To obtain the result by calculation involves the solution of the spherical triangle *POA* of which the two sides *PA* (the north polar distance of the sun), *PO* (the co-latitude of the place), and *APO* (the assumed hour angle) are known. (Upper diagram of Fig. 7.)

Solving for the angle *AOP* and the third side *AO* gives us *H'OX*, and *XA* the azimuth and altitude respectively.

In the following table is given the azimuth and altitude of the sun for 42° north latitude at each hour of the day for the typical periods of the year.

TABLE I

Hour angle.	Winter solstice.		Equinoxes.		Summer solstice.	
	Azimuth.	Altitude.	Azimuth.	Altitude.	Azimuth.	Altitude.
5-7 105°	117°-10'	5°-9'
6-6 90°	90°-0'	0°-0'	107°-52'	15°-27'
7-5 75°	79°-50'	11°-5'	98°-46'	26°-17'
8-4 60°	52°-49'	4°-17'	68°-53'	21°-49'	89°-12'	37°-23'
9-3 45°	41°-38'	12°-28'	56°-13'	31°-42'	77°-58'	48°-27'
10-2 30°	29°-0'	18°-55'	40°-47'	40°-4'	62°-47'	58°-57'
11-1 15°	14°-58'	23°-6'	21°-49'	45°-52'	38°-36'	67°-38'
12 0°	0°-0'	24°-33'	0°-0'	48°-0'	0°-0'	71°-27'
Sunrise and sunset.						
4 h. 28 m.	57°-37'	0°-0'
6 h. 0 m.	90°-0'	0°-0'
7 h. 32 m.	122°-23'	0°-0'

EXPLANATION OF TABLE.

The first column gives the solar time expressed in hour angles, one hour being equal to 15 degrees, reckoning either way from noon. For instance, the hour angle 30 degrees corresponds to 10 A.M. or 2 P.M., the hour angle 45 degrees to 9 A.M. or 3 P.M., and so on. Azimuth is east of south for the forenoon and west of south for the afternoon.

No corrections have been made for refraction, the effect of which is to slightly increase the altitude when the sun is near the horizon.

This table is the basis on which all of the diagrams in this book have been constructed.

Similar tables, computed for the latitudes of London and New Orleans, will be found in the appendix.

CHAPTER II

SHADOW DIAGRAMS

As the first example of the application of the data obtained in the preceding chapter, let us consider the shadows cast by two cubes, one of them placed with its four sides facing the cardinal points, and the other with its diagonal upon the meridian.

These shadows are shown in Figs. 8, 9, and 10 and are given for each hour of the day at the typical periods of the year.¹

It is evident that in the first position the north face of the cube receives no sunlight during one-half the year, from the autumnal to the vernal equinox, whereas in the second position all four faces receive sunlight at some portion of each day, throughout the year.

There is another advantage, not inconsiderable, in the latter arrangement, since in this position the cube shades the surface of the ground considerably less than when it is placed squarely facing the cardinal points.

A study of the diagrams will make this apparent.

It will be noted that in the lower diagrams of each figure the shadows overlap each other to a greater extent than they do in the upper ones and furthermore that in the lower diagram of Fig. 8 there is a triangular area which receives no sunlight at all.

¹ These diagrams and all those which follow are drawn for latitude $42^{\circ}-0'$ north.

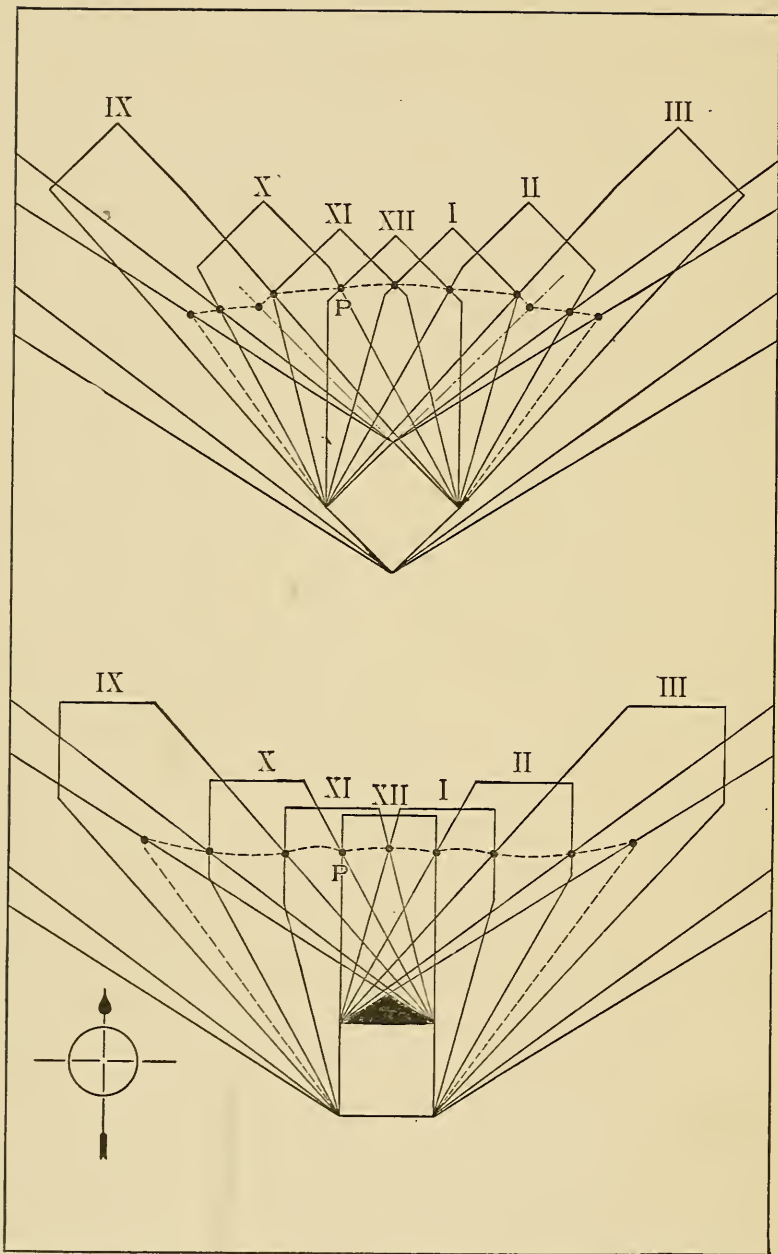

FIG. 8. — Shadows of the cube, winter solstice. The shaded area in the lower diagram receives no sunlight. Lat. $42^{\circ}-0'$ N.

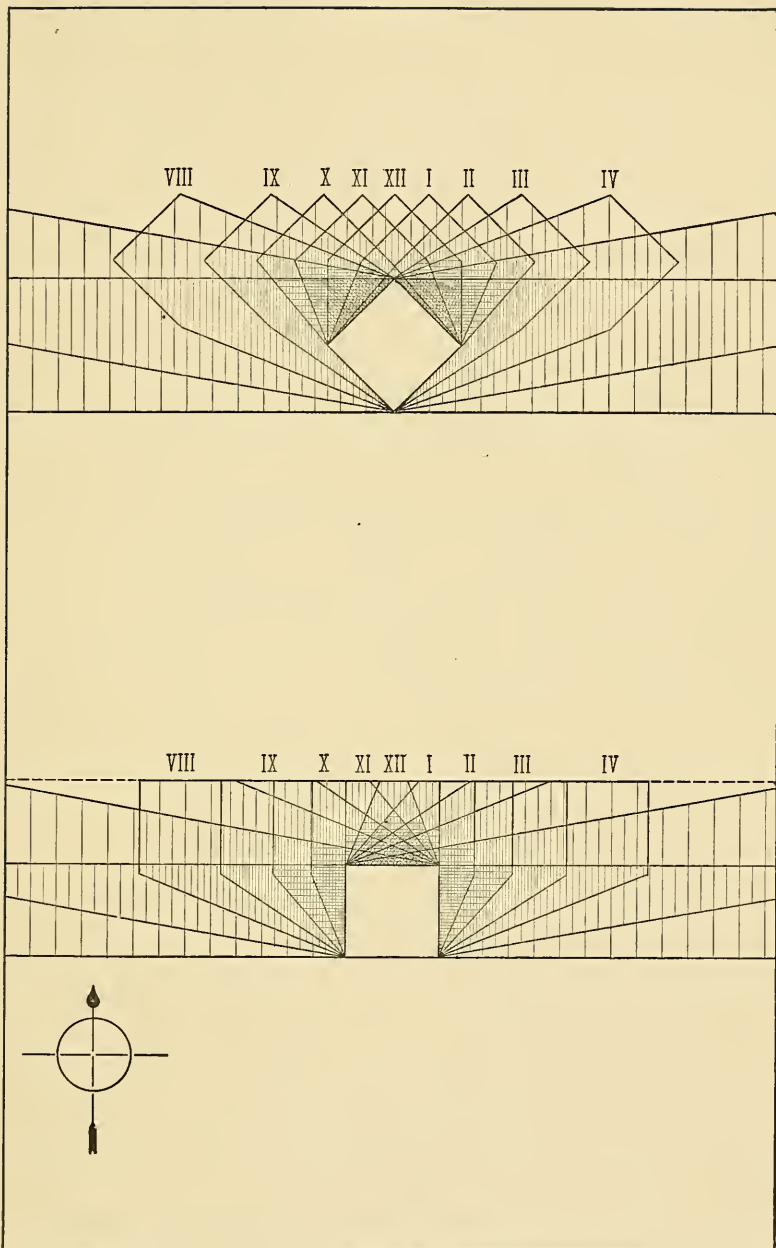

FIG. 9. — Shadows of the cube, autumnal and vernal equinox. Lat. $42^{\circ}-0'$ N.

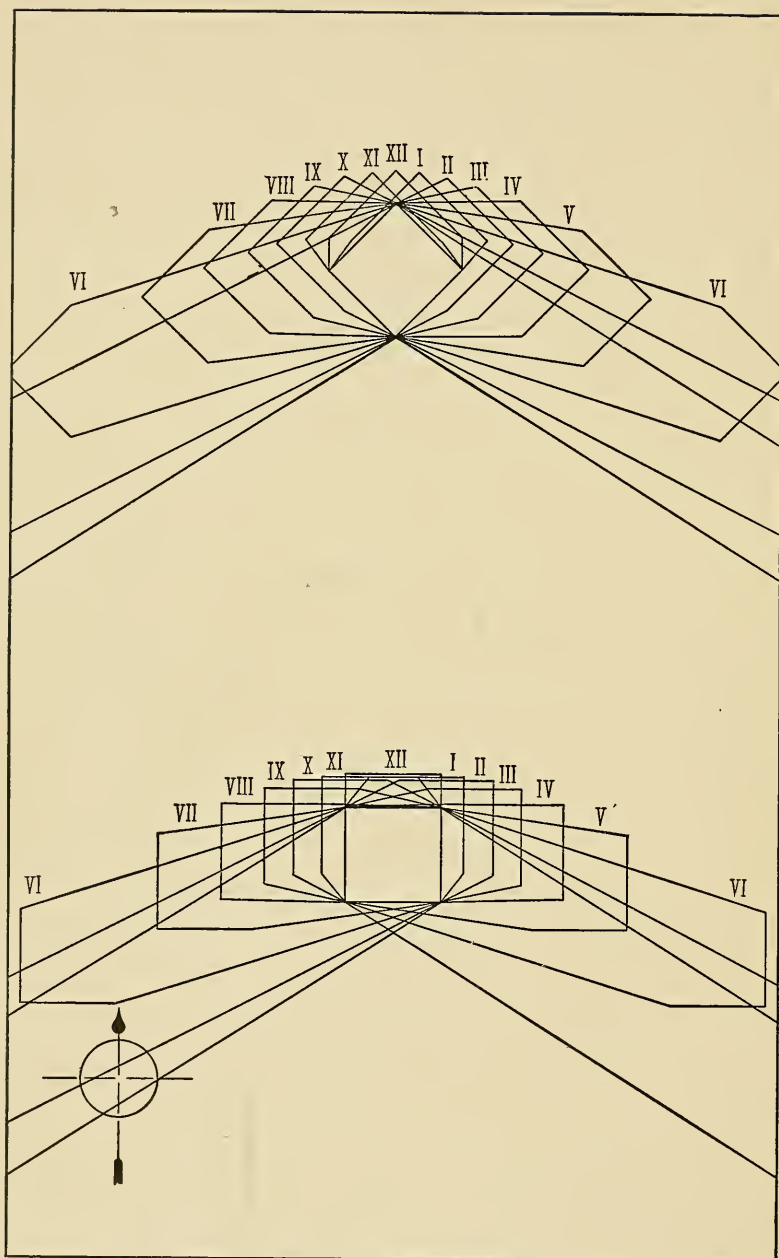

FIG. 10. — Shadows of the cube, summer solstice. Lat. $42^{\circ}-0' N.$

The advantage of placing a square building with its diagonal upon the meridian was long ago recognized by the mountain dwellers of Switzerland.

The ground plan of a typical Swiss dwelling is shown in Fig. 11.¹

It will be observed that the living room is placed in the sunniest corner of the building, with its windows facing southeast and southwest.

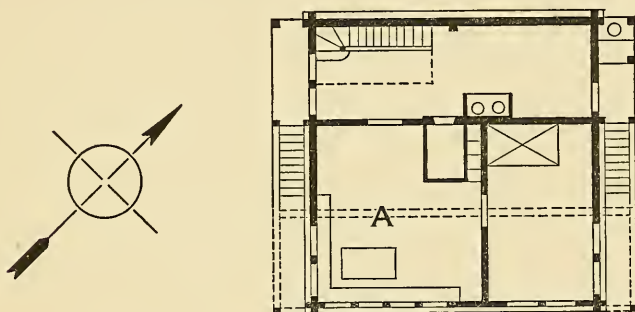

FIG. 11. — Ground plan of Swiss dwelling, showing the customary orientation. A is the Living Room.

Referring again to the shadows of the cube it will be observed that at the equinoctial periods the tips of the shadows move in a straight line from west to east, whereas at all other seasons they describe a curve.

A further study of the diagrams will show that other curves are contained in them besides those described by the tips of the shadows, and in one of the diagrams such a curve is shown, passing through certain points of intersection of the shadows, those points having been selected

¹ Taken from *Die Holz-Architectur der Schweiz*. Gladbach. Zurich and Leipzig, 1885.

which are in shadow for exactly two hours, as, for instance, the point *P*, which first comes into shadow at 10 A.M., and emerges again at noon. And a study of the diagram (Fig. 8) will show that each of the other points is in shadow for the same length of time.

Such a curve may be called a "shadow curve," and the curve of our figure the "two-hour shadow curve." In the same way we might draw the "three-hour" and the "four-hour shadow curve," and so on, until our original drawing should become translated into a new and strange diagram, consisting entirely of curves.

It is in this manner that the following diagrams have been drawn (Figs. 12 to 17).

To express more clearly their meaning, the zones between the curves have been shaded in a series of tints, corresponding to the following table:



Area in sunlight between 9 and 8 hours.

Area in sunlight between 8 and 7 hours.

Area in sunlight between 7 and 6 hours.

Area in sunlight between 6 and 5 hours.

Area in sunlight between 5 and 4 hours.

Area in sunlight between 4 and 3 hours.

Area in sunlight between 3 and 2 hours.

Area in sunlight between 2 and 1 hour.

Area in sunlight for less than 1 hour.

Area without sunlight.

These diagrams not only illustrate, in a graphic manner, the effect of the object or building, in shading the ground around it, but they also indicate the distribution of sun-

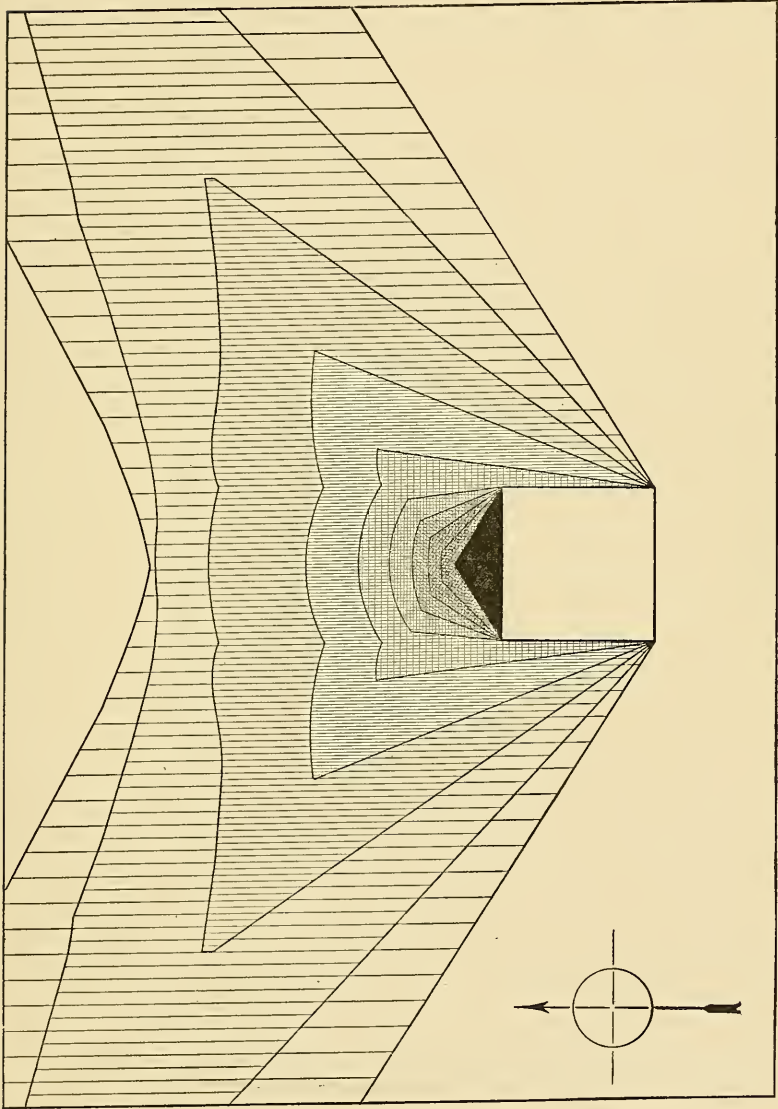

FIG. 12.—Shadow curves of the cube, winter solstice. The area in solid black receives no sunlight. Lat. 42° - $0'$ N. The method of obtaining these curves is illustrated in Fig. 8.

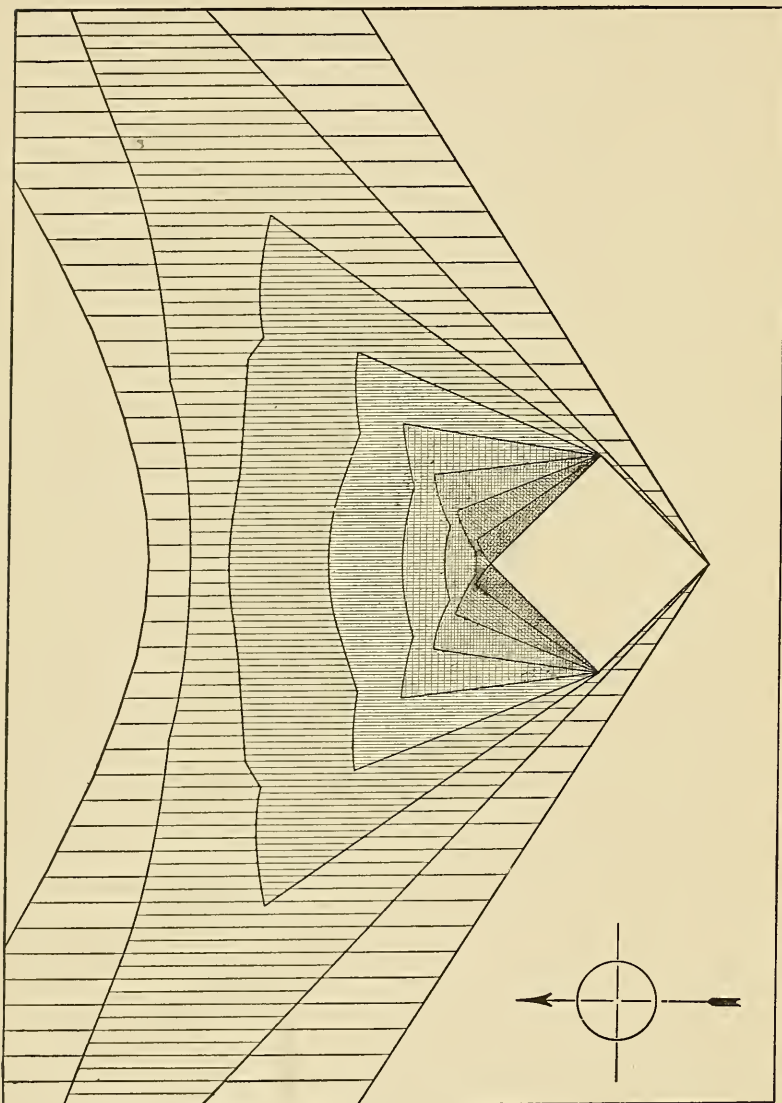

FIG. 13.—Shadow curves of the cube, winter solstice. Lat. $42^{\circ}-0' N$. Contrast this diagram with the preceding. One of these curves is shown in Fig. 8.

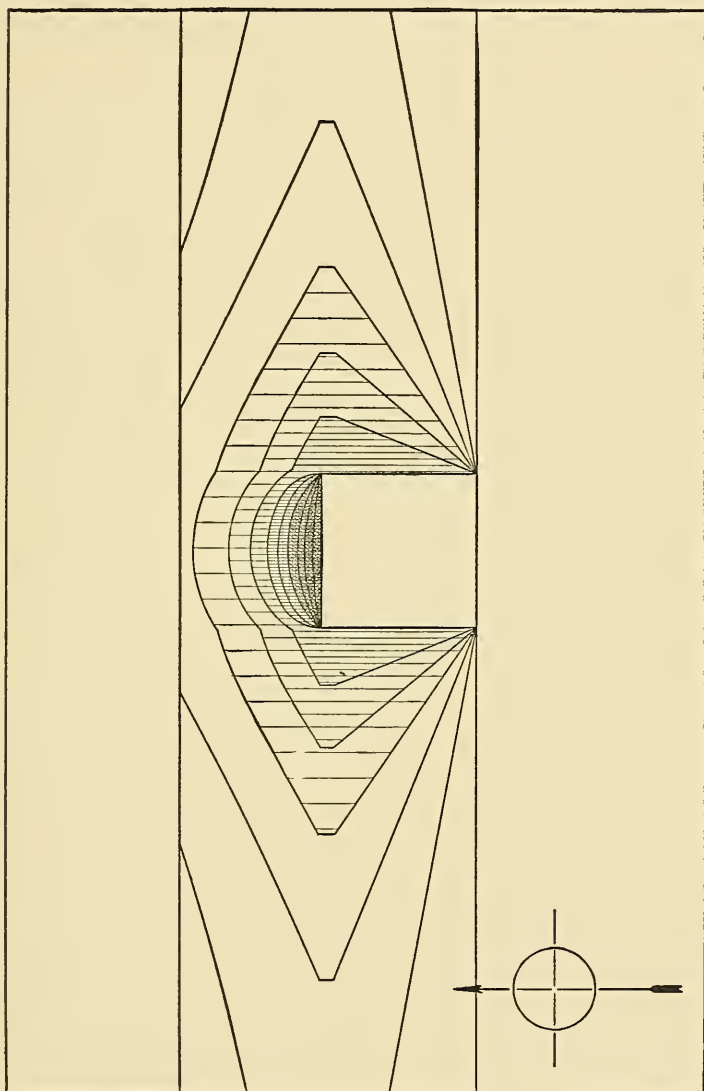

FIG. 14. — Shadow curves of the cube, autumnal and vernal equinox. Lat. 42° - $0'$ N.

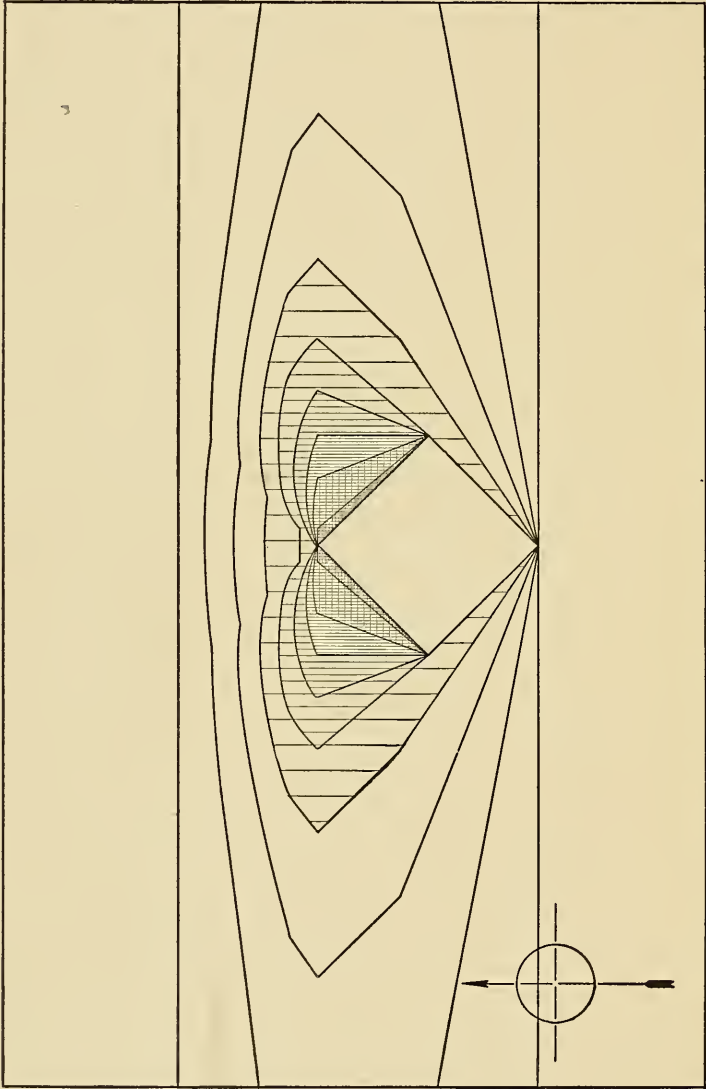

FIG. 15. — Shadow curves of the cube, autumnal and vernal equinox. Lat. 42° - $0'$ N

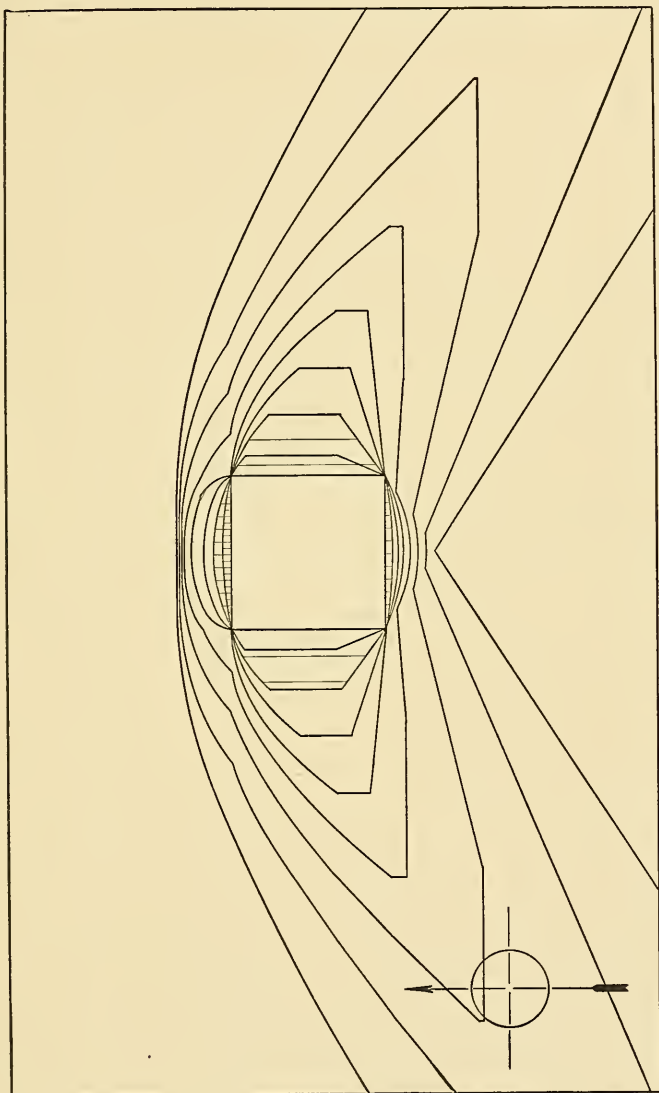

FIG. 16. — Shadow curves of the cube, summer solstice. Lat. 42° - $0'$ N.

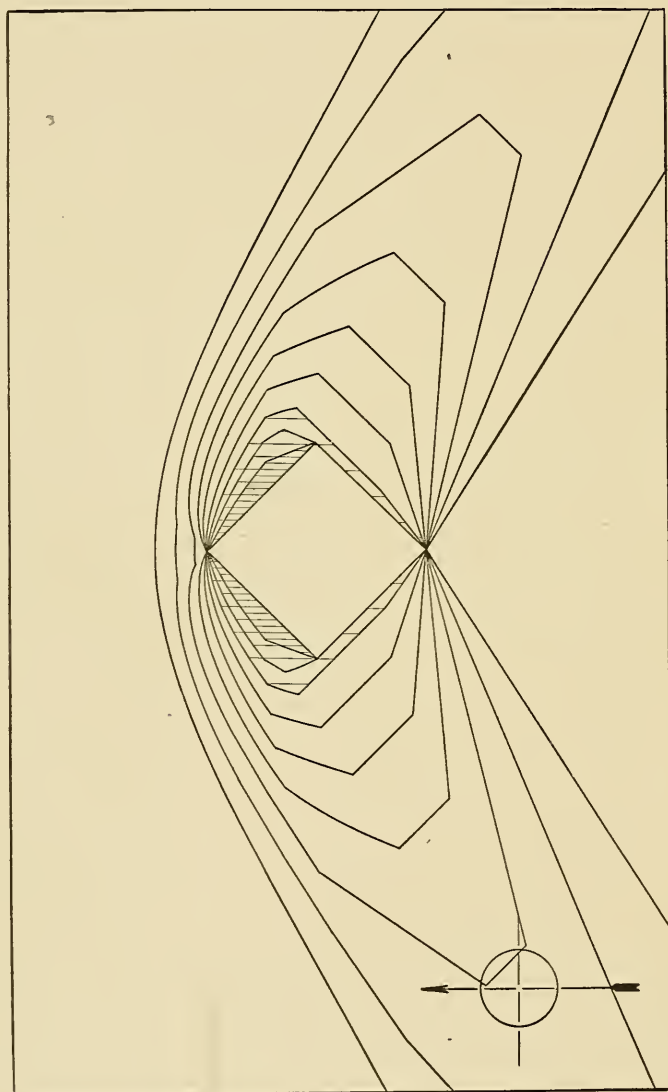

FIG. 17. — Shadow curves of the cube, summer solstice. Lat. $42^{\circ}-0' N.$

light upon the vertical surfaces, or walls, of the building itself.

In the same manner the shadow curves of any object or building may be obtained.

The process affords a useful exercise in descriptive geometry, and the results are interesting and instructive. To reproduce the complete series of shadow curves for each type of object or building which we shall study would, however, require an unduly large number of diagrams.

It becomes desirable therefore to devise a method which will present the subject in a more condensed form.

Such a method has been adopted for the diagrams which follow, and the manner of their construction will now be explained.

In the discussion of the shadow curves of the cube, it was pointed out that one of the diagrams differed essentially from the others in that it disclosed an area having no sunlight at all during the day.

Such an area will be called an *area of complete shadow* and may be defined as follows:

The *area of complete shadow* of any object reposing upon a horizontal plane surface is that portion of the object, and of the surface upon which it rests, which is continuously in shade at the particular period of the year under consideration, and an *area of perpetual shadow* is that portion of the surface which receives no direct sunlight at any time during the year.

It is evident that by superposing the *areas of complete*

shadow for different seasons, we may, in a single diagram, embrace the phenomena of an entire year.

And this has been done in the following diagrams (Figs. 18, 19, and 20) in which the waxing and the waning of the *area of complete shadow* is shown by indicating its size at periods one month apart throughout the year.

These diagrams show the *area of complete shadow* for the three fundamental types of building plan: the single straight block (of which the cube is a particular case),

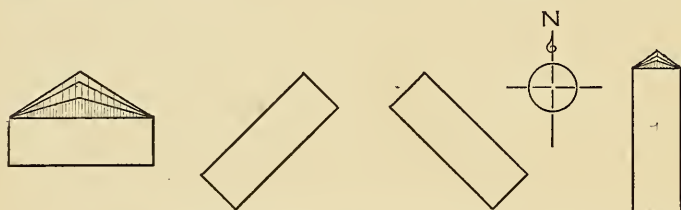

FIG. 18. — Areas of complete shadow; single straight block. Lat. $42^{\circ}-0'$ N.

two blocks arranged as an L, and three blocks arranged as a U.

As almost all buildings are composed, in their elements, of these simple shapes, in various combinations, it follows that a careful study of these diagrams will enable one to criticize intelligently, as far as concerns the orientation, the plan of almost any building.

In the single straight block (Fig. 18) it will be seen that there is an *area of complete shadow* present in two of the positions shown.

This area first appears on September 21 and increases in size up to December 21, after which it decreases, until by March 21 it has disappeared altogether.

In the other two positions the absence of an *area of complete shadow* indicates that each wall of the building and all portions of the ground around it receive sunlight at some period of the day throughout the year.

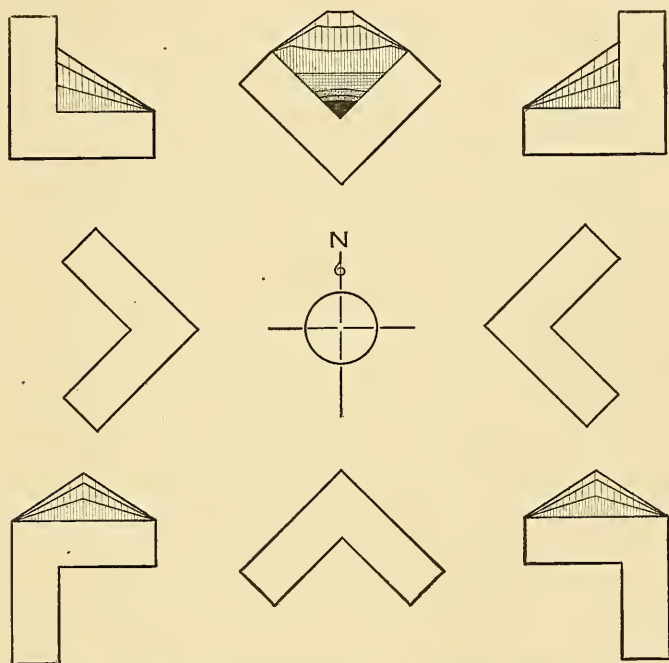

FIG. 19. — Areas of complete shadow; two blocks arranged as an L. The solid black represents the area of complete shadow at the summer solstice, the lightest tint the area of complete shadow at the winter solstice, and the intermediate tints the areas of complete shadow at intervals one month apart for the intervening periods of the year. Lat. $42^{\circ}-0'$ N.

In the case of the L plan (Fig. 19) there is one position (that in which the re-entrant angle faces the north) in which an *area of perpetual shadow* first appears, and in the U plan (Fig. 20) there are three such positions,

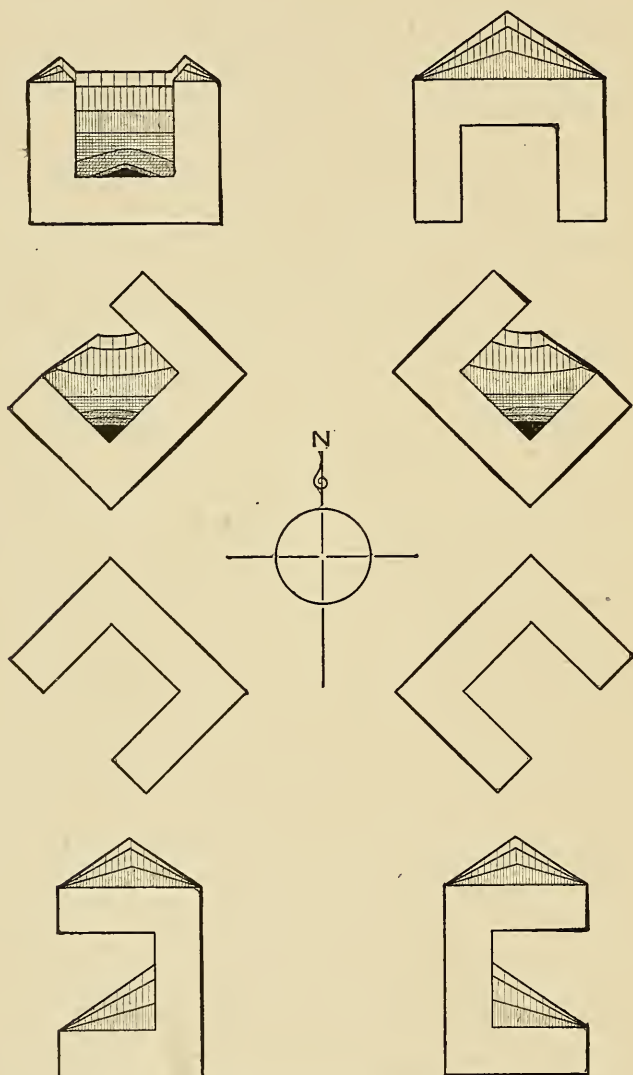

FIG. 20. — Areas of complete shadow; three blocks arranged as a U.

The height of the blocks in these three diagrams (Figs. 18, 19 and 20) is taken as equal to their width. Lat. $42^{\circ}-0' N$.

those in which the U court faces north, northeast, and northwest.

The significance of these diagrams will perhaps be better understood by a study of Fig. 21, which illustrates the method of obtaining the *area of complete shadow* for the L plan.

In all of the foregoing diagrams the height of the blocks is assumed to be equal to their width.

The effect of an increase in height will now be considered.

As the first example we will take the cube and compare its shadow diagram with that of a square prism having a height, let us say, equal to five times the width. We may imagine the one to represent a building 60 feet square and 60 feet high, and the other a tower 60 feet square and 300 feet high.

The diagrams (Fig. 22) represent the shadow curves of the two at the winter solstice.

It will be noted that the increase in height enlarges the outer series of curves but does not affect those in the immediate vicinity of the building, and, furthermore, that the *area of complete shadow* is the same in both cases. An increase of height of the single straight block produces a similar effect.

In certain positions of the L and U plans, however, an increase of height produces an enlargement of the *area of complete shadow* up to a certain point, beyond which any further increase produces no further change in the *area of complete shadow* upon the ground.

It must be remembered, however, that the presence of

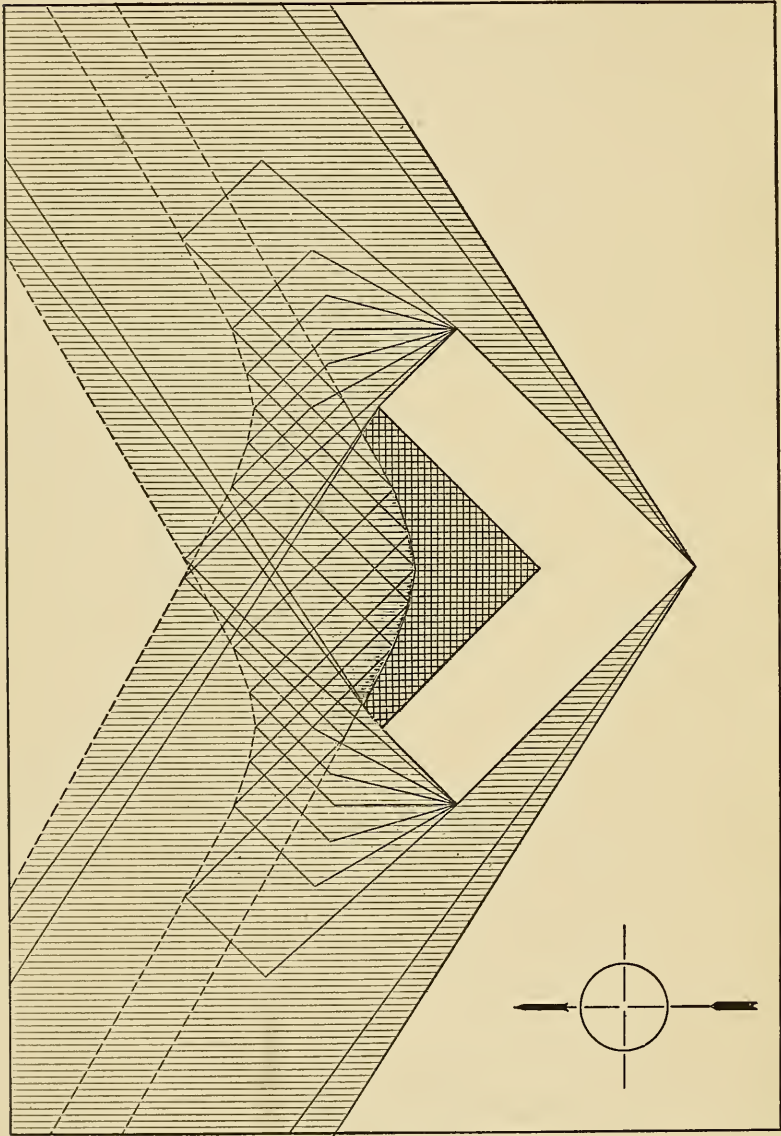

FIG. 21. — Showing method of obtaining the area of complete shadow. The height of the block is taken at one-half its width. Note that in Fig. 19 the height of the block is taken as equal to its width. Winter solstice. Lat. 42° - $0'$ N.

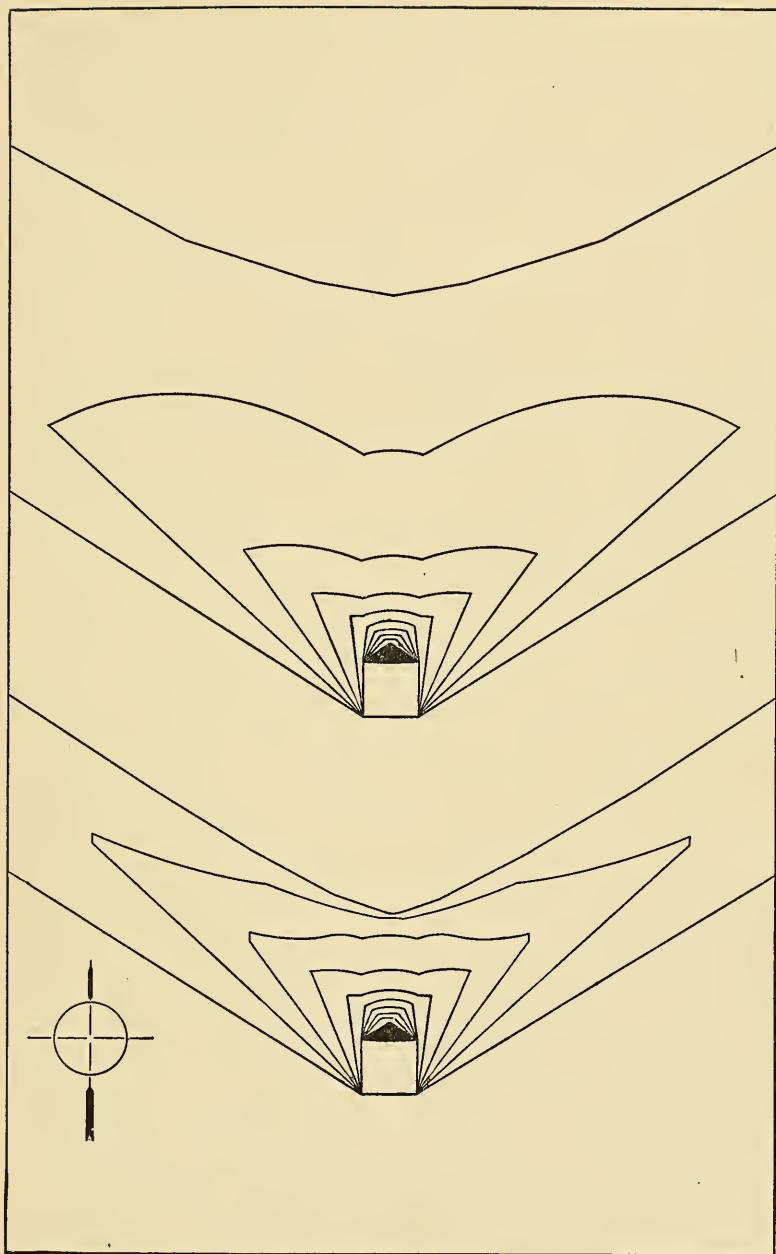

FIG. 22. — Showing the effect of an increase of height upon the shadow curves. The lower diagram represents a cube, and, at a smaller scale, is identical with Fig. 12. The upper diagram represents a prism of a height equal to five times that of the cube. Winter solstice, Lat. $42^{\circ}-0'$ N.

an *area of complete shadow* in plan indicates that it also extends over a portion of the walls of the building.

The maximum *areas of complete shadow* for the L and U plans produced by an increase in height, are shown in Fig. 23, and in Fig. 24 is shown in isometric projection the *area of complete shadow* of the L plan, in that position of the L in which the reëntrant angle faces the north.

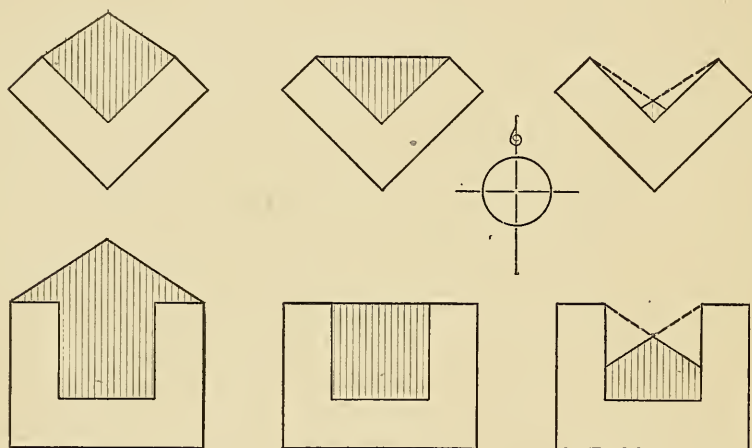

FIG. 23. — Showing the maximum areas of complete shadow for the L and U plans. The diagrams at the left represent the winter solstice; at the right, the summer solstice, and between the two, the vernal and autumnal equinox. Lat. $42^{\circ}-0' N$.

It is of course to be understood that these positions of the L and U plan are undesirable.

For example, let us imagine that we are planning a country dwelling of the farm-house type. The main portion of the building has been correctly placed at an angle of 45° with the meridian and the question before us is the position of the L or wing, containing the kitchen

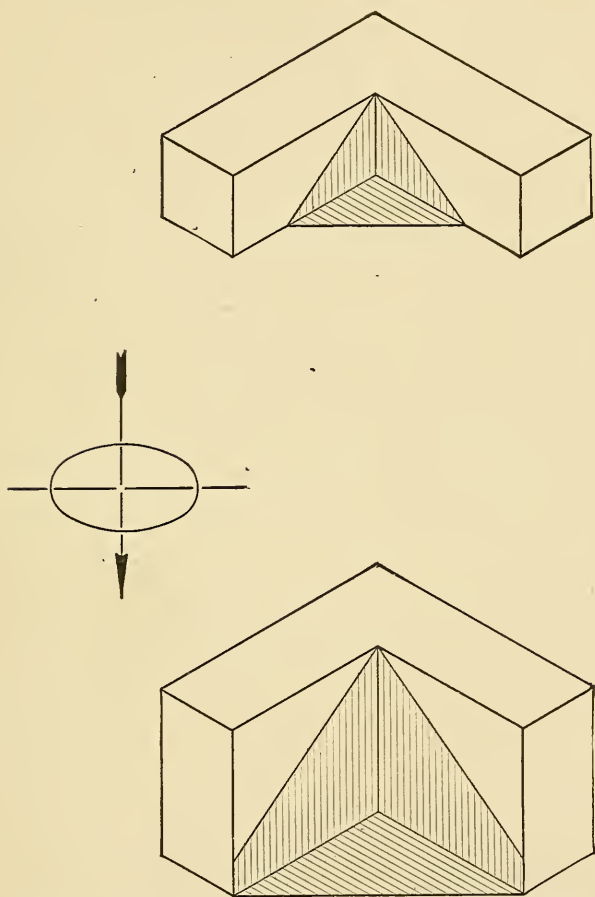

FIG. 24. — Areas of complete shadow for the L plan, autumnal and vernal equinox, showing the effect of an increase of height. Lat. 42° N.

and shed (Fig. 25). Of the two arrangements shown in the figure the lower is to be preferred, since in the upper there is a reëntrant angle facing the north, involving an *area of complete shadow* at all seasons of the year.

The presence or absence of an *area of complete shadow* is a useful criterion by which to judge of the excellence of any given plan, and it is a test which should always be applied in studying a group of buildings or in planning a building having a number of courts or wings.

To determine the *area of complete shadow* at the equinoctial periods is a simple matter, since at this time the trace of the sun's rays describes a plane, and the tips of the shadows of any object cast upon level ground move in a straight line from west to east, as we have already seen in the shadows of the cube.

As an example let us apply this test to a type of plan which is quite a common one for institutional buildings (Fig. 26).

It will be found that, in any position in which this plan may be placed, there is an *area of complete shadow* always present.¹

In all the cases so far considered, it will be observed that the positions which give the least amount of shaded area are those in which the blocks or buildings are placed at an angle of 45° with the meridian.

¹ In making the sun plan of a building care must be taken to distinguish between the magnetic north and the true meridian. It is customary in surveyors' plans to mark the magnetic north by the symbol of a one-sided arrow, while the true north is denoted by a full-fledged arrow.

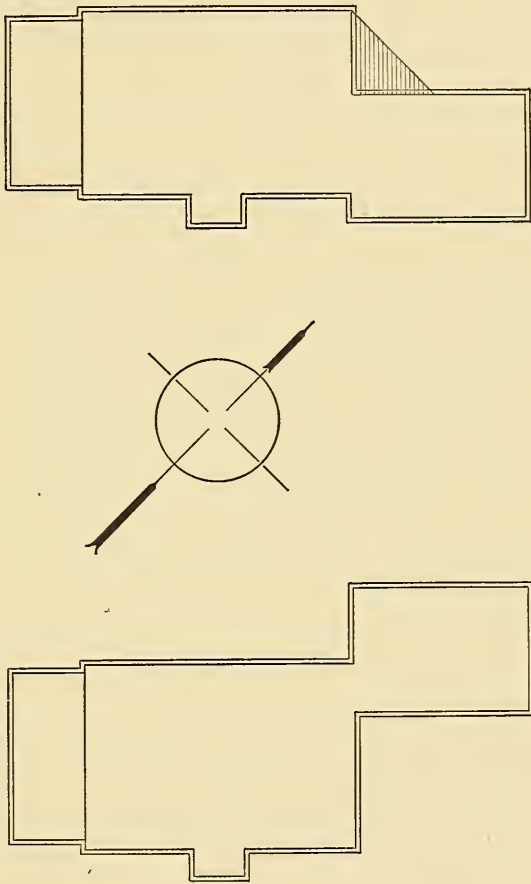

FIG. 25. — Good and bad arrangement of L. The shaded area in the upper part of the figure shows the area of complete shadow at the autumnal and vernal equinox. Lat: $42^{\circ}-0'$ N.

The next step in our study will be to consider the grouping of buildings, such a problem, for instance, as is presented in planning a pavilion hospital.

In studying groups of buildings we have not only to consider the shadows cast by the buildings upon the ground,

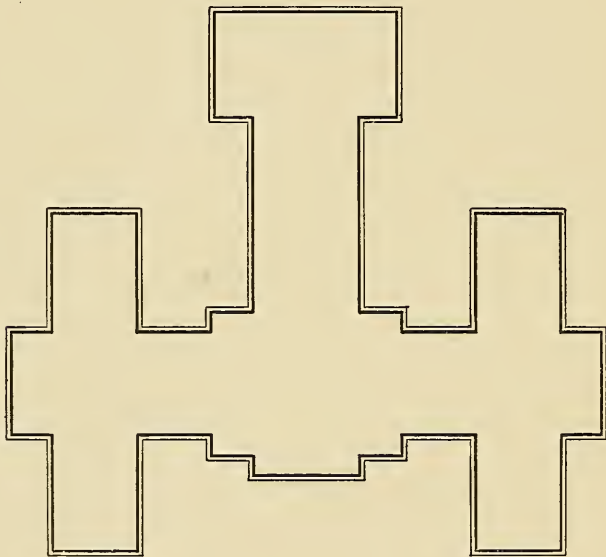

FIG. 26. — This is a common type of plan for hospitals and other institutional buildings. It is given here as an example to be avoided, since it involves an area of complete shadow in any position in which it may be placed.

but also the shadows cast by the different buildings upon each other. Figs. 27, 28, and 29 represent, in isometric projection, two of our single straight blocks placed side by side, with the shadows as they would be at the winter solstice, when the interference of one building with another is the greatest.

In Fig. 27 the long axis of the blocks runs north and south; in Fig. 28 east and west, and in Fig. 29 northeast and southwest.

The latter figure will also serve for the case in which the axis of the blocks runs northwest and southeast, the forenoon diagrams of the one corresponding to the afternoon diagrams of the other, and *vice versa*.

The blocks are placed at a distance apart equal to twice their height, the arrangement usually recommended for the ward pavilions of a hospital.

A study of these diagrams which, as above noted, represent the most unfavorable conditions of the whole year, justifies the conclusion that adequate sunlight may be obtained with a distance between the blocks of considerably less than that shown.

Such is the kind of study which the architect must pursue in order to become proficient in the art of sun-planning.

How much weight should be given to the question of sunlight must be a matter for judgment in each case, but to wilfully create an *area of complete shadow* when, by some different arrangement of plan, it might have been avoided, without detriment to more important considerations, cannot be considered good architecture.

Just as a building should be planned in all its parts so as to shed water, and not invite the entrance of dampness into its exterior walls, so in its general shape and disposition it should be planned so that the sun may dry out its walls quickly after rains, and keep them clean and bright.

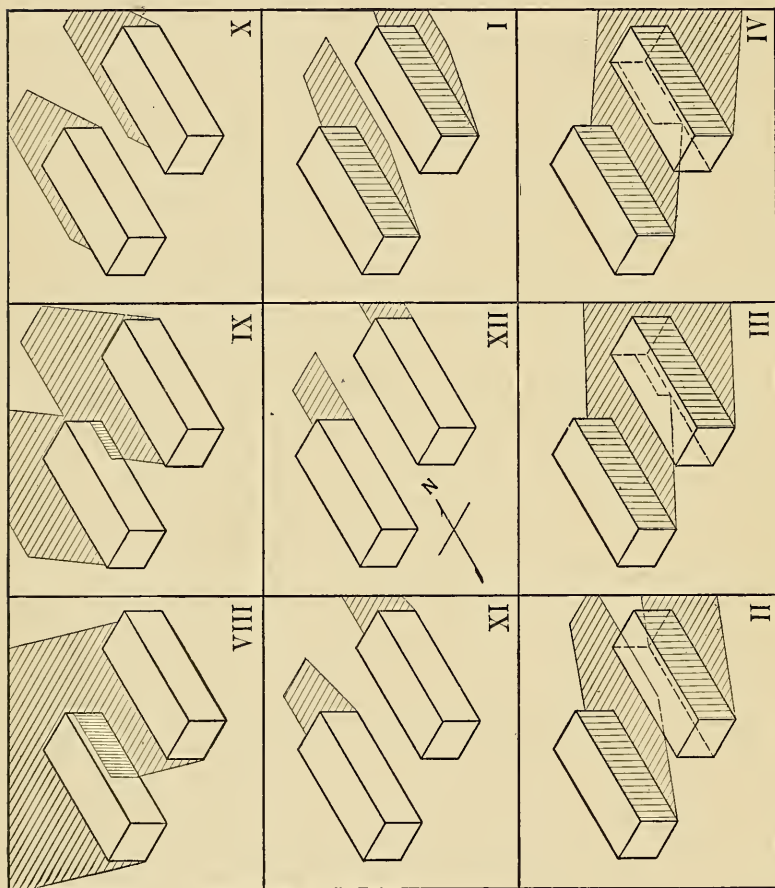

FIG. 27. — Showing the shadows cast by two single straight blocks side by side; winter solstice; Lat. 42° N.

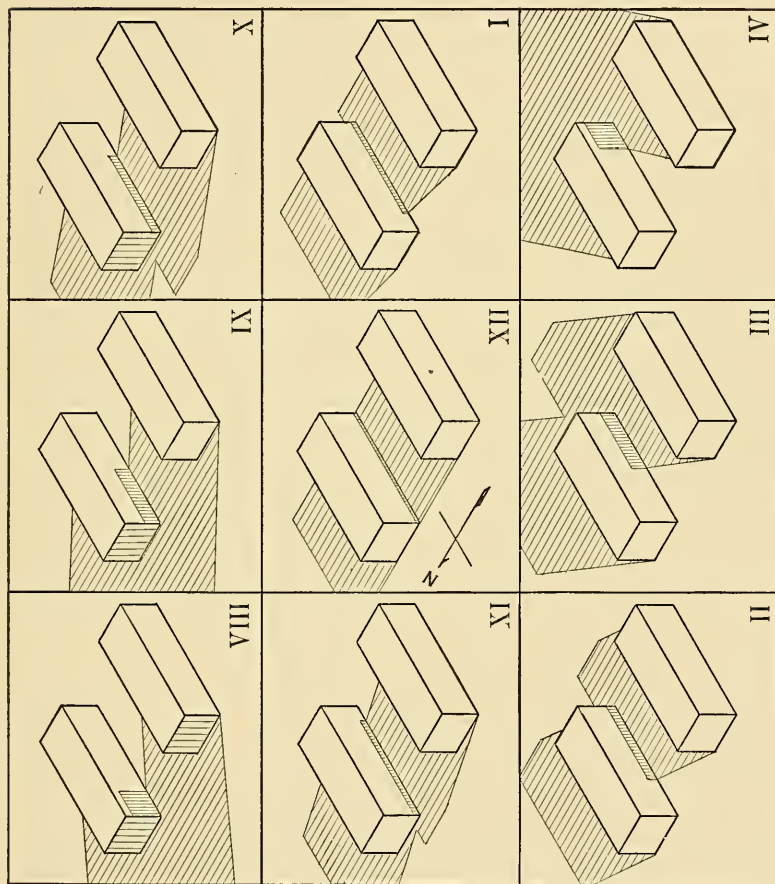

FIG. 28. — Showing the shadows cast by two single straight blocks side by side; winter solstice; Lat. $42^{\circ}-0' N$.

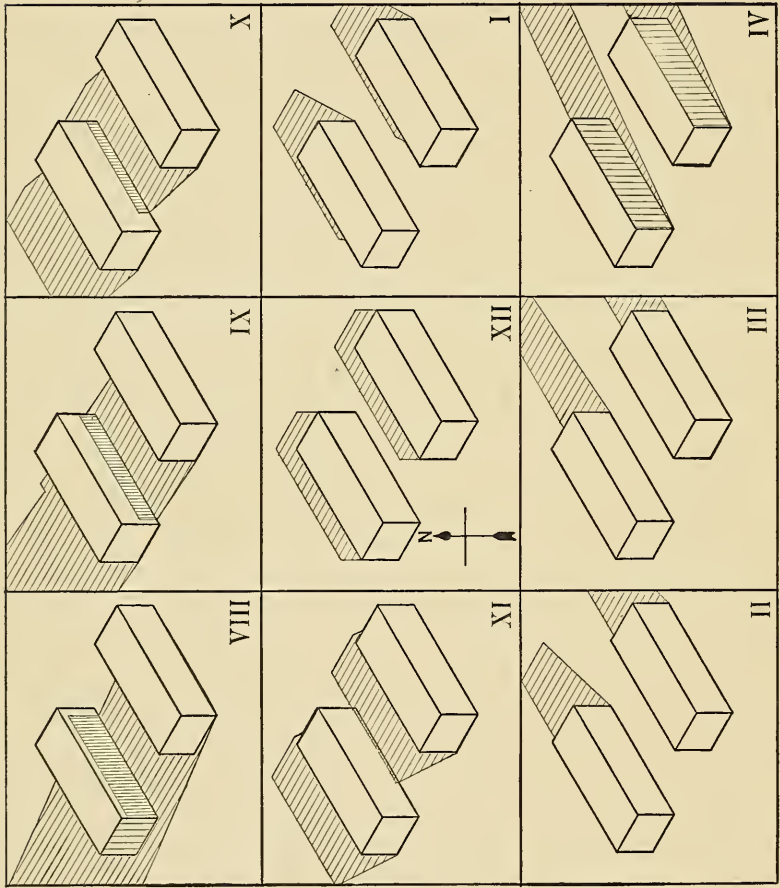

FIG. 29. — Showing the shadows cast by two single straight blocks side by side; winter solstice; Lat. 42° N.

So far we have considered only the distribution of sunlight upon the exterior surfaces of buildings and upon the ground. The admission of sunlight to the interior of buildings through windows will next be considered.

It is evident that a window facing the east, and with an unobstructed outlook, will receive its maximum of sunlight at sunrise of the equinoctial periods.

As the sun moves toward the south and mounts higher and higher in the heavens, his rays fall more and more obliquely

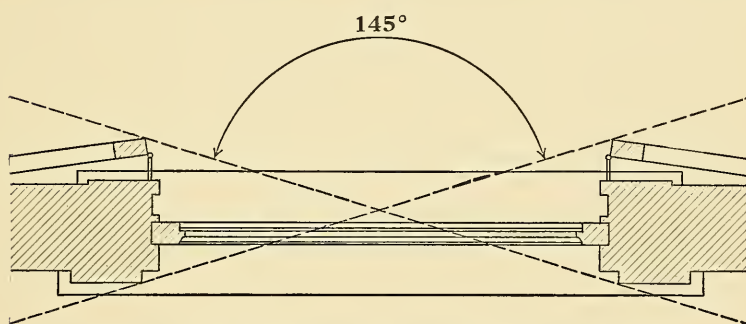

FIG. 30. — Showing the visual angle of an ordinary window, in a building of frame construction.

through the opening, and finally cease to come through at all. The angle at which this will occur varies with the width and height of the opening and the depth of the jamb.

Fig. 30 is the plan of a window of ordinary width in a wall of frame construction. The angle of 145° shown upon the diagram may be called the *visual angle* of the window.

If the thickness of the wall is increased the visual angle is restricted and consequently the length of time during which the window will admit sunlight is diminished.

By increasing the width of the opening the visual angle may be enlarged but will always be less than 180° .

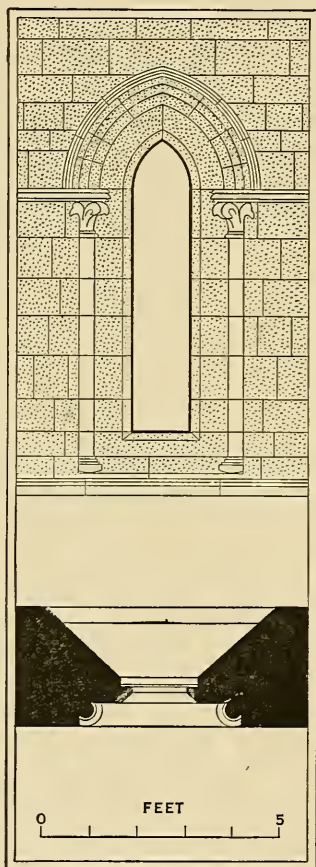

FIG. 31. — Chancel window, Great Casterton Church, Rutland; from *An Analysis of Gothic Architecture*, by R. and J. A. Brandon. London, 1849.

The full visual angle of 180° can only be obtained in the oriel or bay window. We are accustomed to think of bay windows as having a southerly exposure, when, as a

matter of fact, their greatest usefulness is found when they are projected from the north side of a building to catch the oblique rays of the morning sun, which would be shut out of a window set in the plane of the wall.

Bay windows are of great use also for city buildings upon narrow streets, where the buildings opposite shut out the sunlight except when it falls in an oblique direction from either side.

The visual angle of a window may be increased by beveling the jambs, with the advantage that the light is increased without any increase in the glass surface, and consequent loss of heat by radiation.

The advantage of the beveled jamb was well understood by the mediæval builders (Fig. 31).

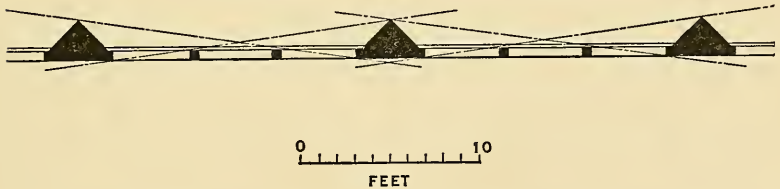

FIG. 32. — Wall section of factory building on Swett St., Boston.

Fig. 32 illustrates the wall section of a factory building designed by the author, in which the piers between the windows are reduced to a minimum width and are also beveled, affording the maximum of light.

For the following series of window diagrams a window has been assumed 3 ft.-6 in. wide, and 8 ft.-0 in. tall, with a wall thickness of 1 ft.-0 in., giving a visual angle

of $148^{\circ}-6'$ and a normal area of opening of 28 square feet.

The diagrams (Figs. 33 to 35) represent the plan of a room 24 feet square, lighted by a single window of the dimensions given and with the window sill at a height of 2 feet above the floor.

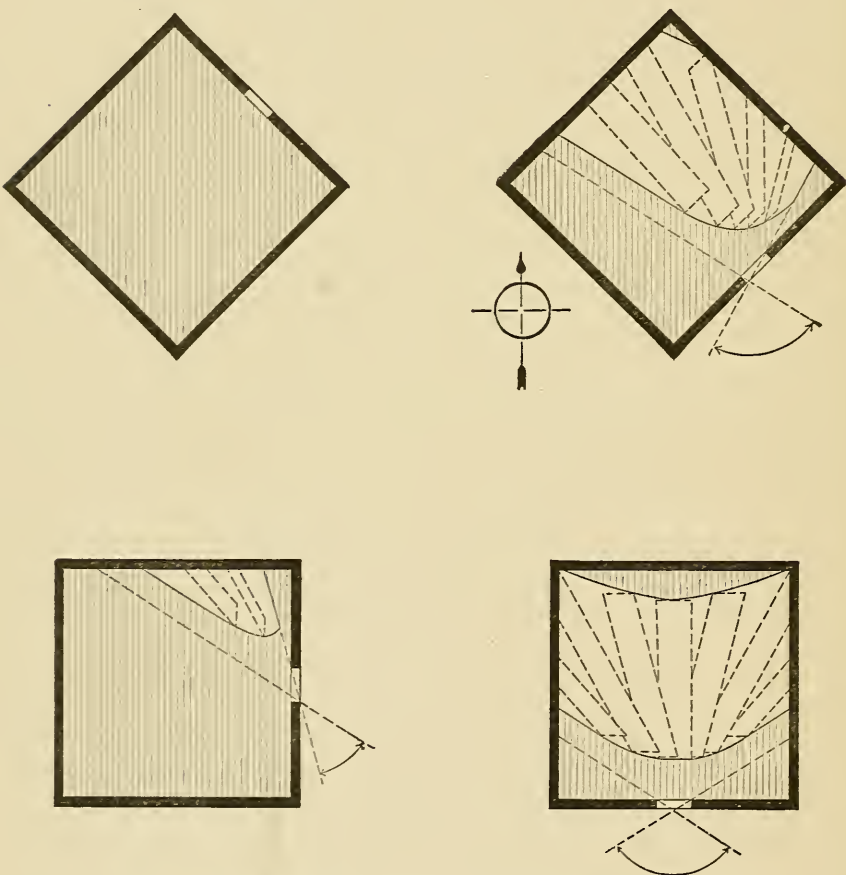

FIG. 33. — Showing the area of floor subject to direct sunlight, for windows of different aspects; winter solstice; Lat. $42^{\circ}-0'$ N.

The parallelograms in dotted lines, somewhat resembling a deformed pack of cards spread upon the floor, indicate the areas in sunlight at successive hours, and the curved figures resulting therefrom the whole area subjected to

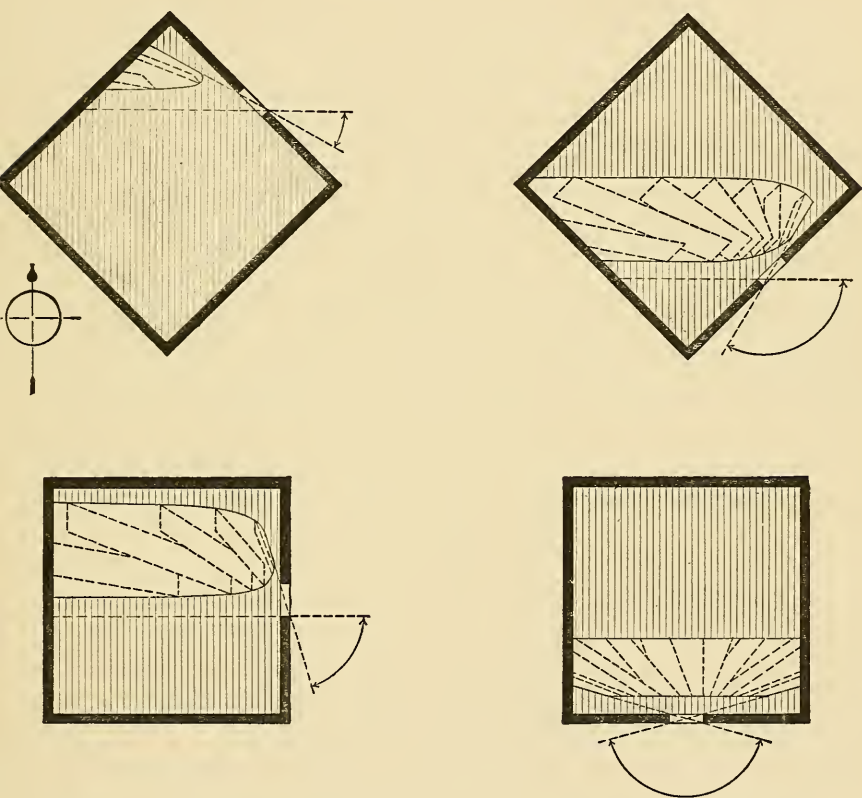

FIG. 34. — Showing the area of floor subject to direct sunlight, for windows of different aspects; autumnal and vernal equinox; Lat. $42^{\circ}-0'$ N.

sunlight, for the various exposures and at the various seasons indicated.

If the room of our diagram were carpeted with a dark material having the property of becoming instantly bleached by exposure to direct sunlight, it would present

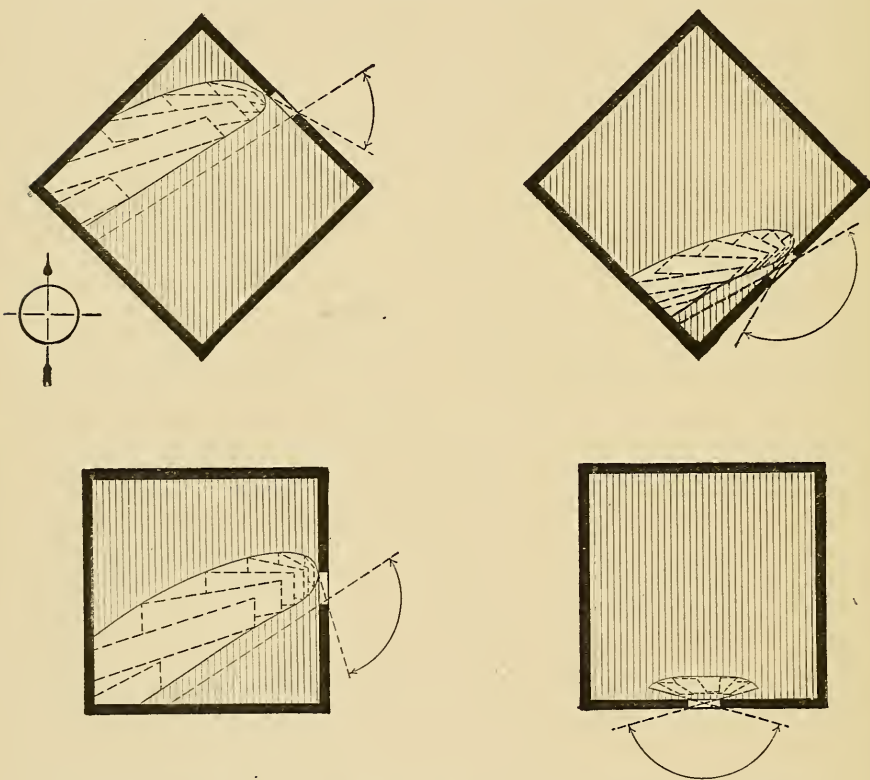

FIG. 35. — Showing the area of floor subject to direct sunlight, for windows of different aspects; summer solstice; Lat. $42^{\circ}-0'$ N.

an appearance at the end of the day corresponding to these diagrams.

The rays of sunlight passing through any aperture, as a window, form a prism, the cross section of which changes as the angle of sunlight changes. The area of such a cross section is the normal area of the aperture for the admission of sunlight at the particular instant at which it is taken. The cross section of such a prism may be found by descriptive geometry.

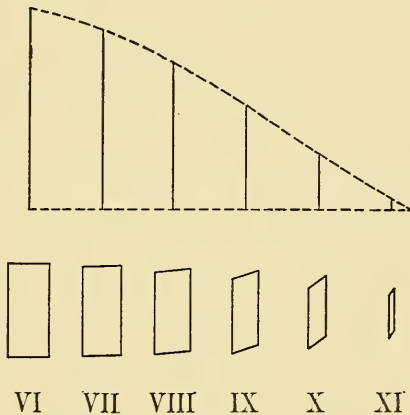

FIG. 36. — The parallelograms in the lower part represent the cross sections of the sunlight prism of an east window, for the hours indicated, at the autumnal and vernal equinox. The figure in the upper part is a graphic representation of the total quantity of sunlight admitted by the window, and is identical with the corresponding one of Fig. 38, but at a larger scale. Dimensions of window: 3 ft.-6 in. wide, 8 ft.-0 in. tall, and 1 ft.-0 in. wall thickness.

The parallelograms in the above diagram (Fig. 36) represent the cross sections of the sunlight prism of an east window of the dimensions assumed, taken at intervals of one hour, at the period of the equinoxes.

The areas of these sections are as follows:

A.M.	Square Feet.
6	28.00
7	25.05
8	20.39
9	14.50
10	7.86
11	1.35
11.17	0.

These areas may be represented by lines of varying length and are so represented by the vertical lines above them.

Joining the extremities of these lines by a curve, we obtain a figure the height of which at any point will represent the area of the sunlight prism at the corresponding hour, and the area of the whole figure the total amount or *quantity* of sunlight admitted by the window during the day.

It is in this manner that the figures of the succeeding diagrams (Figs. 37, 38, and 39) have been drawn.¹

In order to compare these areas we will take as a unit the quantity of sunlight which passes through an opening one foot square, in a plane normal to the sun's rays, in one hour.

The areas of the figures may then be expressed in terms of this unit, which for convenience we will call a *sun hour*, as in Table II.

The heating effect of the *sun hour* will, of course, vary with the altitude of the sun and atmospheric condi-

¹ Each division of the vertical scale in these figures corresponds to ten square feet.

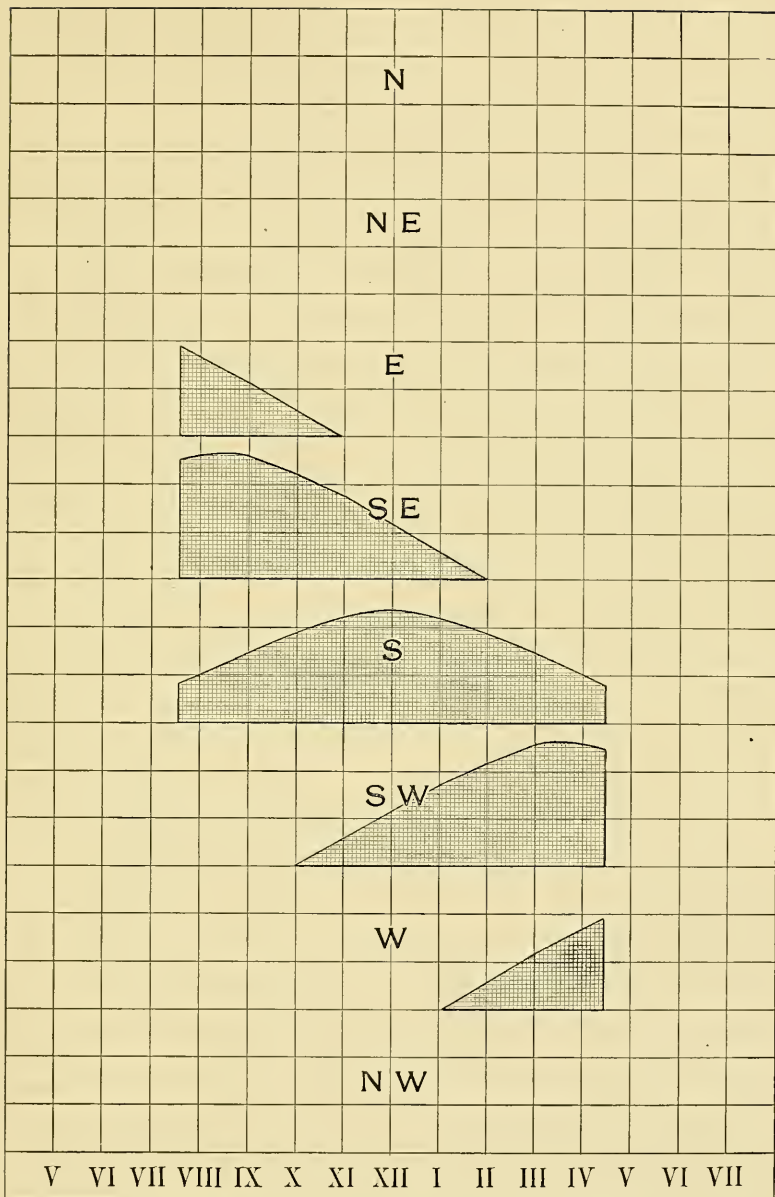

FIG. 37. — Showing the quantity and duration of direct sunlight admitted by windows of different exposures; winter solstice; Lat. $42^{\circ}-0'$ N. Note the large amount admitted by the south window. For the areas of these figures see Table II, page 58.

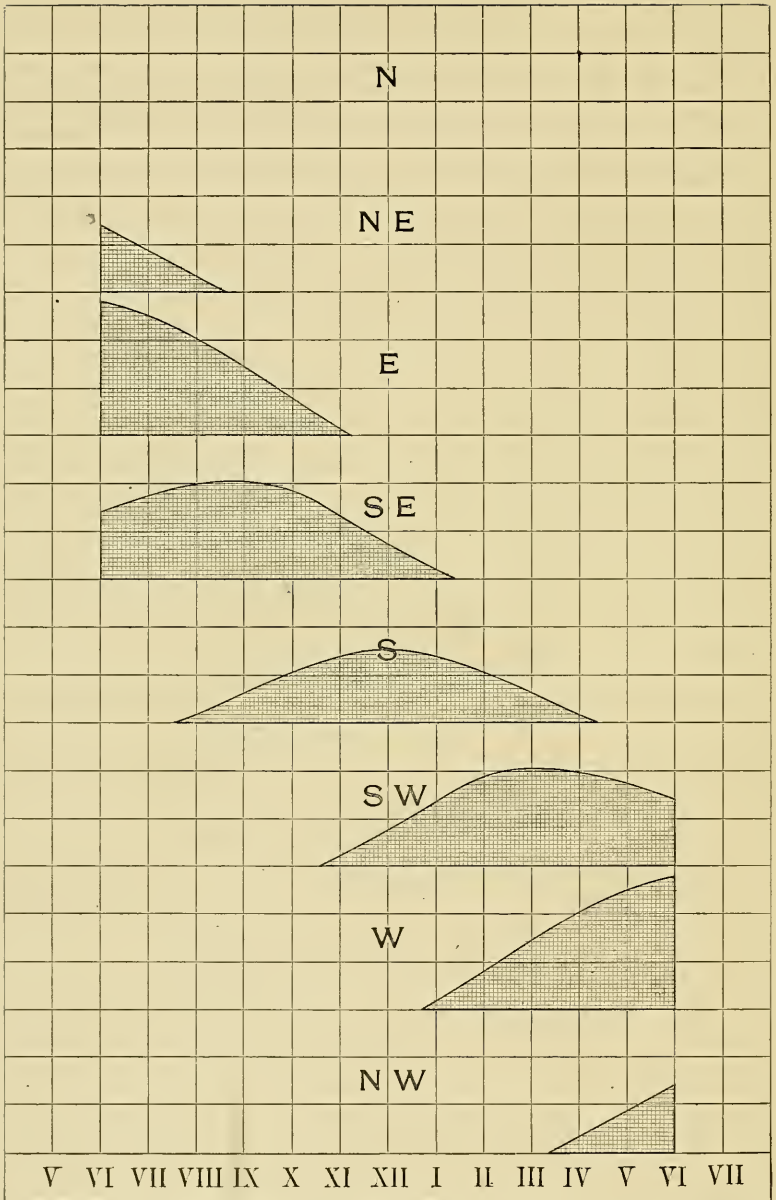

FIG. 38.—Showing the quantity and duration of direct sunlight admitted by windows of different exposures; autumnal and vernal equinox, Lat. $42^{\circ}-0'$ N. Note that the amount admitted by the south window is much less than in the preceding diagram. For the areas of these figures see Table II, page 58.

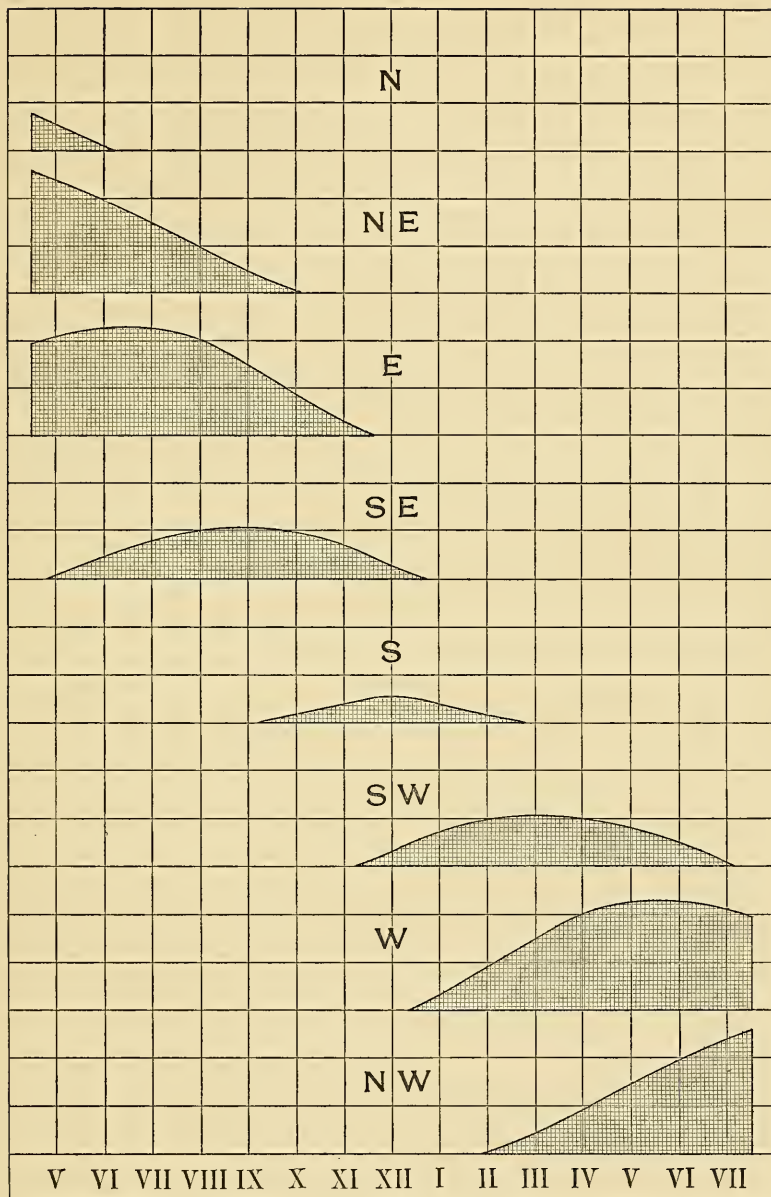

FIG. 39. — Showing the quantity and duration of direct sunlight admitted by windows of different exposures; summer solstice; Lat. $42^{\circ}-0'$ N. Note the small amount admitted by the south window. For the areas of these figures see Table II, page 58.

tions. However, an approximate value may be assigned to it.

TABLE II
TABLE OF WINDOW VALUES EXPRESSED IN "SUN HOURS"

	Winter Solstice.	Equinoxes.	Summer Solstice.
North.....	6.8
Northeast and northwest.....	18.6	73.2
East and west.....	32.9	82.7	110.7
Southeast and southwest.....	108.5	105.5	53.4
South.....	152.9	81.1	16.2

An average of twelve observations taken at the Astrophysical Observatory in Washington in 1902-3, under the direction of Mr. C. G. Abbot,¹ gives the intensity of the solar rays at the earth's surface in the afternoon, as 1.24 small calories per square centimeter per minute. Transposing this value, we obtain for the energy contained in a prism of the sun's rays one foot square in section shining for one hour (the *sun hour* of our diagrams), the equivalent of 274 British thermal units; an amount of energy, which, if it could be entirely converted into heat would be sufficient to raise one gallon of water 33° F., or 150 cubic feet of air 100° F. in temperature.

The determination of the *solar constant*, or the intensity of the solar rays in space, at the mean distance of the earth, is one of the most difficult problems in physical science, since the amount of heat absorbed by the earth's atmosphere cannot be directly measured, but must be calculated theoretically.

It may well be that the term *solar constant* is in itself an unwarranted assumption and one that has tended

¹ Smithsonian Miscellaneous Collections, Volume XLV.

to mislead the experimenter, since recent investigations appear to show that the heat emitted from the sun is not steadily uniform but fluctuates in some degree, in a manner not yet satisfactorily accounted for.

The foregoing diagrams are calculated for windows with unobstructed outlook. The effect of an obstruction will now be considered.

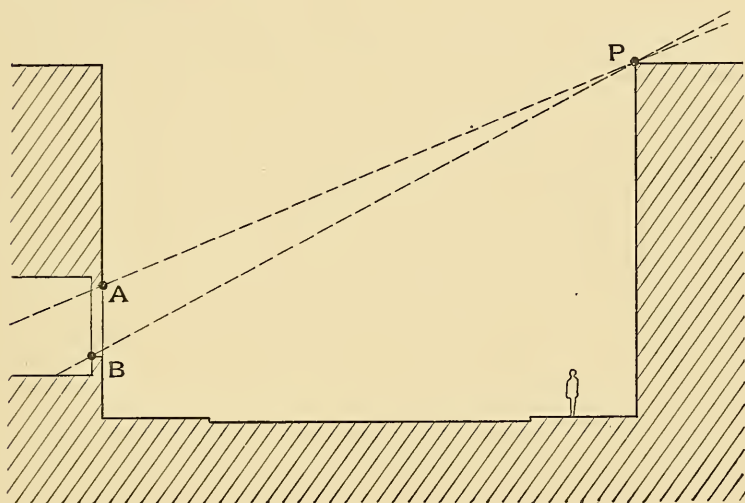

FIG. 40. — Showing the obstructed horizon of city buildings. No sunlight can come into the window until the plane of the sun's rays has reached the altitude AP .

As an example of obstructed outlook, frequent in cities and towns, we shall take the case of a lower-story window facing a row of buildings 60 feet away. We shall assume the cornice line of these buildings to be 40 feet above the ground and to extend indefinitely in both directions from the point opposite our window.

The assumed conditions are shown in Fig. 40.

It is clear that no sunlight can come into the window until the plane of the sun's rays has reached the altitude AP , but that after the altitude BP has been reached the obstruction will have no further effect.

The hour angles corresponding to these altitudes may be calculated.

Let it be required to find the time at which the sunlight will first come into a window with an east exposure, under the conditions assumed in the diagram, and at the period of the winter solstice.

The angular altitude of the obstruction above the top of the window (*i.e.* the slope of the line AP) is found by measurement to be $22^{\circ}-37'$ and the problem consists in determining the hour angle at which the plane of the sun's rays will reach this elevation.

For the purpose of representing the problem it will be convenient to use the stereographic projection (Fig. 41). The enclosing circle is the horizon; NS the meridian; P the celestial north pole; the dotted circle the path of the sun at the winter solstice, and NXS a great circle of the sphere formed by a plane intersecting the plane of the horizon on the north and south line and making an angle of $22^{\circ}-37'$ with it.

The intersection of this circle with the dotted circle (at the point X) determines the position of the sun required, and the calculation of the spherical triangle SPX gives us the hour angle (at P) which we find to be $40^{\circ}-47'$, corresponding to 9 h.-17 m. A.M. solar time.

Similarly the hour angle corresponding to the elevation BP is found to be $35^{\circ}-32'$ or 9 h.-38 m. solar time. In

other words, the effect of the obstruction is to cut off all sunlight from this window until 9 h.-17 m. A.M. and a portion of the sunlight from 9 h.-17 m. to 9 h.-38 m., after which the obstruction ceases to have any further effect.

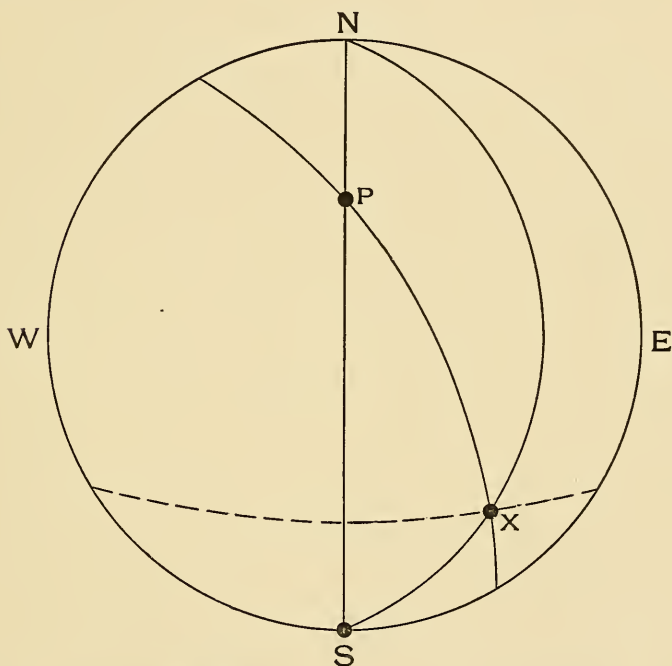

FIG. 41. — Use of the stereographic projection to represent the conditions shown in Fig. 40.

In the case of the southeast window the obstruction is complete until 10 h.-27 m. and partial until 11 h.-20 m.

In the case of the south window the obstruction is complete before 10 h.-24 m. A.M. and after 1 h.-36 m. P.M., between which hours the obstruction is partial.

For the southwest and the west windows the effects correspond to those for the southeast and east windows.

The results are shown in diagrammatic form in Fig. 42.

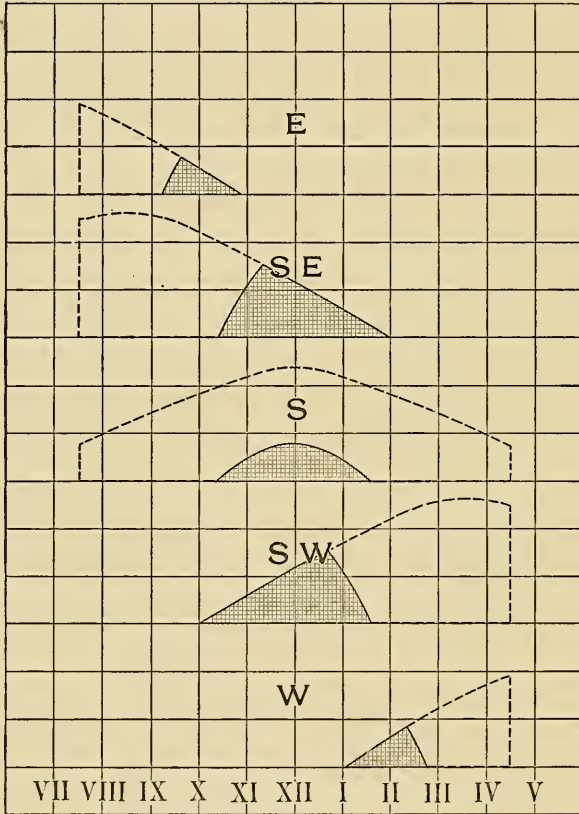

FIG. 42. — Showing the quantity and duration of direct sunlight admitted by a window with obstructed outlook, under the conditions shown in Fig. 40, for different exposures; winter solstice; Lat. $42^{\circ}-0'$ N. The full areas of the figures are identical with those of Fig. 37; the shaded portions show the quantity of sunlight admitted by the obstructed window.

It may be noted from these window diagrams, that the unobstructed south window in winter admits more sun-

light than any of the other exposures, at any period of the year, while the same window in summer admits less than any of the other exposures, except the north. The effect of obstruction, however, is serious upon the south window in winter, when sunlight is most to be desired.

The southeast and southwest windows partake to some degree of the character of the south window, in that they show a maximum in winter and a minimum in summer, although the variation is not as great as in the south window.

The east and west windows on the contrary show a maximum in summer and a minimum in winter, and are consequently less desirable exposures than the south, southeast, or southwest.

The results thus theoretically obtained may be confirmed in a striking manner with a *sun box*.

A sun box is essentially a box or chamber of non-heat-conducting material, having on one side a window or light of glass, sealed tight to prevent air leakage.

Such a box, when the window is turned toward the sun, will accumulate heat much faster than it is lost by radiation.

Fig. 43 illustrates the construction of the sun boxes employed by the author in experiments at Boxford, Massachusetts (Lat. $42^{\circ}-40'$ N.).

Two of these boxes were made, as nearly alike as possible.

They were constructed of ordinary pine boards $\frac{7}{8}$ inch thick, nailed together, without grooving or dovetailing.

The inner box (1 foot square, inside measurement)

was covered with one thickness of *lino-felt* (a non-heat-conducting material made of flax fiber quilted between two thicknesses of building paper).

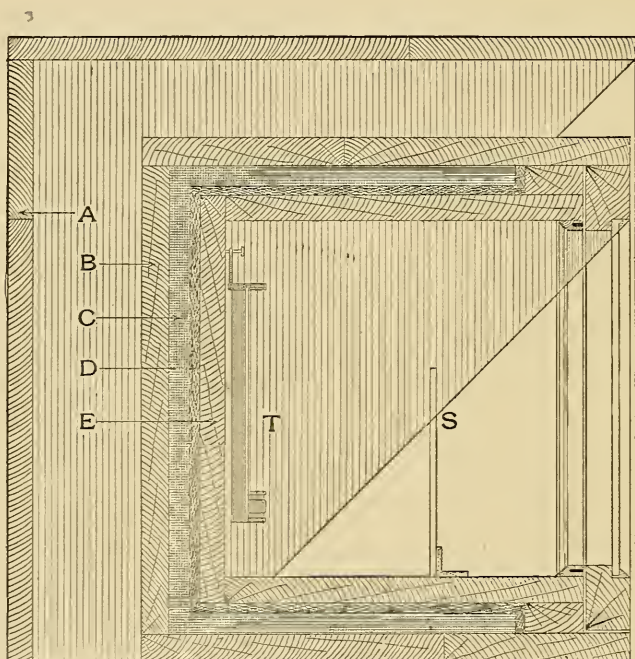

FIG. 43. — Cross-section of sun box. A. Hood or cover. B. Outer box. C. Air space. D. Lino-felt. E. Inner box. T. Thermometer. S. Shield.

The sash (glazed with $\frac{1}{4}$ -inch plate glass) was screwed into place and fitted tightly against a felt weather strip all around the edges.

The boxes were painted on the outside one coat of white paint and were shielded from the sun's direct rays, except on the window side, by wooden hoods or covers.

The temperature of the air inside the boxes was shown by a thermometer on the rear wall, in front of which was placed a wooden screen, sufficiently tall to shield the bulb from the sun's direct rays, while permitting the scale to be read from the outside.¹

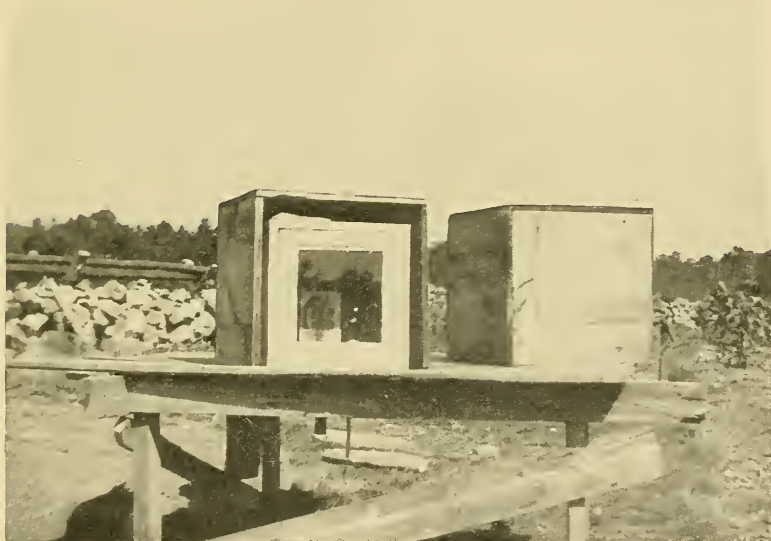

FIG. 44. — View of sun boxes.

The boxes were exposed to the sun on a platform about three feet above the ground, in an open field, with free access of sunlight from every quarter (Fig. 44). The platform was marked with a system of lines running north and south, and east and west, with diagonals in both

¹ The protecting covers and thermometer shields were omitted in the first few experiments.

directions, so that it was a simple matter to set the boxes facing in any direction desired.

In the earlier experiments the boxes were unsealed at the close of each day and allowed to remain until the temperatures were the same in each, when they were again sealed up and set for the next experiment. In the later experiments this was not done, as it was found that the temperatures became equalized by radiation during the night.

Notwithstanding the fact that the boxes were of the same shape, size, and construction, it was found that there was a difference between them, as shown by the experiments of July 14 and 15, in which both boxes were set for the same exposure and yet showed a difference of several degrees in temperature under apparently the same conditions.

For this reason the experiments do not afford an absolute basis of comparison between different exposures, such as might be obtained with apparatus more carefully made and experiments more carefully conducted.

By comparing the records for the same box, however, the relative efficiency of the same exposure at different periods of the year is shown with sufficient exactness, and follows quite closely the theoretical conclusions deduced from the diagrams.

SUN BOX RECORDS

The following is a record of experiments made with these boxes during the season of 1910. All of them (except as noted) were made on clear, bright days, with few or no clouds. All temperatures are in degrees Fahrenheit and all hours in solar time.

JUNE 26

	Time.	Air.	Box A, East.	Box B, South.
	A.M.			
1	5.48	63	72	54
2	6.36	66	80	57
3	7.08	74	100	62
4	8.	73	124	68
5	9.38	80	122	85
	P.M.			
6	12.33	85	105	110
7	1.33	85	105	112
8	2.23	85	103	108
9	3.53	85	100	104
10	6.58	72	85	85
11	7.18	70	83	83

Remarks. — No hoods on boxes. No shield for thermometers in boxes.

1. Both boxes wet with dew. Glass wet on *B*. Sun partially obscured by haze. Later on the haze wore off and it was a fine day, with flying clouds.

JUNE 29

	Time.	Air.	Box A, East.	Box B, Southeast.
	A.M.			
1	5.28	62	90	54
2	6.20	69	114	67
3	7.33	71	138	92
4	8.28	71	137	97
5	9.28	72	123	114
6	10.28	75	117	117
7	11.28	76	107	114
	P.M.			
8	1.13	77	100	103
9	3.13	77	93	95
10	4.43	77	90	91
11	6.28	78	85	86
12	9.13	52	66	65

Remarks. — No hoods on boxes. No shields for thermometers in boxes. Remarkably clear day.

1. Glass of *B* covered with dew.
2. Dew has disappeared.
5. Glass on *A* misty.
7. Glass on *A* clear.

JUNE 30

	Time.	Air.	Box A, West.	Box B, South.
	A.M.			
1	7.7	78	62	64
2	9.17	82	78	88
3	10.42	82	88	102
4	11.42	84	94	110
	P.M.			
5	1.12	84	102	112
6	2.17	86	118	110
7	3.17	84	138	104
8	4.27	84	144	100
9	5.27	80	...	98
10	6.27	72	112	88
11	6.57	67	102	85

Remarks. — No hoods on boxes. No shields for thermometers in boxes.
8. The temperature of 144° recorded in Box A is the highest which the thermometer registers.

9. Glass in A misty so that thermometer cannot be seen.

JULY 5

	Time.	Air.	Box A, South.	Box B, Northeast.
	A.M.			
1	6.06	72	47	80
2	7.06	72	54	98
3	8.11	80	70	108
4	9.11	84	82	110
5	10.11	84	99	108
6	11.41	84	110	106
	P.M.			
7	12.41	86	116	106
8	1.41	87	117	104
9	2.26	88	116	102
10	4.11	86	106	100
11	5.11	86	102	96
12	7.51	64	84	82

Remarks. — No hoods on boxes. Clear day.

1. Glass of A covered with dew.

JULY 7

	Time.	Air.	Box A, South.	Box B, East.
	A.M.			
1	6.11	55	48	85
2	7.00	63	55	108
3	7.31	68	60	115
4	9.36	82	84	132
5	10.41	86	96	122
6	11.41	86	106	112
	P.M.			
7	12.41	88	112	106
8	1.26	90	112	102
9	3.01	88	108	98
10	3.51	84	100	94
11	4.46	98	98	96
12	5.41	92	94	92

Remarks. — No hoods on boxes. Perfectly clear day.

11. Air thermometer in direct sunlight.

12. Air thermometer in direct sunlight.

JULY 10

	Time.	Air.	Box A, South.	Box B, East.
	A.M.			
1	5.36	62	62	68
2	7.51	80	72	110
3	8.26	84	77	117
4	9.26	91	87	124
5	10.26	96	99	124
6	11.41	100	110	118
	P.M.			
7	12.41	102	116	114
8	1.06	100	117	112
9	1.51	100	118	109
10	2.41	95	114	106
11	3.41	94	110	104
12	4.51	91	105	100

Remarks: —

1. Slight haze: humidity high.

7. Floating clouds.

8. Floating clouds.

9. Thunder clouds.

12. Clear: good breeze.

JULY 14

	Time.	Air.	Box A, East.	Box B, East.
	A.M.			
1	6.10	61	98	100
2	6.50	71	118	121
3	7.40	74	126	131
4	8.10	78	132	136
5	9.10	80	136	138
6	10.10	88	138	138

Remarks. — Clear day. Boxes placed side by side, *B* being to the north of *A*.

JULY 15

Time.	Air.	Box A, East.	Box B, East.
A.M.			
6.55	68	102	102
7.35	70	115	117
8.10	76	124	126
9.10	80	132	130
10.10	82	128	128

Remarks. — Somewhat cloudy in early morning; clear later. Boxes placed side by side, *A* being to the north of *B*.

JULY 20

Time.	Air.	Box A, East.	Box B, Southeast.
A.M.			
5.	50	60	52
6.40	59	105	76
7.05	62	114	84
7.35	65	120	94
7.55	68	126	102
8.25	70	122	104
8.55	76	118	106
9.25	76	118	108
9.55	78	120	110
10.25	78	110	112
11.10	76	106	110
11.55	78	102	108
P.M.			
12.25	78	96	100
2.25	78	86	86
3.55	78	82	82

Remarks. — Clear day.

JULY 21

	Time.	Air.	Box A, Southeast.	Box B, East.
	A.M.			
1	5.	56	54	56
2	6.40	64	74	96
3	7.05	66	82	105
4	7.35	68	91	116
5	8.	72	98	129
6	9.	76	110	128
7	10.45	86	120	118
8	11.45	90	118	112
	P.M.			
9	12.35	94	112	108
10	2.15	90	102	102
11	3.30	86	98	98
12	5.20	80	90	90

Remarks:

1. Sun rising through cloud bank.
3. Perfectly clear.

JULY 24

Time.	Air.	Box A, Southwest.	Box B, Southeast.
A.M.			
8.04	78	67	86
8.44	84	72	98
9.34	88	78	108
10.19	90	85	116
10.54	94	92	118
11.54	99	104	120
P.M.			
1.39	98	111	112
2.49	96	114	107
4.39	94	122	102
5.	94	121	101
5.24	92	116	100

Remarks. — Somewhat cloudy day.

AUGUST 7

	Time.	Air.	Box A, South,	Box B, East.
	A.M.			
1	7.45	68	61	121
2	8.35	72	68	130
3	9.	71	73	130
4	9.35	76	81	129
	P.M.			
5	12.10	81	105	108
6	1.45	83	104	102
7	4.40	77	96	90
8	6.35	68	84	80

Remarks:

3. Sun behind thin clouds.
6. Sun behind clouds.

AUGUST 21

Time.	Air.	Box A, West.	Box B, Southeast.
A.M.			
8.28	72	56	104
9.13	75	60	114
10.13	80	67	123
11.08	80	72	125
P.M.			
1.13	81	88	110
1.53	79	97	104
2.08	76	118	94
3.33	76	123	91
4.13	76	132	...
6.48	67	103	76

Remarks. — Clear day.

AUGUST 28

	Time.	Air.	Box A, South.	Box B, Southeast.
	A.M.			
1	7.14	65	46	76
2	8.29	70	61	102
3	8.59	72	68	110
4	9.29	74	77	116
5	11.14	78	114	123
6	11.50	78	112	119
	P.M.			
7	12.20	80	117	118
8	12.40	80	117	114
9	1.50	82	120	107
10	2.30	83	118	103
11	5.	70	95	86
12	7.14	63	75	72

Remarks:

6. Slightly cloudy.
 7. Clear again.
 8. Slightly cloudy.
 9. Slightly cloudy.
 10. Clear.

SEPTEMBER 18

Time.	Air.	Box A, South.	Box B, East.
A.M.			
6.31	47	44	57
7.40	60	51	97
8.46	68	68	112
9.11	69	75	114
9.36	72	85	114
10.51	76	104	106
11.26	77	113	102
P.M.			
12.51	82	127	95
2.16	81	127	93
3.06	82	122	92
4.16	80	110	89
5.06	76	100	85
7.16	70	82	76

Remarks. — Clear day.

OCTOBER 24

Time.	Air.	Box A, South.	Box B, East.
A.M.			
6.19	32	32	32
7.	36	33	45
7.46	39	42	70
8.11	41	50	80
8.31	42	58	87
9.04	44	70	92
9.31	45	79	93
10.46	50	101	85
11.51	52	116	74
P.M.			
12.11	55	119	72
1.11	57	123	68
1.38	58	125	67
1.55	59	125	67
2.11	59	124	66
3.03	58	107	64
4.41	53	84	60
6.31	46	63	52

Remarks. — Remarkably clear day.

DECEMBER 22

	Time.	Air.	Box A, South.	Box B, East.
	A.M.			
1	9.47	16	56	45
2	10.57	20	88	46
	P.M.			
3	12.52	24	114	38
4	1.42	25	115	44
5	3.22	24	94	33

Remarks. — Clear day.

4. The reading in Box B is probably an error.

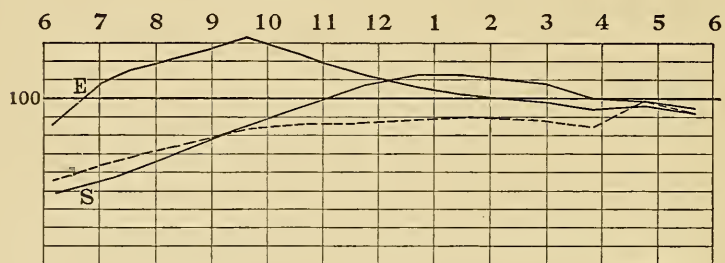

JUL. 7

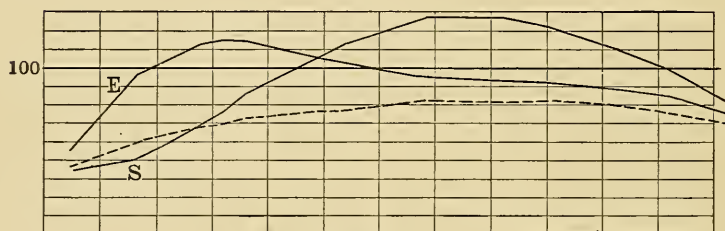

SEP. 18

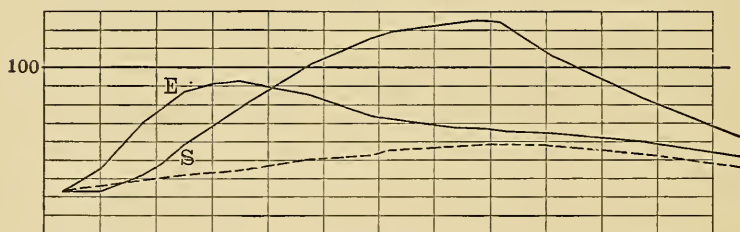

OCT. 24

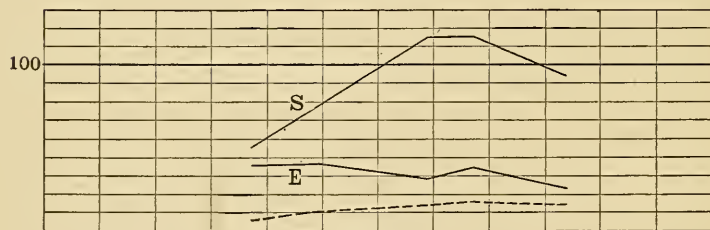

DEC. 22

FIG. 45.—Sun-box records for south and east exposures. The dotted lines show the temperature of the air; the full lines the temperatures within the boxes. The figures at the top denote the hours of the day. The divisions of the vertical scale are equal to ten degrees of temperature.

The records of July 7, September 18, October 24, and December 22 are shown graphically in Fig. 45 the temperature being plotted in the form of curves; the dotted curve showing the temperature of the air outside and the solid curves that of the air within the boxes.

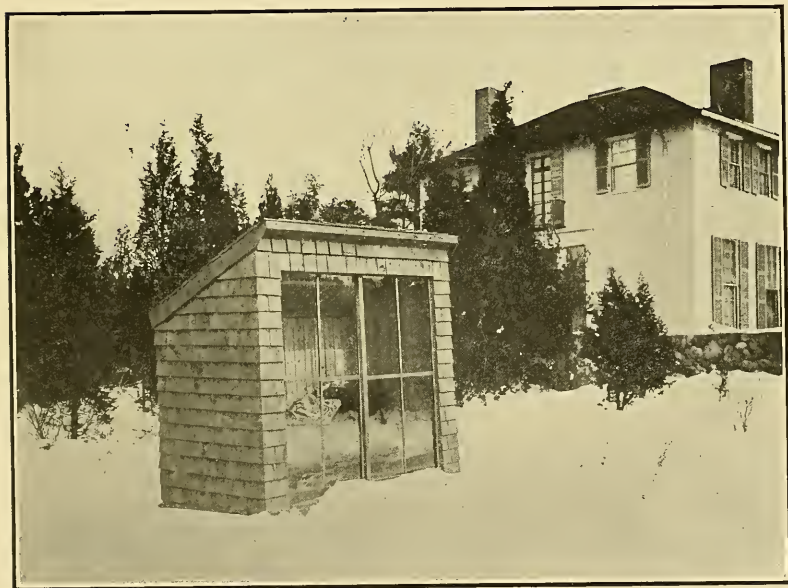

FIG. 46. — Mr. Cabot's sun house.

Each horizontal division of the scale corresponds to one hour of time and each vertical division to 10° of temperature.

The boxes occupied the same relative position in all four experiments, so that the records show very well the change in efficiency of the same exposure with the change of seasons.

That the sun's rays are not of indifferent value in the heating of our houses in winter is shown by the last experiment (December 22), in which the air within the sun box reached a temperature of 115° F. with the air outside at 25° F.

Every dwelling may be converted into a *sun box* by properly insulating the outside walls. Fig. 46 is reproduced from a photograph of a "sun house" built by the late Mr. Samuel Cabot, on his place at Canton, Massachusetts. This little building faces the south, on a southerly slope, and is quite shallow in proportion to its breadth.

The walls and roof are thoroughly insulated.

A temperature of 100° F. and over has been frequently attained within this building with an outside temperature of zero or lower, entirely from the warmth of the sun's rays.

The foregoing study of windows has an important bearing on the orientation of hospital buildings, and in the next chapter we shall take up the question of hospitals in some detail.

CHAPTER III

HOSPITALS

THE typical hospital ward is a long, narrow room, with windows on both sides, between the beds. In the *open-ended* type of ward there are windows also at one end, and these are of great value, especially in winter, as will presently be shown.

A typical ward pavilion of the open-ended type is shown in Fig. 47.

There is a difference of opinion as to the best orientation for ward pavilions.

In a description of the Heidelberg University Hospital, given in Mouatt & Snell's *Hospital Construction and Management*, it is stated that "The question of the aspect of the windows of the wards was only settled after very great deliberation by the authorities charged with the erection of this building, and Dr. Knauff gives in his work¹ a very exhaustive account of the considerations which ultimately led to the determination of the placing of the axes of the various pavilions as nearly east and west as the shape of the ground would permit. Actually their direction is about E. S. E. and W. N. W. It is remarkable that the Friedrichshain building authorities, as the result of their deliberations on this question, arrived at an exactly opposite conclusion, and placed the axes of their pavilions directly north and south."

¹ Das Neue Academische Krankenhaus in Heidelberg, München, 1879.

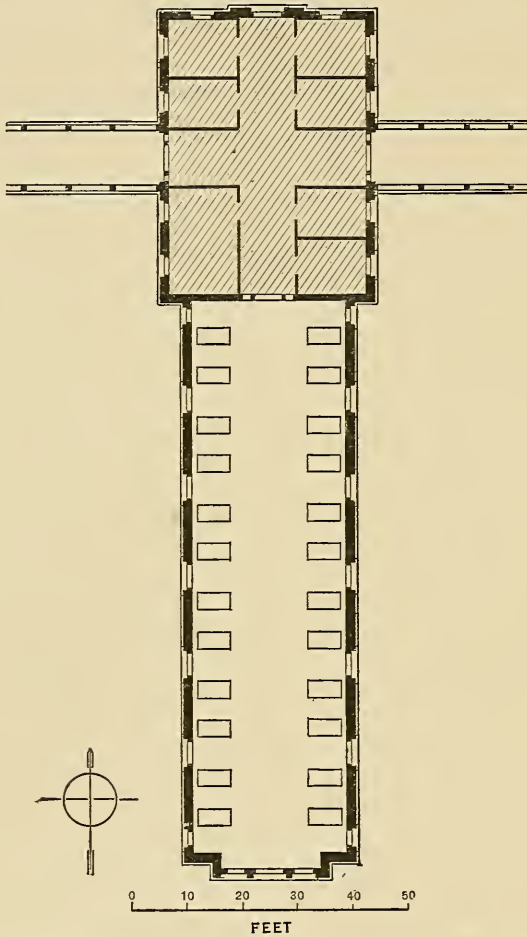

FIG. 47. — Typical one story ward pavilion of twenty-four beds. This plan is not given as an example to be followed, but to illustrate several common faults.

The orientation is bad, giving the minimum of sunlight in winter and the maximum in summer. The arrangement of the windows, one for each two beds, is not as good as one for each bed. The ward itself has excessive length in proportion to its width, giving an unpleasing effect to the interior, and the distance to be traversed by the nurses, in going to and from the service rooms, is excessive.

A good feature of the plan is the large bay window at the south end; if it were not for this the ward would have very little sunlight in winter. The building would be improved by making the service portion (shaded), two stories in height, after the manner of the Virchow ward unit. (See Fig. 56.)

In the *Handbook for Hospitals* [No. 32 of the publications of the State Charities Aid Association of New York (N.Y., 1883)], it is recommended that the long axes of the wards should run as nearly as possible from northeast to southwest.

The majority of those, however, who have written on hospital construction incline to a north and south direction.

This is the orientation recommended by Sir Douglas Galton (*Healthy Hospitals, Oxford, 1893*):

“The arrangement by which sunshine will always fall to the largest extent on the space between pavilions, and also be distributed most evenly upon the wall surface, is obtained in this country (England) by placing the pavilions on a north and south line or axis, because the slanting rays of the sun fall in the morning on the eastern and in the evening on the western side.”

There is also a wide variation in practice.

In a list of thirty-eight hospitals given in Mouatt & Snell's work, there are thirteen in which the pavilions are placed approximately north and south; fifteen in which they are placed approximately east and west; six in which they are placed approximately northwest and southeast, and four in which they are placed approximately northeast and southwest.

Let us examine the questions in the light of what we have already learned about windows.

For an example we shall take a ward with unobstructed outlook, having ten of our typical windows (3 ft.-6 in. by 8 ft.-0. in.) on each side and none at the ends.

Using the factors in Table II, giving the quantity of sunlight, in "sun hours," admitted by windows of different exposures, we obtain the following results:

TABLE III

Axis.	Winter Solstice.	Equinoxes.	Summer Solstice.
North and south.....	658	1652	2214
Northeast and southwest.....	1085	1241	1266
Northwest and southeast.....	1085	1241	1266
East and west.....	1529	811	230

By adding three windows at the end of the ward the results are somewhat modified, as shown in the following table:

TABLE IV

Axis.	Winter Solstice.	Equinoxes.	Summer Solstice.
North and south.....	1116.7	1895.8	2262.6
Northeast and southwest.....	1410.5	1557.5	1426.2
Northwest and southeast.....	1410.5	1557.5	1426.2
East and west.....	1627.7	1058.8	562.1

In both cases, the ward placed with its axis north and south receives the least sunlight in winter, when sunlight is most needed, and the maximum in summer, when it is least to be desired.

In the east-and-west position the results are reversed, showing a maximum in winter and a minimum in summer.

If we were to base our judgment wholly on the amount of sunlight received by windows, we should be led to follow the conclusion of Dr. Knauff, that the best position for such a building is with its long axis placed east and west.

There are two disadvantages, however, in the east-and-west position; the first that it involves an *area of complete shadow*, on the north side of the building, during one-half the year, and the second that in this position a greater distance is necessary between the pavilions than in any of the other positions considered.

The north-and-south position has all of the disadvantages of the east-and-west position and none of the advantages. The windows admit little sunlight in winter and an excessive quantity in summer. If conditions make it necessary to adopt this orientation, the wards should always have windows at the south end.

There remain to be considered the two intermediate positions, northeast-southwest and northwest-southeast.

In both of these there is little variation in the amount of sunlight received at different seasons, and by placing windows at the southeast or southwest end, as the case may be, the amount of sunlight in winter is very much increased.

Furthermore, the buildings may be placed closer together than in either of the other two positions, and may be so planned that all of the outside walls are exposed to the sun at some portion of the day throughout the year; and this advantage is obtained not only for the wards, but also for the other buildings of the hospital group, which is not possible where a north-and-south, east-and-west system of axes is adopted.

As between the northeast-southwest and the northwest-southeast positions, the only difference is that in the former the broad side of the buildings is exposed to the sunlight

in the forenoon, while in the latter the reverse effect is obtained. This indicates a slight advantage for the former, since the forenoon sunlight is more generally prized than the afternoon sunlight, probably because it is constantly increasing in amount, while in the afternoon it is constantly decreasing.

We are, therefore, led to recommend that for hospital buildings in or near the latitude considered in this book, the long axis of the wards should be placed as nearly northeast and southwest as possible, and, furthermore, that the southwest ends of the pavilions should always have windows.

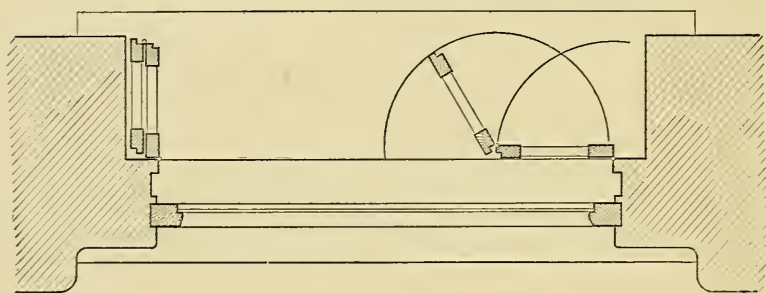

FIG. 48. — Illustrating the French method of arranging outside blinds, so as to fold back against the jamb. This is the ideal arrangement for a hospital building.

The ward windows should always be provided with blinds, shutters, or shades.

Outside blinds, folding back against the jamb, are protected from the wind and weather, and are easily reached from the inside. With a window of 3 ft.-6 in. opening, which goes well with a lineal bed space of 8 ft.-0 in., a reveal of ten inches affords the requisite space for outside blinds of this type. A detail of the arrangement is shown in Fig. 48.

This method of hanging blinds is customary in France and deserves to be more generally used. It is better than the American method, in which the blinds open back against the outside wall, where they rattle in the wind, are exposed to the sun and rain, and are, moreover, exceedingly troublesome to operate.

The ward pavilion is the unit of hospital construction, and the essential problem in planning a hospital is in the design and grouping of these units.

The typical ward unit is a one-story building, although there are many examples of hospitals built on the pavilion plan in which the pavilions are two, and even three stories in height.

There is an economy of construction in the superposition of stories, and although the buildings require to be placed at a greater distance apart to secure adequate sunlight, there is, notwithstanding, an economy of land as well.

This is illustrated in Fig. 49 in the upper part of which are shown, in section, four one-story pavilions, spaced at a distance apart equal to one and one-half times their height. In the lower part of the same diagram are shown two pavilions of two stories each, also at a distance apart equal to one and a half times their height.

The number of patients accommodated is the same in both arrangements, but the amount of land required for the two-story pavilions, although the distance between them is greater, is less than for the one-story pavilions.

If we consider not only the cross section, but also the plan, a further economy will appear in favor of the two-

story arrangement; for, the length of the buildings remaining the same in both cases, an increase of distance between them reduces the proportional depth of the *U* court between the buildings, making it more open to the sun. It follows, therefore, that the distance between pavilions should be governed, in part at least, by their relative length, as well as their relative height, and it may, therefore, be justifiable to place two-story pavilions at a less distance apart in proportion to their height, than one-story pavilions of the same length.

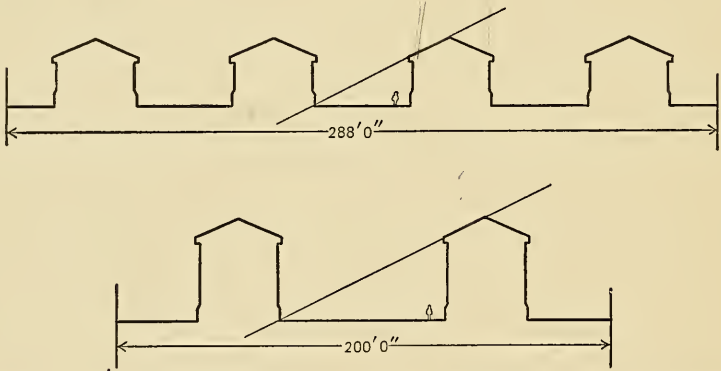

FIG. 49. — Illustrating the economy of land in the two-story type of hospital building.

While economy is of importance in hospital construction, it must always be kept subordinate to the welfare of the patient, for that is the whole end and aim of the hospital.

“L’hôpital en effet n’a qu’un seul but: chercher à guérir, et tout doit y concourir. . . . Et ici plus que partout ailleurs, l’économie est sacrée, car si pour la même somme on peut assurer quelques lits de plus, c’est de l’impuissance

finale de l'assistance publique diminuée d'autant: Mais l'économie ne doit être cherchée au detriment de l'hygiène: une économie sur l'ornementation d'une façade est un vertu: une économie sur le cube d'air des malades serait un crime. L'hôpital est fait pour le malade, voilà ce qu'il ne faut jamais perdre de vue."¹

In all respects is the one-story pavilion the best for the patient, but especially because it is best adapted to ventilation by natural means.

"The amount of fresh air renewed by natural ventilation is infinitely greater than that which can be obtained by the most costly mechanical contrivances. Thus, in a room of the capacity of 1500 cubic meters (nearly 53,000 cubic feet) the air can be renewed by the opening of a single window in less than half an hour, with a velocity equal to 0.50 m., or nearly two feet, in every second." (M. Tollet, quoted in Mouatt & Snell's *Hospital Construction and Management*.)

Artificial or forced ventilation, which in our climate is a necessary evil during a large part of the year, may be successfully adapted to a building of superposed stories, as well as to a subway or a mine. But for ventilation by natural means nothing has ever been designed so effective as ridge or monitor ventilation (Fig. 50), in conjunction with open windows, a method of construction which is, of course, not possible where one ward is superposed upon another, except for the uppermost story.

Several types of ward pavilions are shown in Fig. 51. Nos. 1 and 2 are single pavilions of the *open-ended* type;

¹ *Éléments et Théorie de L'Architecture*. J. Gaudet, Paris.

No. 3 a double pavilion, and No. 4 a single pavilion, both with closed ends.

Nos. 1 and 2 differ only in the position of the corridor, which, in No. 1 runs through the service portion of the pavilion;¹ and in No. 2 is placed clear of the building.

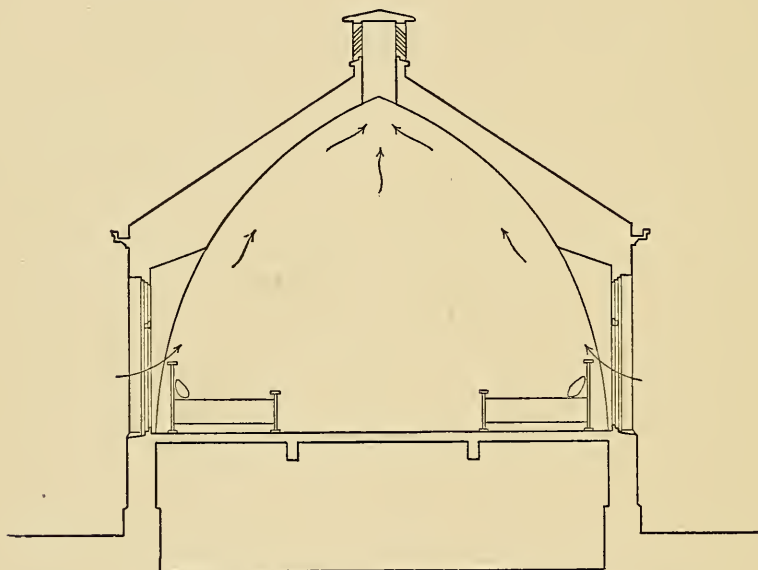
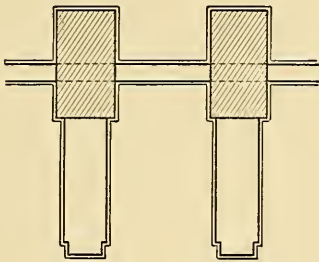

FIG. 50. — Illustrating the method of ridge ventilation for hospital ward pavilions.

This is a cross section of the one-story wings of the plan shown in Fig. 58. (The arched form is advantageous, but is not essential.)

The advantage of the latter arrangement is that any pavilion of a group may be reached without passing through any of the others, and the circulation through the corridor is unimpeded by doors.

¹ In all the figures the service portion is indicated by shading.



1

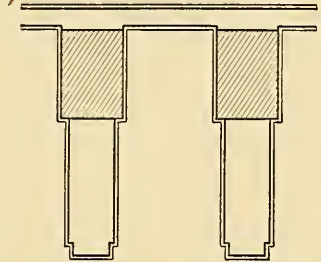

2

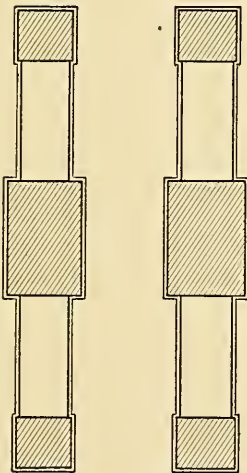

3



4

FIG. 51. — Illustrating several types of ward pavilions.

Furthermore, when a series of pavilions of the type of No. 1 are connected together, a series of *U* courts is created, facing in opposite directions, involving an *area of complete shadow* in one or the other.

No. 2 is free from this objection.

No. 3 is the type of pavilion adopted in the Virchow Hospital in Berlin.¹ It consists of two one-story wards joined by a central service portion two stories in height, in the upper part of which are lodged the nurses who have charge of the pavilion.

This type of pavilion was not designed, and is not suitable for, corridor connection and is therefore not likely to be adopted in our climate, where it is considered essential that the pavilions should be connected by corridors.

In both Nos. 3 and 4 the ends of the wards are blocked by service rooms and in No. 4 (Friedrichshain) these service rooms project so far as to cut off both air and sunlight from the ward.

Pavilions may be grouped in various ways.

Fig. 52 is typical of the arrangement adopted at the Virchow Hospital. It will be noted that the individual pavilions are placed quite close together and yet have access to large open spaces on either side.

There seems to be no good reason why the pavilions of a general hospital should be placed any farther apart than is necessary to secure adequate sunlight and a free passage of air between them. Compactness saves steps and helps toward economy of administration. Furthermore, too great a space between pavilions is a

¹ Opened in 1906. Architect, Dr. Ludwig Hoffmann.

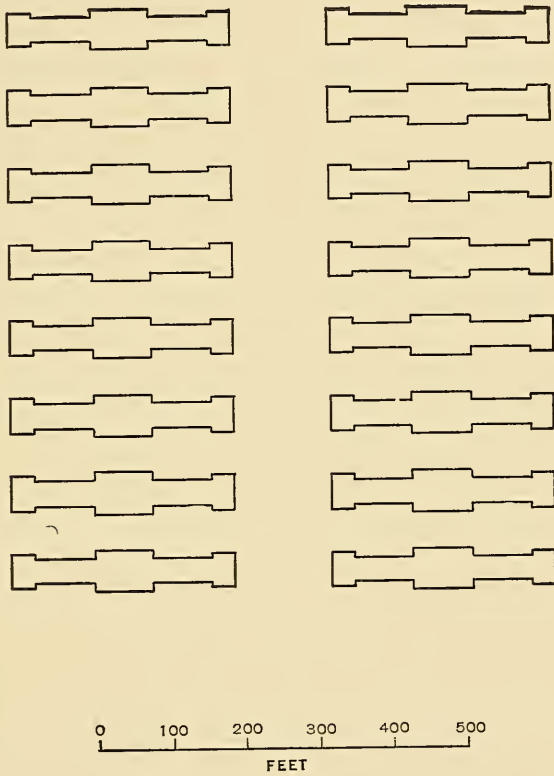
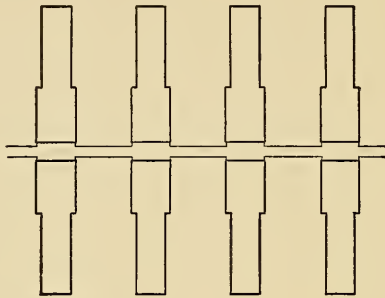
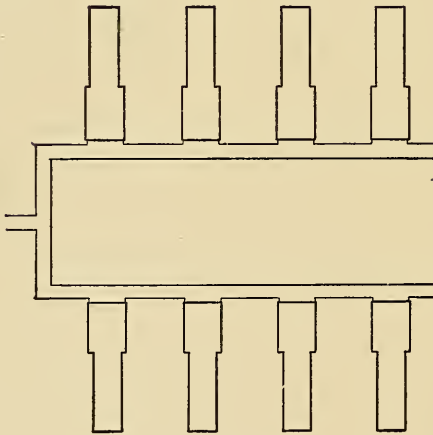

FIG. 52. — Arrangement of ward pavilions, Virchow Hospital.

In the entire hospital there are twenty of these pavilions, besides others of a different type.



1



2



FIG. 53. — Two common methods of grouping ward pavilions. Neither one is recommended.

temptation to future boards of trustees, under the demands for increased accommodation, to fill up these spaces with new buildings.

Fig. 53 illustrates two dispositions, both of which are symmetrical in the narrow sense of the word, and both of which are bad, since they involve *U* courts facing in opposite

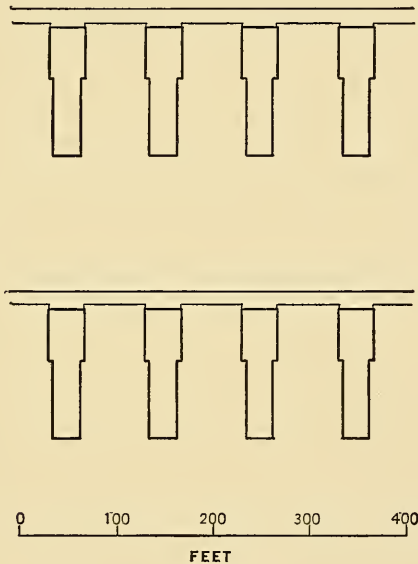

FIG. 54 — A good method of grouping ward pavilions.

directions, and a disparity in the amount of sunlight received by the opposite wards.

The arrangement shown in Fig. 54 is more truly symmetrical, since all of the wards present the same exposure to the sun, and it is recommended as the best arrangement for single pavilions of the *open-end* type.

Fig. 55 shows a good arrangement of buildings where the size of the lot does not allow of the double corridor plan.

The axes of the buildings are placed very nearly northeast and southwest and the shadows are shown for noon, at the period of the equinoxes.

In the conventional rendering of architectural drawings the shadows are cast as if the sun's rays came from the left, at an angle of 45° with the plane of the picture, both in plan and elevation.

This convention is assumed irrespective of the position which the building is to occupy, and all the elevations of a building are treated as if they faced in the same direction. A façade, for instance, having a northerly exposure, will be represented with shadows such as could only occur on a south façade, and an impression of abundant sunlight is given which is not only inaccurate, but false and misleading.

Such a departure from accuracy and truth is harmful in its effect upon the student and a careless habit is engendered of regarding the architectural drawing as an end in itself, while actual conditions of site, surroundings and exposure are lost sight of. So, too, has grown up the practice of studying an architectural plan irrespective of its orientation. So little is this matter regarded that it is the exception, rather than the rule, to find the points of the compass marked upon an architectural plan.

The study of shades and shadows is regarded so entirely for its use in the conventional rendering of the elevation that it is seldom applied to the rendering of the plan, although it is here that its greatest usefulness is found, especially in the study of groups of buildings, or for the representation of landscape work. In no other way may the relative heights of buildings, or changes in level of a site, be so graphically shown in a single drawing.

The types of pavilion so far illustrated are not well adapted to the requirements of modern medical treatment. The classification of patients according to their needs cannot be accomplished in a building containing but one large, open ward with one or two single rooms; and the open-air treatment, which has been found so effectual in many medical cases, cannot well be given except in a building especially designed for that purpose.

The program has changed and a new type of hospital construction must be devised to meet it.

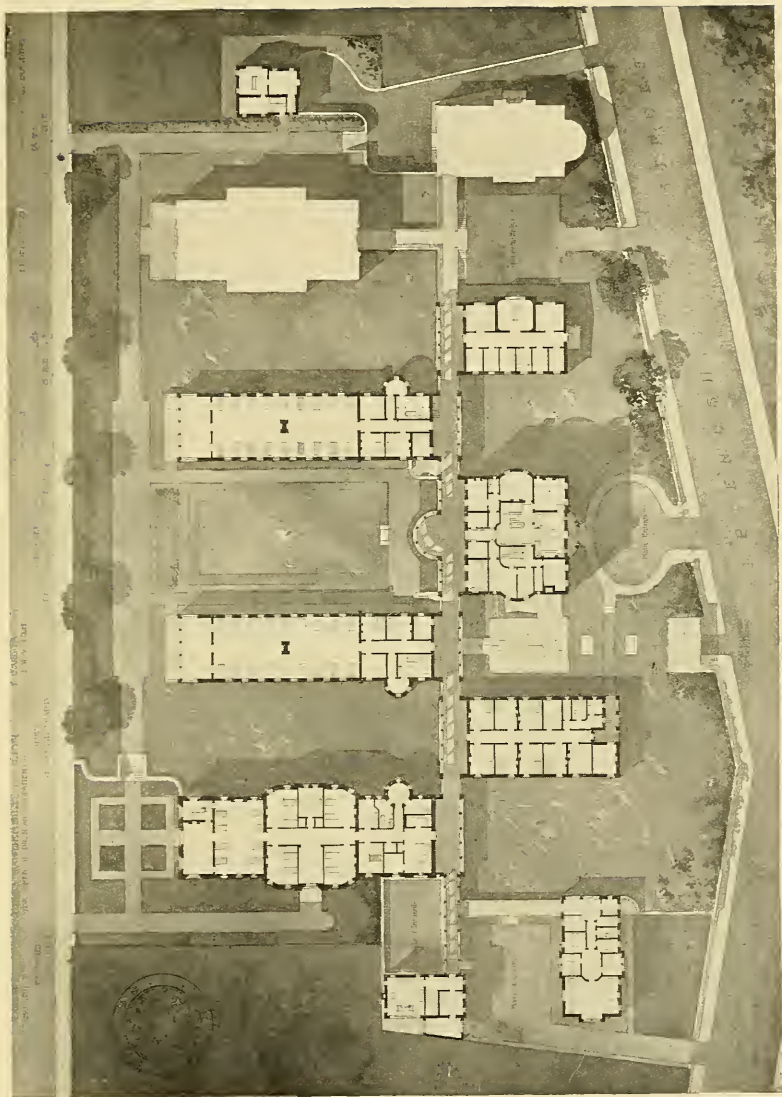

FIG. 55. — Ground plan of the Newport Hospital. William Atkinson, architect.

The requirements for a modern system of hospital construction adapted to a general hospital of moderate size may be stated as follows:

The pavilions should be placed no farther apart (except for contagious cases) than is necessary to secure adequate sunlight and air.

Adjacent to the pavilions, but not between them, should be large, open areas easily accessible to the patients. (An admirable example of such an open space is the famous *Mittel Allee* of the Virchow Hospital.)

Each pavilion should provide for a subdivision of the patients within itself and should, therefore, contain at least two or more open wards of moderate size, besides a number of smaller wards and single rooms.

All of the open wards should have ridge or monitor ventilation, and therefore one ward may not be superposed upon another.

Ample facilities should be provided for open-air treatment, and these facilities should be of two kinds: open terraces or balconies opening directly from the wards, for open-air treatment in the daytime; and roofed balconies or loggias, which may be screened in and protected with blinds, affording an opportunity for patients to sleep in the open air.

Each pavilion should have a day room, for those patients who are able to be out of bed; and the bathrooms, lavatories, and other service rooms should be ample in number and in size.

The working out of such a program will naturally result in a building having more the aspect of a large,

private house, than the long, narrow buildings which we have been accustomed to associate with hospital architecture.

The ward unit about to be described has been designed to fulfill this program. It is an attempt to adapt what may be called the "Virchow idea" to the conditions with which the American architect is called upon to deal, of which the two dominant ones are the covered corridors between the buildings required by our climate and the compactness in plan required by the custom of build-



FIG. 56. — Elevation of the Virchow unit. Each of these units is virtually a complete hospital in itself, the central pavilion corresponding to the administration building of a cottage hospital. Each unit provides for forty-six beds, as follows:

Two open wards of twenty beds each; two separation rooms of two beds each; two separation rooms, one bed each.

ing hospitals in or close to the large cities, where the cost of land usually makes an extended pavilion plan impracticable.

It has been noted that in the Virchow unit the central portion, containing the service rooms, is two stories high. The total height of this central portion is not, however, much greater than that of the wings, since the service rooms are not as high as the wards (Fig. 56).

The principle involved in this arrangement may be extended further (Fig. 57), resulting in what may be called the *pyramidal type* of ward construction, in which each story is less in area than the one below. Such buildings may be placed close together and yet have adequate sunlight, and all of the wards may have ridge ventilation.

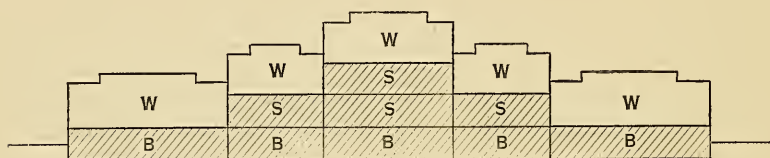

FIG. 57.—Diagrammatic section illustrating the "pyramidal" type of ward. The service portion is indicated by the letter S, and the wards proper by the letter W. B indicates the basement. It will be noted that all the wards can have ridge ventilation. The idea expressed by this diagram is worked out in practical form in the plan on the opposite page, in which the one story wings have been turned at right angles to the main structure, forming a U court.

The diagrams and plans herein presented illustrate a ward unit of a pyramidal type designed by the author. Figs. 58, 59, and 60 give the detailed plans of each floor, and the diagrams of Figs. 61, 62, and 63 show the building in isometric projection, with the shadows as they would be at the winter solstice.

The general plan (Fig. 64) illustrates a method of grouping these units to form a complete hospital.

The basic idea of the pyramidal type of ward is to combine the economic advantages of the three-story building, and its adaptability to subdivision of patients, while retaining the most valuable feature of the one-story type, namely, ridge ventilation.

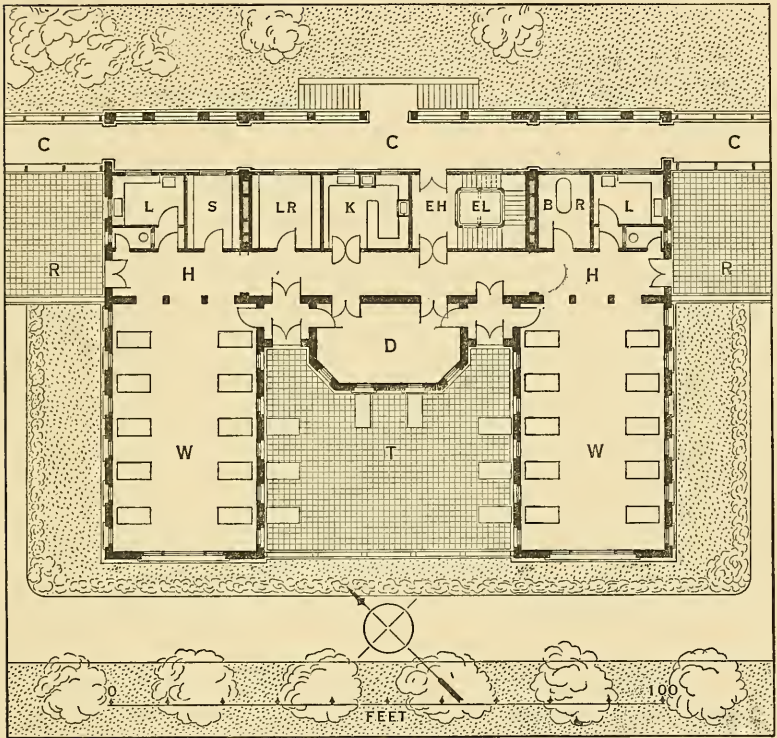

FIG. 58. — Pyramidal type of ward unit. First-floor plan. A cross section of the one-story ward wings (W) is shown in Fig. 50. These wings are higher studded than the service portion.

REFERENCES.

C. Connecting corridors. L. Lavatories, $9'-0'' \times 13'-0''$. S. Laboratory, $9'-9'' \times 12'-0''$. L. R. Linen room, $12'-0'' \times 12'-6''$. K. Kitchen, $12'-0'' \times 15'-6''$. E. H. Entrance hall. EL. Elevator. B. R. Bath room, $9'-9'' \times 12'-0''$. H. Hall. D. Day room, $14'-6'' \times 25'-6''$. W. Wards, $26'-0'' \times 45'-0''$. T. Open-air terrace. R. Terraces between the pavilions.

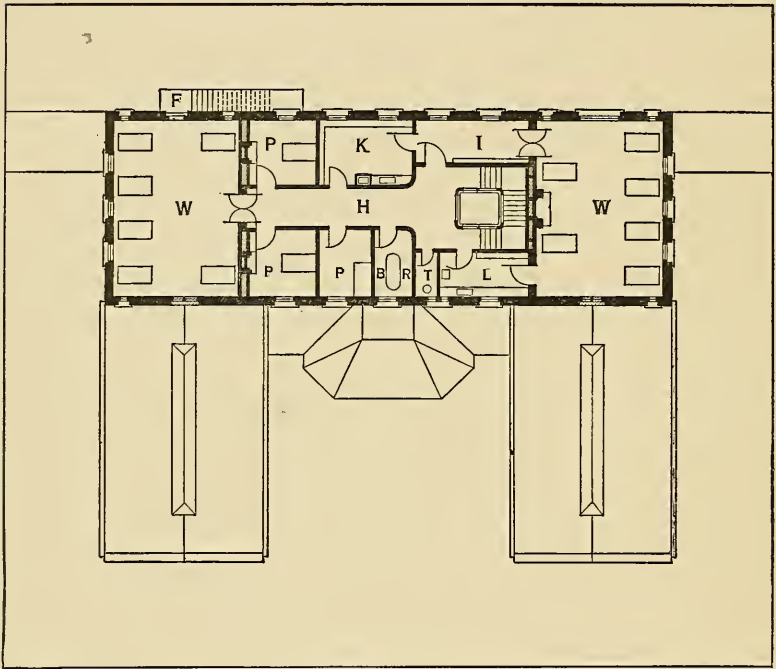

FIG. 59. — Pyramidal type of ward unit. Second-floor plan. The wards (W) have ridge ventilation. They are higher studded than the service portion.

REFERENCES.

W. Wards, 22'-9" × 32'-0". P. Private rooms, 11'-9" × 12'-0" and 9'-6" × 12'-0". K. Kitchen, 12'-0" × 16'-9". I. Linen room, 8'-0" × 20'-6". B. R. Bath room, 7'-0" × 12'-0". T. Patient's toilet room, 4'-0" × 8'-0". L. Lavatory, 8'-0" × 15'-6". H. Hall. F. Fire escape stairway.

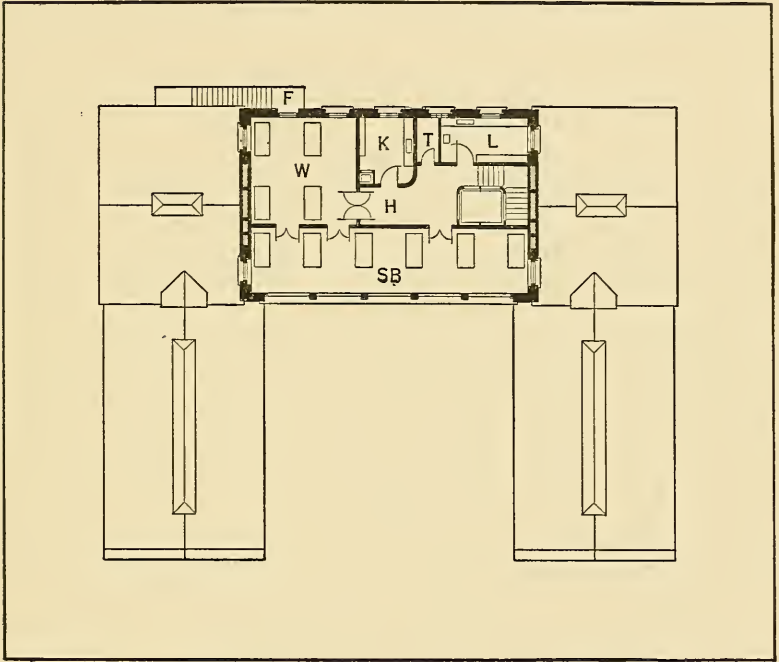

FIG. 60.—Pyramidal type of ward unit. Third-floor plan. The ward (W) has ridge ventilation and extends up to the roof, as does also the open-air ward, S. B.

REFERENCES.

W. Ward, 19'-0" × 19'-0". K. Kitchen, 10'-0" × 11'-9". T. Patient's toilet room, 4'-0" × 8'-0". L. Linen room, 8'-0" × 15'-6". H. Hall. S. B. Open-air ward. F. Fire escape stairway.

The height from floor to ceiling of an open ward should never be less than twelve feet and is often made more than this, and in wards of the type shown in Fig. 50 it is necessarily much greater. Assuming thirteen feet in the

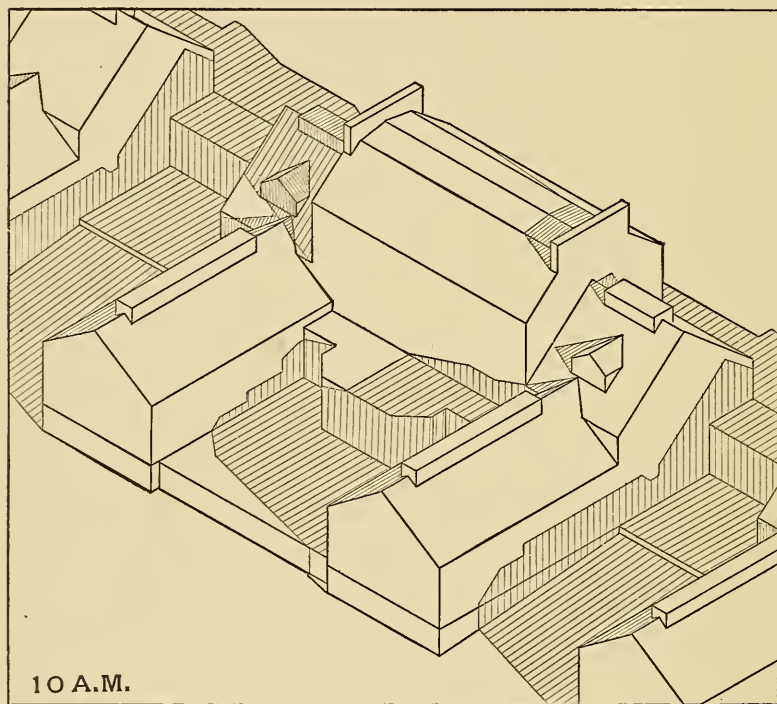

FIG. 61. — Pyramidal type of ward unit. Shadow diagram 10 A.M., winter solstice, Lat. $42^{\circ}-0'$ N.

clear or fourteen feet from floor to floor, for wards with flat ceilings, as a fair average, we should have in a three-story pavilion, as customarily planned, a height of forty-one feet from the first-floor level to the ceiling of the third floor.

If, however, we adopt what I have called the *Virchow idea*, of building the second story over the service portion of the first, and the third story over the service portion of the second, at the same time reducing the height of the

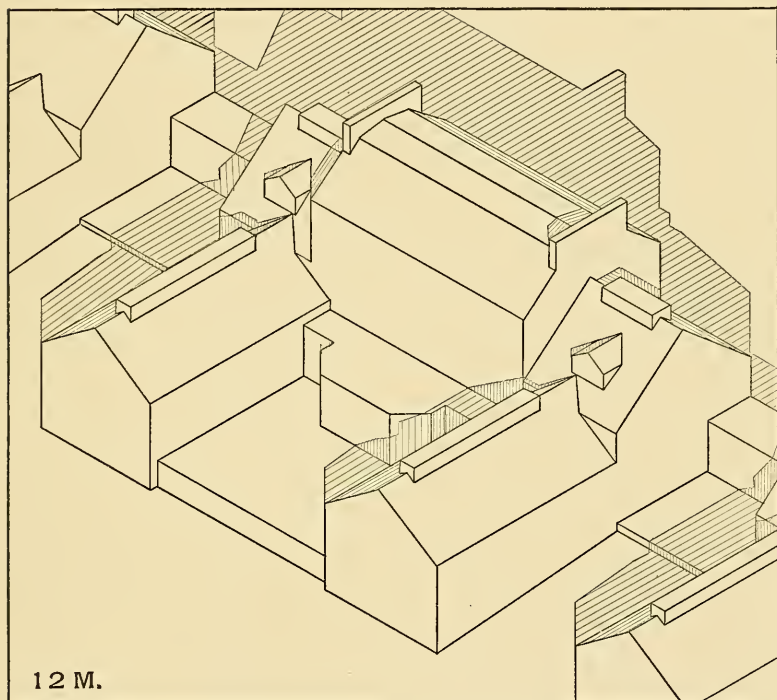

FIG. 62. — Pyramidal type of ward unit. Shadow diagram 12 M., winter solstice, Lat. $42^{\circ}-0'$ N.

service rooms to nine feet in the clear, which is ample, we shall obtain as the height of the three-story portion of our building, from the first-floor level to the ceiling of the third floor, thirty-three feet, — a saving of eight feet over the customary construction.

This reduction in height, combined with the successive reduction in area of each story, makes it possible to place the buildings at the minimum distance apart. In the plan (Fig. 64) the distance between adjacent pavilions is thirty-six feet,

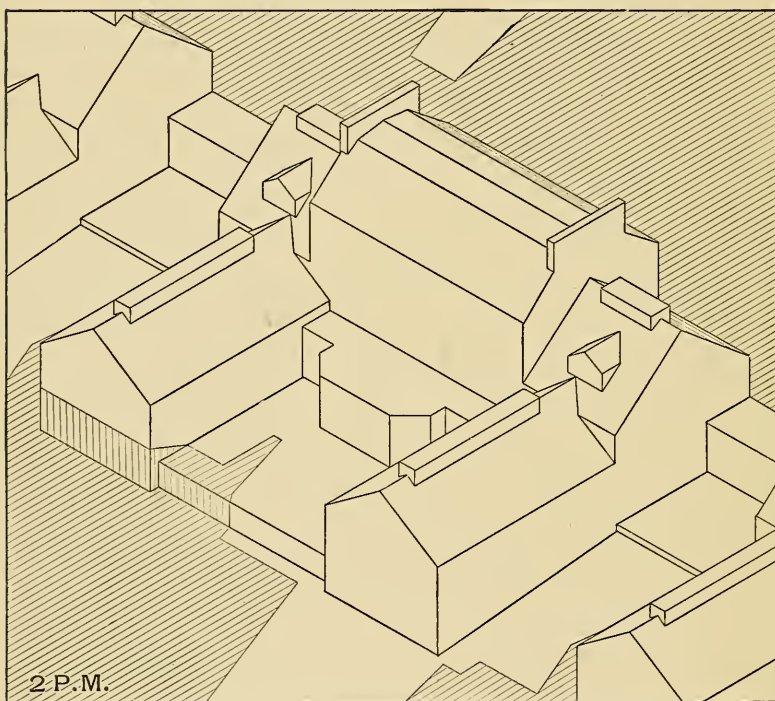

FIG. 63. — Pyramidal type of ward unit. Shadow diagram 2 P.M., winter solstice, Lat. $42^{\circ}-0'$ N.

and the shadow diagrams (Figs. 61, 62, and 63) demonstrate that this distance, with the orientation adopted, is ample to secure adequate sunlight, even at the winter solstice.

And thus the first requirement of our program is satisfied, that the distance between adjacent pavilions should

be reduced to the minimum consistent with adequate light and air.

Referring to the general plan (Fig. 64), it will be seen that between the two groups of pavilions extends an open space of ample dimensions, — one hundred feet wide, and something over six hundred feet long. This is the *Mittel Allee* of our hospital. Its general level is several feet above that of the rest of the grounds, and its vista is closed at one end by the *Administration Building*, a low one-story structure, and at the other by the *Chapel*. Between the first group of pavilions and the street is also a wide, open space, but at a lower level than the other.

And thus the second requirement of our program is met, that there should be adjacent to the pavilions, but not between them, large areas of open ground easily accessible to the patients.

Each of the pavilions provides for forty-five beds, disposed as follows, in wards of various sizes, aspects, and conditions: On the first floor two open wards of ten beds each; on the second floor two open wards of six beds each, and three single rooms; and on the third floor one open ward of four beds and an open-air ward of six beds.

And thus the third requirement of our program is met, that the pavilion should provide for a proper subdivision of the patients.

The two open wards on the first floor are of the arched section shown in Fig. 50 and provided with ridge ventilation. The two open wards on the second floor have sloping ceilings following the slope of the roof, and are also provided with ridge ventilation. The ward on the third

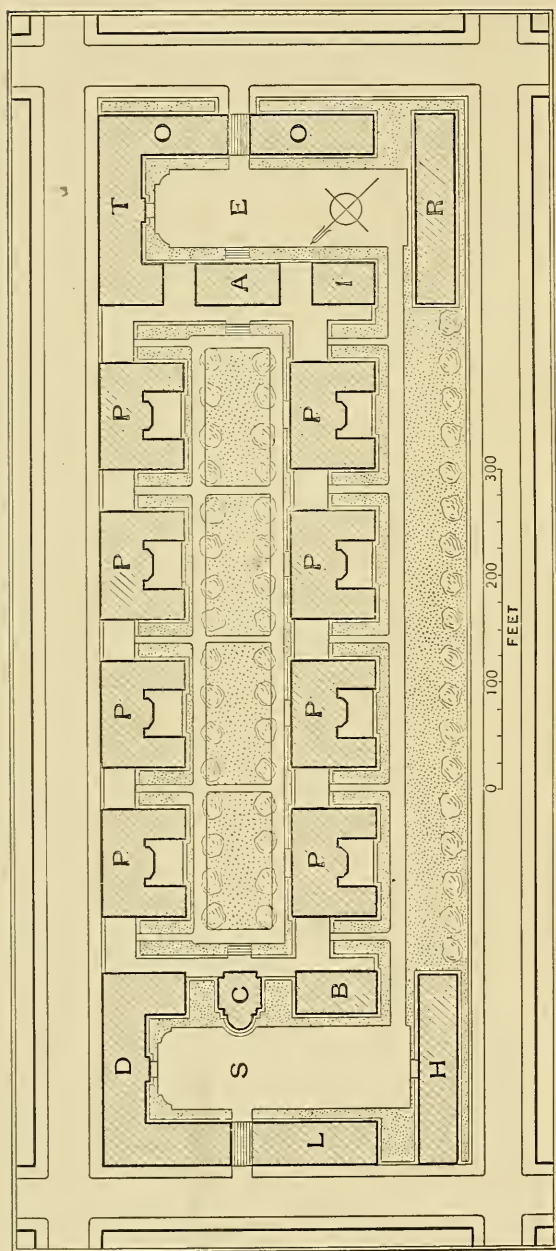

FIG. 64. Grouping of ward units of the pyramidal type to form a complete hospital.

REFERENCES.

- A. Administration building, one story high. T. Clinical building, five stories high. O. Out patient department, five stories high.
 R. Reception of patients building; two stories high. I. Apothecary's building, two stories high. P. Ward pavilions of the pyramidal type, for forty-five beds each. D. Domestic service building, five stories high, containing the kitchens, dining-rooms, dormitories for help, and power plant. C. Chapel, one story high. B. Hydrotherapeutic building, two stories high. H. Nurses' building, five stories high. L. Laundry building, five stories high. E. Entrance court yard. S. Service court yard.

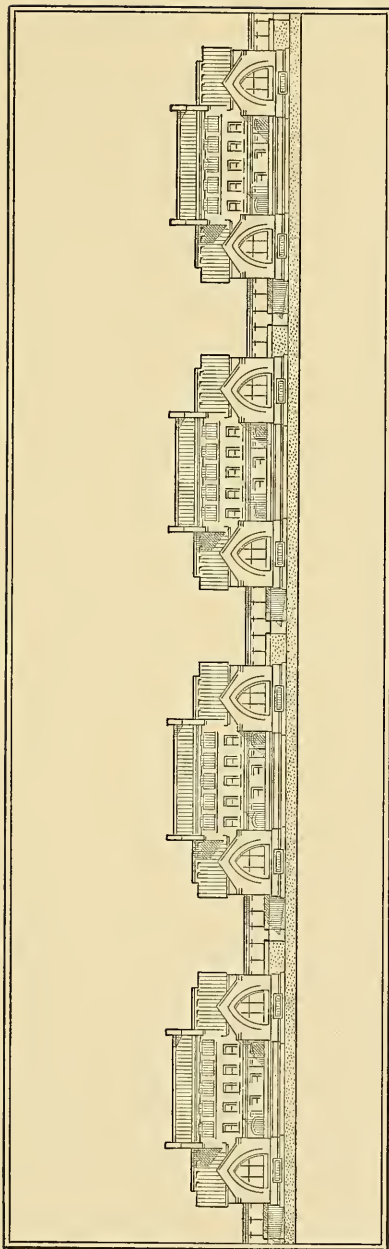

FIG. 65. — Elevation of one group of four ward units, as arranged in the preceding plan.

floor is open to the roof, and is also provided with ridge ventilation.

And thus the fourth requirement of our program is met, that all of the wards should have ridge ventilation.

The patients on the first floor have access to the terraces (*T* and *R*), which are at the same level as the floor of the wards and overlook the *Mittel Allee*, which is reached by a gentle incline from the terraces (*R*) between the pavilions. The roof of the connecting corridors is constructed to serve as a terrace for the patients on the second floor, while the patients on the third floor have the open-air balcony or loggia (*SB*, Fig. 60).

And thus the fifth requirement of our program is met, that facilities for out-of-door treatment should be provided.

The roof of the *Hydrotherapeutic Building* is designed to be flat, and arranged as a roof garden, affording facilities for the true sun bath, in which the unclothed body is exposed directly to the sun's rays.

The general plan (Fig. 64) is designed to illustrate the adaptability of the pyramidal type of ward unit to a lot of comparatively restricted dimensions. It consists of a series of U courts facing southwest; and the high buildings of the service and administration groups, disposed in the same general shape, are so placed as not to interfere with the sunlight for the ward pavilions. The entrance court yard (*E*) and the service court yard (*S*) are at the level of the surrounding streets, and are reached by arched entrances at the basement level; the main entrance through the out-patient block (*O-O*) and the service entrance through the service block (*D-L*). The main

floor level of the buildings is one story above the level of the entrance court yards. All of the buildings have direct sunlight on all of their exterior walls at some time of day throughout the year, with the exception of one, in which there is a small *area of complete shadow*. This, in the light of previous discussions, the reader should easily be able to discover — and suggest a remedy.

It will be noted in this hospital plan that the direction of the streets has enabled us to adopt the best possible orientation for the buildings. If the streets enclosing our hospital lot had been laid out north and south, east and west, it would have been a difficult matter to work out a satisfactory plan.

In the next chapter we shall point out the principles which should govern the laying out of streets.

CHAPTER IV

STREETS

IN the study of streets there are two matters to be considered; sunlight and sky light. Sky light comes from all directions of the heavens; sunlight from only one direction, constantly varying with the revolution of the sphere. The direction or orientation of the street affects the sunlight particularly: the height of the buildings bordering upon it affects both.

To investigate the distribution of sunlight in streets we shall employ a method similar to that used in obtaining the shadow curves of the cube, and to simplify the problem the buildings on either side will be assumed to be built in blocks of uniform height, extending continuously in both directions.

Fig. 66 is the cross section of such a street running north and south; Fig. 67 a similar street running southeast and northwest, and Fig. 68 a similar street running east and west.

The full lines give the angle of inclination of the plane of the sun's rays at the period of the equinoxes, and since at this period of the year the sun's rays fall in the same plane throughout the day, the cross section of the east and west street, being at right angles with this plane, shows the same inclination for every hour.

The distribution of the sunlight may also be shown by

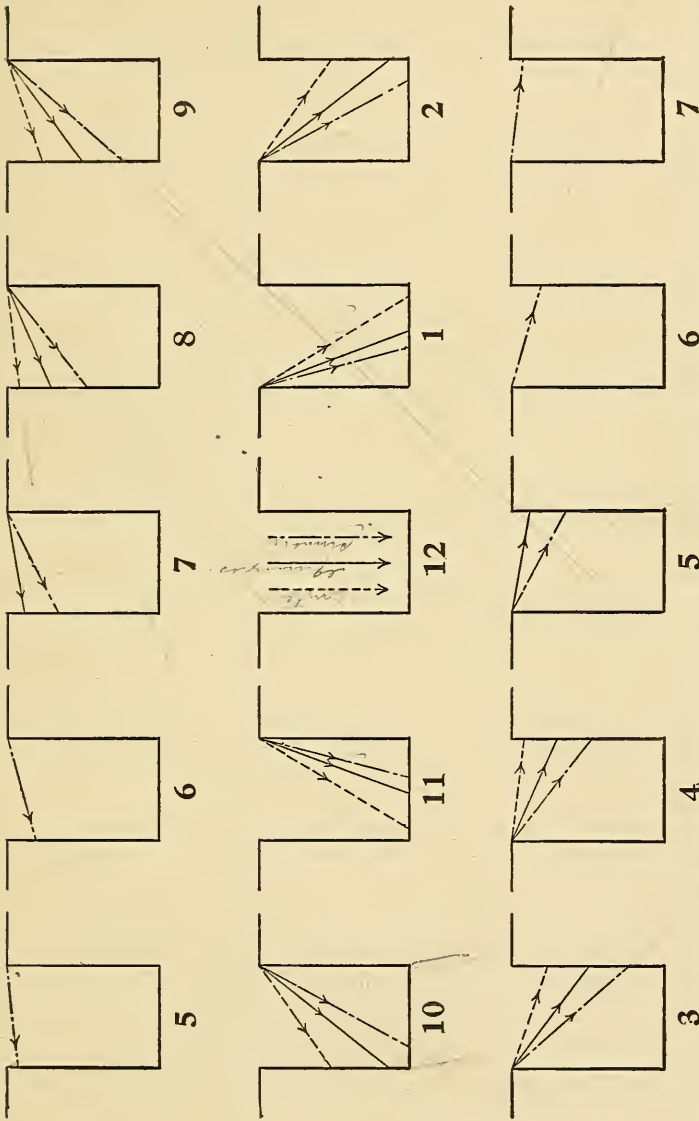

FIG. 66. — Cross section of street running north and south, showing the angles of sunlight for each hour of the day, and for the different seasons of the year.

The hours are shown by the numerals, beginning with 5 A.M. in the upper left hand corner. The dot and dash lines show the angles of sunlight at the summer solstice; the full lines the angles at the vernal and autumnal equinox; and the dotted lines the angles at the winter solstice. The section is taken looking north. The height of the buildings is one and a half times the width of the streets. Lat. $42^{\circ} - 6' N$.

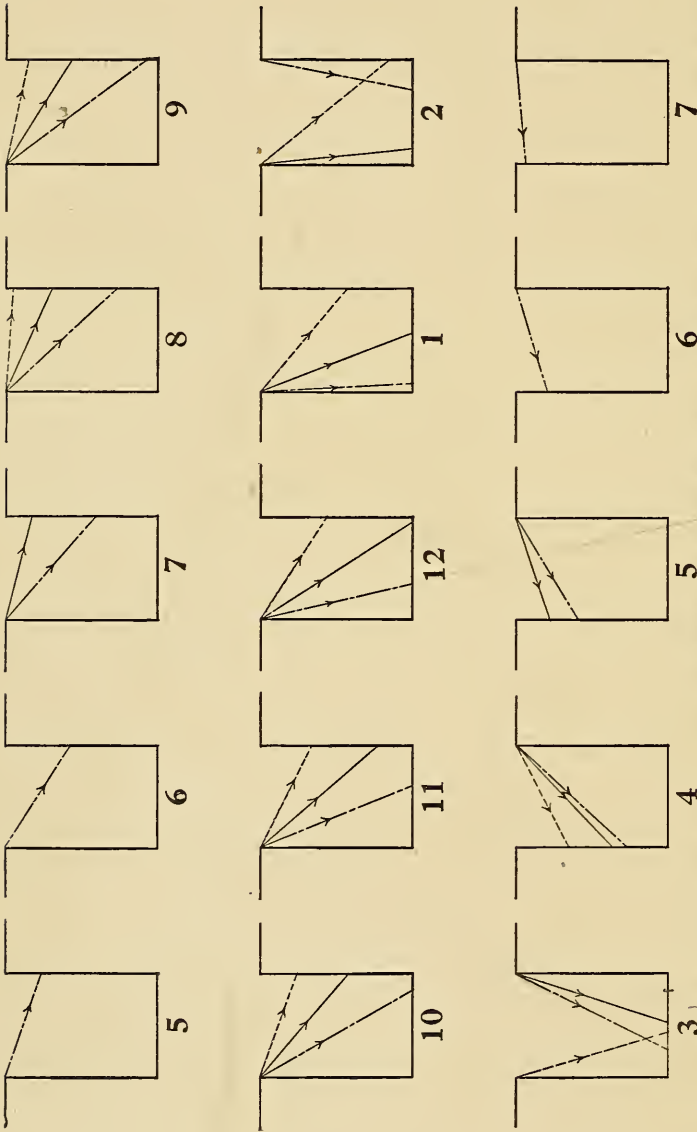

FIG. 67. — Similar diagram for a street running southeast and northwest looking southwest. Lat. $42^{\circ}-6' N$. This diagram will also serve for a street running southeast and northwest, the forenoon diagrams of the one corresponding to the afternoon diagrams of the other.

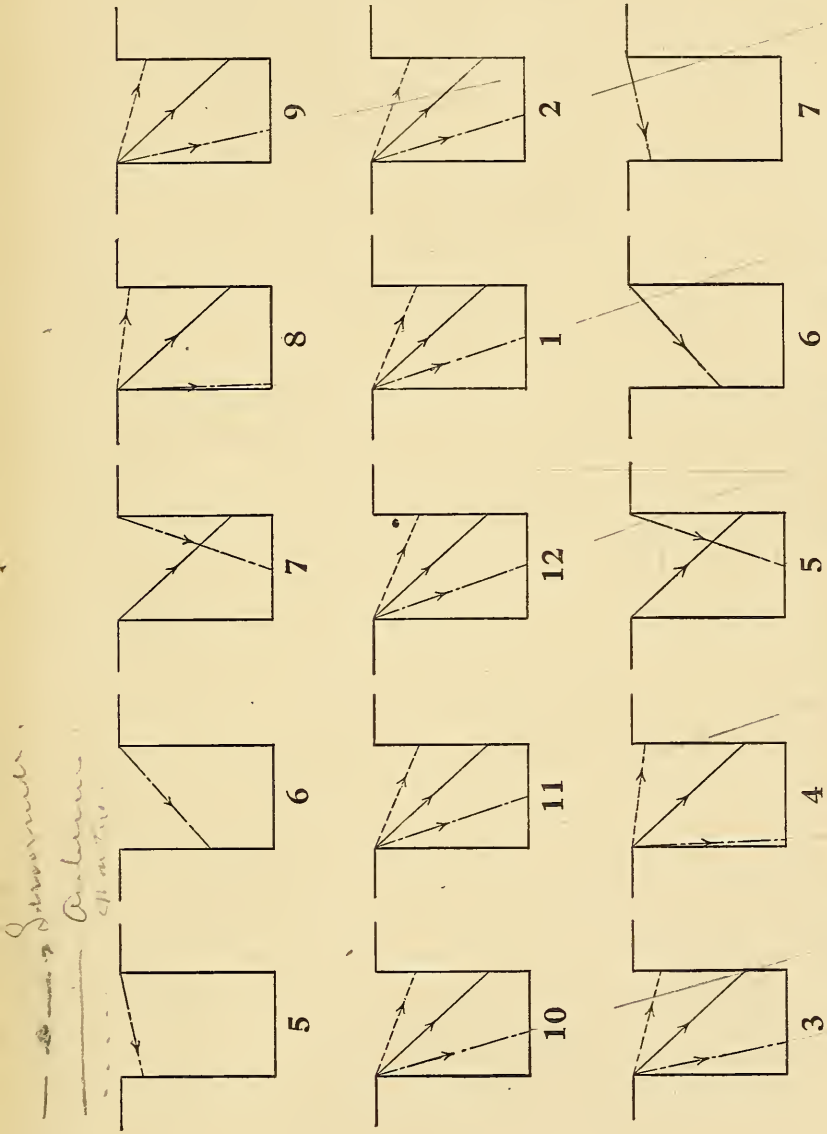

FIG. 68. — Similar diagram for street running east and west, looking west. Lat. $42^{\circ}-0' N.$

sunlight curves. The method of obtaining these curves is shown in Fig. 69.

This is a cross section of a street running southeast-northwest, taken looking northwest.

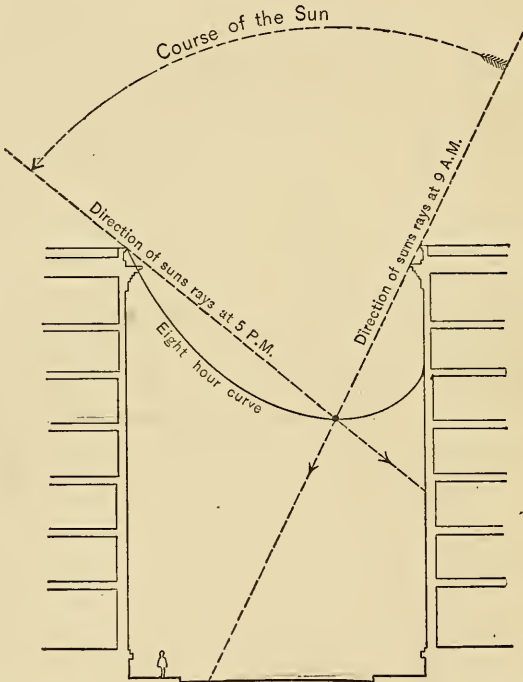

FIG. 69. — Cross section of street running southeast and northwest, looking northwest. The angles of sunlight are shown as they would be at the summer solstice. Lat. $42^{\circ}-0' N$.

The dotted lines represent the plane of the sun's rays at the hours noted. It is clear that the point of intersection of these lines first comes into sunlight at 9 A.M., remaining in sunlight until 5 P.M., a period of eight hours.

By finding a series of such points and connecting them, we shall obtain the curve shown, each point of which is in sunlight for eight hours, and may, therefore, be called the "eight-hour curve."

It is in this way that the following series of diagrams have been drawn (Fig. 70).

These diagrams give the complete series of sunlight curves at the typical seasons of the year, for streets running north-south, east-west, and at an angle of 45° with the meridian.

In these diagrams the height of the buildings is represented as one and one-half times the width of the street.

The diagrams show a great difference in the amount of sunlight received.

In the north-south street the distribution is symmetrical, the buildings on either side receiving an equal amount.

In the east-west street the surface of the street receives no sunlight at all during six months of the year, and the buildings on the south side of the street are in perpetual shadow during the same period.

In city planning the east-west street should be avoided as far as possible, and where unavoidable the buildings, especially on the south side, should be of moderate height, and built in detached blocks, so as to admit the sunlight between them.

When streets are laid out at right angles to each other according to the "checkerboard" plan, the best distribution of sunlight is obtained when one series of streets runs north-east-southwest and the other northwest-southeast.

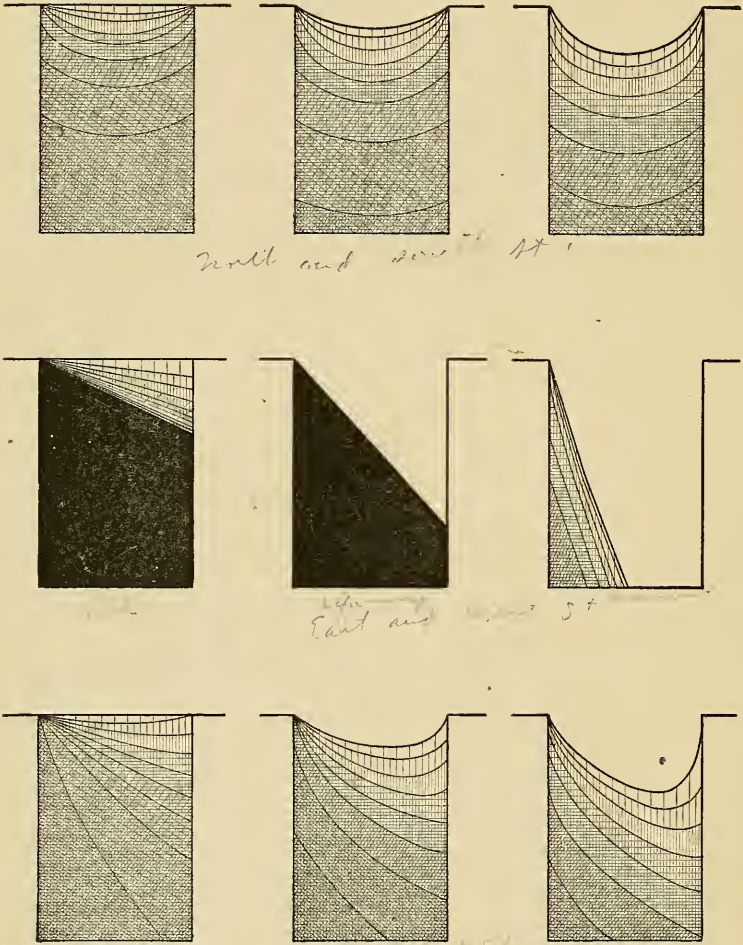

FIG. 70.—Sunlight curves in streets. The three upper diagrams are for a street running north and south, the three middle diagrams for a street running east and west, and the three lower diagrams for a street running at an angle of 45 degrees with the meridian. The diagrams of the left-hand column are drawn for the winter solstice; of the center column for the vernal and autumnal equinox; and of the right-hand column for the summer solstice. The zones between the curves are shaded in a series of tints, the lightest zone being in sunlight between eight and nine hours, and the solid black being without sunlight.

This arrangement was recommended many years ago by Horace Bushnell.

In his essay on *City Plans*¹ occurs the following passage:

“It is also a great question, as respects the health of the city, in what direction, or according to what points of the compass, the streets are to be laid. To most persons it will appear to be a kind of law that the city should stand square with the cardinal points of the compass, — north and south, east and west. And where this law appears not to have been regarded, how many will deplore so great an oversight, and even have it as the standing regret of their criticism. Whereas, in the true economy of health and comfort, no single house or city should ever stand thus, squared by the four cardinal points, if it can be avoided. On the contrary, it should have its lines of frontage northeast and southwest, northwest and southeast, where such a disposition can be made without injury in some other respect; that so the sun may strike every side of exposure every day in the year, to dry it when wet by storms, to keep off the mould and moss that are likely to collect on it, and remove the dank sepulchral smell that so often makes the tenements of cities both uncomfortable and poisonous to health.”

It is unfortunate that in so many cases where the “checkerboard” plan has been adopted, the streets have been laid out north-south and east-west, which is the worst arrangement possible.

The effect of tall buildings in cutting off sunlight and sky light from buildings on the opposite side of the street,

¹ *Work and Play*, Horace Bushnell, N.Y., Charles Scribner, 1864.

and from the street itself, is considerable, and in the building laws of most European cities a definite relation has been established between the width of the streets and the height of the buildings which may be built upon them.

An admirable example of such a regulation is found in the building laws of Paris, in which the matter is worked out with a precision and completeness well worthy of study.¹

The accompanying diagram (Fig. 71) illustrates its application to a street 16 meters (52.48 feet) in width.

The main structure of the building must be built within the limits of the heavy enclosing line, which is determined as follows:

The height of the vertical *AA* is taken at 6 meters plus the width of the street, for streets less than 12 meters in width, and for streets over that width it is taken at 18 meters, plus one-quarter of the amount by which the width of the street exceeds 12 meters, but must not exceed 20 meters (65.60 feet) in any event. For a street of 16 meters the height *AA* will, therefore, be 19 meters (63.32 feet).

From the top of this line a circular arc is drawn, and tangent to it a line of 45° inclination. This tangent is extended until it meets a vertical halfway back in the building or until it meets a similar tangent determined by the frontage of the rear portion of the building.

The radius of this arc is taken at one-half the width of the street, but may not exceed 10 meters (32.80 feet) in any event.

A similar regulation governs the rear façade of the build-

¹ The Paris law is given in full in Appendix B.

ing and also all frontages on light courts and areas, the result being an abundance of light and air throughout the structure.

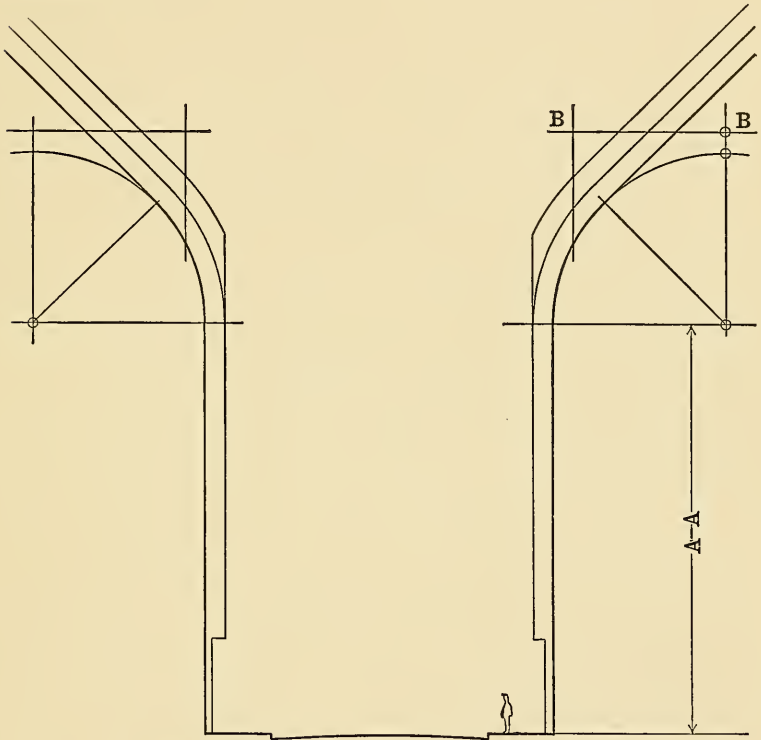

FIG. 71. — Diagram illustrating the building regulations of Paris, applying to the height of buildings. The vertical *A-A* and the radius of the circular arc vary with the width of the street. The horizontal *B-B* marks the limit of height for party walls, and the vertical line above the curve and just back of the front wall line, marks the setback for chimneys. The lighter enclosing lines beyond the heavy line mark the limit of projection for balconies, cornices, and other projections from the main structure.

In England the matter is regulated in two ways: directly, by building by-laws limiting height, varying in different cities and for different classes of buildings; and indirectly,

by the statute law of *ancient lights*. Under this law an owner or tenant of a building may acquire a right to light coming across the property of another, just as in this country a right of way across the land of another may be acquired by prescription.

“Cujus est solum ejus est usque ad cœlum” is an ancient maxim of our common law, and in the words of an English writer, “An interference with the space superincumbent on a man’s land is an injury for which the law provides a remedy.”

In England the deprivation of light is regarded as such an interference, actionable at law, but in this country the individual owner, where not restrained by specific statutes, is allowed to build as high as he pleases, regardless of the injury done to his neighbors and to the public, and even the right of a municipality to impose a limit to the height of buildings has been contested.

A recent decision (May 17, 1909) of the Supreme Court,¹ however, upholds the constitutionality of such building laws, and even that city which has taken a mistaken pride in having originated the “skyscraper” type of architecture has recently imposed a maximum limit of 210 feet to the height of its buildings.

In my own city of Boston a law has been in force since 1892 limiting the height of buildings generally to two and one-half times the width of the street, with a maximum limit of 125 feet; and subsequent legislation has reduced this limit in certain districts of the city.

¹ Welch vs. Board of Appeal of the City of Boston. U. S. Reports, Vol. CCXIV, page 91.

The regulations of some other American cities in this regard are given in Appendix C.

The method of limiting the height of buildings by a horizontal plane, either at a fixed height, or at a height proportional to the width of the street, is simple in application but is not scientific, since it assumes that what is the proper height for the front wall or facade is also the proper height for the rear portions of the building; whereas, as a matter of fact, the rear portions may well be allowed to rise to a greater height, in proportion to their distance back from the street line.

This method also results in an uninteresting and hard type of architecture. The land owner, intent on securing every foot of rentable space, duplicates one story on top of another, with the usual result that the cornice is forced above the level of the real roof as shown in Fig. 72, cutting off the sunlight and darkening the street unnecessarily.

This false position of the cornice constitutes the distinguishing mark of ordinary American civic architecture, and is the direct result of unscientific building laws.

Although a building law designed solely for the purpose of securing an æsthetic effect would probably be decided to be unconstitutional in this country, it fortunately happens that in the matter of regulating the height of buildings, that method which naturally results from a scientific study of the question of sunlight also tends to produce the best type of architecture.

A method which has been proposed by several architects, and which has also been advocated by the writer, is illustrated in Fig. 73.

Under this plan the height of the building is limited by a slanting line drawn from the opposite side of the street at a certain angle. This angle should be, in the opinion

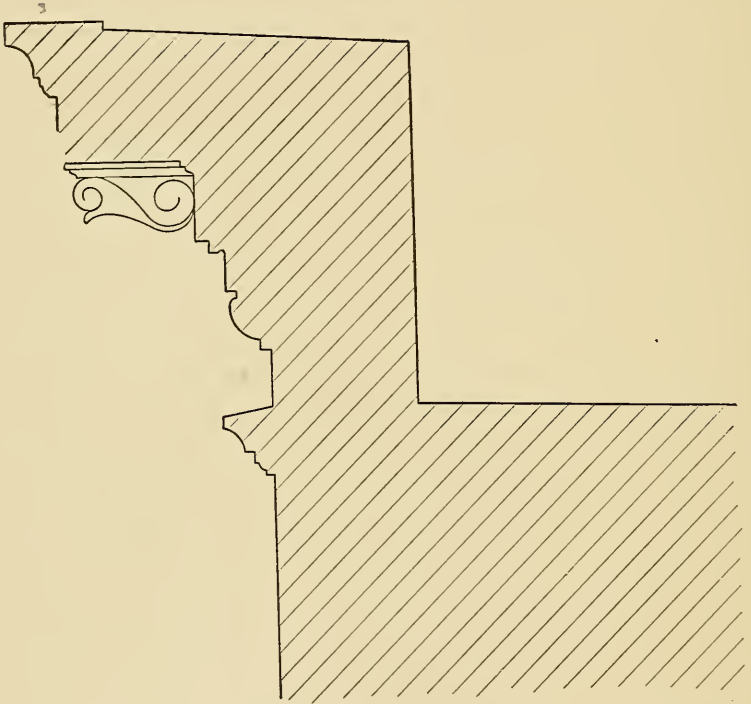

FIG. 72. — This type of cornice is typical of American commercial architecture. It is not really a cornice but a distorted parapet wall, and is also bad from the practical point of view because it cuts off the sunlight unnecessarily. It is the direct result of unscientific building laws, which apply the limit of height to the highest point of the roof, often several feet below the top of the exterior walls of the building.

of the writer, such that the height of the front wall of the building should not exceed one and one-quarter times the width of the street, and it is so shown in the diagram.

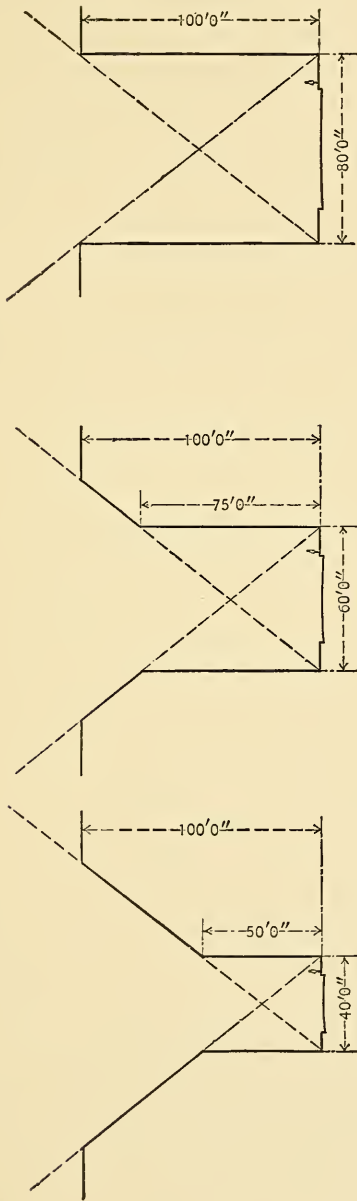

FIG. 73. — A method of limiting the height of buildings which has been advocated by many architects.

The height of the buildings is limited by the slanting lines, which at the angle indicated allow a height of one and a quarter times the width of the street at the street line, and an increase of twelve feet and a half for every ten feet of setback. The maximum height is also limited by a horizontal plane at a fixed height above the street, but this second limitation may well be omitted and the height throughout governed by the slanting line alone.

Under this arrangement a building on a street 100 feet wide (and in a modern city the principal thoroughfares should never be less than this, and with half their width devoted to sidewalks) might have a height of 125 feet at the street line, and retreating stories above this height to an extent limited only by the depth of the building.

In addition to the slanting line the extreme height of the roof is limited by a horizontal plane at a height uniform for all buildings, irrespective of the width of the street.

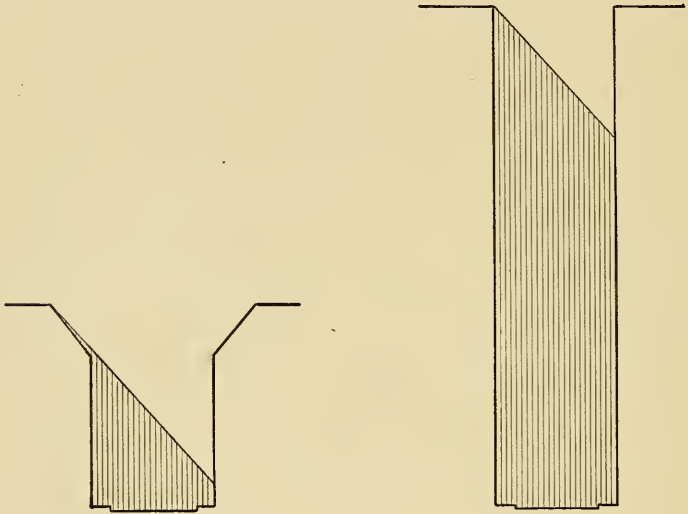

FIG. 74. — The skyscraper and the street. The left-hand diagram is a cross section of a street bordered by buildings of reasonable height; the right-hand diagram a street with a wall of sky scrapers on either side. The street is supposed to run east and west and the shadows show the angle of sunlight throughout the day, at the vernal and autumnal equinox. Lat. $42^{\circ}-0'$ N.

A similar method may well be adopted to regulate the walls of the building fronting on light courts and areas, and for this purpose an angle of less inclination from the vertical may be justified.

In discussing the question as to what should be the limit of height of buildings in cities it is proper to assume that both sides of the street will in time be built up to whatever limit is decided upon. The effect of a few scattered tall

buildings in darkening the streets is not serious, but the effect of a solid wall of skyscrapers would be extremely so.

In the accompanying diagrams (Fig. 74) is shown the section of a street 60 feet wide, in the one case bordered with buildings 250 feet high and in the other with buildings regulated in accordance with the building law proposed by the author. Which of the two should be typical of the American city planning of the twentieth century is left to the judgment of the reader.

APPENDIX A

SUN TABLES

Hour angle.	Winter Solstice.		Equinoxes.		Summer Solstice.	
	Az.	Alt.	Az.	Alt.	Az.	Alt.
120°					127° 42'	1° 21'
105°					116° 4'	9° 30'
90°			90° 0'	0° 0'	105° 7'	18° 7'
75°			78° 10'	9° 23'	94° 0'	27° 20'
60°			65° 41'	18° 5'	82° 2'	36° 40'
45°	40° 40'	5° 14'	51° 57'	26° 6'	68° 10'	45° 39'
30°	27° 59'	10° 25'	36° 25'	32° 36'	50° 48'	53° 43'
15°	14° 9'	13° 48'	18° 54'	36° 58'	28° 2'	59° 40'
0°	0° 0'	15° 3'	0° 0'	38° 30'	0° 0'	61° 57'

Sunrise and Sunset

3 h. 48 m.	50° 16'	0° 0'				
6 h. 0 m.			90° 0'	0° 0'		
8 h. 12 m.					129° 44'	0° 0'

LONDON. Lat. 51° 30' N.

Hour angle.	Winter Solstice.		Equinoxes.		Summer Solstice.	
	Az.	Alt.	Az.	Alt.	Az.	Alt.
90°			90° 0'	0° 0'	110° 35'	11° 27'
75°	62° 24'	0° 22'	82° 22'	12° 57'	104° 18'	23° 52'
60°	54° 9'	11° 20'	73° 54'	25° 39'	98° 16'	36° 36'
45°	44° 7'	21° 16'	63° 26'	37° 46'	91° 47'	49° 32'
30°	31° 44'	29° 3'	49° 6'	48° 36'	83° 27'	62° 30'
15°	16° 47'	34° 41'	28° 11'	56° 47'	67° 29'	75° 6'
0°	0° 0'	36° 33'	0° 0'	60° 0'	0° 0'	83° 27'

Sunrise and Sunset

5 h. 2 m.	62° 38'	0° 0'				
6 h. 0 m.			90° 0'	0° 0'		
6 h. 58 m.					117° 22'	0° 0'

NEW ORLEANS. Lat. 30° 0' N.

APPENDIX B

DECREE REGULATING THE HEIGHT OF BUILDINGS AND PROJECTIONS FROM THE SAME IN THE CITY OF PARIS. AUGUST 13, 1902

ARTICLE 1. The limits beyond which buildings upon the public ways of Paris are not allowed to project is fixed: first: by two "limiting cross sections" established, one for the structure proper, and the other for projections forming an integral part of the structure; second: by special rules set forth under Title II, Sections III and IV of this decree, for projections not forming an integral part of the structure.

TITLE I

HEIGHTS OF BUILDINGS

FIRST SECTION. BUILDINGS ON PUBLIC WAYS

ART. 2. The "limiting cross section" of the structure proper is determined by a vertical line erected on the front line of the lot.

The height of this line, measured from the sidewalk level or the level of the pavement at the foot of the façade and taken at the middle point of this façade, is calculated thus.

For streets less than 12 meters (39.36 feet) in width, the height must not exceed 6 meters (19.68 feet) plus the width of the street.

For streets of 12 meters and over this height must not exceed 18 meters (58.64 feet) plus one-quarter of the amount by which the width of the street exceeds 12 meters, but must not in any case exceed 20 meters (65.60 feet).

In calculating this height a fraction of a meter in the width of the street is taken at one meter.

On sloping streets the façade of the buildings is divided into sections not exceeding 30 meters (98.40 feet) and the height of each section is taken in the middle.

In the case of several distinct buildings the height of each is taken separately according to the above rules.

ART. 3. The "limiting cross section" referred to in the preceding article is completed by a circular arc, tangent to the vertical line, at its highest point, and by another line tangent to this circular arc.

The radius of the circular arc is taken at half the width of the street but must not exceed 10 meters (32.80 feet). However, for streets less than 12 meters (39.36 feet) it need not be reduced to less than 6 meters (19.68 feet).

The other line referred to, tangent to this circular arc, is drawn with an inclination of 45 degrees until it meets a vertical erected in the middle of the depth of the building, taken at the ground floor level.

However, it is allowed, if desired, to prolong this inclined line until it meets the tangent of another such circular arc established as described above on the highest point of the vertical line referred to in Article 10. The inclination of this second tangent must also be 45 degrees.

In any case, excepting for chimney stacks, the highest point of party walls between two buildings must not be built more than one meter (3.28 feet) above the horizontal tangent of the circular arc, excepting as provided in Article 6.

ART. 4. At street intersections the "limiting cross section" is determined according to the open space between the façades at such intersections, taken at right angles, and considered as the width of the street according to Article 2. But such additional height is allowed only for that portion of the façade which is opposite such open space.

Nevertheless, every building built upon a corner of two streets of unequal width, whatever may be their level or slope, may be built upon the narrower street up to the height allowed for the wider of the two, provided that such additional height does not extend back on the narrower street for a distance greater than one and a half times its width.

For buildings built upon a corner formed by two streets of equal width but of different slopes, the height is taken as the average for the middle points of each frontage. But frontages on which the height is taken conformably to the level of the street on which such frontages face, as for separate buildings, need not be reckoned in determining such middle point.

ART. 5. For buildings comprised between streets of different widths or of different levels the "limiting cross section" for each façade must be determined by the street upon which it faces.

However, if the extreme distance between two such façades does not exceed 15 meters (49.20 feet) the façade upon the narrower or lower street may be built up to the "limiting cross section" fixed for the façade upon the wider or higher street.

ART. 6. Chimney stacks may not be built more than one meter (3.28 feet) above the highest point of the "limiting cross section" and their front face must be at least one meter back of the front line.

ART. 7. For portions of a building projecting beyond or built back of the general building line the "limiting cross section" referred to in Article 2 is based upon a street width equal to the distance between the extreme projection of the façade and the street line opposite.

In such calculations, fractions of a meter are taken as equal to a meter.

Buildings or sections of buildings built at the ground story or on the stories above, back of the street line, may be built within the "limiting cross section" permitted for a street the width of which is equal to the distance between the street line opposite such building or section of building, provided that there is built on the street line a solid and substantial wall at least one meter high.

ART. 8. Buildings which are not built up to the "limiting cross section" permitted may be constructed in all parts as the builder desires, provided they do not project beyond such "limiting cross section."

SECOND SECTION. BUILDINGS ON AREAS AND COURTS

ART. 9. Courts which furnish light and air to rooms capable of being used for purposes of habitation, either in the daytime or at night, must have an area of 30 meters (322.80 square feet) at the least.

For courts which only light such rooms as kitchens the minimum area may be reduced to 15 meters (161.40 square feet).

Small courts or "light shafts" serving to give light and air to rooms which cannot be used for purposes of habitation must have an area of 8 meters (86.08 square feet) at the least.

ART. 10. The clear space opposite each window of a room serving for day or night habitation must not be less than is provided in the following table.

Minimum Area of Court.	Clear Space.	Minimum Area of Court.	Clear Space.
Square Feet.	Feet.	Square Feet.	Feet.
322.80	13.12	502.06	18.56
358.63	14.20	538.00	19.68
394.46	15.28	573.83	20.76
430.40	16.40	609.66	21.84
466.23	17.48		

For buildings opposite party walls the minimum clear space opposite windows of habitable rooms is 5 meters (16.40 feet).

The "limiting cross section" of buildings or parts of buildings situated on courts, composed of the same elements as indicated in Articles 2 and 3, is determined by the following table.

Minimum Clear Space.	Maximum Height of Vertical.	Maximum Radius of Arc.
Square Feet.	Feet.	Feet.
13.12	39.36	19.68
14.20	42.64	21.32
15.28	45.92	22.96
16.40	49.20	24.60
17.48	52.48	26.24
18.56	55.76	27.88
19.68	59.04	29.52
20.76	62.32	31.16
21.84	65.60	32.80

Buildings or parts of buildings built in retreating stories may be built in each story according to the "limiting cross section" determined separately for that story according to the clear space opposite that story.

The ground level of every court is considered independently of that of the public street or of another court.

Stairway towers or bays arranged in such courts may project beyond the "limiting cross section" as above determined up to the ceiling level of the highest story served by such stairway.

ART. 11. In the case of courts which only furnish light and air to such habitable rooms as kitchens, the dimensions of the "limiting cross section" may be modified as per the following table.

Minimum Area of Court.	Minimum Clear Space.	Maximum Height of Vertical.	Maximum Radius of Arc.
Square Feet.	Feet.	Feet.	Feet.
161.40	6.56	39.36	19.68
179.26	7.08	42.64	21.32
197.23	7.64	45.92	22.96
215.20	8.20	49.20	24.60
233.06	8.76	52.48	26.24
251.03	9.28	55.76	27.88
269.00	9.84	59.04	29.52
286.86	10.36	62.32	31.16
304.83	10.92	65.60	32.88

ART. 12. The vertical walls of "light shafts" may be built to the height determined for the building in general.

The clear space opposite windows in "light shafts" must not be less than 1 m. 90 (5.33 feet).

Kitchens of the concierge on the ground floor may take their light and air from "light shafts."

On the top story of buildings habitable rooms may take their light and air from "light shafts."

ART. 13. In any case the minimum area of light courts and shafts as determined by Article 9 may not be diminished by new construction or selling of property.

ART. 14. Glass roofs may not be built over light courts or shafts above the rooms which take their light and air from them, whether rooms of habitation, kitchens or water closets, unless such glass roofs have monitor ventilating sash with a clear opening of at least one-third the area of the court and of a minimum height of 40 centimeters (15.72 inches), and unless also there are arranged at the bottom of such court or shaft openings communicating with the cellar or basement having at least 8 decimeters (8.56 square feet) of area. The monitor ventilation is not required for light wells and shafts unless they serve habitable rooms, kitchens, or water closets; but light shafts, the lower part of which does not communicate with the outer air, must be ventilated.

ART. 15. All measurements of light courts and shafts must be taken on the work.

ART. 16. Owners of adjoining buildings who may have made an agreement to have light courts and shafts in common may build them of the dimensions prescribed in Articles 9, 10, 11, and 12 for light courts and shafts belonging to a single building.

They must, in such case, notify the prefect of the Seine of their agreement and execute with the City of Paris, before commencing the work, an agreement to maintain such courts and shafts for their common use.

Such courts and shafts may be divided by walls of a height in accordance with article 663 of the civil code.

THIRD SECTION. STORY HEIGHTS

ART. 17. In all buildings bordering on public ways, private ways or courts, the height of the ground story and that of the next above must never be less than 2 m. 80 (9.18 feet) in the clear.

The height of basements and other stories must never be less than 2 m. 60 (8.53 feet) in the clear.

For the top story of a building this last height applies to the highest part of a sloping ceiling, and every room with a sloping ceiling in part must have at least 2 square meters (21.52 square feet) of level ceiling.

TITLE II

PROJECTIONS FROM BUILDINGS

FIRST SECTION. IN GENERAL

ART. 18. No projection may be built from any building in Paris, whether on the street line or not, so as to project over a public way, other than those authorized below.

ART. 19. For buildings on the street line, the front face of party walls must always mark the street line: for this purpose there must be reserved, at a height of a meter and a half above the ground, a level surface at least 20 centimeters square.

ART. 20. Dimensions of projections are fixed (saving the exceptions given below) according to the width of the street opposite the building if

on the street line, and according to the effective width for buildings set back.

All projections are measured from the street line for buildings upon the street line and from the ashlar line for buildings not on the street line.

In reckoning such width, fractions of a meter are taken as one meter.

SECOND SECTION. PROJECTIONS OF CONSTRUCTIONS FORMING A PART OF THE BUILDING PROPER

ART. 21. The limit of projections from the façade, for decorative features, foundations, balconies and built-out constructions, is determined by a "limiting cross section" established as follows:

This "limiting cross section" is composed of two vertical lines, one relating to the upper part of the façade from a point taken at the established height as determined in Article 2, and the other relating to the lower part of the façade.

The line separating these two parts, for streets of 30 meters (98.40 feet) and over is placed at a minimum height above the sidewalk of 3 meters (9.84 feet), and for streets less than 30 meters, at a height of 6 meters (19.68 feet) less one-tenth of the width of the street, above the sidewalk.

The projection of the "limiting cross section" from the street line is for the upper part of the façade 8 centimeters for every meter in the width of the streets up to streets of 10 meters in width, and 60 centimeters plus $\frac{2}{100}$ of the width of the street, with a maximum of 1 m. 20 (3.94 feet) for streets of 10 meters and over.

The projection of the "limiting cross section" for the lower part of the façade must not exceed one-quarter of the projection of the upper part, but need not be less than 20 centimeters (7.8 inches) in any event.

For the upper part of the façade, the plane of the street line must serve as the basis of all decoration and occupy, at each story, one-tenth at least of the surface of the façade of that story, after deducting bays.

ART. 22. There may be established upon the upper part of façades, constructions corbeled out, whose gross area, projected on a vertical plane parallel to the façade, may not occupy in any case, more than one-third of the total upper part of said façade.

For buildings having several façades upon the street, each façade shall be considered separately in such calculation.

Each dividing section counts with either one of the façades which it separates, at the choice of the constructor.

Laterally, and at the ends of buildings, the projections of the constructions are limited by a vertical plane forming an angle of 45 degrees with the front wall and intersecting it at 25 centimeters (9.8 inches) from the party line.

ART. 23. In streets of 16 meters (52.48 feet) of width and over, the established projection of every balcony may be increased one-quarter, provided that in horizontal projection the total of all balconies does not cover more than a quarter of the surface permitted at each story.

ART. 24. Notwithstanding Article 21, the decoration of the principal entrances of a building and that of the cornices of the ground story may descend to a height of 2 m. 50 (8.20 feet) above the sidewalk, with a projection equal to twice that permitted for the lower part of the façade.

In streets of 20 meters and over, the decoration of the principal entrances may descend to the ground, with a projection not over twice that permitted for the lower part of the façade.

ART. 25. Iron guards and other similar objects of iron-work intended to serve as defences on balconies may have 25 centimeters (9.8 inches) in excess of the projection allowed for the cornices, balconies and entablatures upon which they are fixed.

ART. 26. Roof ornaments, such as finials on dormers, open crestings and galleries, may not project beyond the arc of a circle concentric with that of the "limiting cross section" and of which the radius exceeds that of the latter by the permitted projection of the upper part of the façade.

In their total, the size of the crowning members of dormers may not exceed two-thirds of the frontage of the façade of the building, after deducting the crowning members of the corbeled-out structures projecting over the public way, as provided for in this decree.

For the crowning members of the corbeled-out constructions, the increase of radius referred to above, may equal twice the maximum projection permitted for the upper part of the façades, provided that spaces of habitable rooms do not exceed the limits of the concentric arc referred to above.

In the three above cases, the circular arcs are prolonged by their tangents at 45 degrees.

For corbeled-out constructions those portions of the crowning members which project above the established line of the roof may not exceed in width one-third of the portion on the façade proper.

THIRD SECTION. PROJECTION OF OBJECTS NOT FORMING AN INTEGRAL PART OF THE STRUCTURE

(This section consists of ten articles and deals with store fronts, grilles, signs, marquises, lights, rain-water conductors, etc.)

FOURTH SECTION

(This contains one article, dealing with temporary structures.)

TITLE III

SPECIAL REQUIREMENTS

(This contains seven articles, dealing with special cases, two of which are of sufficient interest to be given in full.)

ART. 38. Existing projections beyond the limits fixed by the present decree may not be repaired even in part, or restored, except within the limits established herein.

Except that in certain cases, ancient objects of archeological or artistic interest, may be repaired by permission of the prefect of Seine.

ART. 42. The prefect of the Seine may, in the case of private constructions having a monumental character, or for purposes of art, science, or industry and with the approval of the "conseil general des batiments civils" and the minister of the Interior, authorize exceptions from the present decree relative to the height of buildings.

He may also, following the same procedure, authorize exceptional projections for buildings having a monumental character.

ART. 44. The decrees of July 22, 1882, and July 23, 1884, are repealed.

APPENDIX C

REGULATIONS OF SOME OF THE PRINCIPAL CITIES OF THE UNITED STATES AND CANADA GOVERNING THE HEIGHT OF BUILDINGS

NOTE. — The regulations given are those which apply to buildings of fireproof construction. Limitations of height for non-fireproof buildings primarily imposed to decrease the fire hazard, rather than to prevent encroachments upon the light and air of the public streets, are not included in this list.

All of the regulations given are those in force in 1911.

Boston. — Since 1891 the height of buildings in all cities of Massachusetts has been limited to 125 feet.

Grain elevators, coal elevators, and sugar refineries are excepted, and steeples, domes, towers and cupolas are not included within the 125 feet limit.

In Boston this limit of height is subject to a further restriction of $2\frac{1}{2}$ times the width of the street, so that on streets of less than fifty feet in width the height must be less than 125 feet.

The maximum height of 125 feet is furthermore only permitted in those portions of the city in which the greater part of the buildings are used for business or commercial purposes. The boundaries of these portions have been determined by a commission appointed for the purpose and the areas within them are known as "District A."

The remainder of the city, comprising much the larger part of its area, is known as "District B" and within this district the limitations of height are as follows:

On streets of 64 feet in width, or less, the limit is 80 feet.

On streets exceeding 64 feet in width the height may be equal to $1\frac{1}{4}$ times the width of the street but may not exceed 100 feet. Furthermore a

height of 80 feet may not be exceeded unless the width of the building on each and every public street on which it stands is at least one-half its height.

In addition to these general regulations there are other special restrictions, as follows:

On certain streets in the vicinity of the state capitol the limit of height is 70 feet. Upon a portion of Commonwealth Avenue (one of the principal parkways of the city) the limit of height is 70 feet.

This latter restriction is imposed by the Park Commissioners, who have the power to impose such restrictions on any parkway, boulevard or public way bordering on a park, within the city.

Winnipeg. — Not exceeding 120 feet.

Montreal. — Not exceeding 130 feet nor over ten stories.

Portland. — Not exceeding 160 feet nor over ten stories.

Baltimore. — Not exceeding 175 feet, *except by special permission of the City Council.*

Cleveland. — Not exceeding 200 feet, nor more than $2\frac{1}{2}$ times the width of the street nor more than five times the width of the base.

Chicago. — Not exceeding 260 feet. (After July 11, 1911, not exceeding 210 feet.)

St. Louis. — The limit of height for all buildings other than hotels and office buildings is $2\frac{1}{2}$ times the width of the street, with a maximum limit of 150 feet.

The limit of height for hotels is 206 feet.

The maximum limit of height for office buildings is 250 feet, but this height is not permitted unless the building covers at least one-half of the city block in which it is built, has frontages on at least three different streets, and fulfills certain stringent requirements in regard to fire protection. Otherwise the limit of height for office buildings is the same as that for hotels, viz., 206 feet.

St. Paul. — Not exceeding 250 feet nor over twenty stories.

Toronto. — Not over five times the least horizontal dimension of the building.

Seattle. — Not over five times the least dimension of the base.

Indianapolis. — No limit, except in the neighborhood of the city monument, where a limit of 86 feet is imposed.

Cincinnati. — No limit.

Detroit. — No limit.

Hartford. — No limit.

Milwaukee. — No limit.

Minneapolis. — No limit.

New York. — No limit.

Philadelphia. — No limit.

COLUMBIA UNIVERSITY LIBRARY

This book is due on the date indicated below, or at the expiration of a definite period after the date of borrowing, as provided by the rules of the Library or by special arrangement with the Librarian in charge.

³ DATE BORROWED	DATE DUE	DATE BORROWED	DATE DUE
	JUN 3 1 '40		
	JAN 27 1941		
	JUN 26 1943		
JAN	24 1947		
FEB	28 1947		
APR	4 1947		
JUL	9 1947		
OCT 17	1949		

RA967

At5

Atkinson

