

A  
A  
0  
0  
1  
2  
1  
0  
3  
5  
0  
3



UC SOUTHERN REGIONAL LIBRARY FACILITY



THE LIBRARY  
OF  
THE UNIVERSITY  
OF CALIFORNIA  
LOS ANGELES

1908

CANADA  
DEPARTMENT OF MINES  
MINES BRANCH

HON. W. TEMPLEMAN, MINISTER; A. P. LOW, LL. D., DEPUTY MINISTER;  
E. HAANEL, PH. D., DIRECTOR.

---

PEAT AND LIGNITE  
Their Manufacture and Uses in Europe.

BY  
E. NYSTROM, M.E.

OTTAWA, CANADA.

1908.

19



CANADA  
DEPARTMENT OF MINES  
MINES BRANCH

HON. W. TEMPLEMAN, MINISTER; A. P. LOW, LL D., DEPUTY MINISTER;  
E. HAANEL, PH. D., DIRECTOR.

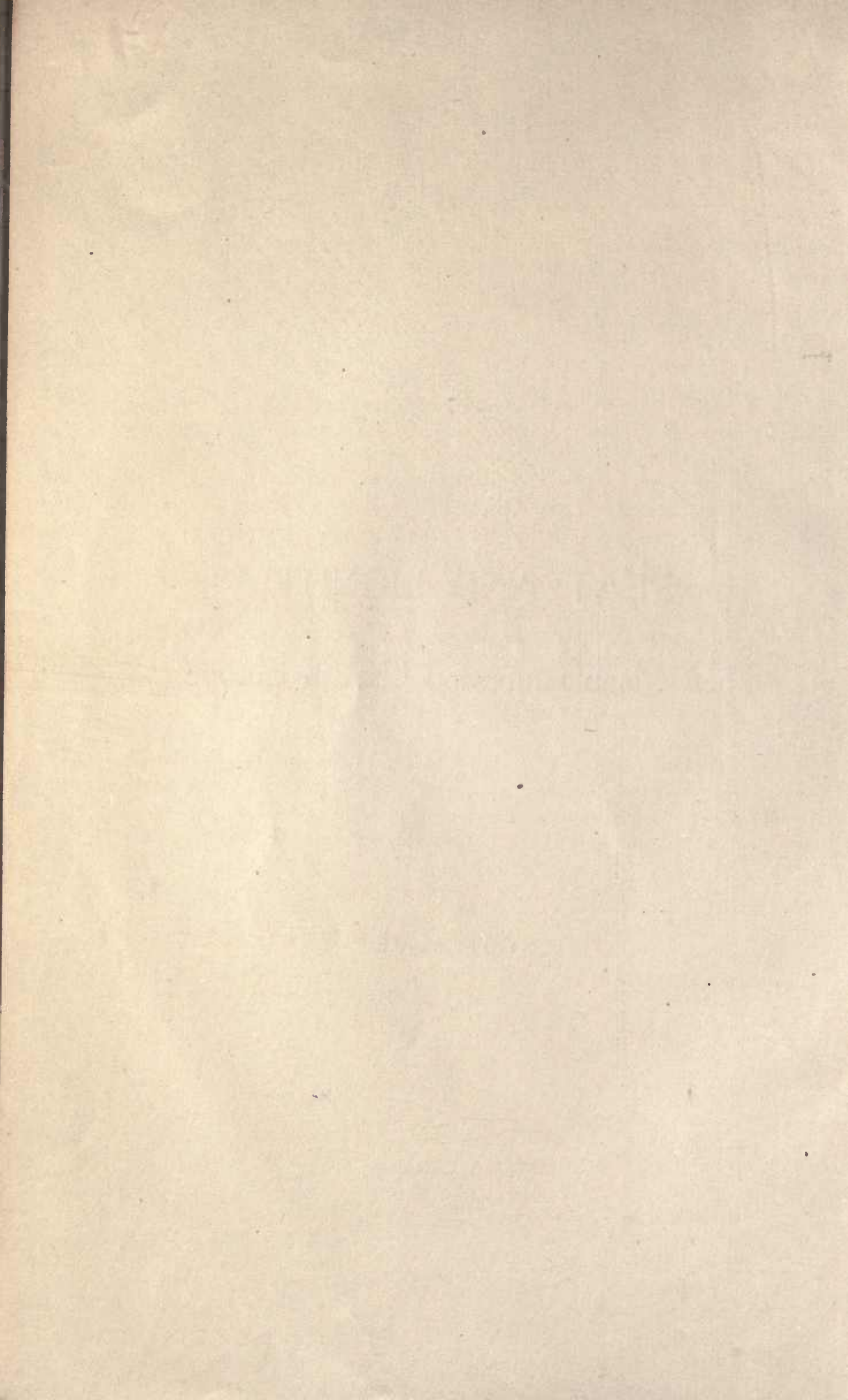
---

PEAT AND LIGNITE  
Their Manufacture and Uses in Europe.

BY  
E. NYSTROM, M.E.

OTTAWA, CANADA.

1908.



OTTAWA, 14th May, 1907.

SIR,

You are instructed to proceed at the earliest moment to Sweden, Norway, Finland, Denmark, Germany, Holland and Ireland, for the purpose of studying and reporting upon the Peat Industry in these countries. It will be your duty to familiarize yourself with the methods, processes and machinery employed in the commercial production of fuel from peat and lignite and such other exploitations of peat bogs as lead to commercial products.

This examination is undertaken in the interest of the Peat Industry of Canada, and it will, therefore, be your duty also to ascertain all facts relating to costs of production; to procure photographs, drawings and plans of machinery and apparatus used; and obtain information regarding patents issued to the different inventors of processes and machinery, the countries where they have been issued and full particulars thereof.

You are further instructed to visit the Peat Laboratories of such countries as have established them, familiarize yourself with the methods employed for determining the value and class of peat, and report upon these methods and the apparatus, equipment and arrangement of these laboratories.

Yours very truly,

EUGENE HAANEL,

Director of Mines.

ERIK NYSTROM, Esq., M.E.,

Mines Branch,

Ottawa.

787421





OTTAWA, March 25th, 1908.

SIR,

In compliance with your instructions to investigate the peat and lignite industries in Europe I beg to submit the accompanying report.

In this report the information collected during my visits to the different plants, as well as a large amount of information obtained from various publications on these subjects, is incorporated.

The report also includes descriptions of some of the processes used in Canada, and, whenever possible, diagrams or photos showing the construction of the machinery used and the methods employed have been secured and incorporated in the report.

I have the honour to be,

Sir,

Your obedient servant,

E. NYSTROM.

DR. EUGENE HAANEL,

Director of Mines,

Ottawa.



## TABLE OF CONTENTS.

	PAGE.
INTRODUCTION.....	1-8
CHAPTER I.	
ORIGIN, OCCURRENCE, CLASSIFICATION AND USES OF PEAT.....	9-13
CHAPTER II.	
COMPOSITION AND CALORIFIC VALUE OF PEAT.....	14-17
CHAPTER III.	
MANUFACTURE OF AIR DRIED PEAT FUEL.....	18-129
<i>General Requirements for a Successful Peat Fuel Manufacture.</i> . . .	19-20
<i>Preliminary Work.</i> .....	20-21
<i>Pumping Machinery.</i> .....	21-22
<i>Methods of Manufacture.</i> .....	22-129
I. CUT PEAT.....	22-33
a. <i>Cut Peat Dug by Hand.</i> .....	23-28
At Sparkaer.....	24-25
At Moselund.....	25
At Triangel.....	25-26
At Haspelmoor.....	26
At Raubling.....	26-27
At Bernau.....	27
At Feilenbach.....	28
In Oldenburg.....	28
In Russia.....	28
b. <i>Cut Peat Dug by Machinery.</i> .....	28-31
R. Dolberg's Cutting Machine.....	29-30
Peat Plant at Ostrach.....	30-31
<i>Special Drying Arrangements.</i> .....	31-33
II. MACHINE PEAT.....	33-129
1. MACHINE PEAT MANUFACTURED WITH ADDITIONAL WATER.....	34-57

	PAGE.
<i>a. Manufactured Without the Aid of Machinery</i> . . . . .	34
<i>b. Manufactured With the Aid of Machinery</i> . . . . .	34-57
<i>Arrangements at Smaller Plants</i> . . . . .	34-36
<i>Arrangements at Larger Plants</i> . . . . .	36-57
At Sparkaer . . . . .	36
At Ökaer . . . . .	36-42
At Stafsjö . . . . .	42-43
At Herning . . . . .	43-45
At Moselund . . . . .	45-47
At Aamosen . . . . .	47-51
At West Torup . . . . .	51-55
At Ilpendam . . . . .	55-56
At Elisabethfehn . . . . .	56-57
2. MACHINE FORMED OR PRESSED PEAT . . . . .	57-199
<i>Elevators</i> . . . . .	58
<i>Peat Machines</i> . . . . .	58-84
C. Schlickeysen's Peat Machines . . . . .	59-64
"    "    Excavator . . . . .	64
R. Dolberg's " Machines . . . . .	64-73
A. Heinen's "    "    . . . . .	73-76
L. Lucht's "    "    . . . . .	76-77
A. Anrep's "    "    . . . . .	77-82
Svedala "    "    . . . . .	82-83
Akerman's "    "    . . . . .	83-84
<i>Arrangement of Peat Machine and Motor</i> . . . . .	84
<i>Transportation and Laying out the Machined Peat for</i> <i>Drying</i> . . . . .	84-99
Anrep's Round Track with Mechanical Transpor- tation . . . . .	92-94
Anrep's Mechanical Transportation Combined with C. W. Jakobson's Field Press . . . . .	94-96
A. Körner's Arrangement for Transport to the Drying Field . . . . .	96-99
<i>Drying and Storing</i> . . . . .	99-102
<i>Description of Individual Peat Plants</i> . . . . .	102-120
Sweden: Tests with Anrep's Machine No. 1 B. at Stafsjö . . . . .	102-103
Tests with Anrep's Machine No. 11 B. at Stafsjö . . . . .	103
Tests with Svedala Machine No. 2 at Stafsjö . . . . .	104

	PAGE.
Koskivara.....	104-108
St. Olof.....	108-109
Yxenhult.....	109-110
Stafsjö.....	111
Russia.....	111-112
Germany: Beuerberg.....	112-114
Feilenbach.....	114-115
Triangel.....	115-116
Elisabethfehn.....	116-120
<i>Capacities of R. Dolberg's Peat Plants.....</i>	121
<i>Costs of Plants.....</i>	122-127
Abjörn Anderson's (A. Anrep's).....	123-126
A. Heinen's.....	127
<i>Approximate Cost of Production of Machine Formed Peat Fuel under Canadian Conditions with Anrep's Machine No. 1 B. Combined with Mechanical Transportation and Jakobson's Field Press.....</i>	128-129

## CHAPTER IV.

MANUFACTURE OF PEAT AND LIGNITE BRIQUETTES.....	130-170
<i>Drying Apparatus.....</i>	132-136
Steam Plate Drier.....	132-134
Schulz Drier.....	134-135
<i>Cooling Apparatus.....</i>	136
<i>Briquetting Presses.....</i>	136-139
<i>Briquetting Plants.....</i>	140-143
<i>Peat Briquettes.....</i>	144-148
1. Nature of the Bog.....	144
2. Price of the Raw Material.....	144-146
3. Steam or Fuel Consumption for Drying.....	146
4. Labour Cost.....	147
5. Cost of Plant.....	147
6. Total Cost of Manufacture.....	147
7. Competition with other Fuels.....	147-148
<i>Canadian Peat Briquette Manufacture.....</i>	148-157
The Welland Plant.....	148-150
The Beaverton Plant.....	150-157

	PAGE.
<i>Manufacture of Briquettes Without Air Drying the Peat.</i>	157-170
Drying by Pressure.....	157
Drying by Heat.....	157
Kerrinne's Method of Drying Peat by Means of Electric Energy.....	157-159
Electro Peat Coal.....	159-160
The Ekenberg Wet Carbonizing Process.....	160-170

## CHAPTER V.

PEAT POWDER.....	171-172
------------------	---------

## CHAPTER VI.

PEAT COKE.....	173-190
<i>Coking in Heaps</i> .....	173
<i>Coking in Ovens</i> .....	173-176
The Hahnemann Oven.....	173-174
The Wagenmann Oven.....	174-175
The Lottmann Oven.....	175-176
<i>M. Ziegler's Peat Coking Process</i> .....	176-188
The Oldenburg Plant.....	179-181
The Redkino Plant.....	181-183
The Beuerberg Plant.....	183-185
<i>Bammé's Peat Coking Oven</i> .....	188
<i>The Sahlstrom Process</i> .....	188-189
<i>Schöning &amp; Fritz Process</i> .....	189-190

## CHAPTER VII.

USES OF PEAT FUEL FOR HEATING, STEAM RAISING AND POWER PURPOSES.....	191-229
<i>For Domestic Purposes</i> .....	191-192
FOR STEAM RAISING.....	192-200
I. <i>Plane Grates</i> .....	192-193
Air Dried Peat as Locomotive Fuel.....	193-194
II. <i>Step Grates</i> .....	195-196
III. <i>Half Gas Furnaces</i> .....	197-198
IV. <i>Peat Powder</i> .....	198-200

	PAGE.
PEAT GAS. . . . .	200-229
<i>a. Peat Gas for Heating Purposes.</i> . . . . .	201-206
For Boiler Firing. . . . .	203
In the Iron and Steel Industry. . . . .	203-206
For Brick and Lime Manufacture. . . . .	206
For Glass Manufacture. . . . .	206
<i>b. Power Gas.</i> . . . . .	206-229
PRODUCERS FOR NON-BITUMINOUS FUELS. . . . .	208-215
Dowson Plants. . . . .	208-211
Bénier Plants. . . . .	211-212
Taylor Plants. . . . .	212-214
Pintsch Plants. . . . .	214
Körting Plants. . . . .	214
PRODUCERS FOR BITUMINOUS FUELS. . . . .	215-219
The Mond Producer. . . . .	216
Körting's Lignite Briquette Producer. . . . .	216-219
<i>Peat Gas Producers.</i> . . . . .	219-229
Körting's Producer. . . . .	220
Skabersjö Peat Gas Power Plant. . . . .	220-222
Burängsberg Peat Gas Power Plant. . . . .	223-224
Pintsch's Producer. . . . .	224-225
Luther's Producer. . . . .	225
Ziegler's Producer. . . . .	225-226
Frank & Caro's Producer. . . . .	226-227
Riché's Producer. . . . .	227-229

## CHAPTER VIII.

MANUFACTURE OF MOSS LITTER AND PEAT MULL. . . . .	230-240
<i>Manufacture of Moss Litter on a Small Scale.</i> . . . . .	230-231
<i>Manufacture of Moss Litter and Peat Mull on a Large Scale.</i> . . . . .	231-240
Tearing Machines or Disintegrators. . . . .	231-232
Peat Mull Mills. . . . .	232-234
Presses. . . . .	233-236
Description of the Moss Litter Plant at Yxenhult. . . . .	233-239
<i>Properties of Moss Litter.</i> . . . . .	240

## CHAPTER IX.

	PAGE.
USES OF MOSS LITTER AND PEAT MULL AND OTHER PEAT PRODUCTS . .	241-245
<i>Moss Litter for Bedding Purposes</i> . . . . .	241
<i>Moss Litter for Insulation and Packing Purposes</i> . . . . .	241-242
<i>Manufacture of Alcohol from Moss Litter</i> . . . . .	242
<i>Peat Mull for Sanitary Purposes</i> . . . . .	243
<i>Peat Mull for Packing Purposes</i> . . . . .	243
<i>Peat Molasses</i> . . . . .	243
<i>Manufacture of Peat Paper</i> . . . . .	243-244
<i>Other Peat Products</i> . . . . .	244-245
Textile Peat . . . . .	244-245
Peat Wood . . . . .	245
GENERAL CONCLUSIONS . . . . .	246-247



## INTRODUCTION.

Canada, like all northern countries, possesses large areas of peat bogs, which are distributed practically all over the country. The following table, obtained from the bulletin on peat by Dr. R. Chalmers, of the Geological Survey of Canada, gives a summary of the peat areas in Canada and the average depths of the bogs. East of Lake Superior the figures are at least approximately correct; west of that they are largely estimated.

Province of	Square miles.	Average depth in feet.
Nova Scotia . . . . .	250	8 to 10
Prince Edward Island . . . . .	10	"
New Brunswick . . . . .	250	"
Quebec (in settled parts) . . . . .	500	"
Ontario (in settled parts) . . . . .	450	5 to 8
Ontario (Moose River Basin, etc.) . . . . .	10,000	
Manitoba . . . . .	500	6 to 10
Alberta, Saskatchewan and Territories . . . . .	25,000	5 to 10
British Columbia and Yukon Territory . . . . .	no data	.....
Total in round numbers . . . . .	37,000	

Dr. Chalmers states, however, that the above figures are undoubtedly too low, as up to the present time no systematic investigation of the peat bogs has been undertaken, and most likely many bogs have not been recorded and included in the above estimate. It is evident, however, that the bogs in Canada cover an enormous area, which at present has been very little utilized either for fuel manufacture, agriculture or reforestation.

The area of the peat bogs suitable for the manufacture of fuel and other peat products or for agricultural purposes can, therefore, at the present time not be estimated, but considering the similarity of the peat bogs in Canada with those of northern Europe it is reasonable to assume that a large percentage of the Canadian bogs will prove suitable for either of these purposes.

An idea of the immense amount of fuel contained in the peat bogs can be had from the following calculation:—one cubic yard of a drained and settled bog gives at least about 250 lbs. of air dried peat, containing about

25% moisture. A bog with an average depth of six feet after drainage contains, therefore, per acre 1,210 tons\* air dried peat, and per square mile 774,400 tons, equal in fuel value to 430,244 tons of ordinary coal, assuming that one ton of coal is equivalent to 1.8 tons air dried peat, which has generally been found to be the case.

In many cases the average depths of the bogs are considerably greater than 6 feet, and a correspondingly increased quantity has to be added.

The increasing population and industrial activity in Canada, demanding every year a larger amount of fuel, the growing scarcity of wood in the settled parts of the country and the increasing prices of both wood and coal are making the utilization of our peat bogs a question of great importance. Several other reasons can also be added. The coal deposits in Canada are situated in the east and westerly provinces, leaving the interior provinces practically dependent on the coal mines of the United States, the disadvantage of which was strongly felt a few years ago, when, on account of the strike at these mines, the available coal supply was seriously curtailed and enormous prices had to be paid.

The saving to the country if at least a part of the imported fuel could be substituted by a home product is manifest from the following tables:†

#### IMPORTS AND VALUE OF

Fiscal Year.	Bituminous Coal.		Anthracite.		Coal Dust.	
	Tons.	Value.	Tons.	Value.	Tons.	Value.
1896.....	1,538,489	3,299,025	1,574,355	5,667,096	210,386	53,742
1897.....	1,543,476	3,254,217	1,457,295	5,695,168	225,562	59,609
1898.....	1,684,024	3,179,595	1,460,701	5,874,685	229,445	45,556
1899.....	2,171,358	3,691,946	1,745,460	6,490,509	276,547	44,717
1900.....	2,439,764	4,310,964	1,654,401	6,602,912	330,174	98,349
1901.....	2,516,392	4,956,025	1,933,283	7,923,950	414,438	275,559
1902.....	3,047,392	5,712,058	1,652,451	7,021,939	489,548	264,550
1903.....	3,511,412	7,776,717	1,456,713	7,028,664	550,883	420,317
1904.....	4,053,900	9,108,208	2,275,018	10,461,223	608,041	544,123
1905.....	4,176,274	8,002,896	2,604,137	12,093,371	650,261	343,456
1906.....	4,495,550	8,360,349	2,200,863	10,304,303	747,251	489,180

The quantity imported is steadily increasing, notwithstanding the increase in Canadian coal production, indicating the impossibility of supplying the interior provinces with coal from the east and westerly provinces on account of the heavy transportation charges.

The values of the imported coal given in this table represent only the amounts for which duty has to be paid, if dutiable, and not the price which consumers have to pay.

\* 1 ton=2,000 lbs.

† Compiled formerly by the Section of Mines of the Geological Survey Department, and at present by the Mines Branch of the Department of Mines.

## CONSUMPTION OF COAL IN CANADA.

Calendar Year.	Canadian Tons.	Imported Tons.	Total Tons.	Percentage Canadian.	Percentage Imported.	Consumption per Capita. Tons.
1896. . . .	2,639,055	3,206,456	5,845,511	45.1	54.9	1.140
1897. . . .	2,799,977	3,124,485	5,924,462	47.3	52.7	1.143
1898. . . .	3,023,079	3,274,981	6,298,060	48.0	52.0	1.200
1899. . . .	3,631,882	4,092,361	7,724,243	47.0	53.0	1.454
1900. . . .	3,989,542	4,361,563	8,351,105	47.8	52.2	1.561
1901. . . .	4,912,664	4,810,213	9,722,877	50.5	49.5	1.810
1902. . . .	5,376,413	5,165,938	10,542,351	51.0	49.0	1.927
1903. . . .	6,005,735	5,491,870	11,507,605	52.2	47.8	2.055
1904. . . .	6,697,183	6,909,651	13,606,834	49.2	50.8	2.346
1905. . . .	7,032,661	7,343,880	14,376,541	48.9	51.1	2.396
1906. . . .	7,927,560	7,398,906	15,326,466	51.7	48.3	2.425

The consumption per capita, due to increasing industrial activity and growing scarcity of wood, has doubled in the last ten years and will undoubtedly continue to increase. The percentage of imported coal shows only a very slight falling off, due to the reason previously stated.

The principal fuel for a large percentage of the population is, however, still wood. The amount used is difficult to estimate, but assuming, in order to arrive at an approximate figure, that about half the population, or some three million people, use wood for fuel at an average of  $2\frac{1}{2}$  cords per capita, the total amount would be  $7\frac{1}{2}$  million cords. The cost of a cord of wood is at the present time on an average probably not less than \$2.00, and the fuel bill in such a case is some 15 million dollars.

The growing value of the forests for other purposes, such as for lumber, pulp and paper mills, adds another reason for the development of our peat resources, especially as peat for fuel purposes is fully comparable and even superior to wood.

Several attempts have been made in Canada to manufacture peat fuel, but in most cases the results have been financial failures, which have caused a certain distrust among capitalists and the general public in everything connected with peat and the utilization of the peat bogs. The cause of these failures has, in some cases at least, been due to lack of knowledge of the peculiar properties of peat and the attempts in most cases have never passed the experimental stage, very little peat fuel having been placed on the market. The importance of the fuel question is so evident, however, that every effort should be made to bring about a successful utilization of our peat bogs.

In several European countries peat fuel and other peat products have been manufactured on an economical basis for a long time and used both for domestic and industrial purposes. The writer was therefore commissioned to proceed to these countries to investigate and report on the processes and machinery used and collect such other information as would be of value for Canadian conditions.

The European countries where peat fuel is used to a considerable extent are: Sweden, Norway, Denmark, Finland, Russia, Germany, Austria, Holland and Ireland. In most of these countries large industries for the manufacture of moss litter and peat mull are also established, and the consumption of these articles for bedding and packing purposes is rapidly increasing. The manufacture of peat coke is, especially in Germany, receiving much attention, and in Sweden several power plants with peat gas producers are in successful operation.

The methods at present used for peat fuel manufacture depend on air drying, which has been found, notwithstanding its uncertainty, to be the cheapest and most practical method of drying. The question of economically removing the water from the peat substance is the main problem, and a great number of more or less impracticable methods have been tried in Europe and much money lost, but the question of successfully utilizing the peat bogs is being steadily carried forward by means of new inventions and labour saving appliances. The interest displayed by the various governments and assistance given in some form or other has also had a stimulating influence on the peat industries in these countries. In the countries mentioned, with the exception of Russia, Holland and Ireland, societies receiving yearly grants from their respective governments have been organized for the purpose of giving information and advice regarding the manufacture of peat products and the cultivation and drainage of peat bogs. These societies, through publications, lectures and experimentation, do a very valuable educational work, assist manufacturers and farmers with investigations and advice and also do a great amount of good by criticising the processes and methods invented from time to time, which in many cases prevents the useless spending of money.

On account of the large population in Europe, land is naturally more expensive than in Canada at the present time, and the question of cultivating peat bogs in Canada will probably for some time to come be of minor importance, although in certain instances such cultivation would even now undoubtedly be a paying proposition. In the United States the reclamation of bog and swamp lands for agricultural purposes and reforestation is receiving much attention and several large drainage projects are at present under consideration. The increased value of such drained land, which in its original state is practically valueless, would in more populated sections of Canada probably pay the cost of such undertaking just as well as the irrigation projects carried on in sections where water is lacking. Furthermore, the beneficial results in climatic conditions due to proper drainage are points worthy of attention.

The European governments are generally assisting in such drainage works when large areas are affected, and thereby also assist incidentally the peat industry in those localities, as the drainage of a bog in many cases involves a heavy expenditure for which no immediate returns can be expected.

A detailed account of the assistance given the peat industry by the different European governments is hereafter given.

#### SWEDEN.

The coal production in Sweden is insignificant, and the coal mined is of inferior quality. This country is, therefore, practically dependent on foreign nations for its supply of coal. The question of utilizing the peat bogs, which occur in abundance, has therefore in later years received much attention from the government, and the manufacture of peat fuel, moss litter and peat mull is steadily growing.

The government now employs one chief engineer, one engineer and two assistant engineers under the direction of the Department of Agriculture. The duty of these engineers is to investigate and report on all new processes referring to the peat industry, to assist manufacturers with plans and investigations of peat bogs and to advise the Government on the advisability of giving loans for the erection or enlargement of peat plants or assistance to inventors of promising processes in order to enable them to carry on experimentation.

The Swedish parliament in 1901 voted 100,000 kronor\* to be used for the encouragement of the peat industry, and in 1902 a fund of 1,500,000 kronor was established, from which loans on liberal terms are given to peat manufacturers. This fund was in 1907 further increased with 2,000,000 kronor.

In order to find out the possibilities of manufacturing peat fuel in the northern part of the country, where the summer is short and drying conditions consequently less favourable, an experimental plant was erected at Koskivara, situated at a latitude of 66° 39'. The results, which are referred to later, were quite satisfactory. The Government has also undertaken to make official tests with peat machinery in order to find out the most suitable machinery and methods. Two such tests have so far been made in 1903 and 1907 and the results published by the Department of Agriculture.

The peat society "Svenska Mosskulturföreningen" in Jönköping receives a yearly grant of 20,000 kronor from the Government and additional grants from the municipal boards.

The peat school, established at Markaryd under the direction of Mr. A. Anrep, receives a yearly grant of 7,000 kronor. The object of this school is to train and educate foremen and superintendents for peat plants.

In large drainage works, which can benefit a greater area, the government, as well as the municipalities concerned, generally assist with a part of the cost.

In 1900-1901 a commission of two engineers was appointed to study the peat industry in Europe, and the report† of this commission, which has been freely used by the writer, was published in 1902.

\* 1 Krona=27 cents.

† Om brännrotindustrien i Europa, by Alf. Larson and Ernst Wallgren.

## NORWAY.

This country possesses no coal deposits and the peat question is, therefore, of great importance. The government employs one engineer, who in 1901 was sent out to study the peat industry in Europe and Canada.\*

The peat society "Det Norske Myrselskab" in Christiania receives a yearly grant of 8,000 kroner.

## DENMARK.

This country possesses no coal deposits and very few forests. The use of peat fuel has, therefore, been introduced, and on account of favourable drying conditions and suitable methods of manufacture the peat industry in Denmark is on a good economical basis.

The society "Hedeselskabet" in Aarhus received in 1901, 76,500 kroner and "Moseselskabet" (formerly Moseindustriforeningen) receives a yearly grant of 8,000 kroner.

## FINLAND

This country possesses no coal deposits, but wood is still fairly abundant and cheap. Peat fuel manufacture has so far not reached any magnitude, but the consumption is slowly increasing. The society "Finska Mosskulturföreningen" in Helsingfors receives a yearly grant of 36,500 f. marks† and employs one special engineer for investigation of peat fuel manufacture and its possibilities.

## RUSSIA.

Russia has the largest peat industry in the world, with some 1,300 machine peat plants in operation. The government itself owns and operates a number of such plants and also a large peat coking plant erected at Redkino at a cost of 1½ million marks.‡

A committee presided over by the Minister of Agriculture decided in 1900 that:

1. Private persons should be allowed to work peat bogs owned by the government.
2. Assistance should be given for investigations of the peat bogs.
3. Instructions in the simplest methods of working the peat bogs and in the use of peat products should be given to peasants.
4. Assistance should be given to facilitate the transportation of peat.
5. The railway tariff for peat should be lowered.
6. A fund should be established from which peat manufacturers could obtain loans on easy terms.

\* Torvdrift in Kanada m. fl. lande, by J. G. Thaulow.

† 1 f. mark=19.5 cents.

‡ 1 mark=24 cents.

7. Peasants should be allowed to work peat bogs owned by the government, paying a yearly rent of 0.45-0.90 cents per square yard.

The Russian government, especially from a military point of view, is anxious to make Russia independent of imported fuel and gives, therefore, to private persons or companies erecting peat plants in Russia a loan of 40% of the cost of the plant. This loan can be paid back in peat products. It is also stipulated that manufacturers of machine formed peat may have their peat coked at the government plants at a cost of \$1.37 per ton peat coke. The government buys, if desired, this coke at a price calculated on the basis of the fuel value of Newcastle coal at \$4.42 per ton, so that the peat coke is paid more or less according as it is inferior or superior in fuel value to this standard. The production of peat fuel in Russia was some four million tons in 1902, and it is yearly increasing.

#### GERMANY.

In Germany the peat question is of less importance, on account of the coal and lignite resources, but in certain parts of this country a very extensive peat industry has been established, and much credit is due several German inventors of machinery and processes for the utilization of the peat bogs. The German government operates several experimental farms for moor cultivation and gives a yearly grant to the society "Verein zur Förderung der Moorkultur im Deutschen Reiche" in Berlin. In certain districts the railroads have a special tariff for peat and lignite, and in other districts canals have been built and cheap freights thereby made possible.

#### AUSTRIA.

The experimental farm at Vienna has had since 1901 a special branch for moor cultivation and peat manufacture. Other experimental farms are established at Sebastianberg, Laibach, Klagenfurt, Admont, Sterzing, etc., where free education is given in moor cultivation and peat manufacture. The society "Deutsch-Österreichische Moorverein" has its headquarters at Staab bei Pilsen.

#### HOLLAND.

In Holland peat fuel has been used for centuries, and at present the production is over one million tons per year. The worked out peat bogs are excellent for agricultural purposes and annually about 1,000 acres of such land are gained.

During the last fifty years some 250 miles of shipping canals and 500 miles of moor canals have been built. The cost of these canals has been \$4,800,000, and for maintenance and improvement of older canals a further sum of \$4,480,000 has been spent. The government has contributed to these works \$2,891,600, and the provinces \$4,369,200. In order to be inde-

pendent of foreign nations for fuel the government has always a certain amount of peat fuel stored for military purposes in case of war, and also uses peat fuel in its buildings.

The cost of peat fuel in Holland is considerably higher than that of coal, which can be cheaply imported from England and Germany, but notwithstanding this fact, peat is largely used for domestic purposes.

#### IRELAND.

In Ireland the Department of Agriculture and Technical education is encouraging the peat industry by giving assistance with investigations of bogs and information regarding new methods and use of peat products.



## CHAPTER I.

## ORIGIN, OCCURRENCE, CLASSIFICATION AND USES OF PEAT.

Peat is a combustible substance produced under certain conditions by the slow decay of vegetable matter. The character of peat depends upon the conditions prevailing during this decay and on the nature of the vegetation from which it is formed. To the peat forming vegetation belong nearly all the mosses (especially *Sphagnum* and *Hypnum*), heath plants, sea and swamp plants such as rushes, sedges and grasses, trunks and roots of trees, leaves, etc.

According to P. R. Björling and F. T. Gissing\* the peat formation is accounted for in the following manner:

“During the growth of the plants the interior walls of the cells are gradually coated with matters, which ultimately become so thick as to impede the free transpiration of oxygen and aqueous vapour, the result of which is a lowered vitality and finally death of the cell. At this stage the plant generally begins to decompose, the contents of the cell disappearing first, then the cell wall, and lastly the spiral fibres. These steps are marked by characteristic chemical changes. The retention of oxygen in the compounds at the time of death promotes fermentation, especially of the nitrogenous substances which yield ammonia, sulphuretted hydrogen and phosphuretted hydrogen. The non-nitrogenous substances, such as the sugars and starches, are converted into the various acids generally yielded by decaying vegetable matter. In course of time the cells become so distended with the products of decomposition that their walls burst and the various gaseous compounds escape. With this new condition of things the further chemical changes assume a different character and the still unaltered vegetable matter is converted into humic and allied acids and carbonic acid, while the soluble compounds slowly pass away in solution. The final result is that the cell is emptied of its contents and deprived of its green colour if it originally contained chlorophyll. The next stage consists of the decomposition of the cell wall, which proceeds more or less rapidly, according as it is or is not incrustated with sparingly soluble lime salts, silicates and resinous matters, and according to the strength of the vegetable acid solutions in which it is immersed. By the evolution of oxygen, aqueous vapour and carbon dioxide there results a mass which contains a large and increased proportion of carbon, a little hydrogen and a little oxygen in a combined form, generally as a yellow-brown ulmin, but often this is subsequently converted by oxidation into the light brown humin. At this stage the vegetable matter is mainly a mixture of ulmin, humin and spiral fibres. The last stage, the destruction of the

\* Peat, its use and manufacture.

spiral fibres and more resistant tissue, is much assisted by the combined action of frost and moisture. Frost disintegrates the fibres and the black mould-like substance absorbs so much water that it becomes water-logged and sinks to the bottom of the pool or liquid which it is in. With the accumulation of this matter it becomes subjected to pressure, to slow carbonisation, and to permeation by bituminous and resinous substances, and after a time becomes what is known as peat."

In order that the process may proceed as above outlined free access of air must be excluded, otherwise the residue will be gradually oxidized and only the inorganic ingredients left.

In the case of a peat bog, however, the material is immersed in water and the free access of air excluded, resulting as above outlined in the gradual accumulation of peat, which becomes richer in carbon contents at a rate depending on the rapidity of the humification process. The older the peat is, the better humified or riper it generally is, dependent, however, on the vegetation forming the different peat layers. In many cases the vegetation on one and the same bog has changed from time to time, probably depending on different heights of the water level, and in such cases poorly humified layers of peat derived from a vegetation more resistant to humification than the previous or later vegetation can be found imbedded in a bog with otherwise well ripened peat. As a rule, however, the upper layers of a growing peat bog, consequently of younger age, are less humified than the deeper layers. They have a comparatively light colour, small specific gravity and low fuel value. The deeper layers and older peat bogs generally contain a brown to black, heavy and well humified peat, and the deepest layer a brownish black, dense peat, containing very little of still recognisable vegetable remains, and which has the highest fuel value.

In many peat bogs a bottom layer of earthy black material is found, which contains no recognisable vegetable remains and when dried crumbles to pieces.

"The formation of peat is dependent upon a special combination of climatic and topographical conditions. The principal factors are:

1. Growth of aquatic and moisture loving plants.
2. A soil or sub-soil which will retain water at the surface.
3. Sufficiently humid atmosphere to prevent too rapid evaporation.
4. A temperature high enough to allow a profuse growth of vegetation, yet low enough to check too rapid a decay of vegetable matter.

Bogs generally occur in shallow depressions having a clay bottom, or when the water rests on permeable matter like sand this overlies an impermeable sub-soil. The water must be still, but not stagnant nor subject to the influence of rapid currents of water. Hence, the bogs generally originate in a lacustrine area, which gradually becomes filled up with silt and aquatic plants and so becomes fitted for the vegetation characteristic of peat. As a consequence of this, bogs are most prevalent in lowland districts, but they

may occur in mountainous country when drainage is impeded so as to form local accumulations of water.

Humidity is a very important regulator of the distribution of bogs. Wooded moors favour the growth of mosses, owing to the air there being more moist than in the open country. Hence it is that the bogs in low-lying areas seldom have trees buried in them, whereas in mountain bogs trees are plentiful, the growth of the moss being favoured by the fallen trunks damming back the water so as to form pools."

The peat bogs are generally classified as high bogs (Hochmoore) and low bogs (Niederungsmoore).

*High Bogs.*—The vegetable matter forming these bogs is principally made up of the remains of mosses, heath plants and of forest residue. On account of the moisture absorbing property of the sphagna in particular, these bogs are like enormous sponges, retaining large quantities of water, which furthermore favours the growth of this vegetation. Under favourable conditions these bogs may attain considerable depth, especially in their central parts, where the drainage is less and the growth of the moss more profuse. In many instances these parts are on a higher level than the rest of the bog and often from 15 to 50 feet or more in depth.

*Low Bogs.*—The vegetable matter forming these bogs is made up of the remains of plants requiring more nourishment than the plants forming the vegetation of a high bog. The principal vegetation on low bogs is grasses, sedges, reeds and rushes. Low bogs chiefly occur in localities which are occasionally or periodically flooded.

In a great number of cases the conditions under which a bog has been formed have changed from time to time, resulting in different vegetation and in peat of different qualities. Bogs of this nature are classified as mixed bogs (Übergangsmoore or Mishmoore.)

The different classes of peat are divided into two large groups\* :—I, moss peat, and II, grass peat, each of which is subdivided into smaller groups.

## I. MOSS PEAT.

This group is subdivided into three smaller groups:

*a. Sphagnum Peat.*—The porous character of the sphagna and its composition, which practically consists of cellulose with only a small percentage of albumen, makes the sphagnum peat very resistant to humification. It contains a very small amount of inorganic substances, growing as it does on ground and water containing little nourishment, and gives, therefore, when burnt very little ash. Well humified, it has fairly good cohesion and produces a good fuel, which, however, is comparatively light and porous and under unfavourable weather conditions requires longer time for drying than a fuel made from a more compact peat. The weight per unit of volume is con-

\* Lecture by J. Hallmén, Markaryd, Sweden.

siderably increased by an intensive pulping process, which also improves the drying conditions, as later explained.

The sphagnum moss and partially humified sphagnum peat are largely used as raw materials in the moss litter industry and have been or are used to some extent for the manufacture of paper, building, filling, packing and insulation materials, for medical use and for the manufacture of alcohol.

*b. Hypnum Peat.*—The hypnum moss requires lime and occurs, therefore, on limy ground or where the water contains lime. Contrary to the sphagnum the hypnum has thick walled cells without pores or spiral cells and lacks the great moisture absorbing property of the former.

It humifies slowly, has high contents of ash, 8-30%, very poor plasticity, and when dried and handled goes very easily to pieces. Only when well humified and mixed with the remains of other plants, with lower contents of ash, is it suitable for fuel manufacture.

The hypnum bogs are rich in nitrogen, lime and other nourishment, and are, therefore, as a rule well adapted for agricultural purposes.

*c. Forest Moss Peat.*—This class of peat is formed by mosses, heath plants and the residue of forests. Trunks and roots of trees are generally plentiful, but with the exception of pine these remains are, as a rule, decayed, soft and easily pulped in a suitable peat machine.

The peat, on account of the great variety of plants from which it is formed, is easily humified, but generally has little cohesion. This is improved by a thorough mixing and pulping process. The content of ash is from 5 to 8 %.

When well humified and properly treated it gives a good fuel of comparatively high fuel value. Part of the vegetation forming these bogs is always made up of sphagnum and on limy ground by hypnum, in which latter case the peat contains a comparatively large amount of lime. It is always rich in nitrogen, and under these conditions suitable for agricultural purposes.

## II.—GRASS PEAT.

This group is sub-divided into three or more smaller groups:

*a. Sea Peat.*—This peat is principally formed by the remains of such plants as phragmites, scirpus and equisetum, often mixed with the remains of menyanthes, nymphæa, etc. It is easily humified, but always contains fragments of roots not humified. Generally it is mixed with the remains of fishes and birds and contains considerable amounts of nitrogen, lime and other inorganic substances. The content of ash is from 8 to 10%. When well humified, it is a soft plastic mass, from which a heavy and compact peat fuel is obtained.

*b. Carex Peat.*—Peat of this class is formed by the remains of the large variety of plants belonging to the Carex family, generally mixed with the remains of mosses and other plants. The composition is very variable. In

some cases a heavy, dark and compact peat fuel may be obtained, but in other cases the peat is porous, light and of little cohesion. The content of ash is also variable and depends on local conditions, such as floods, when silt and sand are deposited, in which case the content of ash is very high. As a rule these bogs are well suitable for agricultural purposes, but for fuel manufacture only when the content of ash, which varies from 3 to 25%, is low.

*c. Eriophorum Peat.*—Peat formed principally from the remains of this plant is the best raw material for the manufacture of peat fuel. When well humified, it gives a black, heavy and compact fuel, drying comparatively rapid and containing a low percentage of ash, 0.75-4%.

Less humified peat of this kind has been used for the manufacture of different fabrics, on account of its strong fibres, but neither the products nor the economical results seem to have proven satisfactory.

## CHAPTER II.

## COMPOSITION AND CALORIFIC VALUE OF PEAT.

A drained peat bog still contains large quantities of water and, as a rule, only 10 to 15% of dry peat substance. The raw peat is therefore air dried and contains after such drying, if properly conducted, from 15 to 25% moisture. In many cases a higher content of moisture is found, but if the peat is to be used as a fuel for ordinary purposes the moisture should not be allowed to exceed a limit of 25-30%, especially if used for domestic purposes.

The following table\* published by Prof. Klason, of Stockholm, Sweden, gives the average composition of different kinds of fuel, together with the mean calorific value of the absolutely dry and ash free fuel and the average percentage of moisture in its air dried state.

Composition.	Wood.	Peat.	Lignite.	Swedish Coal.	English Steam Coal.
Carbon.....	52.0	58.0	66.0	78.0	81.0
Hydrogen.....	6.2	5.7	4.6	5.1	5.2
Oxygen.....	41.7	35.0	28.0	14.8	11.5
Sulphur.....	....	....	....	0.8	1.0
Nitrogen.....	0.1	1.2	1.0	1.3	1.3
Calories†.....	4900	5700	6000	7500	8000
Moisture.....	20.0	22.0	25.0	13.5	7.6

The content of ash is variable and is considered low if less than 5%, and high if more than 8% of an absolutely dry sample.

\* Teknisk Tidskrift, 1896.

† 1 cal.=the heat required to raise the temperature of 1 kg. (2.2 lbs.) of water 1° Centigrade (1.8° F.)

The following scale\* is used by the government engineers in Sweden for comparison of the different qualities of absolutely dry peat:—

Fuel value. . . . .	Very high	High	Average	Low	Very low
Cal. per kg. about. . . . .	5600	5300	5000	4700	4400
B.T.U. per lb. about. . . . .	10080	9540	9000	8460	7920
Contents of ash	low	average	comparatively high	high	very high
% about . . . . .	2	5	8	11	14
Absorbing property	very high	high	average	low	very low
% about . . . . .	1900	1600	1300	1000	700

### Analyses of Peat.

For common purposes the contents of ash, moisture, combustible or organic substance and the calorific value of a peat fuel are the most important determinations and in most cases sufficient. If the peat is used for metallurgical purposes (peat coke) the contents of sulphur and phosphorus are of importance, and in other cases the content of nitrogen should also be ascertained.

The following table gives the chemical composition of the dry peat substance from bogs in different localities:—

Peat from	100 Parts Dry Peat Contains					Moisture in the air dried peat
	Carbon	Hydrogen	Nitrogen	Oxygen	Ash	
Cappoge,† Ireland . . .	51.05	6.85	39.55		2.55	10.0
Kulbeggen, " . . .	61.04	6.67	30.46		1.83	.....
Philipstown, " . . .	58.69	6.97	1.45	32.88	1.99	.....
Rammstein, Germany	62.15	6.29	1.66	27.20	2.70	16.7
Niedermoor, " . . .	47.90	5.80		42.80	3.50	17.0
Bremen, " . . .	57.84	5.85	0.95	32.76	2.60	.....
Schopfloch, " . . .	53.59	5.60	2.71	30.32	8.10	20.0
Grunewald, " . . .	49.88	6.50	1.16	42.42	3.72	.....
Haspelmoor, " . . .	58.93	5.72		35.35	8.43	15.50
Kolbermoor, " . . .	58.51	6.17		35.32	4.21	15.50
Holland. . . . .	50.85	4.64		30.25	14.25	.....
Sweden† . . . . .	54.13	6.45		39.42	1.89	.....
" . . . . .	54.56	5.95		39.49	3.08	.....
" . . . . .	53.34	5.70		40.96	1.78	.....
" . . . . .	55.33	5.31		39.36	9.97	.....
" . . . . .	57.14	5.95		36.91	7.10	.....
" . . . . .	58.26	5.73		36.01	8.69	.....

\* Torftjänstemännens verksamhet, 1905.

† Hausding, Handbuch der Torfgewinnung.

‡ Svenska mosskulturforeningens tidskrift, May, 1905.

The following tables give some results of the determinations usually made for commercial purposes.

Peat Fuel from Sweden.*	COMPOSITION.				CALORIFIC VALUE. CALORIES PER KG.			Weight per unit of volume with its percentage of moisture. (Relative spec. weight).
	Moisture. %	Ash. %	Combustible substance. %	Ash in dried sample. %	Of dried and ash free sample.	Of dried sample.	Of original sample (with its percentage of moisture.)	
Koskivara.....	28.34	4.21	67.45	5.87	5622	5292	3414	0.61
Enköping.....	23.38	7.28	69.34	9.50	5260	4759	3298	0.61
Fagersanna.....	25.27	1.74	72.99	2.33	5525	5394	3656	0.67
“.....	20.21	2.78	77.01	3.48	5475	5284	3858	0.53
Stafsjö.....	22.45	1.96	75.59	2.53	5481	5342	3775	0.73
“.....	24.63	2.12	73.25	2.81	5906	5740	3950	0.69
Löberöd.....	29.83	2.52	67.59	3.68	5421	5221	3277	0.87
Vestra Torup.....	26.16	4.04	69.80	5.47	5837	5518	3702	0.70
Yxenhult.....	34.02	2.50	63.48	3.79	5687	5443	3194	0.80
“.....	36.68	3.55	59.77	5.61	5784	5459	3053	0.64
Emmaljunga.....	25.54	4.32	70.14	5.80	5858	5519	3740	0.80
Granefors.....	20.01	5.98	74.01	7.48	5601	5181	3797	0.67

\* Svenska mosskulturforeningens tidskrift, Jan., 1905.



The average composition of 57 samples was:

Moisture .....	27.17%
Ash .....	3.27 "
Combustible substance .....	69.56 "

The calorific value of the original samples (with its contents of moisture) varied between 2,235–4,307 calories per kg., averaging 3,463 calories or 6,233 B.T.U. per lb.

The calorific value of the dried samples varied between 4,530–5,740, averaging 5,266 calories per kg. or 9,478 B. T. U. per lb.

Peat Fuel from Denmark.*	Ash. %	Sulphur. %	Nitrogen. %	Organic Substance. %	Moisture. %	Calorific value of sample with its percentage of moisture calories.
Bjornkaer.....	4.1	0.31	....	70.69	25.0	3730
Lyngen .....	8.0	0.30	....	66.70	"	3600
Korsor .....	10.8	1.80	1.2	62.40	"	3280
Axelvold.....	4.4	0.63	1.5	68.50	"	3574
Pindstrup .....	0.84	trace	0.72	74.10	"	3330
Okaer .....	8.10	....	....	66.90	"	3343
Sparkaer.....	5.00	....	....	70.00	"	3644
Herning.....	1.40	....	....	73.40	"	3582

The following table gives the composition of some Canadian peats analysed by the Bureau of Mines, Toronto, and by the Geological Survey Department, recalculated for comparison.

Peat from	Moisture. %	Ash. %	Combustible Substance. %
Welland .....	25.0	3.58	71.42
Perth .....	"	7.29	67.71
Brockville .....	"	8.20	66.80
Rondeau .....	"	7.03	67.97
Newington .....	"	0.92	74.08
Prince Edward Island .....	"	2.82	72.18
Ste. Thérèse.....	8.86	9.50	81.64

\* From Mosebladet, July, 1907.

## CHAPTER III.

## MANUFACTURE OF AIR DRIED PEAT FUEL.

The main problem in the manufacture of peat fuel is, as has already been stated, the removal of the water in an economical manner. A fully satisfactory solution of this problem has not yet been reached, as the methods\* so far employed on a larger scale depend on weather conditions for the drying of the wet peat. The season during which a peat bog can be worked is, therefore, comparatively short and varies from 90 to 115 days. This makes the labour question at least in some localities a difficult one. Great improvements have, however, been made in the methods used and new machinery and labour-saving appliances invented, which considerably decrease the number of men required, increase the production and deliver a peat fuel of better quality. The manufacture of peat fuel, where conditions are favourable, is, therefore, even now an undertaking which, if properly conducted, will leave a reasonable profit.

Numerous methods have been tried, involving the expenditure of large amounts of money, in attempts to remove the water by mechanical appliances or other artificial means, but most of these methods have failed entirely or proved unsatisfactory from an economical standpoint. No attempt will be made to describe all the methods tried or those which from time to time have been advertised as having solved the peat question; only those which at present are used to any extent or are of special promise or interest will be dealt with.

A drained and settled peat bog still contains from 85 to 90% moisture, and on account of the peculiar nature of peat in its natural state the contents of moisture cannot even in strong presses under enormous pressure be brought down to less than 60 to 70%, which has been demonstrated time and again. The cost of this process with the methods so far used in Europe is prohibitive, the production too small and the contents of moisture still left too high to allow a final drying by artificial heat.

Air dried peat fuel contains, on an average, 25% moisture; the peat manufactured during the early part of the summer, when drying conditions generally are more favourable, sometimes contains considerably less or from 15% and upwards, and that manufactured later sometimes a little more. This fuel as compared with coal is very bulky and, under ordinary conditions, does not stand heavy transportation charges. The bog should, therefore, be located comparatively close to a sufficient market. If, on the other hand,

\* The wet carbonizing process invented by Dr. M. Ekenberg and later described, is independent of weather conditions, but at present no commercial plant is in operation.

a peat fuel with increased fuel value per volume could be economically manufactured, either by briquetting, carbonizing and briquetting, coking, or as a powder, a fuel would be obtained which in many instances could favourably compete with coal.

Another way of utilizing the peat bogs on a larger scale is for the development of electric energy. The power plants should then be located at the bogs, when the bulkiness of the air dried peat fuel is of less consequence.

The methods at present employed on a large scale for the manufacture of air dried peat fuel are:

1. Cut peat, when the peat is cut out of the bog by hand or machinery and afterwards air dried, without undergoing any mechanical treatment.
2. Machine peat, when the raw peat after being dug out of the bog generally by hand is first subjected to mechanical treatment and afterwards air dried. The methods used for manufacturing machine peat are, as a rule, divided into two classes:
  - (a) when additional water is added to the peat mass in such quantities that the resulting peat porridge can be run out into moulds.
  - (b) when the peat mass is treated without additional water and has such consistence that it can be formed into desired shape without moulds. This latter class is properly termed machine formed peat, but is often called pressed peat.

#### GENERAL REQUIREMENTS FOR A SUCCESSFUL PEAT FUEL MANUFACTURE.

The first condition for a successful undertaking is a suitable peat bog, as free as possible from roots, trunks and stumps of trees, which interfere with continuous working. The peat should be well humified and have a low content of ash. A depth of 6 to 12 feet or more is desirable, especially when a large output is desired and machinery employed, otherwise a considerable area requires to be worked, which necessitates frequent movings of the machinery and transportation arrangements, entailing loss of time and increased cost.

A wet bog free from roots and trees can sometimes be cheaply worked by the employment of suitable machinery for digging the peat out of the bog, but as a rule a drained bog is more easily worked. Whenever roots and trees are plentiful the mechanical excavator is not suitable and such bogs require sufficient drainage. Good drainage facilities are, therefore, favourable.

In many cases it is not necessary to drain a bog to the bottom, but the surface must be well drained, in order that as solid ground as possible may be obtained for the workmen and animals to walk on, and the laying of tracks facilitated. Occasionally the water in a bog is dammed up during the winter in order to protect the peat from frost. Peat which has been frozen hard generally loses its cohesive properties and easily crumbles to pieces, making it less suitable for the manufacture of peat fuel. The bog should be carefully

levelled, whereby transportation is facilitated and a better shaped peat fuel obtained. Any reasonable amount spent on the drainage and levelling of the bog is, therefore, generally well spent and pays in the long run.

The drainage of the bog should be done at least one year previous to the beginning of manufacturing operations, in order to give the bog time to settle down. Experience has shown that when a newly drained bog containing peat of good quality gives per cubic yard about 200 lbs. of air dried peat with 25% moisture, the same bog after one year gives 250 lbs. and after two years 300 lbs. or more per cubic yard.

Trees preventing the free access of air and wind should be removed, as the effect of the wind on the drying of peat is of more importance than that of the sun.

The machinery and methods employed must be suitable for the bog. The bogs differ greatly as well as the local conditions and a machine or method which works satisfactorily in one bog may be found very unsatisfactory in another. A thorough investigation of the bog and the advice of a competent person is therefore desirable before operations are started. A capable superintendent or foreman, trained workmen and suitable machinery and transportation facilities are of great importance if the work is to proceed satisfactorily. Generally it is preferable to work by contracts, paying the men a fixed sum per 1,000 pieces of peat or per cubic unit of raw peat dug out of the bog.

#### PRELIMINARY WORK.

The first work to be undertaken after a bog in a suitable locality has been found is the investigation and sampling of same. The area is divided into squares with sides of 150-300 feet, and at each corner of these squares samples are taken from different depths. The instrument used for this purpose should be of such construction that samples can be taken from any desired depth without being mixed with material from any other depths. If the samples from the same depths are of uniform character they can be mixed together and a general sample made, but if they differ materially in composition or appearance separate analyses should be made. The content of ash generally increases with depth and in order to avoid the production of a fuel with high content of ash the composition of the different layers should be thoroughly investigated. The degree of humification as well as the cohesive properties of the peat should also be ascertained.

After the levels have been taken, profiles can be made showing the different layers of the peat and a proper plan for working the bog should then be made out. The next work, if the bog has proved to be suitable, is the drainage of same. The main drain is first dug and afterwards a ditch around the margin of the bog in order to drain away the surface water from the surrounding ground. Next in order comes the levelling and drainage of the drying field, which, as a rule, is the surface of the bog nearest the working trenches.

Good transportation arrangements are of great importance. A permanent track or aerial tramway is generally used from the bog to the store houses or loading station and on the bog itself light portable tracks are used.

### PUMPING MACHINERY.

A bog not sufficiently drained by ditches can in most cases easily be kept dry by pumping and where a thorough drainage would require the expenditure of a large amount of money it is probable that pumping will be cheaper. The height to which the water requires to be raised is generally small, permitting the use of very simple pumping machinery.

The pump mostly used is the water-screw shown in Fig. 1. This apparatus is of simple construction, has a high efficiency and is very suitable in bogs where the water, as a rule, is full of dirt, pieces of wood or other substances,

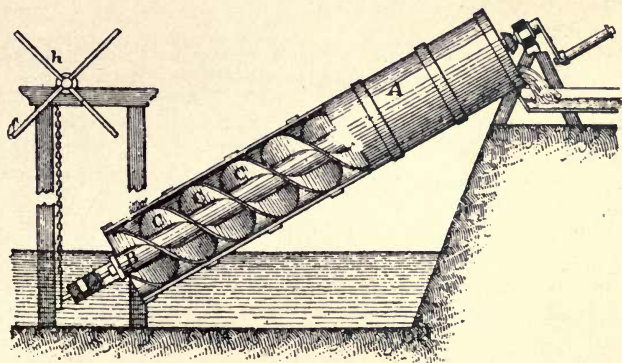


FIG. 1—Closed Water-screw.

which in other pumps would cause stoppages and repairs. The water-screw consists of a cylinder or half cylinder in which a screw rotates. An open screw can be used at an inclination up to about  $30^\circ$ , and a closed one up to  $45^\circ$ . In the former case it should make 70–80 revolutions per minute, and in the latter 40–50. The pitch is, as a rule, made the same as the outer diameter of the screw.

If only a small amount of water needs to be pumped, the water-screw is operated by hand, otherwise some mechanical arrangement is used. In many cases a windmill is quite suitable.

The following tables\* give the approximate pumping capacities and power required for different water-screws.

\* Hausding Handbuch der Torfgewinnung.

## CLOSED WATER-SCREW.

No.	Inside diameter of cylinder. inches.	Capacity per min. cubic feet.	Power required per 1 foot lifting height. h. p.
1 .....	14.4—15.2	19.42	0.06
2 .....	15.2—16.0	26.48	0.08
3 .....	16.0—17.2	31.78	0.10
4 .....	17.2—18.0	38.84	0.12
5 .....	18.0—18.4	46.61	0.13
8 .....	19.6—21.2	68.15	0.18
10 .....	21.6—22.4	83.33	0.23
12 .....	22.8—24.0	104.16	0.30
15 .....	26.0—27.2	141.24	0.40

## OPEN WATER-SCREW.

No.	Inside diam. of half cylinder. inches.	Capacity per min. at 50 revolutions. cubic feet.	Power required per 1 foot lifting height. h. p.
1 .....	20.4—24.0	88.27	0.30
2 .....	22.0—25.6	123.58	0.42
3 .....	25.6—28.0	190.67	0.54
4 .....	28.0—29.6	225.98	0.60
5 .....	29.6—31.6	282.48	0.80
6 .....	31.6—34.0	335.44	0.90
7 .....	34.0—35.2	388.41	1.06

Centrifugal pumps and pulsometers are occasionally used.

## METHODS OF MANUFACTURE.

## I. CUT PEAT.

The peat is cut out of the bog in brick-shaped blocks, which later are air dried. With the exception of the tools or machinery used for cutting the peat out of the bog, no mechanical arrangements are required.

The cut peat is, as a rule, porous,\* exceedingly bulky and more dependent on favourable weather conditions for drying than machine peat (see page 33).

\* The chief engineer of the firm R. Dolberg, in Rostock, Germany, made comparative tests with cut peat and machine peat from the same bog. The machine peat was made by a Dolberg machine. The raw peat contained in both cases 85% and the air-dried peat 20% moisture. A piece of the dimensions 200 x 100 x 100 mm. = 2 liters of the raw peat weighing 2 kg. contracted when dried to the dimensions 135 x 63 x 63 mm. = 0.535 liters, i.e., respectively 67.5, 63.0 and 63.0% of the original dimensions, or to 26.7% of the volume. Its weight with 20% moisture was 0.375 kg. = 18.5% of the original weight.

A piece of the machined peat of the same original dimensions contracted when dried to the dimensions 130 x 53 x 53 mm. = 0.365 liters, i.e., to respectively 65, 53 and 53% of the original dimensions, or to 18.3% of the volume. Its weight with 20% moisture was 0.375 kg. = 18.5% of the original weight. The specific weight of the cut peat was 0.7, and that of the machine peat 1.028.

It is, therefore, gradually being displaced by machine peat, except when used as a raw material for the peat briquetting industry, where cut peat is preferable on account of its porous nature.\*

### CUT PEAT DUG BY HAND.

This is the oldest and simplest manner of manufacture and has been used for centuries. It is still used to a great extent both in Ireland and on the Continent, especially by country people digging their own fuel supply or operating on a small scale. This method can be employed in every drained bog, irrespective of its depth or area; the degree of humification and the occurrences of roots and stumps, however, affect the cost of production.

The work is carried out in the following manner: The bog is first thoroughly drained; afterwards the drying field is levelled and drained by small ditches about one foot wide and 30 to 60 feet apart, as shown in Fig. 2.

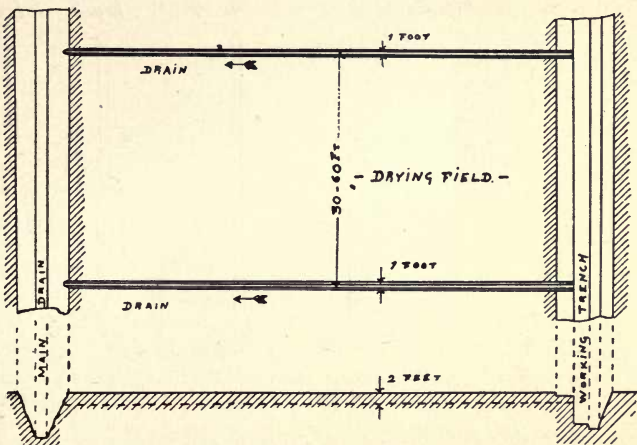


FIG. 2—Method of Drainage.

The surface of the bog is divided into squares, each of which generally is worked by two men, one man cutting the peat and placing it on the edge of the working trench, and the other loading it by hand or with a pitch fork on a wheel barrow or truck and transporting and laying it out on the drying field. In certain localities where lumber is fairly cheap special drying sheds or racks are sometimes used. (See pages 31-33). The area of the drying

\* In Canada other methods have been used to procure raw material for briquette manufacture. See Bulletin No. 5—"Peat fuel and its manufacture," of the Bureau of Mines, Ont. (Department of Lands and Mines, Toronto.)

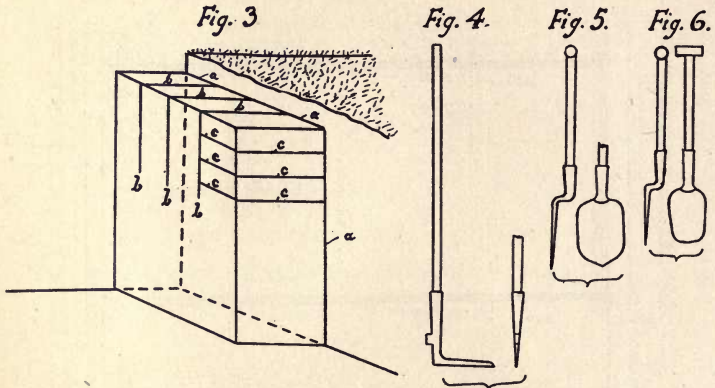
field should, if possible, be so large that it needs to be used only once during the season, in order to give the peat sufficient time to dry. The width required is then about five feet for each cross-section of the working trench, one foot in depth and breadth.

The work of digging the peat should commence as soon as the frost has sufficiently left the ground, in order to take advantage of the spring and early summer, during which time weather conditions are, as a rule, more favourable for the drying process than later in the season.

The tools used are a little different in different localities, but are generally of simple construction.

The following descriptions of the methods and tools used are chiefly obtained from the report of Messrs. Larson and Wallgren to the Swedish Government.

*Sparkaer, Denmark.*—The method used at Sparkaer is the one generally employed. The peat is cut out of the bog in brick-shaped pieces, as shown in Fig. 3. The vertical cut (a) is made with the knife-shaped spade, Fig. 4;



Method of Cutting Peat and Tools used at Sparkaer, Denmark.

the vertical cut (b) with a larger spade, Fig. 5; and the horizontal cuts (c) with a smaller spade, Fig. 6. Three peat bricks are cut and lifted up together and placed on the edge of the trench, or on the bottom if the worked out part of the bog is used for drying field. The bricks are laid out on the drying field and left until they are partly dried, when they are turned on edge, as shown in Fig. 7. They are later piled in cone-shaped heaps, see Figs. 8 and 9, and left until sufficiently dry or with 15–30 % moisture. The dimensions of the bricks in wet condition were about 10 x 6 x 3 inches. The labour cost per 1,000 pieces for digging, transportation to drying field and laying out for drying is 27 cents, and for turning and piling about 5 cents. The latter work is done by women and children. One air-dried peat brick weighed on



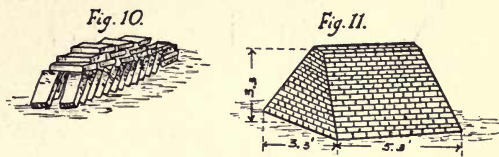
an average 0.8 lbs., making the cost of production of such peat 80 cents per ton of 2,000 lbs. Better humified and heavier peat is relatively cheaper,



Peat Bricks turned, raised and piled in heaps for drying, Sparkaer, Denmark.

as the men are generally paid for the number of the peat bricks produced, irrespective of their weight.

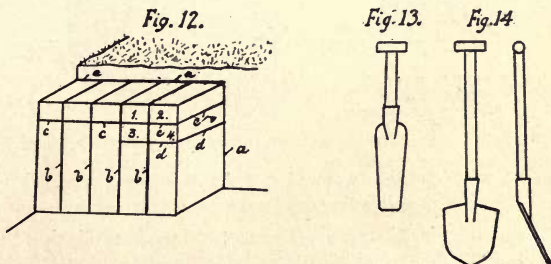
*Moselund, Denmark.*—The methods and tools used at this place were similar to those used at Sparkaer. The dimensions of the peat bricks in wet conditions were 9.2 x 6.4 x 3.2 inches and the average weight when air-dried about 1 lb. The men were paid 20 cents per 1,000 pieces laid out for drying



Peat Bricks raised and stacked at Moselund, Denmark.

and for turning and piling in heaps 6.5 cents, making the cost of production per ton 53 cents. When partly dried, the bricks were raised as shown in Fig. 10 and afterwards stacked as shown in Fig. 11.

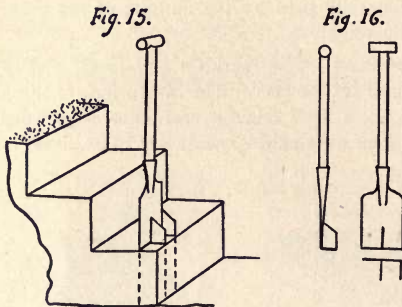
*Triangel, Braunschweig, Germany.*—The method used for digging the peat is shown in Fig. 12. The vertical cuts (a) and (b) are made with the



Method of Cutting Peat and Tools used at Triangel, Germany.

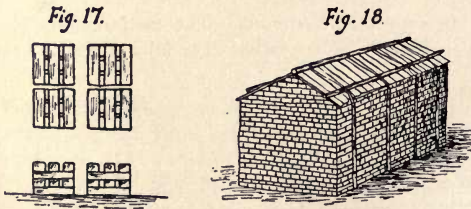
spade-shaped knife, Fig. 13, and the horizontal cuts (c) and (d) with the spade, Fig. 14. Four bricks, 1-4, were lifted together, placed on the edge of the trench and transported as usual to the drying field. The dimensions in wet condition were 12.4 x 6.4 x 4 inches. The price paid per 1,000 peat bricks for digging and laying out for drying was 25 cents and for the drying work 12 cents, making the cost of production about 50 cents per ton. with these prices a good workman made about \$1.10 per day.

*Haspelmoor, Bavaria, Germany.*—The method employed for digging the peat is shown in Fig. 15. Two peat bricks are cut out and lifted together with the same spade, Fig. 16. The consistency of the peat was such that



Method of Cutting Peat and Tools used at Haspelmoor, Germany.

the bricks could at once be piled, as shown in Fig. 17; later these piles were repiled with the upper bricks now placed underneath. When sufficiently dry the bricks were stored in sheds or stacked as shown in Fig. 18. The

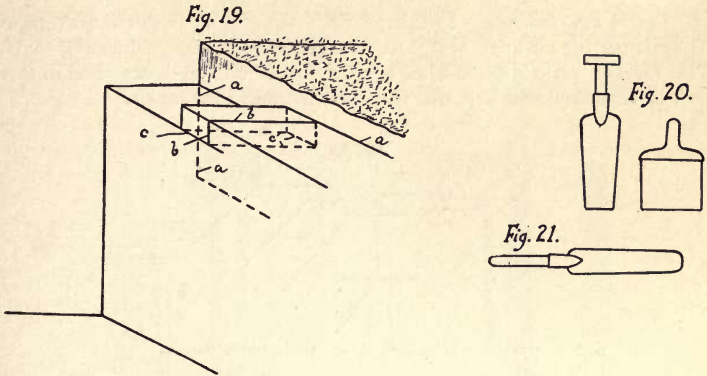


Peat piled in heaps for drying and stacked at Haspelmoor, Germany.

dimensions in wet condition were 14 x 4 x 3.2 inches. The price paid per 1,000 bricks for digging and laying out for drying was 20 cents.

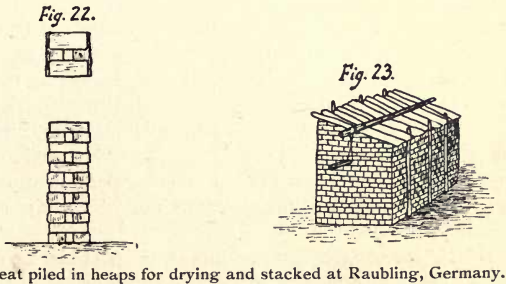
*Raubling, Bavaria, Germany.*—The method used for digging the peat is shown in Fig. 19. The vertical cut (a) is first made with the knife-shaped spade, Fig. 20, and afterwards the vertical cut (b) and horizontal cut (c)

with the long knife, Fig. 21, for one brick at a time. The dimensions in wet condition were 18 x 5.6 x 4.8 inches. The price paid per ton air-dried peat was 77 cents for digging and laying out and 44 cents for drying, making



Method of cutting Peat and Tools used at Raubling, Germany.

a total of \$1.21. The wet peat bricks were at once piled up as shown in Fig. 22, with 24 bricks in each pile, and afterwards repiled around a pole stuck in the ground, with 48 bricks in each pile. After some ten weeks they were stacked as shown in Figs. 18 and 23. The market price at Raubling station, about 3 miles from the bog, was \$2.32 per ton.

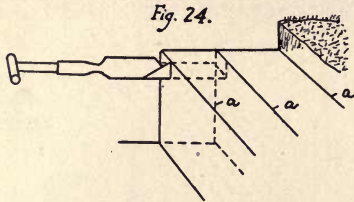


Peat piled in heaps for drying and stacked at Raubling, Germany.

*Bernau, Bavaria, Germany.*—The method used for digging the peat, as well as the tools employed, and the drying and stacking were done in a manner similar to that employed at Raubling. The production per man and day was 13.3 cubic yards of raw peat, which is equivalent to 4 cubic yards of air-dried peat containing 30% moisture. The price paid per cubic yard air-dried peat was 22 cents, making the cost of production per ton \$1.18, as the weight per cubic yard was about 370 lbs.

*Feilenbach,\* Bavaria, Germany.*—The cost of production at Feilenbach is \$1.40 per ton air-dried peat and with cost of drainage and general expenses included, \$1.75. The market price for lots of 10 tons loaded on cars at Aibling, a mile or two from the bog, is \$2.25 to \$2.40 per ton.

*Oldenburg, Germany.*—In this province the cost of production averages 65 cents per ton air-dried peat, and with general expenses included 87 cents. The market price is \$1.20-\$1.50 per ton loaded on the boats used in this part of Germany, which is well traversed by numerous canals.



Method of cutting Peat and Tool used in Russia.

*Russia.*—The tools used in Russia are similar to those shown in Figs. 4-6, 13, 14, 20, 21. In certain localities the method and tool shown in Fig. 24 is also used. The vertical cuts (a) are first made with a large spade and afterwards one brick at a time cut out and lifted with the tool shown. The cost of production in Russia is on an average 80 cents per ton air-dried peat.

#### CUT PEAT DUG BY MACHINERY.

Peat cutting machines are generally used in undrained bogs which are comparatively free from roots, trunks and stumps of trees, and in drained bogs when a larger production is aimed at. In this latter case the bogs must also be free from roots, trunks and stumps, which, if they occur in large numbers, seriously interfere with the working of these machines.

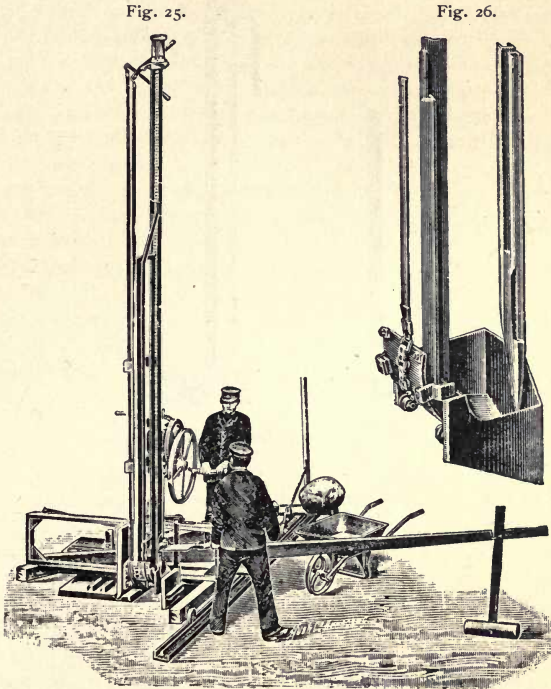
Cutting machines are also used in combination with the mixing and pulping machines used for the manufacture of machine peat, in which case they are preferably operated by a motor of some kind. A description of such a plant is given on page 72.

When used for the manufacture of cut peat, the peat block cut out by the machine is, by means of a hand-spade, divided into bricks of suitable size, which afterwards are air-dried, as previously described.

The cutting machines mostly used in Germany are made by the firm R. Dolberg in Rostock. Other manufacturers are: A. Heinen in Varel; Bartsch & Mitschke in Jasenitz; C. Weitzmann, in Greifenhagen; W. A. Brosowsky in Jasenitz, and Jaehne & Sohn in Landsberg. The machines are all of similar construction and the description of one of them is sufficient.

\* Hausding, Handbuch der Torfgewinnung.

The construction of *R. Dolberg's cutting machine* is shown in Figs. 25-26. The cutting tool is made of three vertical plates with sharp edges. This tool is pressed down by means of a rack and pinion into the bog to the desired depth, when a cylindrical plate, see Fig. 26, operated by a lever arrangement, cuts off the peatblock and holds it in place while it is lifted to the surface. The guide for the rack with pinion and turning wheel is securely mounted on



R. Dolberg's Cutting Machine.

a triangular stand, provided with wheels which can roll on boards laid out on the bogs, when it is desired to move the machine. The guide is movable on a frame, so that a fairly wide trench can be cut out.

Two men are required to attend each machine, one man operates the cutting tool, and the other cuts the peat block brought up into suitable pieces and loads these on wheelbarrows or trucks, which are generally transported by a third man to the drying field.

A small cutting machine made by the same firm, which is pressed down and lifted up by hand, is shown in Fig. 27 together with the spade used for

dividing the peat block into smaller pieces. This apparatus is suitably used in shallow, undrained bogs, when only a small production is desired.

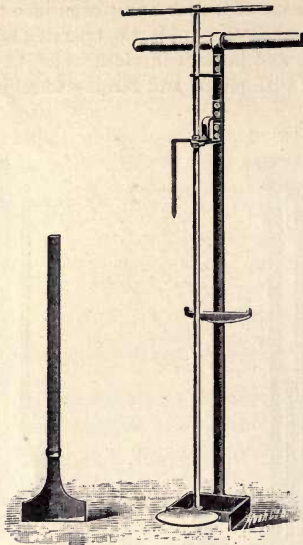


FIG. 27—R. Dolberg's small Cutting Machine.

The prices and weights of these machines\* and the depths to which they can work are given in the following table:—

	Approximate weight. lbs.	Price. marks.	Price. \$
Cutting machine for 2 meters = 6.6 feet deep	1408	565	135.60
“ “ 2.5 “ = 8.3 “	1419	578	138.75
“ “ 3 “ = 9.9 “	1430	590	141.60
“ “ 3.5 “ =11.5 “	1452	605	145.20
“ “ 4 “ =13.2 “	1463	620	148.80
“ “ 4.5 “ =14.8 “	1496	638	153.12
“ “ 5 “ =16.5 “	1518	655	157.20
“ “ 5.5 “ =18.1 “	1650	700	168.00
“ “ 6 “ =19.8 “	.....	.....	.....
“ “ 6.5 “ =21.4 “	.....	.....	.....
“ “ 7 “ =23.1 “	.....	.....	.....

Each machine is supplied with a key and a cutting spade.

The small machine shown in Fig. 27 weighs about 44 lbs. and costs 50 marks=\$12.00.

The peat briquetting plant† at *Ostrach* has 20 of Dolberg's cutting

\* At R. Dolberg's plant in Rostock, Germany.

† Report by Messrs. Larson & Wallgren.

machines at work during the season. The bog is undrained and has a depth of 10 to 13 feet. Each machine is attended to by three men and produced per day, on an average, 12,000 peat bricks of dimensions 9.2 x 4 x 4 inches. The horizontal cross-section of the peat blocks, cut out by the machine, is 12 x 9.2, inches and by moving the guide on the frame the bog is worked out in trenches 4 feet in width. The peat bricks are used at Ostrach as raw material for the manufacture of briquettes and are only partially air-dried. They still contain 55-60% moisture when brought to the briquetting plant. The price paid per 1,000 pieces weighing, with 55-60% moisture, approximately 2,200 lbs. was for cutting and laying out for drying 19-22 cents, depending on the distance to the drying field, and for drying (including stacking) 12 cents. Calculated on a basis of air-dried peat with 30% moisture, the cost per ton for cutting and laying out for drying is 32 cents and for drying 19 cents, total 51 cents per ton.

A cutting machine somewhat different from the Dolberg machine is constructed by Mr. N. Van Breemen of Haarlem, Holland. This machine is used only in undrained bogs and worked in connection with other machinery for mechanical treatment of the peat. A description of such a plant is given on pages 55-56.

#### SPECIAL DRYING ARRANGEMENTS.

Cut peat in rainy weather, on account of its porous nature, becomes saturated with water and when this occurs the drying must again start from the beginning. In order to be less dependent on weather conditions for the drying process, special drying sheds or racks are sometimes used, especially in localities where the necessary lumber is cheap. This naturally involves an extra expenditure of money, but in addition to independence of weather conditions other advantages are also gained. The peat dries more quickly and thoroughly, the drying season is lengthened, and the work of turning and piling the peat bricks, otherwise necessary, is avoided. The time required for drying in this manner varies considerably, but on an average it takes from 4 to 6 weeks. Each drying shed or rack is, therefore, used several times during the season.

In Figs. 28-31 different constructions of such drying sheds and racks are shown. The shed shown in Fig. 31, constructed by A. Anrep, is one of the most practical. The peat bricks, which are laid on pallets, are easily turned over on to the next pallet with their lower side uppermost, without impairing the shape of the bricks and the drying thereby hastened. During the season, 4 to 5 dryings can be made in such a shed.

The weight of one cubic yard cut peat, determined by the Swedish Peat Society, varies between 288-396 lbs., depending on the quality of the peat. As fuel for industrial purposes cut peat is less suitable on account of its bulkiness and porous nature. Theoretically a ton of cut peat should have the same heating effect as a ton of machine peat with the same content of moisture, but cut peat easily crumbles to pieces and a great amount of fines falls unburnt through the grates.

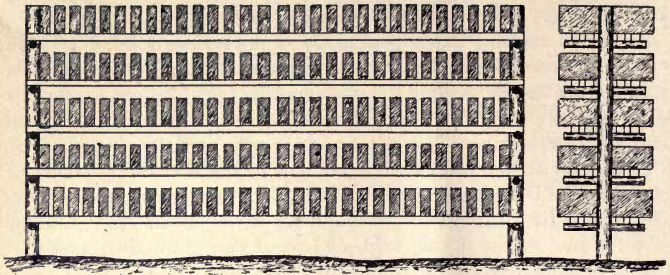


FIG. 28—Drying Rack.

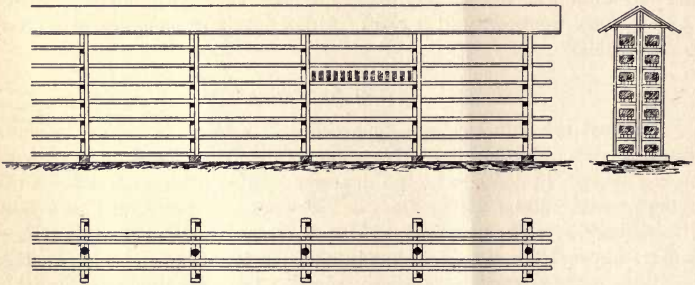


FIG. 29—Drying Shed.

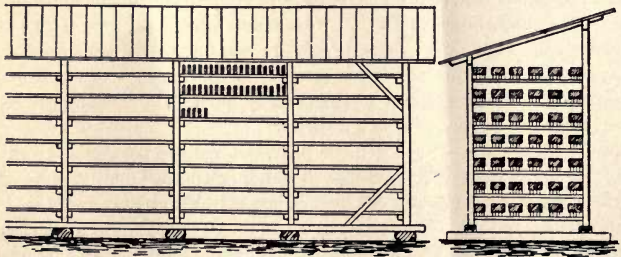


FIG. 30—Drying Shed.



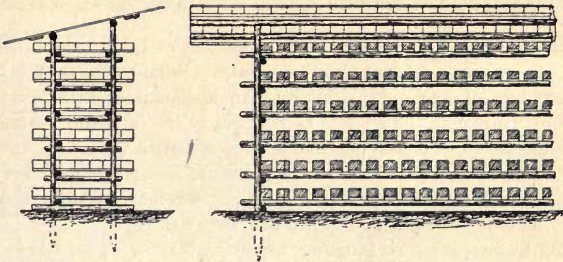


FIG 31—Anrep's Drying Shed.

## II. MACHINE PEAT.

The bulkiness of the cut peat, its comparatively small fuel value per unit of volume, its dependence on favourable weather conditions for drying and the ease with which it crumbles to pieces, are objectionable qualities which are overcome, at least to a great extent, by mechanical treatment. By the mechanical treatment the raw peat from the different layers of the bog is more or less thoroughly mixed and pulped, depending on the methods and machinery used. The more thorough these processes are carried out, the more solid is the fuel obtained and the better its quality. By pulping the peat, the cell walls are broken up and the moisture contained more easily evaporated. Thoroughly pulped peat is comparatively compact and the hollow spaces which it contains are very small. When such peat is exposed to the air the surface dries comparatively quickly and a kind of skin is formed. The pores in this skin close during rainy and damp weather, through the swelling up of the peat, preventing the moisture from entering the interior. In dry weather the pores open up again and the drying continues at practically the same content of moisture which the piece had before the rain, contrary to the cut peat, which easily becomes saturated with moisture.

The methods used for the manufacture of machine peat differ considerably and depend on the nature of the peat and on local conditions. The principal difference is, that in some methods, which otherwise may differ in details and machinery used, the peat is mixed with additional water and the product obtained afterwards moulded into the desired shape or otherwise treated.\*

In other methods, which also may differ in details and machinery used, the peat is treated without additional water† and leaves the machine in one or more continuous bands of rectangular cross-sections, and with such consistency that no special moulds are required. This peat is called machine-formed peat, pressed peat, or in many cases only machine peat.

\* This kind of peat is called in Germany "Schlammtorf," and in Sweden, Norway and Denmark "Älftorf."

† In some cases a small amount of water is added.

## 1. MACHINE PEAT MANUFACTURED WITH ADDITIONAL WATER.

(a) *Manufactured without the aid of machinery.* In some localities, when only a small quantity is desired or no capital available, the peat is treated without any special machinery either by manual labour or with horses.

In the former case the work is carried out in the following manner: One man digs the peat out of the bog and tramples it with the addition of water on the bottom of the trench to a thick porridge, which he later shovels into a bin, from which another man loads it into a wheelbarrow and transports it to the drying field, where it is dumped into moulds.

In the latter case a rectangular trough made out of boards is erected about  $3\frac{1}{2}$  feet below the surface of the bog. The peat in the neighbourhood is thrown down into this trough and water added. A horse ridden by a man or boy tramples and mixes the peat, which, when ready, is loaded into a cart and drawn by the horse to the drying field.

(b). *Manufactured with the aid of machinery.*—The machine mostly used consists of a vertical cylinder or a horizontal half cylinder, in which a shaft provided with knives placed in the form of a screw thread rotates. The raw peat, together with water, is fed in at one end. By means of the rotating knives the peat is more or less thoroughly mixed and pulped and moved towards the other end of the cylinder, where it leaves the machine as a homogeneous porridge. This peat porridge is at smaller plants shovelled direct into wheelbarrows or trucks and brought to the drying field. At larger plants it is first brought by means of elevators or conveying apparatus of some kind to a large bin, from which it is conveniently tapped as required into dumping cars and brought to the drying field.

The work of manufacturing machine peat is properly divided into four different processes, which are as follows:

1. Digging the raw peat out of the bog and transporting it to the plant.
2. The mechanical treatment of the peat.
3. Transportation to the drying field and laying out for drying.
4. Drying work.

The power required for the operation of the machinery used for treating the peat is furnished at smaller plants by animal power, and at larger plants by mechanical motors, usually a locomobile, but gasoline and electric motors are also used.

## ARRANGEMENTS AT SMALLER PLANTS.

The general arrangements at such plants are shown in Fig. 32 and Plate 1. The raw peat is dug from the trench (a) and thrown into a bin (b) placed at the side of the pulping machine (c). From the bin it is fed into the machine with additional water supplied by the pump (e). Sometimes the bin (b) is omitted and the peat dug out thrown directly into the machine. The pulped peat runs into a bin (d), from which it is loaded into

PLATE 1.



Small Peat Plant at Markaryd, Sweden.

PLATE 2.



Working Trench at Ökaer, Denmark.



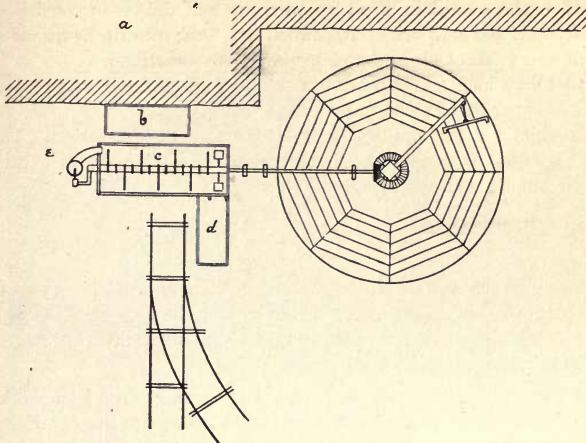


FIG. 32—General arrangements at a small Peat Plant.

wheelbarrows or cars and transported to the drying field. The surface of the bog is generally too soft to allow a horse to walk comfortably; boards are therefore laid down as shown in the figure. The shaft is brought to rotate by means of a simple bevel gear in the same manner as a threshing machine, and the pump (e) is brought into operation at the same time by a crank placed at the further end of the shaft.

These small plants are either placed on the bog and moved at the rate the bog is worked out, in order to reduce the transportation of the raw material to a minimum, or else placed convenient to the drying field, when the raw peat has to be transported to the plant. In this latter case the pulped peat mass is generally first conveyed to a bin, from which it can be conveniently tapped into dumping cars or carts.

The pulped peat is dumped on the drying field into large moulds, see Fig. 33, divided into rectangular sections of desired dimensions. By means

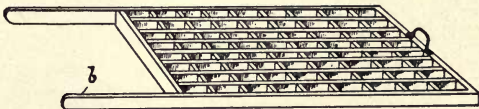


FIG. 33—Peat Mould.

of wooden scrapers the peat mass is levelled and made to fill up the mould, any excess being scraped into the next mould. After a few minutes, generally 10 to 12, the excess of water added has run away, and the peat bricks are sufficiently solid to allow the removal of the mould. The legs (b) at the back of the mould are of such length that the shape of the peat bricks is not im-

paired when the mould is lifted up in front and drawn forward. When sufficiently dry, the peat bricks are turned and later piled in heaps, as shown in Figs. 8 and 9, stacked or stored as previously described.

With 4 to 6 men and one horse a production corresponding to 5-8 tons air-dried peat per day can be obtained.

This method is the one best adapted for a small production. The machinery employed is simple and inexpensive, and the peat fuel produced fairly well pulped and mixed.

#### ARRANGEMENTS AT LARGER PLANTS.

The general arrangements, methods of working and machinery employed at such plants differ considerably in different localities, and in order to illustrate better these different arrangements, individual descriptions of some of the more important plants are given.

*Sparkaer, Denmark.*—The peat bogs at Sparkaer have been worked for many years, and at present nine different peat plants are in operation. The season during 1907 was exceedingly wet and unfavourable, but, nevertheless, 14,645\* tons of peat fuel were produced.

The different plants at Sparkaer are all of similar construction, but of different capacities. The methods used for digging, transportation and drying are also identical. The plants and methods used at Sparkaer are under the prevailing local conditions very practical, and their introduction is largely due to Mr. M. Rahbek.

*The Ökaer Plant.*—This is the largest plant and was built in 1884, since which time it has been in continuous operation. The plant was built on solid ground close to the margin of the original bog, which, however, since that time has been worked out to a considerable extent. Level, sandy plains, free from trees or other obstacles to the wind and in the immediate vicinity of the plant, are used for drying fields. The drying conditions are, therefore, exceedingly favourable, which largely accounts for the success of these plants. During 1907 the production from the Ökaer plant was 3,850 tons peat fuel. The capacity of the plant is about double this amount, but at present it is not worked to its full capacity.

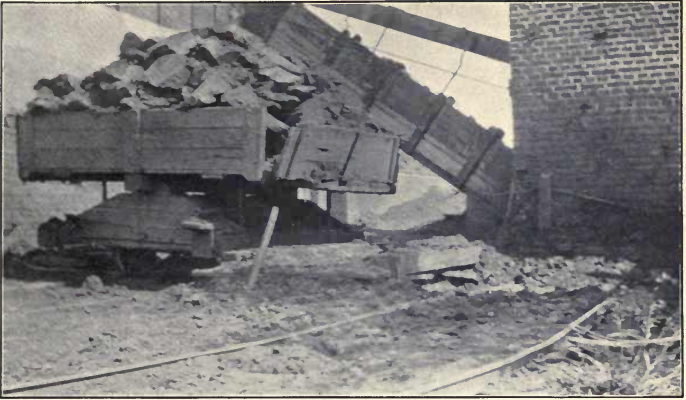
Figure 34 shows the general lay out of the plant.

1. Digging and transportation of the raw peat.—The bog is sufficiently drained, contains well humified peat and is free from roots, trunks and stumps of trees. The upper layer to a depth of some four inches is thrown into the previous working trench, which at the rate the bog is worked out is brought under cultivation. At present the bog is worked to a depth of 8-9 feet.

The bog is connected with the stationary plant by a railway, which is gradually increasing in length. Close to the part of the bog which, at the

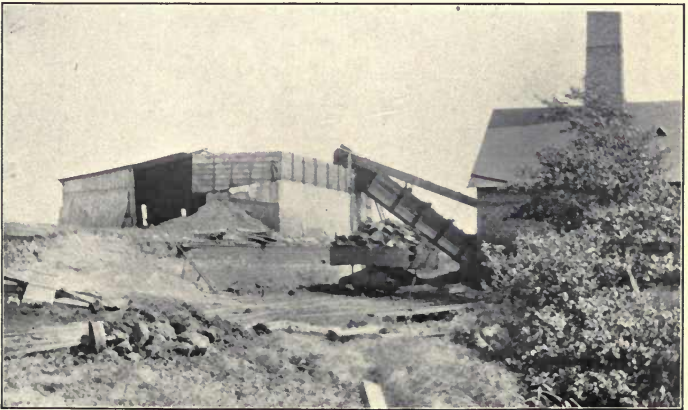
\* Mosebladet, Sept., 1907.

PLATE 3.



Car for Transport of Raw Peat, Ökaer, Denmark.

PLATE 4.



Peat Plant at Ökaer, Denmark.

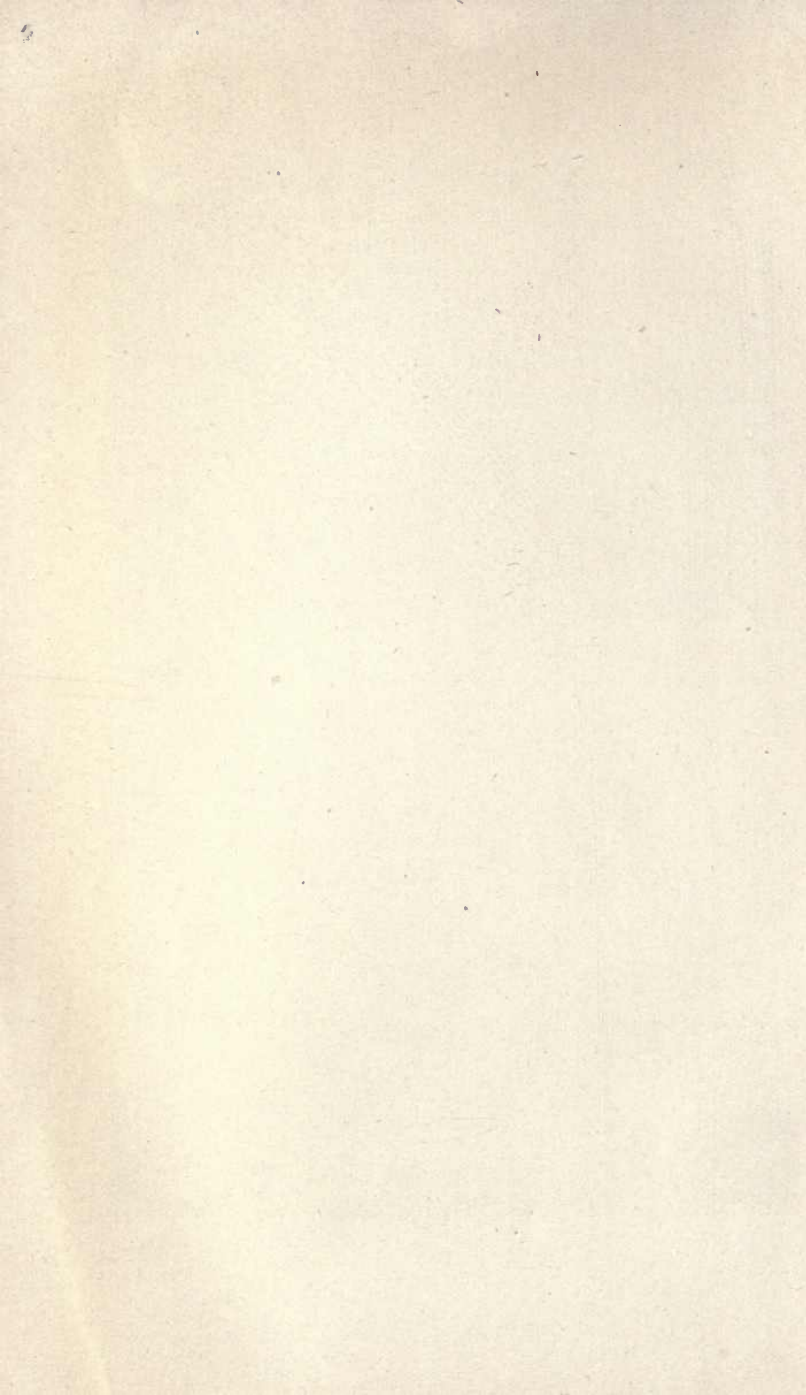
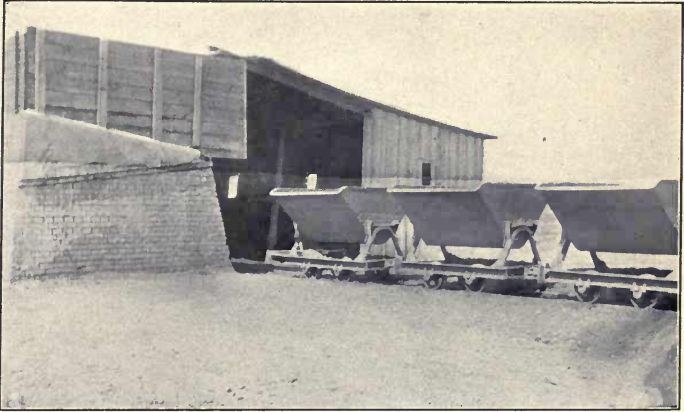




PLATE 5.



Dumping Cars for Pulped Peat, Ökaer, Denmark.

PLATE 6.



Peat Heaps at Ökaer, Denmark.



time is being worked, a side track (see also Plate 2) is laid down, so that the bog is attacked from two tracks about 25 feet apart. From each track a trench 25 feet wide is worked out. The rails are laid on old railway ties, which are placed close together on the bog and a little above the water level,

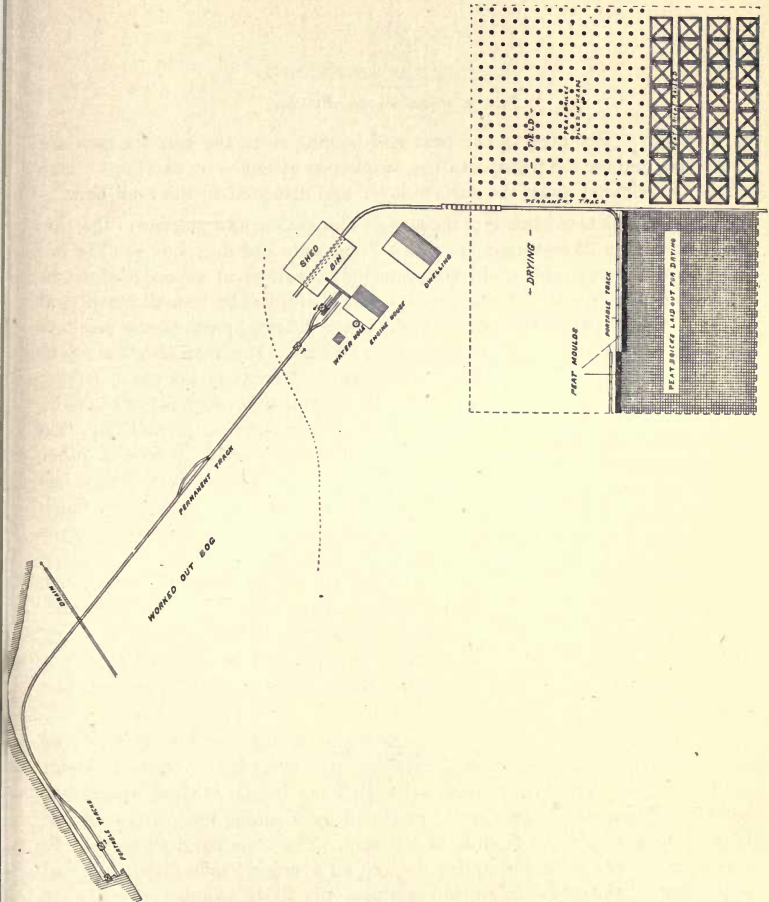


FIG. 34—Sketch plan of the Peat Plant at Ökaer, Denmark.

in order to enable the horses, which are used for the transportation of the raw peat to the plant, to walk comfortably. The peat is dug out with the spades shown in Fig. 35 and loaded on wooden cars (see Plate 3), which can be tilted either to right or left and hold about 4 cubic yards of raw peat. Each car is hauled by one horse between the bog and the plant and is attended



FIG. 35—Spades used at Ökaer

to by a boy. For digging the peat and loading it on the cars six men are employed, and for the transportation, two horses attended by two boys. One extra man cleared away the surface layer and attended to the road beds.

2. Mechanical treatment of the peat.—The mixing and pulping of the raw peat is done in a 25 feet long and about 2 feet wide and deep box, see Fig. 36, in which the shaft supplied with the usual knives rotates at a speed of about 50 revolutions per minute. The necessary water is supplied by a small centrifugal pump to a tank, from which it is brought to the different parts of the machine and regulated by the man attending to the feeding. This man also attends to the tilting of the cars loaded with the raw peat. A great part of the load falls, when the car is tilted, directly into the machine, but that which is left has to be raked or shovelled into it. Tracks are laid on both sides of the machine (see Plate 4) so that when one car is emptied a full car is brought up on the other side and the empty one hauled back to the bog. The pulped peat, which has the consistency of porridge, runs from the machine to an elevator which conveys it to the loading bin (see Plate 4), placed at such a height above the ground that it can conveniently be tapped into cars. The elevator consists of a wooden trough provided at each end with a shaft supplied with two sprocket wheels and chains. The chains are provided with pallets which run against the bottom of the trough and scrape the peat porridge along. The upper shaft is also provided with a pulley, which is operated by a belt from the engine. The power required is furnished by a 20-h.p. steam engine attended by one man.

3. Transportation to the drying field and laying out for drying.—The peat porridge is loaded into steel dumping cars (see Plate 5), holding about  $\frac{3}{4}$  cubic yards. The bin is provided with holes in the bottom at suitable distances apart, which are opened or closed by a simple lever arrangement, permitting a very rapid loading of the cars. The time required to load 12 cars, transport them to the drying field on an average  $\frac{1}{4}$  mile distant, unload and transport them back to the bin occupies only 10–12 minutes.

A permanent track is laid from the bin through the centre of the drying field, dividing it into two parts. The peat is first laid out on one side of this track by means of a portable track some 800 feet in length, and when the whole area is covered this track is moved over on the other side and the work continued. As a rule, the peat has ample time to dry before the same

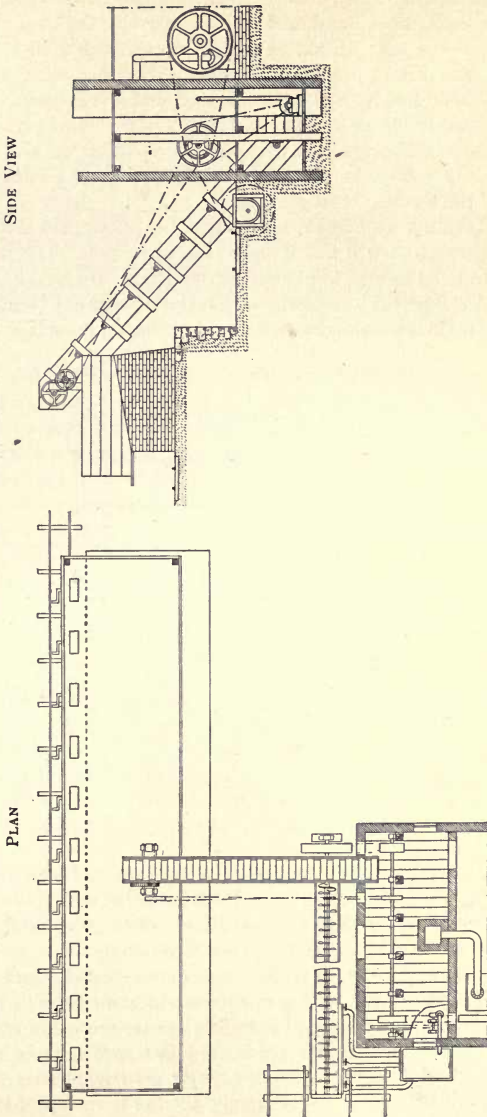


FIG. 36.—Peat Plant at Ökaer, Denmark.

field is needed again. The portable track is made in sections, which are easily disconnected, moved and again put in place by the men attending to the moulding of the peat bricks. For this process, one man is needed for every 25,000 peat bricks produced per day. The production last summer was between 80,000 and 100,000 bricks per day, and four men were, therefore, employed on the drying field. The sections of the portable track are connected by means of sliding shoes which are moved over on the rails of one section when it is to be removed, and slid over to cover the joints when it is desired to put the sections together.

The moulds used, see Fig. 37, are made of boards and are divided into 55 rectangular spaces  $10 \times 5.6 \times 3.2$  inches in dimensions. The front is supplied with two handles and the back with two legs, 20 inches long, made of round iron. In order that the shape of the bricks may not be impaired, the mould is lifted up in front and drawn forward resting on these legs.

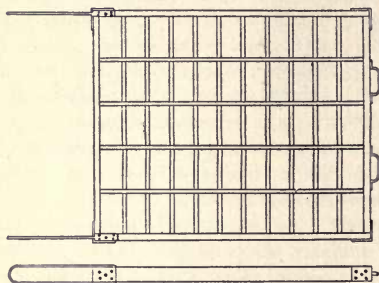


FIG. 37—Peat Moulds used at Ökaer.

The peat porridge is loaded at the bin on a train of 12 cars, which is hauled to the drying field by two horses attended by a man and a boy, who also attend to the loading. Each car contains enough material to fill three moulds. Since the length of two cars is equal to that of three moulds, the train, when first brought up to the moulds, discharges only every other car; it is then moved forward a distance equal to its own length, and then discharges the remaining full cars.

The peat mass is levelled by means of wooden scrapers and made to completely fill the moulds. As soon as the moulds in front of one section of the track are filled, this section is moved back a distance equal to the depth of these and when the peat is sufficiently dry to retain its shape, which usually takes 10–12 minutes, the moulds are also moved the same distance. No time is, therefore, lost in waiting, as the men have sufficient time to remove the sections of the track and the moulds while the cars are being reloaded and again brought back to the drying field. The last section to be removed is the curve connecting the portable track with the permanent one. This curve is connected as shown in Fig. 38 by simply putting it on top of the straight rails and is done in a very short time.

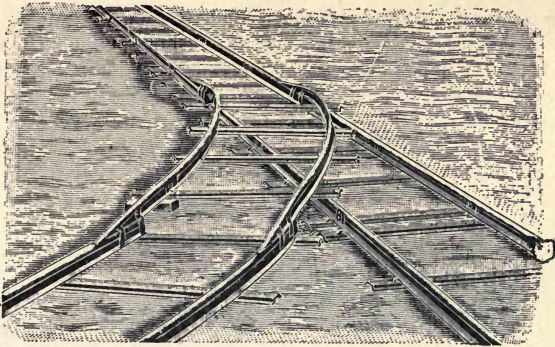


FIG. 38—Portable Curve.

4. Drying.—When the peat bricks are sufficiently dry to be handled, they are raised on edge, resting against each other, and turned so that the sides which previously were underneath are now most exposed to the air. They are left in this position until sufficiently dry to be piled in heaps. These heaps (see Plate 6) are made conical, 5–6 feet in height.

The drying work is generally done by women and children by contract. A skilled woman can raise and turn 6,000 bricks per hour or pile up 2,500 in such heaps.

Under favourable weather conditions the drying down to some 25% moisture is accomplished in about three weeks, but usually a longer time is required.

The peat bricks when dried are generally loaded on large waggons, brought to the nearest railway station, about  $1\frac{1}{2}$  miles from the bog, and loaded on railway cars. If they have to be stored at the plant, they are piled in large stacks as shown in Plate 7, but the cost of stacking has then to be added to the cost of production and stacking is, therefore, avoided if possible. At Sparkaer the working season generally lasts about 115 days and starts as soon as the frost has sufficiently left the ground.

#### Approximate Cost of Production.

During the season 1907, which as previously stated was exceedingly wet and short, the daily production (10½ hours) averaged 86,000 peat bricks. Each brick weighs 1.1 lbs. when air-dried. The daily production was, therefore, 47.3 tons.

The number of men employed was:—

6 men, digging the peat out of the bog.

2 boys and 2 horses for transportation of the raw peat to the plant.

1 man, clearing the surface of the bog.

1 man, attending to the pulping machine.

1 engineer.

1 man, 1 boy and 2 horses for transportation of the pulped peat to the drying field.

4 men on the drying field.

Total:—14 men, 3 boys and 4 horses.

The men were mostly paid by contract, but on an average they were said to make \$1.35 to \$1.65 per day, or say \$1.50\*, and the boys 75 cents. Assuming that the cost of a horse is 60 cents per day, the total cost would be:—

	Per Day	Per Ton
For digging, pulping, transportation and laying out:—	\$	Cents
14 men at \$1.50 per day.....	21.00	44.4
3 boys at \$0.75 per day.....	2.25	4.7
4 horses at \$0.60 per day.....	2.40	5.0
For Drying work:—		
5 cents per 1,000 pieces.....		9.0
For loading and carting to railway, approx.....		25.0
For fuel, oil, repairs, etc., say.....		11.9
Total.....		100.0

To this must be added interest, amortization and general expenses, probably amounting to some 50 cents per ton, making the total cost about \$1.50 per ton.

The price obtained, f.o.b. Sparkaer station, was \$1.95 per ton. The fuel had a well established market and was easily disposed of.

In Denmark the method described above is the one mostly used and in localities where drying conditions are favourable and the peat well humified this method is one of the best.

*Stafsjö, Sweden.*—The method used at Sparkaer was introduced at the above place in 1899. Two plants were built, each having a capacity of 30–40 tons per day. The available drying fields were not large enough, however, and the production was decreased to some 25 tons per day for each plant. The surface of the bog was used for drying field. Each plant was run with a 8 h.p. gasoline engine.

The cost of production during the summer 1901 was in detail as follows:—

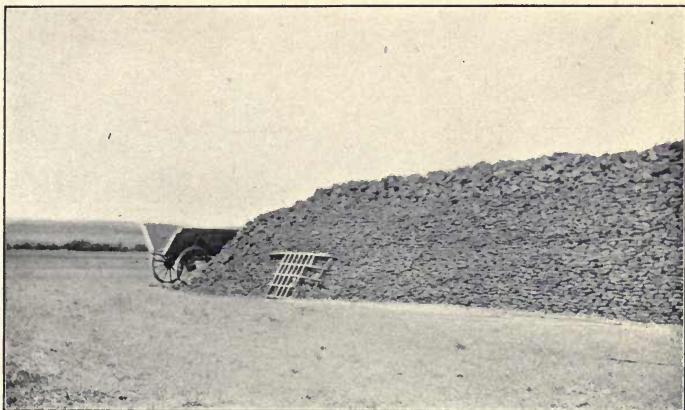
	Per Ton.
4 men digging the raw peat out of the bog. .	15.72 cents
1 man attending the pulping machine. . . . .	3.92 “
1 engineer. . . . .	4.91 “
1 foreman on the drying field. . . . .	4.41 “
2 helpers “ “ . . . . .	7.85 “
3 drivers. . . . .	8.11 “
1 boy cleaning moulds. . . . .	1.27 “
3 horses. . . . .	8.83 “
Gasoline and oil. . . . .	5.90 “
Turning the peat bricks. . . . .	4.91 “
Heaping “ . . . . .	4.91 “
Stacking “ . . . . .	12.73 “
	<hr/> 83.47 “
Miscellaneous work, track laying, etc. . . . .	12.27 “
Interest, amortization, etc. . . . .	24.57 “
Administration. . . . .	12.27 “
Loading on railway cars . . . . .	12.27 “
Total. . . . .	<hr/> 144.85 “

or in round figures \$1.50 per ton.

\* This figure is probably too high.

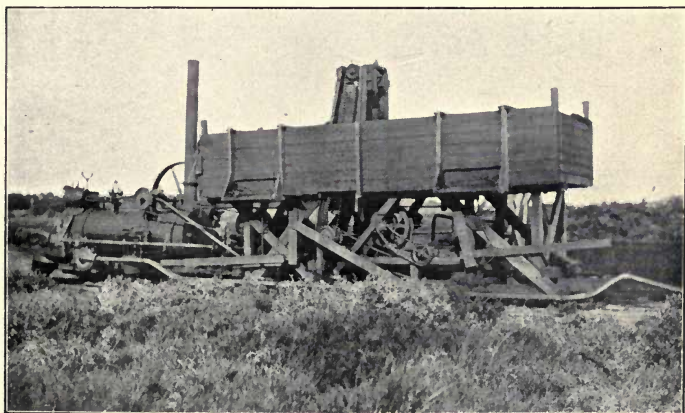


PLATE 7.



Peat Stack at Sparkaer, Denmark.

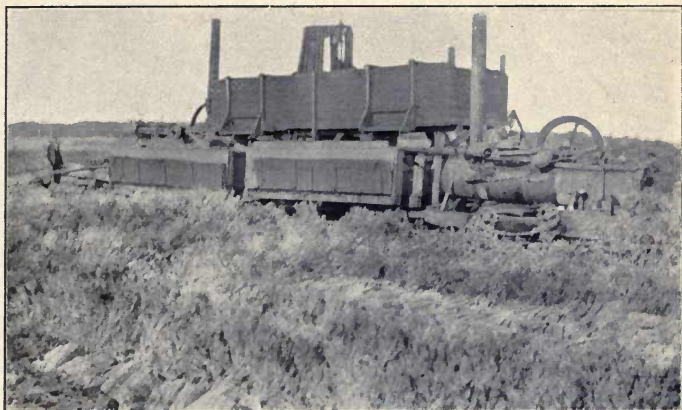
PLATE 8.



Peat Plant at Herning, Denmark.

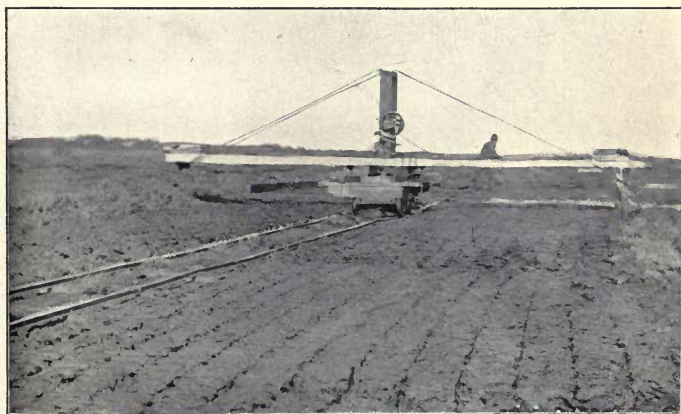


PLATE 9.



Peat Cars and Locomotive at Herning, Denmark.

PLATE 10.



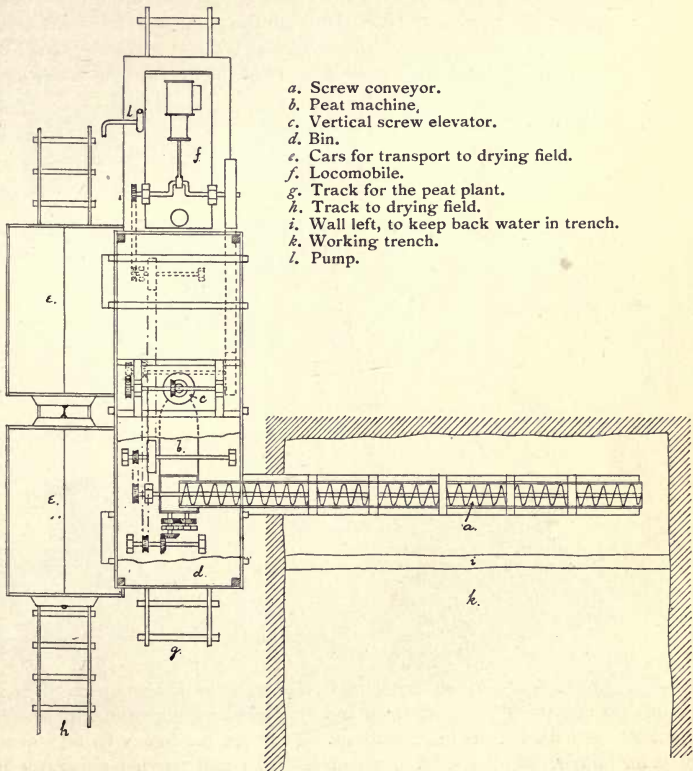
Mould Lifting and Moving Device at Herning, Denmark.



The price obtained was \$2.00 per ton, leaving a profit of 50 cents per ton. The weight of one cubic yard was 594–610 lbs.

*Herning, Denmark.*—The methods and machinery used at Herning differ considerably from those used at Sparkaer. At Herning the surface of the bog is used as a drying field. The bog contains well humified peat of good quality and is worked to a depth of 7 to 8 feet. The machinery used for the treatment of the peat is mounted on a movable platform, and is moved on the edge of the working trench at the rate the work proceeds. The transportation of the raw material to the plant is, therefore, avoided.

The raw peat is dug out from a trench (k) about 30 feet in width, thrown into the long screw conveyor (a), see Fig. 39, where water is added and conveyed to a Dolberg peat machine (b). This machine consists of two horizontal screws, which rotate against each other, mixing and kneading the pulp



- a. Screw conveyor.
- b. Peat machine,
- c. Vertical screw elevator.
- d. Bin.
- e. Cars for transport to drying field.
- f. Locomobile.
- g. Track for the peat plant.
- h. Track to drying field.
- i. Wall left, to keep back water in trench.
- k. Working trench.
- l. Pump.

FIG. 39—Sketch Plan of the Peat Plant at Herning, Denmark.

mass. A full description of the Dolberg machine is given on pages 64-65. From this machine the peat mass is conveyed by a vertical screw elevator (c) to a large bin (d), see Plate 8, placed above the platform. The power required is furnished by a 16 h.p. locomobile (f), mounted on the same platform as the peat machine, bin and elevator. The platform is provided with wheels and moves on rails (g) laid down at the edge of the trench. These rails are taken up and laid down in front of the plant at the rate the trench is worked and when the plant needs to be moved. On the side of the plant a portable track (h) is laid down for the transportation of the peat mass to the drying field. This track is made in sections which are easily moved when the end of the working line is reached and the plant has to be moved back and another trench started.

The peat porridge is tapped from the bin (d), which has two spouts, into two large wooden cars (e), see Plate 9, which also shows the locomotive used for hauling the cars back and forth between the plant and the drying field.

On one side of the drying field a permanent track is laid down, see Fig. 40, and by means of a portable track any part of the drying field is reached.

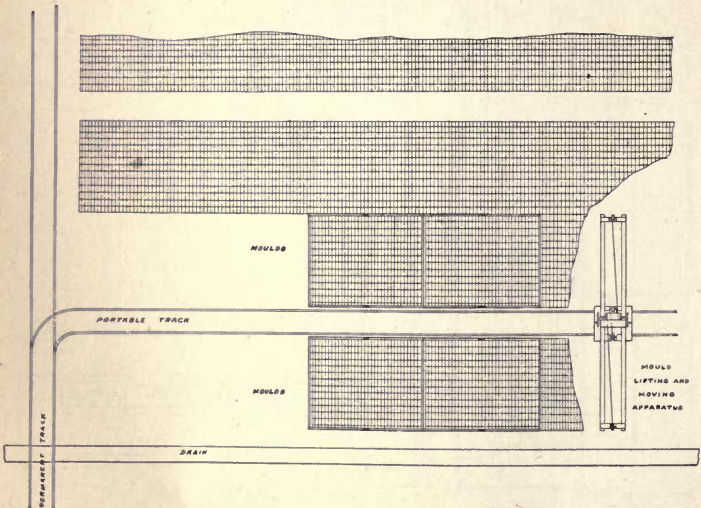
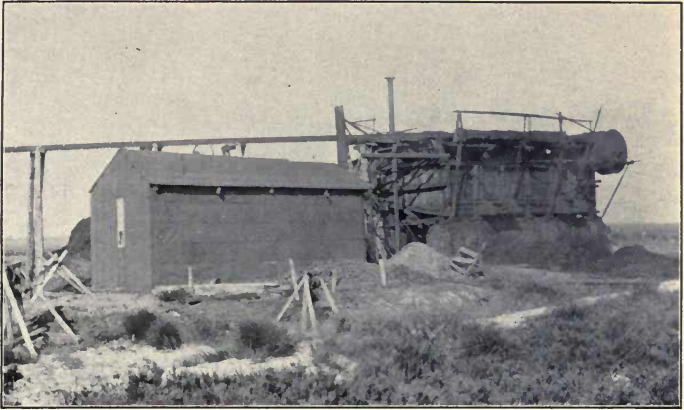


FIG. 40—Drying Field at Herning, Denmark.

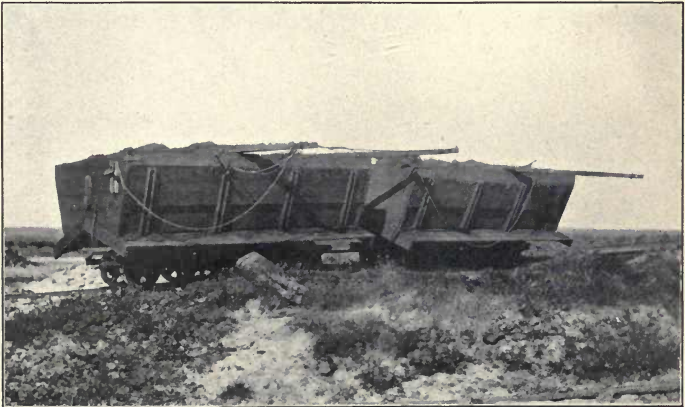
On each side of this portable track two large iron moulds are used. These moulds are made of  $\frac{1}{8}$  inch sheet iron and divided into 500 rectangular spaces about 7.2 x 3.6 x 2 inches in dimensions. They are too heavy to be moved by hand labour, and a special mechanical lifting and moving apparatus is therefore used for this purpose.

PLATE 11.



Peat Plant at Moselund, Denmark.

PLATE 12.



Peat Cars at Moselund, Denmark.





This apparatus, see Plate 10, consists of a double winch mounted on a movable truck, which is provided with two long beams on each side, with chains and necessary blocks. The two forward moulds are first lifted and moved a distance equal to double the length of one mould. This distance is measured by a chain of the required length, one end of which is fastened to each of the two moulds on the same side of the track. Later the two remaining moulds are lifted, moved and placed beside the two first ones. By this arrangement two men are sufficient on the drying field for a daily production of 100,000 peat bricks of the above dimensions. These moulds are stronger and need less repair than the wooden ones. The useful area of the drying field is decreased by the areas occupied by the portable track, which must be taken into consideration, especially where only a small area can be had for drying purposes.

The drying of the peat is done in the same manner as previously described.

#### Approximate Cost of Production.

The daily production (10 hours) averaged 70,000 peat bricks. Each brick, air-dried, weighed 0.88 lbs., making a daily production of 30.8 tons.

The number of workmen employed was 10, divided as follows:—

- 5 men digging the peat and attending to the machine.
- 1 engineer at the plant.
- 1 extra man at the plant.
- 1 man attending to the locomotive used for transportation.
- 2 men on the drying field.

These men were each paid 0.05 kronor=1.35 cents per 1,000 bricks laid out for drying. The contract price for turning and piling the bricks was 5 cents per 1,000.

The labour cost per ton of peat at the bog was, therefore, 42 cents. Adding to this, interest, amortization and the various other items, the total cost f.o.b. Herning's station is probably around \$1.25 per ton.

*Moselund, Denmark.*—The general arrangements at this plant, see Fig. 41, are in some respects similar to those at Herning. The peat plant itself, however, is stationary and the raw peat has to be transported to the plant. The bog, which contains peat of good quality, is worked from a number of tracks about 25 feet apart. The loaded cars are brought, by means of a hoist, up the elevated track to the peat machine, which is placed at such a height above the ground that the cars used for transportation of the peat porridge to the drying field can conveniently be loaded from the bin placed underneath this machine (see Plate 11). The raw peat is dumped into two screw conveyors, which convey it to a Dolberg machine, where it is mixed with additional water and kneaded. From there it goes into the bin placed underneath.

The cars used for the transportation of the peat porridge are shown in Plate 12.

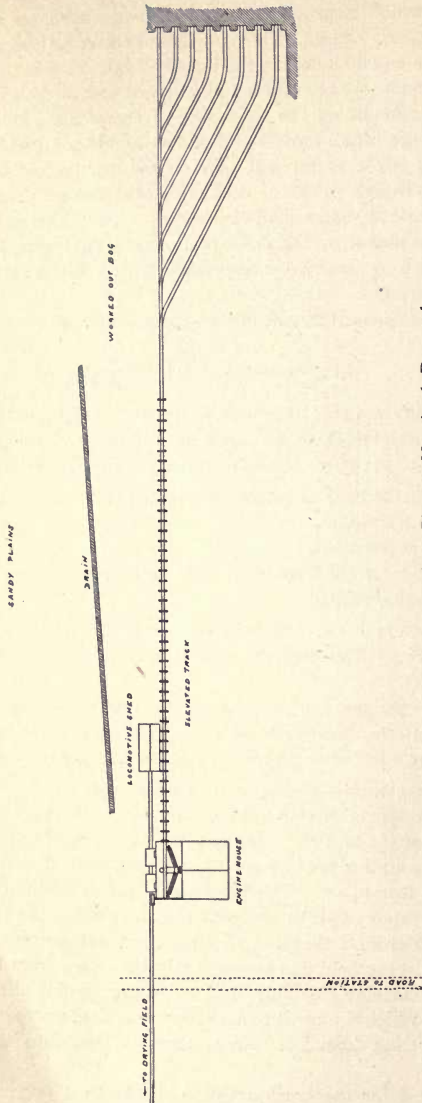
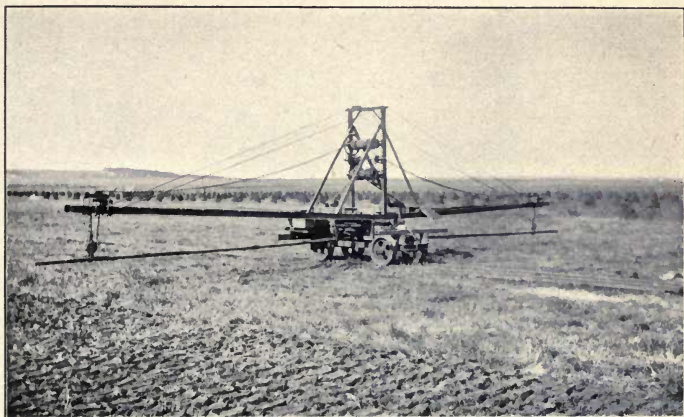


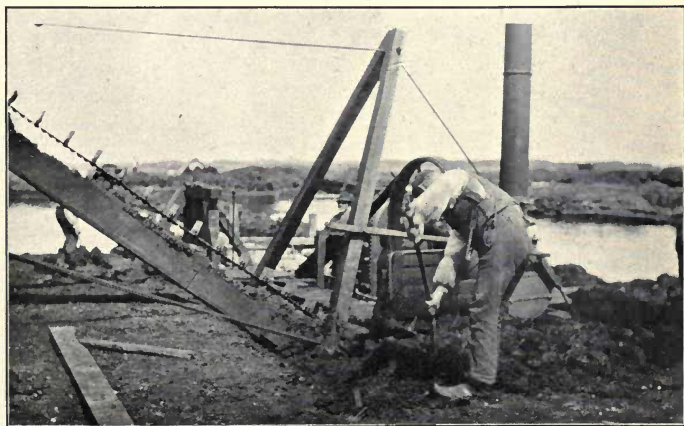
FIG. 41—Sketch Plan of the Peat Plant at Moselund, Denmark.

PLATE 13.



Mould Lifting and Moving Device at Moselund, Denmark.

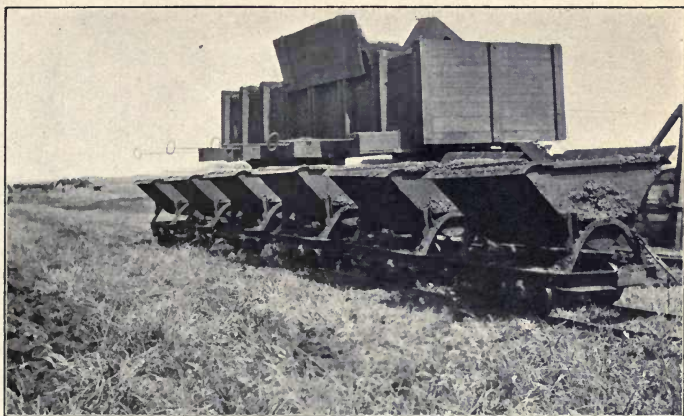
PLATE 14.



Floating Peat Plant at Aamosen, Denmark.



PLATE 15.



Bin and Peat Cars at Aamosen, Denmark.

PLATE 16.



Car for transport of Dried Peat, Aamosen, Denmark.



A small locomotive is used for hauling the two cars back and forth. The cars are conveniently emptied by means of a lever arrangement, which raises the lower portion of the sides and thus permits the peat porridge to run out into the moulds. These moulds, of which four are used, are of the same construction as those described at Herning. The apparatus used for lifting and moving the moulds is also similar to that used at Herning, but of neater construction and made entirely of iron, see Plate 13. The drying work is done in the usual manner.

The capacity of this plant is about 50 tons air-dried peat per day of 11 hours, with 16 men. The necessary power is furnished by a 15 h.p. steam engine, which is sufficient also for the operation of a smaller plant located close by. This plant consists of a Dolberg machine placed below the surface of the ground so that the loaded cars can be easily dumped. The kneaded peat mass is conveyed, by means of a vertical screw conveyor, to a bin placed above, tapped into cars and transported to the drying field.

The air-dried peat is conveyed to the station at Moselund, about  $1\frac{1}{2}$  miles distant, and loaded on railway cars. The price obtained f.o.b. Moselund was \$2.10 per ton.

In 1904 the cost of production, inclusive of interest and amortization, amounted to 84 cents per ton.\*

The plants described above, with the exception of the Stafsjö plant, are all located in Jutland, Denmark, and in this locality the price of bituminous coal was on an average \$4.00 per ton.

*Aamosen, Denmark.*—The bog worked at this place is not drained and the method of working is, therefore, different from those previously described.

The mixing and pulping machinery, together with elevator and locomobile are placed on a barge floating in the working trench (see Plate 14) and are moved forward at the rate the work proceeds. The elevator conveys the peat mass to a bin movable on rails laid down on the edge of the trench. From this bin the peat porridge is tapped into dumping cars (see Plate 15) and transported to the drying field, which here is the surface of the bog. The moulds and drying process used are the same as those employed at Sparkaer.

The construction of the barge used and the arrangement of the machinery which it carries are shown in Fig. 42. When the first trench is started, the surface layer is removed and a hole dug of the dimensions of the barge to a depth of about three feet below water level, which is sufficient to keep it floating. The barge is placed in the hole and when the machinery is started the peat first dug out is thrown into the pulping machines A and B, where water is added. These machines are of the same construction as that described at Sparkaer.

The peat porridge leaving these machines is, in the plant shown in Fig. 42, also put through an additional machine C, which delivers it to an elevator. The power required for this plant, which under normal conditions has a capacity of 17 to 22 tons air-dried peat per day of 11 hours, is 4 h.p. furnished by the locomobile. The elevator D conveys the peat porridge to the bin E,

\* From G. von Feilitzen, Svenska Mosskulturforeningens Tidskrift, 1905.

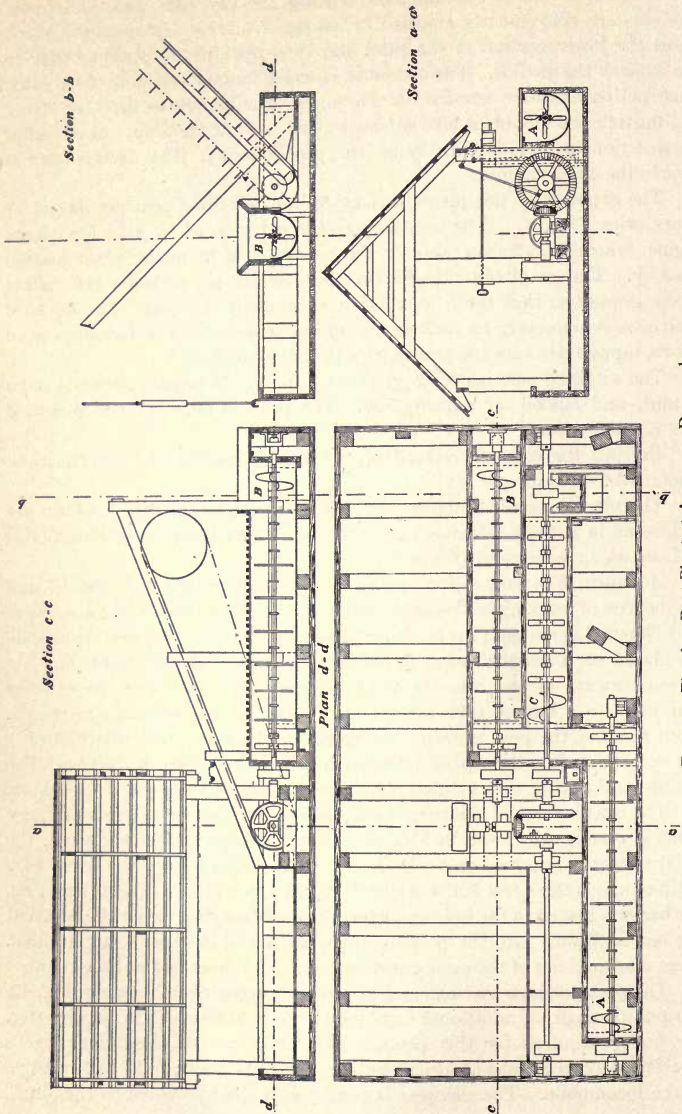


FIG. 42—Floating Peat Plant at Aamosen, Denmark.



see Fig. 43, from which it is tapped into the dumping cars F. A train of six cars is hauled by one horse to and from the drying field.

The peat in front and on the side of the barge is dug out, as shown in Fig. 43, until some four inches above water level, when walls (a) are left to keep out the water while the lower layers are dug out to the desired depth, in this case about three feet below the water level.

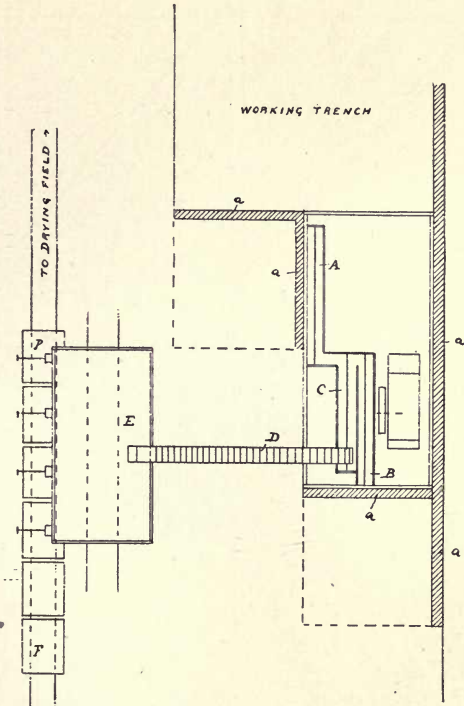


FIG. 43—Sketch Plan of the Peat Plant at Aamosen, Denmark.

When the peat, in front of the barge, has been removed from such an area that the barge can be moved half its length, the walls (a) are dug out to sufficient depth and the barge and bin moved forward this distance. Simultaneously as the peat in front of the barge is removed, the peat on the side is also removed.

The greater distance the barge can be moved in a straight line the better it is, as less time then is consumed in moving tracks and plant. When the end of the working line is reached, the barge has to be drawn back to the beginning and another trench started.

Fig. 44 shows a plant of the same construction, but where the additional mixing machine C, in Fig. 42, has been omitted. This simplifies the construction to some extent without impairing the quality of the fuel from this bog.

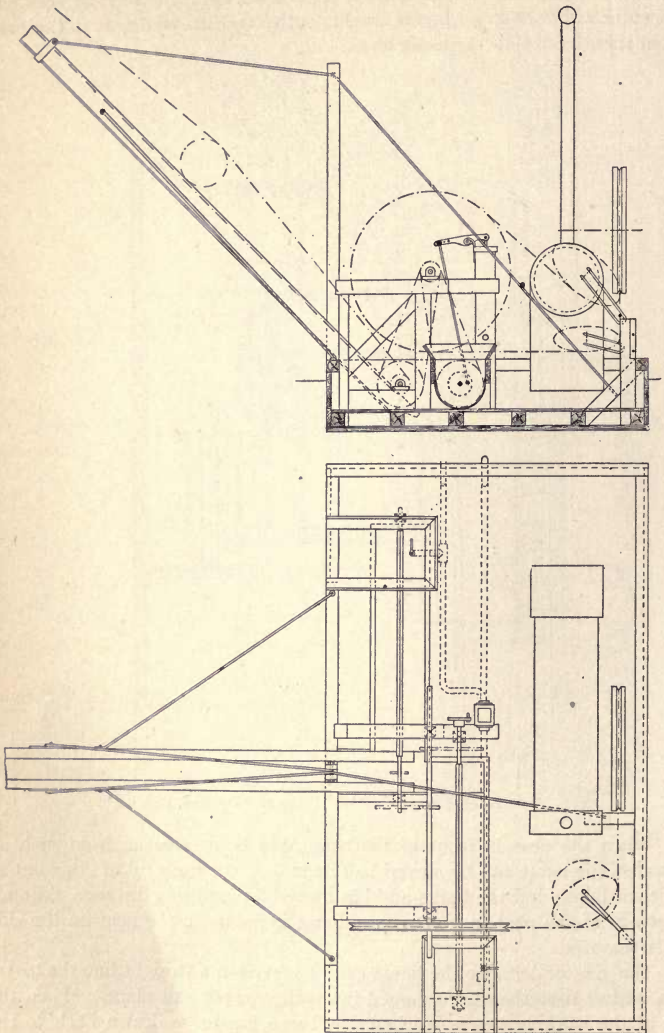
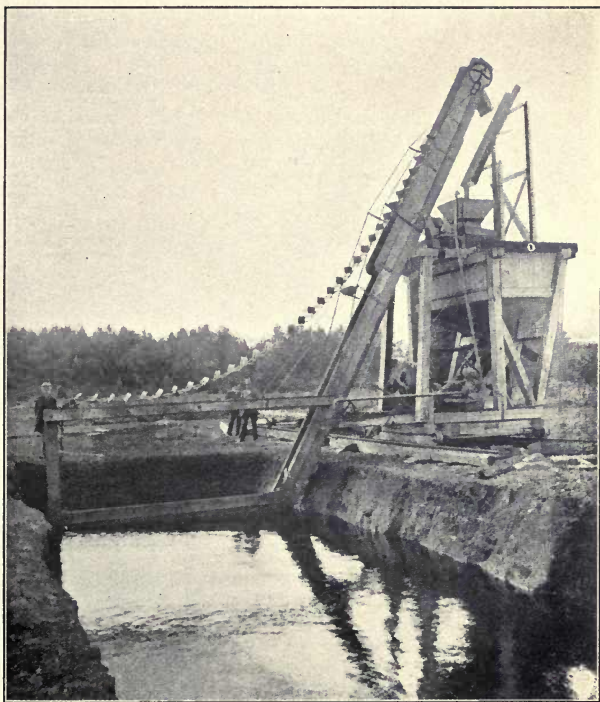


FIG. 44—Floating Peat Plant at Aamosen, Denmark.

PLATE 17.



Th. Ekholms Peat Plant at West Torup, Sweden.



The number of men employed at each of these plants is as follows:—

3 men for digging the peat.

1 engineer.

1 man and 1 horse for transport of the peat mass to the drying field.

3 men on the drying field.

1 man for digging and removing the surface layer.

---

Total: 9 men and 1 horse.

The men were paid 20 cents per 1,000 peat bricks laid out for drying, and for the drying work the people employed were paid 5 cents per 1,000. The weight of each air-dried brick averaged 0.82 lb.

The labour cost per ton (not including the horse) was, therefore, 61 cents. In 1906, which year was more favourable for the manufacture of peat fuel, the total cost per ton at the bog (not including interest and amortization, was 89 cents.

The air-dried peat was loaded on cars shown on Plate 16, which were hauled by horses to the station at Vedde, a distance of about  $5\frac{1}{2}$  miles. The cost of loading, hauling and unloading on railway cars was about 25 cents per ton.

The price obtained f.o.b. Vedde Station was \$2.42 per ton. The price of coal was about \$4.50 per ton in this part of Denmark.

The necessary machinery for peat plants in Denmark, using any of the methods previously described, is manufactured by Skive Jaernstoberi og Maskinfabrik, Skive, Denmark.

*West Torup, Sweden.*—The method and plant used at this place have some interesting and labour-saving arrangements. The plant is constructed by Th. Ekholm and made by Hesseholms Mekaniska Verkstads Aktiebolag, Hesseholm, Sweden.

This plant was included in the tests of different peat machinery made by the Swedish government in 1903.\*

The plant, see Plate 17 and Fig. 45, consists of a 19 h.p. locomobile placed on a truck H movable on the same rails as the peat plant proper E. This latter consists of an elevator D, pulp machine, bin, pump and transport arrangement all placed on one and the same truck. The two trucks were moved by lever arrangements.

The elevator D is a side elevator constructed as shown in Plate 17. Its lower part, some 10 feet in length, is made horizontal and follows the bottom of the working trench. The workmen employed for digging the peat, consequently, do not need to lift the material, which is a great advantage, and the quantity of peat dug out per man per day is thereby greatly increased. A disadvantage with this method, however, is that peat from the different layers of the bog cannot be thoroughly mixed in the elevator, as the upper layer has first to be thrown down and so on with each layer in succession, resulting in a fuel of different composition and irregular quality. The lower part of the

---

\* Meddelanden fran Kungl. Landtbrukstyrelsen No. 7, year 1904.

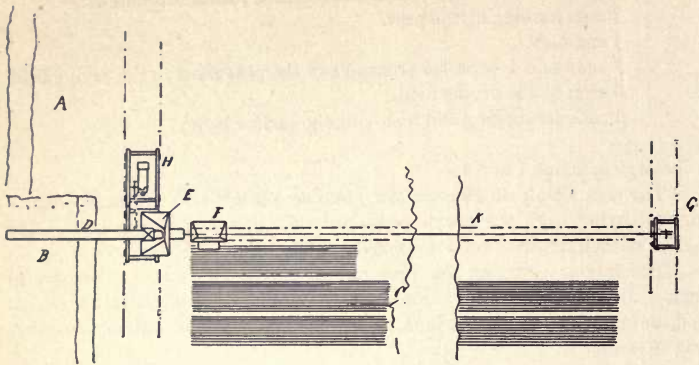


FIG. 45—Peat Plant at West Torup, Sweden.

elevator can be raised or lowered by means of a hand-winch, allowing a working depth of up to 13 feet. When the plant is moved, the elevator is raised to such a height that stumps of trees or similar obstacles do not interfere.

The material brought up with the elevator is dumped into the pulping machine where sufficient water is added. From this machine the peat porridge runs down into a bin placed underneath, from which it is tapped into a car F and transported to the drying field.

This car runs on a portable track K and is hauled back and forth by means of a winch and cable. The cable runs over a pulley placed on the anchor truck G, which is movable on rails laid down on the further side of the drying field and parallel to the working trench.

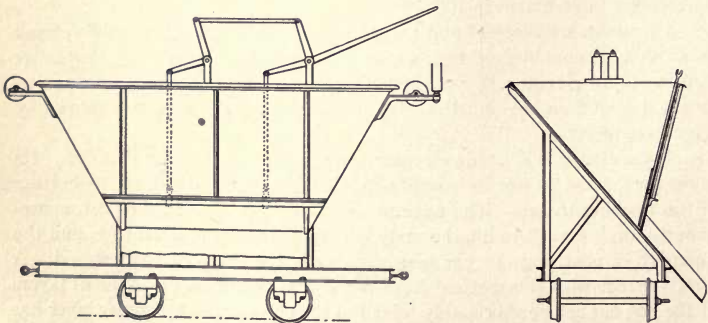
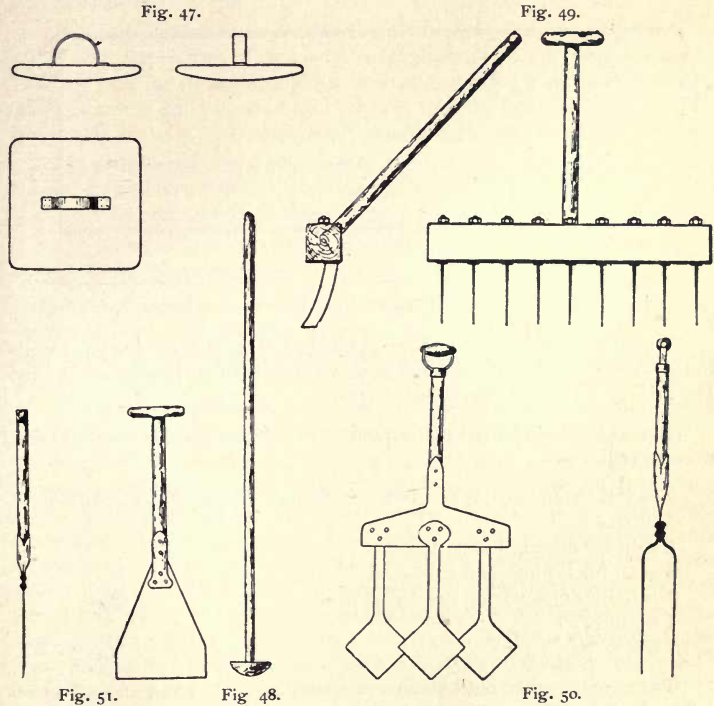


FIG. 46—Car for transport of pulped Peat at West Torup, Sweden.

The car used, see Fig. 46, holds about 2 cubic yards of the peat porridge. It is emptied by raising the lower part of the shorter side, which is easily done by a lever arrangement.

Where drying conditions are favourable and the area of the drying field small, the peat porridge is run out in a thick layer, which is made more compact by tramping, and when sufficiently dry is cut into suitable pieces. The workmen tramping the peat mass have square pieces of wood, see Fig. 47, fastened



Tramping and Cutting Tools used at West Torup, Sweden.

to their feet and also pound the mass with the wooden tool shown in Fig. 48. When the mass is sufficiently dry and compact, it is cut into suitable pieces with the tools shown in Figs. 49-51. These pieces are piled on top of each other in rows about  $1\frac{1}{2}$  feet in height. They are afterwards repiled and at last piled up in the usual conical heaps. This method, although common in Holland and some parts of Germany, is not much used in Sweden.

In Sweden the peat mass is laid out in a thinner layer, about 4 inches in thickness. The method then employed is as follows:—

The peat porridge is tamped from the car into a frame made of boards, see fig. 52, 23.1 feet long, 6.6 feet wide and 4 inches high. The frame has a handle at the front end and 15 wooden knives 4 inches apart at the other end. When it has been filled with the peat porridge, the front end is lifted up and the frame drawn forward its own length. The wooden knives at the other end then divide the mass into 16 rows, which are afterwards cut in pieces of suitable length. The drying of the peat bricks is done in the usual manner.

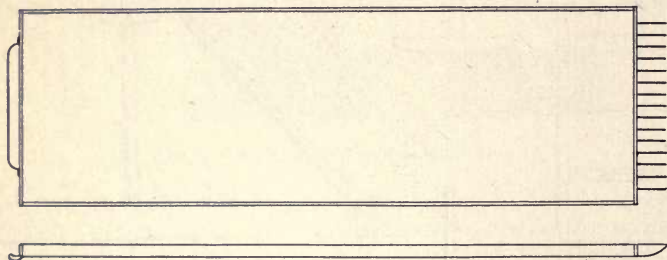


FIG. 52—Peat Moulding Frame at West Torup, Sweden.

The price of the Ekholm peat plant, inclusive of truck for locomobile, transport car, 500 feet of rails and anchor truck, is f.o.b. Hesselholm \$1,485. The price of a 19 h.p. locomobile is \$1,040.

During the test referred to, the method of working and the result obtained were as follows:—

The test lasted two days or during 20 hours. The men employed were:—  
 1 foreman,  
 3 men for digging the peat,  
 1 man for loading and transport,  
 1 man for unloading on the drying field,  
 1 engineer,  
 1 helper.

The trench worked out had an average width of 21.1 feet and a depth of 6.6 feet. When the peat had been dug out to a distance of 6.9 feet in front of the elevator, a groove was dug to fit the elevator and the plant moved this distance. The peat left behind was then thrown in, with the exception of a narrow wall, which was left in order to keep back the water in the trench.

During the test 322 cubic yards of raw peat were dug out from the trench, which with the water added in the pulping machine made 416 cubic yards of peat mass laid out on the drying field.

The raw peat contained 11.13% and the pulped peat 9.09% of dry peat substance.



The time required to load, transport to the drying field, unload and transport the car back to the plant, the greatest distance from the plant being 462 feet, was only 3-3½ minutes.

The time required to move the plant and tracks, for which all the men were required, was 20 minutes each time.

Assuming that one cubic yard raw peat contains 187 lbs. dry peat substance, or  $187 \times \frac{4}{3} = 249$  lbs. air-dried peat with 25% moisture, the 322 cubic yards dug out would be equal to 40 tons air-dried peat, or a production of 20 tons per day of 10 hours.

The power required to operate the plant during the test was 9.15 h.p. and the locomobile used of 19 h.p. is, therefore, sufficient for every emergency. The fuel used for steam raising was ordinary air-dried peat containing 27% moisture and 4.7% ash, and had a calorific value of 3,500 cal. per kg.=6,300 B.T.U. per lb. The fuel consumption was 12.8 lbs. per h.p. hour.

The conclusions of the commission were, that this plant is only suitable for well drained bogs, which are comparatively free from stumps, with a depth of at least 6-7 feet and containing well humified peat.

The prices of peat fuel and coal at Hesselholm were respectively \$2.30 and \$4.70-\$4.90 per ton.

*Ipendam, Holland.*—A practical and successful method for the working of the undrained bogs in Holland has been introduced by N. van Breemen of Haarlem. The bogs are, as a rule, free from roots and stumps of trees, which is a necessary condition.

The machinery, which is placed on a floating iron barge, consists of one or two cutting machines, pulping machine, elevators and locomobile.

The cutting machines are placed in the front of the barge and consist of rectangular frames with sharp edges. The bottom is provided with two large valves, which open up when the frame is pressed down and close by the weight of the peat when it is lifted up. The frame or frames are lowered and raised by means of racks and pinions. The peat lifted up is drawn out of the frame with a rake and falls directly down into the pulping machine, where it is mixed with water. The pulped mass is transported by means of an elevator to a long steel channel supported from the barge. Here it is mixed with more water and run out on the surface of the bog in a trough made by walls of loose boards. The power required to operate the plant is 20 h.p.

The peat porridge run out in the trough has a thickness of about two feet, but when left 24 hours most of the additional water has run away, and the thickness diminished to about half. The mass is then solid enough to retain its shape and the walls are moved forward.

In order to make it still more compact, it is tramped by two men, using square pieces of wood on their feet, see Fig. 47, and the tool shown in Fig. 48. This process is repeated after 2, 3 or more days, depending on weather conditions. When the peat mass is sufficiently dry, it is cut in pieces, which are dried in the usual manner.

With 10 men the production of a plant of the above description is, on an average, 82.5 tons air-dried peat per day of 10 hours.

The men are paid 3 gulden (\$1.20) per day, and the cost of production is, inclusive of all costs, interest and amortization, \$2.90 per ton.

In Holland the bogs themselves are very expensive. A bog with an average depth of 6 to 7 feet sells for 3,000 gulden per har=\$486 per acre.

The price of N. van Breemen's peat plant is \$8,000 f. o. b. Rotterdam. Mr. van Breemen also uses his cutting machines in combination with a Schlickeyesen machine (see page 59) for the manufacture of machine formed peat. In this case the raw peat is dumped into a mixing machine and from there by means of an elevator conveyed to a Schlickeyesen machine. No extra water is added, and the pulped peat leaving this machine is placed on pallets in the usual manner (see next part of this chapter) and brought to the drying field.

In Amsterdam peat fuel made from the heavy, well humified peat sells in smaller quantities for 8 gulden per 1,000 pieces, and the fuel made from the lighter varieties of peat for 7 gulden per 1,000 pieces. This is equivalent to \$5.80 per ton for the former and \$6.30 for the latter. When sold in large quantities the price is \$4.00 to \$4.40 per ton.

Peat fuel is largely used in Holland as a domestic fuel, notwithstanding the comparative cheapness of coal, which sells at about \$4.00 per ton.

*Elisabethfehn, Oldenburg, Germany.*—The plant used at this place is patented and constructed by O. Strenge, of Elisabethfehn. It consists of a mechanical excavator, which delivers the raw peat to a conveyor. The conveyor brings the peat to a mixing and pulping machine, also patented by the same inventor. During the spring and early part of the summer the plant is used for the manufacture of machine formed peat. In this case another conveyor and a device for the spreading out of the pulped peat on the drying field are combined with the plant. A plant of this character is fully described in the next part of this chapter pages 116-120. During the latter part of the summer, and until the frost starts, the plant is used for the manufacture of peat fuel belonging to the class described in this part of the chapter. The additional conveyor and spreading device are then taken off and a steel channel, 40-50 feet long, supplied with a mixing screw is inserted. The peat mass leaving the pulping machine is mixed in this channel with water and run out into a trough to a depth of 3 to 5 feet. During the winter the surface of the peat mass is kept covered by a layer of sphagnum moss in order to keep it from freezing. A plant of this description requires 12 men and has, according to the inventor, a capacity of 1,060 cubic yards of raw peat per day. The power required to operate the plant is 30-35 h.p.

The peat mass is cut by hand in the spring and dried in the usual manner. The peat fuel manufactured was well pulped, heavy and compact, and was mostly used as raw material for the peat coaking plant located at the same place. The bog was well drained and comparatively free from roots and

stumps of trees, which explains the satisfactory working and the large capacity of this plant.

The weight of one cubic yard of peat fuel manufactured by these methods is from 400 to 730 lbs., as determined by the Swedish Peat Society.

## 2.—MACHINE FORMED OR PRESSED PEAT.

This method of mixing, pulping and shaping the peat without any extra addition of water is the one chiefly employed, and is undoubtedly more suitable than the processes previously described, especially when the surface of the bog has to be used for drying field or where drying conditions are less favourable. The raw peat is, as a rule, more thoroughly mixed and pulped by the machinery employed, permitting the manufacture of a good fuel from fibrous and less humified peat.

A plant for the manufacture of machine formed peat consists of the mixing and pulping plant and appliances and arrangements for the transport and laying out of the pulped peat.

The mixing and pulping plants used are, as a rule, movable on rails close to the working trench. The transportation of the raw peat any great distance is thereby avoided, and by using the surface of the bog in the immediate vicinity of the trench as drying field the transportation of the pulped, wet peat mass is reduced as much as possible.

The width of the drying field should be such that the peat manufactured from a certain length of the trench can be laid out the same length on the drying field, so that the digging out of the trench and the laying out on the drying field keep pace with each other.

The drying field requires to be well drained, in order to facilitate drying and transportation. The methods used for drainage are similar to those described on page 23. The working trench for each plant should be as long as possible and always of such a length that when the end is reached and the plant is moved back the peat laid out at the beginning has had sufficient time to dry and be removed, when a new trench can be started. The walls of the working trench, especially in bogs of considerable depth, sometimes have a tendency to cave in, causing loss of time in moving the plant and otherwise interfering with the regular working of the process. In such bogs the weight of the plant must be taken into consideration, but as a rule a properly drained bog can easily carry the plants now employed.

A mixing and pulping plant generally consists of an elevator conveying the raw peat to a machine, where it is mechanically treated, and of a motor furnishing the required power. All these appliances are as a rule mounted on one and the same platform provided with wheels which move on rails.

These plants, as well as the methods used for transporting and laying out the peat for drying, differ considerably, but the drying work is practically the same and is done in a manner similar to that already described in the first part of this chapter.

Before entering into the details of the machinery and methods used, a few general remarks will be made.

The raw peat is, with very few exceptions, dug out of the bog by hand and thrown into the elevator, which conveys it to the peat machine. A practical mechanical excavator would naturally be of the greatest value and materially decrease the number of men required, but so far no such apparatus has been invented which has proved satisfactory in bogs where roots and stumps are plentiful, and the construction of such an excavator is undoubtedly an exceedingly difficult problem. In bogs free from roots and stumps mechanical excavators are quite possible. To such apparatus belong the Dolberg and Van Breemen cutting machines previously described and mostly used in undrained bogs, O. Strenge's machine (see page 120), and the excavator invented by Schlickeysen (see page 64). In most cases, however, the bogs contain numerous roots and stumps of trees and hand labour has to be used. The spades employed for this purpose differ in shape in different localities, but those with a large, heart-shaped blade are chiefly used.

*The elevators* are either side or end elevators. A side elevator is placed at right angles to the direction in which the peat plant is moved, an end elevator in the same direction.

With a side elevator a better foundation for the peat plant is obtained, the trench being dug out in steps parallel to the direction in which the plant is moved, see Fig. 68, and not vertical. The objections to the side elevator are that the digging must chiefly be done from one side only, that they are in the way when the plant is moved and that they cannot conveniently be made long enough to allow the employment of a greater number of men, or for very deep bogs, when a larger production could be obtained.

With an end elevator, see Fig. 69, a wider trench can be worked, the digging is done on both sides, permitting the employment of more men, and when the plant is moved this elevator does not interfere to the same degree. The larger peat plants, especially in Sweden and Russia, as a rule have end elevators. The carrying part of the elevator chain with its pallets conveys the raw peat to the hopper of the peat machine.

*The peat machine.*—For the mechanical treatment of the raw peat quite a number of different machines have been invented. The main object is to mix and pulp the peat so that a homogeneous and compact fuel is obtained. The requirements of a first-class machine are as follows:

1. Simple and strong construction, with every part easily accessible.
2. Large capacity.
3. Thorough treatment of the peat, and so constructed that roots and fibres are pulped and not twisted around the rotating parts of the machine, causing stoppages and loss of time.

The machine which best fulfils these requirements is undoubtedly the Anrep machine, chiefly used in Russia, Sweden and Norway. The German machines are, as a rule, of smaller capacity and of more complicated construction.

The more thoroughly the raw peat is mixed and pulped, the more it shrinks during this process and the more homogenous and solid is the product obtained. The shrinkage is naturally greater for fibrous and less humified peat if suitably treated than for well humified or fat peat, which in its raw state is less porous.

A peat machine consists of a cast iron mantle, with or without fixed knives, in which one or two shafts provided with knives or screw threads rotate. The raw peat is more or less thoroughly mixed, kneaded or pulped, pressed forward to a mouthpiece, and leaves the machine as a continuous band, which is cut in suitable lengths. The mouthpiece has one, two or three openings of rectangular cross-sections and is either placed with its centre line coinciding with the centre of the machine or making an angle with this line.

The peat bands leaving the machine are taken up on pallets of suitable lengths, loaded\* on special cars and transported to the drying field. A short table supplied with rollers facilitates the transportation of the pallets from the machine to the cars.

The first peat machines of practical value were invented by C. Schlickeysen and R. Dolberg of Germany. In later years a number of other machines have been invented, of which some are superior to the improved machines at present manufactured by these firms, but others are not.

*C. Schlickeysen's Machines.*—These machines are at present manufactured by the Rixdorfer Maschinenfabrik (formerly C. Schlickeysen), Rixdorf, Berlin, Germany.

The first machine manufactured by Schlickeysen in 1859 was made with a vertical shaft provided with knives in the same manner as a brick machine. The raw peat was fed in at the top, pressed out through the mouthpiece at the bottom and cut in suitable lengths. One or more horses were used for the operation of this machine. The production of such a machine was small and a few years later machines with horizontal shafts and larger capacity were constructed. These machines were suitable in bogs containing well humified peat comparatively free from roots and fibrous peat, but where this was not the case the peat was not sufficiently pulped. Schlickeysen has, therefore, in later years invented catching and tearing apparatuses, which are placed in the feed hopper to the machine and greatly improve the quality of the peat fuel manufactured. These apparatuses can be removed independent of each other. If the peat treated requires more or less intensive mixing and pulping, a number of these apparatuses are installed, so that the machine can be made suitable for the treatment of different classes of peat.

The construction of this machine is shown in Figs. 53-57.

The raw peat brought up by the elevator (see Figs. 56 and 57) is dumped into the feed hopper, where it falls on the catching and tearing apparatuses shown in Figs. 53 and 54. These apparatuses consist of two cranked shafts

\* By newer inventions, described later, the transportation to the drying field is done in a different manner.

Fig. 53.

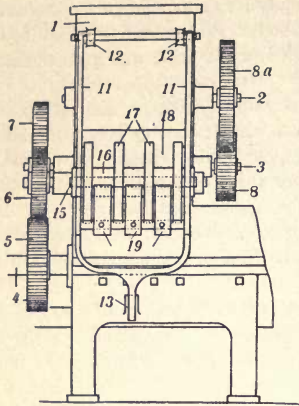
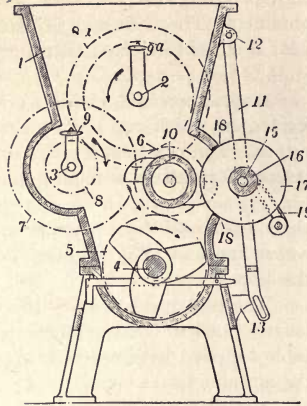


Fig. 54.



Schlickeysen's Peat Machine No. 3.

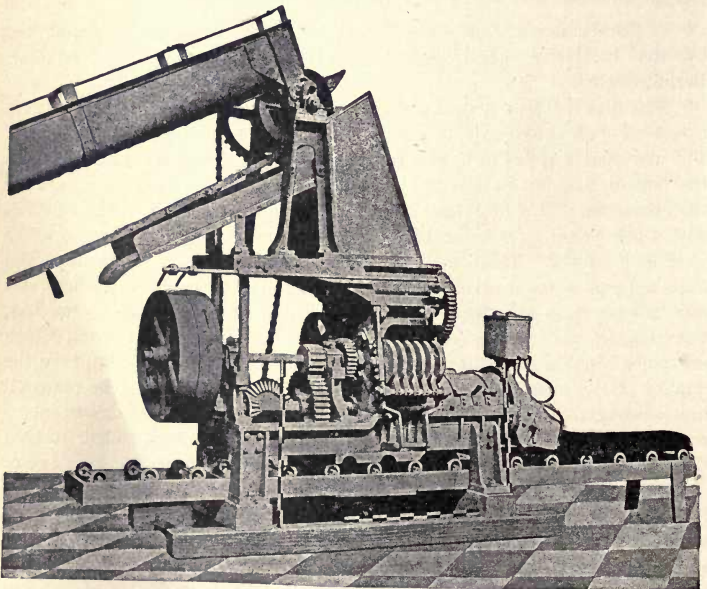


FIG. 55—Schlickeysen's Peat Machine No. 3.



FIG. 56—Schlickeysen's Peat Machine with end elevator.

(2) and (3), which turn in opposite directions like a rolling mill, the lower one at the same time revolving against a gear roller (10). The peat is torn to pieces by the cranks and thrown against the gear roller, which furthermore mixes and pulps it. The gear roller throws it on and between the wings or knives on the shaft (4) which with its cast iron covering and mouthpiece constitutes the main part of the machine. The knives on the shaft (4) are placed in the shape of a screw thread and have sharp edges, cutting against fixed steel bars inserted through the cover (see Fig. 54). These steel bars are easily accessible from the outside and can be changed without stopping the machine. The shaft makes 80 revolutions per minute. The peat mass is again mixed in this part of the machine, kneaded and pulped and forced toward the mouthpiece, which in most of Schlickeysen's machines has three openings.

The raw peat fed into the hopper and pressed down by the cranks would result in the jamming of the machine if too large a quantity was put in. In order to prevent this, the machine is provided with a special arrangement acting as a safety device in the following manner: If the overfeeding is so great that the receiver (4) cannot absorb and treat all the material pressed down, the gear roller (10) throws the surplus material directly from the lower crank (3) toward the opening (18) in the hopper. This opening, which extends over the whole width of the hopper, is usually partly closed by a balanced disc roller hanging in front and consisting of thin discs (17) connected with the nave (16) turning on the shaft (15). The teeth on the gear roller (10) pass between the discs (17).

The elevator is either made as an end or side elevator, see Figs. 56, 57, and consists of a half cylindrical iron channel, in which the chain with its pallets runs. The lower part is carried up by a frame movable on wheels.

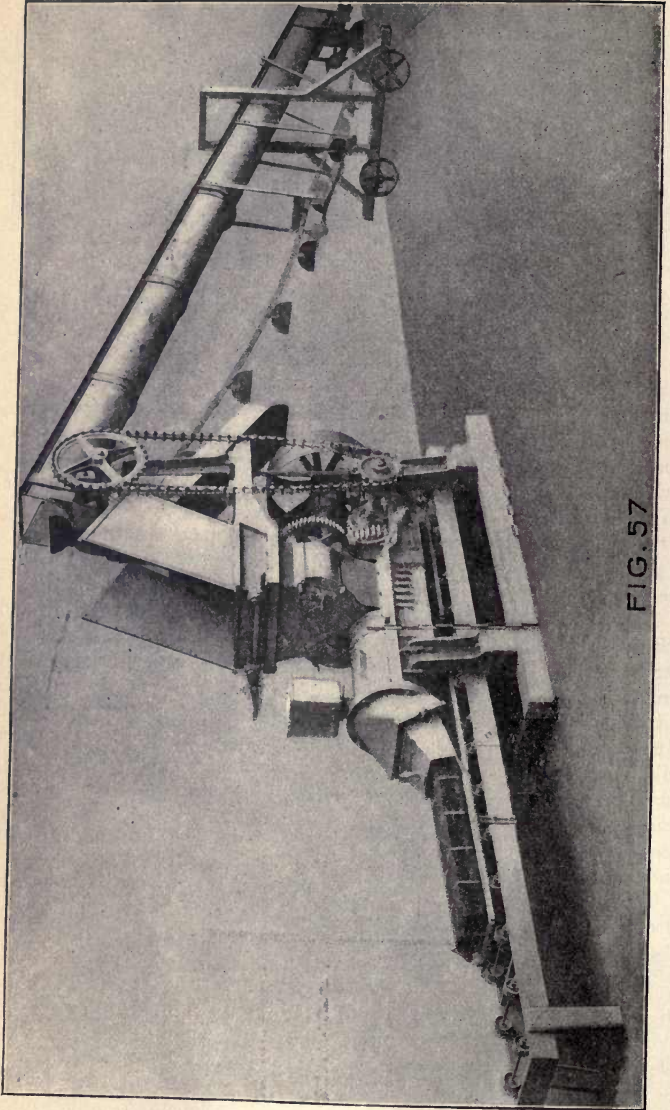


FIG. 57

FIG. 57—Schlickeysen's Peat Machine with side elevator.



PLATE 18.



Schlickeysen's Peat Excavator.



The firm manufactures these machines in three sizes, the weights, prices and capacities of which are given in the following table.\*

No.	CAPACITY PER HOUR.						Approximate weight of machine. Lbs.	Approximate weight of elevator. Lbs.	Price of machine f. o. b. Berlin. Marks.	Price of elevator f. o. b. Berlin. Marks.	Power required. h. p.
	MACHINE PEAT.		Volume of air-dried peat. Cub. yards.	Weight of air-dried peat. Lbs.	Raw Peat.						
	Pieces of 0.528 gallons.	Cub. yards.			Cub. yards.	Cub. yards.					
1.....	800	2.09	0.65	880-1200	3.14	2,200	.....	1,000	....	3-5	
2.....	4000	10.46	3.14	3960-5280	15.70	3,520	3960 (33 ft. long)	2,400	1400	6-8	
3.....	7000-10000	19.61	5.88	6600-9900	27.35	8,800	3960 (33 ft. long) 5280 (50 ft. long)	4,000	1500	10-12	

\* Obtained from the catalogue of the firm.

The above prices include only the peat machine itself, truck motor, cars, rails, etc., being additional. A complete plant (see Fig. 56) with No. 3 machine costs about 18,000 marks. The number of men required for such a plant is:—

- 2 men for levelling and stump raising,
- 5 men for digging the raw peat,
- 1 man attending to the pallets,
- 1 man cutting the peat in suitable lengths.
- 2 men for loading pallets on cars,
- 4 men for transportation of cars,
- 2 men for unloading.

—  
Total: 17 men

The figures given in the above table for the production are undoubtedly much too high. At Beuerberg, Bavaria, a Schlickeysen machine was in operation run by a 20 h.p. electric motor. The capacity of this machine with 14 men was on an average 22 tons air-dried peat per day of 10 hours.

The Schlickeysen machine delivers a homogeneous and compact peat fuel, but the construction is complicated, repairs often necessary and the capacity comparatively small, which are probably the reasons why these machines are very little used.

*Schlickeysen's Peat Excavating Machine*:—A mechanical excavator was exhibited by Schlickeysen at the peat exhibition in Berlin, 1904. His idea was to have the excavator with its necessary machinery placed on a movable truck and preferably operated by an electric motor. The material excavated, which should be sufficient to supply 2 or 3 large peat machines, was dumped by means of a chute into dumping cars running on a portable track on the side of the excavator. This machine could excavate over 36 cubic feet per minute, and during the same time the plant was moved forward about 3.5 feet.

The construction is shown in Fig. 58 and Plate 18.

In bogs free from roots and stumps such a machine would probably do satisfactory work, but where this is not the case the probabilities are that no saving would be obtained by its employment. The objection with this excavator is, furthermore, that a great amount of peat is left in the bog. The machine only excavates a triangular trench, and when put to work in its next working line a triangular bank is left standing in the bog.

As far as known, this excavator has up to the present not been installed at any peat plant.

*R. Dolberg's machines*.—These machines are manufactured by the R. Dolberg Maschinen und Feldbahn Fabrik Aktiengesellschaft, Rostock i. M., Germany.

The Dolberg machine is probably the one which is mostly used in Germany. The principal parts of this machine are two parallel shafts rotating against each other, and provided with screw threads, see Fig. 63, made up of

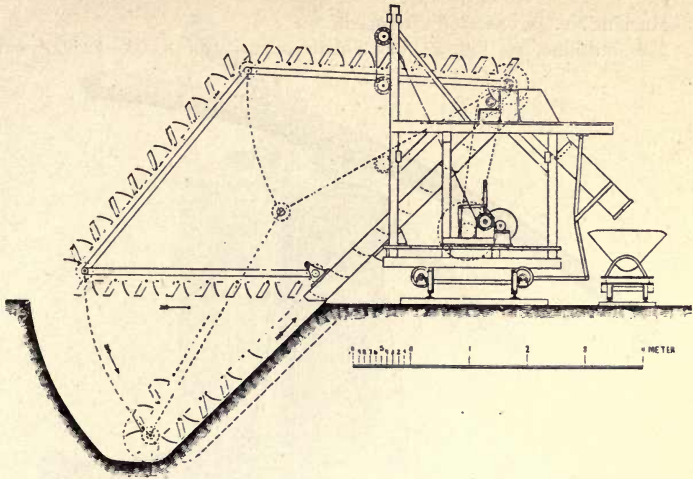


FIG. 58—Schlickeyesen's Peat Excavator.

interchangeable quadrants. The thread on one shaft passes between that on the other shaft, whereby the peat material is mixed and kneaded, during its movement towards the mouthpiece of the machine. Roots and fibres are not cut or pulped in a machine of this construction and in cases where the peat contains such material, stoppages are frequent and the work interrupted during the cleaning of the machine. These roots and fibres twist themselves around the shafts and prevent the movement of the material towards the mouthpiece. In bogs containing well humified peat free from roots and fibres the Dolberg machine works satisfactorily.

Machines exactly similar to the Dolberg machine or with very slight alterations are also manufactured by the following firms:—

- A. Heinen,\* Varel, Oldenburg, Germany.
- Sugg & Co., Munich, Bavaria, Germany.
- Gebrüder Stützke, Lauenburg, in Pom., Germany.
- Jaehne & Sohn, Landsberg, a. W., Germany.

In order to be able to treat more fibrous peat, Dolberg manufactures a machine (see Fig. 65) in which a certain number of the quadrants forming the screw threads are omitted. The sharp edges of the remaining quadrants then cut and pulp the peat to some extent. He also manufactures machines in accordance with the Anrep patent (see page 77) where the shafts are supplied with knives (see Fig. 67) revolving against fixed knives placed in the cover. In these machines the peat is more thoroughly cut and pulped.

The different machines manufactured by R. Dolberg are:

\* This firm also manufactures machines of different construction, see pages 73-76.

Machine No. 3a, operated with one horse.

This machine, see Fig. 59, has a daily capacity of 8,000—12,000 peat

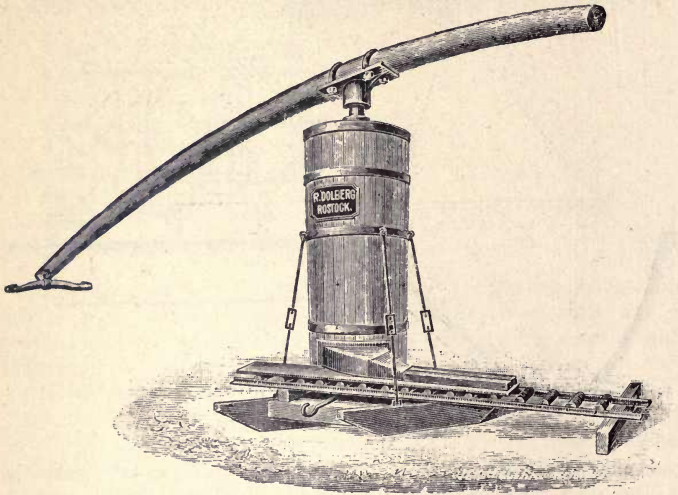


FIG. 59—R. Dolberg's Peat Machine No. 3. a.

bricks of the dimensions 4 x 4 x 8 inches = 128 cub. inches.

Machine No. 2 operated with two horses.

This machine, see Figs. 60 and 61, has a daily capacity of 18,000—25,000 peat bricks of the above dimensions.

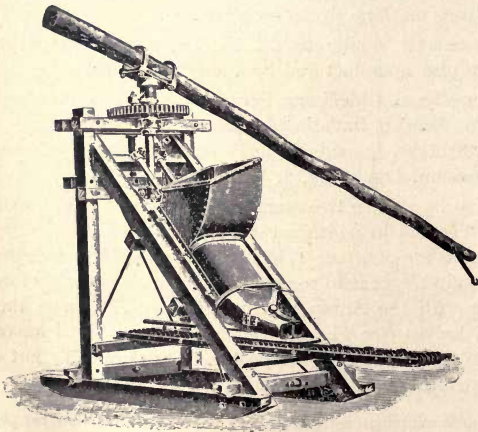


FIG. 60—R. Dolberg's Peat Machine No. 2 (exterior).

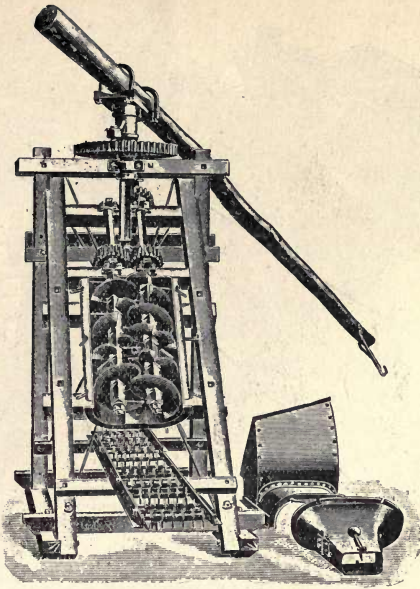


FIG. 61—R. Dolberg's Peat Machine No. 2 (interior).

Machine No. 1a, operated with a motor of 4—6 h.p.

This machine, see Figs. 62 and 63, has a daily capacity of 30,000—40,000

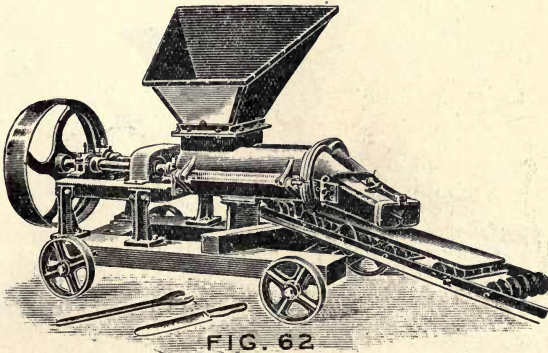


FIG. 62

FIG. 62—R. Dolberg's Peat Machine No. 1a (exterior).

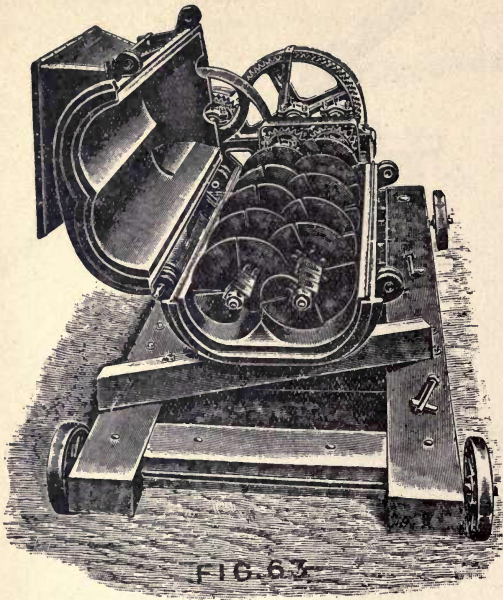


FIG. 63—R. Dolberg's Peat Machine No. 1a (interior).

peat bricks of the above dimensions. The shafts make 70 revolutions per minute. Diameter of pulley 26 inches.

Machine No. 1b, operated with a motor of 15-18 h.p.

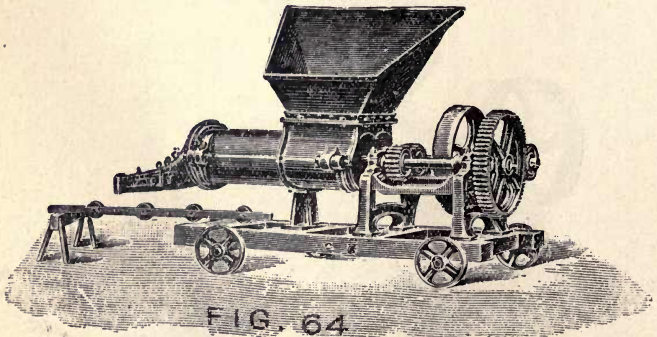


FIG. 64—R. Dolberg's Peat Machine No. 1b (exterior).



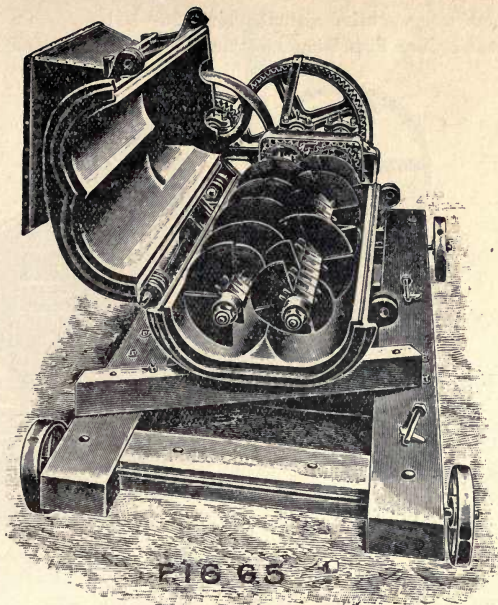


FIG. 65—R. Dolberg's Peat Machine No. 1b (interior).

This machine, see Figs. 64 and 65, has a daily capacity of 60,000—80,000 peat bricks of the above dimensions. The shafts make 90 revolutions per minute. Diameter of pulley 25 inches.

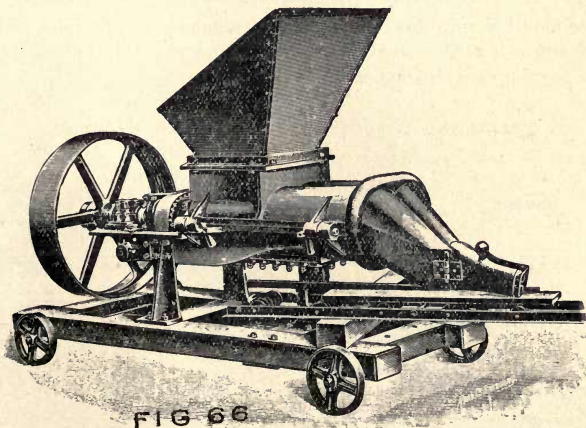


FIG. 66—R. Dolberg's Peat Machine No. 1c (exterior).

Machine No. 1c, operated with a motor of 25—30 h.p.

This machine, see Figs. 66 and 67, has a daily capacity of 60,000—80,000

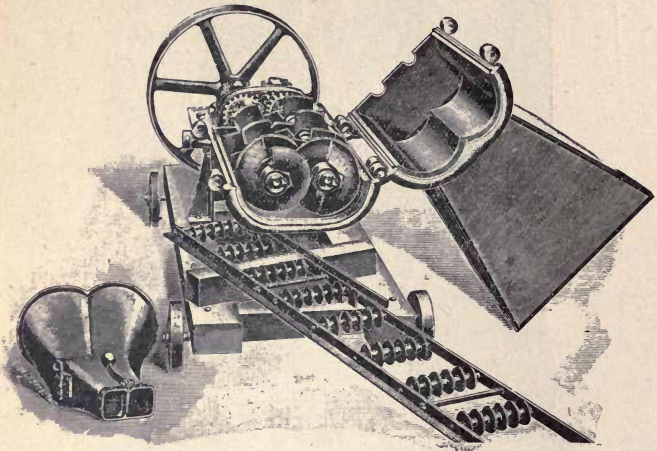


FIG. 67—R. Dolberg's Peat Machine No. 1c (interior).

peat bricks of the above dimensions. The shafts make 270 revolutions per minute. Diameter of pulley 36.8 inches.

The two latter machines, Nos. 1b and 1c, are always combined with elevators which bring up the raw material to the feed hopper.

The construction of the elevator, which is either made as a side elevator, see Fig. 68, or as an end elevator, see Fig. 69, is clearly shown in these figures.

The mouthpiece to the machines, as a rule, has two openings, divided by a knife, which is easily removed if stoppages occur. Mouthpieces with one or three openings are also manufactured if desired.

#### PRICES AND WEIGHTS OF THE DOLBERG MACHINES.

Number.	Approximate weight. Lbs.	Price. Marks.	Price. Dollars.	Approximate capacity per day air-dried peat. Tons.
3a.....	1,485	550	132	3.52—5.28
2.....	2,156	875	210	7.92—11.00
1a.....	1,122	620	149	13.20—17.60
1b.....	2,354	950	228	26.40—35.20
1c.....	2,640	1560	375	26.40—35.20
33 feet long chain elevator with driving apparatus.....	2,486	1165	280	

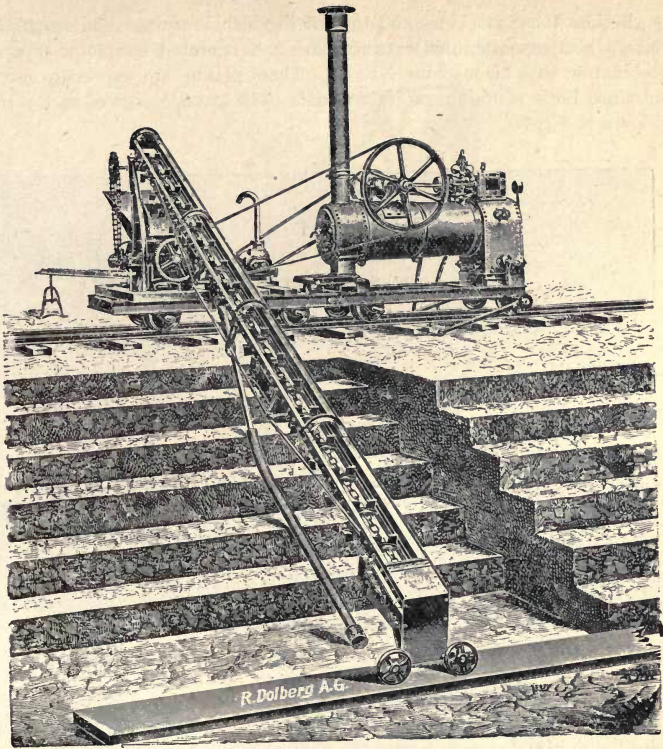


FIG. 68—R. Dolberg's Peat Plant with side elevator.

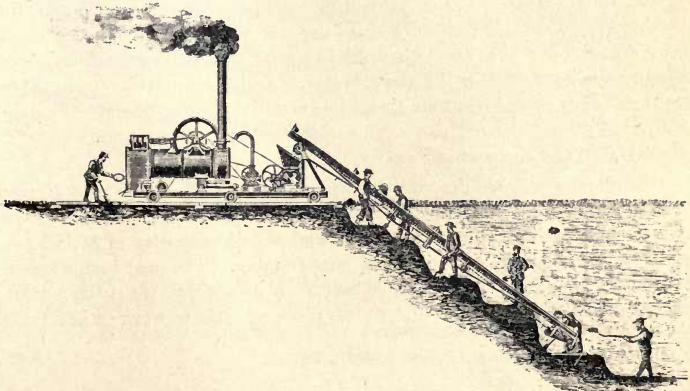


FIG. 69—R. Dolberg's Peat Plant with end elevator.

Besides these machines and the cutting machines described on page 29, Dolberg also manufactures cutting machines, operated by motor power in combination with his machine No. 1b. These plants are especially used in undrained bogs, containing suitable peat. The arrangement of such a plant is shown in Fig. 70.

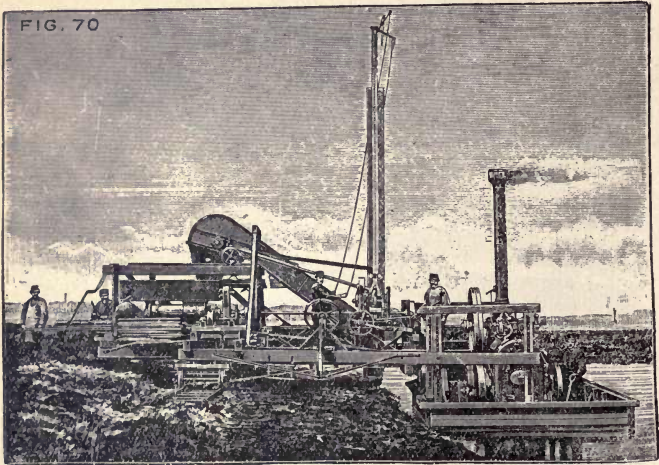


FIG. 70—R. Dolberg's Peat Cutting Machine for motor power.

The cutting machine, elevator and peat machine are placed on a bridge, supported at one end by a truck movable on rails, and at the other by a barge floating in the trench already worked out. The barge also carries a locomobile or some other kind of motor, furnishing the power required to operate the cutting machine, elevator and peat machine. The cutting machine is of the same construction as the one described on page 29, but of larger dimensions. The peat block lifted up by the cutting machine is conveyed to the peat machine by the elevator. A cutting machine operated by steam or other power has four times the capacity of one operated by hand, and for the attendance of this machine, elevator, peat machine and locomobile only two men and one engineer are required.

Plants of the above description are in operation at Turew near Kosten, Posen, at Samter in the same province, and at Korsow in Galicia, Austria. At the last mentioned place\* the plant had a daily capacity of 80,000 peat bricks equivalent to 44 tons air-dried peat per day. The peat bands leaving the peat machine were cut in suitable lengths by an automatic cutting machine constructed by Dolberg, and which at this place was said to work satisfactorily.

\* Svenska Mosskulturforeningens tidskrift, 1905.

The construction of this machine is shown in Fig. 71. Very few of these are in operation, however, and the firm itself considers them less satisfactory.

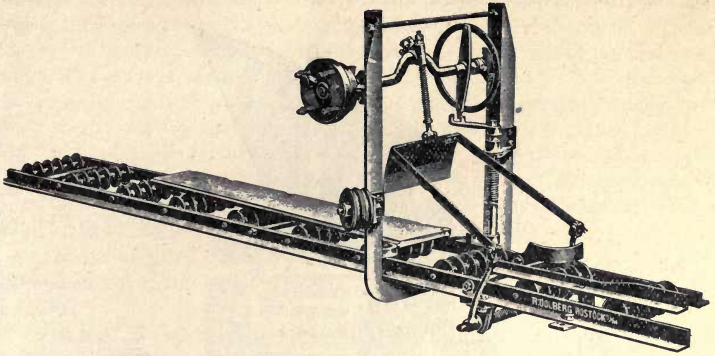


FIG. 71—R. Dolberg's Automatic Peat Cutting Machine.

*A. Heinen's machines.*—These machines are manufactured by A. Heinen, Maschinenfabrik und Eisengießerei, Varel in Oldenburg, Germany.

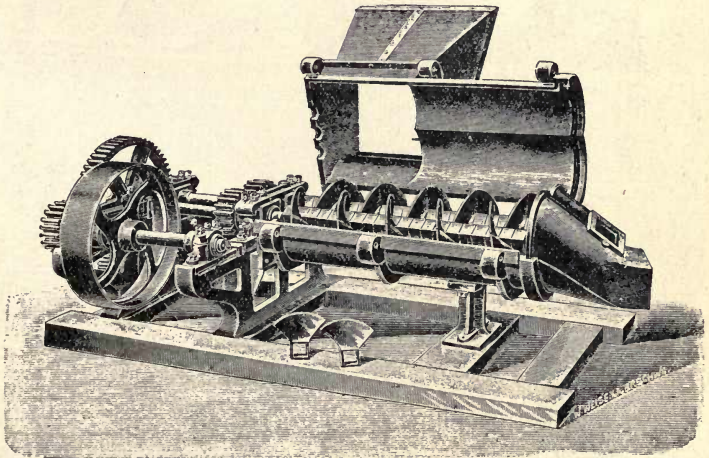


FIG. 72—A. Heinen's Peat Machine Nos. T. 1 and T. 2 of Dolberg type

The older machines, manufactured by Heinen, see Fig. 72, in two different sizes (numbers T1 and T2), are practically the same as the Dolberg machine shown in Fig. 63, and are suitable for well humified peat free from roots and fibres.

In order to be able to treat fibrous peat, Heinen has combined these machines with apparatus for mixing, tearing and cutting the raw peat. His machine, No. T 2 W, is shown in Figs. 73-75.

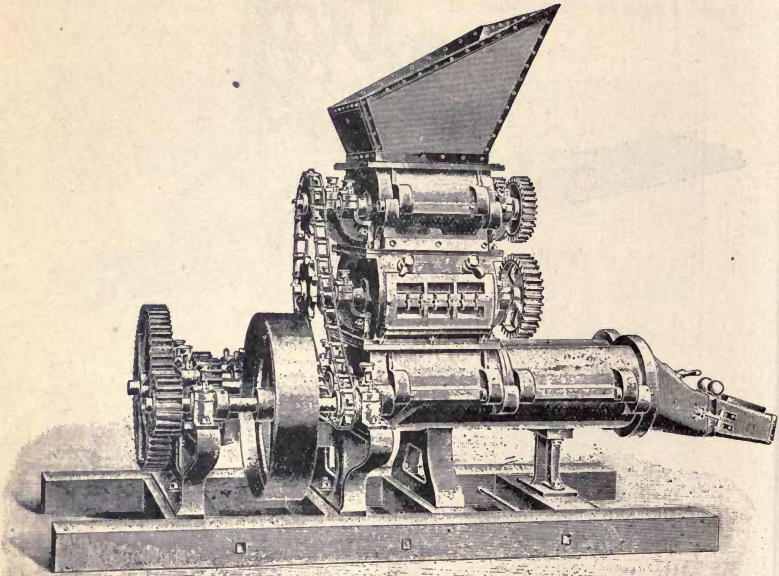


FIG. 73—A. Heinen's Peat Machine No. T. 2, W.

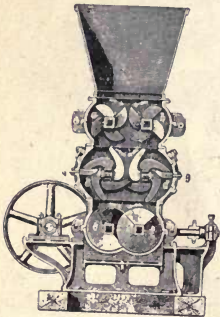


FIG. 74.

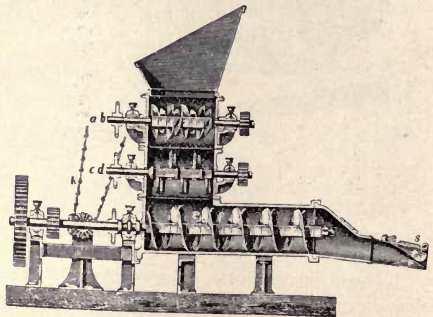


FIG. 75.

A. Heinen's Peat Machine No. T. 2, W.

In the feed hopper to the machine (see Figs. 74, 75) are two shafts, a and b, provided with mixing wings, which mix and tear the raw peat. Underneath these shafts are two other shafts, c and d, provided with knives, which revolve against fixed knives, g, inserted through the walls. These knives cut and pulp the peat before it enters the lower part of the machine, where it is again mixed and kneaded by the screws e and f. The two upper shafts, a and b, are each made in two parts, joined at the center and the two lower shafts, c and d, are accessible through the movable side plates, in which the fixed knives are secured. The lower part of the machine is also easily accessible; by removing the bolts, m m, the upper parts of the cover can be lifted up. The knife or knives, r, in the mouthpiece of the machine are easily lifted up by the handle, s, if this part requires to be cleaned.

Any of the pairs of shafts with their knives can be removed or replaced independent of the other, so that the machine can work with only one pair, if desired.

The machine is well constructed, every part easily accessible, and delivers a homogeneous and well pulped peat, but naturally is somewhat complicated.

In localities where the area of the drying field is very limited, a specially constructed mouthpiece and loading table have been introduced by Heinen.

The construction of this apparatus is shown in Fig. 76.

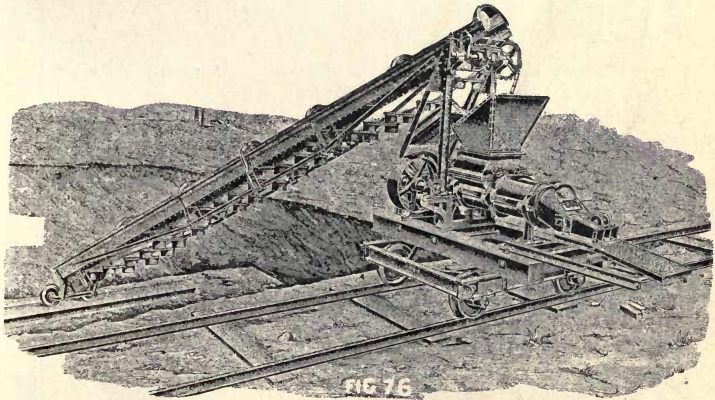


FIG. 76—A. Heinen's Peat Machine No. T. 2, with Mixing Apparatus, special Mouth-piece, Loading Table and Elevator.

The mouthpiece has three openings, 4 x 4.4 inches, and is supplied with two cutting wheels, as shown in the figure. Instead of the usual rolling table the machine is supplied with a short inclined table made of narrow steel plates, which are kept wet, in order that the peat bands may move easily and not stick to the plates. The peat is cut in suitable lengths, taken up on trays at the end of the table, carried to the drying field and placed on end for drying.

The elevators manufactured by Heinen are shown in Figs. 76 and 77 for his machines Nos. T 1 and T2.

The Heinen machines are used at a number of peat plants in Germany and are, as a rule, satisfactory to the owners of these plants. Machine No. T1 has a daily (10 hours) capacity of 23,000—31,000 peat bricks, equivalent to 12.65—17.05 tons, with 13 men.

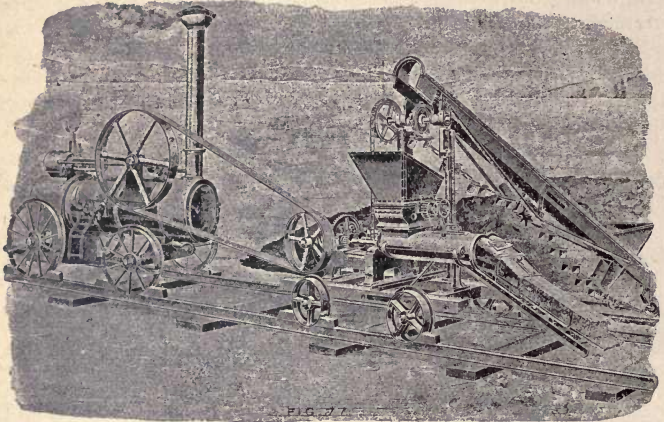


FIG. 77—A. Heinen's Peat Machine No. T. 1, with Mixing Apparatus, Rolling Table and Elevator.

Machines No. T2 and T2 W have a daily (10 hours) capacity of 46,000—61,000 peat bricks, equivalent to 25.30—33.55 tons, with 16 men.

The price of machine No. T1, with one mixing apparatus and an elevator 20 feet long, is f.o.b. Varel 2,000 marks—\$480.

The price of machine No. T2 W with two mixing apparatuses and an elevator 33 feet long is 4,250 marks—\$1,020.

*L. Lucht's Machines.*—These machines are manufactured by L. Lucht Maschinenbau-Anstalt und Eisengiesserei in Kolberg, Germany.

The machine, see Figs. 78 and 79, has only one shaft rotating in a cylinder

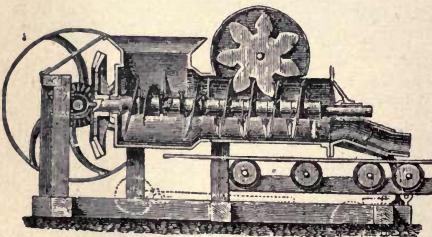


FIG. 78.

L. Lucht's Peat Machine.

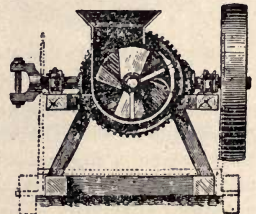
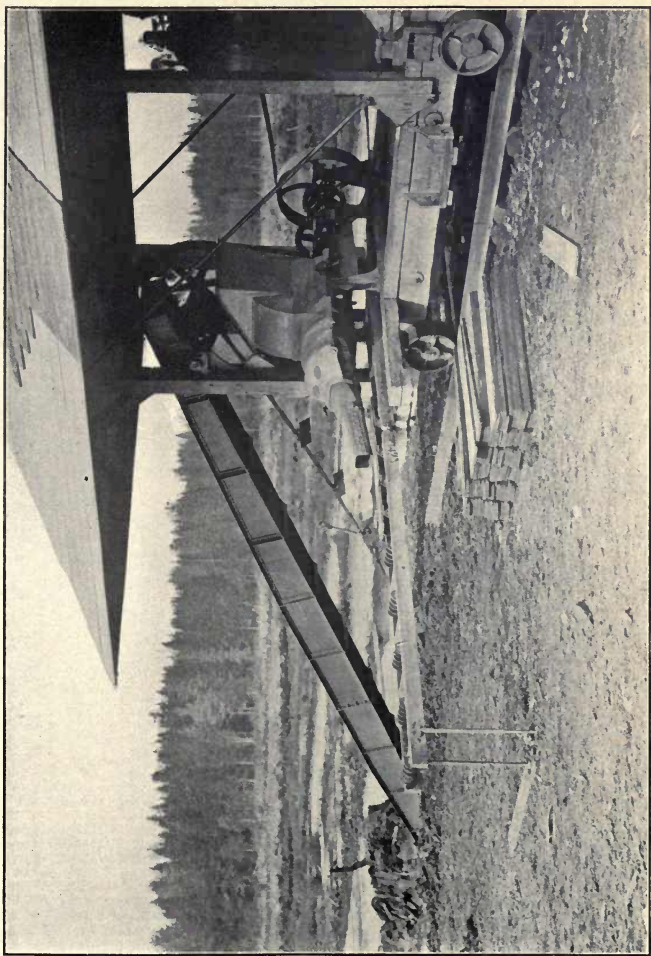


FIG. 79.



PLATE 19.



Anrep Peat Plant, Bissereva, Russia.



which is of larger diameter at the feeding end. In this wider part the shaft is supplied with knives, which rotate against fixed knives placed in the walls and with part of a screw thread. In the narrower part of the cylinder the shaft is supplied with a continuous screw thread, in which a spur wheel rotates as shown in Fig. 78. The object of this wheel is to keep the screw clean and to assist in moving the peat mass towards the mouthpiece.

Only a few of these machines are in operation and no special advantages are gained by this construction.

*A. Anrep's Machines.*—These machines are at present manufactured by Abjörn Anderson's Mekaniska Verkstads Aktiebolag, Svedala, Sweden.

The Anrep machines are, as has been said previously, those which best fulfil the requirements of a first-class peat machine.

The older machines constructed by Anrep, which are still largely used, especially in Russia, had two parallel shafts rotating against each other, see Figs. 80, 81. These shafts are provided with knives placed in such a manner that they form a screw-thread. The knives on one shaft rotate in the spaces left by the knives on the other shaft in a manner similar to the screws in the Dolberg machine. Fixed knives are placed in the bottom and also in the top cover, which are so constructed that they act as bearings for the shafts.

According to A. Anrep's patent, the rotating knives shall rotate against the two edges of the fixed knives. By this construction no spaces occur on the rotating shafts in which roots and fibres can twist around and necessitate stoppages for cleaning. All the material put in is thoroughly pulped and forced towards the mouthpiece, close to which the shafts are provided with screw threads.

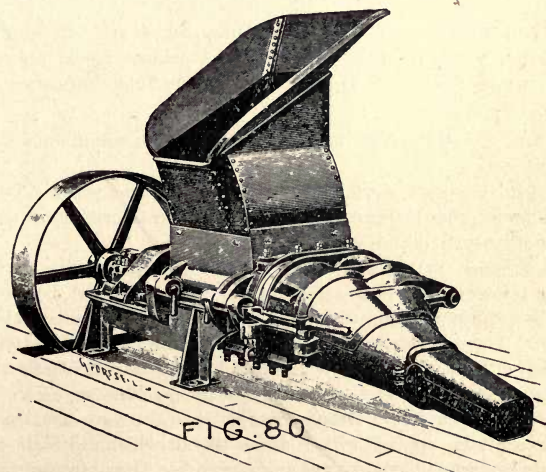


FIG. 80—A. Anrep's Peat Machine with two shafts (exterior).

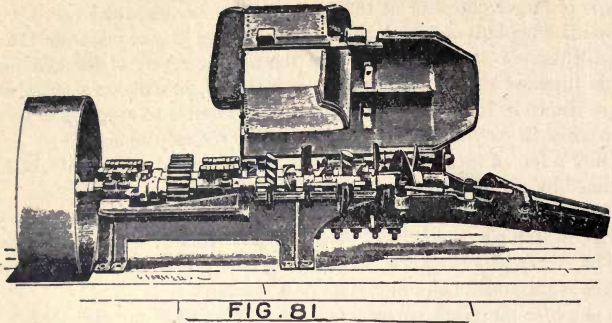


FIG. 81—A. Anrep's Peat Machine with two shafts (interior).

The capacity of these machines is from 40 to 60 tons per day.

In machines of this construction the peat mass is more thoroughly pulped than in a Dolberg machine. The construction is simpler than in the Schlick-eysen and Heinen machines, and the capacity larger.

Anrep's machines of the above construction are, as has been previously stated, manufactured also by R. Dolberg, in Rostock, and by a number of Russian firms.

The elevator used is always an end elevator, about 35 feet in length. The lower end is carried up by two wheels resting on boards.

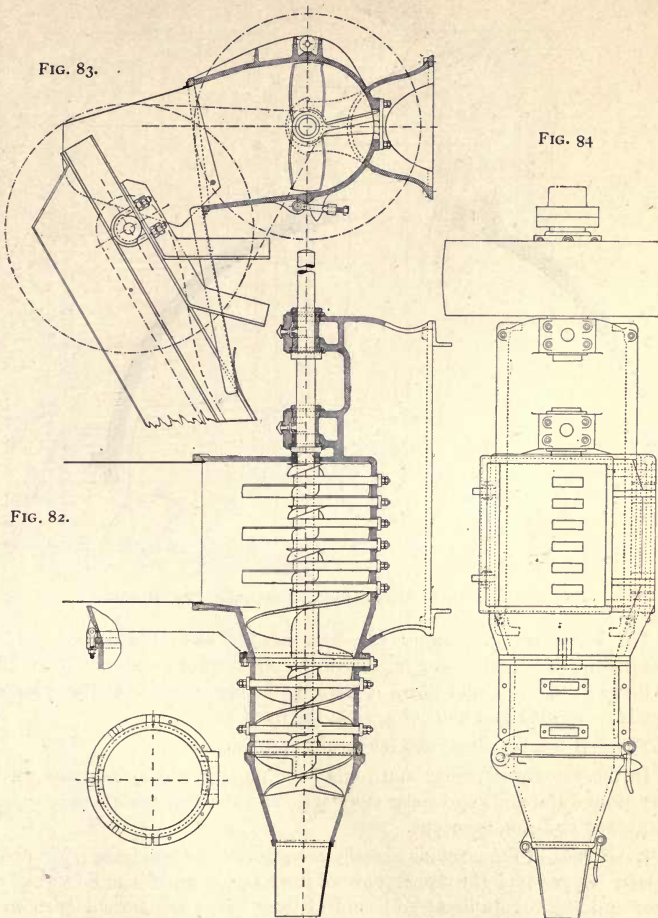
An Anrep peat plant of the construction usually employed in Russia is shown in Plate 19.

The later machines constructed by Anrep, which are displacing the older ones, have only one rotating shaft. These machines are at present manufactured in two sizes: No. I B and No. II B, by Abjörn Anderson, Svedala, Sweden.

*Machine No. 1 B.*—This machine as at present manufactured is shown in Figs. 82-84.

The feed hopper is made narrower at the top and widened out towards the machine in order to prevent the peat mass from forming an arch, which otherwise frequently occurs with one shaft machines.

The cylinder, in which the shaft rotates, is made with two different diameters connected by a conical part. In the wider part below the feed hopper the shaft is provided with six double knives of the construction shown in Fig. 85. These knives rotate against the six fixed knives inserted through the bottom of the cylinder and act as half bearings for the shaft. The fixed as well as the rotating knives, in this part of the machine, are each of the same pattern and of exceedingly strong construction. In the conical part of the cover the shaft is supplied with a screw thread which, with its two sharp edges, cuts against the fixed knives on either side. The narrower cylinder has three fixed knives inserted through the bottom and two through the top,



A. Anrep's Peat Machine No. I. B.

which latter with the two corresponding knives through the bottom form full bearings for the shaft.

The shaft is supplied in this part with two knives and a double screw thread, which, if desired, can be substituted by fixed and rotating knives, in case the peat requires a still more intensive pulping. In front of this cylinder is placed a conical part which carries the mouthpiece of the machine. The shaft in this conical part is provided with a double screw thread, which presses the peat mass towards the mouthpiece.

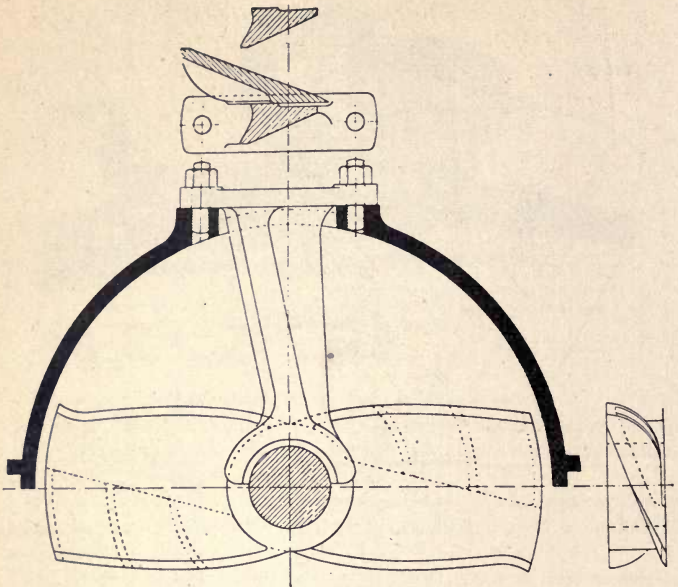


FIG. 85—Rotating and fixed knives in the Anrep Peat Machine.

The knives rotating under the feed hopper have bill-shaped points, on which the descending peat falls during their upward motion. These bills tear the peat to pieces and throw it towards the opposite side of the cylinder, where it is caught again and cut against the fixed knives.

The shaft makes about 260 revolutions per minute.

In these machines, fibres and roots have no opportunity to twist themselves around the shaft and cause stoppages, and the peat mass is exceedingly well pulped and homogeneous.

Every part of the machine is easily accessible. By loosening a few bolts, the feed hopper and the upper part of the larger cylinder can be turned on hinges and the mouthpiece and conical front piece are turned open in a similar manner.

The construction of the machine is simple and strong and permits of a large production.

The elevator and rolling table chiefly used are shown in Figs. 86 and 87. The former is a so-called drag elevator, without any special carrying arrangement at its lower end. It is made of channel beams and iron plates. The returning part of the chain with its pallets runs on a sheet iron bottom under the elevator, which permits the elevator to rest on the steps of the trench, and decreases the lifting of the raw material to a minimum.

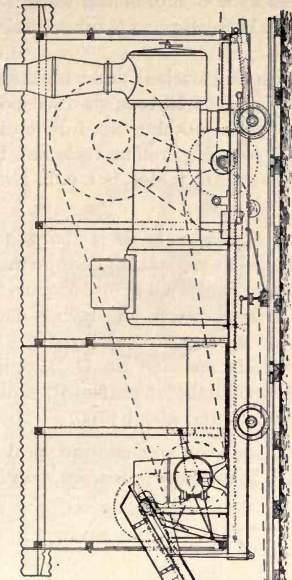


Fig. 86.

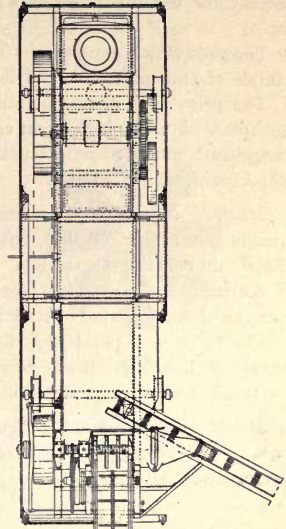
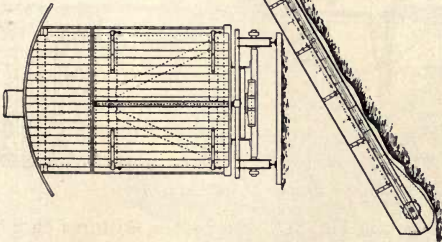


Fig. 87.



Peat Plant with Anrep-Svedala Peat Machine.

The rolling table is placed at an angle with the centre of the peat machine, whereby the cars generally used for the transportation of the machined peat are more conveniently loaded.

The rolling table is substituted by a belt conveyer when the new methods (see later) of transportation and laying out for drying are employed.

As a rule, these machines are operated by a 42 h.p. motor, which is also sufficient for the operation of a number of accessory apparatus, described later.

The production per day of 10 hours with this machine and with the usual methods of transportation and laying out is about 50 tons air-dried peat.

The price of a plant, including a complete machine No. 1 B, ordinary mouthpiece 5 x 5.2 inches, an elevator 33 feet long, rolling table and brake arrangement, mounted on a truck large enough for motor, is f. o. b. Svedala 4,400 kronor, about \$1,190.

*Machine No. II B.*—The construction of this machine is the same in principle as machine No. I B, but the dimensions are smaller and the number of fixed and rotating knives less. The production per day of 10 hours with this machine and the usual methods of transportation and laying out for drying is about 33 tons. A 34 h.p. motor is generally employed.

The price of a plant including a complete machine No. II B, ordinary mouthpiece 5 x 5.2 inches, rolling table and brake arrangement, mounted on a truck large enough for motor, is 2,800 kronor, about \$760.

*Machine Svedala No. 2.* The above firm also manufacture peat machines constructed by N. Fredriksson. These machines are numbered Svedala No. 2.

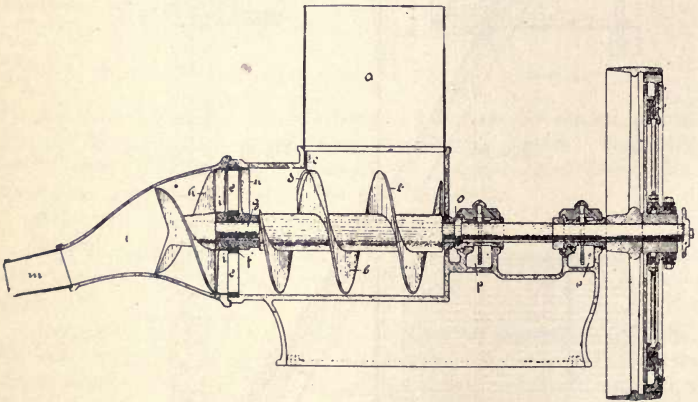


FIG. 88—Svedala Peat Machine No. 2.

The construction is shown in Fig. 88. The hopper (a) turns on hinges, whereby the interior of the cylinder is easily accessible. The conical front piece (l) carrying the mouthpiece (m) is also easily opened in the same manner. The machine has only one shaft, which is provided below the hopper and for some distance in the cylinder with a screw thread (b). This screw thread has a sharp edge (d) which cuts against an edge (c) fastened in the cylinder and 16 inches long. In front of the screw is a single knife (h) which



cuts against the sharp edges on the arms of the bearing (e) shown in Fig. 89. The peat mass is pressed forward between the arms of this bearing and on the other side is cut by the rotating knives (i), shown in Fig. 90. In front of this knife is a double threaded screw (k) which presses out the peat mass through the mouthpiece.



FIG. 89—Fixed Knife and Bearing (e).

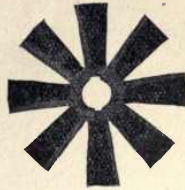


FIG. 90.—Rotating Knife (i).

The elevator and rolling table are of the same construction as those shown in Figs. 86 and 87. The machine is well constructed and suitable for well humified peat, but a certain part of the shaft has no tool for cutting or moving the peat, and fibres or roots have, therefore, an opportunity to cause stoppages, and so far as known, not many of these machines are in operation.

*Akerman's machines.*—These machines are manufactured by Akermans Gjuteri & Mekaniska Verkstad, Eslöf, Sweden, and have formerly been used to some extent in Sweden and Finland. The construction is shown in Figs. 91

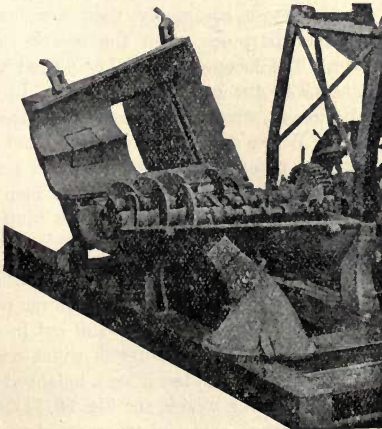


FIG. 91—Akerman's Peat Machine.

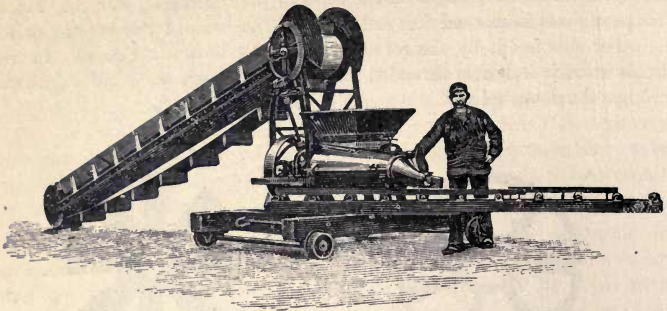


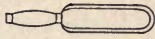
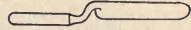
FIG. 92—Åkerman's Peat Machine.

and 92. The two rotating shafts are not parallel, but placed in a conical cover. They are provided with knives and screw threads, as shown in Fig. 91. The treatment of the peat in these machines is not much better than that in a Dolberg machine, and on account of their conical shape a number of differently constructed reserve parts require to be kept in stock. For fibrous peat and where roots are plentiful, they are not suitable.

A number of other peat machines have been used and are probably used at the present time in some localities, but they are either of less suitable construction or differ very slightly from those previously described.

**ARRANGEMENT OF PEAT MACHINE AND MOTOR.**—The peat machine and motor are, as a rule, placed on the same platform, which is movable on rails. The motors most commonly used are locomobiles, which can be employed for other purposes when the season for the manufacture of peat fuel is over. The locomobile is either placed with the fire-box facing the peat machine or in the opposite direction. In the former case the driving belt may be longer, which is favourable; in the latter case the firing is more convenient. Where electric power can be had cheaply, electric motors are used. For large plants, where a number of peat machines are working, electric motors are probably cheaper, as the men required to fire and attend to the locomobile can be avoided. The platforms are either moved forward by hand or by motor power.

**TRANSPORTATION AND LAYING OUT THE MACHINED PEAT FOR DRYING.**—The peat when it leaves the machine is taken up on pallets which are laid under the mouthpiece on the rolling table and cut in suitable lengths. For the cutting of the peat heavy knives, some of which are shown in Figs. 93–95, are usually employed. In some localities a balanced board provided with the required number of cutting blades, see Fig. 96, is used. The pallets with the peat bricks are loaded on cars and transported to the drying field. At small plants wheelbarrows, see Fig. 97, running on boards are used.

*Fig. 93.**Fig. 94.**Fig. 95.*

Knives for Cutting Peat.

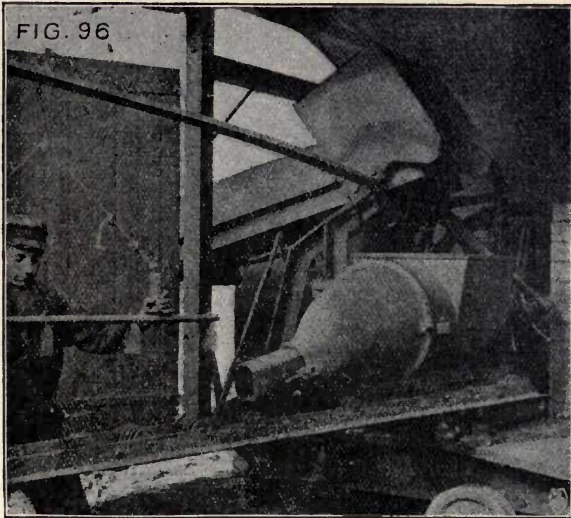


FIG. 96—Arrangement for Cutting Peat.

The arrangements of such a plant in a drained bog with a Dolberg one-horse peat machine are shown in Fig. 98. In undrained bogs a cutting machine (described on page 29) is used for the cutting and lifting up of the raw peat,

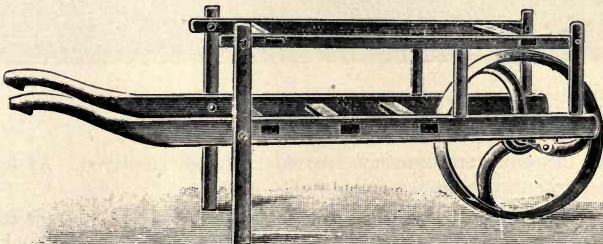


FIG. 97

FIG. 97—Wheelbarrow for transport of Peat Pallets to drying field.

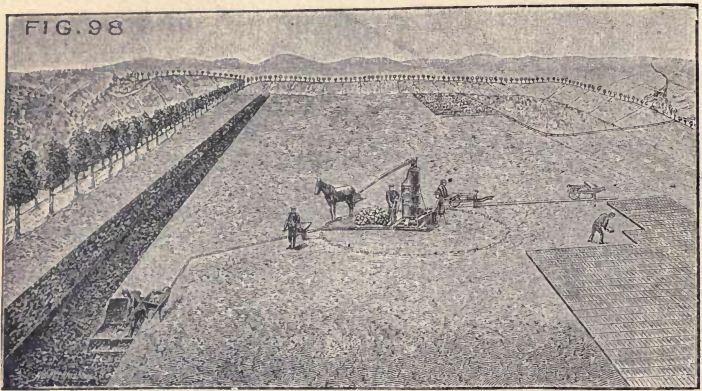


FIG. 98—General arrangement at a Dolberg Peat Plant with a one horse Peat Machine (in a drained bog).

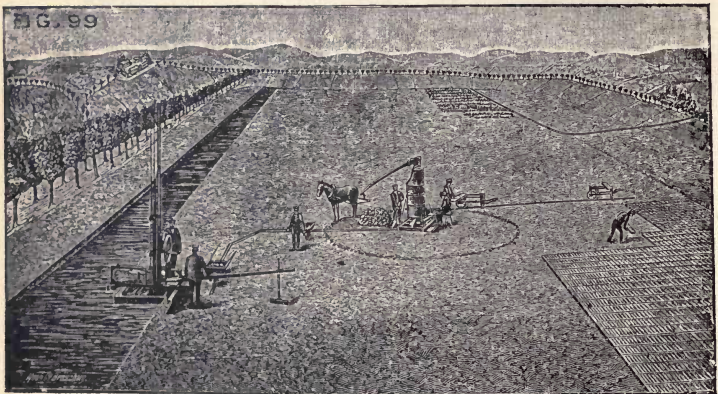


FIG. 99—General arrangements at a Dolberg Peat Plant with a one horse Peat Machine (in a wet bog).

otherwise the same arrangements, see Fig. 99, are employed. At larger plants cars running on tracks are generally used.

These cars are either made of iron or wood and constructed for three, two or one row of peat pallets. The weight of the loaded cars should not be too great to be easily moved by one man. The cars chiefly used are shown in Figs. 100–103. Those with two or one row are more conveniently loaded and unloaded and better liked by the workmen.

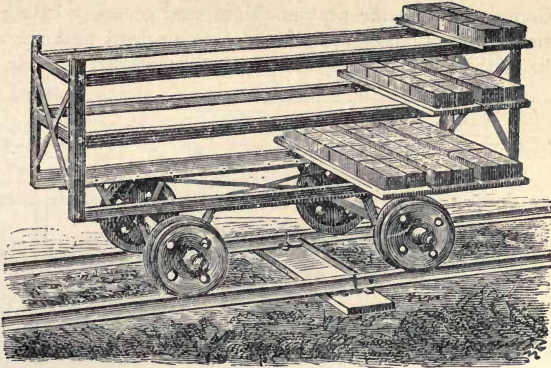


FIG. 100—R. Dolberg's car for transport of Peat Pallets.

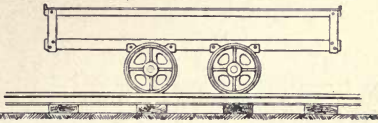


FIG. 101—Sugg & Co. car for transport of Peat Pallets..

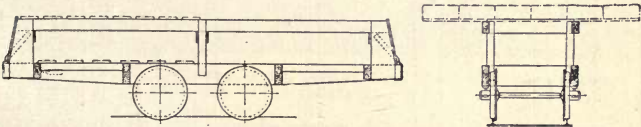


FIG. 102—Anrep's car for transport of Peat Pallets with Peat Machine No. I. B.

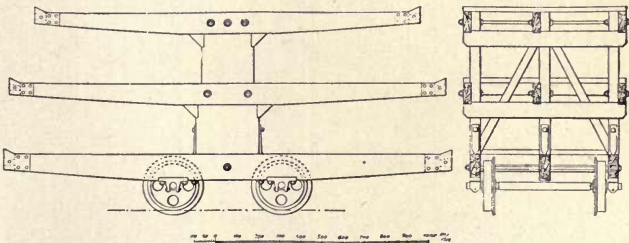


FIG. 103—Anrep's car for transport of Peat Pallets with Peat Machine No. II. B.

The methods used for the transportation of the loaded cars to the drying field and the transportation of the empty cars back to the peat machine are numerous, but the following are those principally employed:

In Germany, where the peat machines used generally have a comparatively small production, or some 20–25 tons air-dried peat per day of 10 hours, the method shown in Fig. 104 is often employed. In this case only

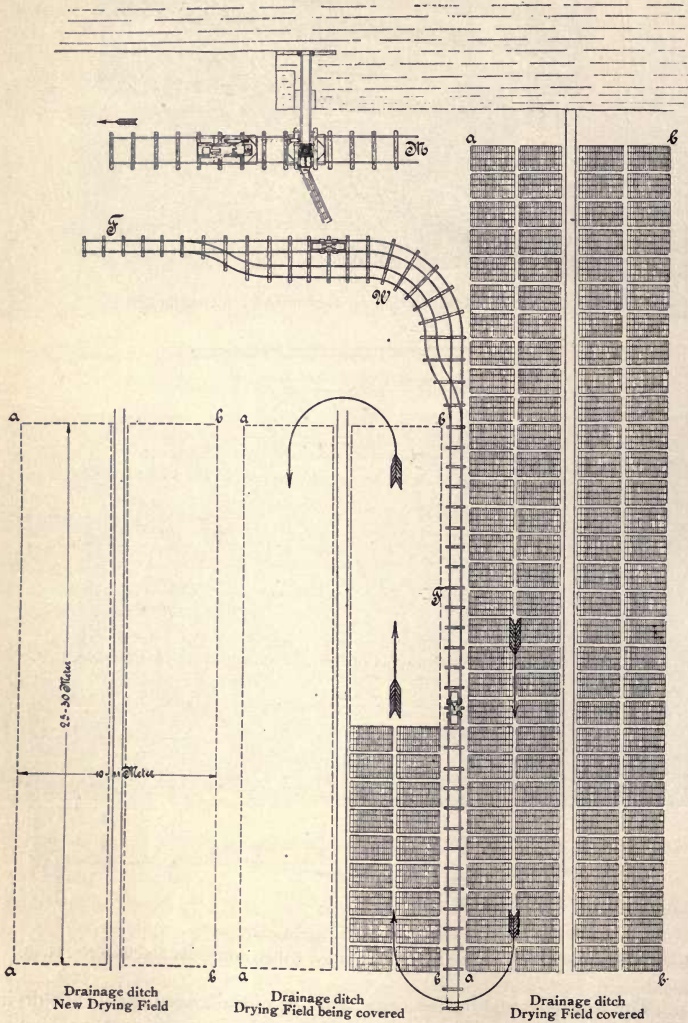


FIG. 104—Method of transportation to and from drying field and arrangements on the bog, employed in Germany.

one portable track with a short siding is used. The loaded car is brought to the drying field, unloaded and brought back on the siding before the next car has reached the single track on the drying field. As soon as the area which can be conveniently reached from one position of the track is covered, the track is moved to its next position, as shown in the fig. This method allows only a very limited number of cars to be continuously used and is, therefore, less suitable for a large production.

The method usually employed in Germany is shown in Figs. 105–107.

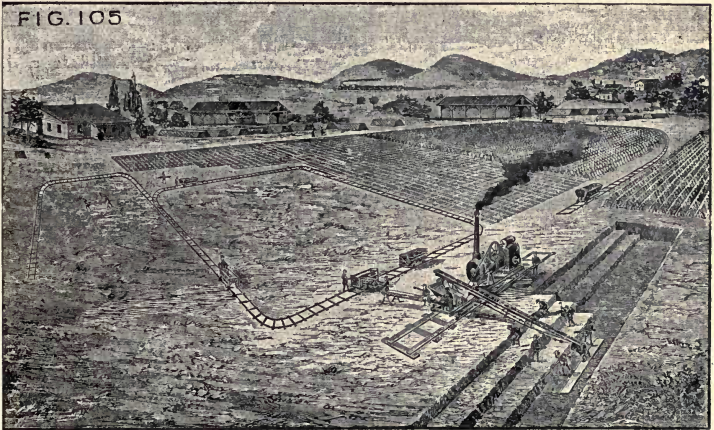


FIG. 105—General arrangements at a Dolberg Peat Plant with Peat Machine No. I. b. or I. c. (in a drained bog).

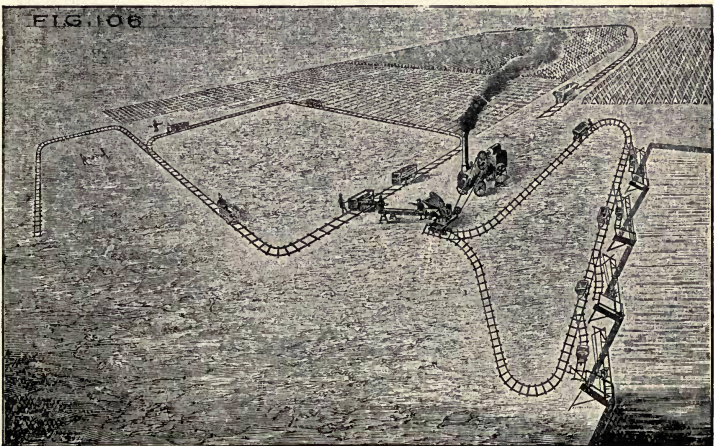


FIG. 106—General arrangements at a Dolberg Peat Plant with Peat Machine No. I. b. and Cutting Machines (in a wet bog).

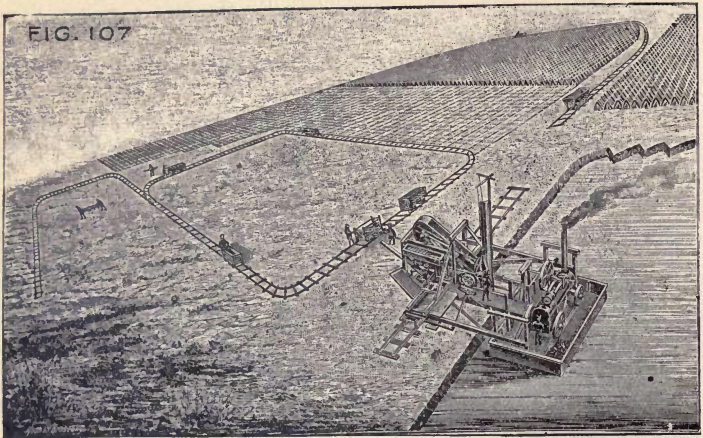


FIG. 107—General arrangements at a Dolberg Peat Plant with Peat Machine No. 1. b. and Cutting Machine for Motor-power.

The portable track is laid down as a rectangle with round corners, so-called round track, which permits the cars to be moved continuously in one direction. By this method any desired number of cars can be employed, but the distance which each car has to travel is considerably increased and necessitates the employment of more men than otherwise would be required for the same production.

Fig. 105 shows the general arrangement at a Dolberg plant, with a peat machine No. 1 b or 1 c, in a drained bog. Fig. 106 is the same in an undrained bog, where cutting machines for hand power are used, and Fig. 107 the same in an undrained bog where cutting machines for motor power are used. The track is made in sections of suitable lengths, and when the area of the drying field has been covered from a certain position of the tracks at two sides of the rectangle, these two sides are moved and shortened the required length and the laying out continued.

The laying out with round tracks is also done as shown in Figs. 108 and 109.

In Russia, Sweden, etc., the method with parallel tracks, shown in Fig. 110, is chiefly employed. By this method the distance which the empty cars have to travel is decreased to a minimum. The peat bricks are first laid out at the greatest distance from the working trench, and as soon as the drying field in front of one section of the track is covered, this section is removed the distance, *d*. When the whole width of the drying field is covered from the track A, the curves C, D and E are moved to their new positions, and the peat now brought out on the former returning track B. Instead of the curves D, the use of which requires that the track should always be moved



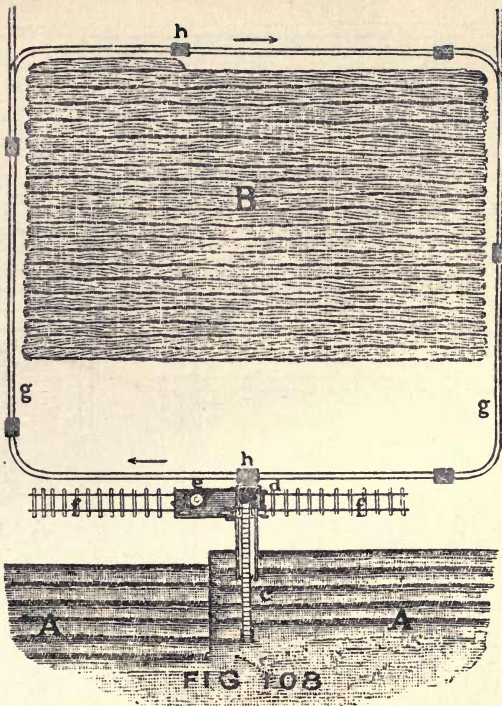


FIG. 108—Transportation and laying out for drying with round track  
(B. peat bricks laid out)

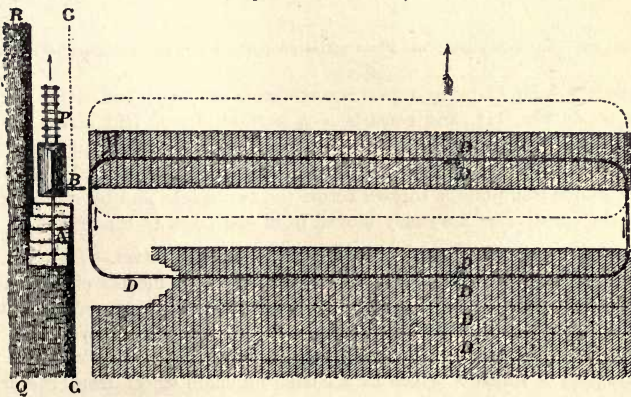


FIG. 109—Transportation and laying out for drying with round track  
(D. peat bricks laid out)

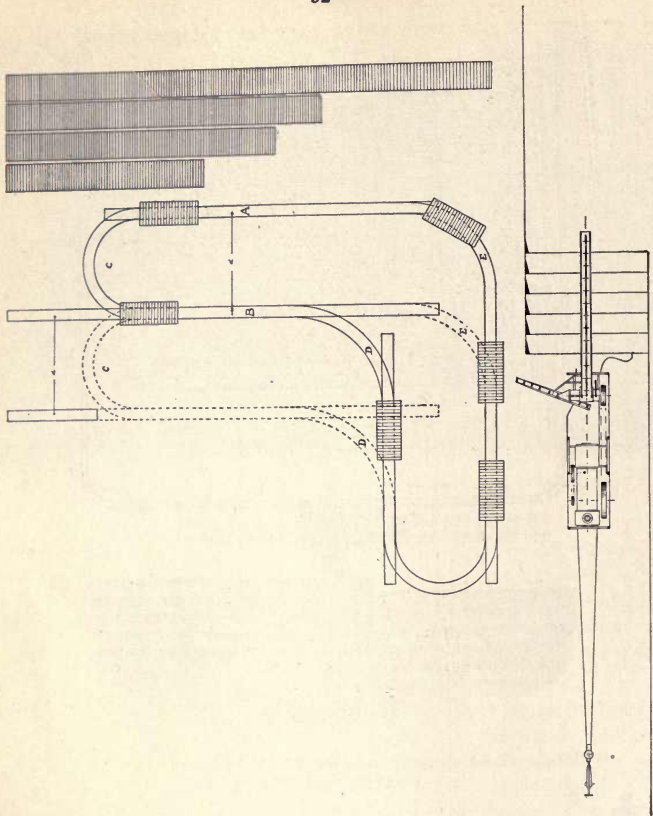


FIG. 110—Anrep Svedala Peat Plant with transportation by hand on parallel tracks.

exactly the same distance, other arrangements are employed. One of these is shown in Fig. 111, and consists of a portable frame laid across the two tracks. This frame carries a low truck with rails for the empty peat cars, which are pushed up on these rails and moved to the other track. Occasionally a simple iron plate is thrown across the two tracks and by means of this plate the empty cars are easily moved from one track to the other.

*Anrep's round track with mechanical transportation.*—The peat cars are by this method (see Fig. 112) transported by means of an endless cable driven by the same motor as the peat machine. The number of men otherwise required for this transportation is hereby avoided.

The platform of the peat machine and motor is provided with two rope pulleys, one of which is driven by a chain and chain wheel from the motor

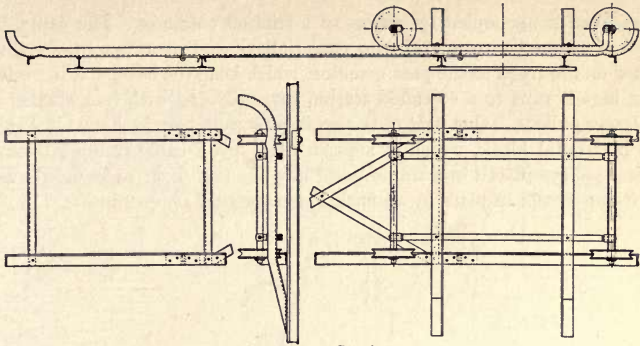


FIG. 111—Carrier.

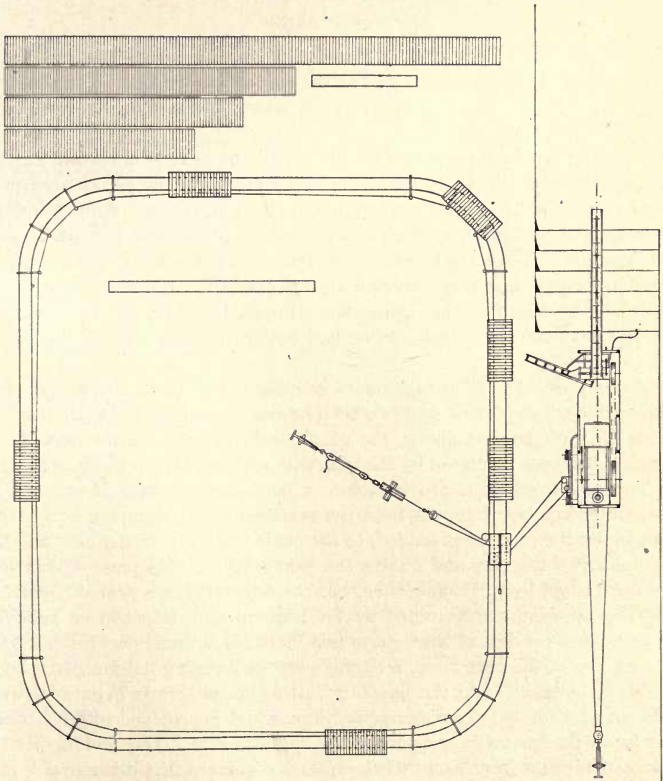


FIG. 112—Anrep Svedala Peat Plant with cable transportation on round track.

and coupled or uncoupled by means of a friction coupling. The cable, 0.36 inches in diameter, runs over two rope pulleys and over two other pulleys, located on the truck to the peat machine, which keep the two parts in position. From here it runs to a so-called station car, provided with four smaller and two larger pulleys. One part of the cable runs from here as shown in Fig. 112 to a horizontal block, which is kept in place by a cable running over two vertical pulleys placed in a frame (see Plate 23) and kept tight by a weight. The frame is kept in place by an anchor arrangement, shown in Fig. 113. The

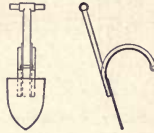


FIG. 113—Anchor

cable runs from the block back to the station car, around a larger pulley and around the track, which is provided at the curves with rollers. The peat cars are provided with a coupling apparatus of wood, operated by a lever, and are easily coupled or uncoupled.

Double tracks are used on the side where the peat is unloaded, so that when the whole width of the drying field is covered only the curves need to be moved at once and the work can continue with a minimum of interruptions. The stretching apparatus must also be moved simultaneously in order to keep the cable tight. When the lengths of the two sides of the track in the direction in which the peat machine is moved are too small, the whole track is moved forward. The width of the drying field should, however, be such that the peat dug out from the trench can be laid out the same length on the drying field.

*Anrep's mechanical transportation combined with C. W. Jakobson's field press.*—In order to further decrease the number of men required and increase the capacity of the peat plants, the usual method of placing the peat bricks on pallets has been displaced by the following method, shown in Fig. 114.

The peat machine is provided with a belt conveyer instead of a rolling table, which conveys the peat from the machine to the dumping cars. One man couples the cars, when loaded, to the cable. On the drying field another man uncouples the cars and dumps the peat into the field press. This field press is invented by C. W. Jakobson, but the original idea is probably derived from the apparatus constructed by Th. Ekholm and described on page 54. The field press consists of three parts (see Plate 24), a front part intended for the reception of the peat mass, a middle part for levelling the mass to a layer of uniform thickness, and a third part for cutting this peat layer in parallel rows. The front part consists of a rectangular frame, which is provided with a wooden roller below the front side and open at the opposite side. The middle part is connected with the front part by bolts in such a manner that it is movable in a vertical direction. It is covered by a slightly inclined cover, with the higher

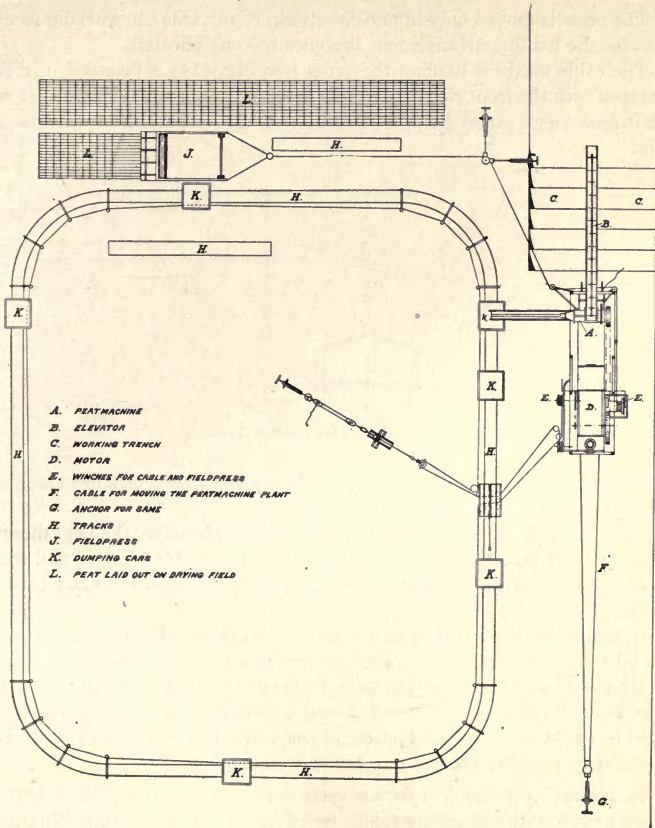


FIG. 114—Anrep Svedala Peat Plant with cable transportation on round track and fieldpress.

side in front. The back part is also connected with the middle part in such a manner that it is movable in a vertical direction and covered in the same manner. Below this cover 14 vertical plates, 5 inches in height, are placed, which cut the peat mass to this depth. When the press is hauled forward, these knives cut through the peat mass and by means of wooden knives placed behind and pressed down by springs the mass is divided into 15 continuous rows. The covers to the back and middle parts are pressed down by weights, as required.

The peat rows laid out by the press are cut in suitable lengths by the tool shown in Fig. 115.

The press is moved only in one direction, i.e., towards the working trench, otherwise the hauling arrangement becomes too complicated.

The cable used for hauling the press (see Fig. 114) is fastened in a ring connected with the front side of the press by two ropes of equal lengths. From there it runs over a pulley held in place by two anchors, and to a winch at the motor.

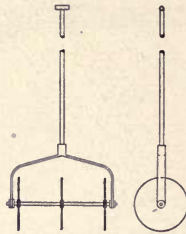


FIG. 115—Tool for Cutting Peat.

When the end of the line is reached, the press is loaded on a low truck and brought back to the beginning of the next line.

One man is generally employed at the press for levelling the peat dumped into it, another man for cutting the peat rows in suitable lengths, and a boy stationed at the plant for signaling to the engineer in case the press requires to be stopped.

A similar arrangement is also employed when parallel tracks instead of a round track is used. The arrangement in this case is shown in Fig. 116.

By this method the peat bricks laid out on the drying field obtain a better shape and the dirty work of loading and unloading the pallets usually employed is avoided. The production is considerably increased and the cost lowered on account of the less number of men employed.

*A. Körner's arrangement for transport to the drying field.*—This apparatus consists of a number of rolling tables (see Figs. 117–119 and Plate 25) placed on wooden supports. One side of the table has rollers turning in one direction, and the other side has the same turning in the opposite direction. A number of such tables are placed in front of each other until the further side of the drying field is reached. Each section is about 20 feet long and is easily moved.

The rollers for each section are turned in their respective directions by means of a chain running on the top and underneath every second roller, as shown in Fig. 117. The chain is driven by a pulley, which derives its motion from a bevel gear operated by the shaft placed underneath. This shaft is driven direct from the peat machine and is supplied with special couplings for each section. These couplings are constructed in such a manner that the different sections of the shaft have about 3 inches play in a longitudinal direction and also permit the different sections to make certain angles with each other.

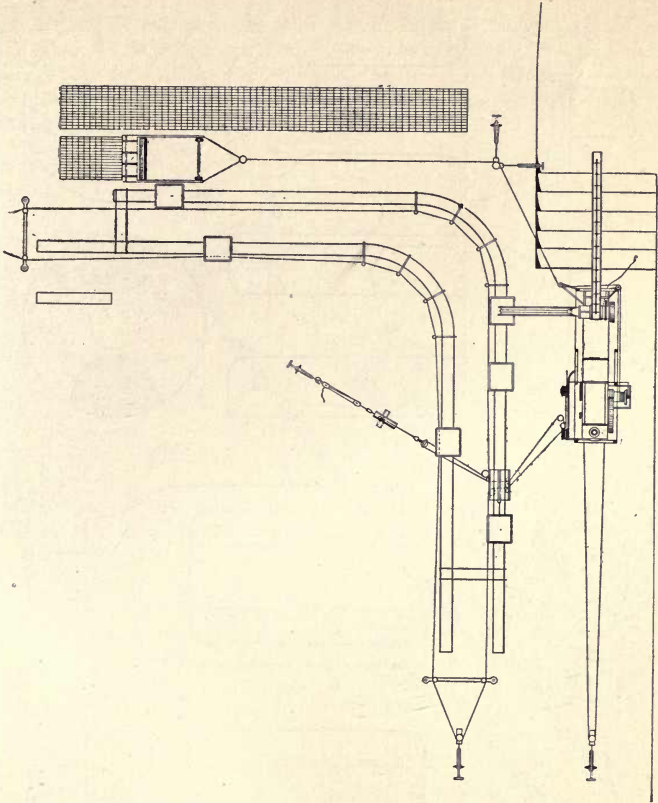


FIG. 116—Anrep Svedala Peat Plant with cable transportation on parallel tracks and field press.

Fig. 117.

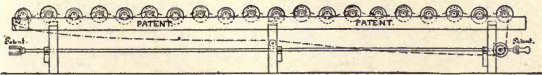
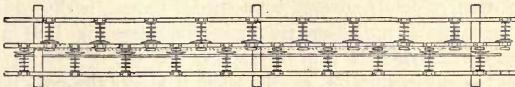


Fig. 118.



Fig. 119.



• A. Körner's Peat Pallet Conveyor.

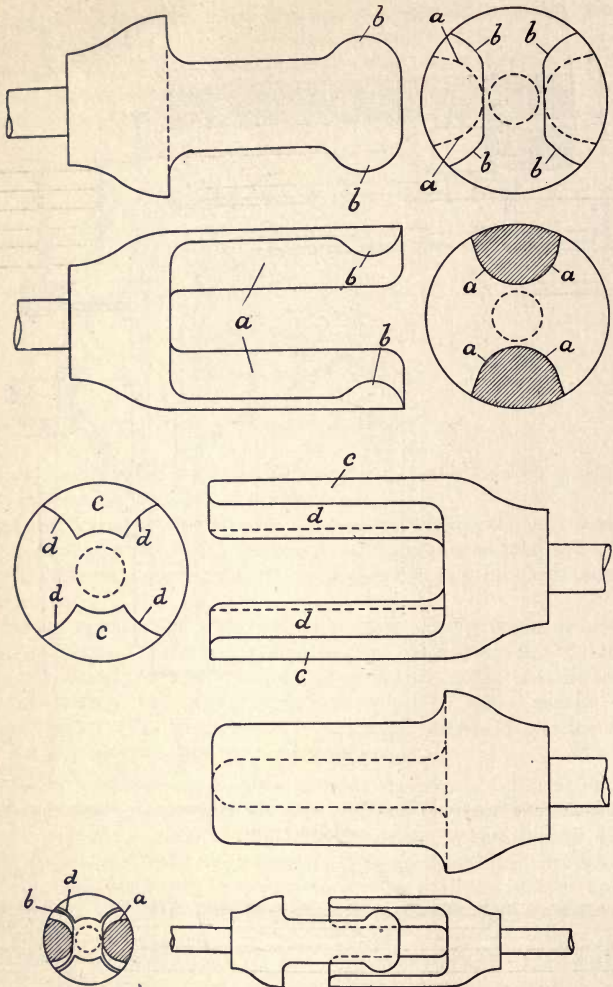


FIG. 120—Coupling to A. Körner's Peat Conveyor.

The construction, which is covered by a special patent, is shown in Fig. 120. The rollers on the table are placed a little inclined (see Fig. 118) in order that the usual pallets carrying the peat bricks may stay on.

The peat is cut in suitable lengths when it leaves the peat machine and transported by the rollers on one side of the table to the drying field. The



empty pallets are placed on the other side of the table and transported back to the plant. The pallets can naturally be taken off at any desired point, as shown in Fig. 121. When the drying field furthest from the plant is covered, the sections covering this distance are uncoupled and moved to the next line, as shown in the figure.

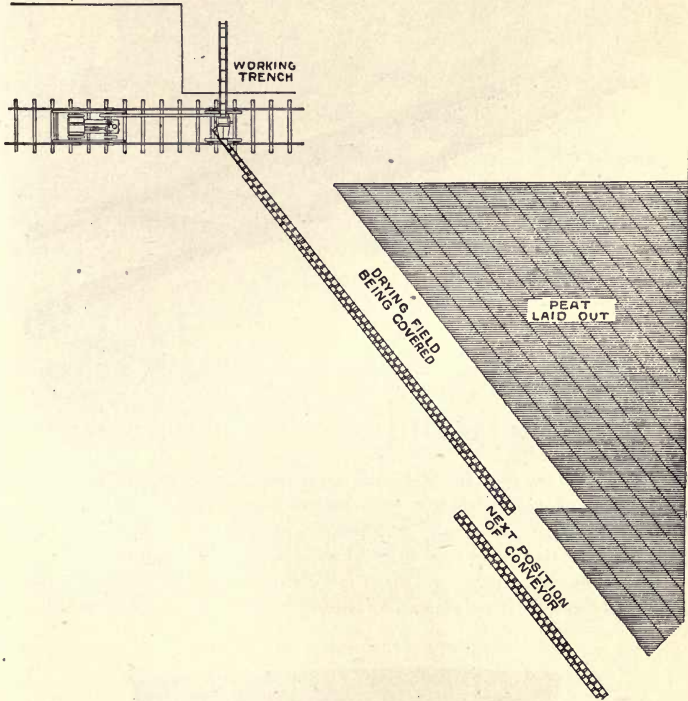


FIG. 121—A. Körner's Peat Conveyor and Method of laying out for drying.

This arrangement can be used even where the surface of the bog is fairly uneven and by its employment tracks and men required for transportation are avoided. The objection to its employment is that it consists of a great number of parts, which are liable to break and cause stoppages and repairs.

The apparatus is manufactured by A. Körner, Eslöf, Sweden, and costs 32 kronor per meter, about \$2.65 per foot, f.o.b. Eslöf.

#### DRYING AND STORING.

The peat bricks laid out on the drying field are turned and piled in heaps in a manner similar to those already described. If the peat is sold as soon as

it is dry, no stacking or storing is necessary, but if this is not the case stacking or storing is required.

A permanent track some distance from the working trench is generally laid down and from this permanent track portable tracks are used to reach the drying field. The tracks used in this work, as well as for most other purposes, are made of light rails bolted or riveted in sections to steel ties, see Fig. 122.

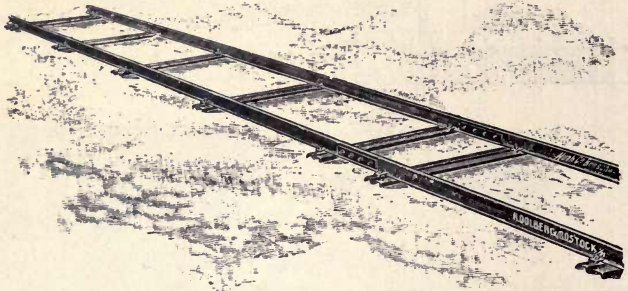


FIG. 122—Portable Tracks used on Peat Bogs.

The cars chiefly employed for transportation of the dry peat are shown in Figs. 123-127.

In some cases special sheds are used for storing the dry peat. These sheds are made with triangular sections and with a rather small angle at the top, in order that no snow may remain on the roof. By this construction only light lumber is required and the cost thereby decreased.

At some of the larger plants a large storehouse with loading facilities is generally erected at the nearest railway station.

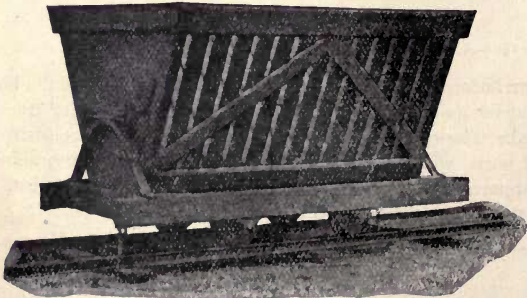


FIG. 123—Car for transport of dried Peat.

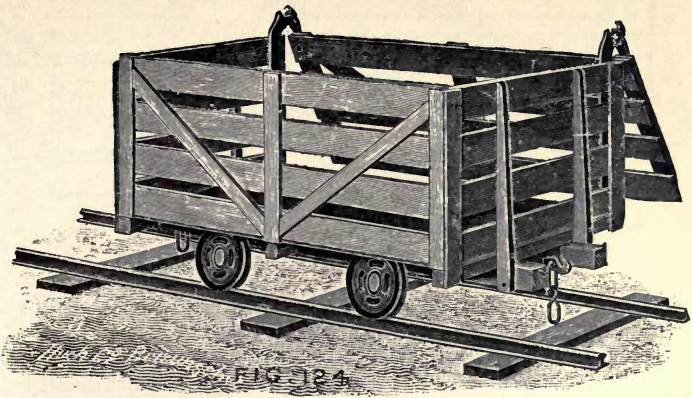


FIG. 124—Car for transport of dried Peat.

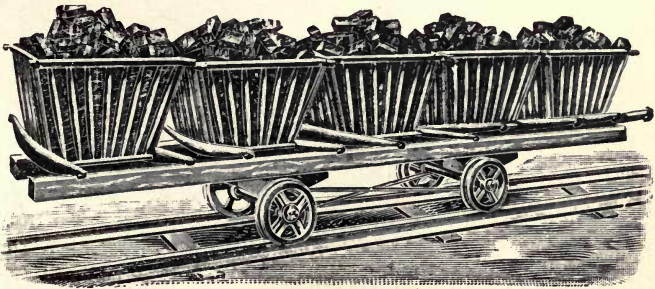


FIG. 125—Car for transport of dried Peat.

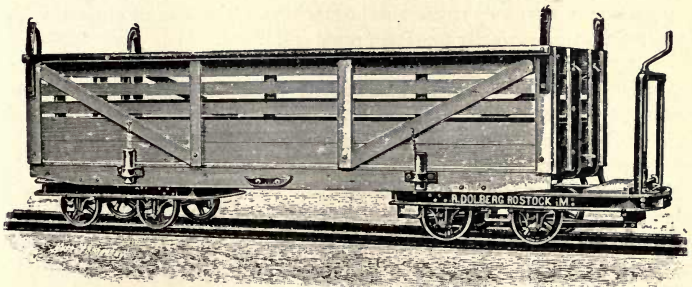


FIG. 126—Car for transport of dried Peat.

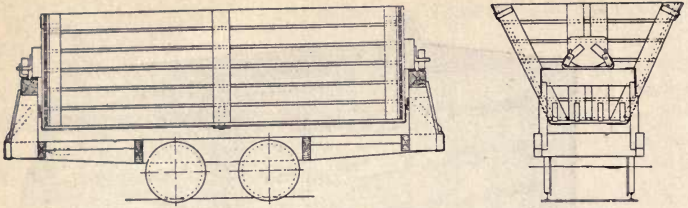


FIG. 127—Car for transport of dried Peat.

## DESCRIPTION OF INDIVIDUAL PEAT PLANTS.

*Stafsjö.*—The commission, appointed by the Swedish Government to test different peat machines, made in 1903 tests at the above place with Anrep's machines Nos. I B and II B, and with Svedala No. 2.

The tests lasted during two days, 10 hours a day, and later special tests were made in order to ascertain the maximum capacity of the plants and the suitability of the peat machines for treatment of fibrous peat plentifully mixed with tough roots. The raw peat contained on an average 11.6% dry peat substance, and the machined peat 12%.

The peat bricks were loaded on pallets and transported and laid out on the drying field by hand on parallel tracks, as described on page 90.

*Tests with Anrep Machine No. I B.\**—The construction of the machine is given on page 78.

The number of men employed was as follows: 1 engineer, 1 helper, 10 diggers, 2 loading the peat pallets on the cars, 6 transporting the cars to drying field, 4 unloading and laying out the peat for drying, and 3 boys attending to the pallets and cutting the peat—total, 24 men and 3 boys.

During 20 hours 794 cubic yards of raw peat were dug out from a trench 19.8 feet wide and 7.3 feet deep. The locomobile used was of 42 h.p. and was supplied with winch and cable for stump pulling. During the trial 69 stumps were pulled up without any interruption in the work. No choking occurred in the hopper to the peat machine and all the material brought up by the elevator was easily treated in the machine. The interior of the machine was after the trial perfectly free from roots and fibres.

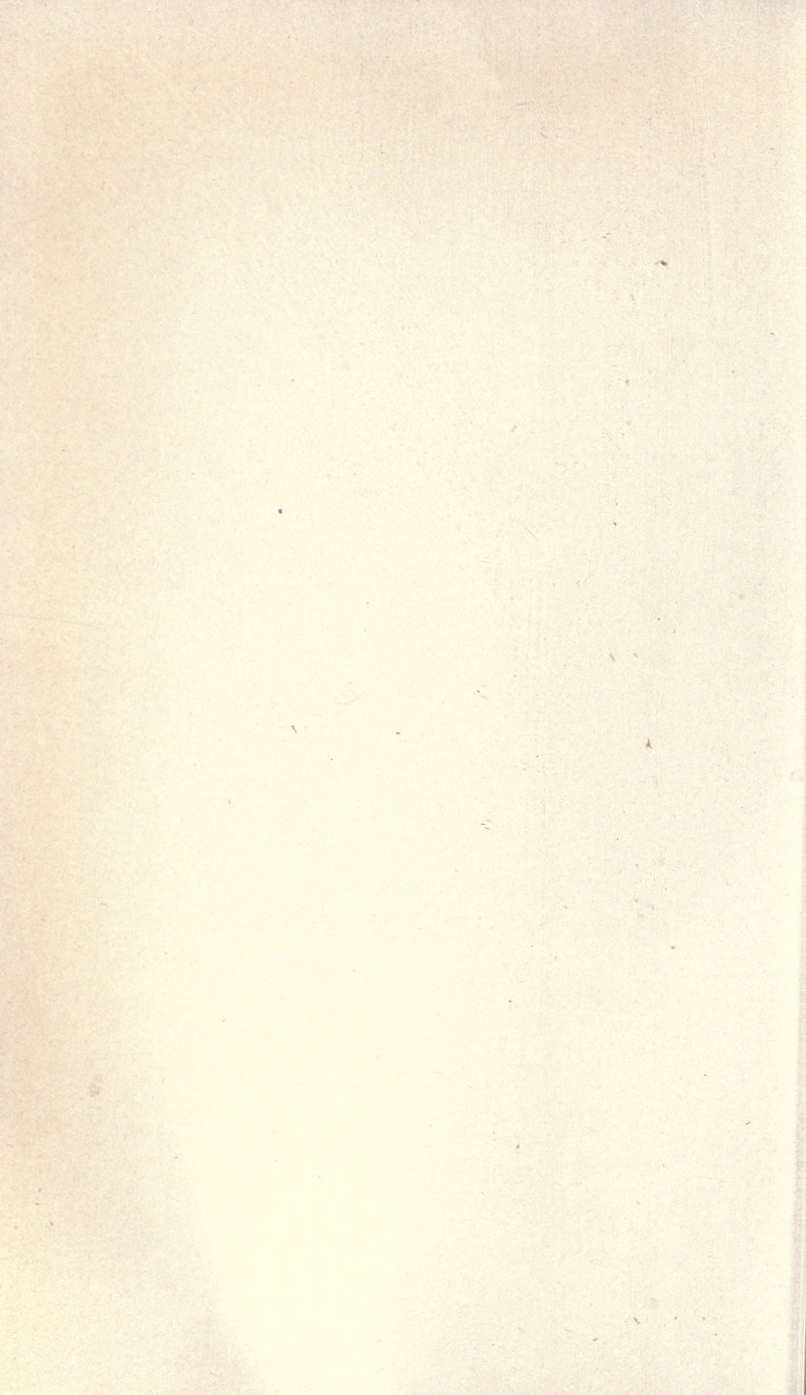
The peat was cut on the rolling table into pieces 12 inches in length, and the pallets were 6 feet long. The interior dimensions of the mouthpiece were 4.84 x 5.36 inches = 25.94 sq. inches. Each peat brick contained, therefore, 311.3 cubic inches of wet peat and each pallet 6 x 311.3 = 1,867.8 cubic inches. The cars used (see Fig. 102) for transportation to the drying field were each loaded with about 30 peat pallets. The peat bricks were unloaded on a 20 feet wide strip of the drying field on the further side of the exterior track and when the strip was covered this track was moved 20 feet back from the interior track. The carrier shown in Fig. 111 was used for the

\* Anrep's machines were at that time manufactured by Munktell, Eskilstuna, Sweden.

PLATE 20.



Anrep Peat Machine No. II. B. at Stafsjö, Sweden.



transportation of the cars from one track to the other. During the trial the tracks were moved 6 times, the time required for each moving being 5<sup>5</sup> minutes.

The first day 53,220 peat bricks from 8,870 pallets were laid out on the drying field and during the second day 51,780 from 8,630 pallets, total 105,000 peat bricks during 20 hours, or 639.03 cubic yards. The area covered on the drying field was 6391.4 square yards, or 10 cubic yards per 100 square yards.

The raw peat treated per man and day (10 hours) was 15.55 cubic yards. 794 cubic yards of raw peat\* produced 639 cubic yards of machine peat, the reduction in volume through the mechanical treatment was, therefore, 19.5%.

The raw peat contained 11.6% dry peat substance and had a specific weight of 1.0. Calculating on air-dried peat with 25% moisture, the production per day was 51.59 tons.

During the special tests made, the production during half an hour amounted to 29.39 cubic yards of machine peat or 587.8 cubic yards per day of 10 hours, which would equal 94 tons air-dried peat with 25% moisture. It is naturally not possible to obtain such a production during a continuous working, but it clearly demonstrates the large capacity of this machine.

The test made with fibrous peat and tough spruce roots showed that the machine was fully able to treat such material.

*Tests with Anrep Machine No. II B.*—The arrangements at this plant are shown in Plate 20.

The number of men was as follows:—1 engineer, 1 helper, 6 diggers, 1 loading the peat pallets on cars, 5 transporting the cars to the drying field, 2 unloading and laying out the peat for drying and 3 boys attending to the pallets and cutting the peat.

The machine used was of older construction and not provided with the later improvements. A 25 h.p. locomobile furnished the power.

During 20 hours 528.34 cubic yards of raw peat were treated. The interior dimensions of the mouthpiece were 4.92 x 5.36 inches.=26.37 square inches.

Each peat pallet was 52.8 inches in length and the peat was cut in lengths of 13.2 inches. The cars used for transportation (see Fig. 103) were each loaded with about 25 peat pallets.

During the trial 67,220 peat bricks=452.5 cubic yards, were laid out for drying. The raw peat treated per man and day (10 hours) was 15.04 cubic yards. The reduction in volume through the mechanical treatment was 14.35% and the daily production 34.37 tons air-dried peat, with 25% moisture.

During the special test made, the production during half an hour amounted to 14.8 cubic yards of machine peat or 296 cubic yards per day of 10 hours. This machine also treated fibrous peat and roots to satisfaction.

\* Including the volume occupied by the tree stumps.

*Tests with Svedala No. 2.*—This machine was driven by a 25 h.p. electric motor, but in order to compare the results obtained the number of men employed is assumed to be that required if a locomobile was used. In such a case the number of men employed would have been:—1 engineer, 1 helper, 8 diggers, 1 loading the peat pallets on cars, 6 transporting the cars to the drying field, 3 unloading and laying out the peat for drying and 3 boys attending to the pallets and cutting the peat.

The construction of the machine is described on page 82.

During the trial 505.8 cubic yards of raw peat were treated in the machine.

The interior dimensions of the mouthpiece were 5.2 x 4.98 inches = 25.89 square inches. Each peat pallet was 54 inches in length and the peat was cut by the knife shown in Fig. 96.

During 20 hours 78,220 peat bricks from 15,644 peat pallets were laid out for drying. The volume of the machined peat was 437.92 cubic yards.

The raw peat treated per man and day (10 hours) was 11.75 cubic yards. The reduction in volume through the mechanical treatment was 13.4%, and the daily production 32.9 tons air-dried peat with 25% moisture.

During the special test made, the production for half an hour amounted to 22.15 cubic yards of machined peat or 443 cubic yards per day of 10 hours.

This machine occasionally required cleaning, and after the test with the fibrous material were found roots and fibres twisted around certain parts of the machine, otherwise it was satisfactory.

*Koskivara, Sweden.*—In order to ascertain the possibilities of manufacturing peat fuel in the northern part of Sweden, the Swedish government erected an experimental plant at Koskivara, situated at 66° 39' latitude.\*

---

\* Report by the Swedish Department of Agriculture.



The season during which air-dried peat fuel can be manufactured here is very short, as shown in the following table:—

YEAR 1905.

	JUNE		JULY		AUGUST		June 16- Aug. 31	
	16-30		1-15		16-31		Aug. 15	
	2-15	16-30	1-15	16-31	1-15	16-31	Aug. 15	Aug. 31
Temperature degrees Centigrade	+ 12.1 27.0 2.0	+ 14.8 25.0 4.0	+ 11.8 26.0 3.0	+ 15.5 27.0 5.0	+ 12.1 21.0 5.0	+ 9.3 18.0 0.0	+ 13.5 27.0 3.0	+ 12.6 27.0 0.0
Barometer m/m Hg	732.7 742 721	734.0 741 727	726.9 735 717	728.7 737 721	728.7 736 721	732.6 740 716	729.5 741 717	730.6 742 716
Clouds (scale 0-10).....	3.5	3.7	7.0	5.7	6.5	4.9	5.7	5.2
Rain { Total in Number of days $\geq$ 0.1 Number of days $\geq$ 1.0	6.3 3 1	5.3 3 2	27.2 3 6	85.9 9 8	81.3 10 8	8.0 6 2	199.7 30 24	214.0 39 27
Clear sky, number of days.....	7	5	1	4	0	3	10	20
Half clear sky, number of days.....	4	9	6	6	10	10	31	45
Cloudy sky, number of days.....	3	1	8	6	5	3	20	26
Velocity of wind (scale 0-6).....	1.4	2.2	2.8	1.8	2.0	1.7	2.2	2.0

These figures are a little less favourable than under normal conditions, but the peat manufactured had sufficient time to dry.

The arrangements on the bog are shown in Fig. 128. This plant was in operation during 1903-1905.

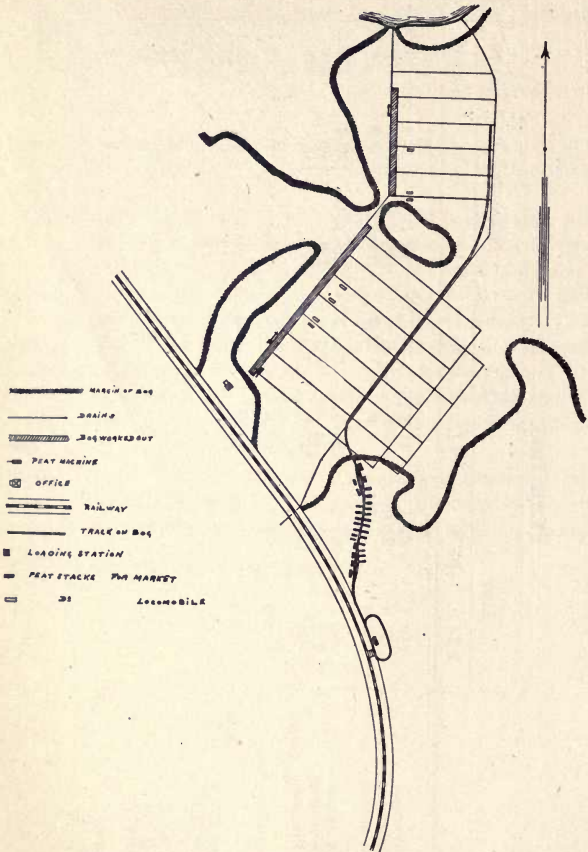


FIG. 128—Peat Bog at Koskivara, Sweden.

The peat machine used was an Anrep machine No. II. B, driven by a 23 h.p. locomobile.

The transportation and laying out of the peat bricks were done in the usual way, with the peat pallets loaded on cars run on a parallel track.

During 1904 the plant was in operation from June 6 to July 5 and the results obtained are given in the following table:—

	THE UPPER BOG.		THE LOWER BOG.	
	June 6-11. 6 working days men paid by day.	June 13-28. 12 working days contract work.	June 30-July 5. 4 working days contract work.	June 6-July 5. 22 working days.
	Average number of men (including engineer, helper, and one man for removing the surface layer; 2 boys=1 man.)	15	16½	13½
Raw peat dug out, cub. yards	682.6	2176.1	631.6	3490.4
Machined peat, cub. yards	622.5	1987.8	544.0	3154.3
Difference in volume of raw peat and machined peat, cub. yards.	60.1	188.3	87.6	336.1
Reduction in volume, %	8.8	8.7	13.9	9.6
Manufactured and on the drying field laid out wet machine peat (a 234 cub. inches), pieces.	130400	416600	114000	661000
do. do., per 10 hours, on an average, pieces.	21733	34717	28500	130045
Area of drying field covered, acres	.....	.....	.....	8.15
Machine peat laid out per acre, cub. yards.	.....	.....	.....	387
Machine peat laid out per acre, pieces	.....	.....	.....	200303
Machine peat laid out per acre, calculated on air-dried peat (a 1.87 lbs. per piece), tons.	.....	.....	.....	187
Manufactured peat (air-dried), tons.	121	496	617	.....
Labour cost, dollars.	86.50	270.54	357.04	.....
Labour cost, per ton, digging, laying out, dollars	0.71	0.54	0.58	.....
Each man made per day, dollars.	0.96	1.10	1.05	.....
Engineer made per day, dollars	1.10	1.10	1.10	.....

The drying work per ton air-dried peat costs 3.46 cents for turning the peat bricks, 8.82 cents for piling in heaps and for transport, stacking or storing 25 cents, total: 37.38 cents. The total cost per ton, including all expenses, amounted to about \$1.50.

Considering that the plant only had a small production, this figure shows that peat-fuel, even where the season is so short and drying conditions less favourable, can be manufactured on an economical basis.

*St. Olof, Sweden.*—The peat plant at the above place is one of the most modern plants in operation in Europe.

The area of the bog is about 155 acres and the depth 12-15 feet. The peat is of a good quality and contains very little ash, as seen by the following analysis made at the laboratory of the Swedish Peat Society.

Peat fuel from St. Olof:

Moisture . . . . .	24.61%
Ash . . . . .	1.20%
Organic substance . . . . .	74.19%

Calorific value in bomb calorimeter:

Dried sample . . . . .	8,917 B.T.U.
Dried and ash-free sample. . . . .	9,061 "
Original sample . . . . .	6,046 "

The bog is partly drained by ditches and otherwise kept sufficiently dry by a waterscrew, which works very satisfactorily. It is worked with two peat machines, one on each side of the working trench. The drying field is drained by covered ditches in order that the surface may be unbroken. These ditches are dug in the manner shown in fig 129. The large surface sods are first cut out and again put back when a drain about 6 inches square has been dug.



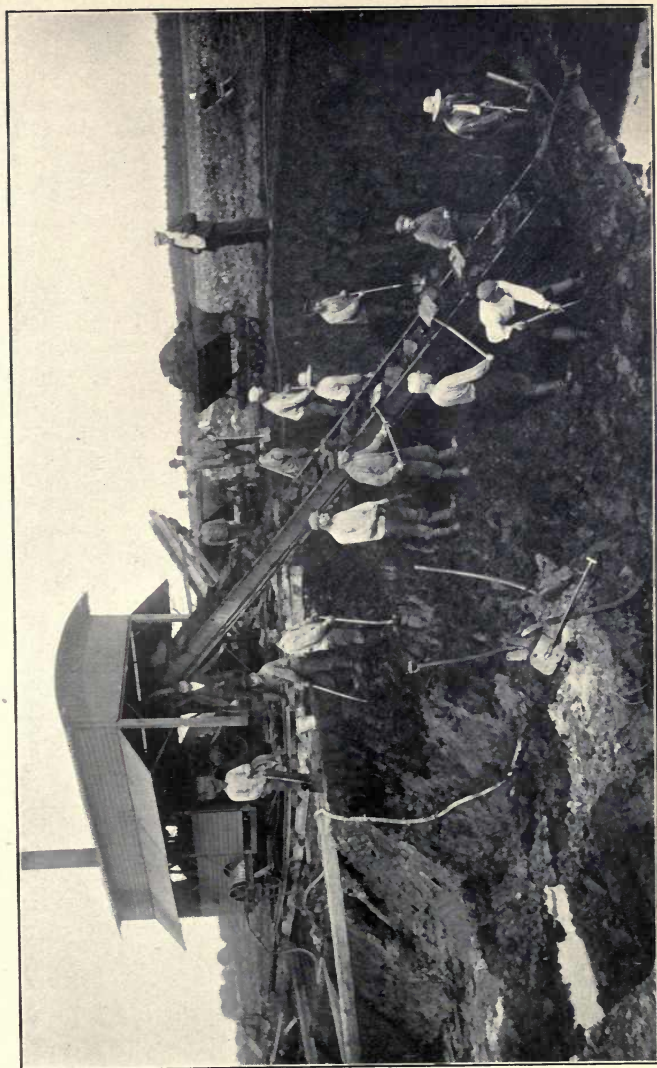
FIG. 129—Drainage ditch for drying field, St. Olof, Sweden.

The peat machines used are: one Anrep machine No. IB, made by Abjörn Anderson, Svedala, Sweden, and one machine manufactured by Munktell, Eskilstuna, Sweden. This latter firm formerly manufactured the machines constructed by Anrep and after the termination of the contract continued to manufacture peat machines slightly changed from Anrep's patents, but the changes made are no improvements.

The Anrep (Svedala) machine No. IB, (see Plates 21 and 22), is operated by a 42 h.p. locomobile, which also furnishes the power required to operate the mechanical arrangements for the transportation of the machined peat to the drying field, the field press and stump pulling apparatus.

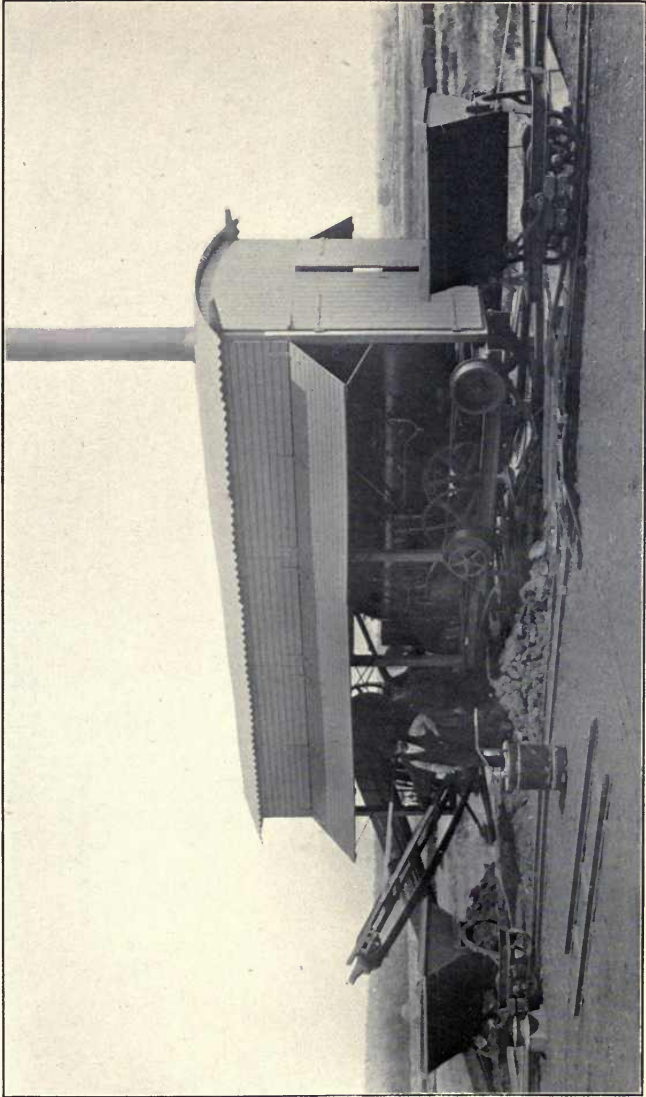
The spades used for digging the raw peat are shown in Plate 21 and the mechanical transport arrangement and field press in Plates 22, 23 and 24,

PLATE 21.



Anrep Peat Machine No. I. B. at St. Olof, Sweden.

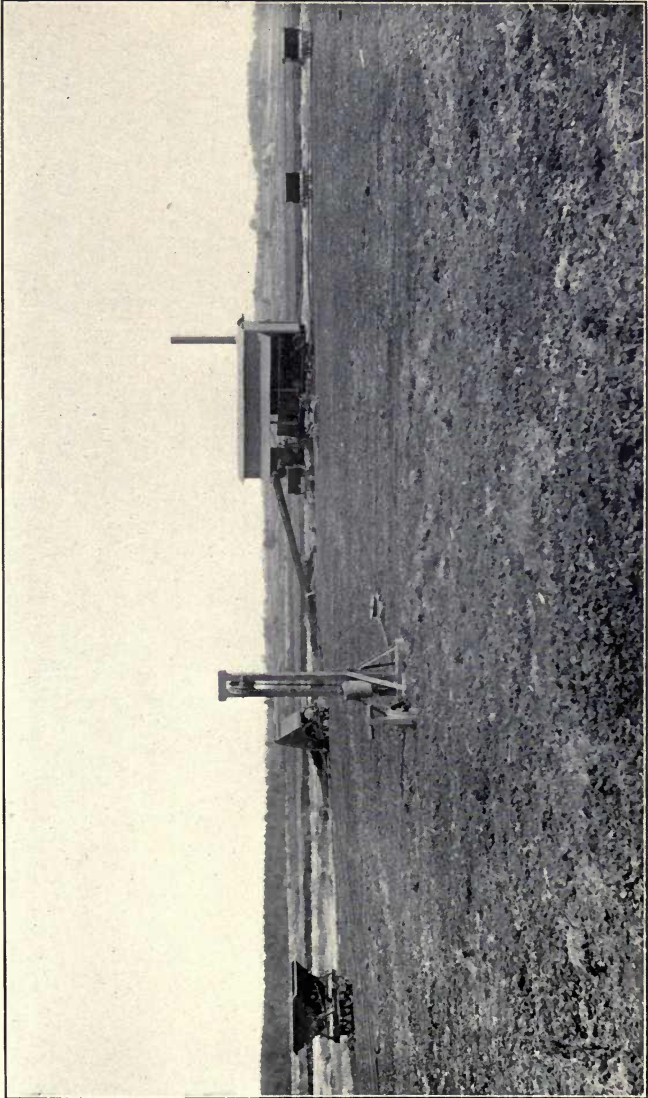




Anrep Peat Machine No. 1. B. at St. Olof, Sweden.



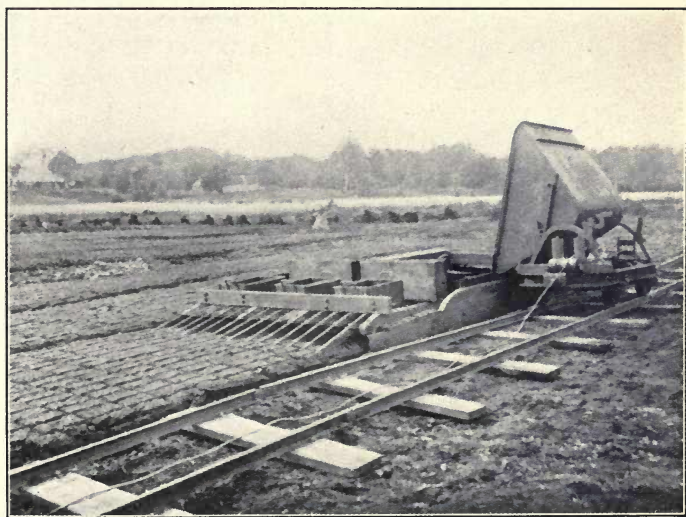




Cable Transportation of Machined Peat at St. Olof, Sweden.

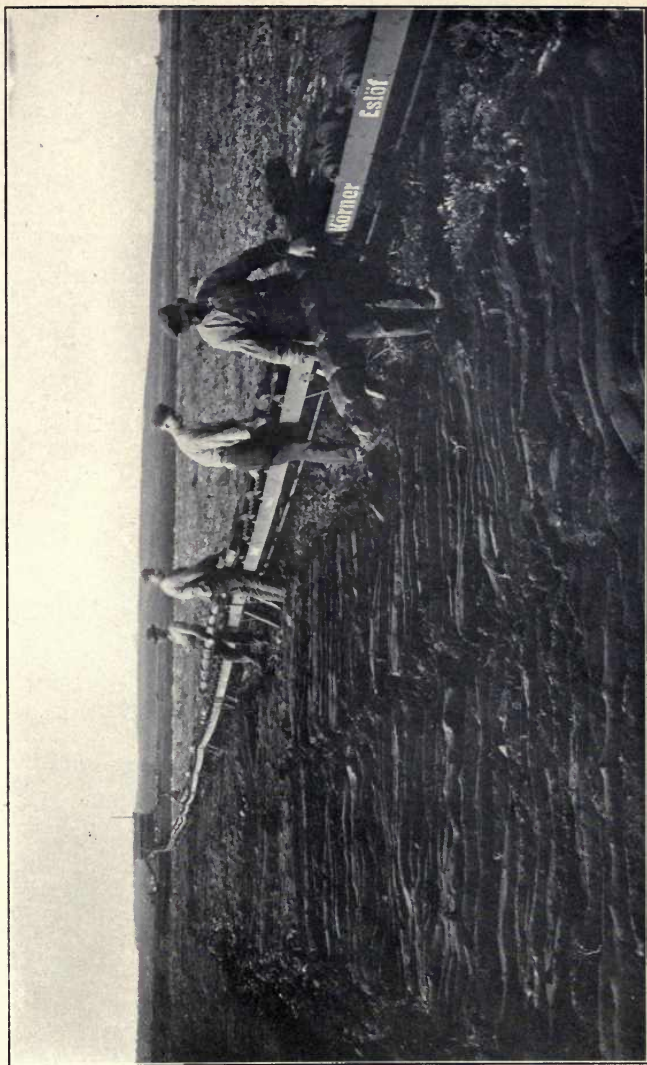


PLATE 24.



Jakobson's Fieldpress at St. Olof, Sweden.





A. Körner's Peat Pallet Conveyor at St. Olof, Sweden.



PLATE 26.



Peat Stack at St. Olof, Sweden.





and is further described on pages 94-95. The cars used are common dumping cars made of iron and holding about 0.8 cubic yards. The machined peat is conveyed by the belt conveyor and dumped into the cars, which, when filled, are clamped to the transport cable and hauled to the field press, shown in Plate 24, and further described on pages 94-95.

The production of this machine, used with the arrangements described, averaged during the season 1907, per day of 10 hours, 55 tons air-dried peat (about 25% moisture) and occasionally the output reached 60 tons.

The number of men employed was as follows; 1 engineer, 1 helper, 10 diggers, 1 for loading the cars and clamping them to the cable, 1 for dumping the peat into the field press, 1 levelling the peat in the field press, 1 cutting the peat laid out in suitable lengths, 1 for moving tracks, etc., and one boy for signalling—total: 17 men and 1 boy.

The dimensions of the peat bricks in wet condition were 8 x 5 x 5 inches and each brick air-dried weighed 1.3-1.5 lbs.

The Munktell machine was combined with a peat pallet conveyor 660 feet long for the laying out of the peat bricks on the drying field (see Plate 25). This conveyor, invented by A. Körner, is described on pages 96-97.

The engineers were paid 95 cents per day, the rest of the work was done by contract.

Labour cost:—	Cents per ton.
Digging, transportation and laying out the machined peat for drying .....	40.5
Turning the peat bricks. ....	3.0
Piling the peat bricks in heaps .....	7.0
Transportation and storing the dried peat .....	12.3
Transportation of the peat from storehouse to station and loading on cars. ....	8.0
Total.....	70.8

To this must be added the cost of the bog, for which in this case about \$150 per acre was paid, the interest, amortization, etc.

The yearly production was some 5,500 tons.

For transportation to the railway station an aerial tramway about two miles long was used, which was so arranged that the peat could be dumped directly into railway cars.

In cases where the dried peat could not be stored in the storehouse or sold at once, it was stacked in large stacks, as shown in Plate 26.

The price obtained per ton peat fuel f.o.b. St. Olof station was \$2.45, and the price paid for coal in this part of Sweden was \$5.00-\$5.40 per ton.

*Yxenhult, Sweden.*—The bog worked has an area of about 620 acres and a depth of 8-10 feet. Part of the bog consists of little humified sphagnum moss, which is used for the manufacture of moss litter. It is thoroughly drained and the peat used for the manufacture of peat fuel is of good quality, but tree stumps are plentiful in the bottom layer. The bog is worked with

two peat machines, one an Anrep machine No. IB, with mechanical transportation on parallel tracks, and Jakobson's field press; the other an older Anrep machine with two shafts and the usual arrangement for transportation and laying out for drying, described on page 90. With the latter machine the daily production, under normal conditions, averaged 40,000 peat bricks of the dimensions 5 x 5 x 13.2 inches in 10 hours, which is equal to about 44 tons air-dried peat with 25% moisture.

The volume of the raw peat required per ton air-dried peat was about 7 cubic yards. The number of men employed was 18 men, 4 boys, 1 engineer and 1 helper. The labour costs (not including engineer were):

	per 1,000 pieces, cents	Per ton, cents.
For digging, transportation and laying out. . . . .	60.8	55.3
For turning the peat bricks. . . . .	2.7	2.5
For piling the peat bricks in heaps. . . . .	4.6	4.2
For transportation of the dried peat to storehouse		16.0
	—	—
Total. . . . .		78.0
For stacking (when necessary). . . . .		15.0

The men employed at the Anrep machine No. IB were 16 men, 1 engineer and 1 helper.

The men here were paid 7 cents per cubic meter of raw peat dug out and treated, the engineer and helper 0.54 cents, which would make the labour cost per ton as follows:

	Per ton, cents
For digging, transportation and laying out. . . . .	41.1
For turning the peat bricks. . . . .	2.5
For piling the peat bricks in heaps. . . . .	4.2
For transportation of the dried peat to storehouses . . . . .	16.0
	—
Total. . . . .	63.8

The spades used for digging the raw peat had square edges, otherwise the tools and methods used were the same as those previously described. The peat bricks were piled up in heaps, as shown in Fig. 130, which was the method chiefly employed in Sweden.



FIG. 130—Peat heaps at Yxenhult, Sweden.

The price per ton peat fuel f.o.b. Yxenhult station was \$2.35.

At Emmalunga and a number of other plants in Sweden Anrep machines are also employed. The methods used and the labour costs and production at these plants are practically the same as those already given.

*Stafsjö\**.—During 1901 an Anrep machine with two shafts was at work in this bog. The daily production averaged 47 tons and the cost of production was in detail as follows, per 1,000 pieces=1,000 kg. or 2,200 lbs.

	Per ton, kronor
9 diggers, at 0.0728 kronor. . . . .	0.655
12 men for transport and laying out, at 0.0728 kronor . . . . .	0.874
2 men for loading, at 0.0728 kronor . . . . .	0.145
3 boys, at 0.0364 kronor. . . . .	0.109
Engineer, at 2.50 kronor per day. . . . .	0.054
Helper, at 2.00 kronor per day. . . . .	0.043-1.88
Turning and piling peat bricks. . . . .	0.14
Stacking. . . . .	0.14 -0.28
Transportation to storehouse. . . . .	0.46
Fuel for locomobile . . . . .	0.09
Oil . . . . .	0.03 -0.58
Total. . . . .	2.74 kronor=74 cents.

To this must be added:

	Per ton, kronor
Amortization and repairs . . . . .	0.45
Administration. . . . .	0.45
General expenses . . . . .	0.45
Loading on railway cars. . . . .	0.45
Total. . . . .	1.80 kronor = 50 cents.

The total cost of production was, therefore, \$1.24 per ton.

*Russia*.—The peat machines used in Russia are chiefly Anrep machines of older construction, with two shafts. Up to the present time, some 1,300† of these machines are employed. The new machines with one shaft have also lately been introduced. The largest peat industry in Russia is centered around Moscow, notwithstanding the fact that the climatic conditions are comparatively unfavourable and the working season short. The frost in the ground as a rule does not disappear before the end of May, and rains during the summer are frequent. The bogs generally contain a large number of roots and tree stumps, and require, therefore, strong and well constructed peat machines.

The mouthpieces on the Russian machines have 5.2 x 5.2 inches interior dimensions, and the peat is cut in lengths of 13.6 inches, each brick weighing, air-dried, about 2.75 lbs. With the old methods of transporting the peat pallets on cars on parallel tracks and laying them out for drying, the production per machine per day of 10 hours varies according to the nature

\* Report by Messrs. Wallgren & Larson.

† According to A. Anrep.

of the bog, between 40-60 tons air-dried peat. The number of men employed per machine is about 30, of which 12 are diggers, and the drying work is done by about 15 women per machine. The cost of production per ton peat fuel, including all expenses, stacked on the bog averages \$1.35 to \$1.40.

*Beuerberg, near Munich, Germany.*—The bog located at this place furnishes the raw material for the peat coking plant owned by der Oberbayerischen Kokswerke and erected, in accordance with M. Ziegler's patents, close to the bog.

The bog is chiefly a so-called high bog and contains, with the exception of the surface layer, well humified peat of good quality. Roots and stumps of trees are fairly plentiful. The area of the bog at present worked by 11 peat machines is some 175 acres, with an average depth of 8 to 10 feet. The main drainage ditches and arrangement of the plant are shown in Fig. 131. The peat machines used are of Heinen's, Schlickeysen's and Dolberg's construction, with side elevators. Heinen's and Dolberg's machines have their mouthpieces provided with two openings and deliver the wet peat with cross-sections 4.2 x 4.6 inches. The peat pallets used are 4 feet long and hold six peat bricks each. Schlickeysen's machines have mouthpieces with three openings. The spades used for digging the raw peat are shown in Fig. 132. The peat pallets are loaded on cars in three rows, which are transported to and from the drying field on round tracks. The average production for each machine for ten hours, employing 14 men, is 22 tons air-dried peat. The cost per ton peat at the coking plant was \$1.20 to \$1.75, and the wages of the men were on an average \$1.25-\$1.50 per day.

Each peat machine was run by a 20 h.p. electric motor. The electric energy was developed by two dynamos each of 128 K.W. driven by two locomobiles, which were fired with peat or with the waste gases from the coking retorts, and placed in a separate building close to the bog. The peat machines worked day and night, with two shifts of men. During the night electric light is used, both arc lamps and incandescent lamps being employed. Usually four arc lamps for each machine were sufficient. These lamps used the direct current of 440 volts which supplied the motors driving the peat machines. The location of the circuit which follows each working trench is shown in Fig. 131. The wires are hung up on poles, and at every 165 feet connections can be made with the motors to the various peat machines.

The employment of electric motors instead of locomobiles is undoubtedly a very practical arrangement at a plant where a number of peat machines are working. Each locomobile requires an engineer and a helper for carrying fuel and water, and the employment of these men is avoided where electric motors are used, the foreman for each machine attending to the switching on or off of the current. Furthermore, an electric motor is very much lighter and runs more quietly and with less vibration than a loco-

bile or a gasoline engine, which is sometimes used. This is important in bogs where the walls of the working trench have a tendency to cave in or crack.

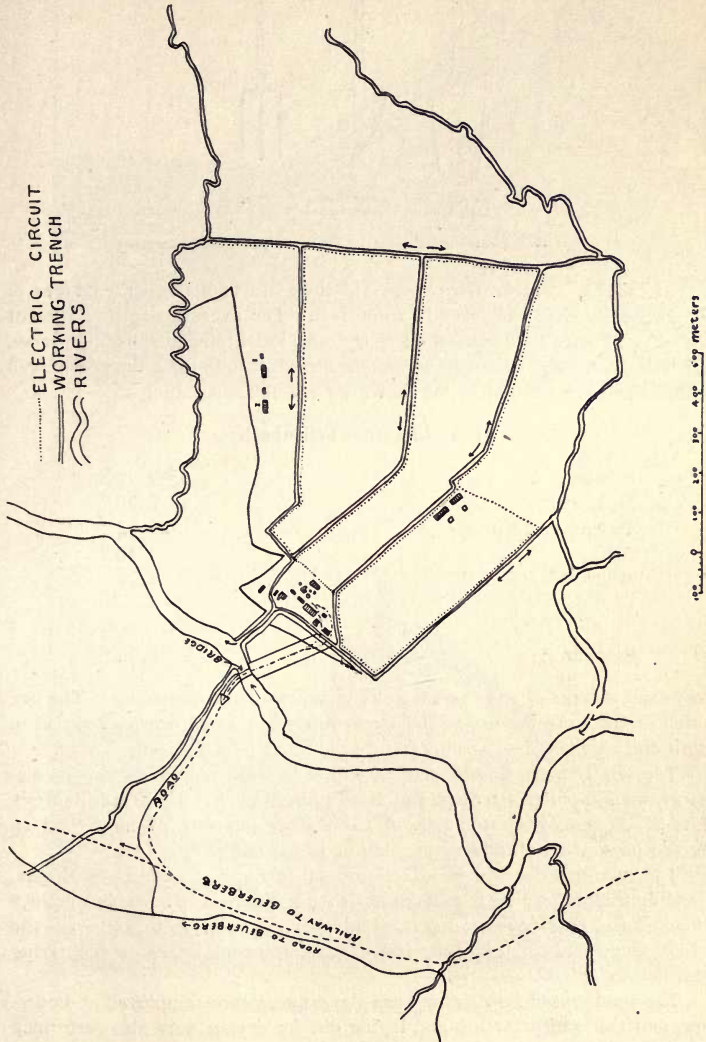


FIG. 131—Peat bog at Beuerberg, Germany.

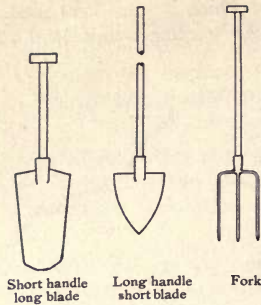


FIG. 132—Tools used for digging Peat at Beuerberg, Germany.

*Feilenbach, Bavaria, Germany.*—This bog is a high bog with an area of 740 acres and a depth of from 10 to 50 feet. The average depth at present worked is 21.5 feet. Part of the bog contains less humified sphagnum moss, which is used for the manufacture of moss litter, otherwise the peat is well humified and of good quality, as shown by the following analysis:—

Peat fuel from Feilenbach:

Carbon .....	49.19%
Hydrogen .....	5.30 "
Oxygen and Nitrogen .....	29.62 "
Ash .....	1.16 "
Moisture .....	14.73 "
<hr/>	
Total .....	100.00%
Sulphur .....	0.13 "

Roots and stumps of trees occur, but not in very large quantities. The bog is well drained and the drying fields are drained by small ditches 2.6 feet in depth and about 30 feet apart.

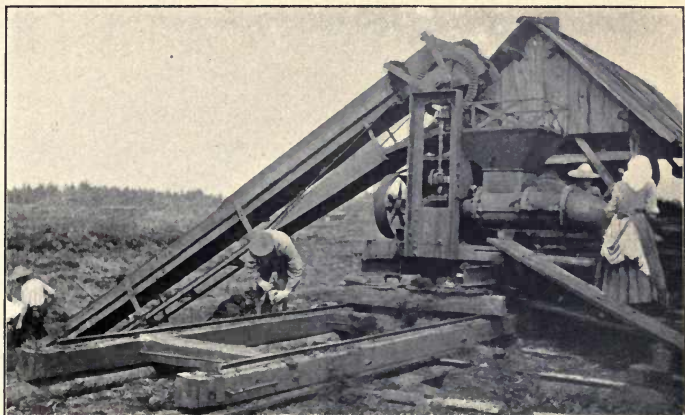
The bog is worked by 9 peat machines of Dolberg type, with side elevators, manufactured by Sugg and Krauss, in Munich. Each machine (see Plate 27) is run by a locomobile of 16–18 h.p., and with 17 men gives an average production of 22 tons per day of 10 hours.

The men are distributed as follows:—1 engineer, 1 helper,\* 5 diggers, 1 putting the peat pallets in position,\* 1 cutting the peat in suitable lengths,\* 2 loading the peat pallets on cars, 4 transporting the cars to and from the drying field, and 2 unloading and placing the peat bricks on the drying field.

The spades used for digging were the same as those employed at Beuerberg, and the transportation and laying out for drying were also performed

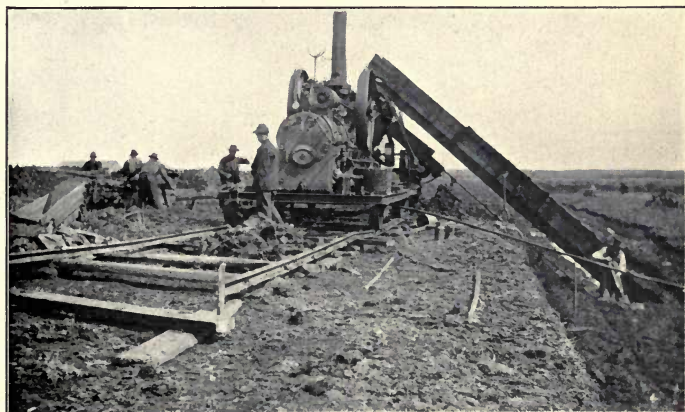
\* At Feilenbach this work was done by women.

PLATE 27.



Peat Machine at Feilenbach, Germany.

PLATE 28.



Peat Machine at Triangel, Germany.





in a similar manner. The mouthpieces to the machines had two openings 4 x 4.8 inches, and the peat was taken up on pallets 52 inches in length and 10.2 inches in width. Each pallet contained 6 peat bricks of the dimensions 4 x 4.8 x 17.3 inches.

The men were paid 16 marks per 1,000 peat pallets=6,000 peat bricks, laid out for drying. Of this amount they received only 15.25 marks each pay day and the balance, 0.75 marks, was held back until the season was over and then paid only to those who had remained the time agreed upon.

The amount paid per 1,000 pallets each pay day was distributed as follows:—

Engineer . . . . .	at 1.26 marks . . . . .	1.26 marks
Diggers . . . . .	at 0.97 " . . . . .	4.85 "
Pallet placer . . . . .	at 0.46 " . . . . .	0.46 "
Peat cutter . . . . .	at 0.46 " . . . . .	0.46 "
Loading men . . . . .	at 1.07 " . . . . .	2.14 "
Transporting men . . . . .	at 0.94 " . . . . .	3.76 "
Unloading men . . . . .	at 0.88 " . . . . .	1.76 "
Helper . . . . .	at 0.56 " . . . . .	0.56 "

Total . . . . . 15.25 marks

The peat bricks weighed, air-dried, on an average 1.75 lbs., which would make the cost per ton air-dried peat, layed out for drying, about 3 marks=72 cents.

Including all expenses, the cost per ton f. o. b. Ober Aibling station was given as \$2.40, which is exceedingly high. The men made, on an average, a little over \$1.00 per day.

The dried peat was brought from the bog to the railway station by means of small locomotives on a narrow gauged railway.

The yearly production at this plant averages 15,000 tons and the price obtained per ton peat fuel f. o. b. Ober Aibling was \$3.50.

The price of coal in this part of Germany was \$6.20 to \$6.50 per ton.

*Triangel, near Gifhorn, Germany.*—This bog has an area of some 3,000 acres and an average depth of 13 to 16 feet. It is owned by "der Norddeutschen Torfmoor Aktiengesellschaft" (A. Rimpau of Braunschweig). Every part of the bog not used at present for the manufacture of peat fuel, moss litter or peat mull is cultivated, and the results obtained by the methods employed have been exceedingly favourable.

The bog is a high bog with a surface layer of 3-4 feet of sphagnum moss, which is used as a raw material for moss litter manufacture. The drainage is accomplished by a large ditch cutting through the bog and by side ditches, so that it is thoroughly drained to the bottom, which is used for drying field or brought under cultivation at the rate the bog is worked out. A permanent track of normal gauge is laid down on the side of the main drainage ditch, and the peat fuel and other peat products manufactured loaded directly on railway cars, avoiding any reloading at the station.

At present two plants for the manufacture of moss litter and peat mull and 10 peat machines are in operation during the season.

Most of the peat machines as well as the moss litter plants are furnished with the required power from a central power station of 200 h.p. capacity. The power is developed by two steam engines and dynamos furnishing a current of 3,000 volts to the transformers placed in a building close to the spot where the peat machines are working. The current is here transformed to 500 volts and delivered by a suitable circuit to the different motors.

The boilers in the power plant are fired with a poor quality of peat fuel and refuse on step grates.

The peat machines used are chiefly of the type manufactured by Königs-hütte in Lauterberg, with only one screw shaft and mouthpieces with one opening. Some of Heinen's machines with two shafts and driven by locomobiles (see Plate 28) were also used.

The machines were working in trenches at right angles to the main drainage ditch, about 1,000 feet apart, and on both sides of same.

The number of men employed at each machine was as follows:—

4 diggers, 1 boy putting the peat pallets in position, 1 man cutting the peat in suitable lengths, 1 loading the peat pallets, 3 transporting the cars to and from the drying field and 3 unloading and placing the peat bricks for drying. Total, 12 men and 1 boy. At the machines run by locomobiles one engineer and a helper were also employed.

The capacity of each machine\* with the above number of men was 4,000 peat bricks of 4.8 x 5.2 x 10 inches in wet dimensions per hour, which corresponds to 3,740–3,960 lbs. air-dry peat, or per day of 10 hours 18.7–19.8 tons.

The method described on page 88, was used for transporting and laying out the peat bricks for drying.

The labour cost per ton air-dried peat stacked on the bog averaged 98 cents.

\* Part of the peat fuel produced is manufactured into peat coke, which sells for \$9.00 to \$10.00 per ton.

*O. Strenge's Peat Plant at Elisabethfehn, Oldenburg, Germany.*—Strenge's peat machine is combined with a mechanical excavator and spreading apparatus, all of which are patented by him.

Fig. 133 shows a front view of the plant, and Fig. 134 a plan of same.

The peat machine, (4,) with its conveyors (2, 3, 5,) and motor (17,) are placed on a strong movable truck (7,) also supplied with a frame work (see Figs. 133 and 135) which partly carries, by means of cables, the spreader (6) and conveyors. The conveyor conveying the raw peat to the peat machine and carrying the excavator is supplied with a movable trestle running on wheels on an iron plate in the trench (see Figs. 133, 134 and 136).

\* Hausding, Handbuch der Torfgewinnung.

FIG. 133  
FRONT VIEW

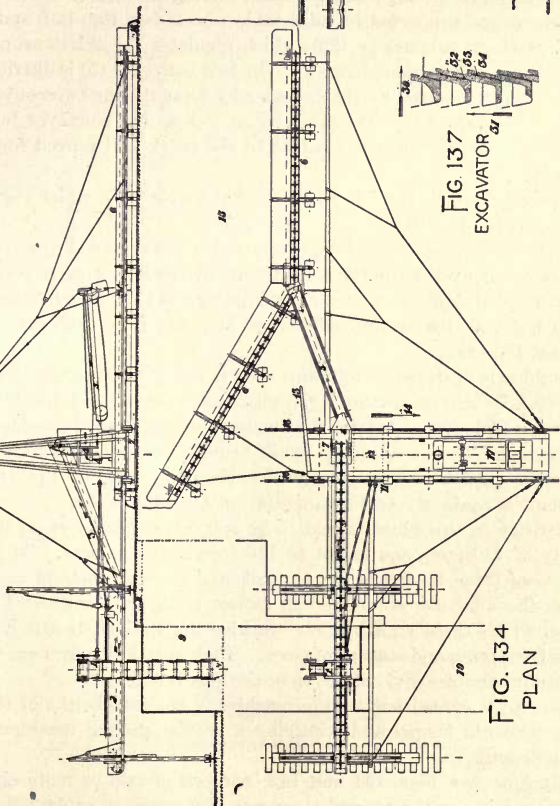


FIG. 134  
PLAN

FIG. 138  
EXCAVATOR

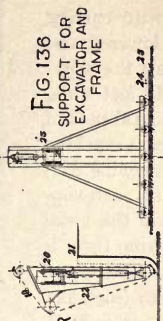


FIG. 135  
SIDE VIEW  
OF TRUCK

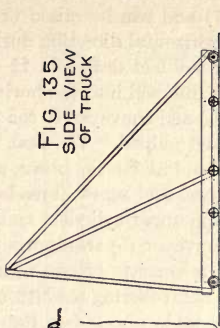


FIG. 137  
EXCAVATOR



FIG. 139 SPREADER

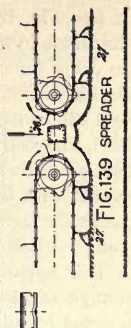


FIG. 140 SPREADER



O. STRENGE'S PEAT PLANT, ELISABETHFEHN, GERMANY.

1. Excavator. 2. Conveyor. 3. Conveyor. 4. Peat Machine. 5. Conveyor. 6. Spreader. 7. Truck. 8. Surface layer of bog. 9. Peat suitable for fuel manufacture. 10. Working trench. 11. Station for driver. 12. Driving arrangement for shafts. 13. Driving device for spreader. 14. Direction in which plant is moved. 15. Drying field with peat mass spread out. 16. Track. 17. Locomobile (or other motor). 18. Peat mass spread out for drying. 19. Excavator chain. 20. Guide for excavator frame. 21. Screw hoist. 22. Support for excavator. 23. Support for conveyor and frame. 24. Iron plates. 25. Ties. 26. Peat mass falling from conveyor to spreader. 27. Peat mass spread out. 28. Guide for chain. 29. Carriage. 30. Direction in which excavator is moved on its frame. 31. Direction in which excavator moves. 32. Peat bed. 33. Buckets. 34. Cutting knife.

The excavator (1) consists of iron buckets (33) provided with cutting knives (34) placed in front (see Fig. 137) and can be raised or lowered and moved back and forth on its frame in a horizontal direction during the work. It is usually constructed to cut a trench 8–9 feet deep and 11–12 feet wide. The raw peat cut out by the excavator is dumped into the horizontal part of the conveyor (2, 3), (see Figs. 133 and 134) and conveyed to the peat machine (4), where it is further mixed, kneaded and pulped. The peat machine consists of two double cylinders, one pair placed above the other, and each supplied with two shafts provided with knives and screw threads in the usual manner. The peat first passes through the upper cylinders and from there is passed through the lower one. A belt conveyor (5) transports the machined peat to the spreader (6). This apparatus consists of two frames (see Figs. 133 and 134) placed at an angle of  $145^\circ$  and covering a width of some 60–70 feet. The frames are supported by adjustable wheels (see Fig. 140) and supplied with a platform or carriage (29), which regulates the thickness of the peat mass laid out. The peat delivered by the belt conveyor (5) is distributed over the entire width covered by the spreader by means of the two conveyors (6), (see Figs. 134 and 139). The spreader as well as the conveyor for the raw peat are fastened by means of cables to the truck and moved forward simultaneously.

The required power is furnished by a 45 h.p. motor (17), which is generally a compound locomobile.

The whole machine is moved forward by motor power and the excavator, belt conveyor and conveyors on the spreader are driven by means of telescoping partly suspended shafts with universal couplings, so that even if the different parts of the machine are moved somewhat apart from each other, the working is not impeded.

The machine is operated as follows:—When the excavator has reached the edge of the trench, its motion is automatically stopped and the plant is moved forward 14 inches, whereby the buckets are made to excavate this length of the bog. The excavator is again brought into operation and the work continued until the excavator reaches the inner side of the trench, when the plant is again moved forward and so on continuously.

The capacity of this plant is said to be some 1,000 cubic yards of raw peat per day of 13 hours, equivalent to 110 tons air-dried peat. At Elisabethfehn two of these machines are at work and at Schwaneburg another. The price of the machine, not including motor, is 30,000 marks = \$7,200. The bogs on which these machines are working are drained to the bottom and are free from roots and stumps of trees. Their suitability for bogs where roots and stumps are plentiful has yet to be demonstrated.

The peat layer spread out by the machine is cut into bricks of the required dimensions in length and width by a special cutting machine, also patented by Strenge.

This machine (see Figs. 141 and 142) consists of two or more circular steel plates revolving on a shaft and is operated by means of cables (6) and a double winch (1) driven by a motor (2).

Fig. 141—Side View.

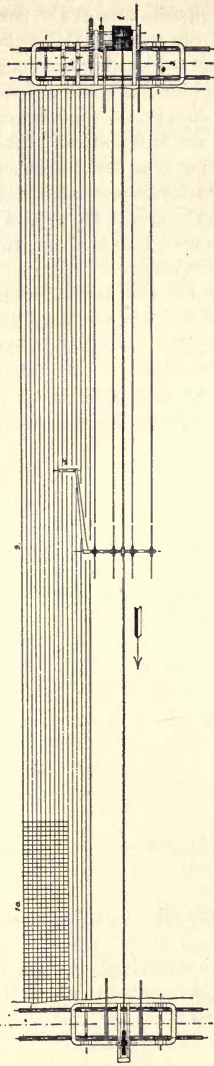
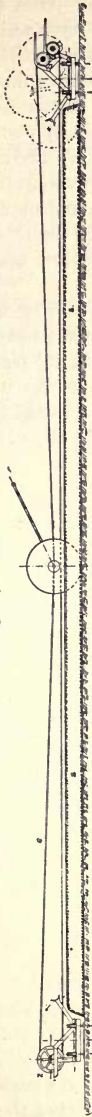


Fig. 142—Plan.

## O. STRENGE'S PEAT-CUTTING MACHINE.

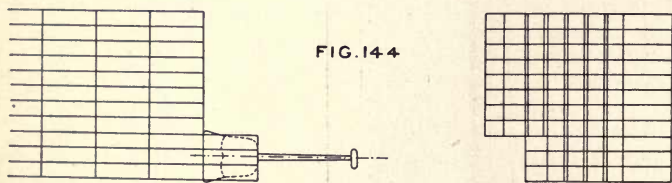
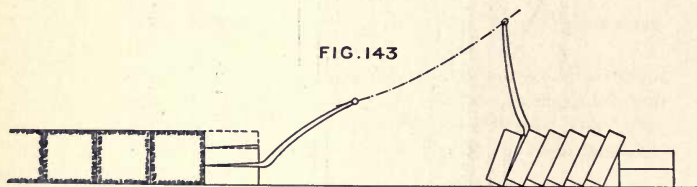
1. Drum for cable. 2. Motor. 3. Truck. 4. Catch fork. 5. Steering guide. 6. Cable. 7. Pulley.
8. Peat mass spread out. 9. Peat mass cut in one direction. 10. Peat mass cut in two directions.

The motor of 6-8 h.p. is mounted on the same truck (3) as the winch, which it drives. On the opposite side of the peat layer which is to be cut is another truck carrying a rope pulley (7), around which the cable runs, so that the cutting machine can work either from one side or the other.

When the cutting machine has traversed the distance between the two trucks, which are movable on rails, the shaft is caught by two forks (4) turning on pivots and the cutters are automatically lifted up above the peat layer. At the same time the driving gear is automatically stopped and the cutting machine is held in place by a brake preventing it from dropping back. While the cutters are thus raised, the trucks are moved the required distance. The cutters are then slowly lowered into the peat layer and again started in an opposite direction to the previous cut.

The distance between the two tracks, when cutting the peat longitudinally, is usually 132 feet and when cutting it cross-ways 65-70 feet. One man steers the cutting machine by means of a handle (5) placed on the shaft.

After the peat layer has been cut by this machine, it is cut by hand (see Figs. 143 and 144) in suitable thicknesses and raised up for drying, as shown in the figures. The number of men required to attend the peat machine and cutting the peat is 13 to 17.



Later the peat bricks are piled up in heaps and dried in the usual manner by extra labour.

According to information received, the cost per ton air-dried peat at the bog, including all expenses, amounted to about 70 cents, when the men made about \$1.50 per day. Loaded on barges at the canal, which cuts through the bog, the selling price was \$2.20 per ton.

Most of the peat fuel manufactured by the method described on page 56 is used as raw material in the peat-coking plant erected close to the bog at Elisabethfehn.

*R. Dolberg's Peat Plants\** with the number of men and the arrangements given in the following tables have the following capacities in bogs containing peat of suitable quality:—

*In Drained Bogs.*

(The raw peat dug out of the bog with spades by hand.)

Daily Production.		Number of machine	Transport of raw material to the peat machine.	Transport of machined peat to the drying field.	Number of men required. Approximate.	Motor required.
Pieces 4 x 4 x 8 inches.	Tons approximate.					
10-12,000	4.5- 5.4	3a	Wheelbarrows or cars on portable tracks.	Wheelbarrows or cars on portable tracks.	6	1 horse
18-25,000	8.1-11.3	2	do	do.	10	2 horses
30-40,000	13.5-18.0	1a	Cars on portable tracks.	Cars on portable tracks.	10-12	4-6 h.p.
60-80,000	27-36	1b	Elevator	do.	15-18	15-18 h.p.
60-80,000	27-36	1c	do.	do.	15-18	21-28 h.p.

*In Wet Bogs.*

(The raw peat dug out of the bog with cutting machines.)

Daily Production.		Number of machine	Transport of raw material to the peat machine.	Transport of machined peat to the drying field.	Number of men required. Approximate.	Motor required.
Pieces 4 x 4 x 8 inches.	Tons approximate.					
10-12,000	4.5- 5.4	3a	Wheelbarrows or cars on portable tracks.	Wheelbarrows or cars on portable tracks.	7	1 horse
18-25,000	8.1-11.3	2	do.	do.	12	2 horses
30-40,000	13.5-18.0	1a	Cars on portable tracks.	Cars on portable tracks.	14	4-6 h.p.
60-80,000	27-36	1b	do.	do.	25-28	15-18 h.p.
60-80,000	27-36	1c	do.	do.	25-28	21-28 h.p.
60-80,000	27-36	1b	Cutting machines run by motor power with elevators.	do.	13-15	28 h.p.

The weight of one cubic yard machine-shaped peat varies† between 495—693 lbs.

\* According to R. Dolberg.

† According to the Swedish Peat Society.

## COST OF PLANTS.

The cost of the different apparatus required for the treatment of the peat varies considerably, depending on the methods used and the machinery employed. The main point, however, is to employ a machine which delivers a well treated material, and in most cases the best and cheapest fuel is produced by the best constructed machine, although these machines, as a rule, are more expensive. The machinery employed should also be suitable for the production aimed at, and as a rule the larger the capacity of the peat machine, the fewer workmen are required for a certain production and the smaller is the cost of production.

In the following, detailed costs are given of the machinery and apparatus required at plants where the Anrep machines Nos. I B and II B are employed, with approximate daily capacities for 10 hours\* of 49-65 tons and 33-44 tons respectively of air-dried peat, also costs of plants where Heinen's machines Nos. T-1 and T-2 W are employed, with approximate daily capacities for 10 hours† of 13-17 tons and 26-34 tons respectively of air-dried peat.

---

\* According to Abjörn Anderson, Svedala, Sweden.

† According to A. Heinen, Varel, Germany.



*Price List of Peat Fuel Machinery Manufactured by Abjörn Andersson's Mekaniska Verkstads Aktiebolag, Svedala, Sweden.*  
*Plants with Peat Machine Anrep-Svedala No. 1 B.*

Transporting the Machined Peat by Hand on Parallel tracks. (Cars with Peat Pallets.)		Transporting the Machined Peat by Cable on Round Track. (Cars with Peat Pallets.)		Transporting the Machined Peat by Cable on Round Track and laying out with Jakobson's Field Press.	
Weight, lbs.	Kronor*	Weight, lbs.	Kronor*	Weight, lbs.	Kronor*
Peat machine 1 B complete with a 33 feet long elevator, normal mouthpiece 5 x 5.2 inches, rolling table, truck with brakes and large enough for motor. . . . .	11220	4400	4400	do. with adjustable mouthpiece and a 40 ft. long elevator . . . . .	4600
Winch for moving the plant and for stump raising, with anchor and cables. . . . .	1980	700	700	do.	700
Pump or ejector, 33 feet long, 1 1/2" spiral hose, foot valve and water tank. . . . .	660	400	400	do.	400
Shed over platform with roof of corrugated sheet-iron and removable walls. . . . .	2640	450	450	do.	450
33 yards heavy rails with fish-plates in lengths of 3.3 yards	1540	225	225	do.	225
18 ties 4" x 9" x 12' (pine) . . . . .	1980	90	120	30 do.	150
<i>For the transportation and laying out for drying (width of drying field 578 feet.)</i>					
1485 feet portable steel tracks with 24 inches gauge made in sections of 16.5 feet, fish-plates and riveted steel ties .	11880	1035	16500	do.	1437
2 curves, 1/4 circle. . . . .	550	180	1980	16.5 feet track in 8.25 foot lengths. . . . .	18
2 curves, 1/2 circle. . . . .	660	220	2063 do.	4 curves with cable rollers	480
				Driving apparatus with couplings and with frame of steel beams to be fastened on the truck to the peat machine . . . . .	750
				Driving apparatus with couplings, etc. . . . .	750

Price List of Peat Fuel Machinery—Plants with Peat Machine Anrep-Svedala No. I B—(Continued)

Transporting the Machined Peat by Hand on Parallel tracks. (Cars with Peat Pallets.)		Transporting the Machined Peat by Cable on Round Track. (Cars with Peat Pallets.)		Transporting the Machined Peat by Cable on Round Track and laying out with Jakobson's Field Press.	
Weight, lbs.	Kronor*	Weight, lbs.	Kronor*	Weight, lbs.	Kronor*
8 cars for transport of peat bricks, with ball bearings and double flanged steel wheels.....	2640	1980 feet cable.....	1 330	do. ....	330
300 peat pallets 0.88 x 6.4 x 61.2 inches.....	2640	Station car with pulleys, chain and anchor.....	990	do. ....	375
Total.....	38390	Cable stretching apparatus, with anchor, pulleys and weights.....	660	do. ....	150
Motor†	15070	8 cars for transport of peat with ball bearings and double flanged steel wheels.....	2640	10 dumping cars do....	8250
Locomotive of 42 h.p.....	6500	8 couplings for cable.....	880	10 do.....	1100
Total.....	53460	300 peat pallets 0.88 x 6.4 x 61.2 inches.....	2640	Field press with winch, chains, anchors, etc....	3960
	lbs.	Total.....	49060	Total.....	57750
	53460	Motor†	15070	Locomotive of 42 h.p. ....	6500
	kronor	Locomotive of 42 h.p. ....	6500	Total.....	19585
	15370	Total.....	17777	lbs.	72820
	15370	Motor†	15070	kronor	19585

Number of men required, appr., 22 men, 2 boys.  
 Daily production per 10 hours, appr., 49 tons air-dried peat.  
 Peat fuel for locomobile, 8.8 lbs. per h.p. hour.

\* 1 kronor=27 cents.  
 † Instead of locomobile an electric motor or other suitable motor can be used.

19 men, 1 boy.  
 65 tons air-dried peat.  
 8.8 lbs. per h.p. hour.

Transporting the Machined Peat by Hand on Parallel tracks. (Cars with Peat Pallets.)	Weight lbs.	Kronor*	Transporting the Machined Peat by Cable on Round Track. (Cars with Peat Pallets.)	Weight lbs.	Kronor*	Transporting the Machined Peat by Cable on Round Track and laying out with Jakobson's Field Press.	Weight lbs.	Kronor*
Peat machine II B complete with a 26.5 feet long elevator, normal mouthpiece 5 x 5.2 inches, rolling table, truck with brakes and large enough for motor . . . . .	8140	2800	do . . . . .	8140	2800	do. with adjustable <sup>m</sup> mouthpiece and a 33 feet long elevator. . . . .	9020	2950
Winch for moving the plant and for stump raising, with anchor and cables. . . . .	1650	450	do. . . . .	1650	450	do. . . . .	1650	450
Pump or ejector, 33 feet long 1 1/2" spiral hose, foot valve and water tank. . . . .	550	350	do. . . . .	550	350	do. . . . .	550	350
Shed over platform with roof of corrugated iron and removable walls. . . . .	2420	400	do. . . . .	2420	400	do. . . . .	2420	400
33 yards heavy rails with fish-plates in length of 3.3 yards..	1375	200	do. . . . .	1375	200	do. . . . .	1375	200
15 ties 3" x 8" x 12' (pine) . . . .	1320	60	20 do. . . . .	1760	80	25 do. . . . .	2200	100
<i>For the transportation and laying out for drying ( width of drying field 495 fe et.)</i>								
1320 feet portable steel tracks with 24" gauge, made in *sections of 16.5 feet, with fish-plates and riveted steel ties . . . . .	10560	920	1815 do. . . . .	14520	1265	do. . . . .	14520	1265
2 curves, 1/4 circle. . . . .	550	180	4 curves with cable rollers couplings and with frame of steel beams to be fastened on the truck to the peat machine . . . . .	1980	480	16.5 feet do. in 8.25 feet lengths . . . . .	1980	18
2 curves, 1/2 circle. . . . .	660	220				do. . . . .		480
				1760	750	do. . . . .	1760	750

*Plants with Peat Machine Anrep-Svedala No. II B—(Continued)*

Transporting the Machined Peat by Hand on Parallel tracks. (Cars with Peat Pallets.)		Transporting the Machined Peat by Cable on Round Track. (Cars with Peat Pallets.)		Transporting the Machined Peat by Cable on Round Track and laying out with Jakobson's Field Press.	
Weight, lbs.	Kronor*	Weight, lbs.	Kronor*	Weight, lbs.	Kronor*
1650 feet cable . . . . .		1650 feet cable . . . . .	275	1716 feet do . . . . .	286
Station car with pulleys, chain and anchor . . . . .		Station car with pulleys, chain and anchor . . . . .	990	do . . . . .	990
Cable stretching apparatus with anchor, pulleys and weights . . . . .		Cable stretching apparatus with anchor, pulleys and weights . . . . .	660	do . . . . .	660
6 cars for transport of peat with ball bearings and double flanged steel wheels . . . . .	810	6 cars for transport of peat with ball bearings and double flanged steel wheels . . . . .		8 dumping cars do . . . . .	6600
6 couplings for cable . . . . .		6 couplings for cable . . . . .	660	8 do . . . . .	880
250 peat pallets 0.88 x 61.2 inches . . . . .	2200	250 peat pallets 0.88 x 6.4 x 61.2 inches . . . . .	2200	Field press with winch, chains, anchors, etc. . . . .	3960
Total . . . . .	31075	Total . . . . .	40590	Total . . . . .	48851
Motor† . . . . .		Motor† . . . . .		Motor† . . . . .	
Locomobile of 34 h.p. . . . .	11022	Locomobile of 34 h.p. . . . .	11022	Locomobile of 34 h.p. . . . .	11022
Total . . . . .	lbs. 42097	Total . . . . .	lbs. 51612	Total . . . . .	lbs. 59873
	kronor 11565		kronor 13775		kronor 15548

Number of men required, appr. 15 men, 2 boys.  
 Daily production per 10 hours, appr. 33 tons air-dried peat.  
 Peat fuel for locomobile, appr. 8.8 lbs. per h.p. hour.

12 men, 1 boy.  
 33 tons air-dried peat.  
 8.8 lbs. per h.p. hour.

13 men, 1 boy.  
 44 tons air-dried peat.  
 8.8 lbs. per h.p. hour.

\* 1 Krona=27 cents.  
 † Instead of locomobile an electric motor or other suitable motor may be used.

*Price list of peat fuel machinery manufactured by A. Heinen Maschinen fabrik,  
Varel, Oldenburg, Germany.*

*Plants with peat machine No. T I* (see description page 73).

The machined peat is transported by hand on a track with one siding on cars with peat pallets, see page 88.

	Marks*.
Peat machine No. T I, with one mixing apparatus, 20 feet long elevator, mouthpiece, rolling table and reserve parts . . . . .	2,000
Spades, ties, peat pallets, pails, tools, etc. . . . .	200
Rails for peat machine, etc. . . . .	180
Portable tracks for transportation of the machined peat to drying field, about 500 feet (including siding). . . . .	520
3 cars for transport of the peat pallets. . . . .	300
Locomotive of 5-8 h.p. . . . .	3,000

Total . . . . . 6,200

Production with 13 men, 13-17 tons air-dried peat in 10 hours.

*Plants with peat machine No. T 2 W.* (see description page 74).

The machined peat is transported by hand on a track with one siding on cars with peat pallets.

	Marks.
Peat machine No. T 2 W with two mixing appara- tuses, 33 feet long elevator, etc. . . . .	4,250
Spades, ties, peat pallets, etc. . . . .	350
Rails for peat machine, etc. . . . .	250
Portable tracks, about 660 feet (including siding)	650
4 cars for transport of the peat pallets. . . . .	400
Locomotive of 8-10 h.p. . . . .	3,850

Total . . . . . 9,750

Production with 16 men, 26-34 tons air-dried peat in 10 hours.

At a properly equipped peat plant the dried peat is transported on cars running on portable tracks on the drying field and from there on to a permanent track to loading station or storehouse. The cost of these items varies naturally with the lengths of the tracks required and with other local conditions.

\* 1 mark=24 cents.

*Approximate Cost of Production of Machine-formed Peat Fuel under Canadian Conditions with Anrep's Machine No. IB combined with Mechanical Transportation and Jakobson's Field Press.*

Assuming:—

The cost of a bog, which after drainage has an average depth of 9 feet, to be \$10 per acre, the cost of a 500 acre bog is . . . . .	\$5,000
The cost of main drainage of the bog to be . . . . .	3,000
The bog to be worked by two peat machines, each with a daily production of 60 tons air-dried peat, the cost of two such peat machines with necessary appliances and arrangements is in Sweden \$10-600 and allowing 25% higher price in Canada . .	13,250
Tracks and store-houses for dried peat . . . . .	4,000
Dormitories and boarding house for workmen . . . . .	1,500
Working capital and unforeseen expenditure. . . . .	10,250
	\$37,000
Total capital required. . . . .	\$37,000

The season suitable for the manufacture of air-dried peat fuel in southern Canada is probably as long as in any European country, or on an average about 100 working days, (from the time the frost leaves the ground until some time in August).

With two peat machines the yearly production should, therefore, amount to 12,000 tons peat fuel, when the work is proceeding under normal conditions.

A bog of the assumed area and average depth contains raw material for approximately 900,000 tons air-dried peat fuel, and with a yearly production of 12,000 tons would last 75 years.

Each machine requires 19 men and 1 boy, or say 20 men, one of whom is foreman. Assuming that the foreman makes \$2.00 a day and the rest of the men \$1.50, the cost per ton air-dried peat laid out for drying is . . . . .	51 cents
The drying work of raising, piling, stacking or storing the peat, for which boys and women are usually employed, costs in Europe not more than 25 cents per ton, but assuming double the cost in Canada, this would amount to . . . . .	50 cents
Assuming further that 4 extra men are employed for drainage and levelling of the drying fields and for various other jobs, at \$1.50 per day or per ton. . . . .	5 cents
making the total labour charges per ton air dried peat \$1.06.	
Fuel and oil for locomobile and machinery . . . . .	4 cents
Interest 5%, amortization 5%, 10% of the capital \$37,000 or \$3,700 . . . . .	31 cents

	Per ton.
Maintenance and repairs of machinery and buildings, 20% of \$18,750 or \$3,750 .....	31 cents.
Loading on railway cars .....	10 cents.
General expenses .....	18 cents.
	<hr/>
Total cost per ton peat fuel* .....	\$2.00

With a selling price of \$2.25 per ton f.o.b. loading station, a yearly profit of \$3,000 should be obtained, or a total interest of 13% on the assumed capital:

\* The figures here given referring to the cost of production depend naturally on local conditions and will probably be considerably decreased in many cases.

## CHAPTER IV.

## MANUFACTURE OF PEAT AND LIGNITE BRIQUETTES.

The methods employed for the manufacture of peat and lignite briquettes are practically identical and a plant constructed for the manufacture of one of these products is, with some unimportant alterations, also suitable for the other.

The manufacture of lignite briquettes has in Germany, reached very large proportions and more than 100 plants\* with more than 800 briquette presses are at present in operation in that country. The production of lignite in Germany is about sixty million tons annually and about half of this is briquetted and used both for domestic and industrial purposes.

The lignite used for briquetting is of the brown earthy variety and that having a wooden structure must be carefully removed.

Formerly the fine material was left in the mines or on the waste dumps and only the lumps, amounting to some 15%–20% of the material mined, were used. At present all the lignite mined is used, and as a rule the fine material is transported by means of aerial tramways to the plants, where it is used for steam-raising in specially constructed fire-boxes or else briquetted.

The lignite, as it comes from the mines in Germany, contains from 48 to 62% moisture, and the cost of same varies from 0.22–1.65 marks per cubic yard. The weight per cubic yard varies between 1,072–1,237 lbs., and from 3.64 to 4.24 cubic yards are required per ton briquettes, depending on its content of moisture. The average price for the raw lignite at the briquetting plants is 0.70–0.95 marks per ton.

Peat of good quality, i.e., heavy and well humified, when dried to some 50% moisture, is very similar to the lignite as it comes from the mines, and with the successful improvements made in the briquetting plants for lignite, the idea of treating peat in the same manner is near at hand. The bulkiness of the air-dried peat, which makes it expensive in handling and shipping, is the greatest objection to its more general use, and as early as 1853 experiments for the manufacture of pressed peat were carried out in England by Gwynne and later at Haspelmoor in Germany, by Exter. By this method the surface of the bog was harrowed and the peat spread out in thin layers to dry. When partially air-dried, the peat was brought to the briquetting plant where it passed through suitable sieves and was further dried by steam to 12–15% moisture content. The dried material was pressed in double acting excenter presses.

The results obtained were not very satisfactory and for many years the briquetting of peat was left untouched, until the success in the manufacture

\* Torfbriketter by Alf. Larson, Teknisk Tidsskrift, 1907.



of lignite briquettes again drew attention to this question. So far four peat briquetting plants constructed in the same manner as the lignite briquetting plants are or have been in operation.

These plants are as follows: One at Irinowka, near St. Petersburg, Russia; one at Langenberg, near Stettin, Germany; one at Ostrach, in Hohenzollern, Germany, each with one press, and one at Helenaveen, in Holland, with two presses. The plant at Helenaveen is at present closed down, and as far as can be learned none of these plants have been very successful from an economical point of view.

The manufacture of peat or lignite briquettes is as follows: The raw material is brought to the plant and dumped into a receptacle for an elevator which conveys it to a hopper on a rolling mill, see Fig. 145, where it is crushed to a coarse powder. The powder is passed over a sieve, allowing only the fine powder to go through. The coarser material is passed through another mill or disintegrator and again sieved as before. Any material still too coarse to

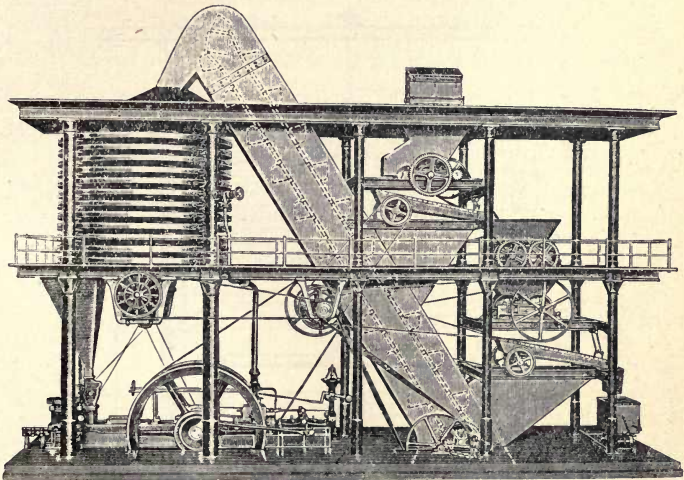


FIG. 145—Briquetting Plant by Zeitzer Eisengiesserei und Maschinenbau Actien Gesellschaft, Zeitz, Germany.

pass through the sieve is automatically transported to the boiler plant, which is generally supplied with step-grates. The fine material (smaller than 0.4 inches) is transported by means of an elevator to the drying apparatus, above which a certain amount of raw material is always stored in case of stoppages of the mills or disintegrators.

The content of moisture in the raw material is ascertained daily in order that the drying apparatus may be regulated accordingly.

The drying apparatus employed are of two kinds: steam plater drier and Schulz rotating driers, of which the former are the oldest. The construction of a steam plate drier is shown in Figs. 146-148. It consists of hollow cast iron plates, *n*, placed above each other, in which steam of 1.5-2.5 atmospheres pressure from the steam engines and briquetting presses is let in. The diameters of the plates are about 16.5 feet and their number from 20 to 32, depending on the contents of moisture in the material to be dried. In the center of the plates is placed a rotating shaft, *W*, provided with arms, *a*, carrying scrapers, *r*, which move the material from the center to the circumference on one plate and in the opposite direction on the following plate. The cylindrical spaces between the plates are covered with strips of sheet iron provided with openings, by means of which the condition of the material can be easily ascertained and air let in, which escapes on the opposite side through a half cylinder. The air let in carries away the damp air between the plates, which greatly assists the drying. Some of the rotating arms are provided

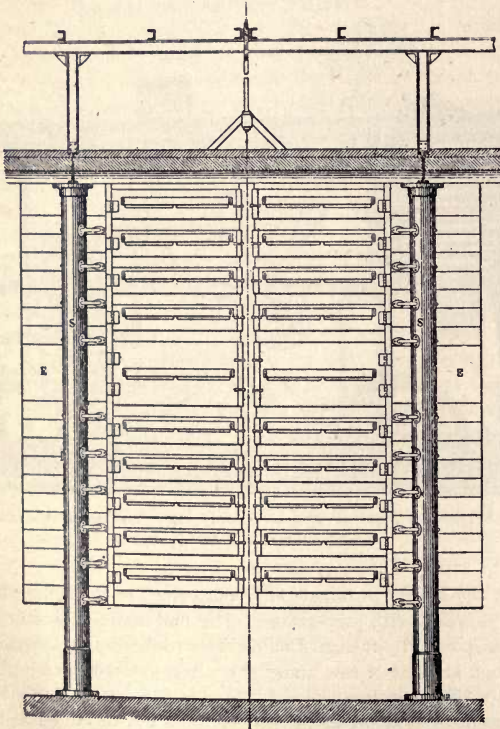


FIG. 146—Steam plate Drier (side view)

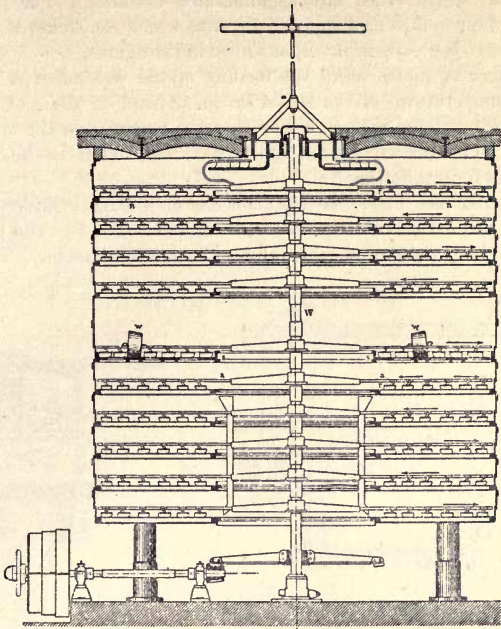


FIG. 147—Steam plate Drier (section).

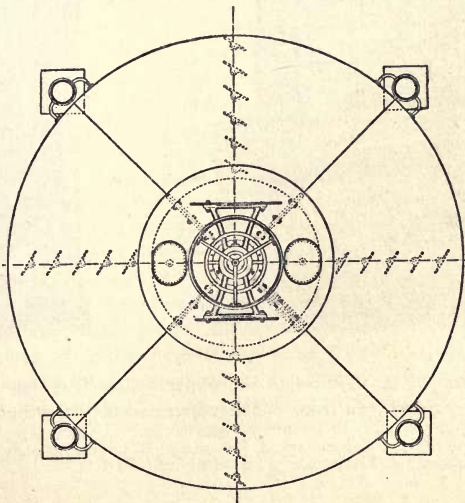


FIG. 148—Steam plate Drier (plan).

with rollers, w, which crush any agglomerated material. The plates are carried up by four hollow cast iron pillars, s, to which the steam is conveyed and distributed to the various plates, as shown in the figures.

The number of plates used, the feeding of the wet material and the pressure (or temperature) of the steam let in, depend on the moisture contained, and are regulated in such a way that the material on the lower plate has 12-18% moisture, which for lignite has been found to be the most suitable content for briquetting.\*

Schulz's drier, see Figs. 149-152, consists of a large cylinder of boiler plates with 7° inclination rotating on two trunnions. The two end plates are connected by a large number of tubes, about 4 inches in diameter. The steam

Fig. 149.

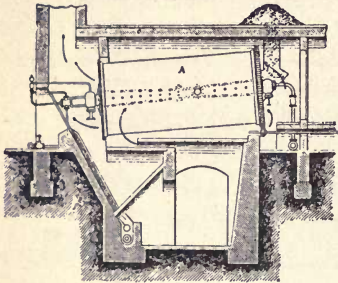


Fig. 150.

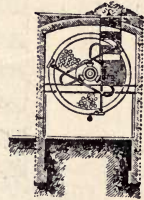


Fig. 151.

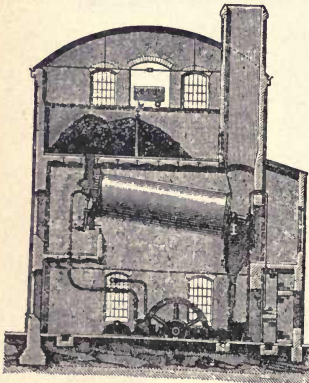
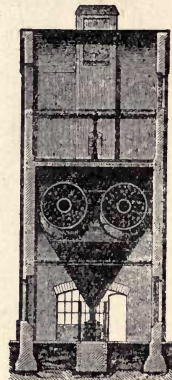


Fig. 152.



Schulz Drier.

used for drying is let in through the upper hollow trunnion and surrounds and heats the tubes. In front of the upper end of the cylinder is a feeding

\* According to G. v. Heidenstam, A. Larson and M. Ekenberg, perfectly dry peat can be briquetted above 100° Centigrade to first-class briquettes.

apparatus for the wet material, which runs slowly through the tubes. The feeding is regulated in such a manner that the material leaving the tubes has the required amount of moisture left. In order to facilitate the drying, a small amount of air is let in, which passing through the tubes in the same direction as the material to be dried, facilitates the expulsion of the moisture.

The new apparatus of this construction have cleats, see Fig. 153, in the tubes, which stir the material when the cylinder rotates bringing the different parts of same into contact with the hot walls and with the air. The efficiency is thereby increased some 20%.



FIG. 153—Tubes in Schulz Drier.

The condensed water is collected in receptacles placed at the lower end of the cylinder and by means of pipes (see Fig. 150) connected with the hollow lower trunnion conveyed back to the boilers.

Neither the steam plate nor the Schulz drier are covered to prevent radiation. The air, which is heated by the heat radiating through the walls, passes through the drier and facilitates the drying process. At the peat briquetting plant at Ostrach the air was preheated in an apparatus by the waste gases from the boilers, and the hot air was drawn through the tubes by means of a fan.

The Schulz drier is made in different sizes. The ones chiefly used for lignite have a diameter of 9.5 feet, length 23 feet and have 343 tubes with a heating surface of 7,668 square feet. The average production per 24 hours is about 52 tons dried material with 12-18% moisture, when the raw material contains about 50% moisture.

The steam plate drier permits of an easy regulation of the raw material put in. Samples can be conveniently taken at any place during the drying and the evaporation per unit weight of steam is larger than in the Schulz drier without cleats. The latter apparatus has less movable parts and needs, therefore, fewer repairs and in those provided with cleats the evaporation per unit weight of steam is at least as much as in the steam plate drier. They are, therefore, gradually replacing the latter.

A large experience has shown that in plants where superheated steam is used for the engines and the driers are provided with cleats, 3.34 lbs. of steam are required for the operation of the plant and for the evaporation of 2.2 lbs. moisture from the wet material.

During the drying of the material, a certain amount is always lost in the form of fine dust, which escapes through the chimney placed above each drying apparatus. This loss amounts to some 5% of the dried material. The chimneys are necessary on account of the explosiveness of the dust and the danger to the health of the workmen. The receptacle for the dried material must, therefore, be completely covered in and separated from the other parts of the plant.

The dried material is sometimes passed through a mill and a sieve in order to make it still finer and more homogeneous.

Different arrangements are used in order to decrease the loss caused by the dust, such as chambers where the dust can collect, washing it down with finely distributed water or steam, in which case the resulting material is pressed in filter presses and afterwards used as fuel.

The dried material is conveyed to a storeroom in the briquetting part of the plant by means of belt conveyors, screws or elevators. The most usual arrangement up to the present time has been to always have enough dried material stored in this room to last during 8-10 hours briquetting, in order to be able to run the presses continuously in case the drying apparatus should need to be stopped during a short time. The advantage is also gained hereby, that the material which is brought to the hopper of the press by a screw placed at the bottom of this receptacle is further mixed, and in the large receptacle gets time to cool down, so that the temperature in the press can be kept at about 90° centigrade. The objection to this large receptacle is that the fine material is liable to ignite and in modern plants it is therefore replaced by larger hoppers placed above the presses and by other arrangements. The material is then cooled in special *cooling apparatus*.

One of these is a plate apparatus consisting of a number of solid plates 13-16 feet in diameter, placed above each other and otherwise constructed in the same manner as the steam plate drier described, but without any steam heating. The objection to this apparatus is the large amount of dust produced, necessitating the installment of special apparatus to prevent or decrease this loss. Another apparatus which is better is a so-called shutter apparatus which consists of a number of horizontal sheet iron plates, with their inner ends bent in obtuse angles, placed in two vertical rows. The material descends slowly in thin layers and cannot get outside the apparatus. The room in which the apparatus is placed is well ventilated, but without any artificial draft. The material in both of these cases is cooled and water evaporated, which increases the efficiency of the plant. After the material is dried and cooled in this manner, it goes to the briquetting press.

The presses used in Europe are all of the same open tube construction and direct coupled to a steam engine\* as shown in Fig. 154.

The press and engine are built together in a strong frame and between the two is placed a strong crank shaft, provided with heavy fly-wheels and outside cranks, by means of which the motion of the cylinder piston is conveyed to his shaft. The center of the shaft is made with an eccentric sheave driving the press plunger, which is guided by a strong guide. The plunger is provided with an interchangeable end piece and runs in a die block made of strong cast iron. The die (see Fig. 155) consists of an open tube made of steel or special cast iron plates about 3 feet in length. The interior section of this tube forms the section of the briquettes. The tube has a slightly larger

\* Presses driven by belts or gear wheels have, at the experiments made in Europe, proved to be entirely unsuitable.

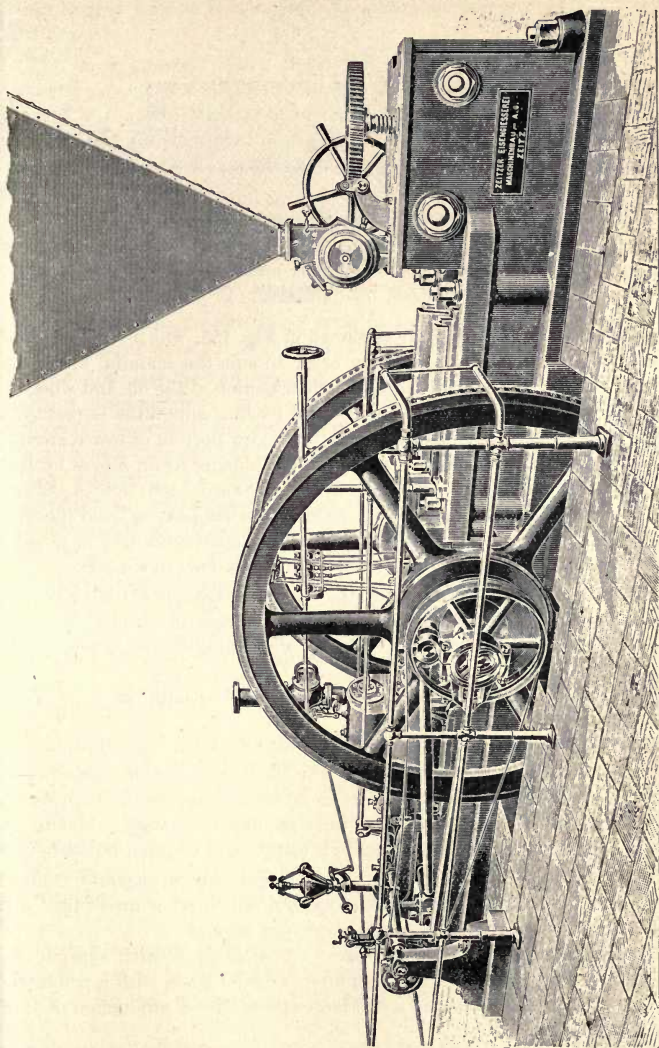


FIG. 154—Briquette Press for Lignite or Peat.

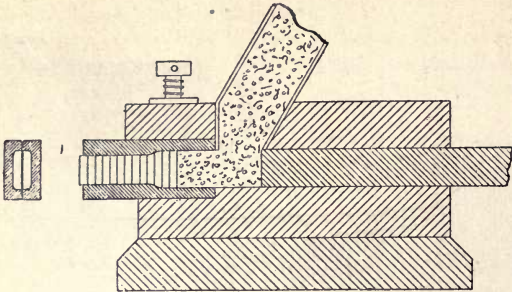


FIG. 155—Section of Briquette Press.

cross-section nearest the hopper, as shown in Fig. 155, which to some extent can be regulated during the work, in order to suit the material briquetted. The press plunger fits perfectly into the wider section of the die and when it is pressed forward the material fed in by the feeding apparatus is pressed to one briquette. During its backward motion a new portion of raw material is fed in and another briquette formed, when the plunger again moves forward. The briquettes previously made are moved forward each time a distance equal to the thickness of the new briquette, and when passing from the wider section of the die to the narrower section they are again submitted to pressure. The friction developed in the die constitutes the resistance in the press.

On account of the great friction the die plates are quickly worn out and must be removed two or three times a week and reground with emery wheels. The length of the stroke is 6.4-10 inches, depending on the material to be briquetted.

The pressure momentarily reaches 1,200-2,000 atmospheres or 17,064-28,440 lbs. per square inch.

Heat is developed through the pressure and friction and the die block must be cooled by water circulation. The block is therefore made hollow. When the press is started steam is let in to heat it up, but as soon as it is working the heat developed is more than required and water is let in and kept circulating so that the temperature is maintained at about 90°centigrade.

When briquetting lignite, the press plunger makes generally 100-120 strokes per minute, and in exceptional cases down to 80 or up to 130. The production is, therefore, 80-130 briquettes per minute.

The presses are built in three sizes:—A small press with a production of 16.5-22.0 tons briquettes per 24 hours; a larger press with a production of 33-44 tons per 24 hours, and a still larger press with a production of 44-55 tons per 24\*hours.

With peat it is safer not to count upon a larger production than 16.5, 33 and 44 tons for the respective sizes of the presses, and the number of briquettes per minute 80-100. Dried peat is not as heavy as lignite and



gives, therefore, lighter briquettes, and if the velocity is made greater than 100 strokes per minute it sometimes happens that the peat fed in is blown up in the hopper.

The large presses require about 100 indicated h.p., use high pressure steam and cut off at 50–60% of the stroke, and require 38.5 lbs. steam per indicated h.p. hour. The steam in the boiler is superheated to 350° centigrade and has 10 atmospheres pressure. The amount of steam required, if lower pressure and not superheated steam is used, may reach 59 lbs. per h.p. hour.

The boilers used are generally Cornwall boilers with large steam domes. At modern plants the pressure is 10 atmospheres, and the steam superheated to 380° centigrade. The steam engines for the presses, as well as for other purposes, work without condensation, on account of the exhaust steam of  $1\frac{1}{2}$ – $2\frac{1}{2}$  atmospheres pressure being used in the drying apparatus, in which also fresh steam reduced to 2 atmospheres pressure is sometimes used.

Assuming that the raw material contains such a percentage of moisture that it is necessary to have the exhaust steam of 2 atmospheres pressure, this pressure corresponds to a temperature of 121° centigrade, then there will be a difference of 21° for the evaporation of the moisture, which is quite sufficient. The steam in the drying apparatus is condensed to water under the same pressure, and this water is returned to the boilers (with about 110° C. temperature). The latent heat of the steam is utilised, and the heat economy is on the whole very good.\*

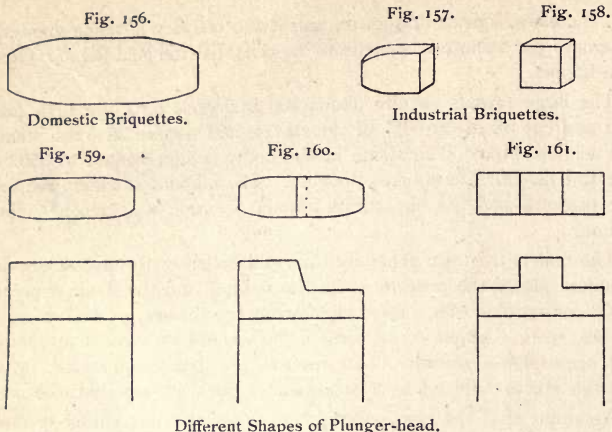
The briquettes leaving the press are pressed out in iron channels of the same cross-section as the briquettes and conveyed to storehouses or loaded direct on cars. These channels, of which several are generally used, are of considerable length, in order to give the briquettes sufficient time to cool. When the briquettes are piled up, small spaces are left between for air circulation and further cooling.

The briquettes are made in different shapes: domestic briquettes, see Fig. 156, and industrial briquettes, see Fig. 157, 158. The latter are only one-half or one-third as big as the former, but the same weight is produced in the same time and in the same press as the domestic briquettes, and depends only on the shape of the plunger head.

The shape of the plunger head used for pressing domestic briquettes is shown in Fig. 159, and those used for industrial briquettes in Figs. 160 and 161.

During the press work the mass as it comes from the die head consists of two or three parts; these stick together, due to the heat and pressure, but as soon as cooled, separate into the individual briquettes.

\* The briquette press requires per h.p. hour 17.5 kg. steam of 11 atmospheres pressure (=185° C.) which is superheated to 350° C. The steam contains, therefore, per kg.  $606.5 + 0.305 \times 185 + 0.48 (350 - 185) = 742$  calories and 17.5 kg. steam 12985 calories. A horse-power hour is equivalent to some 600 calories, and by the work in the press only about 5% of its heat is loosed.



The power required for a plant with one press is: for the press, 100 indicated h.p., and for the rest of the apparatus used, 50–60 h.p.

The cost of production per ton of lignite briquettes, when only one press is used, is 48–60 cents per ton, and when several presses are employed, 38–48 cents.

Including all expenses, except amortization of the plant, the cost of production is, on an average, between \$1.00 and \$1.40 per ton f.o.b. railway car. The selling price per ton lignite briquettes f.o.b. manufacturing plant is on an average \$2.20 per ton.

Amongst the firms which manufacture briquetting machinery for peat and lignite the most important are: Zeitzer Eisengiesserei und Maschinenbau, Actien Gesellschaft zu Zeitz and Maschinenfabrik Buckau Actien, Gesellschaft zu Magdeburg, both in Germany.

The construction of a *briquetting plant*\* with one press and one steam plate drier is shown in Fig. 162, and a similar plant with a Schulz drier in Fig. 163.

In the plant shown in Fig. 162 the partly air-dried peat (raw material) is brought by means of an elevator or aerial tramway to the hopper A of the mill B. The crushed material passes on to the sieve C. The sufficiently fine material passing through the sieve is conveyed through shoot Z to the elevator G. The balance goes to hopper D and through the disintegrator E, from which it is conveyed through shoot F to the same elevator G. The elevator carries it up to the rotating sieve I, from where the fine material is brought by the conveyor K to the room N above the steam plate drier O. The material too coarse to pass through the sieve I is conveyed by shoot L to cars M or some other conveyors, and generally used as fuel under the boilers. After passing through the drier, the dried material is conveyed

\* By Zeitzer Eisengiesserei und Maschinenbau A. G.

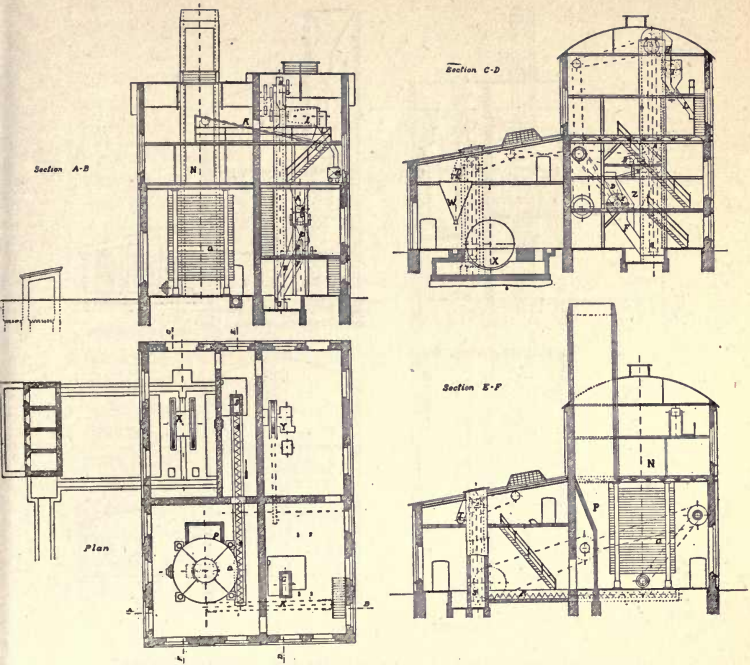


FIG. 162—Peat Briquetting Plant with One Press and Steamplate Drier.

to the elevator S by screw conveyor R, which carries it up and dumps it in hopper T to the screw conveyor U. The distance which the dried material has to travel is made as long as possible in order to give it time to cool before entering the hopper W to the press X. The drier is provided with a large chimney P, which carries away the fine dust.

In the plant shown in Fig. 163 the raw material is brought to the hopper A of the mill B. The fine material passes through sieve C into shoot D and then to the elevator H. The balance passes through hopper E to the disintegrator F, and from there through shoot G to elevator H. The elevator carries the material to the rotating sieve K, from where the fine material is conveyed to hopper N of the drier O by conveyor M. The coarse material is conveyed by shoot L to cars and used as fuel. After passing through the drier the dried material is conveyed by screw conveyor P, to a cooling apparatus R, and from there by another screw conveyor to the hopper T and into the press U.

The chimney to the drier is provided with partitions in order to collect the dust and utilize it for fuel purposes.

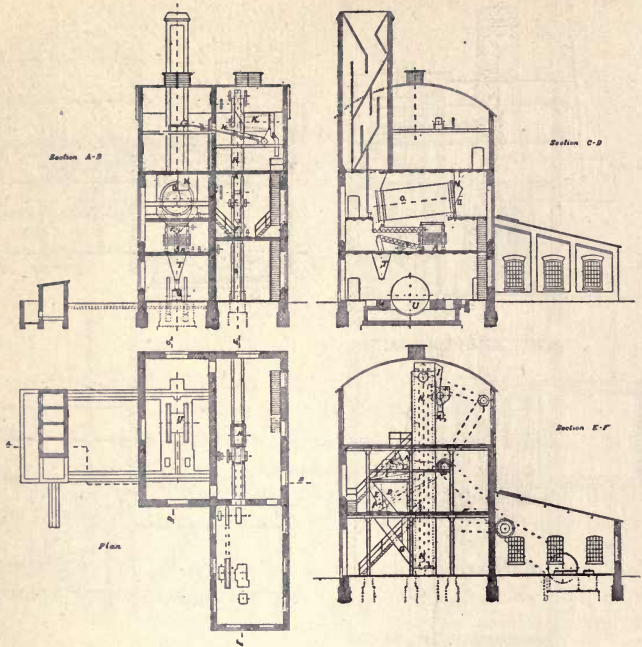


FIG. 163—Peat Briquetting Plant with One Press and Schulz Drier.

According to Zeitzer Actien-Gesellschaft, the daily production in 24 hours of such a plant, using raw lignite, with a content of moisture of 50–55%, is 55 tons per 24 hours, or a yearly production of 16,500 tons lignite briquettes.

The machinery and apparatus necessary for a plant with one press and steam plate drier, and the cost of the same f.o.b. Zeitz, are given below:

	Marks.
2 boilers 33.3 feet in length x 6.6 feet in diameter, with 860.8 sq. feet heating surface, and tested for 11 atmospheres pressure . . . . .	14,820
2 gages and accessories for the boilers . . . . .	4,100
2 apparatus for superheating the steam . . . . .	3,700
2 Duplex steam pumps . . . . .	2,400
1 " pump . . . . .	1,050
1 tank for hot water . . . . .	765
1 " " " . . . . .	2,000
1 tank for cooling water . . . . .	475
1 complete conveying apparatus and crusher . . . . .	2,200

1 sieve . . . . .	1,375
1 disintegrator . . . . .	3,850
1 elevator . . . . .	2,300
1 rotating sieve . . . . .	1,350
Shoots . . . . .	1,380
1 conveyor . . . . .	1,075
Iron constructions . . . . .	1,200
1 steam plate drier with 26 plates 16.6 feet in diameter . . . . .	38,500
1 dust collector . . . . .	1,200
1 chimney with dampers, etc., for the drier . . . . .	360
Pipes for ventillation, etc. . . . .	570
1 screw conveyor for the dried material . . . . .	682.50
1 elevator for the dried material . . . . .	1,650
1 screw conveyor to the press . . . . .	325
1 briquette press, with hopper, etc., and steam engine . . . . .	19,500
1 railing around the press . . . . .	350
1 water trap . . . . .	60
4 steel screws for the press . . . . .	400
1 large press block . . . . .	475
Reserve parts for the press . . . . .	1,630
500 feet channels for the briquettes . . . . .	1,200
1 injector for boiler, etc. . . . .	1,500
1 steam engine complete . . . . .	7,000
Shafting, pulleys, etc., without belting . . . . .	4,800
Safety appliances . . . . .	660
Piping, valves, etc. . . . .	13,000
2 oil separators, with accessories . . . . .	1,350
Supports and columns for pipes, etc. . . . .	450
Covers for channels, etc. . . . .	525
Iron constructions for the plant . . . . .	14,500
Sheet iron, cast iron, doors, stairs, etc. . . . .	8,568
	<hr/>
Total marks . . . . .	163,295.50
Iron construction, etc., for boiler house . . . . .	6,420.00
	<hr/>
Total marks . . . . .	169,715.50
	<hr/>

To this must be added freight, duty, cost of erection and cost of brick works and miscellaneous material, which will probably bring the cost up to a total of 225,000–250,000 marks, or 54,000–60,000 dollars.

PEAT BRIQUETTES.—The successful manufacture of peat briquettes is dependent on the following factors:

- (1) The nature of the bog.
- (2) The price of the raw material.
- (3) The amount of steam or fuel required for drying.
- (4) Labour costs.
- (5) The cost of the plant.
- (6) The cost of manufacture.
- (7) Competition with other fuels.

(1) *The nature of the bog.*—A briquetting plant is, as has previously been shown, an expensive undertaking, even if built with only one press.\* The bog where the plant is to be located must, therefore, be of such extent that raw material for at least 20 years can be obtained. The peat must be well humified and heavy, give at least 330–340 lbs. air-dried peat (25% moisture) per cubic yard and not be too high in ash. The peat briquetting plants so far erected all use cut peat as raw material for the briquette manufacture, since it is more porous and easier to crush and disintegrate than the tougher machine peat. The peat is air-dried down to 40–50% moisture before being brought to the briquetting plant. To dry it more before crushing is not advisable on account of the large amount of dust which then is produced, endangering the health of the workmen, causing a greater loss of material, and in certain cases giving rise to explosions.

A plant with one large press has a yearly capacity of 13,000–13,500 tons briquettes with about 15% moisture. This production would require 90,000–93,000 cubic yards of raw peat or about 10 acres of a bog 6 feet in depth after being drained and settled. The fuel required in the plant for the boilers is additional.

The bog must, therefore, have sufficient area to provide enough drying field and, as a rule, the same field can be used three times during the season. A well laid out plant should have a year's supply of peat on hand, in order to be independent of unfavourable weather conditions. The peat should also be protected from freezing, since when once frozen it is hard or impossible to briquette.

(2) *The price of the raw material.*—The manufacture of cut peat on a large scale is not likely to prove a suitable method in Canada, on account of the large number of workmen required during the short working season, and in cases where this method is used the different layers of the bog should be of uniform quality. Such bogs are undoubtedly few, and machined peat, when the different layers of the bog are mixed and a uniform product obtained, is probably quite as suitable. Assuming the most favourable case: that a bog containing peat of suitable quality and comparatively free from roots and tree stumps can be had, and that this bog is worked with mechanical excavators and peat machines run with electric motors, such as O. Strenge's machines.

\* The smaller the plant is, i.e., the fewer presses are used, the larger is the cost of production per ton product.

The amount of dry peat substance required for a plant with one press and a capacity of 44 tons briquettes per 24 hours, is about 18,000 tons per year.

O. Strenge's peat machine handles with 14 men about 1,000 cub. yards of raw peat per day of 10 hours, which is equivalent to 110 tons dry peat substance, when 1 cubic yard of raw peat is assumed to give only 220 lbs. peat substance. The peat needs only to be air-dried down to 50% moisture and the working season can undoubtedly be extended to 100 days, in which case such a machine would produce 11,000 tons dry peat substance per season. With two machines, therefore, more than the required amount of raw material can be produced.

The cost of the peat is calculated as follows:

14 men at \$1.50 per day at the peat plant . . . . .	\$21.00
Fuel for a 45 h.p. motor,* oil, etc. . . . .	3.00
	<hr/>
Total . . . . .	24.00

110 tons dry peat substance is equal to 220 tons with 50% moisture, making the cost per ton peat with 50% moisture . . . . . \$ 0.11

#### DRYING WORK, ETC.

Turning and piling at 5c. per 1,000 peat bricks.

These 1,000 bricks with 25% moisture (weight about 1.7 lbs. per piece) contain 1,275 lbs. dry peat substance. The cost per ton peat, with 50% moisture is therefore. . . . . 0.04

Foremen and administration, \$2,000 per year for 40,000 tons, per ton with 50% moisture . . . . . 0.05

Maintenance of drains, levelling, repairs, etc., \$3,000 per year, per ton with 50% moisture. . . . . 0.08

Amortization of the peat plant with tracks, cars, etc., and maintenance 8% of the cost (about \$13,500) or \$1,080, per ton peat with 50% moisture (22,000 tons). . . . . 0.05

Stacking and transport to the plant, per ton. . . . . 0.20

Amortization of the bog, which drained and levelled is assumed to cost \$50 per acre. About 20 acres of the bog is worked out yearly, representing a capital of \$1,000, per ton peat with 50% moisture 0.03

One year's interest on the peat stored, etc., per ton. . . . . 0.04

The total cost of one ton peat with 50% moisture is, in this case, at the briquetting plant . . . . . \$ 0.60

\* With a central power station and electric motors, the steam consumption is at the most 22 lbs. per h.p. hour, and per 10 hours and with 3 lbs. steam per 1 lb. fuel, the fuel consumption is  $\frac{22 \times 45 \times 10}{3} = 1.65$  tons per day. With a price of \$1.50 per ton fuel the cost is \$2.47 per day.

Each ton of peat briquettes with 15% moisture requires 1,700 lbs. dry peat substance to which must be added the loss caused through the escaping fine dust, amounting to some 5% or 85 lbs. making a total of 1,785 lbs. or in round numbers 1,800 lbs. The raw material required with 50% moisture is therefore 3,600 lbs., and the water to be evaporated per ton briquettes is 1,600 lbs.

(3.) *Steam or fuel consumption.*—Extensive experiments have shown that with a Schulz drier provided with cleats, and when superheated steam is used for the engines, the amount of steam required for the running of the plant and the drying of the peat is 1.52 lbs. for 1 lb. evaporated water. The amount of steam required per ton briquettes is in this case  $1.52 \times 1,600 = 2,432$  lbs. The amount of steam generated per 1 lb. peat fuel with 50% moisture can now be calculated. Assuming that the peat when perfectly dry and free from ash has a calorific value of 5,600 calories per kg., a content of hydrogen of 5.8% and a content of ash in dried state of 4%. With 50% moisture, it then contains 2% ash, 48% organic substance and has a calorific value of  $5,600 \times 0.48 - (54 \times 5.8 \times 0.48 + 600 \times 0.5)^* = 2,238$  calories per kg., or in round numbers 2,200 calories.

With 10 atmospheres pressure in the boiler corresponding to a temperature of 185° centigrade, superheated steam of 385° C. (350° degrees in the cylinders), 60% efficiency of the fuel and feed water of 110° C., the steam produced per kg. peat fuel is as follows:

1 kg. steam of 185° C. contains  $606 + 0.305 \times 185 = 663$  calories

Through the super-heating of the steam is added

$0.48 \dagger \times 200 \dots \dots \dots 96$  “

759 “

The feed water of 110°C contains  $\dots \dots \dots 110$  “

The amount of heat required per kg. steam is therefore. 649 “

With 60% efficiency of the fuel, 1 kg. peat with 50% moisture then produces 2 kg. steam (or 1 lb. peat, 2 lbs. steam).

2,432 lbs. steam were required per ton briquettes, which corresponds to 1,216 lbs. peat fuel with 50% moisture.

The amount of raw material required per 1,000 tons briquettes is consequently:

For briquetting 1,800 tons at 60c. per ton  $\dots \dots \dots$  \$1,080

For fuel 608 tons at 60c. per ton  $\dots \dots \dots$  365

Total  $\dots \dots \dots$  \$1,445

\*  $W = C \times 8080 + (H - \frac{O}{8}) 34000 - (9H + w) 600$ . In the above formula  $5600 \times 0.48 = C \times 8080 + (H - \frac{O}{8}) 34000$  and  $54 \times 5.8 \times 0.48 + 600 \times 0.5 = (9H + w) 600$ ; H=weight of hydrogen, w=weight of water contained in the fuel.

† The specific heat of steam=0.48.



(4.) *Labour cost.*—Experience in the lignite briquetting plants has shown, that this cost per 10 tons briquettes is, including all expenditure, in plants with; 1 press, \$4.54; 2 presses, \$4.00; 3 presses, \$3.64.; 4 presses, \$3.10; 5 presses, \$2.73; 6 presses, \$2.23.

In the case of a plant with one press the labour cost per ton of 2,000 lbs. should therefore amount to 46 cents, but as the wages in Canada are higher, this cost is assumed to be 60 cents per ton.

(5.) *Cost of Plant.*—The cost of a plant with one press has previously been given in detail, and amounted to \$54,000–\$60,000; but in order to be on the safe side, the cost of the plant with sheds and everything complete is here assumed to be \$75,000, and the yearly production 13,000 tons briquettes.

The cost of the plant should be amortized in 20 years, or with 5% per year, and the plant maintained with 3%, total 8% per year = \$6,000, which makes 46 cents per ton briquettes.

The amortization of the peat plant and bog is already included in the cost of the peat.

(6.) *Total cost of manufacture.*—Per one ton briquettes.

1.8 tons peat for briquetting, at 60c. per ton . . . .	\$1.08
0.608 tons peat for fuel, at 60c. per ton . . . . .	0.34
Briquetting costs . . . . .	0.60
Amortization and maintenance . . . . .	0.46
	<hr/>
Total . . . . .	\$2.48

or, in round numbers, \$2.50 per ton briquettes.

The capital required is:

Bog of 400 acres at \$50 per acre . . . . .	\$20,000
2 peat machines with necessary appliances, at \$13,500 . . . . .	27,000
Briquetting plant . . . . .	75,000
Working capital . . . . .	13,000
	<hr/>
Total . . . . .	\$135,000

This capital should bear 6% interest to the shareholders, and for sinking funds, etc., about 4%, a total of 10%, amounting to \$13,500, or about \$1.00 per ton briquettes. The cost of the briquettes f.o.b. the plant should therefore be \$3.50 per ton.

(7.) *Competition with other fuels.*—The effective fuel value of common machine peat with 25% moisture is, on an average, 6,606 B.T.U. per lb., and that of peat briquettes with 15% moisture made from the same peat, 7,560 B.T.U. per lb. The cost of the latter, if only the fuel value is taken into consideration, should therefore be only about 15% higher in order to compete with machine peat. It has previously been shown that the cost of

machine peat with 25% moisture ought not to exceed \$2.00 per ton, and in such case the same fuel value is obtained about 50% cheaper with machine peat than with peat briquettes. For industrial purposes peat briquettes, consequently, cannot compete with machine peat.

The value of a fuel depends not only on its calorific value, but also on the way in which it burns, the nature of the ash or slag, and the ease with which it ignites (the latter especially for domestic purposes). Machine peat ignites sooner and burns better than the briquettes, which have a greater tendency to fall to pieces. The briquettes occupy a smaller volume for the same weight, have a nicer shape, and are less liable to absorb moisture than the machine peat. The weight of one cubic yard of machine peat is, on an average, 577 lbs., and that of one cubic yard of briquettes 1,320–1,485 and, in exceptional cases, 1,650 lbs. The transportation of briquettes is therefore cheaper than that of machine peat.

In comparison with coal, 1.6 tons briquettes are equal in fuel value to 1 ton of ordinary steam coal, and in order to compete with coal, the price of the latter should be about \$5.60 per ton, which price, so far, is reached only in exceptional cases.

In comparison with wood, the figures are as follows:

Wood with 30% moisture has a calorific value of 5,040 B.T.U. per lb. and in order to compete with the peat briquettes, the price of one ton wood (sawed and cut) should be  $\frac{5,040}{7,560} \times \$3.50 = \$2.33$ .

One cubic foot of soft wood weighs about 23 lbs., and one cub. foot of hard wood about 30 lbs.

One cord soft wood (128 cub. feet) should therefore cost \$3.42.

One cord hard wood " " " " \$4.47

in order to compete with briquettes at \$3.50 per ton.

From what has been said it is evident that the economical results of briquetting peat which is not carbonized are doubtful. The cost of manufacture given here for a plant with only one press are possibly rather high, and could probably be somewhat decreased, but before a briquetting plant is started, the various local conditions should be carefully investigated.

**CANADIAN PEAT BRIQUETTE MANUFACTURE.**—Most of the attempts made in Canada to manufacture peat fuel have been the manufacture of peat briquettes. The methods used and the machinery employed are fully described in Bulletin No. 5 of the Bureau of Mines\* of Ontario, from which the following is mostly obtained:

The two most interesting plants were† those at Welland and Beaverton.

*The Welland plant.*—The method here used to obtain the raw material for the briquetting plant was to harrow the surface of the bog and expose a thin covering of peat to the action of the wind and sun.‡ By

\* Now the Department of Lands and Mines, Toronto, Ont.

† At present not working.

‡ The same method was used long before in Bavaria and abandoned.

harrowing the ground twice on each occasion, a layer of peat from  $1\frac{1}{2}$  to 2 inches deep is exposed. When dried down to a water content of about 45% the peat was scraped by hand over to the tramway, loaded into cars and brought to the briquetting plant. Under the best conditions, bright sun, high temperature and strong wind, a layer of harrowed peat from 1 to  $1\frac{1}{2}$  inches deep will dry from 85% to 45% moisture in about  $2\frac{1}{2}$  hours.

The air-dried peat was first screened, then put through a drier and later disintegrated. The drier used at Welland is known as the Simpson drier. It consists (see Fig. 164) of two parallel revolving cylinders 30 feet long,

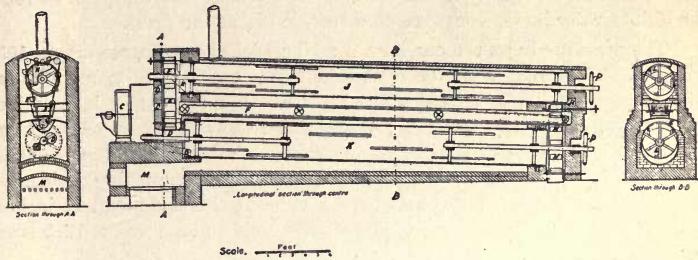


FIG. 164—The Simpson Drier.

C. Exhaust fan for water vapours. D. Passages connecting fan and cylinders. E. Elevator from conveyor to top cylinder. F. Conveyor compartment. G. Feed pipe. H. Feed chute to top cylinder from elevator. J. Upper cylinder. K. Lower cylinder. L. Angle iron lifters. M. Fire box. N. Elevator from lower cylinder to conveyor. P. Driving chain, sprocket wheels. R. Discharge pipe.

one placed above the other, made of  $\frac{3}{8}$ -inch sheet iron. Inside the cylinders are iron lifters for stirring the peat more effectually as the cylinders revolve. The space between the upper and lower cylinders is occupied by a conveyor pan, forming a third compartment. The peat first passes through the lower cylinder, then through the intervening compartment, and finally through the upper cylinder, from which it is discharged into a chute leading to the breaker or disintegrator. The combustion gases from the fire-box in front of the drier never come into actual contact with the peat, passing first around and along the lower cylinder and second compartment, and thence into the chamber containing the upper cylinder, the peat being heated entirely by radiation. On top of the fire-box is placed an exhaust fan, which draws away the water vapours given off by the drying peat. The upper cylinder makes three revolutions per minute, and the lower nine, a charge of peat occupying 20 minutes in passing through the drier from one end to the other. The mechanism is operated by sprocket wheels and chains.

Three tests to determine the efficiency of the Simpson drier were made, one in the autumn of 1901 and the other two in May, 1902. In the first test 3,006 lbs. peat containing 42.64% water were reduced to 2,280 lbs. containing 24.38% water, with a consumption of 128 lbs. wood (black ash) as fuel. Time, 2 hours 37 minutes; average temperature of drier 300° Fahr.

In the second test, 2,116 lbs. peat containing 46.38% water were reduced in 3 hours and 32 minutes to 1,451 lbs. containing 17.90% water, and in the third test, 2,752 lbs. peat with a water content of 54.59% were dried down in 2 hours and 20 minutes to 1,925 lbs. containing 25.96% water. A rather damp mixture of air-dried roots from the peat bog and screenings of sticks and moss from the air-dried peat was used as fuel in the second test, and in the third only roots were used.

These experiments prove the inefficiency of this drier and its small capacity. After passing the drier, the peat was conveyed to a disintegrator, the object being to promote further evaporation and cool the peat. From the disintegrator it was conveyed to a storage bin at the press.

The press used was the one known as the Dickson press, see Figs. 165 and 166. This press is of the open-tube type, and works in accordance with the German lignite presses. The interior section of the tube is the same all through, unlike the German presses, and results in looser and lighter briquettes. The construction is, however, much weaker, and the punches are driven by belt and gear wheels, which probably are the main deficiencies of this press. The briquettes made are of cylindrical shape about  $2\frac{1}{2}$  inches in diam. The capacity of such a double press was, on an average, 17.5 tons per day.

The workable depth of the bog was only about 3 feet, and for some years the plant has been closed down.

*The Beaverton plant.*—The methods and machinery used at this plant for the working of the bog, as well as for the subsequent treatment of the peat, are invented by Mr. A. Dobson, of Beaverton.

The bog is about  $2\frac{1}{2}$  feet in depth, well drained, free from roots and stumps and comparatively solid. The peat is dug out by a mechanical and electrically driven digger, which travels slowly up and down one or both sides of the area under removal, the excavating device working in the side or wall of the ditch. It consists of a platform 7 feet wide by 10 feet long, mounted on 4 wood faced wheels, the front pair being the drivers and measuring 33 inches in diameter and 18 inches face, and the rear wheels being 22 inches in diameter and 18 inches face. A 10 h.p. electric motor operates by belting and gear wheels all the machinery, and at the same time propels the carriage forward at the desired speed. Overhanging the ditch on the right hand side is the combined excavating and elevating mechanism which is free to swing in a vertical plane about the upper sprocket wheel shaft, and may be raised or lowered according to the depth of cut to be made, the maximum depth being 4 feet. It consists of an endless chain which travels down the outside and up the inside of the elevator box, and is set alternately with a row of cutting teeth and a sharp edged plate. It serves the double purpose of scraping off a thin slice of peat and elevating it to a conveyor running across the front of the carriage. At the opposite side the distributor, a partially hooded paddle wheel revolving at a high velocity, catches the stream of fragments and showers them over the surface of the bog to a distance of 30 to 50 feet, or as far as

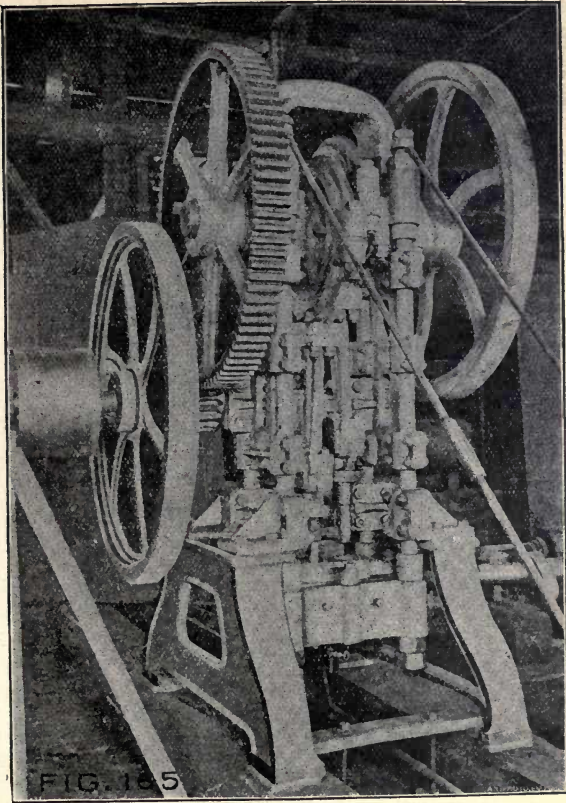


FIG. 165—The Dickson Peat Briquetting Press.

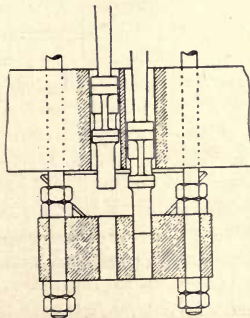


FIG. 166—Die Block to the Dickson Peat Press.

the tramway running down the center of the section, which the excavator is working. Each such shower forms a deposit about  $\frac{1}{2}$  an inch thick, consisting of finely divided fragments which are in excellent condition to be dried by wind and sun. The machine travels at the rate of 3 to 3.5 feet per minute. The workable depth of the Beaverton bog being 2.2 to 2.5 feet, the quantity of peat handled by the excavator is 7.5 cubic feet per minute, or 4,500 cubic feet per day of 10 hours. A cubic foot of peat in the bog weighs 56 lbs., consequently the machine raises 126 tons of wet peat per day, equivalent to 22 tons of finished peat containing 15% water.

A later excavator constructed by Dobson is shown in Fig. 167.

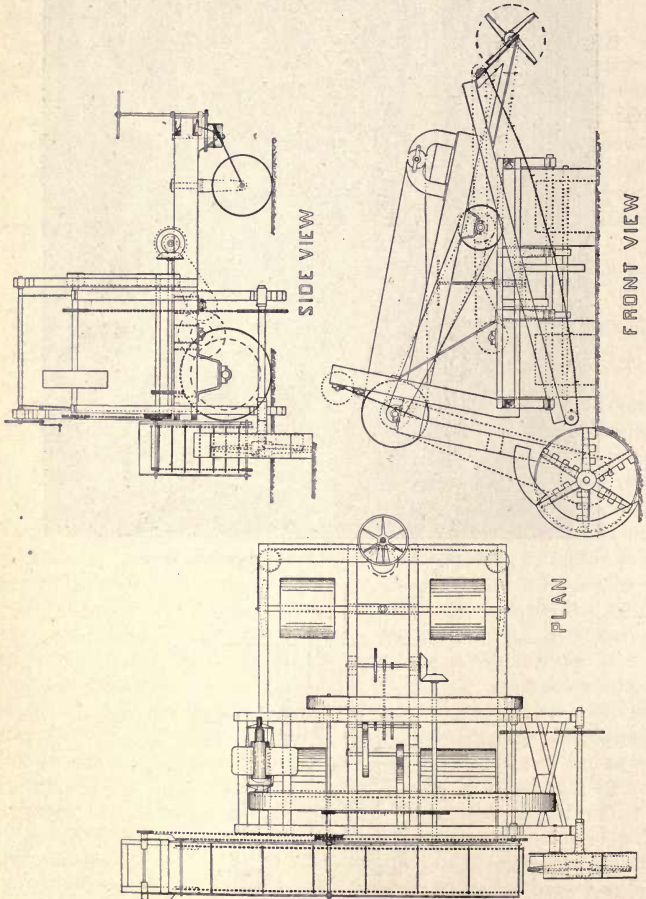


FIG. 167—The Dobson Peat Excavator.

Heavily insulated transmission wires trail over the bog behind the carriage from a central point in the field, and convey the electric current to the motor.

Scraping and raking the peat, as formerly done, began as soon as the uppermost layer became sufficiently dry. Two men, each with a wooden scraper about 4 feet wide in the blade, draw the layer of dried peat from  $\frac{1}{2}$  an inch to an inch in depth to the side of the tramway, and a third man following close behind, drags after him a wide, long-toothed rake, thus loosening the next layer and putting it in condition to be dried.

Later, Mr. Dobson invented a mechanical "scraping device" which does the work of these men.

The dried peat is loaded into electric tram cars, fitted with bottom dump gates, which hold the equivalent of one ton finished peat. The car is driven by a 4 h.p. electric motor, taking power from the generator through a pair of trolleys running on wires beneath the car and beside the rails. One man loads and operates the car. The track leads to an elevated trestle at the works, where the load may be deposited in the stack pile, in the bins, or in the disintegrator hopper, as may be required.

The air-dried peat is brought to a disintegrator, where it is subjected to a fierce hail of blows in order to reduce the size of the fragments, and destroy the cells of the peat fibres, thus permitting the remaining moisture to be more readily liberated in the drier. The machine consists of a circular sheet iron box encasing a horizontal shaft from which project cast iron arms about 1 foot in length. Through the ends of these and parallel to the shaft run iron rods each suspending a row of knob-like cast steel fingers 4 inches long, and free to swing about the rods. The shaft makes 400 revolutions per minute and the steel fingers flying out radially dash the peat fragments against a semi-circular grizzly set close beneath. Through the  $\frac{1}{8}$  inch spaces of this grating, the peat drops as a mixture of fine particles and dust, damp to the touch. The disintegrator itself requires no special attention, being looked after by the drier attendant; but for the greater part of the time, a man must be employed to shovel the air-dried peat into the conveyor leading from the storage bins or stack piles. From the bottom of the disintegrator a conveyor carries the peat to the hopper over the drier into the cylinder of which a regular feed is maintained.

The Dobson drier, see Fig. 168, consists of a revolving cylinder 30 feet long and 3 feet in diameter, made of  $\frac{3}{8}$  inch sheet iron plates, and set with a pitch of 14 inches in its length. The cylinder is placed inside a rectangular brick casing with a fire-box at the end. The shafting resting on bearings outside the brick-work extends 12 feet into each end of the cylinder supporting the latter by cast iron arms. Sets of six 3 by 3 inch angle irons, five feet long, are equally spaced around the interior of the cylinder, each angle raised by pins 3 inches from the surface, and each set advancing on the preceding one through a small angle of revolution to break the ends. The space between the cylinder and brick-work allows of unobstructed circulation of flames and

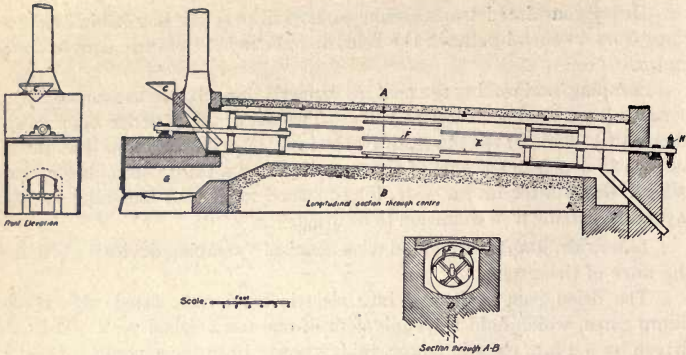


FIG. 168—The Dobson Drier.

C. Feed hopper. D. Discharge chute. E. Revolving cylinder. F. Angle iron lifters. G. Fire box. H. Driving chain, sprocket wheel.

gases around the exterior, from front to rear. The cylinder revolves by chain gear, at the fixed speed of  $1\frac{1}{2}$  revolutions per minute, at which rate a charge of peat will pass through it in 20 minutes.

The drier was under observation for test purposes during part of a day and the results obtained, calculated per day of 10 hours, gave: Weight of air-dried peat charged into drier 29,300 lbs. containing 34.21% water; weight of peat discharged from drier, 23,000 lbs. containing 16.61% water; weight of water evaporated 6,300 lbs. Blocks of crude air-dried peat, containing 34% water, were used as fuel at the rate of 3,145 lbs. per day.

The discharge pipe from the drier empties into the shoe of an elevator which carries the dried peat into a large galvanized iron hopper or bin interposed between the drier and the briquetting press.

The press used is also constructed by Mr. Dobson, and is a resistance block press, see Figs. 169, 170. In the Dobson press, friction is almost entirely eliminated, each die previous to being re-charged being oiled to prevent friction of the peat against the die wall in the subsequent expulsion of the briquette. The large number of dies employed for each punch keeps the temperature low. The briquette is allowed to remain in the die in which it is formed for one cycle of the system (about 6 seconds) and is then subjected to another compression by a second briquette, being formed on top of it. Immediately after this it is expelled and the second block takes its place. There are two punches in each machine, and to each punch a die block containing eight snugly fitting dies. The dies are heavier in the lower end where the compression takes place. The base block against which the briquettes are formed, remains rigid, unless for any reason the strain exceeds the working pressure, when a set of spiral steel springs, on which the block rests, takes up the excess pressure and prevents any breakage.

The down thrust of the punches is imparted by two heavy eccentrics faced with roller bearings, and with each stroke of the punch, the die block is turned



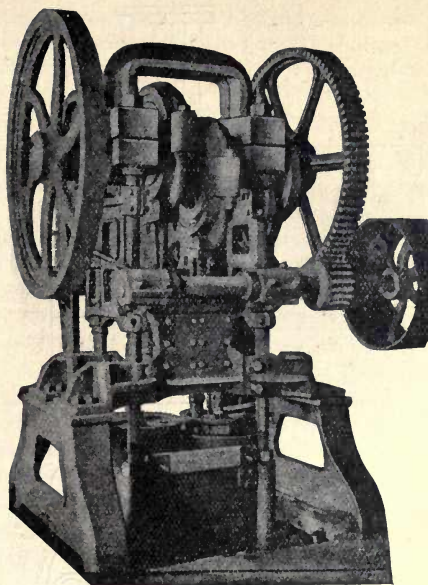


FIG. 169—The Dobson Peat Briquetting Press.

through one-eighth of a revolution. Working in the next die to the compressing punch is the releasing punch which expels the finished briquette, while the third receives an oil swab which coats the inside of the die with a film of crude petroleum, to lessen the friction and facilitate the expulsion of the briquette. The two punch systems of the press act reciprocally, a stroke being delivered at every half revolution of the eccentric shaft. With each down stroke the compressing punch forms a briquette on top of the one previously made in the same die, the discharging punch expels from the next die the bottom briquette, and the third die receives its coating of oil from the oil swab. Power is transmitted through belting to a pulley on the pinion shaft and thence by a 5 foot gear wheel operating the eccentric shaft. The machine is steadied by a heavy fly-wheel on each of these two shafts, and runs quietly and with little vibration. It makes 50 or 51 revolution per minute, producing 100 or 102 briquettes. Twenty-five briquettes weigh about 10 lbs., consequently the output of the press in 10 hours is about  $12\frac{1}{2}$  tons finished fuel.

The power required to operate the Beaverton plant was 40 h.p., distributed as follows:—

Briquetting press and elevator. . . . .	13 h.p.
Tram car . . . . .	4 "
Excavator. . . . .	8 "
Drier, disintegrator, conveyors, etc. . . . .	15 "

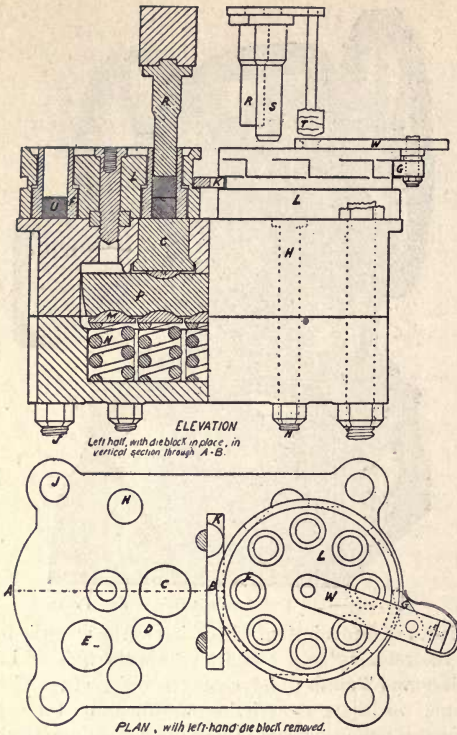


FIG. 170—Die Block and Bed to the Dobson Press.

C. Resistance block. D. Briquette discharge hole. E. Hole for removal of dies, ordinarily plugged. F. Dies. G. Ratchet. H. Four clamping bolts for the bed. J. Four tie rods supporting the whole. K. Hold-down bar for die blocks. L. Die blocks. M. Spherical buttons. N. Springs. P. One bar between resistance block and springs. R. Punch. S. Expelling punch. T. Oil swab. U. Peat Briquettes. W. Reciprocating lever.

The main objections to the methods and machinery used at Beaverton are:—That during continued rainy weather the work on the bog is interrupted, and where a large production is required the excavator or excavators have to cover a very large area. In a bog containing a greater number of roots and stumps, the work of the excavators is probably less satisfactory, and the surface of the bog requires a very careful levelling, which increases the cost. The drier has a comparatively small capacity, and explosions are liable to occur. The press is operated by belt and gear wheel, which are, in most cases, liable to break, and the pressure on the briquettes is less than in the open tube type. Regarding the cost of production, no reliable figures are obtainable.

Besides the Beaverton plant, Dobson plants were started at Fort Francis, Ont., and at Caledonia Springs, near Ottawa. The former was burnt down before commencing operations and not rebuilt, and the latter have not been in continuous operation so far.

A process similar to the one invented by Dobson is employed by Dr. J. McWilliam at a bog near London, Ont.

**MANUFACTURE OF BRIQUETTES WITHOUT AIR-DRYING THE PEAT.**—The dependence on favourable weather condition for air-drying the peat, the short season during which the bog can be worked and the trouble of obtaining the necessary number of workmen for only a few months during the year, are the strongest objections to the methods of air-drying the peat. Numerous methods have therefore been introduced from time to time, where artificial means have been tried for the removal of the moisture in the raw peat.

*Drying by pressure.*—Amongst these methods can be mentioned the experiments carried out by the Düsseldorf Eisenwerk and other firms. The raw peat was then subjected to heavy pressure in strong hydraulic presses, but the product obtained still contained some 65–70% moisture, which is too high for subsequent drying by heat. The removal of the excess of water by pressing the raw peat has so far not proved successful.

*Drying by heat.*—This method has been tried at Mittenwalde, near Berlin, Germany. The apparatus used was constructed by Mr. Stauber.

The raw peat dug out of the bog by cutting machines, was loaded on cars, and brought to the works, where the peat was dumped in large heaps and left until all excess of water had run away. The content of water was thereby decreased to some 80%. From here the peat was dumped into the shoe of an elevator, and conveyed to an apparatus where it was pressed between two wide rubber belts, which further decreased the content of moisture to some 78%. The peat was then brought to a disintegrator and from there to a large rotating cylinder of sheet iron 49.5 feet long, and 7.2 feet in diameter, lined with fireproof material. Two step grate fire-boxes were placed in front of the end, where the peat was brought in, and all the combustion gases were by means of a strong fan, drawn through the cylinder. The evaporation of moisture by this method was exceedingly strong, and when leaving the cylinder, the peat held about 60% moisture. The partially dried peat was then conveyed to another disintegrator, sieved, conveyed to a steam plate drier and treated as previously described in the German briquetting plants.

The plants where this method was introduced are, however, closed down several years ago and probably the economical results were less satisfactory.

*Kerrinne's method of drying peat by means of electric energy.\**—A plant where this method was employed was erected by Ostpreussische Pentan-Werke at Schwenzelmoor near Tilsit.

\* Report by A. Larson. Teknisk Tidsskrift No. 42, year 1903.

The bog, which is a low one, cannot be drained, has an area of 3,700 acres and an average depth of 11.5 feet. The surface layer consists of sphagnum moss with a depth of 1.5-3 feet; the deeper layers are comparatively free from roots and tree stumps. The surface of the bog, which in most cases is water-soaked, cannot be used as drying field and the surrounding country is swampy and less suitable for air drying peat. On this account, the following method, by which the air drying of the peat could at least be partly done away with, was introduced.

The surface layer of sphagnum moss was first dug out in the ordinary way, and brought to the plant, where it was used as fuel under the boilers. An excavator, \*fitted with a "grab scoop," was used for digging the peat. This excavator was placed on a barge floating in the trench worked out, and the peat was loaded into other barges, which, when filled, were brought to the plant and unloaded. During 24 hours about 1,300 cubic yards of raw peat containing 90-92% water were excavated. A steam engine of 6 h.p. furnished the required power, and each shift consisted of two men. Sufficient fuel for the engine was obtained from the roots contained in the peat. The barges used for the transport of the peat were provided with perforated iron bottoms, and during the transport to the plant, part of the water contained in the peat ran off, so that the peat, when unloaded, contained about 89% water. The peat was then conveyed to a disintegrator where it was torn to pieces and mixed into a homogeneous pulp. From the disintegrator the mass was conveyed to a large tank, from which it was tapped into the so-called "osmos" moulds, by means of hoppers with valves. The moulds moved on rollers, and could easily be brought under the hoppers. They were made of wood with interior dimensions 37.2 x 30 x 2 inches, and provided with bottoms of fine brass wires, on which the peat mass rested. During one minute 15 of these moulds were filled. The moulds were loaded on cars and transported to sheds, where they were placed in rows on racks and an electric current of 30 amperes and 220 volts per row (150 moulds) was passed through. The brass net in the bottom of the moulds acts as cathode, and a 0.3 inches thick iron plate of the same dimensions as the interior dimensions of the moulds as anode. The iron plates are hung up by chains and can be raised or lowered by means of a lever for each section. When one section is filled with moulds, the plates are lowered on top of the peat mass, and at the rate the latter sinks, the former follows.

Per mould of 76 sq. feet area and 2 inches depth, a current of 3 volts is required during the summer, and 4.5 volts during the winter. Each row of moulds requires 10 h.p. and as 13 rows are always under drying, one row being unloaded and one filled, the total power required would be 130 h.p. The water starts to run off as soon as the current is put on, and after 4 hours when the current is switched off, the content of water in the peat is brought down to 80%, instead of about 90% when the process started. The moulds which

---

\* Manufactured by Menk & Hambrock in Altona-Hamburg.

then are ready are loaded on cars, and transported to an elevator where the peat is dumped, conveyed to a briquetting press, and pressed into briquettes.

The briquettes are conveyed to a Möller & Pfeiffer's drying oven (similar to the drying oven used for common bricks). The oven is heated with the waste steam from the engines, and is said to evaporate 0.8 lbs. water in the briquettes per 1 lb. steam; the briquettes were left during 24–30 hours, and when taken out, held about 70% of water. The object with the drying was to make the briquettes of such a strength that they could stand handling transportation.

The briquettes were then dumped into buckets and transported by means of an aerial tramway to air drying sheds, where the final drying was done by air drying.

The method was later improved, so that the peat after being treated with the electric current, was said to contain only 50% moisture. In this case pressure was used and the moulds divided into rectangular spaces of the size of the briquettes. These briquettes were then dumped directly into the buckets and transported to the air drying sheds. In this case the drying oven and briquetting press could be omitted.

This process was demonstrated on a small scale. A mould containing peat 4 inches in thickness was subjected to pressure, and at the same time an electric current of 70 volts was passed through during 2 hours. The resulting peat cake was 0.92 inches thick, and contained about 50% moisture. During the test, the temperature of the peat was raised by the current to 60° centigrade, which, when 1 h.p. second is equivalent to  $\frac{1}{8}$  of a calorimeter, is an exceedingly expensive heating process.

Very little is known of the success of this undertaking, but the briquettes made are in no way superior to common air-dried peat bricks, and the cost of manufacture is naturally considerably higher.

*Electro peat coal.*—The above name\* is given to a peat product produced by a method invented by J. B. Bessey. In this process†, the peat is dug from the bog by means of an excavator, fitted with a "grab scoop" which delivers it into small tip wagons, running over a light railway, by means of a wire-rope haulage between the bog and the factory. The wagons, when they arrive at the factory, are emptied into a large hopper, and the peat is by means of a belt conveyor brought into the feed hopper, of a rotary so-called hydro-eliminator, in which it is subjected to a gradually increasing pressure. The eliminator is continuous in its action, the wet peat passing in at the top, and the partly dried peat leaving at the bottom. From here the peat is conveyed to an electrifying machine. The peat falls through a hopper into the trough of the machine, and is pushed forward a short distance by means of a reciprocating plunger, each stroke carrying forward a small charge, the result being a practically constant stream from the outlet. While this is going on, an alternating electric current is passed through the peat. The effect of this cur-

\* The name is entirely misleading, as no coking is done by this process.

† Peat, its use and manufacture, by Björling & Gissing.

rent is to liberate the "latent" water contained in the cells of the peat fibres and bring the peat into such condition that the released water is easily extracted.

For the latter purpose the peat is passed through a second hydro-eliminator placed below the electrifying machine. When partly dried, the peat is discharged from the second hydro-eliminator and lifted by a bucket elevator into the hopper of a crushing and kneading machine, in which the fibrous material is torn and worked into a plastic mass.

The kneading machine consists of a large pan, similar to that of an ordinary mortar mill or edge runner, over the surface of which revolves 4 heavy runners. The peat is fed into the centre of the pan, and is gradually worked over to the outer edge by means of adjustable scrapers, and is eventually discharged from the side of the pan into a screw conveyor, which delivers the macerated peat into a moulding machine.

The moulding machine is of the open mould type, having six dies arranged in such a manner that six blocks are turned out at each revolution. The peat is passed forward into a long die, whence it emerges in the form of briquettes, several charges being in the die simultaneously, so that it is kept sometime under pressure. The briquettes are delivered from the mould of the dies to a revolving table from which they are deflected by means of a scraper on to a belt conveyor, which carries them into the stores. A plant of this description was in operation at Kilberry near Athy, Co. Kildare, Ireland.

This process in its main features is very similar to the method invented by Kerinnes, and can hardly be considered an improvement. As to the cost of manufacture and other details very little is known at present; the name given to the product produced is entirely misleading, no coking is done, and the product is not likely to be in any way superior to the common air-dried peat bricks manufactured by the usual methods. It is also questionable if the cost of the electric energy used will be paid back by the small amount of moisture evaporated, and that the change in the structure of the peat, effected by the passage of the electric current, is as great as claimed.

*The Ekenberg wet carbonizing process.*—This process was invented by Dr. M. Ekenberg, of London, England, and as far as can be judged at present, is the most promising process for the conversion of peat on a large scale into fuel. By this process the raw peat is more or less thoroughly carbonized (depending on the temperature used), which results in a fuel of higher calorific value than the usual peat briquettes. The drying is done entirely by artificial means, whereby the working season is considerably increased, and in some cases can be extended over the greater part of the year. Extensive experiments with this process have been carried out during 1904–1907, and the different apparatus used and machinery required are now claimed to be fully worked out. The process is covered by patents in all civilized countries (in Canada No. 84325 year 1903, and No. 88873 year 1904), and is at present owned by the International Carbonizing Company, Ltd., 81 Cannon street, London, E.C., England.

In order to carry out the experiments on a sufficient scale a plant was erected during 1904–1905 at Stafsjö, Sweden, for which purpose the Swedish Government assisted with 20,000 kronor.

The results obtained at this plant during the later part of 1905 were supervised by Mr. A. Larson and reported on by him to the Swedish Department of Agriculture. From this report most of the following information is obtained.

The laboratory experiments previously done had demonstrated that wet peat as it comes from the bog through heating under pressure at a temperature of 150° centigrade or more, undergoes a twofold change.

1. The peat loses its gelatinous property and becomes amorphous, so that the same physical difference occurs with the peat before and after the heating under pressure, as between gelatinous and amorphous silica. The larger part of the water in the peat can after this treatment easily be removed by pressure, which is impossible with peat in its natural state.

2. A coking takes place during this process, the completeness of which is dependent on the temperature used, and the content of carbon in the remaining mass is increased.

3. During this process no gases are developed, contrary to the dry distillation, when large amounts of gases (containing carbon in some form) are developed, and the percentage of coke obtained thereby considerably decreased.

4. The product obtained can be easily briquetted into solid briquettes after the moisture has been partly pressed out, and the resulting mass is artificially dried. These briquettes do not absorb moisture and are in appearance and weight very similar to coal, provided that the coking and briquetting are done at a sufficiently high temperature.

In coking air-dried peat, retorts hitherto used have been heated from the outside without fluid water being present. As gases are bad conductors of heat, this coking is a time-consuming operation, and it is generally difficult to get the peat in the middle of the retort coked without over-charring the peat near the walls. In the wet carbonizing process the large bulk of water serves as a heat conducting medium, allowing a short and sharply-defined charring with a uniform effect, which corresponds exactly to the temperature used. The charring is thorough, and every particle of peat is exposed to the heat. The process is called "Wet Carbonizing" because the charring medium is fluid hot water.

The effect of the heating at the temperature of 170° centigrade, corresponding to a pressure of 8 atmospheres, is shown in the following table:

Composition of peat.	Raw peat	Wet carbonized peat.	Raw peat	Wet carbonized peat.
	A	A	B	B
Carbon.....	56.00	60.20	55.50	58.50
Hydrogen.....	5.90	6.00	5.70	5.90
Nitrogen.....	1.33	1.38	1.19	1.20
Sulphur.....	0.59	0.40	0.31	0.43
Oxygen.....	32.68	28.32	34.10	30.27
Ash.....	3.50	3.70	3.20	3.70
Calorific value of dried sample, Calories per kg	5640	6240	5610	5990

The analyses show that a coking has taken place, and to a higher degree for peat A, which was better humified than peat B.

Peat	Pressure in atmospheres.	Temperature degrees centigrade.	Ash after wet carbonizing %	Calories per kg. after wet carbonizing	Product obtained %
Well humified peat from Stafsjö. . . .	8	170	3.10	5880	82
do. . . . .	25	225	4.41	6480	70.5
do. . . . .	50	320	4.72	6800	68.3
do. . . . .	75	375	6.03	6870	54.9
Peat from Majenjanka . . . . .	8	170	3.92	6230	76.5
Sphagnum moss . . . . .	8	170	4.30	4710	68.5

This table shows that at higher temperature (with corresponding pressure) more water is removed and the fuel value increased. Even at 375° temperature (75 atm.) very little gas is developed.

The following experiments were made with peat from Stafsjö. The calorific values were determined in air-dried samples.

No.	Temperature degrees centigrade	Product obtained %	Ash %	Calories per kg.
Raw peat C.		....	1.84	5571
1. . . . .	150	88	1.92	5698
2. . . . .	150	87	2.25	5599
3. . . . .	180	78.1	1.91	5856
4. . . . .	180	79.4	2.11	5907
5. . . . .	180	80.7	2.22	5909
6. . . . .	200	79.3	2.20	6123
7. . . . .	200	79.4	2.15	6149
8. . . . .	200	78.2	1.76	6281
9. . . . .	220	74.8	2.43	6128
10. . . . .	220	80.0	2.35	5980
Raw peat D.		....	2.97	5452
11. . . . .	150	86	2.93	5553
12. . . . .	150	90	2.92	5510
13. . . . .	180	80.1	2.97	5759
14. . . . .	180	79.5	3.05	5801
15. . . . .	180	80.5	2.72	5783
16. . . . .	200	71.3	2.78	5963
17. . . . .	200	70.1	2.89	5783
18. . . . .	220	72.0	2.84	5616
19. . . . .	220	73.6	2.35	5995
20. . . . .	220	76.5	2.47	6075

In a laboratory screw press well humified wet carbonized (at 180°) peat has been pressed so that the pressed cake held only 30% moisture.



The following experiments were made at the laboratory in order to demonstrate the relation of the pressure used to the contents of moisture in the pressed carbonized peat.

Pressure used atmospheres.	% Moisture left in the peat coke.	
1.1	80.8	Raw peat A. Pressing test I. Wet carbonized at 180° Centigrade. 12% dry substance in the carbonized mass. Calorific value of the raw peat 5571 calories per kg. Calorific value of the carbonized peat 5881 calories per kg. Product obtained 78.8% of the raw peat.
1.5	73.2	
3.0	70.0	
6.0	68.4	
14.7	67.3	
33.3	63.3	
60.3	58.8	
90.0	54.4	
143.7	48.7	
220.0	44.7	
287.0	39.3	
10.7	72.0	Raw Peat A. Pressing test II. Wet carbonized at 210° Centigrade. 10.9% dry substance in the carbonized mass. Calorific value of the raw peat 5571 calories per kg. Calorific value of the carbonized peat 6215 calories per kg. Product obtained 78.8% of the raw peat.
16.0	68.1	
34.3	64.8	
65.0	57.4	
97.0	52.8	
156.0	50.0	
232.0	46.8	
310.0	43.0	
1.5	81.0	Raw peat B. Wet carbonized at 180° Centigrade. 11.2% dry substance in the carbonized mass. Calorific value of the raw peat 5452 calories per kg. Calorific value of the carbonized peat 5780 calories per kg. Product obtained 79.8% of the raw peat.
3.3	77.1	
4.4	74.8	
6.5	73.1	
10.1	70.4	
38.3	66.1	
75.3	59.6	
112.5	54.6	
178.0	51.1	
263.0	48.0	
350.0	45.0	

The experiments show that with the peat tried a pressure higher than 150 atmospheres is not practical. The content of moisture with higher pressure does not decrease in the same ratio as the difficulties of obtaining higher pressure increases.

The dried peat obtained contains about 3% (depending on the peat used) of a paraffin substance, which, melting at about 90° centigrade, acts as binding material in the briquettes made. Briquettes containing no moisture can therefore be produced from wet carbonized peat if the temperature is kept at 100° centigrade or more during the briquetting process. Such briquettes have a calorific value of 6,000 calories per kg. or more, weigh about 50 lbs. per cubic foot, or more, and contain therefore, per cubic, unit about the same fuel value as ordinary coal.

The process at the Stafsjö plant is carried out in the following manner: In order to obtain a thoroughly pulped and homogeneous peat mass a

special pulping machine was constructed. This machine is an Anrep machine, where the mouthpiece is removed and a steel plate inserted in its place. The steel plate is provided with a number of holes, the total area of which is equal to the free area of any section of the machine. In front of the steel plate is placed a rotating knife, which keeps the holes clean and cuts any fibrous material not previously pulped. This machine proved quite satisfactory and delivered easily, with about 50 h.p., 350 cubic meters\* peat mass per 8 hours. The power required is furnished by an electric motor.

The pulped peat mass is transported to the plant in dumping cars, and delivered to an elevator which conveys it to a large tank, holding enough material to keep the plant running for six days, in order to be independent of any repairs needed or stoppages on the bog.

The next stage of the process is to bring the peat mass continuously in and out of the apparatus where it is heated under pressure to a temperature of more than 150° centigrade. For this purpose different pumps were investigated, and a small so-called "Brei pump," manufactured by H. Eberhardt in Wolfenbüttel, Germany, was first tried. This pump proved very satisfactory, even at 30 atmospheres pressure, and a larger pump of the same construction with a capacity of 350 cubic meters\* per 24 hours was therefore set up at Stafsjö. After a few minor alterations had been made, this pump worked to satisfaction even with a peat mass containing 15% dry peat substance, and it was found that the valves worked better and more quietly with a thick peat mass than with a thin one.

The peat mass is brought to the pump from the tank by means of a specially constructed elevator.

The principle of the apparatus used for heating the peat mass is shown in Fig. 171. It consists of a system of double pipes, one outer and one inner, the latter provided with a screw thread, and appliances for revolving it.

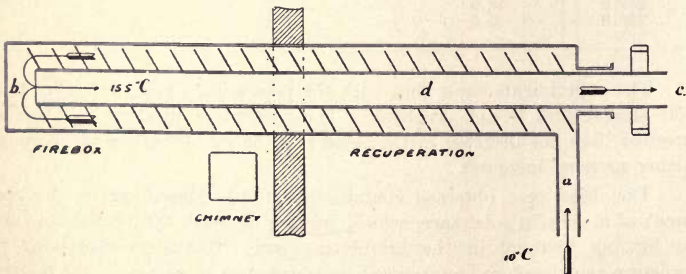


FIG. 171—Theoretical working of a Wet Carbonizing Oven.

One oven consists of 52 such double pipes, with a joint inlet to all the outer pipes, and a joint outlet for all the inner pipes. The pump forces the peat mass into the spaces between the pipes, and by the rotating inner pipe with its screw threads the peat mass is moved forward in the direction of the pressure.

\* 1 Cub. meter=35.3 cub. feet.

The pipes used at Stafsjö are 11 meters\* long. Only considering one of the pipes in the system, the process is as follows:

The peat mass is forced in at (a) and by the screw on pipe (d) and the pressure moved forward towards (b) where it turns and moves through the inner pipe (d) towards the outlet (c) which is combined with a regulator, so that an even pressure is always maintained. One half of the pipe is heated to the required temperature from a fire-box (at Stafsjö the temperature has been kept at 150°–155° Centigrade). The peat mass forced in is consequently heated during its passage from (a) to (b) first by the heat from the outgoing mass, a great part of which is transmitted to the incoming mass, and later from the fire in the fire-box, where it is hottest. The peat has there a temperature of say 155° centigrade. The velocity of the peat mass is such that it passes through the oven in about 15 minutes, during which time the carbonizing process takes place. A temperature of 155° centigrade corresponds to a pressure of 5.5 atmospheres, but in order to be sure that no steam may be formed, a pressure of 10 atmospheres is kept by the pump. When no steam is formed (with the required latent heat) the mass forced in has the same heat capacity as the mass pressed out, and theoretically should be able to absorb all the heat contained in the outgoing mass, in which case the in and outgoing masses should have the same temperature if the pipes could practically be made long enough. With the oven used at Stafsjö, with pipes 11 meters long and a maximum temperature of 155° centigrade, the outgoing peat mass has a temperature of about 80° centigrade, when the temperature of the ingoing mass is about 10° cent., *i.e.*, per kg., peat mass 70 calories are lost in the outgoing mass. The experiments at Stafsjö on a large scale have further shown that per meter pipe in the recuperative part of the oven, the temperature decreases towards the outlet with 12°–13° centigrade.

The heat economy in the wet carbonizing oven at Stafsjö was as follows:

In the oven is utilized of the calorific value of the fuel . . . . .	.70%
Through radiation, etc., is lost . . . . .	7%
The waste gases contain . . . . .	23%

The carbonized peat is conveyed to a filter press,† which at present is being improved, so that the peat, when leaving the press, has about 55% moisture content. The later drying and briquetting are done as previously described in the German peat and lignite briquetting plants.

From the results obtained at Stafsjö, and his previous experience in peat and briquette manufacture, Mr. A. Larson gives the following estimate as to the cost of production and the possibilities of the process.

The production is assumed to be 30,000 tons‡ per year of 200 working days, which is the time the bog at Stafsjö can be worked. 150 tons of briquettes shall then be produced in 24 hours, for which production 3 briquetting presses are required.

\* 1 Meter=3.3 feet.

† The construction and results obtained with this press are not yet available, but according to Dr. M. Ekenberg, this part of the process is also satisfactorily worked out.

‡ In this estimate, metric tons and measures are used. 1 metric ton=1,000 kg.=2,200 lbs.

## Power Required.

6 Pulping machines, each with a capacity of at least 350 tons pulped peat per 8 hours, or a total of 2,100 tons per day, each of 60 h.p. . . . .	eff. H.P.	360
Transportation arrangements on the bog and at the plant. . . . .	"	60
6 "Brie pumps" with elevators, each of 25 h.p. during 24 hours. . . . .	"	150
Wet carbonizing ovens: 5 units of 10 pipes each require at the most 25 h.p. for each unit, and deliver at least 250 tons carbonized peat mass per 24 hours. At the most, 9 ovens are required, or per 24 hours. . . . .	"	225
Lighting plant, etc., 25 h.p. during 10 hours . . .	"	25
About 10% loss on transmission (electric current) of 820 h.p. . . . .	"	80
3 Briquetting presses of 100 indicated H.P. ind.	H.P.	300

The consumption of high pressure superheated steam is, at the highest, 10 kg. per eff. H.P. hour, with the exception of the briquetting presses, where the consumption is 12 kg. per indicated H.P. hour.

The steam required is then:

360 eff. H.P. during 8 hours . . . . .	28,800 kg.
60 " " 8 " . . . . .	4,800 "
150 " " 24 " . . . . .	36,000 "
225 " " 24 " . . . . .	54,000 "
25 " " 10 " . . . . .	2,500 "
80 " " 24 " . . . . .	19,200 "
300 ind. H. P. " 24 " 300 x 12 x 24. . . . .	86,400 "

Total kg. steam per 24 hours . . . . . 231,700 "

The steam is superheated to 385° Cent. and has 11 atmospheres pressure corresponding to 185° Cent., and is consequently superheated 200° Cent.

1 Kg. steam of 185° Cent. contains. . . . .	663 calories
200° superheating corresponds to 0.48 x 200 . . .	96 "

Total . . . . . 759

Assuming that the feed water (condensed steam) has a temperature of 90° Cent., should be deducted . . . . .	90 "
---	------

The required heat per kg. water is then. . . . . 669 "

With 60% efficiency of the fuel, the heat required per kg. steam is  $\frac{669}{0.6} = 1,115$  calories. The fuel contains 5,600 calories per kg. One kg. fuel, therefore, produces  $\frac{5,600}{1,115} = 5$  kg. steam. In order to produce the 231,700 kg. steam required per 24 hours,  $\frac{231,700}{5} = 46,340$  kg. wet carbonized dry substance, or, in round numbers, 46,500 kg. are required.

The plant shall produce 150,000 kg. briquettes per 24 hours, corresponding to 196,500 kg. wet carbonized dry substance, including the fuel for the boilers, but not including the fuel for the carbonizing ovens.

Experience has shown that 70 calories per kg. are lost per kg. peat during the carbonizing process. The raw peat contains on an average 12.5% dry peat substance in drained bogs of average quality (in Sweden).

With a temperature of 150° Cent. in the carbonizing oven, 86–90% wet carbonized dry substance is obtained per 100% dry substance in the raw peat. This carbonized dry substance has a calorific value of at least 5,600 calories per kg.

Assuming that 85% of the dry peat substance in the raw peat is obtained as dry carbonized substance, then 1,000 kg. raw peat containing 125 kg. dry peat substance produce  $0.85 \times 125 = 106$  kg. carbonized dry substance.

Experience has further shown that the heat efficiency of the fuel in the oven is 70–80%, or say 70%. Through radiation, etc., is lost 7%, and in the waste gases 23%, or, assuming these losses to be 10% and 20% respectively, there will be required per 1,000 kg. raw peat,  $\frac{70 \times 1,000}{0.7 \times 5,600} = 18$  kg. dry carbonized peat with a calorific value of 5,600 calories per kg.

The carbonized dry substance which is obtained from 1,000 kg. raw peat is, then,  $106 - 18 = 88$  kg., *i.e.*, for 1,000 kg. carbonized dry substance are required  $\frac{18 \times 1,000}{88} = 205$  kg. fuel of the same quality.

The heat carried away by the waste gases from the carbonizing oven is  $0.2 \times 205 \times 5,600 = 229,600$  calories per 1,000 kg. briquettes.

In order to produce 196,500 kg. briquettes there will be required  $196,500 + 196.5 \times 205 = 236,782$  kg. carbonized dry substance, which corresponds to  $\frac{236,782}{0.85 \times 0.125} = 2,230,000$  kg. raw peat per day.

The waste heat available for the drying of the pressed carbonized peat is as follows:—

The waste gases from the fuel used for heating the boilers contain, in accordance with the assumption made, 30% of the heat value of the fuel, or	
46,500 x 5,600 x 0.3 .....	78,120,000 calories
The waste gases from the carbonizing ovens contain	
196.5 x 205 x 5,600 x 0.2 .....	45,116,400 "
	<hr/>
Total.....	123,236,400 "

According to Hausbrand ("Das Trocknen mit Luft und Dampf," page 34), if the temperature of the outer air  $\frac{3}{4}$  saturated with moisture is 10° cent., and the temperature of the air used for drying also  $\frac{3}{4}$  saturated with steam, is at the beginning 100° cent., then 82,265 calories are required for the evaporation of 100 kg. water. Consequently the above 123,236,400 calories are capable of evaporating  $\frac{123,236,400 \times 100}{82,265} = 149,800$  kg. water.

The 231,700 kg. exhaust steam contain 500 x 231,700 = 115,850,000 calories latent heat, of which at least 70% can be used for evaporation of moisture, *i.e.*, for drying. By this heat  $\frac{0.7 \times 115,850,000}{640} = 126,700$  kg. water can be evaporated.

With the total waste heat 276,500 kg. water can therefore be evaporated.

The total carbonized dry substance per 24 hours was 236,782 kg., and the briquettes produced 150,000 kg., consequently the fuel consumption is 86,782 kg., or 37%.

In order that the available waste heat may be sufficient to dry the whole mass of carbonized and pressed peat, this mass can contain 276,500 kg. water, or  $\frac{276,500 \times 100}{236,782 + 276,500} = 54\%$  of moisture, in round figures. The content of moisture in the carbonized peat must be mechanically pressed down to this percentage in order that the fuel consumption given above may be correct.

The consumption of raw peat was per day 2,230,000 kg., or per 200 days 446,000,000, kg. corresponding to 446,000 cubic meters per year.

In a drained bog with an average depth of 2.5 meters (8.25 feet), this production corresponds to an area of about 18 hectare (44.5 acres). Assuming the price of the bog to be 500 kronor per hectare, the yearly cost is 9,000 kronor, or 0.30 kronor per ton briquettes.

Cost of digging the peat, with Ekholm's elevator:

Elevator with motor, etc., costs about 3,000 kronor.	
10% amortization per year of 200 days.....	kronor 300
5% for repairs .....	" 150
5% interest .....	" 150
	<hr/>
Total.....	" 600

or per day kronor 3.00.

With Ekholm's elevator 50 cubic meters of raw peat can be dug out from the bog per man and day. Each peat pulping machine of 350 cubic meters capacity requires, therefore, per day of 10 hours, 7 diggers, or 9 diggers during 8 hours,

at 3.50 kronor per 8-hour day . . . . .	kronor	31.50
Amortization, interest and repairs, per day . . . . .	"	3.00
Oil, etc. (the cost of power is already included in the cost of fuel for the plant)	"	0.50
Total . . . . .	"	35.00

or per cubic meter, 0.10 kronor.

The cost of transporting the peat to the elevator at the coking plant is equal to the wages of three men plus the amortization, etc., of the appliances used, which would in this case be Anrep's cable transport with endless cable and dumping cars. One man couples the cars to the cable, the second uncouples them, and the third dumps their content into the elevator shoe. This work is light, and these men could be had for 3.00 kronor per day.

The cost per 350 cub. meters would then amount to 10.50 kronor, or, per cub. meter, 0.03 kronor. The total cost for digging and transport is therefore 0.13 kronor per cub. meter, or, per year,  $446,000 \times 0.13 = 57,980$  kronor, and per ton briquettes 1.93 kronor.

Cost in the plant.—According to the experience obtained in the large number of lignite briquetting plants in Germany, the total labour cost at a plant with three presses is 1.44 kronor per 1,000 kg. briquettes; in this case the cost of the labour required for the wet carbonizing ovens and the filter presses must be added, making a total of about 2.00 kronor per 1,000 kg. briquettes.

Amortization of the plant, etc.—The cost of a plant with a yearly capacity of 30,000 tons briquettes would probably be about 600,000 kronor (the cost of the bog is previously taken into account). With 5% interest, 5% amortization, 5% for maintenance, and 5% further amortization on certain machines, which constitute about one-fifth of the total cost, or 1% of the whole cost, a total of 16%, equal to 96,000 kronor per year, is reached, or 3.20 kronor per ton briquettes. Administration, etc., and unforeseen expenditure can be estimated at 30,000 kronor per year, or 1 kronor per ton briquettes.

The cost per ton briquettes is, then:\*

	Metric ton kronor	Ton of 2,000 lbs. dollars
Bog . . . . .	0.30	0.07
Digging and transport of raw peat . . . . .	1.93	0.48
Labour cost at plant . . . . .	2.00	0.50
Amortization, interest, etc. . . . .	3.20	0.80
Administration, etc. . . . .	1.00	0.25
Extra . . . . .	0.57	0.15
Total . . . . .	9.00	2.25

\*Under the assumption that the water content of the carbonized peat can be mechanically and economically pressed down to about 55% moisture. The power required for these presses is not given in this estimate by Mr. A. Larson.

In bogs where the digging of the peat can be done with mechanical excavators, the cost of this item is considerably decreased.

According to Dr. Ekenberg, the cost per ton briquettes in a factory producing 20,000 to 30,000 tons per year is as follows:—

	s.*	d.
The raw peat in the bog (including fuel used in the factory) . . .	0	8
Wages for excavation and transport of the raw peat to the factory . . . . .	2	0
Wages in the factory . . . . .	2	3
Depreciation and maintenance of plant . . . . .	2	6
Administration and sundry expenses . . . . .	1	4
Total cost of briquettes per ton . . . . .	8	9

---

\* 1 shilling=24 cents.



## CHAPTER V.

## PEAT POWDER.

A method for the manufacture of peat powder, which experts\* consider to be very promising, has lately been invented by Mr. H. Ekelund, Jönköping, Sweden. The details of this process are for the present kept secret, on account of the patents not yet being fully established.

The raw material for the process is cut peat which is partially air dried, and afterwards artificially dried and pulverised. The raw peat is left in the open during the winter to freeze, which in this case, instead of being injurious to the peat, makes it easier to pulverize, and furthermore allows the bog to be worked during a much longer period than is the case in the manufacture of common air-dried peat fuel.

The peat powder manufactured by this process does not absorb moisture, and has about the same specific weight as coal. The cost of manufacture, including all expenditure, will not exceed \$2.35 per ton, and the cost of a plant with a yearly capacity of 12,000 tons, is, according to the inventor, about \$10,000, (not including bog and arrangements on same.)

The firing with powdered fuels gives a higher fuel efficiency on account of the intimate mixture with the air used for the combustion, and the possibility of regulating this supply of air to an amount as near as possible to that which is theoretically required for the combustion. The firing with powdered fuel is furthermore smokeless, and requires less attention and skill than the firing in the old way.

Coal powder has been used for a long time, especially in cement manufacturing plants, but in order to give satisfactory combustion, it must be exceedingly fine, which increases the cost considerably. Peat powder, on the other hand, is more porous, and ignites at a lower temperature, whereby a complete combustion can be obtained without crushing the peat so thoroughly. A further advantage with the powder is that the temperature can be easily regulated as required, and if desired, a very high temperature can be obtained.

During the year 1907, experiments with peat powder were carried out under the supervision of Professor Odelstjerna, of Stockholm, Sweden, in a furnace used for melting crucible steel. In regard to the results obtained, Prof. Odelstjerna says:

1. The fuel is very easily ignited in the fire-box, but no danger of self ignition; which is often the case with other powdered and somewhat moist fuels, need be feared.

\*Professor E. G:son Odelstjerna, Stockholm, Sweden, and Captain E. Wallgren, Chief Engineer to the Swedish Department of Agriculture.

2. The combustion of the fuel can be easily regulated so that the ash is always free from any unburnt particles of carbon, and so that the carbon and hydrocarbons in the fuel will be at once completely burnt to carbon dioxide and water, thus giving the highest temperature with either a weak or a strong oxidizing flame, (the former with just enough air for the combustion, and the latter with excess of air). The combustion can also be so regulated that a producer gas with only a small percentage of carbon dioxide and of comparatively high temperature (light red heat) is formed. This hot gas is then carried to the furnace room proper, where it is burnt to carbon dioxide and water, there giving the highest temperature. This producer gas can be used for reduction or in reheating furnaces where the heated material must be kept from oxidization and then afterwards burnt in other furnaces.

3. The change from oxidizing to reducing flame, or vice versa can be very easily and quickly done.

4. The quantity of the fuel and the required amount of air can at any time, and in either of the above cases, be exactly regulated as required; and in case no change is required, no attendance is necessary after the valves\* are once regulated.

5. The powder gives the highest temperature which can be employed in furnaces with a considerably less consumption than can be obtained with any of the other solid fuels, and it can be used for the melting of glass, cast iron, steel, soft iron and other metals. The right temperature is more quickly obtained through the combustion of the powder than by the older methods.

6. Furnaces for using this fuel are considerably cheaper to erect than those designed for the use of other fuels.

---

\*In the apparatus also invented by H. Ekelund.

## CHAPTER VI.

## PEAT COKE

The oldest method of coking peat, which is still used to some extent, is coking in heaps in the same manner as that used for the manufacture of charcoal. Later, ovens of different construction, but discontinuous in their operation were employed, but at present time coking in retorts, which operate continuously, and which are combined with apparatus for the saving of the by-products on a commercial scale, are mostly used.

The raw material used for peat coking is air-dried machine peat, and the better pulped, humified and ash free the raw peat is, the better is the quality of the coke produced.

## COKING IN HEAPS.

This method is still used at Triangel, Germany. The air-dried machine peat is cut in lengths, of about 2 feet, which are raised on end in the coking heaps. The heaps are 20 feet in diameter, about 11 feet in height, and from each heap about 11 tons peat coke are obtained. When the heap is piled up, the peat is first covered by a layer of dry grass and then with a covering of fines, 4 inches thick, obtained from former operations. The coking is done in exactly the same manner as that followed when coking wood in heaps, and requires about two weeks.

The manufacture of peat coke by this method is not likely to be much used on account of the difficulties and uncertainties connected with it. This method is also more expensive and wasteful than coking in retorts.

## COKING IN OVENS.

Discontinuous coking in ovens is not much more advantageous than coking in heaps, but the attendance is easier, the process is independent of weather conditions, and some of the by-products can be easily saved. At the present time very few of these ovens are in operation.

*The Hahnemann oven*\*:—This oven, see Fig. 172, consists of a cylindrical shaft with the bottom raised, as shown in the figure. An opening (c) closed by an iron plate, is left on one side for the removal of the coke, and on the other side is a pipe (r) in communication with the condensing apparatus. The lower part of the shaft is provided with three rows of holes for admittance of the necessary air, and in the center of the shaft is placed an iron pipe (E) provided with holes (a) at its base, through which the gases can escape. When

\*Hausding and Larson & Wallgren's reports.

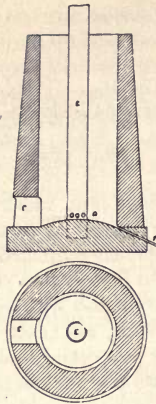
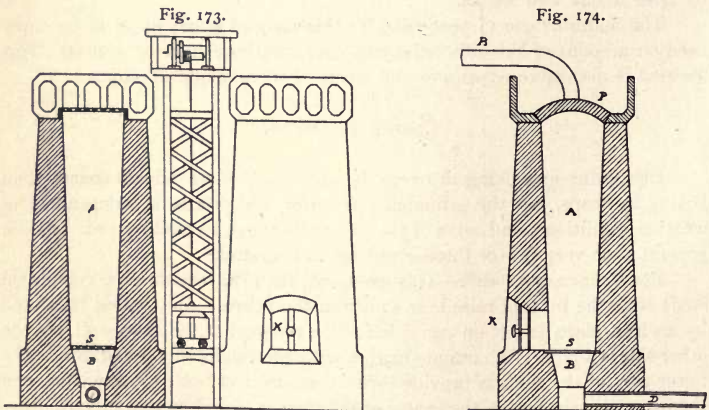


FIG. 172—The Hahnemann Peat Coking Oven.

the shaft is filled with peat, the latter is ignited on top, the shaft opening is then closed by iron plates and the coking process regulated through the different air holes.

*The Wagenmann oven\**:—This oven, see Fig. 173, consists of two cones (A) and (B) separated by a grate (S). The upper cone (A) is 6.6 feet high and the lower one (B) 1.6 feet. On one side of the latter is a pipe (D) serving as outlet for tar and gases. The coke is taken out through the opening (K), which is at the same height as grate (S). The cone (A) is filled from above with



The Wagenmann Peat Coking Oven.

\* Hausding and Larson & Wallgren's reports.

peat, which is ignited on top. When the peat is burning the opening is closed and the coking process regulated by air holes placed in the walls. Fig. 174 shows the same oven, but with the opening on top covered by a cover (P), provided with a pipe (R) serving as outlet for the gases. In this case the pipe (D) is omitted.

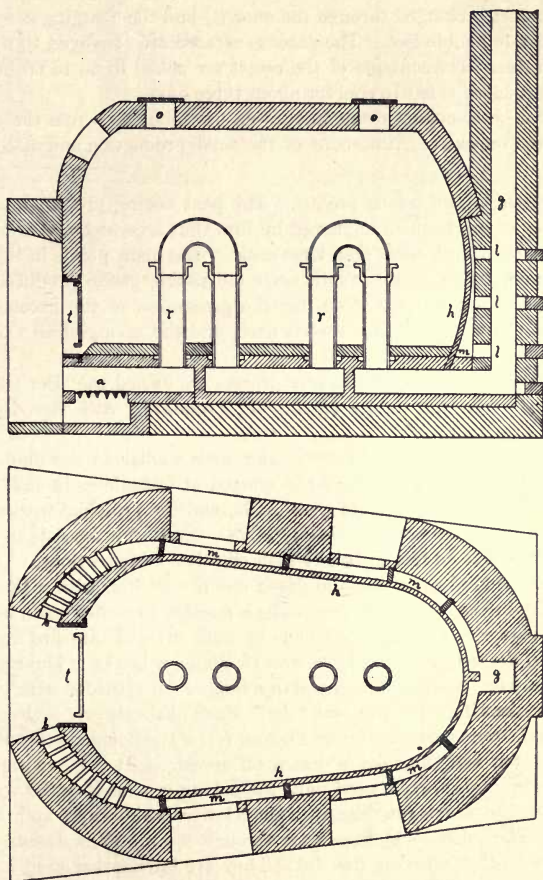


FIG. 175—The Lottmann Peat Coking Oven.

*The Lottmann Oven\*.*—In this oven, see Fig. 175, a special fuel which can be of poorer quality is used for producing the necessary heat. The widest part

\*Hausding.

of the oven or retort is 9.24 and the narrower part 7.6 feet. The retort is heated by the gases from the grate (a) and the grates (b). The gases from the grate (a) are drawn through cast iron pipes (r), whereby the interior of the retort is heated, and the gases from the grates (b) circulate around the thin walls (h) through the canals (m) and through the holes (l) out in the chimney (g).

The retort is charged through the door (t) and the charging holes (o) and holds about 700 cubic feet. The gases generated are conveyed to a condensing apparatus. The contents of the retort are coked in 50 to 60 hours, and the coke produced is left to cool for about three days.

Several other coking ovens have been used, but as a rule the coke produced is too expensive on account of the small production and discontinuous working.

*M. Ziegler's peat coking process.*—The peat coking process invented by Mr. M. Ziegler has been so improved by him that a commercial manufacture of peat coke is now possible on a large scale. The main points in this process are the employment of the waste non-condensable gases, produced by the dry distillation of the peat itself, for the generation of the necessary heat, the continuous working of the retorts used, and the saving of all valuable by products.

The patents covering the Ziegler process are owned by "Der Oberbayerischen Kokswerke und Fabrik chemischer Produkte," Akt. Ges. Beuerberg, Bavaria, Germany.

The first retorts invented by Ziegler were similar to the ones used for coking lignites, and such a plant was erected at Oldenburg in 1894. Later, however, several improvements were made, and the principal features of the retorts now used are shown in Figs. 176–178. Each unit consists of two vertical retorts about 40 feet in height with elliptical cross-sections. The lower half is built of fire-bricks, and the upper one of cast iron with a thin outside lining of fire-bricks. Outside these walls is another fire-brick shell, leaving an air space between, which is by means of walls divided into fire flues. The whole oven is then protected by a wall of common bricks. The retorts rest upon a cast iron foundation, and end in a hopper (a) provided with two openings for the drawing off of the peat coke. Each of the retorts is closed on top by cast iron covers carrying the feed boxes (c). The openings through which the peat is fed and the coke is drawn off are air tight. When the oven is started, extra fuel must be used until the coking process is under way. For this purpose the oven is provided with three lower fire-boxes (d) and two upper ones (e). The combustion gases pass through the fire flues (f) and (g), and from there to the collecting flue (h). They are later either used for drying of the peat in specially constructed drying chambers, or escape through the chimney. Each zone of the oven (each fire flue) is provided with a peep hole on the front and rear side for the purpose of watching and taking the temperature. In the lower fire flues, the temperature reaches some 1,000° Centigrade, and in the upper ones, 600°, 500°, and 400° respectively. The highest tem-

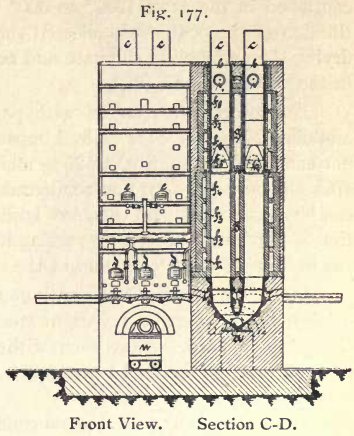
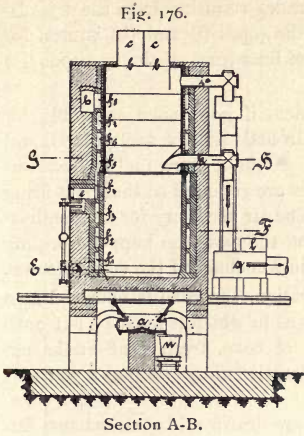
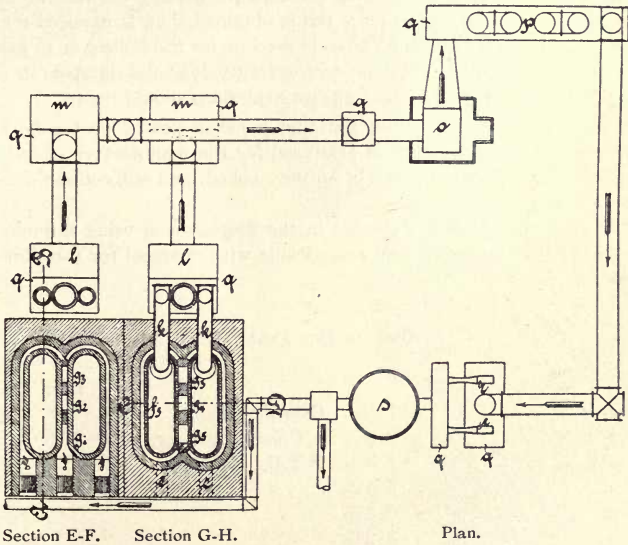


Fig. 178.



M. Ziegler's Peat Coking Retorts.

perature in the retorts themselves reaches some 600° centigrade. The heat contained in the gases (200° to 300° centigrade) resulting from the dry distillation of the peat, and collected through the pipes (i) and (k) is used for drying the ammonium sulphate and acetate of lime (part of the by-products) in the vessels (l) and (m).

The retorts are charged with peat, which, if good coke especially for metallurgical purposes is desired, must contain little ash, be well pulped, and not contain more than 20 to 25% moisture. At first, extra fuel is used, but after 48 hours sufficient non-condensable gases are given off so that peat firing can be discontinued and the gases ignited. The air necessary for the combustion is previously heated by passing it around the cast iron hoppers forming the bottom of the retorts, and at the same time cooling off the coke in same.

When the process is in continuous operation, the coke is hourly drawn off from the hoppers into air-tight steel cars (n) in which it must be left until thoroughly cooled. After each withdrawal of coke, fresh peat bricks are charged through the feed boxes (c). The operation thus becomes a continuous one.

The water vapours and gases generated are drawn off by an exhaust fan (o)\* and driven through an air cooled pipe condenser (p) where the tar and tar water condense. The non-condensable gases are by means of another fan forced back to the oven where they are used for heating the retorts. At a plant with a number of ovens more gas is obtained than is required for this purpose, and in such cases the excess is used under the boilers or in gas engines. The gas circuit is provided with safety valves and dampers in order to save the condensing apparatus in case explosions should occur.

Besides the manufacture of thoroughly coked peat, "peat coke" described above, the Ziegler oven is also used for the manufacture of so-called "peat half coke," which is peat not entirely coked, and still containing some of the heavy hydrocarbons.

The peat coke as manufactured in the Ziegler oven using suitable raw material is hard and strong and comparable with charcoal for metallurgical purposes.

#### Analysis of Dry Peat Coke.

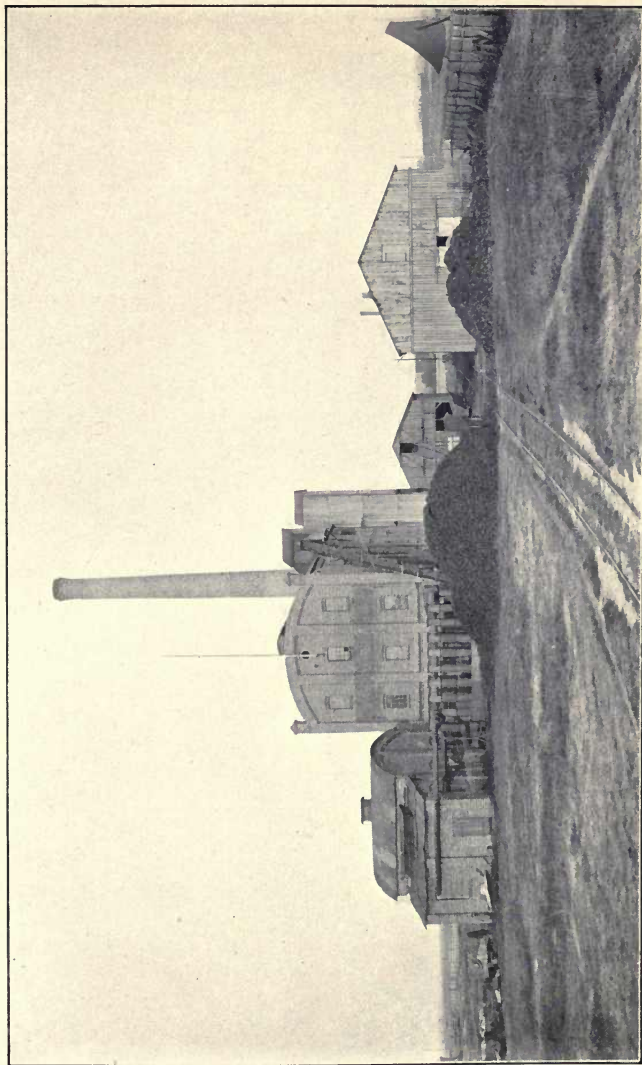
			High	Low
Carbon. ....	87.8%	Calorific value,		
Hydrogen. ....	2.0%	Colories per kg. ....	7,889	7,805
Nitrogen. ....	1.3%	B.T.U. ....	14,200	14,049
Oxygen. ....	5.5%			
Sulphur. ....	0.3%			
Ash. ....	3.2%			

Peat coke is used in blast furnaces, and for other metallurgical purposes.

\*First passing through the vessels (l) and (m) as formerly described.



PLATE 29.



Peat Coking Plant at Oldenburg, Germany.



Powdered peat coal is used for hardening armor plate, and for various other uses.

#### Analysis of Peat Half Coke.

Carbon.....	73.89%	Calorific value,	
Hydrogen.....	3.59%	Calories per kg.....	6,700
Nitrogen.....	1.49%		
Oxygen.....	14.52%	B.T.U.....	12,060
Sulphur.....	0.20%		
Ash.....	2.50%		
Moisture (at 105°C.)....	3.80%		

Peat half coke is used for firing locomotives and boilers and burns with a long flame.

Peat tar is nearly of the same composition as the lignite tar, but has a higher content of creosote; by distilling and refining the tar a number of different substances are obtained, such as:

Light oils, which can be used either for illuminating purposes or for the manufacture of oil gas.

Heavy oils which are used for lubricating purposes.

Paraffin, phenol and asphalt.

Tar Water.—The tar water contains: ammonia, acetic acid and methyl alcohol, which are manufactured into: ammonium sulphate, acetate of lime and methyl alcohol.

Up to the present time three plants equipped with Ziegler's coking ovens are in operation.

*The Oldenburg Plant, Oldenburg, Germany.*—This plant (see Plate 29) has five ovens of the older type and a complete plant for the saving of all the by-products. This plant was investigated in 1901 on behalf of the Prussian Government by a Commission, with Mr. L. C. Wolff as chairman. An abstract\* of the results obtained is given below:

The peat used during the trial contained:

Carbon.....	35.3%	Oxygen.....	28.4%
Hydrogen.....	3.4%	Ash.....	0.9%
Nitrogen.....	0.7%	Moisture.....	31.0%
Sulphur.....	0.1%		

and had a calorific value of 3792—3423 calories per kg. or 7825—6161 B.T.U. per lb.

\*Zeitschrift des Vereines Deutscher Ingenieure No. 24, year 1904.

Of 576 tons=100% peat were obtained.

163.7	tons peat coke	.....	=28.4 %	(as measured)
157.1	“ peat coke	.....	=27.3 %	(when dried)
25.8	“ tar	.....	= 4.5 %	
269.0	“ tar water	.....	=46.6 %	(as measured)
179.4	“ tar water	.....	=31.2 %	(not diluted)
330.0	“ gases	.....	=57.3 %	(as measured)
213.4	“ gases	.....	=37.0 %	(without air)
0.32	“ loss	.....	= 0.05%	

The 25.8 tons tar obtained gave:—

11.6	tons light oils	.....	=2.0%	} 4.5%
3.9	“ heavy oils	.....	=0.7%	
1.8	“ paraffin	.....	=0.3%	
7.6	“ phenol	.....	=1.3%	
0.8	“ asphalt	.....	=0.2%	

The 269.0 tons tar water obtained gave.—

1.8	tons methyl alcohol	.....	=0.34%
0.9	“ ammonia	.....	=0.16%
(1.6	“ sulphate of ammonia	.....	=0.31%)
2.5	“ acetic acid	.....	=0.44%
(2.8	“ acetate of potassium	.....	=0.50%)

Water and loss not ascertained

The non-condensable gas had the following composition:—

	By Weight	By Volume
CO <sub>2</sub> .....	48.8%	27.4%
O.....	2.8%	2.2%
N.....	25.5%	22.5%
CO.....	9.7%	8.6%
CH <sub>4</sub> .....	9.6%	14.8%
C <sub>n</sub> H <sub>m</sub> .....	1.7%	1.0%
H.....	1.9%	23.6%

and had a calorific value (maximum) of 2877 calories per cubic meter, or 322 B.T.U. per cubic foot.

The cost of production per ton peat coke during the summer 1901 when peat with lower contents of moisture was used, was as follows\*:

3 tons peat at 5.09 marks per ton	.....	15.27 marks.
Labour cost per ton coke	.....	4.55 “
Lease of plant and bog	.....	1.52 “
Repairs and maintenance	.....	1.82 “
Miscellaneous	.....	1.82 “

Total ..... 24.98 “

\*According to Larson and Wallgren.

From this should be deducted the value of the by-products\* obtained per ton peat (in this case with 31% moisture), or

	market price per 100 lbs.		
54 lbs. oils . . . . .	16.36	marks =	8.83 marks
6 lbs. paraffin . . . . .	34.09	" =	2.04 "
26 lbs. phenol. . . . .	81.36	" =	21.15 "
4 lbs. asphalt . . . . .	6.82	" =	0.27 "
6.8 lbs. methyl alcohol. . . . .	56.82	" =	3.86 "
6.2 lbs. ammonium sulphate. . . . .	15.45	" =	0.96 "
10 lbs. acetate of lime. . . . .	9.55	" =	0.96 "
			38.07 "
	Total. . . . .		

In this estimate the costs of the raw materials used in the chemical part of the plant are not included, nor the amortization of the peat machines, etc., but the value of the by-products, if the above prices are obtained, should more than cover all expenses and the peat coke itself be obtained free.

In Germany the best peat coke suitable for metallurgical purposes sells for 55 marks per ton, and even at higher prices; fines and poorer grades sell from 27-36 marks per ton.

*The Redkino Plant.*—The Russian Government built in 1901 at Redkino a peat coking plant with 8 ovens, see Fig. 179, according to the Ziegler system. The object of this plant is not so much the manufacture of peat coke as that of half coke for use as fuel in locomotives.

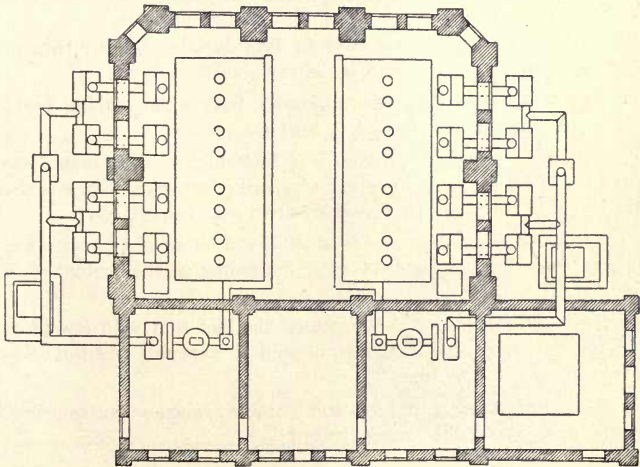


FIG. 179—8-Oven Peat Coking Plant at Redkino, Russia.

\*According to Wolff.

The peat bog belonging to this plant, see Fig. 180, is some 3,200\* acres in extent, and is worked by 20 Anreps peat machines, as shown in the figure. These machines produce a yearly quantity of peat corresponding to 66,000 tons air-dried peat, which in 300 days is coked in the coking plant.

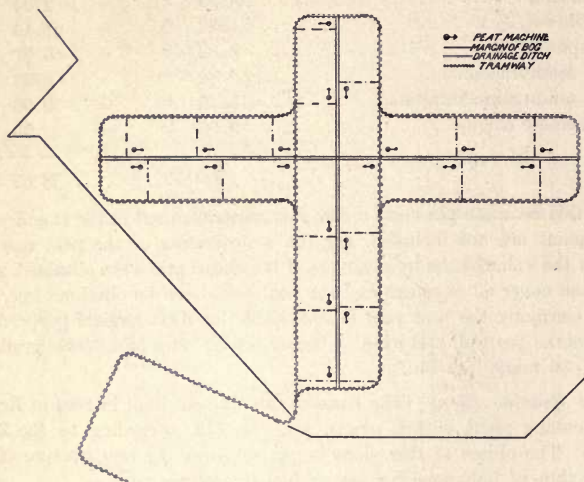


FIG. 180—Peat Bog at Redkino, Russia.

The following results of a test of 45 days duration on four twin retorts were given by J. Karischew, director of the plant.\*

1. The non-condensable gases produced, both when making peat coke and half coke, are quite sufficient to heat the retorts.

2. The daily capacity per oven is a little higher when manufacturing peat coke, and a little lower when manufacturing half coke, than was claimed by the inventor (19.8 and 29.7 tons air-dried peat respectively).

3. Of the weight of the peat used 36% was obtained as peat coke, and when manufacturing half coke, 44–48%, depending on the content of moisture in the peat.

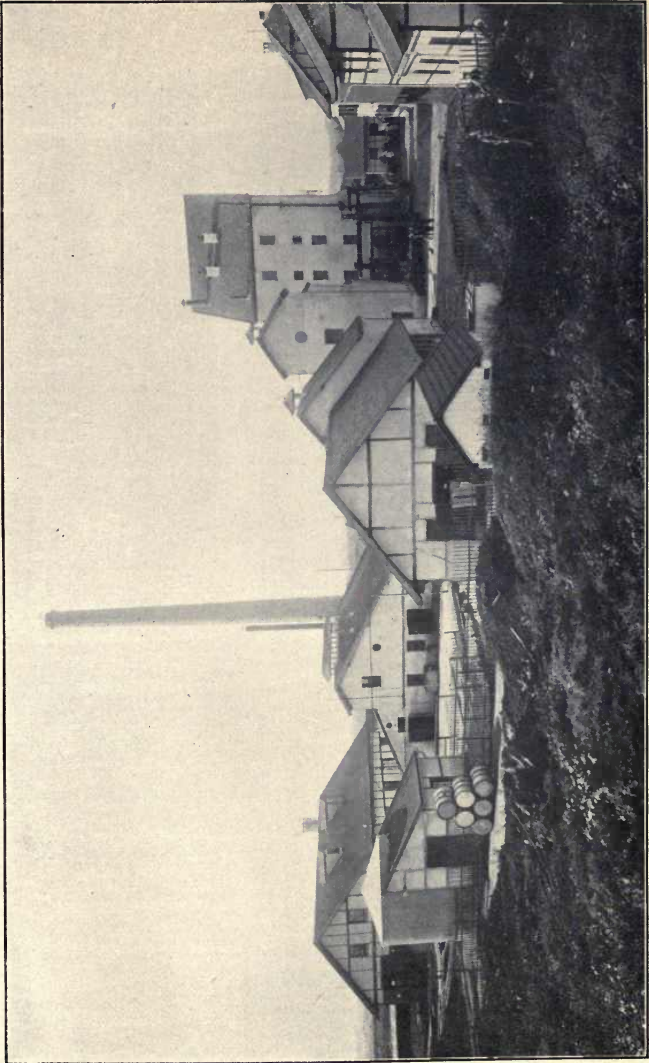
4. The results obtained demonstrated the fact that with low prices on the by-products the value of these still paid all expenses and the coke and half coke were obtained free.

The amount of tar and tar water obtained when manufacturing half coke was 4.34% and 29% respectively.†

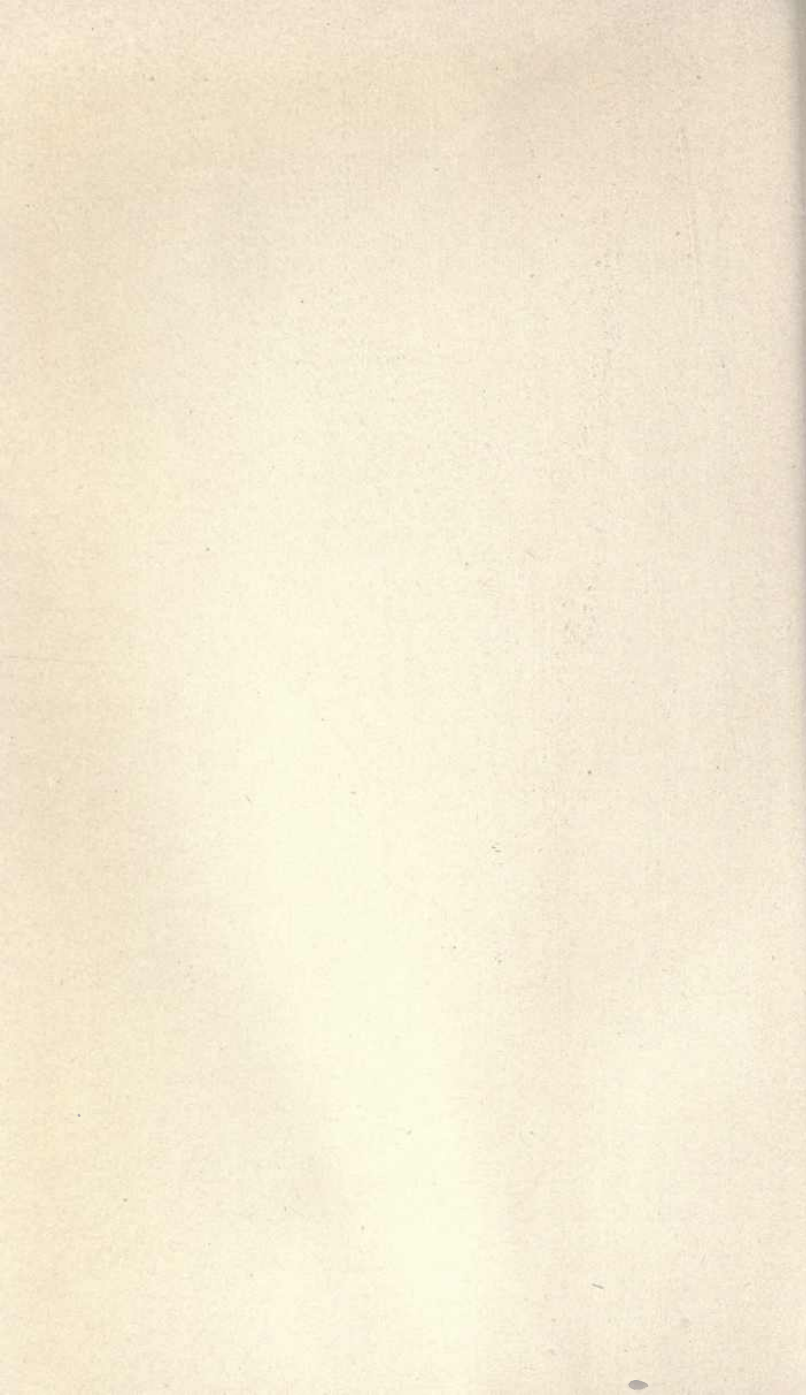
\*Hausding.

†According to Larson and Wallgren.

PLATE 30.



Peat Coking Plant at Beuerberg, Germany.





The tar water contained:

Methyl alcohol . . . . .	0.40%	
Acetic acid . . . . .	0.80%	—corresponding to 1.25% acetate of lime.
Ammonia . . . . .	0.85%	—corresponding to 3.30% ammonium sulphate.

One pound half coke burnt under a stationary boiler evaporated 6.63 lbs. water, and in a locomotive boiler 5.76 lbs.

In the stationary boiler with different fuels the following results were obtained:

1 lb. wood . . . . .	produced	3.24 lbs. steam
1 lb. Russian coal (Don) . . . . .	“	6.67 lbs. “
1 lb. briquetted coal . . . . .	“	7.10 lbs. “
1 lb. peat half coke . . . . .	“	6.63 lbs. “

*The Beuerberg plant.*—This plant is the latest and most up-to-date peat coking plant so far erected.

The bog at which the plant is located and the methods used for working same are already described on pages 112–113.

The coking plant consists of two twin ovens for the manufacture of peat coke, two half coke ovens, and a complete by-product plant. A general plan of the works is shown in Fig. 181 and a view in Plate 30.

The peat bricks used have a content of moisture of 20–25%, and lately Mr. Ziegler has worked out a process by which the heat contained in the waste gases from the ovens can be utilised for a preliminary drying of the peat bricks. The process is thereby made more independent of weather conditions and the output and quality of the coke improved.

The ovens are in principle similar to those shown in Figs. 176–178, and deliver in 24 hours on an average 8.8 tons of peat coke per oven.

The two half coke ovens consist of circular retorts, about 40 feet high, in which the peat is directly heated by the waste gases from the coke ovens.

Each oven produces in 24 hours about 13–15 tons half coke:

*By-product plant.*—

The tar and tar water, condensed in the pipe condenser, are collected in a large basin placed below the floor of the first room in the tar water distilling building (B). From here it is pumped into tanks placed some 20 feet above the floor of the second room where the tar is separated from the tar water. The latter runs direct into an apparatus where it is treated with lime and the acetic acid recovered as acetate of lime.

The ammonia and methyl alcohol are collected together and treated with steam; the volatile ammonia is treated with weak sulphuric acid and is obtained as ammonium sulphate, and the methyl alcohol as 36% raw methyl alcohol. The solutions of acetate of lime and ammonium sulphate are dried in the vessels described on page 178. The methyl alcohol is refined to 96% alcohol in the third room of the building. In this room are also placed a large water tank and a filter apparatus, by means of which the bog water is cleaned.

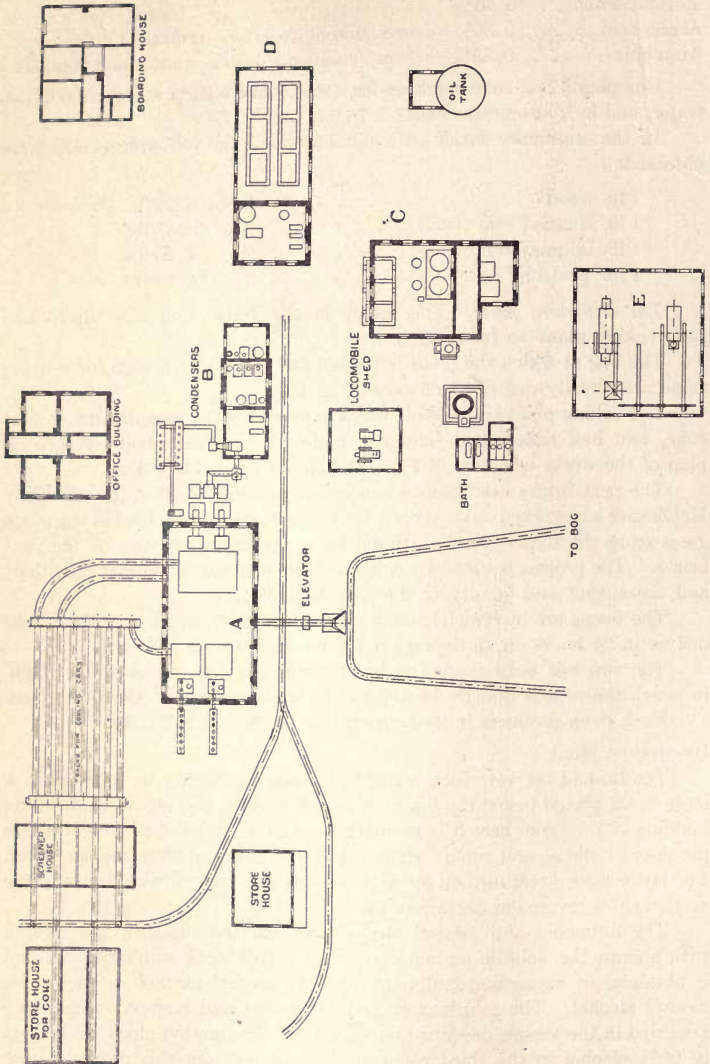


FIG. 181—Peat Coking Plant at Beuerberg, Germany.

A. Coking ovens. B. Building for tar water distillation. C. Building for tar distillation. D. Paraffin plant. E. Electric power station.

The tar separated from the tar water is conveyed by means of a pipe to the distilling apparatus placed in the tar distilling building (C). These apparatus are heated from fire boxes placed in a separate room. The combustion gases escape through a large chimney, with which the flues of two large locomobiles are also connected. Another chimney, some 60 feet in height, is used when the distilling apparatus are cooled by air circulation.

By the distillation of the tar, which is done under 0.8 inches water vacuum, the light oils are first obtained and collected as raw oil, then the lighter paraffin substances, and at last the heavy paraffin substances, which can be used for lubricating purposes.

The coke left is very pure carbon, and is used for the manufacture of carbons and electrodes. The gas developed is forced by means of a vacuum pump through the chimney, or used for heating the distilling apparatus.

In the same building a small experimental plant with a retort capable of coking about 440 lbs. peat, and a distilling apparatus with a capacity of about 220 lbs. tar, is installed.

The lighter paraffin substances are pumped into a large tank placed in a separate building (D), where they are separated from the water which possibly has been condensed. From there they are conveyed to tanks placed in a cooling room, where the paraffin slowly crystallizes.

This process takes about 8 days, and when ready the contents of the tanks are tipped into a mashing apparatus, where the mass is broken up. The solution is filtered off and mixed with the light oils previously obtained, in a large tank. The paraffin scales are washed and dried several times in order to obtain a good product.

*Estimated cost of plant and cost of manufacture.* A 4-oven plant.—The cost of such a plant complete is, according to Dr. Otto K. Zwingenberger (Agent in U.S.A. and Canada), \$100,000, and the working capital required, \$60,000, total \$160,000.\*

\*According to former estimate by M. Ziegler, the different items are in Germany:

Coking Plant: Building .....	39,000 marks.
Brickworks for ovens .....	40,000 "
Iron construction .....	69,000 "
Boiler and apparatus.....	41,000 "
Freight and erection .....	11,000 "
Air drying chambers .....	20,000 "
	<hr/>
	220,000 "
Tar water distilling plant .....	24,000 "
Paraffin plant .....	33,000 "
Peat machines and power station.....	80,000 "
Buildings, etc.....	43,000 "
Working capital.....	200,000 "
	<hr/>
Total .....	600,000 "

The cost of the air-dried peat is calculated by him to be as follows:—\*

156 men (in 2 shifts) at \$1.75 per day. . . . .	\$273.00
12 foremen (in 2 shifts) at \$2.50 per day. . . . .	30.00
	<hr/>
Daily wages. . . . .	\$303.00
7 peat machines at \$1,700. . . . .	\$11,900.00

Assuming that the peat machines are working 100 days during the season, and during that time produce 36,000 tons air-dried peat, the total cost of the peat will be:—

Wages at the peat machines. . . . .	\$30,300
Repairs (3% of the cost of the machine). . . . .	357
Power to run the machines. . . . .	1,200
15 men turning and stacking the peat. . . . .	2,625
15 men for transportation and storing. . . . .	2,625
Loss of interest in 9 months. . . . .	1,400
	<hr/>
Total. . . . .	\$38,507

or per ton peat \$1.08†

A 4 oven plant treats per 24 hours about 100 tons air-dried peat, and with the value of the by-products as given below, the total value of these are:—

900 lbs. ammonium sulphate at. . . . .	\$3.07 per 100 lbs.	\$27.63
1320 lbs. acetate of lime at. . . . .	2.35 "	31.02
65 gallons methyl alcohol at. . . . .	0.70 per gallon	45.50
280 gallons light oils at. . . . .	0.07½ "	21.00
95 gallons heavy oils at. . . . .	0.07½ "	7.12
715 lbs. paraffin at. . . . .	0.03¾ per lb.	26.81
3100 lbs. creosote oil or cabolic acid at. . . . .	0.02¼ per lb.	69.75
440 lbs. asphalt at. . . . .	0.00½ per lb.	2.20
	<hr/>	
Total. . . . .		\$231.03
Deducting 10% for sale expenses. . . . .		23.03
		<hr/>
The actual value of the by-products is. . . . .		\$208.00

\*Assuming that the same peat machines as used at Beuerberg are employed, and that each with 14 men produces 30 tons air dried peat in ten hours, which is probably rather high with these machines.

†This estimate does not include the cost of the bog, its amortization, etc., and general expenses, and unless local conditions are specially favourable, the cost per ton air-dried peat, delivered at the coking plant, is probably nearer \$1.50.

Cost of operating the coking and chemical plant per day.—\*

38 men at \$2 per day . . . . .	\$76.00
2 foremen at \$5 per day . . . . .	10.00
1 chemist at \$8 per day . . . . .	8.00
Sulphuric acid and lime . . . . .	5.00
Int. and depreciation on \$100,000 at 15% . . . . .	42.00
100 tons air-dried peat . . . . .	108.00
General expenses . . . . .	17.50
	<hr/>
Total expenditure . . . . .	\$266.50
Value of by-products . . . . .	208.00
	<hr/>

Cost of 33 tons peat coke . . . . . \$58.50  
or per ton peat coke \$1.74.

Assuming that the air-dried peat costs \$1.50 per ton, the final results are:

Total expenditure . . . . .	\$308.50
Value of by products . . . . .	208.00
	<hr/>

Cost of 33 tons of peat coke . . . . . \$100.50  
or per ton coke \$3.05.

A 12 Oven Plant.—The total cost of such a plant is about \$275,000, and the cost of production in the coking and chemical plant in this case is as follows:—\*

56 men at \$2 per day . . . . .	\$112.00
2 foremen at \$5 per day . . . . .	10.00
1 chemist at \$10 per day . . . . .	10.00
Sulphuric acid and lime . . . . .	15.00
Interest and depreciation . . . . .	126.00
Cost of 300 tons of air-dried peat, \$1.08 per ton . . . . .	324.00
General expenses . . . . .	32.00
	<hr/>
Total expenditure . . . . .	\$629.00
Value of by-products 3 x 208 . . . . .	624.00
	<hr/>

Cost of 99 tons peat coke . . . . . \$5.00  
or per ton coke \$0.05.

Assuming that the air-dried peat costs \$1.50 per ton, the figures are:—

Total expenditure . . . . .	\$755.00
Value of by-products . . . . .	624.00
	<hr/>

Cost of 99 tons peat coke . . . . . \$131.00  
or, per ton coke \$1.32.

\* Some of the figures given referring to labour costs are rather high, and could undoubtedly be somewhat reduced.

In the case of the manufacture of half coke, the cost of the plant is nearly the same as given above, but in such a case, about 45% of the weight of the peat is obtained as half coke.

The economical results of a peat coking plant of the above description are dependent on the prices and market of the by-products produced. These by-products have at present at least in Germany, a ready market and command good prices.

*Bamme's Peat Coking Oven.*—This oven is similar to Ziegler's, but differs somewhat in details. Bamme also uses the non-condensable gases for the heating of his retorts, and saves the by-products. A plant according to his system is in operation at Elisabethfehn, Oldenburg, Germany.

*The Sahlstrom Process.*—\*“In this process the peat is conveyed to a squeezer in which a large proportion of the water contained in the peat is removed by mechanical means.† From this it comes into a tearer, where it is divided into small pieces, and then into a drier. The drier consists of a number of horizontal cylinders heated by means of the waste gases drawn from the carbonizer. The peat is carried through these cylinders by means of screw conveyors, and during this process, becomes still further broken up. The temperature in the drier is not allowed to exceed 150° C. When passing through the drier, the remaining moisture, together with methyl alcohol, acetic acid, etc., is distilled over and collected into condensers by ordinary methods. Owing to the peculiar construction of the conveyors, the peat is not only moved forward in the cylinders, but is constantly kept stirred in such a way that new surfaces are continually being presented to the heat. In this way the maximum result is obtained from a minimum expenditure of heat, so that it is possible to effect all the artificial drying of the material required by what would be otherwise waste gases from the carbonizer and elsewhere.

On leaving the drier the material passes into a revolving screen, where the fibre is automatically removed from the crushed peat.

On leaving the screen the peat passes into a carbonizer where it is partially or fully carbonized, as may be required. The semi-carbonized fuel is more suited for steam raising than the fully carbonized since it gives a greater flame when burning, while, on the other hand, the latter fuel is more suited for smelting ore and for the manufacture of glass, etc. The carbonizer is of somewhat similar construction to the drier, and is fed and worked automatically, while the distilled products, tar, ammonia, combustible and non-combustible gases, are given off in different parts of the apparatus, and are collected, or in the case of the non-combustible gases, are allowed to escape into the atmosphere.

The combustible gases produced in the carbonizer supply all the fuel required for the entire process, as well as power for driving all the machinery,

\*Peat coal and the commercial by products of peat by C. H. Sahlstrom.

†No data as to the amount of water removed in this apparatus are available, and judging from the results obtained with similar apparatus in Europe, it is doubtful if it will work satisfactory.

and since the operations are entirely automatic, the costly element of labour in handling is reduced to that which is required for merely watching the process.

After leaving the carbonizer the peat passes into a cooler, into which it may sometimes be advantageous to lead some of the distilled products such as tar and gas, to be wholly or partially absorbed by the carbon.

After being cooled, the carbon passes into an ordinary briquetting machine, or it may be passed through a disintegrator, which latter machine converts it into a fine powder, which has proved to be the most economical form in which coal fuels can be used for steam raising.

A plant according to this system was some years ago erected at Brockville, Ont., but so far has not been in operation. Any reliable figures as to cost of production and the possibilities of the process can therefore not be had.

*Schöning & Fritz process.*—The first inventor of this process, Schöning, of Stamsund, Norway, pressed the air-dried peat between hot iron plates, under heavy pressure and obtained thereby a partly carbonized product which occupied about  $\frac{1}{5}$  of the volume of the raw peat used. The plates forming the press had to be lifted apart very often in order to allow the gases developed to escape, and the process proved unsatisfactory.

The Deutsche Torfkohlen-Gesellschaft, which had bought this patent, then combined the process with an invention by Fritz, and an experimental plant was erected at Halensee near Berlin, Germany.

Fritz' invention consisted in partly coking the air-dried peat in retorts, only allowing enough gases for the heating of the retorts to be formed.

The process is then carried out as follows:\*

The peat is first passed through a tearing apparatus, and then fed into the uppermost one of three horizontal cast iron retorts. These are provided with screw conveyors, rotating with such velocity that the peat fed in is kept in the retorts about  $\frac{1}{2}$  an hour before it leaves the lowest one of the retorts. At first the retorts are heated with peat fuel, but later with the gases developed. The temperatures in the retorts are 250°, 190°, and 115° C., respectively. The partly carbonized peat mass is conveyed to an iron mould and pressed into briquettes, under 300 atmospheres pressure, with press plungers heated to 200° C. The pressing lasts only about 12 seconds. The briquettes obtained are heavy and strong, do not absorb moisture and burn in a stove with a long smokeless flame, without falling to pieces. The following analyses show the difference in composition of the raw peat and the briquettes†:

\*Svenska mosskultur föreningens tidskrift 1904.

†Hausding.

	Cut Peat from Triangel.		Raw Peat from Reval.	
	Air dried	Briquetted	Air dried	Briquetted
	%	%	%	%
Carbon.....	46.00	69.66	41.49	71.29
Hydrogen.....	4.32	5.40	4.47	4.68
Oxygen & Nitrogen.....	23.91	18.12	29.44	18.00
Sulphur.....	0.16	0.28	0.13	0.21
Ash.....	1.81	5.13	2.24	4.55
Moisture.....	23.20	1.41	23.23	1.27
Calorific value	4057	6793	3460	6651
Calories per kg. }				
B.T.U.....	7302	12227	6228	11972

A plant of the above description has been erected at Carolinenhorst near Stettin, Germany, which has a capacity of 77 tons per 24 hours, with 5 hydraulic presses. The cost of such a plant is estimated to be 300,000 marks, and the cost of manufacture per ton briquettes, including all expenditure, about 9 marks.



## CHAPTER VII.

USES OF PEAT FUEL FOR HEATING, STEAM RAISING AND POWER PURPOSES  
FOR DOMESTIC PURPOSES.

Peat fuel can, as a rule, be used with satisfactory results in any stove where wood can be used, such as for instance, in kitchen and heating stoves.

With heating stoves the results are still better if the stoves are suitably constructed. One of the first suitable heating stoves for peat fuel used in Europe was constructed by A. B. Reck, Denmark, see Fig. 182, and later, several others have been invented.

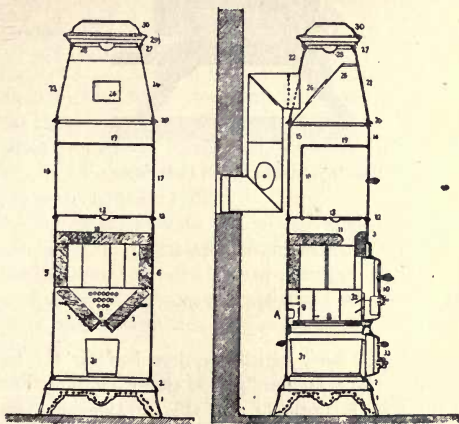


FIG. 182—Rech's Peat Stove.

The one which at present is considered to be one of the best on the market in Sweden is manufactured at Ankarsrum,\* Sweden, in different sizes and with more or less expensive exteriors.

The interior of this stove, see Fig. 183, is lined with special bricks provided with air channels, always insuring a sufficient amount of air for the combustion, and thereby preventing explosions, which are sometimes possible in other stoves, especially if the fuel used contains a great amount of fine dust. The air is by this arrangement preheated, and a higher efficiency of the fuel obtained.

\*Aktiebolaget Ankarsrums bruk.

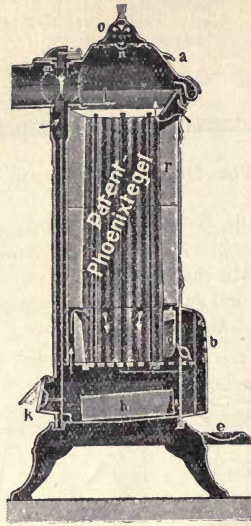


FIG. 183—Ankarsum's Peat Stove.

## FOR STEAM RAISING.

1. *Plane Grates.*

Plane grates for peat fuel, which requires less air for its combustion than coal, should have the grate bars placed closer together than is the case with grates where coal is burned. By this arrangement the amount of unburnt peat particles passing through the grate is greatly reduced.

The distances between the grate bars vary, depending on the quality of the peat used, between 0.32–0.80 inches, and the average height of the peat layer on the grate, between 8–10 inches, in exceptional cases, 12 inches. The height of the fire-box should be at least 24 inches.

The total grate area, when burning 100 lbs. peat per hour, must be at least 5 square feet, and the free grate area  $\frac{1}{3}$  of the total.

If properly attended when using sufficiently dry peat fuel, very little if any smoke is produced, which is an important question in certain localities.

Peat contains, as a rule, very little sulphur compared with coal, and all iron-work which comes in contact with the hot gases is therefore not so quickly destroyed.

The following results are given by Messrs. Larson & Wallgren.  
Boiler test at the sugar factory at Öresund, Sweden.

Fuel	Length of test hours	Fuel per hour & square foot grate area lbs.	Temp. of feed water degrees centigrade	Steam per hour & square foot grate area lbs.	Evaporated water per lbs. fuel lbs.	1 lb. coal corresponds in fuel value to lbs. peat if not mixed with coal lbs. peat	1 lb. coal corresponds in fuel value to lbs. peat if mixed with its own weight coal lbs. peat
Swedish coal (Billesholm).....	7	0.18	83	1.27	7.00	1.38	1.21
English coal (S. York).....	168	0.20	75	1.35	9.40	1.84	1.62
English coal (N. Wales).....	168	0.24	85	2.08	8.40	1.65	1.45
Peat from Löberöd. . . . .	7	0.50	85	2.53	5.10	.....	.....
½ peat* & ½ N. Wales coal.....	6	0.35	85	2.60	7.10	.....	.....

The results show that by mixing peat and coal in the ratio 1:1, the fuel value of the peat in this case is increased some 14%.

In the sugar factory at Karpalund, Sweden, 1 lb. peat evaporated 3.9 lbs. water. In this case the fuel value of the peat, when mixed with its own weight of coal, increased 18%.

In the tube boilers at the sugar factory at Karlshamn, Sweden, 1 lb. peat gave 4.32 lbs. steam of 6—7 atmospheres pressure, and 1 lb. Cardiff coal 7.44 lbs. steam of the same pressure, or 1 lb. coal corresponding to 1.72 lbs. peat.

A number of different tests in various plants where plane grates are used show that 1 lb. of coal corresponds in fuel value to 1.5–1.8 lbs. peat with about 25% moisture.

*Air-dried peat as locomotive fuel.*—Air-dried peat, both cut and machine peat, has previously been used to some extent as locomotive fuel, especially in Bavaria and Oldenburg, Germany. Such peat is, however, bulky, and although no special trouble was encountered in getting up steam and keeping it at sufficient pressure, the use of peat as fuel for locomotives has in Germany steadily decreased. According to Hausding\* the consumption of peat in weight is at least twice as large as that of coal.

In Sweden peat fuel was introduced in 1901–1902 on some of the government railways and the intention was to gradually increase the use of peat fuel instead of coal, at least for slow freight trains. The experiments made demonstrated† that peat fuel could be used without any special changes in the construction of the fire-box, but on account of the bulkiness of the peat, the tender had to be enlarged, and when firing by hand, two stokers were required. One lb. peat produced on an average 3.8 lbs. steam of 11 atmospheres pressure.

\*Page 451.

†By E. von Friesen.

The following table gives the results obtained at some of the runs.

The price of the peat used was 9.10 kronor per ton, English coal 14.40 kronor, and Swedish coal 9.30 kronor.\*

Number of run.	Date. 1902.	Fuel.	Locomotive. Class and Number.	Steam pressure atmospheres.	Diameter of steam ejector. Inches.	Number of Cars.		Weight of train in tons, (not including locomotive and tender).		Fuel consumption, lbs., per 1000 ton miles.	Evaporation per lb. fuel. lbs.	Cost of fuel per 1000 ton miles. kronor.
						Max.	Average	Max.	Average			
1.....	Feb. 6	Peat.....	K ds No. 547	11	3.8	35	34	605	573	214.4	3.92	0.98
2.....	Feb. 5	"	"	"	4.0	31	31	580	580	197.4	3.83	0.89
3.....	Jan. 29	"	"	"	4.2	31	31	573	573	196.4	3.67	0.89
4.....	Jan. 25	"	"	"	4.4	35	30	607	536	220.5	3.60	1.01
5.....	Feb. 8	"	"	"	4.6	35	30	622	549	202.2	3.61	0.92
6.....	June 5	"	mb. No. 651	12	5.2	67	53	1049	881	155.2	3.78	0.70
7.....	June 6	"	"	"	"	62	57	860	849	174.2	3.93	0.80
8†.....	July 26	½ coal and ½ peat....	K ds No. 547	11	4.0	45	41	731	665	110.4	5.15	0.66
9†.....	July 25	½ peat and ½ briquettes of Swedish coal	"	"	"	46	39	712	616	126.2	5.00	....
10.....	Feb. 11	English coal.....	"	"	"	62	50	644	606	126.8	6.66	0.91
11.....	Feb. 15	Coal { 2 parts English, 1 part Swedish.....	"	"	"	32	31	586	583	149.7	5.48	0.95
12.....	July 11	Briquettes of Swedish coal.....	"	"	"	60	47	...	...	...	5.80	....

† During the summer the same locomotive can haul a considerably heavier train than during the winter. The hauling capacity of the locomotive No. 547 was some 550 and 660 tons respectively.

\*1 krona = 27 cents.

*II. Step Grates.*

Step grates are more efficient than plane grates for fuel such as peat, lignite, sawdust, etc.

A step grate, see Fig. 184, consists of a number of grate bars (A) about 4 inches in width, placed like the steps of a staircase, and supported at each end by cast iron plates (B). D are the grate bars. E is a door through which the ashes can be removed. The grate is filled with peat through the opening (C), the air is admitted from the space (H) to the openings between

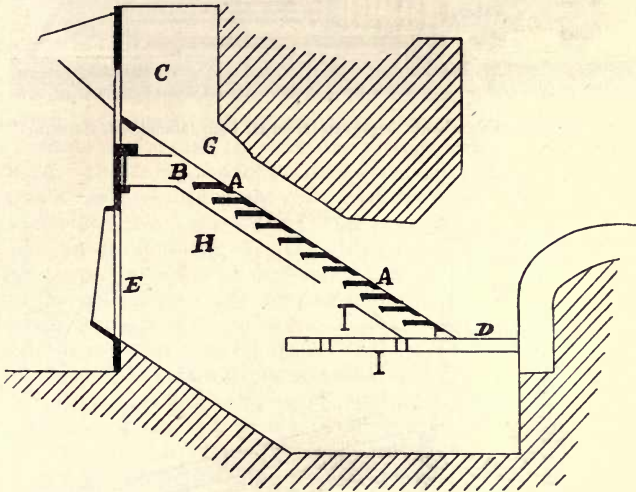


FIG. 184—Step Grate.

the step grate, and as the peat is consumed, it settles down automatically. The opening (C) is usually about half the width of the grate (D). The throat or space at (G) varies from 6 to 8 inches, and the inclination of the grate from 40 to 45 degrees.

Fig. 185 shows a step grate arrangement for a locomobile as manufactured by the well-known firm Heinrich Lanz, Mannheim, Germany.

At Granefors, Sweden, 1 lb. peat produced 4 lbs. steam, at Leistbrau in Munich, 1 lb. peat produced 4.5 lbs. steam, and with Bohemian coal in the same apparatus 1 lb. produced 5.6 lbs. steam.

At Oriechowo in Russia an automatic step grate constructed by Kowalsky is used. This grate, see Fig. 186, has grate bars, of which every second one is movable, whereby the fuel is continuously brought downwards and the grate kept clean from ash and slag. On this grate 1 lb. peat produced 4.1 lbs. steam of 15 atmospheres pressure.

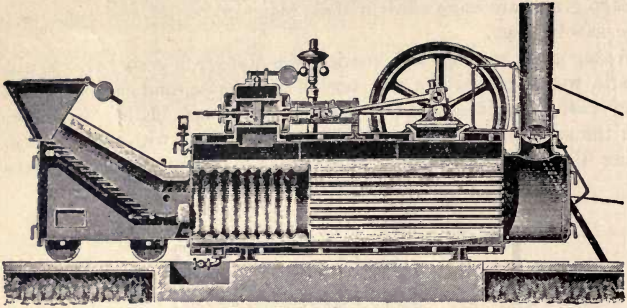


FIG. 185—Locomobile with Step-grate, from H. Lanz, Mannheim, Germany.

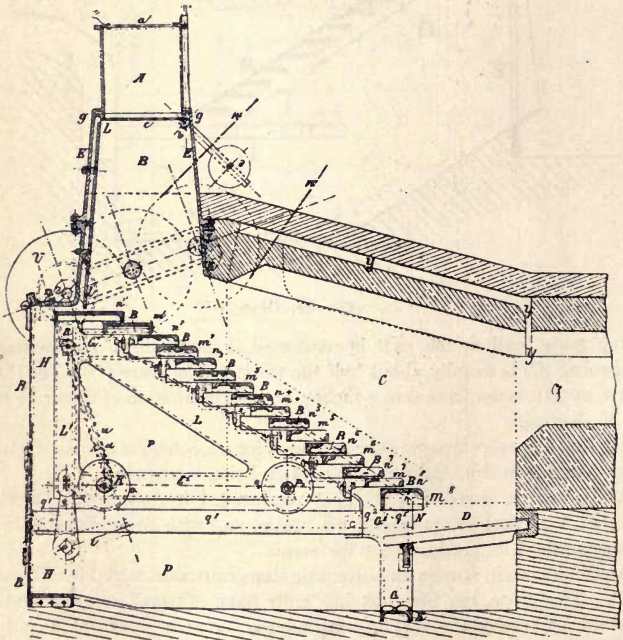


FIG. 186—Kowalsky's Step-grate.

### III. Half Gas Furnaces.

These furnaces have either step grates or inclined plane grates. The air admitted through the grates is not sufficient for the complete combustion of the fuel to carbon dioxide and water, so that mostly carbon monoxide and hydrocarbons are at first formed. These are later mixed with air which is generally more or less preheated, and a complete combustion without smoke is obtained.

A number of such furnaces of different construction are in operation, and as a rule the results obtained are quite satisfactory.

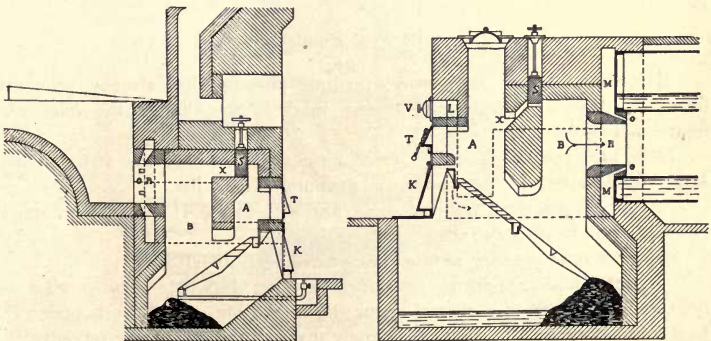
The best known builders of such furnaces in Germany are C. Reich in Hannover, and the firm of Keilmann & Völcker in Bernburg.

Two of the furnaces built by Reich are shown in Figs. 187-188. The fuel is charged through the door (T) or through the hopper in Fig. 188 and falls down on the grate (step, inclined plane grate or a combination of both). It is preheated in the shaft (A) where the moisture and most of the gases are driven off. The air required for the combustion of the fuel to carbon monoxide after it has descended on the grate is let in through the door (K). The gases from the fuel on the lower part of the grate are mixed in space (B) with the gases previously driven off. The admittance of these gases is regulated by the damper (S). The air necessary for the complete combustion is admitted through the valve (V) and passes first through a channel (L) where it is preheated, and at the same time cools the walls. The hot air passes through the holes (O) from the space (M) and is mixed with the hot gases, passing through the burner (R), whereby a smokeless combustion is obtained.

Reich's half gas furnace for peat firing at the sugar factory Papenteich at Meine, gave during tests with peat not quite air-dried a gas containing 17.5% carbon dioxide, and 0.3% oxygen with a draft of 6.5 mm. water. The evaporation per lb. of such peat was 3.42 lbs. water.

Fig. 187.

Fig. 188.



C. Reich's Half-gas Furnace.

At Kulebaki, Russia, an evaporation of 4-4.2 lbs. water per lb. peat was obtained.

Keilmann & Völcker's furnace, see Fig. 189, is of a similar construction. On the upper part of the grates, the fuel is partly gasified, and on the lower, completely. The gases from the upper part of the grate are mixed on their way to the burner with preheated air in the space left by the fixed brick wall and the movable front wall shown in the figure. This front wall can be moved up or down, thereby regulating the amount of fuel let down on the lower part of the grate.

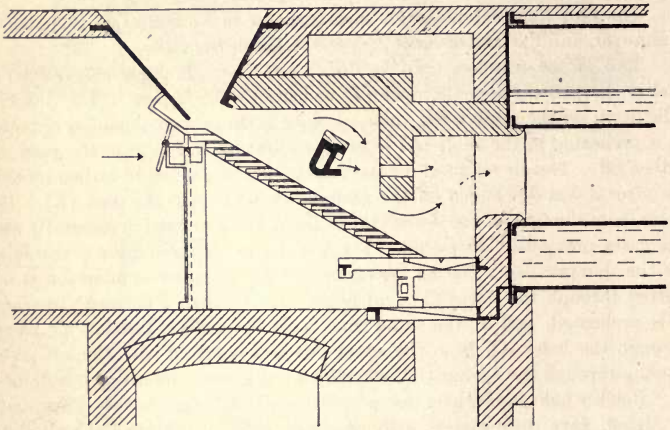


FIG. 189—Keilmann & Völcker's Half-gas Furnace.

Several other furnaces of more or less different construction are in operation, and a great advantage is that peat of poor quality and peat refuse can be used.

#### IV. Peat Powder.

The value of peat powder for heating purposes has already been referred to (pages 171-172) and at a test made in Stockholm\* the following figures were obtained.

1 lb. peat powder with 17% moisture evaporated 5.27 lbs. water in the same boiler where 1 lb. Newcastle coal evaporated 5.67 lbs.

With peat powder 3.5 lbs. of steam and with coal 2.41 lbs. were obtained per sq. foot of heating surface.

Several apparatus for powder firing have been invented.

F. de Camp's apparatus is shown in Figs. 190-191. The powder is delivered by means of a conical screw (C) in the bottom of the hopper (T) to a rotating sieve (D). Here it is finely divided and intimately mixed with

\*Report by Larson & Wallgren, page 338.



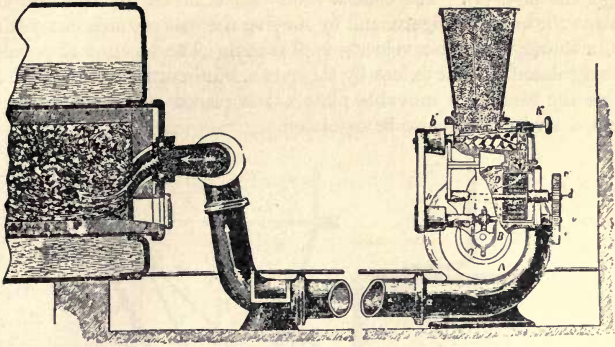


FIG. 190—F. de Camp's Powder-firing Apparatus.

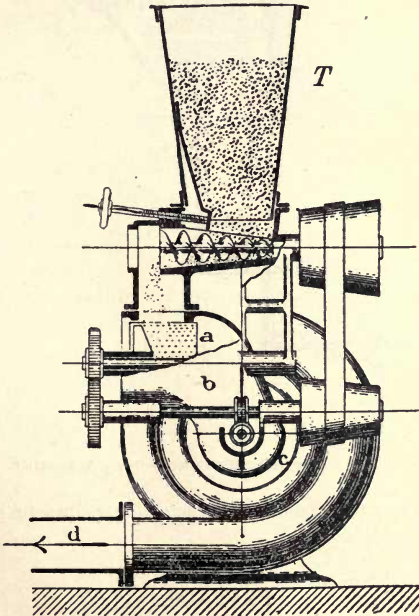


FIG. 191—F. de Camp's Powder-firing Apparatus.

air drawn in by the fan (A) and forced into the fire-box or combustion space through the pipe (a). The conical screw (C) is driven by belt and conical pulleys as shown in the figure, and by moving the belt towards one side or the other, a slower or greater velocity is obtained. The amount of powder fed can be regulated to some extent by this mean, but in order to be able to better regulate the feeding, a movable plate (k) is placed above the screw. The amount of air let in can also be regulated.

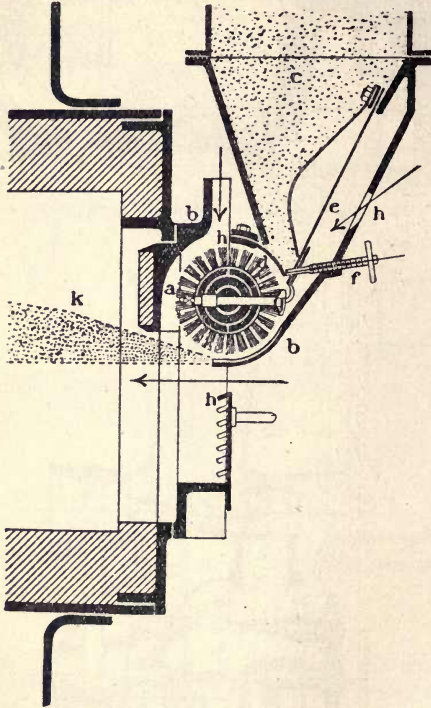


FIG. 192—Schwartzkopf's Powder-firing Apparatus.

Fig. 192 shows an apparatus constructed by Schwartzkopf, and several others could be mentioned.

### PEAT GAS.

Peat is employed at a large number of plants as fuel in producers for the generation of gas, which is used either for heating, or for power purposes.

## A. PEAT GAS FOR HEATING PURPOSES.

The producers used in this case are of the common type; a vertical shaft provided with a plane or step grate at the bottom, and an air-tight feed box on top. The fuel bed is kept at such height, that the carbon dioxide developed, where the air for the combustion enters the producer, is reduced to monoxide on its upward way. Such peat gas is used for firing boilers, and in a number of different industries.

The composition of the gases produced by different fuels is, according to Ebelmen,\* as follows:—

Gases from	Char-coal	Wood		Peat	Coke	Char-coal	Wood		Peat	Coke
		I	II				I	II		
Nitrogen. . . . .	63.4	50.1	50.0	61.5	64.1	64.9	53.2	55.5	63.1	64.8
Carbon monoxide. . . . .	33.3	32.4	19.0	21.8	33.5	34.1	11.6	22.0	22.4	33.8
Carbon dioxide. . . . .	0.5	7.2	13.2	9.1	0.8	0.8	34.5	21.2	14.0	1.3
Hydrogen. . . . .	2.8	10.2	17.8	7.6	1.5	0.2	0.7	1.3	0.5	0.1
	% of volume.					% of weight.				

The loss of heat in the best constructed apparatus for grate firing is some 25–30%, but in suitable gas producers, not more than 15–25%.

A good heating gas contains about:—

- 25% Carbon monoxide,
- 8% Hydrogen,
- 2% Hydrocarbons,
- 59% Nitrogen,
- 6% Carbon dioxide.

and has a calorific value of 123–145 B.T.U. per cub. foot.

By gasifying the dry substance of the following fuels, gases of the following composition are obtained.†

	Peat	Lignite	Coal
CO. . . . .	15%	22%	22%
H. . . . .	10 "	8 "	9 "
CH <sub>4</sub> -C <sub>2</sub> H <sub>4</sub> . . . . .	4 "	2 "	2 "
N. . . . .	57 "	62 "	61 "
CO <sub>2</sub> . . . . .	14 "	6 "	6 "
Calorific value, B.T.U. per cub. foot. . . . .	100% 134%	100% 130%	100% 140%

\*Hausding, page 414, and following pages.

†According to Ziegler.

Showing that a gas can be produced from peat with the same calorific value as that produced from lignite or coal. The peat used contains, however, as a rule, some 20–30% moisture, which decreases the calorific value of the gas, and sometimes necessitates the employment of condensers for the removal of the water vapours. In Sweden the first peat and wood gas producers used for the generation of heating gas, were always provided with condensers, but it was found that very little was gained thereby. By the condensation of the heavy hydrocarbons as well as of the water vapours the calorific value of the gas was diminished and the sensible heat of the gas lost, and it was found that practically the same heating value was obtained when the gas was used without condensation. The water resulting from the condensation was also difficult to dispose of, as it could not be let out in rivers or lakes on account of the impurities it contained.

At plants where the by-products, tar and ammonia (as ammonium sulphate) are recovered, or for the generation of power gas, the question is different.

The thickness of the fuel bed in the producers is with peat 5–8 feet, with lignite or coal 2–4 feet.

In many cases when high temperature is desired, regenerators are used for preheating both the gas and the air used for its combustion.

The general advantages of producer gas firing are:—\*

*a.* By regulating the quantity of gas and air conveyed to the place of combustion, a perfect and uniform combustion is obtained.†

*b.* According to requirements an oxidizing or reducing flame can be obtained, which is of importance to the chemical and metallurgical industries.

*c.* The process of combustion can be limited to a small space, whereby the effect to be attained is frequently reached better and quicker than with direct firing.

*d.* It is possible in every case to utilize perfectly the waste heat by preheating the combustion air or the gas.

*e.* The material to be burned or worked does not come in contact with the solid fuel or ashes, which is of importance for the manufacture of lime, clay products, and metallurgical purposes.

*f.* The attendance is easier, simpler and cheaper than with direct firing.

*g.* The places of the gas production and gas consumption can be separated, thence one producer or a battery of producers can furnish fuel to a large number of furnaces; a long distance between producer and furnace is rather an advantage, as it causes the complete condensation of steam in the producer gas.

*h.* The possibility of burning low grade fuels not suitable for grate firing.

\*Dr. O. Nagel, *Electro-chemical and Metallurgical Industry*, Sept., 1907.

†For the combustion of the gas only a very slight excess of the air, theoretically required for the combustion, needs to be used. With grate firing about twice the required amount of air is often employed.

*For boiler firing.*—At Karpalund's sugar factory, Sweden, two Cornwall boilers were fired with peat gas. The results obtained were 4–4.5 lbs. steam per lb. peat with 18% carbon dioxide in the gas.

In Russia, with J. A. Stroganow's producer, 1 lb. peat produced 4.86–5 lbs. steam.

*In the iron and steel industry.*—Peat has been used for many years in Sweden and in certain parts of Germany and Austria for the generation of gas for open hearth and reheating furnaces. At certain plants peat is used exclusively, but at others a mixture of peat, wood and coal or peat and coal are employed.

A common type of the producer used in Sweden, constructed by Prof. Odelstjerna, is shown in Fig. 193.

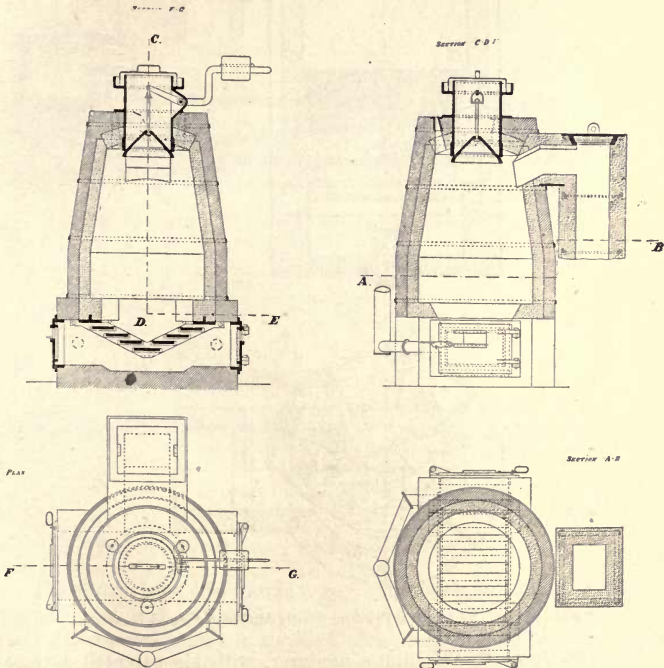


FIG. 193—Peat Gas Producer at Kohlsva Iron Works, Sweden.

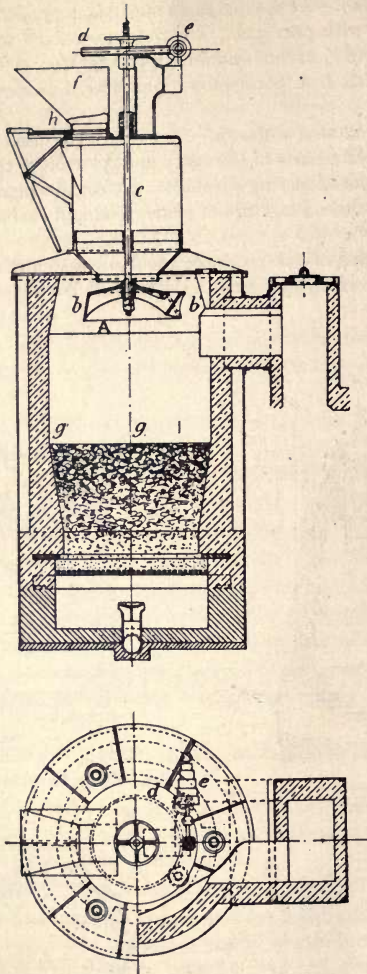


FIG. 194—C. W. Bildt's Producer with Automatic Feed Device.

Fig. 194 shows C. W. Bildt's producer, with his patented automatic feed-device. This producer is used at quite a number of plants in Sweden and the United States. It is in most cases fired with coal, but peat can also be used. The fuel is continuously and uniformly distributed over the charging area, and a gas of uniform quality is obtained.

The composition of the gas produced was when fired with

	Peat	Coal
Carbon dioxide.....	3.4%	1.3%
Oxygen.....	0.3“	0.4“
Carbon monoxide.....	30.7“	29.1“
Hydrogen.....	12.8“	10.6“
Methane.....	7.0“	5.8“
Nitrogen.....	45.8“	52.8“

Fig. 195 shows Bildt's producer combined with a reheating furnace. .

Fig. 196 shows a reverberating furnace fired with producer gas.\*

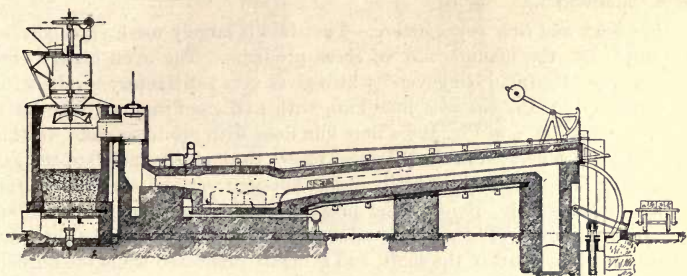


FIG. 195—Bildt's Producer combined with Re-heating Furnace.

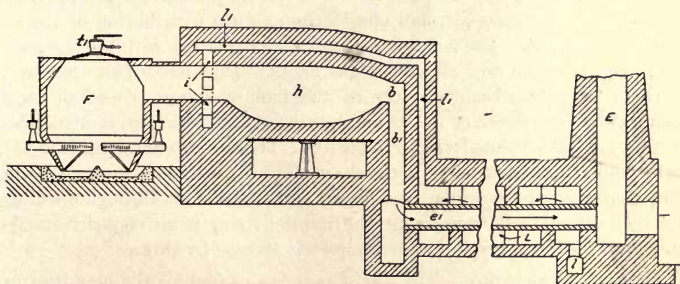


FIG. 196—Reverberatory Furnace, Fired with Producer-gas.

“The change from direct firing to gas firing consists mainly in the addition of the gas producer† and recuperator between furnace and chimney. The recuperator consists mainly of a system of fire clay pipes (e, l) which connect the flue (b) with the chimney (E). This pipe system is built into a wider channel (L) in which the air required for the combustion of the producer gas is intro-

\*Electro-chemical and Metallurgical Industry, Sept., 1907.

†In this case, the Herrick producer, manufactured by the Industrial Gas Co. of New York.

duced at (1). The air passes through channel (L) around the pipe system, (as shown in the figure by arrows) absorbs the heat of the escaping gases, and carries the heat back to the furnace through the channels and openings (i). These channels are connected with the hot air chamber (L) of the recuperator, by air slits or air channels (l'). In these air slits which are arranged throughout the width of the furnace arch, the air is brought to a still higher temperature. Thus at the fire bridge hot producer gas is mixed with hot air, causing a perfect combustion. In working with a reducing flame, the combustion is nearly smokeless. It gets perfectly smokeless by the use of a slight excess of air.

A saving is effected by the higher temperature obtained by the recovery of the heat in the recuperator, by reducing the radiation of the fire place, by the exact regulation of the firing, by the perfect combustion and by the longer life of the firebrick."

*For brick and lime manufacture.*—Peat fuel is largely used, especially in Germany\* for the manufacture of these products. The oven mostly employed is the "Hoffman Ringoven" which gives very satisfactory results with peat firing. Fig. 197 shows a lime kiln, with half gas firing, suitable for a smaller production, and Fig. 198 a lime kiln fired with producer gas. In this latter† the gas generated in the producer passes through channel (f) to the gas distributing flue (g), from which it passes through vertical channels to the gas inlet openings (i). Being under pressure, the gas is equally distributed over the entire area. The air for combustion enters at (d'), absorbs the heat stored in the lower part of the shaft, and is highly preheated while the burned material is cooled at the same time. The air arrives (on account of the high temperature) at the place of combustion at a certain pressure, which prevents the drawing in of excess air, and effects the uniform distribution of the air as well as of the gas. The combustion of the producer gas with the hot air is taking place between and above the gas inlets. That part of the producer gas, which rises upward immediately at the inlet openings, does not meet the amount of air necessary for its combustion, which, however, is introduced above the gas inlets through the air inlets (o). This air enters the shaft at (1), rises through (m,) is distributed in the channels (m,n) behind the firebrick lining of the combustion zone proper, and finally enters the shaft through openings (o). By means of this arrangement, the firebrick lining is air cooled from the outside and the rising producer gas completely burned by this air.

*For glass manufacture.*—The use of peat gas as fuel for the manufacture of glass is, according to Hausding, superior and cheaper than other fuels such as wood and coal, a saving of 30–40% in the fuel cost being obtained.

#### B.—GAS FOR POWER PURPOSES.

In later years the question of gasifying the fuels, and utilizing the gas in gas engines, has received considerable attention. The efficiency

\*Hausding, page 434.

†Electro-chemical and Metallurgical Industry, Sept., 1907.



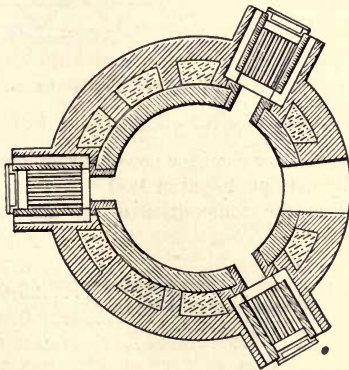
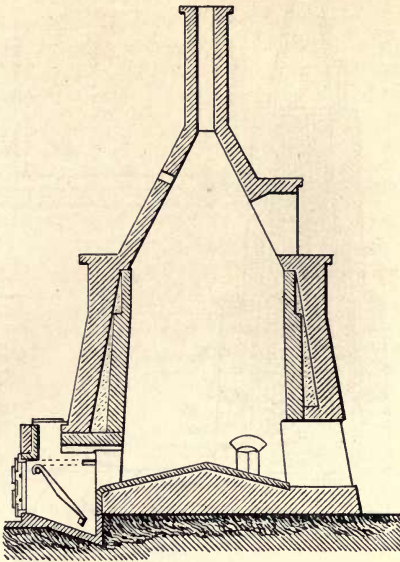


FIG. 197—Lime Kiln with Half-gas Firing.

of the fuel used is thereby considerably increased and the quality of the fuel is not so important, permitting lower grade fuels to be used advantageously.

A gas engine plant utilizes some 20–25% of the calorific value of the fuel, and a steam engine plant only some 8–15% or less.

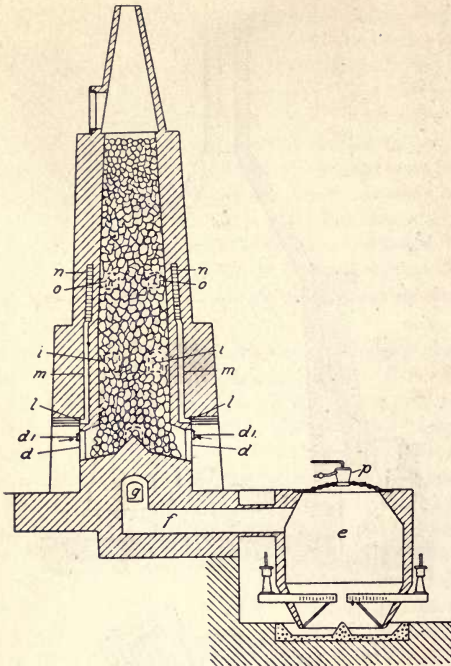


FIG. 198—Lime Kiln Fired with Producer-gas.

#### PRODUCERS FOR NON-BITUMINOUS FUELS.

The first practical producer plant for power purposes was constructed by Dowson, and his results were published in 1881.\*

According to Dowson, the composition of the gas produced with anthracite was as follows:—

CO <sub>2</sub> .....	6.57%	(of volume)
CO.....	25.07	"
CH <sub>4</sub> .....	0.31	"
C <sub>2</sub> H <sub>4</sub> .....	0.31	"
H.....	18.73	"
O.....	0.03	"
N.....	48.98	"

Dowson's idea was taken up and further worked out by most of the gas engine manufacturers, and the plants were generally called *Dowson gas plants*. The usual construction of such a plant (as constructed by the Gas motoren-fabrik Deutz) is shown in Fig. 199.

\*Suction gas plants by E. Hubendick *Teknisk Tidskrift*, No. 47, year 1906.

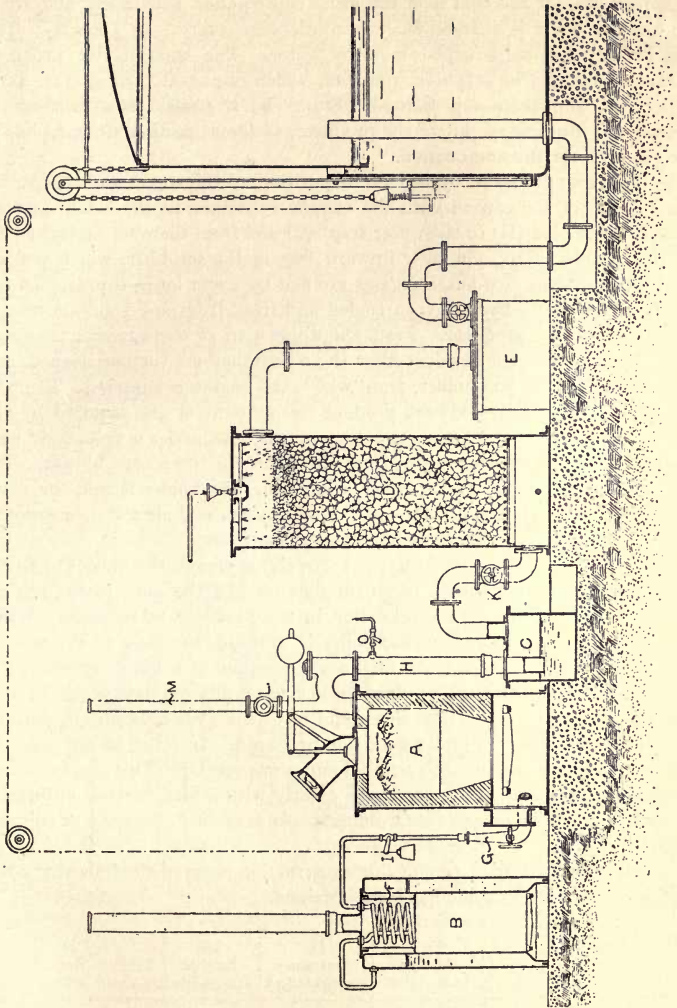


FIG. 199—Dowson Gas-producer Plant (Gas Motorenfabrik Deutz) for Anthracite or Coke.

The principal apparatus are: A producer (A), a small boiler (B), a water trap (C), a scrubber (D), and a sawdust filter (E). The producer consists of a sheet iron shell of circular or square cross-section lined with fire-proof bricks. The layer of coal is carried up by a grate, below which is an air-tight ash pit.

The feed box for the coal is of the usual construction with a movable cone, and the producer is charged at certain intervals (every  $\frac{1}{4}$  or  $\frac{1}{2}$  hours). The top of the producer is kept cooled by water. The small boiler produces steam of about 4 atmospheres pressure, which is passed through the spiral pipes (F), and there superheated. From (F) it passes through a steam blower (G) into the ash pit of the producer, at the same time drawing in the air required for the combustion.

The gases produced by the decomposition of the steam and the partial combustion of the carbon with the oxygen contained in the steam and air pass through pipe (H) to the water trap (C) and from there to the lower part of the scrubber (D). On their upward way in the scrubber, which is filled with coke or laths of wood, the gases are met by water let in through the top of the scrubber. They are then cooled and freed from any solid substances brought from the producer. From the upper part of the scrubber the gases are forced through the sawdust filter (E) where they are further cleaned, and from there into a gas holder, from which the engine is supplied. In order that the producer may always produce the amount of gas required by the engine, and neither too little nor too much, the gas holder is connected with the valve (I) on the steam pipe from the boiler to the steam blower. The connection is made in such manner, that, when the holder is full, the valve is closed, and when it sinks, the valve opens, steam and air are then supplied to the producer, gas is generated and the holder rises.

If the engine is not working the valve (K) is closed, the valve (L) to the chimney opened, the supply of steam shut off and the door to the ash pit opened, when a very slow combustion in the producer takes place. When the producer is again started the boiler is fired up, the door to the ash pit closed and steam put on. At first a gas containing a large percentage of carbon dioxide and steam is produced, which gas is allowed to pass out through the chimney. The valve (L) is closed and (K) opened when the coal in the producer is sufficiently hot and a good gas produced. In order to test the gas, the pipe (H) is provided with a valve and a gas jet (O). This is opened and the gas ignited. When the gas burns quietly with a blue flame if anthracite is used, and with an orange yellow flame if coke is gasified, the gas is of suitable composition.

With different producers of this construction a gas of the following composition and calorific value has been obtained.

	I Belgian anthracite	II German anthracite	III English anthracite	IV Gas coke
CO <sub>2</sub> .....	11.3%	9.0%	7.2%	4.8% (of volume)
CO.....	16.6"	18.2"	26.8"	27.6"
H.....	24.2"	18.2"	18.4"	7.0"
CH <sub>4</sub> .....	2.0"	1.0"	0.6"	2.0"
N.....	45.9"	53.5"	47.0"	58.6"
Calorific value, B.T.U. per cubic foot.....	145	123	150	132

In producer III, 77 cub. feet gas were obtained per lb. anthracite.

One lb. anthracite, with the assumed calorific value of 14,040 B.T.U. per lb. gives consequently by the combustion of the gases 11,550 B.T.U.

The distribution of heat in the producer is as follows:—

Calorific value of the gases.....	11,550 B.T.U.....	82.5%
Pyrometric heat “.....	1,080 “.....	7.7%
Loss through radiation.....	1,410 “.....	9.8%
	14040 “.....	100%

The above description shows that at a Dowson plant the air for the producer is supplied under pressure, and the gas for the engine is also under pressure. In order to accomplish this, a special boiler fired with extra fuel, and a comparatively large gas holder are required. These apparatus make the plant complicated and require a comparatively large space. The small efficiency of the boiler has also a bad influence on the efficiency of the plant as a whole.

In order to simplify the Dowson plants and also make them suitable for small engines, the plant shown in Fig. 200 was constructed by *Bénier*, about 1894.

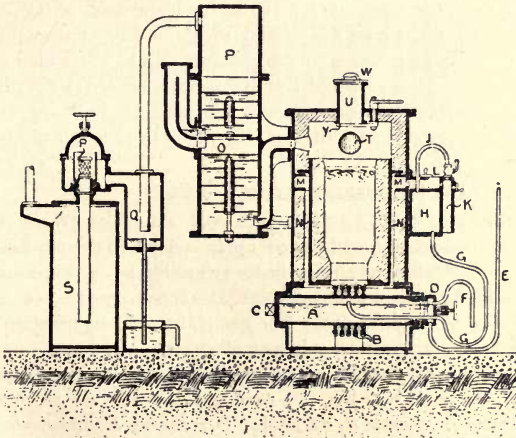


FIG. 200—Bénier Gas-producer Plant for Anthracite or Coke.

His producer consists of an exterior iron shell lined with bricks, and an interior iron shell lined with fire proof bricks, which latter constitutes the producer proper. In the ash pit is placed a hollow iron cylinder (A), which serves both as boiler and grate. The middle part of the cylinder is provided with flanges (B), which carry up the coal layer in the shaft. The mixture of steam and air used for the combustion enters the producer between the

flanges. At certain intervals the cylinder (A) is turned by means of the tap (C) a quarter of a revolution, when the projecting teeth on the flanges (B) bring the ash down in the ash pit. The ash can also be removed, if required, through a door on the side of the ash pit, without any interruption in the generation of the gas owing to the fact that the air is not forced into the producer, but drawn through the same by the engine. On one side of the cylinder (A) is placed a front piece (D) through which are inserted the feed water pipe (E), the overflow pipe (F) and the steam pipe (G). The front piece (D) is attached to the side of the ash pit. The steam formed passes through pipe (G) to the cylinder (H) and from there through pipe (J) to the cylinder (K) which is open at its lower end.

When the engine draws the gas, a partial vacuum is developed in the producer, air is admitted through the opening (L), and steam from (K) through the opening between (K) and (L). The air and steam are mixed and drawn into the ring-shaped space (M), and pass from there through the narrow cylindrical space (N) where they are preheated, into the ash pit and finally into the producer. The gases developed pass into the cylinders (O) and (P). These cylinders are partly filled with water, and provided with plates placed in zigzag. The gases are thereby forced to travel a long distance and are cleaned and cooled by the water. The water is let in through the top part of the cylinder (P) and runs from the lower part of (P) to the upper part of (O). The gases pass from (P) to (Q), where any water, which possibly is brought along, is removed and from there through the strainer (R) to (S) which serves as a pressure equalizer. Any gas holder proper is not included in the plant.

When the producer is started, a fan is used to draw the air through. The gases first developed pass through the pipe (T) through the fan and out in the chimney.

The charging of the producer is done as follows:—

When the cylinder (U) is filled with coal, the cover (W) is put on, the bottom (Y) turned around, and the charge falls down in the producer.

By this construction no special boiler or gas holder are necessary.

A few years later, a similar producer, also for anthracite, was constructed by *Taylor* for a 6–8 h.p. engine. The gas plant was put up close to the gas engine, and the whole occupied only a small space.

The principal parts of this plant which is similar in arrangement to that of a Pintsch gas plant (see Fig. 201 representing a Pintsch gas plant) are:—Producer A, steam generator C, water trap D, scrubber E, and sawdust filter G.

The gas engine is started when the producer is filled with glowing coal, and all the apparatus filled with gas.

The hot gases pass from the producer through the steam producer, which is constructed in the same manner as a tube boiler. Water is let in at its lower end, which gradually absorbs the heat contained in the gases, and in the upper part is transformed into steam. The steam is conveyed by pipe (J) to the ash pit below the grate, where it is mixed with air and drawn through the producer. When a large amount of gas is produced, the amount of steam

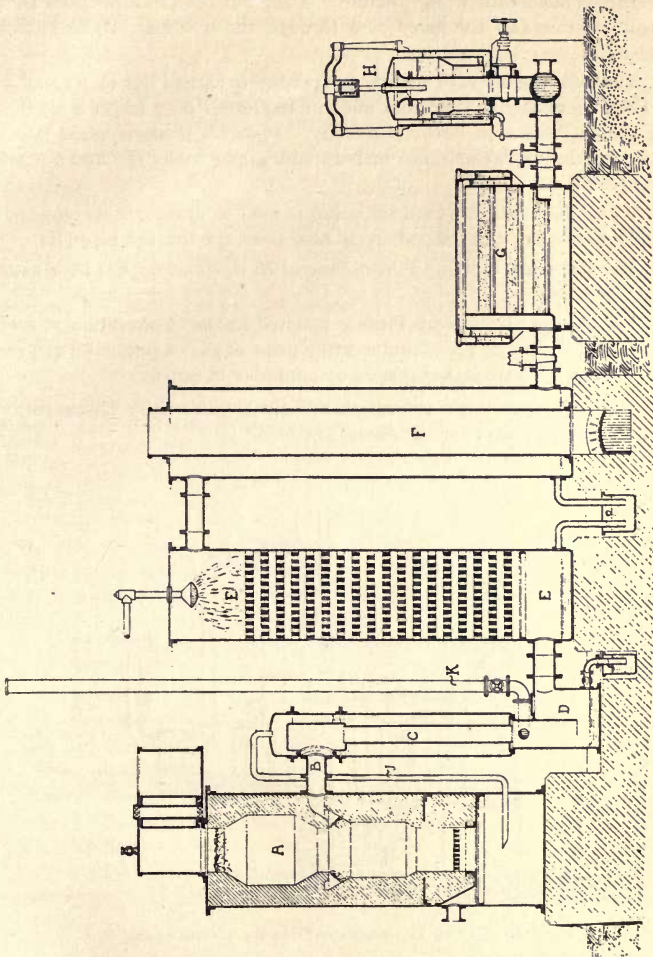


FIG. 201—Pintsch Gas-producer Plant for Anthracite or Coke.

generated is correspondingly large, and when only a small amount of gas is produced, the amount of steam generated is small, so that the amount of steam required is automatically regulated by the producer itself.

The partly cooled gases pass from (C) to (D), which, when the engine is not working, is filled with water, thereby cutting out the producer from the gas circuit. From (D) the gases pass through the scrubber (E) and sawdust filter (G).

The experiments with suction gas producers carried out on a small scale by Bénier and Taylor were continued in 1900–1901 on a larger scale by the firm Julius Pintsch in Berlin, Germany. *Pintsch's producer plant* (see Fig. 201) is similar to Taylor's, but includes also a ring cooler (F) and a pressure equalizer (H).

When the producer is started a fan is used to draw in the necessary air, and the gases at first developed are allowed to escape through pipe (K).

The first plant built by Pintsch was of 75 h.p. and worked satisfactorily from the start.

The success attained by Pintsch resulted in the construction of suction gas plants by most of the manufacturing firms of gas engines, and at present suction gas plants are manufactured by a number of firms.

Fig. 202 shows the construction of Gebrüder *Körting's* Hannover, Germany, power gas plant for anthracite and coke.

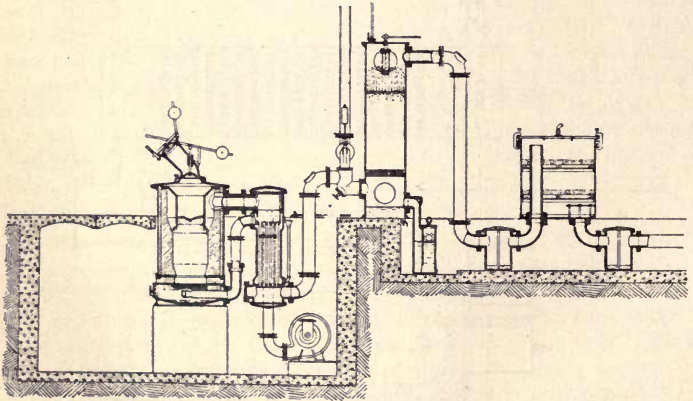


FIG. 202—Körting Gas-producer Plant for Anthracite or Coke.

The fuel consumption with the suction gas plants is some 20% less, the attendance is easier and the plant simpler and requires less space than with the Dowson plants.



The following table gives some comparative results from electric power plants using gas or steam power during 1905-1906.

Name of plant	Capacity of engine h.p.	Total K.W. hours produced	K. W. hours per lb. coal	K.W. hours produced per mark =24 cents	Consumption of oil per K.W. hour ounces
<i>Germany—</i>					
<i>Gas engines.</i>					
Alt-Rahstedt. . . . .	1 of 65 1 of 25	108122	0.40	43	0.19
Clausthal. . . . .	1 of 100 2 of 60	242535	0.43	49.8	0.15
Gransee. . . . .	2 of 50	76170	0.38	35	0.13
Neurode. . . . .	2 of 80	195348	0.40	48	0.09
Schonberg. . . . .	2 of 40	101738	0.38	37	0.14
Schweiz. . . . .	2 of 80	147565	0.42	43	0.09
Sobernheim. . . . .	2 of 50	157788	0.40	49	0.13
Winnenden. . . . .	2 of 80	166985	0.38	40.5	0.12
<i>Steam engines with condensation.</i>					
Niederbronn. . . . .	1 of 120	65620	0.10	11	0.44
Pansa. . . . .	1 of 250 1 of 150	199599	0.20	29	0.17
Thum. . . . .	2 of 60	78901	0.08	10.8	0.68
Aken. . . . .	2 of 80	142041	0.05	19	0.12

In the plants so far described, only non-bituminous fuels such as anthracite, coke, charcoal or peat coke, can be used, as the gas produced from these fuels is comparatively free from heavy hydrocarbons. On account of the expensiveness of these fuels, and the desirability of utilizing bituminous fuels, such as low grade coals, lignite, peat and wood for power purposes, several producers with the necessary apparatus have in later years been invented.

#### PRODUCERS FOR BITUMINOUS FUELS.

Every fuel consists of carbon and compounds of carbon, hydrogen and oxygen, or  $C + C_xH_yO_z$ .

When the fuel is heated or gasified, the hydrogen combines with carbon to form hydrocarbons, and the oxygen also with carbon to form carbon monoxide and dioxide.

The different hydrocarbons are formed in accordance with the following formulæ:—



If in these formulæ, different values of  $n$  are substituted, different gases are obtained. The higher  $n$  is, the higher is the melting and boiling point of the corresponding hydrocarbon.

If a fuel rich in hydrocarbons (bituminous) is gasified in a producer as constructed for anthracite or coke, the hydrocarbons are driven off, and mixed in the cooling apparatus and scrubbers with the permanent gases from the fuel. The tar, paraffin and water vapours are here condensed. The

water used carries away large amounts of these substances, the coke or material in the scrubbers is coated with same, and the scrubbers are gradually choked. A large part of these condensed substances is also carried away by the gas to the gas pipes and gas engines. The pipes thereby become gradually filled up, and the cylinder and valves of the engine choked.

These conditions necessitated the construction of different producers from those used for non-bituminous fuels; the principal problem being to transform the heavy hydrocarbons in the producer itself into permanent gases.

One of the first producers suitable for bituminous fuels was invented by *Dr. Ludvig Mond*.\*

In this producer, bituminous coal (slack and low grades) is gasified with the addition of large amounts of steam. The nitrogen content in the gas is recovered as ammonium sulphate, and a gas suitable for gas engines obtained.

The Mond producer is employed at quite a large number of plants.

*Producers for lignite briquettes* are manufactured by Gebrüder Körting in Hannover, Gasmotoren fabrik Deutz in Cologne, and by a number of other firms in Germany. Gebrüder Körting had, up to March 16th, 1906,† built 43 lignite briquette producers, representing 4,460 h.p.

This producer is a suction gas producer (when the gas is used for heating purposes and pressure is required, a fan is used to draw the gas from the producer and force it through the pipes to the place of combustion.)

The principal parts of the producer, see Fig. 203, are a vertical shaft about 10 feet in height, with a grate at the bottom and outlet for the gases at about half the height of the shaft. The upper part of the shaft is provided with a chimney, in which a gas burner is built in. The gas burner draws the gases directly from the producer shaft through the openings in a masonry grate. The starting of the producer is done in the same manner as the starting of a common stove, by means of natural draft through the chimney, in which the gases driven off are burnt with air through the gas burner mentioned.

When the producer is heated sufficiently (that is filled with glowing briquettes, from which the hydrocarbons are driven off) the chimney is closed, and the producer connected to the engine. From now on the gas is drawn through the gas outlet placed at the middle of the shaft. The cover of the feed box is left open so that air for the combustion can enter, and further air is let in through the door on the side of the ash pit.

The producer consequently burns from both top and bottom towards the middle. The lower fire naturally has a tendency to burn more vigorously on account of the combustion air there passing right through the grate and the fuel bed to the outlet, without any change in its course. The combustion gases from the upper fire, on the other hand, on account of the protection wall placed in front of the gas outlet, must change their course. By regulating the supply of air admitted to the lower fire, the upper fire and the tempera-

\*The Brunner, Mond Co., 39 Victoria St., London, England.

†Paper by E. Brauss, über Neuere Generatoren-Konstruktionen.

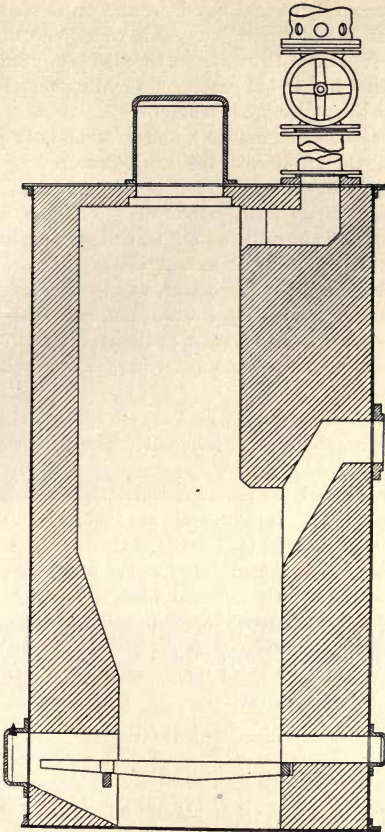


FIG. 203—Körting's Lignite Briquette Gas-producer.

ture developed there can be regulated, so that the right temperature is obtained for the decomposition and combustion of the hydrocarbons driven off from the freshly charged briquettes.

The briquette producer is, on account of its construction, well suited for continuous operation, and the ash and slag formed can be removed easily and without interruption in the work of the producer.

The chemical process in the producer is as follows:—

The process at the lower fire is the same as in a coke producer. The fuel is dried in the upper part of the producer, heated so that the gases are driven off, and coked. The coke is burnt by the air admitted through the grate, to  $\text{CO}_2$ , which is reduced to  $\text{CO}$  on its way to the gas outlet. The ashes

from the briquettes are light and powdery, and on this account the bottom of the ash pit is covered with water. This water vapourizes, and a certain amount of water vapour is then drawn through the producer. The water vapour is decomposed by the hot carbon and hydrogen and CO are formed.

The process at the upper fire is different.

A part of the carbon is here burnt, and so much heat developed that the compounds  $C_x H_y O_z$ , are driven off as hydrocarbons and free oxygen. The oxygen takes part in the combustion, and forms  $CO_2$ . The hydrocarbons are decomposed and partly form carbon and hydrogen, and partly carbon and  $CH_4$ . The carbon is burned to  $CO_2$ , and the hydrogen to  $H_2O$ .  $CH_4$  is a permanent gas which, to a certain extent, increases the value of the gas.

The upper fire is naturally the hotter, as the atmospheric oxygen here is in action, and the fuel bed on top is always so hot, that the  $CO_2$  and  $H_2O$  formed are reduced to CO and H, (part of the  $H_2O$  is derived from the moisture in the fuel.) The gas from the upper part of the producer consequently also contains hydrogen.

By the decomposition of  $H_2O$ , heat is consumed, but by the decomposition of hydrocarbons, the case is different. The hydrocarbons are of two kinds, exothermic and endothermic.

Exothermic hydrocarbons are such which, when decomposed, consume heat, as for instance,  $CH_4$ . Endothermic are such, which when decomposed, develop heat, as for instance,  $2 C_2H_2 = CH_4 + C_3$ .

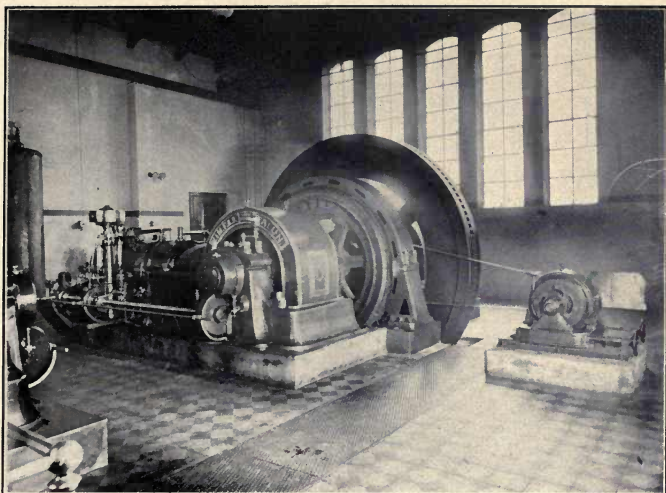
It has been found that the efficiency of the producer as well as the temperature of the gases is slightly different when different briquettes are used. This is explained by the difference in composition of the exothermic and endothermic hydrocarbons contained.

The following table gives some typical analyses of lignite briquettes and the gas produced from same.

BRIQUETTE ANALYSES.

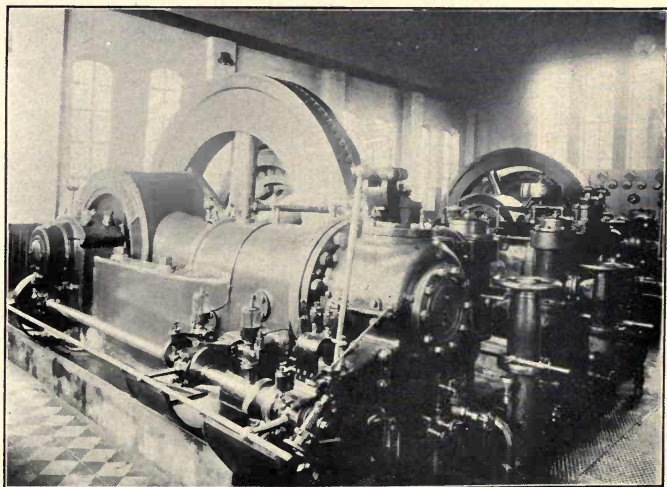
Briquettes from	Moisture	Ash	Slag	H.	C.	O+N	Caloric value B.T.U.
Lauchhammer (Lausitz).....	11.30	5.56	1.04	4.41	49.90	27.79	7686
Bockwitz (Lausitz).....	13.88	4.38	1.09	4.00	53.38	23.27	8244
Union (Rheinland).....	12.81	5.79	1.00	4.55	54.73	21.12	8892
Ilona (Hungary).....	13.92	12.00	1.97	3.73	48.32	19.56	7740
Trendelbusch (Braunschweig).....	15.28	8.82	2.54	5.03	52.05	16.28	9108
Riebeck, Montan (Halle).....	12.14	9.30	2.70	4.86	53.73	17.27	9234

PLATE 31.

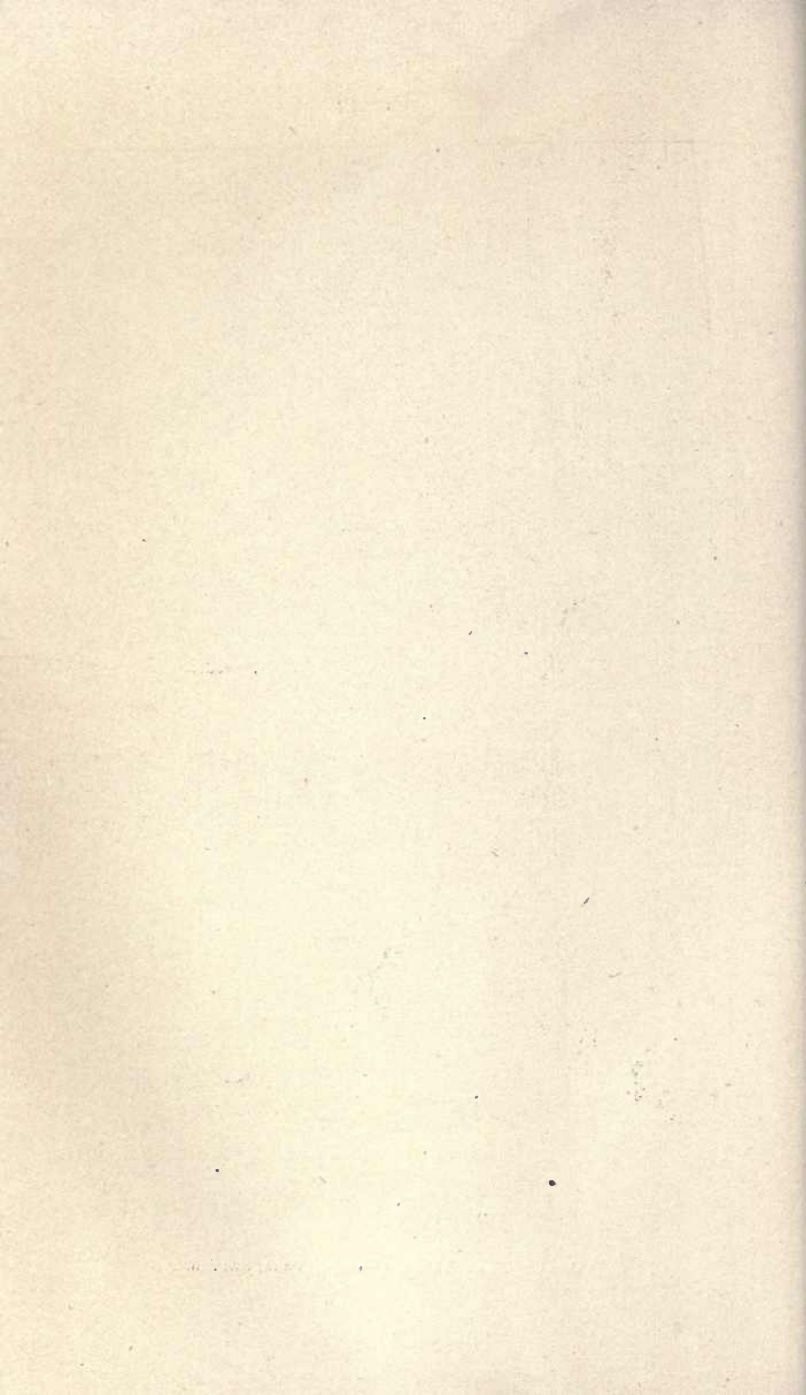


Gas Engine at Skabersjö Peat-gas Plant, Sweden.

PLATE 32.



Gas Engine at Skabersjö Peat-gas Plant, Sweden.



## GAS ANALYSES.

Briquettes from	CO <sub>2</sub>	O	H	CO	CH <sub>4</sub>	C <sub>3</sub> H <sub>6</sub> + C <sub>2</sub> H <sub>4</sub>	N	Calo- rific value B.T.U. per cub. foot
Lauchhammer (Lausitz).....	9.2	0.2	14.9	21.2	1.3	.....	52.9	129
Bockwitz (Lausitz).....	14.8	0.2	16.3	11.8	2.0	0.4	54.3	115
Union (Rheinland).....	8.1	.....	16.2	19.5	2.8	.....	53.4	139
Ilona (Hungary).....	8.6	.....	10.4	19.6	4.6	.....	55.6	142
Trendelbusch (Braunschweig).....	12.2	.....	17.3	15.6	2.4	.....	52.4	128
Riebeck, Montan (Halle).....	10.2	0.2	15.0	18.6	1.5	.....	54.5	123

*Peat Gas Producers.*—Amongst the firms which manufacture peat gas producers, Gebrüder Körting, in Hannover, has erected the greatest number of plants so far in operation. Other firms which also experiment with or manufacture peat gas producers are: Julius Pintsch in Berlin, G. Luther, Braunschweig, and Oberbayerische Kokswerke, Beuerberg in Germany. In England the same question has been taken up by the Power-Gas Corporation, London, and in France by Compagnie de Gaz, H. Riché in Paris.

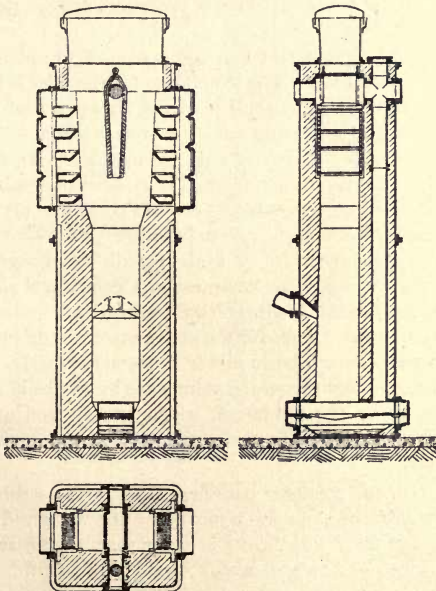


FIG. 204—Körting's Peat Gas-producer.

The *Körting Peat Gas Producer* is a suction gas producer, and consists, see Fig. 204, of a high shaft with a grate at the bottom. The upper part of the shaft is provided with grates on two sides, and with a collector and outlet pipe for the gases developed in the upper part of the producer. A small part of the peat charged falls on the grates and is there burned. The heat thereby developed is sufficient for the drying of the peat, and for the driving off of the gases. Contrary to the briquette producer, in which the gases developed were directly drawn through the fuel bed to the gas outlet, the gases in the peat producer are drawn from the top of the producer through the pipe shown in the figure and pass together with air through the grate at the bottom of the shaft. The hydrocarbons and water vapours are, on their upward way through the hot carbon, decomposed, and the  $\text{CO}_2$  reduced to  $\text{CO}$ . The outlet for the gases is placed a little below the middle of the shaft.

The first *peat gas plant* on a larger scale was erected in 1903 at *Skabersjö*, Sweden, by Gebrüder Körting.\*

The plant is erected close to the Roslätt peat bog, which has an area of 37 acres and an average depth of about 5 feet. The peat is well humified and gives 297 lbs. air-dried peat fuel per cub. yard. The bog contains 44,550 tons peat, which is sufficient to supply the plant with fuel for a period of 30 years. At the end of that time, another bog in the neighborhood containing a peat supply sufficient for some 40–50 years will be worked.

The cost of the peat fuel at the gas producers was in 1904 about \$1.00 per ton.

Fig. 205 shows a section and Fig. 206 a plan of the plant, which has a capacity of 300 electrical h.p. The storehouse for the peat is located close to the producer plant. The plant consists of two units each of 150 h.p. which have both been in operation during the last couple of years.

The machinery is as follows:—2 peat gas producers (1), and 2 scrubbers (2) placed in one room, 2 sawdust filters (3) in a second room, and 2 gas engines (4) with their direct coupled electrical generator (5) and two belt-driven dynamos (6) (exciters) in the engineroom.

The auxiliary machinery is:—2 tanks for the compressed air used for the starting of the engines, 1 air compressor, 1 centrifugal pump to supply the necessary water for the cooling of the engines and the scrubbers, 1 fan for starting the producers, 1 shaft for the above machines driven by an electro-motor, and as reserve a small bezin motor (system Körting).

The peat fuel is brought from the storehouse by means of a conveyor to a large bin placed above the producers, which are charged once each hour. The charging is very conveniently done from the bin, and occupies only a few seconds each time.

The gases from the producer pass first through the scrubbers (2) where any ash particles brought along are removed by the water. The upper parts of the scrubbers are filled with fagots in order that a large area may be obtained. These must be changed about once every month, which requires

\*Through their agents, Engineering Firm Fritz Egnell, Stockholm, Sweden.



Fig. 205.

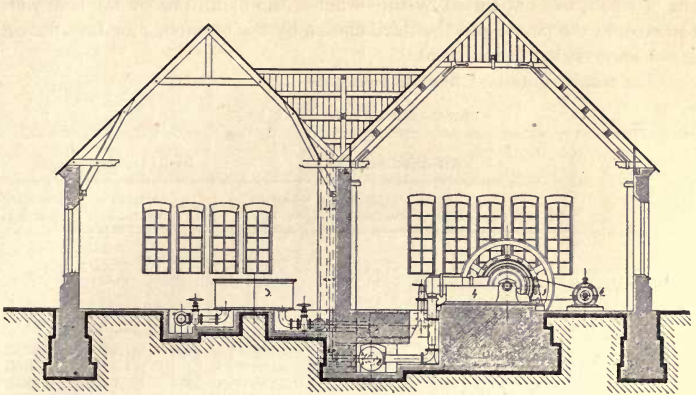
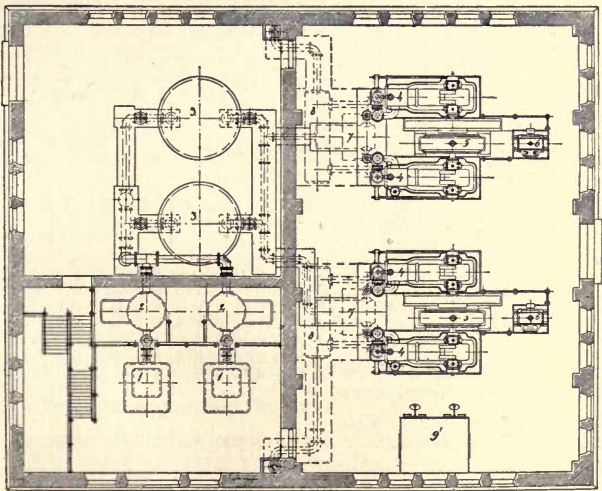


Fig. 206.



Peat-gas Power Plant at Skabersjö, Sweden.

about one hour. The gases pass from the scrubbers to the sawdust filters (3) where water and ash particles still contained are removed. The material used in these filters, sawdust or similar material, is also changed once each month. The gases now pass through a pressure equalizer (7) and to the gas engines.

The gas engines are also of system K rting (see Plates 31, 32) and make 180 revolutions per minute. The electric generators (three-phase) are directly driven by the gas engines, and generate an electric current of 3,000 volts.

During October 7-9, 1906, a commission composed of three members, one of whom was appointed by the owner of the plant, one by the firm which had erected the plant, and the third chosen by the previous members, investigated the working of the plant.

The results obtained were as follows:—

## ANALYSES OF THE PEAT FUEL.

No.	Air-dried sample				Perfectly dry sample		
	Moisture	Ash	Organic substance	Calories per kg.	Ash	Organic substance	Calories per kg.
1.....	34.9						
2.....	35.8						
3.....	36.1						
4.....	33.2						
5.....	35.5						
6.....	35.4	6.16	58.44	2830	9.54	90.46	4990
7.....	30.3	6.84	62.86	3110	9.82	90.18	5000
8.....	28.7	7.81	63.49	3120	10.96	89.04	4895
9.....	35.1	5.61	59.29	2820	8.65	91.35	4945
10.....	31.9	6.02	62.08	3030	8.84	91.16	5005
11.....	29.6						
12.....	29.2						
13.....	35.4						
14.....	30.2						
Average*.....	32.3	6.49	61.23	2980	9.58	90.42	4965

## ANALYSES OF GAS.

No.	1	2	3	4	5	6	7	8	9	10
Vol. %										
CO <sub>2</sub> .....	10.5	10.4	9.4	10.6	9.8	9.0	9.2	9.3	9.7	9.6
CO.....	17.2	18.5	18.8	17.0	20.0	21.5	20.3	19.9	20.2	20.1
O.....	0.9	0.8	1.3	0.9	0.0	0.0	0.0	0.1	0.0	0.0
C <sub>2</sub> H <sub>4</sub> .....	2.8	2.1	1.9	0.4	0.2	0.3	0.4	0.3	0.4	0.3
CH <sub>4</sub> .....	5.2	5.0	5.5	6.0	5.5	5.7	5.2	6.2	6.5	5.3
H.....	6.8	5.8	6.5	6.3	6.5	6.3	6.8	6.0	5.3	6.7
N.....	56.6	56.4	56.6	58.8	58.0	57.2	58.1	58.2	57.9	58.0
(A) Calories per cub. meter, calculated.....	1450	1440	1420	1180	1210	1270	1220	1260	1290	1210
(B) Calories per cub. meter, determined by Junker's calorimeter.....	1180	1170	960	970	1010	1140	1070	.....	.....	.....

Average  $\frac{A+B}{2}$  = 1180 calories per cub. meter, or 132 B.T.U. per cub. foot.

During the trial for the determination of the fuel consumption, gas engine No. 2 was run 6 hours and 11 minutes. The load on the engine was on an average 120 h.p., and the fuel consumption 1,014 kg. peat.

The peat used had, as shown in the previous table, 32.3% moisture with a calorific value of 2,980 calories per kg. (5,364 B.T.U. per lb.)

The fuel consumption per effective h.p. hour was 1.37 kg.=3.0 lbs., and the working of the plant as a whole was found satisfactory.

\*Average of samples Nos. 6-10.

The next plant, shown in Figs. 207, 208, was erected at *Burångsberg*, Sweden, by the same firm.

Fig. 207.

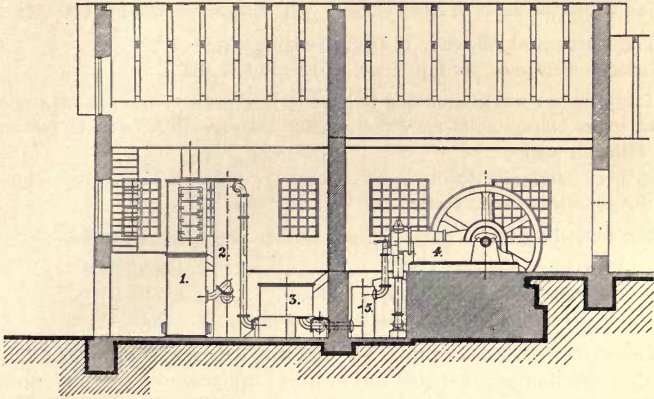
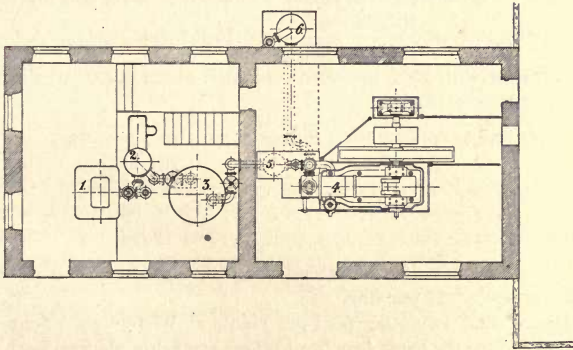


Fig. 208.



PEAT-GAS POWER PLANT AT BURÅNGSBERG, SWEDEN.

1. Gas producer. 2. Scrubber. 3. Sawdust filter. 4. Gas engine. 5. Pressure equalizer. 6. Muffler.

At this plant the gas engine of 60 effective horse power is used for the operation of pumps and hoists in the mine in the vicinity.

A brake test made early in 1904 gave the following results:—

Effective h.p. . . . . . 66.9

Indicated h.p. . . . . . 82.3

Consumption of fuel. . . . . 1.12 kg.=2.46 lbs. per effective h.p. hour.

The peat used contained:

Moisture . . . . .	39.71%
Ash . . . . .	4.38%
Combustible substance . . . . .	55.91%

and had a calorific value of 2,689 calories per kilogram=4,840 B.T.U. per lb.

The mechanical efficiency of the gas engine was 81.3 %.

Calories consumed per h.p. hour, 3,012=11,927 B.T.U.

The producer was guaranteed to have 80% efficiency, and the gas engine guaranteed to consume not more than 2,400 calories =9,504 B.T.U. per h.p. hour with full load.

80% of 3,012 is equal to 2,409 calories, or 9,515 B.T.U., which shows that the guarantees were carried out.

The following results were obtained during two months run:—

Total firing . . . . .	1,464 hours.
Gas engine working . . . . .	1,080 “
Producer kept hot, gas engine not working . . . . .	384 “

The total fuel consumption was 107,800 lbs. peat with about 25% moisture. While the gas engine was idle, but the producer kept hot, about 8.8 lbs. peat per hour were required, or a total of about 3,300 lbs.

The average load on the engine was about 45 h.p., and the consumption of fuel per h.p. hour  $\frac{107,800-3,300}{45 \times 1,080} = 2.15$  lbs. peat.

The peat with 25% moisture contained about 3,600 calories per kg., or 6,480 B.T.U. per lb.

The average consumption during some two years was:

	per day	per h.p. hour
Peat fuel . . . . .	2,354 lbs.	2.18 lbs.
Oil . . . . .	16.06 “	0.0154 “
Cylinder oil . . . . .	12.76 “	0.0132 “

The labour cost for the attendance of the producer and gas engine was on an average \$2.27 per day.

During 1907 two other peat gas plants at Wisby\* and Sunne, Sweden, were erected by the same firm, and others are being planned both in Sweden and Denmark.

The producer constructed by the firm *Julius Pintsch* in Berlin, is shown in Fig. 209. The producer consists of a shaft provided with a cast iron cylinder, acting as a kind of retort in which the bituminous substances are gasified. The gases are by means of a steam ejector drawn from the upper part of the shaft and forced into the lower part, where they are mixed with air. The mixture of air and gas passes through the layer of hot carbon, and are transformed into hydrogen, carbon monoxide and methane.

\*The plant at Wisby will be enlarged during 1908 from 250 to 1,000 h.p.

The producer is said to work well, but peat with higher contents moisture cannot be used.

*G. Luther* in Braunschweig has erected one peat gas plant in Sweden and one or two in Germany. The construction of the producer, which in

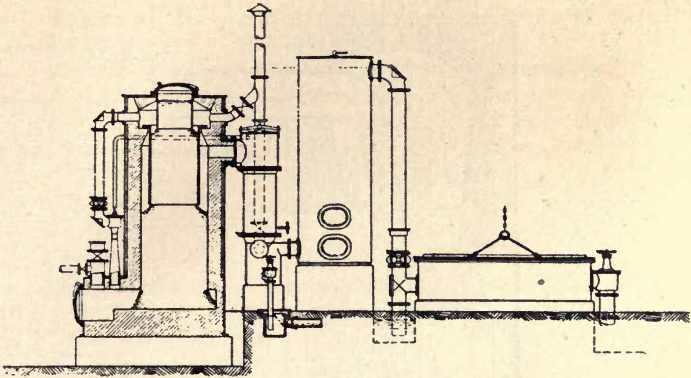


FIG. 209—Pintsch Gas-producer for Bituminous Fuels.

Germany also is used for lignite briquettes, could not be obtained, but at a trial run at *Ofenfabrik Köfner*, in Nymphenburg, with a *Luther* gas plant, a consumption of 2.3 lbs. peat per effective h.p. hour was obtained. The peat used had a calorific value of 5,857 B.T.U. per lb., and the gases produced 114 B.T.U. per cub. foot.

*Oberbayerischen Kokswerke in Beuerberg, Germany (M. Ziegler)*.—This producer,\* see Fig. 210, works on the same principle as a coke or anthracite producer, *i.e.*, the gases produced are not all transformed into permanent gases in the producer, but the tar and paraffin substances are later removed in special cooling and cleaning apparatus. The diameter of the producer shaft is made narrower some distance above the grate in order that the gases may pass through the hotter part of the shaft and not follow the walls, where a larger amount of carbon dioxide would pass through unreduced. The combustion air is introduced below the grates by means of a steam blower.

The producer has a large grate area, 86 sq. feet, and can, according to *Ziegler*, produce 1,694,880 cubic feet of gas per 24 hours.

A plant with this producer is in operation at *Scheleken, Germany*, and the gas produced is said to be free from tar, so that the gas engine works without trouble.

\*According to information received, the construction of the producer has later been modified.

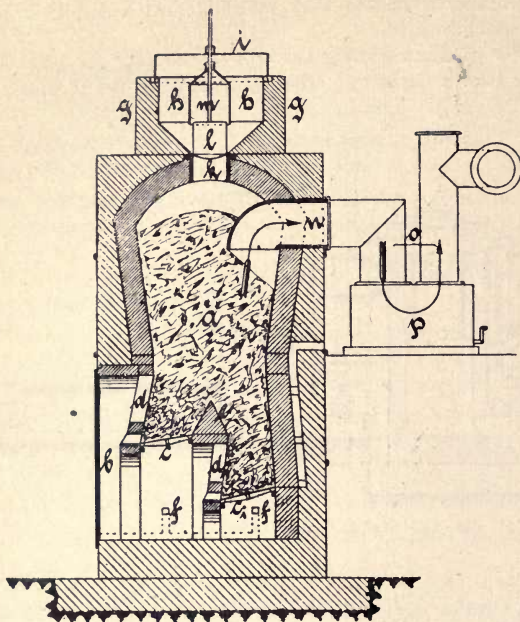


FIG. 210—M. Ziegler's Peat Gas-producer.

The idea with this producer is to recover the by-products, tar and ammonia, contained in the gases before using same in the gas engines.

The same idea has been advocated by *Prof. A. Frank*, Charlottenberg, Germany, and his associate, *Dr. Caro*.

"*Dr. Caro*, on the basis of the Mond process,\* has worked out a new method for gasifying peat in a mixture of air and superheated steam in excess. The process has been tried with Irish peat at the Mond works in Stockton, and it has been found that almost the total amount of nitrogen in the peat is changed and recovered as ammonium sulphate, which can be easily sold as fertilizer.

At the Stockton works the output from 220 lbs. of peat, calculated as free from water and containing somewhat more than 1% nitrogen, was 6.16 lbs. of ammonium sulphate and 8,827 cubic feet of producer gas, with a calorific value of 145 B.T.U. per cubic foot.

*Dr. Caro* gives the following results obtained in tests at Winnington, England, where there is a large Mond gas producer plant. The Mond gas producers which were available there were partly used for gasifying peat.

\**Electro-chemical and Metallurgical Industry*, Oct., 1907.

The peat gas was supplied to the gas engines, which were otherwise operated with Mond gas, and ammonium sulphate was recovered in the same works.

The engineer in charge of the gas engine plant did not know whether he received Mond gas or peat gas, because all gas came through the same supply mains. He did not even find the difference in the operation of the gas engines.

Italian peat was employed in these tests, since they were made in the interest of a projected work in Italy.

715 tons of peat were gasified in the whole. The composition of the dry peat substance was as follows:—

Ash.....	15.2%
Volatile substances .....	43.8 “
Nitrogen .....	1.62%
Total carbon .....	56.3%
Fixed carbon .....	34.2 “

with a calorific value of 10,116 B.T.U. per lb.

The peat was used in different conditions, mostly with an average content of 40% water. 48,047 cubic feet of gas, with a calorific value of 152 B.T.U. per cubic foot, were obtained per ton water-free peat substance.

Besides this there were obtained 107 lbs. ammonium sulphate per ton water-free peat.

The gas was partly used for generating the steam required for the gas producer process, partly for heating the ammonium sulphate solution, and besides this an excess of gas was obtained, giving 480 h.p. hours in gas engines for each ton water-free peat.

In this plant the cost of the treatment of 100 tons of peat (the weight being calculated on the basis of water-free peat) was \$50, including wages (\$1 to \$1.25 per man and day), repairs, etc. Further, for the production of the ammonium sulphate, sulphuric acid, costing \$41.25 (at \$7.50 per ton), was used. Finally, if the amortization is assumed to be \$33.75 (10%), the total cost is \$125.

On the other hand, from these 100 tons of water-free peat, ammonium sulphate to the amount of about \$325 was obtained. This shows a good profit, especially if it is considered that the gas is supplied to the gas engines in absolutely pure condition.”

*Compagnie de Gaz H. Riché*, in Paris, erect gas producer plants constructed as a rule for the gasification of wood, but also suitable for peat.

The wood or peat is charged into a number of vertical cast iron retorts, placed in a furnace, and heated from the outside. The outlet for the gases developed is placed at the lower ends of the retorts (see Fig. 211), whereby the gases are forced through the hot (about 900° cent.) carbon left in the retorts from the previous charge.

The process is also carried out in such a manner that two retorts are coupled together. The gases developed in one retort are then forced through the other, which is filled with hot carbon.

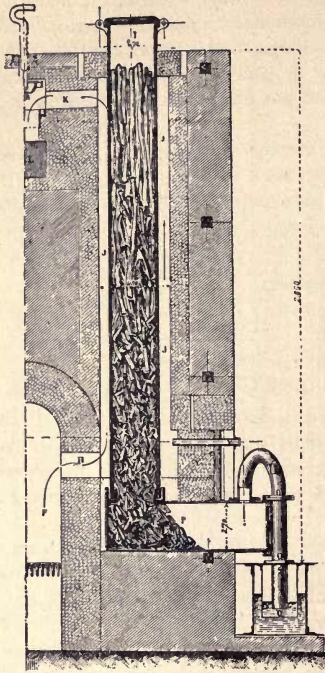


FIG. 211—Riché Gas-producer.

The water vapours driven off from the fresh charge are, when passing through the hot carbon, decomposed, and hydrogen and carbon monoxide formed; the carbon dioxide is reduced to monoxide, and the hydrocarbons transformed into permanent gases.

Fig. 212 show sa Riché gas plant with gas holder.

The retorts are comparatively quickly destroyed, on account of the high temperature required. The pressure in the retorts is 7.2–8.0 inches water, and in the gas holder 0.4 inches.

The gas is used either for illuminating purposes or in gas engines. The composition of the gas is said to be:

CO <sub>2</sub> .....	21% (volume)
CO .....	22% "
CH <sub>4</sub> .....	13% "
H .....	44% "

with a calorific value of 336 B.T.U. per cubic foot.



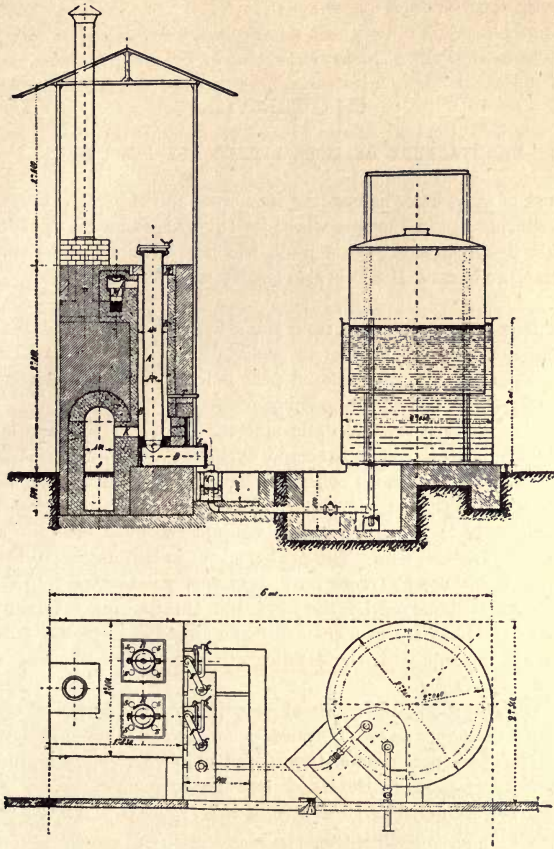


FIG. 212—Riché Gas Plant.

Peat with 30–35% moisture\* gives per 100 lbs. 960 cubic feet gas and 35 lbs. peat coke.

\*Report by Larson and Wallgren.

## CHAPTER VIII.

## MANUFACTURE OF MOSS LITTER AND PEAT MULL.

The use of moss litter as bedding for horses and cattle has in later years increased enormously in Europe, where its advantages for this purpose have been clearly demonstrated. Peat mull, which is obtained as by-product in the manufacture of moss litter, is also largely used for various purposes later described.

Moss litter is manufactured from the sphagnum peat, which must be as little humified as possible in order to be suitable for the manufacture of first class moss litter. Dark, decomposed peat is less suitable, on account of its comparatively small moisture absorbing properties.

A simple, practical test\* to determine the quality of the peat is the following: A piece of the peat is squeezed by hand, and if only clear water is squeezed out, and the remains consist of light coloured undecomposed moss residue, the peat is as a rule well suitable for the manufacture of moss litter.

The digging of the peat is generally commenced in the autumn and continues until the frost sets in. The peat dug out is laid out on the surface of the bog, and left there to freeze until next spring. Contrary to peat fuel, moss litter is not damaged by the frost, but the freezing is advantageous. The fibres in the peat are broken up by the frost, whereby the subsequent drying process is facilitated, the disintegration is made easier and the peat becomes soft and elastic.

By combining the manufacture of peat fuel and moss litter at such bogs, where suitable peat for the two purposes occur, the advantage is gained that the workmen, or at least part of them, can then be given work during the greater part of the year, and the labour question is made easier.

**MANUFACTURE OF MOSS LITTER ON A SMALL SCALE.**—The method used by farmers in many localities for the manufacture of smaller quantities of moss litter for their own farms is as follows:—

The bog, or part of same, is first sufficiently drained, so that a horse can walk on its surface. In the autumn, the surface is ploughed up to a depth of 6–8 inches, and the peat left in this state during the winter. Next spring, when the ground has dried sufficiently, the peat is thoroughly harrowed, and when dried, scraped in heaps, conveyed to a suitable storehouse and used as required. The surface can be harrowed several times during the summer, as the peat dries quickly when it is spread out in a thin loose layer exposed to wind and sun, and considerable amounts of litter can be obtained by this method, which is often used by the farmers in north-western Germany.

\*Om Torströ, by H. von Feilitzen.

In localities where this method cannot be used, or where larger quantities are required, the peat is dug out with spades in brick-shaped pieces, in the same manner and with the same tools as described in Chap. III dealing with cut peat for fuel purposes. The peat is also dried in the same manner, either on the surface of the bog or in special drying sheds, and stacked or stored in storehouses.

**MANUFACTURE OF MOSS LITTER AND PEAT MULL ON A LARGER SCALE.**—The dried peat, after being brought to the plant, is first passed through a tearing machine, or disintegrator, where the fibres are torn apart. During this process, a certain amount of mull is also formed. The product from the disintegrator is therefore, in cases where the mull is separated from the fibre, passed through a sieve, and the two products separated. The litter and mull are afterwards pressed into bales.

*The Tearing Machines or Disintegrators* used are of somewhat different construction, but of the same principle. The machines are made in different sizes; the smaller ones are operated by hand power and those of larger capacity by motor power.

The principal manufacturers of complete machinery for moss litter and peat mull plants are in Germany: R. Dolberg Aktiengesellschaft in Rostock, and A. Heinen in Varel, in Sweden, Abjörn Anderson's Mek, Verkstads A. B. Svedala.

Disintegrators and presses of slightly different construction from those manufactured by the above firms are also manufactured by a number of other firms in both Germany and Sweden.

FIG. 213

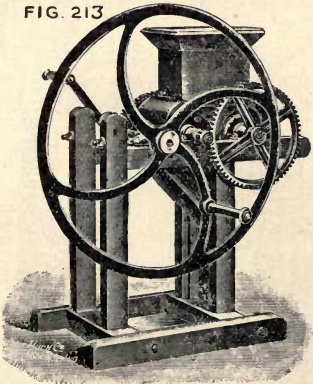
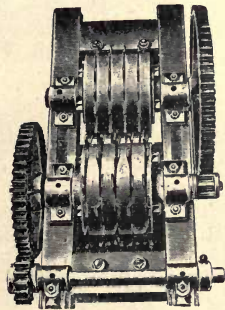


FIG. 214



R. Dolberg's Moss Litter Disintegrator for Hand-power.

Figs. 213, 214 show a disintegrator, for hand power, manufactured by R. Dolberg. This machine consists of two drums provided with teeth, which rotate with different velocities against each other. The teeth on the

drum which rotates with greater velocity are alternately bent as shown in the figures, to right and left. The teeth on the other drum are all in each row in the same plane, and intersect between the bent teeth on the first drum and keep them clean. The price of this machine, f.o.b. Rostock, is 145 marks.

Fig. 215 shows a disintegrator for hand power, manufactured by A. Heinen. The rotating sieve shown in the figure can easily be removed if desired. The price, f.o.b. Varel, is, with sieve, 400 marks, without sieve, 325 marks.

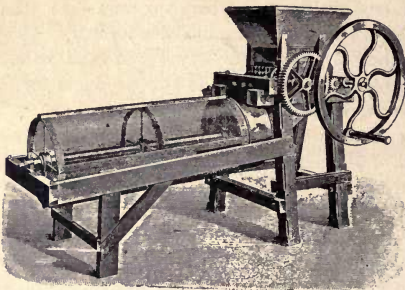


FIG. 215—A. Heinen's Moss Litter Disintegrator for Hand-power.

In Figs. 216–219, a number of disintegrators by different manufacturers are shown. The machines are made in different sizes of different capacities.

In cases where more mull than obtained from the disintegrators is required, special *peat mull mills* are used. These mills can be fed either with the dried peat bricks, or with the litter.

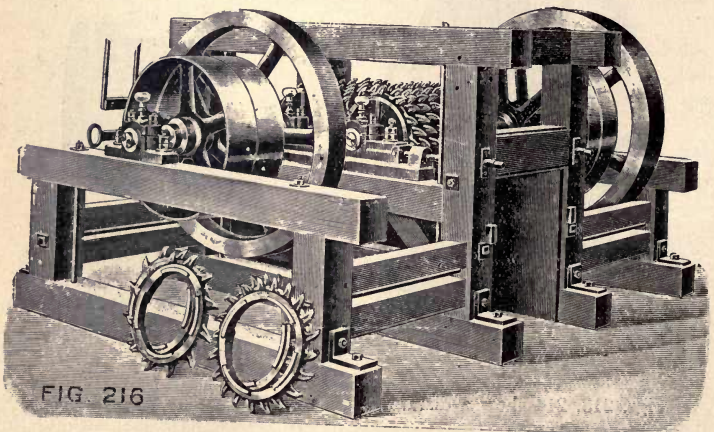


FIG. 216

FIG. 216—A. Heinen's Moss Litter Disintegrator for Motor-power.

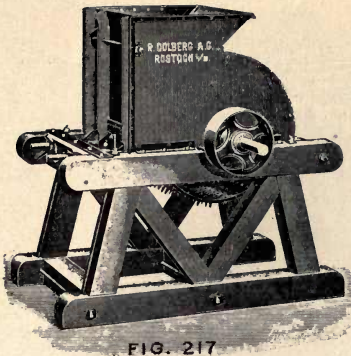


FIG. 217

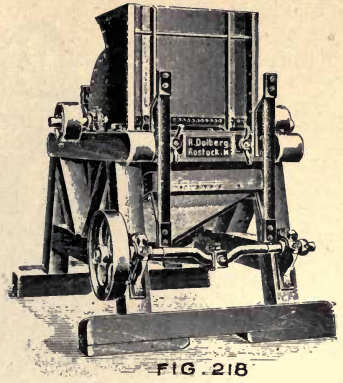


FIG. 218

R. Dolberg's Moss Litter Disintegrator for Motor-power.

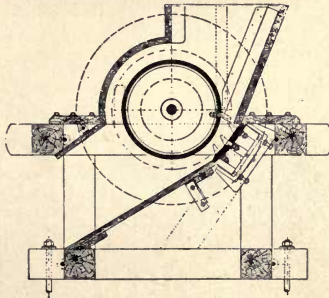


FIG. 219—Abjörn Anderson's Moss Litter Disintegrator for Motor-power.

Figs. 220–222 show different constructions of such mills, which in principle are the same as a common coffee mill.

The presses mostly used are vertical, and strongly constructed of wood. The litter or mull is pressed down to  $\frac{1}{3}$ – $\frac{1}{4}$  of its original volume, and in the presses the bales are secured with 6–10 laths of wood, and bound round with iron wire as shown in Fig. 223.

A press for hand power is shown in Fig. 224, and a press for motor power in Figs. 225, 226.

*Description of the Moss Litter Plant at Yxenhult, Sweden.*—This plant is owned by a co-operative society of landowners and farmers\* in southern Sweden.

\*Skanska Landtmännens Andelstorfströ-förening.

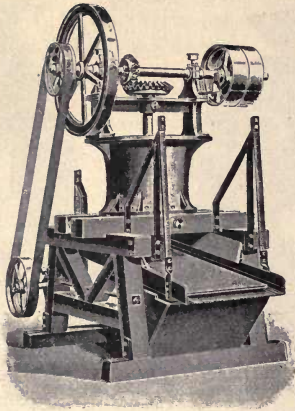


FIG. 220—A. Heinen's Peat Mull Mill.

Fig. 221.

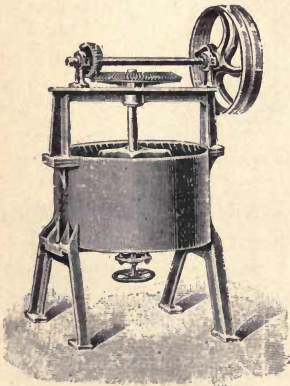
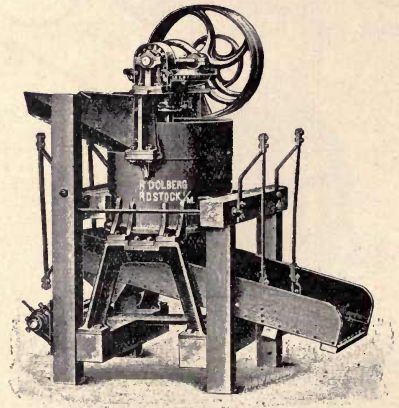


Fig. 222.



R. Dolberg's Peat Mull Mills.

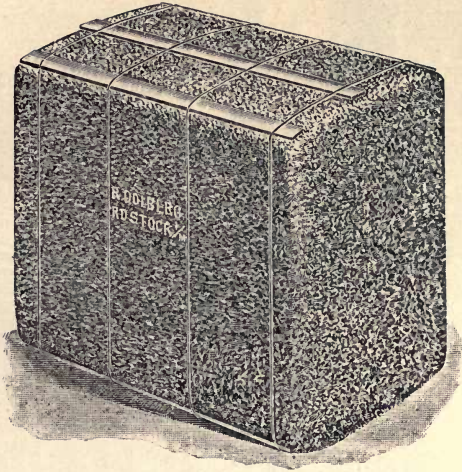


FIG. 223—Moss Litter Bale.

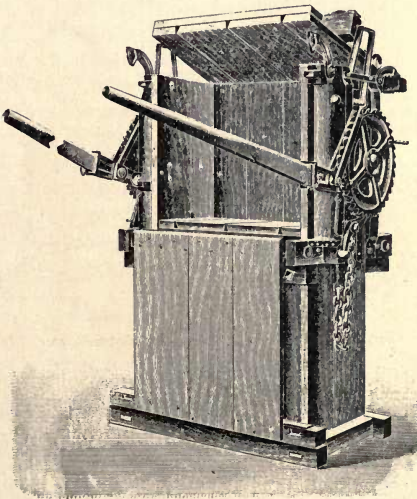


FIG. 224—Moss Litter Press for Hand-power.

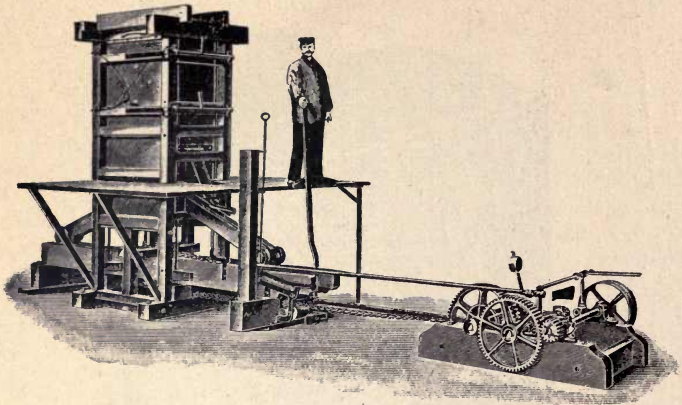


FIG. 225—Moss Litter Press for Motor-power.

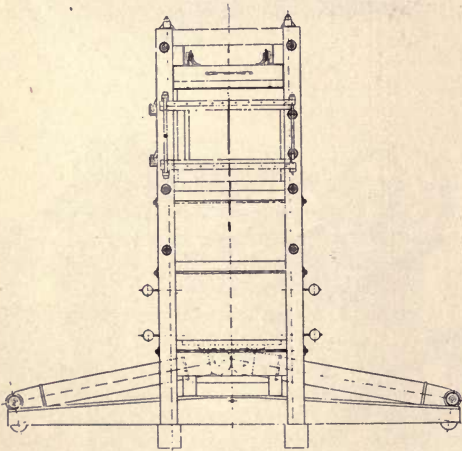


FIG. 226—Moss Litter Press for Motor-power.

The bog supplying the raw material to this plant is some 500 acres in extent, and contains little humified sphagnum peat with some smaller areas of more humified peat near the margin of the bog.

A ditch about 5 feet deep, with a width at the surface of 3.3 feet and at the bottom 1.6 feet, is dug around the bog in order to drain the working trenches and the surrounding surface area.

The working trenches are started 66 to 82 feet apart, and run parallel across the whole width of the bog. The work of digging the peat out of the



bog begins in the autumn, and continues until the required quantity is dug out, or until the frost sets in. The work is carried out as follows:—

In the lines staked out a 1.65 feet wide strip on each side of the line is dug out vertically. The peat is cut in brick-shaped pieces of the approximate dimensions 12 x 10 x 3 inches. The trench is four peat bricks in width and ten in depth. Seven peat bricks in depth are lifted up and placed in rows by the digger on the edge of the trench and from there they are laid out on the surface of the bog by another man by means of a fork, at such a distance from the trench that some 3.5 to 5 feet remain uncovered. The three lowest bricks, which are of a looser consistency, are cut out and laid out on this space, without any further handling. During the first year this work is paid for at the rate of 3.45 cents per cub. yard peat dug out. The second and following years the work is continued with a strip 1.65 feet in width on each side of the first trench, but on account of the setting of the bog (about 1 foot), on account of drainage, the bottom of the first trench is also deepened this distance. The work during the second and succeeding years is paid for at the rate of 3.2 cents per cub. yard.

The peat laid out is left during the winter, and until sufficiently dry to be handled in the spring, when the bricks are turned and raised with two bricks against each other. This work is paid for at the rate of 0.6 cents per cub. yard peat (measured in the trench). After being dried in this manner, the bricks are piled up in conical heaps, as shown in Figs. 8–9, and left until sufficiently dried, or with 20–30% moisture. The cost of this work is 0.8 cents per cub. yard, measured as before.

The dried peat is either stacked or stored in small sheds on the bog. The stacks or sheds are placed on every third working section, which is provided with permanent or portable tracks, for the transportation of the peat to the works. Light carriers, about 4 x 8 feet in dimensions, are used for carrying the peat to the stacks or sheds.

For stacking 2 cents is paid, and for storing in sheds 1.8 cents per cub. yard, measured in the stack or shed.

Occasionally the peat is loaded directly from the heaps into cars, and brought to the plant. In this case for loading and transportation 2.4 cents per cub. yard is paid. For loading and transportation from the stacks or sheds to the plant 1.6 cents per cub. yard is paid and for the moving of the portable tracks 0.3 cents per yard.

The moss litter plant is provided with 4 presses (see Fig. 227). All the necessary machinery is made by Abjörn Anderson's Mekaniska Verkstad Svedala, Sweden.

The peat cars brought from the bog, are, by means of hoists, brought up the elevated tracks (A), to the storehouse, where the peat is dumped. At the bottom of this room are two conveyors (B), which bring the peat to the tearing machines (C). The disintegrated material, by means of elevators (D), is conveyed to the rotating sieves (E),\* where the fibres are freed from

\*At this plant the sieves are covered with sheet iron, and the peat mull and moss litter are pressed together.

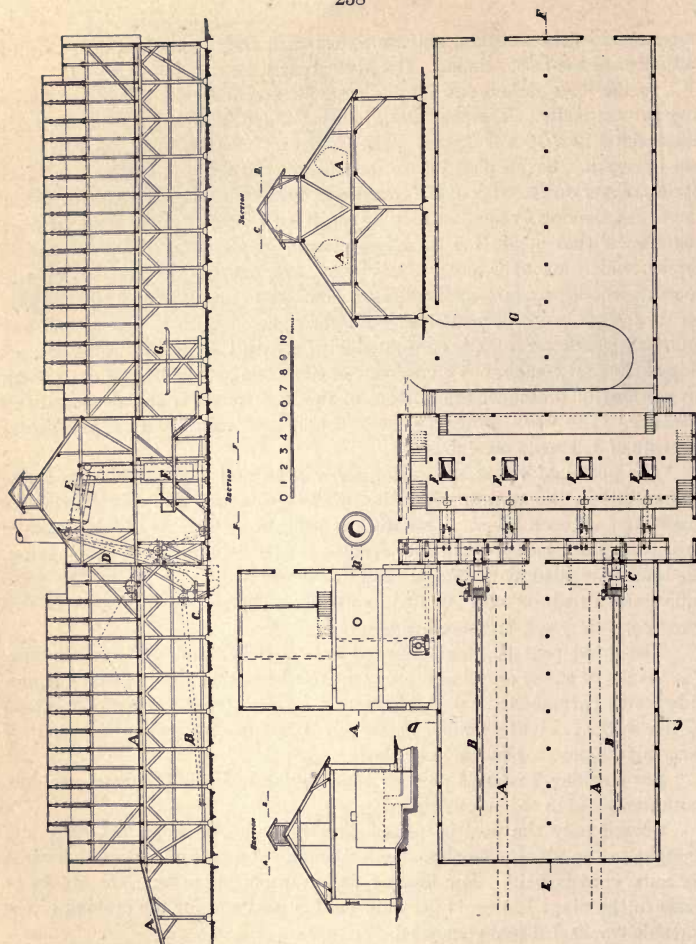


FIG. 227.—Moss Litter Plant with Four Presses.

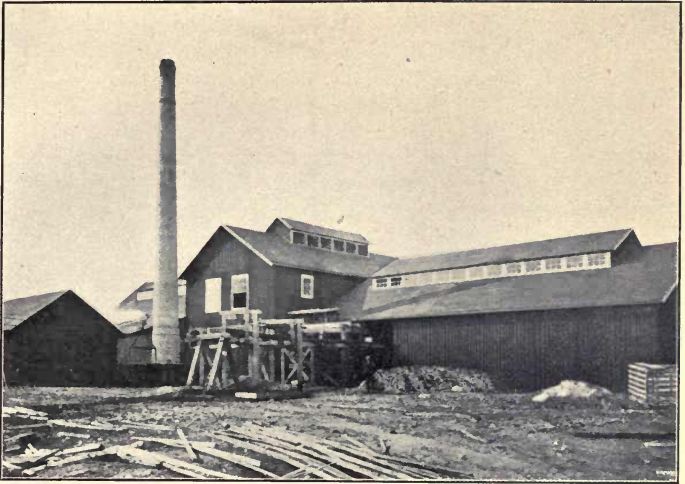
the mull, and from the sieves through shoots to the presses (F). Each press produces 175–225 bales per day of 10 hours. The dimensions of the bales are 40 x 28 x 20 inches, with an average weight of 150–165 lbs. per bale.

The pressing work is paid with 0.16 cents per bale.

The bales are brought to the railway station at Yxenhult by means of an aerial tramway (G), and loaded on cars.

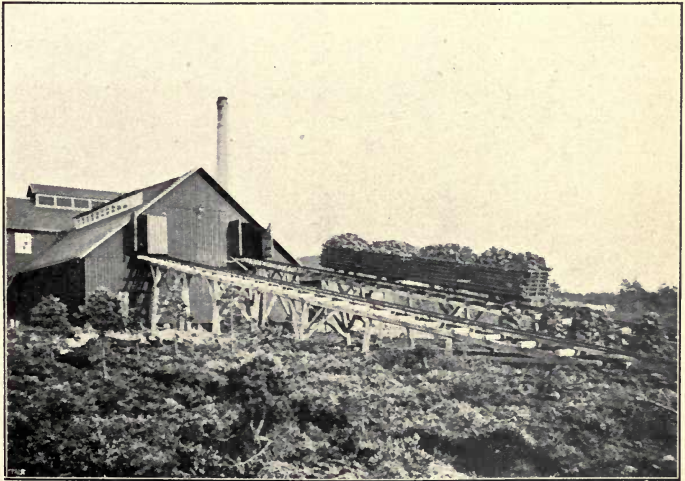
The power for the plant is supplied by a 50 h.p. steam engine, and the boilers are fired with peat refuse, sawdust, etc.

PLATE 33.



Moss Litter Plant with Four Presses, Hästveda, Sweden.

PLATE 34.



Moss Litter Plant with Four Presses, Hästveda, Sweden.



The cost of production at this plant, which has a yearly production of about 120,000 bales per year, is, including all expenditure, 20–21 cents per bale.

The moss litter is sold to members of the society which owns the plant, f.o.b. railway car, at Yxenhult, for 27 cents per bale.

The same society owns another plant of the same capacity (shown in Plates 33 and 34).

Fig. 228 shows a moss litter plant with two presses, but otherwise of the same construction in principle as the one with 4 presses shown in Fig. 227.

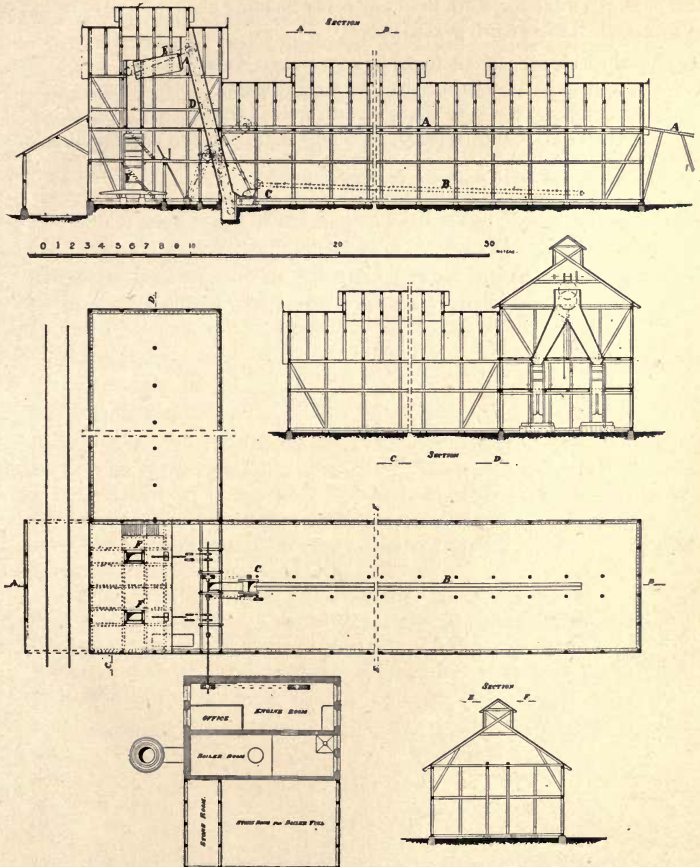


FIG. 228—Moss Litter Plant with Two Presses.

A very large number of moss litter plants has been erected in later years in Sweden, Norway, Germany and Holland, and this industry at present has a very promising outlook.

The selling price of the moss litter as well as of the peat mull naturally varies, but is, at present, on an average loaded on cars at the plant:—

In Sweden for moss litter. . . . .	20–25 cents per 100 lbs.
In Germany for moss litter. . . . .	15–22 “
In Germany for peat mull. . . . .	18–35 “

*Properties of Moss Litter.*—Well air-dried moss litter (about 20% moisture) absorbs more moisture than any other bedding material. According to tests made by the Swedish peat society:\*

Sawdust absorbs  $2\frac{4}{5}$ – $5\frac{1}{4}$  times its own weight water.

Straw absorbs  $3\frac{2}{3}$ – $4\frac{1}{2}$  times its own weight water.

Moss litter absorbs 8–16 times its own weight water.

Moss litter also absorbs gases, especially ammonia and carbon dioxide.

---

\*Svenska mosskulturföreningen, Jönköping, Sweden.

## CHAPTER IX.

## USES OF MOSS LITTER AND PEAT MULL AND OTHER PEAT PRODUCTS.

*Moss Litter for Bedding Purposes.*—Moss litter, on account of its great moisture absorbing property, makes the best bedding material, and its property to absorb foul-smelling gases makes it still more valuable. The air is therefore considerably sweeter in stables where moss litter is used instead of straw, and it is claimed that moss litter, on account of its disinfective property, has a very beneficial effect on the hoofs of the animals; and thrush, where moss litter is used, is very much reduced.

The Swedish peat society a few years ago made a test with different bedding material at their experimental plant at Flahult with the following results.

Each bedding material was used during a period of three weeks. A bed was first made, and on top of it enough of the same material to absorb all liquids. The manure was carefully collected, weighed and stored in a shed.

The analysis made showed that the following amounts of manure were obtained for each animal (young cattle) per day: with moss litter 41.14 lbs., with straw, 39.38 lbs., and with sawdust 45.98 lbs., which contained:—

Moss litter manure. . . . .	0.185 lbs. nitrogen.
Straw manure. . . . .	0.157 “
Sawdust manure. . . . .	0.138 “

Several other experiments made at different localities have also demonstrated that no other bedding material can absorb and retain the nitrogen to the same extent as moss litter. The manure, where moss litter is used, has therefore a considerably higher value as a fertilizer.

Moss litter can advantageously be used as bedding material for horses, cattle, pigs and hens, but not for sheep.

The moss litter should be well dried, and made of light coloured, little humified, sphagnum moss. A light litter is always better than a heavy one, and the lighter it is, the higher is its moisture absorbing property.

A litter, which with 20% moisture content can absorb 10 times its own weight moisture, absorbs with

30% moisture. . . . .	8½ times its own weight water.
40% “ . . . . .	7½ “ “ “
50% “ . . . . .	5⅔ “ “ “
60% “ . . . . .	4½ “ “ “
70% “ . . . . .	3 “ “ “

*Moss Litter for Insulation and Packing Purposes.*—Moss litter is a poor heat conductor, and is therefore used as coverings for steam pipes and boilers,

around water pipes to keep them from freezing and as a cover for garden plants during the winter. A layer of moss litter three feet thick is the best covering for ice heaps, and it is also used as filling material in buildings.

Moss litter is a light and elastic packing material, and is advantageously used for the packing of glass and such wares.

*Manufacture of Alcohol from Moss Litter.*—By converting the cellulose into sugar, alcohol can be made from peat. This has been known for quite a long time, and experiments have been made by several inventors and investigators.

The method used was as follows:—The peat was heated during a shorter or longer period under pressure with diluted sulphuric acid, in order to convert the cellulose into sugar. The acid juice was neutralized, filtered and the liquid fermented with yeast. When the fermentation was ready, the alcohol was obtained by distillation.

Experiments made by H. von Feilitzen in 1897 gave as an average 5.58% of the weight, of alcohol from water-free peat. The experiments also demonstrated that the alcohol obtained from more humified peat was less than that obtained from the undecomposed moss.

In 1905 a plant was in operation in Denmark, the method employed being invented by M. Reynaud who used a specially cultivated yeast for the fermentation.

The same method was introduced in Sweden, and some experiments superintended by a government officer were made with financial aid from the government.

The sphagnum moss used contained 62% moisture, or per 100 lbs., 38 lbs. dry peat substance.

The peat was heated in a large copper vessel with dilute sulphuric acid for 45 minutes, and under three atmospheres pressure. Each charge contained 495 lbs. moss litter, 99 gallon of water and 0.825 gallon sulphuric acid of ordinary strength (66° Bé).

The juice was neutralized with chalk, and after the sulphate of lime had settled, it was passed through a slime separator, and the liquid was fermented with the special yeast obtained from France. After 3–5 days, when the fermentation was ready, the alcohol was distilled.

The amount of alcohol obtained was 0.63–0.67 gallon per 100 lbs. dry peat substance, or on an average, 0.65 gallon.

The cost of manufacture is approximately estimated by H. von Feilitzen as follows:—

	Cents per litre alcohol.
Moss litter. ....	3.0
Sulphuric acid at 2.43c per litre. ....	1.7
Chalk at 0.4c per kilogram. ....	0.5
Labour, yeast, amortization of plant, etc., at least. ....	5.3
Total. ....	10.5 cents per litre

or about 47 cents per gallon.



*Peat Mull for Sanitary Purposes.*—Peat mull is a very efficient deodorizer, and to a certain extent is disinfective. It is therefore to a large extent used for closets, and in a large number of towns in Germany and other European countries, the use of peat mull for this purpose is made compulsory. The resulting “poudrette” has a high value as a fertilizer.

Peat mull for filtering sewage has also been experimented with.

By filtering the effluent water containing saline ammonia and other dissolved salts through peat mull, it is rendered pure and harmless. Sometimes peat coke is used for the same purpose.

*Peat Mull for Packing Purposes.*—For packing fruit and vegetables, peat mull has been found to give excellent results. Packed in boxes with peat mull, fruit keeps its freshness for months without decaying.

It is also advantageously used for packing and preserving meat, fish and eggs.

*Peat Molasses\*.*—Molasses has been used a long time in Germany for fattening cattle, but it has a purging effect, and in order to counteract this, peat mull very finely ground, was mixed with the molasses. The acid contained in the peat, especially the humic acid, neutralized the injurious potassium salts contained in the molasses, and rendered them harmless; the action of the mull counteracts the severe purging caused by the molasses alone.

The advantages claimed for peat-molasses are:—that it is 50% cheaper than the best fat-producing feed, and still equal in nourishment. It tends to keep the animal in health, help the digestion, sharpen the appetite, and is as good as bran. It increases and improves the milk from cows. It acts as a stimulant and increases the stamina of horses, and also prevents colic and other sicknesses.†

The usual manner of manufacturing peat molasses consists in heating it to 190° F. and mixing it with mull, while hot, in the proportion of 20 parts of mull to 80 parts of molasses.

*Manufacture of Peat Paper.*—Several processes have been invented for the manufacture of paper from peat (moss peat) or from a mixture of peat and wood pulp, but as far as known, none of these have proved economical. Paper can be made of fairly good quality, but so far, the cost of manufacture is as a rule too high.

The process invented by K. A. Zschörner, of Vienna, which was used at Frauenberg in Stiermark, Austria, is as follows:—

The peat is chemically treated in an apparatus containing five compartments.‡ “In the first the fibres are treated by a solution of alkali, not higher than 2° Beaumé, and gradually decreasing in strength by the addition of cold water. This is performed under a high pressure at a temperature of 4°–25° Cent. The second compartment, containing a solution of calcium or sodium hypo-chloride of a strength not exceeding 2° Beaumé, is employed

\*P. R. Björling & F. P. Gissing, Peat, its use and manufacture.

†A number of authorities disclaim that peat molasses has the properties claimed by the manufacturer of this article.

‡Björling and Gissing.

## GENERAL CONCLUSIONS.

*Air-dried Peat Fuel.*—The results obtained with the methods previously described clearly demonstrate that the manufacture of air-dried peat fuel, if properly conducted, is, in Europe, a sound business proposition. The conditions in Canada, at least in the southern parts of the interior provinces, are quite as favourable for the manufacture of peat fuel as those in Europe. In fact, the drying conditions are more favourable on account of the warmer and longer summer.

The methods and machinery to be employed for working the bogs must in each individual case, be determined by a thorough investigation, as to draining facilities, nature of the bog and local conditions. The neglect of these important factors in Canada is probably one of the reasons why the utilization of our bogs has so far mostly resulted in failures.

A method and machinery, which in a certain bog may work quite well, may, where conditions are different, prove entirely unsuitable.

Of the European methods described in this report, the digging of the peat by hand without any mechanical treatment (see pages 22-33) is not likely to prove acceptable in Canada except for a small production for domestic use, and for the manufacture of moss litter.

The method of adding water to the peat in the pulping and mixing machine (see pages 34-57) is a method to be recommended where suitable drying fields can be obtained, or where only a small production is required. The necessary machinery and other appliances are comparatively simple and cheap, and when the peat is well humified, a good fuel is obtained.

In the majority of cases, however, the employment of peat machines (see pages 57-129) is more suitable.

Where the bogs are comparatively free from roots, trunks and stumps of trees, the employment of mechanical excavators is a great advantage in such well drained bogs, the machinery and method invented and used by O. Strenge at Elisabethfehn, Oldenburg, Germany, is probably one of the best. (See pages 116-120).

Most bogs contain, however, a great number of roots and stumps, and in such cases the advantages of the mechanical excavators so far invented are doubtful. The most suitable machinery and methods for such bogs are those invented by A. Anrep. (See pages 77-82, 92-96).

*Peat and Lignite Briquettes.*—The manufacture of peat briquettes (see pages 130-148), which are preferable for domestic use on account of their higher fuel value and cleanliness, is, as far as can be judged, in Europe not a very lucrative undertaking. The increased fuel value does not cover the extra expense of artificial drying and briquetting.

The process invented by Dr. M. Ekenberg (the wet carbonizing process (see pages 160-170) where the peat is more or less fully carbonized and its fuel value thereby considerably increased, is, however, promising and is attracting much attention. The manufacture of lignite briquettes, on the other hand, has reached very large proportions, in Germany, and the machinery and methods there used are very satisfactory.

Part of the lignites in Manitoba and Saskatchewan would probably prove suitable for briquetting by these methods.

*Peat Powder.*—The process for the manufacture of peat powder lately invented by H. Ekelund (see pages 171-172) is claimed by experts to work satisfactory. The advantages of powdered fuels, especially in such industries as cement making, are evident, and for certain localities in Canada, of great importance.

*Peat Coke.*—The economical results obtained in this industry depend largely on the market and prices of the by-products obtained through the dry distillation of the peat. When these can be disposed of advantageously, the manufacture of peat coke is quite feasible. The best method invented for coking peat is the one invented by M. Ziegler (see pages 176-188).

*Uses of Peat for Heating and Steam Raising.*—Peat can be used advantageously instead of wood in any suitable apparatus. In fuel value one ton of ordinary coal is equal to 1.8 tons air-dried machine peat or 2.5 tons wood.

With peat firing on step grates, 1 lb. peat produces 4.03 lbs. steam.

With peat firing in half gas furnace, 1 lb. peat produces 3.76 lbs. steam.

With peat firing in gas producer, 1 lb. peat produces 4.70 lbs. steam.

*Peat Gas for Power Purposes.*—The most rational method of utilizing the peat bogs on a larger scale is undoubtedly through the erection of power plants at the bogs. (See pages 219-229). In this case the bulkiness of the peat fuel is of less consequence, and as the peat in the gas producers employed can be used with some 40-45% of moisture, the drying conditions are of less importance. Peat with 25-30% moisture is, however, desirable whenever possible to obtain.

*Moss Litter and Peat Mull.*—The manufacture of moss litter for bedding and packing purposes (see pages 230-242) is a rapidly growing industry in Europe, and on account of the large moisture absorbing property of moss litter, its use for these purposes is greatly to be recommended. Peat mull is also used with very satisfactory results as a packing material for fruit, eggs, etc. (see page 243), and for sanitary purposes.

*Other Uses of Peat.*—The manufacture of textile, paper, alcohol, etc., from peat (see pages 242-245), are, as far as at present can be judged, only in an experimental stage.





UNIVERSITY OF CALIFORNIA LIBRARY  
Los Angeles

This book is DUE on the last date stamped below.

DEC 9 1978  
6/6  
FEB 9 1978  
JAN 30 78

Form L9-100m-9,'52(A3105)444

THE LIBRARY  
UNIVERSITY OF CALIFORNIA  
LOS ANGELES

UCLA-Geology/Geophysics Library  
TP 340 C16p



L 006 557 720 7

UC SOUTHERN REGIONAL LIBRARY FACILITY



AA 001 210 350 3

