

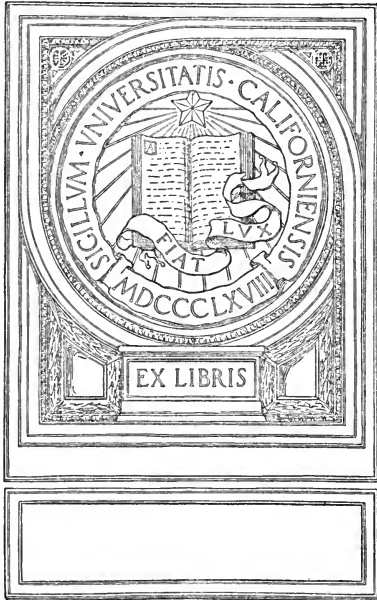

UNIVERSITY OF CALIFORNIA  
AT LOS ANGELES



The RALPH D. REED LIBRARY

DEPARTMENT OF GEOLOGY  
UNIVERSITY of CALIFORNIA  
LOS ANGELES, CALIF.

Gift of R.P. Mc Laughlin

---

---



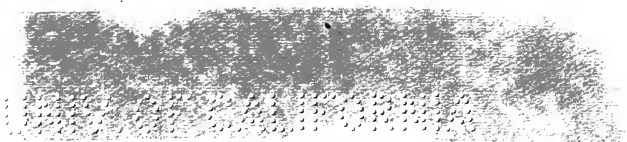

1944



AMBROLIAC TO VIRU  
ZINONA ZOLTA  
FRABLI

# PETROLEUM

# CHARLES GRIFFIN & CO., LTD.

PUBLISHERS OF

## STANDARD SCIENTIFIC AND TECHNOLOGICAL LITERATURE

"IN every department of Industrial Technology the student will find himself conning text-books bearing the imprint of Griffin."—*Textile Mercury*.

CHARLES GRIFFIN & CO. Ltd.'s Catalogue covers the following branches of Science and Technology:—

**ENGINEERING:** Structural, Docks, Harbours, etc., Hydraulic, Civil, Marine, Railway, Internal Combustion, Engineering Drawing and Design, Engineering Calculations, Professor Jamieson's Text-Books, Professor Rankine's Works, Aviation.

**ELECTRICAL PUBLICATIONS.**

**SHIPBUILDING.**

**NAUTICAL:** Griffin's Nautical Series, etc.

**MINING:** General, Coal Mining, Surveying, Treatment of Ores, Accounts, Valuation, Prospecting.

**GEOLOGY.**

**METALLURGY:** Griffin's Metallurgical Series, Assaying, Analysis, Smelting, etc., Foundry Practice.

**PETROLEUM:** Production and Use.

**LOCAL GOVERNMENT HANDBOOKS:** Water, Sewage, Drainage, Roadmaking.

**AGRICULTURE, DAIRY CHEMISTRY, etc.**

**CHEMISTRY and TECHNOLOGY:** General Reference, Foods, Fermentation Industries, Sanitation, Clay, Peat, Ceramics, Gas, Manufacture and Testing, Paper, Ink, Enamel, etc., Colour Industries, Textile Industries.

**GRIFFIN'S OPEN-AIR SERIES:** Botany, Ornithology, Geology.

**PHYSICS.**

**STATISTICS.**

**MEDICINE:** Medical Pocket- and Text-Books, "First-Aid."

**SCIENTIFIC ROMANCES.**

**EDUCATIONAL PUBLICATIONS.**

**RELIGIOUS WORKS.**

"IT is definiteness of purpose coupled with lucidity of treatment and aptness of illustration which has given the books of this firm their pre-eminence."—*Cassier's Engineering Monthly*.

"AS regards style of production it is only necessary to remind those interested that it emanates from the publishing house of Griffin."—*Shipping Record*, said in a recent review of a book issued by Charles Griffin & Co. Ltd.

WRITE for Charles Griffin & Co. Ltd.'s List, stating the subjects you are interested in, to

12 EXETER STREET, STRAND, W.C. 2



"PETROLEUM." BY SIR BOVERTON REDWOOD.

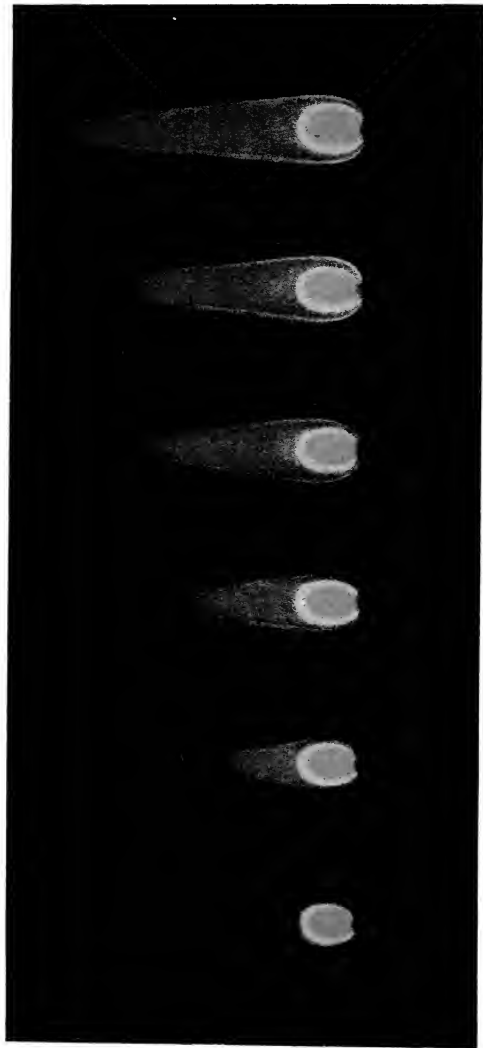

A B C D E F

PETROLEUM VAPOUR FLAME-CAPS OVER THE STANDARD HYDROGEN FLAME.

- A. Standard hydrogen flame in air free from vapour. | D. Flame-cap with 0.3% of pentane vapour.  
 B. Flame-cap with 0.05% of pentane vapour. | E. " " 0.6% " "  
 C. " " 0.1% " " | F. " " 0.8% " "

# PETROLEUM:

## A Treatise on

THE GEOGRAPHICAL DISTRIBUTION AND GEOLOGICAL OCCURRENCE OF PETROLEUM AND NATURAL GAS; THE PHYSICAL AND CHEMICAL PROPERTIES, PRODUCTION, AND REFINING OF PETROLEUM AND OZOKERITE; THE CHARACTERS AND USES, TESTING, TRANSPORT, AND STORAGE OF PETROLEUM PRODUCTS; AND THE LEGISLATIVE ENACTMENTS RELATING THERETO; TOGETHER WITH A DESCRIPTION OF THE SHALE-OIL AND ALLIED INDUSTRIES; AND A BIBLIOGRAPHY.

BY

SIR BOVERTON REDWOOD, BART.,

D.Sc., F.R.S.E., ASSOC. INST. C.E., F.I.C., ETC.

WITH A FOREWORD

BY

SIR FREDERICK W. BLACK, K.C.B.

FOURTH EDITION, RESET THROUGHOUT

Revised and largely Rewritten by the Author, in association with many Specialists.  
(See Preface.)

In Three Volumes, with Plates, Numerous Illustrations in the Text, and many New Maps specially prepared for this Edition.

VOL. III.



LONDON:

CHARLES GRIFFIN & COMPANY, LIMITED,

EXETER STREET, STRAND, W.C.2.

1922.

[All Rights Reserved.]

### WHAT THE JOURNALS HAVE SAID :

"It is indisputably the most comprehensive and complete treatise on Petroleum, and this statement is true, no matter on what branch of the industry a test of its merits is made. It is the only book in existence which gives the oilman a clear and reliable outline of the growth and present-day condition of the entire petroleum world."—*Petroleum World*.

"A veritable encyclopædia of the Oil Industry . . . even the comprehensive title fails to do full justice to the author."—*Times Engineering Supplement*.

"Will remain, as it has been in the past, the leading authority in the English language on the Petroleum Industry."—*Oil and Colour Trades Review*.

"A treatise which contains every conceivable item of information with regard to the subject . . . it should be of immense value to everyone to whom the Oil Industry is a matter of moment."—*Syren and Shipping*.

"An invaluable storehouse of information of every description relating to Petroleum."—*Bulletin of the Imperial Institute*.

"So perfect an example of what a book of reference should be."—*Nature*.

"The most important and complete single work on Oil ever published."—*Oil News*.



# A TREATISE ON PETROLEUM.

## SECTION IX.

### THE TESTING OF CRUDE PETROLEUM, PETROLEUM AND SHALE-OIL PRODUCTS, OZOKERITE AND ASPHALT.

A LARGE number of physical and chemical tests are applied to the raw materials and manufactured products to which this work relates. The industry is conducted upon a basis of recognised standards of quality, and testing is necessary on the one hand to satisfy the refiner that his processes are being properly conducted, and on the other to protect the buyer. Moreover, certain products are required to conform to statutory and municipal regulations, and prescribed tests have to be applied in connection with these restrictions.

**Crude Petroleum.**—The specific gravity of crude petroleum, and the amount of water and earthy matter in suspension, are usually ascertained. In many cases a test of fractional distillation is applied with a view of detecting any admixture of distilled products or residue. In Burma the flashing-point is frequently determined in connection with regulations relating to the transport. It may also be requisite, in the case of a crude oil from a new district, to take note of the colour and odour, to determine the flashing-point, the viscosity, whether separation of solid hydrocarbons takes place on cooling, and if so at what temperature, and whether sulphur is present, and if so in what proportion; also to ascertain experimentally what percentage of the usual commercial products, oil similar to the sample may be expected to yield on the manufacturing scale. In some instances it may be desirable to determine the elementary composition of an oil and its calorific value.

**Petroleum Spirit and Shale Spirit.**—In the case of petroleum spirit or naphtha, including benzine, gasoline, etc., the specific gravity and range of boiling-points are the most important characters, but the fractional distillation test is also sometimes applied. The percentages of distillate yielded by a sample at specified temperatures are frequently determined in order that it may be ascertained whether the volatility is in accord with specified requirements. Petroleum spirit should leave no unpleasant odour when it is evaporated on the hand. Shale spirit is similarly tested.

**Distillate (White Spirit).**—This product is now extensively used as a substitute for oil of turpentine in paints and varnishes, and, for such purposes, should contain no sulphur compounds. The range of distillation temperatures, specific gravity, flash-point, and colour are usually the most important physical characteristics of which data are required.

**Kerosene and Paraffin Oil.**—The colour, odour, flashing-point or fire-test, and specific gravity of kerosene and paraffin oil (from shale) are in most cases the only characters to be determined for contract purposes, and of these,

usually only the flashing-point or fire-test is taken cognisance of in legal enactments. The oil is, however, occasionally examined as to its "burning quality," its "capillary-power," its viscosity, its composition (as ascertained by fractional distillation), its acidity or alkalinity, its freedom from "soaps," its freedom from sulphur-compounds, and the amount of ash which it yields.

**Lighthouse Oil.**—The Trinity-House contract conditions for mineral oil intended for use in lighthouse lamps specify that—

1. The mineral oil required to be supplied under this contract is to be of the best possible quality, the greatest care is to be taken in its preparation, and it must be perfectly free from sulphuric acid.
2. In all cases, whether the oil be petroleum or paraffin, its flashing-point is to be determined by using the apparatus described in Schedule 1 of the Petroleum Act of 1879.
3. If the oil be petroleum, its flashing-point is to be not lower than 125° F. (close test), and it is to distil between 302° and 572° F., the temperature of the vapour, not that of the liquid, being taken.
4. If the oil be paraffin, its specific gravity is to be not less than 0.810, nor greater than 0.820, at 60° F.; its flashing-point is to be not lower than 140° F. (close test), and it is to distil between 302° and 572° F., the temperature of the vapour, not that of the liquid, being taken.
5. The illuminating power of the oil supplied, whether petroleum or paraffin, is to be equal to that of the best colza oil, when consumed in a Trinity-House Argand lamp.

For the distillation test, about 250 grams of the oil may be taken, the operation being conducted in an ordinary distillation flask, with the bulb of the thermometer midway between the shoulder of the flask and the lateral tube leading to the condenser. The upper part of the flask should be wrapped in asbestos cloth.

The United States Fuel Administration, in Bulletin No. 2, incorporates the following specification for lighthouse oil supplied to the Bureau of Lighthouses:—

1. The mineral oil must have a flash-point of not less than 140° F. and fire-point of not less than 160° F. (Tagliabue closed tester).
2. The mineral oil must contain no free acids or mineral salts. Litmus paper immersed in it for five hours must remain unchanged.
3. One hundred grams of mineral oil shaken with 40 grams of sulphuric acid (specific gravity 1.73) must show little or no coloration.
4. When distilled from a still, so jacketed as not to allow of local heating, at a rate of not over 10 per cent. in ten minutes, the mineral oil shall not distil below 350° F. and 98 per cent. shall distil under 515° F.—the temperature taken being that of the condensing vapour.
5. When burned for 120 hours in a lens lantern, supplied with a fifth order oil lamp, the mineral oil must burn steadily and clearly without smoking, with minimum incrustation of wick, slight discoloration of chimney and less than 10 per cent. loss of candle power.

**Mineral Colza (or Sperm) Oil.**—The colour, specific gravity, and flashing-point of this oil are commonly ascertained.

**Lubricating Oils.**—The principal characters to be determined in respect to lubricating oils are the viscosity, the flashing-point, the "cold-test," and the specific gravity. In some cases the loss by volatilisation on exposure to an elevated temperature is also ascertained. Lubricating oils should be free from acid and alkali. The viscosity of machinery-oils is usually determined in this country at the temperatures of 70° F. and 140° F., and of "cylinder" oils at

200° and 250° F. The extent of reduction in viscosity on an elevation of temperature is a point of practical importance; hence it is customary to make the test at two temperatures. The cold-test of "pale" machinery-oils is usually the point at which separation of solid hydrocarbons commences on a gradual reduction of temperature; and of "black" oils, the point at which the oil ceases to flow when slowly cooled. "Compound" oil, or mixtures of mineral oils with fixed oils, are largely employed for lubricating purposes, and it is frequently necessary to determine the proportions in which these oils are present. "Cylinder" oils—*i.e.* oils for the internal lubrication of steam-engine cylinders—should not contain fixed oils (or at any rate not more than a very small percentage), as the latter are decomposed by high-pressure steam, and soaps are formed by the action of the liberated fatty acids upon the metallic surfaces. Black oils should be free from solid matter in suspension. Occasionally the chemist is called upon to determine whether resin oil is present, or whether any agent has been added to impart artificial viscosity. In Italy there is a differential duty on mineral oils, and a fractional-distillation test is applied to lubricating oils to determine whether more than the maximum of 10 per cent. of distillate is obtained below 310° C. The operation is conducted with 20 grams of the oil in an ordinary distillation flask, with the bulb of the thermometer just below the vapour-tube.

**Paraffin.**—The testing of paraffin is usually confined to the determination of the "melting-point" (setting-point) and the percentage of oil, water, and dirt present.

**Vaseline.**—The tests which are occasionally applied to this product are chemical rather than physical.

**Petroleum Residuum.**—In testing petroleum residuum, it is usual to ascertain the specific gravity, the flashing-point, and the freedom from water and coke, or other solid matter.

**Fuel Oil.**—Oil for use as fuel should be free from solid matter in suspension, and is usually required to have a specified minimum flash-point, to retain its fluidity at a low temperature, and to contain not more than a specified percentage of water and of sulphur compounds. Suitable tests for ascertaining whether the oil conforms to contract requirements in these respects are accordingly applied.

**Gas Oil.**—Oil for gas-making is usually purchased on the basis of a specification which prescribes the method of testing.

**Crude Shale-Oil.**—In the testing of crude shale-oil, it is often sufficient to make a fractional distillation of a portion, and determine the specific gravity of each fraction of 5 per cent. and the setting-point of the less volatile.

**Ozokerite.**—The commercial analysis of crude ozokerite has for its object the determination of the percentage of refined ozokerite which the sample is capable of yielding.

**Asphalt.**—The examination of asphalt is usually confined to the determination of its physical characters at different temperatures, and its solubility in carbon bisulphide or other solvent.

The various tests to which reference has been made in these introductory remarks, and certain chemical tests, will be found fully described in the following pages.

At the Petroleum Conference held at Baku in 1886, the undermentioned classification of Russian petroleum products was adopted:—

1. Benzine—two sorts, *viz.* :—

(a) Light benzine—colourless; used for manufacturing indiarubber goods, and distilled at a temperature not below 130° C. or 266° F.

- (b) Heavy benzine—of a pale yellowish colour, yielding 10 per cent. refuse when distilled at a temperature as high as 150° C. or 302° F.
2. Kerosene—specific gravity 0.830; two sorts:—
    - (a) Safe—flashing-point not less than 25° C. or 77° F.
    - (b) Unsafe—flashing-point below 25° C. or 77° F.
  3. Astralin—specific gravity 0.850; of a pale yellowish colour; flashing-point not less than 50° C. or 122° F.
  4. Solar oil—specific gravity above 0.850, but not exceeding 0.880; flashing-point not below 80° C. or 176° F.; may be of very pale yellowish colour.
  5. Lubricating oils—specific gravity from 0.880 and upwards.
  6. Crude oil—specific gravity from 0.850 to 0.880; flashing-point below 70° C. or 158° F.
  7. Masut, or crude oil deprived of volatile light substances by exposure to air—specific gravity above 0.880; flashing-point above 70° C. or 158° F. and residue, locally called *ostatki*, flashing-point not below 140° C. or 284° F.
  8. The different petroleum products in a solid state—*asphalt*, *ozokerite*, etc.
  9. *Ceresine*, *paraffin*, *vaseline*.
  10. The different greases, varnishes, and mastics derived from petroleum.

### CRUDE PETROLEUM.

Ordinary crude petroleum is required, in the United States, to conform to the following rule of the New York Produce Exchange, except as regards specific gravity, the rule having been relaxed in that particular in consequence of much of the crude petroleum now obtained having a greater density than 43° B.:—

“Crude petroleum shall be understood to be pure natural oil, neither steamed nor treated, free from water, sediment, or any adulteration, of the gravity of 43° to 48° B.” (0.809 to 0.786 specific gravity).

In order to determine whether the petroleum is a “pure natural oil,” a sample is subjected to fractional distillation, each fraction being one-tenth of the crude oil by volume, and the densities of the several distillates are determined. The following results, obtained in the examination of two typical samples, indicate the form of the certificate handed to the buyer:—

Oil from Parker District.	Gravity 46° Baumé.	Oil from Bradford District.	Gravity 43° Baumé.
1st product, . . . . .	72° B.	1st product, . . . . .	71° B.
2nd “ . . . . .	62° B.	2nd “ . . . . .	60° B.
3rd “ . . . . .	57° B.	3rd “ . . . . .	54° B.
4th “ . . . . .	53° B.	4th “ . . . . .	49° B.
5th “ . . . . .	49° B.	5th “ . . . . .	45° B.
6th “ . . . . .	46° B.	6th “ . . . . .	41° B.
7th “ . . . . .	42° B.	7th “ . . . . .	40° B.
8th “ . . . . .	41° B.	8th “ . . . . .	41° B.
9th “ . . . . .	42° B.	9th “ . . . . .	42° B.

The regular gradation in the densities of the fractions exhibited in the foregoing certificates is regarded as a satisfactory indication that the oil is a natural product.

The natural lubricating oils (crude petroleum) of Pennsylvania, Ohio, West Virginia, and Kentucky have been classified by the West Virginia Transportation Company according to density, and subjected to the following test:—

“In receiving and making delivery of oils shipped by the company, the water and sediment contained therein shall be determined by mixing an

average sample with an equal quantity of benzine, and subjecting the mixture to 120° F. in a graduated glass vessel for not less than six hours, after which the mixture cools and settles not less than two hours for light grades, three hours for A grade, four hours for B grade, six hours for C grade, eight hours for D grade, and eighteen hours for heavier grades."

The author finds that in the case of the more viscous oils, a larger proportion of benzine, which should always be previously saturated with water, may be used with advantage.

The grades are as follows:—

- A. 37.1° Baumé (about 0.838 specific gravity) and lighter.
- B. 33° to 37° B. (0.859 to 0.838 specific gravity).
- C. 31.6° to 32.9° B. (0.867 to 0.859 specific gravity).
- D. 30.6° to 31.5° B. (0.872 to 0.867 specific gravity).
- E. 29.6° to 30.5° B. (0.877 to 0.872 specific gravity).
- F. 28.6° to 29.5° B. (0.883 to 0.877 specific gravity).
- G. 28.5° B. (0.883 specific gravity) and heavier.

**Determination of the Specific Gravity of Crude Petroleum and Petroleum Products.**—The specific gravity is usually determined in the trade by means of the *hydrometer*, but the use of a *specific-gravity bottle* is, in the opinion of the author, distinctly preferable. In the case of oils imported in bulk, where the weight delivered is calculated from the volume at the observed temperature, it is essential that the specific gravity should be accurately determined, and for this purpose the bottle should always be employed. The *Westphal* or *Sartorius balance* may sometimes be advantageously used instead of the hydrometer. In taking the specific gravities of viscous oils, the author has found that remarkably exact and trustworthy results may be obtained with the *Sprengel tube*. Allen<sup>1</sup> recommends the following method for the thicker and semi-solid oils. Fill a specific-gravity bottle to the brim with the warm oil, and when it has cooled to a temperature of 60° F., insert the stopper by working it to and fro until it is forced home, the excess of oil gradually escaping through the perforation in the stopper, then wipe the bottle, and weigh it.

It is frequently convenient to determine the specific gravity of viscous or semi-solid crude petroleum or lubricating oils at comparatively high temperatures, and to deduce the specific gravity at the standard temperatures from the result thus obtained, on the basis of the known coefficient of expansion of the particular class of oil under examination. Full particulars of the coefficients of expansion of various oils are given in the section relating to the physical and chemical properties of petroleum.

In calculating the total weight of oil delivered from the number of gallons transferred from a tank, it is customary in the United States to use a specific-gravity hydrometer with an open scale (0.800–0.805=1¼ in.), each division representing 0.0005. Tables have been prepared for the conversion of gauge into weight, based on the weight of an American gallon of distilled water at 60° F., which, in consultation with the author, was for this purpose taken as 8.331 lbs. avoirdupois.

In testing the quality of oils for commercial purposes, a hydrometer graduated in degrees Baumé is commonly employed in America.

The Director of the United States Government Department of Commerce and Labour, Bureau of Standards, has recently informed the author that the relation between specific gravity and degrees Baumé adopted by the Bureau

<sup>1</sup> *Commercial Organic Analysis*, 2nd ed., vol. ii.

of Standards, and in general use in the United States, for liquids lighter than water, is as follows:—

$$\text{Degrees Baumé} = \frac{140}{\text{Specific Gravity at } \frac{60^\circ}{60^\circ} \text{ F.}} - 130$$

or,

$$\text{Specific Gravity at } \frac{60^\circ}{60^\circ} \text{ F.} = \frac{140}{130 + \text{Degrees Baumé}}$$

This relation gives the equivalent values which will be found in Table CXXIX.

There is at present in use in the United States another Baumé scale for light liquids, based on the modulus 141.5, instead of 140, but it is believed that the one adopted by the Bureau of Standards will ultimately be universally employed.

TABLE CXXIX.—BAUMÉ AND SPECIFIC-GRAVITY EQUIVALENTS.

Baumé.	Sp. Gr.	Baumé.	Sp. Gr.	Baumé.	Sp. Gr.
10, . . . . .	1.0000	37, . . . . .	0.8383	64, . . . . .	0.7216
11, . . . . .	0.9929	38, . . . . .	0.8333	65, . . . . .	0.7179
12, . . . . .	0.9859	39, . . . . .	0.8284	66, . . . . .	0.7143
13, . . . . .	0.9790	40, . . . . .	0.8235	67, . . . . .	0.7106
14, . . . . .	0.9722	41, . . . . .	0.8187	68, . . . . .	0.7071
15, . . . . .	0.9655	42, . . . . .	0.8139	69, . . . . .	0.7035
16, . . . . .	0.9589	43, . . . . .	0.8092	70, . . . . .	0.7000
17, . . . . .	0.9524	44, . . . . .	0.8046	71, . . . . .	0.6965
18, . . . . .	0.9459	45, . . . . .	0.8000	72, . . . . .	0.6931
19, . . . . .	0.9396	46, . . . . .	0.7954	73, . . . . .	0.6896
20, . . . . .	0.9333	47, . . . . .	0.7910	74, . . . . .	0.6863
21, . . . . .	0.9271	48, . . . . .	0.7865	75, . . . . .	0.6829
22, . . . . .	0.9210	49, . . . . .	0.7821	76, . . . . .	0.6796
23, . . . . .	0.9150	50, . . . . .	0.7778	77, . . . . .	0.6763
24, . . . . .	0.9091	51, . . . . .	0.7735	78, . . . . .	0.6731
25, . . . . .	0.9032	52, . . . . .	0.7692	79, . . . . .	0.6698
26, . . . . .	0.8974	53, . . . . .	0.7650	80, . . . . .	0.6667
27, . . . . .	0.8917	54, . . . . .	0.7609	81, . . . . .	0.6635
28, . . . . .	0.8861	55, . . . . .	0.7567	82, . . . . .	0.6604
29, . . . . .	0.8805	56, . . . . .	0.7527	83, . . . . .	0.6573
30, . . . . .	0.8750	57, . . . . .	0.7487	84, . . . . .	0.6542
31, . . . . .	0.8696	58, . . . . .	0.7447	85, . . . . .	0.6512
32, . . . . .	0.8642	59, . . . . .	0.7407	86, . . . . .	0.6481
33, . . . . .	0.8589	60, . . . . .	0.7368	87, . . . . .	0.6452
34, . . . . .	0.8536	61, . . . . .	0.7330	88, . . . . .	0.6422
35, . . . . .	0.8485	62, . . . . .	0.7292	89, . . . . .	0.6393
36, . . . . .	0.8434	63, . . . . .	0.7254	90, . . . . .	0.6364

**The Fractional-Distillation Test for Crude Petroleum.**—The test prescribed by the New York Produce Exchange, to which reference has been made, may be readily carried out with a small still and condenser, or with any other simple form of distilling apparatus. On the other hand, the determination in the laboratory of the proportions of the various commercial products which a hitherto unknown description of crude petroleum may be expected to yield in practice is an operation not free from difficulty, and demanding some experience for its successful performance, especially if the quantity available for examination is small, as is often the case. The author is accustomed to conduct the process in a glass retort, or an ordinary distillation flask, embedded

in sand, heat being applied by means of Bunsen burners of various sizes, and the higher temperatures being taken with a nitrogen thermometer. The distillate is collected in fractions of one-tenth or less, the specific gravity of each fraction, and the behaviour of the less volatile of them on exposure to a low temperature, are noted, and these results, together with the temperatures within which the fractions distilled, are compared with data obtained, under identical conditions, with typical samples of crude petroleum of known commercial character. Some judgment is required in the interpretation of the results, because in practice, on the one hand, the process of "cracking," especially as conducted in the United States, results in the conversion into kerosene of much of the intermediate oil obtained in the ordinary laboratory process of distillation; and, on the other hand, owing to the use of superheated steam, there is far less dissociation in the distillation of the lubricating oil fractions. With a view of preventing this dissociation, the author has in some cases found it advantageous to effect the

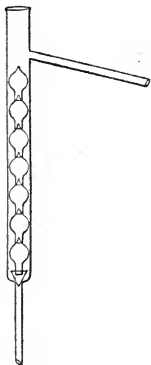

FIG. 211.

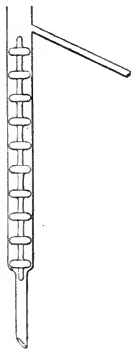

FIG. 212.

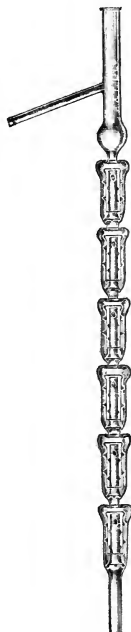

FIG. 213.



FIG. 214.

## DEPHLEGMATORS.

fractionation of the hydrocarbons of higher boiling-point under reduced pressure.

**The Dephlegmator.**—Except in the fractional distillation of the most volatile hydrocarbons, the author prefers to work without a dephlegmator. This appliance is, however, largely used. It is made in various forms, but the principle is substantially the same in all. It is well known that when a mixture of two liquids of different boiling-points is distilled, the distillate at any stage of the process will be found to contain both liquids, the more volatile predominating in the earlier, and the less volatile in the later stages, but complete separation not being thus effected. The function of the dephlegmator is partly that of a fractional condenser, and partly that of a "scrubber," the

less volatile liquid being condensed and returned to the distilling-vessel, and the apparatus being so constructed that the vapour is exposed to a portion of this condensed liquid, with the result that the more readily condensable constituents are washed out of it. In this way a better separation can be effected than is possible in the use of an ordinary distillation flask, but the employment of a dephlegmator in the fractionation of hydrocarbons of comparatively high boiling-point is attended with difficulty, and, according to the author's experience, appears often to interfere with the attainment of concordant results.

Modern forms of dephlegmators are those of Tervet and Sydney Young, indicated in figs. 211 and 212, and the Young "Evaporator" column shown in figs. 213 and 214. In the Tervet column the scrubbing effect is obtained by means of glass spheres inserted in an outer jacket, while in the Sydney Young a glass rod provided with discs performs a similar function. Either of these forms of dephlegmators is usually sufficient for ordinary purposes, but still more

vigorous fractionation is obtained by using a 3, 5, or 8 section "Evaporator" column.

It is claimed by some workers that the fractionating effect of a stillhead may be considerably enhanced by the use of a "lagging" material. For low and moderate temperatures an air space of annular shape, formed by surrounding the length of the column with glass tubing, has been shown to be very effective. For higher temperatures asbestos cloth wrapping has the same effect.

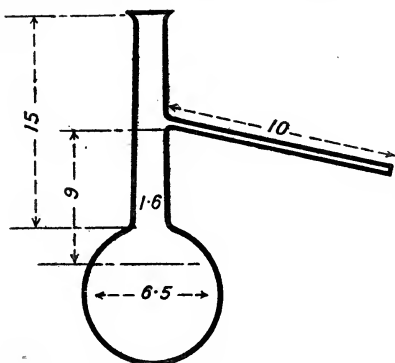

FIG. 215.—ENGLER FRACTIONATING FLASK.

#### Professor Engler's System of Distillation.—

For the fractional distillation of crude petroleum, Engler employs a globular flask (fig. 215)  $6\frac{1}{2}$  centimetres in diameter, with a cylindrical neck 1.6 centimetre in internal diameter and 15 centimetres in length, from the side of which a vapour-tube 10 centimetres in length extends at an angle of  $75^\circ$  downwards to the condenser. The junction of the vapour-tube with the neck of the flask should be 9 centimetres above the surface of the oil when the flask contains its charge of 100 c.c. of oil. The observance of the prescribed dimensions is considered essential to the attainment of uniformity of results. A thermometer is fixed in the cork inserted in the mouth of the flask so that the top of the bulb is on a level with the vapour-tube. 100 c.c. of the oil is introduced into the flask by the aid of a pipette, and heat is applied by means of a Bunsen burner. At first wire gauze is interposed between the burner and the flask, but afterwards the naked flame is employed, the heat being so regulated that from 2 to  $2\frac{1}{2}$  c.c. of distillate passes over per minute. In this way fractions differing from each other in boiling-point by  $50^\circ$ ,  $25^\circ$ , or  $20^\circ$  C. can be obtained. As soon as the requisite temperature ( $150^\circ$  C. for the first fraction) is attained, the lamp is withdrawn until the temperature has fallen at least  $20^\circ$ , when the oil is reheated to the boiling-point and again cooled, this process being repeated until



no more distillate is obtained. The oil is then heated up to the next boiling-point, and the cooling and reheating process repeated, and so on with the other fractions. These precautions must be observed in order to produce trustworthy results, which (it is claimed) can be obtained with not more than a variation of 1 per cent. by this method, even in the hands of different experimenters.

In a personal communication addressed to the author with reference to this process, Dr. Engler says:—

“ We estimate the proportion of burning oil from the amount of the fractions between 150° and 300° C. in the case of oils consisting of hydrocarbons of the methane series ( $C_nH_{2n+2}$ ), such as those from Pennsylvania, Galicia, Alsace, etc., or from the proportion of the fractions between 150° and 285° where the hydrocarbons belong to the naphthene series, as is the case with the Baku, Java, and (partially) the Burmese oils. As in practice some of the fractions below and exceeding the foregoing limits are included as burning oil, the proportion obtained on a manufacturing scale is greater than that yielded by a test-sample, but these limits give the nearest indication of the proportion of burning oil. A universal standard cannot, however, be established, because in some oils, and notably those from Baku, the fraction between 285° and 300° is so heavy as to prejudicially affect its capillary properties with regard to the lamp-wick. On the other hand, the same fraction in the American oils can be used for burning without seriously affecting the burning quality. We find inferior American oils contain as much as 15 per cent. by volume of fractions boiling below 150°, and 25 per cent. (volume) boiling over 300°, so these should be considered as the extreme limits.

“ If it is only a question of determining the amount of spirit, burning oil, etc., identical apparatus and method of working are, in my opinion, of greater importance than the complete separation of the single fractions. My apparatus, now very generally used in Germany, was designed with this object, and I discarded a dephlegmator as giving less regular results than a simple instrument, in the hands of different experimenters. By carefully following the directions, the margin of error is only about  $\frac{1}{4}$  to  $\frac{1}{2}$  per cent. At present we fractionate in stages of 25°; for instance, the benzine fraction boiling at, say, 86° would be included in the fraction boiling at 100°, and the subsequent fractions are taken at every 20° (100° to 125°, 125° to 150°, 150° to 175°, . . . 275° to 300°). By adding together the fractions up to 150°, the quantity of light spirit is ascertained; the burning oil comprising those between 150° and 300°, and so on. The former practice of taking fractions at every 20° is discontinued. However, in estimating the actual component parts of an oil, smaller fractions are necessary. In the burning oil, the greater the proportion of the first fraction above 150° the better, the converse being true in the case of the fraction above 250°.”

It should be noted that Dr. Engler's system of distillation was evidently designed for the examination of samples of crude petroleum, and for this purpose has been very frequently adopted in the exhaustive evaluation of hitherto unknown crude oils for the yield of commercial products. When samples of considerable quantity are available for examination, it has been found that a preliminary distillation test on the lines of the Engler test has been of considerable importance in determining the “cutting points” for the main distillation. In the author's opinion, however, the application of the Engler principle to the examination of petroleum products, and especially to those of contracted boiling-point range, is not justified by the results obtained by different operators, or even by the same operator, under slightly varying conditions.

**Regnault's Distilling Apparatus.**—In France the Regnault instrument is employed in fractional distillation. It consists of a copper retort, A (fig. 216), having a bent side tube, *b*, passing into a metallic condenser, B, which terminates, both above and below, in narrow tubes, *g* and *i*. The condenser is fitted into a cylinder, *f*, containing water, which is supplied through a pipe, *o*, *n*, and discharged at *p*. The whole is supported by a tripod, P, having a ledge, *h*, *l*, upon which is placed a box, V, containing graduated glasses for receiving the distillates, five in number, graduated in cubic centimetres. Each of the glasses, 1, 2, 3, 4, 5, can be brought under the outflow-tube, *i*, of the condenser. 100 cubic centimetres of the oil is introduced into the distilling vessel (which

should not be more than one-third full) through the neck, *a*. Through the cork closing the neck is passed a thermometer, T, the bulb of which should not dip into the liquid, but should be just below the tube leading to the condenser. Heat is applied by means of gas or a spirit-lamp, S. The oils contained in the crude petroleum may be fractionated into those—

Distilling below	150° C.
"	between 150° and 180° C.
"	" 180° and 210° C.
"	" 210° and 240° C.
"	" 240° and 270° C.

The receiving glass No. 1 is used to collect the first portion of distillate, No. 2 being substituted when the temperature rises above 150°, No. 3 when 180° is passed, and so on, No. 5 receiving the final fraction, obtained between 240° and 270° C. The volume of distillate in each glass is taken as representing the weight of the fraction in the original oil. This, though not exact, owing to the variation in the relation between specific gravity and volume in different fractions, is considered to be sufficiently correct for technical purposes.

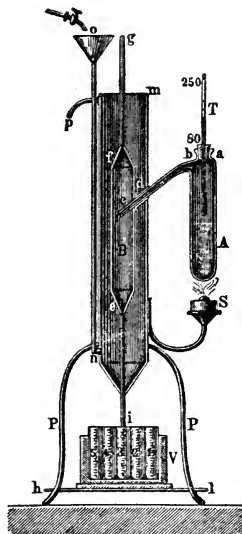

FIG. 216.—REGNAULT FRACTIONATING INSTRUMENT.

**Other Forms of Distilling Apparatus.**—Professor Peckham<sup>1</sup> recommends the use of an *alembic* in preference to a glass retort for the fractional distillation of crude petroleum in the laboratory, as the cracking of the oil is largely prevented. An apparatus devised for the purpose by Dr. Letheby is described in the *Journal of Gas Lighting*, xii, 653; another form, proposed by Dr. Attfield, in the *Pharmaceutical Journal*, 2, viii, 158; and a third, employed by Peckham, for the technical analysis of petroleum or solid bitumens by distillation, either with or without pressure, in the *American Journal of Science*, ser. 2, xlv, 230 (1867), and in the *Chemical News*, xvi, 199.

**Determination of the Calorific Value of Crude Petroleum, Petroleum-Residuum, and Fuel Oil.**—The elementary composition of crude petroleum (which is determined similarly to that of other organic bodies) does not necessarily indicate with precision the thermal efficiency of the oil, for the heat of combustion is dependent upon the state of combination of the elements in the sample,

<sup>1</sup> 10th U.S. Census Report on Petroleum, 1884, p. 53.

and this may vary without affecting the percentage-composition; in the case of crude petroleum or petroleum-residuum intended for use as liquid fuel, a direct calorimetric test is therefore desirable. The author finds that the instrument known as the *calorimetric bomb* is well suited for use in the determination of the thermal efficiency of petroleum, and he is accustomed to employ for the purpose a Mahler bomb lined with enamel. The process consists in burning the sample in a closed bomb in presence of excess of oxygen, the bomb being immersed in a calorimeter which is properly protected from loss or gain of heat by a suitable envelope. The water in the calorimeter is continually stirred during the progress of the experiment, and readings are taken with a cathetometer on delicate thermometers which indicate to  $\frac{1}{100}^{\circ}$  C. Of course the value in water of the whole system is accurately known, and as the products of combustion are retained in the bomb during the experiment, all the heat generated must be communicated to the water. Owing to the protection afforded to the calorimeter, and the means of reading, with precision, minute differences of temperature, extremely accurate and concordant measurements can be made. The necessary oxygen is introduced, under a pressure of about 25 atmospheres, into the bomb containing the oil, and the combustion started by means of a platinum wire heated to redness by electricity. Full directions for use are supplied with the instrument, and a translation of them will be found in *The Laboratory Book of Mineral Oil Testing*, by Jas. A. Hicks (Charles Griffin & Company, Ltd.).

There are modifications of the Mahler bomb calorimeter available, one of which is now being manufactured in this country, and this type has also given satisfaction in the determination of calorific value.

### PETROLEUM SPIRIT AND SHALE SPIRIT.

The rapid increase in the demand for petroleum and shale spirits which has occurred during the last few years has of necessity developed the actual and potential sources of supply, and, in addition, the range of boiling-points at one time considered to be the maximum permissible is now generally recognised to be quite inadequate, a higher final boiling-point being accepted as a necessary factor in the provision of ample supplies.

Fortunately, in consequence of a gradual, but well-marked growth in the efficiency of carburettors, this feature of the present-day spirits is not a serious drawback.

It is important that petroleum spirit or shale spirit intended for use in the carburetting of air or gas, or as a source of power in internal-combustion engines, should be fairly homogeneous in composition, and especially that it should not contain an undue proportion of hydrocarbons of comparatively high boiling-point. It is, therefore, frequently necessary to subject samples to the test of fractional distillation, and to determine the range of boiling-points, in addition to ascertaining the specific gravity of the spirit.

The examination is conducted in the author's laboratory in the following manner:—100 c.c. of the spirit is placed in a Wurtz flask supported on a sand-dish, and connected with a Liebig condenser. The bulb of the flask is  $2\frac{3}{4}$  inches in diameter, the neck  $\frac{3}{4}$  inch in diameter by  $5\frac{3}{4}$  inches in length, and the exit tube is  $2\frac{1}{2}$  inches above the shoulder. The tube of the Liebig condenser is 24 inches in length. The thermometer inserted through the cork in the tubulure is at first so adjusted that its bulb is just immersed in the spirit, and as soon as the ebullition becomes active it is gradually raised, so that the bulb is slightly below the rising level of the vapour (which can be seen

in a bright light). The temperature at which the first drop of distillate falls from the end of the exit tube of the flask into the condenser is noted as the initial boiling-point of the sample. Heating is controlled so that from 2 to 2½ c.c. of distillate per minute are collected. The percentages collected in a 100 c.c. measure-glass up to specified thermometer-readings are recorded, and the temperature at which the flask becomes dry is noted as the final boiling-point.

N. A. Anfilogoff has introduced<sup>1</sup> a modification of what is known as the Redwood test, the essential features of difference being the position of the thermometer bulb and the rate of distillation. Mr. Anfilogoff advocates that the top of the thermometer bulb should be placed half an inch below the exit tube of the flask at the commencement of the test, and the temperature at which the first drop falls from the thermometer back into the liquid due to condensation of vapour on the thermometer is noted as the initial boiling-point. Distillation then proceeds at the rate of two drops per second.

E. L. Lomax has published a description of a method which he has devised, and the following particulars relate to the apparatus used:—<sup>2</sup>

“The apparatus consists of a small round-bottom flask of 2½ inches diameter, the inside diameter of the neck being 1 inch, and its length from the shoulder 1½ inch. To this flask, by means of a sound, well-fitting cork, is attached a 4-pear Young dephlegmator column of total length 12¾ inches; length from bottom to side-arm, 10¾ inches, the beginning of the bottom pear being 3½ inches from the bottom of the column; and the total length of the 4 pears being 5¾ inches. The inside diameter of the tube from which the column is made is  $\frac{7}{16}$  inch, and the diameter of the pears is 1¼ inch. The side tube is bent at an angle of approximately 70°, and is 7¼ inches in length. The distillation apparatus is attached to an ordinary Liebig condenser, 22 inches long, fitted with an adapter, to lead the spirit into the 100 c.c. graduated reception-cylinder. An accurate thin-stem, small-bulb thermometer is fitted in the top of the column, the top of the bulb of the thermometer being level with bottom of the side-arm. The column is enclosed in a wide tube 8 inches long by 2 inches diameter, the bottom of which is fitted on to a cork, butting on to the cork connected to the flask, while the top of the tube is loosely packed with cotton wool. This wide tube serves to protect the column from draughts, and provides a very efficient air-lagging. It was suggested by a column designed for a different purpose by Mr. F. Esling, which was protected in a similar manner. In making the test, the column, with its protecting tube, is fitted to the flask, into which have been placed a few small pieces of boiling pot, and then 100 c.c. of the spirit to be tested is charged in by means of a pipette through the top of the column. The side tube is now connected to the condenser, and heating of the flask (which is protected by plain iron gauze) is commenced. A little practice soon enables one to estimate the size of flame necessary to bring the liquid to boiling-point at the desired rate.

“The initial boiling-point is taken as that at which the first drop falls from the side-arm. The distillation is continued at the rate of 2.5 c.c. per minute. This rate is conveniently timed by means of a metronome, previously so calibrated that, at the rate of one drop per beat, the distillation will be at the required rate.

“Readings of the distillates may be taken at any desired points, but for most practical purposes the amounts volatile below 100° C., 125°, and 150°, together with the total amount volatile, are all that are necessary. The final boiling-point is taken as that at which the flask becomes dry, which is usually

<sup>1</sup> *J.S.C.I.*, xxxvii, pp. 21–22 T.

<sup>2</sup> *Journ. Inst. Pet. Tech.*, iv (1917).

accentuated by the formation of a white cloud of vapour as a drop from the column falls on the hot bottom of the flask.”

It is suggested that the following average specifications represent suitable spirits in the three grades mentioned when these are tested according to his method :—

	No. 1 Quality.	No. 2 Quality.	Taxibus and heavy Motor Quality.
	Per cent.	Per cent.	Per cent.
Volatile below 100° C., . . =	25-30	15-25	10-15
"    "    125° C., . . =	60-65	50-60	45-50
"    "    150° C., . . =	85-90	70-80	60-70
Final boiling-point, . . =	170-180° C.	190-200° C.	200-210° C.

The United States Bureau of Mines<sup>1</sup> recommends for the distillation of motor gasoline the use of the Engler flask attached to a condenser consisting of a metal (brass or copper) tube  $\frac{1}{2}$  inch in diameter and 22 inches long, supported in a water trough 15 inches long and 6 inches deep. The gauze upon which the flask is supported has a circular opening in the centre  $1\frac{1}{2}$  inch in diameter, and the rate of distillation is between 4 and 5 c.c. per minute. No account is taken of the initial boiling-point, but readings of the thermometer are taken when each 10 per cent. has distilled over, and the temperature at which the flask becomes dry is also recorded.

The figures considered of chief importance are the temperatures at which 20 per cent., 50 per cent., and 90 per cent. distil, and the “dry point,” and, in order to prevent the inclusion of gasolines which have a serious evaporation loss, the minimum temperature at which 20 per cent. should distil is given as 70° C. The “dry point” should not exceed the temperature at which 90 per cent. distils by more than 55° C. Other than these two restrictions the range of boiling-points allowed must depend on the conditions under which the spirit is to be used.

In advising the railway companies on the construction of vessels suitable for the conveyance of petroleum spirit, Captain Thomson and the author found it necessary to devise a test by means of which the relative volatility of various products may be distinguished, from the point of view of the pressure which may be developed in a closed vessel on increase of temperature. The following is a description of the instrument which, after numerous experiments, was adopted for the purpose :—<sup>2</sup>

A thin glass tube, 6 inches long by 1 inch in diameter, is joined at its upper end to a short length of  $\frac{1}{4}$ -inch tubing, and at its lower end to a long capillary tube (1 mm. bore), which is bent up in the form of a U-tube and is graduated in inches.

The 1-inch tube is marked at a point near the bottom, and again near the top, these two marks being in such positions that the space between them is 90 per cent. of the total space above the lower mark.

The test is to be carried out as follows :—

Fit the short  $\frac{1}{4}$ -inch glass tube with a piece of stout rubber tubing, covering the whole of the glass tube, and projecting about  $\frac{3}{4}$  inch above. Wire this firmly on in two or three places. Fix the apparatus upright ; pour in mercury up to the lower mark on the bulb ; draw a little air through the mercury into

<sup>1</sup> *Technical Paper* 166.

<sup>2</sup> The makers of this instrument are Messrs. Müller & Co., 148 High Holborn, W.C.

the bulb to ensure that the mercury column in the capillary tube is unbroken. Pour in the spirit to be tested until it is well up to the upper line. Place the apparatus vertically in a vessel of water cooled down to 50° F. When the spirit has attained this temperature add a little spirit, if necessary, to bring the level up to the upper mark, then fit a strong screw pinch-cork on to the rubber tubing close above the glass tube, and screw up very firmly. Remove the apparatus from the cold water, and place it in a vessel of water heated to 100° F., taking care that the level of the water is well above the top of the rubber tubing, so that any leakage may be observed. Maintain the water at this temperature for half an hour, at the end of which time observe the height of the mercury column by the scale marked on the capillary tube. The height should not exceed 24 inches if the spirit is to be contained in the vessels recommended for the purpose.

The following method of fractionating petroleum spirit is adopted in the laboratory of Dr. Richard Kissling<sup>1</sup>:—A distilling-flask (the Engler flask already described) is charged with 100 c.c. of the benzine to be tested, and connected with a Liebig's condenser 60 cm. in length, which discharges into a measuring glass graduated to  $\frac{1}{2}$  c.c. The flask is supported by wire gauze such as is used in the filter-presses of sugar-refineries. At the beginning of the operation it is advisable to let the bent end of the adapter dip as far into the glass as possible, to minimise the evaporation of the lightest fractions. The rate of distillation recommended is 2 to 2½ c.c. per minute. At first the temperature usually rises rapidly, then more slowly, until it reaches a point where it remains practically stationary. This is the "lower boiling-limit" of the benzine under examination. At every rise of 10° from this point (beginning with the first even 10°) the volume of distillate is read off. Finally, when the bottom of the flask is free from liquid, a Bunsen flame is applied, and the temperature registered is considered as the "upper limit" of boiling. For this it is not necessary to drive off the last high-boiling portions (which at most amount to 0.1 to 0.2 per cent.). To ascertain their boiling-points, the thermometer must be lowered to the bottom of the neck of the flask. In the following table Kissling gives the results of distillations thus conducted:—

TABLE CXXX.—FRACTIONS OF BENZINE.

Benzine Tested.	Guaranteed boiling limits.	Distillate (in c.c.) up to											Lower boiling limit.	Higher boiling limit.	
		30° C.	40° C.	50° C.	60° C.	70° C.	80° C.	90° C.	100° C.	110° C.	120° C.	130° C.			
	° C.													° C.	° C.
1. Gasoline, (Petroleum ether)	30 to 100	0	37	66	81	95	97	97.5	98	...	...	...	31	121 (98%)	
2. Light Benzine,	60 to 100	...	...	...	0	53	89	96.5	97.5	98	98.5	...	62	123 (99%)	
3. Intermediate Benzine,	80 to 120	...	...	...	...	...	0	59	98	98.5	99	...	80	119 (99%)	
4. Heavy Benzine,	100 to 130	...	...	...	...	...	...	...	0	57	94	99	101	138 (99½%)	

<sup>1</sup> *Chemiker Zeitung*, xiv, 508 (1890).

**“WHITE SPIRIT” OR DISTILLATE.**

In addition to the determination of the flash-point (by the Abel apparatus) and specific gravity, distillation tests of this product are carried out in the author's laboratory in the apparatus described for the examination of petroleum spirit.

The initial and final boiling-points are determined and also the yields of distillate at intervals of 10° C. from the next even ten degrees after the initial boiling-point.

It is usually considered desirable that a sample should have a flash-point below 90° F., and that the final boiling-point should not greatly exceed 220° C. The sulphur content may be estimated by combustion in the calorimetric bomb, or by burning the product in a lamp and aspirating the products of combustion through an alkaline oxidising agent.

**KEROSENE AND PARAFFIN OIL.**

The following are the rules of the New York Produce Exchange relating to kerosene:—“Refined petroleum shall be standard white or better, with a burning test of 110° F. or upward, and of a specific gravity not below 44° B., United States Dispensatory Standard.

“The burning test of refined petroleum shall be determined by the use of the Saybolt Electric Instrument, and shall be operated in arriving at a result as follows:—In 110° and upwards, the flashing-points, after the first flash (which will generally occur between 90° and 95°), shall be taken at 95°, 100°, 104°, 108°, 110°, 112°, and 115°. In 120° and upwards, after first flash, at 100°, 105°, 110°, 115°, 118°, 120°, 122°, and 125°. In 130° and upwards, every five degrees until burning-point is reached.”

The following specifications for Water-White and Long-Time Burning Oils have been adopted by the United States Fuel Administration (Committee on Standardisation of Petroleum Specifications):—

**WATER-WHITE KEROSENE.**

*Appearance.*—Oil must be free from water, glue, and suspended matter.

*Flash.*—Not less than 115° F., Tagliabue closed cup, A.S.T.M. standard.

*Colour.*—To be 21 colour on Saybolt colorimeter or its equivalent on the Lovibond tintometer, these being equal to colour of a solution of potassium bichromate containing 0.0048 gram per litre.

*Sulphur.*—Not more than 0.06 per cent.

*Floc.*—Oil to be free from “floc.”

*Distillation.*—Oil to distil below temperature of 600° F.

*Cloud Test.*—Oil should not show cloud at 0° F.

*Reaction.*—Must be neither acid nor alkaline.

*Burning Test.*—The oil must burn freely and steadily in a lamp fitted with a No. 1 sun-hinge burner. It must give a good flame for a period of 18 hours without smoking or forming “ears” or “toadstools” on the wick. The chimney must be only slightly clouded or stained at the end of the test.

Water-white kerosene for use as fuel by United States Navy should have a heating value of at least 20,000 B.T.U. per pound.

It may also have to be tested photometrically in a lamp fitted with a No. 1 sun-hinge burner. The candle-power should be at least equal to 6 candles, and the diminution between two tests, the first made one hour after the lamp is started and the second after five more hours burning, should not exceed 5 per cent.

**LONG-TIME BURNING OIL.**

*Appearance.*—Oil must be free from water, glue, and suspended matter.

*Flash.*—Not less than 115° F., Tagliabue closed cup, A.S.T.M. standard.

*Colour.*—Twenty-one colour on Saybolt colorimeter or its equivalent on a Lovibond tintometer, these being equal to colour of a solution of potassium bichromate containing 0.0048 gram per litre.

*Floc.*—Oil to be free from “floc.”

*Cloud Test.*—Oil should not show cloud at 0° F.

(*Note.*—Temperature of 0° F. can be varied either up or down to suit the climatic conditions in the territory in which the oil is to be used.)

*Reaction.*—Must be neither acid nor alkaline.

*Burning Test.*—Made by introducing 25 fluid ounces of oil into the pot of a standard Railway Signal Association semaphore lamp, fitted with the purchaser's standard burner, chimney, and wick. The wick shall be new and previously washed with redistilled ether and dried at room temperature; the lamp to be protected from the direct rays of the sun, but may be burned either outdoors or in a well-ventilated room. During the first hour of the test the wick will be adjusted so as to produce a flame  $\frac{3}{4}$  inch high, measured from the top of the wick. The lamp shall burn continuously without readjusting the wick for 120 hours, or until all of the oil is consumed.

The flame shall remain symmetrical and free from smoke throughout the test period.

The height of the flame at any time during the test shall be not less than  $\frac{3}{4}$  of an inch. The oil shall not produce any appreciable hard incrustation on the wick.

The rules of the Petrolea (Canada) Oil Exchange provided that refined kerosene should be of the odour “locally known as inoffensive,” and should “absolutely stand the test of oxide of lead in a strong solution of caustic soda without change of colour.” The “burning percentage” in the case of “extra refined oil,” “water white” in colour, and of specific gravity not exceeding 0.800, was required to be not less than 70; in the case of “No. 1 refined oil,” “prime white” in colour, not less than 60; and in the case of “No. 2 refined oil,” “standard white” in colour, to be not less than 55. The “burning percentage” was ascertained in the manner described on p. 759.

The following are the recognised tests applied to Russian kerosene in the principal refineries in Baku:—1. The oil must be clear and bright, and in case it has become opalescent through contact with water, it must, when poured into an open glass, become bright at a moderate temperature (15° C.). 2. The odour must be “pure.” 3. The colour should not be darker than 2½ (midway between “superfine white” and “prime white”). 4. The flashing-point, Abel-Pensky test, must not be lower than 28° C. 5. The distillation test is made in a flask of 500 c.c. capacity, which is wrapped round six or eight times with fine wire gauze, over a naked gas or spirit flame. The distillation is conducted at such a rate that about 2 grams is distilled per minute. As soon as the limit of the spirit is reached (150° C.) the rate of distillation is reduced, so that only one-half of a gram comes over per minute, and the temperature is then gradually increased so that 2 grams per minute is distilled. The charge placed in the flask is 250 grams. All products distilling below 150° C. should be considered spirit; from 150° to 270°, normal kerosene (some adopt 275° or 280° as the limit); and above 270°, heavy oils. A good kerosene may contain, according to the season of the year, from 9 to 14 per cent. of spirit, of specific gravity about 0.771 to 0.774 at 17½° C.; from 67 to 88 per cent. of normal kerosene, of specific gravity about 0.824 to 0.827; and from 9 to 13 per cent. of heavy oils, of specific gravity about 0.863 to 0.865. 6. Ash test: 1000 grams is distilled down in a retort (wrapped round with wire gauze) to about 40 grams. The remainder is then boiled down in a platinum capsule, and the residue strongly heated until all the carbon is burnt. There should not be more than 10 milligrams of ash. 7. Soda test, for “soaps”: 500 c.c. of the oil is heated in a flask with 10 c.c. of caustic-soda solution (1.014 specific gravity) to 70° C., the two liquids thoroughly shaken together for three minutes, allowed to stand for some time, and the oil decanted off. The soda solution is filtered, and distinctly acidulated with hydrochloric acid. The solution thus obtained should be only slightly opalescent, so that through a column half an inch in length the finest writing can be distinctly read. The



following is a scale adopted in some cases:—No. 0, quite bright; No. 1, slightly opalescent; No. 2, opalescent, so that handwriting can be read; No. 3, opalescent, so that only large characters are readable; No. 4, opalescent, so that large characters are only visible; No. 5, milky. Further information relative to this test will be found in the latter part of this section. 8. Photometric test: 375 grams of the oil is burnt, during nine hours, in a Kumberg lamp with a ten-line flat burner. The illuminating power is taken at the expiration of the first quarter of an hour (when it is usually from 10 to 11 candles), and again as soon as 80 millimetres in depth of the oil in the lamp-reservoir has been burnt. Good oil should not lose more than 20 per cent. of its illuminating power, the diminution with the best oil being from 3 to 9 per cent. 9. The oil should be absolutely neutral. The test should be made with a pale but very sensitive solution of litmus in 60 per cent. spirit. 200 c.c. of the oil should be shaken with 10 c.c. of the litmus solution. 10. Sulphuric acid test (usually omitted): 4 c.c. of the oil is shaken for two minutes thoroughly with 2 c.c. of sulphuric acid of 1.835 specific gravity. The kerosene should not turn red-brown.

**The Distillation-Test for Burning Oil.**—Dr. Engler<sup>1</sup> strongly recommends fractional distillation as a test for burning oil, in conjunction with the determination of the flashing-point and viscosity, it being important, in his opinion, to know not only the proportion boiling between 150° and 300° C. (or other maximum limit fixed with due regard to the character of the oil), but in addition the amounts of the intermediate fractions, as also affecting the burning quality of an oil. The precise manner in which Engler applies the test has already been described in connection with the examination of crude petroleum. With reference to the 150° to 300° limits, Beilstein<sup>2</sup> considers that a good oil should contain not more than 5 per cent. of hydrocarbons having boiling-points below these limits, nor more than 15 per cent. having boiling-points above, but it is evident that this rule does not admit of universal application. J. Biel<sup>3</sup> distils 250 grams of the sample in a 500-c.c. flask, wrapped tightly with brass gauze or glass wool to protect it from too rapid changes of temperature. The flask is fitted with a Glynsky's dephlegmator, in which a thermometer is inserted so that the bulb is on the level with the exit-tube. At first a small flame is applied to drive off the lighter products, and this gentle heat is maintained as long as any notable quantity (more than 10 drops per minute) distils at 150° C. The flame is then enlarged, and a product obtained distilling between 150° and 270°, this being the "normal" kerosene. In this manner the following results were obtained with typical samples of Russian kerosene and solar oil or pyronaphtha:—

TABLE CXXXI.—FRACTIONS OF KEROSENE AND SOLAR OIL (BIEL).

	Kerosene.			Pyronaphtha.	
	A.	B.	C.	D.	E.
Specific gravity, . . .	0.820	0.820	0.835	0.857	0.867
Flashing-point, . . .	52.5° C.	35.0° C.	44.5° C.	75.0° C.	94.0° C.
	Per cent.	Per cent.	Per cent.	Per cent.	Per cent.
Below 150° C., . . .	0.8	10.0	6.0	0.0	0.0
150° to 270° C., . . .	92.0	76.5	63.5	44.5	30.5
Residue, . . . . .	7.2	13.5	30.5	55.5	69.5

<sup>1</sup> Post's *Chemisch-technische Analyse*, 2nd ed., i, 276-278.<sup>2</sup> *Zeitschrift f. anal. Chemie*, xxii, 313 (1883).<sup>3</sup> *Dingler's polytech. Journ.*, cclii, 119 (1884).

Working with a glass retort, with the bulb of the thermometer immersed in the oil, Biel obtained the following results:—

TABLE CXXXII.—FRACTIONS OF AMERICAN AND RUSSIAN OILS (BIEL).

	American		Russian.	
	No. 1.	No. 2.	No. 1.	No. 2.
Specific gravity, . . . . .	0·795	0·783	0·803	0·822
Flashing-point, . . . . .	26° C.	48° C.	26° C.	30° C.
	Per cent.	Per cent.	Per cent.	Per cent.
Below 150° C., . . . . .	14·4	2·2	33·5	12·8
150° to 270° C., . . . . .	45·9	87·8	66·5	78·3
Residue, . . . . .	39·7	10·0	...	8·9

The following results were obtained by the author in the fractional distillation of typical samples of American and Russian kerosene. A measured quantity was distilled, and the density of each fraction of 10 per cent. by volume was determined:—

TABLE CXXXIII.—FRACTIONS OF AMERICAN AND RUSSIAN KEROSENE (REDWOOD).

Number of Fraction.	American. Sp. Gr. 0·803.	Russian. Sp. Gr. 0·822.
1	0·748	0·783
2	0·759	0·796
3	0·778	0·803
4	0·792	0·814
5	0·802	0·827
6	0·812	0·831
7	0·822	0·837
8	0·831	0·838
9	0·838	0·846
Residue	0·849	0·864

Dr. Thörner<sup>1</sup> employs a distillation flask made of copper. The flask is about 200 c.c. capacity, has a neck 12 centimetres long and 1·8 centimetre wide, and an exit-tube, serving as a condenser, 45 centimetres long and 0·7 centimetre wide. This tube is bent downwards at the end, and introduced into the measuring cylinder, which holds 100 c.c. up to two-thirds of its height, and is divided into 0·5 c.c. The cylinder is placed in a cooling-vessel. The flask is charged with 100 c.c. of the oil, and the distillation occupies from twenty-five to thirty minutes. The bulb of the thermometer is apparently placed half-way between the exit-tube and the bottom of the neck of the flask.

Dr. Engler<sup>2</sup> gives the following tests as being applied in Russian refineries to refined kerosene:—

1. *For Organic Acids.*—Agitation with 2 per cent. of soda solution, 1·2 specific gravity, and acidifying the alkaline fluid after allowing it to settle. The intensity of milky turbidity is a measure of the amount of acids.

<sup>1</sup> *Chem. Zeit.*, x, 528–530, 553, 554, 573, 574, 582, 583, 601–603; *Journ. Soc. Chem. Ind.*, v, 371 (1886).

<sup>2</sup> *Dingler's polytech. Journ.*, cclx, 436 (1886).

2. *For Sufficient Acid Treatment.*—A sample is taken up with a few drops of soda solution into an emulsion, which should be perfectly white by reflected light without a trace of yellow.

3. *Colorimetric Examination.*—By Stammer's instrument.

4. *Photometric Test.*—By Bunsen's apparatus with standard candle.

5. *Distillation Test.*—250 grams of the oil is distilled in a flask fitted with Glynsky's dephlegmator.

6. *Flashing-Point.*—Determined by the Abel test.

**Burning Quality Test.**—Although the distillation test affords an indication of the value of an oil for illuminating purposes,<sup>1</sup> more practical results are obtained by burning the oil in lamps under conditions as close as possible to those existing in ordinary use.

In most of the United States refineries the oil is tested by burning it in lamps of ordinary construction, and noting the diminution in the size of the flame after a certain time. The results thus obtained depend upon many variable conditions, and attempts have been made to eliminate some of the sources of variation.

**Saybolt's Apparatus.**—The Saybolt testing-lamp (fig. 217) consists of a tall graduated glass vessel with a burner which gives a flame of considerable height in comparison with its width. The chimney is also graduated so that the height of the flame may be measured. A carefully selected wick is used, and the lamp is burned with the reservoir in a vessel of water at 60° F. The depression of the oil-level and the diminution in the height of the flame at the expiration of a given time are noted, and the "burning quality" of the oil is judged therefrom.

**Canadian Method.**—In Canada the "burning percentage" was formerly determined by the use of a lamp thus described: "The bowl of the lamp is cylindrical, 4 inches in diameter and 2 $\frac{3}{4}$  inches deep, with a neck placed thereon of such a height that the top of the wick tube is 3 inches above the bowl. A 'sun-hinge' burner is used, taking a wick  $\frac{7}{8}$  inch wide and  $\frac{1}{8}$  inch thick, and a chimney about 8 inches long." The test is conducted as follows:—"The lamp-bowl is filled with the oil, and weighed, then lighted and turned up full flame, just below the smoking-point, and burned without interference till 12 ounces of the oil is consumed. The quantity consumed during the first hour and the last hour is noted." The ratio of the two quantities is the measure of the burning quality, and the percentage that the latter quantity is of the former is the "burning percentage" referred to.

**Redwood's Apparatus.**—In the laboratory of the author, the wicks employed in ascertaining the burning quality of oils are examined by means of the apparatus shown in fig. 218, and any defective portion is rejected. The test consists in arranging a given length of the wick so as to draw, by capillarity, a mineral oil of known quality from a vessel, at a fixed temperature, the value of the wick being gauged by the amount of oil drawn out in a certain time. The wick is dried immediately before use, and immersed in the oil while still warm. The oil-chambers of the lamps in which the tested wicks are subsequently used are of uniform dimensions, and the burners are first tested to ascertain



FIG. 217.—SAYBOLT TESTING LAMP.

<sup>1</sup> The viscosity of the oil affords, in some cases, a useful indication of the burning quality.

that they give similar flames with the same oil. The wick should be very carefully trimmed, and the oil in the lamp should be kept at a constant temperature, preferably at 60° F. The wick should be raised to yield the largest flame obtainable without smoke. For registering variations in the size and shape of the flame during the test, a camera is employed by the author, by means of which the outline of the flame may be traced at intervals on thin paper, as shown in fig. 219. No general agreement has, however, been arrived at as to the extent of diminution allowable in the flame from an oil classed as of satisfactory burning quality. The

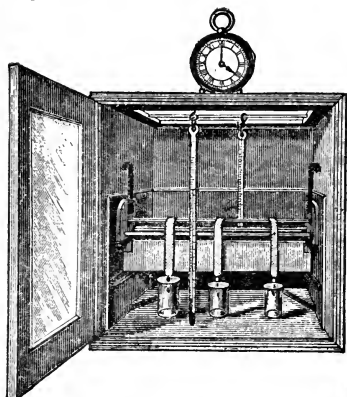

FIG. 218.—REDWOOD WICK-TESTER.

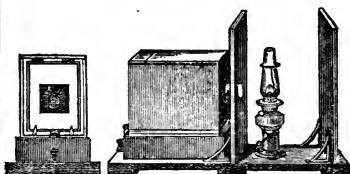

FIG. 219.—CAMERA FOR VARIATION OF FLAME.

apparatus already described (fig. 218) is also employed by the author in determining the relative capillary values of various oils.

**Illuminating Power.**—The following table gives the results of comparative photometric tests made by the author with American kerosene and Russian kerosene (Nobel's make), in ordinary lamps with Hink's duplex burner<sup>1</sup> and with two kinds of wick, one loosely woven, and the other somewhat more tightly woven:—

TABLE CXXXIV.—PHOTOMETRIC COMPARISON OF KEROSENES.

	American Kerosene.		Russian Kerosene.	
	Loosely-woven Wick.	Tightly-woven Wick.	Loosely-woven Wick.	Tightly-woven Wick.
	Standard Candles.	Standard Candles.	Standard Candles.	Standard Candles.
Maximum illuminating power, . . .	25·59	24·25	22·1	19·14
Minimum illuminating power, after six hours, . . .	22·24	19·16	20·5	17·4
Average illuminating power, during six hours, . . .	23·96	22·14	21·2	18·04
Diminution in illuminating power, in six hours, . . .	Per cent. 13·0	Per cent. 20·9	Per cent. 7·2	Per cent. 9·0
	Grains. 1238	Grains. 1213	Grains. 1137	Grains. 981·6
Oil consumed per hour, . . .	1238	1213	1137	981·6
Oil consumed per candle-light per hour, . . .	51·6	54·7	53·6	54·4

<sup>1</sup> These tests were not made with the present form of this burner, which has a higher illuminating power for a given consumption of oil.

The Russian oil did not give as much light as the American, but there was considerably less diminution in the illuminating power as the level of the oil in the reservoir became depressed.

In determining the illuminating power of oils, the author is accustomed to employ a Bunsen's photometer, but the sight-box should be adjustable so as to admit of the measurement of the light-giving power, not only of the rays proceeding horizontally from the lamp, but of those projected at various angles.

**Determination of Colour.**—For determining the *colour* of petroleum, an operation which is particularly necessary in the case of *kerosene*, it was formerly the practice to compare the sample with a standard oil placed beside it in a bottle of similar size. This method being unsatisfactory, the author adopted the plan of placing the samples in long glass cylinders held in a frame in such a manner that the images of the glass bottoms of the cylinders could be seen side by side in a mirror. This arrangement was found more satisfactory in the case of a fluorescent liquid like petroleum, than looking down on the oils while the cylinders are placed on a white surface, but, as in the previous one, the test was vitiated by the liability of the standard samples to change colour.

The adoption by the trade of precise conditions of contract necessitated the provision of a more exact method of testing, and more than twenty-five years ago the Petroleum Association decided, under the advice of the author, to employ the Wilson chromometer, in which the colour is compared with a series of glass standards.

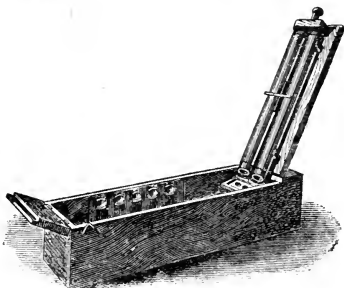

FIG. 220.—WILSON CHROMOMETER.

**Wilson's Chromometer.**—This instrument (fig. 220) consists of two similar tubes, 16 inches in length, closed at each end by a screw-cap carrying a stout glass disc. Light is reflected upwards through the tubes by a mirror, and is then, by two pairs of prisms, twice reflected, and thus brought into an eye-piece. One of the tubes is *filled* with the oil to be tested, and beneath the other, which is empty, a disc of stained glass is placed. On looking through the eyepiece, the field is seen to be divided by a sharp line formed at the juncture of the two pairs of prisms, the two halves of the field being tinted respectively with the colour of the oil and that of the standard. An accurate comparison can thus be made. The four glass standards representing the various grades of colour now recognised commercially are known as—

- |                       |                    |
|-----------------------|--------------------|
| 1. Water white.       | 3. Prime white.    |
| 2. Superfine white.   | 4. Standard white. |
| 5. Good merchantable. |                    |

(Oils darker in colour than "good merchantable" are classed as "not good merchantable.")

Although this apparatus answers well for ordinary work, it does not serve to absolutely define the shade of colour of a sample, or to indicate the extent to which it differs from the standard.

**Stammer's Chromometer.**—To meet this want, the Stammer chromometer was introduced, in which the length of the oil-column can be varied, so that,

by starting with a standard of paler tint than that of the sample, the column of oil may be shortened until the two match, and the colour of the oil may thus be found in terms of the standard, 40 on the scale of Stammer's chromometer being equal to standard white, 50 to prime white, and 190 to superfine white.

Fig. 221 shows the apparatus, as made by Messrs. Schmidt & Haensch of Berlin, the parts being lettered as follows:—

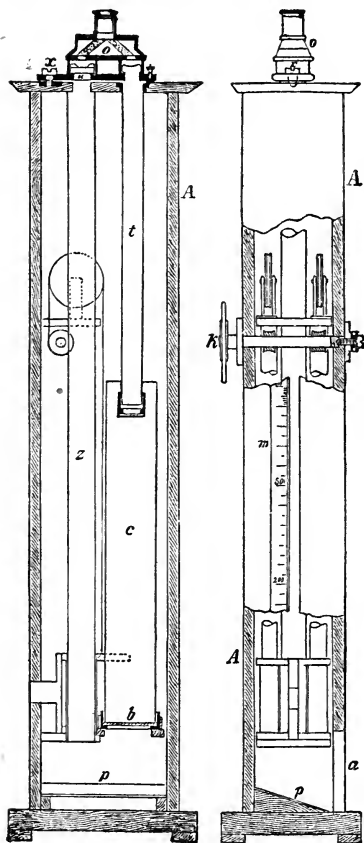

FIG. 221.—STAMMER CHROMOMETER.

A, Case. *a*, Opening for passage of light to reflector. *b*, *c*, Cylinder, with glass bottom, for oil under examination. *k*, Hand-wheel for raising or lowering cylinder, *b*, *c*. *m*, Graduated scale showing length of column of oil through which light is passing. *o*, Optical arrangement (prisms and eyepiece). *p*, Reflector to project light upwards through the parallel tubes and the prisms into the eyepiece. *t*, Tube closed at the bottom by a glass plate. *u*, Coloured glass disc. *x*, Screw on which the optical arrangement may be turned to insert or remove the disc, *u*. *z*, Tube open at both ends.

Stammer's chromometer is now made in an improved form without the wooden case.

The use of the single glass standard provided with this instrument was found by the author to be open to serious objection, as the variations in colour of different samples necessitated the shortening of the column of oil so much in certain cases that the sensitiveness of the test became greatly impaired. Several important modifications introduced by Mr Robert Redwood have, however, overcome this defect, and by means of the improved instrument employed in the author's laboratory it is easy to record accurately the colour of any sample on a scale ranging from "water-white" (1) to standard white (4). The space between any two of the four shades is divided into ten equal parts, so that if the colour, for instance, of a sample is

midway between "water-white" and "superfine white" it would be indicated by the number 1.5.

**Determination of Odour.**—Some experience is required in recording the odour of kerosene, for due consideration must be given to the origin and grade of the oil under examination. The points to be noticed are whether the odour is indicative of imperfect refining, and in the case of oil in barrels, whether the glue used to coat the inner surface of the packages has become decomposed

and imparted an odour to the oil. Usually the odour is reported as "good merchantable" or "not good merchantable."

**Determination of Flashing-Point and Fire-Test.**—The temperature at which a mineral oil, on being slowly heated, begins to evolve vapour in such quantity that on the application of a flame (the "test-flame") a momentary "flash," due to the ignition of the vapour, occurs, is termed the "flashing-point"; and the temperature at which, on being further heated, the oil takes fire on the approach of a flame, and continues burning, is described as the "fire-test" of the sample under examination. The flashing-point is an arbitrary test, the results depending upon the conditions under which the test is made. Most of the instruments constructed for the purpose may be described as belonging either to the "open-test" class, or to the "close-test" class. In the former division the vessel holding the sample of oil is uncovered, and in the latter it is covered during the progress of the experiment. The temperature at which the flashing-point is reached in close-test instruments is usually considerably lower than that at which it is observed in open-test instruments.

The testing of the flashing-point or igniting-point of kerosene is of the greatest importance, and forms the basis of legislation on petroleum in most civilised countries. The customary limitation of specific gravity prevents the introduction of an undue proportion of the heavier hydrocarbons, which would injuriously affect the burning quality of the oil, but affords no security against the presence of very volatile hydrocarbons, which would render the oil unsafe for use in lamps of the ordinary construction. Accordingly, in the early days of the petroleum industry in the United States, it was the practice to test kerosene by pouring it upon a warmed surface, and applying a light, or by heating it in a cup placed in warmed water, and bringing a burning taper near the surface, the flashing-point or fire-test being thus ascertained.

**Tagliabue's Open-Test Instrument.**—When legal restrictions as to the inflammability of kerosene were imposed, special forms of apparatus for determining the flashing-point and fire-test were devised, the earliest of these being the open-test instrument of Giuseppe Tagliabue of New York. This (fig. 222) consists of a glass cup placed in a copper water-bath heated by a spirit lamp. The cup is filled with the oil to be tested, a thermometer placed in it, and heat applied, the temperatures being noted at which on passing a lighted splinter of wood over the surface of the oil, a flash occurs, and, after further heating, the oil ignites.

**Early Legislation in the United Kingdom.**—The Petroleum Act of July 29, 1862, states that "Petroleum, for the purposes of this Act, shall include any product thereof that gives off an inflammable vapour at less than 100° of Fahrenheit's thermometer," but as no method of testing was prescribed, the Act remained practically inoperative. On July 13, 1868, after the subject had been experimentally investigated by Sir Frederick Abel, Dr. Attfield, and Dr. Letheby, an Act was passed which prescribed the form of apparatus and method of testing to be adopted, and defined "petroleum" for the purposes of the two

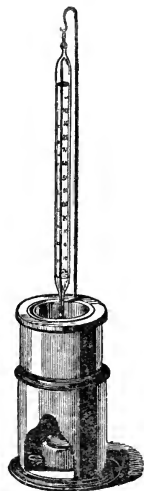

FIG. 222.—TAGLIABUE OPEN TEST.

Acts as including "all such rock oil, Rangoon oil, Burma oil, any product of them, and any oil made from petroleum, coal, schist, shale, peat, or other bituminous substance, and any product of them, as gives off an inflammable vapour at a temperature of less than 100° of Fahrenheit's thermometer." It was at first intended that the oil-cup should be 3 inches in depth and 1½ inch in diameter, and that it should be about one-half filled, but these conditions were subsequently modified. The prescribed apparatus for testing consists of a slightly conical oil-cup of thin sheet-iron, provided with a flat rim, and a raised edge ¼ inch high. Across the cup, and fixed to or resting on the edge, is a wire, which is thus ½ inch above the flat rim. The oil-cup is supported by the rim in a tin water-bath. The outer vessel having been filled with "cold or nearly cold water," as much of the oil to be tested is poured into the cup as will fill it without flowing over the flat rim, and a thermometer with a round bulb, and so graduated that every 10° F. occupies not less than ½ inch on the scale, is then suspended in the oil so that the bulb is immersed about 1½ inch beneath the surface. A screen of pasteboard or wood of specified dimensions having been placed round the apparatus, a "small" flame is applied to the bottom of the water-bath, and when the temperature of the oil has reached 90° F., a "very small" flame is passed across the surface of the oil on a level with the wire, this application of the test-flame being repeated for every rise of "two or three" degrees in temperature, until a "pale-blue flicker or flash" is produced. The temperature at which this occurs having been noted, the experiment is repeated with a fresh sample of the oil, withdrawing the source of heat when the temperature approaches that noted in the first experiment, and applying the test flame at every rise of two degrees. In the use of this apparatus, it was found that oils of 120° F. fire-test, as determined in the United States before shipment, usually had a flashing-point several degrees above the legal limit of 100° F.

**Early Legislation in France.**—The first directions issued in respect of the testing of petroleum in France were contained in the decree of the 31st December 1866. The permissible weight of 1 litre of the oil was not to exceed 800 grams, and the burning-point of the oil was not to be below 35° C. The test of inflammability was to be applied by heating the oil in a copper cup, 6 to 7 centimetres in diameter by 2 to 3 centimetres in depth, in a water-bath, and when a thermometer placed in the oil indicated 35° C., a lighted match was to be drawn across the surface of the oil, and finally plunged into the liquid. If the match was extinguished without igniting the oil, the latter was considered to have passed the test.

**Early Legislation in the United States.**—Most of the earlier petroleum legislation in the United States was based on the fire-test, but in several of the States a flashing-point test was prescribed.

**Squire's Open-Test Apparatus.**—This was designed with a view to the ready adjustment of the test-flame to the required height above the surface of the oil. The oil-cup was heated in a water-bath as usual, but the test-flame was furnished by a wick slightly protruding from a long tube extending from the side of a cylindrical reservoir charged with alcohol. The reservoir was carried by an arm which swung on a vertical rod attached to a heavy base, separate from the water-bath, and the height of it could be adjusted by means of a screw, so that the flame could, by swinging the lamp, be caused to pass over the oil at any desired distance from the surface.

The inventor's directions were:—For 110° oil, the cup should be filled to within one-eighth of an inch from the top, the bulb of the thermometer extended into the oil up to the first cut line, and the height of the test-flame fixed at



three-sixteenths of an inch above the edge of the cup, or five-sixteenths of an inch above the surface of the oil. The apparatus should stand quite level, and the test-flame should be trimmed down to about the size of a dried pea. The heat of the lamp should be so regulated as to raise the temperature of the oil  $5^{\circ}$  in the first four minutes, and afterwards  $10^{\circ}$  every three minutes until  $90^{\circ}$  is reached, at which point the lamp is withdrawn for three minutes to allow the temperature to become stationary (at  $96^{\circ}$  to  $98^{\circ}$ ), when the test-flame is swung, beginning at 2 inches from the cup and terminating at the same distance on the other side, the movement occupying about half a second. If no flash occurs, the test-flame is again swung after a lapse of ten seconds, repeating the operation every two or three degrees until the burning-point is reached. The lamp should be removed before a test is made, until the temperature becomes stationary. For  $120^{\circ}$  oil, the lamp should be allowed to remain until the thermometer indicates  $100^{\circ}$ , the tests being then applied in the manner described, only at every four or five degrees.

**Arnaboldi's Tester.**—An open-cup tester similar to that of Tagliabue, but of somewhat larger size, and provided with a mechanical arrangement for passing the test-flame over the oil, was introduced by Arnaboldi.

**Saybolt's Electric Tester.**—In 1879 the Saybolt electric tester (fig. 223) was adopted by the New York Produce Exchange. In this apparatus the oil is contained in an open cup, and ignition is effected by a spark from an induction-coil passing between platinum points placed at a fixed distance above the oil. The official directions for the use of the apparatus are as follows:—

“Fill the metal bath with water, leaving room for displacement by the glass cup. Heat the water until the bath-thermometer indicates  $100^{\circ}$  F., at which point remove the lamp. Fill the glass cup with oil to top line, indicated by the rim surrounding cup, which is one-eighth of an inch below top edge of the cup. See that there is no oil on the outside of the cup, nor upon the upper level edge, using paper to clean cup in preference to cotton or woollen material. See that the surface of the oil is free from air-bubbles before first flash is produced. Lift the cup steadily with left hand, and place in the bath. Suspend the thermometer with the bulb of same immersed just from view under the surface of oil. Adjust the flashing-bar, and immerse the battery zines in fluid. Try for first flash every degree until the same is obtained. Attain flash by producing spark with one stroke of the key. The stroke on the key should be such as in telegraphy is used to produce what is called a dot, that is a short quick stroke. The first flash produced from  $110^{\circ}$ -test oil is generally obtained when the temperature of the oil has arrived at  $90^{\circ}$ . The temperature of the bath at  $100^{\circ}$  (as per note above) will carry the oil to about  $90^{\circ}$ , or, in other words, to about the first flashing-point, without the aid of a lamp. When the thermometer in the oil indicates  $90^{\circ}$ , introduce lamp under the bath, and do not remove until the operation is finished. The temperature of oil when placed in bath should not be lower than  $55^{\circ}$ , nor higher than  $70^{\circ}$  F.

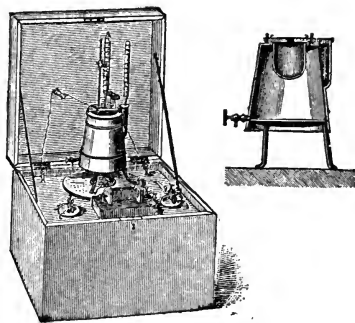

FIG. 223.—SAYBOLT ELECTRIC TESTER.

The flashing-bar must be free from oil before adjusting for test. Draughts of air must be excluded from the apartment wherein tests are made. Oil of 110° and upwards shall (after first flash) be flashed at 95, 100, 104, 108, 110, 112, 115. Oil of 120° and upwards, after first flash, 100, 105, 110, 115, 118, 120, 122, 125. Oil of 130° and upwards, every 5° after first flash, until burning-point."

**Indiana State Test.**—The Indiana State Act of 1881 prescribes the method of applying the open-flash test as follows:—

"The test shall be made in a test-cup of metal or glass, cylindrical in shape, two and one-quarter inches in diameter and four inches deep, both measurements being made inside the cup, and this cup shall be filled to within one-quarter of an inch of the brim with the oil or other substance to be tested. The cup shall be placed in a water-bath sufficiently large to leave a clear space of one inch under the cup, and three-eighths of an inch around it, and in such manner as to project about one-quarter of an inch above the water-bath. The space between the cup and the water-bath shall be nearly filled with cold water, taken at the ordinary temperature, and the cup being placed in the water-bath, the latter shall be heated by an alcohol lamp, with its flame so graduated that the rise in temperature, from 60° F. to the highest test temperature, shall not be less than 2° per minute, and shall be as near 2° per minute as is practicable, and shall in no case exceed 4° per minute. A Fahrenheit thermometer shall be suspended in such manner that the upper surface of its bulb shall be, as near as practicable, one-quarter of an inch below the surface of the oil undergoing the test; as soon as the temperature reaches the point of 98° F., the lamp shall be removed from under the water-bath, and the oil shall then be allowed to rise to the temperature of 100° F. by the residual heat of the water, and at that point the first test for flash shall be made as follows:—A taper, hereinafter described, shall be lighted, and the surface of the oil shall be touched with the flame of the taper, and it shall be lawful to apply this flame either to the centre of the oil surface or to any or all parts of it, but the taper itself shall not be plunged into the oil, and if no flash takes place at the temperature of 100° F., the lamp shall be replaced under the water-bath and the temperature raised to 103°, when the lamp shall be again withdrawn, and allowed to rise to 105° by the residual heat of the water, when the test shall be made at 105° by again applying the flame of the taper, as hereinbefore specified. If no flash occur, the test shall be repeated as often as the oil gains 5° in temperature, 3° with the lamp under the water-bath and 2° with the lamp removed. These tests shall be repeated until a flash is obtained. The inspector shall further test the oil by applying the taper at every 2° rise, without removing the lamp or stirring; but if a flash is obtained by this means by a less rise in temperature than 5° herein required, he shall at once remove the lamp, stir the oil, and immediately apply the flame. The taper used for testing may be made of any wood giving a clear flame, and it shall be made as slender as possible, and with a tip not more than one-sixteenth of an inch in thickness. No taper or match with sulphur on it shall be used, unless the sulphur is first removed before lighting. When the taper is lighted, it shall be applied to the oil immediately—that is to say, before an ash or coal has time to form on the end of the taper beyond the flame, and in applying the taper the flame shall be made to touch the oil, but the taper itself shall not be brought in contact with the oil: Provided that, if the taper is so brought in contact with the oil, but not held there longer than for the space of one second, and the oil flashes, the test shall not thereby be vitiated, but the inspector shall immediately remove the lamp, and again test the oil by the flame, without allowing the body of the taper to touch the oil."

The **Minnesota State** testing instrument also belongs to the open-test class.

**Danish Tester.**—An instrument similar to that of Tagliabue, but with an oil-cup made of copper, is described<sup>1</sup> as the *Danish Tester*, and is said to be the instrument at one time officially used in Denmark. In carrying out the test the water-bath is filled with water to a mark, the oil-cup is inserted and filled with oil up to a mark, and the thermometer is placed in such a position that its bulb is just covered by the oil. The temperature is gradually raised, and from time to time, a small flame—that of a wooden match, for example—is brought within a short distance of the surface of the oil (care being taken not to touch either the oil or the walls of the cup), until a flash is observed. In repeating the test, the oil-cup must be cooled before being filled with a fresh portion of the oil, and the water-bath recharged with cold water.

**Defects in the English Legal Test of 1868.**—It was soon found that the directions for testing given in the English Petroleum Act of 1868 were not sufficiently precise, and that the words “small flame” and “very small flame” were differently interpreted by various operators. As the result, dealers were frequently proceeded against, and sometimes convicted, for selling kerosene flashing below the legal limit, although the oil had been passed by independent experts. Moreover, it was found that the open-cup tests were very untrustworthy, especially when made by comparatively unskilled and inexperienced persons.

**Keates's Close Test Instrument.**—The substitution of a closed or covered oil-cup (fig. 224) for the open cup was accordingly proposed by Mr. Keates, consulting chemist of the Metropolitan Board of Works. In 1871 a bill to legalise this change and to otherwise amend the existing law was introduced, but it was opposed by the petroleum trade on the ground that the flashing-point of 85° F. advocated by Mr. Keates was much higher than the equivalent of the standard of 100° F. in use with the open cup.

**The Act of 1871.**—The Act passed on 11th August 1871, although repealing the two last Acts (see the section on Legislation), did not, therefore, effect any alteration in the mode of testing, but prescribed the use of the open cup as specified in the Act of 1868.

**The Select Committee of 1872.**—In the following year a Select Committee of the House of Lords inquired into the subject of petroleum-testing, but arrived at no definite conclusions.

**Reference to Sir Frederick Abel.**—In 1875 the Government, with the concurrence of the Metropolitan Board of Works and of the Petroleum Association, requested Sir Frederick Abel to experimentally investigate the matter, with a view to placing it on a satisfactory basis. The questions referred were as follows:—

“1. Whether the method of testing petroleum as prescribed in Schedule 1 of the Petroleum Act, 1871 (34 and 35 Vict., c. 105), is such as uniformly to ensure reliable and satisfactory results.

“2. If not, what alterations in the method of testing petroleum should be adopted to secure such results, due regard being had to the fact that the testing must, in many instances, be carried out by persons who have had comparatively little experience in conducting delicate experiments.

<sup>1</sup> *Zeitschr. anal. Chemie*, xx, 11 (1881).

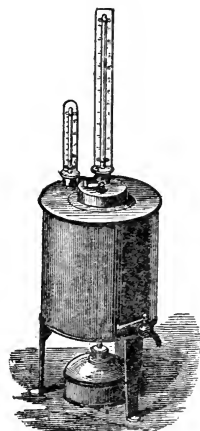

FIG. 224.—KEATES'S CLOSE TEST.

"3. Assuming it to be, in your opinion, desirable to obtain a 'flashing test' for petroleum, whether the present 'flashing-point' of 100° F. (or its equivalent under any modified method of testing which you may propose) is, in your judgment, calculated to afford adequate protection to the public, without unduly interfering with or restricting the trade; if not, what alteration in this respect should be made."

After a prolonged and exhaustive experimental inquiry, in which Dr. Kellner rendered valuable assistance, Sir Frederick Abel presented to the Secretary of State an elaborate report, dated 12th August 1876, wherein the questions enumerated were thus answered:—

"1. The method of testing petroleum as prescribed in Schedule 1 of the Petroleum Act, 1871 (34 and 35 Vict., c. 105), is not of a nature 'uniformly to ensure reliable and satisfactory results.'

"2. A method of testing petroleum has been elaborated for adoption in place of that prescribed by the Petroleum Act, 1871, due regard having been had to the fact 'that the testing must, in many instances, be carried out by persons who have had comparatively little experience in conducting delicate experiments.' This method, while resembling in its general nature the one hitherto used, is free from the defects inherent in the latter, and is so arranged that it can be carried out, with the certainty of furnishing uniform and precise results, by persons possessing no special knowledge or skill in manipulation. With ordinary attention in the first instance to simple instructions, different operators cannot fail to obtain concordant results with it, and it is so nearly automatic in its nature that it is not, like the present method of testing, susceptible of manipulation so as to furnish different results at the will of the operator.

"3. There are not, in my judgment, any well-established grounds for considering that the present flashing-point of 100° F. is not 'calculated to afford adequate protection to the public.'

"4. With the employment of the new test, a minimum flashing-point should therefore be adopted, which is equivalent, or as nearly as possible so, to the flashing-point of 100° F., as furnished by the present test."

In the determination of the equivalent flashing-point, it was obviously necessary to deal with the conflicting views already referred to, as to the proper mode of conducting the test with the open-cup instrument. The author was enabled to assist Sir Frederick Abel in the conduct of this portion of the inquiry, but before the test standard was even provisionally fixed, Mr. T. W. Keates, as representing the Metropolitan Board of Works, and Mr. John Calderwood, on behalf of the Scottish Mineral Oil Association, were also consulted. Eventually, as the result of the joint experiments, it was ascertained that the difference between the flashing-points obtained with the open-cup instrument and those furnished by the Abel apparatus usually ranged from 25° to 29° F. Adopting the mean difference of 27°, the new standard was accordingly fixed at 73° F. The author then applied the two tests to 1000 samples of American kerosene, the first 968 samples consisting of the ordinary oil of commerce, and the remaining 32 of "water-white" oil. The following were the results obtained:—

92 samples showed a difference between the two tests of 25°			
208	"	"	26°
225	"	"	27°
281	"	"	28°
162	"	"	29°
<hr/>			
968			

On the other hand, the majority of the last 32 samples gave smaller differences, as follows:—

9 samples	showed a difference between the two tests of	20°
1 sample	“	“
9 samples	“	“
1 sample	“	“
4 samples	“	“
8 samples	“	“

—  
32

These, however, all consisted, not of ordinary petroleum oil, but of the special kind which is known in the trade under the name of “water-white oil,” and, therefore, the exceptional results afforded by them do not affect the question at issue, and are of interest only as showing that samples may be selected or specially prepared having flashing-points by the two systems more closely approximating than those of the ordinary petroleum oil of commerce. This “water-white oil,” as is well understood, possesses the distinctive feature of low specific gravity in addition to that of high flashing-point, being, in fact, produced at a considerably enhanced cost, by rejecting, in the process of distilling the crude oil, an unusually large proportion of the heavier as well as the lighter hydrocarbons, and doubtless this accounts for the smaller differences between the two tests.

Before the new test was legalised, the author proceeded (in 1877) to New York for the purpose of submitting the instrument to the inspectors appointed by the New York Produce Exchange, and arranging for its use in testing kerosene intended for shipment to this country.

**The Abel Test.**—The result of Sir Frederick's investigation was the legalisation, on 11th August 1879, of the “Abel test.” The instrument and its use are thus described in the Petroleum Act of that date:—

### FIRST SCHEDULE.

MODE OF TESTING PETROLEUM SO AS TO ASCERTAIN THE TEMPERATURE AT WHICH IT WILL GIVE OFF INFLAMMABLE VAPOUR.

**Specification of the Test Apparatus** (fig. 225).—The following is a description of the details of the apparatus:—

“The oil-cup consists of a cylindrical vessel 2 inches diameter,  $2\frac{2}{10}$  inches height (internal), with outward projecting rim  $\frac{5}{10}$  inch wide,  $\frac{3}{8}$  inch from the top, and  $1\frac{7}{8}$  inch from the bottom of the cup. It is made of gun-metal or brass (17 B.W.G.), tinned inside. A bracket, consisting of a short stout piece of wire bent upwards, and terminating in a point, is fixed to the inside of the cup to serve as a gauge. The distance of the point from the bottom of the cup is  $1\frac{1}{2}$  inch. The cup is provided with a close-fitting overlapping cover made of brass (22 B.W.G.), which carries the thermometer and test-lamp. The latter is suspended from two supports from the side by means of trunnions, upon which it may be made to oscillate; it is provided with a spout, the mouth of which is  $\frac{1}{16}$  inch diameter. The socket which is to hold the thermometer is fixed at such an angle and its length is so adjusted that the bulb of the thermometer, when inserted to its full depth, shall be  $1\frac{1}{2}$  inch below the centre of the lid.

“The cover is provided with three square holes—one in the centre,  $\frac{5}{10}$  inch by  $\frac{4}{10}$  inch, and two smaller ones,  $\frac{3}{10}$  inch by  $\frac{2}{10}$  inch, close to the sides and opposite each other. These three holes may be closed and uncovered by

means of a slide moving in grooves, and having perforations corresponding to those on the lid.

“In moving the slide so as to uncover the holes, the oscillating lamp is caught by a pin fixed in the slide, and tilted in such a way as to bring the end of the spout just below the surface of the lid. Upon the slide being pushed back so as to cover the holes, the lamp returns to its original position.

“Upon the cover, in front of and in line with the mouth of the lamp, is fixed a white bead, the dimensions of which represent the size of the test-flame to be used.

“The bath or heating-vessel consists of two flat-bottomed copper cylinders

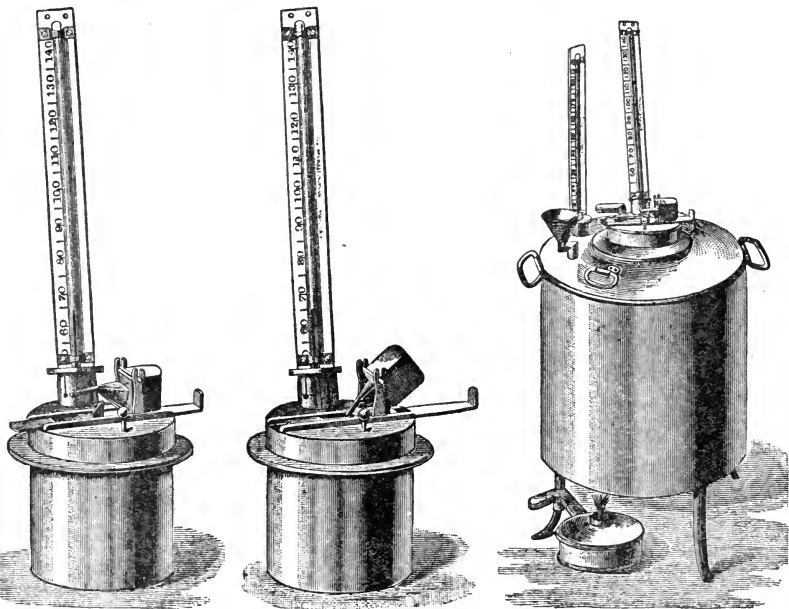

FIG. 225.—ABEL TEST APPARATUS.

(24 B.W.G.)—an inner one of 3 inches diameter and  $2\frac{1}{2}$  inches in height, and an outer one of  $5\frac{1}{2}$  inches diameter and  $5\frac{3}{4}$  inches in height; they are soldered to a circular copper plate (20 B.W.G.) perforated in the centre, which forms the top of the bath, in such a manner as to enclose the space between the two cylinders, but leaving access to the inner cylinder. The top of the bath projects both outwards and inwards about  $\frac{3}{8}$  inch; that is, its diameter is about  $\frac{6}{8}$  inch greater than the body of the bath, while the diameter of the circular opening in the centre is about the same amount less than that of the inner copper cylinder. To the inner projection of the top is fastened, by six small screws, a flat ring of ebonite, the screws being sunk below the surface of the ebonite to avoid metallic contact between the bath and the oil-cup. The exact distance between the sides and bottom of the bath and of the oil-

cup is  $\frac{1}{2}$  inch. A split socket similar to that on the cover of the oil-cup, but set at a right angle, allows a thermometer to be inserted into the space between the two cylinders. The bath is further provided with a funnel, an overflow-pipe, and two loop handles.

"The bath rests upon a cast-iron tripod stand, to the ring of which is attached a copper cylinder or jacket (24 B.W.G.) flanged at the top, and of such dimensions that the bath, while firmly resting on the iron ring, just touches with its projecting top the inward-turned flange. The diameter of this outer jacket is  $6\frac{1}{2}$  inches. One of the three legs of the stand serves as a support for the spirit-lamp attached to it by means of a small swing bracket. The distance of the wick-holder from the bottom of the bath is 1 inch.

"Two thermometers are provided with the apparatus—the one for ascertaining the temperature of the bath, the other for determining the flashing-point. The thermometer for ascertaining the temperature of the water has a long bulb and a space at the top. Its range is from about  $90^{\circ}$  to  $190^{\circ}$  F. The scale (in degrees of Fahrenheit) is marked on an ivory back fastened to the tube in the usual way. It is fitted with a metal collar, fitting the socket, and the part of the tube below the scale should have a length of about  $3\frac{1}{2}$  inches, measured from the lower end of the scale to the end of the bulb. The thermometer for ascertaining the temperature of the oil is fitted with collar and ivory scale in a similar manner to the one described. It has a round bulb, a space at the top, and ranges from about  $55^{\circ}$  F. to  $150^{\circ}$  F.; it measures, from end of ivory back to bulb,  $2\frac{1}{4}$  inches.

"NOTE.—A model apparatus is deposited at the Weights and Measures Department of the Board of Trade.

### "DIRECTIONS FOR APPLYING THE FLASHING-TEST.

"1. The test-apparatus is to be placed for use in a position where it is not exposed to currents of air or draughts.

"2. The heating vessel or water-bath is filled by pouring water into the funnel until it begins to flow out at the spout of the vessel. The temperature of the water at the commencement of the test is to be  $130^{\circ}$  F., and this is attained in the first instance either by mixing hot and cold water in the bath, or in a vessel from which the bath is filled, until the thermometer which is provided for testing the temperature of the water gives the proper indication; or by heating the water with the spirit-lamp (which is attached to the stand of the apparatus) until the required temperature is indicated.

"If the water has been heated too highly, it is easily reduced to  $130^{\circ}$  by pouring in cold water little by little (to replace a portion of the warm water) until the thermometer gives the proper reading.

"When a test has been completed, this water-bath is again raised to  $130^{\circ}$  by placing the lamp underneath, and the result is readily obtained while the petroleum-cup is being emptied, cooled, and refilled with a fresh sample to be tested. The lamp is then turned on its swivel from under the apparatus, and the next test is proceeded with.

"3. The test-lamp is prepared for use by fitting it with a piece of flat plaited candle-wick, and filling it with colza or rape oil up to the lower edge of the opening of the spout or wick-tube. The lamp is trimmed so that when lighted it gives a flame of about 0.15 of an inch diameter, and this size of flame, which is represented by the projecting white bead on the cover of the oil-cup,<sup>1</sup>

<sup>1</sup> It was at first intended merely to specify the size of the flame, but as it was found difficult to judge of the diameter, the bead was added at the suggestion of the author.

is readily maintained by simple manipulation from time to time with a small wire trimmer.

“When gas is available it may be conveniently used in place of the little oil-lamp, and for this purpose a test-flame arrangement for use with gas may be substituted for the lamp.

“4. The bath having been raised to the proper temperature, the oil to be tested is introduced into the petroleum-cup, being poured in slowly until the level of the liquid just reaches the point of the gauge which is fixed in the cup. In warm weather the temperature of the room in which the samples to be tested have been kept should be observed in the first instance, and if it exceeds 65°, the samples to be tested should be cooled down (to about 60°) by immersing the bottles containing them in cold water, or by any other convenient method. The lid of the cup, with the slide closed, is then put on, and the cup is placed into the bath or heating vessel. The thermometer in the lid of the cup has been adjusted so as to have its bulb just immersed in the liquid, and its position is not, under any circumstances, to be altered. When the cup has been placed in the proper position, the scale of the thermometer faces the operator.

“5. The test-lamp is then placed in position upon the lid of the cup, the lead-line or pendulum, which has been fixed in a convenient position in front of the operator, is set in motion, and the rise of the thermometer in the petroleum cup is watched. When the temperature has reached about 66°, the operation of testing is to be commenced, the test-flame being applied once for every rise of one degree in the following manner:—

“The slide is slowly drawn open while the pendulum performs three oscillations, and is closed during the fourth oscillation.

“NOTE.—If it is desired to employ the test-apparatus to determine the flashing-point of oils of very low volatility, the mode of proceeding is to be modified as follows:—

“The air-chamber which surrounds the cup is filled with cold water to a depth of 1½ inch, and the heating vessel or water-bath is filled as usual, but also with cold water. The lamp is then placed under the apparatus, and kept there during the entire operation. If a very heavy oil is being dealt with, the operation may be commenced with water previously heated to 120°, instead of with cold water.”

The pendulum described in (5) measures 24 inches from the point of suspension to the centre of gravity of the weight. The author has found it convenient to employ a synchronised pendulum clock, or a metronome, when making a large number of tests.

The Abel instruments employed in the United Kingdom by the inspectors appointed in accordance with the provisions of the Petroleum Acts are standardised by the Weights and Measures Department of the Board of Trade.

The Petroleum Act, 1879, gives no specific directions applicable to the testing of indiarubber solution, and to meet this deficiency the first schedule of the Inflammable Liquids Bill, 1891, contained the following addition to the instructions for the use of the test apparatus:—

“If the flashing-test has to be applied to substances of a viscous or semi-solid nature which cannot be poured (such as solutions of indiarubber in mineral naphtha), the mode of proceeding is as follows:—About a table-spoonful of the substance to be tested is placed in the cup, and the cover is put on. The air-chamber in the water-bath is filled with water to a depth of 1½ inch, and the temperature of the water-bath is raised to 76° (for which purpose the scale of the thermometer to be used in the water-bath should range from 60° to 180°).



"The cup is then put into the bath, and the temperature of the water-bath maintained at 76° throughout the test. After the lapse of fifteen minutes the test-flame is to be applied. If no flash occurs, the heating is continued for another fifteen minutes, and the test-flame again applied; and so on until a flash takes place, or the temperature in the cup has reached 75°; [if a flash occurs at or] below 72° the substance under examination has an observed flashing-point of less than 73°. The temperature at which a flash occurs is the observed flashing-point of the substance, and, subject to correction for atmospheric pressure as hereinbefore described, is the true flashing-point."

Although some paints containing petroleum, such as anti-fouling and anti-corrosion compositions applied to ships' bottoms, and some compounds used as liquid metal polish, are neither viscous nor semi-solid and can be poured, their flashing-points cannot be satisfactorily determined in the manner prescribed for the testing of petroleum owing to their being insufficiently fluid to admit of the formation of convection currents. In other words, the heat applied by means of the water-bath and air-jacket does not circulate freely through the contents of the oil-cup, with the result that the part of the liquid undergoing the test which is in contact with the walls of the cup acquires a much higher temperature than is indicated by the thermometer, and a flashing-point may be thus recorded which is far below the true flashing-point. For the efficient testing of such liquids a stirrer in the oil-cup is needed.

The following semi-official memorandum on this subject was published in *The Times* of 17th May 1904:—

"*Petroleum Acts.*—It has recently come to our knowledge that attempts are being made by officers of local authorities to apply the legal test for petroleum to samples of liquid metal-polish, and we have satisfied ourselves by experiment that the results thus obtained are sometimes entirely misleading, as they do not represent the temperature of the portion of the liquid from which inflammable vapour is being evolved.

"In carrying out the test prescribed by the Petroleum Act, 1879, the sample under examination is slowly heated in a closed cup, and the temperature is indicated by a thermometer, the bulb of which is immersed in the liquid in the centre of the vessel. In these circumstances, the heat communicated to the sample through the walls of the cup creates, in such a liquid as petroleum, convection currents, and through the circulation thus set up the temperature of the contents of the cup is equalised, and the thermometer correctly indicates the temperature at which inflammable vapour is evolved by the liquid.

"On the other hand, if the sample contains solid matter in suspension, as is the case with the liquid metal-polish in question, the formation of convection currents is interfered with, and the surface of the liquid from which inflammable vapour is evolved acquires a higher temperature than that of the portion in contact with the bulb of the thermometer. Thus, as we have ascertained experimentally, the thermometer may indicate a temperature of 59° F., when the temperature of the surface is 83° F., and a sample may be erroneously reported as having a flash-point below the legal limit of 73° F., when the true flash-point is far above the limit.

"No doubt this would have been provided for when the Act was passed, if, at that time, the need for applying the test to such substances had been foreseen, but it was not until judgment in the case of 'The London County Council v. Holzapfels Compositions Company, Limited,' was given in 1899 that mixtures containing petroleum were held to be petroleum within the meaning of the Acts.

"In our Handbook on Petroleum, published in 1901, we referred, on page

<sup>1</sup> The words in square brackets have apparently been inadvertently omitted.

90, to the necessity for a stirrer in the oil-cup when the test specified in the Petroleum Act is employed for the testing of paints and other substances containing petroleum, and when opportunity occurs for a revision of the law this addition will doubtless be legalised.

“ We are, however, of opinion that, in the meantime, authorities charged with the administration of the Petroleum Acts should be made aware of the circumstances we have referred to, and that testing officers should take steps to ascertain the true flash-point of samples of liquid metal-polish or other substances which are not thoroughly liquid, and, therefore, cannot be satisfactorily tested in precise accordance with the directions given in the schedule to the Act. In many instances it may be possible to obtain a sample of the petroleum used in the substance, or the solid matter present in the sample can be removed by straining or filtration, care being taken to avoid loss of the more volatile constituents by evaporation, when the separated liquid can be tested in the prescribed manner. The liquid should not, however, be separated by distillation, as this operation may yield a distillate of lower flash-point than that of the petroleum with which the mixture was made. For guidance in determining whether there has been any infraction of the law, the sample may also be tested in an apparatus provided with an efficient stirrer. In any case of doubt as to the true flash-point of the material, we would suggest that reference should be made to His Majesty’s Inspectors of Explosives, at the Home Office, who will be prepared to give advice as to the course which should be adopted.

“ J. H. THOMSON, Captain, H.M. Chief  
Inspector of Explosives.

“ BOVERTON REDWOOD, Adviser on  
Petroleum to the Home Office.”

“ 30th April 1904.”

By an Order in Council, dated 7th May 1907, it was directed that certain portions of the Petroleum Acts, 1871 to 1881, shall apply to mixtures of petroleum, and the following instructions for testing were given :—

#### “ DIRECTIONS FOR TESTING PETROLEUM MIXTURES.

“ 1. **Liquid Mixtures.**—Where the Petroleum Mixture is wholly liquid, flows quite freely, and does not contain any sediment or thickening ingredient, such mixture shall be tested in the manner set forth in Schedule One to the Petroleum Act, 1879.

“ 2. **Viscous and Sedimentary Mixtures.**—Where the Petroleum Mixture contains an undissolved sediment, as in the case of some metal polishes, which can be separated by filtration or by settlement and decantation, the sediment may be so separated and the decanted liquid may be tested in the manner set forth in Schedule One to the Petroleum Act, 1879.

“ In carrying out such separation, care must be taken to minimise the evaporation of the petroleum. The separation of the sediment must not be effected by distillation.

“ Where the Petroleum Mixture is such that sediment cannot be separated by the aforementioned means, or where it is of a viscous nature, as in the case of indiarubber solution, quick-drying paints, etc., such mixture shall be tested in the apparatus modified as shown in the drawing hereto (fig. 226). This apparatus differs from that prescribed in Schedule One to the Petroleum Act, 1879, only in the addition of a stirrer to equalise the temperature throughout the sample under test.

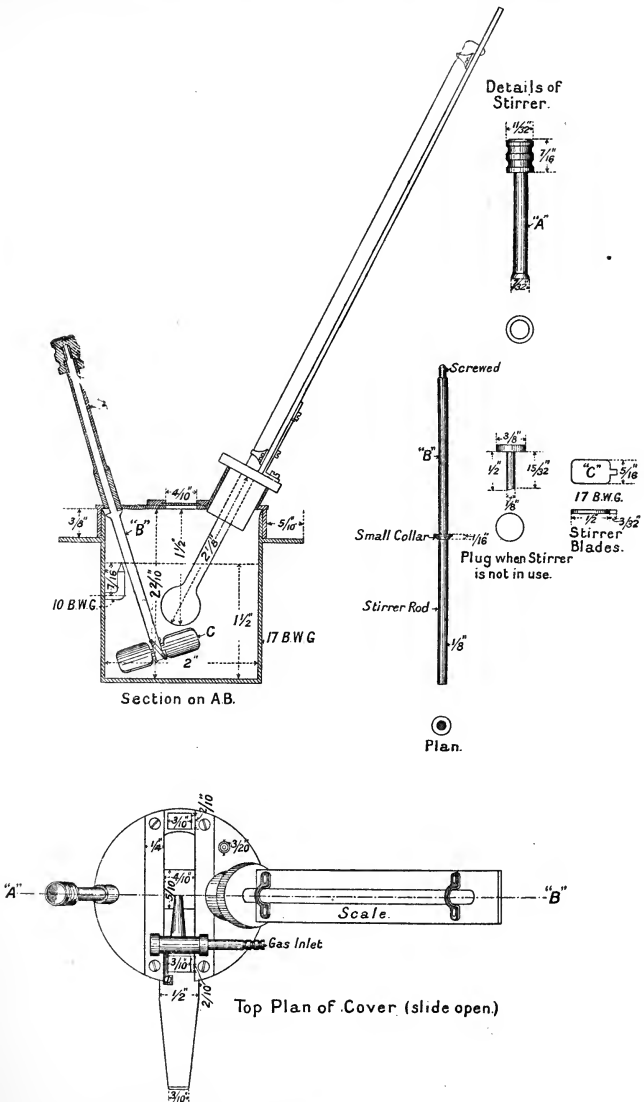

FIG. 226.—MODIFIED ABEL'S CUP WITH STIRRER.

"In carrying out the test of a viscous petroleum mixture, this stirrer shall be constantly revolved at a slow speed, except when applying the test flame, with the fingers, the direction of revolution being that of the hand of a clock.

"With the exception of the use of the stirrer, the manner of carrying out the test shall be that set forth in Schedule One to the Petroleum Act, 1879.

"The stirrer may be removed by grasping the spindle just above the blades with the finger and thumb, and unscrewing the upper sheath. The opening in the lid, through which the stirrer passes, may then be closed by a plug provided for the purpose.

"When this has been done, the apparatus shall be deemed to comply with the specification set forth in Schedule One of the Petroleum Act, 1879, and may be used for testing ordinary petroleum or solid petroleum mixtures.

"A model of the aforementioned apparatus will be deposited with the Board of Trade, and the provisions of Section 3 of the Petroleum Act, 1879, in regard to verification and stamping shall apply also to such apparatus as though it were the apparatus prescribed by the said Act.

"For the purpose of carrying out such verification the stirrer shall be removed and the opening plugged as hereinbefore directed. The apparatus shall then be tested with ordinary petroleum. The stirrer shall be verified by comparison of measurements.

**3. Solid Petroleum Mixtures.**—Where the Petroleum Mixture is solid, as in the case of naphtha soaps, etc., the apparatus to be used for the test shall be that prescribed in Schedule One of the Petroleum Act, 1879.

"The method of carrying out the test of such solid mixture shall be as follows:—

"The solid mixture must be cut into cylinders  $1\frac{1}{2}$  inch long and  $\frac{1}{4}$  inch in diameter by means of a cork borer or other cylindrical cutter having the correct internal diameter. These cylinders are to be placed in the petroleum cup of the testing apparatus in a vertical position in such numbers as will completely fill the cup. The cylinders must be in contact with one another, but must not be so tightly packed as to be deformed in shape.

"Five or six of the cylinders in the centre of the cup must be shortened to  $\frac{1}{2}$  inch to allow space for the thermometer bulb.

"The air-bath of the testing-apparatus must be filled to a depth of  $1\frac{1}{2}$  inch with water. The water-bath must then be raised to and maintained at a temperature of about  $75^{\circ}$  Fahrenheit.

"The cup must then be placed in the air-bath, and the temperature of the sample must be allowed to rise until the thermometer in the oil-cup shows  $72^{\circ}$  Fahrenheit, when the test flame must be applied.

"If no flash is obtained, this temperature must be maintained constant in the oil-cup for one hour, at the expiration of which time the test flame must again be applied.

"If a flash is obtained, the solid mixture will be subject to the provisions of the Petroleum Acts in virtue of this Order.

**NOTE.**—It may in many cases save time in testing samples of petroleum mixtures to apply the test flame after the sample has been a few minutes in the cup and while still at the temperature of the room in which the test is being carried out, provided that this temperature is below  $73^{\circ}$  Fahrenheit. If a flash is obtained by this means, it is unnecessary to proceed with the test at a higher temperature."

**Effect of Variations in Barometric Pressure.**—It was soon found that the results obtained with the Abel instrument differed materially according to the barometric pressure at the time of testing. This source of variation appears to

have been first observed accidentally in Germany, and as the result of a series of experiments made in an airtight chamber in the Jewish Hospital in Berlin, it was ascertained that the difference in the flashing-point amounted to about 0.30° C. for each 10 millimetres difference in the barometric column. A table of corrections was accordingly prepared in Germany for use with the Abel-Pensky tester, as described on pp. 788, 789, and 791.

**Experiments at Different Altitudes in Switzerland.**—To obtain further evidence as to the effect of alteration in barometric pressure on the flashing-point, a series of experiments was conducted by the author in consultation with Sir Frederick Abel at different altitudes in Switzerland, and results exhibiting a difference of about 2° F. in the flashing-point for 1 inch difference in barometric pressure were obtained.

The experiments were, however, not carried out with a view of determining the exact extent of variation, the number of tests made being insufficient to form the basis of a table of corrections. The results actually obtained are given in the following table:—

TABLE CXXXV.—RELATION OF FLASHING-POINT TO BAROMETRIC PRESSURE.

No. of Sample.	London. Bar. at 30".	Paris. 30.15".	Bouveret. 28.15".	Visp. 27.5".	Chamounix 26.425".	Zermatt. 24.3".	Riffel. 21.5".
1	71° F.	71° F.	68° F.	66° F.	63° F.	60° F.	55° F.
2	73	73	70	68	64	62	56
3	76	76	73	71	68	65	63
4	78	78	75	73	70	67	64
5	85	85	83	80	78	75	70
Difference in barometer from London observation,			1.25"	2.5"	3.575"	5.7"	8.5"
Mean difference in flashing- point per inch of mercurial column,			2.05°	2°	2.238°	1.93°	1.76°

**Effect of a Tropical Climate.**—It was also found that the effect of a tropical climate upon the liberation of vapour from the oil resulted in the flashing-point being considerably lowered, and as the Indian Government, in adopting the Abel test, had copied the directions verbatim from the English Act, the result was that several cargoes of oil, which were certified as of proper flashing-point at the time of shipment, were refused admittance at the port of Calcutta.

**Experimental Investigations in India and in London.**—In order to investigate the matter, the author proceeded to India, and from a series of experiments made there and afterwards in England in conjunction with Sir Frederick Abel, and with the assistance of Dr. Kellner, it was demonstrated that a much lower flashing-point than that furnished in a temperate climate was liable to be obtained when the Abel test was employed in a tropical climate in the manner prescribed in the English Act. Further experiments made by Dr. Warden, analyst to the Government of Bengal, Prof. (now Sir Alexander) Pedler, Dr. Lyon, Sir Frederick Abel, Dr. Kellner, and the author, showed that the depression in the flashing-point was largely due to disengagement of vapour in the act of filling the oil-cup. Although prolonged cooling of the oil minimised the liability to such disengagement of vapour, it was found that the only practical means of eliminating this source of error was to get rid of the vapour before commencing the test or before the flashing-point was reached.

**Modifications Proposed.**—The vapour was readily removed by gently blowing over the surface of the oil before placing the cover on the cup, or by the use of an aspirator attached to the cover, or by leaving the test-slide withdrawn for some time; but the method finally adopted consisted in commencing the test many degrees below the flashing-point, so that the vapour is withdrawn by the current of air created by the test-flame, in successive quantities too small to cause a flash before active volatilisation of the oil begins. Thus modified, the test gives results at a tropical temperature which agree very closely with those which it furnishes in a temperate climate. The slight loss of volatile constituents which occurs when the test is so performed is of no practical importance, since such loss takes place even by exposure to the air in hot climates (see a joint communication from Sir F. Abel and the author in the *Chemical News*, 2nd May 1884).

**Directions for Conducting the Test in Temperate Climates.**—In October 1887 Sir Frederick Abel drew up the following directions for the use of the Abel instrument in *temperate* climates:—

### “DIRECTIONS FOR PREPARING AND USING APPARATUS FOR TESTING PETROLEUM OIL.

“ (*These Directions apply to the use of the Abel tester in temperate climates.*)

“ 1. **Preparing the Water-Bath.**—The water-bath is filled by pouring water into the funnel until it begins to flow out at the overflow-pipe. The temperature of the water at the commencement of each test, as indicated by the long-bulb thermometer, is to be 130° F., and this is attained in the first instance by mixing hot and cold water, either in the bath or in the vessel from which the bath is filled, until the thermometer which is provided for testing the temperature of the water gives the proper indication; or the water is heated by a spirit-lamp (which is attached to the stand of the apparatus) until the required temperature is reached.

“ 2. **Preparing the Test-Lamp.**—The test-lamp is fitted with a piece of cylindrical wick of such thickness that it fills the wick-holder, but may readily be moved to and fro for the purpose of adjusting the size of the flame. In the body of the lamp, upon the wick, which is coiled within it, is placed a small tuft of cotton-wool moistened with petroleum, any oil not absorbed by the wool being removed. When the lamp has been lighted the flame is adjusted until it is the size of the bead fixed on the cover of the oil-cup.

“ 3. **Filling the Oil-Cup.**—The oil-cup is placed on a level surface in a good light, and the oil to be tested is poured in without splashing, until its surface is level with the point of the gauge which is fixed in the cup. The oil should be poured from a suitable small vessel, never direct from a large can. The round-bulb thermometer is inserted into the lid of the cup, care being taken that the projecting rim of the collar touches the edge of the socket; the test-lamp, prepared as already described, is placed in position, and the cover put on to the cup and pressed down so that its edge rests on the rim of the cup.

“ 4. **The Application of the Test.**—The water-bath, with its thermometer in position, is placed in some locality where it is not exposed to currents of air, and where the light is sufficiently subdued to admit of the size of the test-flame being compared with that of the bead on the cover. The cup is carefully lifted without being shaken, placed in the bath, and the test-lamp lighted. The thermometer in the oil-cup is now watched, and when the temperature has

reached 66° F. (the sample, if necessary, having previously been cooled to below that temperature by immersing the vessel containing it in cold water), the operation of testing is to be commenced, the test-flame being applied for every rise of one degree.

“ If the oil-cup is provided with the automatic (Pensky’s) arrangement for opening and shutting the slide, the clockwork is wound up by turning the knob from left to right, and set in motion by pressing the trigger.<sup>1</sup>

“ If the slide is intended to be moved by hand, it should be drawn open slowly and shut quickly. The exact time to be observed in this operation is regulated by the swing of the pendulum supplied with this form of instrument. The opening of the slide should take the time of three oscillations, the shutting of the slide the time of the fourth oscillation of the pendulum. (By one oscillation is meant the passage of the ball of the pendulum from the greatest distance from the vertical on the one side to the greatest distance on the other.)

“ If a flash occurs at the first application of the test-flame (at 66° F.), or at any point below 73° F., the operation is to be repeated with a fresh portion of the oil, which is cooled down to 55° F. before being placed in the cup. The first application of the test-flame is made when the temperature of the oil has reached 60° F.

“ In repeating a test, a fresh sample of oil must always be used, the tested sample being thrown away.

“ **Correction for Atmospheric Pressure.**—As the flashing-point of an oil is influenced by changes in atmospheric pressure to an average extent of 1.6° F. for every inch of the barometer, a correction of the observed flashing-point may become necessary. The height of the barometer must, therefore, be determined at the time of making the test for the flashing-point. An aneroid barometer is supplied for this purpose. To facilitate the correction of a flashing-point for pressure a table is appended (see Table CXXXVI), giving the flashing-points of oils ranging from 65° to 80° F. under pressures ranging from 27 to 31 inches of mercury.

“ The table is used in the following manner:—

“ *Example.*—An oil has given a flashing-point of 71°, the barometer being 28.6; take the nearest number to 71° in the vertical column headed 28.6. This number is 70.8. Substitute for this number in the same horizontal line in the column headed 30 (the normal height of barometer). The substituted number—*i.e.* the true flashing-point of the oil—is 73°.”

**Legislation in India.**—The Indian Petroleum Act, 1899, of which an abstract will be found in the section dealing with Legislation, gave power to the Governor-General in Council to alter or add to the prescribed tests. The schedule relating to testing, as modified up to 1st November 1903, is given in full in the following paragraphs. Since the Abel test was legalised in India, it has been found necessary to determine the flashing-point of Burma crude petroleum which is solid at common temperatures. In testing this oil in the Abel instrument, active evolution of vapour commences while the bulk of the oil in the cup remains solid, and the thermometer therefore does not indicate the temperature of the oil in contact with the walls of the cup from which vapour is being evolved. To meet this difficulty, the author suggested the addition of a sensitive thermometer, which is fixed in the cover of the oil-cup in a vertical position, so that the small cylindrical bulb is just immersed in the oil, and is distant only a tenth of an inch from the side of the cup. This modification has been adopted.

<sup>1</sup> This refers to the Abel-Pensky apparatus, described on pp. 785, 786, 787.

TABLE CXXXVI.—FOR CORRECTION OF FLASHING-POINTS INDICATED BY THE TEST, FOR VARIATIONS IN BAROMETRIC PRESSURE ON EITHER SIDE OF THIRTY INCHES.  
Barometer in Inches.

	27	27.2	27.4	27.6	27.8	28	28.2	28.4	28.6	28.8	29	29.2	29.4	29.6	29.8	30	30.2	30.4	30.6	30.8	31
60.2	60.5	60.8	61.2	61.5	61.8	62.1	62.4	62.8	63.1	63.4	63.7	64	64.4	64.7	65	65.3	65.6	66	66.3	66.6	66.6
61.2	61.5	61.8	62.2	62.5	62.8	63.1	63.4	63.8	64.1	64.4	64.7	65	65.4	65.7	66	66.3	66.6	67	67.3	67.6	67.6
62.2	62.5	62.8	63.2	63.5	63.8	64.1	64.4	64.8	65.1	65.4	65.7	66	66.4	66.7	67	67.3	67.6	68	68.3	68.6	68.6
63.2	63.5	63.8	64.2	64.5	64.8	65.1	65.4	65.8	66.1	66.4	66.7	67	67.4	67.7	68	68.3	68.6	69	69.3	69.6	69.6
64.2	64.5	64.8	65.2	65.5	65.8	66.1	66.4	66.8	67.1	67.4	67.7	68	68.4	68.7	69	69.3	69.6	70	70.3	70.6	70.6
65.2	65.5	65.8	66.2	66.5	66.8	67.1	67.4	67.8	68.1	68.4	68.7	69	69.4	69.7	70	70.3	70.6	71	71.3	71.6	71.6
66.2	66.5	66.8	67.2	67.5	67.8	68.1	68.4	68.8	69.1	69.4	69.7	70	70.4	70.7	71	71.3	71.6	72	72.3	72.6	72.6
67.2	67.5	67.8	68.2	68.5	68.8	69.1	69.4	69.8	70.1	70.4	70.7	71	71.4	71.7	72	72.3	72.6	73	73.3	73.6	73.6
68.2	68.5	68.8	69.2	69.5	69.8	70.1	70.4	70.8	71.1	71.4	71.7	72	72.4	72.7	73	73.3	73.6	74	74.3	74.6	74.6
69.2	69.5	69.8	70.2	70.5	70.8	71.1	71.4	71.8	72.1	72.4	72.7	73	73.4	73.7	74	74.3	74.6	75	75.3	75.6	75.6
70.2	70.5	70.8	71.2	71.5	71.8	72.1	72.4	72.8	73.1	73.4	73.7	74	74.4	74.7	75	75.3	75.6	76	76.3	76.6	76.6
71.2	71.5	71.8	72.2	72.5	72.8	73.1	73.4	73.8	74.1	74.4	74.7	75	75.4	75.7	76	76.3	76.6	77	77.3	77.6	77.6
72.2	72.5	72.8	73.2	73.5	73.8	74.1	74.4	74.8	75.1	75.4	75.7	76	76.4	76.7	77	77.3	77.6	78	78.3	78.6	78.6
73.2	73.5	73.8	74.2	74.5	74.8	75.1	75.4	75.8	76.1	76.4	76.7	77	77.4	77.7	78	78.3	78.6	79	79.3	79.6	79.6
74.2	74.5	74.8	75.2	75.5	75.8	76.1	76.4	76.8	77.1	77.4	77.7	78	78.4	78.7	79	79.3	79.6	80	80.3	80.6	80.6
75.2	75.5	75.8	76.2	76.5	76.8	77.1	77.4	77.8	78.1	78.4	78.7	79	79.4	79.7	80	80.3	80.6	81	81.3	81.6	81.6

*Flashing-point in Degrees Fahrenheit.*



**TESTING-SCHEDULE OF INDIAN PETROLEUM ACT, 1899 (as modified up to 1st November 1903).****“ I.—NATURE OF THE TEST-APPARATUS.<sup>1</sup>**

“ The apparatus consists of the following parts :—

“ (1) The oil-cup.

“ (2) The cover with slide, test-lamp, and clockwork arrangement for opening and closing the holes in the cover and for dipping the test-flame.

“ (3) The water-bath or heating vessel.

“ (4) The tripod stand with jacket and spirit-lamp for heating the water-bath.

“ (5) The thermometer for indicating the temperature of the oil in the oil-cup.

“ (6) The thermometer for indicating the temperature of the water in the water-bath.

“ (7) The thermometer for indicating the temperature of the oil before it is poured into the oil-cup.

“ (8) The dropping bottle or *pipette* for replenishing the test-lamp; and

“ (9) A barometer standardised at the Meteorological office of the Province or at any other place appointed by the Local Government.

“ The oil-cup is a cylindrical flat-bottomed vessel made of gun-metal or brass, and tinned or silvered inside. A gauge is fixed to the inside of the cup to regulate the height to which it is to be filled with the sample under examination.

“ The cup is provided with a close-fitting overlapping cover, which carries the thermometer, the test-lamp, and the adjuncts thereto. The test-lamp is suspended upon two supports by means of trunnions, which allow it to be easily inclined to a particular angle and restored to its original position. The socket in the cover, which is to hold a round-bulb thermometer for indicating the temperature of the oil during the testing operation, is so adjusted that the bulb of the latter is always inserted in a definite position below the surface of the liquid.

“ The cover is provided with three holes, one in the centre and two smaller ones close to the sides. These are closed and opened by means of a pivoted slide. When the slide is moved so as to uncover the holes, the suspended lamp is caught by a projection fixed on the slide, and tilted in such a way as to bring the end of the spout just below the surface of the lid. As the slide moves back so as to cover the holes, the lamp returns to its original position. Upon the cover, in front of and in a line with the nozzle of the lamp, is fixed a white bead, the diameter of which represents the size of the test-flame to be used.

“ The water-bath or heating vessel is so constructed that, when the oil-cup is placed in position in it, an air-space or air-chamber intervenes between the two : consequently, in applying the test under ordinary circumstances, the heat is transmitted gradually to the oil from the hot water through the air-space. The water-bath is fitted with a socket for receiving a long-bulb thermometer, to indicate the temperature of the water. It is also provided with a funnel, an overflow pipe, and two handles.

“ The water-bath rests upon a tripod stand, which is fitted with a copper

<sup>1</sup> This is the Abel-Pensky apparatus hereafter described (see pp. 785, 786, 787).

cylinder or jacket, so that the bath is surrounded by an enclosed air-space, which retains and regulates the heat. One of the legs of the stand serves as a support for a spirit-lamp which is attached to it by a small swing bracket.

"The clockwork arrangement, by which, during the operation of testing, the slide is withdrawn, and the test-flame dipped into the cup and raised again as the slide is replaced, is provided with a ratchet key for setting it in action for each test, and with a trigger for starting it each time that the test-flame is applied.

## "II.—DIRECTIONS FOR DRAWING THE SAMPLE AND PREPARING IT FOR TESTING.

"1. **Drawing the Sample.**—In all cases the testing officer or some person duly authorised by him shall personally superintend the drawing of the sample from an original unopened tin or other vessel.

"An opening sufficiently large to admit of the oil being rapidly poured or siphoned from the tin or other vessel shall be made.

"Two bottles, each of the capacity of about forty fluid ounces, are to be filled with the oil. One of these, the contents of which is intended to be preserved for reference in case of need, is to be carefully corked, the cork being well-driven home, cut off level with the neck, and melted sealing-wax worked into it. The other bottle may be either stoppered or corked.

"2. **Preparing the Sample for Testing.**—About ten fluid ounces of the oil, sufficient for three tests, are transferred from the bottle into which the sample has been drawn to a pint-flask or bottle, which is to be immersed in water artificially cooled until a thermometer, introduced into the oil, indicates a temperature not exceeding 50° Fahrenheit.

## "III.—DIRECTIONS FOR PREPARING AND USING THE TEST APPARATUS.

"1. **Preparing the Water-Bath.**—The water-bath is filled by pouring water into the funnel until it begins to flow out at the overflow-pipe. The temperature of the water at the commencement of each test, as indicated by the long-bulb thermometer, is to be 130° Fahrenheit, and this is attained in the first instance by mixing hot and cold water, either in the bath or in a vessel from which the bath is filled, until the thermometer which is provided for testing the temperature of the water gives the proper indication; or the water is heated by means of the spirit-lamp (which is attached to the stand of the apparatus) until the required temperature is indicated.

"2. **Preparing the Test-Lamp.**—The test-lamp is fitted with a piece of cylindrical wick of such thickness that it fills the wick-holder, but may readily be moved to and fro for the purpose of adjusting the size of the flame. In the body of the lamp, upon the wick, which is coiled within it, is placed a small tuft of cotton wool, moistened with petroleum, any oil not absorbed by the wool being removed. When the lamp has been lighted the wick is adjusted by means of a pair of forceps until the flame is of the size of the bead fixed on the cover of the oil-cup; should a particular test occupy so long a time that the flame begins to get smaller, through the supply of oil in the lamp becoming exhausted, three or four drops of petroleum are allowed to fall upon the tuft of wool in the lamp from the dropping bottle or *pipette* provided for that purpose. This can be safely done without interrupting the test.

"3. **Filling the Oil-Cup.**—The oil-cup having been previously cooled, by placing it bottom downwards in water at a temperature not exceeding 50°

Fahrenheit, is to be rapidly wiped dry, placed on a level surface in a good light, and the oil to be tested is poured in very slowly, without splashing, until its surface is level with the point of the gauge which is fixed in the cup. The round-bulb thermometer is inserted into the lid of the cup, care being taken that the projecting rim of the collar touches the edge of the socket; the test-lamp, prepared as already described, is placed in position, and the cover is then put on to the cup and pressed down so that its edge rests on the rim of the cup.

“ 4. **Application of the Test.**—The water-bath, with its thermometer in position, is placed in some locality where it is not exposed to currents of air, and where the light is sufficiently subdued to admit of the size of the entire test-flame being compared with that of the bead on the cover. The cup is carefully lifted without shaking it, and placed in the bath, the test-lamp is lighted, and the clockwork wound up by turning the key. The thermometer in the oil-cup is now watched, and when the temperature has reached  $56^{\circ}$  Fahrenheit, the clockwork is set in motion by pressing the trigger.

“ If no flash takes place, the clockwork is at once rewound, and the trigger pressed at  $57^{\circ}$  Fahrenheit, and so on, at every degree of rise of temperature, until the flash occurs, or until a temperature of  $95^{\circ}$  Fahrenheit has been reached.

“ If the flash takes place at any temperature below  $77^{\circ}$  Fahrenheit, the temperature at which it occurs is to be recorded. Two fresh portions of the sample are then to be successively tested in a similar manner, and the results recorded. If no greater difference than  $2^{\circ}$  Fahrenheit exists between any two of the three recorded results, and if in no instance the flash has taken place within eight degrees of the temperature at which the testing is commenced, each result is to be corrected for atmospheric pressure as hereafter described, and the average of the three corrected results is the flashing-point of the sample. In the event of there being a greater difference than  $2^{\circ}$  Fahrenheit between any two of the results, while in no instance has the flash taken place within eight degrees of the temperature at which the testing was commenced, the series of tests is to be rejected, and a fresh series of three similarly obtained, and so on, until a sufficiently concordant series is furnished, when the results are to be corrected, and the average taken in the manner already described.

“ If, however, a flash has occurred at or below  $64^{\circ}$  when the test is applied in the manner above described, the next testing shall be commenced ten degrees lower than the temperature at which the flash had been previously obtained (that is to say, at  $54^{\circ}$  or thereunder), and this procedure shall be continued until the results of three consecutive tests do not show a greater difference than  $2^{\circ}$ , and until a flash has not occurred in any of the three tests within eight degrees of the temperature at which the testing is commenced: Provided always that, if at the commencement of the series of tests, a flash has occurred on the first application of the test-flame at  $56^{\circ}$ , and if a flash has also occurred on the first application of the flame in each of three successive tests in which, thereupon, the test-flame is first applied at  $46^{\circ}$  as above directed, the testing officer shall certify that the petroleum has a flashing-point below  $47^{\circ}$ , and the sample shall be reported dangerous.

“ If a temperature of  $76^{\circ}$  Fahrenheit has been reached without a flash occurring, the application of the test-flame is to be continued at every degree of rise of temperature until a temperature of  $95^{\circ}$  Fahrenheit has been reached. If no flash has occurred up to this point, and if the petroleum is declared to be imported subject to the provisions of the Act, the tests shall not be continued, and the testing officer shall certify that the petroleum has a flashing-point over  $95^{\circ}$  and is not dangerous. But, if the petroleum is oil ordinarily used for

lubricating purposes, and is declared to have its flashing-point at or above 200°, or is oil to which a notification of the Local Government exempting it from the operation of the Act will be applicable in the event of the flashing-point being found to be at or above 120°, the test shall be continued as follows:—The oil-cup is to be removed from the water-bath, and the temperature of the water in the water-bath is to be reduced to 95° Fahrenheit by pouring cold water into the funnel (the hot water escaping by the overflow-pipe). The air-chamber is then to be filled to a depth of 1½ inch with water at a temperature of about 95° Fahrenheit, the oil-cup is to be replaced in the water-bath, and the spirit-lamp attached to the water-bath is to be lighted and placed underneath. The test-flame is then to be again applied from 96° Fahrenheit, at every degree rise of temperature as indicated by the thermometer in the oil-cup until a flash takes place, or until a temperature of 200° Fahrenheit or 120° Fahrenheit, as the case may be, has been reached. If during this operation the test-flame appears to diminish in size, the lamp is to be replenished in the manner prescribed at 2 without interrupting the test.

“ If a flash occurs at any temperature between 76° and 200° Fahrenheit, the temperature at which it occurs, subject to correction for atmospheric pressure, is the flashing-point of the sample.

“ In repeating a test a fresh sample of oil must always be used, the tested sample being thrown away, and the cup must be wiped dry from any adhering oil and cooled, as already described, before receiving the fresh sample.

“ 5. **Correction for Atmospheric Pressure.**—As the flashing-point of an oil is influenced by changes in atmospheric pressure to an average extent of 1·6° Fahrenheit for every inch of the barometer, a correction of the observed flashing-point may become necessary. The height of the barometer must therefore be determined at the time of making the test for the flashing-point. The true height of the barometer for the purpose of the test shall be considered to be the height of the column of mercury measured at 32° Fahrenheit, which is supported by the air pressure at the time of the experiment; that is, the actual height of the barometer at the time of observation duly corrected for any error of the instrument and for its temperature if necessary. For the purpose of applying the correction to the flashing-point of the oil obtained by the test, a table (see p. 780) is appended to this schedule giving the flashing-points of oils ranging from 65° to 80° Fahrenheit under pressures ranging from 27 to 31 inches of mercury.

“ The table is used in the following manner:—

“ *Example.*—An oil has given a flashing-point of 71°, the barometer being at 28·6 inches; take the nearest number to 71° in the vertical column headed 28·6. This number is 70·8. Substitute for this the number in the same horizontal line in the column headed 30 (the normal height of the barometer). The substituted number, that is, the true flashing-point of the oil, is 73°.

“ 6.<sup>1</sup> **Application of the test to viscous fluids or preparations, such as solutions of indiarubber in mineral naphtha, or thick paint made with that material.**

“ About a teaspoonful of the substance to be tested is placed in the cup, and the cover fitted with a thermometer is put on.

“ The cup thus prepared for the test is then cooled down until the thermometer indicates a temperature of 50° Fahrenheit. This may be accomplished either by placing the prepared cup in a refrigerator, or by immersing it up to its projecting collar in water, which is maintained at a sufficiently low temperature until the result specified has been obtained.

<sup>1</sup> This paragraph was added by Notification No. 928 (J.), dated 28th June 1900. See *Gazette of India*, 1900, Part I, p. 403.

“The prepared cup thus cooled is then transferred to the water-bath, the temperature of which has previously been raised to 70° Fahrenheit. (The scale of the thermometer in the water-bath should range from 60° to 180° Fahrenheit.)

“The test is then applied as described in section 4 of this part. If no flash has taken place when the temperature in the cup has reached 75°, the test need not be continued.

“The temperature at which the flash occurs is the observed flashing-point of the substance, and, subject to correction for atmospheric pressure as prescribed in the Act, is the true flashing-point.

#### “IV.—DIRECTIONS FOR DETERMINING THE FLASHING-POINT OF PETROLEUM WHICH IS NOT FLUID AT ORDINARY TEMPERATURES.

“1. **Nature of the Test-Apparatus.**—The instrument employed is the Abel-Pensky petroleum testing apparatus, fitted with an additional thermometer to indicate the temperature of the oil in close proximity to the walls of the cup. This thermometer has a cylindrical bulb,  $\frac{7}{8}$  inch in length and  $\frac{3}{16}$  inch in diameter. It is scaled from 45° to 165° Fahrenheit, ten degrees on the scale occupying  $\frac{3}{8}$  inch. The thermometer is held vertically in a socket attached to the cover of the oil-cup in such a position that the bulb is  $\frac{1}{10}$  inch from the side of the cup.

“(The thermometer can be removed and the orifice which is provided for it closed by means of an indiarubber plug, if the apparatus is required for testing petroleum in the ordinary way.)

“2. **Directions for Preparing the Sample for Testing.**—About ten fluid ounces of the oil are placed in a pint-flask, the mouth of which is then closed with an indiarubber stopper and the sample is liquefied by placing the flask in a water-bath, the temperature of which is only raised sufficiently high to liquefy the oil.

“3. **Directions for Preparing and Using the Test-Apparatus.**—The water-bath and test-lamp are to be prepared in the manner prescribed in Part III of this Schedule. The oil-cup is to be filled with the liquefied oil, and the cover (into which both thermometers are to be previously inserted) placed on it, care being taken that the bulb of the additional thermometer is not brought into contact with the bracket-gauge fixed inside the cup. The oil-cup is then to be placed in a refrigerator, or plunged up to the projecting collar in water maintained at sufficiently low temperature, until both thermometers indicate the temperature at which the testing of petroleum is directed in Part III of this Schedule to be commenced. The oil-cup is then to be removed, wiped dry and placed in the water-bath, and the testing effected in the manner prescribed in Part III of this Schedule, the temperature indicated by the additional (vertical) thermometer alone being noted, and the average of three determinations, duly corrected for atmospheric pressure, being recorded as the flashing-point of the sample, provided that no greater difference than 4° Fahrenheit exists between any two of such results.”

**Use of the Abel Test in other Countries.**—The various countries where the Abel tester in its original and modified forms are in use, and the respective minimum flashing-points prescribed, are given under Legislation.

**The Abel-Pensky Instrument.**—In 1880 the subject of petroleum-testing was investigated in Germany on behalf of the Government, and the Abel instrument was selected as the best, but, as exception was taken to the personal

error considered to be liable to be introduced by the method of applying the test-flame, the modification devised by Pensky, of Berlin, was adopted. The modification consists in effecting the movement of the slide and application of the test-flame by a clockwork arrangement, which ensures uniformity. A section of the instrument—which in all other respects is practically identical with the ordinary Abel apparatus—and the details of the clockwork mechanism, are shown in figs. 227 and 228, which also give the dimensions in millimetres.

The slide, *S*, pivoted on the centre, *z*, is set in motion by the arm, *d*, moving

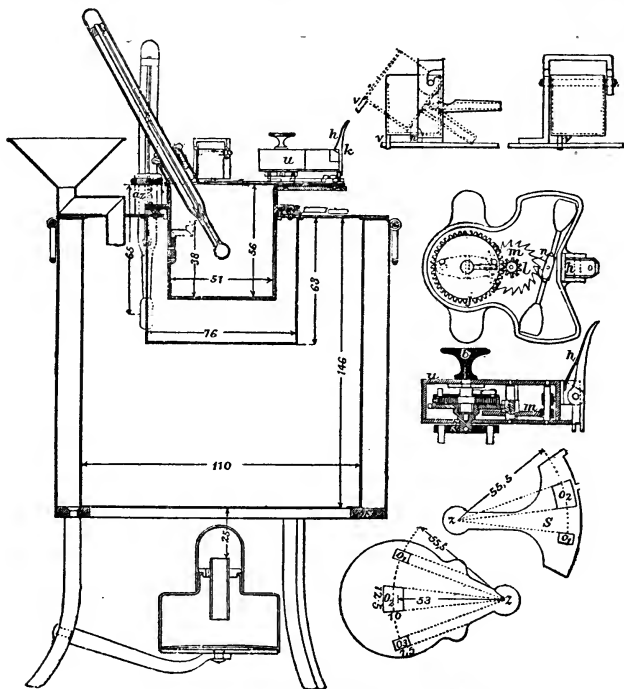

FIG. 227.—ABEL-PENSKY TESTING INSTRUMENT.

on a central axis. This arm carries on its under side two pins,  $e_1$ ,  $e_2$ . When the slide is in its normal position—*i.e.* closing the openings,  $o_1$ ,  $o_2$ ,  $o_3$ —one of the pins,  $e_1$ , rests against the steel plate, *f*, on the right-hand side of the slide, and the other,  $e_2$ , is held by the catch, *g*. On the axis of the arm, *d*, is fastened the spring-case, *u*, containing a spiral spring.

To wind up the clockwork, the knob, *b*, is turned half round, further winding being prevented by a stop. To move the slide, the trigger, *k*, is pushed towards the spring, *h*, the catch, *g*, being thus drawn back, and the pin,  $e_2$ , released. The spiral spring unwinds and presses the other pin,  $e_1$ , against the slide, moving this slide aside to the left, and uncovering the apertures. As soon as the pin

$e_1$  is carried by the revolution of the arm,  $d$ , past the steel plate,  $f$ , the slide is forced back to its former position by the spring,  $r$ , and the pin,  $e_1$ , is stopped by the catch,  $g$ , which returns it to its original place as the trigger,  $k$ , is released. These movements are repeated every time the test is applied. The uncoiling of the spiral spring and movement of the slide are regulated by the escapement,  $m n p$ . The three holes in the lid of the oil-cup, and the two holes in the

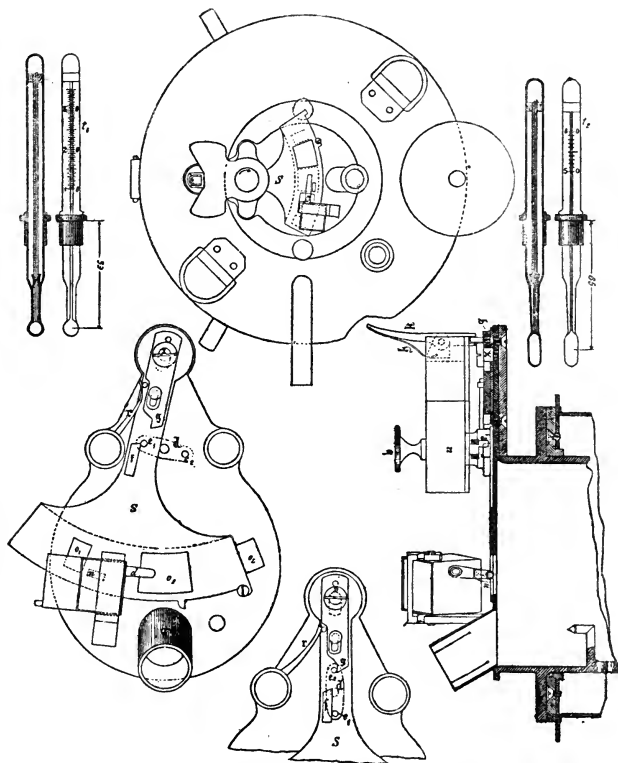

FIG. 228.—ABEL-PENSKY TESTING INSTRUMENT.

slide (the lateral movement of the slide uncovering and covering the third hole in the lid), are of the same dimensions as those in the Abel instrument, but not quite the same shape, on account of the circular motion of the slide. The lamp is tipped by a nosepiece,  $n$ , and on its return to the perpendicular, is prevented from swinging backwards by a stop,  $v$ .

**Directions for the Use of the Instrument.**—The following is the method of applying the Abel-Pensky test prescribed in Germany:—<sup>1</sup>

<sup>1</sup> *Vorschriften betreffend den Abelschen Petroleumprober und seine Anwendung*, Berlin, 1883.

The testing should be carried out in an apartment of medium temperature and free from draughts. The petroleum samples should be in closed vessels and have been long enough in the room to have acquired the same temperature, otherwise the tests will not be satisfactory.

The height of the barometer must be observed before commencing operations, and the temperature at which the test is to be first applied varies with the pressure indicated, according to the following table:—

TABLE CXXXVII.—INITIAL TEST-POINT FOR VARIOUS BAROMETRIC PRESSURES.

Height of Barometer.	First Test applied at
685 to 695 millimetres, . . . . .	+14° C.
695 to 705     " . . . . .	14°
705 to 715     " . . . . .	14.5°
715 to 725     " . . . . .	15°
725 to 735     " . . . . .	15.5°
735 to 745     " . . . . .	16°
745 to 755     " . . . . .	16.5°
755 to 765     " . . . . .	17°
765 to 775     " . . . . .	17°
775 to 785     " . . . . .	17.5°

If the barometer varies from the normal pressure of 760 mm. by more than  $2\frac{1}{2}$  mm. either way, the actual flashing-point observed is corrected in accordance with Table CXXXVIII. The table being arranged for intervals of 5 mm., intermediate pressures are counted as 0 or 5, according to the figure which they most nearly approach—viz. 742 counts as 740, 743 as 745, and so on. The instrument must be set level on the testing-table, with the aid of a spirit-level or plumb-line, before it is filled, and it should be at such a height that the red mark on the water-bath thermometer is on a level with the eye of the operator. The bath is next filled with water at +50° to 52° C. until a portion runs out through the overflow-pipe, to which an indiarubber tube should be attached to convey the surplus water away without splashing the apparatus or table. If cold water is used for filling the bath, it must be warmed by the heating lamp before putting in the oil-cup, care being taken that the base ring does not get overheated. The test-lamp is prepared for use by being packed with loose cotton wool, which is then saturated with petroleum, any surplus being poured out. If this is not attended to, the tipping of the lamp at the moment of applying the test might cause drops of oil to fall on to the lid of the tester and vitiate the results. The wick must also be cleansed from any adherent incrustation or char. The oil-cup, with its cover and thermometer, are to be thoroughly clean and dry, and all traces of oil from preceding tests are to be removed by drying and absorption. Finally, the petroleum to be tested, if not at least 2° cooler than the lowest of the temperatures recorded in the foregoing table, must be cooled down to that point, together with the oil-cup, the latter being dipped into cold water. To obtain very exact results, it is advisable to use water cooled to +11° C. for this purpose, and to keep the oil-cup in it long enough for proper cooling. Before inserting the oil-cup, the water-bath is heated up to 54° to 55° C., the temperature indicated by the red mark on the thermometer scale. Meanwhile, the oil is poured into the oil-cup by means of the pipette, until the extreme point of the indicator just projects above the surface of the liquid. It is important that this limit should not be exceeded, but if this should happen, the cup must be emptied, dried carefully, and refilled. Any bubbles forming on the surface of the oil must be dissipated by pricking with the warm charred point of a burned-out match. The table on



TABLE CXXXVIII.—CORRECTION OF APPARENT FLASHING-POINTS TO THE NORMAL BAROMETRIC PRESSURE OF 760 MILLIMETRES.

*Millimetre Pressure.*

685	690	695	700	705	710	715	720	725	730	735	740	745	750	755	760	765	770	775	780	785
-----	-----	-----	-----	-----	-----	-----	-----	-----	-----	-----	-----	-----	-----	-----	-----	-----	-----	-----	-----	-----

*Flashing-Points, Centigrade Scale.*

16.4	16.6	16.7	16.9	17.1	17.3	17.4	17.6	17.8	18.0	18.1	18.3	18.5	18.7	18.8	19.0	19.2	19.4	19.5	19.7	19.9
16.9	17.1	17.2	17.4	17.6	17.8	17.9	18.1	18.3	18.5	18.6	18.8	19.0	19.2	19.3	19.5	19.7	19.9	20.0	20.2	20.4
17.4	17.6	17.7	17.9	18.1	18.3	18.4	18.6	18.8	19.0	19.1	19.3	19.5	19.7	19.8	20.0	20.2	20.4	20.5	20.7	20.9
17.9	18.1	18.2	18.4	18.6	18.8	18.9	19.1	19.3	19.5	19.6	19.8	20.0	20.2	20.3	20.5	20.7	20.9	21.0	21.2	21.4
18.4	18.6	18.7	18.9	19.1	19.3	19.4	19.6	19.8	20.0	20.1	20.3	20.5	20.7	21.3	21.5	21.7	21.9	22.0	22.2	22.4
18.9	19.1	19.2	19.4	19.6	19.8	19.9	20.1	20.3	20.5	20.6	20.8	21.0	21.2	21.3	21.5	21.7	21.9	22.0	22.2	22.4
19.4	19.6	19.7	19.9	20.1	20.3	20.4	20.6	20.8	21.0	21.1	21.3	21.5	21.7	21.8	22.0	22.2	22.4	22.5	22.7	22.9
19.9	20.1	20.2	20.4	20.6	20.8	20.9	21.1	21.3	21.5	21.6	21.8	22.0	22.2	22.3	22.5	22.7	22.9	23.0	23.2	23.4
20.4	20.6	20.7	20.9	21.1	21.3	21.4	21.6	21.8	22.0	22.1	22.3	22.5	22.7	22.8	23.0	23.2	23.4	23.5	23.7	23.9
20.9	21.1	21.2	21.4	21.6	21.8	21.9	22.1	22.3	22.5	22.6	22.8	23.0	23.2	23.3	23.5	23.7	23.9	24.0	24.2	24.4
21.4	21.6	21.7	21.9	22.1	22.3	22.4	22.6	22.8	23.0	23.1	23.3	23.5	23.7	23.8	24.0	24.2	24.4	24.5	24.7	24.9
21.9	22.1	22.2	22.4	22.6	22.8	22.9	23.1	23.3	23.5	23.6	23.8	24.0	24.2	24.3	24.5	24.7	24.9	25.0	25.2	25.4
22.4	22.6	22.7	22.9	23.1	23.3	23.4	23.6	23.8	24.0	24.1	24.3	24.5	24.7	24.8	25.0	25.2	25.4	25.5	25.7	25.9

which the cup stands during the operation of filling should be perfectly horizontal and quite near to the water-bath, to minimise the risk of tilting or shaking the cup. The oil is poured into the centre of the cup, and not against the sides, and to prevent bubbles, the nozzle of the pipette should be kept below the surface of the liquid. The utmost exactness is obtained by slowly adding the oil by a pipette until the point of the indicator is just *about* to disappear under the surface of the liquid, and then removing the excess by the insertion of a small pipette. Bubbles formed by emptying the cup may be removed on refilling by a warm metallic point or a charred match. The lid of the cup is put on directly after pouring in the oil, the thermometer being previously inserted in its socket, and pressed down tightly, avoiding contact between the ebonite plate under the clockwork and the knobs, K, on the bath, as this would prevent the lid from fitting properly. The insertion of the oil-cup into the bath must be done without tilting or shaking, and to avoid the risk of this, the cup, previously cooled by ice and water to  $8^{\circ}$  C. (to prevent the oil getting warm while filling), may be put into position before filling. Should the water-bath be at a higher temperature than  $54^{\circ}$  to  $55^{\circ}$  C., it must be cooled by the addition of cold water, and when that degree is reached, the lamp is extinguished.

When the oil approaches the temperature at which the first test is to be applied, in accordance with the foregoing table, the test-lamp is lighted and the flame adjusted until, when viewed from the front, it is of the same width as the white bead on the lid. This is important, as the size of the flame has an influence on the flashing temperature. The clockwork is then wound up by turning the milled head as far as it will go in the direction indicated by the arrow. On releasing the catch by pressing on the trigger, the slide slowly and regularly moves aside, and at the end of two seconds has returned to its original position. During the movement of the slide, the behaviour of the test-flame as it approaches the surface of the oil must be carefully observed, particular attention being directed to sheltering the apparatus from all draughts and from the breath of the operator. This is facilitated by the provision of a glass plate fixed to the draw-out side of the case containing the apparatus. The test is to be repeated at every  $\frac{1}{2}^{\circ}$  rise of the thermometer until a flash is obtained. Before the absolute flashing-point is reached, the size of the test-flame will be observed to increase by a kind of halo when dipped towards the oil, but the true flash is a bluish lightning-like flame extending over the whole free surface of the oil. The temperature indicated by the thermometer is subject to correction, both as regards barometric pressure and error, if any, of the thermometer itself, according to the variation ascertained on standardising the instrument. The test is repeated with a fresh portion of the same oil, after cooling the oil-cup and lid, drying and freeing them, as well as the thermometer, from all adherent drops of oil, and reheating the bath to  $55^{\circ}$  C.

If the result of the second test agrees with the first within  $\frac{1}{2}^{\circ}$ , the average is taken as the apparent flashing-point. If, however, the difference is  $1^{\circ}$  or more, a third test is necessary; and provided the results of the three do not differ more than  $1\frac{1}{2}^{\circ}$ , the average is taken. In case of a greater divergence, a fresh set of tests must be made. In the case of oils flashing at the first application of the test-flame the actual flashing-point may be higher than is indicated by the thermometer, the accumulation of vapour in the oil-cup causing the flash to occur sooner than it would under ordinary circumstances. If it is desired to test such oils accurately, the operation is begun at a lower temperature than usual, and repeated at lower degrees until no flash is produced on first opening the slide.

The apparent flashing-points must be corrected for pressure, according to Table CXXXVIII, by finding the observed flashing-point in the column headed by the existing height of the barometer, and proceeding in the same row to the column headed 760, which will show the actual flashing-point at normal pressure. Fractions between the figures given in the table are to be counted as the figure to which they most nearly approach. Any error recorded by the standardiser of the apparatus must be corrected before applying the correction in the table.

**The Standardising of the Abel-Pensky Instrument.**—By an order of the Imperial Chancellor, dated 21st July 1882, the Kaiserliche Normal-Aichungs-Kommission was empowered to standardise and stamp instruments for testing petroleum, particular attention being devoted to the following points:—

- (a) The dimensions of the apparatus.
- (b) The accurate timing of the slide movement.
- (c) The accuracy of the thermometer.
- (d) The correctness of the flashing-points indicated by the apparatus.
- (e) The accuracy of the metallic barometer supplied with the instrument.

The examination of the thermometers should not take place until they have been delivered.

In verifying the dimensions of the apparatus, the following variations from the exact standard are allowed in:—

	Millimetres.
The thickness of the metal plates, . . . . .	0.2
The diameter of the lamp-spout, . . . . .	0.2
The distance of the point of the filling-indicator from the upper edge of the cup, . . . . .	0.5
The distance from the lower corner of the inside of the lamp-spout to the upper face of the cup-lid when the lamp is fully tipped, . . . . .	0.5
The thickness of the ebonite ring, . . . . .	0.5
The inside diameter and height of the oil-cup; the width of the brass ring; its distance from the upper edge of the cup; the distance of the axis of the slide from the centre of the cup-lid and the centre of the three apertures; the diameter of the bead; and the dimensions of the tube for the insertion of the thermometer, $t_1$ , . . . . .	1.0
The distance of the centre of the bulb of the thermometer, $t_1$ , from the end of the sheathing tube and from the underside of the cup-lid, . . . . .	1.0
The dimensions of the water-bath, and of the outer cylinder; the width of the ebonite ring on the bath; and the distance of the lowest mark on the scale of either thermometer from the enlargement on the tube, . . . . .	2.0

The variation of time allowed for the slide movement is 0.2 second over or under the prescribed standard. The thermometer,  $t_1$ , may not vary from the normal instrument more than 0.2° C. when tested in four places on the scale, and the thermometer,  $t_2$ , not more than 0.5° C. when tested in two places. Furthermore, successive portions of the same sample of oil, consecutively examined, should not show a greater divergence of flashing-point than 0.75° C., and the average of five or seven such tests should not differ from the average of the same recorded by the standard by more than 0.5° C., an oil approximating to the standard flashing-point being used for the experiment. The metallic barometer belonging to the apparatus should not differ more than 2 millimetres from the standard at the ordinary room temperature. It must be examined with a view to ascertaining the influence of sudden alterations of pressure or continued shaking of the instrument on its accuracy between the limits of 680 and 790 mm. The instruments which satisfy the tests imposed are stamped by the Normal-Aichungs-Kommission on all the removable portions, and the

amount of variation or error of flashing-point to be allowed for is indicated. The maker's name, the number of the instrument, and the year of examination are included in the stamping, and all the particulars are inscribed on a certificate issued by the standardiser, together with the following measurements:—

- (a) Distance of the point of the filling-indicator from the upper edge of the oil-cup.
- (b) Distance of the lowest inside point of the lamp-spout from the under surface of the cup-lid when the lamp is fully tilted.
- (c) Distance of the central point of the oil-thermometer bulb from the under surface of the cup-lid.

To guard against any alteration on these points subsequent to standardising, the Normal-Aichungs-Kommission send out with each apparatus examined, a stamped gauge consisting of a rectangular steel plate, on one side of which is a projection for controlling the measurement, *a*; on the other a second projection bounded by two flutings, to measure, *b*, and furnished with a projecting stud on one of its flat surfaces for gauging, *c*. To examine *a*, the gauge is applied to the edge of the oil-cup so that the projection hangs down inside and the mark on it is touched by the point of the filling-mark. For the second verification, *b*, the clockwork is set in motion, and the apertures in the lid are wedged open so that the mouth of the lamp is at its lowest point. The gauge is then applied under the lid, and the lower inside corner of the spout should coincide with the end of the smaller projection. For examining *c*, the side of the gauge opposite to the smaller projection used for *b* is applied to the under side of the lid, when the stud should exactly touch the middle of the bulb of the thermometer. The length of the lamp-spout can also be verified, a mark cut at right angles to the plain side of the gauge showing the exact size. The edge of the spout-mouth should coincide with the mark; and should either the top or bottom corner fail to do so, the apparatus is out of adjustment.

In 1907, an International Commission for the Unification of the Methods of Testing Petroleum Products<sup>1</sup> was appointed, with Dr. Leo Ubbelohde, of the Technical High School, Karlsruhe, Baden, as General Secretary. It had long been known that the German Abel-Pensky instrument gave results at least 3° F. lower than those furnished by the English Abel apparatus, and the Commission commenced its labours by undertaking the examination and comparison of various methods of determining the flash-point of petroleum. At the invitation of the English section of the Commission, the National Physical Laboratory undertook to assist in the investigation, and the results reached in the first stage of this work have been given in a report by Dr. J. A. Harker, F.R.S., Senior Assistant in the Physics Department, and Mr. W. F. Higgins, Junior Assistant in the Physics Department. The report, which was issued during 1911, gives full details of the experimental investigation carried out, and is divided under the following heads:—On the apparatus and methods used in petroleum testing; Thermometry; Accuracy attainable in flash-point determinations; The general theory of flash-point determination; Temperature distribution; The heating effect of the test-flame; Comparisons of the flash-points obtained on different types of apparatus; Summary and general results of the investigation; Appendix, Section 1, flash-points of mixtures of oils; Appendix, Section 2, notes to the table of dimensions; Appendix, Section 3, the "lag" of the different types of thermometers employed. The instruments employed were the English Abel apparatus, the British-Colonial type of Abel-Pensky apparatus, and the German Abel-Pensky

<sup>1</sup> Now called the International Petroleum Commission.

apparatus. The average values of the differences between the flash-point as obtained in the Abel apparatus and on the other types were found to be:—

Colonial type of Abel-Pensky, 1.1° F. higher.

German type of Abel-Pensky, 3.7° F. higher.

The details of the experiments made afford an explanation of the causes of these differences, as is indicated in the following summary:—

The main result of the investigation thus far has been to ascertain what is almost certainly the true cause of the differences in the flash-points given by specimens of the same type of apparatus and by those of different types. The results may be summarised as follows:—

1. The influence of variations in the method of procedure in making a test has been studied; the points investigated include the effect of:

(a) The frequency of application of the test-flame.

(b) Variations in the time of opening of the slide.

(c) Variations in the water-bath temperature.

(d) Variations in the depth of immersion of the thermometer.

2. The temperature distribution in the oil-cup was investigated and it was found that large systematic differences of temperature between different parts of the apparatus were always present; also that the temperature distribution was not the same in the different types of apparatus. This has been investigated in full for the Abel and Colonial type of Abel-Pensky apparatus; and also to some extent in the case of the German Abel-Pensky. The differences found between the three forms of apparatus are satisfactorily and completely explained by the results of these experiments on temperature distribution.

3. It was found that the heat from the test-flame was a factor of considerable importance in the carrying out of a flash-point test, and that, owing to the difficulty of always setting the flame to the same size, differences of  $\pm \frac{1}{2}$ ° F. are to be expected even in the most careful work, more especially in the apparatus provided with the oil test-flame.

4. The difference between the flash-points obtained with the different types of tester has been investigated and has been found to be approximately constant at all temperatures. It might be noted here that a difference has been found to exist between the results obtained with the two forms of Abel apparatus, fitted with oil and gas test-flames respectively; the latter reads lower by about  $\frac{1}{2}$ ° F. Further systematic comparisons between all the different types of apparatus are contemplated.

5. It must be recognised that the flash-point of a liquid, as ordinarily determined, is an empirical constant, which is largely a function of the particular apparatus used. It would seem desirable, therefore, to establish, if possible, a more definite connection between this property and the real physical properties of the substance. Experiments are now in progress to study the relation subsisting between "flash-point" and vapour pressure, both with oils and other substances, and it is hoped that out of these experiments it may be possible to establish conditions under which certain definite liquids may be used for the standardisation of different forms of flash-point apparatus.

**Braun's Modification.**—In 1882 Braun of Berlin patented the application of a magnetic pendulum arrangement for applying the test-flame in the Abel apparatus.

**The Use of a Stirrer in the Oil-Cup.**—In 1881 Engler and Haass made a number of experiments with the Abel and other instruments, and came to the conclusion that the provision of a stirrer in the oil-cup was desirable. Victor Meyer had previously expressed the same opinion. In the Abel apparatus, a stratum of vapour is formed upon the surface of the oil, and the temperature of

the oil is not uniform throughout. It is, therefore, necessary that the dimensions of the air-space above the oil, the depth to which the test-flame is inserted, the size of the orifices in the cover, the position of the thermometer bulb, and other particulars should be defined with greater accuracy than would probably be necessary if a stirrer were added; but experience has shown that the Abel instrument can be readily standardised, and any number of instruments can thus be constructed to give concordant results if used with a reasonable amount of care. The addition of a stirrer is no doubt desirable when the Abel instrument in its original or modified form is applied to the testing of oils of high flashing-point, such as lubricating oils, and its use is necessary in the testing of liquids such as paints containing solid materials in suspension, as these interfere with the formation of convection currents; but Dr. Engler and Dr. Bunte have expressed to the author their concurrence in his view that it is not requisite when the instrument is employed in testing kerosene.

**Letheby's Electric Tester.**—In addition to the Saybolt electric tester, several others in which ignition of the oil-vapour is produced by an electric spark are and have been in use. As early as 1870 the author saw a closed tester with an electric-spark igniting-arrangement in use by the late Dr. Letheby in the laboratory of the London Hospital. The oil-cup was of glass, and had a hinged metal cover which was blown open on ignition of the vapour.

**Pease's Electric Tester.**—In Pease's closed tester (fig. 229) the vapour is ignited by an electric spark passing between wires, C, above the oil in the cup, B, which rests in a water-bath, A.

**Engler's Electric Tester.**—In Dr. Engler's closed-cup electric tester<sup>1</sup> (figs. 230 and 231) the copper water-bath, A, which is heated by a lamp, B, is 15 centimetres in diameter at the top, 18 at the bottom, and 15 centimetres high, including the feet. It carries a perforated plate, 4 centimetres from the top, supporting a cylindrical glass water-bath, C, 10 centimetres wide and 12 to 14 centimetres high. The bath, C, which has a mark to indicate the proper height of the water, and is provided with a lid, *m*, and a thermometer, *n*, contains the glass oil-cup, D, 10 centimetres high and 5½ centimetres in internal diameter. The oil-cup has a lid, *o* (fig. 231), which is not fixed very tightly, in order that it may be blown off without injuring the apparatus in case of an unusually strong explosion. It has a stirrer, *p*, with a handle, *q*, and a thermometer, *r*, and is further fitted with two wires, *t*, *t*, connected with an induction-coil and terminating, inside the cup, in platinum points 1 millimetre apart and from ½ to ⅔ centimetre above the surface of the oil. Ebonite insulators, *u*, prevent short-circuiting through the lid, *o*. A chromate battery and small induction-coil capable of producing sparks from 2 to 3 millimetres in length are used. Hinged flaps, *s*, cover openings in the lid, *o*.

**Directions for Use.**—In testing an oil, the water-baths are filled with water, and the oil-cup, to a mark, with the oil. When the oil-cup is in place, the water in the bath, C, reaches to within 1 centimetre of the top. The spirit-lamp being lighted, the temperature of the oil gradually rises, a rapid increase of temperature being prevented by the use of the two water-baths, so that the size of the heating flame makes little difference in the rate of progression. The difference between the water and oil thermometers should not exceed 5° C. At about 20° C. the spark is passed, during ½ to 1 second, and this is repeated at each rise of 1° until the flashing-point is reached, when the explosion produced blows open the hinged flaps, *s*, *s*. A few precautions are necessary to ensure accuracy. Between the applications of the spark, the stirrer should be rotated a few times, but very carefully in order to avoid splashing the platinum

<sup>1</sup> *Zeitschr. anal. Chemie*, xx, 27 (1881), and *Post's Chemisch-technische Analyse*, ii, 299 (1888).

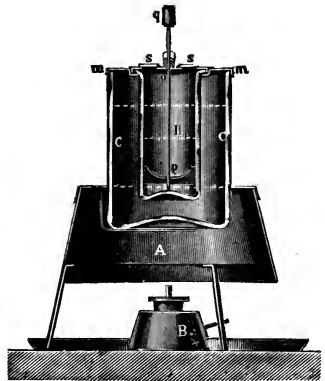
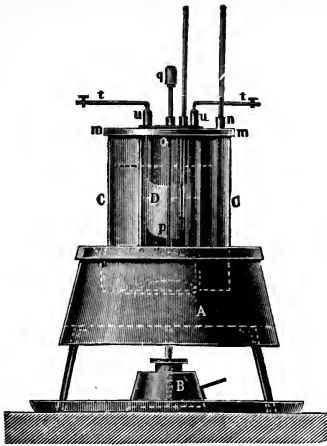

FIG. 230.—ENGLER'S ELECTRIC TESTER.

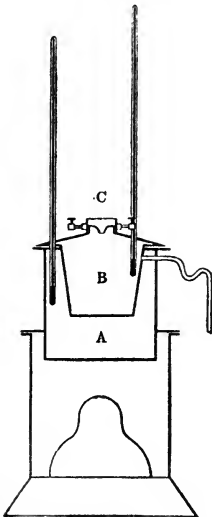

FIG. 229.—  
PEASE'S ELECTRIC TESTER.

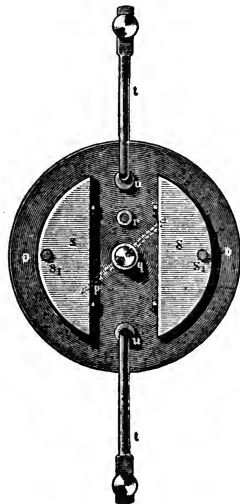

FIG. 231.—  
ENGLER'S ELECTRIC TESTER (CUP-LID).

electrodes. When the apparatus is used several times in succession, fresh water must be poured into the upper water-bath, refilling of the lower bath being unnecessary, as not affecting the results. If a difficulty is experienced in getting the spark to pass freely, this is generally found to be due to one of two causes. Either the apparatus has been brought from a cold to a warm room, and a deposit of moisture has occurred on the electrodes, which can be removed by standing the instrument in a warm place for a short time; or the points have become dirty from constant use, in which case they must be cleaned with sand-paper or a file. The current should be strong enough to give a good spark when the points are 1 millimetre apart, but not so powerful as to short-circuit through the metallic lid of the apparatus.

**Heumann's Modification.**—In a modification of the Engler instrument introduced by Heumann, the stirrer acts upon the vapour in the oil-cup as well as upon the oil,<sup>1</sup> and a gas-flame is substituted for the electric spark. The following is a description of the apparatus:—In fig. 232, *a* is a glass oil-cup, with a base, *g*, forming a support for the stirrer; *b*, the metal water-bath; *c*, the stirrer; *t*, the thermometer; and *d*, the test-flame. This flame is supplied with gas at *k*, through an upright tube, *i*, and can be brought into contact with the oil-vapour by depressing the tube. On being released, the tube is returned to its former position by the action of a spring, *f*. The cup-lid is fitted with hinged flaps, as in the Engler instrument. The test-flame is applied at each degree until the lid-flaps are thrown open by the flash. Results agreeing within  $\frac{1}{2}^{\circ}$  C. are said to be obtained.

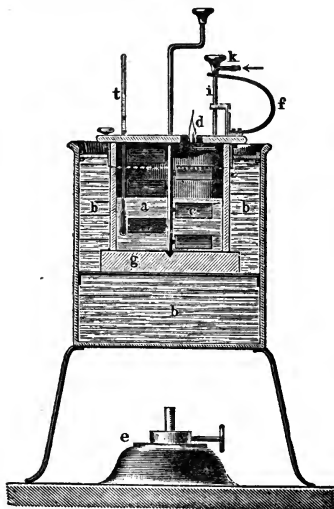

FIG. 232.—HEUMANN TESTER.

a water-bath. When the expected flashing-point is approached—the temperature being indicated by a thermometer passed through the cork—the cylinder is removed, quickly shaken, allowed to stand until the froth has broken, then opened, and a small gas-flame applied to the mouth. If the mixture of air and oil-vapour explodes, the experiment is repeated at lower temperatures, with  $1^{\circ}$  C. difference between the tests. If no explosion occurs, the experiment is similarly repeated at higher temperatures.

**Haass's Modification.**—An improvement on Victor Meyer's method, introduced by Haass, has been described.<sup>2</sup> The oil-cup is a vertical glass cylinder with a hinged copper lid. A knob fixed in the lid is traversed by a capillary channel, to relieve the internal pressure. Two platinum wires passing through the sides of the cup, and separated at the terminals by a distance of 1 milli-

<sup>1</sup> *Die chemische Industrie*, vii, 188 (1884), and Post's *Chemisch-technische Analyse*, ii, 301 (1888).

<sup>2</sup> *Zeitschr. anal. Chemie*, xx, 29 (1880).



metre, are connected, outside the cup, with two copper wires passing to metal plates on opposite sides of the bottom of the cup. To ensure a constant temperature, the oil-cup is enclosed in an outer cylinder resting on the base of the oil-cup, and fastened above by catches in a sliding ring. The heat is applied by an air-bath having an earthenware cover, and fitted with a rack-work arrangement for raising and lowering the oil-cup to vary the temperature. A chromate battery is used, and the arrangements are such that connection is made by placing the oil-cup with its bottom plates on a pair of terminals.

**Directions for Use.**—The oil-cup is filled up to the mark with the oil to be tested, and, enclosed in its jacket, is placed in the previously warmed air-bath. The temperature is then caused to rise gradually, by adjusting the lamp and the depth of immersion of the oil-cup in the air-bath, so that the difference between the air and oil-thermometers is only  $5^{\circ}\text{C}$ . at most. When the requisite temperature is attained, the oil-cup, with its jacket, is removed, shaken about ten times (closing the hole in the knob with the finger), and placed on the terminals, the temperature being noted. After waiting for the bubbles to subside, and another minute for the spray to settle, contact is made, and the spark passed during one second. The process is repeated until the lid is thrown open by the occurrence of an explosion. Experiments show that variations in the rate of heating, the strength of the current, and the length and duration of the spark, only affect the results when carried to extremes. The size of the instrument, the quantity of oil, and the distance of the platinum points from the surface of the oil, are also without effect on the results.

The Abel instrument was by no means the first close-test apparatus devised, but it has been convenient to consider both it and certain other forms in describing the development of petroleum legislation in this country and on the Continent.

**Tagliabue's Closed Tester.**—As early as 1862 Tagliabue patented in America a "coal-oil pyrometer," for use either as a closed cup to determine the flashing-point, or as an open cup for ascertaining the igniting-point of the oil. The apparatus is shown in figs. 233 and 234, the upper portion of fig. 234 showing the cover of the instrument illustrated in fig. 233, while the larger illustration in fig. 234 shows a simpler form of the apparatus. The cylindrical water-bath is supported by a metal stand having an aperture near the bottom for the introduction of a small spirit-lamp. The vapour disengaged from the oil by the application of heat, mixes with atmospheric air admitted through perforations in the lid, and an explosive mixture is thus formed, which ascends into the dome. The flashing-point of the oil is ascertained by the insertion of a lighted taper or match into an opening in the dome, at intervals until a slight explosion occurs. To determine the igniting-point of the oil, the cup is opened by partially revolving the cover, and the test-flame is held for one or two seconds in contact with the escaping vapour.

**Directions for Use.**—Remove the cover, *a*, of the instrument by turning it



FIG. 233.

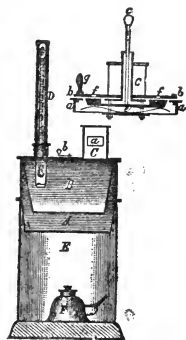

FIG. 234.

TAGLIABUE'S CLOSED TESTER.

until the vertical slots come into position to allow of its being taken off, take out the oil-cup, fill the outer vessel with water to a distance of within 2 inches from the top, replace the oil-cup and fill it with the oil to be tested to within  $\frac{3}{8}$  inch from the top, replace and secure the cover in position, supply the lamp with alcohol and trim the wick to give a small flame, light it and place it under the water-bath. The mercury in the thermometer will soon begin to rise; watch this carefully until it approaches to within about 20° F. of the temperature at which the oil is expected to flash, remove the lamp, press down the brass knob, *c*,<sup>1</sup> which will open the valves, and allow air to enter into the instrument, and vapour to rise in the dome, *C*. Into the aperture of this insert a very small lighted taper, and if the vaporising-point has been reached, a slight "puff" will occur; if this should not take place, replace the lamp and allow the mercury in the thermometer to ascend very slowly, 2° or 3° F. per minute; remove the lamp and perform the same operation with the lighted taper until the slight "puff" is produced; proceed very slowly with this operation, and when the "puff" occurs, take a simultaneous reading of the thermometer; this indicates the flashing-point. To ascertain the burning-point of the oil, replace the lighted lamp and allow the thermometer to rise about 8° F.; now remove the lamp, swing back the cover by means of the handle, *g*, and pass the lighted taper quickly across the oil without inclining the taper downwards; if the burning-point has been attained, the oil will ignite; if not, cover the oil and replace the lamp, watching the thermometer carefully, and not allowing the mercury to rise more than 3° or 5° F. between the tests. When the oil takes fire, read the thermometer, and this will give the igniting-point. It is advisable in all cases to make more than one test of the oil; in each new test the water and oil should be changed, and the instrument allowed to cool. Having learned the vaporising-point in the first operation, in the succeeding ones the instrument can be more carefully watched, and probably the flashing-point recorded will be lower than in the first operation. When "high grade" oils are being tested, sand is placed in the outer vessel instead of water. The author has not found it possible to obtain concordant results with this instrument. In some cases the results closely agree with those furnished by the Abel apparatus, but in most instances they appear to be from 6° to 8° F. higher, and occasionally 10° or 12° higher. This apparatus was formerly used in Germany.<sup>2</sup> The simpler form of the instrument shown in fig. 234 consists of a water-bath, *A*; an oil-cup, *B*; the hood, *C*, with an opening, *a*, into which the test-flame is inserted; the thermometer, *D*; the body, *E*; the lamp, *F*; and the pivoted cover, *b*, over the air-inlet.

**Wisconsin Tester.**—The instrument officially employed in the State of Wisconsin has a copper oil-cup with a copper cover in which there is a small opening for the insertion of the test-flame.

**Elliott Tester.**—In 1882 the State Board of Health of New York adopted a form of the tester last described, embodying improvements suggested by Professor Arthur H. Elliott, the chief of which was the substitution of a glass for a metal cover. The following is the official description of the apparatus and of the mode of applying the test:—

"The instrument consists of a sheet-copper stand  $8\frac{1}{2}$  inches high, exclusive of the base, and  $4\frac{1}{2}$  inches in diameter. On one side is an aperture  $3\frac{1}{2}$  inches high, for introducing a small spirit-lamp about 3 inches in height, or better,

<sup>1</sup> This knob is connected with a bar, *e*, the ends of which normally cover apertures, *f*, in a pivoted plate, *b*. The plate may be moved by means of a handle, *g*, when it is desired to open the cup. The bar, *e*, is supported by a spring.

<sup>2</sup> *Zeitschr. anal. Chemie*, xxi, 15 (1881).

a small gas-burner in place of the lamp, when a supply of gas is at hand. The water-bath is also of copper, and is  $4\frac{1}{2}$  inches in height and 4 inches inside diameter. The opening in the top is  $2\frac{1}{2}$  inches in diameter. It is also provided with a  $\frac{1}{4}$ -inch flange which supports the bath in the cylindrical stand. The capacity of the bath is about 20 fluid ounces, this quantity being indicated by a mark on the inside. The lower portion of the copper oil-holder is  $3\frac{3}{8}$  inches high and  $2\frac{3}{8}$  inches inside diameter. The upper part is 1 inch high and  $3\frac{3}{8}$  inches diameter, and serves as a vapour-chamber. The upper rim is provided with a small flange which serves to hold the glass cover in place. The oil-holder contains about 10 fluid ounces when filled to within  $\frac{1}{8}$  of an inch of the flange which joins the oil-cup and the vapour-chamber. In order to prevent reflection from the otherwise bright surface of the metal, the oil-cup is blackened on the inside by forming sulphide of copper by means of sulphide of ammonium. The cover is of glass, and is  $3\frac{5}{8}$  inches in diameter; on one side is a circular opening, closed by a cork through which the thermometer passes. In front of this is a second opening  $\frac{3}{4}$  of an inch deep and the same in width on the rim, through which the flashing-jet is passed in testing. The substitution of a glass for a metal cover more readily enables the operator to note the exact point at which the flash occurs. A small gas jet,  $\frac{1}{4}$  inch in length, furnishes the best means for igniting the vapour. Where gas cannot be had, the flame from a small waxed twine answers very well. The test shall be applied according to the following directions:—

“ Remove the oil-cup and fill the water-bath with cold water up to the mark on the inside. Replace the oil-cup and pour in enough oil to fill it to within  $\frac{1}{8}$  of an inch of the flange joining the cup and the vapour-chamber above. Care must be taken that the oil does not flow over the flange. Remove all air bubbles with a piece of dry paper. Place the glass cover on the oil-cup, and so adjust the thermometer that its bulb shall be just covered by the oil. If an alcohol lamp is employed for heating the water-bath, the wick should be carefully trimmed and adjusted to a small flame. A small Bunsen burner may be used in place of the lamp. The rate of heating should be about  $2^{\circ}$  per minute, and should in no case exceed  $3^{\circ}$ . As a flash-torch, a small gas-jet  $\frac{1}{4}$  inch in length should be employed. When gas is not at hand, employ a piece of waxed linen twine. The flame in this case, however, should be small. When the temperature of the oil has reached  $85^{\circ}$  F., the testings should commence. To this end, insert the torch into the opening in the cover, passing it at such an angle as well to clear the cover, and to a distance about half-way between the oil and the cover. The motion should be steady and uniform, rapid and without any pause. This should be repeated at every  $2^{\circ}$  rise of the thermometer until the temperature has reached  $95^{\circ}$ , when the lamp should be removed, and the testings should be made for each degree of temperature until  $100^{\circ}$  is reached. After this, the lamp may be replaced if necessary, and the testings continued for each  $2^{\circ}$ . The appearance of a slight bluish flame shows that the flashing-point has been reached. In every case, note the temperature of the oil before introducing the torch. The flame of the torch must not come in contact with the oil. The water-bath should be filled with cold water for each separate test, and the oil from a previous test carefully wiped from the oil-cup. The instrument to be used in ascertaining the igniting-point of oils shall consist of the cylinder, the copper oil-cup, together with a copper collar for suspending the cup in the cylinder, and an adjustable support for holding the thermometer. The test for ascertaining the igniting-point shall be conducted as follows:—Fill the cup with the oil to be tested to within  $\frac{3}{8}$  of an inch of the flange joining the cup and the vapour-chamber above. Care must be taken that the oil does not flow

over the flange. Place the cup in the cylinder and adjust the thermometer so that its bulb shall be just covered by the oil. Place the lamp or gas-burner under the oil-cup. The rate of heating should not exceed  $10^{\circ}$  a minute below  $250^{\circ}$  F., nor exceed  $5^{\circ}$  a minute above this point. The testing-flame described in the directions for ascertaining the flashing-point should be used. It should be applied to the surface of the oil at every  $5^{\circ}$  rise in the thermometer till the oil ignites."

An inconveniently large quantity of oil is required for this test, and, according to the author's experience, the results obtained, while not differing greatly from those furnished by the Abel instrument, are less concordant.

**Granier's Tester.**—The first "automatic" tester introduced was that of Granier, which has for many years been officially employed in France, and is thus described.<sup>1</sup> The apparatus consists of a small copper cup divided into two concentric parts, the walls of the inner division being conical. In the aperture at the apex of the cone is inserted a tubular wick on a small mandrel which stands in a depression formed in the bottom of the cup, so as to be perfectly upright. There is a small tube in the outer division to serve as a gauge for the quantity of oil, and as an overflow-pipe to carry away any slight excess. Heat is applied to the oil, not by a lamp below, but by means of a bent copper wire fixed in the aperture of the lid, so as to receive heat from the test-flame and convey it to the oil, into which its two ends dip. The cover has a circular opening over the test-flame, with a small lid also pierced by a central aperture.

**Directions for Use.**—The method of applying the test as prescribed by law is as follows:—The apparatus must be clean, and the wick must be renewed if carbonised to a depth exceeding 1 mm. The wick, fixed upon its metallic mandrel, is placed in the metallic cone in the cup, so as to rest evenly on the bottom of the cup. The oil to be tested, the temperature of which should not exceed  $25^{\circ}$  C., is poured into the cup in such a manner that it runs into the wick, the cup being filled to the top of the connecting tube. The cover is then placed on the cup, the small lid in the centre of the cover closed, and the thermometer placed in its socket. To ascertain the degree of inflammability, a lighted match is held near the small orifice in the centre of the small lid, and kept there for several seconds, and the temperature at which a petroleum-vapour flame appears and remains above the orifice is carefully noted. If a persistent vapour flame is not obtained, the wick should be lighted at several points, so as to produce combustion all round the edge, and the small lid closed. The rise in temperature is to be carefully observed, the degree at which a slight explosion occurs and extinguishes the flame being the degree of inflammability. Should this be either  $32^{\circ}$ ,  $33^{\circ}$ , or  $34^{\circ}$  C., the operation is to be twice repeated with fresh portions of the sample, and the average of the three taken as the correct result. Liquids passing the test of  $35^{\circ}$  C. are considered as of the second class, and those failing to do so are held to belong to the first class, of inflammable liquids.

The directions issued by the maker of the Granier cup are as follows:—To ascertain the flashing-point, the oil is poured carefully into the central cone surrounding the wick until the outer division is full to the level of the overflow-pipe. The wick should project not more than 1 mm. above the apex of the cone. After putting on the cover of the cup, a light is applied to the central orifice, when, if the oil disengages vapour at a lower temperature than the surrounding air, a flash is immediately obtained. In all cases where no flash is observed, the wick is lighted, the small lid on the cover is shut down, and the apparatus is kept in a still atmosphere. The small wire placed over the flame

<sup>1</sup> *Compt. Rend. Soc. Encour.*, 1872, No. 15.

conducts heat to the oil, and when the temperature reaches the point at which inflammable vapour is evolved, a flash occurs at the orifice in the lid, putting out the light. To determine the density of the oil, a specific-gravity instrument is supplied with the tester, graduated in degrees of  $2\frac{1}{2}$  grams per litre at a standard temperature of  $15^{\circ}$  C. This is a preliminary test, and obviates the necessity of the flash-test in the case of oils lighter than 0.760, these always taking fire below  $0^{\circ}$  C. The standard of density in France is 0.800 for petroleum, and 0.815 for shale-oil.

The author has made a considerable number of tests with the Granier apparatus, but has found the action so unsatisfactory that he is unable to state how the results compare with those given by the Abel instrument.

The **Luchaire** apparatus for determining the flash-point of kerosene and mineral lubricating oils (up to  $350^{\circ}$  C.) is provided with a bath, which in testing burning oils is filled with water, and in testing lubricating oils is filled with colza oil, and an inner vessel to contain the oil to be tested. The inner vessel has a cover which carries the thermometer, and in this cover there is a tubular orifice or short chimney and two openings for the admission of air. These orifices remain permanently open, and just above the top of the tube or chimney a small flame furnished by a colza-lamp, with a horizontal wick-tube, supported by a vertical rod, is kept burning during the progress of the test. The bath is heated by means of gas or an oil-lamp, and the temperature of the sample to be tested is thus, in the case of kerosene, raised at the rate of  $3^{\circ}$  C. a minute. When the vapour emitted from the sample escapes through the chimney and ignites, producing an explosion, the temperature is noted and recorded as the flashing-point of the oil. Difficulty in securing concordant results has been experienced in employing this apparatus.

**Parrish's "Naphthometer."**—In Parrish's naphthometer, an automatic tester which has been largely used in Holland,<sup>1</sup> the cover of the oil-cup is provided with a wick-holder, fixed centrally in a short tube of greater diameter, and carrying a lamp-wick which passes down into the oil. The oil thermometer is inserted in a tube which is attached to the cover of the cup. This tube communicates (1) with the external air through orifices in the cup at the upper end, (2) with the air in the upper part of the oil-cup through a lateral aperture, and (3) with the oil in the cup through openings in the bottom of the tube. A screen prevents the heat of the test-flame from affecting the thermometer. The oil-cup fits in a water-bath which is placed in an outer casing containing the spirit-lamp for heating the apparatus. In applying the test, cold water is poured into the water-bath, and the oil-cup is filled to within 1 centimetre from the top. The flame of the spirit-lamp is regulated to a length of 1 to  $1\frac{1}{2}$  centimetre, and the testing-flame should not exceed 6 or 7 millimetres in length. The heat from the latter causes a current of air to pass down the tube containing the thermometer, over the surface of the oil, where it mingles with the oil vapour, and to issue near the test-flame, ignition occurring when the flashing-point of the oil is reached.

**The Parrish-Engler Naphthometer.**—Parrish's instrument having been found by Engler and Haass<sup>2</sup> to give variable results according to the rate of heating, the size of the test-flame, and the degree of shelter from draughts afforded to the flame, an improved form was devised by Engler; an air space between the water-bath and the oil-cup being provided as in the Abel tester, and an ebonite ring interposed to prevent contact at the top. A glass chimney supported on a swing bracket can be brought into position over the test-flame. The lid of the oil-cup is fitted with a slide, by means of which the ventilating and testing

<sup>1</sup> *Zeitschr. anal. Chemie*, xx, 21 (1881).

<sup>2</sup> *Ibid.*, 23.

apertures may be closed or opened. The air entering the cup is directed over the surface of the oil by a semicircular screen, attached to the under surface of the lid and extending below the surface of the oil. This screen is pierced with holes for passage of the air. The correct heights of the heating- and test-flames are indicated by small wires projecting from the upper surface of the lamp and of the test-cylinder respectively.

The water-bath is completely filled, and the oil to be tested is poured into the oil-cup up to the level of the indicator. The oil-cup lid being fastened in position, the glass chimney is turned so as to enclose the test-cylinder, the heating-lamp is lighted, and when the thermometer indicates an approach to the anticipated flashing-temperature, the test-lamp is also lighted. The slide is then withdrawn for five seconds and quickly returned. This is repeated every degree Centigrade until flashing occurs. The apparatus is stated to give good results even in the hands of unskilled operators, provided the proper quantity of oil and the time named for opening the slide are correctly observed.

**The Phlog-elaio-mètre.**—The instrument sold under this name has been officially adopted by the city of Marseilles. It is described by the maker as consisting of a water-bath heated by a spirit-lamp, and a covered oil-vessel fitted with a thermometer. At the side of the thermometer there is a small chimney furnished with a wick of two or three strands of cotton, and near this there are two openings in the cover which are closed by a latch. The following are the directions for use:—Fill the water-bath to the horizontal line marked, so that the level of the water is a little below the two overflow-openings when the oil-cup has been inserted. The oil-vessel is to be filled with the oil to be tested up to the level of a horizontal ring which is fixed in it, and the lower part of the thermometer is to be passed through this ring. The wick in the

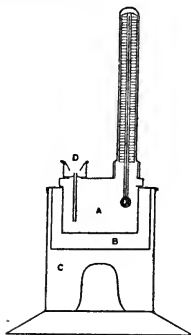

FIG. 235.—  
FOSTER AUTOMATIC TESTER.

chimney must pass into the oil, and should be cut off close at the top. Open the latch, light the heating-lamp, regulating the flame so that the temperature of the water may be raised very slowly. When the thermometer begins to rise, light the wick in the little chimney, and watch the thermometer. When the flashing-point is approached, the test-flame begins to flicker and is finally extinguished, the temperature indicated by the thermometer when this occurs being the flashing-point of the oil.

**The Foster Automatic Tester.**—The Foster automatic tester (fig. 235), employed in Ohio, is similar in principle to the original Parrish's tester. In the figure, the oil-cup is shown at A, the water-bath at B, the body of the apparatus, forming an air-jacket, at C, and the flash-jet at D.

The instrument consists of a copper lamp-furnace containing a water-bath and oil-cup, the latter surmounted by a closed vapour-chamber, which is pierced at two points symmetrically placed for the reception of a thermometer and a flashing-lamp or taper. The apparatus is elliptical in shape, the thermometer being placed in one focus of the ellipse, and the flashing-taper in the other. The flashing-taper consists of a small cylindrical wick-holder, which is supported by radial arms attached to a ring, and rests upon a similar ring at the bottom of an open, shallow basin, the spaces between the radial arms giving egress to the oil-vapour, while the wick itself extends down into the

body of the oil within the cup. An inverted conical thimble, resting upon the rim of the basin, prevents the dissipation of the vapour. The thermometer is mounted in a copper tube cut away in front to expose the scale, the bulb of the thermometer, when in position, being within the body of the oil at a definite distance below the surface. A space around the tube of the thermometer, of definite diameter and distance above the surface of the oil, allows of the passage of a downward current of atmospheric air when the flashing-taper is alight. An index is placed within the water-bath, and within the oil-cup, for maintaining uniformity in the filling of each. The heating-lamp of the lamp-furnace has its wick adjustable to regulate the rate of heating.

#### DIRECTIONS FOR USE.

1. Remove the thermometer, with its mounting, from the oil-cup.
2. Lift off the oil-cup containing the flashing-taper, and half fill the open water-bath with water.
3. Now take out the wick-holder from the oil-cup, and fill this vessel with the oil to be tested, pouring in the oil at the place of the wick-holder, and—noting the gauge-mark at the thermometer hole—pour in the oil very gradually as the surface approaches the gauge-mark. The gauge-mark consists of a small pendant shelf, and the oil-cup is properly filled when the upper surface of the oil just adheres to the lower surface of the gauge-mark. Too much care cannot be taken at this point; therefore, having ceased pouring, tip the cup so that the oil flows away from the gauge, and then gradually restoring it to the horizontal, see that the surface again adheres, and add a little more oil if it does not.
4. See that the wick of the flashing-taper be adjusted to give a very small flame—a flame that does not exceed one quarter of an inch in height. A flame that exhibits as much blue at its base as yellow at its top is right.
5. Now replace the oil-cup in the water-bath; return the flashing-taper to its place, inverting the conical thimble around it, and return the thermometer to its place upon the cup; in doing this be sure that the casing of the latter is pushed down upon the cup as far as it will go.
6. Half fill the lamp beneath with alcohol, light it and put it in its place beneath the water-bath. Now note the rate of increase in temperature as shown by the thermometer, and adjust the wick to raise the temperature at the rate of 2° per minute. When the temperature has reached 100°, light the flashing-taper and observe it closely. As soon as the oil under test has reached its “flashing-point,” the flame of this taper will be extinguished by the “flash,” and the temperature is to be noted at the instant the flame of the taper is extinguished.

Although the Foster tester belongs to the closed-vessel class, the author finds that it gives results from 14° to 20° F. higher than those furnished by the Abel instrument, the extent of the difference depending upon the character of the oil.

**Bernstein's Tester.**—In the Bernstein tester (fig. 236),<sup>1</sup> the water-bath contains a cylindrical oil-cup, F, which may be connected by a three-way cock, K, with either a U-tube, G, or a side-tube, J, which forms a gauge to indicate the height of the oil. The lid of the oil-cup is either closed by a tap at the top, or terminates in an open tube. Thermometers, T and C, are fitted in the water-bath and oil-cup. To apply the test, water is admitted from a reservoir, S, to the tube, G, and the pressure thus imparted to the oil expels some of the vapour from the oil-cup, so that it reaches a flame, *n*. To register the flashing-point, a second lamp-wick is placed just above the opening where the vapour escapes, so that it may become ignited when the flash occurs.

<sup>1</sup> *Sitz. Ver. Beförd. Gewerbfl. Preuss.*, 1879, 173, and *Dingler's polytechn. Journ.*, cexl, 136 (1881).

According to Engler and Haass, this apparatus gives trustworthy results if it is desired merely to ascertain whether a sample flashes at a given temperature or not; but if the object of testing is to ascertain the exact flashing-point, too much time is occupied, and a higher result is obtained than with the average of other closed-cup instruments.

**The Ehrenberg Tester.**—In the Ehrenberg tester, a syringe is employed to force the vapour from a closed oil-chamber into contact with a flame.

**Braun's Tester.**—Fig. 237 represents an instrument introduced by Braun.<sup>1</sup> It was originally constructed of glass, the oil-vapour being driven out against the test-flame by the pressure of water, but the metallic apparatus shown was afterwards employed. This consists of a steel block, A, weighing 6 kilos., the

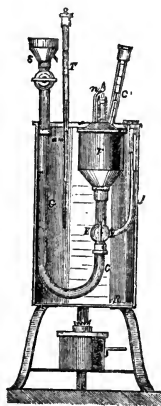

FIG. 236.—  
BERNSTEIN TESTER.

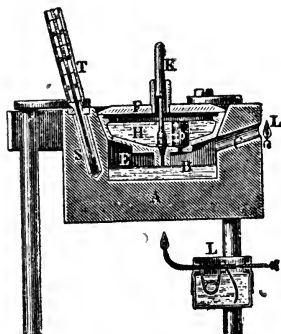

FIG. 237.—  
BRAUN TESTER.

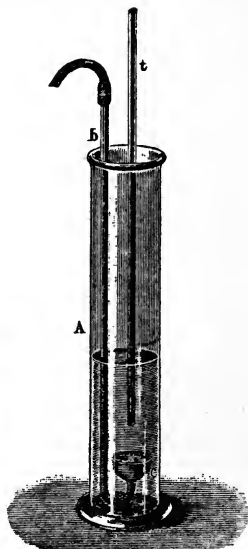

FIG. 238.—  
BEILSTEIN TESTER.

upper part, B, E, being hollowed out to a depth of 45 mm., and a diameter of 65 mm., and widened out conically at the top for the admission of a bronze cup, H. The cup has a truncated conical bottom with a downwardly projecting tube in the centre closed by a cork, fitted on a handle, K, rising up through the glass lid of the cup. A small cylinder, *b*, inside the cup, serves as a gauge, the superfluous oil running into it being removed by the aid of a pipette. The instrument rests on feet, to one of which a lamp, L, is so attached by a bracket, that the flame can be brought opposite an opening, C, in the side of the block. To apply the test, oil is poured into the upper cup, H, till the level of the upper end of *b* is reached. This measured quantity of exactly 25 c.c. is then run into B, E, by raising the handle, K, and a second 25 c.c. is similarly introduced into H. The steel block being previously heated to the required degree (indicated

<sup>1</sup> *Sitz. Ver. Beförd. Gwerbfl. Preuss.*, 1881, 212.



by a thermometer, T, inserted in a boring, S, containing petroleum), the oil is allowed to remain for 3 to 5 minutes to attain the same temperature, and after a total lapse of ten minutes from the pouring in of the oil, the test-flame is applied to the passage, C, and the handle, K, raised, allowing oil to run into B, E, to displace the vapour, which is forced out through C against the flame. If the mixture is explosive, the flame is extinguished.

**Beilstein's, Stoddard's, and Liebermann's Methods.**—Beilstein,<sup>1</sup> Stoddard,<sup>2</sup> and Liebermann<sup>3</sup> consider that the best method of ascertaining the flashing-point of petroleum is to pass a current of air through the heated oil, and observe the igniting-temperature of the mixture of air and vapour evolved. Stoddard passes a continuous current, which gives less accurate results than the intermittent method pursued by Liebermann and Beilstein.

**Beilstein's Instrument.**—This instrument (fig. 238) comprises a glass cylinder, A, 175 mm. high and 35 mm. in diameter, marked at distances of 60 and 70

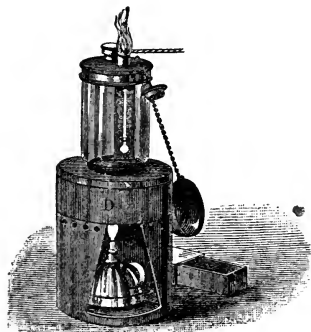

FIG. 239.—MILLSPAUGH TESTER.

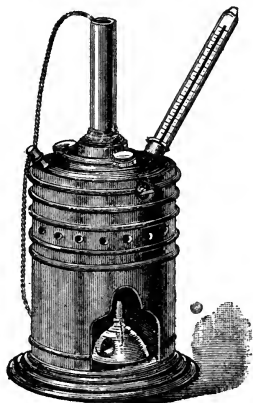

FIG. 240.—MANN TESTER.

mm. from the bottom, the lower mark indicating the oil-level. Air is blown in through a tube, *b*, terminating in a rose, *c*. A thermometer, *t*, is used to record the temperature, its bulb being immersed to about half the depth of the oil. The apparatus is placed in a slowly-heated water-bath, to produce a rise in temperature of about 1° C. in two to three minutes, and at each 1° rise a current of air is blown in for five seconds with sufficient violence to cause a froth to rise up to the higher mark on the cylinder, a small flame being at the same time applied to the mouth of the apparatus. The first flashing-point observed must be considered as a preliminary test, and the experiment must be repeated by commencing the introduction of the air current at the temperature noted. When the heating is carefully performed, the results are said to agree within  $\frac{1}{4}$ ° C.

**Millsaugh's Tester.**—In the Millsaugh closed tester (fig. 239) the glass oil-cup is immersed only to the extent of one-tenth of its depth in the water-bath, apparently with the object of preventing overheating of the surface of the oil.

<sup>1</sup> *Zeitschr. anal. Chemie*, xxii, 309 (1883).

<sup>2</sup> *Amer. Chem. Journ.*, iv, 285 (1882).

<sup>3</sup> *Zeitschr. anal. Chemie*, xxi, 321 (1882).

**Mann's Tester.**—In Mann's tester (fig. 240), an attempt is made to reproduce the conditions existing in an ordinary petroleum lamp, the burner of the lamp being replaced by a tube fitted with a stopper which is blown out when the vapour ignites on the introduction of a light through a lateral opening.

**Vette's Instrument.**—An apparatus designed by Vette for ascertaining whether an oil may be safely used in a lamp whose fittings have a known conductivity and capacity for heat, rather than for determining the actual inflammability of the oil as ordinarily understood, was described in 1882.<sup>1</sup> A water-bath fitted with a thermometer is filled with water up to an indicator-point, and maintained at the required temperature, generally about 30° to 35° C. An oil-vessel, fastened in the water-bath by a bayonet

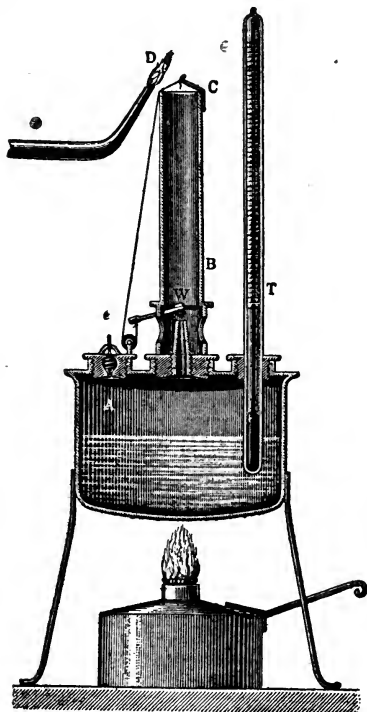

FIG. 241.—GAWALOWSKI TESTER.

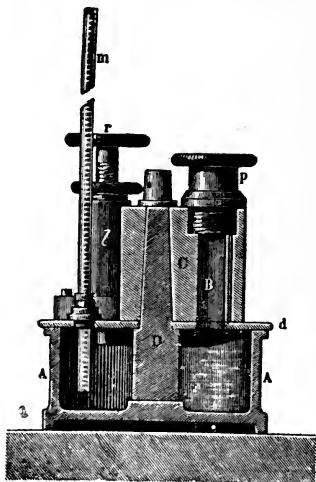

FIG. 242.—SALLERON-URBAIN TESTER.

catch, is charged with the oil as high as an indicator-point, and is covered by a hood surrounded by a second water-bath heated to 20° C., the average temperature of a room. After the apparatus has stood for fifteen minutes, the mixture of air and vapour in the hood being agitated by a stirrer, the test-flame is applied. If an explosion is produced, its effect is manifested by the lifting of a safety-valve.

**Gawalowski's Instrument.**—A. Gawalowski, of Brünn, introduced an apparatus which he asserted would show the degree of danger from explosion in a badly constructed lamp. In this instrument (fig. 241), A is the oil-cup, to the lid of which is affixed a Bunsen burner, B, a safety-valve and a thermometer,

<sup>1</sup> *Dingler's polytech. Journ.*, cexliii, 476.

T, fitted gastight. At the mouth of the Bunsen burner is soldered a hook, C, from which a thread impregnated with nitrate of ammonia passes round a pulley and supports a lever carrying a stopper, W, placed over the central tube. On heating the oil in the receiver, and applying a light, D, to the mouth of the Bunsen burner, the flame produced when the vapour ignites destroys the thread, and allows the stopper to drop into the mouth of the central tube. The temperature at which this occurs is read off on the thermometer.

**The Salleron-Urbain Tester.**—In the Salleron-Urbain tester, which has been used in France in the examination of petroleum, the flashing-point is deduced indirectly from the pressure exerted by the vapour evolved at a given temperature. It consists, as shown in fig. 242, of a copper or brass vessel, A, from the bottom of which rises a conical pillar, D. The vessel is hermetically closed by a cover, *d*, which carries a guide-block, C, fitting and pivoted on the pillar, D, and containing a cylindrical chamber, B, closed above by a screw-stopper and indiarubber ring, *p*, and communicating below with A by a hole in the lid. A graduated tube of glass, *m*, 35 centimetres long, and divided into millimetres; a thermometer; and a regulator consisting of a stuffing-box, *l*, containing a piston raised or lowered by a screw, *r*, to adjust the pressure of water in the tube, *m*, are all fastened hermetically to the lid.

**Directions for Use.**—To test an oil, water is poured into the vessel, A, and the lid with its appendages is fastened down, the block, C, being so turned that the cylinder, B, is not in communication with A. The oil being placed in B, and the stopper screwed down, the whole apparatus is placed in warm water until the thermometer indicates the required temperature. The height of the column of water in *m* is reduced to 0 on the scale by turning the regulating screw, *r*, and the block, C, is turned round so as to allow the oil to flow from B into A. The heat in the vessel, A, vaporises a portion of the oil, and the pressure generated is recorded by the rise of water in the graduated tube. The inventors prepared the following table showing the pressure produced by heating a "normal petroleum" free from all constituents of less than 0.735, or more than 0.820 specific gravity:—<sup>1</sup>

TABLE CXXXIX.—SALLERON-URBAIN TESTER.

Temperature.	Pressure expressed in Millimetres of Water in the Measuring Tube.	Temperature.	Pressure expressed in Millimetres of Water in the Measuring Tube.
°C.		°C.	
0	34.5	18	73
1	36	19	76
2	37.5	20	79
3	39	21	82.5
4	41	22	86
5	43	23	90
6	45	24	95
7	47	25	100
8	49	26	105
9	51	27	110
10	53	28	116
11	55	29	122
12	57	30	129
13	59	31	136
14	61.5	32	144
15	64	33	155
16	67	34	163
17	70	35	174

<sup>1</sup> *Ann. Gen. Civ.*, v, 154 (1866).

Salleron and Urbain give also the following as the determined vapour-pressures (vapour-tensions) of petroleum-products of various densities:—

TABLE CXL.—RELATION OF DENSITY TO VAPOUR-TENSION.

Density at 15° C.	Tension in mm. of Water.	Density at 15° C.	Tension in mm. of Water.
0·812	0	0·756	125
0·797	5	0·735	410
0·788	15	0·695	930
0·772	40	0·680	1185
0·762	85	0·650	2110

As regards this test, Engler and Haass state that the method rests entirely upon the belief that vapour-pressures vary directly with the flashing-points of different varieties of petroleum, a belief not in all cases correct, as the presence of a small quantity of highly volatile hydrocarbon, presumably too small in quantity to affect the flashing-point sensibly, increases the pressure in the apparatus. The conclusion is, however, expressed that oils whose vapour-pressure at 15° C. is not greater than is represented by a column of 64 millimetres of water, may be considered safe.

**Rosenblatt's Test.**—To estimate the flashing-point of samples too small for use in an ordinary tester, Rosenblatt has proposed the following indirect method:—<sup>1</sup>

A glass flask two-thirds full of water is fitted with an indiarubber stopper, with two perforations, one of which is connected with a Welter's safety tube containing a little mercury, while the other carries a bent glass tube. Into a Wolff's bottle of 100 to 150 c.c. capacity is poured 12·5 c.c. (10 grams) of the petroleum and an equal quantity of distilled water. Through the cork in one of the necks of the bottle is passed a glass tube reaching nearly to the bottom of the bottle, where it tapers off to about 1·5 millimetre diameter; the other end is in connection with the flask. The bottle is covered with a hood to prevent loss of heat, and its other neck communicates with a Liebig's condenser, delivering into a measuring-glass which holds 5 to 6 c.c. and is graduated to 0·05 c.c. Heat is applied to the flask until 5 to 5·1 c.c. of distillate collects in the graduated glass, and an equal quantity in a second glass after removing the first. After cooling to 15° C., the volume of oil and water is read off, and the flashing-point is found by the use of the following table, which is based on experiments made with the oils mentioned:—

TABLE CXLI.—FLASHING-POINTS IN ROSENBLADT'S TEST.

Petroleum flashing at °C.		Proportion of water to oil in distillate.
20	from Tagieff's works at Baku,	1 : 0·697
21		1 : 0·673
22		1 : 0·650
23		1 : 0·626
24	„ Mirzoeff's „ „	1 : 0·598
25		1 : 0·572
26	„ Kokoreff's „ „	1 : 0·549
27		1 : 0·526
28	„ Nobel Bros' „ „	1 : 0·504
29		1 : 0·483
30		1 : 0·464
45	„ American oleonaptha (lubricating oil),	1 : 0·328

<sup>1</sup> *Chem. Zeit.*, x, 1587 (1886).

To obtain more trustworthy results, double the quantity, viz. 25 c.c., of oil may be used, in which case 10 c.c. of distillate must be collected in the first glass. Notwithstanding that the influence of variations of atmospheric pressure prevents anything like absolute accuracy, the originator of the test believes it to be correct to  $\pm 1^\circ$  C. It is recommended to distil a sample of some "normal petroleum," and make the necessary corrections for variation of pressure, from the result obtained.

**Test Tube Method.**—When only a small quantity of oil is available for testing, the flashing-point may be approximately determined by slowly heating the oil in a test tube 4 or 5 inches in length by about three-quarters of an inch in diameter, and inserting the burning end of a piece of thin twine into the mouth of the tube at intervals, after agitating the oil. The tube should be about one-third filled with the oil, and a delicate thermometer used to take the temperature. In this way, results which do not differ materially from those furnished by the Abel instrument may be obtained after a little practice.

**Comparison of Results.**—In a report in 1882 to the New York State Board of Health, Professor A. H. Elliott furnishes particulars of experiments made with various testing-instruments, and gives the following table of comparative results obtained with them:—

TABLE CXLII.—COMPARISON OF SYSTEMS FOR TESTING FLASHING-POINT.

Oil used.	I.	II.	III.	IV.	V.	VI.	VII.	VIII.	IX.	X.	XI.
	Flashing-points, ° F.										
No. 1, . . . . .	110°	118°	120°	111°	117°	107°	103°	130°	111°	95°	119°
No. 2, . . . . .	111°	121°	124°	115°	118°	109°	102°	128°	107°	96°	...
No. 3, . . . . .	119°	122°	122°	112°	118°	108°	102°	130°	108°	95°	118°
No. 4, . . . . .	97°	96°	97°	90°	93°	86°	76°	90°	81°	75°	96°

I. Tagliabue (open cup). II. Arnaboldi (open cup). III. Saybolt. IV. Tagliabue (closed cup—small). V. Tagliabue (closed cup—large). VI. Wisconsin State. VII. Abel. VIII. Bernstein. IX. Millspaugh. X. Mann. XI. Foster.

**Testing for Petroleum-Vapour.**—The subject of the detection and measurement of petroleum-vapour in the atmosphere of tanks and other spaces engaged the attention of the author many years ago. He was at one time accustomed to employ an alcohol flame in testing for petroleum-vapour, but becoming impressed with the importance of being provided with a delicate and thoroughly trustworthy means of determining the proportion of inflammable vapour present, he was led to investigate the subject. After experimenting with various methods of testing, with results given in a paper already referred to in the section of this work dealing with Transport and Storage,<sup>1</sup> the author devised, in consultation with Professor Clowes and Mr. Robert Redwood, and with the assistance of Messrs. W. J. Fraser & Co., a testing apparatus in which the hydrogen flame is employed (English Patent, No. 187 of 1893). It is well known that a non-luminous flame, burning in a space from which light is excluded, in air containing a small proportion of inflammable gas or vapour, is seen to be surrounded by a faint halo, which is termed the "flame-cap." The advantage possessed by a hydrogen flame over other flames in point of sensitiveness when thus employed as a test for inflammable gases has long

<sup>1</sup> "On the Transport of Petroleum," *Proc. Inst. Civ. Eng.*, cxvi (1893-94), Part II.

been recognised, and Mr. Pieler<sup>1</sup> in 1883, after referring to the previous recommendation of the hydrogen flame for testing by Messrs. Mallard and Le Chatelier,<sup>2</sup> described an apparatus in which the gas generated in a Döbereiner lamp was burned in a specially constructed test-lamp, for use in testing samples of air from the workings in coal mines. Professor Clowes is entitled to the credit of having devised a form of miners' testing-lamp which depends for its success upon the employment of hydrogen stored under pressure. In the Redwood testing-lamp compressed hydrogen is also used. This lamp and its accessories have now been in practical use for the past twenty-five years, and have been found to answer the purpose admirably.

The complete appliances are shown in figs. 243 and 244.<sup>3</sup> They consist of the lamp, A, the reservoir of compressed hydrogen, B, and the sampling-vessel, C, in which the sample of air for examination is collected. The lamp is shown in section in fig. 244. A is the hydrogen inlet-tube, with the regulating valve, B, and C is the hydrogen-jet. D is the inlet-tube, for the sample of atmosphere to be tested. The bore of this tube is greatly contracted, and immediately above the point at which this tube enters the base of the lamp is an arrangement of baffles, surmounted by three discs of wire gauze of at least 28 wires per lineal inch, or not less than 784 openings per square inch, the flow of the gaseous mixture to the flame being thus regulated, and passage of flame into the collecting vessel being prevented. The chimney, E, fits airtight at the base, but is capable of vertical movement on an inner tube, the front of which is removed. The chimney is partly of metal and partly of glass, the metallic portion being blackened inside, and on the glass window lines corresponding with various heights of flame-caps may be marked. The top of the hydrogen jet-tube is 10 millimetres (0·4 inch) below the bottom of the window. Attached to the base of the lamp is a telescopic support for a cloth, which envelops the head of the observer and excludes light when the testing-apparatus is used in an undarkened room. The construction of the collecting-vessel is shown in section in fig. 244. A is the compression-pump, which is furnished with a metallic spring-piston, fitting the pump-cylinder without the use of leather or other material, and lubricated with plumbago. Surrounding the pump is an annular space, in which the sample of atmosphere is stored. B is a collar to which may be attached a flexible suction-tube of any desired length. C is a cock, to which is connected a copper tube conveying the sample to the test-lamp. The bore of this cock is very much reduced. D is a pressure-gauge, and E is a spring-valve lifting at 30 lbs. pressure. F F are hinged brackets, on which the feet of the operator are placed while the pump is being worked. A handle is provided, by which the cylinder can be conveniently carried. The capacity of the pump is 14·84 cubic inches, and of the annular space 169·14 cubic inches, thirty double-strokes of the pump being required to charge the vessel to a pressure of 30 lbs. per square inch, when it will contain  $\frac{1}{3}$  cubic foot of the atmosphere sampled. The collecting-vessel is fitted with a relief-valve, as the apparatus is often used in places in which the dial of the pressure gauge cannot be easily seen. The hydrogen-cylinder may be of any desired size, but the author has found that what is known as a 5-feet cylinder is of convenient dimensions. When charged to the usual pressure of 120 atmospheres, it holds enough gas to supply a 10-millimetre flame for ten hours, and is quite portable. The whole apparatus may be packed into two small boxes, and may thus be readily taken on board a ship.

<sup>1</sup> *Über einfache Methoden zur Untersuchung der Grubenvetter.* Aachen, 1883.

<sup>2</sup> *Ann. d. Mines*, sér. 7, xix, 186-211 (1881).

<sup>3</sup> The apparatus is supplied by the sole makers, W. J. Fraser & Co., Dagenham, Essex.

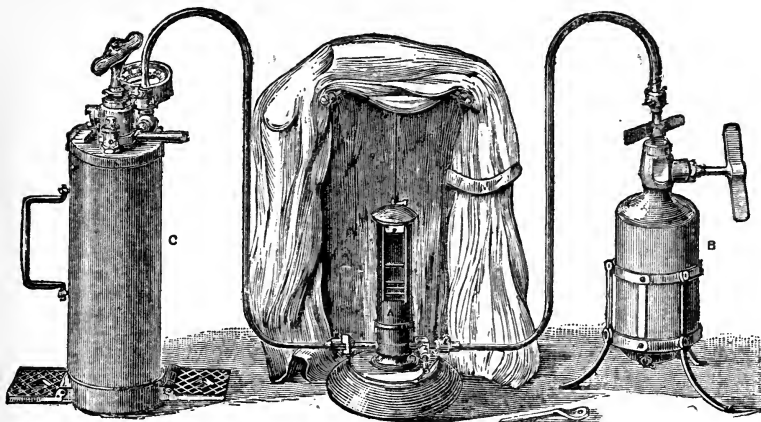

FIG. 243.—REDWOOD VAPOUR-TESTING INSTRUMENT.

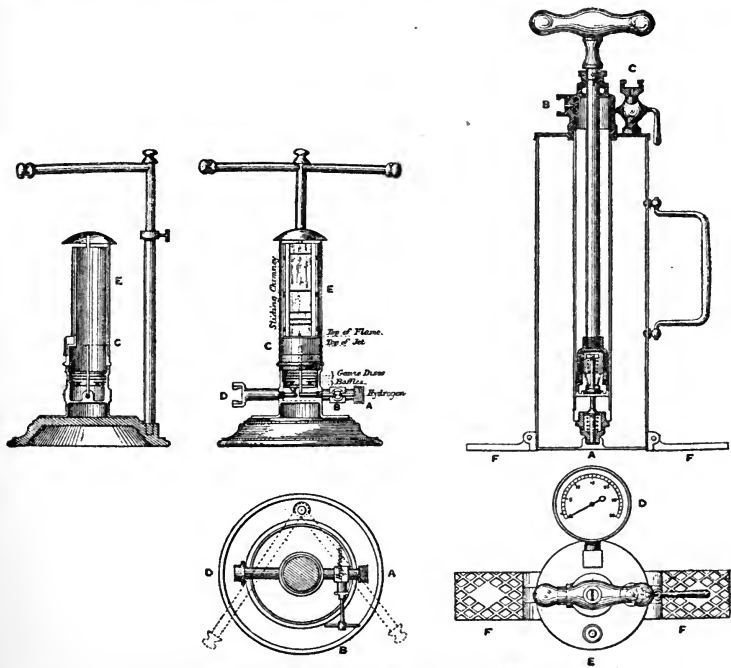

FIG. 244.—TESTING-LAMP, AND, COLLECTING-CYLINDER (REDWOOD).

In the use of the apparatus, the first step is to connect the hydrogen-cylinder with the lamp, taking care that the unions are screwed up gastight. The sliding chimney of the lamp being raised about half-way, the gas is then cautiously turned on at the cylinder, the regulating-valve on the lamp being left open, and a light is applied to the hydrogen-jet. The valve on the hydrogen-cylinder is then adjusted so as to give a flame rather more than 10 millimetres (0.4 inch) in length, and the lamp-chimney pushed down until there is an opening of only about a quarter of an inch in height at the bottom. This opening is left for the supply of air to the hydrogen-flame during the few minutes occupied in the warming of the chimney. As soon as the moisture which at first condenses upon the cold glass has evaporated, the lamp is ready for use, and assuming the collecting-vessel to have been already charged with the sample to be tested, and connected with the lamp, all that remains is for the observer to completely close the sliding chimney of the lamp, adjust the hydrogen-flame by means of the regulating-valve on the lamp, so that the tip of the flame is only just hidden when the eye of the observer is on a level with the bottom of the window, place his head under a cloth, such as is used by photographers, so as to exclude light, and as soon as his eyes have become sufficiently sensitive, turn on the tap of the collecting-cylinder, and carefully observe what takes place in the lamp-chimney. The tap may at once be turned on fully, as the contraction of the outlet- and inlet-orifices, already referred to, prevents the sudden rushing-out of the contents of the cylinder, and the sample will be gradually delivered into the test-lamp during a period of more than two minutes, which is ample time for noting the effect. The rate of delivery is, of course, a gradually diminishing one, but this is not found to be attended with any inconvenience, the conditions being the same in each experiment. In this way a proportion of vapour, considerably below that which is required even for the production of an inflammable mixture, and still lower than that which is needed to give an explosive atmosphere, may be detected by the formation of a flame-cap of greyish-blue colour, which, though faint, is nevertheless easily seen, especially after a little practice. With an increase in the quantity of vapour, the flame-cap first becomes much better defined, though it is not greatly augmented in size, and then considerable enlargement of the cap occurs, this condition being arrived at before the atmosphere becomes inflammable. The author and his brother, Mr. T. Horne Redwood, have succeeded in obtaining photographs of flame-caps, which are reproduced in the frontispiece of Vol. III, and convey an accurate impression of what the observer has to look for in employing the hydrogen-flame in the quantitative testing of air containing, or suspected to contain, petroleum-vapour. A represents the standard hydrogen-flame burning in air free from petroleum-vapour, and B, C, D, E, and F show the flame-caps produced when the vapour of 0.75, 1.5, 3, 5, and 6 volumes of pentane, respectively, are mixed with 100,000 volumes of air. In each case, a hydrogen-flame 10 millimetres (0.4 inch) in height was employed. In taking these photographs, the lens of the camera was placed equidistant from the hydrogen-flame and the sensitised plate, so as to give an image of true size. On the assumption that, in these experiments, the theoretical volume of vapour was obtained from the pentane, the proportions of vapour in the air were for B, 0.144 per cent. ; for C, 0.288 per cent. ; for D, 0.576 per cent. ; for E, 0.96 per cent. ; and for F, 1.15 per cent. Since the results given in the section on Transport and Storage (see p. 708, Table CXXVIII) show that the vapour of 6.65 volumes of pentane in 100,000 volumes of air is the smallest proportion giving an inflammable atmosphere, and that this proportion must be nearly doubled to give an explosive mixture, it follows that the proportion which furnished the



flame-cap, B, was about one-ninth of that necessary for the formation of a combustible mixture, and about one-eighteenth part of that which produces an explosive mixture. The test is, therefore, a delicate one; and it is obvious that, if the interior of a tank or other space be ventilated until a sample of the atmosphere gives no flame-cap with this apparatus, an ample margin of safety will be provided.

In taking a sample of the air in a tank, the collecting-vessel may be used in the tank, if the proportion of vapour present is known to be small, but even in such cases it is better to employ a short suction-tube, the open end of which can be placed at the lowest point in the tank, where most vapour would probably be found. If, on the other hand, the atmosphere of the tank is suspected to contain so much vapour that there would be danger of its producing insensibility when taken into the lungs, and especially if the compartment is entered through a small manhole, it would obviously be most improper that anyone should be sent into the tank, and in that case the sample should be taken by the use of a long suction-tube reaching to the bottom. It is evident that in the case of those tank-steamships which have spaces not filled with oil, but in which oil-vapour is liable to accumulate, there would be no great difficulty in having a system of small tubing permanently fitted, which would admit of a sample of the atmosphere being at any time drawn off by means of the collecting-cylinder in a part of the ship set apart for the purpose, so that a periodical testing of the atmosphere might thus be effected during the voyage or at any other time.

An instrument for detecting the presence of inflammable gas or vapour in air has been invented and patented (Eng. Pat., No. 22,129 of 1906) by Mr. Arnold Philip, Admiralty Chemist, and Mr. L. J. Steele, also of H.M. Dockyard, Portsmouth. This apparatus, which depends for its action upon the rise in temperature of a platinum or palladium wire over which a current of air containing inflammable gas or vapour is passing, has been fitted in a steamship employed by the Admiralty in the carriage of petroleum spirit, and is so arranged that air may be drawn for testing from any part of the cargo-space. The presence in the air of a smaller proportion of petroleum vapour than that which would be a source of danger is indicated by means of an electrical arrangement for ringing a bell and displaying a red light.

## LUBRICATING OILS.

**Specific Gravity.**—Mineral lubricating oils of similar character were formerly graded solely with reference to their specific gravities, but as it has been shown that there is no necessary relation between specific gravity and lubricating value, it is now generally accepted that the determination of specific gravity is of less importance than that of viscosity. The methods of ascertaining the specific gravity of oils have already been sufficiently referred to.

**Colour.**—In the case of what are known as "pale oils," exception is taken to any marked increase in the ordinary depth of colour, although there are no generally accepted standards of colour such as have been fixed for kerosene.<sup>1</sup>

**Lovibond's Tintometer.**—For some years the Lovibond tintometer<sup>2</sup> has been used in the laboratory of the author for determining the colour of a 2-inch column of lubricating oils, and comparative results have thus been furnished

<sup>1</sup> In Baku, Stammer's chromometer (see p. 762) is employed in recording the colour of lubricating oils.

<sup>2</sup> *Journ. Soc. Chem. Ind.*, 10 (1890), and Patent Specifications, 1886, No. 12,867; 1887, No. 3859; and 1890, No. 6221.

for the guidance of the trade. The instrument consists of a covered trough or box (fig. 245) divided longitudinally by a partition terminating in a vertical knife-edge opposite an eyepiece fixed at one end, two channels being thus formed, which slightly diverge from the end at which the eyepiece is placed. The oil to be examined is contained in a rectangular cell having glass ends

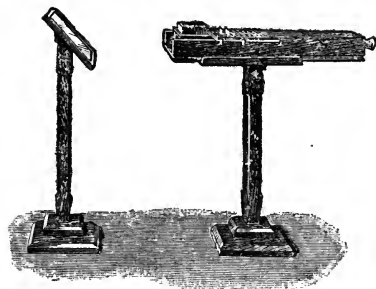

FIG. 245.—LOVIBOND TINTOMETER.

which is placed in one of the channels, and numbered slips of stained glass of known depth of tint are inserted in the other channel until the colour of the oil is matched.

In order to obtain accurate determinations of the colours of oils of high opacity, cells 1 inch and  $\frac{1}{2}$  inch in length are necessary. The tinted standard glasses used are the Lovibond yellow series 500.

It may sometimes be necessary to match a colour for future reference, and in these cases the use of tint glasses of the red and

blue series (Nos. 200 and 1180) affords a means of recording any colour to a minute degree of accuracy.

**Determination of Flashing-Point and Fire-Test—Pensky's Instrument for High Temperatures.**—Pensky was the first to construct for the testing of lubricating oils an instrument which resembles the Abel apparatus. The instrument (fig. 246) consisted of a metallic oil-cup, fitted with a stirrer, C, having a flexible handle, J, and two thermometers, one for the oil, and the second for the vapour-space. The oil being poured in up to the gauge, F, the cup was either placed in a glass beaker containing water, the temperature of which was gradually raised, or it was otherwise heated, a uniform temperature being maintained in the cup by the aid of the stirrer. From time to time, a small gas-flame was passed over an opening, L, in the lid until a flash took place. If the oil- and vapour-thermometers did not indicate the same temperature, the mean was taken.

**The Pensky-Martens Tester.**—This instrument, which is a modified form of the Abel apparatus, is largely employed for determining the flashing-point of lubricating oils by the close test. In fig. 247 the apparatus is shown with the test-flame in position for igniting the vapour; the cover of the oil-cup being shown in plan and side view, and a forked holder, for removing the oil-cup, in the separate figures.

*Description of the Instrument.*—The cover of the oil-cup consists of two parts—viz. the portion joined to the rim, and an upper portion which revolves through a small arc. In each portion there are three orifices, the central one being twice the area of the two lateral ones. These orifices may be made to coincide, or the openings may be completely closed, according to the relative positions of the two portions of the cover. The lower part of the cover is fitted with a vertical rod serving as a support to a tube. This tube can be rotated upon the rod by turning the non-conducting milled head at the upper end, and the action compresses a spring. At the lower end the tube is provided with an arm, which, by the action of the spring, is held against a vertical stud. A pin projecting downwards from the arm engages with a slot in the revolving portion of the cover, and on turning the milled head the openings in the upper portion

of the cover are brought over those in the lower portion. At the same time, a flange projecting from the edge of the revolving portion of the cover comes into contact with the oscillating test-jet, and this is depressed, so that at the same moment when the central openings coincide, the test-flame is brought to the orifice. On releasing the pressure requisite to turn the milled head, the openings in the cover are again closed by the action of the spring, and the test-jet is brought back to the horizontal position by the weight at the opposite end. This weight is attached to a stem forming a screw-valve, by means of which the size of the test-flame can be adjusted. The gas is supplied through a lateral tube forming one of the supports on which the jet oscillates, the other

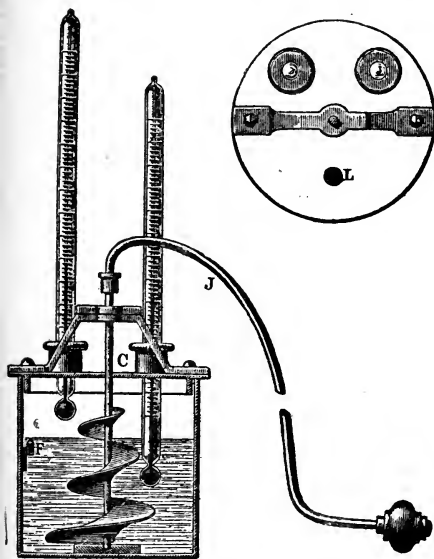

FIG. 246.—PENSKY TESTER.

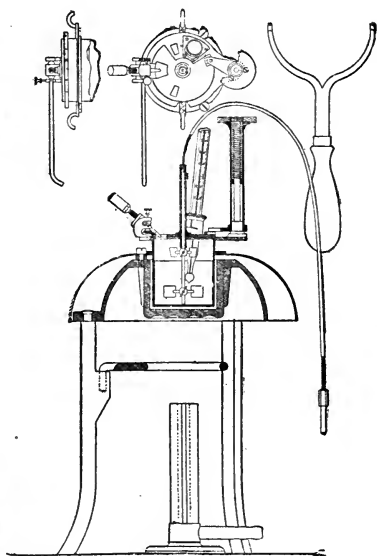

FIG. 247.—PENSKY-MARTENS TESTER.

support consisting of a small stud. In the lower part of the cover of the cup, there is a socket for a thermometer, and in the centre of the cover, there is a tube through which the stem of the stirrer passes. This stirrer is provided with a pair of arms working in the oil, and a smaller pair in the vapour-space above the oil. It is revolved by means of a flexible wire stem. The oil-cup has an engraved line on the inside to indicate the level to which it is filled for testing, and is furnished with a pair of hooks for convenience in removing it from the bath, when hot, by means of the forked holder shown. The heating-vessel consists of a cast-iron air-bath with an annular chamber exposed to the flame, and a brass jacket, which serves to check radiation. The jacket is separated from the iron casting by a considerable space at the sides and by a distance of a quarter of an inch at the top. The oil-cup rests upon the jacket, and therefore does not come into contact with the cast iron. Beneath the bath there is a disc of wire gauze which is fitted to a swinging arm, so that it

may be turned aside, and the flame of a Bunsen burner allowed to impinge upon the bath, when a high temperature is required.

The author is accustomed to regulate the flame of the burner so that the temperature of the oil rises at the rate of about  $10^{\circ}$  F. per minute, and to test at every rise of  $2^{\circ}$  F. In employing this, or any other form of close-test instrument in the testing of lubricating oils, it is important that the samples should be free from water, as the presence of aqueous vapour in the upper part of the cup prevents the occurrence of the "flash."

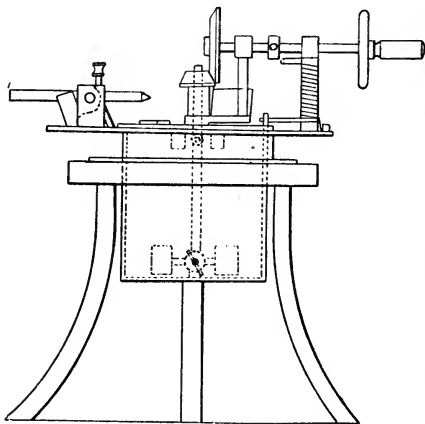

FIG. 248.

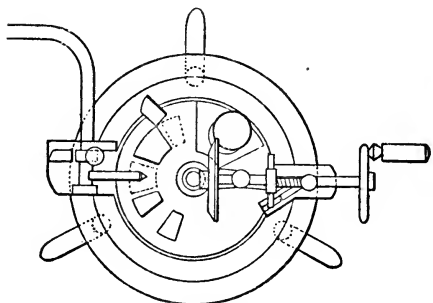

FIG. 249.  
GRAY TESTER.

If the cover of the oil-cup be removed, the apparatus may be employed as an open cup for determining the flashing- or igniting-point, a gas-flame not more than an eighth of an inch in diameter being used to produce the ignition.

The open- and fire-tests are determined by heating at the same rate, viz.  $10^{\circ}$  F. per minute, the "open-test" being the temperature at which the application of the test-flame causes the whole surface of the oil to be covered by the flash, and the "fire-test" the temperature at which the vapours are evolved freely enough to ignite and continue burning during a rise in temperature of at least  $2^{\circ}$  F.

**Gray's Tester.**—Figs. 248 and 249 show Gray's instrument for determining the flashing-point of heavy oils.<sup>1</sup> The apparatus consists of a brass oil-cup of the same dimensions as that employed in the Abel instrument, and covered with a tight-fitting lid through which passes a

steel shaft carrying on the end within the cup two stirrers, one for the oil and the other for the vapour. The cup is inserted in a heavy metal air-bath, similar to that of the Pensky-Martens instrument, and this is supported on a tripod stand. The upper end of the shaft terminates in a bevelled wheel engaging with another similar wheel on a horizontal shaft supported by two bearings and rotated by a handle fixed in an ebonite disc on its further extremity. This shaft also carries a collar

<sup>1</sup> *Journ. Soc. Chem. Ind.*, 348 (1891).

from which project two pins at diametrically opposite points. These, when the shaft is drawn out a little way so as to disengage the bevel wheels, come into position for applying the test-flame. In the lid are three openings—one immediately in front of the test-flame, and the others on either side of it. The sliding cover is pierced with two orifices corresponding to those on the lid, and is kept closed (as shown in fig. 249) by a spring while the bevel wheels are in gear. On drawing back the shaft, one of the projecting pins engages with the horizontal arm of an upright rod connected with the slide, which is turned round when the handle of the shaft is moved about a quarter of a revolution, the openings in the lid being thus uncovered and the test-flame simultaneously applied. Where gas is not available for the test-flame, a good substitute is obtained by passing a current of air or hydrogen through cotton wool or other absorbent material saturated with gasoline.

**Directions for Use.**—The following are the directions prescribed by the inventor:—The oil-cup being filled up to the mark inside with the oil to be tested, the thermometer is placed in its socket and heat is applied either by a direct flame or by the interposition of a sand-bath.<sup>1</sup> The test-flame is adjusted to a diameter of about one-eighth of an inch. During the heating, the stirrers should be rotated at short intervals, and in proportion to the rate at which heating progresses. When the expected flashing-point is approached, the heating should be more gradual, to ensure greater accuracy in the test, and a rough test to ascertain this point may be first made.

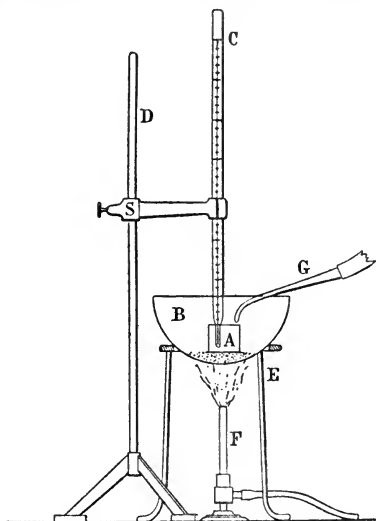

FIG. 250.—TREUMANN TESTER.

Observations may be taken every degree or half-degree, giving the stirrer a few turns before each.

**The Treumann Tester.**—The Treumann tester (fig. 250), employed for determining the flashing-point of mineral lubricating oils on the German State railways, is thus described by Künkler.<sup>2</sup> The oil-cup is a cylindrical porcelain crucible 4 centimetres high, and of the same internal diameter. It is filled with the oil to a distance of 1 centimetre from the top, and is placed on, but not enveloped by, a layer of sand  $1\frac{1}{2}$  centimetre deep, in a hemispherical iron or tin capsule 18 centimetres in diameter, supported on a tripod. A thermometer, the scale of which ranges from  $100^{\circ}$  to  $200^{\circ}$  C., is supported by a clamp, so that the bulb is completely immersed in the oil.

**Directions for Use.**—The bath is slowly heated, especial care being exercised when the temperature exceeds  $100^{\circ}$  C. to avoid local heating; and when the

<sup>1</sup> According to the author's experience a standard rate of heating of, say,  $10^{\circ}$  F. per minute should be maintained.

<sup>2</sup> *Die Maschinenschmierung* (Mannheim), 1894.

temperature at which the first test is to be made has been reached, the test-flame, which is 10 millimetres long and is supplied with gas through an india-rubber tube, is passed horizontally backwards and forwards over the oil, so that it is exposed to the vapour for a period of four seconds each time. Care must be taken that the flame does not touch the oil or the edge of the oil-cup. The test is applied first at 120° C., and afterwards at intervals of 5° until 145° C. is reached. Beyond this point it is repeated at intervals of 1° until a momentary flash occurs.

In fig. 250, A is the oil-cup; B, the sand-bath; C, the thermometer, supported by the clamp, S, on the rod, D; E, the tripod stand; F, the Bunsen burner; and G, the test-jet. In making the test, it is recommended that the jet, G, should be rested upon the edge of the sand-bath, and the flame moved slowly and regularly once forwards and backwards horizontally over the surface of the oil during four seconds, without coming into contact with the oil or the walls of the cup. This system of testing is referred to in greater detail in the *Mittheilungen aus den königlichen technischen Versuchsanstalten zu Berlin, herausgegeben im Auftrage der königlichen Aufsichts-Kommission*, 1893, part ii, 37, and certain defects are pointed out, preference being given to the Pensky tester.

**United States Fire-Test.**—In the United States it is customary to use, in ascertaining the fire-test, a shallow open metallic cup, supported on a tripod stand and heated directly by the flame of a spirit-lamp, the temperature being raised at the rate of 8° F. per minute.

**Volatility Test.**—In some cases the volatility of the oil is tested by noting the loss of weight sustained by a given quantity of the oil when exposed for a specified length of time in a shallow vessel, to an elevated temperature, the oil being sometimes absorbed by filter-paper before exposure to heat. The author is accustomed to expose 25 grams for twelve hours in a shallow dish, to a temperature of 150° F. in the case of engine- and spindle-oils, and 250° F. in the case of cylinder-oils. It is, however, difficult to prescribe any conditions under which concordant results can be always obtained, and the test is not a satisfactory one, according to the author's experience.

Mr. L. Archbutt has described<sup>1</sup> an apparatus which he employs in carrying out evaporation-tests of mineral lubricating oils. In this apparatus a measured current of 2 litres per minute of air or steam is passed for one hour through a tube, kept at a prescribed temperature (370° F. in the testing of cylinder-oils for use with a steam pressure of 160 lbs.), in which is placed a platinum tray, 3 inches long by  $\frac{1}{2}$  inch wide by  $\frac{1}{4}$  inch deep, containing 0.5 gram of the sample to be tested, and satisfactory comparative results are stated to be thus obtained.

**"Carbonisation Constant."**—In the lubrication of internal-combustion engines it is found that oils vary in the extent of their liability to become "carbonised," with the formation of an objectionable deposit in the cylinder, and there has been a demand for a test of what is termed the "carbonisation constant or carbonisation value" of oils. Mr. Alexander Duckham has devised an apparatus for applying such a test, which promises to afford valuable comparative results. The apparatus consists of a heating-chamber in which the oils to be compared are subjected to a pre-determined temperature for a specified length of time, with an ingenious contrivance, consisting of a slowly-revolving frame, actuated by clockwork, which ensures the subjection of the whole of the samples to similar conditions of heating. Mr. Duckham suggests that 2 grams of each oil, contained in a glass beaker having an average diameter of  $3\frac{1}{2}$  centimetres and a depth of 8 centimetres, should be exposed to a tempera-

<sup>1</sup> *Journ. Soc. Chem. Ind.*, xv, 326 (1896).

ture of 300° C. for 4 hours, that the loss of weight should then be determined, and the character of the residue ascertained. The beakers are placed in the revolving frame already referred to, and heat is applied by means of a gas-burner.

A valuable paper on deposits resulting from the lubrication of engines, read before the Manchester section of the Society of Chemical Industry, by Mr. Jas. Ed. Southcombe, will be found in the journal of that society, vol. xxx, pp. 261-263. The author remarks that it has usually been assumed that these deposits are solely due to the decomposition of the lubricant, and he shows that, although this explanation of their formation is in a large measure true, the decomposition is the outcome of a variety of chemical changes occurring during the use of the oil.

**Lubricating Value.**—The lubricating value of an oil is now usually deduced from its viscosity, though in some cases frictional tests are made with machines which will be described later.

**Determination of Viscosity.**—Although the results afforded by the use of a viscometer are purely arbitrary, and the viscosity as determined with one form of viscometer is not usually strictly comparable with that ascertained by means of another of different construction, yet each of the viscometers generally employed admits of being accurately standardised, so that any number of instruments of the same form may be constructed to give practically identical results. Viscosity is now regarded as one of the most important characters of a mineral lubricating oil, and several forms of apparatus for determining it are in use.

The Redwood viscometer has been adopted in this country by the Admiralty, the War Office, the principal Railway Companies, the Scottish Mineral Oil Association, and the petroleum trade generally, while the Engler viscometer occupies a similar position in Germany, and the Saybolt viscometer is largely used in the United States.

**Nasmyth's Apparatus.**—It is well known that practical men have long been in the habit of making a rough comparison between samples of lubricating oils by noting the length of time occupied in the flow of a given quantity over the surface of an inclined plate of glass. Probably the first instrument constructed for carrying out this test with some approach to precision was that of Nasmyth.<sup>1</sup> The apparatus consisted of a plate of iron 4 inches wide and 6 feet long, provided with six similar longitudinal grooves or channels. The plate was fixed so that one end was an inch higher than the other, and the oils to be compared were simultaneously poured in equal quantities out of a row of small brass tubes into the upper ends of the grooves, the rate of flow along the channels being carefully noted.

**Albrecht's Apparatus.**—Dr. M. Albrecht<sup>2</sup> improved Nasmyth's apparatus by suspending in a frame (see fig. 251), above the upper end of the channels, calibrated glass tubes, *a*, terminating in fine nozzles, *b*, of brass exactly over the centre of each groove. The apertures of the nozzles are closed by fine brass wires on the ends of the rods, *c*, connected by a crossbar, *d*, hanging from a bar, *f*, which is adjustable on supports, *e*, so as to admit of being lifted simultaneously at the commencement of the test, and replaced when a determined quantity has run from each tube.

**Phillips's Fluidimeter.**—An instrument devised by Mr. H. Joshua Phillips for determining the fluidity or viscosity of oils at various temperatures, is thus described by the inventor:—

<sup>1</sup> *Mechanics' Magazine*, liii, 313 (1850).

<sup>2</sup> Albrecht, *Die Schmiermittel*, 1879, 18.

“The instrument consists of a copper bath 14 inches long, 9 inches wide, and  $1\frac{1}{2}$  inch deep, provided with a stout gun-metal plate containing six cups and graduated grooves. It is swung upon elevated bearings from two studs projecting from the centres of the longitudinal sides, and can be fixed by means of thumb-screws. A protractor is fixed to the side, with an index upon the support, and the bath can be tilted at any desired angle to or from the operator. At the top of the bath are two holes, one for the thermometer, and the other for pouring in water or oil to be maintained at a definite temperature by a Bunsen burner. The grooves are 10 inches long, and graduated into  $\frac{1}{8}$  degrees. The surface is nickel-plated, and a stout glass plate is provided as a protection against air currents.”

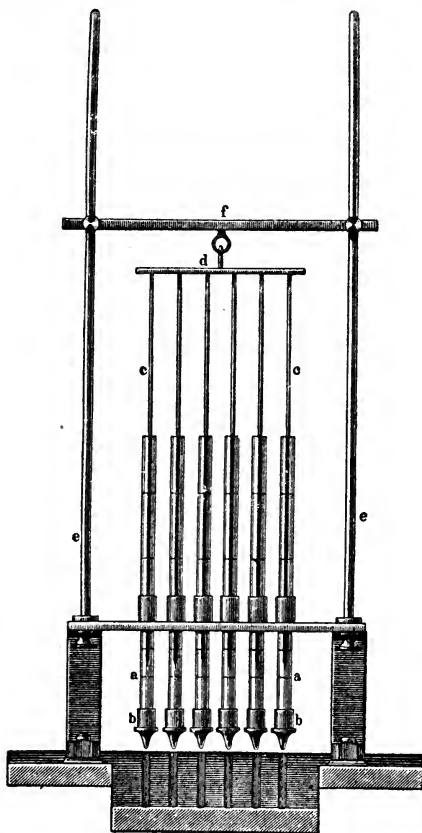

FIG. 251—ALBRECHT TESTER.

#### Directions for Use.—

“Water or oil having been run into the bath at any desired temperature, a small Bunsen burner is placed under the bath, regulated so as to maintain it at the same temperature. The oils to be tested are poured into test-tubes provided with pipettes, and heated in a bath of water or oil until the desired temperature is attained. The bath is now tilted at an angle of  $2\frac{1}{2}^{\circ}$  from the horizontal, from the operator, and the oils run into the cups until they reach the zero mark on the scale about an inch from the cups. The glass plate,

previously warmed to about the same temperature as the oils, is now slid on, the bath tilted at any desired angle to the operator, and the time noted that the oils take to reach the 10-inch mark. The time of flow of the oils is found to be practically inversely proportional to the angle of inclination, provided the angle is sufficiently great, or the temperature sufficiently high to allow the oils to run quick enough to minimise errors due to oxidation or cooling of the oil by air currents. This seeming deviation from the laws of gravitation is, of course, due to the decrease of acceleration consequent upon the loss of ‘head’ and



gradual loss in weight of the oil as it flows to the terminus. For instance, the following results were obtained with pure rape oil at a temperature of 180° F. :—

TABLE CXLIII.—PHILLIPS'S FLUIDIMETER, A.

Angle.	Distance.	Time in Secs.
2½°	10 inches	33
5°	10 "	16
10°	10 "	8

“ A sample of mineral engine oil gave :—

TABLE CXLIII.—continued. B.

Angle.	Distance.	100° F.	140° F.	180° F.
2½°	10 inches.	160	60	28
5°	10 "	79	30	14

“ From these results, it would appear that the time of flow could be calculated for any desired angle from one determination at a definite angle. The following results were obtained in comparing the viscosity of pure rape oil at different temperatures with Redwood's viscometer, assuming the rate of flow to be 1 at 180° F. :—

TABLE CXLIII.—continued. C.

At	Phillips's Fluidimeter.	Redwood's Viscometer.
180° F., . . . .	1·00	1·00
140° F., . . . .	1·59	1·56
100° F., . . . .	3·19	3·14
60° F., . . . .	7·50	7·37

“ The great advantage the writer (Mr. Phillips) has found in using the instrument is that in cases where several oils have to be examined and to be compared with a standard, a great saving of time is effected, inasmuch as all oils that do not approach the standard in fluidity can be discarded, and an exhaustive examination made only of the oils that agree in fluidity with the standard.”

**Pipette Viscometers.**—The simplest instrument for determining the viscosity of an oil consists of a glass pipette which is filled to a mark on the neck and allowed to discharge its contents. The relation between the time of outflow of the sample and that of a standard oil indicates the viscosity of the sample in terms of the standard. It is, however, difficult to standardise such pipettes, since the form of the constricted part, apart from the size of the opening, affects the result, and different pipettes standardised with an oil of a certain viscosity do not necessarily give concordant results with an oil of very different viscosity. The maintenance of the required temperature of a sample in a glass pipette is also not easily effected. For these reasons, the **jacketed glass viscometers** of Veitch-Wilson, M'Ivor, and Sacker have not been found to give sufficiently accurate results.

**Coleman-Archbutt Viscometer.**—One of the least unsatisfactory forms of pipette viscometer is Archbutt's improved form of the instrument first used by Coleman about 1869. The glass pipette, including the jet, is surrounded for practically its whole length by a water-jacket. Four marks etched on the pipette allow of the testing of either 25 c.c., 50 c.c., or 100 c.c. of oil. The jet of the instrument is about 1 inch in length, and its diameter such that 100 c.c. of rape oil take about ten minutes to run out at 60° F. Fig. 252 shows the Coleman-Archbutt viscometer.

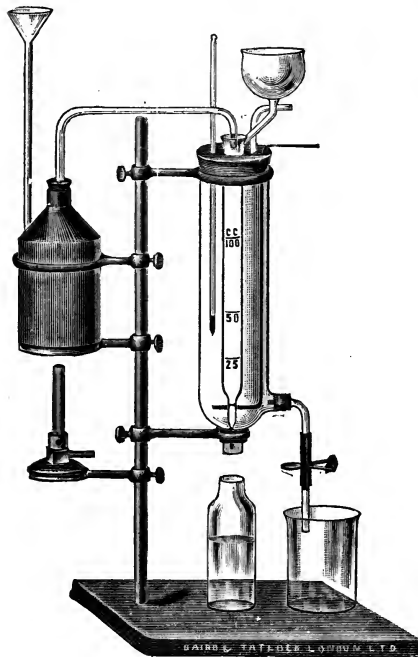

FIG. 252.—COLEMAN-ARCHBUTT VISCOMETER.

could be maintained at that height during the experiment:—

A glass cylinder 22 inches (55.9 centimetres) long,  $1\frac{1}{4}$  inch (3.18 centimetres) diameter, has a brass plate on the lower end an eighth of an inch (0.318 centimetre) thick. An orifice is bored in the centre of the plate  $\frac{1}{32}$  inch (0.0794 centimetre) in diameter, with bevelled edges, chamfered back half an inch (1.27 centimetre), thus producing a sharp-edged orifice. A line marking the 18-inch (45.72 centimetre) level is cut on the glass, with several finer lines above and below, an eighth of an inch (0.318 centimetre) apart, ranging from 16 to 21 inches (40.64 to 53.34 centimetres) above the orifice. The standard temperature is usually 60° F. (15.5° C.). A total flow of 6.103 cubic inches (100 c.c.) is recorded, after adjusting the supply so that the head shall be as nearly as possible equal to 18 inches (45.72 centimetres) of water, determining this head by calculation from the specific gravity of the oil. The rule for

**Napier's Viscometer.**—

The advisability of reducing the observed viscosity to a standard density, appears to have been first suggested by Mr. Napier, of Glasgow. In his instrument, the oil-cylinder consisted of two parts connected by a flexible tube. The upper part was so supported that it could be placed at a given height on a fixed scale, according to the specific gravity of the oil, and was provided with an overflow-pipe, so that, by using a reservoir with a stop-cock, a slight continuous overflow could be produced, and the oil-level thus kept constant.

**Mason's Viscometer.**—In

the *Chemical News* for 31st October 1884, Professor W. P. Mason, of Troy, N.Y., gave the following particulars of a viscometer in which the column of the oil could be so adjusted in height as to be inversely proportional to the specific gravity, and

obtaining the viscosity is to note the time required to discharge the 100 c.c. (6.103 cubic inches), and divide this time by that required where water under a head of 18 inches (45.72 centimetres) is used. This ratio is the measure of the viscosity.

**Redwood's Viscometer.**—The Redwood viscometer (figs. 253 and 254) is a modification, designed by the author in 1885, of the instrument formerly used at the Battersea Works of Price's Patent Candle Company. It consists of a silvered copper oil-cylinder,  $1\frac{3}{8}$  inches in diameter and  $3\frac{1}{2}$  inches in depth, furnished with an agate jet fitted into a slightly conical metal seating. The cylinder is fixed in a brazed copper water-bath provided with a copper heating-tube projecting downwards at an angle of  $45^\circ$  from the side near the bottom, as well as with a revolving agitator carrying a curved shield to prevent splashing and a thermometer to indicate the temperature of the liquid in the bath. The oil-cylinder has a stopper consisting of a small brass sphere which rests in a hemispherical cavity in the agate jet. The sphere is attached to a wire by means of which it is raised and hooked on to a clip which supports a thermometer in the oil. Inside the oil-cylinder, and at a short distance from the top, is fixed a small bracket terminating in an upturned point, which serves as a gauge of the height to which the cylinder is filled. The instrument is supported on a tripod stand, furnished with levelling screws. Great care is taken in the construction of the agate jets to secure uniformity, and any small differences in the rate of flow are corrected by slightly altering the position of the pointed bracket in the oil-cylinder. The instruments are thus all standardised. The viscometer is used in the following manner:—The bath is filled with a suitable liquid to a height corresponding with the point of the bracket in the oil-cylinder. Water may be used for temperatures up to  $200^\circ$  F., and a heavy mineral oil for higher temperatures. The liquid being at the required temperature, the oil to be tested, which may previously be brought to the same temperature, is poured into the inner cylinder until its level just reaches the point of the gauge. A narrow-necked flask, holding 50 c.c. to a point marked on the neck, is placed beneath the jet, in a vessel containing a liquid of the same temperature as the oil. The ball valve is then raised, a stop-watch at the same time started, and the number of seconds occupied by the outflow of 50 c.c. noted. When oils are being tested at a temperature much above that of the laboratory, a gas-flame is applied to the heating-tube, and the agitator kept in gentle motion throughout the experiment. The maintenance of the exact required temperature of the oil is thus, after a little practice, rendered easy. It is important that the apparatus should stand perfectly level, and that the oil should be free from dirt, water, or other suspended matters, and not have been heated very much above the temperature of the test during the preceding twenty-four hours. For very accurate determinations the apparatus should be enclosed in a glazed cupboard kept at the same temperature as the viscometer when the temperature at which the tests are being made is such as to admit of this being done. In order to express the results in terms of the viscosity of rape oil at  $60^\circ$  F., the standard used with this instrument, the number of seconds occupied by the outflow of 50 c.c. of the oil is multiplied by 100 and divided by 535, the average number of seconds occupied by the outflow of 50 c.c. of rape oil at  $60^\circ$  F. from the apparatus. The result is multiplied by the specific gravity of the oil at the temperature of testing, and divided by 0.915, the specific gravity of refined rape oil at  $60^\circ$  F., a correction being thus made for the difference in the specific gravities of the two oils.

The author attaches considerable importance to the employment of agate in

the construction of the jet, as this material is not liable to become worn or injured, even if the instrument is subjected to somewhat rough usage. He has

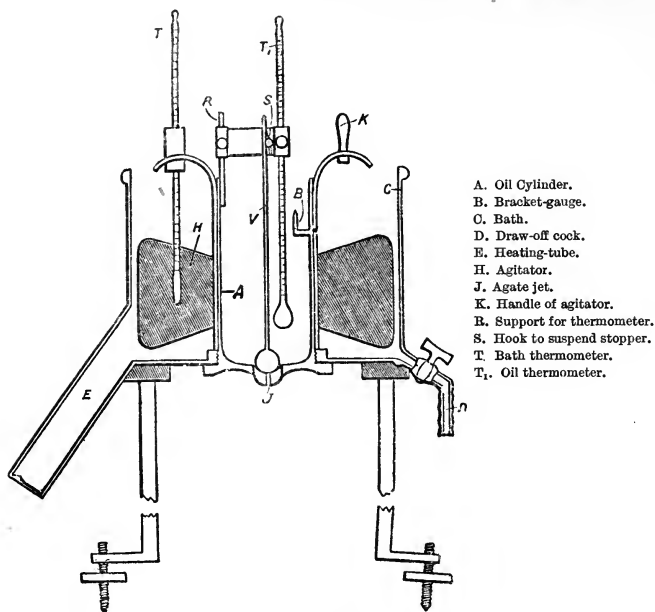

- A. Oil Cylinder.
- B. Bracket-gauge.
- C. Bath.
- D. Draw-off cock.
- E. Heating-tube.
- H. Agitator.
- J. Agate jet.
- K. Handle of agitator.
- R. Support for thermometer.
- S. Hook to suspend stopper.
- T. Bath thermometer.
- T<sub>1</sub>. Oil thermometer.

FIG. 253.

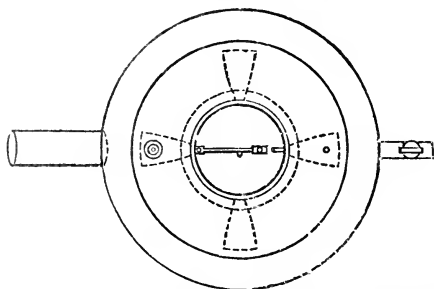

FIG. 254.

REDWOOD VISCOMETER.

had one of these viscometers in almost daily use in his laboratory at temperatures ranging from 70° to 250° F. for the past twenty-five years, and the jet shows no sign of wear. He also regards the provision of an effective stirrer for

the bath as highly desirable, for it is essential that the temperature of the oil subjected to the test should be most accurately adjusted and maintained. In the original standardising of the instrument, *slight* departures from the standard size of the orifice may be corrected by placing the gauge-point a little higher or lower. If, however, there be any considerable deviation from the model, especially in respect of the height of the column of oil, the instrument may be standardised to give the same results as the pattern with a certain oil, but will not necessarily furnish concordant results with another oil of different viscosity.

#### Redwood Viscometer (Admiralty Pattern).—

A modification of the ordinary type of Redwood viscometer just described, devised by the author for the special purpose of testing oil fuel according to the Admiralty specification, is shown in fig. 255. The design is registered and the sole makers are Messrs. Baird & Tatlock (London), Ltd.

The dimensions of the oil-cup are the same as those of the oil-cup of the ordinary viscometer, but the agate jet is longer and of larger diameter. The instrument, which is standardised, is particularly suitable for use at a low temperature.

The oil-cup is held rigidly in the "lagged" ice-jacket by an ingenious tripod arrangement.

The apparatus is supported on a substantial tripod stand, which is fitted with levelling screws and an adjustable table for holding the measuring flask under the jet of the viscometer.

The directions for use are as follows:—

The oil to be tested must be free from water, dirt, and matter in suspension, and should be maintained at a temperature of 32° F. for at least six hours immediately before it is tested. (A good plan is to put the oil in ice over-night and test after about sixteen hours.)

The thermometer is supported in the oil-cup by means of the clip, so that its bulb rests on the bottom of the cup, and in such a position that the flow of oil from the orifice will not be interfered with.

The oil-cup is filled with the cooled oil, so that the gauge-point is covered, and the apparatus is then transferred to an efficient ice-chest of suitable design and the instrument levelled by means of the tripod-screws and spirit-level provided for that purpose.

As it may be necessary to make more than one test, it will be found desirable to have at least half a pint of the oil in a stoppered glass bottle placed in the ice-chest with the instrument until required for use.

Before commencing a test, the level of the oil in the oil-cup is brought exactly to the point of the gauge. A narrow-necked flask, of 50 c.c. capacity to a mark on the neck, is placed beneath the jet and the ball valve raised and suspended from the thermometer-clip by means of the hook on the stem of the valve, a stop-watch being started simultaneously with the lifting of the valve. During the period of testing, the temperature of the oil must remain



FIG. 255.—REDWOOD VISCOMETER, ADMIRALTY PATTERN.

constant at 32° F. The time of outflow for 50 c.c. is noted, and the result given in seconds.

If the oil-cup requires to be wiped out, tissue-paper rather than cloth should be employed, as filaments of the latter may be left adhering to the surface of the vessel. The agate orifice must not be cleaned with anything which is likely to cause abrasion, and it has been found best to employ twisted tissue-paper for the purpose.

The instrument may be used at moderate temperatures for testing viscous oils or other liquids which do not flow readily from the ordinary type of viscometer at those temperatures, the ice-jacket being used as a water-bath. A revolving agitator, carrying a thermometer, and working in the bath, facilitates the regulation of temperature.

**Engler's Viscometer.**—The following description of the Engler viscometer is derived from the *Zeits. f. angew. Chemie* of 1892, and from *Dingler's polytechnisches Journal*, 1892, cclxxxvi, pp. 210–212:—

In 1884, at the request of the *Tarif-Kommission der deutschen Eisenbahnen* (Committee of the German State Railways), Dr. C. Engler experimented with a view to the construction of a viscosity instrument for mineral lubricating oils, and his apparatus was adopted by the *Kommission* in their report of 31st May 1884 as the official test on the railways. An account of it was given in the inventor's paper in the *Chemiker Zeitung*, No. 11 of 1885, 1st February.

Complaints having arisen with regard to the irregular results yielded by the instruments of different makers, which, although professedly standardised, exhibited fundamental departures from the original model, Dr. Engler, in 1892, brought out the improved form shown in the figure, and stated that the only instruments which would in future be recognised as normal were those made by C. Desaga, of Heidelberg, and bearing the standardising mark of the Grand Ducal Techno-chemical Testing and Experimental Institution in Karlsruhe. The apparatus (fig. 256) is provided with an oil-cup, A, of brass, closed by a lid, A<sub>1</sub>. The oil-cup is of the dimensions given in the figure, and its inner surface is gilt. In the centre of the convex bottom of the oil-cup is an outflow-tube, a, of platinum (brass being attacked by the oil after being some time in use) 20 millimetres long and 2.9 millimetres internal diameter at the top, decreasing to 2.8 millimetres at the outlet. This tube can be closed by a pointed rod, b, of hard wood, introduced through the lid of the cup. Three small pointed studs, c, turned up at right angles, on the walls of the cup, serve to indicate the surface-level of the oil, marking a capacity of 240 c.c., and also show whether the apparatus is properly adjusted as regards level. A thermometer, t, is inserted in the lid to register the temperature of the oil. The oil-cup is fixed in an open oil-bath, B, containing a thermometer, t<sub>1</sub>. The oil-bath is supported by a tripod stand, and is heated by means of a ring burner. A measuring-glass, C, marked at 200 c.c. and at 240 c.c., is placed exactly below the pipe, a.

To ensure the attainment of satisfactory results, the dimensions given must be strictly adhered to, for, although the error caused by altering some of them can be corrected, so far as the flow of water at 20° C. is concerned, by varying the length of the pipe, a, the correction is of no value for oils at other temperatures, and the difference in result between such instruments and one of standard dimensions increases with the viscosity of the oil tested.

Every instrument, even when standardised, should be tested before using the first time, and again after having been some time in use, by carefully rinsing out the cup with ether, alcohol, and water, in succession, carefully

drying the outflow-pipe with a strip of filter paper, and observing the time required for the outflow of 200 c.c. of water maintained at 20° C. The water should be quite free from any rotary motion before the vent peg is withdrawn. The time should be 51 to 53 seconds, and the test should be twice repeated. The difference should not exceed 0.5 second, and the decimals of the average are counted as one second. To test oils, the cup must be most carefully cleansed of all damp and dirt, rinsed with alcohol, ether, and petroleum in succession, and then filled with the oil up to the gauge points. The oil having been brought to the desired temperature by heating the oil-bath, and maintained at that point for two or three minutes, the peg is withdrawn, and the

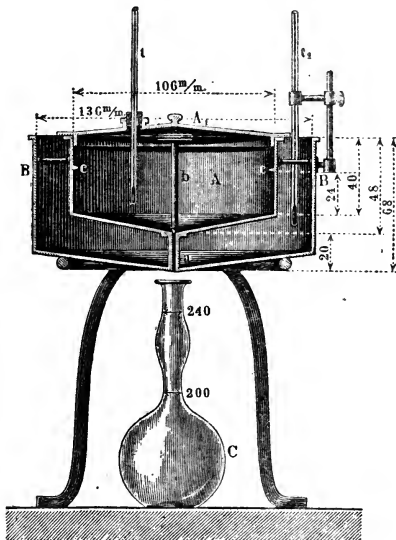

FIG. 256.—ENGLER VISCOMETER.

outflow timed by a good chronometer. The result in seconds, divided by the rate for water at 20° C., gives the viscosity of the oil, e.g.—

Rate of flow of oil, 276 seconds.  
 „ „ water at 20° C., 53 seconds. Result=5.2.

Oil containing suspended particles, solid matter, or water, must be filtered or dried before testing.

The results of a number of tests made in the author's laboratory indicate that an oil taking 100 seconds for the outflow of 50 c.c. at 70° F. from the Redwood viscometer would give an efflux time at 20° C. for 200 c.c. of oil from the Engler viscometer of approximately 170 seconds.

**Lamansky-Nobel Viscometer.**<sup>1</sup>—This instrument, in use in the laboratory of Nobel Brothers in Baku, has a water-bath, 285 millimetres in height and 115 millimetres in diameter, fitted with an annular perforated stirrer, a per-

<sup>1</sup> *Journ. Soc. Chem. Ind.*, 182 (1898).

forated steam-coil, and a thermometer. The oil-vessel is 300 millimetres in height, and in diameter it tapers from 50 millimetres in the upper half to 12 millimetres at the bottom, where a screw piece is fitted containing the effluent aperture (1 millimetre in diameter) closed by a metal valve. The lid of the oil-vessel fits airtight, and is pierced by a copper tube, 5 millimetres in diameter, the lower end of which is exactly 200 millimetres above the point of outflow. The oil-cup is also provided with a thermometer. The time of outflow of the sample tested is compared with that of 100 c.c. of distilled water at 50° C. (viz. 60 seconds) at a constant pressure of 200 millimetres.

**Saybolt's Viscometer.**—In the Saybolt viscometer (fig. 257) the oil-vessel is placed in a water-bath of considerable capacity. The jet of the viscometer is of metal, and is enclosed in a tube extending below the orifice. The oil-vessel is contracted, as shown, above the jet, and is cut away longitudinally on each side to expose a glass tube which lines it. Glass windows are provided in the water-bath. The upper edge of the oil-vessel is fitted with an oiltight gallery having a raised edge, and communicating with the oil-vessel, which extends to the same level as the top of the gallery, by a number of small holes. In using the apparatus, the water-bath is filled with water at the required temperature, and a cork having been inserted in the mouth of the tube enclosing the jet, the oil-vessel is filled with the sample to be tested until overflow occurs through the holes into the gallery. The oil is then stirred with a thermometer, and the temperature adjusted if necessary. On withdrawing the thermometer, the oil which it had displaced flows back from the gallery, which is then emptied by means of a pipette. The length of the oil-column is of course determined by the position of the holes connecting the oil-vessel with the gallery. The flow of oil from the jet is started by withdrawing the cork, and a stop-watch is set in motion. The watch is stopped when the operator sees the surface of the oil through the glass tube above mentioned.

Experiments conducted in the author's laboratory afford the following relationship between results obtained in the Redwood and Saybolt viscometers: 100 seconds outflow at 70° F. in Redwood viscometer equals approximately 56 seconds in the Saybolt instrument at the same temperature.

**Saybolt Universal Viscometer.**—In a personal communication to the author, Mr. George M. Saybolt describes the latest pattern of his viscometer (fig. 258). The instrument is adapted for use with either gas, electric, or steam heating, and is fitted with a stirring attachment. The directions for use are as follows:—

1. Set the instrument up level on a work bench or table, with the three legs of the jacket-stand gripping the outside edge of the eight-inch diameter concentric bored base block, S.

2. Fill the bath-vessel with pale engine oil of about 350 to 400° F. flash, to a height so that when heated to the prescribed temperature it is filled, and not overful after the turn-table cover is adjusted thereto.

3. Place the turn-table cover D in position.

4. Adjust the bath thermometer, B (or the two thermometers), through the "T" holes provided therefor, carefully down to and through the stirring paddles, K.

5. Adjust the electric immersion-heater, C, through the bath drip-cup down to and in the receptacle, M, provided therefor.

6. With the screw end of the connecting wire cords of the heater attached to a lamp-socket (or other electric current-supply fitting) attach the loose-fitting connection, at the other end of the cords, to the pins provided therefor in the heating element.



7. Turn on the current (100–125 V.) and periodically give turn-table several quarter turns, by means of handles, F, to the end that the uniform temperature looked for is arrived at.

Always take care that the temperature of the bath is not raised higher than the scale of the individual thermometer in use will accommodate, otherwise there is a great danger of breaking the thermometer due to the mercury column being driven to the top of the thermometer tube.

8. Have the oil to be tested passed through the strainer, Q, into one of the cups, T. (The oil may be previously heated to about the required test temperature.)

9. Clean out the oil tube, J, with some of the oil to be tested, by means of the plunger, V.

10. Place the small cork-stopper, N (as little a distance as possible), into the

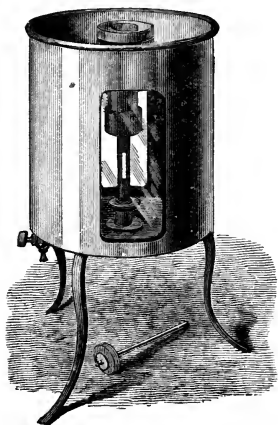

FIG. 257.—SAYBOLT VISCOMETER.

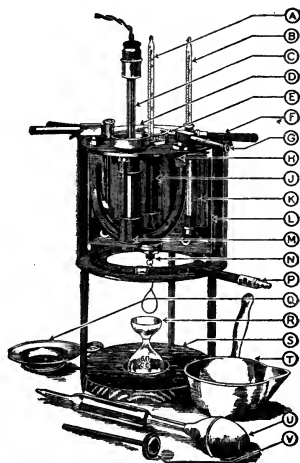

FIG. 258.—SAYBOLT STANDARD UNIVERSAL VISCOMETER.

lower outlet of the oil tube just enough to make an airtight closure. It is not intended to near touch the small outlet jet of the tube proper ( $\frac{1}{8}$  to  $\frac{1}{4}$  inch may be enough).

11. Pour the oil to be tested from the tin cup (again through the strainer) into the oil tube, until it overflows into the overflow cup, E, up to and above the upper edge of the tube proper.

12. Now again see that the bath is at the prescribed temperature, and that it is kept at this temperature during the running time of the test.

13. By using the oil-tube thermometer sent with the instrument as a stirrer, bring the oil that is in the tube to the uniform and test temperature desired.

14. Remove the thermometer from the oil tube.

15. By means of the pipette, U, draw off all the surplus oil down to and below the upper edge of the tube proper. This ensures a positive filling or starting head.

16. Place the 60-c.c. receiving flask, R, anywhere in the centre hole in the

base block; if against the sides of the hole in the block, the dropping oil slides into the 60-c.c. flask, without raising an air-froth, this permits plainly seeing the 60-c.c. scribe on the receiving flask and is conducive to the most accurate reading of the stopping point.

17. Now with the oil and bath at their prescribed temperatures, and with the watch in one hand, draw the cork with the other, and simultaneously start the watch.

18. The time in seconds required for the delivery of 60 c.c. is the viscosity.

The viscosity (seconds) divided by 30 equals the viscosity comparative with water at 15° C.

19. Clean out the tube proper before each test with some of the oil to be tested, by means of the plunger.

20. No drill or other hard instrument should ever be used in the small outlet jet of the tube proper.

21. If *absolutely* necessary, due to a thought that some foreign matter may be in the outlet jet, a piece of plaited fishing-line may be pulled lightly to and fro in the jet to thoroughly clean.

22. When not in use keep the tube covered.

23. The electric heater should be kept free of the non-conducting black carbonaceous matter that collects on its bulb, due to the superheating. To clean this material off, simply use the heater to boil some water, after which it easily rubs off.

24. By means of the inlet and outlet connections, G, the U-tube, H, can be used to introduce steam or hot water for heating, if electricity is not available, or for cold water if needed to cool down. The gas burner, P,<sup>1</sup> can also be used to heat with instead.

The following table for the conversion of viscosities given by the Saybolt Universal viscometer to the corresponding Redwood figures has been compiled from experiments conducted by the Bureau of Standards:—<sup>1</sup>

TABLE CXLIV.—CONVERSION TABLE FOR SAYBOLT UNIVERSAL AND REDWOOD VISCOMETERS.

Saybolt Time, seconds.	Factor to reduce Saybolt Time to Redwood Time.	Saybolt Time, seconds.	Factor to reduce Saybolt Time to Redwood Time.
28	0.95	70	0.87
30	0.95	75	0.86
32	0.94	80	0.86
34	0.94	85	0.86
36	0.94	90	0.85
38	0.93	95	0.85
40	0.93	100	0.85
42	0.92	110	0.85
44	0.92	120	0.84
46	0.91	130	0.84
48	0.91	140	0.84
50	0.90	160	0.84
55	0.90	180	0.84
60	0.89	200	0.84
65	0.88	1800	0.84

The following table, based upon actual experiments, of the ratio between results given by the Coleman-Archbutt, Engler, Redwood, and Saybolt visco-

<sup>1</sup> Report of Committee, D-2, American Society for Testing Materials, 1915.

meters was published in *Electricity* on April 11, 1919 (No. 1483, vol. xxxiii, p. 229):—

TABLE CXLV.—RATIO BETWEEN EFFLUX TIMES BY DIFFERENT VISCOMETERS AT THE SAME TEMPERATURE.

Viscometer.	
Coleman-Archbutt, 25 c.c., . . . .	0.48
" " 50 c.c., . . . .	0.78
" " 100 c.c., . . . .	1.19
Engler, 200 c.c., . . . .	1.75
Redwood, 50 c.c., . . . .	1.00
Saybolt, old type, . . . .	0.57
" "Universal," . . . .	1.19

**Absolute Viscosity.**—Attention is now being directed to the advantage which attaches to the expression of the results in terms of *absolute viscosity*, as explained in *Lubrication and Lubricants*, by Archbutt and Deeley, 1912. The generally accepted physical definition of viscosity enunciates that the viscosity of a substance is measured by the tangential force on unit area of either of two horizontal planes at unit distance apart, one of the planes moving with unit velocity relatively to the other, the space between these planes being filled with the viscous substance.

The units employed in expressing these terms are usually those of the C.G.S. system, the absolute viscosity being given in dynes per square centimetre.

It will be seen that the true or absolute viscosity is quite independent of any apparatus which may be used in its determination.

The figures obtained in the use of the well-known viscometers described have a recognised commercial value, although these results, as they are generally expressed, have not the purely scientific aspect that is requisite to a consideration of true viscosity as covered by the definition. It is possible, however, to convert time of outflow as given by either the Redwood or Engler viscometer to the corresponding absolute viscosity in C.G.S. units by means of simple formulæ based upon research work in this subject.<sup>1</sup>

The formula for the Redwood instrument is:—

$$\eta = (0.00260T_R - \frac{1.715}{T_R})\delta^*$$

where

$\eta$  = viscosity in C.G.S. units,

$T_R$  = time of outflow of 50 c.c. in seconds,

$\delta$  = density of the oil at the temperature of experiment.

The formula for the Engler viscometer is based on the work of Dr. Ubbelohde, amplified by experimental investigation at the National Physical Laboratory, and is applicable to an instrument of normal dimensions having fifty-one seconds as the time of outflow for distilled water at 20° C.

$$\eta = (0.001435T_E - \frac{3.22}{T_E})\delta$$

where  $T_E$  = time of outflow in seconds for 200 c.c.

The ratios of  $T_R$  and  $T_E$  may be calculated for any value of  $T_R$  by combining the two formulæ. The ratio  $\frac{T_E}{T_R}$  for  $T_R = 40$  seconds is 1.83, and for

<sup>1</sup> National Physical Laboratory, *Collected Researches*, vol. xi, pp. 1-16.

$T^R=100$  seconds is 1.815; for values of  $T^R$  above 100 seconds the ratio is 1.81.

An article in *Electricity* for April 18, 1919 (No. 1484, vol. xxxiii, p. 237) gives the following values for  $\kappa$  for the calculation of absolute viscosity from results given by the Coleman-Archbutt, Engler, Redwood, and Saybolt viscometers by means of the formula.

where	$\eta = \kappa(td)$ ,	
	$\eta$ = absolute viscosity,	
	$\kappa$ = a constant,	
	$t$ = time of outflow in seconds,	
	$d$ = specific gravity at temperature of experiment.	
	For Coleman-Archbutt viscometer	(25 c.c.) $\kappa = 0.0050$ .
	" "	(50 c.c.) $\kappa = 0.0031$ .
	" "	(100 c.c.) $\kappa = 0.0020$ .
	" Engler viscometer,	(200 c.c.) $\kappa = 0.0013$ .
	" Redwood viscometer,	(50 c.c.) $\kappa = 0.0024$ .
	" Saybolt viscometer, old type,	$\kappa = 0.0042$ .
	" Saybolt viscometer, "Universal,"	$\kappa = 0.0020$ .

These values are not applicable to either very thin oils or to thick oils which are tested at high temperatures, but hold good for oils having an absolute viscosity between 0.4 and 8.0 dynes per square centimetre.

Savill and Cox<sup>1</sup> suggest the use of straight-line graphs prepared from results obtained in the Redwood viscometer and the absolute viscosities for the conversion of Redwood viscosities to the corresponding absolute viscosities, and *vice versa*.

**Engler and Künkler's Modification.**—In order to overcome the objection to the Engler viscometer when used at high temperatures, that the end of the outflow-tube is liable to cool below the temperature recorded, Engler and Künkler devised the following apparatus<sup>2</sup>:—The outer casing (see figs. 260 and 261) is of octagonal section, and is 35 centimetres high and 20 wide. It is made of stout brass plate, and is double walled. It stands on four triangular feet, *a*, the slanting sides of which rest on the inner edge of the ring of a tripod stand, so that the instrument is easily levelled. On the bottom is screwed a concave heating-plate, *b*, for distributing the heat from a Bunsen flame. A tripod, *c*, resting on this plate supports a graduated receiving-flask, *e*, protected by asbestos cloth, *f*, and above this is placed a horizontal plate, *g*, having a central aperture, *h*, for the descending oil, and four oval ascending tubes, *i*, reaching up to the level of the oil-cup and serving to equalise and distribute the heat. The oil-cup, *k*, rests on four feet above the dividing plate, and is fitted with a thermometer, *s*; a filling-tube, *v*; a two-bladed stirrer, *p*, moved by a handle, *o*, above (but only through one-third of a revolution, so as not to interfere with the thermometer); and a pointed rod, *t*, for closing the outflow-tube—all of which, as well as a thermometer, *u*, for the air-chamber, project through the glass lid of the apparatus.

The stirrer can be lifted out of the oil, and supported by a projecting pin, when not in use. There are two windows, *m*, on opposite sides, level with the top of the oil-cup, and two double windows, *l*, on opposite sides of the lower chamber. The oil, before being placed in the viscometer, is warmed to the required degree in a double-walled can (fig. 259), fitted with a thermometer and a stirrer, *x*. The blades of the stirrer are fixed at different heights on the spindle, so as to promote circulation of the oil from below upwards. The bottom of the can is covered with asbestos cloth. It was found by the inventors

<sup>1</sup> *Journ. Soc. Chem. Ind.*, No. 3, vol. xxxv (1916).

<sup>2</sup> *Dingler's polytech. Journ.*, cclxxvi, 42 (1890).

that up to 100° C. the distribution of heat over the interior of the apparatus was regular with the exception of the stagnant layer of air at the bottom of the viscometer, which was a few degrees lower. The latter condition was also observed at temperatures above 100° C. in increasing degree, amounting to 4° at 150° C., but the difference was not found to affect the result of the test.

The receiving-glass being placed on its stand, and the horizontal plate and viscometer inserted in the case, the lid is fixed in position, care being taken that the marks on the lid, viscometer, and plate, correspond with the mark on the edge of the case. The air-chamber thermometer is inserted so that its bulb almost touches the viscometer, and the bulb of the oil thermometer is also lowered as far as possible without touching the bottom of the cup. The filling tube, stirrer, and vent-stopper are all placed in position, and after levelling the

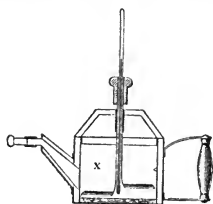

FIG. 259.

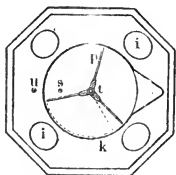

FIG. 260.

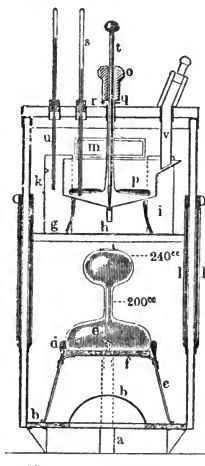

FIG. 261.

ENGLER-KÜNKLER VISCOMETER.

apparatus by the plumb-line at the side, heat is rapidly applied until four-fifths of the desired temperature is reached, when the flame is continuously decreased till the right degree is attained and remains constant, as indicated by the air-chamber thermometer.

Meanwhile the heating-can has been filled with oil nearly up to the mark, and carefully heated to the proper temperature, the stirrer being meanwhile moved in the direction of an arrow on the lid, and is then filled quite up to the mark. When both oil and apparatus are at the right temperature, the former is quickly poured into the viscometer, and the filling-tube is closed. After ascertaining that the oil reaches exactly up to the mark, the stirrer is moved (holding the vent-peg in position during this operation), and when the temperature is registered as correct, the stirrer is drawn up and suspended by its side pin, and the vent-peg is withdrawn, the hole in the stirrer-knob being closed by a peg provided for that purpose. The time required for the passage of 200 c.c. of the oil from the cup into the receiving-glass is the measure of the viscosity. It is well to allow the oil to exceed the required temperature by  $\frac{1}{4}^{\circ}$

or  $\frac{1}{2}^{\circ}$  before pouring it into the viscometer. If a little too hot, it may be cooled by slightly reducing the temperature of the air-chamber. It is important that the oil should not be heated or cooled too rapidly, as either affects its temperature during the transfer to the apparatus, and the stirrer should be well worked before reading the temperature or pouring out the oil.

**Engler-Künkler-Martens Viscometer.**—The Engler-Künkler viscometer has been further modified by Martens, as shown in fig. 262.<sup>1</sup>

The oil-cup, A, stands on a tripod in a double-walled chamber, B, having a glass door, D, at the back, and a glass disc in the front. The air-bath is heated by a curved burner, E, placed beneath wings, F, on the chamber, B. Thermometers, H, T, indicate the temperature of the oil and air. The oil is stirred by a platinum wire, K. The temperature may be regulated by temporarily opening the door, D. The oil is allowed to flow out by raising a stopper attached to a rod, G. This apparatus is readily cleansed, and being wholly contained in the air-bath, there is no risk of the oil being cooled as it flows from the vessel, A.

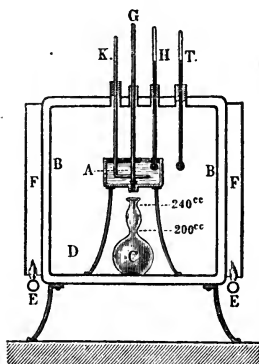

FIG. 262.—  
MARTENS VISCOMETER.

**Künkler's Modification.**—A. Künkler<sup>2</sup> has devised a modification of the Engler viscometer for use at low temperatures. The oil-cup, 6 centimetres in diameter, and containing, up to a mark, 75 c.c., rests on four feet in a refrigerating bath. The outflow-tube is 20 millimetres long and 7 millimetres wide, and can be closed by a pointed rod projecting through the lid. The draining-pipe of the cooling-bath is fitted with a pinch-cock. The whole rests on a truncated metal cone, which contains a graduated receiving-glass of 50 c.c. capacity, and serves to protect the outflow-tube from external heat. Two side windows admit of the inspection of the course of the test. The apparatus is levelled by set-screws. The instrument is standardised by observing the rate of outflow of glycerin, of 1.200 specific gravity (=24° Baumé)

at 17.0° C., previously cooled to 0° C., and allowed to stand five minutes in the oil-cup before testing, the outside bath being filled with ice-water. The test is applied as follows:—

Oil at 17° C. is poured in up to the mark, the lid is closed, and a refrigerating mixture giving a lower temperature than that required for the experiment is placed in the bath. The oil is then stirred with the thermometer until the requisite temperature is reached, whereupon the cup is closed, and water is poured into the bath until that is also of the same temperature. The temperature is carefully maintained throughout the test, by the application of water or cooling mixture, keeping the liquid up to within 1 to 1.5 centimetre of the lip of the bath. An hour is allowed to expire before the oil is run out. The time required for 50 c.c. of the oil to run through is compared with the glycerin standard.

**Künkler's Viscometer for Greases.**—Künkler<sup>3</sup> has devised the following

<sup>1</sup> See *Zeitschr. anal. Chemie*, xxxi, 583 (1893).

<sup>2</sup> *Dingler's polyt. Journ.*, cclxxxix, 137 (1891).

<sup>3</sup> *Dingler's polyt. Journ.*, cxcx, 281 (1893); see also Künkler's *Maschinenschmierung, die Schmiermittel und ihre Untersuchung* (Mannheim), 1894.

instrument (fig. 263) for comparing the relative consistency of machine-greases by their rate of flow under a given temperature (usually 50° C.) and pressure. It is made of brass, and has a water-bath, *a*, which can be maintained at a constant temperature by heating a side chamber, *g*. In the centre is fixed a cylindrical vessel, *b*, terminating in a small tube, *d*, 6 millimetres in diameter,

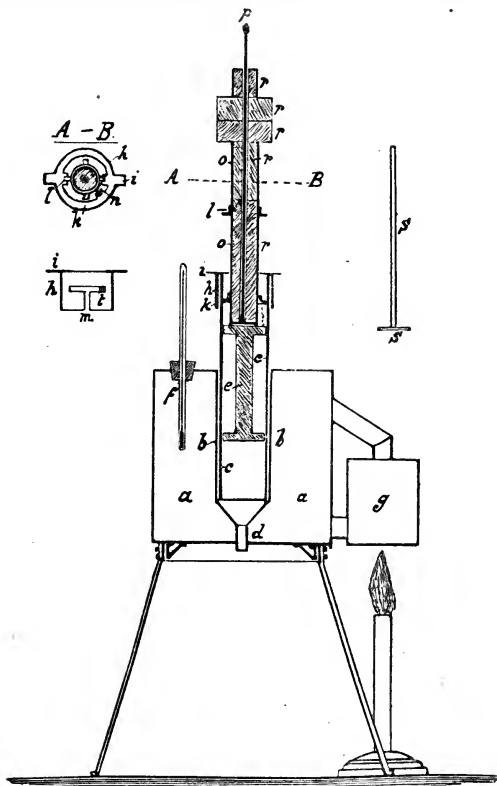

FIG. 263.—KÜNKLER'S GREASE-VISCOMETER.

and 15 millimetres long, projecting through the bottom of the bath. The bath is provided with a thermometer, *f*. A tube, *c*, 30 millimetres in diameter and 150 millimetres in length, fitting into the cylinder, *b*, contains the grease to be tested. A piston, *e*, 75 millimetres in length, and consisting of two circular plates 29 millimetres in diameter connected by a rod, slides in the tube, *c*, and presses the grease through the tube, *d*. The piston is continued above the upper plate as a tube, *o*, which, by means of a guide-strip fitting in a groove, *n*, is kept perpendicular. On the upper end of the tube, *c*, fits a cap, *h*, with

two opposite inward projections, *i*, its movement being restricted by a projecting stud fitting in a slot, *m*. The tube, *o*, is provided with four projecting studs, two upper, *l*, and two lower, *k*, which rest on the projections, *i*. The tube is thus supported by the lower studs until the test is commenced, when, on being slightly turned, it is free to descend until its movement is arrested by the upper studs. The two pairs of studs are 55 millimetres apart. In the tube, *o*, an upright rod, *p*, terminating below in a plate, serves to hold in place the weights, *r, r, r, r, r* (3 of 200 grams, 1 of 100 grams, and 1 of 50 grams). The weight of the piston and the rod, *p*, is 170 grams. As the consistency of greases is greatly affected by differences of temperature and by stirring, it is essential that the grease-tube, *c* (of which three are provided with each apparatus), should be filled twenty-four hours before the test is applied, and be kept at 20° C. The filling is accomplished by applying the grease with a knife or spatula to the lower plate of the piston, and gradually drawing the latter up the tube, taking care that no air-space is formed. The operation is completed by the aid of a ramrod, *S*, and the tube is full when the upper plate of the piston reaches the top of the tube. 50° C. is the usual temperature for the test. To ensure this, the bath is filled to 1.5 centimetre from the top, with water at 55° C., this temperature being maintained by the aid of the heating-lamp. The grease-tube, *c*, being placed in the cylinder, *b*, the piston is inserted, and the cap, *h*, placed in position to intercept the studs, *k*. After standing for twenty minutes during which time the weights are put in place, the cap, *h*, is turned round, and the piston allowed to descend until the upper studs rest on the edges of the cap, *h*, when the test is at an end, the time occupied being the measure of the consistency of the grease. According to the nature of the grease to be tested, the weights are varied so that the operation shall occupy about ten minutes; this is ascertained by an approximate preliminary test. The test is only a comparative one, there being no relation between the results obtained by using different weights. After each test, the piston should be cleaned and cooled, and the conical bottom of the cylinder, *b*, cleared of adherent grease.

**Künkler's Viscometer for Small Samples.**—In order to admit of the viscosity of a lubricating oil being determined with smaller samples than are necessary when the ordinary viscometer is used, Künkler<sup>1</sup> has devised a form of apparatus suitable for quantities as small as 30 c.c. The apparatus (fig. 264) is provided with an external oil- or water-bath, *w*, of sheet brass, with a copper bottom, cylindrical in form, and turned outwards at the top. Heat is applied to the bath by means of a spirit-lamp or gas-flame, and the temperature of the contained liquid is indicated by a thermometer suspended by a bracket-clip, *x*. In the bath is a movable stand, *d*, on four legs which extend to the circumference. The stand also has a pair of arms, *h*, which hook on to the bevelled edge of the bath. The viscometer proper rests on the stand, and is fastened to it by a spring clip, *i*. It is in the form of a double globular flask of strong glass, the two parts being connected by a capillary tube, *c*, 30 mm. in length. The upper globe, *e*, is 40 mm. in diameter and carries a filling-tube, *k*, 13 mm. wide and 65 mm. long. From the side of the lower globe, *a*, rises a tube, *b*, through which 25 c.c. of oil is drawn, by exhaust, from the globe, *e*, up to a mark, *g*. The globe, *e*, is furnished with a thermometer inserted through a loosely fitting cork in the filling-tube, *k*, and is etched with a filling-mark at a height of 35 mm. above the mouth of the capillary tube. The width of this latter tubing is such that distilled water at 20° C. would rise in it to a height of 50 mm. The height of the ascending tube, *b*, is 125 mm., and its internal

<sup>1</sup> *Dingler's polytech. Journ.*, ccxc, 281 (1893).



diameter 5 mm. This tube extends horizontally for a length of 75 mm., and is provided with a tap, *m*. A stay, *l*, fastens the tube, *b*, near the top to the rest of the apparatus. The exhaustion-apparatus consists of two globes united by a tube, *s*, the upper one, *r*, being 48 mm. in diameter and etched with a filling-mark, *p*, while the lower, *t*, is 56 mm. in diameter, and has a filling-tube, *v*, at the highest point. The vertical distance from the mark, *p*, to the centre of the lower opening of the tube, *s*, is 160 mm. The exhauster is connected with the viscometer by a strong indiarubber tube, 120 mm. long, joining the horizontal end of the tube *b* to another tube of the same length and inside diameter, and likewise fitted with a tap, *o*, extending from the globe, *r*. The apparatus is standardised by using an aqueous solution of glycerin of 1.110 specific gravity at 20° C., mercury being employed as the exhaust fluid. The rate of flow, per second, of the glycerin solution (the mean of three tests being taken) is the standard of comparison for oils, their viscosity being determined at the average

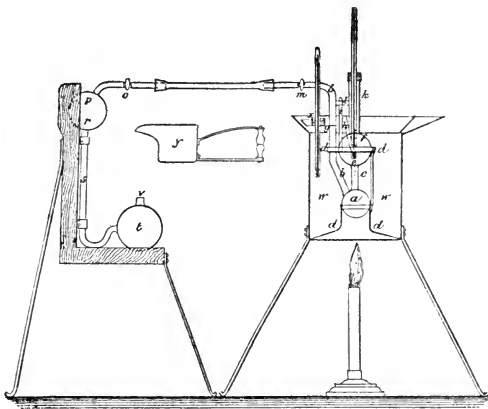

FIG. 264.—KÜNKLER SMALL-SAMPLE VISCOMETER.

temperatures to which they are exposed in practice, viz. 50° C. for machine-oil and 150° for cylinder-oil, with the employment of mercury as the exhaust liquid for temperatures below 100°, and water for higher ranges.

In conducting the test, the exhauster is filled from the lower globe, with the liquid employed, until the level of the mark, *p*, is reached, taking the *upper* meniscus in the case of mercury and the *lower* in the case of water. Care must be taken to leave but little of the liquid in the lower bulb, so as to avoid stopping the mouth of the tube, *s*, before it is emptied. The indiarubber tube is put into position, the viscometer placed in its stand, *d*; and a spring clip, *i*, slipped over the stay, *l*, both the taps, *o* and *m*, being kept shut. The viscometer and stand are finally placed in the bath. The liquid used for the bath is water for temperatures up to 100° C., an oil of high boiling-point being employed for higher temperatures. Such an oil should be used as gives off but little vapour at 150° C. To allow for expansion, the bath is scarcely filled up to the level at first, sufficient liquid being added, after warming, to cover the upper bulb of the instrument. The bath is maintained at the desired temperature by the aid of the lamp and a wooden stirrer. Before being placed in the viscometer, the

oil is warmed in a can, *y*, to several degrees above the testing temperature (53° for 50° and 165° for 150° C.). The apparatus is then lifted out of the bath for about half a minute to allow the *lower* bulb to cool, and the oil is poured in until the level of the filling-mark, *f*, is reached, the lower bulb being immersed simultaneously. (The object of this is to cause the expansion of the air in the cooled bulb by the heat of the bath, and so prevent the oil flowing through the capillary tube.) This position must be maintained until the oil is 4° higher than the testing temperature, when the viscometer is completely immersed, and allowed to stand until the right degree is reached, the bath liquid being continually stirred. At this point the taps, *o* and *m*, are opened in the order named, and the time occupied for the exhaustion of the oil up to the mark, *g*, is noted. If the oil under test is not clean and free from water, it must be filtered and dried at 110° C. The apparatus is cleaned with benzine and ether, and it must be carefully dried before it is again used. In fixing the standard by means of the glycerin solution, the lower bulb is immersed in warm water, as in applying the test to oil, to keep the glycerin out of the capillary tube.

**Comparison of Künkler's and Engler's Instruments.**—The table (CXLVI) shows the relation between results obtained with the Künkler and the Engler instruments, and an approximate idea can be obtained of the behaviour of a sample in Engler's viscometer when the sample itself is too small to be tested, by dividing the results obtained in Künkler's tester as compared with glycerin (not the rate of flow in seconds), by 1.50 for 20° C. ; 1.33 for 50° C. ; and 8.40 for 150° C.

TABLE CXLVI.—COMPARISON OF KÜNKLER AND ENGLER VISCOMETERS.

Oil.	Künkler's.						Engler's.					
	Viscosity.						Viscosity.					
	Rate of Flow in Seconds at			Compared with Glycerin Solution at 20° C. (1.110 sp. gr.) 66 Seconds=1.			Rate of Flow in Seconds at			Compared with Water at 20° C. 54 Seconds=1.		
	20°C.	50°C.	150°C.	20°C.	50°C.	150°C.	20°C.	50°C.	150°C.	20°C.	50°C.	150°C.
1. Refined rape oil, .	1220	380	...	18.48	5.76	...	660	224	...	12.22	4.15	...
2. Cod liver oil, .	760	262	...	11.51	3.97	...	430	165	...	7.96	3.06	...
3. Light American machine oil, 0.905,	905	215	...	13.71	3.26	...	475	140	...	8.80	2.59	...
4. Light Russian machine oil, 0.908,	4320	595	...	65.50	9.01	...	2340	355	...	43.33	6.57	...
5. Light American cylinder oil, . .	...	...	750	...	...	11.36	...	...	75	...	...	1.39
6. Dark American cylinder oil, . .	...	...	1005	...	...	15.23	...	...	95	...	...	1.76
7. Valvoline cylinder oil, . .	...	...	885	...	...	13.41	...	...	85	...	...	1.57

**Arvine's Viscometer.**—The Arvine viscometer, for testing cylinder-oils, consists of a coiled copper tube of small diameter, passing through a bath of boiling water. The lower end of the tube is provided with a small stop-

cock and jet, while the upper end communicates with a funnel which holds the oil.

**Barbey's Ixomètre.**—In this apparatus the oil flows through an annular space formed by fixing an iron rod 4 millimetres in diameter in the centre of a brass tube of 5 millimetres internal diameter. Increased resistance to the flow of the liquid is thus created, and the apparatus is said to be more sensitive than an ordinary jet viscometer.<sup>1</sup> The following is a free translation of the instructions given for conducting a test with this instrument :—

The steel rod is cleaned with fine linen and the interior of the apparatus with petroleum spirit, draining out the latter through the orifice made for that purpose at the bottom of the U-tube. The stoppers of the tube are replaced and the glass bulb filled with the oil to be tested. The bulb is fixed in the clamp provided for it, so that when the tap is slowly turned on the oil drops slowly into the funnel of the testing tube. By this means and by holding the apparatus at an angle the formation of bubbles in the testing tube is prevented. When the U-tube is filled oil will commence to flow out of the spout at the top of the smaller arm, and, when this occurs, the steel rod, which has previously been greased with the oil, is inserted slowly through the orifice provided for that purpose in the upper stopper of the U-tube until the point revolves on the bottom of the tube. The water-bath is then filled with water and brought to the required temperature by means of the gas jet or an alcohol lamp, and the whole apparatus maintained at that temperature for at least ten minutes.

The tap of the glass bulb is then turned on so that a fine thread of oil runs into the funnel. The head of liquid thus formed causes the oil to flow from the spout of the testing tube in a regular manner, and this action is continued for not less than ten minutes. The graduated glass tube supplied with the instrument is then moved on its support until the oil issuing from the spout falls into it, and a stop-watch is started directly the first drop of oil reaches the bottom of the tube. At the end of ten minutes the tube is removed from its position under the spout and the tap of the bulb turned off. The graduated tube is placed in the water-bath through a hole made for that purpose in the cover of the instrument, and allowed to remain there for five minutes. The number of divisions occupied by the oil in the tube is then read off and constitutes the "degree of fluidity" of the oil at the temperature of the experiment.

The following table is an approximate comparison between results given by the Redwood viscometer and the Barbey ixomètre :—

TABLE CXLVII.

Redwood. Time in Seconds.	Barbey. Degrees of Fluidity.
300	75
450	50
895	25

**Lepenau's "Leptometer."**—In this instrument<sup>2</sup> (fig. 265) there are two similar metallic cylinders placed side by side in a water-bath and terminating below in stop-cocks. Three sets of interchangeable jets are provided for attachment to the stop-cocks. A standard oil is placed in one cylinder and

<sup>1</sup> A detailed description of the instrument will be found in H. Delahaye's *Huiles Minérales* (Paris and Liège, 1911).

<sup>2</sup> German Patent, No. 23,662.

the oil to be tested in the other, and a pair of jets which will deliver the oils in drops at a suitable speed having been fitted to the stop-cocks, the oils are allowed to run out, and the number of drops falling from each cylinder, between two coincidences of dropping, is noted. The number of drops falling from the jet is not, however, necessarily a measure of the quantity of oil, since the size of the drop varies with the nature of the oil.

**Gibbs' Viscometer.**—The Gibbs viscometer, which is used on the Chicago, Milwaukee, and St. Paul Railroad, has been described in *Engineering Chemistry* by H. Joshua Phillips (2nd ed., 1894, pp. 244 and 245). The objects which the inventor is stated to have had in view in designing this apparatus are as follows:—

- (1) To have a large body of hot oil as a bath surrounding the oil to be tested, in order to keep the latter at a perfectly even temperature.
- (2) To apply a forced circulation to the bath by means of a double-action pump, to ensure equality of heat in all parts.
- (3) To deliver the oil to be tested at the orifice under a constant head.
- (4) To supply convenient means for accurately measuring the temperature of the oil.

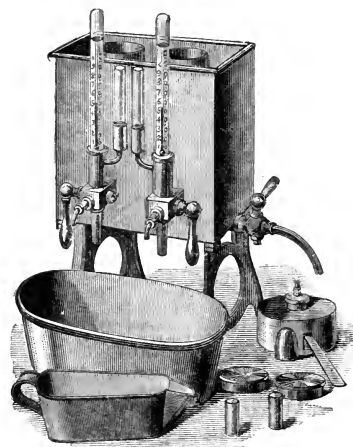

FIG. 265.—LEPENAU LEPTOMETER.

The oil-bath is of copper, with a heavy, brazed bottom. This contains a cylindrical inner chamber with a conical bottom terminating in a gauged aperture one-sixteenth of an inch in diameter. Into the inner chamber fits an inverted reservoir holding the oil to be tested. A tube extending nearly to the bottom of the inner chamber serves to determine the head of oil. Through this tube a thermometer is inserted. The bath is heated by means of a lamp placed beneath a heating chamber, which is in communication with the bath, and with a small double-action force-pump. Circulation of the oil in the bath is promoted by the use of suitably placed deflector-plates.

**Bubble System.**—One method of ascertaining the viscosity of oils, which has been proposed, is to note the time occupied in the ascent of a bubble of air through a given column of the oil. Professor Mills has modified the system by using hollow glass spheres, but without obtaining promising results.

**Viscometers of Napier and Cockrell.**—The paddle viscometers of Napier and of Cockrell are based upon the principle of taking the speed of a paddle-wheel revolving in the oil as a measure of the viscosity. Mr. Napier has also employed a series of concentric rings attached to a revolving plate, A (figs. 266 and 267), and working in the spaces, C, between similar rings, B, on a fixed plate. The revolving gear is supported on an upright, D, and a jacket, E, encloses the oil-vessel. Napier has, in another arrangement, employed a hollow vertical drum revolving in a slightly larger cylinder containing the oil.

**Doolittle's Viscometer.**—Another device is the *torsion* viscometer proposed by Doolittle.<sup>1</sup>

In this apparatus, as shown in fig. 268, a steel wire, supported by a frame, is attached to the upper end of a rod fixed vertically in the centre of a graduated horizontal disc, by means of which the torsion sustained by the wire is measured. To the lower end of the rod a cylinder, 2 inches long and  $1\frac{1}{2}$  inch in diameter, is attached by a stem. The cylinder being immersed in the oil to be tested, the disc is adjusted to register exactly zero, showing that there is no torsion on the

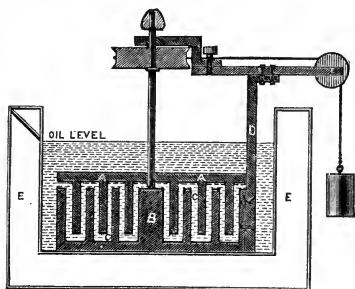

FIG. 266.

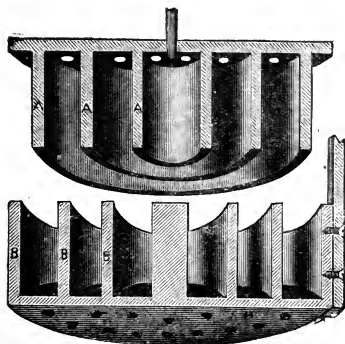

FIG. 267.—  
NAPIER VISCOMETER.

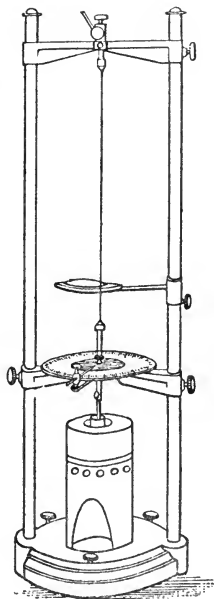

FIG. 268.—DOOLITTLE VISCOMETER.

wire, and is then supported in that position while the oil is brought to the temperature required for the test. When this temperature is attained, the milled head at the upper end of the wire is rotated through  $360^\circ$ , and the disc being released from its supports, is drawn round by the torsion of the wire. If there were no resistance, the disc would revolve back to zero, and the momentum would carry it  $360^\circ$  in the opposite direction; but the resistance offered by the oil to the rotation of the cylinder, which resistance is directly proportional to the viscosity of the oil, prevents this complete revolution, and the simplest

<sup>1</sup> *Journ. Amer. Chem. Soc.*, xv, 173 (1893); and *Journ. Soc. Chem. Ind.*, 709 (1893).

way of expressing the viscosity is by the number of degrees of retardation between the first and second complete arcs described by the disc.

A circular issued by the maker of the instrument contains the following additional particulars:—

“For example, suppose we twist the wire 360° and release the disc so that rotation begins. In order to obtain an absolute reading to start from, which shall be independent of any slight error in adjustment, we ignore the fact that we have started from 360°, and take as our first reading the end of the first swing. Ignore the next reading, which is on the other side of the 0 point, as it belongs in common to both arcs. Take the third reading, which will be at the end of the second complete arc, and on the same side of the 0 point as the first reading. The difference between these two readings will be the number of degrees of retardation caused by the viscosity of the oil. Suppose the readings are as follows:—

First reading, right hand, . . . . .	355.6°
Second „ left hand, ignore.	
Third „ right hand, . . . . .	338.2°
	17.4° retardation.

“In order to secure freedom from error, we make two tests—one by rotating the milled head to the right, and the other to the left. If the instrument is in exact adjustment, these two results will be the same; but if it is slightly out, the mean of the two readings will be the correct reading. In order to overcome the variations in different instruments, each one is standardised against pure cane-sugar solutions, after the manner proposed by Mr. Babcock, and the viscosity is expressed in the number of grams of pure cane-sugar contained in 100 c.c. of the syrup at 60° F., which will give the retardation designated at 80° F. These readings are obtained by making a number of solutions containing known amounts of pure cane-sugar and determining the retardation of each. A curve is then mapped out on a piece of blotting-paper, the number of grams of sugar in 100 c.c. of the different syrups representing the abscissæ, and the degrees of retardation, the ordinates. This curve enables us to interpolate the value of each degree of retardation in terms of pure cane-sugar, and in this way a table of viscosities is drawn up and furnished with each instrument. This table renders the results obtained by different instruments strictly comparable.”

**The Value of the Viscosity Test.—Friction-testing Machines.**—In the instruments already described, no attempt is made to reproduce the conditions under which lubricating oils are employed, and the results which they furnish are of a purely arbitrary character. Nevertheless the author is of opinion that the viscosity of a mineral lubricating oil is the best guide to its lubricating value, the consumer being thus enabled to select, from time to time, oils similar to those which he has found by practical experience to give the most satisfactory results. The subject of the comparative value of results obtained with a viscometer and with a friction-testing machine has been discussed by the author in a paper read before the Society of Chemical Industry,<sup>1</sup> from which the following remarks are substantially reproduced:—

In order fully to realise the importance of the determination of viscosity in mineral lubricating oils, and the value of a good test of viscosity, it will be necessary briefly to consider the laws of the friction of fluids, as applicable to the circumstances in which oils are employed in the lubrication of machinery.

<sup>1</sup> *Journ. Soc. Chem. Ind.*, v, 121 (1886).

These laws, as is well known, differ very materially from those which govern the friction of solids, though it is important to bear in mind that the friction in the case of the lubricated rubbing-surfaces of machinery in motion is usually a compound friction made up of the friction of solids, and of the friction of fluids, in proportions varying according to the circumstances of the case.

The friction of solids in motion is of two kinds—viz. sliding friction and rolling friction. It is, however, only the former class of solid friction which now demands our attention. In sliding friction the magnitude of the resistance is, up to the point of abrasion, dependent upon the character of the surfaces, and proportional to the force with which they are pressed together, though in the case of lubricated surfaces the resistance may be principally due to the adhesion when the pressure is very low. In fluid friction, on the other hand, whether of liquids or gases, the resistance is proportional to the area and velocity of the surface exhibiting it, and to the density and viscosity of the fluid. As Professor Thurston<sup>1</sup> expresses it:—"Fluid friction is therefore the friction of adjacent bodies of fluid in relative motion, and is due to the formation of small whirls or large eddies in the two bodies, the production of which absorbs energy from the flowing mass. The friction of the fluid finally extinguishes this energy of eddy-motion, converting it into heat, and raising the temperature of the mass by the introduction of the heat-equivalent of the mechanical energy thus destroyed. The resisting property which thus effects this conversion, and which is the cause of fluid friction, is termed viscosity. . . . In the case of limpid liquids and gases the resistance is of kinetic character, rather than one due to intra-molecular action; but the flow of viscous liquids is evidently greatly influenced by their molecular constitution."

In most cases, as already stated, the friction of the lubricated surfaces of machinery is a compound one, but in some instances it is found practicable to float the moving part in the lubricant, and, in such circumstances, the resistance is due only to fluid friction. On the other hand, in the case of slowly-moving heavy machinery, the resistance is usually largely made up by the friction of solids. It follows from what has been said that in theoretically perfect lubrication the resistance would be independent of the pressure, and the nearer we can approach to this condition in practice, the better.

The more viscous the lubricant and the stronger the attraction taking and holding it between the moving surfaces, the greater the pressure which can be sustained; but unnecessarily high viscosity creates unnecessary fluid friction, and the viscosity of the lubricant should therefore be in proportion to the pressure. In other words, the lubricant should have only just sufficient viscosity to keep the moving surfaces apart, under the maximum pressure. The amount of viscosity required in a lubricant, therefore, varies according to the circumstances in which the lubricant is to be used. It is obviously dependent not only upon the load carried upon a given area, but also upon the fit of the bearing-surfaces, and upon the character of the motion. Thus, the axles of railway trucks are subjected to pressures greatly in excess of the load carried, when the vehicle is passing over inequalities in the permanent way. It has also been found that the power required to drive machinery which has been lubricated with an oil sufficiently viscous to keep the moving surfaces apart, is diminished when a more fluid lubricant is substituted.<sup>2</sup> It is true that this diminution of resistance is accompanied with greater wear

<sup>1</sup> *A Treatise on Friction and Lost Work in Machinery and Millwork.* By Robert H. Thurston, M.A., C.E., New York, 1885.

<sup>2</sup> It has been well said that many an engineer wastes tons of coal in an attempt to save gallons of oil.

of the metallic surfaces, and greater expenditure of the lubricant, but in the case of factories provided with barely sufficient motive power, it may be preferable to have less theoretically perfect lubrication.<sup>1</sup> In a cotton mill, for instance, the use on the spindles, of a very slightly better, in the sense of a more viscous, lubricant, though increasing the fluid friction between the bearing-surfaces of each spindle only to an infinitesimal extent, might arrest the motion of the whole machinery of the mill. Largely for these reasons, no doubt, the many ingenious machines of Ingram and Stapfer, Thurston, Woodbury, and others, designed to test the lubricating value of oils, have not hitherto given results of much practical value. With some of these machines strictly comparative data of lubricating power under the conditions present in the machine can be obtained; but as these conditions frequently differ from those presented in actual practice, the deductions drawn from the data may be misleading.

Professor Thurston himself admits that the use of the testing machine to determine the relative friction-reducing power and wear, and the endurance of oils, as data for use in the solution of the commercial problem, will often be found to involve some difficulties. These difficulties arise, however, not from faults of the method, but, as he says, from the exceedingly great uncertainty often existing as to whether the conditions of test are precisely those of use. He adds that a good testing-machine may be relied upon, if properly handled, to give accurate data; but it can rarely be made equally certain that the same conditions can be permanently retained when the lubricant is put in service. Satisfactory approximations may, however, in his opinion, readily be secured, with careful supervision and ordinary skill, for all cases in which the machinery is well proportioned, in good order, and well cared for. Professor Thurston further remarks that experiments made upon the nicely-fitted journal of a testing machine are not conclusive as to suitability of a lubricant for use on a similar journal which is not well fitted. The latter, bearing only in spots, or along lines of contact, is subjected, on such surfaces of contact, to pressure which may be enormously greater than that affecting the same journal when wear or refitting has given it a good fitting, and the best lubricant is therefore one adapted to such intense pressure. Could the magnitude of this extraordinary pressure be known, a good testing-machine would determine which of any collection of oils is best fitted to sustain it. The testing-machine determines the behaviour of oils upon its own journals; if those on which the lubricant is to be used are similar, its behaviour will then be the same. While the machine does not usually serve to select oils for badly made surfaces, it exhibits the intrinsic qualities of the oils tested; and every mechanic and engineer endeavours to get all journals into as good condition as those of the testing machine, and thus fit them to do good work with good oils. Professor Thurston also expresses the opinion that in order to determine precisely what oils are adapted to any special purpose, or to ascertain for what use any oil is best fitted, it is necessary to make an examination of the lubricant while it is working under the specified conditions. That is to say, the oil should be put upon a journal of the character of that on which it is proposed to use it, subjecting it to the pressure proposed, and running

<sup>1</sup> Professor Thurston points out that the measure of the coefficient of friction alone is not always a gauge of the value of an oil. A low coefficient is sometimes found to co-exist with serious wear, and even low friction and a cool journal may be accompanied by wear. With very light pressures and high speeds, as with fast-running spindles, light mineral oils sometimes give low friction, and yet produce rapid wear. Mr. F. W. Arvine found that a cotton spindle, after running for some time at a speed of 6500 revolutions per minute with a fluid oil, lost as much as one-tenth gram in weight.



it at the speed that the journal is expected to attain; its behaviour will then show conclusively its adaptability to such an application. Valuable papers on the subject of the mechanical testing of lubricating oils have been published by Professor Ordway<sup>1</sup> and Mr. C. J. H. Woodbury.<sup>2</sup> The experiments conducted by Professor Ordway, in association with Mr. Atkinson, had for their object to determine, among other points, the extent to which spindle-oils in common use were liable to spontaneous combustion when absorbed by cotton-waste or other similar material, as well as the temperature at which they evolved inflammable vapour. But the investigation is referred to here, chiefly because these gentlemen report that three machines—two American and one English—which they had obtained with the view of testing the lubricating power of the oils under examination, furnished no satisfactory results; and it was accordingly found necessary to substitute for these machines an ordinary spinning-frame, with a thermometer applied to each spindle, the heat evolved being regarded as a measure of the friction. Mr. Woodbury's papers are largely devoted to a description of the results obtained with the well-known testing-machine of which he is the inventor. In the first paper it was pointed out that friction varies with the area, because the adhesiveness of the lubricant is proportional to the area, and the resistance due to this cause is a larger fraction of the total mechanical effect with light, than with heavy pressures. Accordingly, as the results of the preliminary experiments indicated that the coefficient of friction varied with the conditions, it was found necessary to reproduce those of actual working, in order to determine the value of a lubricant for specific purposes.<sup>3</sup> In Mr. Woodbury's second paper, the results obtained with a modified form of apparatus, constructed to carry pressures up to 40 lbs. per square inch, were given. The experimental data contributed by Mr. Woodbury, supplemented by those reported by Mr. Beauchamp Tower in this country, constitute a comprehensive series, since Mr. Tower operated at great pressures (100 lbs. to 625 lbs. per square inch), though with a special method of lubrication (the oil-bath system); but in the discussion which followed the reading of Mr. Woodbury's second contribution, it was pointed out by Mr. F. W. Arvine, chemist of the Thompson & Bedford Company of New York (manufacturers of lubricating oils), that the agreement between the results yielded by ordinary testing-machines and those obtained in actual practice was unfortunately very small.<sup>4</sup>

As the Pennsylvania Railway Company have paid considerable attention to the testing of lubricating oils, it is instructive to find that in 1885 the opinion

<sup>1</sup> Report by Prof. J. M. Ordway, representing the department of Industrial Chemistry of the Massachusetts Institute of Technology, and Edward Atkinson, representing sundry insurance companies, *Proceedings of the Semi-annual Meeting of the New England Cotton Manufacturers' Association*, held at Boston, U.S.A., 30th October 1878.

<sup>2</sup> "Measurements of Friction of Lubricating Oils," by C. J. H. Woodbury, *Factory-Inspector to Mutual Assurance Companies, Trans. Amer. Soc. Mech. Eng.*, vol. i, pp. 73-118 (1880); vol. vi, pp. 136, 137 (1885).

<sup>3</sup> The working pressure in Mr. Woodbury's earlier experiments was 5 lbs. per square inch, and the speed 500 revolutions per minute, these conditions corresponding with the velocity and pressure of a Sawyer spindle running at 7600 revolutions per minute, with a band tension of 4 lbs. Mr. Woodbury stated that the intermittent pressure on the wrist-pin of a locomotive amounted to as much as 3000 lbs. per square inch. According to Professor Thurston, the maximum pressure on the crank-pins of heavy engines is 1200 lbs. per square inch, and under the pivots of drawbridges sometimes as much as 9000 lbs. per square inch.

<sup>4</sup> Mr. Arvine found it necessary to use for the testing of spindle-oils a frame of spindles, such as may be found in a cotton mill, and for the testing of heavier oils a railway-wagon axle, of the usual construction, capable of being loaded with the weight commonly carried. Both pieces of apparatus were driven at the ordinary speed, and were fitted with sensitive dynamometers and thermometers.

of Dr. Charles B. Dudley, chemist of the company, who had studied the subject of lubricants during the preceding ten years, was that the problem of diminishing the loss due to friction was complicated, and not well understood. The author has not had the opportunity of working with the machine of Professor Thurston or that of Mr. Woodbury, but some years ago he was engaged for many months in testing lubricating oils with the Ingram and Stapfer machine (see p. 851), and he found it impossible to obtain any results that were thoroughly satisfactory from a practical point of view.

In studying the records of the experiments made in the testing of lubricating oils with the various machines which have been devised for the purpose, one cannot fail to admire the ingenuity and patience with which the results have been arrived at. It must, however, be obvious that the indications afforded by testing-machines may in the present state of our knowledge of the subject be wholly misleading, and it is this fact which has led the author to attach great importance to the adoption of a good system of determining the viscosities of oils. To his mind, indeed, the most valuable result of the experiments made with testing-machines has been the demonstration of the close relation which exists between the viscosity and the lubricating power of mineral oils. Professor Thurston has pointed out that this close relation is well shown in the curves, which exhibit graphically the results obtained by Mr. Waite.<sup>1</sup>

Mr. Woodbury states that, within a close approximation, the lubricating qualities of an oil are inversely proportional to its viscosity—that is, that the friction decreases with the cohesion between the particles of oil. Although in succeeding remarks Mr. Woodbury somewhat qualifies the statement quoted, there is little doubt that the determination of the viscosity of an oil affords the most valuable test of lubricating properties that we have at our disposal. There may be an advantage in testing the oil by using it under conditions to which it will be subjected in actual practice, but it is admittedly exceedingly difficult to determine what these conditions are, especially in some cases, and still more difficult to reproduce them with certainty. On the other hand, if a certain oil has given satisfactory results under given conditions of fit, or want of fit, of bearings, pressure, speed, and temperature, it may be predicted with tolerable certainty that another oil of the same nature, having a similar viscosity, will yield equally good results.

Professor Thurston, who has devoted much study to mechanical methods of testing, gives<sup>2</sup> the following as the characteristics of an efficient lubricant:—

- (1) Enough “body” or combined capillarity and viscosity to keep the surfaces, between which it is interposed, from coming in contact under maximum pressure.
- (2) The greatest fluidity consistent with the preceding requirement—*i.e.* the least fluid friction allowable.
- (3) The lowest possible coefficient of friction under the conditions of actual use—*i.e.* the sum of the two components, solid and fluid friction, should be a minimum.
- (4) A maximum capacity for receiving, storing, transmitting, and carrying away heat.
- (5) Freedom from tendency to decompose or to change in composition by gumming, or otherwise, on exposure to the air, or while in use.
- (6) Entire absence of acid or other properties liable to produce injury of materials or metals with which they may be brought in contact.

<sup>1</sup> *Proceedings of the New England Cotton Manufacturers' Association*, 1880.

<sup>2</sup> *A Treatise on Friction and Lost Work in Machinery and Millwork*, New York, 1885.

- (7) A high temperature of vaporisation, and a low temperature of solidification.
- (8) Special adaptation to the conditions as to speed and pressure of rubbing surfaces, under which the unguent is to be used.
- (9) Freedom from grit and from all foreign matter.

Valuable information on the testing of lubricating oils will be found in *Lubrication and Lubricants*, by Leonard Archbutt and R. Mountford Deeley, 3rd ed., 1912.

**MacNaught's Tester.**—The MacNaught tester was invented about 1838,<sup>1</sup> and is shown in fig. 269. It consists of a circular plate, E, on a spindle, A, capable of being revolved by an endless cord running on a pulley, D. On the plate E rests a plate F, having a stud, a, which, when the plate is turned, engages with a pin on an arm attached to a weighted lever, G H. The instrument is fixed to a table by means of the clamp, B C. A few drops of the oil are placed on the plate E, and the apparatus is then set in motion at the proper speed. The plate F thus tends to revolve, and through the stud, a, to alter the position of the lever, G H, but this is prevented by moving the adjustable weight, J. The extent to which the weight is moved in establishing equilibrium is a measure of the viscosity of the oil, and hence this instrument in its original form might more properly be described as a viscometer.

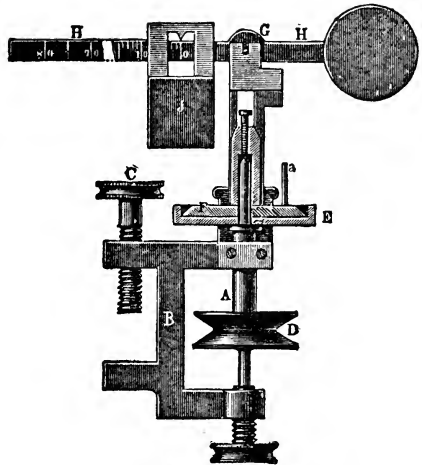

FIG. 269.—MACNAUGHT LUBRICANT TESTER.

**Duske's Modification.** — Duske<sup>2</sup> has introduced a modification in which adjustable pressure is applied to the plate, F, by means of a lever and sliding weight.

**Woodbury's Tester.**—In the tester introduced by Woodbury,<sup>3</sup> which has been described as a modification of MacNaught's, the load is applied by direct weights. The upper plate is surmounted by a hollow chamber divided into channels through which a current of water circulates, and is further covered with an ebonite hood, lined with eiderdown to prevent access of heat from the outside. Four upright pillars on the upper plate carry, by a ball and socket joint, an axle moving in two bearings and supporting a crossbeam which bears the load. The weights are under the table on which the machine stands, on a platform suspended by stirrups from the crossbeam. In order to equally adjust the wearing-surfaces of the two discs, the axes of the upper and lower spindles do not coincide, but are on parallel lines about one-eighth inch apart. A thermometer indicates the temperature in the upper disc, and the rate of

<sup>1</sup> *Mechanics' Magazine*, 1838, No. 774; and *Dingler's polytechn. Journ.*, clxiv, 18 (1862).

<sup>2</sup> *Dingler's polytechn. Journ.*, clxiv, 19 (1862).

<sup>3</sup> *Engineering*, xxxviii, 532 (1884).

feed of the oil under test is observed by using a glass feed-tube. To minimise torsional friction in the upper axle, the bearings are movable, and are revolved in opposite directions. A counter records the number of revolutions, and a dynamometer registers the amount of friction. In cases where the friction would be too great for the dynamometer, a pair of compound levers is employed to reduce the stress to one-fifth the actual friction, and in such cases, the reading of the dynamometer must be multiplied by five.

**Deprez and Napoli's Tester.**—The apparatus of Deprez and Napoli<sup>1</sup> was patented in France in 1877. It consists of a horizontal flat polished disc, A (fig. 270), mounted on an axle set in motion by bevel cog-wheels driven by a

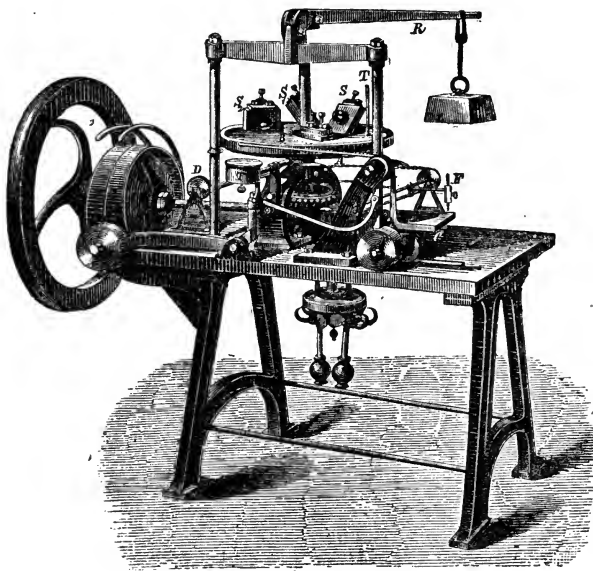

FIG. 270.—DEPREZ-NAPOLI TESTER.

pulley, D, and carrying a second disc, B, by means of three bronze blocks, S, S<sub>1</sub>, and S<sub>2</sub>, inclined towards A at an angle of 30°, and having a contact-surface of 10 square centimetres each, so that the pressure exerted on B by a weighted lever, R, is equally divided among them. The friction between A and S, S<sub>1</sub>, S<sub>2</sub>, tends to rotate B, the tendency varying inversely with the lubricating power of the oil under test. To the edge of B is attached one end of a steel ribbon, the other end being fastened to a pivoting pulley. To this pulley is attached a vertical pendulum, P, which is raised towards the horizontal by the rotation of B. The movement of P causes a reciprocating motion of a small wheeled trolley, C, through the medium of a pin and slot. The trolley carries a piece of paper, on which a curve showing the movement is marked by a pencil, F, fixed to a travelling arm. The speed of this arm is governed by the number of

<sup>1</sup> *Dingler's polytechn. Journ.*, ccxxvi, 30 (1877).

revolutions of the principal axis—*i.e.* of the plate A. The curves show the degree of friction at the rate of speed adopted, and, if quadrated, will give the total energy absorbed by the machine. To save the trouble of calculating out the results of the diagrams, the inventors have affixed to the machine a totaliser, consisting of a roller, T, kept in position against the edge of a disc concentric with A, by means of a spring. Its axle is capable of any degree of inclination in a fixed vertical plane, and is so connected with the pendulum, P, as to make with the horizontal, the same angle as is made by the pendulum with the vertical. The number of revolutions of the roller as recorded by the totaliser, is proportional to the force, in kilograms, of the friction between the two plates. Five grams of oil are used for each test, and to ensure the regularity of speed necessary for the exact comparison of the lubricating properties of different samples, a speed-governor is fixed below the apparatus.

**Bailey's Tester.**—In Bailey's pendulum tester (fig. 271), designed for testing oils which are to be used for clocks and watches or other light work, a single drop of the oil is placed on a small disc of brass linked to a pendulum as shown, and resting on a disc. The pendulum is set in oscillation over a graduated arc, and the viscosity is measured by the time which is occupied in its coming to rest.

**Thurston's Tester.**—Among the mechanical testers aiming at the examination of the oil under conditions closely approximating to those in actual practice, the inventions of Professor R. H. Thurston are of particular importance.<sup>1</sup> Figs. 272 and 273 show one form of the Thurston tester. The lubricant is placed on a journal, F, carried on the extremity of a shaft, A, sustained by journals, B, on a stand, D E, and driven by a pulley, C. The shaft is driven at a speed corresponding with the work which the lubricant is to do, and has a counter at the end to indicate the number of revolutions. The journal, F, is grasped by bronze bearings, G G', pressed together by a spring, adjusted by a screw, K K', and having its pressure indicated on a scale by a pointer, M. A thermometer, Q, indicates the heat produced during the test. The brasses and spring are carried by a pendulum, H, weighted at I, so that the maximum friction of the *dry* smooth bearing will swing it into a horizontal position. The pendulum carries a pointer, O, traversing an arc, P, which is so graduated, that by dividing the reading by the pressure indicated by the pointer, M, the co-

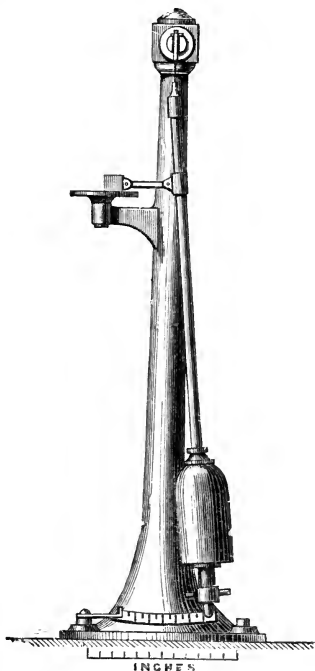

FIG. 271.—BAILEY TESTER.

<sup>1</sup> See Thurston's *Treatise on Friction and Lost Work in Machinery and Millwork*, New York, 1885; and a paper read by Mr. W. H. Bailey before the Manchester Association of Employers, Foremen, and Draughtsmen, Manchester, 1878.

efficient of friction when the lubricant is placed on the bearing, F, may be found. In Professor Thurston's treatise, the theory of the working of this machine is fully discussed. The journal is cleansed, after each test, with alcohol, gasoline, or benzine, but the effect of the lubricant is often felt in succeeding tests, long after starting with a new lubricant. Steam-cylinder lubricants may be tested by heating the bearing to the proper temperature. Owing to the good work done by his first machine, Professor Thurston devised a modification especially adapted for railway work, and fig. 274 shows the "New Zealand Railways" pattern of his *recording* tester, manufactured by Messrs. W. H. Bailey & Co., of Salford. In principle the machine resembles that described above. The shaft has three different sizes of pulleys for driving it, and the brasses are cast hollow, as first proposed by G. A. Hirn, so that water may be passed through

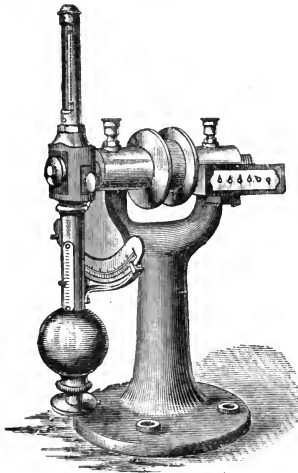

FIG. 272.

THURSTON TESTER.

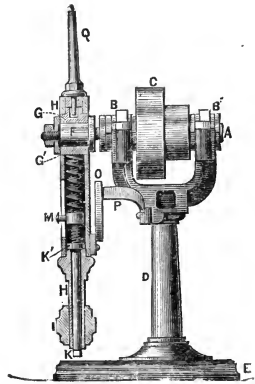

FIG. 273.

them to keep the bearing at a uniform temperature. The oil is fed to the journal by means of oil-cups, and a key and nut are provided for instantly relieving the journal of the pressure of the helical spring. The automatic recorder is an improvement due to Lux. The pendulum has an arm which raises and depresses a slide carrying a pencil. The pencil bears against a cylinder carrying a sheet of paper ruled in squares, and revolving once for each 100,000 revolutions of the journal. The diagram is thus drawn to a scale of five-sixteenths of an inch for every 1000 revolutions.

**French Tester.**—The friction tester employed by the Paris, Lyons, and Mediterranean Railway Company (figs. 275 and 276), exhibited in 1878, has the advantage of subjecting the oils, under test to conditions similar to those under which they are employed on the railway, and indicates the behaviour of the oil under the varying speeds of an ordinary pair of railway wheels, as to resistance, rate of consumption, and rise of temperature in the grease-boxes. On a firm foundation of masonry is erected an iron frame, A A, in which is mounted a driving-axle, B, carrying a pair of wheels, C C, at the usual rail-

distance apart. An ordinary pair of truck-wheels, D D, rests on these, the ends of the axle, E, running in bearings fitted with grease-boxes of the usual type. The box-castings carry a spring, and terminate at the top in a screw, *p*. The springs can be loaded to any required degree by weights, F, suspended from lever arms, *o o*, bearing on perpendicular rods carried down from the extremities of the springs. The wheels, D D, can be raised or lowered at will by means of screws cut on a cross-bar, *s*, worked by a hand-wheel, *q*, and acting on the screws, *p p*. The driving-axle carries in addition a drum, G, by means of which motion is imparted to the apparatus, and is fitted with an indicator for recording the number of revolutions. The rate of speed, in kilometres per hour, is shown on a scale, *v*, by means of a pointer, *t*. In order to reproduce still more closely working conditions, the driving-wheels, C C, are mounted eccentrically  $2\frac{1}{2}$  mm. (one-eighth of an inch) out of truth, thus producing an equivalent to the vibration of a railway truck. In applying the test, the oil is put into the grease-boxes (previously well cleaned), and the upper wheels are raised by the screws clear of the driving-wheels, which are then put in motion. The upper wheels are then gradually lowered, and the requisite load of weights applied. The oil which produces the least rise of temperature in the axle-boxes under the greatest load and highest rate of speed, is considered the best.

#### Ingram and Stapfer's Tester.—

In the Ingram and Stapfer tester (fig. 277), a definite quantity of the oil, measured from a bottle or tube, or by drops, is placed on the bearing, the pressure on which is produced in the manner shown in the figure, and the shaft is driven at about 1500 revolutions per minute. When the temperature produced by the friction has reached  $200^{\circ}$  F., as indicated by the thermometer, the machine is stopped and the total number of revolutions since the commencement of the test is read off from the counter, the value of the lubricant being gauged from this result.

**Boult's Tester.**—Figs. 278 and 279 represent Boult's cylinder-lubricant tester, used for oils required for the cylinders of steam, gas, and hot-air engines, steam-hammers, etc. The enlarging friction-journal, D, is expanded by a

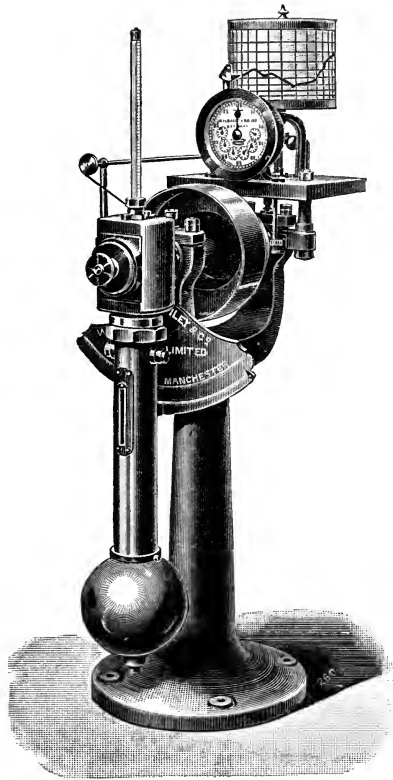

FIG. 274.—THURSTON RECORDING TESTER.

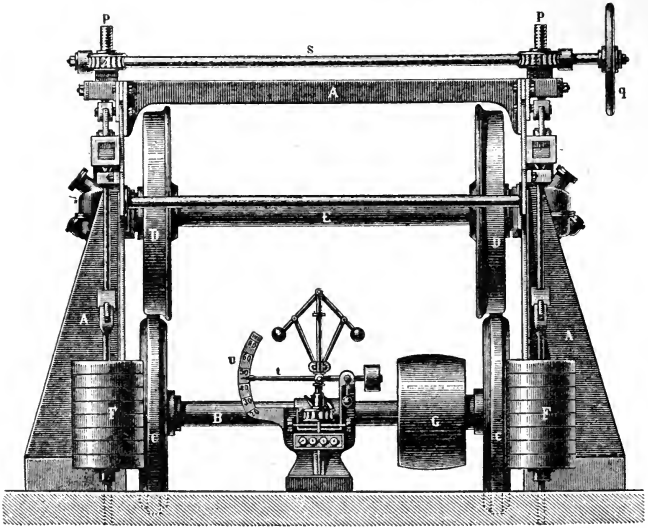

FIG. 275.

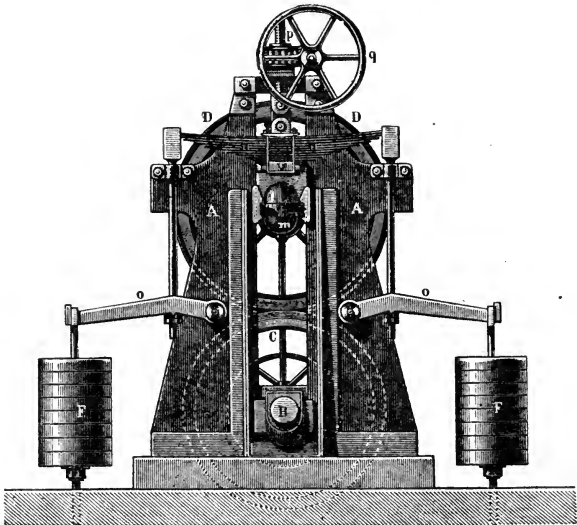

FIG. 276.  
FRENCH LUBRICANT TESTER.



spiral spring, E, adjusted by screws, B, and the friction-surfaces to which the oil to be tested is applied, are heated by a cylindrical hot-oil bath, C, to which the necessary temperature, as indicated by a thermometer, A, is imparted by a Bunsen burner, F. The tester is run at about 500 or 600 revolutions per minute, or, for high-speed engines, at as much as 1000. It may be used for temperatures as high as 450° F. or, by cooling the oil-bath with ice, etc., may be employed for testing the value of lubricants at low temperatures.

**Cold Test.**—Lubricating oils are subjected to what is known as the cold test, with a view to ascertaining their power of withstanding low temperatures without solidifying, or depositing paraffin, and the method of applying the test varies with the description of the oil, and, to some extent, with the interpretation of the term by the operator. The cold test of pale oils is usually considered to be the point at which, on a gradual reduction of temperature,

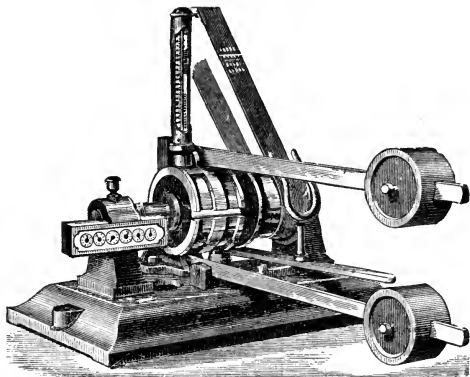

FIG. 277.—INGRAM-STAFFIER TESTER.

the initial separation of solid hydrocarbons occurs. The test is applied in the author's laboratory in the following manner:—

A beaker about 3 inches in height, and 1½ inch in diameter, is filled to a depth of 1 inch with the oil to be tested. The oil is slowly cooled, and from time to time is gently stirred with a thermometer until the first indication of the separation of paraffin is observed. This indication, which is recorded as the "cloud-test," often takes the form of a cloudy stream following the thermometer as the latter is slowly moved. When the separation of solids is well defined, a test may be applied to a column of the oil an inch and a half in depth in a test tube about an inch in diameter. The tube is plunged in a bath of iced water, or ice and salt, until a thin layer of paraffin congeals on the sides. During the cooling, the oil is stirred with a thermometer, and when congelation commences, the tube is wiped and held in front of a window with constant stirring, with the thermometer, until the solid has redissolved. The temperature is then noted, and the operation is repeated twice. If the last two tests agree, the temperature may be taken as the cold test. As some of the more viscous oils contain solid hydrocarbons which resemble vaseline rather than crystalline paraffin, the point at which separation of solids commences is not easily observed, and it is then better to determine the point at which the oil becomes semi-solid, or ceases to flow on inclining the containing vessel. In black oils, the commencement of

the separation cannot be seen, and the temperature at which such oils cease to flow is, therefore, taken as the cold test.

The melting-point of oils which are solid at ordinary temperatures is often taken in the following manner:—A thermometer has its bulb coated with the oil, and is suspended in a beaker of water which is very slowly warmed, the temperature at which the oil, which is of lower specific gravity than the water, begins to flow upwards being noted as the melting-point. This method does not, however, give satisfactory results with oils that are not fairly homo-

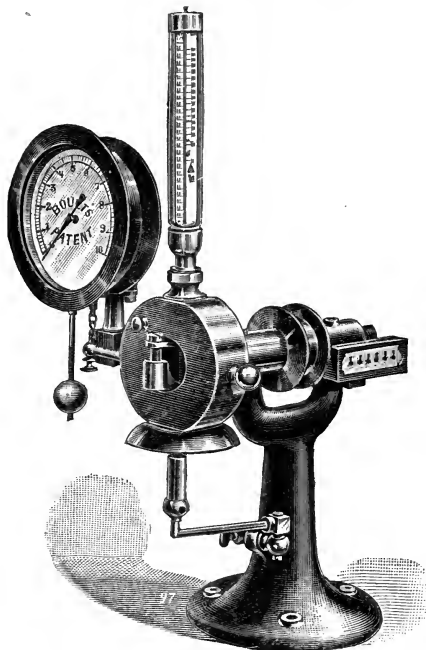

FIG. 278.

BOULT LUBRICANT TESTER.

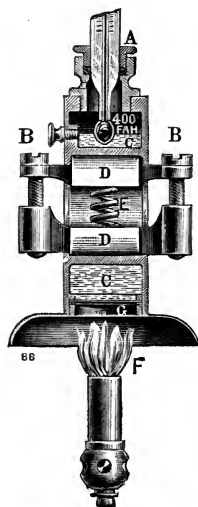

FIG. 279.

geneous in composition, and, according to the author's experience, a better one is that suggested by Bensemam<sup>1</sup> for determining the point of fusion of fatty acids. This consists in placing a drop of the fused oil in the wide portion of a drawn-out tube, and allowing it to become quite solid; then suspending the tube vertically in a beaker of cold water by the side of a delicate thermometer, and applying heat very gradually until the oil begins to flow down the side of the tube into the constricted portion. The temperatures are noted at which (a) the oil begins to flow, and (b) enters the constricted part. The first is termed the initial point of fusion, and the second the final point of fusion.

<sup>1</sup> *Rep. Anal. Chem.*, ii, 165; *Journ. Soc. Chem. Ind.*, iv, 535 (1885); also Cameron's *Oils and Varnishes*, 214.

The author finds that this method gives closely concordant results, and that the difference between the two points is about  $2^{\circ}$  F.

According to the rules of the New York Produce Exchange, the cold test is determined by cooling the oil in a glass vessel, 4 inches deep and 3 inches in diameter, in a refrigerator. A thermometer is placed in the centre of the oil and another in the refrigerator, and, if the oil is still liquid when the thermometers both record a specified temperature, the cold test is considered satisfactory.

**Tagliabue's Cold-Test Apparatus.**—In Tagliabue's cold-test apparatus (fig. 280) the oil-cup is contained in a chamber, F, surrounded by an ice-chamber, C, with a non-conducting jacket, A. Taps, J, are provided for forcing in warm air when it is desired to raise the temperature of the oil. The oil-cup is fitted on a rocking shaft so that the oil may be kept in motion, and the front of the apparatus has a glass window through which the progress of the test may be observed, and the temperature of the oil, as indicated by a thermometer, *d*, noted. Two other thermometers, *d*, are placed in the refrigerator.

**Schultze's Cold-Test Apparatus.**—

The cold-test apparatus of Schultze, of Berlin, adopted by the Prussian State Railways,<sup>1</sup> is fitted with a U-tube 6 mm. in diameter, and graduated in millimetres, to contain the oil to be tested. The U-tube is immersed in a freezing mixture, and is connected with a manometer, by means of which, on opening a pinch-cock, a pressure equal to a height of 50 mm. of water may be applied to its contents. The temperature of the freezing mixture is indicated by a thermometer, and may be adjusted as required by varying the constituents of the mixture. In applying the test, the U-tube, charged with the oil to a height of 30 mm. in each limb, is immersed in the freezing mixture for an hour, after which it is raised so that the oil-surface is above the refrigerant. The pressure from the manometer is then allowed to act, and the rate at which the oil is depressed in the limb connected with the manometer, during one minute, is noted. Several U-tubes containing samples of oil may be cooled simultaneously, and tested one after the other. Dr. Albrecht considers this apparatus unsuited for practical use, and is of opinion that sufficiently accurate results were obtained by the old test used on the Prussian State railways, which consisted in noting whether the oil at a given temperature, and under a pressure of 30 mm., issued in drops from the 5-mm. nozzle of the test apparatus.

**"Demulsification Value" of Turbine Lubricating Oils.**—An apparatus for determining the degree to which a lubricating oil will resist demulsification on being very intimately mixed with water is illustrated and described in a recent paper by Mr. Arnold Philip,<sup>2</sup> the result being termed by him the "demulsification value."

The Demulsification tester (fig. 281) consists of a jacketed cylindrical vessel, supported on a tripod stand, and fitted with a movable cover carrying a mechanical stirring device. The jacket contains distilled water which can be

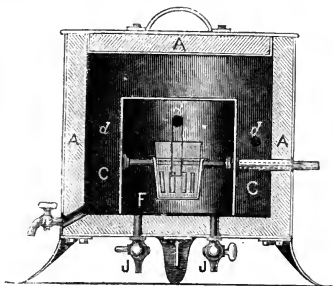

FIG. 280.—TAGLIABUE COLD TESTER.

<sup>1</sup> Albrecht, *Ann. Gewerbe-Bauwesen*, xxx, 234 (1892).

<sup>2</sup> *Journ. Soc. Chem. Ind.*, xxxiv, p. 697.

boiled by means of a ring-burner underneath. The steam generated passes to a reflux condenser, so that the loss of water is negligible.

A valve is fitted centrally into the bottom of the cylindrical vessel, and this is operated by means of a loose metal disc covered with sheet asbestos.

The stirring device is connected by a sliding "sleeve" to a pulley, which, in turn, is belt-driven by an electro-motor fitted with a starting handle and speed regulator. The installation is compactly mounted on a substantial base.

The method of testing an oil for demulsification value is as follows:—

Five hundred c.c. of distilled water and 500 c.c. of the oil are heated together in a suitable vessel until the water boils well.

After lifting off the cover the oil and water are transferred to the inner cylindrical vessel of the apparatus, which has been heated by boiling the water in the water-jacket. The cover and stirrers are then replaced on the apparatus

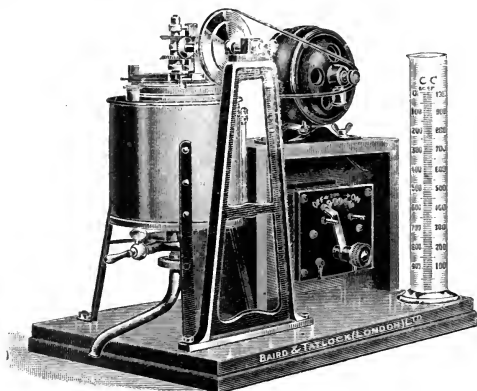

FIG. 281.—PHILIP'S DEMULSIFICATION TESTER.

and firmly secured by the three lugs and clips provided for that purpose; the stirrers are connected to the pulley by the sliding sleeve.

The agitation of the oil and water is commenced by starting the motor, and the speed of the stirring adjusted by the speed-regulator handle. The speed of the pulley should be between 350 and 400 revolutions per minute.

After agitating the mixture of oil and water for five minutes at this speed the mixture is run off from the tester, through a bent pipe, into a previously warmed graduated 1000-c.c. glass cylinder, by raising the insulated disc which opens the valve.

After allowing the apparatus to drain for about a minute, the glass cylinder containing oil, water, and emulsion is set aside to stand for twenty-four hours.

The volume of the separated oil is then read off in cubic centimetres, and this divided by five gives the percentage of oil separated on the amount taken.

The drainage loss amounts to about 2 per cent., so that even an ideal oil does not give a demulsification value greater than about 98 per cent.

Mineral lubricating oils possessing demulsification values of 90 per cent. can be readily obtained commercially, and a large number of samples tested with demulsification values of 90 per cent. and over have been found consistently satisfactory in practical use.

The following are the conditions imposed by the German railways as to the quality of lubricating oils supplied to them:—

#### THE ROYAL PRUSSIAN RAILWAYS.

*Mineral Lubricants for all Divisions.*—The mineral oils to be used for lubricating rolling-stock, steam-engines, and tool-machinery must be delivered one-half as “summer” and one-half as “winter” oil, and comply with the following conditions:—

The *specific gravity* at 20° C. shall lie between the limits of 0.900 and 0.925.

The *viscosity* at the temperatures subjoined shall lie between—

Temperature, . . . . .	20° C.	30° C.	40° C.	50° C.
Highest limit, . . . . .	45° „	20° „	12° „	9° „
Lowest „, . . . . .	25° „	12° „	8° „	6° „

as recorded by a standardised Engler viscometer, and referred to distilled water at 20° C. The flashing-point, tested by the Treumann instrument (see p. 817), shall be above 160° C.

*Resistance to Cold.*—Winter oil must remain fluid at  $-15^{\circ}$  C., and summer oil at  $-5^{\circ}$  C.—*i.e.* it must ascend a glass tube of 6 mm. internal diameter at a minimum rate of 10 mm. per minute, when subjected to the constant pressure of a 50-mm. water column in Schultze’s apparatus (see p. 855). In addition, the oil must be free from water and acid, have only a slight smell, and completely dissolve in petroleum benzine of specific gravity 0.67 to 0.70. It must not contain any foreign substances, or deposit a sediment, even after prolonged standing; neither may it possess any drying properties—*i.e.* it must not resinify or dry to a varnishy stratum on long exposure in thin layers to the action of the air. The addition of mineral oils, or distillation products thereof, to rape oil is strictly prohibited in the conditions prescribed for the latter lubricant in the sub-districts of Altona and Berlin.

#### THE GRAND DUCHY OF BADEN STATE RAILWAY.

The mineral lubricating oil must be prepared from petroleum only, and must not contain any other kind of mineral oil (such as coal-tar oil, brown-coal tar oil, or shale oil), or any other oil of vegetable or animal origin (resin oil or fat oil), or solid fat, ceresin (ozokerite), and such like. Only an exceedingly small proportion of solid hydrocarbons (paraffin) is permissible, and the oil must be perfectly free from gum-like impurities [“schleim”], tar, and resin. No brown coloration—indicative of resin and allied bodies—should result on agitating the oil with an equal volume of sulphuric acid of 1.53 specific gravity. All substances used in refining, such as alkalis, salts, water, and, above all, sulphuric acid, must be absent. The colour must not be too dark, and the oil should be transparent in thin layers; no solid matter must be in suspension, nor should any deposit occur after prolonged standing. The limits of specific gravity at 15° C. are 0.890 to 0.940. On distillation, not more than 10 per cent. by volume should come over below 300° C. (temperature of the oil-vapour), and the undistillable residue must not exceed 7 per cent. by volume. The flashing-point (production of inflammable vapour) must not be below 160° C., open-cup test, or the burning-point below 190° C. (oil temperature). The oil should not froth or “prime” at any temperature, neither should it acidify or dry on being heated for twenty-four hours at 100° C. in thin layers exposed to the air. The viscosity of the mineral lubricant must be at least equal to that of rape oil at temperatures up to 50° C., and—with a view to employment in oilers with wicks—must be at least one and a half times as great as that of

rape oil between 30° and 50° C. (measured by Engler's viscometer). At low temperatures, down to 0° C., it must be sufficiently fluid to allow the wick-oilers to act normally. At -5° C. the oil must be still fluid without exhibiting any separation of solid matter, and must not congeal above -10° C.

#### ROYAL BAVARIAN STATE RAILWAYS.

The mineral lubricating oils supplied must be almost odourless, and quite free from tar, tar oil, creosote oil, paraffin, acid of any kind (beyond a trace, not exceeding 0.029 per cent.), animal and vegetable fats, or fat oils, and must further have a specific gravity of 0.915 (with a margin, up or down, of 0.005), a flashing-point of 190° [method of testing not specified], with an allowance of 10° either way, and a viscosity at 50° C. of 230 to 330 compared with rape oil (100). The viscosity should only diminish slowly between 20° and 150° C. Summer oil should be of relatively higher, and winter oil of relatively lower, viscosity between these figures. Shaken up with water, the oil should not show any flocculent matter. On agitation with potash lye of 1.35 specific gravity, and heating to boiling-point, the lye should remain colourless and clear, and should not undergo any alteration in volume after repeated shaking. Agitation with sulphuric acid of specific gravity 1.6, and warming on a water-bath, should not produce more than a deep yellow (on no account brown) coloration of the acid, nor, on being shaken up with an equal volume of sulphuric acid of 1.4 specific gravity, at an equal initial temperature of 15° C. for both liquids, should the increase of temperature exceed 10° C.—*i.e.* the temperature should not rise higher than 25° C. Oil which "primes" strongly when heated will be considered useless. At -10° C. the oil must flow freely, or be of no greater consistency than "thin salve," and must be still of similar appearance at -16° C., without congelation. No separation of paraffin should occur even at the lowest temperatures, and the insoluble residue (solid constituents) must not exceed 1 per cent.

#### THE HESSIAN LUDWIGSBAHN COMPANY.

Pure, almost inodorous, mineral oil is required, free from tar, tar oil, creosote oil, paraffin, and acid of any kind, or admixture of any description of animal or vegetable fats or oils. The specific gravity at 20° C. must not fall below 0.900, nor exceed 0.925 for cylinder-oil, and 0.915 for axle-oil. The minimum flashing-point of cylinder-oil is fixed at 190° C., and of axle-oil at 160° C. [apparatus not mentioned], with burning-points of 220° and 180° C. respectively. The congealing-points must be as low as possible, and the oils should still flow pretty freely at 0° C. Axle-oil should, at -10° C. (and cylinder-oil at -5° C.), run slowly from a tube 6 mm. in diameter, under a pressure of 50 mm. In applying this test, the oil is to be exposed to the prescribed degree of cold for one hour without being shaken. As regards viscosity, the minimum fixed for axle-oil is 8, and for cylinder-oil 18, Engler units (water=1) at 50° C. The tests with water, caustic potash solution, and sulphuric acid are the same as those prescribed by the Bavarian State railways, as is also the condition referring to priming. The oil should dissolve in petroleum benzine of 0.67 to 0.70 specific gravity, without leaving more than 1 per cent. of residue.

#### THE MAIN-NECKAR RAILWAY.

Pure, double-refined mineral oil is required, of a green or brown colour, free from salts, acids, resins, and tar oil, leaving no residue when filtered, and having the requisite lubricating power to obviate any tendency to heating of

the bearings of locomotives or cars, even at the highest speeds. The range of specific gravity permissible is between 0.875 and 0.910, and no evolution of inflammable vapour should occur below 170° C., nor should the oil congeal above -5° C. On being treated with an equal volume of sulphuric acid of 1.45 specific gravity, at an initial temperature of 15° C., the increase of temperature should not exceed 15°, and when mixed with an equal bulk of the same acid, of 1.53 specific gravity, the oil should not impart any deeper tinge than pale yellow to the acid, either in the cold or on warming.

#### THE PALATINATE RAILWAY.

(a) *Machine-Oil*.—The essential particulars for mineral lubricating oils are freedom from gum-like impurities ["schleim"], resins, acids, alkalies, salts, tar, and water, and absence of drying properties, or liability to undergo alteration after lapse of time. To these must be added a specific gravity of between 0.900 and 0.915 at 15° C., coupled with a very constant degree of consistency within the ordinary limits of temperature. The oil should not congeal at -10° C., and must remain fluid at -5° C. It must have a flashing-point of 160° C., and a burning-point of 180° C. Finally, when heated, frothing should not occur.

(b) *Cylinder-Oil*.—The conditions are identical with those for class (a), with the following exceptions:—Flashing-point, 260° C.; burning-point, 310° C. The oil must remain fluid at 5° C.

#### ROYAL STATE RAILWAYS OF SAXONY.

Mineral lubricants are employed for locomotives as well as for tender and wagon axles. If the oil offered is unsuitable for use in warm portions of the locomotive (cylinder, slide valve, etc.), this must be particularly specified in the tender form. It is essential that the oil be free from acid, tar, resin, and water, neither too thin nor too thick, according to the season, and that it should deposit no sediment on storing. Winter oil is expected to remain perfectly fluid even at -10° C. The tender should state whether the oil is of German, Russian, or American origin, and give in addition particulars of—

1. Viscosity, in degrees Engler, compared with crude rape oil at -10°, -5°, 3°, 18°, and 50° C.
2. Temperature in degrees C. at which ebullition occurs.
3. Temperature in degrees C. at which *visible* vapours are evolved.
4. Temperature in degrees C. at which inflammable vapours are evolved.
5. Burning-temperature, in degrees C., of the oil.
6. Coefficient of friction as compared with crude rape oil.
7. Specific gravity of the oil at 15° C.

#### ROYAL STATE RAILWAYS OF WÜRTEMBERG.

The mineral lubricating oil must be free from gum-like impurities ["schleim"], resins, acids, salts, tar, paraffin residues, and water, and must possess no drying properties. It must neither alter after long storage nor deposit any sediment, and must be thoroughly suitable for the required purpose. Limits of specific gravity, at 15° C. between 0.90 and 0.92, congealing-point not over -10°, minimum flashing-point 160° C., and burning-point 185° C. The oil should not froth when heated, and should have a viscosity (Engler) at 20° C. of eightfold to a hundred times that of water.

## THE STATE RAILWAYS OF ELSASS-LOTHRINGEN.

The conditions and methods of testing are the same as for the Prussian railways, with the subjoined variations:—

Limits of viscosity for summer oil at:—

	20° C.	30° C.	40° C.	50° C.
Highest, . . . . .	2.5	1.3	0.8	0.6
Lowest, . . . . .	1.5	0.8	0.5	0.4

The minimum degree of viscosity for winter oil is fixed at 1.5 at 20° C., all these being determined by Engler's viscometer, taking rape oil, of fifteen times the viscosity of distilled water at 20° C., as the standard. Flashing-point above 140° C. (Pensky-Martens test). Congealing-point—summer oil must remain fluid at 0° C., and winter oil at -10° C., when tested in the manner prescribed by the Prussian railways.

## FUEL OIL.

Oil intended for use as liquid fuel is examined for the presence of water and of carbonaceous matter or dirt capable of blocking the burners, as well as for specific gravity, flash-point, viscosity, or fluidity at 32° F. (freedom from solid hydrocarbons), calorific value, and percentage of sulphur.

The following specification for the purchase of fuel oil for the United States Government was issued by the Bureau of Mines in 1911:—

## “GENERAL SPECIFICATIONS.

“1. In determining the award of a contract, consideration will be given to the quality of the fuel offered by the bidders, as well as the price, and should it appear to be to the best interest of the Government to award a contract at a higher price than that named in the lowest bid or bids received, the contract will be so awarded.

“2. Fuel oil should be either a natural homogeneous oil or a homogeneous residue from a natural oil; if the latter, all constituents having a low flash-point should have been removed by distillation; it should not be composed of a light oil and a heavy residue mixed in such proportions as to give the density desired.

“3. It should not have been distilled at a temperature high enough to burn it, nor at a temperature so high that flecks of carbonaceous matter began to separate.

“4. It should not flash below 60° C. (140° F.) in a closed Abel-Pensky or Pensky-Martens tester.

“5. Its specific gravity should range from 0.85 to 0.96 at 15° C. (59° F.); the oil should be rejected if its specific gravity is above 0.97 at that temperature.

“6. It should be mobile, free from solid or semi-solid bodies, and should flow readily, at ordinary atmospheric temperatures and under a head of 1 foot of oil, through a 4-inch pipe 10 feet in length.

“7. It should not congeal nor become too sluggish to flow at 0° C. (32° F.).

“8. It should have a calorific value of not less than 10,000 calories per gram<sup>1</sup> (18,000 British thermal units per pound); 10,250 calories to be the

<sup>1</sup> Calories  $\times$  1.8 = British thermal units per pound.



standard. A bonus is to be paid or a penalty deducted according to the method stated under section 21, as the fuel oil delivered is above or below this standard.<sup>1</sup>

" 9. It should be rejected if it contains more than 2 per cent. water.

" 10. It should be rejected if it contains more than 1 per cent. sulphur.

" 11. It should not contain more than a trace of sand, clay, or dirt.

" 12. Each bidder must submit an accurate statement regarding the fuel oil he proposes to furnish. This statement should show :—

" (a) The commercial name of the oil.

" (b) The name or designation of the field from which the oil is obtained.

" (c) Whether the oil is a crude oil, a refinery residue, or a distillate.

" (d) The name and location of the refinery, if the oil has been refined at all.

" 13. The fuel oil is to be delivered f.o.b. cars or vessel, according to the manner of shipment, at such places, at such times, and in such quantities as may be required, during the fiscal year ending . . .

" 14. Should the contractor, for any reason, fail to comply with a written order to make delivery, the Government is to be at liberty to buy oil in the open market and charge against the contractor any excess of price, above the contract price, of the fuel oil so purchased.

#### " SAMPLING.

" 15. Deliveries of fuel oil will be sampled by a representative of the Government. Whenever such action is practicable, the oil will be sampled as it is being delivered. The final sample will be made from samples taken from as large a proportion of the delivery as practicable, in order that the final sample may truly represent the delivery.

" 16. The final sample will be sealed and forwarded to the Federal Bureau of Mines, Pittsburgh, Pa., for analysis.

" 17. If the contractor so desires, permission will be given him, or his representative, to witness the sampling of the delivery, and the preparation of the final sample.

" 18. The final sample will be analysed and tested immediately after its receipt in Pittsburgh.

#### " CAUSES FOR REJECTION.

" 19. A contract entered into under the terms of these specifications shall not be binding if, as the result of a practical service test of reasonable duration, the fuel oil fails to give satisfactory results.

" 20. It is understood that the fuel oil delivered during the term of the contract shall be of the quality specified. The frequent or continued failure of the contractor to deliver oil of the specified quality will be considered sufficient cause for the cancellation of the contract."

### GAS OIL.

In the examination of oils for gas-making purposes, it is sometimes only necessary to determine the specific gravity, the percentage distilling below

<sup>1</sup> It is important that the standard fixed should not be higher than can be maintained under the terms of the contract. In the absence of information as to the heating value of the oil, the Bureau of Mines will analyse samples taken from the deliveries to establish the standard heating value, expressed in calories or British thermal units. It will be to the best interests of the contractor to specify a fair standard for the fuel oil he offers, since failure to maintain that standard will cause deductions from the contract price and possibly the cancellation of the contract, while deliveries of higher quality than the standard will result in the contractor receiving premiums.

a specified temperature, and the specific gravity of the residue. Valuable information as to the character of the oil may be obtained by fractional distillation, with a view to ascertaining the range of boiling-points and specific gravities of the distillates. The percentage of sulphur and of carbonaceous residue on distillation to dryness may also have to be determined.

### PARAFFIN TESTING.

The testing of solid paraffin comprises the determination of the melting-point, the percentage of oil and the percentage of water and dirt. The various methods of testing in common use have been somewhat fully treated in papers by D. A. Sutherland,<sup>1</sup> J. Stuart Thomson,<sup>2</sup> and the author.<sup>3</sup>

**Melting-Point.**—The “melting-point” is understood commercially to be the temperature at which the liquefied paraffin commences to solidify. In conducting the “*English test*,” the paraffin is melted in a test-tube about three-quarters of an inch wide, and is then stirred with a thermometer while the tube is held in the air, until a point is reached at which the crystallisation liberates sufficient heat to arrest the cooling and keep the mercurial column in the thermometer stationary for a time. This test resembles Dalican’s method of determining the solidifying points of fatty acids.<sup>4</sup> In Saybolt’s apparatus for applying the test to a number of samples simultaneously, the melted paraffin is contained in a series of parallel-troughs resting on a carriage which travels backwards and forwards. The thermometers are held stationary in a frame, with their bulbs just immersed.

In carrying out the “*American test*,” a hemispherical cup,  $3\frac{3}{4}$  inches in diameter, is three-fourths filled with the melted paraffin, which is then allowed to cool spontaneously until a very thin film extends from the sides of the vessel to a thermometer with a round bulb half an inch in diameter, suspended so that the bulb is three-fourths immersed, in the centre of the dish. The American test usually indicates a “melting-point” from  $2\frac{1}{2}^{\circ}$  to  $3^{\circ}$  F. higher than the English test.

**Capillary Tube Method.**—Another method of determining the “melting-point” consists in noting the temperature of solidification of a minute quantity of the sample previously fused in a capillary tube, care being taken not to over-heat it during fusion. The capillary tube is allowed to cool slowly by the side of a thermometer in a beaker of water. Le Sueur and Crossley<sup>5</sup> have suggested a modification which they state has given very concordant results. A capillary tube, open at both ends, has its lower end beneath the surface of a small quantity of the sample in powder contained in a small thin test-tube, which is attached side by side to a thermometer. On being slowly heated in a beaker of water the sample liquefies and suddenly flows up the tube by capillary attraction, the temperature at which this occurs being recorded as the melting-point.

**Tagliabue’s Paraffin-Tester.**—An instrument sold by Charles J. Tagliabue, of New York, for determining the melting-point of paraffin, consists of a metal funnel, with a water-jacket in communication with a heating vessel. The test is made in the following manner:—The heating-vessel is nearly filled with water, and closed with a cork which carries a thermometer. A lighted spirit-lamp is then placed beneath it, and the temperature of the water (which circulates through the jacket of the funnel) is raised to, and maintained at, a

<sup>1</sup> *Journ. Soc. Chem. Ind.*, vi, 123 and 271 (1887).

<sup>2</sup> *Ibid.*, x, 342 (1891).

<sup>3</sup> *Ibid.*, iii, 430 (1884); v, 125 (1886); and Cantor Lectures at the Society of Arts, 1886.

<sup>4</sup> *Journ. Soc. Chem. Ind.*, viii, 424 (1889).

<sup>5</sup> *Ibid.*, xvii, 988 (1898).

point about 15° or 20° F. above the anticipated melting-point of the sample to be tested. Another thermometer having been fixed in the funnel so that its bulb occupies the apex, "about a spoonful" of the sample, finely broken up, is put into the funnel. As the paraffin melts and drops from the bulb of the thermometer, it is carefully watched, and as soon as it is perfectly transparent, the temperature indicated by the thermometer is recorded as the melting-point of the sample.

**Estimation of Oil.**—The determination of *oil* is made by pressing the paraffin and noting the loss in weight, but as the results vary according to the temperature adopted, the amount and *duration* of the pressure, and the quantity of material in relation to the surface subjected to pressure, the test is a purely arbitrary one. Moreover, there is no natural line of demarcation between the solid and liquid hydrocarbons present. In averaging the sample and preparing it for testing, it will be found convenient to pass it through a small mincing-machine.

**Lever Presses.**—Fig. 282 represents a press employed many years ago in the laboratory of the author. It has a steel crosshead, the deflection of which is magnified by levers so as to indicate the pressure. Fig. 283 shows the press which the author now uses. In this the pressure is regulated by a heavily weighted lever. Each press has a circular press-cup and a plunger 5½ inches in diameter, and in testing American paraffin scale, a pressure of 9 tons on the total surface is used. The pressure is applied for five minutes at a temperature of 60° F. to 500 grains of the scale placed between circular pieces of calico cut with a steel punch to fit the cup. The expressed oil is absorbed by a number

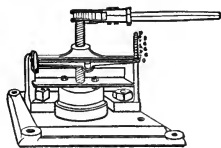

FIG. 282.—SCREW PRESS.

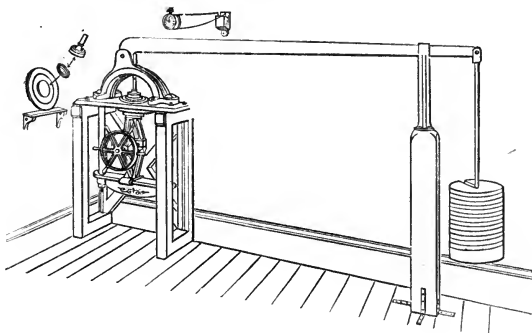

FIG. 283.—LEVER PRESS.

of discs of blotting-paper placed above and below the cloths containing the cake. The paraffin is brought to the standard temperature before treatment, and thermometers inserted in mercury cups indicate the temperature of the press-cup and plunger. The plunger and cup are detachable from the bed-plate, etc., so that they may be cooled in water at 60° F.

Figs. 284 and 285 illustrate a press designed by Mr. M'Cutchon. This is provided with a helical spring, the extent of compression of which indicates the pressure applied.

**Hydraulic Press.**—A compact hydraulic press with Bourdon gauge, introduced by Messrs. Clarkson and Beckett, for paraffin testing, is shown in fig. 286.

**Estimation of Water.**—The water may be determined in paraffin scale by heating a weighed quantity (preferably 25 grams) in a tared evaporating dish with constant stirring with a thermometer until the water is driven off. The loss shows the amount of water. The material should be raised to and maintained at a temperature somewhat higher than the boiling-point of water. When the amount of water is large, there is some danger of loss from spurting, and the operation is also tedious. It may then be determined by distillation or subsidence, the paraffin being kept in the latter case in a molten condition until all the water has separated. A convenient apparatus, introduced by Sutherland, for the subsidence-test, consists of a bulbed tube, the upper, pear-shaped portion of which is  $2\frac{1}{2}$  inches wide and  $9\frac{1}{2}$  inches long, and the lower, tubular portion three-eighths of an inch in diameter, and graduated in tenths of a cubic

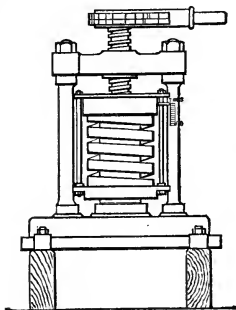

FIG. 284.

M'Cutcheon Press.

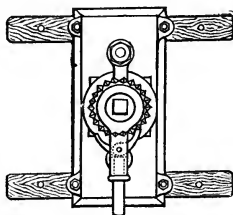

FIG. 285.

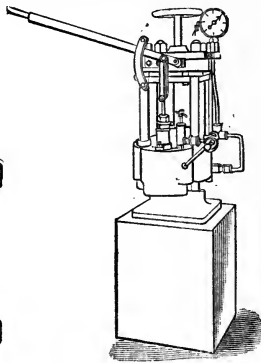

FIG. 286.—

HYDRAULIC PRESS.

centimetre, or in grains. In performing the test, 64 grams (1000 grains) is placed in the tube, which is immersed in water at  $150^{\circ}$  F. until the scale has melted, and the water has subsided, the vessel being tapped to facilitate the separation. The lower part of the tube is then plunged into cold water, so that a film of paraffin solidifies over the separated water. As much as possible of the paraffin having been poured off, the remainder is removed by agitation with warm, "hydrated" petroleum spirit. The water is read off at  $60^{\circ}$  F. Another method of estimating the water when the amount is large, consists in treating the scale with petroleum spirit, already containing as much water as it will take up, and measuring the water thus separated. A method of estimating water by distillation is described on page 865.

**Estimation of Dirt.**—The dirt is estimated with the water in the above tests, but when the quantity present is considerable, it is collected on a filter paper, washed with mineral spirit, dried, and weighed. In Scotch scale the dirt rarely exceeds 0.2 per cent., and consists chiefly of vegetable fibre from the cloths used in pressing, and of iron oxide from the condenser-worms.

**Scottish Methods.**—The following methods of testing Scotch paraffin scale and heavy mineral oils have been adopted by the chief chemists of the companies constituting the Scottish Mineral Oil Association, by Price's Patent

Candle Company, and by the author. They were discussed in detail by Mr. J. Stuart Thomson in the paper already referred to:—

### I. SCALE ANALYSIS.

1. *Sampling of Hard Scale.*—The sample is to be taken by means of a metal tube, which is made slightly conical; the small end is inserted in the scale, and by means of a handle, which is removable, it is forced through the scale to be sampled. By this means a cylindrical core of paraffin is obtained.

Care must be taken to see that the tube is of such a length that the sample will represent the whole length or depth of the cask, wagon, or bing.

2. *Preservation of Samples of Scale.*—Immediately after the sample has been drawn, it is to be thoroughly mixed, placed in suitable wide-mouthed bottles, which may be closed either with glass stoppers or good corks; if the latter are used, they should be covered with paraffin paper, or soaked in melted paraffin wax, before being inserted. The bottles are then finally sealed in the usual manner. The scale should be tightly packed into the bottles, which should be completely filled.

3. *Determination of Oil in Scale.* (a) *Press to be used.*—While no one special form of press is recommended for general adoption, the press used must have some arrangement for indicating the pressure applied. The cup in which the scale is placed during the application of pressure to have an area of 20 square inches.

(b) *Preparation of the Sample.*—A quantity of the scale, after having been freed from water and dirt by melting and subsidence, is to be allowed to cool overnight to a temperature of 60° F. The solid mass is then ground to a fine powder, a portion of which is used in the determination of the oil.

(c) *Quantity of Scale to be used.*—The quantity of scale to be used in the determination of oil is to be 250 grains, which quantity may, however, be reduced to 150 grains in the event of the scale containing much oil (over 7 per cent.). With "soft" scale the smaller quantity should be taken.

(d) *Temperature at which the Scale is to be Pressed.*—The temperature of the scale and the press is to be 60° F.

(e) *Time which the Scale is to remain under Pressure.*—The scale is to remain under pressure for fifteen minutes.

(f) *Pressing Cloths and Papers.*—Fine linen pressing-cloths and a number of layers of filter-paper, sufficient to absorb all the oil, to be used. The exterior papers must not be soiled by oil.

(g) *Pressure to be applied.*—The maximum pressure is to be 10 cwts. per square inch, and the working pressure 9 cwts. per square inch.

4. *Determination of Water in Scale.*—The amount of water present in scale may be determined by either of the following processes:—

(a) *Distillation from a Copper Flask.*—From 1 to 2 lbs. of the scale are heated in a conical copper flask of about the dimensions shown in fig. 287; this is connected to an ordinary Liebig condenser. By means of a powerful Bunsen burner or lamp, the water, accompanied by a small quantity of light oil, is volatilised and condensed. The distillate is received in a narrow graduated measure, so that the volume of water can be readily ascertained. As a

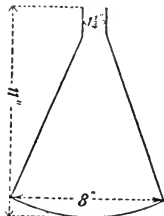

FIG. 287. — DISTILLATION FLASK FOR SCALE ANALYSIS.

little water usually adheres to the side of the condenser tube, this is to be washed out with hydrated gasoline or naphtha, and added to the principal quantity.

(b) *Price's Company's Method*.—Five hundred grains of the scale to be tested are weighed in a tared porcelain basin, and heated with constant stirring to 230° F., until bubbles cease to be given off; the loss is then determined.

Five hundred grains of the same scale, which has been freed of its water and dirt by melting at a gentle heat and subsidence, are to be heated in the same way, to a similar temperature, for the same time, and the loss again determined. The loss in the second instance is now to be deducted from the loss found in the first experiment, and the remainder is then to be taken as the quantity of water present.

5. *Determination of Dirt in Scale*.—The amount of dirt present in scale is to be determined by melting a weighed quantity of the scale, and, after subsidence, pouring off the clear paraffin. The residue is then mixed with naphtha, thrown on a weighed dry filter paper, washed with naphtha or gasoline, dried, and weighed. When available, the quantity of scale to be used in the determination of the percentage of dirt should not be less than 7000 grains.

6. *Calculation of the Results of the Analysis of Scale*.—As the oil is determined on scale which has been freed from water and dirt, the result must be calculated back to the original scale containing water and dirt.

7. *Determination of the Melting- (Setting-) Point of Solid Paraffin*.—This is to be determined by what is known as the "English" test—*i.e.* a test tube about 1 inch in diameter is filled to the depth of about 2 inches with the melted paraffin, a small thermometer is inserted, and the whole steadily stirred, while the test tube and its contents are allowed to cool slowly. The temperature at which the thermometer remains stationary for a short time is the melting- (setting-) point.

## II. FLASHING-POINT OF HEAVY MINERAL OIL.

8. *Determination of the Flashing-Point of Heavy Mineral Oil*.—The oil-cup and cover of the ordinary "Abel" flash-point apparatus are to be employed. The cup is filled with oil in the usual manner, and the rate of heating is to be such that at least fifteen minutes are taken in raising the temperature of the oil to 300° F. In the event, however, of a dispute arising as to the correct flashing-point of a heavy mineral oil, the question is to be decided by means of the Pensky-Martens apparatus.<sup>1</sup>

## III. VISCOSITY OF MINERAL OIL.

9. *Determination of the Viscosity of Mineral Oil*.—The instrument known as the "Redwood" viscometer is that which is to be employed in the determination of the viscosity of mineral oils. The instrument is to be standardised according to the directions given by Sir Boverton Redwood.<sup>2</sup> Ordinary results are to be expressed as the time in seconds which 50 c.c. of the oil take to flow through the orifice, at a temperature of 70° F.

## IV. SETTING-POINT OF MINERAL OIL.

10. *Determination of the Setting-Point of Mineral Oil*.—This is determined in the following manner:—Into a test-tube having a diameter of about 1¼ inch, the oil to be tested is added to the depth of about 2 inches; the tube

<sup>1</sup> *Journ. Soc. Chem. Ind.*, viii, 734.

<sup>2</sup> *Ibid.*, v, 127.

is then immersed in a freezing mixture, the oil being slowly stirred with a thermometer till it is cooled down considerably below the temperature at which solid paraffin first appears. The tube is then removed from the freezing mixture, the oil constantly stirred with the thermometer, and the point carefully watched at which the last trace of solid paraffin disappears. This operation is repeated with the same sample of oil until two experiments give concordant results, the temperature so found being the setting-point.

### PETROLEUM RESIDUUM.

The rules of the New York Produce Exchange provide that "Residuum shall be understood to be the refuse from the distillation of crude petroleum, free from coke and water, and from any foreign impurities, and of gravity from 16° to 21° Baumé."

The proportion of *coke* may be determined by diluting a weighed quantity of the residuum with kerosene, passing the mixture through a filter of fine muslin, and washing, drying, and weighing the solid matter thus separated. If there is reason to suspect the presence of earthy matter, contained in the crude petroleum from which the residuum was obtained, the proportion of carbon should be determined by ignition.

The amount of *water* present may be ascertained in the manner described in connection with the testing of crude petroleum. The author finds it convenient to employ, for the separation of the water, a tube about 6 inches in length and about half an inch in diameter, graduated from the bottom in tenths of a cubic centimetre up to 10 c.c., and surmounted by a glass-stoppered spherical bulb about 4 inches in diameter. Two hundred and fifty grams of the oil is taken for the test, and this is diluted to any required extent with petroleum spirit or kerosene of low specific gravity. The bulbed tube is placed in a water-bath maintained at a temperature of about 150° F., until the whole of the water has separated and forms a distinct stratum beneath the oil in the graduated tube. The quantity of water is then noted at 40° F., each cubic centimetre representing 0.4 per cent.

In cases where samples are otherwise inappreciably volatile at 230° F. their water contents may be estimated by weighing, say, 25 grams into a glass dish, heating to that temperature on a sand-bath, and stirring continuously with a thermometer, until bubbles of steam cease to form. The sample is then allowed to cool, is reweighed, and the loss of weight in grams multiplied by four represents the percentage of water.

The estimation may also be carried out by distilling carefully over a naked flame from a tubulated retort, say, 250 c.c. of oil. The water distilled off is collected in a small measure graduated in cubic centimetres and calculated to percentage.

**Chemical Examination.**—The chemical examination of the raw materials and products to which this work relates, as distinguished from the application of the usual physical tests already described, is not, as a rule, necessary, and its character varies with the use which is to be made of the material. The principal chemical tests were fully described in Mr. Alfred H. Allen's *Commercial Organic Analysis*, 2nd ed., ii., and from that work, the portion of which relating to petroleum was submitted by Mr. Allen to the author for perusal and revision, a considerable amount of the following matter is taken.

It has been already shown in the section dealing with the Chemistry of Petroleum, etc., and in that treating of the Shale-Oil Industry, that the petroleum of America consists mainly of members of the paraffin group; Russian

petroleum of naphthenes, which are isomeric with the olefines; and shale-oil, very largely of hydrocarbons of the olefine group. The action of concentrated nitric and sulphuric acids on shale-oil is much more energetic than on petroleum, and may serve to distinguish these products, but a better method consists in the treatment with bromine, which has no action on the paraffins or naphthenes, but is readily absorbed by olefines. The following method of applying the **bromine test** to commercial products from shale and petroleum was recommended by Mr. Allen:—An approximately decinormal solution of bromine is made by dissolving 2 c.c. of bromine in 750 c.c. of recently distilled carbon bisulphide, and the solution having been dried by adding some lumps of fused calcium chloride, is preserved in the dark. From 0.3 to 1 gram of the oil, or a certain volume of a solution of the oil in carbon bisulphide containing a known amount of the oil, is weighed or measured out into a perfectly dry stoppered flask or separator, and the solution is diluted, if necessary, with carbon bisulphide (dried over calcium chloride) to about 25 c.c. Then 25 c.c. of the bromide solution is added, and the flask is stoppered, agitated, and left in the dark for a quarter of an hour. If the liquid is not distinctly red after the agitation, a further quantity of the bromine solution is added without delay. After a quarter of an hour an excess of an aqueous solution of potassium iodide is poured in, and the mixture is agitated. The bromine which was not absorbed by the oil having thus been replaced by an equivalent amount of free iodine, the flask is removed to a light place and the contents titrated with a decinormal solution of sodium thiosulphate, made by dissolving 24.8 grams of the crystallised salt in one litre of water. The titration is conducted in the usual manner, the final change being rendered more sharp by adding a few drops of starch solution when the bisulphide is nearly decolorised. The bromine solution used requires to be occasionally standardised by treating 25 c.c. of its solution in carbon bisulphide with potassium iodide, and titrating exactly as above. The difference between the volume of thiosulphate now required, and that used after treating the oil, represents the volume corresponding with the amount of bromine absorbed. One c.c. of the thiosulphate solution should correspond with 0.008 gram of bromine. If the crystalline thiosulphate used be pure, and be crushed and dried between blotting-paper before being weighed out, the solution will contain so nearly the right proportion of the salt that, if it be required for ordinary use, there is no necessity to standardise it by iodine. It is found that if the bromine treatment of the oil be allowed to proceed in the light (even if diffused) a markedly larger quantity of bromine is absorbed. The table on the next page gives the results obtained by Mr. Allen in the application of this system of testing to a number of oils.

MM. A. Riche and G. Halphen<sup>1</sup> many years ago devised a process for determining whether a petroleum distillate, such as kerosene, has been obtained from American or from Russian crude petroleum, and for distinguishing crude petroleum from mixtures of petroleum distillate and residuum. The process consists in the gradual addition, by means of a burette, of a mixture of equal volumes of anhydrous chloroform and 93 per cent. alcohol to 4 grams of the sample of oil, until solution is effected and the liquid becomes clear. In the case of petroleum distillates, it was found, as the result of a large number of experiments, that while with the more volatile fractions obtained respectively from American and Russian crude petroleum, there was but little difference in solubility, with the fractions of higher boiling-points, having densities of 0.800 and upwards, the American product required a considerably larger

<sup>1</sup> *Journ. Pharm. Chim.*, xxx, 289 (1894); *Journ. Soc. Chem. Ind.*, xiv, 190 (1895).



quantity of the solvent to produce a clear liquid than sufficed for the Russian product of corresponding specific gravity. As regards the other application of the process, it was found that samples of crude petroleum required much more of the solvent to produce a clear liquid than fractions of the same specific gravity obtained by distillation.

The author has found this process useful in the approximate determination of the proportions of American and Russian kerosene present in mixtures of these two products. Twenty-five per cent., or less, of Russian kerosene, in admixture with American kerosene, may be detected, but it is necessary to pay particular attention to the strength of the alcohol used in preparing the solvent liquid, very slight differences in the amount of water having a marked effect upon the results. A number of blank experiments should, therefore, be

TABLE CXLVIII.—BROMINATION OF OILS.

Description of Substance.	Sp. Gr. at 60° F. (= 15·5° C.)	Grams of Bromine reacting with 100 Grams of Sample.	Bromine as HBr per 100 Grams of Sample.
<i>Gasolines—</i>			
From shale, . . . . .	0·665	62·2	1·1
From American petroleum . . . . .	0·650	17·9	3·1
<i>Naphthas—</i>			
Shale naphtha, . . . . .	0·720	67·2	4·0
C-naphtha from American petroleum, . . . . .	0·706	18·3	...
<i>Burning oils—</i>			
From shale, . . . . .	0·813	51·3	3·0
From American petroleum, . . . . .	0·800	34·8	...
From Russian petroleum, . . . . .	0·821	2·0	0·1
<i>Intermediate oils—</i>			
From shale, . . . . .	0·850	48·2	...
“Mineral sperm oil” (American petroleum), . . . . .	0·847	32·3	...
“Pyronaphtha” (Russian petroleum), . . . . .	0·868	1·9	0·1
<i>Lubricating oils—</i>			
From shale, . . . . .	0·890	25·6	5·8
Cylinder oil (from shale), . . . . .	0·890	11·0	...
From American petroleum (heavy spindle-oil), . . . . .	0·900	11·7	...
From Russian petroleum, . . . . .	0·904	4·9	0·8
“Champion oil” (American petroleum), . . . . .	0·911	9·9	0·8
Cylinder oil (Russian petroleum), . . . . .	0·909	5·8	0·6
<i>Vaselines—</i>			
From American petroleum (Chesebrough Co.), . . . . .	0·856	11·3	1·8
From Russian petroleum, . . . . .	...	1·7	0·3
<i>Paraffin waxes—</i>			
From shale (m. p. 52° C.), . . . . .	...	1·7	0·5
From petroleum (m. p. 54° C.), . . . . .	...	0·9	0·2

performed with oils of known origin and mixtures in various proportions, with the freshly prepared test-liquid, before using it in the examination of unknown samples. The following results were obtained in the author's laboratory:—

	c.c. of solvent required for 4 grams.	
	Actual.	Theoretical.
A. American kerosene, specific gravity 0·797,	6·1	..
B. Russian kerosene, “ ” 0·824,	4·8	..
25 per cent. A, and 75 per cent. B,	5·1	5·2
50 “ ” 50 “ ”	5·5	5·5
75 “ ” 25 “ ”	5·8	5·8

For determining the ash yielded by petroleum, it is usual to evaporate down a known volume of the oil and ignite and weigh the residue. It is best to distil down 1000 grams of the oil to about 40 grams, and to transfer this to a weighed platinum dish, evaporate to dryness, ignite, and weigh. A. Stepanoff<sup>1</sup> recommends the following method as avoiding the unpleasant production of soot which otherwise takes place, the bulk of the oil being evaporated off prior to the ignition proper, but the whole test being performed in the weighed dish:—70 to 90 grams of oil is heated in a platinum dish, over which is placed a closely-fitting conical or hemispherical glass cover connected to a condenser, a receiver, and finally a powerful aspirator, by means of tubing. In about fifteen minutes the greater part of the oil will have been evaporated and collected in the receiver. A fresh portion is then poured into the dish, and so on, until 200 to 300 grams have been treated. The comparatively small residue of coke remaining in the dish may then be heated until no more fumes are evolved, and finally ignited over a blowpipe or in a current of oxygen.

A mineral lubricating oil should volatilise without the production of any very pungent odour, and if the vapour is ignited and the flame extinguished, there should be no smell of resin or acrolein. On ignition the oil should leave no inorganic residue, or only a trace (less than 0.05 per cent.). If a residue is left, the oil may contain alkali, or the soap of an alkali metal, or palmitate or oleate of aluminium. The presence of the last two may be detected by agitating the oil with ether and dilute acid, separating the aqueous layer and adding to it a slight excess of ammonia, when a white gelatinous precipitate will be thrown down if either of the aluminium compounds in question is present.

The following particulars of the "alkali test" for Russian petroleum products, which has already been briefly described on p. 756, have been given by K. Lisenko and A. Stepanoff.<sup>2</sup>

About 1884 endeavours were made in the Russian petroleum districts to reduce the quantity of caustic soda used in the refining of petroleum. Kerosene was obtained which satisfied the usual tests, but in practice was found unsuitable for use as lamp-oil, as it did not rise freely in the wick. Investigation proved that this was due to the presence, in the kerosene, of small quantities of saponaceous salts, and analysis sometimes showed as much as 0.04 gram of ash from 1000 grams of kerosene, this ash consisting of CaO, MgO, Fe<sub>2</sub>O<sub>3</sub>, Na<sub>2</sub>O, and SO<sub>3</sub>. Further investigation proved that for a lamp-oil, the ash should certainly not exceed 0.01 gram per 1000 grams of oil, and that in the best oils it generally varied between 0.004 and 0.007 gram. The presence of these soaps or salts is equally detrimental in lubricating oils.

As the ash-determination is troublesome, and somewhat uncertain on account of possible loss of sodium salts by volatilisation, the so-called "alkali test" was introduced. Though used with various slight modifications, it consists mainly in mixing, in a flask, 300 or 500 c.c. of kerosene with 6 or 10 c.c. of a 2 per cent. solution of caustic soda, warming to 60° or 70° C., and shaking the whole violently for five minutes. The mixture is then transferred to a separating funnel, the alkaline extract filtered through a double filter, and acidulated with HCl. The acids in the petroleum and in the saponaceous salts which are extracted by the alkali are thus precipitated, and the degree of turbidity produced thereby indicates the amount of impurity present in the oil. The turbidity—at one time simply stated roughly as satisfactory or the

<sup>1</sup> *Chem. Zeit. Rep.*, xvi, 348 (1892).

<sup>2</sup> *Dingler's polyt. Journ.*, ccxc, 139 (1893); *Journ. Soc. Chem. Ind.*, xiii, 177, 178 (1894).

reverse—is now estimated by the size of print which can be read through the opalescent liquid contained in a glass cylinder of given diameter, the operator being required to specify the diameter of the cylinder and the size of print he can just discern. The kerosenes are now divided into classes according to the results given by this “alkali test,” and a definitely fixed scale is being constructed. Even the best kerosenes give a slight opalescence. The theory of the test is clear—viz. that the soaps and acids present in the oil are dissolved in the dilute alkali, and on acidifying the alkaline extract, the acids which are insoluble in water render the extract opalescent. In testing lubricating oils, which generally contain a considerably larger quantity of ash (sometimes as much as 0.125 gram per 1000 grams of oil), the test is somewhat modified. In this case 5 c.c. of a 1.5 per cent. caustic soda solution is mixed with 10 c.c. of the oil, the whole heated to 80° C., shaken violently for some time, allowed to stand at 70° C. for two or three hours to settle, and then examined. If the aqueous layer is then milky, and there is a more or less considerable precipitate between the aqueous and the oil layers, the oil is undoubtedly not sufficiently purified. In most cases the aqueous solution is clear, but a more or less marked yellowish-red film is seen at the point of contact of the two layers. In such cases, if the ash is small, the oil is a satisfactory lubricating oil. It only very rarely occurs that the oil is so absolutely free from salts and acids as to give no film. Another form of this test sometimes used for kerosene is to shake the oil to be tested, with a small quantity of strong caustic soda solution. If the kerosene is pure, the two liquids rapidly separate again with a perfectly bright contact surface. If the kerosene is impure, a whitish film forms at the point of contact of the two liquids. This form of test, however, only decides between pure and impure oil, and gives no indication of the degree of impurity.

The view held in Baku and elsewhere of this alkali test was that the alkali dissolved out the soaps (possibly in the form of basic salts), and that the test was a definite proof of the presence or absence of these soaps in the oil. Lisenko and Stepanoff have carefully investigated this matter, and their conclusions (confirmatory, in many respects, of the work of Doroschenko and of Engler) are as follows:—These saponaceous salts are almost absolutely insoluble in pure neutral petroleum, but dissolve readily in the same if it contains a trace of naphtha acids. Almost all petroleum contains more or less of these acids, which are generally mixtures of hydro-aromatic and sulphonic acids and phenolic compounds. Kerosene, when distilled in the air, or even when shaken at 70° to 80° C. with air, usually undergoes slight oxidation with formation of traces of these acid compounds, so that absolutely neutral kerosene is rarely met with. The salts of these naphtha acids undergo partial hydrolysis in the presence of water, and though excess of alkali in some degree prevents this hydrolysis, the latter is not completely stopped till the excess of caustic soda amounts to at least 10 per cent. of the water. Thus, in the purification of petroleum by weak alkali, as now often practised, and subsequent washing with water, part of the salts first formed becomes again hydrolysed, the acid so liberated is taken up again by the petroleum, and the acid petroleum in its turn redissolves some of the salts. Lisenko and Stepanoff, therefore, believe that for good purification, final treatment with strong caustic alkali should be adopted. The presence of small quantities of these naphtha acids in the oil does not seem to be detrimental so long as no salts are present. From this point of view the alkali test, as at present carried out, is unsatisfactory, as it really only determines the presence or absence of these naphtha acids without deciding whether they are present in the free state alone, or also in the form of

the detrimental salts. As the ash-determination is difficult, and not altogether satisfactory, testing for these salts is at present unsatisfactory. The authors suggest as a test which, as far as preliminary trials go, seems to be preferable—the shaking of the petroleum to be tested with water containing a few drops of phenolphthalein. If salts are present, hydrolysis takes place, and the liberated alkali, being taken up by the water (whilst the acid remains in the oil), colours the solution violet. The aqueous extract may even be titrated. Further investigation of this test is, however, required.

As a test for the presence of **sulphur-compounds** in mineral spirit, the sample may be boiled for a few minutes with alcohol and a few drops of ammonia, and nitrate of silver solution then added, when there should be no brown coloration. Mineral spirit containing sulphur-compounds is unfit for use as a substitute for oil of turpentine, as it is liable to cause darkening of some light-coloured paints. Warm water agitated with mineral spirit should not acquire the faintest acidity, and should give no precipitate with barium chloride. Mineral burning-oils may contain sulphur-compounds originally present in the raw materials from which they were obtained. Oils which, like those produced by the process of “cracking,” consist largely of olefines, are also liable to contain sulphonates resulting from the action on the hydrocarbons of the sulphuric acid used in the process of refining.

There are several methods in use for the detection and estimation of sulphur. The “litharge test” in use in Canada has already been referred to on p. 555. A simple qualitative test consists in heating the oil with a fragment of metallic sodium to the boiling-point for some time, in a flask provided with an inverted condenser. After cooling, water is added drop by drop until the sodium has been dissolved. More water is then added; the water is separated and a drop of sodium nitroprusside is added. A fine violet-blue colour is produced if the petroleum contains sulphur. This test only operates with sulphur-compounds which form sodium sulphide with sodium, and thus discriminates between such sulphur-compounds and sulphuric acid. The sodium nitroprusside is prepared by warming a few crystals of potassium ferricyanide with strong nitric acid until red fumes are copiously evolved, the solution being then diluted and neutralised with sodium carbonate. Carius converts the sulphur into sulphuric acid by heating the oil with nitric acid, the sulphuric acid being finally precipitated with barium chloride, but the action of the nitric acid, especially in the case of shale-oils, often fails to result in the complete oxidation of the sulphur. Many chemists estimate the sulphur by an ordinary “combustion” with oxygen. Höland<sup>1</sup> employs for the combustion-process an intimate mixture of finely divided pure barium carbonate and potassium chlorate. A potash-glass combustion-tube 40 centimetres long is used, sealed at one end. The liquid to be examined is dropped in from a weighed pipette, and spread about over as large a surface of this mixture as possible, conveniently by diluting with ether, and subsequently allowing this solvent to evaporate. After the combustion is over, the contents of the tube are treated with hydrochloric acid and the undissolved barium sulphate weighed. Evolution of sulphuretted hydrogen indicates imperfect oxidation. With volatile oils, or petroleum containing the more volatile hydrocarbons, the process of combustion in a current of oxygen, or that of treatment with an oxidising mixture, does not answer well, as explosions are liable to occur. In such cases the author was accustomed to estimate the sulphur by burning a weighed quantity of the oil in a lamp, and passing the products of combustion through a cylinder containing glass beads moistened with ammonia, such as is employed in determining the sulphur in

<sup>1</sup> *Chem. Zeit.*, xvii, 99 and 130 (1893).

coal-gas. The sulphur is precipitated and weighed as barium sulphate. Heavy or viscous oils, which would not burn alone, must be diluted with kerosene known to contain no sulphur. The author has found as much as 119 grains of sulphur per gallon in Canadian kerosene. The products of combustion of this oil injured the plants in a conservatory.

An improved modification of the method just described is now in use.

The method depends upon the combustion of the sample in a current of air and the absorption of the products of combustion in solutions of alkaline oxidising agents. The sulphur of the sample is thus obtained as a sulphate and may be estimated by precipitation as barium sulphate in the usual manner.

A known weight of the sample is accurately weighed into a glass bottle of about 40 c.c. capacity, and a cork, through which passes a piece of silica tubing about 6 millimetres in diameter and about 4 centimetres long, is fitted into the neck. A short length of loose cotton wick is inserted through the silica tubing to the bottom of the bottle. A suitable solvent, free from sulphur, such as absolute alcohol or amyl acetate, or a mixture of the two, is added to the weighed oil. For oils containing a large percentage of sulphur about 1 gram of oil is sufficient, but a larger amount may be taken with advantage if the oil is readily combustible and of low sulphur content. The amount of solvent added should be measured.

Sufficient solvent should be added to give a solution of the oil which will burn readily without smoke. The lamp is placed under a chimney-tube about 5 centimetres in diameter and 20 centimetres long which is open at the bottom and has the upper end drawn and fused to a glass tube about 6 millimetres in diameter. The latter is bent at two right angles so that the chimney-tube somewhat resembles an inverted U, with part of one arm consisting of 5 centimetres tubing and all the remainder of 6 millimetres tubing. The narrow tube passes to the bottom of a small flask through a cork provided with two holes and closely fitting the neck of the flask. Another tube, passing just through the second hole in the cork, connects the flask to the inlet of a Drechsel wash-bottle, the outlet of which is connected to a second Drechsel bottle. The latter is connected to a final washer which is packed with short lengths of glass rod. An ordinary U-tube serves quite well for the final washer. The whole apparatus is connected to a water pump or other suitable exhausting apparatus so that a steady current of air may be drawn through the apparatus through the chimney-tube. The flask, which is immersed in a beaker of cold water, contains 20 c.c. of sodium hypobromite solution. The two Drechsel bottles each contain 20 c.c. of an aqueous solution of sodium peroxide, and the final washer 2 c.c. of sodium hypobromite solution. Distilled water may be added to the contents of the washers to increase the amount of liquid if required.

When air is passing through the apparatus the lamp is lighted and the whole of the oil is burned out of the lamp by adding two or three successive quantities of solvent when the previous contents of the lamp have been consumed. At the completion of the combustion the contents of the washers are transferred to a beaker with rinsings of distilled water and acidified with hydrochloric acid. After the evolution of gas has ceased the liquid is boiled and the sulphur is precipitated as barium sulphate. The amount of barium sulphate obtained is then converted into the amount of sulphur in the weight of oil taken.

The sodium hypobromite solution may be made up by adding 2.5 c.c. of pure bromine to 100 c.c. of 10 per cent. aqueous caustic soda solution. A 10 per cent. solution of pure sodium peroxide is suitable for the Drechsel washers.

A blank experiment with the same quantities of solvent and of reagents is essential.

The method described has been found unsuitable for use with pitchy or asphaltic oils, but in other cases the results obtained are concordant with those obtained by the use of the bomb method.

The following modification of the Burton-Sauer method is described by C. F. Mabery<sup>1</sup> as being of service in the estimation of the sulphur present in Canada and Ohio petroleum:—The substance contained in a porcelain boat is burnt in a current of air, the products of combustion passing through a dilute solution of caustic soda. The combustion-tube (18 mm. internal diameter) is constricted at the middle, and the air passes in from the rear through a narrow tube which reaches this constriction. The forward part of the combustion tube is connected with a U-tube (34 centimetres high, 25 millimetres internal diameter) which is partially filled with broken glass, and contains 50 c.c. of caustic soda solution, of a strength corresponding to 1 mgrm. or 5 mgrms. of sulphur per cubic centimetre, according to the amount of sulphur in the oil under investigation. The titration of the excess of alkali is performed in the U-tube itself, methyl-orange being used as indicator. No nitrogen-acids are formed during the combustion, and the results agree closely with those obtained by the Carius method.

The sulphur present in comparatively non-volatile descriptions of petroleum, bitumen, etc., may be estimated by the magnesia-soda process. This consists in making a mixture of about 1 gram of the substance with  $1\frac{1}{2}$  gram of a mixture of 2 parts of calcined magnesia and 1 part of sodium carbonate, and igniting it in a platinum crucible for over an hour. The mass is extracted with water with the addition of bromine to ensure perfect oxidation, the solution is then filtered, acidulated with hydrochloric acid, heated to expel bromine, and the sulphuric acid, into which form the whole of the sulphur has been converted, is precipitated with barium chloride. Magnesia and sodium carbonate free from sulphur-compounds must, of course, be used.

Within recent years the estimation of sulphur in petroleum has become a far more important analytical operation than it was formerly, in consequence of the increased extent to which crude oils containing sulphur are employed as a source of commercial products. As the result of a lengthy investigation the author has come to the conclusion that the only thoroughly satisfactory process, applicable to all descriptions of petroleum, is that of combustion in oxygen in the Mahler bomb (see p. 751), and determination as barium sulphate. In this way percentage-results concordant to the second place of decimals are readily obtained. It is recommended that 2 grams of the sample should be burned, and that the oxygen should be at a pressure of 30 atmospheres.

**Compound Oils.**—Mineral lubricating oils are frequently mixed with seed oils; "blown" rape oil, or "blown" cotton oil, being in some cases employed to give largely increased viscosity. A small proportion of an animal oil is often added to mineral cylinder-oils. Artificial viscosity is occasionally imparted to some of the less viscous mineral lubricating oils by the addition of aluminium palmitate or oleate. Admixture with rosin oil is also sometimes practised. Fixed oils may be detected, and the proportion determined by difference, by treating the sample with an alcoholic solution of caustic potash, and separating the hydrocarbons from the soap by means of ether, which is afterwards removed by distillation and evaporation. With some descriptions of compound oils, the separation of the hydrocarbons is attended with considerable difficulty, and the author finds that in such cases the extension of the Koettstorfer process

<sup>1</sup> *Proc. Amer. Acad.*, xxxi, 1-66 (1896).

described by Mr. Harold Gripper<sup>1</sup> may be adopted with advantage. The process consists in the saponification of the sample with alcoholic potash solution and titration with hydrochloric acid. It is obvious that unless the nature of the saponifiable oil, and, therefore, its saponification equivalent, is known, the mean of the equivalents of oils likely to be present must be taken, and thus an error may be introduced; but even allowing for this, the author's experience is that the process gives, with some compound oils, more satisfactory results than the method previously described. Besides which the Koettstorfer process may be carried out in the course of an hour, while the other occupies a considerably longer time.

For the detection of fixed oils in mineral oils, Lux's test may be employed. This consists in heating about 5 c.c. of the oil in a test-tube with a small piece of sodium hydrate, the presence of 10 per cent. or more of saponifiable oil being indicated by the solidification of the liquid on cooling. An improvement on this test, described by Mr. James Cameron,<sup>2</sup> consists in heating portions of the sample in two test-tubes in a paraffin bath to a temperature of 200° to 210° C., some shavings of potassium being placed in one tube and a stick of potassium hydrate, standing about 1 centimetre above the surface of the oil, in the other. It is stated that if the mineral oil contains as much as 2 per cent. of fatty oil, the sample is converted into a tough jelly in one of the tubes, and usually in both.

A method employed at Baku for testing the **neutrality** of kerosene is described on p. 757. Mr. Allen recommended that in the case of a lubricating oil, the proportion of free acid, which may be considerable when an animal or vegetable oil has been mixed with a mineral oil, should be determined first in the original oil, by a decinormal solution of caustic soda, using phenolphthalein as an indicator. Another portion of the oil (50 grams), mixed with an equal bulk of water, is then heated in a closed bottle, immersed in water, and frequently agitated. After six or eight hours, the bottle is opened, and the oil and water are separately titrated as above. The acidity of the water will usually be due to free sulphuric acid produced by decomposition of sulphonates in the mineral oil, and if considerable, indicates an inferior oil. The acidity of the oil itself will indicate the amount of fatty acids formed by the heating with water, together with the acids originally present. In the case of cylinder oils, the heating with water may be performed by placing the oil and water in a sealed glass tube, plunged in a boiling saturated solution of calcium chloride. The titration of the aqueous solution is effected in the usual manner, but the oil is treated by the method first proposed by Hausmann. A few drops of an alcoholic solution of phenolphthalein is added to some methylated spirit purified by redistillation, and dilute caustic soda solution is added drop by drop until the liquid retains a faint pink colour. Having thus been freed from acid, from 50 to 100 c.c. of the spirit is poured into a stoppered flask in which a weighed quantity—say 50 grams—of the oil has been placed, and the mixture is heated to the boiling-point with frequent agitation. If the oil contains no free acid, the pink colour will be unchanged; but if the colour disappears, a semi-normal solution of caustic soda (20 grams sodium hydrate in 1 litre of water) is added drop by drop with constant agitation, until the pink colour returns and remains after vigorous shaking. Where only slight acidity is suspected, a decinormal alkali should be used. The acidity is determined by the amount of caustic soda required, but the amount of the acid or acid-producing bodies cannot be precisely determined unless their nature is also known. Thus, 1 c.c.

<sup>1</sup> *Chemical News*, lxx, 27 (1892).

<sup>2</sup> *Oils and Varnishes* (1886), 283, 284.

of the semi-normal alkali corresponds with 0.256 gram of free palmitic acid, but with 0.284 gram of stearic acid.

For the detection of **rosin oil** Allen recommended the addition to a few drops of the sample, dissolved in about 1 c.c. of carbon bisulphide, of a solution of stannic bromide, with excess of bromine, in carbon bisulphide. The production of a fine violet colour indicates the presence of rosin oil. This test is a more delicate modification of that of Renard, who observed that anhydrous stannic chloride produces a violet colour with rosin oil. The stannic bromide is best prepared by allowing bromine to fall drop by drop upon granulated tin contained in a flask immersed in cold water. When the permanent colour indicates the presence of excess of bromine, the product is diluted with three or four times its bulk of carbon bisulphide, in which stannic bromide is soluble. As rosin oil is more soluble than mineral oils in acetic acid, it may be partially separated, and the test rendered more delicate, by agitating the sample in the cold with two volumes of glacial acetic acid, and applying the test to the acid solution. Professor Finkener of the Experimental Institution at Charlottenburg, recommends the use of a mixture of 1 volume of chloroform and 10 volumes of alcohol of 0.818 specific gravity, for separating rosin oil from mineral oils. Ten volumes of this mixture will dissolve, at 23° C., 1 volume of rosin oil, leaving the mineral oil undissolved.

A process for the quantitative separation of rosin oil from mineral oil has been given by Mr. P. C. McIlhiney.<sup>1</sup> It is well known that nitric acid when heated with rosin oil, converts the oil into a brittle red resin, whilst mineral oils are not much affected when similarly treated. The resin was found to be insoluble in petroleum ether, in which the mineral oil readily dissolves. The following method of carrying out the process is recommended:—

Fifty c.c. of nitric acid (specific gravity 1.2) is heated to boiling in a flask of 700 c.c. capacity. The flame is removed, and 5 grams of the oil is dropped in. The flask is then heated on the water-bath, with frequent shaking, for fifteen to twenty minutes, and about 400 c.c. of cold water is added. The contents of the flask having become quite cold, the unchanged mineral oil is next dissolved by shaking with petroleum ether, which is separated and distilled in the usual manner. The residual oil is weighed; and as mineral oils lose about 10 per cent. when treated in this way, the weight obtained divided by 0.9 gives the amount of mineral oil in the quantity taken. A mixture of 76 per cent. mineral oil and 24 per cent. rosin oil gave, by this method, 76.8 per cent. of mineral oil.

The great difference in the solubility of mineral oils and rosin oils in acetone, has been taken advantage of by Demski and Morawski<sup>2</sup> and by Wiederhold,<sup>3</sup> for detecting and roughly estimating adulteration with rosin oil. According to Wiederhold, a Russian spindle-oil of 0.898 specific gravity dissolved in from 40 to 41 volumes of acetone, and an oleonaphtha of 0.908 specific gravity in 70 to 71 volumes, while American spindle-oils were almost insoluble. He applies the test by adding 2 c.c. of the oil to 20 c.c. of acetone in a glass cylinder graduated in tenths of a c.c. After being warmed in a water-bath to 15° C., the liquid is agitated and allowed to settle, and the volume of undissolved oil is read off. The test is, however, a very rough one.

**Mineral burning oils** should bear agitation with an equal volume of sulphuric acid of 1.53 specific gravity without darkening of colour, and warm water which has been shaken with the oil should not exhibit an alkaline or even a

<sup>1</sup> *Journ. Amer. Chem. Soc.*, xvi, 385-388; *Journ. Soc. Chem. Ind.*, xiv, 198 (1895).

<sup>2</sup> *Dingler's polytech. Journ.*, cclviii, 82 (1885).

<sup>3</sup> *Journ. prakt. Chemie*, clv, 394 (1893).



faintly acid reaction, or give any precipitate with barium chloride solution. Phenolphthalein is a more sensitive indicator than litmus, but as a test for acid it is considered by some to be liable to give misleading results when neutral soaps are present, owing to the decomposition of these compounds. Water on being boiled with a **mineral lubricating oil** should remain bright and perfectly neutral. When the oil is agitated in a test-tube with an equal volume of boiling water, and the tube placed in a water-oven until complete separation has taken place, there should be no white film or layer at the junction of the two liquids. On agitation with an equal volume of sulphuric acid of 1.53 specific gravity, the oil should remain undarkened in colour, or should only acquire a yellow tint. The committee appointed by the Baku section of the Imperial Russian Technical Society to examine the Government petroleum-testing regulations, recommended in preference the use of acid of 1.73 specific gravity, 40 volumes of acid to 100 volumes of oil being shaken in a glass-stoppered bottle for two minutes, and the acid layer removed and its colour compared with those of standard solutions of Bismarck brown. When 10 c.c. of the sample is mixed with an equal volume of nitric acid of 1.45 specific gravity, there should be but little rise of temperature.

**Vaseline** should leave no residue when heated in a platinum dish, and the vapour after ignition and extinction of the flame, should have no smell of resin or acrolein. Strong alcohol, on being agitated with the sample, in the proportion of two volumes of the former to one of the latter, and decanted, should exhibit neither an alkaline nor an acid reaction, and should not yield more than a trace of precipitate on dilution with water. On agitation with a cold mixture of sulphuric acid with one-ninth of its weight of water, no marked increase of temperature should occur, and the vaseline should not be much darkened.

According to B. Lach,<sup>1</sup> crude **ozokerite** is best valued as follows:—One hundred grams of the sample is mixed with 20 grams of fuming sulphuric acid in a weighed dish, the mixture being heated to 170° or 180° C. and constantly stirred as long as sulphur dioxide is evolved. The loss is said to represent the petroleum and water, but Mr. Allen points out that the loss of sulphur dioxide and possible loss of sulphur trioxide are not allowed for, and thinks that a better plan would be to dilute the mixture and separate and weigh the paraffin wax. Another test, recommended by Lach, consists in treating 100 grams with 10 grams of the charcoal obtained in the manufacture of potassium ferrocyanide. The charcoal must have been previously dried at 140° C. A portion of the mixture, preferably 11 grams, is then weighed into a weighed filter and extracted with benzene. The loss, or the residue obtained by evaporating the benzene, represents the wax.

The following method of examining **crude shale-oil** was recommended by Mr. R. Tervet:—

“A. One thousand c.c. of crude oil is taken, and, after determination of the specific gravity, is distilled to dryness with the use of steam, the distillate being collected in a separator of large size. A cokey residue is left in the still.

“B. The separator is placed in warm water to bring the distillate (‘once-run oil’) to a temperature of about 40° C. After removing any water that may separate out, the oil is agitated for at least ten minutes with 5 per cent. by volume of sulphuric acid of 1.70 specific gravity, the temperature being kept down by standing the vessel in water at 35° C. When the mixture has settled for about half an hour, the ‘acid tar’ will have separated and may be run off.

“C. The oil from B is washed with 16 to 20 c.c. of soda solution (specific gravity 1.30), and the ‘soda tar’ removed, after settling for half an hour in warm water.

<sup>1</sup> *Chem. Zeit.*, ix, 905 (1885).

"D. This *once purified oil* is then measured and its density ascertained, placed in a fresh still and redistilled to dryness, the distillate being separated into two or more fractions—viz. naphtha (*E*), light oil (*F*), heavy oil (*G*), and still-bottoms (*H*). When the density of the first fraction (which is not obtained at this stage from all crude oils) reaches 0.780, another receiver is substituted, and this serves until a drop, collected from the still-neck on a cool spatula, shows a tendency to solidify, when the second receiver is replaced by a third. When the distillation of the third fraction is drawing to a close, a thick brown or yellow viscid fluid containing chrysene sometimes comes over and is collected separately (*H*), as, if mixed with *G*, it would interfere with the crystallisation of the paraffin scale, and prevent the expression of oil from the scale. It is advisable to mix *H* and *F* together for treatment as below (*I*).

"I. The crude light oil (*F*) is mixed with 2 per cent. of strong sulphuric acid, the acid tar allowed to settle without warming, and after removal, the oil is washed with an excess of soda solution of 1.36 specific gravity and the alkaline solution drawn off. This removes the chrysene existing in *H*.

"J. The washed oil from *I* is measured and its density taken, and is then redistilled to dryness. The distillate is fractionated into three parts as before—viz. naphtha (up to 0.750) (*K*), light oil (*M*), and heavy oil (*N*), the latter being mixed with *G*.

"K. The naphtha is added to the corresponding fraction from the former stage (*E*), and the mixture is measured and its density observed, or, if only a small quantity, it is mixed with the light oil (*M*).

"O. The light oil ('crude burning oil') (*M*) obtained by redistilling *K* is, after addition of fractions *U V*, if any, resulting from the redistillation of the heavy oil, washed with 2 per cent. of acid of specific gravity 1.845 (without any application of heat, for the separation of the 'acid tar'), and agitated with dilute soda solution of specific gravity 1.020 in excess. Its volume and density are noted as the yield of *finished burning oil* (*P*).

"Q. The crude heavy oil (*G*), to which is added the heavy fraction (*N*) from the second distillation of the light oil, is poured out into a shallow flat-bottomed vessel and cooled very gradually, so as to allow the paraffin crystals to properly develop, after which it is further cooled down to about 12° C. The solid cake, wrapped in a linen cloth, of close texture, soaked in oil, is subjected to a light pressure to squeeze out the greater part of the oil, and finally to an increased pressure to remove the remainder, after which the paraffin scale (*R*) is taken out of the cloth and weighed.

"S. The 'blue oil' expressed from the paraffin scale, is washed with 3 per cent. of strong acid and afterwards with an excess of soda solution (sp. gr. 1.33), measured and distilled to dryness, the distillate being divided into three fractions—viz. burning oil (*U*), intermediate oil (*V*), and unfinished lubricating oil (*W*), the first being mixed with *M*.

"V. This intermediate oil is either mixed with *O*, or, if considered advisable, is refined by washing with 2½ per cent. of concentrated sulphuric acid, and subsequently with weak soda solution (sp. gr. 1.020) in excess, and estimated as *finished intermediate oil*. Its density is about 0.850.

"W. The 'unfinished lubricating oil' is refined in the same way by washing with 3 per cent. of acid, specific gravity 1.845, and excess of soda solution (sp. gr. 1.020). The volume and density are recorded as those of *finished lubricating oil*.

"The quantities mentioned in all these processes are volumetric, and the paraffin scale is recorded in the same manner by calculation from the weight. At each stage, the specific gravity and volume of the products should be recorded."

This method of examination, suitably modified, may be adopted with samples of crude petroleum or petroleum residuum. Zaloziecki's method of estimating the **solid hydrocarbons** contained in petroleum, brown-coal oil and other oils, may be described as follows:—The more volatile constituents of the petroleum, etc., are driven off by distillation carried to a temperature of 200° C., and a weighed portion of the residue is mixed with 10 parts by weight of amyl alcohol and 10 parts of 75 per cent. ethyl alcohol. The mixture is cooled for twelve hours at 0° C., and is then filtered cold and washed, first with a mixture of amyl and ethyl alcohols and finally with ethyl alcohol alone. The separated solid paraffin is transferred to a small porcelain evaporating-dish, and dried at 110° C. It is then heated with concentrated sulphuric acid, to 150° to 160° C., for fifteen to thirty minutes, with constant stirring, and the acid having been neutralised, the paraffin is extracted with petroleum ether. After evaporation of the solvent, the paraffin is dried at 100° C., and weighed. In a paper dealing particularly with the examination of brown-coal tar, Mr. R. Höland<sup>1</sup> has given the following *résumé* of the methods of estimating solid hydrocarbons in oils:—

“The paraffin is the most valuable constituent of this substance, and the various oils obtained on distilling it are cooled and pressed most carefully, to extract every possible trace of solid matter. The first pressing takes place at the temperature of spring water—yielding hard paraffin; the second and third are conducted at the ordinary winter temperature, and at an artificially lowered one respectively—yielding softer products; and all the resulting press-cakes and oils have to be tested to determine their commercial value.

“The oldest process for this estimation is Grotowsky's, modified by Engler and Böhm, and consists in dissolving the oil in the smallest possible amount of ether in the cold, and precipitating the paraffins by means of absolute ethyl alcohol. The precipitate is filtered off, washed, and more alcohol added repeatedly until oil begins to be thrown out, and the precipitates must be redissolved and precipitated to free them from oil. Experiments indicate that this process is not sufficiently exact, the paraffins still containing oil and *vice versa*, besides occupying too much time. Pawlewski and Filemonowicz working on petroleum and ozokerite products, precipitate the paraffins from their solutions by adding ten to twenty times their volume of glacial acetic acid, washing the precipitate finally with ethyl alcohol of 75° Tr. This process is useless for brown-coal tar, as the softer paraffins are somewhat soluble in the liquid. Zaloziecki dissolves the oil to be tested in five times its quantity of amyl alcohol and precipitates the paraffins by the addition of the same amount of ethyl alcohol of 75° Tr., keeping the mixture for several hours at a temperature not exceeding 4° C. with occasional agitation, filtering off the precipitate through cold dry paper, and washing with a well-cooled mixture of 2 parts of amyl alcohol and 1 of ethyl alcohol. He then dissolves the paraffins in ether, evaporates the solvent and dries the residue at 125° C. For oils containing little paraffin, he uses ten times the amount of alcohol mixture, and allows it to stand ten to twelve hours. Modified somewhat to suit the brown coal-tar products, this process has only the disadvantage attending the use of such a high temperature for drying, besides the unpleasantness of the operation.

“While ethyl alcohol of not more than 98 per cent. strength only yields turbid solutions with brown coal-tar oils, 99.5 to 100 per cent. alcohol dissolves these oils, when free from paraffin, up to the specific gravity 0.850 in all proportions; from 0.850 to 0.880 they require five times, and from 0.880 upwards

<sup>1</sup> *Chem. Zeit.*, xvii, 1473 and 1483 (1893); *Journ. Soc. Chem. Ind.*, xiii, 286 (1894).

ten times their weight of solvent, and all the solutions may be cooled to the ordinary laboratory temperature without any separation taking place. On the other hand, paraffin of 60° C. melting-point, when boiled with alcohol, separates out almost completely when the liquid is cooled to 25° C., and at 0° C. it is absolutely insoluble. Softer paraffins are more soluble as their melting-point falls, but even that melting at 34° is absolutely insoluble in alcohol at 0°.

“A number of experiments carried out on various known mixtures of paraffins and paraffin-free oils, by dissolving 20 grams of the substance in 100 c.c. of absolute ethyl alcohol, cooling the solution for two hours in melting ice, and filtering through a double filter, gave very satisfactory results; the extracted paraffins having within a degree or two the same melting-point as the original, and the oils on distillation furnishing, up to the very last, distillates which remained liquid when allowed to fall on a piece of ice.”

Full particulars of Holde's method of carrying out the alcohol-ether process of separation, with a drawing of the apparatus employed, will be found in the *Journal of the Society of Chemical Industry*, xvi (1897), 362.

The composition and properties of asphalt and asphalt-rock have been given in Section III (pp. 331–337 *et seq.*). In Spon's *Encyclopædia* it is stated that asphalt for varnish-making should dissolve wholly, or with the exception of 4 or 5 per cent. of earthy matter, in carbon bisulphide, chloroform, oil of turpentine, or coal-tar naphtha of high boiling-point. It should have a conchoidal fracture and brilliant lustre, and should yield a light brown powder. An angular fragment should not lose its shape, even at the edges, in boiling water, and should only begin to melt at 150° C. When adulterated with coal-tar pitch, the asphalt has a less brilliant fracture, and has an adamantine or metallic lustre instead of the ordinary resinous appearance. When fused at the lowest possible temperature, such adulterated asphalt has a granular pasty appearance and feeling, and will not draw out into even and transparent brown threads, as pure asphalt does.

W. H. Delano<sup>1</sup> states that bitumen for mixing with asphalt-rock should be perfectly black, “not brilliant,” and at 70° F. should have the consistency of beeswax. “The best way to test the quality is to draw it out in threads; the longer they stretch the better the sample.”

**Dow Penetration Test.**—This test is designed to indicate the relative consistencies of asphalts, cements, etc. The machine employed for the test consists essentially of a substantial base on which the sample is placed, and a light movable framework in which is fixed a No. 2 needle and which, by means of a rack, works a pointer across a dial-indicator. Samples are placed in small tins and are tested at a temperature of 77° F. (25° C.), the needle, weighted to 50 G. or 100 G., being allowed to penetrate the sample for five seconds. By means of a clamp the penetration is then arrested and the reading on the dial is noted. One division on the dial indicates a movement of the rack of 0.01 cm.

The physical characters of bitumen from Trinidad and Bermudez (Venezuela) at different temperatures have been given as follows:—

TABLE CXLIX.—BITUMENS OF TRINIDAD AND VENEZUELA.

	Trinidad Bitumen.	Bermudez Bitumen.
At 60° F., .	Hard and brittle.	Compressible.
„ 75° „ .	Can be slightly bent.	Viscous and malleable.
„ 100° „ .	Does not flow, but is easily bent.	Flowing, and can be drawn out into hair-like threads.
„ 189° „ .	Flowing-point.	Fluid.

<sup>1</sup> *Twenty Years' Practical Experience of Natural Asphalt*, 1893.

Durand-Clay has proposed the following process for distinguishing between natural asphalt and coal-tar pitch :—

Five c.c. of petroleum spirit is added to 1 gram of the sample and shaken up repeatedly. Filter, and add sufficient petroleum spirit to 5 or 6 drops of the filtrate to make up 5 c.c. Coal-tar pitch produces a greenish fluorescence which is seldom observed in specimens of mineral asphalt, and a similar fluorescence is imparted by the former to its solution in glacial acetic acid, turpentine, or chloroform. After shaking up with an equal bulk of rectified spirit, the mixture is allowed to settle, when the petroleum spirit, strongly coloured, will float on the top, the lower layer of alcohol being golden yellow in the case of coal-tar pitch, whilst, if the sample consists of natural asphalt, it will be either colourless or pale straw-yellow. If much volatile oil is present, the alcohol will be of a rather darker yellow than otherwise. A preferable test, proposed by the same author, consists in digesting the sample in carbon bisulphide, filtering the solution, evaporating the filtrate to dryness, and heating the residue until it becomes hard and brittle when cooled. To 0.1 gram of this residue, in a stoppered tube, add 5 c.c. of fuming sulphuric acid, agitate, and allow to stand for twenty-four hours. Then add 10 c.c. of water, one drop at a time, with continual stirring, and filter through paper. Natural bitumen gives no colouration or only a faint tinge, while coal-tar pitch gives a dark brown colour. If both are present, the proportions can be approximately determined by observing the depth of the shade produced (viewed by transmitted light).

C. Kingzett's process for determining the total amount of bituminous matter in asphalt-rock and mixtures in which it is contained, consists in extracting the air-dried sample by means of freshly prepared Russian oil of turpentine, evaporating the solution, and weighing the residue. The insoluble matter is washed with ether, and the siliceous matter remaining after dissolving out the carbonates of magnesium and calcium with diluted hydrochloric acid is washed and weighed. H. P. Cooper uses carbon bisulphide as the extracting agent. This solvent so completely removes the bitumen from Val de Travers asphalt, even when used in the cold, that the limestone residue is quite white. A good way to perform this test is to exhaust 20 grams of the powdered sample with carbon bisulphide in a Soxhlet tube. If a correction is made for the water driven off at 100° C., the bituminous matter is indicated by the loss of weight. To verify the estimation, the carbon bisulphide can be distilled off and the residue heated to 100° C. until the weight is constant. To ascertain whether the sample is of good quality, the bitumen should be then heated to 220° C., the loss in weight being volatile oil ("petroleum"). This oil can also be determined in a better way by digesting the powdered sample repeatedly with cold alcohol until no turbidity is produced in the solvent by the addition of water, and weighing the residue. The carbon bisulphide should contain no free sulphur. Chloroform or benzene (coal-tar naphtha) may also be employed. A dark-coloured residue, after extraction of the bitumen, indicates the presence of useless organic matter, the amount of which is ascertained by ignition of the weighed residue, recarbonating with ammonium carbonate, re-igniting gently, and weighing. The loss indicates non-bituminous organic matter. When the residue is white, the bitumen may be determined by simple ignition, recarbonating the lime, and weighing.

Miss Linton<sup>1</sup> recommends the following method of analysing asphalt :—

"Water is first to be determined, if present, by drying in a water-oven to a constant weight. The finely-powdered sample,  $\frac{1}{2}$  gram if rich in bituminous matter, several grams if rich in mineral constituents, is digested overnight, in

<sup>1</sup> *Journ. Amer. Chem. Soc.*, xvi, 809-822 (1894); xviii, 275-283 (1896).

a 4-ounce Erlenmeyer flask, with 50 c.c. of petroleum ether. The solution is decanted on to a weighed filter contained in a 3-inch funnel having a tap in the spout. The residue in the flask is digested for two or three hours with fresh petroleum ether, which is decanted as before, and this process is continued as long as any colour comes away. Then the insoluble residue is transferred to the filter, dried and weighed, any traces adhering to the flask being estimated by weighing the flask. The portion dissolved by the petroleum ether is put down as 'petrolene.' The flask is rinsed with boiling turpentine, which is poured on the filter (replaced in the funnel), and enough boiling turpentine is poured on the filter to wholly submerge it, left to digest for several hours or overnight, and then allowed to filter through. The digestion with boiling turpentine and filtering is continued as long as any colour comes away, and then the process is repeated with chloroform; after which the filter is again dried and weighed, and the loss is entered as 'asphaltene.' The filter is now burned with the contents, the ash is treated with ammonium carbonate to restore  $\text{CO}_2$  to any lime which may have been formed, and the loss of weight is put down as 'other organic matter,' the remainder being 'mineral matter.' "

## SECTION X.

### THE USES OF PETROLEUM AND ITS PRODUCTS.

**General Review.**—In the first section of this work it was mentioned that petroleum and natural gas have been employed in a primitive manner as sources of light and heat from the earliest times, and that the use of the crude oil for the treatment of wounds and cutaneous affections, while at least of equal antiquity, has been even more general. The latter application may indeed be said to have been at one time universal, for it appears from the accounts given by historians that, as a remedial agent, petroleum was carried to distant countries from the localities where it was found, and was thus a not unimportant article of commerce.

For *pharmaceutical purposes* crude petroleum is no longer in general use by civilised races, but a specially purified tasteless paraffin oil distillate is commonly employed for internal use, and the product *vaseline*, *paraffinum molle*, British Pharmacopœia, is very largely employed, both alone and as a vehicle for the external application of medicinal agents, especially when local action, rather than absorption, is desired. The physical and chemical characters of vaseline, which have been described in a previous section, indicate the superiority of this product over an animal fat for such purposes. In the British Pharmacopœia (1908) a reddish-brown syrupy liquid, with igneous bituminous odour and taste, is described, under the name of *ichthyol* (ammonium ichthyol-sulphonate), as being obtained by the action of sulphuric acid on a sulphur-containing mineral oil distilled from peculiar fossil deposits. It is used, both internally and externally, for chronic eczema, psoriasis, chronic rheumatism, etc.

Vaseline forms a good protective coating for the surface of oxidisable metal, and as such is used to a very considerable extent.

The volatile product of petroleum termed *rhigolene* has been found to be a valuable *anæsthetic*, particularly for local application to produce cold.

The *paraffin candle* has so completely superseded the old tallow "dip," and the beautiful translucent candles of white paraffin are so commonly employed, that it is unnecessary to point out how important the solid hydrocarbons contained in petroleum and shale oil have become to the candlemaker. Paraffin of low fusing-point is also burned in specially constructed lamps.

As *illuminating agents* the liquid products of petroleum are used under various conditions. The most important of these products, commercially, is kerosene, but both the more volatile and the less volatile are also largely employed in suitable lamps. Petroleum products and crude petroleum constitute an important source of light in their employment for (1) the production of "*air-gas*" or *carburetted air*, (2) the manufacture of *oil-gas* and *carburetted water-gas*, and (3) the *enrichment of coal-gas*. For the first of these purposes gasoline is needed; for the second, crude petroleum, various petroleum products, and shale oil distillates are available—the liquid hydrocarbons

being converted into permanent gas of high illuminating power ; while for the third, either oil-gas or the vapour of the sufficiently volatile hydrocarbons is required.

The *petroleum stoves* employed in this country for heating and cooking are practically lamps of suitable construction in which mineral oil is burned, with either luminous or non-luminous (smokeless) flames.

*Petroleum residuum* and the heavier distilled petroleum oils have very widely replaced solid fuel on steamships, in locomotives, and in stationary boilers, as well as for various industrial operations. In the United States *natural gas* and *crude petroleum* are largely employed as fuel.

Petroleum products also constitute an important *source of power* in connection with motors of the gas-engine type, and the use of these in most forms of autocar and for aviation has created an enormous demand for petroleum spirit. The introduction of engines of the Diesel and semi-Diesel type, in which heavy oils and even crude petroleum are used, has largely extended the scope of application of petroleum as a source of power.

The very general and increasing substitution of mineral oils for fixed oils and greases in the *lubrication* of machinery and the rolling-stock of railways indicates the importance of this application of petroleum products. For some purposes preference is still given to "compound oils," which are mixtures of mineral and fixed oils, but for the lubrication of steam-engine cylinders a pure hydrocarbon oil, or at any rate a mineral oil with a very small admixture of a fixed oil, should always be used, as in the presence of high-pressure steam fixed oils are decomposed, with the production of free fatty acids and subsequent formation of metallic soaps.

The more viscous descriptions of mineral oils have been found specially suited for use in the Elmore process of *ore-concentration* by oil.

The employment of petroleum products in obtaining light, heat, and motive power, and for other of the more important uses, will be discussed in some detail in the following pages, but in order to complete this general review of the subject, reference will first be made to some of the less important applications of certain products.

Paraffin is used in the manufacture of wooden matches in the place of sulphur, the combustibility of the wood being increased by saturating it with the melted material, and it has been applied as a thin coating to the heads of matches to render them waterproof. Dr. Stenhouse has patented the application of paraffin to woollen fabrics to impart additional strength and render them waterproof. In Java, paraffin is employed by manufacturers of coloured textile materials in tracing designs on the fabric before it is immersed in the dye. It has been used for lining beer-barrels, and is employed for glazing frescoes and paper, for saturating gypsum and fluorspar before turning them in the lathe or otherwise shaping them into ornaments, and in starching linen to produce a gloss. Of recent years, paraffin, as well as mineral oil, has been used in laundry work, as an auxiliary to soap, on account of its detergent action. Paraffin is also employed as a preservative for stone and wood, and it forms a good protective coating for the labels and stoppers of bottles used for corrosive liquids. It is used in preserving eggs, and may be similarly applied as a preservative coating to other perishable articles. Refined ozokerite is employed by French perfumers as a substitute for lard in the process known as "en-fleurage," the almost entire solubility of the hydrocarbon in alcohol, and its non-liability to become rancid, giving it a great advantage over the animal fat. Paraffin-wax forms an excellent electric insulator, and a good photometer disc-substitute may be made by placing a sheet of tinfoil between two suitably-



shaped blocks of paraffin. The author has made use of this device, and can express a favourable opinion of it.

High-flashing distillates also find wide application as an insulating medium in transformer oils.

In 1892 Chenhall and Chenhall patented a process for the "solidification" of petroleum by means of resin soap. By heating together a mixture of a suitable description of petroleum with resin and caustic soda, a solid compound was obtained which contained about 75 per cent. of petroleum and burned without liquefying.

The process patented by J. W. Leadbeater (1897) consisted in mixing together, with as little heat as possible, and in approximately the following proportions, which have to be varied according to the consistency required in the product:—petroleum, crude or otherwise (including ostatki), 128 parts; animal and vegetable stearin, 1 part; resin, 12 parts; unslaked lime, 8 parts; and sawdust, 8 parts. The water needed for the chemical reaction, which is accompanied by considerable rise of temperature when the process is carried out on a sufficiently large scale, is apparently derived from the sawdust. For the manufacture of briquettes, 5 to 10 per cent. of the petroleum-product, prepared as already described, is mixed with coal-dust or other combustible material, with the addition of an agglutinant, such as pitch.

The "solidifying" action on petroleum of a decoction of the bark of *Quillaja saponaria* was pointed out in 1875 by Morgan-Brown, who, in that year, patented a process based upon it. The similar employment of an extract of a lichen, such as Japanese, Chinese, or Corsican moss, was patented in 1879, and among other solidifying agents since then proposed are fish-glue and casein.

A process of "solidifying" petroleum, which was patented in this country by Dr. Thomas van der Heyden (No. 10,797 of 1904), consists in forming an emulsion of the oil with a warm solution of glue, allowing the mixture to cool in moulds, when it forms solid blocks, and then hardening the glue by means of formaldehyde.

During the year 1911 considerable publicity was given in the press to the invention by Mr. J. Tarbotton Armstrong of a process for the conversion of petroleum into a solid, suitable for use as fuel and for other purposes. In this process glue was employed with a solution of iron sulphate as a hardening agent, and five patents (Nos. 868, 869, 10,119, 18,300, and 21,059 of 1911) were granted to J. T. Armstrong and J. Morgan.

In 1894 Weygang patented in this country a process for obtaining a petroleum product miscible with, or soluble in, water, and subsequently obtained patents for his invention in Germany and the United States. The process substantially consisted in the production of a clear oleaginous liquid by the partial saponification of resin previously dissolved in petroleum, only about one-half of the resin acid present being combined with the alkali employed, and the resin soap thus formed being rendered soluble in the petroleum, in which it would not otherwise dissolve, by the presence of the unsaponified resin. From this primary product the inventor obtained (1) a "siccative oil" by treatment with a drier, (2) a turpentine substitute, (3) a "soluble solid oil" suitable for use in soap-making, (4) a "soluble semi-solid, or liquid oil" for employment as an insecticide, or as a sheep-wash, or in the dressing of wool and fibres generally, (5) "lubricating oils and creams," (6) "refined miscible oil, more or less inodorous, from which various medicinal and toilet preparations are made," and (7) "residues, some of which form the basis of colours applicable in the manufacture of printing inks." Weygang also patented the use of the "soluble oil" in admixture with water as liquid fuel.

In carrying out one form of the process patented by Boleg in 1899 for rendering mineral oils soluble in, or readily emulsifiable with, water, air was blown through a mixture of resin oil and caustic-soda solution, heated to 75° or 80° C., until the product on cooling became a jelly-like mass, and this product, together with an aqueous solution of a fatty-oil soap, was mixed with mineral lubricating oil. The product thus obtained is intended to be employed, in admixture with water, as a lubricant for machinery, and its lubricating properties were reported to have been tested in the Mechanico-Technical Laboratory at Charlottenburg, and elsewhere, with satisfactory results. Boleg's "soluble oils" are also claimed to be applicable with great advantage in the lubrication of the tools used in boring and cutting metals, in the polishing of metallic surfaces, in the oiling of wool and other fibres, in the colouring and glazing of tiles and bricks, in the oiling of leather, and in the manufacture of soaps, perfumes, disinfectants, and various pharmaceutical preparations.

In 1903 Westrum patented the use of a "soluble oil," such as that of Boleg, in admixture with a large quantity of water, for the sprinkling of roads with the object of "laying" dust. Many stretches of road were treated with "Westrumite," as the product was termed, especially in connection with motor-car races, and the "laying" of the dust was found to be thus effected with greater permanence than by the employment of water, the presence of the oil apparently arresting evaporation.

Petroleum has for many years been largely introduced into soaps for household use on account of its detergent properties. It is also employed in association with soap in the manufacture of lubricating greases and insecticides.

A substitute for oil of turpentine for mixing with varnishes and paints is obtained from petroleum spirit by fractionation, and it has been found that other, less volatile, products of petroleum can also be used successfully in the preparation of paints. Petroleum distillates are sold under the names of "Patent Turpentine," (Patent 1885, No. 12,239), "Turpenteen," and "English Turpentine," for use in mixing paints. Samples of these products, examined by the author, were found to resemble oil of turpentine in boiling-point, and to have flashing-points above 73° F. (Abel test).

Certain descriptions of solid bitumen, occurring in Kansas and elsewhere in the United States, dissolve completely in a suitable solvent, and the varnish thus formed, when applied to wood or metal, gives a hard, and yet sufficiently elastic, protective coating with a brilliant surface.

Petroleum spirit is largely used in the process of "dry-cleaning," and in the extraction of grease from leather. It is also employed by floor-cloth manufacturers, and as a solvent in other industries.

The domestic use of petrol as a detergent, except on a very small scale, should be discouraged. The facility with which petrol, intended only to be employed in motor-cars, can now be obtained, has led to the dangerous practice of cleaning garments in the dwelling-house with this highly volatile and inflammable liquid. Apart from the risk of fire, cases have occurred in which death by asphyxiation caused by inhaling the vapour has been narrowly escaped, and the lives of those who work in the sewers have been endangered by explosions ascribed to petrol, which had been used for the purpose referred to, having been got rid of by pouring it into the house-drains. Another dangerous and sometimes fatal practice is the use of petroleum spirit for cleansing the hair.

A process for the purification of alcohol by means of hydrocarbons was described by Dr. Squire in a paper read before the Society of Chemical Industry.<sup>1</sup>

<sup>1</sup> *Journ. Soc. Chem. Ind.*, viii, 441 (1889).

Oils and fats possess the property of absorbing the more or less volatile bodies which impart a characteristic odour to substances, and this property has been taken advantage of in the present process. Parsons, of New York, in 1869, took out a patent for the purification of alcohol—90 per cent. at least—with paraffin, the mixture being heated by means of a steam-coil with continued agitation. Warm water was then introduced so as to bring the mixture down to about 50 per cent. of alcohol, and the whole allowed to cool, with continued agitation. The paraffin, which separated in flakes, was then filtered off from the purified spirit. In 1884 the subject was taken up by a Danish chemist named Bang, who became associated with M. Ruffin, of Paris. He pointed out that the fusel oil could be more effectively separated if dilute spirit were employed, and proposed the use of a volatile liquid product of petroleum as the purifying agent. Ultimately, however, a petroleum product of higher boiling-point was found preferable. The details of the apparatus employed in carrying out the process on a commercial scale, and of a modified form devised in 1887 by Bowick, are given in the paper above referred to. The process was investigated in 1889 by Messrs. Newlands Brothers, to whom the author is indebted for the information that ordinary petroleum having a boiling-point of 140° C. was used, and that the quality of the crude spirit (manufactured from molasses) was found to be very much improved by the treatment.

### SWITCH AND TRANSFORMER OILS.<sup>1</sup>

The operation of any modern power-station of even moderate size is, apart from the lubrication of machinery, dependent upon the utilisation of mineral oil of high quality, primarily as an electrical insulator and conductor of heat in static transformers, and secondarily for the purpose of quenching arcs in high-tension switch-gear.

While it is entirely feasible to design air-cooled transformers for working pressures up to, say, 10,000 volts, consideration of space and the need to improve and maintain a high-insulation value have led to the supersession of the air-cooled transformer. At the time of writing, the best modern practice is to use oil-cooled transformers even for such small transformers as those of 5 kilowatts capacity on 440- and 500-volt alternating current circuits.

*Oil-Cooling.*—The practice of different designers varies greatly as to the volume of oil used in any transformer of any given size, and is dependent upon (1) the heat-radiating surface from the core plates and coils to the oil; (2) the heat-radiating surface of the transformer to the surrounding air, and (3) the efficiency of natural circulation of the oil within the transformer case.

Both British and American makers have often supplemented the cooling due to heat radiation from the transformer case by using cooling coils placed at the top of the oil through which water is pumped. A better practice was that more largely used by Continental makers of cooling the oil externally by pumping the oil through pipes immersed in water. The circulation within the transformer can be improved, temperature can be closely controlled and the volume of oil in use reduced.

<sup>1</sup> Contributed by Mr. W. Pollard Digby.

The following articles and papers should be consulted:—"Physical Properties of Switch and Transformer Oils," W. Pollard Digby and D. B. Mellis (*Journ. Inst. Elec. Engrs.*, 1910, xlv, 165); "The Formation of Deposits in Oil-Cooled Transformers," A. C. Michie (*loc. cit.*, 1913, li, 222); "Reports International Congress of Applied Chemistry, 1913" (see *Journ. Soc. Chem. Ind.*, 1913, xxxii, 62-72); "Research Committee Reports, Institution of Electrical Engineers" (*Journ. Inst. Elec. Engrs.*, 1915, liii, 146, and 1916, liv, 497).

Initially in using oil as a cooling and insulating medium, the only factors receiving attention were (1) flash-point, (2) viscosity, (3) dielectric strength. Experience has shown the need of specifying other properties, and standard specifications with the general adoption of standardised methods of testing may be looked for as the result of the work of the Insulating Oils Research Committee of the Institution of Electrical Engineers. As instancing the need for such a research, mention may be made of the need to define the rate of thermal transference in unit quantity in unit time. The rate of thermal transference is not in practice the equivalent of thermal conductivity on account of the variation in the viscosity with the temperature of the oil and also of the effect of convection currents within the oil when used in a transformer.

*Flash-Point.*—It is very rare, indeed, for it to be necessary to seek an oil having a higher flash-point than  $175^{\circ}$  to  $180^{\circ}$  C. as measured in the Pensky-Marten apparatus.

Colourless mineral oils having a flash-point as low as  $125^{\circ}$  to  $130^{\circ}$  C. have been extensively used in North America, but are not suitable for use in tropical countries.

As a general rule, the flash-point should be from  $60^{\circ}$  to  $70^{\circ}$  C. above the working temperature of the transformer room plus the rise in temperature of the oil when the transformer is at full load and the rate of radiation of heat exactly balances the heat given to the oil.

Temperature measurements in oil-cooled transformers are very often misleading except where thermo-couples are used intelligently. Measurements calculated from the increase of electrical resistance of the windings give a mean value only—part of the windings are in cool oil at the bottom of the tanks, part in hotter oil at the top of the tanks. What is of vital consequence is the temperature which may be reached at certain hot spots where the natural circulation of the oil is either impeded or stopped altogether. The alternative workshop conventional practice of measuring the temperature of the oil at the top of the transformer and describing that as the maximum temperature rise under any given conditions of load is scientifically unsound, as obviously thin films of the oil have been in contact with surfaces hotter than the oil at the surface where it is mixed with oil from cooler portions.

*Viscosity and Specific Gravity.*—Except as indicating the source (when stated in conjunction with the other physical properties) it is not necessary, although usual, to specify these. Given equality in other respects, oils having low viscosity are preferable for transformers, but in considering this factor regard should be given to the viscosity-temperature curves. Oils differing widely at atmospheric temperatures have closely similar values at ordinary working temperatures.

*Sludge.*—The expression “sludging” is used to describe the tendency of certain insulating oils to form solid deposits due to the combined action of heat and air. Such deposits adhere to the windings and retard the circulation, thus leading to overheating. Dr. A. C. Michie has shown that with any given volume of air (or oxygen) passed through, the tendency to “sludge” is very largely increased by the presence of bare copper acting catalytically.

In general, the darker the oil the greater the tendency to form sludge; relative change of colour on heating is a rough indication of the value of an oil in this respect.

*Dryness of Oil.*—An oil containing traces of moisture is fatal to the operation of any high-tension transformer as occasioning short circuits between the windings. Chemical tests with desiccated copper sulphate are qualitative rather than quantitative. Some makers are content with a high dielectric

test figure. This only discriminates to a small degree, and closer indications, although only inferentially quantitative, can be obtained by measurements of specific resistance. When an oil is found to be wet, drying at 90° to 95° C. in vacuo is the only safe remedy. Drying at higher temperatures in air, as is sometimes done, is to be strongly deprecated as tending to cause alterations to specific gravity and viscosity through fractional evaporation.

*Dielectric Strength and Specific Resistance.*—The breakdown voltage of a dielectric strength test is regarded as an indication of the amount of moisture present in the oil. The methods of conducting this test are being standardised, but the results need study in connection with quantitative determinations of the amount of moisture present. The relation between specific resistance and dielectric strength requires study. It seems probable that the specific resistance tests will be a better indication of the dryness of the oil than dielectric strength test.

The leading properties of a number of transformer oils in common use prior to and since 1914 are set out below:—

TABLE CL.

No.	Specific Gravity.	Viscosity. <sup>1</sup>	Flash-point, °C.	Specific Resistance, megohms per c.c.
1	0·8563	27·63	176·2	6,500,000
2	0·8634	44·09	166·5	666,000
3	0·9030	87·98	181·0	6,500,000
4	0·8936	56·26	180·0	1,864,000
5	0·8936	38·30	182·2	1,540,000
6	0·8823	34·32	142·0	2,618,000
7	0·8570	27·22	169·0	6,000,000
8	0·8780	32·10	146·5	6,000,000
9	0·8840	39·00	169·0	...
10	0·8590	30·00	180·0	...

A sub-committee of the Institution of Electrical Engineers is dealing with the whole subject of the properties of switch and transformer oils, and is engaged on the standardisation of methods of testing, both physical and chemical. References to the preliminary report and recommendations of the sub-committee are given on p. 887.

### MINERAL-OIL LAMPS.

The various forms of lamps in which mineral oils are burned generally resemble those previously in use with fixed oils, but certain modifications have been rendered necessary by the comparative volatility and inflammability of mineral oils, and the high percentage of carbon which they contain. Thus it is necessary to guard against any considerable heating of the bulk of the oil, and especially against the ignition of any inflammable or explosive mixture of petroleum-vapour and air which may be formed in the upper part of the lamp reservoir, whilst at the same time the illuminant must be continuously supplied in proper quantities to the flame, and the air admitted in such a manner as to produce a smokeless and odourless flame of high illuminating power. Special appliances are also usually provided to facilitate the lighting

<sup>1</sup> At 15° C. compared with rape oil as 100.

and extinguishing of the lamp, and in some cases the lamp is fitted with an automatic extinguisher, which is brought into action in the event of the lamp being overturned.

In this country the lamps first used with shale-oil were those which had been constructed for burning "camphine" (rectified oil of turpentine). The best of the camphine lamps is said to have been Roberts' "Gem" lamp, which was on the Argand principle, and was fitted with the disc air-deflector known as the "Liverpool button." Mineral-oil lamps were originally introduced into the United States from Vienna, but in 1859 as many as forty patents were granted in America for petroleum lamps and burners and appliances in connection therewith. In 1852 or 1853 Stobwasser of Berlin introduced an Argand

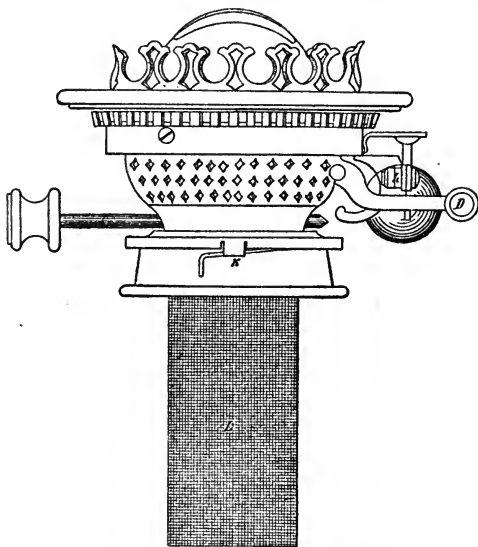

FIG. 288.—HINKS'S DUPLEX BURNER.

burner for use with coal-oil, and a flat-wick burner for the oil obtained from lignite. The latter form of burner was adopted by Young's Paraffin Light and Mineral Oil Company for burning shale-oil.

In 1865 J. & J. Hinks obtained a patent for their "Duplex burner," shown in figs. 288 to 290, and in a slightly modified form, representing the more recent construction, in fig. 291. In the patent specification the wick-holders are described as being of flat, semi-cylindrical, elliptical, or other shape. The burner is now fitted with an arrangement for raising the chimney-gallery to facilitate lighting. The lifting is effected by turning a key, A, which acts through links, *a*, steadiness being secured by means of two guide-rods, B. The burner is provided with an automatic extinguisher consisting of two plates, *d e*, which slide on the wick-holders, C, and are brought together by a spring, E, acting through a forked lever, D, when a catch, *h*, is released. The automatic arrangement comprises a weight, F, hanging in a ring, *g*, on a lever

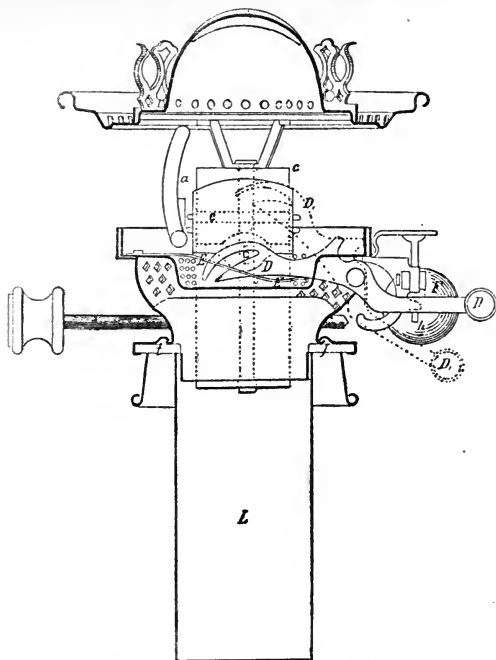

FIG. 289.—HINKS'S DUPLEX BURNER.

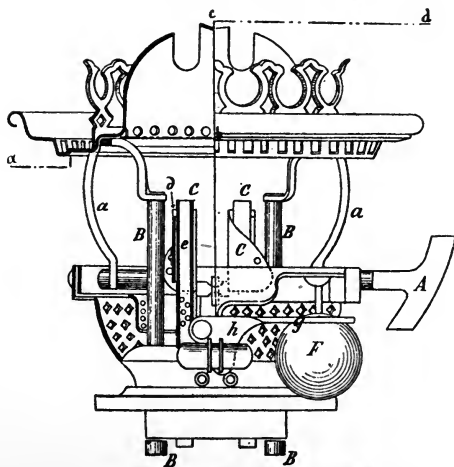

FIG. 290.—HINKS'S DUPLEX BURNER.

carrying the catch, *h*, and is set for use by depressing the lever until the catch is engaged. In case the lamp becomes overturned or much tilted, the alteration produced in the relative positions of the weight and the ring, *g*, releases the catch, and the plates, *d e*, extinguish the light. Extinction may also be effected by pressing down the outer end of the lever, *D* (figs. 288 and 289), or in the arrangement shown in fig. 290, by moving the weight. The burner is secured by a bayonet catch, *K*, and a ring of cork, *J*, is interposed between it and the reservoir to minimise conduction of heat. The "safety-cage," *L*, surrounding the wick, is referred to on p. 903.

In the "Anucapnic" burner, patented in 1866 by T. Rowatt (No. 203), two distinct air-currents are directed upon the flame without the aid of the ordinary chimney, by means of two cones or deflectors, *d f* (fig. 292), the outer

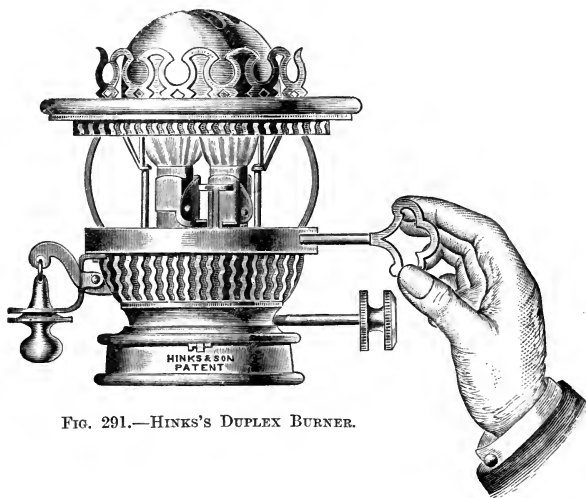

FIG. 291.—HINK'S DUPLEX BURNER.

of which rests on the perforated flange of the inner. Air is supplied to the inner cone through apertures, *e*, in its support, *b*. Fig. 293 shows Rowatt's "Lorne" burner (also used without a chimney), in which the wick tubes are so inclined that the flames coalesce, the wicks being in contact below the burner. This arrangement is said to result in increased luminosity and enhanced capillary attraction in the wicks.

The "Defries" lamp (fig. 294), patented by Sepulchre (1881, No. 5428), has a tubular wick passing between two concentric tubes, the outer of which is attached to the removable burner, and extends nearly to the bottom of the oil-container, while the inner passes through the bottom of the oil-container, and conveys air, through the burner, to the inner surface of the Argand flame. The outer tube serves to prevent outflow of oil in case the lamp is overturned. The burner is provided with an elongated air-diffuser, *A*, fitting into the inner air tube. The wick-adjusting mechanism is contained in a chamber screwing tightly into a concave receptacle, *D*.

In the "Lampe Belge" there is also a central air-tube passing through the



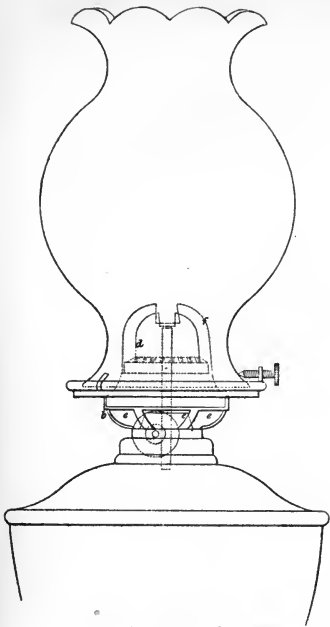

FIG. 292.—ANUCAPNIC BURNER.

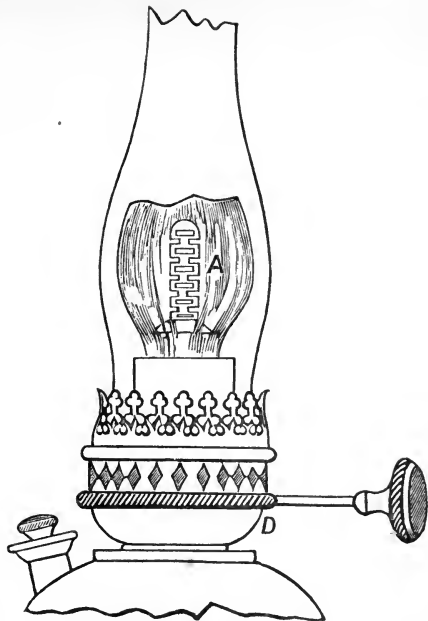

FIG. 294.—SEPULCHRE BURNER.

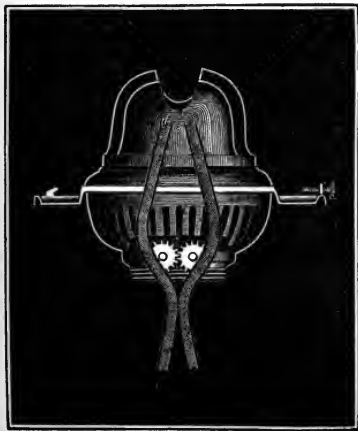

FIG. 293.—LORNE BURNER.

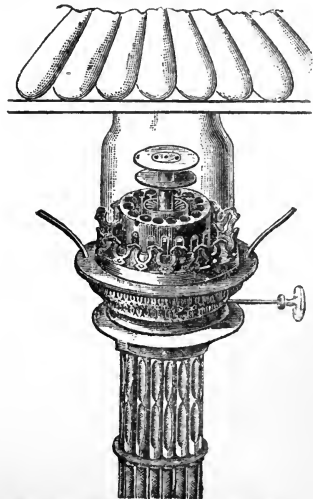

FIG. 295.—MITRAILLEUSE BURNER.

oil reservoir, and an improved arrangement for raising and lowering the wick is provided.

Fig. 295 represents the "Mitrailleuse" burner, patented by Rettich. It has a number of solid cylindrical wicks arranged in a circle, so that they may

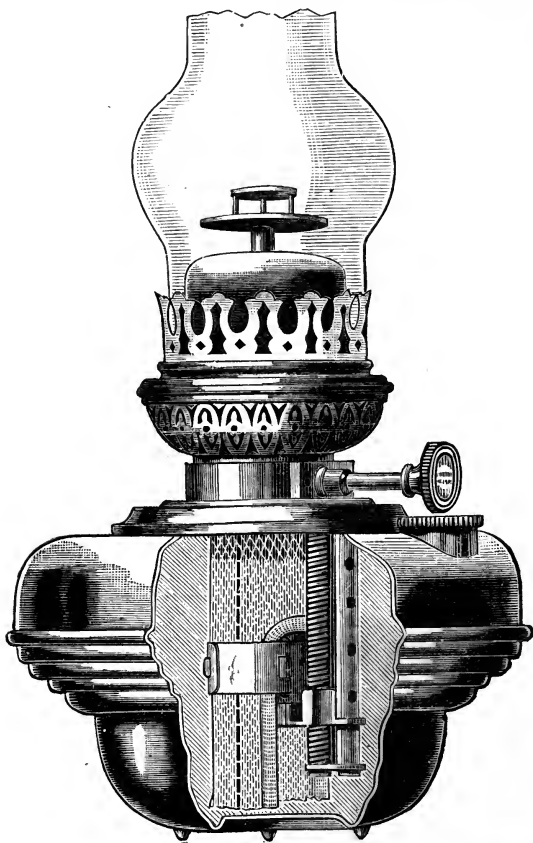

FIG. 296.—LAMPE VERITAS.

be adjusted simultaneously by one winder, and cannot be turned down so far as to drop into the reservoir. A double-disc air-diffuser is employed, and an arrangement for raising the chimney-gallery to facilitate lighting is provided.

The "Lampe Veritas" is fitted with the air-diffuser and wick-raising mechanism illustrated in fig. 296.

In the "Rochester" lamp (fig. 297) air is supplied to the inner surface of the Argand flame through a perforated tubular cap fitted outside the top of

the air-tube. The wick is attached to a tubular holder, and is adjusted by means of a rod, as shown in the figure.

In the Wanzer lamp, which is used without a chimney, the necessary current of air is furnished by a small fan driven by clock-work.

Fig. 298 represents the lamp patented by Aria (No. 15,768 of 1888), in which the oil is supplied from an upper reservoir as in an ordinary reading or railway-roof lamp, or from a lower reservoir by a pump or piston as in the Carcel or Moderator lamp. A

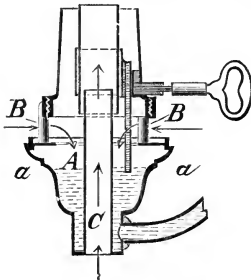

FIG. 298.—ARIA LAMP.

flange, *a*, in the reservoir, *A*, prevents overflow from the shaking of the lamp. A skeleton frame, *B*, supports the burner above the reservoir, and a tube, *C*, supplies air to the centre of the Argand flame.

A flat-wick burner, patented by Aria (No. 8995 of 1890), has a perforated annulus instead of the skeleton frame, and the air-supply is delivered through two semi-cylindrical tubes, the lower ends of which are covered by a cap with a slot which may be more or less closed to regulate the admission of air to the tubes.

In the "Sunlight" lamp (figs. 299 and 300) of Ross and Atkins (Patent No. 2019 of 1889), the principle of the inverted Argand burner so largely employed in the case of gas-lamps is adopted. The wick usually consists of an annulus of solid cylindrical wick supplied with oil by three flat wicks, or by a number of separate round wicks



FIG. 297.—ROCHESTER LAMP.

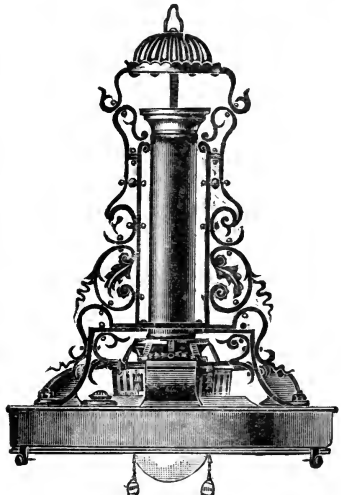

FIG. 299.—SUNLIGHT LAMP.

dipping into an annular reservoir fitted with a reflector as shown. Sometimes the wicks themselves constitute the burner. They are then so arranged that their ends form a circle. The air supplied to the burner is heated by passing over the surface of a porcelain cylinder, and is directed on to the flame by a cone.

Although in England and America flat-wick burners have been far more

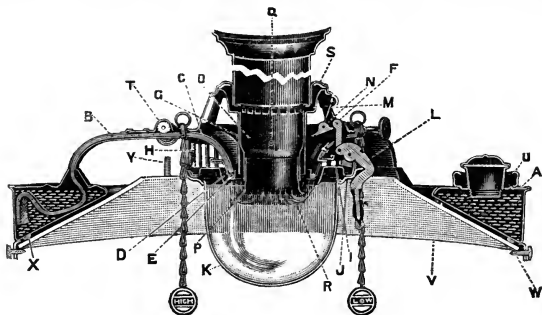

FIG. 300.—SUNLIGHT LAMP.

#### DESCRIPTION.

- |   |   |
|---|---|
| <p>A. Section of annular reservoir.<br/>         B. Section of wick-tube showing feeding-wick.<br/>         C. Wick-cones connecting feeding-wicks to burning-ring wick.<br/>         D. Burner-cap carrying ring-wick, bayonetted on to pins attached to wick-cones.<br/>         E. Ring- or burning-wick section in its place in burner-cap.<br/>         F. Connecting-rods.<br/>         G. Extension of chimney projecting downwards from and secured to conical ring, perforated below for entrance to interior of flame of air which is heated in its passage by coming in contact with the outside of chimney.<br/>         H. Perforated box through which the air passes to the outside of flame.<br/>         I. Air-cone which directs the outside air on to the proper part of flame.<br/>         J. Bezel jointed on to box, H, which carries the glass bowl.<br/>         K. Glass bowl.<br/>         L. Lever catch and handle.</p> | <p>M. Perforated conical ring fixed on top of wick-cones, and carrying the chimney, etc.<br/>         N. Horse-shoe lever.<br/>         O. Chimney cone-holder.<br/>         P. Chimney cone.<br/>         Q. Holes in chimney cone-holder on which it is balanced on pins from horse-shoe lever, N.<br/>         R. Flame.<br/>         S. Regulator ring carried between M and G, having openings similar to and capable of being brought in line with openings in M. This ring is adjusted by pulling the labels "high" and "low."<br/>         T. Winder for feeding-wick.<br/>         U. Oil-filler and cork.<br/>         V. Reflector.<br/>         W. Screws in tabs secured to reservoir on which reflector rests.<br/>         X. Rubber pads to keep reflector from shaking.<br/>         Y. Screws to secure the frame of the lamp to the reservoir.</p> |
|---|---|

largely used than the Argand form until within comparatively recent years, flat wicks are rarely employed on the European continent.

In Germany the most commonly used burner is the "Cosmos," which is of the Argand type. It has neither the inner air-tube passing through the reservoir nor the "Liverpool" button, and accordingly it is necessary to use with it a chimney which is much constricted near the base. The Argand burners introduced by C. H. Stobwasser & Co., Wild & Wessel, and Schuster

& Baer, under the names "Victoria," "Phoenix," "Moon," and "Helios," are provided with disc air-deflectors. In the lamps manufactured by Kumberg for burning heavy Russian oil, especial attention has been given to the supply of air and to the conservation of heat at the point of combustion of the oil.

Makaroff's lamp for heavy oils has an annular reservoir connected by two tubes with a lower chamber, which extends upwards as a central cylinder, to the burner. Air is admitted to the latter through the space between the cylinder and an outer metal jacket, heat derived by conduction from the burner-fittings being thus communicated to the air-current, and the oil being at the same time warmed. An ordinary flat-wick burner is used, and the reservoir is enclosed in a conical metal vessel. It is stated that, owing to the protection from air-draughts afforded by its shape, the lamp burns with a very steady flame, and is only slightly affected even by rapid movement. An improvement has been effected in this lamp by the addition of two fixed auxiliary wicks, one on either side of the principal wick. These are of unequal height, one of them only reaching as high as the burner, while the other extends to within a small distance from the flame, and is protected from contact with it by a metal cap.<sup>1</sup>

A mineral-oil lamp has been patented by Schülke, in which ordinary kerosene is burned in the form of vapour. The oil passes from the reservoir at the top of the lamp through a coil of brass tubing of small diameter, and is delivered into the vaporising-chamber. Thence the vapour escapes downwards through a number of burner-tubes arranged concentrically so that an inverted Argand flame is produced. The vaporisation is commenced by burning a small quantity of methylated spirit in a cup beneath the burner, and is continued by the heat emitted in the combustion of the oil. The lamp is of the "suspension" type, and is intended for the lighting of large spaces.

Lamps in which a non-luminous flame is produced by burning kerosene vaporised by passage through a heated tube are also employed for heating purposes. The well-known "Primus" stoves on this principle are described later (p. 911).

The principle of the incandescent gas-burner has been applied by E. Spiel, of Berlin, and others, in the construction of mineral-oil lamps in which a Welsbach mantle is heated by a non-luminous flame, produced by the combustion of the vapour of ordinary kerosene. Experiments made in the author's laboratory indicate that more than double the amount of light usually yielded by a given quantity of mineral oil may thus be obtained. The Kitson lamp is described on p. 900.

**Illuminating Power and Oil Consumption.**—The actual lighting efficiency of a mineral-oil lamp depends, of course, principally upon the quantity of oil burned in a given time, or, in other words, upon the size of the burner, but Argand burners almost invariably give more light in proportion to the oil burned than duplex or single flat-wick burners. An extended series of experiments made in 1879 by the author and his brother, Mr. T. Horne Redwood, indicated that with the principal lamps then in use, the oil-consumption was from 45 to 65 grains per candle-light per hour, whilst, in a more recent series of tests, carried out with the assistance of Mr. Robert Redwood, with the ordinary forms of tubular and flat-wick burners, the consumption was found to range from 41 to over 70 grains.

The considerable diminution in the light afforded, which is sometimes experienced in the use of mineral-oil lamps, may be due to the imperfect con-

<sup>1</sup> *Dingler's polytechn. Journ.*, cclxxv, 568 (1890).

struction, or defective or dirty condition of the burner; to the use of a reservoir of insufficient diameter, resulting in a depression of the oil-level which soon overtaxes the capillary power of the wick; to the employment of an inferior wick; or to the unsatisfactory quality of the oil. The accidental accumulation of a little water in the oil-reservoir frequently seriously interferes with the combustion.

The relative illuminating powers of various descriptions of mineral oil are largely dependent upon the conditions under which the oils are burned. The lamps commonly in use were designed for burning American kerosene and Scottish paraffin-oil, and do not usually give equally good results with Russian kerosene. Burners and chimneys have been made in Germany with special reference to the requirements of Russian oil, but have not been generally adopted.

A series of comparative tests with American and Russian oils in the various lamps were made by Professor Vivian B. Lewes with the results shown in Table CLI.

TABLE CLI.—COMPARISON OF LAMPS AND OILS.

Type and Name	Grains of Oil per Candle-power per Hour.		Total Candle-power.	
	American.	Russian.	American.	Russian.
Circular wick—				
Veritas (60 line), . . .	64·5	112·5	112·5	78
„ (30 line), . . .	42·5	50	60	60
„ (20 line), . . .	43·75	58·5	40	35
Ariel (12 line), centre draught, .	52·8	70·9	18	18
Reading (14 line), . . .	97·9	85·4	12	12
Cosmos (10 line), . . .	63·9	97·2	9	9
Wizard (15 line), . . .	56·9	51·3	18	19
Flat wick, single—				
Wanzer (no chimney), . . .	42·6	48·3	17	15
Solid slip gauze and cone, . . .	84·4	84·4	8	8
Old slip, fixed gauze, . . .	60·9	89·3	7	7
Flat wick, duplex—				
Feeder wick, . . .	56·2	55·7	20	22
Ordinary, . . .	51·2	46·6	20	22

American oil—Specific gravity, 0·7904; flashing-point, 110° F.

Russian oil—Specific gravity, 0·823; flashing-point, 83° F.

The character of the wick, the dimensions of the chimney, and the size and shape of the oil-reservoir, are factors of only slightly less importance than the form of the burner. The temperature at which the oil is supplied to the wick also affects the result. Even when every effort is made to establish uniform conditions for testing purposes, a number of burners of similar description will often be found to exhibit differences with the same oil.

Very little attention has been given to the amount of heat emitted by illuminants, whereas it is in reality a matter of great importance in a small or ill-ventilated room. Taking a lamp-oil as giving 18,200 B.Th.U. per lb., 50 grains, yielding one candle of illumination, would give 130 B.Th.U.; so that 100 candle-power from the best forms of lamp as regards light emission would yield 13,000 B.Th.U. per hour, whilst the same amount of light obtained from

gas, used in an inverted incandescence burner with a consumption of 5 cubic feet per hour, would give only 2600 B.Th.U. with London gas, with a heat value of about 520 B.Th.U. per cubic foot.

Compared with the older forms of gas-burner, however, oil was the cooler illuminant, as is shown by the following table, in which the heat evolved per candle for various forms of burner is given :—

B.Th.U. DEVELOPED PER CANDLE PER HOUR.		B.Th.U.
Oil lamp,	. . . . .	130
Gas—Flat flame (No. 4 union jet),	. . . . .	286
Argand,	. . . . .	171
Regenerative,	. . . . .	85
Incandescent mantle,	. . . . .	26

The apparent greater heat of an oil-lamp as compared with gas burnt in a flat-flame or Argand burner is due to the gas-burner being above the level of the head, and the oil-lamp upon the table.

No burner has been selected by common consent for use in making comparative tests of mineral oils, nor have any other testing conditions been agreed upon. Comparisons of the various mineral oils of commerce have been made from time to time, and some of the results obtained have been published, but from what has been already stated, it will be evident that such results must be of very limited value, and may even be misleading, for it is extremely difficult, if not impossible, to reproduce the average conditions under which mineral oils are used by the various classes of the community.

It will be obvious that similar difficulties stand in the way of instituting any precise comparison between the respective costs of mineral oils and of other illuminating agents ; nevertheless, general conclusions may be arrived at.

According to the experience of the author and his brother, the average consumption of oil per candle-light per hour, in the case of duplex burners with an illuminating power of about 28 standard candles, is about 50 grains, and in the experiments quoted in the previous page this view is confirmed. On the basis of a consumption of 50 grains, a gallon of oil, of 0.800 specific gravity, would give 1120 candle-hours, and assuming that the lamp was giving the light of 28 candles, would last for 40 hours.

During recent years great changes have taken place in the quality of the gas supply to all large towns. The general adoption of the incandescent mantle has rendered the high candle-power gas that used to be supplied for consumption in flat-flame burners not only unnecessary, but even less fitted for use with the mantle than a gas containing smaller quantities of heavy hydrocarbons, and therefore of lower illuminating and heat values, but more easily supplied with the necessary amount of air in the burner.

The general standard now adopted is that of calorific value in place of candle-power. A gas of about 520 B.Th.U. per cubic foot will give at ordinary pressure from 14 to 20 candles per cubic foot with the mantle, according to the condition of mantle and burner, whilst with inverted burners the duty is slightly higher, and if high-pressure gas is employed may be as high as 40 candles per cubic foot.

In an ordinary dwelling-house a few flat-flame burners will still be found where the conditions render the employment of mantles unnecessary or inadvisable, whilst some of the mantles in use will have had their lighting power diminished by age or injury, and many of the burners will have had their efficiency lowered by dust and corrosion. It may therefore be taken that the light from the gas burned under these conditions averages 12 candles

per cubic foot of gas consumed, and that the 1120 candle-hours would be obtained by a consumption of 93.3 cubic feet.

The introduction of the incandescent mantle has had an effect on the gas industry of the world that cannot be overrated, and it was natural, therefore, that its application to the flame produced by the vaporisation of oil should be attempted. It is clear that, inasmuch as oil-gas and oil-vapour differ from coal-gas only in the larger proportion and greater complexity of the hydrocarbon molecules present, it needs only a sufficiently large proportion of air to be mingled with the oil-gas or vapour before combustion to make the flame available for the same method of developing light.

The difficulties which exist in attaining this end are, however, very great, as the very richness of the hydrocarbons renders it a matter of considerable difficulty to get the necessary amount of air thoroughly mixed with the gas.

A non-luminous flame can be obtained by burning a mixture of 1 volume of coal-gas with 2.27 volumes of air; but if the flame be superheated, a certain proportion of luminosity will reappear, as the increased temperature causes the decomposition into carbon and hydrogen of the hydrocarbon molecules in the gas, which could not take place when the gas was cool, owing to their separation and dilution with air. If a mantle be placed on such a flame, the superheating caused by the mantle itself will soon tend to the decomposition of the hydrocarbons in the gas, with the result that the mantle is blackened and rapidly destroyed. An increased proportion of air, however, entirely alters the flame, and the hydrocarbon molecules being burnt up before impact with the heated surface of the mantle, all chance of blackening is avoided.

With the flame yielded by gasified or vaporised oil this trouble proved to be a serious one, as although it was an easy matter to obtain a non-luminous flame, yet blackening made its appearance directly the mantle was placed over it, whilst with a further supply of air the flame required constant attention, a factor which was quite sufficient to prevent its adoption in daily practice.

Another source of trouble was found in the wick, the slightest irregularity of which seriously interfered with the correct working of the lamp, and it is by no means an easy matter to obtain a wick that is perfectly uniform, so the duty of the wick was limited to drawing the oil up into a vaporising chamber where the oil-gas was produced, which, on then being mixed with air, gave the flame.

In the earlier types of incandescent oil-lamps, a circular wick was generally used to bring the oil to within a short distance below the burner head, and at this point the oil was vaporised by the heat conducted from the flame by the metal of the burner. A central tube furnished one air-supply, whilst a second was so arranged as to discharge itself almost horizontally on to the burning gas at the base of the flame, resulting in a non-luminous and very hot flame. The necessity for careful and constant attention, however, and the irregularity of their performance, prevented these lamps from attaining commercial success.

An ingenious lamp was devised, in which oil and water were vaporised by the heat of a little oil-lamp in a lower and separate chamber, and the mixture of oil-gas and steam was then burnt in a burner-head with a special arrangement of air-supply, heating a mantle suspended above the burner-head.

A very efficient incandescent-mantle oil-lamp has been made by Mr. Arthur Kitson, on the principle of injecting oil under pressure from a fine tube into a chamber where it is heated by the waste heat escaping from the flame below. The vapour thus produced is made to issue from a small jet under the pressure caused by the initial air-pressure and the expansion in the gasifying tube.



This jet of gas is then led into what is practically an atmospheric burner, and it draws in with it sufficient air to ensure its combustion with a non-luminous blue flame of great heating power, which is utilised for rendering incandescent a large mantle.

In this lamp, as used for street lighting, the oil-reservoir is in the base of the pillar; it is made of steel, and tested to a high pressure in order to ensure its being absolutely safe at the pressure at which it is used. A small pump enables the oil to be put under a pressure of air amounting to 50 to 60 lbs., by which it is forced up through a small capillary tube to the burner-head. Here it passes through a small cross-tube containing filtering material for removing any solid particles in it, and it is then ejected through a small aperture into a lower cross-tube placed immediately above the top of the mantle, the heat from which, passing upwards, causes vaporisation and partial gasification of the oil. The mixed gas and vapour rush out under considerable pressure from a small aperture in the side of the far end of the tube down what is practically an inverted Bunsen tube, through the holes in the side of which it draws in sufficient air to render the flame at the burner-head not only non-luminous but sufficiently oxidising in its character to prevent any deposition of carbon on the mantle. By the time the burner-head is reached, the pressure of the gas is almost reduced to that of the atmosphere again, so that the wear of the mantle is not excessive.

The chief difficulties found with the early forms of this lamp were the occasional clogging of the small vapour-hole with carbon, and the risk that the oil might be turned on accidentally when the lamp was not in use. Another difficulty was that a defective valve might cause a slight leakage of oil through the vapour-tube into the burner, which might, in certain circumstances, have resulted in the auxiliary flame turned on to heat the vapour-tube causing a slight flare.

These objections have been surmounted, the vapour-tube being made with a needle-holder and needle running longitudinally through it, so that the small vapour-hole can be cleared in case of any stoppage by simply pulling a small chain attached to a lever-arm working the needle, whilst any chance of oil escaping, either from a leaky valve, or from turning on the oil-supply to the cold lamp, is prevented by a thermostatic valve, which prevents any access of oil to the vapour-tube until the latter is at a sufficient temperature to vaporise the oil properly. This valve operates by the difference in expansion of the two metals employed in its construction, and being above the vapour-tube, it cannot get hot enough to release the oil until the vapour-tube has been heated to the proper temperature.

Experiments made with this lamp show that, with a large single burner, it is perfectly easy to obtain illuminating values of from 1000 to over 1200 candles.

**Lamp Globes.**—In the diffusion globes of Blondel and Psaroudaki, the principle of the Fresnel lighthouse-lenses is applied. These globes are made of transparent glass, finely grooved on scientific principles, and their effect is to diffuse the light with very little loss by absorption. The increase in illuminating power, in the field below a horizontal line passing through the flame, is stated to be 12 per cent., and the loss by absorption from 9 per cent. to 13 per cent. This loss is only about the same as occurs in the use of plain transparent glass, while ground glass or opal globes absorb from 35 per cent. to 70 per cent.

**Extinguishers.**—It has been already pointed out that some form of extinguisher is usually fitted to mineral-oil lamps, and that of Hinks has been described. The earliest form appears to have been that with which the

“Brighton” burner, patented in 1862, was provided. In this burner, the air-deflector or “Liverpool” button rested upon a pin, the withdrawal of which allowed the button to fall upon the wick and extinguish the flame.

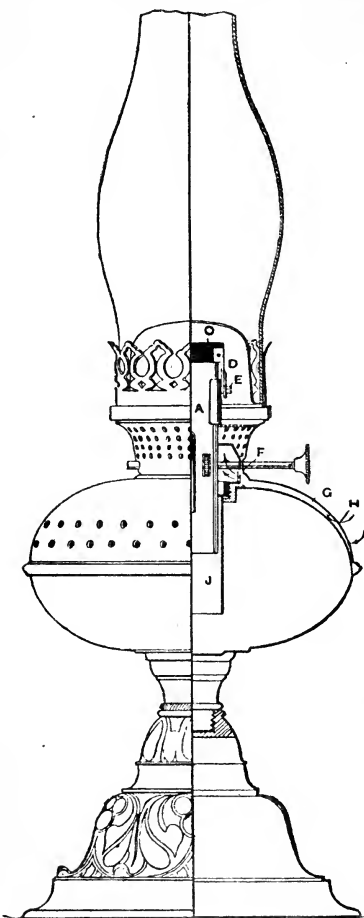

FIG. 301.—VICTORIA LAMP.

In Sherring's "Victoria" lamp (figs. 301, 302) the burner is furnished with two caps, C D, pivoted at E, which automatically close over the wick-tube, A, and wick, B, when the lamp is overturned. The upper part of the brass oil-container is jacketed, an air-chamber, G (fig. 301), being thus formed. A portion of the air-supply enters at H, and in passing through the chamber is warmed, while the upper part of the container is at the same time cooled. The burner screws tightly at F into a cylinder or tube, J, which serves to prevent the outflow of the greater part of the oil in the event of the lamp being overturned. Postlethwaite's automatic extinguisher (fig. 303) consists of two spring shutters which meet over the wick. The burner-dome is made in two parts, the upper being

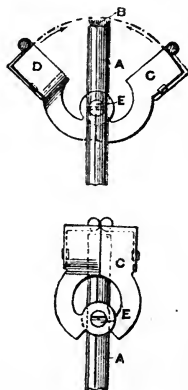

FIG. 302.—VICTORIA LAMP (EXTINGUISHER).

sufficiently weighty to hold the shutters open. When this portion is displaced by the overturning of the lamp, the shutters are allowed to close. A lever for closing them at will is also provided.

In Devoll's "Water safety-lamp" the oil-reservoir is surrounded by a

water-jacket, from which the water runs into a cap encircling the air-holes of the burner, when the lamp is overturned, the flame being thus extinguished.

**Oil-Supply.**—To provide a large supply of oil for a lamp, Hampton & Sons introduced the "Perpetual" lamp, the base of which contained, in a large reservoir, a week's or a month's supply. The lamp proper was supplied, when necessary, from this reservoir, by a concealed force-pump. Joseph Hinks & Son introduced a somewhat similar arrangement, the base of a pedestal-lamp forming the storage-reservoir, from which the oil was raised to a small oil-chamber beneath the burner by the intermittent action of a piece of mechanism driven by a spring.

**Safety Appliances.**—To prevent the communication of flame to an inflammable or explosive mixture in the oil-reservoir, Hinks & Son have, at the suggestion of the author, enclosed the wick beneath the burner in a wire-gauze cylinder or cage, as shown in fig. 288. The prolonged wick-tube fitted to the lamps of Defries and others is intended to serve the same purpose.

**Wicks.**—The value of a wick depends upon the capillary attraction which

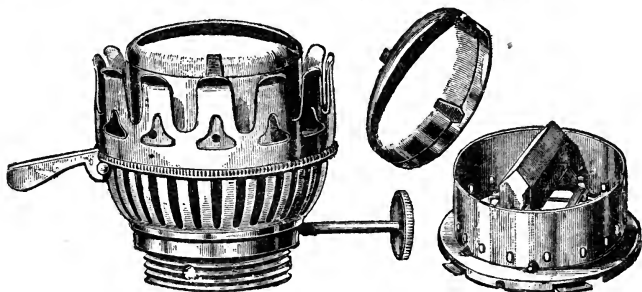

FIG. 303.—POSTLETHWAITE EXTINGUISHER.

it is capable of exerting, and this varies with the quality of the cotton used and the manner in which the wick is made. A loosely-woven wick of "long-staple" cotton gives far better results than a tightly-woven wick of "short-staple" cotton, and a series of experiments on flat wicks of the same width in ordinary use, performed in the laboratory of the author, showed that there was a variation in the proportion of 1 to 2.5 in the quantity of oil raised under similar conditions. By subjecting wicks to a process of washing their capillary power is greatly increased. Wicks are found to absorb from 4 to 6 per cent. of their weight of moisture from the atmosphere, and as the capillary power is thus seriously impaired, it is advisable to carefully dry them before use. The choking of the wick which sometimes occurs appears to be due to the absorption of water, at least in many cases, for Nakamura<sup>1</sup> finds that the wick recovers its power when dried. Hence also the necessity for avoiding the collection of a small quantity of water in the oil-reservoir.

**Incombustible Wicks.**—The wicks of the lamps employed by the Vestal Virgins are said to have been made of asbestos, and in the *Philosophical Transactions*, 1684, xiv, 806, Dr. Plot proposed the use of wicks of asbestos, or of gold, or other metal wire, "which will lick up oyl as well as any other wick." A. and D. Gordon (Patent No. 4638, 1822) patented the use of wicks of platinum, gold, silver, or copper drawn into threads, or of glass drawn into capillary tubes

<sup>1</sup> *Journ. Soc. Chem. Ind.*, ii, 535 (1883).

and bound into a bundle, and Roberts (Patent No. 10,842, 1845) employed cane, porous wood, or asbestos.

In 1887 Bondini and Tubini patented in this country (No. 10,502) the use of an ordinary cotton wick protected at the end or tip by enveloping it in a capsule or sheath of wire gauze or perforated sheet-metal. A wick patented by Heinrichs consisted of an asbestos tip forming the burner, an intermediate portion of mineral substance, and a lower portion of felt. The "Phoenix Perpetual" lamp wick was prepared by treating the upper end of a cotton wick for a length of about an inch with an incombustible material. In the Benson-Lee lamp there was a carbon burner supplied with oil by a cotton feeder-wick. The burner was of the Argand type, and the carbon ring was mounted immovably in a brass cell. The lamp was so constructed that, on being overturned, outflow of oil could not occur. The adjustment of the flame was effected by controlling the air-supply, and the lamp was extinguished by cutting off the air-supply.

Wicks of the ordinary description are usually adjusted by toothed wheels fixed on a spindle which is turned by a milled head. In some cases the wick is carried by a tube or frame, which is raised and lowered either by a rack and pinion, or by a worm cut on the burner tube (the movement being effected by revolving the burner), or by a sliding rod or flexible wire.

**Lamp Accidents.**—The subject of lamp accidents, to which much attention has been directed, was experimentally investigated as long ago as 1871, by Dr. Chandler of New York. The experiments, however, bore more particularly on the occurrence of explosions produced by the ignition of a mixture of petroleum vapour and air in the lamp-reservoir, and, as pointed out by Peckham, Abel, and others, a large proportion of lamp accidents are due simply to the overturning or dropping of the lamp.

The following extract from a report by Sir Frederick Abel and the author to Her Majesty's Chief Inspector of Explosives (1890), embodies the principal results of an investigation of the subject of accidents with mineral-oil lamps, which was conducted by Sir F. Abel, with the assistance of Dr. Kellner and the author:—

"(a) A large proportion of the accidents occurring in the use of mineral-oil lamps are not due to the occurrence of explosions in the lamps. Many recorded instances of the breaking-out of a fire, or the destruction of or injury to life, which are ascribed to lamp-explosions, have evidently been caused by upsetting or dropping a burning petroleum-lamp. The sudden cooling of a glass reservoir which has become much heated by the burning of the lamp may also result in fracture. The substitution of benzoline (mineral spirit) for mineral oil has in some cases probably caused the accident.

"(b) There are, however, numerous cases of accidents which have undoubtedly been due to the occurrence of explosions in lamps, and our experiments have enabled us to arrive at the following conclusions with respect to the causes of such explosions:—

"If the lamp be so carried or rapidly moved as to agitate the oil, a mixture of vapour and air may make its escape from the lamp in close proximity to the flame, and, by becoming ignited, determine the explosion of the mixture existing in the reservoir. This escape may occur through the wick-tube itself if the wick does not fit the holder properly, or through openings of sufficient size to allow flame to pass them readily, which exist near the wick-tube in many burners. Some lamps have a tube inserted in the burner, through which the reservoir can be supplied with oil, and if this tube be not effectively closed it may constitute a channel for the passage of flame to the vapour- and air-

mixture in the reservoir. The existence of an imperfectly closed filling-aperture in the body or reservoir of the lamp also favours the occurrence of an explosion. A sudden cooling of the lamp, resulting from its exposure to a draught, may give rise to an inrush of air, thereby increasing the explosive character of the mixture of vapour with a little air already contained in the reservoir, and the flame of the lamp may at the same time be drawn or forced into the air-space filled with that mixture, especially if the flame has been much reduced in size by lowering the wick, as the point of combustion is thereby brought nearer to the reservoir.

“If the practice is resorted to of blowing down the chimney with a view to extinguishing the lamp, the effects already indicated as producible by exposure to a draught may be brought about. If the wick be lowered very much, or if for some other reason the flame becomes much reduced in size, so that it is burning beneath the dome, the lamp may become much heated, and its susceptibility to the effects described will be increased. Heating of the lamp-reservoir is likely to be promoted if the air-passages in the burner are obstructed by dirt or charred wick. If the wick is not long enough to reach the bottom of the oil-reservoir, and the lamp is allowed to burn until the surface of the oil is scarcely level with the end of the wick, a proper supply being therefore no longer furnished to the flame, the wick may char down to and below the level of the toothed wheels in the wick-tube, and drop into the reservoir, while the upper end is still burning, and may thus cause an explosion. The accidental dropping of the still burning wick into the oil-reservoir, through the wick being turned down below the level of the toothed wheels in the act of extinguishing the lamp, is also a fruitful source of explosions. If the flashing-point of the oil used be below the minimum (73° Abel test) fixed by law, and even if it be at that point, or a little above it, vapour will be given off comparatively freely, but the mixture of petroleum-vapour and air formed in the upper part of the reservoir of the lamp will probably be feebly explosive in consequence of the presence of an excess of the vapour. On the other hand, if the flashing-point of the oil be comparatively high, the vapour will be less readily or copiously produced, and the mixture of vapour and air may be more violently explosive, because the proportion of the former to the latter is likely to be lower, and nearer that demanded for the production of a powerfully explosive mixture. If the quantity of oil in the lamp-reservoir be but small, and the air-space consequently large, the ignition of an explosive mixture produced within the lamp will obviously exert more violent effects than if there be only space for a small quantity of vapour and air, because of the lamp being comparatively full.

“Experiments have demonstrated that the burning of an oil of comparatively high flashing-point is more likely to cause heating of the lamp than the use of an oil of comparatively low flashing-point, in consequence of the higher temperature developed by the former, and of the greater difficulty with which some oils of that description are conveyed to the flame by the wick. It therefore follows that safety in the use of mineral-oil lamps is not to be secured simply by the employment of oils of comparatively high flashing-point (or low volatility), and that the use of such oils may even in certain cases give rise to dangers which are small, if not entirely absent, with oils of comparatively low flashing-point.

“The character of the wick materially affects not only the illuminating power of the lamp but also its safety. A loosely-plaited wick of long-staple cotton draws up the oil freely and regularly, even when the supply of the liquid in the reservoir becomes almost exhausted, and little charring of the wick

takes place if the oil is of good quality. But if the wick be tightly plaited, or if it be made of short-staple cotton of inferior capillary power, the oil will be less copiously supplied to the flame, and considerable charring of the wick, with largely increased heating of the burner, will ensue. The use of a wick which has not been thoroughly dried before immersion in the oil, or the capillary power of which has become impaired by prolonged use, may bring about the same result.

“Our experiments have also led us to the conclusion that a lamp-explosion is not usually sufficiently violent to cause the fracture of an ordinary glass reservoir, although in several recorded cases it has had this effect; but although it may not, the alarm created by the explosion may lead to the lamp being dropped if it is being carried at the time, and if the reservoir is of glass, fracture will probably ensue and the liberated oil may become ignited.”

The following suggestions as to the construction and management of mineral-oil lamps, founded on recommendations made by Sir Frederick Abel and the author, were formulated and published by the Metropolitan Board of Works in 1885:—

1. That portion of the wick which is in the oil-reservoir should be enclosed in a tube of thin sheet metal, open at the bottom, or in a cylinder of fine wire gauze, such as is used in miners' safety-lamps (28 meshes to 1 inch).
2. The oil-reservoir should be of metal, rather than of china or glass.
3. The oil-reservoir should have no feeding-place or opening, other than the opening into which the upper part of the lamp is screwed.
4. Every lamp should have a proper extinguishing apparatus.
5. Every lamp should have a broad and heavy base.
6. Wicks should be soft, and not tightly plaited.
7. Wicks should be dried at the fire before being put into lamps.
8. Wicks should be only just long enough to reach the bottom of the oil-reservoir.
9. Wicks should be so wide that they quite fill the wick-holder without having to be squeezed into it.
10. Wicks should be soaked with oil before being lit.
11. The reservoir should be quite filled with oil every time before using the lamp.
12. The lamp should be kept thoroughly clean, all oil should be carefully wiped off, and all charred wick and dirt removed before lighting.
13. When the lamp is lit, the wick should be at first turned down, and then slowly raised.
14. Lamps which have no extinguishing apparatus should be put out as follows:—The wick should be turned down until there is only a small flickering flame, and a sharp puff of breath should then be sent *across* the top of the chimney, *but not down it*.
15. Cans or bottles used for oil should be free from water and dirt, and should be kept thoroughly closed.

Dr. Fock, in a lecture delivered in 1888 before the Prussian Industrial Society, on experiments made by the German Standards Commission, stated that the pressure resulting from the explosion of a mixture of petroleum-vapour and air in a *closed* vessel may be as high as 14 atmospheres (210 lbs. per square inch), the most violent explosions apparently occurring at about 8° C. (14.4° F.) above the flashing-point of the oil. He recommended the use of metallic or other unbreakable reservoirs, but considered that the risk of

fracture of the reservoir was small, as the pressure was relieved through the wick-tube. Even a cracked reservoir was found to withstand the pressure.

**Ships' Lights.**—The lamps employed for ships' lights and for the lighting of railway carriages must be of special construction in order to prevent the extinction of the flame by wind or water. In one form the draught is produced by a tapering metal chimney, and the flame is supplied with air which enters a chamber between two plates at the back of the lantern, through two vertical tubes about one-third the height of the chamber and half an inch or more in diameter. Wire gauze is fitted to the lower end of the tubes to further break up the air-current. The products of combustion pass up the chimney and impinge on an inverted cone, round which, and under a covering plate, they escape. The air-supply is thus practically independent of the force of the wind, and any extra air-current striking on the lantern rather assists in drawing away the products of combustion.

### SPRAY LAMPS.

For lighting large areas, especially in the open air, blast- or spray-burners have been introduced. Figs. 304 and 305 represent an improved form of the Lucigen lamp, originally patented by Lyle and Hannay (Patents, 1885, No. 7162; 1886, No. 1626; 1887, Nos. 1632 and 3113). A, is the oil-tank; B, the union for the compressed air, and the cock for regulating the supply; C, a moisture-trap for water separated from the oil; D, a blow-off cock; E, a flexible tube for the air connection; F, the burner-tube, carrying oil from the tank and having a nozzle, 13; G, the oil-valve; H, the air-valve; I, the air-tube leading to the coil heater; K, the combustion-chamber with internal coil for heating the air; L, the tube for leading the heated air to the burner; M, the burner; N, the oil-valve and tube for the pilot light, 17 (this device was found to be practically useless, and has been abandoned). In the use of this lamp, a supply of compressed air is connected at B, a steady pressure of about 15 lbs. per square inch in the pipes being required for efficient working. The oil is thus raised to the burner, and at the same time the air passes through the coil heater into the burner, where it heats and sprays the oil. The burner shown in the illustration has, in addition to an internal coil of several convolutions, an internal cast-iron baffle-plate, and an external wrought-iron casing. The latest form of the Lucigen lamp is provided with a far simpler combustion-chamber, consisting of a single casting without any internal fitting, and with one external coil of air-pipe. A Lucigen lamp of large size produces a solid tapering flame, about 3 feet in length and 9 inches in maximum diameter, with an illuminating power of 2000 to 2500 candles. Such a lamp consumes about 2 gallons of heavy mineral oil per hour.

The principle of the Lucigen lamp has been applied in the construction of burners for steam-raising, rivet-heating, etc. The rivets used in the building of the steamships *Campania* and *Lucania* were thus heated, and a similar system of heating was employed by Sir William Arrol in the construction of the Forth Bridge.

In the "Wells" lamp (figs. 306 and 307), patented by Wallwork and Wells (1882, No. 2352, and 1889, Nos. 6738 and 20,366), the oil is raised to the burner by compressed air. The reservoir is charged by means of a pump, P; and a screw-plug, V, vertically grooved so that air may be admitted by turning it, is fitted with a rod, V<sup>3</sup>, by which the height of the liquid may be ascertained. The usual form of the burner is shown in fig. 307, and consists of a hollow casting, *b*, in which are fitted a nozzle, *c*, and a cone, *d d*<sup>1</sup>. Hollow gills, *g*,

increase the heating-surface, and a cover, *f*, with air-holes, *f*<sup>3</sup>, is fitted round the casting. The oil becomes vaporised in the casting, and is burned in admixture with air which the outrush of vapour draws into the cone. The burner may be fitted with a wind-vane, *f*<sup>4</sup>, the tube, *a*, which carries the burner, being

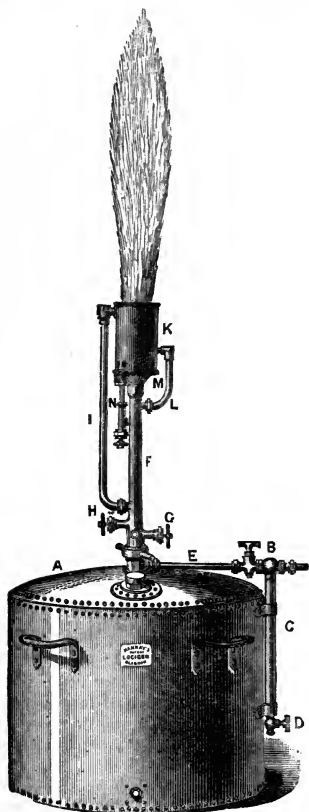

FIG. 304.

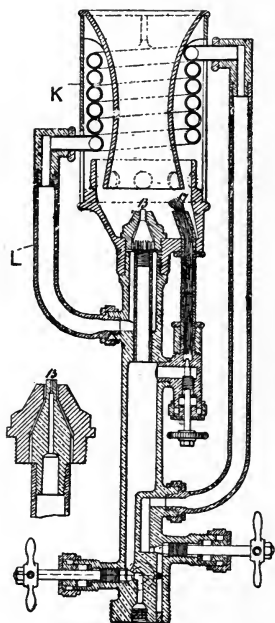

FIG. 305.

## LUCIGEN LAMP.

arranged to turn in the supply-tube, *L*<sup>6</sup>, so that the flame is kept in line with the wind.

The burner shown in fig. 306 consists of two hollow rings, *B*, through which the oil passes; the nozzle, *C*, through which the vapour of the oil escapes; and the cone, *D* *D*<sup>1</sup>, in which the oil-vapour mixes with air before burning. The lamp is started, in the case of both burners, by burning a piece of tow soaked in oil in a cup beneath the burner,



## MINERAL-SPIRIT LAMPS.

Lamps of various forms are in use for burning petroleum spirit or benzoline. The ordinary domestic "sponge lamp" or "benzoline lamp" is a small

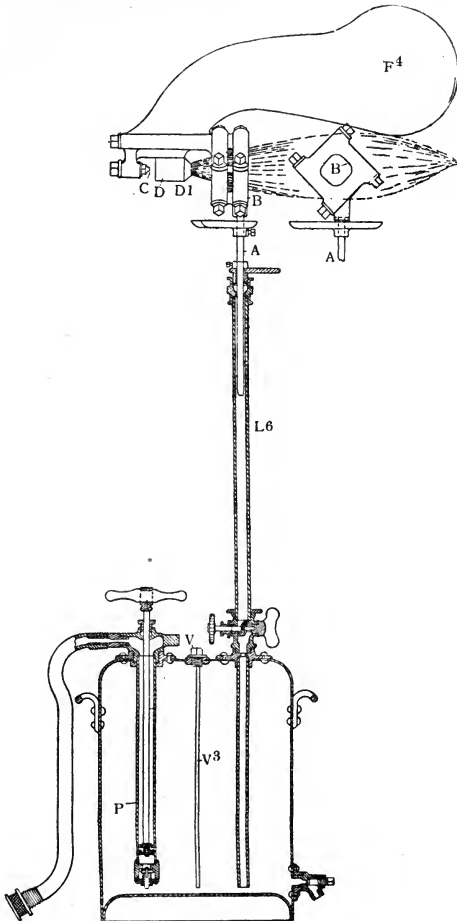

FIG. 306.—WELLS LAMP.

chimneyless lamp, with a metal reservoir filled with sponge, cotton, or other absorbent material into which the solid cylindrical wick passes. Only as much spirit as can be absorbed by the sponge is poured into the reservoir. In some of the lamps in which such spirit is used, the illuminating agent is vaporised

and burned at a jet with or without previous admixture with air. The simplest form of vapour lamp consists of a reservoir having at the top an opening communicating with the air, and at the bottom a tube extending downwards and terminating in an Argand burner. The reservoir contains an absorbent material which is saturated with gasoline, and from this the vapour, which is much heavier than air, flows downwards under sufficient pressure to give a steady flame at the burner. The costermonger's conical tin lamp, so largely used for producing an outdoor light, is one form of a lamp introduced by Read Holliday (Patents No. 12,015, 1848, and No. 12,965, 1850). The burner consists of a flat or annular chamber with perforations at the edge through which the illuminant passes. The reservoir is charged with benzoline or other mineral spirit, which flows down a tube to the burner, and burns there without

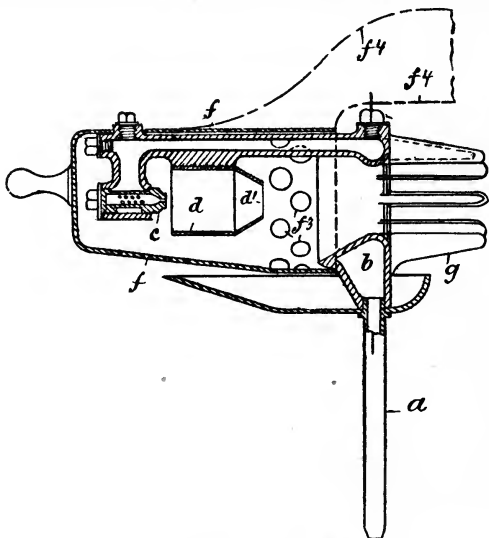

FIG. 307.—WELLS LAMP.

a wick. The supply is regulated by a tap, or by the introduction of cotton wool or other fibrous material into the supply-tube. The burner requires to be heated before use, as its action depends on the vaporisation of the escaping spirit.

### LAMPS FOR SOLID PARAFFIN.

A convenient form of miner's lamp for burning solid paraffin of low melting-point, was introduced by Young's Paraffin Light and Mineral Oil Company. The lamp had no chimney, and consisted of a little tin can with a projecting spout which formed the wick-tube. The flame was encircled by a copper ring which conducted heat to the paraffin, and maintained it in a fused condition round the wick. The Cera Light Company employed readily fusible paraffin in ships' signal-lamps. The burner with which these lamps were fitted had an air-deflecting cone, and the paraffin was kept fluid in the reservoir by a copper

wire formed into a helix above the flame and passing down by the side of the wick-tube into the reservoir, where it was bent into a coil.

**Concluding Remarks.**—In the limited space available in this work it has been impossible to describe more than a few of the appliances which have been introduced for the utilisation as a source of light of the various liquid products of petroleum, and for further information respecting mineral-oil and spirit lamps the reader is referred to articles by the author in the second volume of *Chemical Technology*, edited by Messrs. Charles E. Groves and William Thorp, published by Messrs. J. & A. Churchill, and to "The Petroleum Lamp," by Captain J. H. Thomson and Sir Boverton Redwood, published by Charles Griffin & Co., Ltd.

### HEATING STOVES.

As already mentioned in the introductory remarks to this section, most of the stoves supplied for the domestic use of petroleum products, in heating and

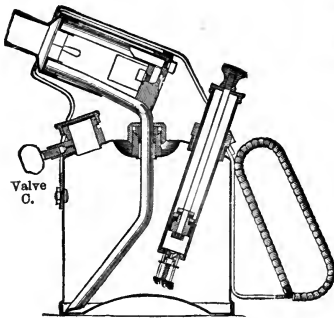

FIG. 308.—SECTION OF "AETNA" BLOW-LAMP.

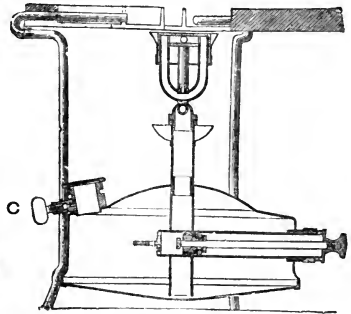

FIG. 309.—SECTION OF THE ROARER PRIMUS STOVE.

cooking, are practically lamps with wide wicks, and no special description of them is necessary; but heating stoves are now largely employed in which the principle of spraying, vaporising, and burning the vapour in an atmospheric burner is utilised to give a non-luminous flame of considerable heating power.

The "Primus" stoves are probably the best known of those working on this principle. They are largely used for domestic purposes, on yachts, and for camping. Industrial patterns include lamps such as the "blow-lamp" pattern used by painters and plumbers, whilst larger patterns are constructed for brazing and other purposes. The largest size has a tank capacity of 62 pints, and is stated to melt 2-inch copper rod in six minutes.

A section of one of the blow-lamps is shown in fig. 308, and of a domestic heating lamp in fig. 309.

Methylated spirit is poured into the cup surrounding the vaporising tube and ignited, so warming the tube. When sufficiently heated, pressure for forcing the paraffin through the vaporising tube is obtained by the small pump shown in the illustrations. Adjustment of the flame is attained by either increasing the pressure with the pump, or reducing it by opening the valve C. The lamps are also extinguished by completely opening this valve.

Blow-lamps of similar construction are frequently employed with benzoline, which is absorbed in loose cotton in the lamp body. No pump is required, the

pressure for starting the lamp being obtained by methylated spirit or benzoline poured in the cup at the top of the lamp body.

### AIR-GAS.

Air-gas consists of an inflammable mixture of air and the vapours of volatile liquid hydrocarbons, such as gasoline. The proportion of such vapours which air is capable of taking up, varies with the temperature and with the volatility

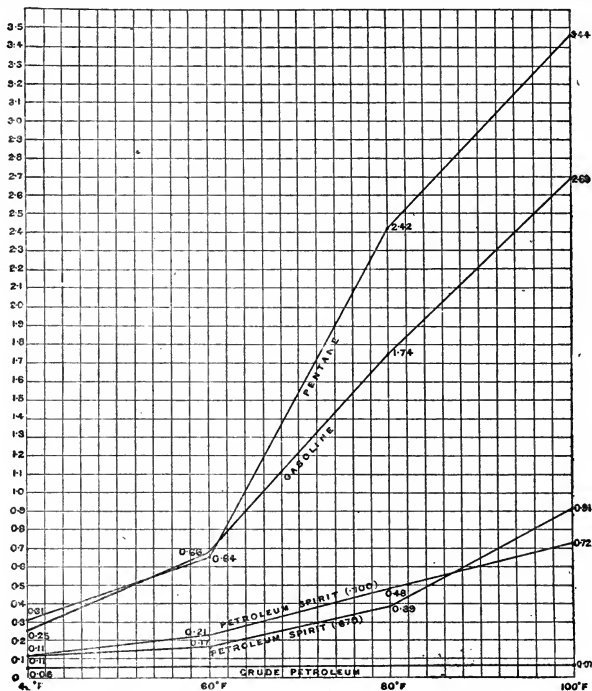

FIG. 310.—EVAPORATION OF HYDROCARBONS.

of the carburetted material used. One hundred volumes of air will retain of the vapour of gasoline of 0.65 specific gravity, 5.7 per cent. by volume at 14° F., 10.7 per cent. at 32°, 17.5 per cent. at 50°, and 27.0 per cent. at 68°. Air charged with 735 grains of gasoline vapour per cubic foot, has been found to possess an illuminating power of 16.5 candles when consumed at the rate of 3½ cubic feet per hour in a 15-hole Argand burner. Air-gas, besides being employed as an illuminating agent, has been used in gas-engines as a source of power.

The following is a description of experiments performed by the author, with the assistance of Mr. Blundstone,<sup>1</sup> with a view to the determination of the

<sup>1</sup> *Proc. Inst. Civ. Engineers*, cxvi, 199 et seq. (1894).

manner in which crude petroleum and certain volatile petroleum-distillates evaporate when subjected to a current of dry air. Though carried out in connection with an investigation relative to the formation of an inflammable or explosive atmosphere in tank-steamers, they bear on the question of the production of air-gas. In these experiments, dry air was caused to bubble slowly through the liquid in a series of graduated tubes maintained at a constant temperature. The volume of air which had travelled through the whole of the tubes, and the quantity of liquid which evaporated from each tube, were ascertained at intervals, a set of determinations being made at temperatures of 40°, 60°, 80°, and 100° F.

The results obtained are given in the following tables, and the volume of each liquid evaporated by 100 volumes of air (based upon the first set of readings at each temperature) is shown in fig. 310 :—

TABLE CLII.—PENTANE.

Temperature of Liquid.	Volume of Liquid.	Volume of Air passed through the Tubes.	Vols. of Air to 1 Volume of Liquid.	Volume of Liquid evaporated by 100 Volumes of Air.						
				Tube 1.	Tube 2.	Tube 3.	Tube 4.	Tube 5.	Tube 6.	Total.
° F.	c.c.	Litres.								
40	51·85	0·35	16·4	0·24	0·035	0·024	0·011	Nil.	Nil.	0·31
40	51·85	2·0	38·6	0·215	0·040	0·022	0·013	0·005	„	0·30
40	51·85	3·35	64·7	0·191	0·041	0·024	0·014	0·010	0·004	0·28
60	45·1	0·9	19·9	0·42	0·11	0·05	0·04	0·02	Nil.	0·64
60	45·1	3·8	84·2	0·20*	0·15	0·09	0·06	0·02	0·03	0·56
60	45·1	5·4	119·7	...	0·13*	0·10	0·07	0·04	0·03	0·37
80	41·7	0·7	16·7	0·91	0·50	0·30	0·26	0·26	0·19	2·42
80	41·7	1·8	43·1	0·41*	0·39	0·27	0·22	0·20	0·14	1·63
80	41·7	2·5	59·9	...	0·29*	0·26*	0·27*	0·26	0·20	1·28
100	31·1 (in 5 tubes)	0·9	28·9	0·75*	{ Not read }	0·78*	0·62*	0·71*	0·58	3·44

\* Tube empty before reading was taken.

TABLE CLIII.—GASOLINE (Specific gravity 0·639).

Temperature of Liquid.	Volume of Liquid.	Volume of Air passed through the Tubes.	Vols. of Air to 1 Volume of Liquid.	Volume of Liquid evaporated by 100 Volumes of Air.						
				Tube 1.	Tube 2.	Tube 3.	Tube 4.	Tube 5.	Tube 6.	Total.
° F.	c.c.	Litres.								
40	46·53	1·6	34·3	0·181	0·037	0·018	0·012	0·006	Nil.	0·25
40	46·53	2·75	59·1	0·163	0·049	0·029	0·016	0·012	0·007	0·27
40	46·53	4·0	85·9	0·142	0·05	0·03	0·017	0·016	0·01	0·26
60	44·7	0·9	20·1	0·40	0·12	0·06	0·05	0·03	Nil.	0·66
60	44·7	2·15	48·0	0·28	0·11	0·07	0·05	0·05	0·03	0·59
60	44·7	3·55	79·4	0·21	0·11	0·07	0·05	0·04	0·03	0·51
80	46·9	1·0	21·1	0·59	0·32	0·30	0·20	0·18	0·15	1·74
80	46·9	2·05	43·7	0·37	0·26	0·24	0·17	0·14	0·12	1·30
80	46·9	3·9	83·1	0·20*	0·20	0·17	0·14	0·12	0·10	2·93
100	36·0	1·15	31·9	0·49*	0·50*	0·53	0·39	0·46	0·32	2·69

\* Tube empty before reading was taken.

Note.—Rapid evaporation and distillation (with condensation of liquid in exit tube) occurred in experiment at 100° F.

TABLE CLIV.—PETROLEUM SPIRIT (Specific gravity 0.679).

Temperature of Liquid.	Volume of Liquid.	Volume of Air passed through the Tubes.	Vols. of Air to 1 Volume of Liquid.	Volume of Liquid evaporated by 100 Volumes of Air.						
				Tube 1.	Tube 2.	Tube 3.	Tube 4.	Tube 5.	Tube 6.	Total.
° F.	c.c.	Litres.								
40	47.7	0.9	18.8	0.09	0.01	0.01	Nil.	Nil.	Nil.	0.11
40	47.7	1.8	37.7	0.09	0.01	0.01	"	"	"	0.11
40	47.7	3.0	62.8	0.08	0.01	0.01	0.01	"	"	0.11
60	42.5	1.35	31.9	0.12	0.03	0.01	0.01	"	"	0.17
60	42.5	2.8	65.8	0.11	0.03	0.01	0.01	0.01	0.01	0.18
60	42.5	3.8	89.4	0.09	0.04	0.02	0.01	0.01	0.01	0.18
80	46.5	1.45	31.1	0.19	0.08	0.05	0.03	0.02	0.02	0.39
80	46.5	3.0	64.5	0.14	0.07	0.05	0.03	0.03	0.02	0.34
80	46.5	4.7	101.1	0.11	0.06	0.04	0.03	0.02	0.02	0.28
100	47.9	1.05	21.9	0.35	0.19	0.13	0.12	0.10	0.02	0.91
100	47.9	2.45	51.1	0.23	0.14	0.10	0.09	0.08	0.04	0.68
100	47.9	4.1	85.5	0.17	0.11	0.10	0.08	0.08	0.03	0.57

Note.—Slight distillation in experiment at 100° F.

TABLE CLV.—PETROLEUM SPIRIT (Specific gravity 0.700).

Temperature of Liquid.	Volume of Liquid.	Volume of Air passed through the Tubes.	Vols. of Air to 1 Volume of Liquid.	Volume of Liquid evaporated by 100 Volumes of Air.						
				Tube 1.	Tube 2.	Tube 3.	Tube 4.	Tube 5.	Tube 6.	Total.
° F.	c.c.	Litres.								
40	27.9	2.2	78.8	0.006	0.002	0.001	0.001	Empty.	Empty.	0.11
40	27.9	4.6	164.8	0.05	0.02	0.01	0.01	"	"	0.09
40	27.9	7.6	272.4	0.04	0.02	0.01	0.01	"	"	0.08
60	29.25	1.2	41.0	0.11	0.04	0.04	0.02	"	"	0.21
60	29.25	3.2	109.4	0.08	0.04	0.03	0.02	"	"	0.17
60	29.25	4.5	153.8	0.07	0.03	0.03	0.02	"	"	0.15
80	36.4	0.8	18.6	0.18	0.10	0.06	0.06	0.04	0.04	0.48
80	36.4	2.0	54.9	0.13	0.08	0.05	0.05	0.04	Empty.	0.36
80	36.4	3.6	98.8	0.10	0.06	0.05	0.04	0.03	"	0.28
100	44.5	1.2	26.9	0.22	0.13	0.12	0.11	0.07	0.07	0.72
100	44.5	4.2	94.3	0.12	0.08	0.07	0.06	0.05	0.04	0.42
100	44.5	7.3	164.0	0.09	0.06	0.05	0.05	0.04	0.03	0.32

Note.—Slight distillation in experiment at 80° F. Considerable distillation in experiment at 100° F.

TABLE CLVI.—CRUDE PETROLEUM (Specific gravity 0.801).

Temperature of Liquid.	Volume of Liquid.	Volume of Air passed through the Tubes.	Vols. of Air to 1 Volume of Liquid.	Volume of Liquid evaporated by 100 Volumes of Air.						
				Tube 1.	Tube 2.	Tube 3.	Tube 4.	Tube 5.	Tube 6.	Total.
° F.	c.c.	Litres.								
40	30.0	1.4	46.6	0.019	0.019	0.012	0.012	Empty.	Empty.	0.06
40	30.0	2.7	90.0	0.016	0.016	0.013	0.011	"	"	0.055
40	30.0	4.0	133.3	0.113	0.111	0.009	0.009	"	"	0.042
100	32.1	1.9	59.1	0.037	0.018	0.009	0.009	"	"	0.07
100	32.1	3.7	115.2	0.027	0.014	0.009	0.009	"	"	0.06
100	32.1	5.6	174.4	0.020	0.018	0.011	0.008	"	"	0.05

Taking the first set of readings in the case of pentane, it is seen that the volume of liquid evaporated by 100 volumes of air was 0.31 at 40°, 0.64 at 60°, 2.42 at 80°, and 3.44 at 100° F., a progressive increase which indicates the effect of augmented temperature. The amount of evaporation from the individual tubes at 40° F. was (1) 0.24, (2) 0.035, (3) 0.024, (4) 0.011, (5) nil, (6) nil, so that the air was saturated in its passage through the first four tubes. On the other hand, if the totals of the three determinations at 40°, or at 60°, or at 80° are compared, it will be seen that as the volume of air in relation to a given volume of liquid is increased, the percentage of liquid taken up by the air diminishes in consequence of the air passing away not fully saturated. The amount of volatilisation, of course, also diminishes as the height of the liquid column decreases. The results show that although complete saturation of the air is a slow process, a very considerable amount of vapour is readily taken up.

### THE CARBURETTING OF COAL-GAS WITH VAPORISED HYDROCARBONS.

Professor Bunte<sup>1</sup> described a number of experiments on the carburetting of coal-gas by means of various hydrocarbons, notably of gasoline (boiling at 40° C. and consisting mainly of pentane), carburine (boiling at 69° and mainly consisting of hexane), and benzene (boiling at 80°). He observed that the results of experiments on the illuminating power of the enriched gas are modified by the nature of the burner used, and by the amount of gas burned in unit time. He recommended the use of benzene as a carburetting agent, and mentioned the fact that an important source of it will be the liquid produced in the compression of oil-gas.

### AIR-GAS MACHINES AND CARBURETTORS.

Air-gas machines usually consist of arrangements for passing air over a large surface of gasoline. The liquid may be contained in a number of shallow trays, or in spongy or porous materials, curtains of flannel dipping into the spirit being sometimes employed. Occasionally the air is caused to bubble through the liquid. In all cases the carburetted air must be used as it is made, for the volatilised hydrocarbons recondense more or less on storage, and especially during passage through pipes.

The carburetting of air and the enriching of illuminating gas by hydrocarbon vapours appear to have been first proposed by Lowe (Patents No. 6179, 1831, and No. 8883, 1841), and processes for the same purpose were soon after devised by Mansfield and by Longbottom. Even when gasoline is used, fractional evaporation occurs, so that after a time the liquid remaining in the carburettor is found to be insufficiently volatile. The "metrical" carburettor of Jackson, introduced to overcome this difficulty, delivers a measured quantity of gasoline to the gas or air which passes through it, the proportion recommended by the inventor, in the case of air, being 3 to 6 gallons per 1000 cubic feet, or, in the case of gas, 1½ to 2 gallons.

In Muller's "Alpha" gas-making machine the gasoline is exposed in a number of shallow trays, over which the air is forced by a rotary blower driven by a weight attached to a cord wound round a drum. A weighted lever keeps the drum revolving while the weight is being wound up.

Weston's carburettor (Patents No. 3301, 1875, and No. 3865, 1880) (fig. 311) consists of a reservoir, A, from which the carburetting agent is supplied to a

<sup>1</sup> *Journ. f. Gasbeleuchtung*, xxvi, 442 (1893).

lower chamber, B, where a constant level is maintained. A plug, H, closes the connection between the chambers, A B, when a plug, N, is removed for charging the upper one. The chamber, B, is divided into compartments by curved plates covered with spongy material, F, which absorbs the liquid. The air or gas thus traverses a tortuous path and becomes fully carburetted in passing from the inlet, D, to the outlet, E.

In Maxim's carburettor (Patents, 1889, Nos. 703 and 2508), the gasoline or other enriching liquid is evaporated by heat, so that fractional evaporation or any variation of the amount volatilised, due to differences in temperature of the air or gas, is obviated. The amount of such evaporation is automatically adjusted according to the rate of consumption of the enriched gas. It has been found that coal-gas is enriched in this apparatus to the same extent, whether

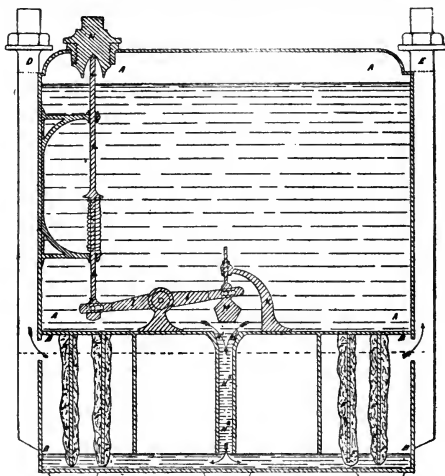

FIG. 311.—WESTON'S CARBURETTOR.

a large or small number of burners is being supplied, and that no deposition of liquid occurs when the enriched gas is cooled to  $50^{\circ}$  F.

In Maxim's improved apparatus (fig. 312) the gasoline is supplied from a reservoir at a suitable height to the upper part of a chamber, G, warmed by steam or by hot air from a ring-burner surrounding its lower part, and passes, as shown by arrows, over and through a number of perforated plates in its downward course. The upper end of the vessel is fitted with a tube, G<sup>1</sup>, terminating in a cap through which slides a tube, J, carried by a gas-holder, D, and having a series of apertures throughout its length. The air is supplied at E, to a mixing-chamber, B, having in its casing some mercury, in which the gasholder rises and falls. When the gasholder reaches a certain height, its contents pass through apertures, formed in it at a suitable level, to a chamber, A, whence they pass away at F, for consumption. As the gasholder rises with the tube, the perforations in the tube allow more or less of the gasoline vapour to enter the gasholder, so that the supply of vapour is varied according to the amount of gas used. The tube, J, is sometimes fitted, as shown, with a



similarly perforated tube,  $J^4$ , which may be adjusted angularly or longitudinally, so that the openings may be more or less closed to further regulate the supply of gasoline vapour. In another arrangement, the tubes  $J$   $J^4$  are replaced by a rod passing through the cap of the tube,  $G^1$ , and having tapering V-shaped

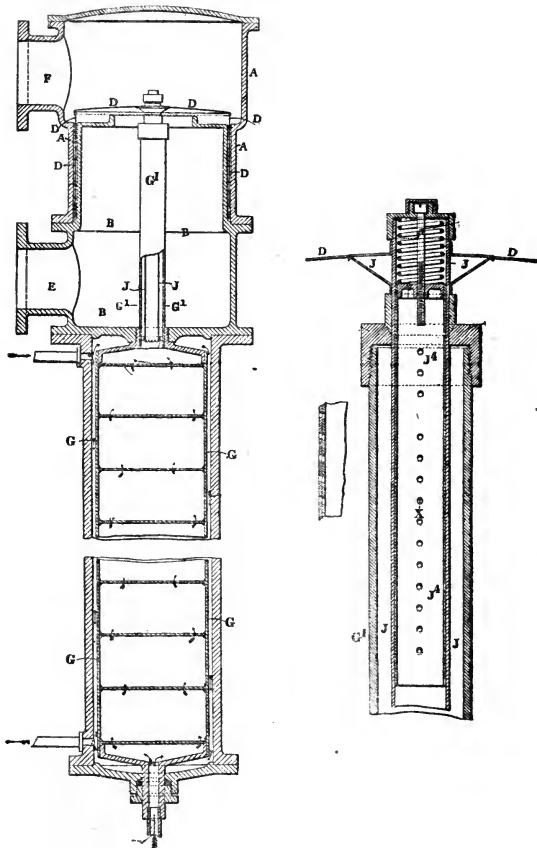

FIG. 312.—MAXIM'S CARBURETTOR.

grooves which permit passage of more or less of the vapour into the gasholder, according as their wider or narrower parts are above the cap.

Fig. 313 represents an arrangement for the employment of gasoline in increasing the illuminating power of coal-gas, patented by Maxim and Sedgwick (1890, Patent No. 2559).

The gasoline is contained in a vaporiser,  $A$ , and is converted into vapour by

steam supplied from a generator, B. The vapour may be delivered directly into the gas main, but is preferably mixed with a suitable quantity of gas drawn from the main at a convenient point, and returned to it after enrichment. The vaporiser is divided into three compartments by tube-plates,  $a^2$   $a^3$ , connected by tubes,  $a^4$ , and the hydrocarbon passes into it through a valve,  $g$ , from a raised tank. In the arrangements preferred by the inventors, the vapour produced passes out at  $e$  through a stop-cock or valve into an ejector. In escaping through the annular nozzle of the injector, the vapour draws a quantity of gas through a pipe from the main and mingles with it. The

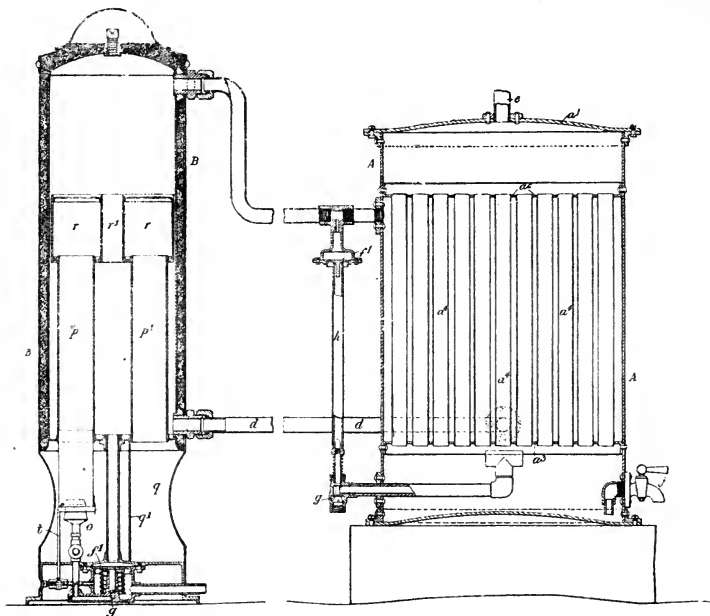

FIG. 313.—COAL-GAS CARBURETTOR.

mixture is delivered through another pipe into the main, and the gas is thus enriched to any desired extent.

The steam generator, B, consists of an upper chamber containing the water, and a lower chamber in which the heating arrangements are enclosed. The hot products of combustion from a burner,  $o$ , pass upwards through flues,  $p$   $r$ , and downwards through flues,  $r$   $p^1$ , into a chamber,  $q$ , separated by a diaphragm,  $q^1$ , from the chamber containing the burner. They finally escape through the side of the chamber,  $q$ . The flue,  $r$ , is annular, and may have a tube or tubes,  $r^1$ , passing through it to increase the heating-surface. The supply of gas to the burner is preferably regulated by a valve,  $g$ , controlled by a diaphragm,  $f^1$ , which rises or falls with any alteration of the pressure in the steam generator, B. The gas is relighted at the burner,  $o$ , by a continuously burning flame supplied from a tube,  $t$ . The steam passes into the middle chamber of the

vaporiser, and the condensed water returns to the generator, B, through a pipe, *d*.

The supply of spirit to the vaporiser is regulated by the pressure of the steam on a flexible diaphragm, *f*<sup>1</sup>, connected with a valve, *g*, on the supply-pipe, by a solid or tubular rod, *h*. Any liquid which accumulates in the vaporiser is drawn off at a cock, *j*.

Fig. 314 illustrates the "Simplex" carburettor employed with the gas-engines of Messrs. Delamare-Deboutteville & Malandin of Rouen, for producing air-gas. Petroleum spirit of specific gravity 0.65 to 0.70 is placed in a reservoir, R, and thence flows through a graduated cock, D, into a column, E, surrounded by a casing, C, heated by the hot water from the jacket of the engine-cylinder. This water has a temperature of 40° to 50° C. when it reaches the casing, C. Water from the casing falls in a light shower at F, and mingles with the spirit in the column, E. A spiral horse-hair brush, B, serves to break the oil up into spray. Each suction-stroke of the gas-engine piston, acting through a non-return valve, S, draws air through the column, E, in which it becomes saturated with the spirit-vapour. The water, dirt, and excess of spirit pass into a chamber, L, through a valve, V. An overflow-pipe, N, keeps the water at a constant level. The water is stated to be of service in facilitating the spraying of the spirit, and removing dirt.

A successful system of carburetting air is that devised by Mr. Van Friesland which is used in several places under the name of "Aerogene gas."

In this arrangement a revolving coil of pipes continually dips into petroleum spirit contained in a cylinder, and the air passed into the cylinder through the coil of pipes becomes highly carburetted by the time it reaches the outlet. The resulting gas when ignited at an ordinary burner gives a luminous flame, and can be burnt in atmospheric burners differing but little from those of the ordinary type. With an ordinary Welsbach C burner it gives a duty of about 30 candles per foot of gas consumed, the high illuminating power being due to the fact that the gas is under a pressure of 6 to 8 inches.

A complete installation of this plant was provided in the village of Breukelen (Holland), for street and house lighting. There were about two miles of mains, which in one place passed under a canal, and although it might have been expected that in cold weather there would be a serious condensation of the vapour, in practice this did not appear to be the case. It was found, however, that the rate of evaporation of the carburetting liquid was higher in the summer than in the winter, and this necessitated an adjustment of the air-supply to the burners; when once this had been made, the lighting power of the gas was uniform, and the installation worked in a perfectly satisfactory manner. Tests of the light given by the mantles, made close to the works and at a distance of half a mile away, after the gas had passed below the canal,

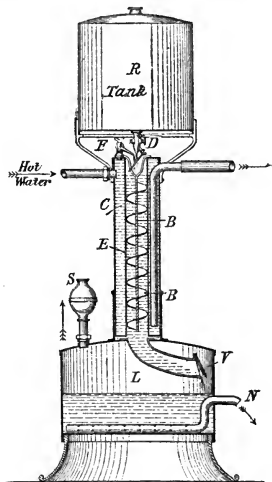

FIG. 314.—  
SIMPLEX CARBURETTOR.

showed that there was a loss of only about 1 candle per cubic foot in illuminating power during distribution.

Petrol air-gas, as it is now generally called, has made great headway during recent years. In the earlier days nearly all the systems consisted of saturating the air used with petrol vapour, and burning the mixture at a flat-flame or Argand burner with a luminous flame; when, however, the incandescent mantle had proved so great a success with coal-gas, attempts were made to use the mantle on a Bunsen burner fed with the air-petrol mixture instead of gas, and this was done by Van Friesland and others. It was found, however, that variations in the air temperature made a great difference in the amount of vapour that the air would take up, so that on a frosty evening the mixture might contain only 10 per cent. of petrol vapour, whilst on a warm summer evening it might contain 27 per cent. Such wide differences necessitated careful and constant adjustment of the air inlets to the burners, and if a sudden rise in temperature took place the usual result was blackening of the mantle.

In order to overcome this trouble, Hooker mixed petrol vapour with the full quantity of air needed for its combustion, and burnt it in the mantle without any fresh addition of air, the burner head being packed with copper wire to prevent any flashing back of the highly explosive mixture to the apparatus, and there being no air-inlets.

In reporting upon this process, Professor Lewes and the author pointed out that the mixture so made, when allowed to escape and mingle with more air, was non-explosive, the reason being that the mixture of air and petrol vapour, when it contains only 1.8 to 2 per cent. of petrol, burns with a flame hot enough to cause the incandescence of the mantle, but becomes explosive only when the petrol increases to a little over 2 per cent., then rapidly increases in explosive violence to 2.5 per cent., and afterwards loses in power until, when more than 5 per cent. of petrol is present, it again becomes non-explosive and burns quietly. It follows that if petrol air-gas containing over 5 per cent. of petrol escapes into air, it forms an explosive mixture, but if the air-gas with only 2 per cent. mixes with more air it becomes non-inflammable from excessive dilution.

This principle was soon generally adopted, the gas being often called "Safety Gas," and a large number of different forms of apparatus designed to give a mixture containing 1.8 to 2 per cent. of petrol vapour were put upon the market, the differences being in the means adopted for giving a constant carburation of the air, and the way in which the necessary power to draw in the air and create a pressure in the system is attained, falling weights, hot-air engines, and water-power being the means generally adopted.

The small percentage of petrol used enables very large volumes of the gas to be made from the petrol, as will be seen when it is considered that one gallon of petrol will yield 28 cubic feet of vapour, so that if a 2 to 1.8 per cent. mixture is made, it will represent 1400 to 1500 cubic feet. This, of course, means that the calorific value of the mixture is low, as one gallon of suitable spirit gives 134,100 B.Th.U., and when this is spread through 1500 cubic feet of the mixture it yields 89 B.Th.U. per cubic foot.

A very ingenious table-lamp for burning petroleum vapour with the incandescent mantle was devised by Mr. Legge. The lamp was furnished with a reservoir filled with sponge, or other absorbent material, which was saturated with petroleum spirit containing highly volatile hydrocarbons, and the vapour from this, descending by gravitation to the burner-head, draws in the required volume of air for its non-luminous combustion. Such a lamp gives a

light of about 40 candles when used with a mantle, and has many points of convenience and value where coal-gas is not obtainable.

### OIL-GAS.

Oil-gas is largely used as an illuminating agent, both alone and in admixture with coal-gas and water-gas : it has also been employed as a source of power in gas-engines, but naturally the oil-engine itself is more advantageous. On account of its high illuminating value, and of the fact that it suffers less deterioration on compression than coal-gas, it is employed for lighting railway trains, ships, buoys, and lighthouses. For use in buoys it is generally compressed to about 10 atmospheres, when it loses about 10 per cent. of its illuminating power from the condensation of the less volatile hydrocarbons, but still gives a light of 40 to 50 candle-power.

For the lighting of railway carriages it appears to have been first used in 1871 on the Silesian railways, and in 1876 it was introduced on the Metropolitan Railway. According to Mr. Thompson, the use of oil-gas on the Metropolitan Railway was found to be cheaper than that of coal-gas.

The first oil-gas producer was made in England in 1815 by Taylor (Patent No. 3929), the gas being prepared by passing vegetable and other oils through highly heated pipes, but lighting by compressed oil-gas was proposed as early as 1792 by Murdoch. Faraday<sup>1</sup> examined the gas and by-products obtained by the process patented by Gordon and Heard (No. 4381, 1819) for producing a compressed portable gas.

In the manufacture of oil-gas the oil is slowly delivered into a retort heated to cherry-redness, and is thus converted into permanent gas. The illuminating power of the gas depends upon the temperature of the retort, more gas being obtained when the retort is highly heated, but the product being of lower lighting-value.

The colour of the gas, at the time of production, should be nut-brown, and the tar from the hydraulic main should not exhibit a greasy margin when dropped on white paper. If the oil be supplied to the retort too freely, or if the temperature of the retort be insufficiently high, the gas will be light brown or white in colour, and the greasy margin referred to will be formed ; whilst, on the other hand, if too little oil be passed into the retort, or if the temperature be too high, the colour of the gas will be dark brown, and flakes of soot will be discernible.

On leaving the retorts the oil-gas passes into a main filled with water which removes the bulk of the tarry matters. Thence it flows, after further washing and cooling, into the gas-holder. This purifying process is sufficient for gas used in engines, but when required for lighting purposes, the gas passes from the hydraulic main, through a water washer, and thence over a mixture of two parts of slaked lime and one part of sawdust. Having thus been freed from sulphur compounds, carbonic acid, etc., it is stored in a gas-holder, and is thence pumped into portable receptacles at a pressure of 10 atmospheres.

In Great Britain oil-gas was formerly made from the "gas-oil" obtained in the distillation of Scotch shale. This oil, which is intermediate between the burning and lubricating oils in respect to boiling-point and density, has a specific gravity of 0.84 to 0.87. Subsequently, however, an intermediate Russian oil, known as solar-oil distillate, gas-oil imported from the United States, Rumania, and Galicia, and ordinary kerosene, were used for the purpose by the gas companies. Mr. Donkin states that "in other countries various

<sup>1</sup> *Phil. Trans.*, 440 (1825).

substances are successfully distilled to produce oil-gas, such as linseed oil in Brazil, castor oil in Burma, palm oil in West Africa, mutton-fat in Australia and South America, and, in general, fatty refuse of all kinds wherever it is found in abundance."

The tar obtained in the manufacture of oil-gas amounts to about 5 gallons per 1000 feet, and is burned under the retorts. The liquid obtained by the compression of the gas contains from 24 to 65 per cent. of benzene and toluene,<sup>1</sup> and is rich in normal olefines, but is practically free from paraffins. It amounts to about 1 gallon per 1000 cubic feet.

Pintsch's oil-gas plant (Patents 1873, No. 3101; 1876, No. 4514; and 1883, No. 4976), largely used for making gas for buoys, lighthouses, etc.,

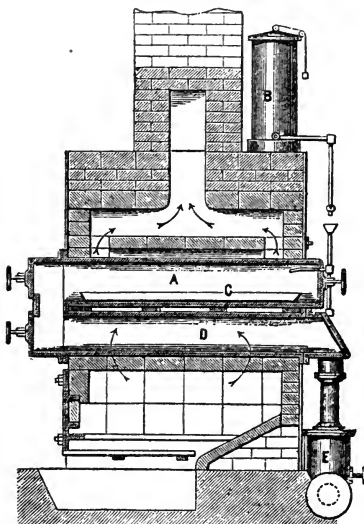

FIG. 315.—PINTSCH'S OIL-GAS PLANT.

is represented in fig. 315. The retorts are of cast iron and  $\Omega$ -shaped, the largest size being 6 feet 2 inches to 6 feet 4 inches long, 10 inches wide, and  $9\frac{3}{4}$  inches deep. They are heated to a bright cherry-red, and are worked in pairs, one being set above the other. The oil is run from a reservoir, B, into the upper retort, A, at one end, where it falls upon an iron tray, C, and the vapour passes into the hotter retort, D, beneath, where it becomes gasified. The gas passes through a tar-separator, E, into the hydraulic main, and is further purified in the manner already described, about 80 cubic feet of gas being obtained per gallon of oil. The pressure in the retorts amounts to about 3 or 4 inches of water.

The Keith plant (fig. 316) was the first applied to the production of oil-gas for use in motors on the large scale. Installations were provided at Langness Point, in the

Isle of Man, and on Ailsa Craig Rock, in the Firth of Clyde, for driving Crossley engines in connection with the fog-signalling apparatus. The central portion of the retorts is constructed as shown, and the oil is delivered into shallow cast-iron gutters, along which it flows into the hotter parts of the retorts, where it becomes gasified.

For small installations, Mr Keith has introduced a double retort which is of V-shape in plan and of the ordinary  $\Omega$ -shape in section.

Fig. 317 represents the Mansfield producer, in which oil-gas may be made from any kind of oil or fat as well as from paraffin-oils. The oil or fat in the vessel, A, runs continuously into a siphon pipe, S, thence passing into a retort, R, which is heated to a cherry-red. The retort is surrounded by a cast-iron casing, C, lined with firebrick, L. The supply of air and the discharge of the products of combustion are regulated by dampers, M D. The oil is not supplied to the siphon, S, until the retort is fully heated, as seen through

<sup>1</sup> Greville Williams, *Chem. News*, xlix, 197 (1884).

an opening, *p*. The gases pass through the retort-hood, *B*, and down a stand-pipe, *P*, to the hydraulic box, *H*, whence, after being purified from tar, they escape at *Q* to the gasholder. *N* is a door through which the tar is withdrawn from the box, and *V* a safety-valve. The hood, *B*, rests upon

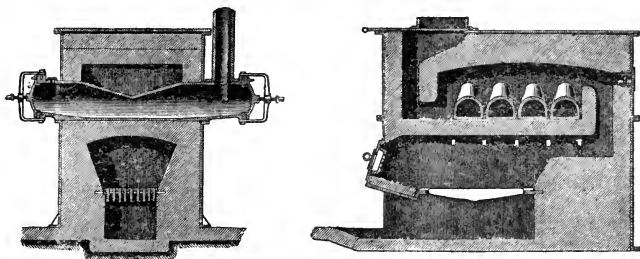

FIG. 316.—KEITH OIL-GAS PLANT.

two sockets, *O K*. One of these (*K*) forms a water-seal through which the gas escapes in the event of excessive pressure occurring. The other (*O*) is filled with lead which melts with the heat, the hood sinking into it, a gastight joint being thus formed. The temperature of the vessel, *A*, is sufficiently high to liquefy solid fats. †When worked with “intermediate” oil, from 7 to 9½ gallons of oil is used per 1000 feet of gas.

In the Thwaite plant (fig. 318) the generator consists of an iron retort enclosed in a slow-combustion chamber, the heating being effected by the combustion of coke. The oil trickles into the retort down a central tube, and the vapour passes up between the tube and the sides of the retort, the permanent gas thus formed being conducted away at the top to a condenser, and thence to an oxide of iron purifier.

Mr. J. F. Tocher<sup>1</sup> gives the results of a number of experiments on the production of oil-gas. Table CLVII shows the nature of the products from various oils, the cracking of the oils being carried out in a cylindrical iron retort 36 inches by 6 inches.

These results indicate that the temperature which produces gas of the highest illuminating power lies between 800° and 850° C., which is said to be much lower than that employed in the Pintsch and Keith oil-gas retorts, and that the higher temperatures tend to produce free hydrogen at the expense

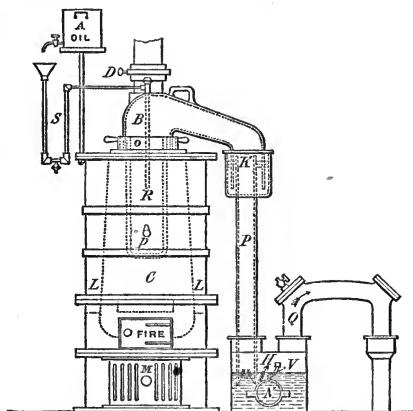

FIG. 317.—MANSFIELD OIL-GAS PRODUCER.

<sup>1</sup> *Journ. Soc. Chem. Ind.*, xiii, 231 (1894).

of the heavier, light-giving hydrocarbons. The results recorded in Table CLVIII are also of interest in this connection. The experiments on octane and decane were performed in a cylindrical iron retort 8 inches long and

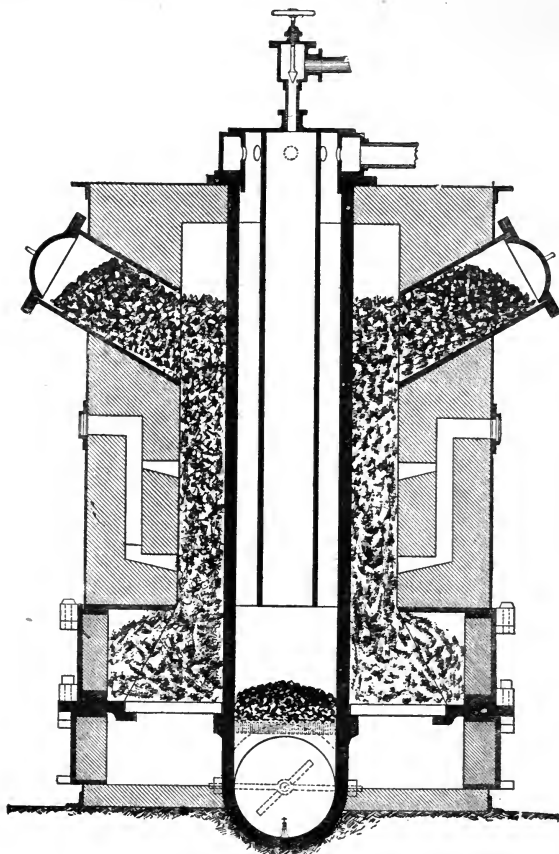

FIG. 318.—THWAITE OIL-GAS PLANT.

3 inches in diameter, while the turpentine was decomposed in an iron retort 36 inches long and 6 inches in diameter.

Mr. Tocher observes that the larger proportion of unsaturated hydrocarbons is found in the gas produced from oils mainly composed of the higher members of the olefine series, and states that the Scotch mineral oils must therefore be the best for manufacturing oil-gas, and Russian oil better than American.

The use of oil-gas for railway-carriage lighting has greatly increased of late



TABLE CLVII.—PRODUCTS YIELDED BY VARIOUS OILS.

Temperature.	Mineral Naphtha. Sp. gr. 0.730.		Burning Oil. Sp. gr. 0.807.		Mineral Oil. Sp. gr. 0.847.		Mineral Oil. Sp. gr. 0.884.			
	600° C.	850° C.	600° C.	850° C.	600° C.	800° C.	1100° C.	500° C.	600° C.	850° C.
Cubic feet per gallon of oil, . . . . .	72	100	75	93	64	82	95	34	59	108
Colour of gas, . . . . .	White	White	White	Brownish-white	White	Light brown	Dark brown	Light yellow	Light yellow	Brown
Composition of gas— $C_nH_n$ hydrocarbons, . . . . .	Per cent. 31.2	Per cent. 29.8	Per cent. 32.8	Per cent. 43.1	Per cent. 33.7	Per cent. 46.2	Per cent. 21.5	Per cent. 44.7	Per cent. 40.5	Per cent. 35.7
$C_nH_{2n+2}$ hydrocarbons, . . . . .	47.6	48.7	57.0	47.2	50.1	39.4	49.2	40.1	48.2	46.3
Hydrogen, . . . . .	17.4	19.1	7.1	7.6	13.7	11.9	28.4	12.7	8.1	16.1
Carbon density of $C_nH_n$ , . . . . .	2.67	2.71	3.93	2.92	2.88	2.75	2.41	3.11	2.95	2.79
Hydrogen density, . . . . .	..	..	..	..	4.87	5.22	5.16	5.38	5.54	4.46
Illuminating power— In candles corrected to 5 cub. ft. of gas and 120 grains sperm per hour.	43.5	42.2	48.7	61.4	52.5	64.8	36.2	63.8	57.7	49.0
Candles per gallon, . . . . .	626	844	730	1142	672	1062	688	434	681	1058
Pounds sperm per ton, . . . . .	3292	4437	3482	5447	3046	4815	3119	1885	2958	4596
Enriching value, pounds sperm, . . . . .	..	..	..	6 per cent. mixture gave 10,174 Enrichment figure = 118.	..	5 per cent. mixture gave 6872 Enrichment figure = 96.5.	..	..	..	..
Percentage of residuals, . . . . .	11.4	5.1	21.4	7.5	28.5	12.2	18	62.3	41.5	9.4

TABLE CLVIII.—PRODUCTS YIELDED BY VARIOUS HYDROCARBONS.

Temperature.	Octane, $C_8H_{18}$ . Boiling-point, 122° C.		Decane, $C_{10}H_{22}$ . Boiling-point, 156.5° C.		Turpentine Oil. $C_{10}H_{18}$ . Boiling-point. 154°-158° C.		Naphtha, 0.730.		Mineral Oil, 0.884.	
	550° C.	800° C.	550° C.	800° C.	800° C.	800° C.	850° C.	850° C.	500° C.	850° C.
Yield, . . . . .	18 litres per 100 c.c.	42 litres per 100 c.c.	24.6 litres per 100 c.c.	47.5 litres per 100 c.c.	63.3 c.f. per gall.	100 c.f. per gall.	34 c.f. per gall.	0.108 c.f. per gall.		
Colour of gas, . . . . .	White.	White.	White.	White.	White.	White.	Light yellow.	Brown.		
Composition of gas— $C_nH_n$ hydrocarbon, . . . . .	23.5	12.3	27.4	13.4	19.1	29.8	44.7	35.7		
$C_nH_{2n+2}$ hydrocarbon, . . . . .	39.4	35.4	36.0	50.1	54.1	48.7	40.1	46.3		
Hydrogen, . . . . .	35.7	52.8	35.7	36.5	26.8	19.1	12.7	16.1		
Ethylene equivalent of $C_nH_n$ , . . . . .	30.0	11.7	32.1	14.2	30.4	35.2	69.5	49.8		
Carbon density, . . . . .	2.56	1.91	2.35	2.12	3.20	2.71	3.11	2.79		
Illuminating power, in candles per 5 cubic feet, . . . . .	18.0	..	20.2	12.0	39.1	42.2	63.8	49.0		
Residuals, per cent., . . . . .	22.0	A few drops.	50.0 Composed almost entirely of unchanged decane.	None.	16.6	5.1	62.3	9.4		

years, owing to the introduction of the inverted incandescent mantle. A very small volume of oil-gas consumed in an atmospheric burner yields a very fine light with the mantle, but the early experiments led to but little success owing to vibration rapidly destroying upright mantles; when, however, the inverted mantle was introduced, it was found that the suspension of the mantle by the fire-clay rings and lugs, by which it is hung on to the nozzle of the burner, acted as an anti-vibrator, and the specially designed roof-burners, used by Pintsch, give an excellent light with the consumption of less than a cubic foot of oil-gas per hour.

In the Blau process, oil-gas is made in a Pintsch retort at a slightly lower temperature than is usually employed,  $600^{\circ}$  to  $700^{\circ}$  C. being used instead of  $800^{\circ}$  to  $900^{\circ}$  C. Under these conditions a smaller volume of slightly richer gas is made, and this undergoes a preliminary compression to free it from benzene, toluene, hexane, and heptane; after these have separated, compression is carried up to 100 atmospheres, when ethane, butane, iso-butane, propane, pentane, propylene, and butylene separate as a liquid, and under pressure dissolve ethylene and other gases which could not be liquefied by pressure without cooling to a low temperature.

The less soluble gases are then drawn off, and the liquid gases holding the more soluble gases in solution are stored in strong steel cylinders, these liquid gases again assuming the gaseous form on the pressure being relieved.

The great advantage of the process is that it enables the richest portion of the oil-gas to be obtained in a portable form for carriage, the drawback being that a smaller initial volume of gas is made per gallon of oil decomposed in the retort.<sup>1</sup>

**Carburetted Water-Gas.**—At one time when legal enactments required that coal-gas should have a minimum illuminating value, *i.e.* "candle-power," this minimum could not be economically obtained with many of the ordinary gas coals, and a proportion of cannel coal was carbonised with the gas coal, the former yielding gas of much higher illuminating value. But the supplies of suitable cannel diminished, and its price rose, so that it became more economical to use a mixture of water-gas with oil-gas, the mixture being known as "carburetted water-gas."

The position has, however, materially changed since the introduction of the incandescent mantle, direct illuminating power of the gas no longer having its former importance. Heating power of the gas is now of more primary importance, and has been substituted for candle-power in recent English legislation. Present-day carburetted water-gas is made to supplement the make of coal-gas, and for this purpose need have no higher illuminating power, and a calorific value of 500 B.Th.U. per cubic foot (practically that of coal-gas) can be obtained by gasifying about 2 gals. of oil per 1000 cubic feet of water-gas produced. In America carburetted water-gas is, however, supplied in many districts for the usual purposes for which coal-gas is used in this country. For the enriching of water-gas the oil-gas is usually produced by passing the water-gas with the vapour of the oil through superheaters, as in the Lowe, Springer, and other processes originally used in the United States and elsewhere. Since its introduction into England in 1890 the use of carburetted water-gas extended very rapidly.

<sup>1</sup> Further information on the production and use of oil-gas will be found in the following publications:—*Journal of Gas Lighting*; Robinson (Cantor Lectures, 1892); Ayres (*Proc. Inst. Civ. Engineers*, xxiii, 298–363); Donkin (*Gas, Oil, and Air Engines*); Armstrong (*Journ. Soc. Chem. Ind.*, iii, 562, 1884), and Thorpe's *Dictionary of Applied Chemistry*; Lewes (Cantor Lectures, 1890). The water-gas plant at the Belfast Gas Works was described by J. Stelfox before the Incorporated Gas Institute in 1894 (*Trans. I.G. Inst.*, 1894, 82).

In the Lowe process, as described by Professor Lewes,<sup>1</sup> coke or anthracite is heated by an air-blast to incandescence, in a generator lined with firebrick, the heated products of combustion, as they leave the generator and enter the superheaters, being supplied with more air, which causes the combustion of the carbon monoxide present in the producer-gas, and heats up the firebrick baffles with which the superheaters are filled. When the necessary temperatures of the fuel and superheaters have been reached, the air-blasts are cut off, and steam is blown through the generator, forming water-gas, which meets the enriching oil at the top of the first superheater, called the carburettor, and carries the vapours with it through the main superheater, where the "fixing" of the hydrocarbons takes place. The chief advantage of this apparatus is that the enormous superheating space enables a lower temperature to be used for the "fixing." This does away, to a great extent, with the too great breaking-down of the hydrocarbons, and consequent deposition of carbon.

In a description of the Lowe process as used at Beckton, Mr. T. Goulden<sup>2</sup> stated that there were twelve generators capable of producing 6 million cubic feet of carburetted water-gas daily, and actually producing about 5 million feet per day. The efficiency of the gas obtained was, at the time of publication, 1082 candles per gallon of "Russian distillate" used, and the gas was employed to the extent of about 10 per cent., for enriching ordinary coal-gas. The coal-gas might be considered to contain 4 per cent. of carbon monoxide, while the mixed gas issued to the consumer contained about 10.5 per cent.

In the Springer process, which differs from the Lowe only in the construction of the apparatus, the superheater is directly above the generator, and there is only one superheating chamber instead of two. The air-blast is admitted at the bottom, and the producer-gases heat the superheater in the usual way. When the required temperature is reached, the steam is blown in at the top of the generator, and is made to pass through the incandescent fuel, the water-gas being led from the bottom of the apparatus to the top, where it enters at the summit of the superheater, meets the oil, and passes down with it through the chamber, the finished gas escaping at the middle of the apparatus.

The form of carburetted water-gas generator which has been most employed in England is the Lowe type, and there are now few large gas-works in this country which have not a water-gas plant as a stand-by in case of any sudden demand on their production; whilst in London, north of the Thames, the gas-supply contains on an average 25 per cent. of carburetted water-gas. The fluctuation in the quality and price of oil suitable for carburetting has of late been a source of considerable trouble, and this in conjunction with the general tendency to reduce the illuminating power of the gas has checked the erection of new plants.

The chief factor in the success of the Lowe type of carburetted water-gas plant is the thorough and efficient utilisation of the hot producer-gas, made during the "blow," in heating by its combustion the chamber filled with brick chequer-work in which the oil is gasified in presence of the stream of hot water-gas; and although rapid advances have of late been made in the production of "blue-oil" water-gas by the Dellwik system, the Lowe type of plant still retains its supremacy when used for making carburetted water-gas—*i.e.* for the dual purpose of making water-gas and utilising the waste heat for the gasification of the oil that is to give it luminosity.

Fig. 319 illustrates an arrangement introduced by Mr. Thwaite for making enriched producer gas of constant quality, usually of about the same heating

<sup>1</sup> Cantor Lectures, 1890.

<sup>2</sup> *Journ. of Gas Lighting*, lxi, 939 (1893).

power as ordinary coal-gas. The figure represents the installation in use at the Southall Gas Works of the Brentford Gas Corporation. There are two producers which are automatically and regularly charged with coke or anthra-

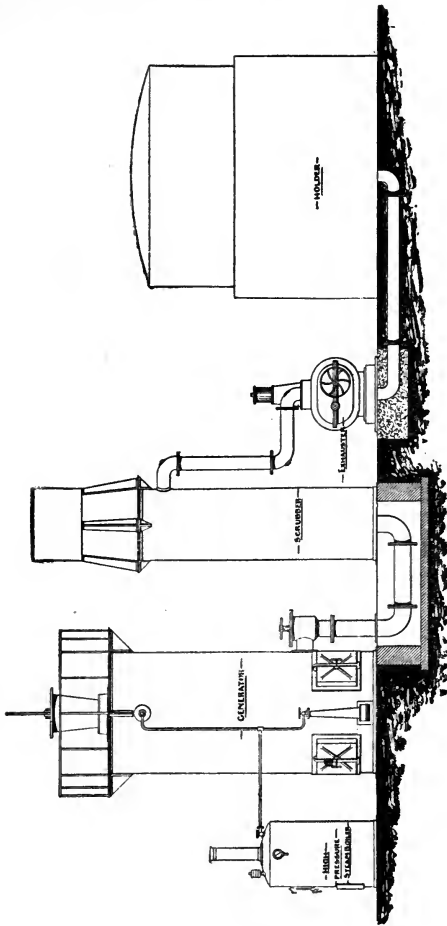

FIG. 319.—THWAITE GAS PLANT.

cite, and are used alternately. The products of combustion in one producer are drawn through a flue into the other, in which they are converted by passage through its incandescent fuel into hydrogen and carbon monoxide. These gases are collected in a separate holder, or are used for diluting the final product. After a proper interval, the direction of the gases is reversed by automatic valves, and after four reversals, the air, which has raised the fuel to incandes-

cence is shut off, and oil is sprayed in by a steam injector at the upper part of one of the producers. The oil-vapour passes with the steam through the incandescent fuel in the other producer, and is there converted into permanent gas in admixture with the water-gas produced by the decomposition of the steam by the fuel. When the temperature of the fuel falls too low, the oil is shut off, and the fuel is reheated by admitting air.

Messrs. W. Young and A. Bell (Patents, 1892, No. 12,421, and 1893, No. 12,355) introduced a system (generally known as the Peebles process) of manufacturing oil-gas, which was employed at the Galashiels Gas Works for the direct enrichment of coal-gas. The plant is represented in fig. 320, which is taken from the *Journal of Gas Lighting*, 1893, p. 265. The retorts used were of cast iron, of cylindrical form, and larger than those employed for making coal-gas. They were 9 feet long and 27 inches in internal diameter, and were slightly inclined, as shown. The oil-retorts and the ordinary coal-retorts, A, were set back to back, and the former heated at C by the gas from a "semi-producer," which furnished the heat required for the carbonisation of the coal. The front of each oil-retort had a mouthpiece, B, with a circular door and an off-take pipe communicating by pipes, D, with

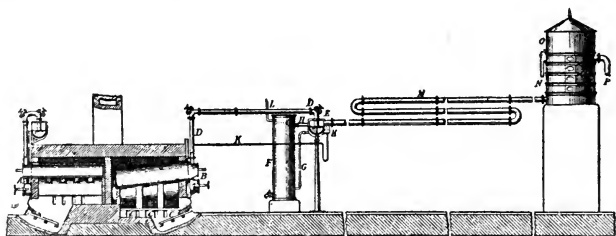

FIG. 320.—PEEBLES GAS PLANT.

the hydraulic main, E. From the condenser, M, the gas passed to the scrubber, N, above which was a cistern, O, containing the oil used for scrubbing. The compensating and settling tank is shown at F, the oil-outlet from the hydraulic main at G, the main oil-feeding pipe at H, the regulating-valve and siphon pipe at K, and the fresh-oil supply-pipe and ball-cock at L. At Galashiels, "blue-oil" of specific gravity 0.885 was used, the temperature of the retort from 1200° to 1300° F., the interior temperature in the centre of the retort being about 900° to 950° F. The temperature, however, varied with the nature of the oil, being much higher for blast-furnace oil and coal-tar.

The oil was allowed to enter the retort at such a speed that it was not wholly converted into permanent gas, but in part was vaporised only. The arrangement adopted was said to result in a fractional vaporisation of the oil as it passed from end to end of the retort, and in the subjection of the vapours to gradually increasing temperatures. The inflowing oil removed soot, etc., from the gas issuing from the retort. The gas on leaving the scrubber was mixed with the low-quality coal-gas at the inlet of the purifiers. The coke from the oil-retorts was hard, dense, and almost free from sulphur. The plant is, of course, applicable for the manufacture of oil-gas for use otherwise than in admixture with coal-gas, and the drawing merely shows an arrangement (very different from that figured in the patent specification) well adapted for a gas-works.

TABLE CLIX.—OIL-GAS AND COAL-GAS IN VARIOUS PROPORTIONS.

Percentages.		Candles observed	Rate.		Candle-power at 5 cubic feet per hour and 120 grains Sperm.	Theoretical Figure for the Mixture, calculated from Observed Candle-power of separate Gases, $p_3 \frac{(\gamma \times P_1) + (y \times P_2)}{100}$	Enrichment Figure found = Intrinsic Illuminating Value of Oil-Gas. $p_1 = \frac{y(P_3 - P_2) + P_3}{\%}$	Increase in Candle-power per cent. of Oil-Gas taken. $C_1 = \frac{P_3 - P_2}{\%}$
Oil-Gas.	Coal-Gas.		Gas per hour.	Grains Sperm per hour.				
100	..	11.22	2.08	117	52.5	..	..	
..	100	10.40	5.00	115	19.5	..	..	
75	25	10.25	2.30	125	46.4	44.2	0.36	
60	40	10.84	2.55	121	42.9	39.3	0.39	
40	60	7.40	2.12	118	34.2	32.7	0.37	
20	80	9.32	3.02	117	29.9	26.1	0.52	
13	87	11.94	4.42	122	27.4	23.8	0.62	
100	..	..	..	..	57.7	..	..	
..	100	..	..	..	20.5	..	..	
5	95	12.4	5.00	118	24.3	22.3	0.76	
100	..	..	..	..	61.4	..	..	
..	100	..	..	..	20.5	..	..	
6	94	10.5	4.01	121	26.2	22.9	0.95	

Mr. J. F. Tocher<sup>1</sup> gives the results in Table CLIX, for experiments in enriching coal-gas with various proportions of oil-gas.

Laboratory investigations of various oils used for carburetting water-gas have been carried out by R. Ross and J. P. Leather.<sup>2</sup> These authors conclude that since the illuminating power is dependent on the quantity of hydrocarbon vapours and of the "heavy hydrocarbons" the relative value of oils may be approximated from the product of the total volume of gas in c.c.'s per gram of oil into the volume of heavy hydrocarbons (*i.e.* those absorbed by fuming sulphuric acid). This product is termed the "valuation figure." Further, from the results of fractionation tests with determinations of the specific gravity and refractive index of the original oils and the fractions, the conclusion is drawn that the lower the gravity and refractive index the better the oil for gas-making.

Comparisons are given between laboratory and works tests, the value of American oil being taken as standard and equal to 100.

TABLE CLX.

Oil.	Laboratory.		Works.	
	Valuation Figure.	Relative Value.	Candles per Gallon per 1000 Cubic Feet.	Relative Value.
American, . . . .	16,000	100.0	8.90	100.0
Russian, . . . .	15,927	99.5	8.73	98.1
Texas, . . . .	11,697	73.1	6.20	70.3
Borneo, . . . .	8,024	50.1	4.69	52.7

The effect of various atmospheres on the cracking of oils for gas-making has been investigated by Downing and Pohlman.

In hydrogen the highest heat units in the gas were obtained, due to abnormal production of saturated hydrocarbons; hydrogen was found to be absorbed. The most effective illuminating values were obtained in a methane atmosphere. With the inert nitrogen atmosphere there was appreciable formation of free hydrogen, and increased tar and free carbon were formed. Carbon monoxide atmospheres appear to lead to the formation of maximum tar, but prevented the decomposition of illuminants. More olefines appear to be formed, the gaseous members enhancing the illuminating power, the heavier liquid olefines increasing the tar. The ordinary "blue" gas from the generators gave such good results that no advantage would accrue in other atmospheres; at 750–780° C. the maximum light yielding constituents per gallon of oil were formed. Excess of steam in the water-gas was shown to be detrimental.

### NATURAL GAS.

The composition and production of natural gas has been dealt with in a preceding section (vol. i, pp. 342–346) and statistics of production will be found in this volume.

Many million cubic feet are marketed annually in the United States, and the gas is employed for illumination (most economically in conjunction with the

<sup>1</sup> *Journ. Soc. Chem. Ind.*, xiii, 231 (1894).

<sup>2</sup> *Journ. Soc. Chem. Ind.*, 676 (1902). *Analyst*, xxxi, 284 (1906); xxxii, 241 (1907).



incandescent mantle) and for domestic heating, and industrially on a very large scale for many operations requiring high furnace temperatures, such as the brick, glass, cement, iron, and zinc industries. It is also employed for power production, gas-engines suitable for its use being widely installed throughout the gas belt. An important development in the industrial use of natural gas which was started about the year 1909 was the extraction of petrol (*natural-gas gasoline*) from gas of suitable composition. Natural gas is also employed for making lamp-black, and at one time even for the production of a coke product similar to the retort carbon of the coal-gas plant, but this wasteful use is now obsolete.

For many years natural gas was employed in a most wasteful manner, according to J. Leo Henderson.<sup>1</sup> The investigations of A. J. Diescher early in 1915 showed the waste of gas to be no less than 340,000,000 feet, or 8000 long tons a day; and J. C. M'Dowell had estimated that the value of the gas wasted during recent years exceeded that of the whole petroleum production.

This waste appears to have been attributable to two main causes: wasteful extravagance by the consumer because companies supplied at a fixed price

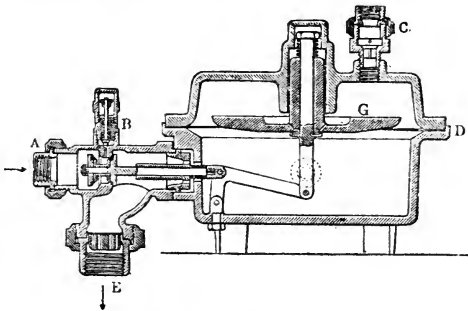

FIG. 321.—WESTINGHOUSE GAS REGULATOR.

per month, based upon the number of burners and fires in use, with the result that the gas was usually kept burning day and night in the cold season, and waste in distribution through leakage in the pipe-lines.

The introduction of the meter system, although it involved a large capital expenditure, largely increased the companies' revenues and made consumers more careful. Of scarcely less importance is the waste underground through leakage into strata above the gas-sands owing to imperfect casing and packing. Leakage from the pipe-line system is also serious; this loss being largely attributed to the action of condensates (the gasoline) on rubber gaskets and to corrosion of the mains. J. C. M'Dowell has put this loss as amounting to 25 to 40 per cent. of the gas delivered into the mains at the fields, but this loss may be reduced by the adoption of a comprehensive system of reducing the initial pressure of the gas, so as to diminish loss by leakage, the positions of the gas-regulators being so chosen as to equalise the pressure throughout the service. Fig. 321 shows the Westinghouse regulator. The gas enters from the main at A, and passes to the service-pipe at E, through a piston-valve connected with a weight, G, on a diaphragm in a casing to which the gas has access round the rod of the piston-valve. If the pressure becomes too great,

<sup>1</sup> "The Natural Gas Industry," *Journ. Inst. Pet. Techs.*, ii, 204 (April 1916).

the diaphragm carrying the weight is raised, and the piston-valve being thus partially closed, the passage into the service-pipe is controlled. If the pressure be excessive, the valve is wholly closed until the pressure has been reduced, the gas meanwhile escaping through a safety-valve, B.

Natural gas is distributed to the consumer in wrought-iron pipes, ranging in diameter from 2 inches up to 20 inches. The pressure is sometimes as high as 400 lbs. to the square inch, but usually reaches from 200 to 300 lbs. where the diameter is not over 10 inches. Riveted wrought-iron pipes 3 feet in diameter are also used. The most common method of distribution in cities and towns is by a series of pipes from 12 inches down to 2 inches in diameter, usually carrying a pressure of about 4 ounces to the square inch. To these pipes the service-pipes leading into the houses of the consumers are connected. This low-pressure system is fed at numerous points by a series of automatic regulators connected by lines which carry a pressure usually ranging from 20 to 50 lbs. to the square inch. Another system of distribution is that of placing inside or near each house a reducing-valve connected to a smaller pipe carrying a higher pressure. The total number of feet of pipe of all sizes between 2 inches and 36 inches in diameter used in conveying and distributing natural gas up to the close of 1903 was 28,283 miles.

### GASOLINE FROM NATURAL GAS.

Certain of the petroleum natural gases have long been known to carry the vapours of paraffin hydrocarbons which became condensed to the liquid form under suitable conditions, such as the compression when the gas was pumped into distributing mains. From this deposition such gas was known as "wet gas" and the easily liquefied products consisted mainly of pentane and hexane. Such wet gas is produced chiefly from oil-wells and is known also as "casing-head gas." Owing to the presence of the liquefiable vapours the density of the gas is frequently as great as that of air, and may be as high as 1.5. The density affords a rough approximation of the quantity of liquefiable products present.

The proportion of gasoline in the gas will be largely dependent upon the character of the oil with which it is associated, other factors influencing the quantity will be the intimacy of contact between the gas and oil, and the temperature and pressure conditions.

"Dry gas," on the other hand, is practically free from condensable hydrocarbons and is derived principally from gas accumulations which may not be associated with any quantity of liquid oil. Consisting principally of methane and ethane, its density is well below that of air.

Whilst at the extremes definitely "wet" and "dry" gas are recognised, all gradations between these are met with, and the character of a gas frequently undergoes marked change as the pressure in the well falls.

Thus at high pressures, particularly where the gas is associated with oil in the strata, readily liquefied hydrocarbons remain in the oil, but as the pressure is reduced a higher proportion of these appears in the gas, which may become definitely "wet" gas. When gas has actually to be drawn off by suction and then passed into mains under pressure, it follows that condensable hydrocarbons will assume the liquid conditions.

B. Rozanski<sup>1</sup> says that the richest American gas yields 106 litres per 100 cubic metres (about 6.6 imperial gallons per 1000 cubic feet), the average yield being 40-46 litres (about 2.5-2.9 imperial gallons per 1000 cubic feet).

<sup>1</sup> *Petr.*, ix, 217-224 (1913).

Singer<sup>1</sup> gives the extreme range of specific gravity of the gasoline products as 0.590-0.724.

Accumulations of these liquefied products in the distributing mains has to be dealt with, and Passenmeyer and others collected this gasoline in commercial quantities near Titusville, Pa., in 1904. Besides mechanical problems associated with the accumulation of liquids in the mains, serious trouble may be experienced through their action on rubber, which is commonly employed in making the joints.

The provision of suitable appliances for the removal of condensable products from the gas prior to its discharge into the mains naturally was quickly developed, an additional incentive being found in the growing demand for petrol, and there has been a rapid development in the production of natural-gas gasoline in the United States, and in Canada. Statistics relating to this development are shown in Table CLXI.

TABLE CLXI.—PRODUCTION OF GASOLINE FROM NATURAL GAS IN THE UNITED STATES.

Year.	Number of Plants.	Quantity of Gas treated, Cubic Feet.	Gasoline produced, Gallons (American).
1911	176	2,495,697,000	7,425,839
1912	250	4,687,796,000	12,081,179
1913	341	9,839,441,000	24,060,817
1914	386	16,894,557,000	42,652,632
1915	414	24,000,000,000	63,364,665
1916	594	203,800,000,000	104,212,809
1917	...	429,300,000,000	217,900,000

(1 American gallon = 0.833 imperial gallon.)

In 1915 the "blend" of casing-head gasoline with heavier naphthas represented nearly 10 per cent. of the total gasoline output. Not only is this recovery of liquid products economically sound, in furnishing additional supplies of petrol directly, but it also furnishes more volatile liquids which can be employed for blending with heavier naphthas to render them suitable for fuel for internal-combustion engines, and still more volatile products which can only be stored in steel cylinders under pressure as "liquefied gas" or "gasol." A secondary result is that trouble with jointing material in the mains is largely reduced.

Three methods of extraction are employed:—(1) compression, with cooling to assist condensation; (2) refrigeration by low temperatures, such as can be obtained with liquid ammonia; (3) washing with a heavy oil, with subsequent recovery of the volatile spirit by distillation, or washing with a suitable naphtha which thus becomes sufficiently "enlivened" for direct use in engines.

The compression method was that first employed, and is still the one in most general use. In the early days compression in a single stage to yield a light gasoline was alone practised, but development into two stages, and, finally, three stages in some cases, quickly followed. Only a decidedly "wet" gas can usually be economically treated, a yield of about 0.75 gallon of gasoline per 1000 cubic feet of gas being generally regarded as the lower limit for economical working.

<sup>1</sup> *Loc. cit.*, ix, 453 (1914).

The composition and character of the liquid product is dependent upon the pressure employed, *i.e.* upon the ease of liquefaction of the gases. Physical data for the lower members of the paraffin hydrocarbons is given in Table CLXII. Unfortunately the data on critical temperature and pressure for butane are not available.

TABLE CLXII.—BOILING-POINT, CRITICAL TEMPERATURE AND PRESSURE OF LOWER PARAFFIN HYDROCARBONS.

Name.	Boiling-point °C.	Density.	Critical Temperature °C.	Critical Pressure Atmospheres.
Methane, . . . . .	-160	...	{ -95.5 *	50 *
Ethane, . . . . .	-93	...	{ -81.8 †	54.9 †
Propane, . . . . .	-37	...	35	45.2
Butane (normal), . . . . .	+ 1	...	97	44.0
Butane (trimethyl methane), . . . . .	- 17	0.60(?)	...	...
Pentane (normal), . . . . .	+ 37	0.6283/17°	197.2	33.0
Pentane (iso-normal), . . . . .	+ 30	0.6385/14°	188.0	33.0
Hexane (normal), . . . . .	+ 71.5	0.6330/17°	234.8	30.0

\* Dewar.

† Olszewski.

First-stage compression is usually to about 3.5 atmospheres, and the product ranges in density from 0.672 to 0.700. From some of the western fields (U.S.) a higher density of 0.720 is reached. In Galicia still higher densities, 0.730 to 0.770, are stated to be obtained. The liquid product is mainly pentane and hexane, and as these liquids have a high solvent action, especially under pressure, for less easily condensed hydrocarbons, butanes in small amounts are present, and possibly some propane. On exposure to air the more volatile products escape, and a process of "weathering" in open vessels is necessary, otherwise undue pressure would be set up in storage vessels. Considerable loss is thereby incurred, often amounting to one-half of the liquid product, but of course this loss is largely dependent on the compression. Higher compression leads to a greater yield, but as this is made up of more volatile hydrocarbons, the high yield is, to a large extent, nullified by the greater weathering loss. It is obviously uneconomical to expend energy in compression if a large portion of the condensate is going to be lost. Where the volatile product can be at once mixed with a heavy naphtha the loss is reduced.

According to Singer,<sup>1</sup> the second-stage compression is carried to about 24 atmospheres, the condensation being completed by allowing the highly-compressed cooled gas to expand to atmospheric pressure. The density of this second product is from 0.616 to 0.6365.

Owing to its high vapour pressure this second-stage product is often termed "wild gasoline." It is almost entirely employed for blending with lower-grade refinery naphthas, of density about 0.736-0.740.

Further compression leads to liquefaction of gases, which have such a high vapour pressure at ordinary temperatures that they can only be stored as liquid gas in strong steel cylinders. Such a product is marketed as "liquid gas," or "gasol," and has been successfully employed for motor vehicles, heating and lighting purposes. For general purposes it is marketed in cylinders of about 40 lbs. capacity, which yield about 400 cubic feet of gas.

<sup>1</sup> *Petr.*, ix, 453 (1914).

The "liquid gas" consists chiefly of butane and propane; its density is about 0.6; the calorific value 22,000 Cals. per litre; 1 volume of the liquid gives about 350 volumes of gas of a calorific value of 2400 B.Th.U. per cubic foot. The gas has a very high flame temperature, about 2300° C.

G. Burrell<sup>1</sup> states that in Oklahoma the recoverable gasoline escaping in the gas is estimated as equal to 10 per cent. of the crude oil obtained. The gas is variable in composition and quantity, even from adjacent wells, and is often drawn from the wells under reduced pressure. A yield of 1.5 to 4 gallons per 1000 cubic feet is obtained, the specific gravity ranging from 0.676 to 0.582. The latter is the "wild" product, and loses from 10 to 50 per cent. on exposure. According to J. A. Leo Henderson,<sup>2</sup> in the same State one company produces 35,000 gallons of liquid product daily; a single well has yielded gasoline to the value of over £100 per day. It is further stated that the liquid is piped over a distance of twelve miles.

The refrigerating process by means of liquid ammonia has, according to Henderson,<sup>3</sup> been successfully employed in at least one plant; a Californian company being credited with a production of 1200 gallons per day from 300,000 cubic feet of gas.

Singer<sup>4</sup> says that the product obtained by liquid ammonia refrigeration ranges in density from 0.6855 to 0.651, and consists of about 30 per cent. pentane, 30 per cent. hexane, together with higher hydrocarbons and also butane.

The extraction of gasoline by absorption methods has been dealt with at length by G. A. Burrell, P. M. Biddison, and G. G. Oberfell.<sup>5</sup> Large quantities of poor casing-head gas and other "dry" gas has not been sufficiently rich in condensable products to be economically treated by the compression method; thus in 1914 they estimated that 591,000,000,000 cubic feet of such gas was consumed in the United States. A large proportion of this they regard as suitable for treatment by the absorption method, and would probably yield additional 75,000,000 gallons of gasoline per annum.

Much of the untreated gas has been erroneously regarded as too poor in the hydrocarbons above ethane, but this supposition was frequently based on the old methods of analysis, which quite failed to estimate these higher hydrocarbons. Some "dry" gas treated by these authors yielded three pints of spirits per 1000 cubic feet. The large scale experiments conducted at the Bureau of Mines Experimental Station have undoubtedly shown that the absorption method is well adapted to deal with poor gases, and another promising field for treatment is with the gas which becomes mixed with air when the latter is forced into the sands to increase the flow.

In general the process is almost identical with the oil scrubbing of coke-oven and similar gases for the recovery of benzol, toluol, etc. A heavy oil, such as "mineral-seal oil," is circulated through absorbing towers, where it comes in intimate contact with the gas, thence to stills where the absorbed volatile hydrocarbons are driven off by steam heat, the oil being afterwards cooled before again passing to the absorption plant; a system of heat interchanges is arranged. The oils used have a density of about 0.8485, and boil at over 200° C. (400° F.). Absorption under pressure is very advantageous; in the first place for a given rate of circulation of the oil the rate of absorption is greatly increased, and in the second place the gas has to be delivered into

<sup>1</sup> U.S. Bureau of Mines, *Tech. Paper 17* (1913).

<sup>2</sup> *Journ. Inst. Pet. Techns.*, ii, 213 (1916).

<sup>3</sup> *Loc. cit.*

<sup>4</sup> *Loc. cit.*

<sup>5</sup> U.S. Bureau of Mines, *Bulls*, 120 (1917) and 187 (1919).

the pipe-line under pressure. A gas yielding only 0.7 pint at atmospheric pressure yielded two pints at 110 lbs. pressure. Little or no advantage appears to have resulted by further increase of pressure. At low pressures better absorption is obtained by increasing the oil circulation.

The product obtained by absorption differs considerably from that produced by compression or liquefaction processes. Being driven off from the absorbing oil by heat, it consists only of hydrocarbons condensable by the water circulating in the condensers. It more nearly approaches therefore a "straight" gasoline, but consisting as it does of pentane and hexane chiefly, it is more volatile than the "straight" product. Its weathering loss is, however, much less than that of gasoline produced by compression. The specific gravity is very generally about 0.6667, and may vary between 0.6512 and 0.6763. The vapour pressure is given as 1 lb. at 21° C. (70° F.) to 5 lbs. at 38° C. (100° F.), so that it may be safely transported in tank cars.

The uncondensed gaseous hydrocarbons escaping from the condenser system may be utilised if desired for the production of a high vapour-pressure product by the compression or refrigeration systems.

Instead of oil absorption a heavy naphtha may be employed, and then no further treatment is required. Greatly increased yield of the product may thus be indirectly obtained because of the inherent solvent power of the naphtha for the more volatile hydrocarbons, but there is the disadvantage that at least seven times the volume of naphtha has to be handled for each volume of gasoline obtained.

Tests have been conducted by the Bureau of Mines staff with a large-scale experimental plant on the absorption system, capable of treating 15,000-30,000 cubic feet per hour, and as a result of the experimental work a plant with a capacity of 60,000,000 cubic feet per day constructed. The first technical large-scale absorption plant was erected in 1913 at Hastings, W.Va., and an 80,000,000 cubic feet per day plant has been erected at Catlettsburg, N.Y.

The construction of absorption plants in 1916-17 was rapidly extending, and it was estimated that in the latter year 25 per cent. of the total natural-gas gasoline was produced by absorption plants.

Originally in the mid-continental fields horizontal-type absorbers were erected, but their average efficiency did not exceed 60 per cent., with a maximum of about 75 per cent., and the more efficient vertical or tower type has been largely adopted. These are of two types: those treating the richer gases at low pressures, and those for the comparatively lean gases which require higher pressures.

The low-pressure towers are constructed of light boiler-plate and with a tower 48 feet high and 12 feet diameter, the cross-sectional area is 110 square feet. With a flow velocity of about 30 feet per minute at or below 5 lbs. pressure, the capacity is 2,500,000 cubic feet of 2.5-gallon gas per day.

The high-pressure towers are smaller in volume for a given quantity of gas treated and necessarily of heavier construction, the metal thickness varying from  $\frac{1}{4}$  inch to  $\frac{5}{8}$  inch. Towers varying from 18 feet to 40 feet high, and with diameters of 18 inches to 36 inches have been installed. Increase of pressure permits of smaller cross section and reduction in the quantity of absorption oil. The flow of gas through the towers shows wide variation; it is generally between 20 feet and 75 feet per minute, but owing to the area reductions due to baffling, flow velocities up to 200 feet per minute have been reached in some plants, which is too great for good extraction.

Owing to the high vapour pressures which some of the condensates may

give, and accidents which have arisen from undue pressures in closed vessels, regulations have been introduced governing the handling of these products. The official Classification Committee (U.S.) have issued the following:—“Liquid petroleum gas is a condensation product of the gas issuing from the casing head of petroleum springs. If it has a lower vapour pressure at 100° F. (37·7° C.) than 10 lbs. per square inch, or at 90° F. (32° C.) from 1st November to 1st March, it must be described and transported as ‘gasoline.’ Should the vapour pressure exceed 10 lbs., but not exceed 25 lbs., the product must be termed ‘liquefied gas,’ and be transported in metal drums or casks, or in tank wagons approved by the Master Car Builders’ Association. Products having a vapour pressure above 25 lbs. must be dealt with as ‘compressed liquefied gas,’ (*i.e.* transported in steel cylinders of approved strength).”

Analytical results for some typical blends of natural-gas gasoline with naphthas are given in Table CLXIII.

TABLE CLXIII.—BLENDED CASING-HEAD GASOLINES.<sup>1</sup>

	4.	5.	6.	15.	16.	17.
Original specific gravity, . . .	0·730	0·712	0·690	0·733	0·706	0·687
Iodine number, <sup>2</sup> . . . . .	7·9	4·8	4·2	13·4	3·2	8·4
H <sub>2</sub> SO <sub>4</sub> absorption, . . . . .	1·0	...	...	1·6	...	...
Fractions.						
To 50° C. . . . .	9·8	18·6	30·5	7·9	16·7	30·8
{ volume per cent., . . .						
{ specific gravity, . . .	0·624	0·624	0·624	0·630	0·633	0·630
50-75° C. . . . .	4·8	8·5	12·2	8·9	15·4	18·3
{ volume per cent., . . .						
{ specific gravity, . . .	0·663	0·666	0·666	0·675	0·672	0·669
75-100° C. . . . .	6·9	9·0	12·3	16·4	20·9	15·3
{ volume per cent., . . .						
{ specific gravity, . . .	0·703	0·703	0·703	0·715	0·715	0·712
100-125° C. . . . .	18·2	14·5	11·6	23·4	22·1	13·7
{ volume per cent., . . .						
{ specific gravity, . . .	0·733	0·733	0·733	0·739	0·739	0·739
125-150° C. . . . .	26·8	22·1	12·8	21·9	13·1	10·7
{ volume per cent., . . .						
{ specific gravity, . . .	0·752	0·752	0·752	0·758	0·761	0·758
150-175° C. . . . .	21·3	15·1	10·3	15·0	...	...
{ volume per cent., . . .						
{ specific gravity, . . .	0·767	0·767	0·767	0·776	...	...
175-200° C. . . . .	11·0	10·3	8·1	...	...	...
{ volume per cent., . . .						
{ specific gravity, . . .	0·785	0·785	0·782	...	...	...
Residue, . . . . .	...	...	...	5·9	10·7	10·0
{ volume per cent., . . .						
{ specific gravity, . . .	...	...	...	0·801	0·785	0·785

*Lamp-black from Natural Gas.*—This manufacture in the United States was fully described by Mr. Godfrey L. Cabot, of Boston, U.S.A., in a paper published in the *Journal of the Society of Chemical Industry*, vol. xiii (1894), pp. 128-131.

The following particulars of the industry are taken from a communication by Mr. B. B. Butler to the *Mining and Engineering World* of 28th October 1911:—

“In a bend of the Little Kanawha river, three miles below Grantsville, W. Va., in the heart of an oil- and gas-producing region, is located the largest lamp-black factory in the world. It is owned and worked by Godfrey L.

<sup>1</sup> “Physical and Chemical Properties of Gasolines sold throughout the U.S. in 1915,” W. F. Rittman, W. A. Jacobs, E. W. Dean. *Tech. Paper 163* (1916).

<sup>2</sup> Percentage by weight of iodine absorbed. Hunt’s modification of Hanus method.

Cabot, of Boston, Mass., and is only one of a chain of factories scattered over the state of West Virginia. Other plants owned by Mr. Cabot are at Creston, 16 miles below Grantsville, at Spencer, at Bristol, and at Cabot, Pa. The plant at Creston is being enlarged; it was started in 1910. In the plant at Grantsville the open-ring method is used, though the waste is greater in the use of this method than any other.

"The 'rings' in which the black is produced are 60 feet in circumference, and near the top of the ring is a flat, smooth iron plate entirely covering the ring. The black is made by impinging the burning natural-gas jet upon the surface of the plate, which is kept constantly revolving. Against the plate is arranged an automatic scraper which removes the black produced. By means of screw conveyors the black is conveyed from the scraper to a large bin, where it is ground, sifted, and bolted, and all foreign matter eliminated. The better part is elevated to a packer bin, while the waste is carried off. From the packing bin it is run into bags containing  $12\frac{1}{2}$  lbs. each and into barrels containing 100 lbs. of black. The capacity of this plant is nearly 8000 lbs. daily. Each ring contains 1265 burners, or tips. In all, 142,945 tips are employed, consuming 9,143,560 cubic feet of natural gas daily. At least one-fourth of the gas burned, and probably one-third, is wasted, in the form of lamp-black carried through the vents in the 'rings' by the heat. A dense cloud of black smoke arises from the plant and hovers over it."

### PETROLEUM AS FUEL.<sup>1</sup>

Crude petroleum is commonly employed as fuel for steam-raising in the various oil-fields, but the usual presence in the oil as it comes from the wells of the more volatile hydrocarbons introduces an element of risk in storage and handling, and for general industrial purposes the petroleum is deprived of these hydrocarbons by distillation, the liquid fuel thus being obtained of a specified minimum flash-point.

The characters which a fuel oil should possess are high calorific value, fluidity at moderately low temperatures, freedom from solid matter which may choke the jets of atomisers or cause trouble through abrasion, and a satisfactorily high flash-point. Some authorities lay stress on a low sulphur content, and a maximum figure is quoted in many specifications, but the harm resulting from sulphur has probably been overestimated.

The British Admiralty Fuel Oil Specification states that the oil fuel supplied shall consist of liquid hydrocarbons, and may be either (a) shale oil; or (b) petroleum as may be required; or (c) a distillate or a residual product of petroleum.

The flash-point shall not be lower than  $175^{\circ}$  F., close test, Abel or Pensky-Marten.

In the case of oils of exceptionally low viscosity, such as distillates from shale, the flash-point must be not less than  $200^{\circ}$  F.

Sulphur shall not exceed 0.75 per cent.

<sup>1</sup> The use of liquid fuel has been described by Aydon, *Proc. Inst. Civ. Engineers*, lii, 177 (1878); Urquhart, *Proc. Inst. Mech. Engineers* (1884, 1888, and 1889); Mills and Rowan, *Fuel and its Applications*, London (1889); Veitch, *Das Erdöl* (1892); Robinson, *Journ. Soc. Arts*, April 29 (1891), and Cantor Lectures (1892); and the author (*Journ. Soc. Chem. Ind.*, iv, 70, and Cantor Lectures, 1886). More recent works on the subjects are: *Liquid Fuel and its Combustion*, by Wm. H. Booth (1903), *Liquid and Gaseous Fuels*, by Vivian B. Lewes (1907), and *Oil Fuel*, by Sydney H. North, 2nd ed., revised by Edward Butler (1911); *Fuels: Solid, Liquid, and Gaseous*, by J. S. S. Brame (1917); J. S. S. Brame, *Journ. Inst. Pet. Techs.*, iii, 194 (1917), on "Liquid Fuel and its Combustion."



The oil fuel supplied shall be as free as possible from acid, and in any case the quantity of acid must not exceed 0.05 per cent. calculated as oleic acid when tested by shaking up the oil with distilled water, and determining by titration with decinormal alkali the amount of acid extracted by the water, methyl orange being used as indicator.

The quantity of water delivered with the oil shall not exceed 0.5 per cent.

The viscosity of the oil supplied shall not exceed 1000 seconds for an outflow of 50 cubic centimetres at a temperature of 32° F., as determined by Sir Boverton Redwood's Standard Viscometer (Admiralty type for testing oil fuel).

The oil supplied shall be free from earthy, carbonaceous, or fibrous matter, or other impurities which are likely to choke the burners.

In the British Mercantile Marine the minimum flash-point is 150° F.

The United States Specifications for Navy fuel oil, gas oil, and bunker oil state that (a) fuel oil shall be a hydrocarbon oil free from grit, acid, and fibrous or other foreign matter likely to clog or injure the burners or valves. If required by the Navy Department, it shall be strained by being drawn through filters of wire gauze having 16 meshes to the inch. The clearance through the strainer shall be at least twice the area of the suction pipe and strainers shall be in duplicate.

(b) The unit of quantity to be the barrel of 42 gallons of 231 cubic inches at a standard temperature of 60° F. For every decrease or increase of temperature of 10° F. (or proportion thereof) from the standard, 0.4 of 1 per cent. (or prorated percentage) shall be added or deducted from the measured or gauged quantity for correction.

(c) The flash-point shall not be lower than 150° F. as a minimum (Abel or Pensky-Marten's closed cup), or 175° F. Tagliabue open cup. In case of oils having a viscosity greater than 8 Engler at 150° F. the flash-point (closed cup) shall not be below the temperature at which the oil has a viscosity of 8 Engler.

(d) Viscosity shall not be greater than 40 Engler at 70° F.

If the Engler viscometer is not available, the Saybolt standard universal viscometer may be used. Equivalent viscosities:—

8 Engler,	.	.	.	.	.	300 seconds Saybolt.
40 "	.	.	.	.	.	1500 " "

(e) Water and sediment not over 1 per cent. If in excess of 1 per cent., the excess to be subtracted from the volume; or the oil may be rejected. Water and sediment will be taken by the distillation method. When oil in small lots is consigned to Naval vessels or to Navy Yards the centrifuge test will be used in order to obviate delay. In this test 30 c.c. of oil and an equal quantity of best commercial benzol, 30 per cent. white, will be used, and the mixture heated to 100° F.

(f) Sulphur not over 1.5 per cent.

For many years Russia was the only country producing and consuming liquid fuel on a scale of commercial magnitude, the crude petroleum from the prolific oil-fields of Baku yielding a large proportion of a suitable product, but for some time past there has been in the United States a rapid growth in the general employment of liquid fuel, large supplies being obtained in California, Texas, and elsewhere. The Kutei district of Borneo has also become an important factor in the industry, the petroleum found there yielding an excellent fuel oil and being apparently obtainable in very large quantities. Among

other present and prospective sources of supply to which the now general recognition of the advantages of liquid fuel, especially for marine purposes, has caused attention to be directed, are those of Burma, Persia, Egypt, Trinidad, Mexico, Galicia, and Rumania, and there can be no doubt that the efforts now being made to develop fresh sources of supply will result in a very considerable increase in the quantity at present available. It would, however, be misleading to suggest that there is any prospect of a general substitution of oil for coal as fuel in steam-raising and for other purposes. The author pointed out in giving evidence before the Royal Commission on Coal Supplies in 1903, that if the then aggregate output of petroleum in the world were doubled, and the whole of the surplus thus created were used as fuel, this surplus would, taking into account the relative thermal efficiencies, only be equivalent to about 5 per cent. of the world's output of coal.

It has also to be taken into account that with the development of most oil-fields there is a progressive decrease in the proportion of fuel oil yielded by the crude petroleum, the oil obtained at greater depth usually containing a larger proportion of the more volatile hydrocarbons. Lastly, the exhaustion of the older oil-fields, which is proceeding *pari passu* with the opening up of new fields, must not be lost sight of in forming an estimate of the extent to which the world's supplies may be augmented. In this connection, attention should be drawn to a report in which Dr. David T. Day, the expert of the United States Geological Survey, in charge of petroleum investigation, gave the data on which he arrived at the somewhat startling conclusion that at the rate of increase of the output of petroleum the known oil-fields of that country would, on the basis of the estimated minimum quantity of oil obtainable, be exhausted by the year 1935, whilst if the output at that time were only maintained, the supply would on the same basis only last for ninety years. In these circumstances it is fortunate that, through the success which has attended the introduction of the Diesel engine, to which reference will be made subsequently, every attention is now being given to the extended use of the internal-combustion engine, for with the Diesel type of engine it is possible to obtain about three times as much power from a given quantity of oil as is usually yielded when the oil is used for steam-raising in conjunction with the best types of steam-engine, though, as is hereafter pointed out, modern improvements in the raising and use of steam may be held to necessitate a revision of this comparison.

In their final report, dated 7th January 1905, the Commissioners express themselves on the subject of the substitution of oil for coal in the following terms:—

“There has been much disposition in recent years to speak of oil fuel as if it were a serious competitor of coal, and a real substitute for it. The facts before us do not bear out that view. Dr. Boverton Redwood in his evidence has given us a valuable account of the present and prospective sources of supply of petroleum and its allied products, and while he thought there was ample scope for energy and capital in searching for and opening up fresh sources of supply, he expressed himself very strongly against the possibility of any largely extended use of petroleum as a substitute for coal. He pointed out that the world's production of coal in 1901 was 777 million tons, and that in the same year the world's production of petroleum was 22 million tons, or only 2·8 per cent. of the weight of the coal.

“The conclusion we have arrived at as regards the use of oil fuel in this country is that which is expressed by Dr. Boverton Redwood in answer to Question 13,559, when he said: ‘I think there will be certain selected appli-

cations of liquid fuel where the advantages of employing such a fuel are especially obvious ; but for anything like general employment, I cannot see where we are to look for adequate supplies.”

For Naval purposes the many advantages liquid fuel offers make its use almost indispensable ; here cost cannot be allowed to outweigh the advantages gained by its adoption. As is well known, it has been widely adopted by all the great Powers, and the large oil-fired turbine-propelled battleships and battle-cruisers of the British Navy fully proved the capabilities of oil, as was the case also with the smaller units, light cruisers, destroyers and even submarines.

The author has on many occasions pointed out the advantages presented by the use of liquid fuel. On shipboard these are especially marked. Not only can a supply of liquid fuel be taken on board far more easily, more quickly, and at less cost than a supply of solid fuel, and in the case of a passenger steamer without occasioning the discomfort attendant upon “coaling,” but it occupies, for an equal value in steam-raising, only about half the space ; the vessel can therefore either make a far longer voyage without the necessity arising for replenishing the bunkers, or a certain amount of space, which, if coal were used, would be occupied by the fuel, can be devoted to cargo. The labour of stoking and coal-trimming, which is most exhausting in a tropical climate, is completely done away with, and there are no ashes and clinkers to be removed. The combustion is smokeless under natural draught—and may be made so under forced draught—a point of no small importance in the belligerent marine ; no soot or dust is deposited in the boiler-tubes ; the fire can be instantly extinguished or as quickly relighted, and is under complete control, waste of steam at the safety-valve on the one hand, or a short supply on the other, being easily avoided. If the flame should be extinguished in stormy weather, there is no delay in kindling it again, and the risk of scalding is diminished. The oil may be carried in bunkers where coal could not be put, and these may be filled with water as the oil is used, so that the trim of the vessel need not be altered during the voyage, and, if suitable oil is used, there is no danger of explosion or fire, such as attaches to the carriage of coal. The chief practical difficulty formerly encountered in the use of liquid fuel on shipboard was the provision of a supply of steam for atomising the oil. The steam used in the engines is, of course, condensed, and the water returned to the boilers ; but in respect of that which is employed for spraying the oil, an equivalent amount of fresh water must be replaced in the boilers, and to obtain this it is usually necessary to have an independent distilling apparatus. This objection obviously does not attach to those burners in which the atomising is effected mechanically, the type now almost universally employed.

During recent years oil fuel has firmly established its position as the best fuel for steam-raising in the Mercantile Marine and Naval Service, but although it was found fairly easy to obtain smokeless combustion in the furnaces of cargo boats, where there was plenty of grate space to allow completion of the combustion, the problem presented much difficulty in ships where the restricted space available for the boilers necessitated a much larger consumption of fuel per foot of combustion space, and under these conditions most of the burners which had given good results when used to inject comparatively small quantities of the fuel, gave dense black smoke when the consumption was largely increased.

This arose partly from the fact that the furnaces were designed to burn steam coal, about 75 per cent. of which is consumed upon the furnace bars, yielding chiefly carbon monoxide, which needs only a comparatively small

proportion of air to complete its combustion in the furnace and combustion-chamber, and partly from the fact that when a substance like oil is injected into the furnace, the impetus imparted by the injector is aided by the draught of the funnel, with the result that the oil vapour is hurried through the furnace, combustion-chamber, and tubes too fast to allow anything like complete combustion to take place, and dense smoke is produced.

It was also found that steam injection added to the trouble when the area was small, and the fact that 0.2 lb. of steam per I.H.P. is used in atomising and injecting, threw an extra strain upon the boilers.

Such burners as most of the modern "pressure" type not only possess the advantage of operating without the use of steam, but as they cause the stream of injected atomised oil to follow a spiral, instead of a direct, course through the furnace, the length of travel of the oil spray is increased and more time is given for the chemical action essential to the attainment of smokeless combustion.

It will be apparent that many of the advantages which have been pointed out, attach to the substitution of liquid fuel for coal on locomotives and in stationary boilers. At electric generating-stations in large cities, where the delivery and storage of coal and the removal of ashes are not easy, and where in consequence of fog there may be a sudden and unexpected demand for steam, it would appear to be exceptionally desirable to employ liquid fuel, and there can be but little doubt that, if adequate supplies of suitable oil become available for the purpose, this description of heating agent will be more largely employed.

For industrial operations oil fuel has also been extensively adopted. Here, as a general rule, low-pressure air-spraying is the most satisfactory system and the least costly. For metal melting, and reheating of billets for forgings and stampings; for rivet heating and heat treatment of tool steels, many efficient patterns of oil-fired furnaces are constructed. An increased number of heats is possible in the working day and loss of metal in melting operations is reduced. For glass-melting furnaces and even cement furnaces, where oil is cheap, it has also been successfully used.

In a method patented in 1883 (No. 1157) by Mr. J. Riley, for application of oil fuel to regenerative furnaces, the oil is supplied from a tank through a stop-cock, to a series of nozzles which are automatically turned to project the oil into either side of the furnace according to which of the regenerators is in action. A method of burning oil in open trays for furnaces in which iron and steel were melted in an open hearth or in crucibles, was introduced by Nordenfelt.

In the "Eames" process, introduced for the purpose of melting down scrap iron and rolling the product into boiler-plates, the oil ran downwards over a series of shelves projecting alternately from opposite sides of a cast-iron generator, and in passing from shelf to shelf was gasified by a slow current of highly superheated steam. The mixture of vapour and steam passed into a "mixing chamber," occupying the position of the former fire-space, where it met the air-blast, and was driven through an opening in the furnace bridge-wall and over the furnace-bed.

According to a communication from Mr. A. von der Ropp to the California Miners' Association, crude petroleum is used in the works of the Selby Smelter in four roasting-furnaces with eleven burners, one matting-furnace with three burners, one copper-furnace with one burner, fourteen lead-furnaces with fourteen burners, thirteen zinc-retorts with thirteen burners, three cupel-furnaces with three burners, one antimony-furnace with one burner, and one furnace for smelting fine silver with one burner. For all these purposes the

oil fuel is found to give better results than the coal previously used, and there is an accompanying saving in the cost of fuel of 40 to 60 per cent. Mr. Ropp gives the following reason for not employing oil in the blast-furnaces: "Solid carbon plays a very important rôle, especially in the upper level of the blast furnace shaft. Its function, especially with the fine ores, is largely to limber up the charge, and allow the flow of gas to penetrate the charge evenly; besides, incandescent carbon has certain functions to perform in the blast-furnace, which are of a chemical nature, and which need not be discussed. If coke or charcoal should be entirely replaced by oil in the blast-furnace, the blast-furnace charge would very likely become too dense to allow the combustion gases to escape freely."

In an article on the economic position of the oil-fuel question, published in *The Engineer* of 29th December 1911, Messrs. Sydney H. North and G. Maitland Edwards state that in the rolling mills of the Southern Pacific Railway works at Sacramento 40 gallons of crude petroleum are used to heat 2000 lbs. of scrap metal or pile, in place of 500 lbs. of bituminous coal formerly employed in a reverberatory furnace for the same purpose; that the output of the oil-fired furnace is 20 per cent. higher than that of the coal furnace; and that there have been 50 per cent. less car-axles condemned since the adoption of oil fuel.

The earliest application of oil fuel for general heating purposes naturally was at the refineries where large quantities of residual heavy oils were available, and its application to petroleum distillation and steam-raising at the refineries and on local railways followed.

In Russia, where the petroleum industry has long since become mainly a great fuel industry, the development in the use of liquid fuel on the railways was mainly due to the initiative of Mr. Thomas Urquhart, who whilst locomotive superintendent on the Grazi-Tsaritsin railway demonstrated the merits of this fuel. Liquid fuel is not only employed as the source of heat in a large number of industrial establishments throughout Southern Russia, but is also used on the locomotives of the railway systems of that district and on the steamships on the Caspian Sea. It is also similarly employed in the Baku and Grozni oil-fields and refineries. Fig. 322 shows the details of an arrangement for burning liquid fuel, as applied to a steam-boiler for use in oil-fields, including the method of construction of the brick baffle in the combustion-chamber.

In a paper read before the Institution of Mechanical Engineers by Mr. R. Godfrey Aston, the results of the working of oil-burning locomotives of the Baldwin consolidated type on the Tehuantepec National Railway of Mexico were given as follows:—

TABLE CLXIV.—MONTHLY AVERAGES.

Year.	Cost of Oil per Barrel, Shillings.	Cost of Fuel, Pence per Mile.	Distance run per Barrel, Miles.
1907	5·17	10·99	5·928
1908	5·91	10·48	6·855
1909	5·01	9·73	6·209
1910	4·71	9·66	5·483
1911*	3·98	8·58	5·520

\* Eight months.

Based on tests which have been made, the company reckoned that  $3\frac{1}{2}$  barrels, or 147 United States gallons, of oil are equal to 1 short ton (2200 lbs.) of coal.

The fuel used by this railway company was purchased from the Texas Company of Port Arthur, Texas. The railway company stipulated in its contracts

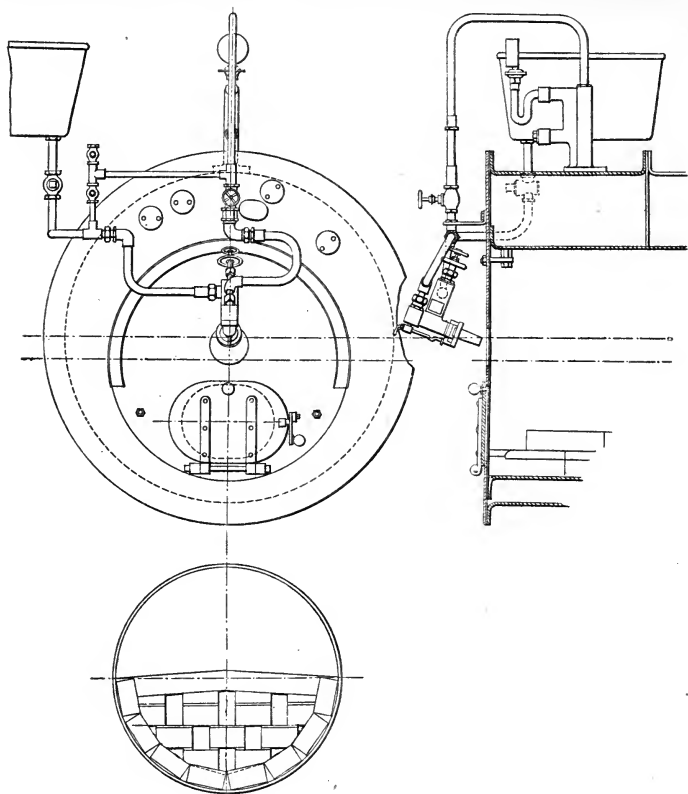

FIG. 322.—LIQUID FUEL FIRING.

with the Texas Company that the flash-point (closed) should not be under  $110^{\circ}$  F. The calorific value in British thermal units varied from 17,000 to 20,000.

In the Galician oil-fields, crude oil has largely replaced coal and wood for steam-raising purposes, and petroleum residuum and "blau" oil are used as fuel in several refineries and factories in Galicia. In Rumania a mixture of benzine and residuum was similarly employed. On the Arlberg railway in the Tyrol locomotives are being driven with liquid fuel.

In this country the principal exponent of the advantages of liquid fuel for

railway work has been Mr. James Holden, locomotive superintendent of the Great Eastern Railway, who commenced the use of fuel oil on this line in 1886, with a form of burner invented by him which is elsewhere described in this section.

In practice it has been found that one ton of oil is equal in thermal efficiency to about one ton and three-quarters of steam coal, and, although there is no doubt still room for improvement in the burning of liquid fuel, it does not seem reasonable to conclude that the steam-raising power of oil will ever much if at all exceed twice that of good steam coal. At present it may be taken that whereas 1 lb. of good steam coal will evaporate 9 lbs. of water, 1 lb. of liquid fuel will, under the best conditions, evaporate 16 lbs., and in locomotive practice from 13 to 14 lbs. In his evidence before the Coal Commission, Mr. Holden stated that, weight for weight, the liquid fuel had, according to his experience, approximately twice the evaporative efficiency of coal.

An elaborate investigation of the relative evaporative efficiencies of coal and liquid fuel under forced and natural draught has been conducted by the United States "Liquid Fuel" Board, and the exhaustive report issued in 1904 constitutes an important contribution to the literature of the subject. The coal used was Pocahontas and New River, the calorific value of which (in B.Th.U.) ranged from 14,067 to 14,992. The oil employed was chiefly Texas crude petroleum, from which the sulphur and some of the more volatile constituents had been removed, but Californian oil was also used in some of the tests. The calorific value of the Texas oil, calculated on the analysis of the United States chemist by Dulong's formula, was 19,481 B.Th.U. Seventeen distinct forms of liquid-fuel burners, some of which are described in the following pages, were tried, and it was found that they were "undoubtedly about equal in efficiency, and that there was but little difference in the value of the oil from the two localities as measured from the standpoint of weight." On the other hand, it was demonstrated "that the character of the installation was all-important."

In regard to the similarity of conditions attending the oil-fuel installations for locomotive and torpedo-boat work, it was found that the following advantages were practically obtainable in both cases:—

- (a) Economy of space reserved for carrying fuel.
- (b) Ease in filling tanks.
- (c) Rapidity of time in meeting a varying load on boiler.
- (d) Ability to force boiler to extreme duty in case of emergency.
- (e) Absence of smoke under light normal working conditions.
- (f) Short height of stack.
- (g) Superior *personnel* available for the operation of the burners.
- (h) Ability to secure and maintain higher speed with oil fuel than with coal.

The report points out that for marine purposes it is desirable that burners should be installed capable of effecting vaporisation of oil without the aid of any intermediary of steam or compressed air, since the direct use of steam entails a corresponding loss of fresh water, whilst the introduction of air-compressors encroaches upon the weight and space allowed for installation of machinery, and requires considerable attention in the nature of upkeep and repairs. Mechanical spraying of the oil can be effected by forcing the oil under considerable pressure from a properly formed orifice, or by passing it through a rapidly-revolving burner-head whereby it is whirled or flung outwards. Of the mechanical burners it is stated that very few have achieved success, but with the Körting burner a test was carried out which showed an

evaporation of over 16 lbs. of water from and at 212° F. per pound of oil fuel consumed. The Board reported that "the impossibility of successfully operating burners designed on the principle of superheating the oil to a point bordering on gasification had been both theoretically and practically demonstrated." The importance of making provision for the removal from the oil of mechanically suspended earthy matter and water, and in some circumstances for the heating of the oil to facilitate its flow to the burner, are insisted upon, and two forms of oil-strainers are described. The very important question of furnace-construction in connection with the substitution of liquid fuel for coal is fully discussed, and the difficulty of securing smokeless combustion in the extremely limited furnace-space available in marine boilers, especially those of battleships, is emphasised; in fact, the Board report that in the tests made under strong forced-draught conditions dense smoke was freely emitted. On the subject of the effect of steam in modifying the character of the combustion of the oil, the Board express themselves as follows: "While it may be true that the presence of steam may change the character and sequence of the chemical reaction, and result in the production of a higher temperature at some part of the flame, such an advantage will be offset by lower temperatures elsewhere between the grate and the base of the stack. All steam that enters the furnace will, if combustion is complete, pass up the stack as steam, also carrying with it a certain quantity of waste heat. The amount of this waste heat will depend upon the amount of steam, and its temperature at entrance of the furnace. The quantity of available heat, measured in thermal units, is undoubtedly diminished by the introduction of steam." The Board report that the relative evaporative efficiency of oil and coal as a fuel, as determined by the extended series of comparative experiments, is practically in the proportion of 15 to 10, but that the actual superiority of oil will be considerably greater; for in the coal experiments unusual skill was exercised in the management of the fires, lump coal of superior quality was used, and as the tests were of comparatively short duration, there was much less loss in cleaning fires than would occur in practice; whilst, on the other hand, the oil experiments were carried out under conditions that more closely approximated to those that could be secured on board a sea-going vessel. The actual evaporative efficiency of a pound of oil as compared with a pound of coal is therefore reported to be in the ratio of 17 to 10, and the Board state that these figures may be regarded as substantially correct. In noting the comparative efficiency, for naval purposes, of oil and coal, the Board point out that there must also be taken into consideration the fact that a ton of oil can be stowed in somewhat less space than a ton of bituminous coal; also, that in the carrying of oil the compartments can be more completely filled. The relative efficiency of oil and good steaming coal, from the naval standpoint of fuel-supply in warships, may thus, they say, be regarded as in the ratio of 18 to 10. In relation to the evaporative efficiency secured, the Board point out that the experimental boiler used was designed for actual navy conditions, and that the limitations prescribed by the Department as to height, weight, and floor-space were of a severe nature. There was not only considerable radiation from the boiler, but the proportion of heating-to grate-surface was not as large as in the land boilers. Taking these facts into consideration, the efficiency results are regarded as exceedingly satisfactory. Until greater space is obtained for the installation of marine boilers, it will not, in the opinion of the Board, be possible to secure, in actual naval practice, an evaporation from and at 212° F. of over 14 lbs. of water per pound of oil fuel; but it is considered that increased efficiency may be secured by heating the air requisite for combustion, by the adoption of the Howden or some



similar system, whereby the heat of the escaping gases is utilised for raising the temperature of the entering air requisite for combustion.

*Types of Burners.*—For generating steam in stationary boilers, Mr. Ludwig Nobel suggested the employment of a very simple system, the arrangement consisting of a series of shallow troughs arranged in superimposed series at the door of the furnace in such a manner that the liquid fuel supplied to the top receptacle overflowed into the one beneath it, and thus travelled downwards through the whole series. The troughs were separated sufficiently to admit of the entrance of a current of air which swept over the surface of the burning oil, and carried the flames into the furnace. It was found that 1 lb. of ostatki, when thus burned, evaporated 14.5 lbs. of water, while it only evaporated 12 lbs. when consumed in a spray burner, and that coal evaporated only 7 to 8 lbs. of water per pound of fuel, in the same boiler.

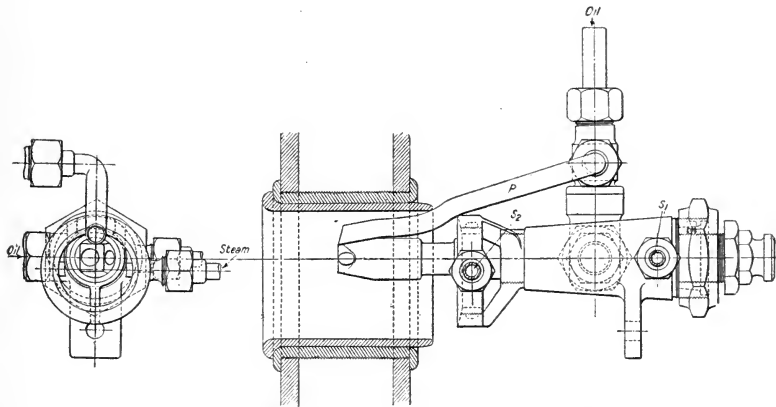

FIG. 323.—GENERAL VERTICAL VIEW OF HOLDEN BURNER.

It is, however, more common and convenient to burn the oil by means of an injector, the oil being thus driven by a jet of steam, or in some cases, of compressed air, into the combustion-chamber in the form of spray, together with the amount of air necessary for its combustion, or atomised by being forced at high pressure through a suitably constructed jet. Such a system was patented as early as 1865-7 by Aydon, Wise, and Field. In 1868, Donald of Glasgow patented a similar arrangement.

Figs. 323 to 325 represent the method of burning liquid fuel introduced by Mr. James Holden, and at one time employed on many locomotives on the Great Eastern and other railways at home and abroad. Fig. 323 gives a vertical view of the injector, showing a supplementary oil-feed down the sloping pipe, P. Fig. 324 shows a sectional plan of the injector. The main oil-feed is through the side pipe, the oil passing to the annular passage, A B. The main steam enters through  $S^1$  into the annular passage, CD, and passes to the nozzle through the space between the central air-tube and the oil space leading from A B to the nozzle. The steam thus draws in the oil, together with a certain amount of air, and breaks up the oil into a spray. The oil is

further atomised by an independent steam supply passing through  $S^2$  to a hollow steam ring, R, which is pierced with holes in such a manner that the

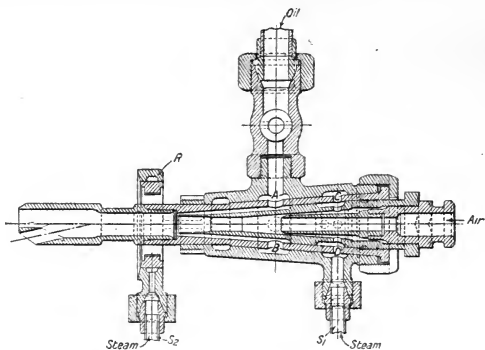

FIG. 324.—SECTIONAL PLAN OF HOLDEN BURNER.

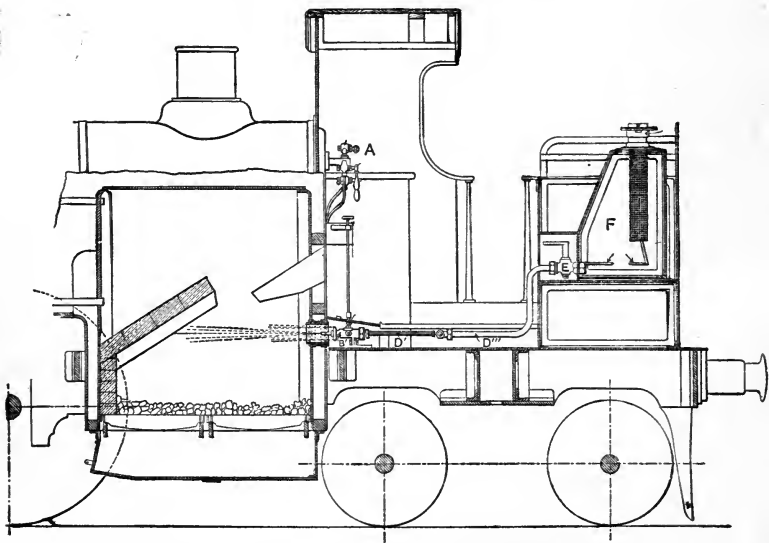

FIG. 325.—OIL-FIRED LOCOMOTIVE (HOLDEN SYSTEM).

issuing jets of steam converge towards the nozzle, and strike across the current of partly-sprayed oil. This auxiliary steam supply also serves the important purpose of breaking up the main jet, so that the flame is well diffused in the fire-box, steam from the dome being used to ensure it being as dry as possible

in all cases. In a later form of burner fitted to some locomotives, the main steam jet is so arranged as to form an air-ejector, and the air-tube is connected by a flexible hose with the vacuum brake. The oil flows from a tank, F (fig. 325), through a pipe, D''D', into the injector, B, and the steam is controlled by valves on fitting, A. A steam-coil is employed to keep the oil fluid in cold weather. The jet plays upon an inclined firebrick bridge, and the bars of the grate are covered with a thin layer of coal and cinders mixed with broken firebrick. As the coal slowly burns away, it is renewed, so that incandescence is always maintained to ensure complete volatilisation and combustion of the oil.

A recent type of Holden burner of special design for general steam production and industrial heating is shown in fig. 326. The oil is fed by gravity into the outer annular space, and the atomising steam into the next inner space, air being drawn at the same time into the centre. The mixture passes at high velocity to the larger chamber at the front of the burner, and jets issue from holes bored at suitable angles in the front plate. The angles of the holes

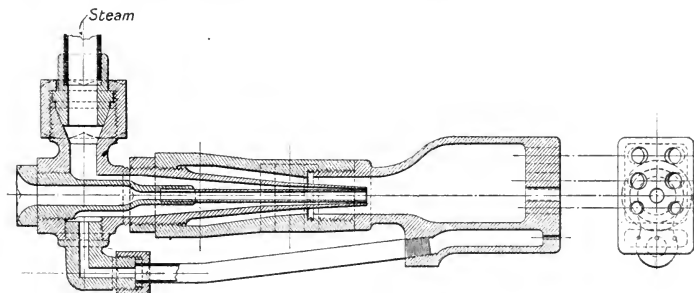

FIG. 326.—HOLDEN BURNER.

are adjusted so that the jets impinge on each other, a further breaking up of the spray being accomplished by steam led along the pipe beneath the burner, this steam escaping through two holes placed at a suitable angle to ensure the two jets impinging on the atomised oil jets.

Figs. 327 to 330 exhibit the construction of the appliances adopted by Urquhart for burning *ostatki* on the locomotives on the Grazi-Tsaritsin Railway in south-east Russia. The figures show the radiating chamber of firebrick employed for heating the boiler, and the means adopted for heating the air-supply which is drawn in by the exhaust-blast of the engine. A sight-hole, H, is provided in the fire-door, and a pointer, D, is arranged on the screw which regulates the oil-supply cock. A pipe, S, supplies steam to a coil in cold weather, in order to prevent solidification of the oil fuel. The oil-supply pipe is shown at P. Mr. Urquhart states that "with a locomotive in first-class order and in the hands of a skilful driver, 50 tons of petroleum refuse is equal to 100 tons of first-class coal."

The Rusden-Eeles burner, shown in fig. 331, is of the steam atomising type, and although superseded in marine work by burners in which steam is not used, is of considerable historical interest as being one of the first liquid-fuel burners largely employed on ships. The first vessel fitted with this burner was the petroleum tank-ship *Baku Standard*, which crossed the Atlantic burning

oil in 1894, and since that date over 1500 of these burners have been installed in over ninety steamers.

Another burner of the same type, deserving mention, is known as the Orde

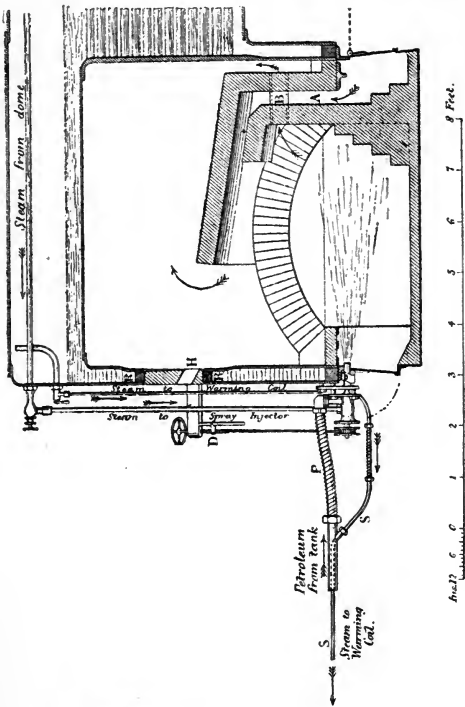
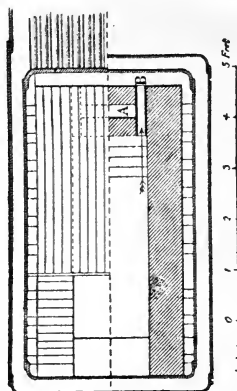

FIG. 328.



Locomotive Combustion Chambers.

FIG. 330.

URQUHART'S OSTATKI BURNER.

FIG. 329.

burner. The construction is shown in fig. 332. With this burner, which was invented by Mr. Edwin L. Orde, of Sir W. G. Armstrong, Whitworth and Co., Ltd., an evaporation of 13.3 lbs. of water per pound of oil, from and at 212° F., was obtained with a water-tube boiler, without the production of smoke.

One form of the Oil City Boiler Works' burner employed in the tests made by the U.S. Naval "Liquid Fuel" Board is shown in fig. 333. Of the latest form of this burner the Board reports that it is "a development of possibly one or two hundred types that have been used in the oil regions of Pennsylvania and Ohio during the past thirty-five years. While the present device is not a

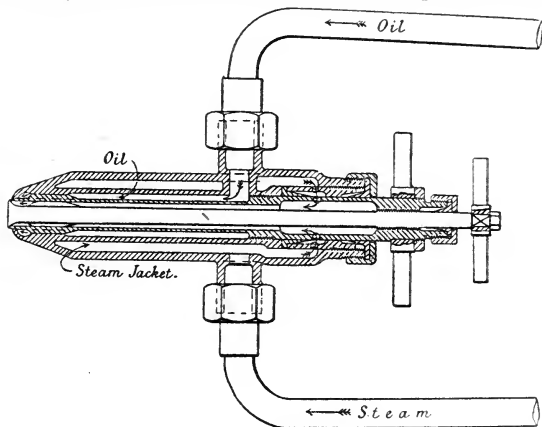

FIG. 331.—RUSDEN-EELES BURNER.

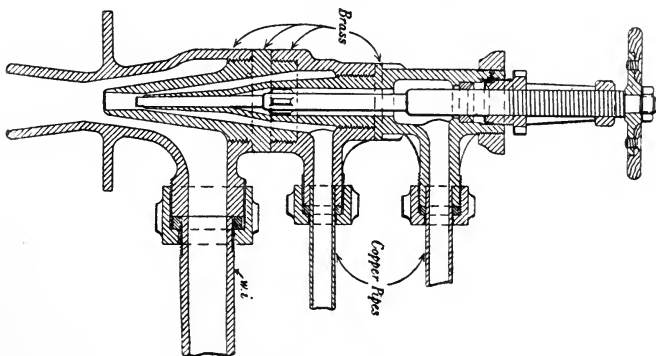

FIG. 332.—ORDE BURNER.

patented article, it is the outcome of extended experiments and experience, and the results secured from its use, whether regarded from the standpoint of efficiency or of capacity, will compare favourably with any type that was used during the trials." Another burner with which excellent results were obtained is the W. N. Best burner (fig. 334). "The burner is of the slot design, the atomising slot being above the oil-supply passage. This arrangement is supposed to prevent the accumulation of carbon in the oil slot. By thus

siphoning in a uniform manner the oil from its supply channel, and arranging for a high velocity of the atomising agent, the separation of the particles of the liquid fuel can be satisfactorily effected, and thus complete combustion secured. Means are also provided whereby the atomising channel can be easily cleared of any scale or other foreign substance without removing the burner from its fixed position." The Board remarks that the tests made show that the system is probably one of the best that could be applied to a boiler for either natural or forced draught conditions. "The Board desires to emphasise the fact, however, that the general installation as much as the special form of the burner was responsible for the satisfactory results secured."

In Curle's burner, known as the "Carbogen" burner, patented in 1905,

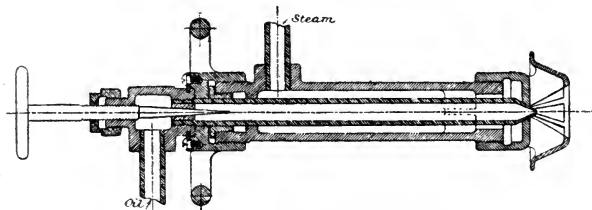

FIG. 333.—OIL CITY BOILER WORKS' BURNER.

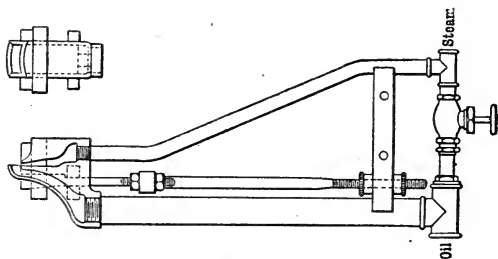

FIG. 334.—W. N. BEST BURNER.

there are three concentric nozzles, as shown in fig. 335, the innermost for the supply of air, the intermediate one for fuel, and the outer one for air. In respect of this burner it is claimed that the effect of the air jets on the oil is to cause a very complete atomisation, as the central air jet causes the oil to diverge in a spray which is met by the converging annular jet of air from the outer casing, which results in the spray being further broken up. This burner has been found very suitable for the application of liquid fuel to glass-melting and furnace work for general metallurgical purposes, as a temperature of 3500° F. can be steadily maintained without any emission of smoke. The Morgan Crucible Company have designed a tilting crucible furnace for use with this burner.

The air-jet burner of Kermode's Liquid Fuel System is shown in fig. 336. The oil enters at the branch, A, after which its flow is regulated by the conical valve shown. The air, after being heated by being passed through a suitable apparatus placed in the hot gases from the boiler, enters the branches B and C.

The air, entering through C, meets the oil as it passes the oil-control valve, which is operated by the wheel, E, and the oil and air travel on together, the former being rapidly vaporised in its passage. In order to assist this process, there is a helix, K, placed in the contact tube, which effects a complete admixture of the air and vapour. The supply of air can be regulated at two points by means of the wheels, pinions, and racks. One of these pinions (marked L) moves the internal tube over the oil-delivering nozzle, F, and so regulates the air which enters there. The second pinion, M, operates the outer tube and

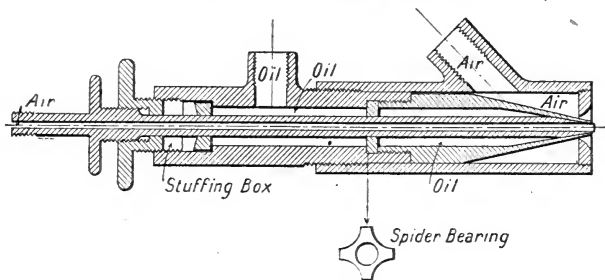

FIG. 335.—CURLE'S BURNER ("CARBOGEN").

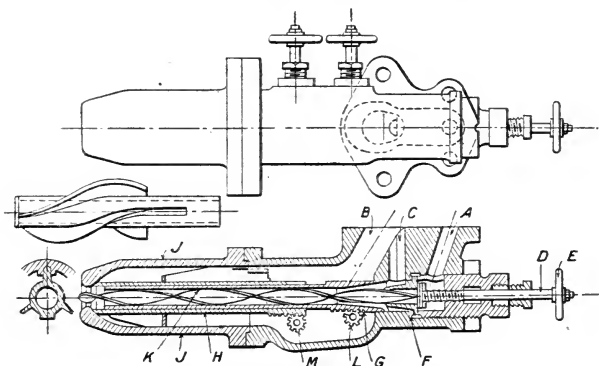

FIG. 336.—KERMODE HOT-AIR BURNER.

varies the amount of air escaping round the mixed jet at the end of the twisted spindle, K. By this arrangement the combustion is effectively controlled and is very complete, for the oil trickling from the nozzle is carried forward by the current of air which surrounds the nozzle. At the point where combustion is about to commence a further supply of compressed air is given, and a third supply is added by the draught which comes through the fire-bars or, in special cases, which passes through a hollow furnace-front, between the inner and outer plates, and escapes through a coned opening round the burner. With two of these burners fitted to a boiler of the Babcock and Wilcox type at the Toulas Brass Rolling and Cartridge Works in Petrograd an evaporation from and

at 212° F. of 15.91 lbs. of water per pound of fuel was obtained, although the oil used was stated to be not of a very high calorific value. According to particulars furnished by Mr. J. J. Kermode, the air is used at a pressure of 3 lbs. per square inch, and the air-compressor consumes 2 per cent. of the steam raised. The oil fuel may vary in consistency from that of coal-tar to that of light petroleum, and oil with as much as 20 per cent. of water in suspension may be used with this burner. From 73 to 84 per cent. of the calorific value of the fuel may be thus rendered effective, and the burner may be worked either without or with forced or induced draught.

In another form of this burner (fig. 337) steam is used as the atomising agent, 3 per cent. of the steam raised being required for this purpose, and from 68 to 74 per cent. of the calorific value is given as useful work.

The Kermode hot-air burner is claimed to be specially applicable to forging and welding furnaces, core drying, ore-reducing furnaces, bakeries, gas retorts, brewing and distilling plants, annealing and tempering furnaces, glass furnaces, rivet heating, brass melting, cloth-singeing machines, refuse destructors,

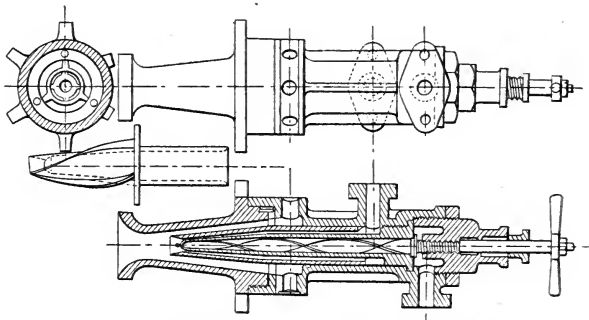

FIG. 337.—KERMODE STEAM AND INDUCED AIR BURNER.

electric-power plants, and fire-engines, as well as for drying-rooms for malt, tea, and timber-seasoning, and for heating public buildings. Its range of application is therefore very wide, and it may, in fact, be used wherever dry heat, cleanliness, and exact temperatures to be maintained or varied at will are needed. In respect of its use in glass-making it is pointed out that twice the number of men could be employed in an ordinary glass works if a constant heat were maintained in the furnaces, for with coal-firing there is much loss of time owing to the glass becoming too cold for working, when the men are idle for considerable periods.

One of the first successful burners of the pressure type, effecting atomisation of the oil without the use of steam or air, was the Swensson, the construction of which is shown in fig. 338. The oil is filtered or strained to remove any solid matter which might obstruct the burner, and is forced at high pressure (sometimes as much as 300 lbs. per square inch) through the large admission pipe into the body of the burner, thence travelling through the smaller orifices, issuing from the needle orifice, which is 1 mm. in diameter, and impinging with great velocity upon the knife edge, where it is broken up into fine spray. The needle shown in the centre of the section is provided for the purpose of clearing the



small orifice, into which it is driven by turning the milled head at the opposite end of the burner. It is returned to its normal position by a spring.

Another pressure burner which is largely used and gives excellent results is the Körtling (fig. 339). The oil supplied to this atomiser is pre-heated to a temperature of  $130^{\circ}$  C., and is forced through it under a pressure of 50 lbs. to the square inch. The burner is furnished, as will be seen from fig. 339, with a spiral screw surrounding the coned end of a central spindle, a spiral

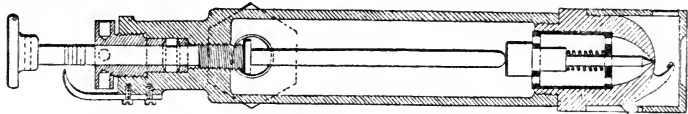

FIG. 338.—SWENSSON BURNER.

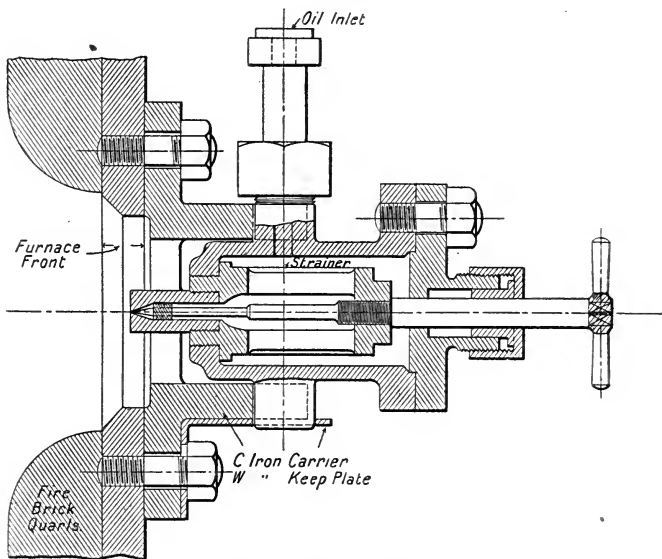

FIG. 339.—KÖRTING BURNER.

annular passage for the oil being thus formed. In travelling through this passage to the orifice of the jet the oil acquires a rotatory motion, and on escaping from the jet it is sprayed by centrifugal force in a finely divided state.

The Kermode pressure burner is illustrated by fig. 340. Forced or induced draught is recommended with this form of burner, and from 70 to 75 per cent. of the calorific value of the fuel is obtained. The oil enters the burner through the channel marked A in the figure and passes between the outer wall of the burner marked D, and the inner cylinder marked B, which abuts against the cap, E. The end of the cylinder, B, is an exact and true fit for the outer body, D, at the end where it abuts against the cap, E. A series of grooves is cut in the

plug end of B, parallel to the centre line of the burner, and similar grooves are cut in the face of the plug, B, at right angles to the axis of the burner. These grooves are shown in the view marked H, and it will be seen that they are tangential to the cone end of the spindle, C, which serves to contract or enlarge the opening through the cap nut, E. The movement of C is indicated on the

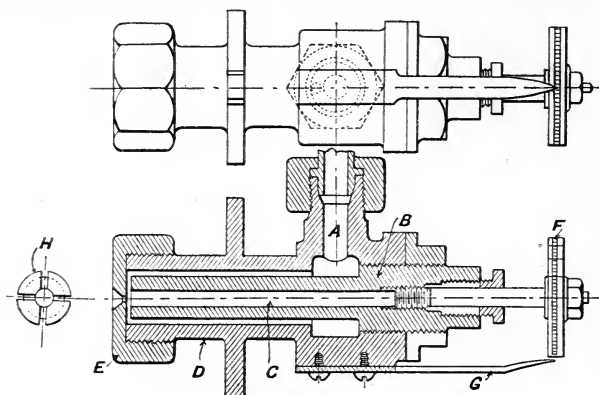

FIG. 340.—KERMODE PRESSURE JET BURNER.

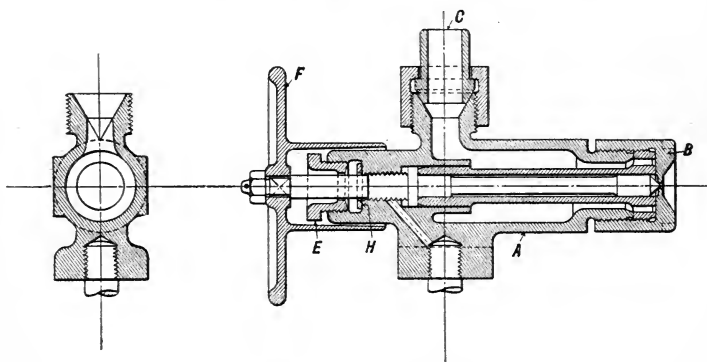

FIG. 341.—THORNYCROFT BURNER.

graduated wheel marked F. The oil fuel is thus pulverised effectively by being forced through a restricted opening with a rotary motion imparted by the tangential grooves, and being deflected by impinging on the conical end of the spindle, C, is distributed in the form of a cone. The fixed pointer serves to indicate the extent to which the orifice has been enlarged or contracted.

One of the most successful of the earlier forms of pressure burner was that which was patented by Sir John Thornycroft in 1906, and was the outcome of experience gained in the year 1896, when the steam lifeboat *Queen*

was built for the Royal National Lifeboat Institution by the firm of John I. Thornycroft & Co., Ltd.

A recent form of Thornycroft burner is shown in vertical section in fig. 341. The oil is fed through the pipe, C, into the annular space around the guide to the central spindle. This guide butts against the cap nut, B, and the oil passes through holes parallel to the long axis into a circular channel between the end

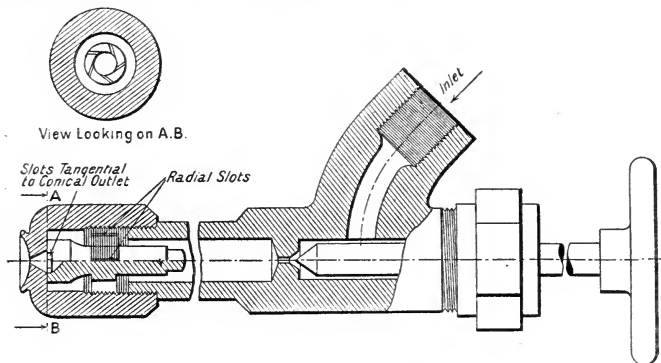

FIG. 342.—GORDEJEFF BURNER.

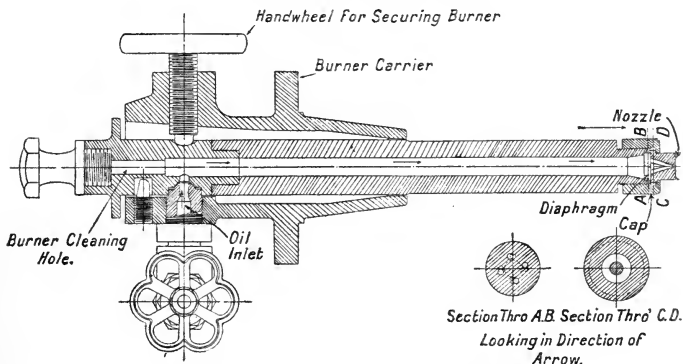

FIG. 343.—THE WALLSEND PRESSURE ATOMISER.

of the guide and the cap, and escapes under pressure through tangential grooves cut in the face of the guide. The oil is thus given a high rotary motion, and escapes through the burner opening, control of this opening being made by adjusting the position of the cone on the end of the central spindle by turning the hand-wheel, F.

Fig. 342 shows the construction of the Russian "Gordejef" burner, in which a whirling motion is likewise imparted to the oil by means of tangential jets.

An efficient form of burner for use with kerosene as a source of heat in

steam motor-cars, steam fire-engines, and boats has been devised by Clarkson and Capel. In this burner the oil is vaporised, and its vapour, in admixture with air, issues round the lip of a mushroom valve, where it burns with a large flaring flame of great heating power. With this burner an evaporation from and at 212° F. of nearly 11 lbs. of water per pound of oil is stated to have been obtained.

A pressure system which has been extensively fitted in the mercantile marine is the Wallsend-Howden system. The atomiser is shown in section in fig. 343. One of the main features is the four obliquely-bored orifices which ensures a whirling spray, the oil particles being thrown out in a well-spreading

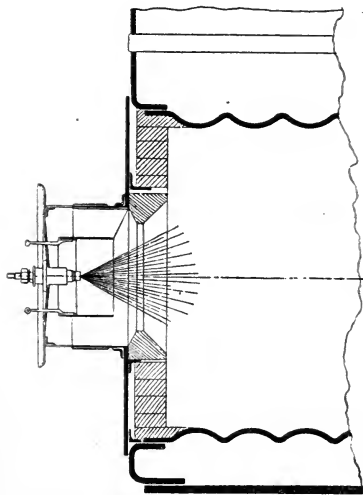

FIG. 344.—WALLSEND-HOWDEN SYSTEM FOR NATURAL DRAUGHT.

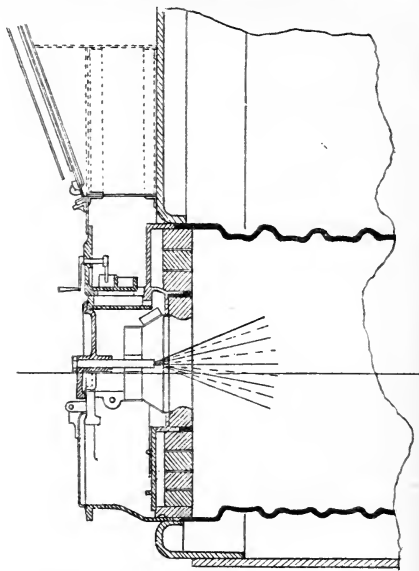

FIG. 345.—WALLSEND-HOWDEN SYSTEM FOR FORCED DRAUGHT.

cone. Another feature is the simplicity of the mounting which enables the atomiser to be quickly removed and replaced by a fresh one.

When working with natural draught or closed stokehold system of forced draught, the atomisers are mounted on an extension fitted to the front of the furnace. Each spraying nozzle projects through a baffle plate into an air-trunk having lateral openings at its outer end (fig. 344). This air-trunk projects concentrically with a second air-trunk carried by the furnace front, and the annular space between the inner and outer air-trunks is fitted with deflectors constructed to give the air passing through the annulus a spiral motion. Efficient mixing of air with the oil spray is thus assured. The admission of air through the second or outer air-trunk keeps the outer casing cool, and reduces radiation from this part to a minimum.

When working with forced draught on Howden's Heated Air System each

sprayer nozzle projects through the furnace door into a conical air distributor (fig. 345). This distributor is fitted with deflectors constructed to give the air passing through a spiral motion.

The compact arrangement of pressure-pump and oil-heater for sprayers operating on the pressure system is well illustrated in fig. 346, which shows a pumping-heating unit of the Wallsend-Howden system. Connection is made from the flanged pipe at the base plate with a duplex suction oil strainer (not

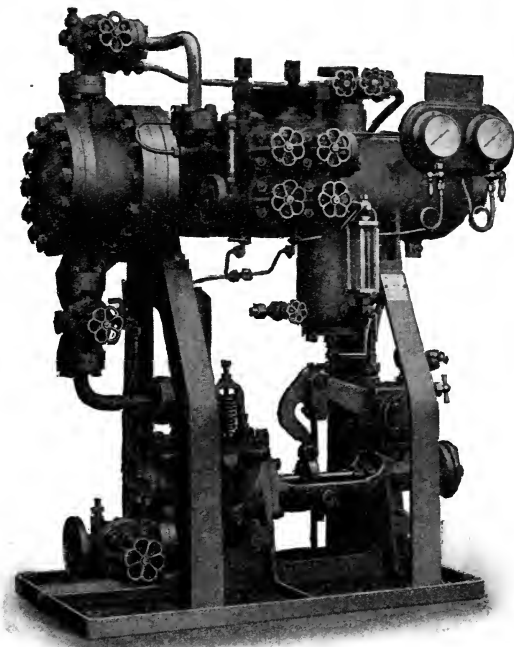

FIG. 346.—OIL PUMPING, HEATING, AND STRAINING UNIT INSTALLED IN THE WALLSEND-HOWDEN OIL FUEL SYSTEM.

shown), the oil is then forced by a Simplex oil fuel pump to the heater, which is carried by suitable brackets, the oil being discharged through one of a pair of discharge strainers (the four hand-wheels controlling the valves of these being shown in the upper centre of the illustration). A loaded relief valve between the suction and pressure sides of such pumping gear controls the maximum pressure at which the oil is ejected from the sprayers.

In a discussion of the subject of the combustion of oil fuel, more particularly for steam-raising, Prof. J. S. S. Brame<sup>1</sup> says:—"It cannot be too strongly

<sup>1</sup> *Journ. Inst. Pet. Techns.*, iii, 194 (1917).

emphasised that no particular type or pattern of atomiser possesses superlative superiority; that success in burning oil fuel depends but very little on the atomiser, providing the design is good in certain general particulars, but mainly on the general design of the whole oil-burning system.

“Another point, and one on which the U.S. Board laid great emphasis, is the tendency to install too few atomisers—a number of atomisers give a far more uniform heat, which is of great importance in the case of water-tube boilers, where the proper circulation of water will not take place if there is undue heating in certain parts. A number of atomisers reduces greatly the blowpipe-like action so frequently found.”

Discussing the relative merits of steam, air, and pressure atomisation in relation to the combustion process, the same writer says:—“Air is the natural atomising agent for perfect combustion. The very action of spraying ensures that each oil-vesicle is surrounded by oxygen ready to carry on the process. In the case of pressure atomising, provision must be made to introduce air most thoroughly throughout the cone of oil-spray, and this air should by preference be heated. Taking into consideration the effect of steam on the combustion process when this is the atomising agent, we find that various extravagant claims have been made for the action of steam.

“Steam actually displaces air which would naturally be present in the combustion spaces, and unless it can be shown, as some claim, that it indirectly assists in combustion of the oil, it is certainly an undesirable atomising agent as far as the actual combustion process is concerned.

“It is well known that the interaction between steam and hot carbon (the water-gas reaction) is markedly endothermic; if it occurs, it can only produce a lowering of the flame temperature in the zone of combustion; it would certainly result in the formation of carbon monoxide and hydrogen, and these gases would burn further on. The net result would be an extension of the flame, with no practical gain, for if the carbon is set free, and is at a sufficiently high temperature to react with steam, there is not the slightest fear that its combustion by oxygen directly to carbon dioxide, with higher thermal intensity, would not have taken place with air atomisation.” The same writer was unable to trace any proof of the supposed direct action of oil with steam likely to occur in the furnace which would assist combustion, and concluded that “for the practical application of oil fuel, steam atomisation has advantages, but from the combustion point of view the balance is against steam. There can be no question as to the soundness of design of steam-atomisers in which a good proportion of air is drawn in and intermingled with the steam and oil spray.”

Whatever system of atomising may be adopted, the construction of the furnace is of the highest importance, and it is especially needful that there should be a combustion-chamber of ample size, so that the combustion may reach the stage of the conversion of the carbon into carbon monoxide before the flame comes into contact with cooling surfaces. It is also essential that there should not be an excess of air supplied to the furnace, for whereas a little smoke may only mean the loss of 1 per cent. of the heat-giving power of the fuel, an excess of air may easily cause ten times this diminution in heating effect.

An instructive paper on “Unnecessary Losses in Firing Fuel Oil and an Automatic System for Eliminating Them,” by Mr. C. R. Weymouth, was read before the American Society of Mechanical Engineers in December 1908. The author points out that the customary method of procedure in the use of steam atomisers is to clamp the furnace dampers in a fixed position, to give little

attention to the steam supply, and to regulate by hand the supply of oil to the burners so as to maintain the desired steam pressure, with the result that there is an excess of air for combustion, particularly at the lighter loads. In some cases, where the engineers in charge are more enlightened as to the principles of combustion, and an attempt is made to work with a reduced air-supply, there is, on the other hand, at times an excessive production of smoke. The author states that with Californian oil from the Bakersfield district, which has a calorific value of 18,600 B.Th.U. (allowing for the presence of 1 per cent. of moisture), about 14 lbs. of air are required per pound of oil, and he shows then an ideal boiler efficiency of 84.2 per cent., obtained with a 10 per cent. excess air-supply, which is reduced to 67.09 per cent. with a 200 per cent. excess, the difference corresponding with a possible saving of over 20.32 per cent. in the fuel used. He further states that various tests have shown that the steam consumption ranges from 0.14 lb. to over 0.5 lb. of steam per pound of oil, the average value of good performances being about 0.3 lb. of steam per lb. of oil. These statements point to the importance of analysis of the flue gases in the installation of an oil-burning system, for in the use of oil fuel it is comparatively easy to secure the combustion of the fuel to  $\text{CO}_2$  with little excess of air. The automatic system advocated by Mr. Weymouth consists in controlling the oil supply by means of a "bleeder" valve, which increases or diminishes the pressure in the oil main and thus varies the rate of supply of the fuel. This valve is controlled by the steam-pressure in the boiler, and the variation in pressure in the oil main is the secondary means of controlling the supply of steam for atomising purposes and of air for combustion.

The steam-boiler is admittedly an imperfect and wasteful device for the conversion of the energy of fuel into power, and it is not surprising that inventors should have striven to find some means of eliminating its defects.

To Herr Brünler belongs the credit of being the first to practically demonstrate the possibility of steam-raising by the combustion of liquid fuel directly in contact with the water. An installation, which has been in operation in Bremen, consists of a cylindrical boiler, or water-container, provided with a number (corresponding to the number of burners employed) of smaller vessels or pockets, each of which can be isolated by a suitable valve, and can be drained by means of a draincock. Each of these pockets contains an oil-burner, as shown in fig. 347, with a pilot burner, by means of which the main burner can at starting be sufficiently heated to effect complete combustion of the oil. When the main burners are well alight, water is introduced into the previously drained pockets from the boiler by opening the valves, and the circulation of heated water commences, the products of combustion, together with the steam generated, being used as a source of power in a steam-engine. The flames can be observed through glazed sight-holes provided for the purpose. An experimental investigation of the Brünler system carried out by Professor Pictet demonstrated that there was no unburnt fuel in the products of combustion, and that 3 H.P. could be produced with the expenditure of about 2 lbs. of oil, quite 6 lbs. of good coal being needed to give the same result with the ordinary method of steam generation, even when one of the latest types of water-tube boilers is used. Allowing for the difference in thermal efficiency between oil and coal, the superior economy of the Brünler system is therefore very considerable, but there are several disadvantages in its employment. In the first place, it is evident that the air needed for the combustion of the fuel must be supplied at a pressure greater than that of the steam in the container. This necessitates the employment of powerful and costly air-compressors which absorb a large amount of the power available. Then,

again, it is requisite, in order to obtain the maximum efficiency, to highly superheat the steam and products of combustion, which cause difficulty in the lubrication of the engine. Finally, it is obvious that, owing to the presence of large quantities of carbon dioxide and nitrogen as products of combustion, it is practically impossible to run the engine with a vacuum, as the air-pump

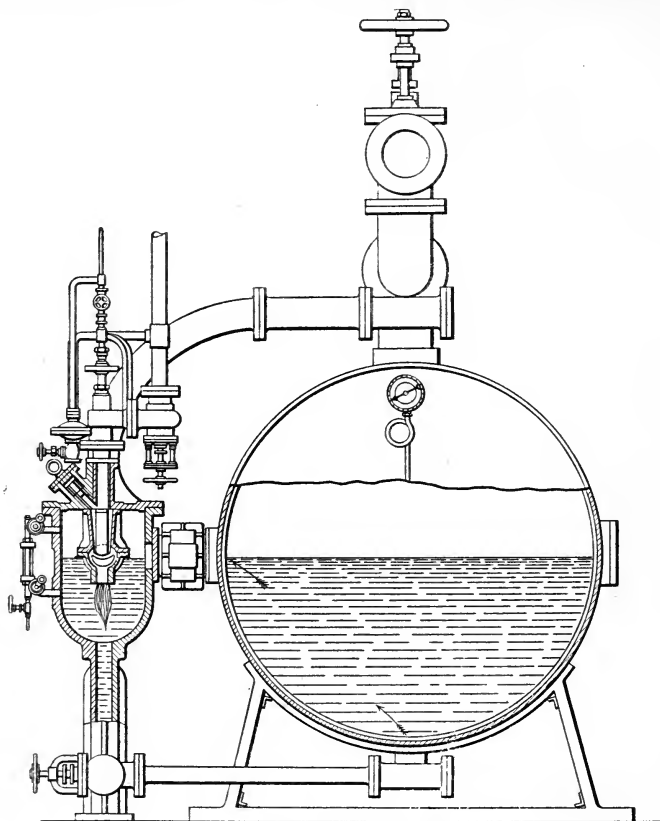

FIG. 347.—BRÜNLER SYSTEM.

would need to be of such large capacity that no increase of economy would result (the volumes of steam and gaseous products in the mixture supplied to the engine are in the proportion of 7 to 3). This renders it impossible to use the system for steam-generation for turbines, as it is well known that the turbine is not an efficient machine unless worked with a high vacuum. An additional difficulty which has been experienced arises from the circumstance that a considerable quantity of nitric acid is formed as one of the products of



combustion. It is, therefore, necessary to introduce chalk or some other neutralising agent into the container from time to time. It may, of course, be suggested that we have here a source of nitrates which may be made of commercial value, but on the whole it must be said that this highly ingenious invention is more interesting than practical, though there is no doubt that the system is well worth further study, and the principle has been applied to the evaporation of liquids in chemical manufacture.

### PETROLEUM-ENGINES.<sup>1</sup>

As already pointed out at the beginning of this section, petroleum-products are employed as a source of power in motors of the gas-engine type, and in one form of motor, petroleum spirit is used similarly to steam. The use of oil-gas and of air-gas, instead of coal-gas, in ordinary gas-engines, has also been referred to.

With the earlier forms of petroleum-engines it was necessary to employ mineral spirit; but with the modern types, ordinary kerosene, and oils of even higher boiling-points, may be used, the Diesel and the now extensively used semi-Diesel engines giving excellent results with the least volatile of the oils obtained from petroleum or shale, and even with the crude oils of South America and the oils known as Anglo-Mexican.

In the modern oil-engine the charge of oil taken from the supply-tank is converted into vapour or spray, which is carried by a current of air into the cylinder, or as a jet forced into a hot-bulb or other form of combustion-chamber, where it is mixed with the residue of the products of the combustion of the previous charge and with excess of air for combustion. This mixture is compressed and ignited. During explosion the burning gases expand, doing work on the motor-piston, and are finally ejected, as in the gas-engine.

The majority of oil-engines are constructed on the four-stroke cycle principle, first enunciated in 1862, by M. Beau de Rochas, a French engineer, and commonly known by his name. In this system, which is also termed the Otto cycle, Otto & Langen having been the first makers under de Rochas' theory, there is only one impulse to every four consecutive strokes, or every two revolutions of the crank. The first stroke draws in the charge of petroleum vapour and air, the second compresses the charge; at the commencement of the third, which is the effective stroke, the charge is ignited, with resulting explosion and expansion, and the fourth, termed the scavenging stroke, discharges the products of combustion from the cylinder.

It is obvious that this four-stroke cycle principle of construction is open to the objection that only one stroke out of four is a working stroke, and it is equally evident that in this cycle the engine is simply acting as a pump during the first and fourth strokes. It is, therefore, natural that attempts should have been made to substitute for it a method of working which would give an impulse for every revolution. This has been accomplished in engines of the two-stroke cycle type, to the construction of which greater attention is now being given. The crank-case is usually made to serve the purpose of a pump, the under side of the piston acting as the pump-piston. In those of high power a separate pump is used by some makers.

The advantages and disadvantages of the two systems of construction cannot be discussed in the space available in this work, and for further information on the subject the reader is referred to Askling's *Internal Combustion Engines and Gas Producers* (Charles Griffin & Company, Limited).

<sup>1</sup> Revised by Mr. W. Worby Beaumont, M.Inst.C.E.

In his report on the Warwick oil-engine trials of the Royal Agricultural Society, 1892,<sup>1</sup> and Cambridge trials, 1894,<sup>2</sup> it was pointed out by Mr. W. Worby Beaumont that engines as then made were divisible into seven classes and four main types.

Professor William Robinson, in 1902,<sup>3</sup> treated petroleum oil-engines as broadly divisible into four of these classes, according to the methods of vaporising and treatment of the petroleum in preparing the charge for combustion. To these must now be added a fifth class, represented by the Diesel engine, the modern semi-Diesel coming under the seventh class above referred to.

1. The measured charge of oil is sprayed by compressed air into a vaporiser heated by the exhaust-gases, and the vapour carried by the charge of air past the admission-valve into the motor-cylinder, where the mixture is further heated by the residual products and cylinder walls, compressed and fired, as in the Priestman and Griffin engines.

2. The oil is injected by a pump as fine jets of spray into the residual products of combustion and air contained in a red-hot cartridge or vaporiser always open by a narrow neck to the end of the motor-cylinder. The oil-vapour is mixed with excess of air, which is admitted to the cylinder by a separate valve, and the air is compressed by the motor-piston into the red-hot vaporiser and clearance-space forming the combustion-chamber, where the mixture is fired by compression against the heated surface, as in the Hornsby-Akroyd engine.

3. *First type.* A small vaporiser is kept red-hot by the flame from a lamp which also heats the ignition-tube, and the measured charge of oil is delivered by a pump and sucked through the vaporiser with a little hot air to carry the oil vapour through a separate valve into the cylinder, where it is mixed with the residual products, and the main supply of cold air drawn through another valve. Examples:—The Trusty, Clayton and Shuttleworth, Crossley, Fielding, Gardner, Howard, Blackstone, and other oil-engines. *Second type.* The oil is allowed to drop on a heated surface, and is swept along with the larger part of the charge of air previously heated, and then drawn through a vaporiser and admitted by a valve into the motor-cylinder, where it is mixed with the burnt products and little or no additional air. Examples:—The Roots and Premier oil-engines.

4. Each charge of oil is drawn in with the whole charge of cold air by the valve through the vaporiser into the combustion-chamber. The combustible mixture is compressed and ignited, as in class 3. Examples:—The Tangye and Campbell oil-engines.

In the Diesel oil-engine the liquid oil is injected through a spraying nozzle in finely divided particles into a large excess of air, highly heated by compression, in the motor-cylinder, where the mixture ignites spontaneously.

Mr. Donkin gives the following as the requirements which an oil-engine should meet:—

“It should be—(1) self-contained and quite independent, having everything requisite for its efficient working for a certain length of time. (2) Safe and simple, using as the working agent a combustible which is neither difficult to procure nor dangerous to transport. (3) Easy to handle, so that any ordinary unskilled workman can drive it. This is advisable, because these engines are frequently placed in the hands of labourers without any knowledge of machinery. (4) Compact and easily transported from place to place. (5) Economical in working.”

<sup>1</sup> *The Engineer*, 24th June 1892.

<sup>2</sup> *Ibid.*, 6th July 1894.

<sup>3</sup> *Gas and Petroleum Engines*, 2nd ed.

The following description of typical oil-engines, the Priestman, Hornsby-Akroyd, Trusty, Tange, and Diesel engines, is chiefly derived from the works of Mr. Bryan Donkin,<sup>1</sup> and Professor William Robinson:—<sup>2</sup>

The employment of petroleum spirit in engines was proposed soon after the introduction of the gas-engine, and in 1873 the Hock engine for use with benzoline was patented in Vienna. The ignition of the charge was effected in the following manner:—A small air-pump, driven from the crank-shaft, forced a current of air at each stroke into a small receiver filled with benzoline. The air became charged with benzoline, and a stream was directed through a nozzle against a permanent burner, placed close to an opening at the back of the cylinder. The benzoline ignited at the flame, a flap covering the admission-valve was lifted by the suction of the in-stroke, the flame drawn in, and the mixture in the cylinder ignited. The permanent burner was fed with petroleum spirit from the same receiver. The mixture in the cylinder was produced after the motor-piston passed the inner dead-point, by the simultaneous admission of benzoline and of air which atomised it. The whole cycle of operations occurred during a single forward and return stroke, the latter discharging the products of combustion.

The Brayton engine, patented in the United States in 1872, was the first in which ordinary kerosene was employed, and was known as the "Ready-motor." It was the first in which the principle of combustion at constant pressure was adopted, and was also the first in which the oil was sprayed. In this engine, air and petroleum are

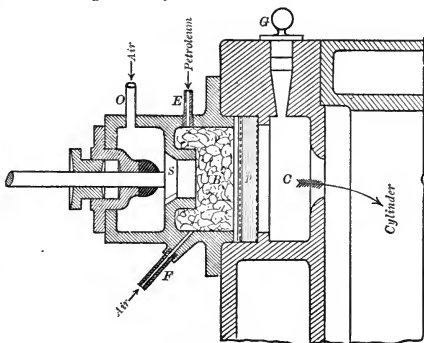

FIG. 348.—BRAYTON OIL-ENGINE.

both admitted at high pressure at F and E (fig. 348) into a carburettor placed at the top of the motor-cylinder and filled with felt, sponge, or other porous material. The air entering at F serves only to atomise the petroleum, the main air-supply being drawn in at O and through a valve, S. After passing through the carburettor, the air, which is then saturated with vapour, enters a chamber, C, which is constantly filled with flame, and is there ignited, the explosive combustion driving out the piston. The carburettor is separated from the chamber, C, by perforated metal plates which prevent the passage of flame. Ignition is effected in starting the engine, by inserting a match at G. After one-third of the piston-stroke, the valve, S, closes, and the charge expands during the remainder of the stroke. The products of combustion are expelled during the return-stroke.

The Priestman engine (figs. 349 and 350), which was brought out in 1888, is generally worked with kerosene, but oils of lower volatility may be employed. Ordinary lift-valves are used in this and most other oil-engines, as they are much less liable to become clogged. The oil-tank, which is fitted with a hand-pump, h, for use in starting the engine, contains sufficient oil to last for two or

<sup>1</sup> *Text-book on Gas, Oil, and Air Engines*, 1894. Fifth edition, with revision by Prof. Burstall and T. Graves Smith, 1911 (Charles Griffin & Company, Limited).

<sup>2</sup> *Gas and Petroleum Engines*, 2nd ed., 1902.

three days. Figs. 351 and 352 are enlarged views of the spray-maker and vaporiser.

A small air-pump, J, worked by the eccentric, *k*, which also controls the

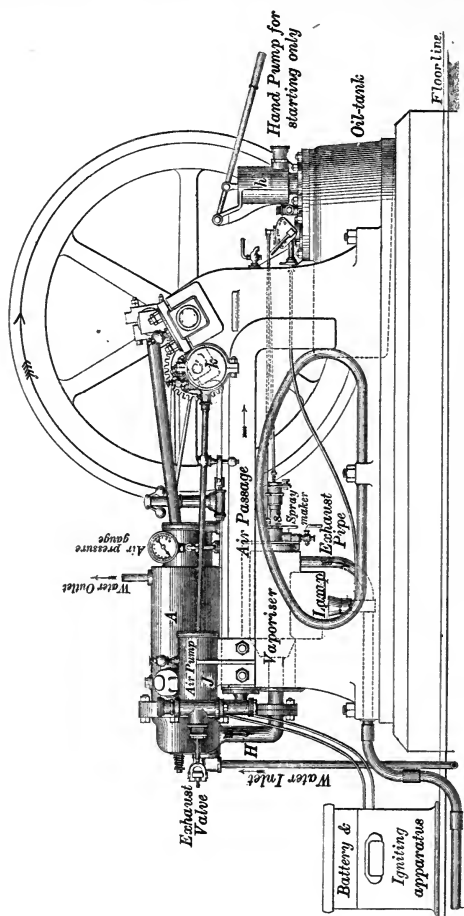

FIG. 349.—PRIESTMAN OIL-ENGINE.

exhaust-valve, draws in air through a cotton-wool filter, and compresses it into the oil-tank, at a pressure of from 8 to 15 lbs. above the atmospheric pressure. Streams of oil and air are thus driven into the spray-producer, S (fig. 349), through two concentric nozzles. The nozzles are peculiarly shaped, so that the oil is forced in very fine spray into the vaporiser, the amount of the charge thus entering being adjusted by the governor to the speed at which the engine

is working. As the spray enters the vaporiser, the in-stroke of the motor piston draws in air through a non-return valve, G, and a throttle valve, F (fig. 351). The air enters the vaporiser through a number of small holes, *d*, breaking up and mixing with the spray which it sweeps forward into the cylinder. The vaporiser consists of a front portion in which admixture occurs as described,

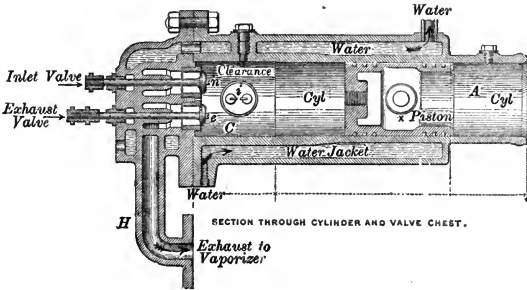

FIG. 350.—PRIESTMAN OIL-ENGINE.

and a back portion in which the oil in the charge is volatilised by the heat of the exhaust-gases (the products of combustion of the previous charge) which are led through a pipe, H (fig. 350), around the vaporising-chamber. This heating is essential, as the oil would otherwise partially separate from the spray before reaching the cylinder.

The ignition of the charge in the cylinder is effected as follows :—A battery

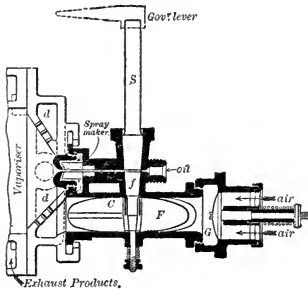

FIG. 351.—PRIESTMAN SPRAY-MAKER.

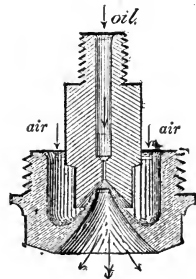

FIG. 352.—PRIESTMAN VAPORISER.

on the base plate of the engine is connected with platinum wires, *i* (fig. 350), in the compression-space of the motor-cylinder, and the spark passes when contact is established by a projection on the rod of the eccentric, *k* (fig. 349).

The engine works on the four-cycle principle already referred to. The first out-stroke draws in the charge ; the return-stroke compresses it into the space, C, at the back of the cylinder ; when the piston reaches the inner dead-point, the spark fires the charge, and the piston is propelled. On the return-stroke, the combustion-products pass through the valve, *e*, which is opened by the eccentric, and after passing round the vaporiser escape into the atmosphere.

The working is controlled by a governor, the entrance of oil being thus regulated by means of the spindle, *S* (fig. 351), which has a V-shaped opening at *f*, and the supply of air being adjusted by the use of a throttle, *F*. As a portion of the

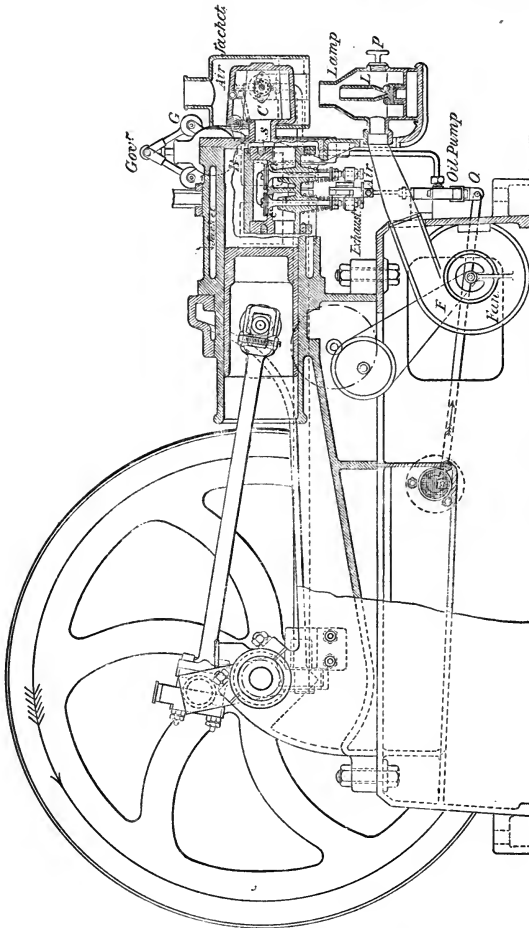

FIG. 353.—HORNSBY-AKROYD OIL-ENGINE.

oil is always condensed upon the cylinder, no other lubrication of the piston is required.

The working cylinder is surrounded by a water-jacket as in gas-engines, to prevent the accumulation of heat. The loss of power arising from this cooling was estimated by Professor Unwin, in the case of a 5 h.-p. engine, at 47.54 per

cent., and the loss from the heat remaining in the exhaust-gases at 26.72 per cent., the total heat utilised being 16.12 per cent.

In the **Hornsby-Akroyd** oil engine (fig. 353), the explosion is effected by injecting the oil into a red-hot chamber ("cartridge"), C, into which heated air is forced by the piston. The mixture ignites spontaneously as the piston reaches the inner dead-point and the return stroke is thus produced. The engine works on the four-cycle system employed in the "Priestman." The cartridge, C, is kept at a uniform temperature by an air-jacket, and is heated at starting by means of a lamp, L, fed with oil from the tank which supplies the engine. A fan, F, worked by hand, supplies air to the lamp, and the oil burns from a small piece of asbestos or other absorbent material, inserted at P. After the chamber, C, is heated, the working of the engine suffices to maintain its temperature.

The air- and exhaust-valves, *cd*, are controlled from a shaft driven at half-speed by the crank-shaft. They communicate with the cylinder through the same opening, so that the heat of exhaust warms the fresh air as it enters. This air is driven by the piston into the cartridge, and there mixes with the vapour of a very small quantity of oil which is injected through a nozzle, but without being sprayed, by a pump, O. When the inner dead-point of the piston is reached, the explosion occurs, and the gases travel through a small passage, *s*, into the compression space, B, of the cylinder. The governor, G, controls a small valve through which the oil enters the cartridge, C, and a by-pass valve which allows the oil to return to the tank when not utilised. A water-jacket round the valve-box keeps the oil cool until it reaches the cartridge.

With this engine, oil of specific gravity 0.850 and flashing-point 150° F. can, it is stated, be used. Only about 0.015 of a cubic inch of oil is injected at each stroke of the pump, O, in the case of a 6 horse-power engine.

In the **Trusty** oil engine (fig. 354), which is also of the four-cycle type, the oil is drawn through a pipe, *p*, from a tank below the engine, by a pump, P, and is forced through a pipe, *p*<sup>1</sup>, into a receiver, C. From this it passes drop by drop into the cylinder-jacket or vaporiser, V, through a glass tube and a valve, H. The jacket is sufficiently hot to volatilise the oil, and the vapour is drawn, together with air admitted by a valve, S<sup>1</sup>, into the compression end of the cylinder. On the return stroke of the piston, a portion of the mixture passes into an igniting-tube, I, and the charge is exploded. The tube, I, is maintained at a red heat by a lamp, J.

The oil-pump rod, Q, is actuated by a hit-and-miss device, M, controlled by a pendulum governor, G. A lever, D, is interposed so that the pump is not worked if the speed becomes excessive. The lever also acts upon the valve, H,

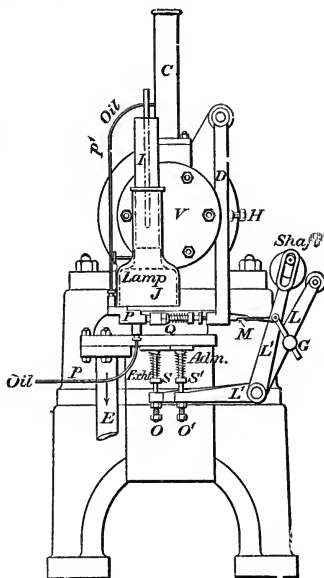

FIG. 354.—TRUSTY OIL-ENGINE.

the oil-supply being thus doubly controlled. The air- and exhaust-valves, SS<sup>1</sup>, are adjusted by screws, OO<sup>1</sup>, and are controlled through levers, LL<sup>1</sup>, from a shaft driven at half-speed from the crank-shaft. The exhaust outlet is at E.

In this engine, Broxburn lighthouse-oil of specific gravity 0.81 and flashing-point 150° F. is successfully used. The engine runs at high speeds, and gives a good heat efficiency.

The **Tangye** oil-engine is of very simple construction. There is no pump, the oil flowing by gravitation from a tank on the top of the cylinder through a fine passage in the conical seat of the admission-valve. The oil-supply for each charge is adjusted by a simple device at the supply-tank. There are only two valves; the inlet-valve, for the admission of air and oil, is automatic, and is held on its seat by an adjustable spring; the exhaust-valve is opened by a lever and cam on the side-shaft in the usual way. The vaporiser is always open by a neck to the combustion-chamber, and by a small port to the ignition-tube. The vaporiser has an air-jacket with a chimney, which can be closed or opened to regulate the temperature according as the engine is running with light loads or fully loaded. Before starting the engine the vaporiser is heated by means of a lamp fed with oil by gravitation, and afterwards the lamp is shifted to heat the ignition-tube. When the admission-valve is drawn down by the vacuum caused by the suction-stroke of the motor-piston, the charge of oil around the seating of the valve falls and is carried by the air as oil-mist and vapour through the vaporiser into the cylinder. During the compression-stroke, the combustible charge is further mixed and forced into the combustion-chamber, and then fired by the ignition-tube in the vaporiser, driving the piston forward on its next working-stroke. The engine is governed by Tangye's incline inertia governor arranged to sprag or hold the exhaust-valve open when the speed is too high. In this way the piston pumps the burnt products in and out of the exhaust-box; no vacuum can form in the cylinder during the suction-stroke, and consequently the admission-valve remains closed and cuts off the charge of both oil and air.

A series of consumption-tests of oil-engines was made for the Royal Agricultural Society in 1901 by Professor Ewing. The oil used was American kerosene of Royal Daylight brand, having a specific gravity of 0.801 and a flashing-point of 86° F. The calorific value of the oil was 10,329 calories per gram. The trials, numbered 1 to 5, extended over five days, and were made on five kinds of engines constructed by leading manufacturers in this country. The following figures give the lowest and highest consumption respectively per brake h.p. per hour on full load:—

No. 1 of 15 b.h.p.,	0.69 to 0.74 lb.
No. 2 of 12 b.h.p.,	0.69 to 0.80 lb.
No. 3 of 12 b.h.p.,	0.81 to 0.86 lb.
No. 4 of 12 b.h.p.,	1.09 to 1.30 lb.
No. 5 of 6 b.h.p.,	1.07 to 1.18 lb.

In the **Diesel** oil-engine a large excess of air is used, and the common four-stroke cycle is usually followed, with adiabatic compression of the air alone in the cylinder to about 35 atmospheres. During the working-stroke, oil in the liquid state, injected as fine spray through a nozzle by compressed air into the large excess of "red-hot" air, is instantly vaporised and burned, because each particle of oil finds sufficient oxygen for its combustion. After the point of release, and in the upstroke of the piston, the gases are ejected. Fresh air is again drawn in during the down-stroke, and compressed to the temperature of combustion or an approach to it before the



introduction of the next charge. The action is like that of the early form of Akroyd engine, with extremely high compression for the injection of the oil.

The Diesel engine is also made with means for oil-injection unmixed with injection air—that is, the oil is injected as a jet, and is called solid injection. The oil is, however, by its injection at very high pressure broken instantaneously in fine spray and is ignited and burned at approximately constant pressure, ignition resulting from the high temperature due to compression.

According to Professor Unwin, the Diesel engine exhibits a far higher economy than the ordinary type of oil-engine, and will convert no less than 37 per cent. of the heat generated by the combustion of the oil into *indicated* work. The Augsburg Manufacturing Company guarantee that Diesel engines of any size will run with 0.452 lb. of solar or crude petroleum per b.h.p. per hour, and that at half power the consumption will not exceed 0.520 lb. Professor Meyer, of the Charlottenburg Technical High School, found that a Diesel engine tested at normal load consumed 0.467 lb. per b.h.p. per hour; at three-quarter load, 0.488 lb.; and at half-load, 0.567 lb.

The Diesel type of internal-combustion engine has not only been increasingly employed as a stationary source of power, but has been successfully applied in the propulsion of ships. It seems probable that for marine work the two-stroke cycle type of engine, with a separate pump, will be adopted. Much difficulty has been experienced in providing means for adequate cooling with cylinders of large size, and generally in meeting the requirements of marine work. Heavy-oil engines have also been substituted for petrol engines in submarines. As the steam-engine ordinarily furnishes only about 12 per cent. of the energy of the fuel in the form of work, the ordinary forms of internal-combustion engine 27 per cent., and the Diesel engine over 30 per cent., there is great inducement to overcome the difficulties attending the construction of oil-engines of very high power, such as are needed for the propulsion of the largest passenger vessels and battleships. Recent improvements in marine steam-boilers, steam turbines, and the super-heating of the steam, have, however, largely increased the efficiency of the steam-engine, and this must now be taken into account in estimating the relative thermal efficiency of the Diesel engine.

An instructive account of the type of motor known as the semi-Diesel engine was recently given by Mr. James Richardson in a paper read before the Diesel Engine Users' Association. In designing this type of internal-combustion engine it has been sought to retain the feature of low fuel consumption of the Diesel engine, whilst eliminating the need for the very high compression requisite in that engine to secure the ignition of the charge, and at the same time to prolong the pressure during the stroke. This is accomplished in the so-called semi-Diesel engine by providing a heating device generally in the form of a bulb constituting a combustion space extension of the cylinder. Mr. Richardson defined the semi-Diesel engine, in the paper referred to, as an internal-combustion engine, using oil fuel, having an uncooled portion of the combustion chamber at high temperature, to assist in the vaporisation and ignition of the injected oil, excluding, however, from the definition certain oil-engines, *e.g.* the Hornsby-Akroyd, which, although not called Diesel engines, yet approximated to this type as relying upon the heat of compression for ignition.

The so-called semi-Diesel engine is a rather high compression engine in which the fuel oil is forced, in the form of a solid jet, into a combustion space, combustion taking place at constant volume.

Much doubt has been expressed as to the propriety of calling these engines

semi-Diesel, on the ground that they are in general principle and working the same as those of engines made and used in England long before any engine according to Diesel had become practical.

Most of these engines are constructed on the two-stroke cycle, the crank-chamber being made airtight. The lower end of the engine piston forms an air-pump taking air into the chamber and slightly compressing it on the down-stroke of the piston.

These engines are made in slightly varying forms by several makers, including Messrs. W. Beardmore & Co., Glasgow; Messrs. Marshall, Gainsborough; Messrs. Robey & Co., Lincoln; The Campbell Engine Co.; Messrs. Petter, Ltd., of Yeovil; Tangyes, Ltd., and others, including the makers of the Bolinder engine, the Ailsa Craig, the Kromhout, and the Ruston-Hornsby.

Fig. 355 shows a single-cylinder Petter V.J. engine of 50-brake horse-power, and figs. 356 and 357 are sectional views of the arrangement of the V.E. 35-brake horse-power engine of similar design.

At A is seen a hot bulb which is really an extension of the usual combustion-chamber and is covered by a removable cover. It will be seen that the combustion-chamber is water-jacketed except for the upper part.

As shown, the piston is in its highest position and will have drawn in the charge of air into the crank-chamber through the valves, B B, on either side of the chamber.

On the descent of the piston these valves automatically close and the air in the chamber is under slight compression and ready to pass by the port, C, into the upper part of the cylinder when the piston has reached a position which admits the air thereby.

In order to make the chamber airtight and prevent escape during the descent of the piston past the bearings, there is a valve-forming ring, D, on either side of the crank, as seen in fig. 357. Oil is supplied to the crank-pin by centrifugal action through the banjo ring, E.

An oil-pump, F, for the fuel oil is operated by the eccentric, G, as seen in figs. 356 and 357, the oil from the pump passing to the jet pieces at H, and thence as a solid jet into the hot bulb where it impinges on the interior surface and is thoroughly broken up and ignited.

These engines are made as single-cylinder engines up to 70-brake horse-power and as multi-cylinder engines up to 300-brake horse-power. The Bolinder two-stroke cycle engine and the Kromhout engines have bulbs somewhat similar, but not removable arranged as in the Petter engine, but both these engines are in use in the barges used as tugs on canals such as the Grand Junction.

The upper half of the hot bulb in the Beardmore engine is arranged for removal and renewal somewhat as in the Petter engine, both engines having large-area water-jacket spaces, and both using what is called the slot fuel-oil jet in distinction from the air-spray made jet.

In the Petter and some other of these engines variable speed and power is arranged for by difference in the period at which the injection takes place, and the engines can thus be satisfactorily run with speed variations down to two-thirds of the normal and even less.

Arrangements are also made by means of which these two-stroke cycle engines are reversible.

The first edition of this book was written at a time when public attention was first being directed to the application of the internal-combustion engine to the propulsion of road-vehicles, and it was therefore appropriate that some

account should therein have been given of the pioneer work of Panhard and Levassor, and Peugeot in the construction of automobiles. Since then the motor-car industry has rapidly assumed vast proportions, and the use of petroleum spirit as a source of power on the road is now general all over the world.

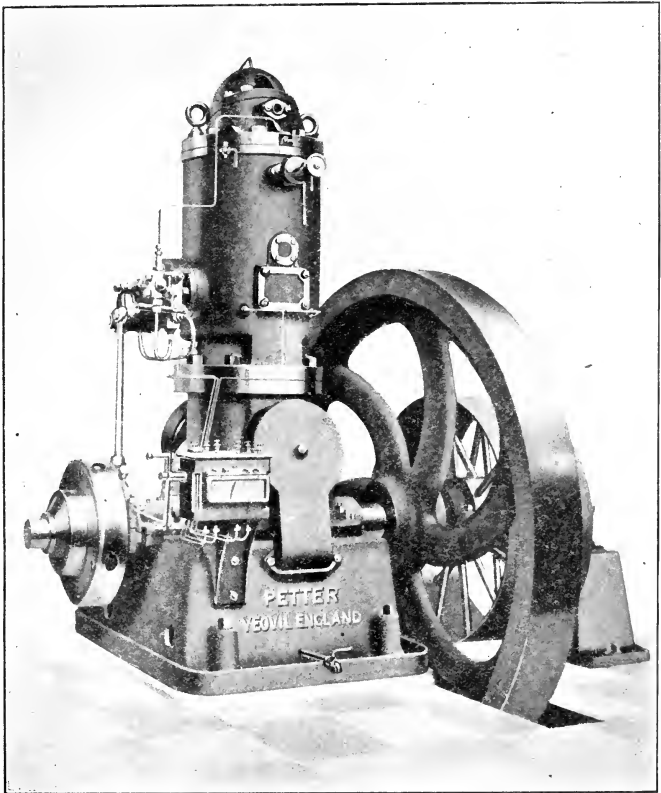

FIG. 355.—SINGLE-CYLINDER TWO-STROKE CYCLE HEAVY-OIL ENGINE BY MESSRS. PETTER, LTD., YEovil.

The employment of similar engines for the propulsion of small vessels has also increased very rapidly,<sup>1</sup> and remarkably high speeds have been attained. Concurrently the literature of the subject has become voluminous, many lengthy treatises on road-vehicles having been published, and several periodicals being exclusively devoted to automobilism. In the circumstances, it is

<sup>1</sup> The Thames Conservancy Bye-laws for the regulation of petrol motor launches on the River Thames will be found among the appendices.

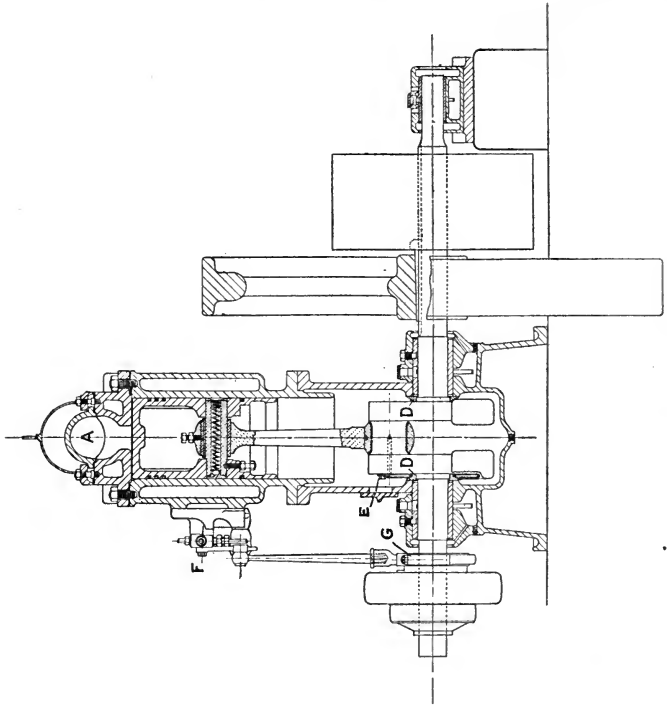

FIG. 357.

SECTIONS OF PETER SEMI-DIESEL OIL-ENGINE.

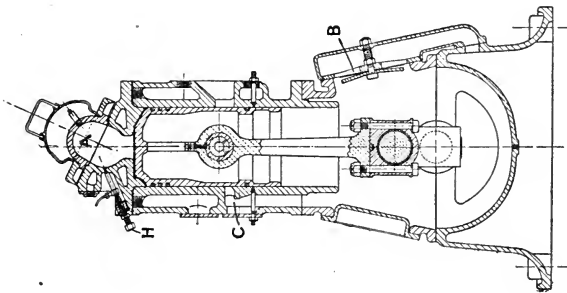

FIG. 356.

impossible within the space available in this work to include any comprehensive account of the various forms of motor-car and motor-boat engines at present so largely used ; but the following description of the Daimler engine, given in the second edition, may be reproduced, as it was the invention of this high-speed petroleum-spirit motor that led to the rapid development of the automobile industry. The modern Daimler engine as fitted to the Mercédès motor car constructed by the "Daimler Motoren Gesellschaft" has four vertical cylinders cast in pairs, both these and the combustion-chamber being cooled by a water-jacket. The petrol is forced upwards from the supply-tank through a strainer or filter of wire gauze, by the pressure of a small portion of the exhaust, into a needle-float feed carburettor. Mechanically operated inlet-valves of exceptionally large area are employed, and the ignition of the charge is effected by a low-tension magneto apparatus known as the Simms-Bosch. This apparatus generates a current of low tension but large in quantity, the spark being produced when the circuit is broken. This rupture of the circuit is effected by mechanical means in the combustion-chamber. The speed of the engine is controlled by a plunger-throttle placed in the induction-pipe between the carburettor and engine. This throttle is operated by a lever on the steering-wheel.

None of the recent engines bear any likeness to the original Daimler engine, except as to high speed of revolution. The main features of the engines in the Mercédès have been retained on the lines first indicated by Panhard and Levassor, but greater precision in valve movements, giving silent working, larger water-jacket spaces, forced lubrication, and longer stroke in proportion to diameter of cylinder, have been very generally adopted. The engines of the Daimler Company of Coventry are fitted with sleeve valves instead of the tappet or mushroom valves used by some other makers. These sleeve valves consist of two thin cylinder liners to which relative motion is given, the upper parts of the sleeves being pierced for ports which register at proper time with the usual inlet and outlet ports of the cylinder. The usual piston works within the inner sleeve. The engines are silent in working. The Argyll Motor Company also make an engine with a single sleeve valve, but nearly all other makers use the tappet valves.

In modern motor-car engines, governing is effected by throttling the charge, *i.e.* by diminishing the volume of charge admitted to the cylinder, and the favourite type of ignition is the high-tension magneto, the current being generated in the primary windings and transformed by the secondary winding on the armature of the magneto, and reaching the sparking-plugs by way of a rotary distributor.

Petrol-driven locomotives are largely employed in coal- and other mines on the European continent, and petrol engines are used in England for driving tram cars.

In engines intended for the propulsion of aeroplanes and airships, special principles of construction are adopted to minimise weight. In one form a number of cylinders are fixed at equal distances in the semicircular upper half of the crank-case, whilst in the Gnome engine, the seven or fourteen cylinders rotate round the fixed crank-shaft.

The "Zephyr" launch-engine, introduced into this country by Messrs. Yarrow, is of interest, as the vapour of petroleum spirit, of specific gravity 0.68, is employed in the same manner as steam as an expansive agent. While the vapour of such petroleum spirit may be cooled to 130° F. without condensation, it exerts a vapour-pressure of 10 lbs. per square inch at 155° F., and of 40 lbs. per inch at 212° F., at which temperature water, of course, has a vapour-

pressure of about 15 lbs. For the same amount of heat, therefore, petroleum spirit gives a higher pressure than does water, and a correspondingly smaller amount of heat is lost in the exhaust, so that a higher heat-efficiency is obtained. Meiro <sup>1</sup> states that although the vapour-pressures of different samples vary considerably at low temperatures, there is practically no difference at temperatures above 85° C. Thus, one sample of specific gravity 0.71 showed a pressure of 0.065 kilo. per square centimetre at 29° C., while another sample of specific gravity 0.715 yielded that pressure at 43° C. Both samples gave a pressure of about 2 atmospheres at 85° C. The working of the engine is similar to that of a surface-condensing steam-engine. The engine and vapour-generator are carried in the stern of the boat, and the reservoir of spirit in the bow. The spirit is volatilised in a spiral tube enclosed in a non-conducting casing and heated by a burner. The vapour propels the piston as in a steam-engine, and exhausts into two cooling-pipes, from which the condensed liquid returns to the reservoir. Thus, the spirit is used repeatedly without coming into contact with the air, and only a comparatively small quantity of spirit has to be stored.

The vaporiser may be heated by burning part of the petroleum spirit in an atmospheric burner, but the better and commoner plan is to use ordinary kerosene. This is sprayed by a small air-pump driven by the engine, and is burned in a fire-box beneath the vaporiser after being mixed with a further supply of air.

<sup>1</sup> *Chem. Zeit. Rep.*, 1893, 158.

## SECTION XI.

### STATUTORY, MUNICIPAL, AND OTHER REGULATIONS RELATING TO THE TESTING, STORAGE, TRANSPORT, AND USE OF PETROLEUM AND ITS PRODUCTS.

#### BRITISH.

As the general use of mineral oils as illuminating agents may be said to date only from 1859, all legislation in relation to petroleum has been effected within comparatively recent years. In this country, the first Act was passed in 1862 (25 & 26 Vict. cap. 66). It was entitled "An Act for the safe-keeping of petroleum," and the preamble was as follows:—

"Whereas it is expedient to provide for the safe-keeping of petroleum and certain products thereof that are dangerous to life and property, from their properties of giving off inflammable vapours at low temperatures," etc.

This Act defined "petroleum" for the purposes of the Act as including "any product thereof that gives off an inflammable vapour at a temperature of less than 100° of Fahrenheit's thermometer." Not more than 40 gallons of "petroleum" (as defined in the Act) was to be stored within 50 yards of a dwelling-house or warehouse, except under license from the local authority, who might impose any conditions considered necessary for the public safety. Carriage in a vessel within a harbour was subject to the regulations of the harbour authorities only, and the powers of search given in the Gunpowder Act, 1860, were extended to "petroleum" under this Act. As no method of testing was specified, it was practically impossible to put the Act into operation.

An amending Act was accordingly passed in 1868 (31 & 32 Vict. cap. 56), and in this there was an extended definition of "petroleum" which has been given in Section IX. (p. 763). In this Act, which "so far as is consistent with the tenor thereof" was directed to be read as one with the previous Act, storage without a license, within the 50 yards limit, was disallowed, except in the case of petroleum for private use, and as regards such petroleum no limit of quantity was fixed. The "bottle or vessel" containing "petroleum" (as defined in the Act) was required to bear the following label:—

"Great care must be taken in bringing any light near to the contents of this vessel, as they give off an inflammable vapour at a temperature of less than 100° of Fahrenheit's thermometer."

Any duly appointed inspector of weights and measures was empowered to "inspect and test all petroleum kept, offered, or exposed for sale," and any petroleum so kept, or offered, or exposed for sale in contravention of that Act, or of the previous Act, was liable to be seized, and upon conviction, forfeited, the person or persons offending being liable to a penalty of five pounds. Such person or persons might, however, appeal against the test of the inspector, and

in such case the court might submit the question to the public analyst, or if no such official had been appointed, to "some other person having competent chemical knowledge."

The practical effect of this legislation was that two classes of petroleum products were imported into this country: one (kerosene) conforming, or intended to conform, to the requirements of the law, and the other (petroleum spirit) giving off inflammable vapour at all ordinary temperatures, and even far below them.

In 1871 another Act (34 & 35 Vict. cap. 105) was passed, and as this is still in force, except as to the standard or limit of test and the mode of testing, it is given below in full, the schedules only being omitted. The first of these schedules is a reproduction of the directions for testing given in the schedule of the Act of 1868, and the second specified the Acts repealed by Section 17, as follows:—The Petroleum Act, 1862, the Carriage and Deposit of Dangerous Goods Act, 1866, and the Petroleum Act, 1868. This Act was to continue in force until 1st October 1872, but was continued from year to year by the Expiring Laws Continuance Acts.

CHAP. 105.

An Act for the safe keeping of Petroleum and other substances of a like nature.

[21st August 1871.]

WHEREAS it is expedient to consolidate and amend the law relating to the safe keeping of petroleum and other substances of a like nature:

Be it enacted by the Queen's most Excellent Majesty, by and with the advice and consent of the Lords Spiritual and Temporal, and Commons, in this present Parliament assembled, and by the authority of the same, as follows:

1. This Act may be cited as "The Petroleum Act, 1871."

2. In this Act, if not inconsistent with the context, the following terms have the meanings hereinafter assigned to them; (that is to say),

The term "borough" means—

In England any place for the time being subject to the provisions of the Act of the session of the fifth and sixth years of the reign of King William the Fourth, chapter seventy-six, "to provide for the regulation of municipal corporations in England and Wales," and the Acts amending the same;

In Scotland any royal burgh and any burgh or town returning or contributing to return a member or members to serve in Parliament;

In Ireland any place for the time being subject to the provisions of the Act of the session of the third and fourth years of the reign of Her present Majesty, chapter one hundred and eight, "for the regulation of municipal corporations in Ireland, and the Acts amending the same":

The term "person" includes a body corporate:

The term "Secretary of State" means one of Her Majesty's Principal Secretaries of State:

The term "Lord Lieutenant" means the Lord Lieutenant of Ireland or the lords justices or other chief governors or governor of Ireland for the time being:

The term "harbour" means any harbour properly so called, whether natural or artificial, and any port, haven, estuary, tidal river or other river, canal or inland navigation navigated by sea-going ships, and any dock, pier, jetty, or other works in or at which ships do or can ship or unship goods or passengers:

The term "harbour authority" includes any persons or person being or claiming to be proprietors or proprietor of or intrusted with the duty or invested with the power of improving, maintaining, or managing any harbour:

The term "ship" includes every description of vessel used in navigation, whether propelled by oars or otherwise:

The term "Summary Jurisdiction Acts" means as follows:

As to England, the Act of the session of the eleventh and twelfth years of the reign of Her present Majesty, chapter forty-three, intituled "An Act to facilitate the performance of the duties of justices of the peace out of sessions within England and Wales with respect to summary convictions and orders," and any Acts amending the same;

As to Scotland, "The Summary Procedure Act, 1864";

As to Ireland, within the police district of Dublin metropolis, the Acts regulating the powers and duties of justices of the peace for such district, or of the police of such district; and

A.D. 1871.

Short title of Act.

Interpretation of certain terms in the Act:

"Borough":

"Person":

"Secretary of State":

"Lord Lieutenant":

"Harbour":

"Harbour authority":

"Ship":

"Summary Jurisdiction Acts":



elsewhere in Ireland, "The Petty Sessions (Ireland) Act, 1851," and any Act amending the same :

The term "Court of Summary Jurisdiction" means and includes any justice or justices of the peace, sheriff or sheriff-substitute, metropolitan police magistrate, stipendiary or other magistrate, or officer, by whatever name called, to whom jurisdiction is given by the Summary Jurisdiction Acts or any Acts therein referred to, or to proceedings before whom the provisions of the Summary Jurisdiction Acts are or may be made applicable :

The term "county rate" means as regards Scotland the county general assessment leviable in pursuance of "The County General Assessment (Scotland) Act, 1868," and as regards Ireland the grand jury cess.

3. For the purposes of this Act the term "petroleum" includes any rock oil, Rangoon oil, Burmah oil, oil made from petroleum, coal, schist, shale, peat, or other bituminous substance, and any products of petroleum, or any of the above-mentioned oils ; and the term "petroleum to which this Act applies," means such of the petroleum so defined as, when tested in manner set forth in Schedule One to this Act, gives off an inflammable vapour at a temperature of less than one hundred degrees of Fahrenheit's thermometer.

4. Every harbour authority shall frame and submit for confirmation to the Board of Trade byelaws for regulating the place or places at which ships carrying petroleum to which this Act applies are to be moored in the harbour over which such authority has jurisdiction, and are to land their cargo, and for regulating the time and mode of, and the precautions to be taken on, such landing. The harbour authority shall publish the byelaws so framed with a notice of the intention of such authority to apply for the confirmation thereof. The Board of Trade may confirm such byelaws with or without any omission, addition, or alteration, or may disallow the same.

Every such byelaw when confirmed shall be published by the harbour authority, and may be from time to time altered or repealed by a byelaw made in like manner. Byelaws under this section shall be published in such manner as the Board of Trade may from time to time direct.

If at any time it appears to the Board of Trade that there is no byelaw for the time being in force under this section in any harbour the Board of Trade may, by notice, require the harbour authority of such harbour to frame and submit to them a byelaw for the purposes of this section, and if such harbour authority make default in framing a byelaw and obtaining the confirmation thereof within the time limited by such notice the Board of Trade may make a byelaw for the purposes of this section, and such byelaw shall have the same effect as if it had been framed by the harbour authority and confirmed by the Board of Trade.

Where any ship or cargo is moored, landed, or otherwise dealt with in contravention of any byelaw for the time being in force under this Act in any harbour, the owner and master of such ship, or the owner of such cargo, as the case may be, shall each incur a penalty not exceeding fifty pounds for each day during which such contravention continues, and it shall be lawful for the harbour-master or any other person acting under the orders of the harbour authority of such harbour to cause such ship or cargo to be removed at the expense of the owner thereof, to such place as may be in conformity with the said byelaw, and all expenses incurred in such removal may be recovered in the same manner in which penalties are by this Act made recoverable.

5. The owner or master of every ship carrying a cargo any part of which consists of petroleum to which this Act applies, on entering any harbour within the United Kingdom, shall give notice of the nature of such cargo to the harbour authority having jurisdiction over such harbour.

If such notice is not given the owner and master of such ship shall each incur a penalty not exceeding the sum of five hundred pounds, unless it be shown to the satisfaction of the court before which the case is tried that neither the owner nor the master knew the nature of the goods to which the proceedings relate, nor could with reasonable diligence have obtained such knowledge.

6. Where any petroleum to which this Act applies—

- (a) Is kept at any place except during the seven days next after it has been imported ; or,
- (b) Is sent or conveyed by land or water between any two places in the United Kingdom ; or,
- (c) Is sold or exposed for sale ;

the vessel containing such petroleum shall have attached thereto a label in conspicuous characters, stating the description of the petroleum, with the addition of the words "highly inflammable," and with the addition—

- (a) In the case of a vessel kept, of the name and address of the consignee or owner :
- (b) In the case of a vessel sent or conveyed, of the name and address of the sender :
- (c) In the case of a vessel sold or exposed for sale, of the name and address of the vendor.

All petroleum to which this Act applies which is kept, sent, conveyed, sold, or exposed for sale, in contravention of this section, shall, together with the vessel containing the same, be forfeited, and in addition thereto the person keeping, sending, selling, or exposing for sale the same shall for each offence be liable to a penalty not exceeding five pounds.

7. Save as hereinafter mentioned, after the passing of this Act petroleum to which this Act

applies shall not be kept, except in pursuance of a license given by such local authority as is in this Act mentioned.

All petroleum kept in contravention of this section shall, together with the vessel containing the same, be forfeited, and in addition thereto the occupier of the place in which such petroleum is so kept shall be liable to a penalty not exceeding twenty pounds a day for each day during which such petroleum is so kept.

This section shall not apply to any petroleum kept either for private use or for sale, provided the following conditions are complied with :

(1) That it is kept in separate glass, earthenware, or metal vessels, each of which contains not more than a pint, and is securely stopped :

(2) That the aggregate amount kept, supposing the whole contents of the vessels to be in bulk, does not exceed three gallons.

8.<sup>1</sup> The following bodies shall respectively be the local authority to grant licenses under this Act in the districts hereinafter mentioned ; (that is to say),

(1) In the City of London, except as hereafter in this section mentioned, the Court of the Lord Mayor and aldermen of the said city :

(2) In the Metropolis (that is, in places for the time being within the jurisdiction of the Metropolitan Board of Works, under the Metropolis Management Act, 1855), except the City of London, and except as hereafter in this section mentioned, the Metropolitan Board of Works :

(3) In any borough in England or Ireland, except as hereafter in this section mentioned, the Mayor, aldermen, and burgesses acting by the council :

(4) In any place in England or Ireland, except as hereafter in this section mentioned within the jurisdiction of any trustees or improvement commissioners appointed under the provisions of any local or general Act of Parliament, and not being a borough, or comprising any part of a borough, the trustees or commissioners :

(5) In any place in England, except as hereafter in this section mentioned, within the jurisdiction of a local board constituted under the Local Government Act, 1858, and not being any of the districts before-mentioned, or comprising any part of any such district, the local board :

(6) In any burgh in Scotland, except as hereafter in this section mentioned, the town council :

(7) In any place in Scotland, except as hereafter in this section mentioned, within the jurisdiction of police commissioners, or trustees exercising the functions of police commissioners under any general or local Act, and not being a burgh, or comprising any part of a burgh, the police commissioners or trustees :

(8) In any harbour within the jurisdiction of a harbour authority, whether situate or not within the jurisdiction of any local authority before in this section mentioned, the harbour authority, to the exclusion of any other local authority :

(9) In any place in which there is no local authority, as before in this section defined, in England or Ireland, the justices in petty sessions assembled, and in Scotland, any two or more justices of the peace for the county, sitting as judges in the justice of peace court.

9. Licenses in pursuance of this Act shall be valid if signed by two or more of the persons constituting the local authority, or executed in any other way in which other licenses, if any, granted by such authority, are executed. Licenses may be granted for a limited time, and may be subject to renewal or not in such manner as the local authority think necessary.

There may be annexed to any such license such conditions as to the mode of storage, the nature and situation of the premises in which, and the nature of the goods with which petroleum, to which this Act applies, is to be stored, the facilities for the testing of such petroleum from time to time, the mode of carrying such petroleum within the district of the licensing authority, and generally as to the safe-keeping of such petroleum as may seem expedient to the local authority.

Any licensee violating any of the conditions of his license shall be deemed to be an unlicensed person. There may be charged in respect of each license granted in pursuance of this Act such sum, not exceeding five shillings,<sup>2</sup> as the local authority may think fit to charge.

10. If on any application for a license under this Act the local authority refuse the license,

<sup>1</sup> By the Local Government Acts the local authorities have been altered and may now be summarised as follows :—

In the City of London or in any borough—the Corporation.

In the County of London—the L.C.C.

In any harbour—the harbour authority, to the exclusion of any other local authority.

In any other place—in England, the District Council ; in Scotland, the County Council ; in Ireland, as in the Petroleum Act, 1871.

<sup>2</sup> In Scotland, by an Act of Sederunt, the fees are :—for lodging application for license or renewal, 5s. ; for license or renewal 3s. : for certificate of refusal, 3s.

Definition of local authority.

Mode of granting licenses.

In case of refusal of license the applicant may memorialise Secretary of State or Lord Lieutenant.

or grant the same only on conditions with which the applicant is dissatisfied, the local authority shall, if required by the applicant, deliver to him in writing, under the hand or hands of one or more of the persons constituting the local authority, a certificate of the grounds on which they refused the license, or annexed conditions to the grant thereof.

The applicant, within ten days from the time of the delivery of the certificate, may transmit the same to a Secretary of State, if the application is for a license in England or Scotland,<sup>1</sup> and to the Lord Lieutenant if the application is for a license in Ireland, together with a memorial, praying that notwithstanding such refusal, the license may be granted, or that the conditions may not be imposed, or may be altered or modified in such manner and to such extent as may be set forth in such memorial.

It shall be lawful for the Secretary of State, or the Lord Lieutenant, if he think fit, on consideration of such memorial and certificate, and, if he think it necessary or desirable, after due inquiry and a report by such person as he may appoint for that purpose, to grant the license prayed for, either absolutely or with such conditions as he thinks fit, or to alter or modify the conditions imposed by the local authority; and the license so granted, or altered and modified as the case may be, when certified under the hand of a Secretary of State, or the Lord Lieutenant, shall be to all intents as valid as if granted by the local authority.

11. Any officer authorised by the local authority may purchase any petroleum from any dealer in it, or may, on producing a copy of his appointment, purporting to be certified by the clerk or some member of the local authority, or producing some other sufficient authority, require the dealer to show him every or any place, and all or any of the vessels in which any petroleum in his possession is kept, and to give him samples of such petroleum on payment of the value of such samples.

Testing of petroleum by officer of local authority.

When the officer has by either of the means aforesaid taken samples of petroleum, he may declare in writing to the dealer that he is about to test the same, or cause the same to be tested, in manner set forth in Schedule One to this Act, and it shall be lawful for him to test the same, or cause the same to be tested, at any convenient place at such reasonable time as he may appoint, and the dealer or any person appointed by him may be present at the testing, and if it appear to the officer or other person so testing that the petroleum from which such samples have been taken is petroleum to which this Act applies, such officer or other person may certify such fact, and the certificate so given shall be receivable as evidence in any proceedings that may be taken against a dealer in petroleum in pursuance of this Act; but it shall be lawful for a dealer proceeded against to give evidence in proof that such certificate is incorrect, and thereupon the court before which any such proceedings may be taken may, if such court think fit, appoint some person skilled in testing petroleum to examine the samples to which such certificate relates, and to declare whether such certificate is correct or incorrect.

Any expenses incurred in testing any petroleum of such dealer in pursuance of this section shall, if such dealer be convicted of keeping, sending, conveying, selling, or exposing for sale, petroleum in contravention of this Act, be deemed to be a portion of the costs of the proceedings against him, and shall be paid by him accordingly. In any other event such expenses shall be paid by the local authority out of any funds for the time being in their hands, and in case the local authority are the justices, out of the county rate.

12. Any dealer who refuses to show to any officer authorised by the local authority every or any place, or all or any of the vessels in which petroleum in his possession is kept, or to give him such assistance as he may require for examining the same, or to give to such officer samples of such petroleum on payment of the value of such samples, or who wilfully obstructs the local authority, or any officer of the local authority, in the execution of this Act, shall incur a penalty not exceeding twenty pounds.

Penalty for refusing information and obstructing officer.

13. Where any court of summary jurisdiction is satisfied by information on oath that there is reasonable ground to believe that any petroleum to which this Act applies is being kept, sent, conveyed, or exposed for sale, within the jurisdiction of such court in contravention of this Act, at any place, whether a building or not, or in any ship or vehicle, such court shall grant a warrant, by virtue whereof it shall be lawful for any person named in such warrant to enter the place, ship, or vehicle named in such warrant, and every part thereof, and examine the same and search for petroleum therein, and take samples of any petroleum found therein, and if any petroleum to which the Act applies be found therein, which is kept, sent, conveyed, or exposed for sale in contravention of this Act, to seize and remove such petroleum, and the vessel containing the same, and to detain such petroleum and vessel until some court of summary jurisdiction has determined whether the same are or are not forfeited, the proceedings for which forfeiture shall be commenced forthwith after the seizure.

Search for petroleum. See 23 & 24 Vict. c. 139, s. 25.

Any person seizing any petroleum to which this Act applies in pursuance of this section shall not be liable to any suit for detaining the same, or for any loss or damage incurred in respect of such petroleum, otherwise than by any wilful act or neglect while the same is so detained.

<sup>1</sup> The Court of Appeal for Scotland is now the Secretary for Scotland.

If any petroleum to which this Act applies is seized in pursuance of this section in any ship or vehicle, the person seizing the same may use for purposes of the removal thereof, during twenty-four hours after the seizure, the said ship or vehicle, with the tackle, beasts, and accoutrements belonging thereto, and if he do so shall pay to the owner thereof a reasonable recompense for the use thereof, and the amount of such recompense shall, in case of dispute, be settled by the court of summary jurisdiction before whom proceedings for the forfeiture are taken, and may be recovered in like manner as penalties under this Act may be recovered.

Any person who, by himself or by anyone in his employ or acting by his direction or with his consent, refuses or fails to admit into any place occupied by or under the control of such person, any person demanding to enter in pursuance of this section, or in any way obstructs or prevents any person in or from making any such search, examination, or seizure, or taking any such samples as authorised by this section, shall be liable to pay a penalty not exceeding twenty pounds, and to forfeit all petroleum to which this Act applies which is found in his possession or under his control.

14. Her Majesty may from time to time make, revoke, and vary Orders in Council directing this Act or any part thereof to apply to any substance, and this Act, or the part thereof specified in the Order shall, during the continuance of the Order, apply to such substance, and shall be construed and have effect as if throughout it such substance had been included in the definition of petroleum to which this Act applies, subject to the following qualifications :

(1) The quantity of any substance to which this Act is directed by order in Council to apply, which may be kept without a license, shall be such quantity only as is specified in that behalf in such order, or if no such quantity is specified no quantity may be kept without a license :

(2) The label on the vessel containing such substance shall be such as may be specified in that behalf in the order.

15. In England and Ireland all offences and penalties under this Act, and all money and costs directed by this Act to be recovered as penalties, may be prosecuted and recovered in manner provided by the Summary Jurisdiction Acts.

In Scotland all offences and penalties under this Act, and all money and expenses by this Act directed to be recovered as penalties, shall, save as hereinafter provided, be prosecuted and recovered at the instance of the procurator fiscal or of any officer authorised in that behalf by the harbour authority or local authority under the provisions of the Summary Jurisdiction Acts before a court of summary jurisdiction, and all necessary powers and jurisdictions are hereby conferred on such court in Scotland.

Provided as follows :

1. A court of summary jurisdiction shall not impose a penalty exceeding fifty pounds, but any such court may impose that or any less penalty for any one offence, notwithstanding the offence involves a penalty of higher amount.

2. In Scotland any penalty exceeding fifty pounds shall be recovered and enforced in the same manner in which any penalty due to Her Majesty under any Act of Parliament may be recovered and enforced.

3. The " Court of Summary Jurisdiction," when hearing and determining an information or complaint, shall be constituted in some one of the following manners ; (that is to say),

(a) In England, either of two or more justices of the peace in petty sessions sitting at a place appointed for holding petty sessions, or one of the magistrates hereinafter mentioned, sitting alone or with others at some court or other place appointed for the administration of justice ; that is to say, the Lord Mayor, or any alderman of the City of London, a metropolitan police magistrate, a stipendiary magistrate, or some other officer or officers for the time being empowered by law to do alone or with others any act authorised to be done by more than one justice of the peace :

(b) In Scotland, of two or more justices of the peace sitting as judges in a justice of the peace court, or of one of the magistrates hereinafter mentioned sitting alone or with others at some court or other place appointed for the administration of justice ; that is to say, the sheriff of the county or his substitute, or the provost or other magistrate of a royal burgh, or some other officer or officers for the time being empowered by law to do alone or with others any act authorised to be done by more than one justice of the peace :

(c) In Ireland, within the police district of Dublin metropolis, of one of the divisional justices of the police district of Dublin metropolis, sitting at a police court within the said district ; and elsewhere, of a stipendiary magistrate, sitting alone or with others, or of two or more justices of the peace in petty sessions, sitting at a place appointed for holding petty sessions.

4. The description of any offence under this Act in the words of such Act shall be sufficient in law.

5. Any exception, exemption, proviso, excuse, or qualification, whether it does or not accompany the description of the offence in this Act, may be proved by the defendant, but need not be specified or negatived in the information, and if so specified or negatived no

Application of  
Act to other  
substances.

Summary pro-  
ceedings for  
offences,  
penalties, etc.

proof in relation to the matters so specified or negatived shall be required on the part of the informant or prosecutor.

6. No conviction or order made in pursuance of this Act shall be quashed for want of form or be removed by certiorari or otherwise, either at the instance of the Crown or of any private party, into any superior court. Moreover, no warrant of commitment shall be held void by reason of any defect therein, provided that there is a valid conviction to maintain such warrant, and it is alleged in the warrant that the party has been convicted.

7. All forfeitures may be sold or otherwise disposed of in such manner as the court may direct.

8. In Scotland all penalties imposed under the provisions of this Act by a Court of Summary Jurisdiction may be enforced in default of payment by imprisonment for a term not exceeding three calendar months; and all such penalties recovered and the proceeds of all forfeitures sold under this Act shall be paid to the clerk of the Court of Summary Jurisdiction, and by him accounted for and paid to the persons and for the purposes under stated; (that is to say),

(a) To the Queen's and Lord Treasurer's Remembrancer, on behalf of Her Majesty, when the Court is the Sheriff's Court:

(b) To the collector of county rates in aid of the general county assessment, when the Court is the Justice of the Peace Court:

(c) To the treasurer of the burgh in aid of the funds of the burgh when the Court is a Burgh Court.

9. In Ireland all penalties recovered under the provisions of this Act shall be applied according to the Fines (Ireland) Act, 1851, or any Act amending the same.

16. All powers given by this Act shall be deemed to be in addition to and not in derogation of any other powers conferred on any local or harbour authority by Act of Parliament, law, or custom, and every local authority and harbour authority may exercise such other powers in the same manner as if this Act had not passed; and nothing in this Act contained shall be deemed to exempt any person from any penalty to which he could otherwise be subject in respect of a nuisance.

Reservation of previous powers with respect to inflammable substances.

17. The Acts mentioned in Schedule Two to this Act are hereby repealed to the extent in that schedule mentioned.

Repeal of Acts.

Provided that such repeal shall not affect any Order in Council made, or any license granted, under any Act hereby repealed, or any liability or penalty incurred in respect of any offence committed before the passing of this Act, or any remedy or proceeding for enforcing such liability or penalty, and every such order, so far as relates to the matters provided for by this Act, and every such license, shall have effect as if it had been made or granted under this Act.

18. This Act shall continue in force until the first day of October, One thousand eight hundred and seventy-two, and no longer.

Duration of Act.

In 1879 a short Act was passed to legalise the Abel system of testing, and to substitute a test standard of 73° F. for the standard 100° F., the new system of testing being found to afford a lower flashing-point, with a given sample of oil, to an extent corresponding with that difference in temperature. This Act, which also provided for the continuance of the previous Act, is given in full, with the exception of the schedules prescribing the mode of testing, and specifying the portion of the Act of 1871 repealed. The schedule describing the mode of testing is given on pp. 769-774, vol. iii.

#### CHAP. 47.

An Act to continue and amend the Petroleum Act, 1871.

[11th August 1879.]

A.D. 1879.

BE it enacted by the Queen's most Excellent Majesty, by and with the advice and consent of the Lords Spiritual and Temporal, and Commons, in this present Parliament assembled, and by the authority of the same, as follows:—

1. This Act may be cited as the Petroleum Act, 1879.

This Act shall be construed as one with the Petroleum Act, 1871, and together with that Act may be cited as the Petroleum Acts, 1871 and 1879.

Short title and construction of Act.  
34 & 35 Vict. c. 105.

2. Whereas by the Petroleum Act, 1871, it is enacted that the term "petroleum to which this Act applies" means such of the petroleum defined by that Act as, when tested in manner set forth in Schedule One to that Act, gives off an inflammable vapour at a temperature of less than one hundred degrees of Fahrenheit's thermometer, and it is expedient to alter the said test: Be it therefore enacted that—

Alteration of test.  
34 & 35 Vict. c. 105.

In the Petroleum Act, 1871, the term "petroleum to which this Act applies" shall mean such of the petroleum defined by section three of that Act as, when tested in manner set forth

34 & 35 Vict. c. 105.

in Schedule One to this Act, gives off an inflammable vapour at a temperature of less than seventy-three degrees of Fahrenheit's thermometer.

Every reference in the Petroleum Act, 1871, to Schedule One to that Act shall be construed to refer to Schedule One to this Act.

3. A model of the apparatus for testing petroleum, as described in Schedule One to this Act, shall be deposited with the Board of Trade, and the Board of Trade shall, on payment of such fee, not exceeding five shillings, as they from time to time prescribe, cause to be compared with such model and verified every apparatus constructed in accordance with Schedule One to this Act which is submitted to them for the purpose, and if the same is found correct shall stamp the same with a mark approved of by the Board and notified in the *London Gazette*.

An apparatus for testing petroleum purporting to be stamped with the said mark shall, until the contrary is proved, be deemed to have been verified by the Board of Trade.

All fees under this section shall be paid into the Exchequer.

4. The Petroleum Act, 1871, shall continue in force until otherwise directed by Parliament.

5. This Act shall come into operation on the thirty-first day of December, one thousand eight hundred and seventy-nine, which day is in this Act referred to as the commencement of this Act.

6. The Petroleum Act, 1871, shall be repealed after the commencement of this Act to the extent in the third column of the Second Schedule to this Act mentioned.

Provided that any sample of petroleum taken before the commencement of this Act shall be tested in manner set forth in Schedule One to the Petroleum Act, 1871, and any offence committed before the commencement of this Act shall be prosecuted, and any investigation, legal proceeding, or remedy in relation to such offence, or to any act done before the commencement of this Act, shall be instituted, carried on, and have effect as if the provisions of this Act, other than those continuing the Petroleum Act, 1871, had not been passed.

After the Act of 1879 was passed, it was decided by the Court of Queen's Bench (*Coleman v. Goldsmith*, 43 J.P., p. 718, 8th November 1879) that a cart could not be licensed under the Act of 1871 as a "place" for keeping petroleum to which the Act applies, and that such petroleum could not be hawked in a cart otherwise than in pursuance of a license under the Act. Accordingly, the following Act was passed in 1881:—

#### CHAP. 67.

A.D. 1881.

An Act to regulate the hawking of Petroleum and other substances of a like nature.

[27th August 1881.]

BE it enacted by the Queen's most Excellent Majesty, by and with the advice and consent of the Lords Spiritual and Temporal, and Commons, in this present Parliament assembled, and by the authority of the same, as follows:

1. Any person who is licensed in pursuance of the Petroleum Act, 1871, to keep petroleum to which that Act applies may, subject to the enactments for the time being in force with respect to hawkers and pedlars, hawk such petroleum by himself or his servants.

2. With respect to the hawking of petroleum to which the Petroleum Act, 1871, applies, the following regulations shall be observed:

(1) The amount of petroleum conveyed at one time in any one carriage shall not exceed twenty gallons:

(2) The petroleum shall be conveyed in a closed vessel so constructed as to be free from leakage:

(3) The carriage in which the vessels containing the petroleum are conveyed shall be so ventilated as to prevent any evaporation from the petroleum mixing with the air in or about the carriage in such proportion as to produce an explosive mixture:

(4) Any fire or light or any article of an explosive or highly inflammable nature shall not be brought into or dangerously near to the carriage in which the vessels containing the petroleum are conveyed:

(5) The carriage in which the vessels containing the petroleum are conveyed shall be so constructed or fitted that the petroleum cannot escape therefrom in the form of liquid, whether ignited or otherwise:

(6) Proper care shall be taken to prevent any petroleum escaping into any part of a house or building, or of the curtilage thereof, or into a drain or sewer:

(7) The petroleum shall be stored in some premises licensed for keeping of petroleum, and in accordance with the license for such premises both every night and also when the petroleum is not in the course of being hawked:

(8) All due precautions shall be taken for the prevention of accidents by fire or explosion, and for preventing unauthorised persons having access to the vessels containing the petroleum,

34 & 35 Vict.  
c. 105.

Verification of  
test apparatus.

Continuance of  
34 & 35 Vict.  
c. 105.

Commencement  
of Act.

Repeal of part  
of 34 & 35 Vict.  
c. 105.

34 & 35 Vict.  
c. 105.

34 & 35 Vict.  
c. 105.

Power to hawk  
petroleum.  
34 & 35 Vict.  
c. 105.

Regulations for  
hawking  
petroleum.

and every person concerned in hawking the petroleum shall abstain from any act whatever which tends to cause fire or explosion, and is not reasonably necessary for the purpose of such hawking :

(9) No article or substance of an explosive or inflammable character other than petroleum, nor any article liable to cause or communicate fire or explosion, shall be in the carriage while such carriage is being used for the purpose of hawking petroleum :

In the event of any contravention of this section with reference to any petroleum, the petroleum, together with the vessels containing and the carriage conveying the same, shall be liable to be forfeited, and in addition thereto the licensee by whom or by whose servants the petroleum was being hawked shall be liable on summary conviction to a penalty not exceeding twenty pounds.

Provided that—

(1) Where some servant of the licensee or other person has in fact committed the offence such servant or other person shall be liable to the same penalty as if he were the licensee :

(2) Where the licensee is charged with a contravention of this section, he shall be entitled upon information duly laid by him to have any other person whom he charges as the actual offender brought before the court at the time appointed for hearing the charge, and if the licensee proves to the satisfaction of the court that he had used due diligence to enforce the execution of this section, and that the said other person had committed the offence in question without his knowledge, consent, or connivance, the said other person shall be summarily convicted of such offence, and the licensee shall be exempt from any penalty.

Any petroleum other than that to which the Petroleum Act, 1871, applies while in any carriage used for the hawking of petroleum to which the Petroleum Act, 1871, applies, shall for the purposes of this section be deemed to be petroleum to which the Petroleum Act, 1871, applies.

3. Any conditions annexed to a license granted in pursuance of the Petroleum Act, 1871, either before or after the passing of this Act, shall, so far as they are inconsistent with this Act, be void, but save as aforesaid nothing in this Act shall affect the application to a licensee of the provisions of the Petroleum Act, 1871, or of any license granted thereunder.

4. Where a constable or any officer authorised by the local authority has reasonable cause to believe that a contravention of this Act is being committed in relation to any petroleum, he may seize and detain such petroleum and the vessels and carriage containing the same, until some court of summary jurisdiction has determined whether there was or not a contravention of this Act, and section thirteen of the Petroleum Act, 1871, shall apply to such constable and officer as if he were the person named in the warrant mentioned in that section, and as if the seizure were a seizure in pursuance of that section.

5. Nothing in this Act contained shall extend to authorise the hawking of petroleum within the limits of any municipal borough in which, by any lawful authority, such hawking shall have been or may hereafter be forbidden.

6. For the purposes of this Act—

The expression "carriage" includes any carriage, wagon, cart, truck, vehicle, or other means of conveyance by land, in whatever manner the same may be drawn or propelled ; and

A person shall be deemed for the purposes of this Act to hawk petroleum if by himself or his servants he goes about carrying petroleum to sell, whether going from town to town or to other men's houses, or selling it in the streets of the place of his residence or otherwise, and whether with or without any horse or other beast bearing or drawing burden.

7. This Act may be cited as the Petroleum (Hawkers) Act, 1881.

This Act shall be construed as one with the Petroleum Acts, 1871 and 1879, and together with those Acts may be cited as the Petroleum Acts, 1871 to 1881.

After the passing of the Petroleum Act, 1879, the following memorandum, with drawings of the testing instrument, was issued by the Standards Office of the Board of Trade, this department being empowered to standardise the instruments to be placed in the hands of the inspectors appointed under the Act :—

#### PETROLEUM ACT, 1879.

##### REGULATIONS AS TO CONSTRUCTION AND VERIFICATION OF APPARATUS FOR TESTING PETROLEUM.

###### *Form of Apparatus.*

1. Every apparatus should be a copy, in form as well as in materials, of the model deposited with this Board. The form and dimensions of such model are shown on the accompanying diagrams.

Modification of conditions of license under 34 & 35 Vict. c. 105.

Power of constable as to prevention of offences.

Saving of rights of municipal boroughs.

Definitions.

Short title and construction of Act. 34 & 35 Vict. c. 105. 42 & 43 Vict. c. 47.

2. No greater deviation than two one-hundredths (0.02) of an inch should be made in the dimensions of the slide and the square holes on the cover of the oil cup. In other parts of the apparatus a deviation of one-tenth of an inch will be allowed.

*Thermometers.*

3. Thermometers should be carefully graduated, as shown in plate [see fig. 225].

*Name-plate on certain Apparatus.*

4. Apparatus required for the use of any Local Authority under the Petroleum Acts, should have the name of such Local Authority engraved on the front of the apparatus.

*Delivery of Apparatus.*

5. Apparatus should be delivered at this Office between 10 a.m. and 1 p.m. A written application or request should be sent with the apparatus, and when its comparison is completed, due notice will be sent to the applicant.

Each apparatus should be packed in a deal or mahogany box.

*Fee of Verification.*

6. On the verification of each apparatus a fee of five shillings will be charged.

*Mark of Verification.*

7. The mark of verification approved by the Board of Trade and notified in the *London Gazette*, is of the following design:—



*Pendulum.*

8. A mode of the lead line or pendulum used with this apparatus may be seen at this Office.

BOARD OF TRADE,  
STANDARDS OFFICE,  
7 OLD PALACE YARD, WESTMINSTER,  
1st January 1880.

The keeping on private premises of petroleum spirit for use in motor cars is subject to the following regulations:—

STATUTORY RULES AND ORDERS, 1907.

No. 614.

**LOCOMOTIVE.**

**Petroleum.**

REGULATIONS DATED JULY 31, 1907, MADE BY THE SECRETARY OF STATE UNDER SECTION 5 OF THE LOCOMOTIVES ON HIGHWAYS ACT, 1896, AS TO THE KEEPING AND USE OF PETROLEUM FOR THE PURPOSES OF LIGHT LOCOMOTIVES.

Locomotives on Highways Act, 1896 (59 & 60 Vict. c. 36, s. 5).

*In promulgating the following Regulations relating to the keeping, conveyance, and use of petroleum in connection with light locomotives, the Secretary of State for the Home Department desires to direct public attention to the dangers that may arise from the careless use of the more volatile descriptions of petroleum, commonly known as petroleum spirit. Not only is the vapour*



*therefrom, which is given off at ordinary temperatures, capable of being easily ignited, but it is also capable, when mixed with air, of forming an explosive atmosphere. It is, therefore, necessary, in dealing with and handling the spirit, to take strict precautions by the employment of thoroughly sound and properly closed vessels, and by avoiding the use of naked lights in dangerous proximity, to prevent leakage of the spirit and the contact of any form of artificial light with the highly inflammable vapour which it is always evolving.*

## REGULATIONS.

By virtue of the powers conferred on me by the Fifth Section of the Locomotives on Highways Act, 1896, I hereby make the following Regulations for the keeping and use of petroleum for the purposes of light locomotives.<sup>1</sup>

In these Regulations the expression "petroleum spirit" shall mean the petroleum to which the Petroleum Acts, 1871 and 1879, apply, provided that when any petroleum other than that to which the said Petroleum Acts apply, is on or in any light locomotive, or is being conveyed or kept in any place on or in which there is also present any petroleum spirit as above defined, the whole of such petroleum shall be deemed to be petroleum spirit.

In these Regulations the expression "storehouse" shall mean any room, building, coach-house, lean-to, or other place in which petroleum spirit for the purposes of light locomotives is kept in pursuance of these Regulations and shall include an open-air place of storage, when and so long as due precautions for the prevention of unauthorised persons having access to the petroleum spirit are taken in pursuance of No. 13 of these Regulations.

1. The following shall be exempt from license under the Petroleum Act, 1871, namely:—

- (a) Petroleum spirit which is kept for the purpose of, or is being used on, light locomotives when kept or used in conformity with these Regulations.
- (b) Petroleum spirit which is kept for the purpose of, or is being used on, light locomotives by, or by authority of, one of His Majesty's Principal Secretaries of State, the Admiralty, or other department of the Government.

2. These Regulations shall apply to petroleum spirit which is kept for the purpose of, or is being used on, light locomotives, and for which (save as hereinafter provided) no license has been granted by the Local Authority under the Petroleum Act, 1871, and shall not apply to petroleum spirit which is kept for sale, or partly for sale and partly in use on light locomotives, and which must be kept in accordance with the provisions of the Petroleum Acts as heretofore, except that Regulations 13 and 14 shall apply to petroleum spirit which is kept partly for sale and partly for use on light locomotives.

These Regulations shall not apply to the keeping or use of petroleum spirit by or under the control of any Government Department. Such keeping or use may be the subject of Regulations to be made by the Department concerned.

3. Where for any special reason a person keeping petroleum spirit for the purpose of light locomotives applies for a license under the Petroleum Act, 1871, and the Local Authority see fit to grant such license, such petroleum spirit shall be subject only to Regulations 8 to 15 and the conditions of such license, in so far as the said conditions are not contrary to the said Regulations 8 to 15.

4. Where a storehouse forms part of, or is attached to, another building, and where the intervening floor or partition is of an unsubstantial or highly inflammable character, or has an opening therein, the whole of such building shall be deemed to be the storehouse, and no portion of such storehouse shall be used as a dwelling or as a place where persons assemble. A storehouse shall have a separate entrance from the open air distinct from that of any dwelling or building in which persons assemble.

5. The amount of petroleum spirit to be kept in any one storehouse, whether or not upon light locomotives, shall not exceed 60 gallons at any one time.

6. Where two or more storehouses are in the same occupation and are situated within 20 feet of one another, they shall for the purposes of these Regulations be deemed to be one and the same storehouse, and the maximum amount of petroleum spirit prescribed in the foregoing Regulation shall be the maximum to be kept in all such storehouses taken together. Where two or more storehouses in the same occupation are distant more than 20 feet from one another, the maximum amount shall apply to each storehouse.

7. Any person who keeps petroleum spirit in a storehouse which is situated within 20 feet of any other building whether or not in his occupation, or of any timber stack or other inflammable goods not owned by him, shall give notice to the local authority under the Petroleum Acts for the district in which he is keeping such petroleum spirit, that he is so keeping

<sup>1</sup> Under the Seventh Section of the Act, a breach of these Regulations may, on summary conviction, be punished by a fine not exceeding ten pounds.

petroleum spirit, and shall renew such notice in the month of January in each year during the continuance of such keeping, and shall permit any duly authorised officer of the local authority to inspect such petroleum spirit at any reasonable time. This Regulation shall not apply to petroleum spirit kept in a tank forming part of a light locomotive.

8. Every storehouse shall be thoroughly ventilated.

9. Petroleum spirit shall not be kept, used, or conveyed except in metal vessels so substantially constructed as not to be liable, except under circumstances of gross negligence or extraordinary accident, to be broken or become defective or insecure. Every such vessel shall be so constructed and maintained that no leakage, whether of liquid or vapour, can take place therefrom.

10. Every such vessel, not forming part of a light locomotive, when used for conveying or keeping petroleum spirit shall bear the words "petroleum spirit highly inflammable" conspicuously and indelibly stamped or marked thereon, or on a metallic or enamelled label attached thereto, and shall be of a capacity not exceeding two gallons.

Provided that this limitation of capacity shall not apply in any place of storage which is licensed under the Petroleum Act, 1871, unless such limitation is required by the conditions of the license.

11. Before repairs are done to any such vessel, that vessel shall, as far as practicable, be cleaned by the removal of all petroleum spirit and of all dangerous vapours derived from the same.

12. The filling or replenishing of a vessel with petroleum spirit shall not be carried on nor shall the contents of any such vessel be exposed in the presence of fire or artificial light, except a light of such construction, position or character, as not to be liable to ignite any inflammable vapour arising from such spirit, and no fire or artificial light capable of igniting inflammable vapour shall be brought within dangerous proximity of the place where any vessel containing petroleum spirit is being kept.

13. In the case of all petroleum spirit kept or conveyed for the purpose of, or in connection with, any light locomotive, (a) all due precautions shall be taken for the prevention of accidents by fire or explosion, and for the prevention of unauthorised persons having access to any petroleum spirit kept or conveyed, and to the vessels containing or intended to contain, or having actually contained, the same; and (b) every person managing, or employed on, or in connection with, any light locomotive shall abstain from every act whatever which tends to cause fire or explosion, and which is not reasonably necessary, and shall prevent any other person from committing such act.

14. In the storehouse or in any place where a light locomotive is kept or is present, petroleum spirit shall not be used for the purpose of cleaning or lighting, or as a solvent or for any purpose other than as fuel for the engine of a light locomotive.

Provided that where due precaution is taken to prevent petroleum spirit from escaping into a sewer or drain and provision made for disposing safely of any surplus petroleum spirit and where no fire or naked light is present, quantities not exceeding one gill may be used for the cleaning of a light locomotive at a safe distance from any building, place of storage of inflammable goods, or much frequented highway, or for the repair of tyres, under suitable precautions.

This Regulation shall apply to premises on which petroleum spirit is kept for the purpose of, or is being used on, light locomotives, whether such premises are licensed or not, unless the Local Authority see fit, in the case of licensed premises to grant an exemption by a special term of the license.

15. Petroleum shall not be allowed to escape into any inlet or drain communicating with a sewer.

16. These Regulations shall come into operation on the 15th August 1907, from which date all previous Regulations made under the Fifth Section of the said Act are hereby repealed.

H. J. GLADSTONE,  
One of His Majesty's Principal  
Secretaries of State.

WHITEHALL,  
31st July 1907.

NOTE.—From the above Regulations it will be seen that there are two methods in which petroleum spirit required for use in motor cars may be kept. The first of these will be the usual method, namely, to keep in accordance with these Regulations; but where a person finds that for some special reason he cannot observe one of the Regulations, 4, 5, or 6, he may resort to the second method, namely, to apply to the Local Authority for a license. In such cases the place will be examined by the Local Authority Officer, who will advise the Local Authority as to its suitability for license. Where a license has been granted Regulations 4 to 7 no longer apply.

In no case is petroleum spirit kept wholly or partly for sale exempt from the necessity of a license.

## STATUTORY RULES AND ORDERS, 1919.

No. 780.

**LOCOMOTIVE.****Petroleum.**

REGULATION, DATED JUNE 21, 1919, MADE BY THE SECRETARY OF STATE, AMENDING REGULATIONS UNDER SECTION 5 OF THE LOCOMOTIVES ON HIGHWAYS ACT, 1896 (59 & 60 VICT., C. 36), AS TO THE KEEPING OF PETROLEUM FOR THE PURPOSES OF LIGHT LOCOMOTIVES.

Notwithstanding anything in No. 10 of the Regulations dated 31st July 1907, petroleum spirit may be kept for the purposes of light locomotives in iron or steel drums or barrels of a capacity not exceeding 50 gallons, provided the following conditions are observed:—

- (a) The storehouse must be situated at a distance of at least 20 feet from any other building or any highway or public footpath.
- (b) Provision must be made by excavation or by the erection of retaining walls to prevent outflow of the spirit in the event of fire if such outflow would be likely to endanger life or cause damage to the property of others.
- (c) Notice shall be given to the Local Authority, and the duly authorised officer of such Authority shall be allowed to inspect the spirit in the same manner as is provided in No. 7 of the said Regulations.

This Regulation shall remain in force until 31st December 1923, unless sooner revoked.

EDWARD SHORTT,  
*One of His Majesty's Principal  
Secretaries of State.*

WHITEHALL,  
21st June 1919.

**MUNICIPAL REGULATIONS.**

The London County Council is the Local Authority under the Petroleum Acts for the Metropolis, outside of the area over which the Corporation of the City of London has jurisdiction. A report on the industries carried on in London, in which "petroleum" (as defined in the Acts of 1871 to 1881) is employed under license, was drawn up for the Council in 1890 by Mr. Alfred Spencer, Chief Officer of the Public Control Department, and is here appended, together with copies of the forms of licenses issued:—

**LONDON COUNTY COUNCIL.**

Report as to licensed premises in the County of London, upon which petroleum, under the Acts, is used in trade or manufacture.

Presented to the Sanitary and Special Purposes Committee, 14th November 1890.

**PETROLEUM ACTS.**

In accordance with the instructions of the Committee at their meeting on the 31st October, that I should prepare a report submitting a list of the businesses carried on in London in which petroleum spirit is used in manufacturing processes or otherwise, I have to report as follows:—

The following is a list of the businesses in which petroleum is so used, carried on in the county of London under the licenses of the Council:—

- Dry Cleaners (21 licensed premises).
- Helmet Manufacturers (5 licensed premises).
- Tennis Shoe Manufacturers (4 licensed premises).
- Indiarubber Manufacturers (12 licensed premises).
- Waterproof Garment Manufacturers (41 licensed premises).
- Glass Silverers (14 licensed premises).
- Paint Manufacturers (6 licensed premises).
- Glove Cleaners (41 licensed premises).

The licenses granted in respect of all these businesses have special conditions attached, with a view to safety, and in some cases these conditions appear to be fully adequate, as they probably reduce the danger in the particular processes carried on to the minimum. In some of the businesses, however, it may be desirable to make some addition to the existing precautions.

Whenever mineral spirit or its inflammable vapour is liable to be present in workrooms in dangerous quantity, the following precautions should, wherever possible, be adopted—

- (a) The workroom should be a detached fireproof building on a level with the ground.
- (b) The workroom should be well ventilated, both at the ground and ceiling levels.
- (c) The workroom should be provided with doors opening outwards, in order to facilitate the escape of the workpeople in case of accident.
- (d) The process in which mineral spirit is used should be carried on in closed vessels, and where that is not possible, the exposure of spirit should be reduced to a minimum, in order to lessen the formation of inflammable vapour.
- (e) Such artificial light as would ignite inflammable vapour should be wholly excluded from workrooms in which mineral spirit is used. The only artificial light allowed should be incandescent electric light, or a form of gas-light where the light is so enclosed as not to be in contact with the air of the workroom.

Taking the businesses in the order in which they appear in the above list, the first to be dealt with is—

1. **Dry Cleaners.**—In this business, mineral spirit is used, generally in large quantity, in the cleaning of dress material and other substances. The spirit is kept in specially constructed stores, and the cleaning takes place in specially constructed buildings.

Practically all the conditions for safety already indicated are insisted on by the conditions attached to licenses granted to dry cleaners in London.

Formerly there were numerous accidents in connection with this business, but for the past few years, since the adoption of the indicated precautions, only one fire has occurred in London; and fortunately, on account of the isolation of the building and the precautions imposed by the license, no fatality or even personal injury resulted, nor did the fire extend beyond the actual building in which it broke out. It may be mentioned as an instance of the value of precautions in businesses of this nature, that on one of the dry cleaner's premises, before the present stringent conditions were insisted upon, the cleaning-room was burnt out five times in six years; but that since the adoption of these precautions some seven years since, no fire has occurred on the premises.

2. **Helmet Manufacturers.**—In this business, a quantity of petroleum spirit, in no case exceeding 45 gallons, is used for the purpose of dissolving indiarubber to form a solution used in cementing and waterproofing some forms of helmets. I do not consider the conditions attached to licenses for premises in which this business is carried on are sufficiently stringent. Difficulty was experienced in obtaining adequate arrangements for safety, both on account of the situation and construction of many of the premises. In every case, however, the petroleum spirit is kept, and the indiarubber solution is made, in a store which is as far as possible detached from the workrooms. The solution is used for cementing and waterproofing helmets, and in the room in which this is done, as well as in the place in which the helmets are afterwards dried, a considerable amount of inflammable vapour is given off. The vapour is to some extent carried off by ventilation, but at present artificial light is used in some of the workrooms; and, looking to the recent fatal accident at a helmet manufacturer's in Cloth Fair, I think that such a method of lighting should no longer be permitted. No special provision is made upon any of the licensed helmet makers' premises for the escape of workpeople in case of accident, and the Committee may consider it desirable in future to license only premises where adequate means of escape have been provided. I may, however, point out that no serious fire, or any fire involving loss of life, has occurred in recent years upon any of the licensed premises. The recent fatal fire on Messrs. Rowley & Brock's premises (which are in the city and under the jurisdiction of the Corporation of London) probably arose from the very grossest carelessness and the neglect of the most elementary precautions. An uncorked can containing a solution of naphtha and indiarubber was placed in the drying stove, and on the door of the stove being opened a volume of the vapour escaped and ignited.

Although no accident can be traced to the use of naked lights in workrooms where solution is used, it would undoubtedly reduce the danger if the Council insisted on the abolition of such lights and the substitution of the incandescent electric light or some perfectly safe form of gas lighting. In every case where a drying stove by fire heat is used, such stoves should unquestionably be separated from the workrooms and ventilated into the external air, or in other words, it should be a distinct fire risk.

3. **Tennis Shoe Makers.**—In this trade an indiarubber solution is used for cementing indiarubber soles to the uppers. The danger and the conditions are very similar to those in the case of helmet makers, and whatever the Committee decide as to the one trade should be applied to the other.

4. **Indiarubber Manufacturers.**—In this trade, indiarubber in bulk is dissolved in mineral

spirit, and then mixed with other ingredients to form a plastic substance, which is worked up into various forms of indiarubber goods.

I think the arrangements for the storage of the naphtha and for dissolving the rubber are probably adequate at all the premises under the Council's license. After being taken out of the vessels in which it is dissolved, the indiarubber is of the consistency of dough, and it is so termed by the trade. It subsequently passes through a variety of machines, for manufacture into different articles, and during these processes some inflammable vapour is given off, but probably not in sufficient quantities to be liable to ignition. I recommend the Committee to in future attach a condition excluding fires and unsafe forms of artificial lighting, not only in the stores and mixing rooms as at present, but also in any workroom where there is a liability to the presence of inflammable vapour.

**5. Waterproof Garment Makers.**—This business is sometimes conducted on a very large scale in very large buildings, and in others on a small scale, and sometimes in dwellings. No matter how many or how few hands are at work, each of them requires a small quantity of solution and a small quantity of spirit. This is used for cementing the seams of the garments to be manufactured, and as there is but a small amount of vapour given off in the operations of each work-person, it is only where a large number of workpeople are employed in one room that there is a liability to the formation of a large amount of inflammable vapour. The two points for the consideration of the Committee appear to be—

(1) Whether fires and exposed artificial light should not be prohibited in all such work-rooms.

(2) Whether facilities for escape, in case of accident, should not be insisted upon, wherever a considerable number of hands are employed in one building.

By requiring both the solution and the naphtha to be used from suitable vessels, and by regulating the storage of the naphtha and the mixing of the solution, the Council has reduced the danger in these places; but the other points indicated are matters for serious consideration. I may point out, however, that there might be great difficulty in the case of the smaller makers, and of the workpeople who carry on this business in their own homes, in providing a special artificial light, or special means of heating the rooms.

**6. Glass Silverers.**—In this business mineral spirit is used in the manufacture of the paint which covers the back of silvered glass. The spirit is usually kept and the paint mixed in the basement of the building where the business is carried on, and it has been impracticable to obtain in such cases external places for the storage and the mixing. There is probably little danger in the process of applying the paint to the glass; and the point for the consideration of the Committee appears to be whether in future the storage and mixing should be allowed in the building in which the workrooms are situated.

**7. Glove Cleaning.**—In this business only small quantities of mineral spirit are used, and in a large number of cases the trade is so small that it can be carried on under the exemption contained in section 7 of the Petroleum Act, 1871, which permits three gallons of spirit to be kept without a license, provided it is kept in stoppered bottles which contain not more than 1 pint. The practice in London is that, where only one of these bottles is open at a time, no license is necessary, but whenever any larger quantity than 1 pint is opened for use at one time, a license is requisite. Although the quantity of petroleum used in glove cleaning is small, there is a considerable escape of inflammable vapour, and consequent danger. Upon every premises licensed by the Council, glove cleaning is required to be carried on in buildings either detached or external to the house or shop, and the presence of a fire or artificial light is forbidden. It is probably unnecessary to add to the restriction already imposed on this business.

In addition to the foregoing, there are also a few other businesses in which petroleum spirit is used, and which are under the license of the Council, as follows:—

- One bone boiler.
- „ bedstead manufacturer.
- „ photographic chemical manufacturer.
- „ manufacturing chemist.
- „ brassfitter (asbestos packing).
- „ paraffin scale maker.
- „ electrician (four licenses).
- „ colour printing works.

I believe the conditions imposed in each of the above cases are adequate for safety.

The only remaining trade in which it is known that petroleum spirit is used, is that of toy balloon maker. Two premises upon which this trade is carried on are licensed, and at each 5 gallons may be kept. In both cases, the store is a sunk pit in the garden at rear of the dwelling, and this method is quite safe. The spirit is, however, taken in quantities not exceeding half a gallon, into a workroom in the upper part of the dwelling, where it is put into an open vessel, into which the indiarubber is dipped. No fire or light is allowed in this room, and the work is done with open windows, and it is probable that no further precaution can be adopted, except

to require that the work be done in outbuildings only. The licensees are, however, so poor that they are unable to provide these. These premises have been under license for some years, and the inspector reports that he has always found the business conducted with care.

## LONDON COUNTY COUNCIL.

### PUBLIC CONTROL DEPARTMENT.

#### *Petroleum Acts, 1871 to 1881.*

#### ABSTRACT OF THE REGULATIONS AS TO THE STORAGE, CONVEYANCE, AND HAWKING OF PETROLEUM IN THE COUNTY OF LONDON.

*This abstract has no legal validity, and is intended only for the information and guidance of the persons concerned. For further information reference should be made to the Petroleum Acts, 1871 and 1879, to the Petroleum (Hawkers') Act, 1881, the Petroleum Mixture Order, dated 7th May 1907, and to the Regulations of the Secretary of State, dated 31st July 1907, made under Section 5 of the Locomotives on Highways Act, 1896.*

### General.

#### Definitions.

1. Petroleum to which the Acts apply means any rock oil, Rangoon oil, Burma oil, oil made from Petroleum coal, schist, shale, peat, or other bituminous substance, and any products of Petroleum or any of the above-mentioned oils, which, when tested in the prescribed manner, give off an inflammable vapour at a temperature of less than 73 degrees of Fahrenheit's thermometer.

This definition includes benzine, benzol, benzoline, carburine, gasoline, motor spirit, naphtha, pentane, petrol; and these and similar substances are termed in this abstract "Petroleum Spirit."

The Acts also apply to any composition or mixture which contains Petroleum Spirit. Such compositions are termed "Petroleum Mixtures," and include india-rubber solution, some varnishes and quick-drying paints, etc.

The term "Petroleum" used in this abstract includes both Petroleum Spirit and Petroleum Mixtures.

(NOTE.—*Paraffin or Petroleum oils, such as are commonly used in domestic lamps, do not flash below 73 degrees F.*)

2. Where Petroleum is—

- (a) Kept at any place (except during the seven days next after importation); or
- (b) Conveyed; or
- (c) Sold or exposed for sale,

the vessel containing it shall have a label stating in conspicuous characters the description of the Petroleum and the name and address of the owner, sender or vendor, with the addition—

- (1) In the case of Petroleum Spirit of the words "highly inflammable."
- (2) In the case of Petroleum Mixture of the words "Petroleum Mixture giving off an inflammable heavy vapour." "Not to be exposed near a flame."

3. Petroleum can only be kept in pursuance of a license granted by the Council, except as follows:—

- (a) Not exceeding three gallons may be kept in separate glass, earthenware, or metal vessels, securely stopped, each of which must not contain more than one pint.
- (b) In the case of Petroleum Mixtures, solid or otherwise unsuitable to be measured by liquid measure, not exceeding thirty pounds may be kept in separate sealed packages or vessels each containing not more than one pound.
- (c) When it is kept or used for the purposes of light locomotives in accordance with the Regulations as to Petroleum made by the Secretary of State.

### Licenses.

4. Application to the Council for a license must be made upon the form provided for the purpose, which can be obtained by application in writing, addressed to the Chief Officer, Public Control Department, London County Council, 21 Northumberland Avenue, W.C.

5. Every application must be accompanied by a fee of 5s. in money, or, if sent through the post, by cheque or Postal Order payable to the order of the London County Council. The fee will be returned to the applicant if the license be not granted.

#### Applications.

#### Fees.

#### Labelling Vessels.

#### Keeping Petroleum.

6. Where the application is for a license to store 50 gallons or more there must also be sent **Plans.** a ground plan, drawn to the scale of one-eighth of an inch to a foot, and showing the places where it is proposed to keep and use petroleum, and also showing the buildings, etc., within 50 feet of such places. An elevation of the store should be included.

7. Every application must state—

- (a) The quantity of Petroleum which the applicant desires to keep ;  
 (b) The proposed place and method of storage ;  
 (c) Particulars of the processes (if any) in which the Petroleum is to be used.

Particulars in Application.

8. Petroleum should, whenever possible, be stored in one of the following methods—

- (a) In a strong metal tank sunk in the ground in concrete at a suitable place and covered with concrete ; the tank to have no openings but for necessary pipes. Where practicable the concrete over the tank should be raised a few inches above the surrounding ground level so that flood water cannot lie over the manhole or pipe connections.  
 (b) In a concrete, stone, brick, or iron store (partially sunk into the ground where possible), the lower part so constructed as to form a well capable of receiving, in case of accident, all the Petroleum contained in the store. The store should have ample floor area so as to avoid making the well too deep. The store must be ventilated sufficiently, at high and low levels, to prevent the accumulation therein of inflammable vapour, and all ventilating openings must be protected by strong wire gauze, mesh about 800 to the square inch, or 28 to the lineal inch. (See diagram.)

Mode of Storage.

Both sunk tanks and above-ground stores should be placed in positions in the open air at safe distances from buildings or inflammable materials.

The Council also grants licenses to keep quantities not exceeding 10 gallons of Petroleum Spirit in yards or other suitable situations, on condition that a place of storage having a superficial area measuring at least 5 feet by 5 feet is provided, and is exclusively appropriated to the purpose, and that such place of storage is not within any inhabited building.

*In cases where the foregoing methods of storage cannot be adopted, the Council may grant licenses under special conditions, provided the means of storage and precautions for safety proposed are considered satisfactory.*

9. The Petroleum Spirit in the tanks of motor cars standing in garages will be included in the terms of the petroleum license, and it is desirable that garages should be constructed of fire-resisting materials and be provided with impermeable floors. Garages should be well ventilated, and any artificial lighting and heating should be afforded by means that will not ignite inflammable vapour. A plentiful supply of sand should also be kept in convenient positions.

Notes as to Garages.

One of the safest methods of heating garages is by means of hot water, steam, or warm air conducted by pipes or ducts from a stove placed outside the garage in a position where there is no risk of any inflammable vapour being ignited.

Only safe lights should be used in inspection pits on account of the tendency of the heavy petroleum vapour to collect in such pits. No connections for portable electric lamps should be fitted in inspection pits.

Inspection pits should not be provided with a drain unless such drain passes to an approved petroleum interceptor. (See below.)

*Before installing any system or adopting any method of heating garages, licensees and applicants for licenses should communicate with the Chief Officer of the Public Control Department.*

*Applicants and licensees should note that all new buildings or structural alterations must be in compliance with the provisions of the London Building Acts.*

*Care should be taken not to carry out any works in connection with the storage of petroleum until it has been ascertained whether or not the Council will grant a license ; or, if petroleum spirit is to be kept under the Secretary of State's Regulations as to petroleum for light locomotives, that the proposed arrangements comply with the requirements of those Regulations.*

10. The following are the usual general conditions contained in Petroleum licenses granted by the Council.

General Conditions in Licenses.

That the total quantity of Petroleum (including mixtures of Petroleum with other substances) kept upon the premises, hereby licensed, do not at any time exceed

That Petroleum be kept only in

(Here follows description of the place of storage and the method of using the Petroleum.)

That Petroleum be not kept or used otherwise than as specified in this license.

That no substance other than Petroleum be deposited or kept in the place of storage above described, and that explosives, matches, or other inflammable or explosive substances be not in or near any store, workroom, or other place where Petroleum is kept or used.

That all Petroleum received upon the premises be at once taken to the place of

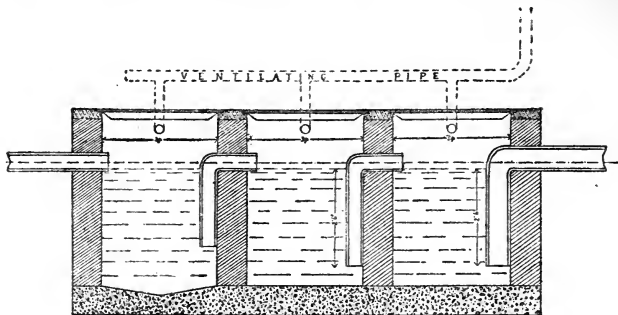

Longitudinal Section.

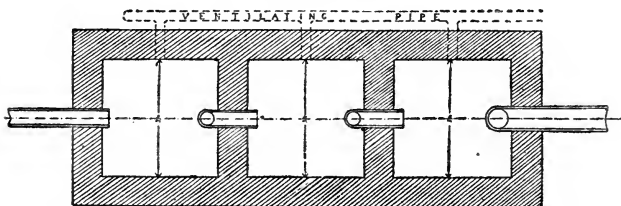

Sectional Plan.

Scale  $\frac{1}{4}$  inch to foot.

FIG. 358.—BRICK INTERCEPTING TANK FOR RETAINING PETROLEUM. THROUGH WHICH ALL SURFACE DRAINAGE MUST PASS BEFORE ENTERING THE SEWER.

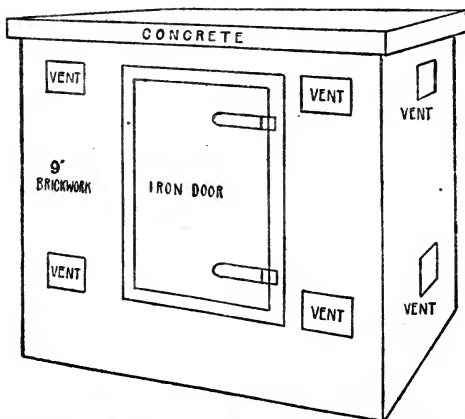

FIG. 359.—DIAGRAM OF PETROLEUM STORE. (See REGULATION 8 (b).) SHOWING SUITABLE POSITIONS FOR DOOR AND VENTILATING OPENINGS.



storage; and that Petroleum taken from the place of storage for delivery be at once removed from the premises.

That Petroleum be received on the licensed premises only between sunrise and sunset.

That due precautions be at all times taken for the prevention of accident from fire, and that fire or such artificial light as will ignite inflammable vapour be not within the store or within twenty feet of the openings thereof.

That buildings or workrooms in which Petroleum is kept or used be at all times thoroughly ventilated into the external atmosphere, and that sufficient sand to extinguish fire be kept in such buildings or workrooms.

That the licensee do take effectual precautions for preventing unauthorised persons, and all persons under the age of 15 years, from obtaining access to the place of storage, or to any Petroleum upon the premises.

That Petroleum be exclusively contained in strong metal vessels, and that such vessels be at all times securely closed except for the time absolutely necessary for the purposes of the business, and that every precaution be taken for preventing the leakage of Petroleum or the escape of inflammable vapour.

That Petroleum or any product or residue from Petroleum be not allowed to enter any inlet or drain communicating with a public sewer.

That the arrangements for the storage or use of Petroleum as approved by the Council and as seen by the Council's inspector last before the granting of the license, be in all respects kept and maintained, unless the consent of the Council is given in writing to any departure therefrom.

That every authorised officer of the Council be at all times allowed free access to the premises of the licensee, for the purpose of ascertaining if the above conditions are properly observed; and that the licensee do, by himself or his representatives, give any assistance for that purpose which such officer may require, and furnish samples of substances alleged to be Petroleum.

#### *Conveyance Conditions.*

(a) That Petroleum Spirit to which the Acts apply be carried in the County of London only in strong vessels, such vessels to be closed so as to prevent leakage or the escape of vapour, and labelled in the manner prescribed in Section 6 of the Petroleum Act of 1871.

(b) That a fire or such light as would ignite inflammable vapour or any article of an explosive or highly inflammable nature be not carried upon or brought into or dangerously near to any carriage in which Petroleum Spirit is being conveyed.

(c) That sufficient sand or other means satisfactory to the Council for extinguishing fire be carried on every vehicle in which Petroleum Spirit is being conveyed.

11. In all cases where Petroleum Spirit is used or handled to any considerable extent an intercepting chamber of approved pattern should be provided to prevent any spilled spirit from entering the drains. The discharge of Petroleum, including Petroleum Oil, into the sewers is prohibited by the Council's Order under Section 10 of its General Powers Act, 1894. Penalty for infringement, £20. (*See diagram of interceptor on p. 996.*)

Discharge into Sewers.

12. Licenses are granted for periods not exceeding one year, and prior to expiration application must be made for their renewal. Notice of the expiration, and a form of application for renewal, is sent to each licensee at the proper time.

Duration of License.

#### **Hawking Petroleum.**

13. Any person licensed to keep Petroleum Spirit may, subject to the enactments as to Hawkers and Pedlars, and to the regulations of the Petroleum (Hawkers') Act, 1881, hawk Petroleum by himself or his servants.

Hawking Petroleum.

#### **Petroleum Spirit for Use for Motor Cars.**

14. Petroleum Spirit for use for motor cars or motor cycles may be kept without a license if the restrictions laid down in the Regulations of the Secretary of State under the Locomotives on Highways Act are strictly observed.

Petroleum Spirit for Motor Cars.

Where these regulations cannot be observed, or where it is intended to sell spirit a license is necessary.

#### **Inspection.**

15. Any dealer who refuses to show any officer authorised by the Council every or any place or all or any of the vessels in which Petroleum or Petroleum Oil in his possession is kept, or to give him such assistance as he may require for examining the same, or to give to such

Refusing Information or Obstructing Officer.

officer samples of such Petroleum or Petroleum Oil on payment of the value of such samples, or who wilfully obstructs the Council, or any Officer of the Council, in the execution of this Act, incurs a penalty of not exceeding twenty pounds.

JAMES OLLIS,  
Chief Officer.

21 NORTHUMBERLAND AVENUE, W.C.

## LONDON COUNTY COUNCIL.

*Petroleum Acts, 1871 to 1881.*

### PETROLEUM LICENSE.

PURSUANT to the provisions of the Petroleum Acts, 1871 to 1881, the London County Council doth hereby, at the request of M \_\_\_\_\_ grant license to \_\_\_\_\_ for the period of twelve calendar months from the \_\_\_\_\_ to keep \_\_\_\_\_ gallons of petroleum to which the Acts apply, and as defined in the said Acts, on the premises situate at \_\_\_\_\_ in the parish of \_\_\_\_\_ and within the jurisdiction of the said Council, subject to the conditions following, that is to say—

1. That the Petroleum be kept only in a store substantially constructed entirely of concrete, stone, brick, or iron, and having a fireproof door which is to be kept locked at all times, except when Petroleum is being placed in or removed from the store; that such store be not within any building, or abutting against a dwelling-house; that the lower part of such store be so constructed as to form a tank capable of receiving and retaining, in case of accident, all the Petroleum contained in the store; that the store be ventilated sufficiently to prevent the accumulation therein of an inflammable vapour, and that all ventilating openings be protected with strong wire gauze.

2. That the place of storage aforesaid be in all respects kept and maintained in the same condition that it was in when inspected by an authorised officer of the Council last before the granting of this license.

3. That there be no fire, forge, furnace, or similar source of danger, or any storage of explosives within 20 feet, or of highly inflammable material within 10 feet, of such place of storage, unless separated therefrom by a wall or screen of sufficient strength and height to prevent the communication of fire.

4. That no substance other than Petroleum be deposited or kept in the place described in the first condition of this license.

5. That, unless otherwise specially provided for in the first condition of this license, all Petroleum kept upon the premises be exclusively contained in strong metal vessels, the openings to which are covered with fine wire gauze and fitted with screw caps, and with secure taps, so constructed and connected as to prevent leakage or the escape of vapour; and that such vessels and taps be kept in thoroughly good order.

6. That there be kept painted in conspicuous characters on every storage vessel containing Petroleum, the description of Petroleum, with the addition of the words "Highly inflammable."

7. That Petroleum be only conveyed to or from the licensed premises in closed vessels, so constructed as to be entirely free from leakage.

8. That no Petroleum be conveyed to or from the licensed premises in a vehicle in which gunpowder or other article likely to cause fire or explosion is also carried.

9. That Petroleum be only received in or supplied from the licensed premises between sunrise and sunset; and that no artificial light or fire, or article likely to cause fire, be at any time taken into or near the place of storage.

10. That the vessels containing Petroleum be only opened upon the licensed premises at or immediately adjoining the place of storage, and for the time necessary for drawing off the Petroleum, and that during such drawing off every reasonable precaution be adopted for preventing the escape of petroleum or the vapour therefrom.

11. That all Petroleum received upon the premises be at once taken to the place of storage; and that Petroleum taken from the place of storage for delivery or otherwise, be at once removed from the premises.

12. That the licensee do take effectual precautions for preventing unauthorised persons and all persons under the age of fifteen years from obtaining access to the place of storage.

13. That not less than a bushel of sand be kept with every vessel in which petroleum is stored, and that some portion of this be constantly kept immediately under the tap of the vessel.

14. That due precaution be at all times taken for the prevention of accident from fire.
15. That every authorised officer of the Council be at all times allowed free access to the premises of the licensee, for the purpose of ascertaining if the above conditions are properly observed ; and that the licensee do, by himself or his representatives, give any assistance for that purpose which such officer may require.

By Order of the Council,

*Clerk of the Council.*

Section 9 of the Petroleum Act, 1871, provides that "any licensee violating any of the conditions of his license shall be deemed to be an unlicensed person."

*This license is not transferable.*

LONDON COUNTY COUNCIL.

*Petroleum Acts, 1871 to 1881.*

PETROLEUM LICENSE.

PURSUANT to the provisions of the Petroleum Acts, 1871 to 1881, the London County Council doth hereby, at the request of M \_\_\_\_\_ grant license to \_\_\_\_\_ to keep \_\_\_\_\_ gallons of Petroleum to which the Acts apply, and as defined in the said Acts, on the premises situate at \_\_\_\_\_ in the parish of \_\_\_\_\_ and within the jurisdiction of the said Council, subject to the conditions following, that is to say—

(Special License.)  
Reg. No.

1. That the petroleum be kept only in \_\_\_\_\_
2. That the place of storage aforesaid be in all respects kept and maintained in the same condition that it was in when inspected by an authorised officer of the Council last before the granting of this license.
3. That there be no fire, forge, furnace, or similar source of danger, or any storage of explosives within \_\_\_\_\_ feet, or of highly inflammable material within \_\_\_\_\_ feet, of such place of storage, unless separated therefrom by a wall or screen of sufficient strength and height to prevent the communication of fire.
4. That no substance other than petroleum be deposited or kept in the place described in the first condition of this license.
5. That, unless otherwise specially provided for in the first condition of this license, all petroleum kept upon the premises be exclusively contained in strong metal vessels, the openings to which are covered with fine wire gauze and fitted with screw taps, and with secure taps, so constructed and connected as to prevent leakage or the escape of vapour ; and that such vessels and taps be kept in thoroughly good order.
6. That there be kept painted in conspicuous characters on every storage vessel containing petroleum, the description of petroleum with the addition of the words " Highly inflammable."
7. That petroleum be only conveyed to or from the licensed premises in closed vessels, so constructed as to be entirely free from leakage.
8. That no petroleum be conveyed to or from the licensed premises in a vehicle in which gunpowder or other article likely to cause fire or explosion is also carried.
9. That petroleum be only received in or supplied from the licensed premises between sunrise and sunset ; and that no artificial light or fire, or article likely to cause fire, be at any time taken into or near the place of storage.
10. That the vessels containing petroleum be only opened upon the licensed premises at or immediately adjoining the place of storage, and for the time necessary for drawing off the petroleum, and that during such drawing off every reasonable precaution be adopted for preventing the escape of petroleum or the vapour therefrom.
11. That all petroleum received upon the premises be at once taken to the place of storage ; and that petroleum taken from the place of storage for delivery or otherwise, be at once removed from the premises.
12. That the licensee do take effectual precautions for preventing unauthorised persons and all persons under the age of 15 years from obtaining access to the place of storage.
13. That not less than a bushel of sand be kept with every vessel in which petroleum is stored, and that some portion of this be constantly kept immediately under the tap of the vessel.
14. That due precaution be at all times taken for the prevention of accident from fire.

# 1000 REGULATIONS RELATING TO PETROLEUM AND ITS PRODUCTS.

15. That every authorised officer of the Council be at all times allowed free access to the premises of the licensee, for the purpose of ascertaining if the above conditions are properly observed; and that the licensee do, by himself or his representatives, give any assistance for that purpose which such Officer may require.

By Order of the Council,

*Clerk of the Council.*

Section 9 of the Petroleum Act, 1871, provides that "any licensee violating any of the conditions of his license shall be deemed to be an unlicensed person."

*This license is not transferable.*

## LONDON COUNTY COUNCIL.

*Petroleum Acts, 1871 to 1881.*

### PETROLEUM LICENSE.

PURSUANT to the provisions of the Petroleum Acts, 1871 to 1881, the London County Council doth hereby at the request of \_\_\_\_\_ grant license to \_\_\_\_\_ for the period of one year from the \_\_\_\_\_ to keep petroleum, to which the Acts apply, and as defined in the said Acts, on the premises \_\_\_\_\_ in the Metropolitan Borough of \_\_\_\_\_ and within the County of London, subject to the conditions following, that is to say—

That the total quantity of petroleum (including substances containing petroleum) kept upon the premises hereby licensed, do not at any time exceed \_\_\_\_\_

That such petroleum be kept only in the manner and at the places hereinafter specified, viz.—

That explosives, matches, or other inflammable or explosive substances be not in or near any store, workroom, or other place where petroleum is kept or used.

That petroleum be not kept or used in any part of the premises other than as specified in this license.

That due precautions be at all times taken for the prevention of accident from fire, and that fire or such artificial light as will ignite inflammable vapour be not within or nearer than feet of the openings of buildings, workrooms, or places where petroleum is kept or used.

That buildings or workrooms in which petroleum is kept or used be at all times thoroughly ventilated into the external atmosphere, and that sufficient sand be kept in such buildings or workrooms.

That the licensee do take effectual precautions for preventing unauthorised persons, and all persons under the age of 15 years, from obtaining access to the place of storage.

That vessels containing petroleum be only opened for the time absolutely necessary for the purposes of the business, and that every precaution be used for preventing the escape of inflammable vapour.

That petroleum or any product or residue from petroleum be not allowed to enter any inlet or drain communicating with a public sewer; and that every such inlet be provided with an intercepting chamber or trap so constructed as to effectually prevent the accidental discharge into a drain of petroleum or any product or residue therefrom.

That the arrangements for the storage or use of petroleum as approved by the Council and as seen by the Council's inspector last before the granting of this license, be in all respects kept and maintained, unless the consent of the Council is given in writing to any departure therefrom.

That every authorised officer of the Council be at all times allowed free access to the premises of the licensee, for the purpose of ascertaining if the above conditions are properly observed; and that the licensee do, by himself or his representatives, give any assistance for that purpose which such officer may require, and furnish samples of substances alleged to be petroleum.

By Order of the Council,

*Clerk of the Council.*

SPRING GARDENS, S.W.

Section 9 of the Petroleum Act, 1871, provides that "any licensee violating any of the conditions of his license shall be deemed to be an unlicensed person."

*This license is not transferable.*

(Special License.)

Reg. No.

LONDON COUNTY COUNCIL.

*Petroleum Acts, 1871 to 1881.*

PETROLEUM LICENSE.

Special License.

PURSUANT to the provisions of the Petroleum Acts, 1871 to 1881, the London County Council doth hereby grant license to \_\_\_\_\_ for the period of one year from the \_\_\_\_\_ to keep petroleum, to which the Acts apply, and as defined in the said Acts, on the premises \_\_\_\_\_ in the Metropolitan Borough \_\_\_\_\_ and within the County of London, subject to the conditions following.

(Petroleum for light locomotives.)  
Reg. No.

that is to say—

That the total quantity of petroleum kept upon the premises hereby licensed, do not at any time exceed \_\_\_\_\_

That such petroleum be kept only in strong screw-capped metal vessels, each of a capacity not exceeding two gallons, at the places hereinafter specified, viz.—

That explosives, matches, or other inflammable or explosive substances be not in or near any place where petroleum is kept or used for charging light locomotives.

That petroleum be not kept or used in any part of the premises other than as specified in this license.

That due precautions be at all times taken for the prevention of accident from fire, and that fire or such artificial light as will ignite inflammable vapour be not within or nearer than twenty feet of the openings of buildings, or places where petroleum is kept or used for charging light locomotives.

That buildings in which petroleum is kept or used be at all times thoroughly ventilated into the external atmosphere, and that sufficient sand be kept in such buildings.

That the licensee do take effectual precautions for preventing unauthorised persons, and all persons under the age of 15 years, from obtaining access to the place of storage.

That petroleum be not allowed to enter any inlet or drain communicating with a public sewer.

That the arrangements for the storage or use of petroleum as approved by the Council and as seen by the Council's inspector last before the granting of this license, be in all respects kept and maintained, unless the consent of the Council is given in writing to any departure therefrom.

That every authorised officer of the Council be at all times allowed free access to the premises of the licensee, for the purpose of ascertaining if the above conditions are properly observed; and that the licensee do, by himself or his representatives, give any assistance for that purpose which such officer may require, and furnish samples of substances alleged to be petroleum.

By Order of the Council,

*Clerk of the Council.*

SPRING GARDENS, S.W.

Section 9 of the Petroleum Act, 1871, provides that "any licensee violating any of the conditions of his license shall be deemed to be an unlicensed person."

*This license is not transferable.*

By the London County Council (General Powers) Act, 1912, power is given to the London County Council and to the Corporation of the City of London to control to a limited extent the storage of "Petroleum Oil" to which the Petroleum Acts do not apply.

In this Act "Petroleum Oil" means petroleum as defined in the Petroleum Act, 1871, with a flash-point between 73° F. and 150° F., and any liquid, viscous, or sedimentary mixture of the same with other substances, and any inflammable oil (other than petroleum to which the Petroleum Acts apply) such as turpentine, methylated spirit or wood naphtha stored on the same premises as "Petroleum Oil."

"Petroleum Oil Depot" means any premises in the county on which petroleum oil is stored above ground level to the following amounts:—

(a) If in tanks only, 5000 gallons.

(b) In other receptacles, 2000 gallons.

Every petroleum oil depot must be registered with the London County Council or City

Corporation, which bodies may then issue regulations, subject to the approval of the Secretary of State, to diminish or prevent the risk of outflow of petroleum oil therefrom. Provision is also made for entry, inspection, and sampling by authorised officers.

## HARBOUR BYELAWS.

### THAMES CONSERVANCY.<sup>1</sup>

#### BYELAWS UNDER THE PETROLEUM ACTS, 1871 AND 1879.

*The Conservators of the River Thames, in exercise of the powers vested in them by "The Petroleum Act, 1871" and "The Petroleum Act, 1879," and of every other authority them hereto enabling, do order and direct as follows:—*

1. The Byelaws for the regulation and carrying of petroleum in the River Thames, made by the Conservators of the River Thames and confirmed by the Board of Trade on the 12th day of April 1880, shall after these present Byelaws have been confirmed by the Board of Trade be and the same are hereby repealed.

2. The expressions contained in these Byelaws shall have the meanings respectively assigned to them in the Petroleum Acts, 1871 to 1879, and in this Byelaw.

"Conservators" shall mean the Conservators of the River Thames.

"Thames" shall mean the River Thames within the jurisdiction of the Conservators.

"Petroleum" shall include any rock oil, Rangoon oil, Burma oil, oil made from petroleum coal, schist, shale, peat or other bituminous substance, and any products of petroleum or any of the above-mentioned oils which, when tested in the manner set forth in Schedule I. to the Petroleum Act, 1879, gives off an inflammable vapour at a temperature of less than 73°<sup>2</sup> of Fahrenheit's thermometer.

"Petroleum barge" shall mean any barge approved and licensed by the Conservators for the conveyance of petroleum on the Thames, except when the same is empty and certified by the Harbour Master as having been thoroughly ventilated.

"Petroleum ship" shall mean any vessel other than a petroleum barge having or intending to take on board or having discharged petroleum as cargo, except when the same is empty and certified by the Harbour Master as having been thoroughly ventilated.

"Owner" shall mean master, owner, consignee, consignor, broker, and agent.

"Master" shall mean the master or other person having the command, charge, or management of a petroleum ship or petroleum barge for the time being.

"Harbour Master" shall mean the Harbour Master or other person holding a deputation from the Conservators as a Harbour Master for the purposes of the Petroleum Acts or of these Byelaws.

"Quay" shall mean any quay, pier, jetty, wharf, landing-stairs, shore or other landing-place in or alongside the Thames.

3. No petroleum ship entering the Thames shall be navigated, lie in, or be moored, and no part of the cargo of such petroleum ship shall be discharged in any part of the Thames above or to the westward of the Mucking Light at Thames Haven.

4. All petroleum ships and petroleum barges shall, when moored or anchored, lie singly, and there shall be a clear space of not less than 100 feet of waterway kept between any such petroleum ships or petroleum barges. Provided that this byelaw shall not apply in the case of a petroleum barge lying alongside a petroleum ship for the purpose of being laden or discharged, nor to petroleum barges when lying alongside a quay and actually discharging nor to a tug and petroleum barges moored or anchored on account of fog or other exceptional causes.

5. The master of every petroleum ship shall, on entering the Thames, and during the time that such ship remains in the Thames, display at the masthead by day a red flag not less than three square feet with a white circular centre six inches in diameter, and by night a red light on the masthead in addition to any navigation lights which may be required by any other byelaws or rules.

6. Whenever any petroleum ship enters the Thames, the owner shall forthwith give notice to the Harbour Master at his office at Gravesend of the quantity of petroleum in such ship and of the manner in which such petroleum is stowed. Such notice shall be deemed to be the notice to the Conservators required by Section 5 of the Petroleum Act, 1871.

7. The master of every petroleum ship shall anchor or moor his ship below or to the eastward of the Mucking Light at Thames Haven, and in such position as the Harbour Master shall from time to time direct, and shall not remove therefrom except in accordance with the written

<sup>1</sup> Now the Port of London Authority, but the Byelaws remain unchanged.

<sup>2</sup> NOTE.—Equal to 22·7° centigrade or 18·2° Réaumur.

Former Byelaws repealed.

Interpretation Clause.

No petroleum ship to be navigated or cargo discharged westward of Mucking Light. Petroleum ships and barges when moored or anchored to lie singly 100 feet apart.

Exceptions in certain cases. Petroleum ship to display at masthead special flag by day and special light by night in addition to navigation lights.

Owner of petroleum ship to give notice of quantity of cargo and manner of stowage.

order or permission first obtained of the Harbour Master or for the purpose of forthwith leaving the Thames. No petroleum ship shall be discharged except at a place previously approved in writing by the Harbour Master.

Petroleum ships to be anchored or moored to the eastward of Mucking Light.

8. The following rules in respect of the discharge of petroleum within the Thames shall in every case be complied with:—

(a) Before any petroleum is discharged the owner shall give notice to the Harbour Master of the district in which such discharge is to take place of the time and place of such discharge and no petroleum shall be discharged during any day unless such notice shall have been given before the hour of ten in the forenoon of that day.

Place of discharge to be approved by the Harbour Master.

(b) No petroleum shall be landed at any quay other than such quay as the Harbour Master shall from time to time direct.

Rules as to discharge of petroleum.

(c) Before any petroleum in barrels, drums, or other vessels is discharged from a petroleum ship, the holds of such petroleum ship shall be thoroughly ventilated, and after all petroleum has been removed from any petroleum ship the holds and tanks shall be thoroughly cleansed. Provided that this byelaw shall not be deemed to require the cleansing of the tanks of a tank steamer which leaves the Thames immediately after the discharge of the cargo of petroleum and of which the tanks are closed up immediately after such discharge.

(d) From the time when the holds or tanks of a petroleum ship are first opened for the purpose of discharging petroleum until such time as all petroleum shall have been discharged from such ship and the holds or tanks shall have been thoroughly cleansed, as required by this byelaw, there shall be no fire or artificial light on board such ship. Provided that this byelaw shall not prevent the use of a safety-lamp of a construction previously approved by the Harbour Master.

(e) No person shall smoke, nor shall the master permit any person to smoke upon any petroleum ship when its cargo is being discharged nor shall any person engaged in the discharge of any petroleum ship carry matches or other means of producing ignition.

(f) When the discharge of petroleum has been commenced such discharge shall be proceeded with with all due speed and diligence, and should it be impracticable to complete the discharge of any petroleum ship or petroleum barge before sunset on any one day, all tanks and holds shall be securely fastened immediately such discharge is discontinued and all the same precautions taken as though bulk had not been broken. Provided that tank steamers which shall have commenced discharge before sunset shall be permitted to continue such discharge into reservoirs on shore or into tank barges.

(g) Petroleum shall not be discharged in the Thames after sunset or before sunrise except as provided in sub-section (f).

(h) Petroleum contained in barrels, drums, or other vessels which are not staunch and free from leakage shall only be discharged on shore at a duly licensed wharf and not into a petroleum barge or any other vessel.

(i) No petroleum shall be landed at any quay until the petroleum ship or petroleum barge, or carriage by which the same is to be removed therefrom, shall be at the place in readiness to receive the same, and all petroleum discharged in the Thames shall be forthwith removed therefrom or to some duly licensed place of storage.

(j) No petroleum shall be discharged or allowed to escape into the Thames.

(k) The owner shall take all due precautions for the prevention of accident by fire in the discharge of petroleum in the Thames.

9. No imported petroleum shall be conveyed up the Thames above or to the westward of the Mucking Light at Thames Haven except in a petroleum barge, and no petroleum shall be conveyed in any barge on the Thames other than a petroleum barge.

As to the conveyance of imported petroleum westward of Mucking Light.

10. The following rules in respect to petroleum barges shall in every case be complied with:—

(a) Every petroleum barge shall have the name of the owner and of the barge and the registered number of the license, preceded by the letters "T.C.," painted on the stern of the barge in letters or figures not less than six inches long and broad in proportion.

Rules as to petroleum barges.

(b) No petroleum barge shall be discharged in any part of the Thames after sunset or before sunrise except as provided in Byelaw 8 (f).

(c) No petroleum barge shall be navigated on the Thames after sunset or before sunrise, and no loaded petroleum barge shall be navigated except at such a time as shall permit as far as possible of the prompt discharge of its cargo on arrival at its destination.

(d) No loaded petroleum barge, and no petroleum barge fitted with a tank or tanks, shall be navigated or lie in the Thames unless a red metal flag not less than eighteen inches square with a white circular centre six inches in diameter, is exhibited upon such petroleum barge where it can best be seen, and no tug shall tow such a petroleum barge without also exhibiting a similar flag at the masthead.

- (e) No loaded petroleum barge shall be navigated except in tow of, or attended by, an efficient tug propelled by steam, electricity, or other mechanical power.
- (f) Not more than four loaded petroleum barges shall be towed together at one time, and these shall be towed two abreast; and not more than two petroleum barges shall be towed in single line; and no petroleum barge shall be towed alongside a tug.
- (g) No tug employed in towing a loaded petroleum barge shall at the same time tow any other barge or vessel, except barges carrying high-test petroleum; but not more than four barges shall be towed together, as provided in sub-section (f), and barges carrying high-test petroleum shall, whilst being so towed, be subject to the provisions of these byelaws.
- (h) No petroleum barge shall be navigated in a fog.
- (i) No tug shall be in attendance upon, or take in tow any petroleum barge without having on board all necessary specially designed lamps previously approved by the Harbour Master for the use of such petroleum barge in the event of its having to moor or anchor on account of fog or other exceptional causes.
- (j) In the event of it becoming necessary to show lights upon any petroleum barge through the same having to moor or anchor on account of fog or other exceptional causes, the master of such petroleum barge shall obtain such lights from the tug in attendance and he shall return the lamps to the tug immediately after use.
- No lamps shall be lighted or extinguished on board a petroleum barge, and no petroleum barge shall, when under way, have on board any lights or lamps under any circumstances whatever.
- (k) No tank compartment shall be filled above a horizontal bar fixed two inches above the base of the expansion chamber.
- (l) After any petroleum barge fitted with a tank or tanks is loaded, and before it is removed from the quay or petroleum ship at which it has been loaded, all manholes shall be screwed down gastight, all valves on suction pipes closed, and all ventilator openings securely stopped or covered with wire gauze.
- (m) No manholes, valves, or ventilators shall be opened whilst any such petroleum barge is in tow of a tug or before it has been made fast to the quay at which the cargo is to be discharged.
- (n) Before any manhole or valve is opened for the discharge of the cargo or otherwise, and continuously during such discharge and at all other times when laden, a petroleum barge shall be under the control and personal supervision of the master thereof, whose duty it shall be to prevent the access of any unauthorised person and to take all possible precautions against fire.
- (o) Immediately after the discharge of the cargo and before the petroleum barge is removed or the tug approaches for the purpose of such removal, the master shall securely close or cause to be securely closed all manholes, valves, and ventilators.
- (p) The master of a petroleum barge shall not cause or permit any fire or artificial light or matches or other means of producing ignition to be upon such petroleum barge, or smoke or permit smoking to take place on board such petroleum barge at any time.
- (q) No person when on board a petroleum barge shall have on his person any matches or other means of producing ignition, and every person on board a petroleum barge, or about to go on board a petroleum barge, shall submit to being searched by any duly authorised officer of the Conservators.
- (r) The bilges of a petroleum barge shall not be pumped when such barge is in any confined waters or is alongside any petroleum ship or tug.
- (s) A copy of this byelaw shall be posted by the owner or master in a suitable and conspicuous place on every petroleum barge.

11. No petroleum ship shall be navigated on or lie in the Thames except the same be constantly in charge of a competent person on board such ship until all petroleum on board shall have been discharged, and the master of every petroleum ship shall at all times be responsible for the carrying out of and giving effect to the provisions of these byelaws.

12. The master shall, when so required by the Harbour Master or by any police constable, show to such Harbour Master or constable all petroleum under his control upon the petroleum ship or petroleum barge, and shall afford every reasonable facility to enable such Harbour Master or constable to inspect and examine such petroleum and such petroleum ship and petroleum barge so that he may ascertain whether the provisions of these byelaws are duly observed.

13. When any petroleum ship, petroleum barge, or cargo is moored, discharged, or landed or otherwise dealt with in contravention of any of the above byelaws, the owner and master of such petroleum ship or petroleum barge, and the owner of such cargo, shall each incur a penalty not exceeding £50 for each day during which such contravention continues, and it shall be lawful for the Harbour Master to cause such petroleum ship, petroleum barge, or cargo to be removed at the expense of the owner thereof to some place at or below the Mucking Light at

Competent person to be in charge of petroleum ship, and responsibility of Master.

Inspection by Harbour Master.

Penalty for breach of Byelaws.



Thames Haven, and all expenses in or incident to such removal may be recovered in the same manner in which penalties are by "The Petroleum Act, 1871," made recoverable.

*The Common Seal of the Conservators of the River Thames was herewith affixed by order of the said Conservators in the presence of*

L.S.

ROBERT PHILIPSON,

*Secretary of the said Conservators.*

30th May 1904.

*The Board of Trade hereby signify their confirmation of the above Byelaws.*

*By order of the Board of Trade, the 11th day of June 1904.*

T. H. W. PELHAM,

*Assistant Secretary.*

### SPECIFICATION FOR TANK BARGES.

No petroleum barge fitted with a tank or tanks will be approved and licensed by the Conservators except its construction be in accordance with the following general specification :—

1. All barges shall be of steel or iron well and substantially built and strengthened with angles and bulbs, etc., as may be required. The scantlings shall be of ample proportions to suit the various sizes of barges.

2. No bulkhead shall be pierced or fitted with a sluice.

3. The petroleum shall be carried in one or more steel or iron tanks of adequate strength, divided into two compartments of equal size by a spirit-tight longitudinal bulkhead, and each compartment shall have a separate pump fitted for draining.

4. No barge shall be of a capacity greater than 150 tons.

5. No tank shall be of a greater capacity than 100 tons, and therefore no compartment shall hold more than 50 tons.

6. The tank or tanks shall be so arranged that space is left all round at the sides and ends between the tanks and the shell of the barge and the bulkheads to admit of examination.

7. The capacity of the barge between bulkheads, with tank or tanks in place, shall be such that, in the event of the contents of any one compartment escaping, the surface of the liquid in the space outside the tank shall be at least twelve inches below deck of barge.

8. Each tank compartment shall be provided with an expansion chamber of a capacity equal to at least  $7\frac{1}{2}$  per cent. of the capacity of the compartment, measured from a horizontal bar fixed at a height of two inches above the base of the expansion chamber.

9. Each tank shall be fitted with approved arrangement of pipes and valves for the discharge of the petroleum, and with manholes having screw-down covers with spirit-tight joints.

10. Ventilators to spaces round the tanks shall be fitted as required, supplied with wire-gauze covers of approved mesh and screw plugs.

11. Barges shall be properly fitted out with rudder, tiller, anchors, chains, windlass, mooring and towing bits, oars, etc.

12. No stove shall be fitted nor provision made for any means of making a fire.

### THE THAMES MOTOR LAUNCH BYELAWS, 1914.

*Byelaw 1* gives short title and date at which the byelaws come into operation.

*Byelaw 2* repeals the byelaws of 1906 so far as they relate to the Thames as hereinafter defined.

*Byelaw 3* defines various words and expressions including "the Thames" which may be taken to mean the River Thames above Teddington Lock.

*Byelaw 4* specifies the constructional requirements that must be observed by every motor launch navigated on the Thames.

*Byelaw 5* provides for the issue of licenses to motor launch owners.

*Byelaw 6* enjoins special precautions when in or waiting outside locks.

*Byelaw 7* provides for the carriage of spare petrol.

*Byelaw 8* requires the provision on board of a specified quantity of sand or an approved chemical fire extinguisher.

*Byelaw 9* deals with the production, on demand by a Conservancy official, of the special plate issued with each license.

*Byelaw 10* requires any accident by fire or explosion to be reported to the Conservators.

*Byelaw 11* deals with the penalties for infringement.

## MERSEY DOCKS AND HARBOUR BOARD.

The present Byelaws, made pursuant to the 4th Section of the Petroleum Act of 1871, and the Mersey Dock Acts Consolidation Act, 1858, were sealed by the Board, November 21, 1918.

“Dangerous petroleum” includes all petroleum as defined in the Petroleum Act, 1871, and mixtures of the same with other substances, with a flash-point below 73° F. (Abel).

“Common petroleum” includes all such petroleum with a flash-point between 73° F. and 150° F.

“Fuel oil” includes all such petroleum and all other oils with a flash-point of 150° F. and above.

**Dangerous Petroleum.**

A ship carrying dangerous petroleum in bulk as cargo may not enter any dock, but if the petroleum is contained in secure metal barrels or drums, or in tins in cases, the ship may enter any dock having a quay at which under these Byelaws dangerous petroleum may be landed, or a dock leading from the river to such dock. If the quantity so carried does not exceed 2500 gallons, the ship may enter any dock on the Liverpool side of the Mersey except the Stanley, East Waterloo, and Albert, provided the petroleum is removed immediately on landing. A ship carrying more than 300 gallons may not anchor between a line drawn from Victoria Tower to Egremont Ferry and a line drawn from New Ferry Pier to Dingle Point. A ship carrying dangerous petroleum must fly a red flag by day. The usual regulations in regard to fires and lights are imposed not only during the landing, but also during the shipment of dangerous petroleum. In fact, all restrictions on loading this material are applied *mutatis mutandis* to the shipment.

**Common Petroleum.**

A ship carrying common petroleum may enter any dock having a quay at which, under these Byelaws, common petroleum may be landed. If the petroleum is in secure metal barrels or drums or in tins in cases, the ship may enter any dock provided the petroleum is kept on board or discharged direct into craft. If the quantity does not exceed 2500 gallons, it may be landed at any of the quays of the docks on the Liverpool side with certain exceptions, provided it is removed immediately on landing. Regulations are made in regard to fires and lights on a ship carrying common petroleum as cargo and on and after the landing or shipment of the same.

**Fuel Oil.**

A ship carrying fuel oil as cargo or for its own use may enter any dock and discharge into the tanks of any other ship or into tanks on the quay provided certain precautions are observed in regard to fires and lights, and to prevent oil escaping into the dock.

## BRISTOL DOCKS COMMITTEE.

REGULATIONS FOR THE DISCHARGE AT AVONMOUTH DOCK OF  
PETROLEUM IN BULK

*To which the Petroleum Acts, 1871 and 1879, do not apply.*

1. Previous to the discharge of any petroleum, a certificate must be produced by the importer stating that the oil does not flash under 73° F., and if possible, also stating the temperature at which it does flash.

2. An application in writing must be made by the importer to the Harbour Master for permission to pump the oil from the vessel into the pipes leading to the storage tanks, or into tanks placed on the quay, and the applicant must indemnify the Corporation of Bristol against all losses, damages, costs, or expenses which they may incur or become liable for by reason of the granting of any such permission. No oil shall be allowed under any circumstances to leak or flow into the dock, or on to the quay.

3. No fires or lights shall be allowed on board the vessel during the time of discharging, except such necessary fires in the engine-room for generating steam for pumping the oil as the Harbour Master may from time to time permit; and no smoking shall be allowed on board the vessel, or any lighter lying alongside, or on the quay during such time.

4. Every possible precaution must be taken, both by the master of the vessel and by the importer, to prevent risk of fire or explosion; and also to prevent any oil being spilled on the quay, or leaking or flowing into the dock. Notice in writing must be given by the master of the vessel to the Harbour Master previous to water being pumped into the tanks of the vessel.

5. The vessel shall not, whilst in the dock, be left without a sufficient crew on board. No persons, other than the crew and such other persons as shall be employed or engaged by the importer, or by the master or owner of the vessel in connection with the discharge of the cargo, shall be allowed on board the vessel or on the quay alongside.

6. For the safer discharge of the cargo, an officer will be sent by the Harbour Master to superintend the carrying into effect of these regulations, payment being made of the expense of such superintendence by the master or owner of the vessel; and the payment of such expense of superintendence shall continue until the production to the Harbour Master of a certificate under the hand of such officer that the cargo has been duly discharged.

7. An application in writing must be made to the Harbour Master for permission to ventilate the tanks after the oil has been pumped therefrom, an intimation being given at the same time as to the mode in which it is proposed to effect such ventilation; and the Harbour Master may, in his discretion, either withhold or grant such permission, and subject to such special regulations and arrangements as he may deem necessary.

8. No lighter or other craft shall, except with the permission of the Harbour Master, lie alongside any vessel during the discharge of her cargo.

9. Every vessel having petroleum on board shall keep conspicuously exhibited from sunrise to sunset a red flag.

By Order of the Docks Committee,

F. B. GIRDLESTONE,

*Secretary and General Manager*

DOCKS OFFICE, QUEEN SQUARE,  
1st May 1890.

## MODEL CODE.

### PETROLEUM ACTS, 1871 to 1881.

Harbour of

BYELAWS.

Made of the

with the sanction of the Board of Trade.

19

1. These Byelaws shall apply to all parts of the Harbour of \_\_\_\_\_ within the Application. jurisdiction of the \_\_\_\_\_ the limits of whose jurisdiction are set forth in the schedule hereto.

2. The expressions contained in these Byelaws shall have the meanings respectively Interpretation. assigned to them in the Petroleum Acts, 1871 and 1879, and in this Byelaw.

"Petroleum" shall have the same meaning as "petroleum to which this Act applies" in the Petroleum Act, 1871, as amended by the Petroleum Act, 1879, and shall not include carbide of calcium.

"Petroleum ship" shall mean any ship having on board petroleum as cargo.

"Owner" shall mean Owner or Master of the petroleum ship or the owner of the petroleum.

"Harbour Master" shall mean the Harbour Master or other officer duly appointed by the Harbour Authority or any person having to act in such capacity.

"Quay" shall mean any quay, pier, jetty, wharf, landing-stairs, shore, or other landing-place within the harbour.

3. The Master of every petroleum ship shall, on nearing the harbour, and during the time Red flag or light. that such ship remains in the harbour, display by day a red flag not less than three feet square, and by night a red light, on the masthead (or, if the said ship has no mast, on a staff).

4. The Owner of every petroleum ship on entering the harbour shall, without delay, Notice. inform the Harbour Master of the quantity of petroleum on his ship and of the manner in which such petroleum is stowed, and this shall be deemed to be the notice to the harbour authority required by Section 5 of the Petroleum Act, 1871.

5. The Master of every petroleum ship shall anchor or moor his ship only at such place Berthing as the Harbour Master shall from time to time direct, and shall not remove his ship therefrom, ship. except for the purpose of leaving the harbour, without the written order or permission of the Harbour Master. No petroleum ship shall be anchored or moored at any place other than that approved by the Harbour Master, whether for the purpose of landing or shipping petroleum or otherwise.

6. The following General Rules in respect of the unloading of petroleum within the harbour shall be duly observed :— General Rules for landing petroleum.

- (a) Before any petroleum is landed the Owner shall give due notice to the Harbour Master of the time and place of such landing.
- (b) No petroleum shall be landed at any quay other than such quay as the Harbour Master shall from time to time direct.
- (c) Before any petroleum contained in barrels, or other vessels, is landed, the holds of a petroleum ship shall be thoroughly ventilated, and after all petroleum has been removed from any petroleum ship, the holds and tanks shall be thoroughly cleansed.

Provided that this Byelaw shall not be deemed to require the cleansing of the tanks of a tank steamer which leaves the harbour immediately after the discharge of the cargo, and of which the tanks are closed up immediately after such discharge.

- (d) Petroleum shall not be landed except between the hours of sunrise and sunset.
- (e) From the time when the holds or tanks of a petroleum ship are first opened for the purpose of landing petroleum until such time as all petroleum shall have been removed from such ship, and the holds or tanks shall have been thoroughly cleansed as required by this Byelaw, there shall be no fire or artificial light on board such ship or at or near the place where the petroleum is being landed.

Provided that this Byelaw shall not prevent the use of a safety-lamp of a construction approved by the Harbour Master.

- (f) The Owner shall not allow any smoking at or near the place where petroleum is being landed, nor shall he allow any person engaged in such landing to carry fuzees, matches, or appliances whatsoever for producing ignition.
- (g) No petroleum contained in casks, barrels, or other vessels shall be landed in the harbour, unless such vessels are staunch and free from leakage, and are of such strength and construction as not to be liable to be broken or to leak, except in case of gross carelessness or extraordinary accident.
- (h) When the landing of petroleum has been commenced, such landing shall be proceeded with with due diligence.
- (i) No petroleum shall be landed at any quay until the ship or carriage by which the same is to be removed therefrom shall be at the place in readiness to receive the same, and all petroleum landed in the harbour shall be forthwith removed therefrom, or to some duly licensed place of storage.
- (j) No petroleum shall be discharged or allowed to escape into the waters of the harbour.
- (k) The Owner shall take all due precautions for the prevention of accident by fire in landing petroleum.

7. Two or more petroleum ships shall not, except for purpose of transshipment, lie within 100 feet of one another, unless, in the opinion of the Harbour Master, it is impracticable to maintain such distance.

8. Every petroleum ship shall be watched by a competent person on board such ship until all petroleum on board shall have been landed, and every petroleum ship shall at all times have on board a responsible person to carry out and give effect to the provisions of these Byelaws.

9. The Owner shall, when so required by the Harbour Master, or other officer duly appointed by the Harbour Authority, or by any police constable, show to such officer or constable all petroleum under his control or upon his vessel, and shall afford every reasonable facility to enable such officer or constable to inspect and examine such petroleum so as to ascertain whether these Byelaws are duly observed.

Where any ship or cargo is moored, landed, and otherwise dealt with in contravention of any of the above Byelaws, the Owner and Master of such ship and the Owner of such cargo, as the case may be, shall each incur a penalty not exceeding fifty pounds for each day during which such contravention continues, and it shall be lawful for the Harbour Master or any other person acting under the orders of the Harbour Authority to cause such ship or cargo to be removed at the expense of the owner thereof, to such place as may be in conformity with the said Byelaw.

## PETROLEUM LAMPS.

### SUGGESTIONS FOR THE CARE AND USE OF PETROLEUM LAMPS.

*(Issued by the Secretary of State for the Home Department.)*

1. The wick should quite fill the wick-tube, without having to be squeezed into it.
2. Before using, the wick should be dried at the fire, and then immediately soaked with oil.
3. Wicks should be in lengths of not more than ten inches, and should always reach to the bottom of the oil container.

4. It is well to change the wick after two months' use.
5. See that the chimney of the lamp fits properly and is held sufficiently tightly so as not to fall off when the lamp is used.
6. When a new wick or chimney is required, it is always advisable to take the burner to the shop that it may be properly fitted.
7. The burner should be taken to pieces and thoroughly cleansed at least once a month, and all burnt pieces of wick, dead flies, dirt, etc., should be carefully removed.
8. Never refill the lamp when it is alight, or near a fire or other light.
9. After filling see that the burner is properly fixed on, and if there is a side filling-hole, be careful to screw in the plug.
10. Before lighting, remove the burnt crust of the wick.
11. Be careful not to spill oil in filling, and, if any is spilt on the lamp, wipe it off.
12. Before lighting see that the slit in the cone of the burner is exactly over the wick-tube, so that the flame will not touch the metal.
13. When first lit, the wick should be partially turned down, and then gradually raised, but not so as to smoke. When the edge of the flame is orange-coloured the lamp is not burning properly, and the burner should be examined.
14. Do not continue to burn the oil until it is completely exhausted. It is best to keep the lamp well filled.
15. Lamps which have no extinguisher should be put out as follows :—The wick should be turned down until there is only a small flickering flame, care being taken not to turn down so far that the wick falls into the oil container. The small flame may be extinguished by placing a piece of flat tin or card on the top of the chimney, or by blowing across the top of the chimney. Never blow down the chimney.
16. Never use a lamp which is broken or in any way out of order, or a chimney which is cracked. If any part comes loose, or is out of shape, or defective, it should be taken to a lamp shop to be repaired.
17. Always place the lamp on a secure place and on a level surface, and never on a rickety table, or in any position where it could be easily upset. Hanging lamps should not be put on insecure nails in the wall.
18. Table lamps should not be carried about more than is necessary, and nothing else should be carried at the same time. Heavy lamps should be carried in both hands. The greater number of lamp accidents have been caused by dropping a lamp while it was being carried.
19. Lamps should not be turned down except for the purpose of putting them out. If turned low the oil is apt to be unduly heated.
20. Should a person's clothes become ignited, the flames should be smothered with a hearth-rug, blanket, woollen table-cloth, or wet towel.
21. NEVER POUR OIL ON A FIRE.

WHITEHALL,

1st November 1901.

## FOREIGN AND COLONIAL.

### ANTIGUA.

*Gunpowder and Petroleum Acts* :—No. 12, 1874 ; No. 9, 1889 ; No. 9, 1890 ; No. 23 of 1899 and No. 4 of 1904, read together.

The first of the above Acts empowered the Governor to appoint a fitting place beyond the limits of the City of St. John as a petroleum store, and prohibited storage elsewhere, except for private use (with a limit of 10 gallons), or for retail sale (with a limit of 20 gallons, increased by the 1899 Act to 96 gallons, with a power of the Treasurer to authorise a further quantity up to 200 gallons). The 1899 Act also allows of the warehousing of petroleum in bond in places approved by the Governor. Licenses for sale (retail) to be granted by the Treasurer, for terms of three months, subject to a stamp duty of 1s. A standard of test was introduced by the Act of 1889, the minimum fixed being 83° F. (Abel test). All oils flashing below the standard are classed as "volatile petroleum," and their importation is prohibited under penalty of forfeiture and fine, unless the importer furnishes proof of ignorance of their low-test

quality (when reshipment is allowed), an exception being made in favour of oil not intended for burning, if kept in closed glass bottles of a capacity not exceeding 8 ounces, and of gasoline (Act of 1890) for use in scientific or technical work, or in the Government Laboratory, under permission from the Governor. The Act of 1904 allows of the importation of "volatile petroleum" for use as fuel in manufactures or in oil engines subject to conditions imposed by the Governor. Three samples must be furnished by importer for testing by the Government analyst or other appointed person before the oil is landed, and samples may be drawn by the Treasurer from oils in store for retesting at any time.

### AUSTRALIAN COMMONWEALTH.

By a Proclamation dated 16th November 1904, under the Customs Act, 1901, it is provided that no mineral oil shall be imported as kerosene unless it has a flash-point of 73° F. (Abel-Pensky) or over. Petroleum below this flash-point is to be termed mineral spirit, and may only be imported in strong vessels not liable to be damaged or to allow their contents to escape. Such vessels are to be marked, "Naphtha," "Benzine," "Benzoline," or "Gasoline," as the case may be, together with the words "Highly inflammable." The Abel-Pensky test apparatus is described in a schedule.

In Melbourne, Byelaws Nos. 49 and 114 have been made regulating petroleum spirit and petroleum oil respectively, the flash-point being fixed at 73° F. (Abel). Quantities of petroleum oil, turpentine, etc., exceeding 250 gallons, may only be kept on premises approved by the Town Council.

### NEW SOUTH WALES.

#### *Inflammable Liquid Act, 1915.*

"Inflammable liquid" means liquid petroleum as defined in the Petroleum Act, 1871, having a flash-point (Abel-Pensky) below 150° F. and any other liquid prescribed by the Governor.

"Mineral spirit" means an inflammable liquid having a flash-point below 73° F.

"Mineral oil" means an inflammable liquid having a flash-point of 73° F. and above.

Premises on which inflammable liquid is kept must be licensed or registered subject to certain specified exceptions. Conditions regarding quantities, situation, construction, and management of places of storage are laid down.

General rules are made to govern the marking of packages and the conveyance of inflammable liquid.

Inspectors are appointed and their powers defined.

Wide powers are given to the Governor to make regulations to carry into effect the provisions of the Act.

### QUEENSLAND.

#### *The Petroleum Act of 1915.*

This Act deals only with the mining of free petroleum by boring or wells. Petroleum is the property of the Crown with power to grant a just reward to the discoverer of a new field. The Minister of Mines is given powers to enter and occupy land subject to limited compensation.

## SOUTH AUSTRALIA.

*Inflammable Oils Acts, 1908 and 1909.*

The Kerosene Storage Act, 1873, and Amendment Act, 1874, are repealed. "Inflammable oil" means any liquid derived from petroleum, shale, schist, coal, peat, bitumen, or any similar substance with a "flash-point" (Abel-Pensky) of less than 150° F., and any other liquid prescribed by the Governor. "Petrol" means inflammable oil flashing below 73° F., and "Kerosene" inflammable oil flashing at or above that temperature. In and within 5 miles of the boundaries of municipalities, towns, and townships, inflammable oil may only be kept under license or registration, except—

(a) In quantities not exceeding:

- (1) Four hundred gallons of kerosene if all petrol kept within 50 feet is separated by a "screen-wall";
- (2) One hundred gallons of kerosene if any petrol is kept within 50 feet and is not separated by a "screen-wall";
- (3) Fifty gallons of petrol, provided all in excess of 5 gallons is in substantial closed metal vessels, each containing less than 10 gallons.

(b) During conveyance.

(c) In the fuel tank of a motor carriage or ship.

Under the conditions in (1) and (2), 800 gallons and 300 gallons of kerosene may respectively be kept on "registered premises" subject to certain rules. Also, one hundred or two hundred gallons of "petrol" may be so kept, according as the place of storage is within or without a municipality, town, or township.

The conditions under which "stores" are licensed and the rules governing the keeping of inflammable oils therein are fully set forth.

Packages containing "petrol" must be conspicuously marked "Highly inflammable," and no one may keep, convey, or sell kerosene with a flash-point below 100° F., unless each package is marked "Kerosene, for use in oil engines."

The conveyance of inflammable oil is strictly regulated and provision made for inspection, search, seizure, and forfeiture; and for appeal to the Court of Full Jurisdiction. Inflammable oil under the control of Government is exempted. The Governor is given very extensive powers to make regulations under the Act, but there is a power of Appeal to the Supreme Court.

## TASMANIA.

*The Inflammable Oils Act, 1910.*

"Petrol" is defined as having a flash-point less than 73° F. (Abel-Pensky), all above that being "kerosene." Petrol may be kept without license or registration:

- (1) To an amount not exceeding 50 gallons;
- (2) While in course of conveyance;
- (3) In the fuel tank of a motor carriage or ship.

Two hundred gallons of petrol may be kept on registered premises subject to conditions, and any quantity may be kept under license.

Provision is made for keeping "kerosene" and carbide of calcium, and for marking packages of petrol, kerosene, and carbide. The method of conveyance, loading, and unloading of inflammable oil of both kinds is specified, and provision made for inspection and testing. Government oil is exempted.

Regulations of a comprehensive character may be made by the Governor, but there is a power of Appeal to the Supreme Court.

The Governor may declare any liquid to be an inflammable oil, and any place to be a "protected work."

"The Kerosene Storage Act, 1875," is repealed.

#### AUSTRIA.

*Law of 23rd January 1901.*

A flash-point of 70° F. (Abel) is prescribed, and petroleum is classed according to whether it is above or below this flash-point—the 1st class comprising all mineral spirits, and the 2nd class mineral oils. Quantities exceeding 20,000 kilos. of oil or 1000 kilos. of spirit require a license from the Industrial Authorities, and the place of storage in the case of spirit must be not less than 60 metres from other buildings. The keeping of smaller quantities may be licensed by the police. Retailers may keep 15 kilos. of spirit and 50 kilos. of oil; or, if metal tanks are used, the quantity of oil may be 300 kilos. Regulations are made as to precautions in storage. Lightning conductors and specified methods of preventing outflow must be provided in large stores. No artificial method of lighting stores may be used, and all business is to be carried on in daylight. Smoking and the introduction of inflammable articles is prohibited. When oil and spirit are kept together without an intervening fireproof wall, the whole is to be regarded as spirit. The regulations do not apply in the case of oil-fields, factories in which petroleum is manufactured or used for technical purposes, or to temporary storage during transport. Petroleum spirit is to be marked "Highly inflammable"; and, when sold in quantities under 50 kilos., "Special precautions to be employed when used for burning purposes. Not to be opened near a light, and to be kept in a cool place." This, however, does not apply to spirit used for fuel or for chemical use.

#### TRIESTE.

*Regulations of the Petroleum Harbour at S. Sabbia, 1891.*—The control of the petroleum harbour at S. Sabbia is vested in the officials of the port, except in so far as concerns the State railway or other department of the State. The police and other arrangements at the goods yard are under the control of the railway officials. Tank-steamers have precedence over all other vessels for stations in the harbour, and rank amongst themselves in the order of their arrival. Sailing vessels or other steamers, lying at the wharf for loading or unloading barrels or cases, must give place to tank-steamers when required. Vessels must be so moored that they can be cast loose. No reduction may be made in the number of hands on board until unloading is completed and the vessel has left her moorings. Tank-steamers may use steam-pumps, worked by steam from the boilers, for unloading; other steamers may use cranes or winches for the same purpose, provided the boiler for generating the steam is in the usual boiler-room. The only light allowed on board petroleum vessels is that approved by the harbour authorities. On steamers, a lamp is allowed in the galley, and cooking may be done on board if water is kept at hand for use in case of fire; but for sailing vessels, the cooking must be done on shore in an appointed spot, unless the harbour officials are satisfied that it may be safely conducted on board. No stoves may be lighted so long as the vessel remains alongside the wharf. Smoking is forbidden, both on board and within the limits of the petroleum stores on shore. Unloading or loading must proceed at the rate



of 400 barrels, at least, per diem, Sundays, holidays, and bad weather excepted. For this purpose, 5 cases are considered as the equivalent of 1 barrel. The oil must be taken away by the consignees as it is landed. Admission to the petroleum stores is only allowed under special permission in the case of private persons not working therein. Foremen must be provided to superintend by day and night, and it is part of the foreman's duty to see, after the cessation of work for the day, that all lights and fires are properly extinguished. Pumping-out steamer tanks between sunset and sunrise is only allowed in exceptional cases, and by the special permission of the harbour authorities, and similar permission is necessary for the filling of tank-cars, barrels, or cases. The storage of full or empty cases or barrels, or of easily inflammable substances, in the open, is forbidden. In sheds and boiler-houses, a supply of water must be kept at hand, in case of fire, together with hand-pumps strong enough to force a jet up to the ceiling. No fuel or inflammable substances may be placed on boilers or near the fire doors. So long as the boiler is in use, a qualified person must be present in the boiler-room, and the pumps and boilers may only be left unattended when all fires and lights are extinguished. The soldering of petroleum tins may only be effected in a place set apart by the authorities, containing a plentiful supply of sand or ashes and shovels ready to hand. No open light is allowed in the precincts of the stores, nor are petroleum lamps allowed in closed rooms.

*Regulations of the Captain of the Port, 15th May 1879.*—Petroleum may be loaded in small quantities, and under the supervision of the harbour authorities, into lighters in the old port. Such boats, having petroleum on board, must remove from the shore at sundown, or, if prevented by bad weather from so doing, must be guarded by a watchman. No fires, open lights, or smoking allowed while petroleum is on board. All petroleum lying on the quay, waiting to be loaded, must be under guard, but can only be allowed to so remain under exceptional circumstances. Steamers of the Austro-Hungarian Lloyd Co., lying at the quays, are allowed to take petroleum on board, provided this is effected on the day of departure and completed by sunset, and that the vessel is under the surveillance of two watchmen, as in the case of lighters detained at the quay.

*Storage.*—Storekeepers must observe all the general regulations governing the sale of combustibles. No petroleum may be stored in a retail shop. A specially constructed metallic vessel, sufficient to hold about a barrel, must be provided for storage, and this must be enclosed in a pit lined with brick, the roof being arched and covered with a paving stone. Through a hole in the cover projects a metal filling pipe, well soldered to the vessel, and provided with a screw stopper. The space between the bottom of the storage receptacle and the flooring of the pit must be filled with sand to absorb outflow of oil. The storage of empty cases or barrels in retail shops is prohibited.

#### BAHAMAS.

##### *Kerosene Oil Act, 1914.*

“Kerosene oil” is defined as all kerosene and paraffin oils, naphtha, gasolene, and all hydrocarbons with a flash-point of 94° F. or above when tested as prescribed by the “Rules.” Not more than 1000 gallons may be kept except under prescribed conditions. “Rules” may be made by the Governor (1) to regulate the importation, transport, and keeping for use or for sale, (2) to specify the method of testing, (3) generally for carrying the Act into effect.

## BARBADOS.

*Petroleum Act, 1882, and Amendments, 1892 and 1903.*

The standard test is 83° F. (Abel). Any oil flashing below this point is termed "volatile petroleum." All wholesale storage of petroleum must take place in the Government warehouse. For retail purposes, 200 gallons in metal vessels, or 50 gallons in wooden vessels, may be kept in a shop or store. No "volatile petroleum" may be imported under penalty of forfeiture. Comptroller of Customs draws samples of cargo, which are tested by the Professor of Chemistry. Provision is made for retesting in case the owner objects to the result of the test.

By the "Fuel Oil Act, 1917," fuel oil is defined as oil residue, distillate, or oil fuel derived from petroleum with a flash-point of not less than 150° F. Licenses may be granted by the Governor to import and keep, and rules may be made by him to govern landing and keeping.

## BELGIUM.

*Royal Decrees of 29th January 1863, 8th December 1868, and 31st May 1887.*

Places of storage of petroleum and other inflammable liquids are classed according to the nature of the liquid and the quantity kept. A license must be obtained from the Local Authority for the keeping of more than 50 litres of petroleum oil or 20 litres of petroleum spirit. The flash-point is not specified by Royal Decree, but is probably laid down by local regulations, as are also the conditions under which the petroleum may be kept.

The Royal Decree of the 8th December 1868 contains byelaws for the conveyance of petroleum on rivers and canals.

## ANTWERP.

The quantity of oil to be kept by the retailers is limited to two barrels. Harbour byelaws, dated the 2nd September 1867, regulate the landing of petroleum.

## BERMUDA.

*Petroleum Act, 1887.*

The Act applies to petroleum giving off an inflammable vapour at less than 73° F. (method of testing not specified, but it is presumably the Abel test), and chiefly relates to harbour regulations for import vessels. No low-test oil may be kept without license, otherwise than to the extent of 3 gallons in separate well-stoppered vessels holding not more than 1 pint. These vessels are to be labelled "Highly inflammable," and to bear owner's, sender's, or vendor's name. Licenses are under the control of the Governor. Fraudulent importation, or sale, of low-test oil is punishable by penalty. By the Expiring Laws Continuance Act (No. 1), 1909, the Bermuda Petroleum Act, 1887, is continued in force until 1914.

## BRITISH BALUCHISTAN AND BRITISH BURMA.

The *Petroleum Acts of India* (*q.v.*) apply.

## BRITISH GUIANA.

*Petroleum and Inflammable Liquids Ordinance, 1916.*

"Petroleum" means kerosene oil, rock oil, Rangoon oil, Burma oil, paraffin oil, and their products, any oil made from petroleum, coal, schist, shale, peat, or other bituminous substance, methylated spirit, ether and carbon bisulphide, and any mixture containing them, and includes any other inflammable liquid "proclaimed" by the Governor.

"Dangerous petroleum" means petroleum with a flash-point below 85° F. (Abel or Abel-Pensky).

"Oil fuel" means petroleum with a flash-point of 130° F. and above.

Every vessel carrying petroleum as cargo may be moored only as directed by the harbour-master, and no "dangerous petroleum" is allowed into the Colony except in staunch metal barrels or drums.

Licenses are required for the storage of petroleum exceeding 425 gallons (or, if for private use, 100 gallons) and for any quantity of "dangerous petroleum."

Powers of entry, search, and sampling are given to the police and other officials, and regulations may be made by the Governor to regulate the management of licensed buildings, the landing and conveyance of petroleum and the quantities that may be kept. The Petroleum Ordinance, 1872, and the Amendment Ordinance of 1909 are repealed.

By the "Customs Duties Ordinance, 1911," a duty of 1 cent per gallon is leviable on crude petroleum, or 25 cents on refined petroleum with a flash-point above 85° F. For petroleum with a lower flash-point (other than gasoline, petrol, and crude petroleum) the duty is 3 dollars per gallon, and for petrol 5 cents.

## BRITISH HONDURAS.

*Dangerous Goods Ordinance, No. 10, of 1878.*

Standard 100° F. (open test) flashing-point.

Limit of quantity to be stored without license, 10 gallons (and this only for private use), unless 50 yards distant from a dwelling-house or store. Conditions of license are left to the Local Authority. Provision is made for the appointment of inspectors for testing, and for searching suspected premises.

By the Petroleum Ordinance, 1913, the Abel test is substituted for the open test, but no corresponding reduction in the flash-point is made.

## TOWN OF BELIZE.

*The Belize Inflammable Liquids Ordinance, 1906.*

The Governor may by Order in Council declare any liquid to be an "Inflammable liquid," and may prescribe the quantity that may be kept in any one place; he may also appoint a special warehouse for the deposit of "Inflammable liquids" in bond, and a public wharf where they may be landed on importation. Provision is made for search, seizure, and forfeiture.

## CANADA.

*Petroleum Inspection Act, 1899.*

"Petroleum" is defined as refined products of mineral oil, coal-tar, etc., weighing more than 7.75 lbs. per gallon, and "naphtha" as such products weighing less than this amount. The refining of petroleum may not be carried on without a license. Petroleum may not be sold for illuminating purposes unless its flash-point is above 85° F., and it weighs between 8.17 and 7.75 lbs. per gallon. The Abel test is prescribed. Heavy oils may be sold for illuminating purposes under regulations made by the Inland Revenue Department. Naphtha may only be sold for illuminating purposes in vapour lamps under certain conditions, or for manufacturing purposes. Provision is made for inspection and for the forfeiture of petroleum sold or offered for sale without having been inspected. The storage, importation, conveyance, shipment, and sale of petroleum are subject to regulations made under the Act.

By the Petroleum Bounty Act, 1909, the Governor in Council may authorise the payment of a bounty of 1½ cent per gallon on all crude petroleum having a specific gravity of not less than .8235 at 60° F. produced from wells or shales in Canada; to be divided among those interested in the proportion approved by him.

## CAPE COLONY.

There is no general law in Cape Colony relating to the importation and storage of mineral oils. The only regulations on the subject in the Colony are those framed by the Local Authorities. These specify the quantity that may be stored in premises without license. The limit varies considerably, being only 20 gallons in some places, while in others it is as much as 100 gallons.

## CEYLON.

*Petroleum Ordinance, 1887. Petroleum Rules, 1896.*

"Dangerous" petroleum is defined as flashing below 76° F. (Abel test), a margin of 3° being allowed where a cargo is declared to be of uniform quality (the samples tested must average 73° flashing-point, and none must be below 70°). Lubricating oil flashing at over 200° F. is exempted. More than 3 gallons of "dangerous" petroleum cannot be imported or stored without license, unless kept in separate vessels, securely stopped, and holding not more than 1 pint. Applications for licenses must specify quantity to be stored, nature of premises, and description of storage vessels; must set forth the purpose for which the petroleum will be used; and must declare that only "dangerous" petroleum can be employed for that purpose. Vessels must be labelled "Highly inflammable," and must bear a description of the contents (in English, Cingalese, and Tamil), together with the name of the consignee, sender, or vendor. The Governor may specify the ports at which petroleum can be admitted, and may make regulations for discharging and storing; he may also fix the number of samples to be tested, and arrange for the retesting and division of cargoes lacking uniformity. No quantity of petroleum exceeding 50 gallons may be kept except under license from the Local Authority. Hawking is regulated by provisions similar to those of the English Act of 1881, the limit of quantity for each carriage being 24 gallons. Penalties and confiscation are entailed by breaches of the Act. Petroleum flashing above 120° F. may be exempted by the Governor from the operation of the Act. Powers of search of suspected premises are granted under warrant.

Rules relating to the importation, storage in quantities exceeding 100 gallons, inspection, conveyance, and licensing of petroleum, were gazetted on the 10th January 1896.

CHANNEL ISLANDS—See GUERNSEY AND JERSEY.

CHINA.

There are no general regulations relating to the transport of petroleum in China. At the open ports, the Customs regulations provide for the berthing of vessels carrying petroleum in a certain portion of the harbour. At Shanghai the Municipal Council for the Foreign Settlements forbids the storage of petroleum within the limits of the Settlements, but allows each vendor to have not more than ten cases at any one time on his premises. At the other open ports the regulations are practically the same. In China, probably each city has its own regulations, but what they are is unknown to Europeans.

CYPRUS.

*Petroleum Acts of 1883 and 1892.*

No test standard is prescribed. Not more than 30 okes (750 fluid ounces) of petroleum, contained in separate well-stoppered vessels of a capacity not exceeding 12 okes (300 fluid ounces) each, may be kept, either for private use or for sale, except under license from the Municipal Authorities.

DENMARK.

*Regulations of 1st November 1892, 1st February 1903, 27th July 1903,  
and 31st December 1903.*

These regulations apply to all inflammable liquids, which are divided into two classes according to whether the flash-point is above or below 73° F. (Abel-Pensky). These classes are termed A and B.

**Storage.**—A manufacturer or shopkeeper may not keep in an inhabited house, for immediate sale or use, more than 4·7 gallons of Class A or 1 gallon of Class B. There may not be kept in any building (presumably in a town) more than 188 gallons of Class A or 38 gallons of Class B. Stocks are considered to be in the same building unless a fireproof partition or space of 10 feet intervenes between them. The stocks must be in metal vessels, or, in the case of Class A, in barrels; and if the quantity exceeds 94 gallons of Class A or 19 gallons of Class B, they must be kept in well-ventilated vaulted cellars, and if there is woodwork in the construction of the cellars, this must be covered with cement or galvanised iron. Windows and ventilators must be covered with galvanised iron netting of not more than 5 mm. mesh.

**Sale.**—Petroleum spirit may not be sold in lots of less than 1·4 Danish pounds, and must be marked "Inflammable. It must not come near a fire or unprotected light."

**Loading and Discharging.**—For the purpose of regulating the loading and discharging of inflammable liquids in Danish waters, these liquids are divided into three classes as follows:—

**Class A.**—Liquids with a flash-point above 70 F. (Abel) and a specific gravity below 0·680.

Class B.—Liquids above a flash-point of 70° F. (Abel) and having a specific gravity below 0.680 and 0.760.

Class C.—Liquids with a specific gravity above 0.760.

Liquids of Class A must be contained in metal, glass, or stoneware vessels; those of Classes B and C may be conveyed similarly or in barrels. Inflammable liquids may not be conveyed in passenger boats.

By the new Customs Tariff of 1908 the import duty of 2 croners per 100 kilos. has been abolished.

#### COPENHAGEN.

Byelaws for regulating petroleum, both above and below a flash-point of 21° C. (Abel), were made on the 8th May 1897.

#### DOMINICA.

##### *Petroleum Act, 1874.*

Standard test 100° F. (presumably open flash test). No testing regulations. Limit of quantity to be stored for private use, or sale, 17 gallons, except in places appointed by the Governor. No sale allowed except under license from Magistrates, who may authorise storage of more than 17 gallons. Appeal to Governor allowed against Magistrates' refusal to grant license. Governor may make regulations for storage warehouses. Magistrates may issue search warrants, and aggrieved persons may appeal to Supreme Court.

#### FALKLAND ISLANDS.

Apparently no regulations.

#### FIJI.

##### *Storage of Oil Ordinance, 1915. Petroleum Ordinance, 1918. Customs Duties, Ordinances, 1881 to 1900.*

By the Storage of Oil Ordinance, 1915, "oil" means petroleum as defined in the Petroleum Act, 1871, having a flash-point below 150° F. (Abel) and imported in bulk for fuel purposes for the supply of shipping, and such "oil" is exempted from the provisions of the Kerosene Storage Ordinance, 1877.

Provision is made for the erection of storage tanks for "oil" and for the compulsory acquisition of land for this purpose, and in a schedule to the Ordinance regulations are set forth governing the erection and maintenance of these tanks, and the importation, landing, and storing of "oil."

By the Petroleum Ordinance, 1918, petroleum means petroleum as above defined which has been imported otherwise than in bulk. Apparently all petroleum is to be treated alike, as no flash-point is mentioned, nor is there any reference to "volatile" or "dangerous" petroleum. The Governor may, however, exclude from the definition such products of petroleum as he may deem expedient, and as the provisions of the Ordinance are such as are usually applied to petroleum spirit, it is presumably intended that he should be guided by the flash-point prescribed in the Kerosene Storage Ordinance, 1877, viz. 78° F. (Abel). Not more than 20 gallons may be kept in certain towns and areas except in a "magazine." Regulations may be made by the Governor in regard to the conditions to be attached to licenses for "magazines," and he also may prohibit by proclamation the importation of any particular variety of petroleum. The Kerosene Storage Ordinance, 1877, is repealed.

## FRANCE.

The earliest regulations in France were formulated in the *Decrees* of 18th April and 31st December 1866, relating to dangerous or noxious occupations,<sup>1</sup> the manufacture and distillation of petroleum, shale- and tar-oils, and allied substances being placed in the 1st category of such trades, because of the smell and the danger of ignition. Storage dépôts were classified in the 1st or 2nd category, according to the character (*i.e.* whether the flashing-point was below or above 35° C.) of the oil stored. A further classification was made on the basis of quantity, stores containing between 1050 and 10,500 litres of standard-test oil, or 150 and 1050 litres of low-test oils, being considered as belonging to the 2nd class, and those containing over 10,500 litres of standard-test oil, or over 1050 litres of low-test oil, as in the 1st class. A little latitude was allowed, by the letter of instructions to the prefects, in the case of a storekeeper receiving a fresh supply before his stock was quite exhausted. The mode of ascertaining the degree of inflammability was prescribed by these regulations (see Section IX., pp. 764 and 800). Storage dépôts were to be on the ground floor or in a cellar, the floors of cemented stone, and the door sills of stone, 1 decimetre above the floor, the dividing walls in the case of cellars being of 30-centimetre masonry. Stores on the ground floor were to be of one story only, the roofs resting on iron supports, and all dépôts properly ventilated and well lighted by daylight only. No wood was permitted in any part of the structure. The only receptacles or storage vessels allowed were stoppered metal bottles, sound iron-bound casks of 150 litres maximum capacity, or carboys of glass or earthenware protected from breakage by osier baskets, or packing in straw, etc., and holding not more than 60 litres, and transport was permitted only in such vessels. It was further prescribed that the transfer of oil from one vessel to another should only take place in daylight, and should, as far as possible, be effected by means of pumps. A few fixed lights were allowed in stores, but at a distance from the more inflammable oils, as also from those being retailed, and only absolutely safe, closed, portable lights were permitted when additional lighting became necessary. Smoking, fire, and the storage of empty barrels or other combustible matter were prohibited, and sand was to be kept in readiness to extinguish an outbreak of fire. An interesting portion of these early regulations is that which takes the form of advice to the users of mineral oils for illumination. The recommendations were substantially as follows:—Lamps should have the container large enough to hold more oil than would be burned at one time of using. Containers should be strongly made of transparent glass to facilitate inspection of the contents, and the fittings should be securely attached by means of a cement impervious to the oil, care being also taken that there were no apertures in the fittings to form a communication with the tube carrying the wick. Heavy pedestals to minimise risk of overturning, as well as extinguishing and trimming appliances, were recommended. A caution was given against the carrying about of lighted lamps, and suggestions were made in reference to replenishing. In case of the chimney breaking, the lamp was directed to be extinguished, to prevent overheating of the metallic fittings and

<sup>1</sup> These occupations were divided into three classes, viz. :—

I. Trades which might, by reason of their unpleasant nature and danger, only be carried on at a distance from inhabited houses.

II. Occupations for which isolation was unnecessary if proper precautions were taken for public safety.

III. Pursuits not liable to become obnoxious, but which must be under police surveillance.

the consequent danger of explosion, and the superiority of sand, earth, or ashes to water in case of fire was pointed out.

The present laws in France are epitomised in the following:—

*Abstract of the Decree of the French Government relating to the manufacture and storage of, and wholesale and retail trade in, petroleum, 19th May 1873.*

By this decree, petroleum and its products, shale- and tar-oils, spirits and other liquid hydrocarbons for lighting, heating, the manufacture of colours and varnish, cleansing and other purposes, are divided into two classes—those giving off inflammable vapour below 35° C. being included in Class I., and all others being grouped under Class II., the mode of testing to be determined by the Minister of Agriculture and Commerce, with advice from the Consulting Committee on Art and Manufactures. By an Order dated the 19th September 1903, the application of this Decree is limited to oils below a fire-test of 135° C. Factories for manufacturing, distilling, and using any of the above substances on a large scale, are placed in the 1st class of dangerous, insalubrious, and objectionable establishments, as set forth in the Decree of 15th October 1810, and the Ordinance of 14th January 1815. Stores and entrepôts, where the articles in question undergo a simple washing with cold water, or transference from one vessel to another, are classified as follows in accordance with the system prescribed by the foregoing decrees:—

*1st Class* when containing over 3000 litres of liquid of the 1st category (or the equivalent in the 2nd category).

*2nd Class* containing 1500 to 3000 litres of the same.

*3rd Class* containing between 300 and 500 litres.

Five litres of liquid of the 2nd category are taken as the equivalent of 1 litre of the first for the above classification, and other inflammable liquids, such as alcohol, ether, carbon bisulphide, etc., are divided into the 1st or 2nd category on exactly the same basis as the petroleum products. The places of storage must be surrounded by a wall at least 2½ metres high, with only one opening which must lead into a public road, and be closed by a strong iron-plated door kept locked from nightfall till morning, the key to be kept by the proprietor or his deputy. All workmen entering or leaving the premises by day must be under strict surveillance. The only dwelling for occupation at night, allowed within the walls, is the watchman's house, and this must be isolated by a wall at least 1·2 metre high, without opening. No buildings of any kind may be erected within 50 metres from the external walls of the store in the case of stores of the 1st class, and 4 metres in the case of stores of the 2nd class. The stationary plant or storage tanks must be at least 50 centimetres from the wall, and must admit of ready inspection. The flooring of the stores must be flagged or cemented and provided with gutters running into covered cisterns large enough to hold the entire liquids stored—in case of accidental leakage or spilling—and all must be kept in a serviceable condition. If the store is of sufficient capacity, and is either partly underground or surrounded by an efficient wall without any opening, the cisterns may be dispensed with. Any warehouse or shed used for storage must be of one story only, incombustible, and well ventilated in the roof. Storage tanks must be of metal with movable covers, or iron-bound wooden vessels, and fixed, oil-tight pumps must be used for transferring liquids of the 1st class to vessels at higher levels. No empty casks or litter of any kind may remain in the store. All operations, such as receiving, storing, weighing, and delivering, must



take place only by daylight, access to the store at night being strictly prohibited, as well as smoking or the introduction of any fire, light, or matches. (*N.B.*—In the South of France, Italy, and Spain, portable charcoal fires are much used.) This prohibition must be conspicuously exhibited near the doorway. For extinguishing any outbreak of fire, a sufficient quantity of sand or earth must be kept close by the store. The Magistrates, subject to the approval of the Minister of Agriculture and Commerce, may impose any further special restrictions in the interest of public safety, and may also, subject to the same conditions, grant licenses on other terms offering the same degree of security. Stores of the 2nd and 3rd class, and those for liquids of Class II., are subject to the same regulations, but small stores for less than 300 litres of liquids of Class I., or the equivalent in liquids of Class II. (*viz.* 1500 litres), require no license. The proprietor must, however, lodge with the Mayor of the Commune and the Prefect of Arrondissement, a minute description of the surrounding locality. These stores are subject to the same regulations as others, for ensuring safety, and must be partly underground and surrounded by a bank of earth or masonry to prevent outflow. The regulations applicable to the retail trade are briefly as follows:—The retailer must give the Mayor and Sub-Prefect an exact description of the place, quantity, mode of storing, and delivery, and must store liquids of Class I. in proper metal vessels having not more than two apertures, effectually closed by tap or stopper, transference into other storage receptacles not being permitted. These vessels must not hold more than 60 litres each, and are to be plainly and indelibly marked “Inflammable spirit”; they are to be kept isolated from the rest of the goods in the shop, and provided with a vessel attached to the tap to collect any droppings. Storage in cellars is forbidden, and for the prompt extinction of fire, a sufficient quantity of sand or earth must be kept on the spot. Delivery to customers may be made only in properly stoppered and labelled tins, filled direct from the storage vessels, and all such transfers may be made during daylight only. If the oil is kept stored in cans ready for delivery, and holding not more than five litres each, contained in a metal-lined box forming a tank, delivery by artificial light is permitted. Liquids of Class II. are to be stored in metal tanks holding not more than 350 litres, plainly marked “Mineral oil.” Retailers are not allowed to keep a greater stock than 300 litres of liquids of Class I. or their equivalent. The retailer may store the liquids in original packages in warehouses or stores, in a yard or other detached space, provided the buildings are isolated from any building containing combustibles, are well ventilated, kept locked, and are surrounded by a solid earth, brick, or stone wall forming a cistern to prevent outflow. Additions may be made to the foregoing regulations, in the interest of public safety, by the Prefect, under advice from the Sanitary Council. Traders already licensed under the old law may continue, but may not make any alterations except in conformity with these rules, and any contravention of the same on the part of any trader or storer will be visited by fines and closing of the premises. Transport of all inflammable liquids must take place exclusively in suitable metal tanks or wooden barrels. This decree revokes that of 27th January 1872, and amends that of 31st December 1866, in so far as relates to the storage of hydrocarbon liquids. Prefects of Police are vested with the powers conferred by this decree on Prefects, Sub-Prefects, and Mayors, and the execution of the decree is vested in the hands of the Minister of Agriculture and Commerce.

The question having arisen as to how far the regulations in the decree of the 19th May 1873 are applicable to the retail trade, in respect to inflammable

liquids of the second class, the Minister of Commerce addressed a Circular Letter, dated 22nd November 1893, to the Prefects of Departments, stating that the Consultative Committee on Arts and Manufactures, having deliberated on the subject, had come to the conclusion that, while the restrictions as to carrying on all operations in daylight only, the stores being closed at night, applied to large stores, irrespective of the class of liquid contained in them, it was not intended that they should apply to retail establishments, except as regards liquids of the first class—*i.e.* flashing below 35° C.—and that, consequently, retailers of high-test oil (Class II.) are not debarred from selling by artificial light.

**Testing.**—The first testing directions were prescribed by the decree of 31st December 1866, the weight of a litre of the oil being fixed at 800 grams, minimum, and the standard igniting-point at 35° C. The test was applied by heating the oil in a copper cup, 6 to 7 centimetres in diameter by 2 to 3 centimetres in depth, placed in a water bath. When the temperature reached 35° C., as indicated by a thermometer placed in the oil, a lighted match was to be drawn across the surface of the oil and then plunged into the liquid. If the match was extinguished without igniting the oil, the latter was considered to have passed the test. In order to remove the objection that at the moment when the thermometer indicated 35°, the oil itself would be at a somewhat higher temperature, it was provided that, in case the owner of the oil raised this objection, the test should be repeated by heating the oil up to 36° or 37° C., allowing it to cool, and applying the match at the instant the thermometer marked 35°.

The testing instrument now employed, under an Order dated 5th September 1873, is the Granier, a description of which is given on p. 800. The standard of test remains the same, *viz.* 35° C., although the apparatus records the flashing-point of the oil, whilst with the tester previously in use the ignition point was taken.

By a decree issued on the 29th December 1910, the provisions of Articles 2, 4, 5 (3°), and 17 of the decree of 19th May 1873 were amended, the following being an abstract of the alterations:—

Stores and entrepôts in which low-test petroleum is not handled except for the purpose of transference from one vessel to another are placed in the 1st, 2nd, or 3rd classes of “dangerous establishments,” according as they contain the following quantities:—

*1st Class* when containing more than 6000 litres.

*2nd Class* when containing 1500 to 6000 litres.

*3rd Class* when containing 300 to 1500 litres.

Garages for automobiles are included in the above, but where the petroleum is contained only in closed metal vessels, each holding not more than 10 litres, it is to be reckoned as one-third of its actual volume, provided that this shall not allow more than 15,000 litres in stores and entrepôts of the 2nd class. If high-test petroleum is kept, a quantity of 5 litres is reckoned as 1 litre of low-test. When other inflammable liquids, such as alcohol, ether, carbon disulphide, etc., are also kept, these are to be included as high- or low-test petroleum, according to their flash-points.

The regulation as to distances from other buildings is modified in the case of stores, etc., of the 1st class, so as to allow in special cases a reduction from 50 metres to not less than 10 metres.

Low-test petroleum may only be conveyed in staunch metal vessels, substantially constructed, and hermetically closed. High-test petroleum may be

conveyed in wooden barrels, provided they are staunch and hooped with iron. This regulation is not, however, to come into force for five years from the date of this decree; up till then low-test petroleum may be carried in wooden barrels hooped with iron.

By an Ordinance of the Prefect of Police, dated 10th January 1911, the above was made to apply to Paris as well as to the Department of the Seine.

## GAMBIA.

*The Petroleum Ordinance, 1905.*

The owner or master of any ship carrying petroleum must, on entering the Port of Bathurst, give notice to the Collector of Customs and moor his ship in such a place as the Collector directs. All petroleum is stored on entry in Government stores and is tested. Any petroleum with a flash-point below 95° F. (Abel) must at once be reshipped. No petroleum flashing below 95° F. (Abel) may be kept in the colony. Provision is made for sampling, search, seizure, and forfeiture. Petroleum, in quantities greater than 10 gallons, may not be kept elsewhere than in a Government store, except by virtue of (a) a store license, or (b) a hawker's license, forms of which are set forth in Schedules to the Ordinance, and the fees for which are not to exceed £3 and £1 respectively. In case of refusal by the licensing magistrate there is a power of appeal to the Governor. The Governor in Council may issue regulations appointing places for landing and storage; specifying the methods of landing, sale, carriage, and hawking; fixing the conditions and terms of licenses and the fees payable; and generally for the better carrying out of the provisions of the Ordinance. The Governor in Council may by order subject any substance to the provisions of this Ordinance, specifying in the Order the quantity that may be kept without a license and the marking of packages; he may also exempt such quantities as may be required for purposes of medicine, science, or other purpose approved by him.

The Petroleum Ordinance (No. 10), 1899, is repealed.

## GERMANY.

## BERLIN.

In August 1902 police regulations were issued governing the traffic in mineral oils, including crude petroleum and its distillation products, oils of low boiling-point, illuminating oils, and light lubricating oils; liquids prepared from coal-tar, such as solar oil, benzol, etc. These inflammable liquids are divided into three classes, viz.: (1) Those which at 760 millimetres pressure have a flash-point below 21° C.; (2) those having a flash-point between 21° C. and 65° C.; and (3) those having a flash-point above 65° C. The Abel-Pensky is the test employed.

## CLASS I.

In living rooms, bedrooms, kitchens, corridors, offices, in hotels and public-houses not more than 2 kilograms may be kept, and then only in securely closed vessels, or in vessels fitted with a safety device. Transfer of liquid from one vessel to another must only take place by daylight, by a light from outside, by electric light, or by the use of an electric or Davy safety lamp.

Retailers may keep on their business premises 15 kilograms, provided these premises are detached from living rooms, bedrooms, etc. (as above), or are

separated from them by smoke- and fire-proof doors. Otherwise the quantity is limited to 2 kilograms.

The spirit must be kept in staunch tins fitted with taps, and the above regulations as to transfer from one vessel to another must be observed.

Quantities exceeding 15 kilograms, but not exceeding 250 kilograms, may only be kept on registration with the local police, and in well-ventilated cellars or rooms on the ground level separated from all other rooms by substantial walls and ceilings, and secure against outflow or leakage into the streets, drains, etc. The spirit must be kept in hermetically closed metal vessels, and the part used for storage must be separated from all other inflammable or explosive articles. The doors must open outwards. The transfer of liquid from one vessel to another must be by means of a tap or pump, and be carried out only by daylight or suitable artificial light. Smoking is prohibited. Provision is made for storage in the open air, provided outflow is prevented.

Quantities exceeding 250 kilograms, but not exceeding 2000 kilograms (or 50,000 kilograms if kept in tanks), may only be kept under license from the local police. This license is to require a distance of 20 to 30 metres to be maintained from protected works, according to local conditions.

Quantities exceeding 2000 kilograms (or 50,000 kilograms in tanks) may be kept only in special stores under license from the general police. This license, unless special circumstances appear to render relaxation desirable, must require the following conditions to be observed:—

(a) Quantities exceeding 50,000 kilograms must be kept in tanks.

(b) The part of the store used for the storage of the spirit must either lie lower than the surrounding ground, or must be surrounded by a substantial mound of earth at least 0.5 metre thick at the top. In either case the enclosed space must be sufficient to contain three-quarters of the total amount of spirit that may be present, and must be surrounded by a protected zone 50 metres wide. The mound must not be interrupted either by exits or drains, and the gangways over it must be of fireproof material.

(c) If the spirit is kept in sheds inside the sunken or mounded part of the premises, these, if built of wood, must be covered on the outside with good roofing boards reinforced with fireproof material. A lightning conductor must be fitted and efficient ventilation provided. The windows must be protected with wire netting or glazed with wire glass.

Tanks must be tested before use by being filled with water, and must be fitted with efficient lightning conductors connected to the tanks, if these are of iron. At the highest point of each tank an iron ventilating pipe is to be fitted, with its open end at such a height from the ground that escaping vapour cannot be accidentally or carelessly ignited. Inside the pipe, at equal intervals, at least three fine mesh wire gauzes must be placed in such positions as to be easily inspected and renewed.

(d) Buildings may not be erected nor inflammable material stored in the protected zone round the store. Filling sheds, weighing and pumping houses in certain circumstances are to be regarded as storehouses so far as the protected zone is concerned.

(e) On storage premises work may only be carried on by daylight or by electric light, and in the sheds by external light from approved lamps which must be lit off the premises. The windows outside which the light is placed must be permanently closed. An arc-light may only be used in the open air, electric glow lamps under special conditions being employed inside the rooms. Fire or open light, except where specially allowed, may not be taken on to the storage premises, and smoking is also forbidden.

(f) Pits, sheds, and tanks for the storage of spirit may only be placed in or on ground which is impermeable to liquid and firm enough to bear the weight. Relief is provided if this is impracticable.

(g) When tanks are employed which can be inspected through manholes, two life-lines and two sets of breathing apparatus must be kept on the premises. Before an inspection the tanks must be cleared of vapour by thorough ventilation.

(h) Access to the storage premises after working hours is only to be allowed to the watchman and to authorised persons.

Regulations are made to govern the carriage of liquids of this class in carboys.

#### CLASS II.

In living rooms, bedrooms, etc., not more than 25 kilograms may be kept. Retailers may keep in separate vessels up to 50 kilograms, and in cask up to 200 kilograms. Under stricter conditions 600 kilograms may be kept.

Quantities exceeding 600 kilograms, but not exceeding 10,000 kilograms, may be kept only under registration with the local police. The oil must be kept in cellars or on the ground floor with simple precautions.

Quantities exceeding 10,000 kilograms, but not exceeding 50,000 kilograms, may only be kept under license from the local police. No protected zone need be maintained if the whole of it is kept underground, otherwise modified "distances" must be observed.

For quantities above 50,000 kilograms, a license must be obtained from the general police.

#### CLASS III.

For quantities not exceeding 10,000 kilograms, it is only necessary to prevent outflow by excavation or by the provision of impermeable and fire-proof retaining walls.

For the storage of quantities exceeding 50,000 kilograms, it is necessary to register with the local police and to keep in special storehouses. Provision must be made to prevent outflow, and only closed lamps may be used on the premises.

If it is desired to keep more than 50,000 kilograms, a modified protected zone must be maintained.

#### *General Provisions.*

When inflammable liquids of various classes are kept together, the whole quantity is deemed to be liquid of the more dangerous class, and regulated accordingly.

Rules are laid down to govern the keeping of empty vessels. Petroleum-producing stations and motor cars are exempted from these regulations.

#### BREMEN.

##### *Law of 3rd May 1872.*

The law relates to all oils which give off inflammable vapour or ignite easily (except vegetable and animal oils), and all kinds of liquids possessing the same properties. The classification is as follows:—

(a) Oils and liquids giving off inflammable vapour at a temperature below 30° Réaumur (100° F.).

(b) Oils and liquids giving off inflammable vapour at 30° Réaumur or above. The quantities and authorised modes of keeping are—

Retail Shops.	Stores. <sup>1</sup>
Class (a) 100 lbs., . . . . .	1500 lbs.
Class (b) 300 lbs., . . . . .	3000 lbs.

In shops (other than chemists' shops) the liquids must be kept and delivered in well-closed, completely filled vessels of metal, glass, china, or earthenware, and containing no more than 50 lbs. The opening of such vessels, and transference of the contents into other vessels in shops, is prohibited. The liquids, if not used for burning, must be kept in well-closed vessels of metal, glass, china, or earthenware. In excess of the foregoing quantities, the liquids must be kept in public warehouses approved by the police authorities. Use of fire or matches, and smoking, are prohibited in warehouses and stores, as well as on board ships laden with inflammable liquids. Naked lights are generally prohibited, but in a shop, fixed gas-jets or well-protected lamps or lanterns are allowed, though no exposure of inflammable liquids may take place by artificial light.

*Loading, Landing, and Storage of Petroleum and Solar Oil.*

*Senate Law, 26th November 1866.*

This decree provides, that in view of the inflammable nature of these oils, all quantities exceeding 1000 lbs. (German) must be kept in a specially appointed store under police supervision. Masters of vessels arriving are to give notice to the Harbour Authorities, stating what quantities of crude or refined oils are on board, and to moor their vessels according to directions. No loading, discharging, or removal of petroleum vessels is allowed without special permit. Fires, lights, and smoking are prohibited on petroleum vessels.

*Testing Regulations of the Bremen Petroleum Exchange, relating to Colour and Flashing-Point.*

The proprietor of a parcel of petroleum wishing to have its colour and (or) flashing-point tested, must send his barrels, marked for identification, to the quay or the wharf, and forward to the test office a signed declaration with the fees as determined by the Exchange.

The barrels will be sampled and the samples mixed by the testing officials as follows :—

	Up to 100 brls. 6 brls. to be sampled, equal to 2 test samples.			
From 101 to 200	9	9	3	3
„ 201 to 300	12	12	4	4
„ 301 to 500	15	15	5	5
„ 501 to 700	18	18	6	6
„ 701 to 1000	21	21	7	7

Over 1000 barrels, 2 per cent. are sampled, or as many over 2 per cent. as shall be necessary to make the number of samples a multiple of 3. Closing the barrels after sampling is to be done by the owner or at his expense. For testing the flashing-point, the Abel apparatus (approved by the Imperial Commission

<sup>1</sup> The stores must be well ventilated, situated in cellars or basements, entirely separated from other parts of the premises used for trading, industrial, or domestic purposes, and kept locked. There must be no drains communicating with premises on a lower level; sewers, etc., are allowed.

of Standards and in accordance with the Imperial Chancellor's Schedule, 20th April 1882) is used.

If all the samples pass the standard test of 21° C. flashing-point, at 760 millimetres pressure, the parcel they represent is declared tenderable on spot and forward-delivery contracts, and each barrel is marked as complying with the test of the Bremen Petroleum Exchange ("Reichstest der Bremen Petroleum Börse").

*N.B.*—Corrections are made for barometric pressure according to a table published by the Chancellor (see p. 789). If any of the samples flash below 21° C. at 760 millimetres, then the parcel is condemned as not tenderable on contracts. In such case, the owner can have it retested in parts of not more than 100 barrels each, making a fresh declaration for each parcel. Oil flashing below 21° C. must be branded on the barrels as "highly inflammable," or, at the request of the owner, may be marked with the interim stamp of the Exchange, provided he furnishes an acceptable guarantee that such oil shall not be entered into the German Empire for sale. For testing the colour of the oil, Wilson's chromometer is the standard instrument used. The following is the classification:—(1) Prime white; (2) standard white; (3) prime light straw to white, to standard white; (4) prime light straw to white; (5) light straw; and (6) straw. The colour is indicated on the barrels by one of the preceding numbers added to the test stamp. If the owner is not satisfied with the result of the colour test, he can have the test repeated on any part of the parcel. For oil, not below standard white in colour, which passes the test of flashing-point, a certificate to that effect is given; for all other oils, the certificate is given according to quality. Such certificates are to be signed by the Director of the test office or the second official.

#### PORT OF BREMERHAVEN.

##### *Regulations of the Harbour Board for the Discharging, Loading, and Storing of Petroleum and Solar Oil (mineral oil distilled from lignite).*

15th April 1877.

Vessels carrying these oils will, as a rule, and provided that their admission is consonant with the harbour regulations, be allowed to enter the Kaiserhafen only. The captain must report to the Harbour Authorities the nature of his cargo, and the number of barrels which it comprises, before entering the dock, the maximum penalty for omission being 20 marks per barrel. Watchmen are appointed, at the ship's expense, to ensure the absence of all lights, fire, and matches, and to prevent smoking. Cargo must be discharged immediately the ship is at the berth, care being taken to avoid blocking up gangways on board or on shore. Storage is effected in the manner prescribed by the regulations of 18th September 1874. Vessels loading must leave immediately the cargo is all on board. Vessels discharging must be thoroughly cleansed, dunnage wood stored or disposed of by direction of the Harbour Authorities, and all rubbish taken ashore at once. The Harbour Authorities are empowered, in certain circumstances, to refuse admittance to the harbour, or to expel from the harbour ships already admitted, and to impose fines for breaches of these regulations.

For tank-steamers importing petroleum in bulk, the following regulations are in force:—Tank-steamers about to discharge their cargo in the Kaiserhafen with their own steam must get up steam in the roads. In putting out the boiler

fire, it must not be raked out on to the floor-plate, but allowed to burn out in the fire-box. Sampling the oil and driving out the vapour from the tanks must be carried out in presence of the official watchman, and in the roads. While the vessel is in the Kaiserhafen, no tank hatches may be unscrewed except of those tanks actually being pumped out, and these covers must only be raised sufficiently to admit air for the prevention of rarefaction in the tank. Hatchways may only be completely opened during daylight, and when the tanks are empty, and the covers must be replaced without loss of time. The boiler arrangements must conform to the Imperial Regulations, and be open to examination by the inspector of boilers. The pump boiler chimneys must be provided with spark catchers. Due notification to the authorities of the arrival of a tank-steamer is compulsory, and the consignee is responsible for the conveyance of the necessary watchman on board while the vessel is still lying in the roads.

### HAMBURG.

*Law of 20th December 1882.*

Law applies to—A. “Crude petroleum and its lighter products” (including refined petroleum having a flashing-point below 21° C. (69·8° F., Abel-Pensky test). B. Refined petroleum and turpentine.

Class A. may be stored up to 50 kilograms without any license, but subject to the following regulations:—The liquid must be kept in tin vessels bearing prominently on a red ground the words “Highly inflammable,” and must be handed to the purchaser in vessels similarly labelled. The sale must take place by daylight, and the store must not be entered with a naked light. When the liquid is low-test refined petroleum, a metal vessel for keeping is not compulsory. Low-test refined petroleum may only be stored within the limits of the petroleum harbour, except by special permission, under which dealers may store on their premises up to 150 kilograms provided the vessels are marked “Highly inflammable,” and, in addition, “Special precautions to be taken if used for burning,” if sold in vessels containing less than 50 kilograms.

Class B.—On private premises outside the petroleum harbour, refined highest oil may be stored up to 50 barrels without special license, subject to the following regulations:—(a) The storage place must be surrounded by massive walls. (b) The storage place must have no communication with sewers, canals, streets, or courts. (c) The flooring must be at least 0·6 metre below the level of the street or court, and must always be covered with a layer of sand 0·3 metre thick. (d) The storage place must be detached. (e) Smoking is strictly prohibited. (f) Only “ball lanterns” may be used if artificial light is required. Turpentine may be stored up to 800 kilograms without special license, and subject to the above regulations (a) to (f). There are regulations as to landing, shipment, etc.

Special licenses are required for quantities exceeding:—of Class A, 50 kilograms; of Class B, 50 barrels; and of turpentine, 800 kilograms. But when the quantity of oil or turpentine exceeds one barrel, it must be kept in a detached and specially constructed store with provision against escape.

### *Harbour Regulations.*

Vessels carrying crude petroleum and its lighter products, refined petroleum, or turpentine, must report on arrival to the officer of the guardship at the Ionas, and a declaration must be made by the captain of the quantities he has on



board. Ships having crude oil or the lighter products on board must anchor at a safe place in the lower part of the Elbe near Twielenfleth, and may only discharge with the sanction of the Harbour Police Authorities, and under conditions imposed by them. Vessels laden with refined petroleum or turpentine may discharge in the petroleum harbour only. No lights or fires are allowed on board, no smoking is permitted, and the hatches must be kept open to prevent the accumulation of explosive vapour.

#### HANOVER.

*Police Order of 7th February 1903.*

The regulations for the Province of Hanover resemble those for Berlin, but with some differences in the quantities to be stored under the various conditions. A third class is added, to which belongs oil flashing between 149° F. and 284° F., and for this class the principal precaution enjoined is the prevention of outflow. Oils above a flash-point of 284° F. are exempt from the regulations, as also is spirit carried in motor cars.

#### GIBRALTAR.

*Ordinance, 23rd February 1884.*

Importation of petroleum flashing below 73° F. (Abel) is prohibited, except such as is required for military purposes. With the same exception, the limit of quantity which may be landed and stored for private use, or otherwise, is 24 gallons, unless under license from the police magistrate (who may impose suitable conditions). All licenses are registered by the Justices' Clerk. The captain of the port is authorised to regulate the mooring of vessels carrying petroleum, subject to the approval of the Governor. Breach of this ordinance is punishable by penalty and confiscation of the oil. The Justices may authorise search of suspected premises, and obstruction of search party involves fine and confiscation of oil found.

By the Petroleum Amendment Ordinance, Gibraltar, 1905, which may be read as one with previous enactments, the Governor is given power to apply the Petroleum Ordinance, 1884, to any substance subject to the following qualifications:—

- (1) The quantity that may be kept without a license shall be specified.
- (2) The meaning of the word "Gibraltar" shall be defined.

#### GOLD COAST.

*Petroleum Ordinance, 1916.*

Petroleum is defined as in the Petroleum Act, 1871, but no flash-point is specified. Not more than 100 gallons of petroleum or 50 gallons of "petrol" may be kept without a license, but "petrol" is not defined. Rules may be made by the Governor in Council to carry into effect the provisions of the Ordinance.

#### GREECE.

The sale of petroleum was established as a Government monopoly by decree of 1st February 1884. Central depôts are established at Corfu, Patras, Syra, Pyraeus, and Volo. There has been no legislation on the subject since the above date.

## GRENADA.

*Inflammable Goods Ordinance, 1891.*

The standard test is 80° F. (Abel), all low-test oil being classed as "volatile petroleum." Importation of volatile petroleum is prohibited under penalty of forfeiture and imprisonment. Consignees must give notice to the Treasurer within six hours (Sundays and holidays excepted) of the vessel's arrival, and must send at least three samples to the Government inspector to test. The landing and storage of standard-test oil are allowed at places appointed by regulations. The consignee of volatile petroleum may be allowed to re-export within thirty days on proof of ignorance of the low-test quality of the oil. Appeal against Inspector's test is decided by competent persons; fees to follow result. In the port of St. George no oil is to be landed except between 7 a.m. and 4 p.m., unless by special permission. No more than 2 cases are allowed on private premises nor more than 12 cases on traders' business premises. Not less than 4 cases may be taken out of the petroleum warehouse at a time, unless in the case of the balance of an importer's stock. Revenue and police officers have the right to search suspected premises.

By the Inflammable Goods Amendment Ordinance, 1898, the Governor in Council may allow the importation of volatile petroleum "for fuel or in substitution for steam," subject to such restrictions as he may impose.

By a further Ordinance, dated 14th October 1904, the Governor in Council may grant licenses to import "volatile petroleum," which may be kept only in the petroleum warehouse or in a registered storehouse. It must be contained in metal vessels, and marked "Volatile petroleum—highly inflammable."

By the Inflammable Goods Ordinance, 1908, all explosives as defined in the Explosives Act, 1875, are brought within the provisions of the Inflammable Goods Ordinance, 1891.

## GUERNSEY.

*Law of 16th July, 1914.*

"Inflammable oils" mean all mineral or vegetable oils or essences or other substances of the same nature with a flash-point below 73° F. (Abel-Pensky). A new principle is introduced in that restrictions largely depend on the method of packing. The expressions "safely bottled" and "safely packed" are defined, the latter expression including metal barrels of 60 gallons capacity.

Twenty-four hours' notice must be given to the Supervisor by an importer, and fees are payable in respect of inflammable oils which are not "safely packed." If "safely packed" such oils may be landed, shipped or transhipped as ordinary cargo, and may be deposited on the quay at any place indicated by the harbour-master.

No dealer may keep or sell inflammable oils without a license from the Supervisor (with right of appeal to the Royal Court) unless the whole quantity kept does not exceed 3 gallons and is "safely packed." Conditions governing licenses are specified in two Schedules and a scale of fees is laid down. Special conditions apply to quantities exceeding 2000 gallons.

Subject to specified conditions the following quantities may be kept without license:—

- (a) For domestic purposes in a dwelling-house, one pint.
- (b) For purposes of trade and machinery, but not for sale, 25 gallons and a further 25 gallons in tanks of machines.
- (c) In motor boats, unlimited.

Sale at night and hawking are forbidden unless the oils are "safely packed."

Powers of inspection and search are given to constables and to the authorised inspector, and to the Royal Court to declare the substances to be regarded as "inflammable oils," to regulate the handling of new substances so declared, to issue licenses in special cases, and to pass the necessary Ordinances.

The previous laws on the subject are repealed.

#### HOLLAND.

The law of 1901 lays down the conditions under which petroleum will be accepted for rail transport, the consignor being required to furnish a certificate that these conditions are complied with. The conditions are as follows:— Petroleum having a flash-point above 21° C. (Abel), and a specific gravity above 0.780, may be contained in tank-wagons, barrels, metal vessels, or specially packed glass or earthenware vessels. Crude oil or petroleum having a specific gravity between 0.780 and 0.680 may be carried as above; but packages must be marked "Danger of Fire," and, in the case of bottles or jars, "To be carried in the hands." This marking also applies to petroleum spirit below a specific gravity of 0.680, which, however, may not be conveyed in wooden barrels.

The law of 2nd June 1875, as amended by the law of 24th June 1901, requires a license to be obtained for the erection of any petroleum refinery or store which may be a danger or nuisance. The conveyance of petroleum on the Rhine is controlled by byelaws dated 2nd May 1905 and 17th March 1910.

#### AMSTERDAM.

##### *Police Regulations of 10th March 1909.*

Inflammable liquids—that is, liquids immediately igniting on coming in contact with a flame—are divided into three classes as follows:—

Class A.—Liquids having a boiling-point above 76° C., and mixing with water in all proportions.

Class B.—Petroleum and other liquids with a boiling-point below 76° C. and not mixing with water, and all mixtures of petroleum having a flash-point above 21° C. (Abel).

Class C.—Petroleum and other liquids not mixing with water, and mixtures of the same having a flash-point below 21° C. (Abel).

The quantities which may be kept are:—of Class A, 1000 litres; Class B, 400 litres; and Class C, 50 litres. Liquids of Class C may only be kept in 5-litre metal vessels or in  $\frac{1}{2}$ -litre bottles.

Not more than 100 empty barrels may be kept in one lot. Separate lots must be divided by a brick wall 22 centimetres thick or by an open space of 10 metres.

Provision is made for a Municipal Petroleum Depôt.

**Conveyance.**—Classes B and C may only be conveyed in 200-litre vessels, and must not be left on or near a road at night. Not more than 2000 litres of Class B or 250 litres of Class C may be conveyed by land, and not more than 40,000 litres of Class B or 1250 litres of Class C by water. Vessels carrying these liquids must not remain within the municipality at night, and must not moor within 200 metres of other vessels carrying the same kind of cargo. Provision is made as to giving notice, and as to police protection of the cargo.

## ROTTERDAM.

*Fire Regulations of 9th September 1902.*

A flash-point of 21° C. (Abel-Pensky) is laid down. Inflammable liquids above this flash-point may not be kept in quantities above 250 litres or within 1 metre of a light. Inflammable liquids below this flash-point must be kept in 2-litre cans, the maximum quantity being 25 litres, and must not be within 3 metres of a light. Retailers must obtain the permission of the Corporation to deal in inflammable liquids.

**Conveyance.**—Oils must be conveyed in tank-wagons, which must not be left on public roads or quay except under police supervision at owner's cost. Regulations dated 5th December 1901 deal with the storage and manufacture of petroleum at certain specified places.

The Regulations were amended on 7th March, 27th June, and 6th September 1907, and on 12th November 1908.

## HONG KONG.

*The Dangerous Goods Ordinances of 1873 (No. 8), 1884 (No. 7), 1899 (No. 39), 1901 (No. 34), and 1902 (Nos. 8 and 20)* empower the Governor to prescribe conditions of storage under license, kerosene for private use up to 10 gallons, kept in closed vessels containing not more than 3 gallons each, being exempted. License to store in shops up to 40 gallons is granted, provided that the petroleum is kept in the original tins and stored in a brick-lined well, fitted with an iron-lined wooden lid for protection in case of fire (4th May 1880). For stores, the premises must be either of brick or stone, with concrete floor, plastered up to the door sill (3 feet from floor) with Portland cement. Ventilation must be effected by windows on both sides, protected by wire-netting and sun-blinds. Roof must be of four thicknesses of tiles, or double-tiled with plaster ceiling. A 10-foot wall must surround the building at a minimum distance of 10 feet, and the sill of the door or gate in the said wall must be 3 feet from the ground inside. No kerosene may be stored above the window sills. No leaky tins, matches, lights, or unlicensed combustible articles may be kept on the premises. The store must remain closed between 6 p.m. and 6 a.m. from October to March, and between 7 p.m. and 5 a.m. from April to September. Licensees must notify every month, to the Superintendent of the Fire Brigade, the quantity of kerosene in stock. Ventilators must be provided with iron shutters and metal shades. Soldering is allowed only in a specially-constructed sunken space surrounded by a wall 2 feet high and having a cemented floor, with drain leading to a small well, to collect waste oil. Damaged cans may be kept only in an open shed with tiled roof. Lubricating oils, and petroleum having a flash-point above 150° F., are exempted from some of the provisions; but no test is specified. The Governor in Council has power to make byelaws regulating the landing, shipment, and conveyance of petroleum.

An amending Ordinance (No. 27) was issued in 1910 introducing certain immaterial alterations. This may be read with the Dangerous Goods Ordinance, 1873, as amended by the Dangerous Goods Amendment Ordinance, 1902.

## INDIA.

*Indian Petroleum Act, 1899.*

In this Act "petroleum" includes all the various mineral oils and spirits, and all products and liquid or viscous mixtures thereof, but does not include lubricating oils which have a flash-point above 200° F. (Abel-Pensky).

“ Dangerous petroleum ” means petroleum having a flash-point below 76° F. (Abel-Pensky); but where one lot of petroleum is said to be of uniform quality, and the average flash-point is above 73° F., it is not to be considered dangerous petroleum if no one sample flashes below 70° F. The Abel-Pensky test is prescribed. Dangerous petroleum, in quantities exceeding 40 gallons, may not be imported without a license from the Local Government. Dangerous petroleum may not be kept or conveyed without license, the keeping of 3 gallons in pint vessels being exempted as in the United Kingdom. The provisions as to marking are similar to those in this country. The Governor-General in Council may make rules to carry out the purposes of the Act. Rules as to importation, sampling, refining, and storage of petroleum, are made by the Local Government. Ordinary petroleum, in quantity exceeding 500 gallons, may not be kept or conveyed without license.

Under Section 9 of the Act power is given to the Local Governments to make rules to regulate the importation, keeping, and transport of petroleum, but in December 1908 draft consolidated rules to be uniformly adopted in India were issued by the Government to the Local Governments for final issue.

By these rules licenses are required, as stated above, but special relief is granted in the case of petroleum with a flash-point above 150° F. Licenses to keep dangerous petroleum for use in motor vehicles are granted free of charge, subject to conditions very similar to those contained in the Order of Secretary of State (see pp. 988-990), except that a vessel may contain as much as 4 gallons and that the petroleum in the tank of a motor vehicle is deemed to form part of the 60 gallons allowed in a “ storehouse.” Forms of license are attached.

#### ISLE OF MAN.

*Dangerous Goods Acts, 1871 and 1881. Storage Regulations, 12th May 1882.*

“ Petroleum ” under the first-named Act included all products of naphtha and petroleum oils flashing below 100° F. (open test), but the Act of 1881 amended this definition so as to include all petroleum products. A license from the Governor is required for the storage of petroleum, with the following exceptions:—(1) In the case of oil flashing below 73° F. (Abel): a quantity not exceeding 1 gallon, kept in well-stoppered vessels holding not more than a pint each, whether for private use or sale. (2) In the case of other petroleum: a quantity not exceeding 40 gallons. Any oil kept in contravention of the Act may be confiscated, and a fine inflicted on the offender. All low-test oil kept beyond a period of seven days after landing, conveyed to any place on the island, or exposed for sale, must be plainly labelled with the words “ Highly inflammable,” in addition to the description, and marked with the name and address of the consignee or owner, sender or vendor. *Test.*—The standard is now 73° F. (Abel), and the mode of testing is the same as in the English Act of 1879. Storage licenses are granted under the following conditions:—The place used as a store may be either an open space or a shed of one floor only (with an exception in favour of a one-floor shed having a vault underneath, provided the other conditions are complied with), the floor of which must be sunk 2 feet below the surrounding surface, or have a wall 2 feet high surrounding it, made perfectly secure against outflow or leakage, and properly ventilated to prevent the accumulation of petroleum vapour; having, in addition, a well to receive the leakage from any of the storage vessels, such well not being in communication with any public drain or sewer. No other goods may be kept in a petroleum store, except such as are not combustible. No smoking, lights,

fires, or matches are allowed in stores, or on ships or other conveyances during loading, unloading, or conveying petroleum in greater quantity than 36 gallons; and no delay, beyond what is absolutely necessary, is allowed in the carrying out of these operations, eighteen hours being allowed for the loading and discharge of vessels. Petroleum ships must conform to harbour regulations or orders of Harbour Master with respect to moorings, etc. Inspectors are appointed by the Governor, and may search suspected premises, under warrant from the High Bailiff or Justice of the Peace, being authorised to seize any petroleum kept in contravention of the Act. Officers of Customs, head constables, and inspectors and sergeants of police may exercise the same powers without warrant, and any person obstructing such entry or seizure is punishable by fine. If objection is raised against the inspector's test, the Court may appoint a public analyst or other competent person to decide.

#### ITALY.

In Italy, the different Municipalities have power to frame their own regulations for the storage, etc., of petroleum, subject to the approval of the Provincial Deputation and the Home Office, under the *Law of Public Safety, No. 9, 20th March 1865 (Arts. 88 and 89)*. Carriage of mineral oils by rail is subject to the same conditions as that of explosives and other inflammable materials. The above-mentioned Law empowers the Provincial Deputations to proclaim and prohibit the establishment of noxious, dangerous, and objectionable manufactures.

A regulation dated 13th July 1903, provides for the shipping, conveyance by sea, and landing of dangerous goods, amongst which petroleum is included. These goods are separated into classes, and petroleum is declared to belong to a different class according to whether its flash-point is above or below 21° C. No test appears to have been prescribed.

The same distinction is made in the case of the Railway Regulations, dated 1st June 1897 and 18th August 1900.

On 19th March 1911 a law was enacted regarding the sinking of petroleum wells and specifying the fees to be paid. This was amended by further legislation on 21st January 1912.

#### GENOA.

By Municipal Regulations issued in 1909 inflammable liquids are divided into two classes, *i.e.* those with a flash-point below and above 21° C. (Abel), and comprehensive rules are laid down as to their manufacture, storage, sale, and transport. Magazines for storage in bulk are licensed (1) for above 3000 litres of Class I., and above 15,000 litres of Class II., and (2) for 500 to 3000 litres of Class I., and 2500 to 15,000 litres of Class II. The situation and construction of magazines are specified. Special provision is made for keeping for use in automobiles.

#### NAPLES.

By a Municipal Order dated 4th August 1910, inflammable liquids are divided into two classes, the first consisting of those having a flash-point below 21° C., and the second of those with a flash-point of 21° C. or above.

Not more than 20 kilograms of the first class may be kept on private premises, and then only in closed metal vessels each containing not more than 1 litre, and marked in red on a white ground "Inflammable."

Of liquids of the second class, 30 kilograms may be kept in 5-litre vessels.

Regulations are laid down in regard to the situation and construction of "stores" for larger quantities.

No method of testing is specified.

## ROME.

### *Police Regulations.*

Inflammable liquids are divided into three classes: (a) Those having a flash-point at 760 millimetres pressure of less than 30° C.; (b) those having a flash-point between 30° C. and 100° C.; and (c) those having a flash-point above 100° C. The "Abel" test is specified. Stores are designated large, medium, and small, the quantity of each class that may be kept in each variety of store being laid down. Five litres of Class (a), 50 litres of Class (b), and 1000 cubic metres of Class (c) may be kept without a license. The distances of the stores for Classes (a) and (b) from protected works are laid down, and detailed rules made to govern the packing and transport by land and water.

## JAMAICA.

### *The Petroleum Law, 1906 (No. 37).*

All former Petroleum Laws, viz. No. 23 of 1871; No. 27 of 1882; No. 17 of 1893; and No. 22 of 1903 are repealed, except that licenses issued under a former Law shall remain in force until the expiration of the term for which they were issued, and rules made under a former Law shall be deemed to be rules issued under this Law until superseded by new rules.

Petroleum includes all hydrocarbons with a "flash-point" of 140° F. or less (Abel test). Petroleum having a "flash-point" below 95° F. may only be imported into, stored, or sold in the Island in 8-oz. bottles or in strong steel drums conspicuously marked with the name of the petroleum and with usual warning as to inflammability. Not more than 50 gallons of petroleum or 8 gallons of petroleum with a "flash-point" below 95° F. may be kept otherwise than in a building and under conditions approved by the Governor. Dealers must obtain licenses at a fee of 10s. from the Justices. In case of refusal there is a power of Appeal. Licenses are transferable. Provision is made for search, seizure, and forfeiture.

*The Petroleum Law, 1906, Amendment Law, 1907 (No. 1)*, modifies the conditions under which licenses are granted and transferred.

*The Petroleum Law, 1906, Amendment Law, 1908 (No. 37)*, brings turpentine with a "flash-point" below 90° F. under regulation, and further modifies the conditions under which licenses are granted and transferred.

By the "Oil Fuel (Landing and Storage) Law, 1915," "oil fuel" means any oil with a flash-point above 140° F., and power is given to the Governor to make regulations to govern the landing and storage of this material.

## JAPAN.

No general regulations exist, although on 15th February 1882 a proclamation was issued by which a flash-point of 86° F. (close test) was laid down, and certain simple provisions formulated. This proclamation, however, seems never to have been enforced, and at the present time it is left to the various local authorities (prefectural and metropolitan) to issue regulations to control

within their jurisdictions the storage and sale of "Kerosene." The following is a brief summary of the regulations in force in Osaka, which may be taken as typical. These were issued on 22nd May 1905, and revised in November of the same year.

### I. *General Provisions.*

"Kerosene" is defined as crude oil, semi-crude oil, and refined oil (essential oil, lamp oil, heavy oil, etc.). Class I. means that which has a flash-point (Abel) below 21° C. at 760 millimetres, and Class II. that which flashes at or above 21° C. Refinery, tank, warehouse, depôt, can-house, and shop are also defined.

### II. *Licensing.*

Any person who wishes to establish any one of the above buildings must obtain a license after stating the site and construction and the distances from other buildings, roads, rivers, etc. Provision is made for change of occupancy.

### III. *Construction and Accommodation.*

The distance to be observed from each kind of store is laid down. This varies from 5 ken (30 feet) to 20 ken (120 feet), but in special cases where proper fire-proof walls are built relief is provided. Very full specifications of the necessary method and materials to be employed in the construction of the different places of storage are given.

### IV. *Handling of Kerosene.*

This section deals with the method of carrying on business in a refinery, depôt, etc. The rules are similar to those generally obtaining in a well-ordered depôt in the United Kingdom, and are chiefly to guard against fire.

### V. *Transportation.*

Here again the regulations are for the purpose of preventing fire on carriages, ships, or boats, conveying kerosene. Every vessel carrying more than 5 "koku" must show a flag 1 foot by 2 feet with the word "Kerosene" in red, and no vessel carrying "Kerosene" may, except for loading and unloading, be moored nearer than 10 ken (60 feet) from buildings or loaded vessels.

### VI. *Inspection, Repair, etc.*

This section provides for admission of inspecting officers, repair, and alteration of buildings, and suspension of licenses.

### VII. *Penalties and Supplementary Rules.*

Any person infringing the regulations is liable to police detention or fine (amount not stated). Time is given for reconstruction of premises which are not in conformity with regulation.

It is to be noted that although a standard flash-point is laid down, the above regulations seem to apply to all descriptions of kerosene without distinction.



## TOKIO.

The police regulations of Tokio are dated April 1891. These govern petroleum refineries and places of storage, which can only be established under a police permit. Retailers may keep 30 gallons without permit. Refineries and places of storage are subject to police inspection. Apparently some test is applied, as the quantities which may be kept vary according to whether the petroleum has or has not a certificate of inspection. "Volatile oil" may not be kept by retailers. Specifications of buildings to be used for refineries or storehouses are laid down, and provision is made for preventing outflow. A further regulation was made to the effect that all existing refineries and buildings must be altered or rebuilt so as to comply with the above regulations before 31st August 1896.

## JERSEY.

The law at present in force is that of 12th February 1891. It relates to oils, mineral and vegetable essences, and allied or derived products, giving off an inflammable vapour below 73° F. (close test). A previous law, passed in 1882, affected only mineral oils and essences, such as petroleum and allied substances, the standard flashing-point being also 73° F. The limits of quantity for storage are:—In dwellings, for private use, 5 gallons, without license; or up to 50 gallons in an isolated place approved by the Constable of the parish. For sale, a license (issued for a period of twelve months without charge, by the Constable) stating the name and address of the licensee, description of store, and quantity allowed, is required, the limit of quantity in St. Helier, St. Aubin, George Town, Millbrook, Beaumont, Gorey, and Chaussée de Mont-Orgueil, being 150 gallons. For larger quantities, in these places, special permission is necessary, and precautions, to be decided upon by the Constable, must be taken for public safety. No testing instrument is mentioned. It is directed that the Constable is to apply the usual tests to ascertain the degree of inflammability. Although the law professedly refers only to substances having a flashing-point below 73° F., the storage of high-test oils, in such quantities as might constitute a public danger, is nevertheless prohibited. As in Guernsey, the arrival of cargoes of low-test oil must be notified to the Harbour Master, and none may be landed or removed at night. The Constable and Centeniers have the right to search premises and take samples for testing (on payment of their value). Penalties and confiscation are prescribed for infraction of the law.

## LABUAN.

*Ordinance No. 11 of 1882.*

Not more than 5 cases of petroleum may be kept in any place other than a dépôt authorised by the Governor. No flash-point is specified.

## MALAY STATES.

*Enactment No. 24 of 1897.*

Under this law, not more than 160 gallons of petroleum oil, if in a building 100 yards from a dwelling-house, or 32 gallons in any other building, may be kept without license. The Resident may fix the standard below which petroleum is to be regarded as dangerous, and may make rules as to the landing, conveyance, and storage of dangerous petroleum.

Provision is made for the inspection of petroleum, and for conveyance on local steam-vessels.

The Petroleum Rules, 1904, made under the above enactment, specify a flash-point of 73° F. (Abel-Pensky), and provide detailed regulations as to licensing, importation, storage, conveyance, and inspection.

#### MALTA.

*Ordinance No. 9 of 1889* provides for the testing of petroleum, the standard being the same as that prescribed by the Indian Petroleum Act, 1899, viz. 76° F. (Abel), or an average of 73°, provided no sample flashes below 70°. Notice must be given to harbour officials on the arrival of a cargo of petroleum, so that the Collector of Customs may take samples for testing. Appeal against the inspector's test is decided by a skilled person appointed by the Court. The superintendent may order the ship containing low-test oil to be removed to another port in the island, or to a distance of 1 mile from the shore.

*Ordinance No. 8 of 1897* provides that not more than 12 gallons of petroleum may be kept without a license, and that the head of the Government may make regulations as to the storage and hawking of petroleum.

#### MAURITIUS.

*Ordinances No. 10 of 1872, No. 27 of 1897, No. 54 of 1898, and No. 26 of 1905.*

The importation, selling, or keeping of all descriptions of petroleum giving off an inflammable vapour at less than 73° F. (Abel) is prohibited under penalty of fine and confiscation. Inspectors of licenses, officers of customs, and officers of municipal corporations have powers of inspection, sampling, and testing; but the owner of the oil can appeal, in which event the decision of the Government analyst, or of a competent person appointed by the magistrate, shall be final. If seizure is made, and the goods are restored to the owner, the magistrate, if of opinion that there were reasonable grounds for the seizure, shall grant a certificate to that effect, which shall be a bar to proceedings against the inspector.

The Governor has power to make regulations for the landing, conveyance, storage, and sale of petroleum.

By the Petroleum (Amendment) Ordinance, 1905, article 2 of the Principal Ordinance is amended. This refers to the sampling and testing of imported petroleum.

#### MONTSERRAT.

*Petroleum Ordinance, 1892.*

Standard of test, 83° F. (Abel). Limit of quantity to be stored, 50 gallons. All larger quantities must be kept in the Government petroleum warehouse. No low-test oil allowed to be imported, except gasoline for scientific or technical work (by permission of the Governor) and oil in 8-oz. bottles not intended for burning. Oil ascertained to be low-test, may be reshipped under certain conditions, otherwise it is liable to forfeiture. Inspectors are appointed by the Governor.

#### NATAL.

In this colony there are no Government regulations for the storage, etc., of petroleum. In Durban and Pietermaritzburg there are Municipal byelaws relating to the subject, and outside the former town the Municipal Council has

granted a piece of land for the building of petroleum stores by applicants, from which stores the places of business in the town are supplied.—DURBAN (*General Byelaws, section 43*): No person may keep or store, unless under license from the Council, more than 20 gallons of petroleum, kerosene, paraffin, or any other mineral oil, within 100 yards of any dwelling-house or warehouse, under penalty of £5 per day. The Council may authorise the searching of suspected premises, and anyone obstructing the search is liable to fine. The conditions of license are in the hands of the Council.—PIETERMARITZBURG (*General Byelaws, section 188*): No person shall keep, within the city, more than 100 gallons of petroleum oil, kerosene, or any other mineral oil, within 100 yards of any dwelling or warehouse.

NEGRI SEMBILAN—See MALAY STATES.

#### NEWFOUNDLAND.

*Inflammable Substances Act, 1916.*

“Volatile inflammable oil” is defined to include benzol and turpentine, in addition to petroleum, with a flash-point of 85° F. (Abel-Pensky) or under.

“Non-volatile inflammable oil” includes rock-oil, coal-oil, kerosene, and similar oils, and paints, varnishes, etc., containing such oils, with a flash-point above 85° F. and not above 150° F., but there is no special provision for testing these mixtures.

No oil may be imported or sold for illuminating purposes (a) if it is a volatile inflammable oil or (b) if its specific gravity exceeds 8.05. “High test” petroleum with a flash-point not less than 260° F. may be imported and sold subject to regulations as to specific gravity, and a composite high-test oil may similarly be imported and sold for outside illumination if the flash-point is 145° F. or over. Powers of entry and sampling are given to constables and Customs officers. Lubricants are exempted if marked “Non-illuminating.”

No dealer may keep more than 5 gallons of volatile oil or 5 barrels of non-volatile oil except in an “approved building,” provided that not more than 1 gallon of volatile oil may be kept in a dwelling-house and then only in an approved container.

The “proper authority,” *i.e.* the Town Council in St. John’s and the Governor in Council elsewhere, is given wide powers to make regulations.

The storage of carbide of calcium and the generation of acetylene are also regulated in this Act.

Previous Acts on the subject are repealed.

#### NEW BRUNSWICK.

The regulations in St. John are contained in the *Petroleum Storage Act, 23rd April 1890*. Two hundred and fifty gallons is the maximum quantity to be kept (in not more than 5 barrels or vessels), except in a store erected under the provisions of the Act of 34 Vict., cap. 33. It is also forbidden to allow such oil to remain on any open or uncovered piece of land for more than twenty-four hours, or longer than six days on any wharf in the city. The Chief Engineer of the Fire Department and the Engineer of the Public Safety Department are appointed inspectors of stores, with right of entry during reasonable hours.

NEW SOUTH WALES—See AUSTRALIAN COMMONWEALTH.

## NEW ZEALAND.

As far back as 1863 there was a local *Kerosene and Paraffin Oil Ordinance* for the province of Otago, amended in 1868 by the *Inflammable Oils Ordinance*. It included "kerosene" and "paraffin oil," and "benzine," without any regard to test, and limited the storage in Dunedin and other towns—otherwise than under license from the Superintendent of the Province, or in the Petroleum Warehouse—to 64 gallons in the case of dealers, and 16 gallons for private consumption, imposing penalties for infraction, of £20, and 5s. for each gallon of oil in excess of the quantity allowed, the maximum fine being £100. Three hundred gallons were allowed under license. Justices of the Peace were empowered to issue warrants for searching suspected premises, and all oil stored in contravention of the Ordinance was forfeitable.

The present regulations, which apply to the whole colony, are contained in the *Explosive and Dangerous Goods Act, 1908*, which repeals and consolidates, among others, the *Dangerous Goods Act of 1882*. The standard flashing-point (open test) is fixed at 110° F., and the directions for testing are similar to those contained in the Petroleum Act, 1871. No low-test oil may be offered for sale unless marked "Dangerous—no light to be brought near." The Governor may at any time bring oils which are not below test, under the operation of the Act, by an order in Council, applying to any portion or the whole of the colony. Vessels carrying petroleum must conform to such regulations for mooring, etc., as are made under "The Harbours Act," 1908. No "petroleum" except such as is kept solely for private use, and then only in quantities not exceeding 10 gallons, may be stored except in a public place of deposit for the same, or under license granted by the Local Authority. In such license, the conditions of storage may be prescribed. The applicant may appeal to the Minister against any refusal of the Local Authority to grant a license, or if he is dissatisfied with the conditions imposed. Inspectors are appointed by the Local Authority, and police officers are empowered to inspect oil stores during the day-time, and demand samples for testing (which must be paid for). If he appeals against the test, the Magistrates can order a retest by a competent person, the cost to follow the result. Searching suspected premises under warrant is provided for, and obstruction of inspectors is punishable by fine.

## NIGERIA (SOUTHERN).

*The Petroleum Ordinance (1889).*

The amount to be stored for use or sale is limited to 10 gallons, except under license, the conditions of which are to be determined by Rules issued by the Governor. No Rules were issued until 1911, so that up to that time no petroleum could be kept except in a Government warehouse. The Rules now in force are somewhat restrictive, as they apply to all petroleum, whatever the flash-point may be. Licenses are granted by the Collector of Customs at a fee of 5s. There are the usual regulations as to mooring and unloading vessels; appeal against refusal to grant license; power of search and penalty for opposing same. No standard of test is prescribed.

## NORTH BORNEO.

The *Explosive and Combustible Substance Storage Proclamation, 1884*, limits the amount of petroleum to be kept in any *attap* tenement, to 12 *catties*<sup>1</sup> (and

<sup>1</sup> A *catty* = 1.3948 lbs. avoirdupois.

that for private consumption only), and in any other building or place, 1 tin of 25 *catties*, except under special permit, from the Resident, in the town of Sandakan, and from the Governor elsewhere, stating the amount allowed to be stored. The Governor may also make regulations for depôts, and authorise charges for storage. A permit is required before removal from any place or vessel to any other place or vessel. There is no standard of test.

## NORWAY.

In 1871, a legislative enactment (dated 3rd May) provided regulations for the storage of petroleum and its products. The liquids were divided into two classes, according to their degree of inflammability. Under Class A were included ether, photogen, camphine, benzine, "gas ether," carbon disulphide, petroleum naphtha, petroleum spirit, and all petroleum and turpentine products giving off an inflammable vapour below 35° C. Class B consisted of such mineral oils, etc., as have a flashing-point not below 35° C. The erection and carrying on of refineries for inflammable liquids was only permitted outside the boundaries of towns and at a minimum distance of 400 feet therefrom, and it was required that there should be a minimum distance of 200 feet between a refinery and the nearest building. The prevention of outflow of dangerous liquids was also insisted on. Crude and refined petroleum, and crude paraffin oil, were placed on the same footing as regarded restrictions in respect to storage, but chemists were allowed to keep up to 3 gallons of crude oil, in vessels holding at most three-quarters of a gallon. The quantity to be stored in any one building was limited to 30 gallons of liquids of Class A and 200 gallons of liquids of Class B. Larger quantities (up to 2500 gallons of Class A and 125 gallons of Class B) were allowed to be stored in underground cellars, sufficiently large to prevent outflow, made of fireproof materials, with iron doors, and well ventilated. Ships carrying passengers were not allowed to have more than 15 gallons of liquids of Class A on board. For the unloading of ships and the transport of crude oil, notice to the police was necessary. The fixing of the standard of test and mode of testing was vested in the King.

In 1879 a fire-test (of 120° F.) was substituted for the flash-test, but no instrument for determining the fire-test was ever prescribed by the King, and it was not until 1890 that a definite standard was introduced. By the law of 14th June of that year, 22° C. (Abel), at a barometric pressure of 760 millimetres, is fixed as the minimum flashing-point for liquids of Class B, all flashing at a lower temperature being included in Class A. The quantities now allowed to be stored in one building or store-ship, are:—

Class A.—360 litres, in vessels marked "Dangerous," and holding not more than 15 litres each.

Class B.—800 litres; or larger quantities under special permit.

Stores are to be at a distance of 125 metres from the boundaries of towns. It is forbidden to transfer liquids of Class A from one vessel to another within town boundaries, and persons dealing in or wishing to land liquids of this class must notify the police.

A law in regard to inflammable articles came into force in May 1909, of which Section 16, sub-sections 7–10, deal with petroleum. The only alteration, however, seems to be that in Class A the vessels may each contain 40 litres instead of 15.

## PORTUGAL.

*Decree of 21st October 1863.*

The storage, in dépôt, of more than 50 kilograms of inflammable liquids (alcoholic and ethereal liquids, spirits of turpentine, petroleum, etc.), and, in cities, the storage of such liquids in any place where drugs and other articles are also kept, is subject to the supervision of the police.

There are no fixed regulations relating to storage, but the administrative authorities, after consultation with experts, may impose such restrictions as they may think fit. The *Preliminary Instructions of the General Customs Tariff, 14th December 1882 (11th paragraph of Art. 14 and Schedule C)*, provide that all mineral oils and spirits may only be landed at special quays, whence they are conveyed to the stores. There has been no legislation on the subject since the above dates.

QUEENSLAND—See AUSTRALIAN COMMONWEALTH.

## RUMANIA.

There are no restrictions on the storage, conveyance, and sale of petroleum. The standard flash-point is 23° C. (Abel-Pensky) for refined petroleum and 0° C. for crude oil. Petroleum above standard flash-point is exempt from all legislative restriction.

## RUSSIA.

*Decree of 11th June 1891. (Amended.)*

The regulations do not apply to ostatki (fuel petroleum) or lubricating oils. Petroleum is divided into two classes—Class I. having a flash-point above, and Class II. a flash-point below, 28° C. (82·4° F.) Abel-Pensky. The Government may, however, raise the flash-point on good cause being shown.

Petroleum may not be sold before it has been inspected.

Petroleum spirit of Class II. may not be conveyed in bulk, but must be contained in strong metal or glass vessels or in iron-hooped barrels. Provision is made for inspection and testing. A technical committee is appointed at Baku to deal with all matters connected with the testing of petroleum, and to collect statistics of production.

Petroleum stores are to be licensed by the Local Authority and to be inspected by the police. The quantities to be kept in large stores are unlimited. In medium stores 900,000 lbs. of either class may be kept, and in small stores 43,000 lbs. of Class I. and 2200 lbs. of Class II. The two classes may not be stored in the same building, unless they are separated by a fireproof wall. Large and medium stores must be outside towns and villages, and distant from the boundaries of adjacent properties not less than 115 and 70 feet respectively. Small stores must be at a distance of not less than 49 feet from dwelling-houses. Permission to reduce these distances may be given in special cases. Dwelling-houses, smithies, etc., in connection with stores, must be at not less than 115, 70, and 49 feet from large, medium, and small stores respectively. Chemists and chandlers may be licensed to retail petroleum; the former may keep 1100 lbs. of Class I. and 360 lbs. of Class II., and the latter only 540 lbs. of Class I.

Regulations as to the construction and management of petroleum stores, and as to the storage of empty barrels, were confirmed on 7th September 1891.

*The Mining of Petroleum.*

Prospecting for petroleum by private individuals of all classes is allowed subject to certain conditions as to ownership of the land, whether private or Government, a chief provision being that the land in question may not be used by the prospector for any other purpose. When Government land is covered by valuable forests, special regulations for their protection are prescribed. Land granted in private freehold by Imperial gift for petroleum exploitation remains the property of the Government. Foreigners and Jews are forbidden unlimited powers of attorney in certain cases. The discovery of petroleum must be notified to the local mining authority and certain information given. Mining work is subject to supervision by the Government Mining Engineer, who is also responsible for the observance of all regulations. Provision is made for the hearing of complaints and for discussion of the best means of preserving the oil-fields.

Exploiters pay a special rate of one-fiftieth to one-twentieth of a copeck per pood for the purpose of providing necessary appliances, roads, medical assistance, and other general requirements. All doubtful matters are settled by the Minister of State Domains.

General prospecting without excavation work is allowed on Government land without restriction, but if it is desired to commence excavation, the prospector must (1) mark the locality by erecting a post with his initials and the date carved on it, and (2) furnish particulars to the local Administrator of State Domains. Permissive certificates for prospecting are issued for one year, and give exclusive prospecting rights over an area of 90,000 square sajens, calculated from the prospector's post as centre. A payment not exceeding 5 roubles per desiatine is required.

A prospector wishing to produce petroleum on a prospected area must apply for the allotment of a plot within the area. This is surveyed by an official, and the remainder of the area must be surrendered within two months. For the use of this plot the exploiter pays a tax per desiatine as fixed by the Minister for twelve years in advance. If this is allowed to become in arrear, the plot may be sold by auction, or, if no purchaser appears, may be taken over by the Government. The exploiter must start work within two years.

Prospecting on proved Government land is forbidden. Plots of such land are sold by auction under specified conditions, or privately if there are no bidders.

Detailed rules are laid down to ensure mutual assistance and protection as between neighbouring exploiters, the District Engineer being the arbitrator. This official also determines the steps to be taken to safeguard the various borings and wells, and to deal with petroleum fountains.

Provision is made for laying local pipe-lines, free grants of land for the purpose being given subject to the rights of private owners.

The above is abstracted from a work entitled *Extracts from the Russian Law on Mining*, issued for private circulation only by Mr James Wishaw of Petrograd.

## ST. CHRISTOPHER AND NEVIS.

*The Petroleum and Explosives Ordinance, 1909.*

All previous legislation is repealed by a Schedule. "Volatile petroleum" is defined as having a flash-point below 83° F. (Abel). Notice must be given on importation of any petroleum, and the same must be deposited in a Government store until tested. If then found to be "volatile petroleum," it is liable

to seizure and forfeiture, otherwise it is released for distribution. Petroleum in close glass bottles of 8 ozs. each, not to be used for burning; petroleum for use as fuel for oil engines (subject to regulations); and gasoline for scientific work, are exempted. Not more than 80 gallons of petroleum may be kept in one place, except in a licensed warehouse. Provision is made for seizure and forfeiture.

#### SAINT LUCIA.

*Petroleum Ordinances, 1900 and 1903.*

“Volatile petroleum” is defined as having a flash-point below 95° F. (Abel), and may not be imported except in glass bottles containing not more than 12 ounces. No oil is allowed to be sold except under license, to be obtained from the Stipendiary Justices. The Governor may grant a license after the refusal of the Justices. Limits of quantity to be stored:—On private premises for consumption, 10 gallons; in licensed stores, 100 gallons. For larger quantities, stores must be provided under regulations made by the Governor. Appeal against the inspector’s test may be made to the Governor. The Governor may make regulations as to the landing and storage of petroleum oil.

#### ST. VINCENT.

*The Explosives and Petroleum Ordinances, 1910.*

Petroleum is defined as in the British Act, the limit of “dangerous” petroleum being fixed at 83° F. (Abel-Pensky). Notice must be given before importing “dangerous” petroleum. A license, without fee, is required for the keeping or use of “dangerous” petroleum, a bond, in a sum of £50 that the regulations will be observed, being deposited with the Treasurer if required. No “dangerous” petroleum for sale shall be kept in a shop, but only in a Government petroleum store or approved building, and such petroleum shall only be sold to licensed persons in conspicuously marked metal cases. No person may keep more than 50 gallons of petroleum, nor more than 20 gallons of “dangerous” petroleum, except in a Government store, but “dangerous” petroleum not exceeding 20 gallons may be kept by a licensed person in an isolated building not less than 20 feet from a dwelling-house, shop, factory, etc., and under regulations by the Governor. Power of appeal is given, and provision made for inspection and sampling; also for entry by search warrant, seizure, and forfeiture. Government petroleum and petroleum (not used for burning) up to 12 ozs. in close glass bottles exempted.

Regulations under Section 15 of the above Ordinance were issued by the Governor in April 1910.

SELANGOR—See MALAY STATES.

#### SEYCHELLES.

*The Dangerous Goods Ordinance, 1911.*

Power is given to the Governor to make regulations as to the conditions under which dangerous goods may be imported, kept, and tested. Provision is made for inspection, search, and forfeiture. “Dangerous goods” are those specified in a schedule to the regulations, and include other materials besides petroleum. Petroleum spirit or petrol is that which has a flash-point of less than 90° F. when tested in the “tester” deposited with the Customs. One litre of petrol or 180 litres of oil may be kept in any licensed shop or store, and



half a litre of petrol or 72 litres of oil in a private house. Special provision is made for keeping petrol for use in machinery on land or water. In stores specially licensed by the Governor on approved sites not less than 15 metres from a building, 100 litres of petrol may be kept.

Ordinances No. 6 of 1896, No. 9 of 1907, and No. 9 of 1908 are repealed.

#### SIERRA LEONE.

*The Petroleum Ordinance, 1906 and (Amendment) 1907.*

Petroleum is defined as in the English Act of 1871. The standard is 95° F. (Abel), and no petroleum of lower flash-point may be imported or kept for illuminating purposes. By the Amending Ordinance of 1907, however, the Governor in Council may grant a permit for the importation or keeping of low-flash petroleum for other purposes subject to conditions, and if it is to be used for industrial or manufacturing purposes, he may remit the duties payable on importation. Notice of importation must be given. Not more than 10 gallons of petroleum may be kept except under license. Licenses are of three classes: (a) Unlimited, (b) not exceeding 100 gallons, (c) not exceeding 20 gallons; and "Hawkers'" licenses are also issued. There is a power of appeal in case of the refusal of a license. Provision is made for sampling, search, seizure, and forfeiture. The Governor in Council may apply the Petroleum Ordinances to any substance, subject to certain conditions, and may make rules and regulations for the better administration of these Ordinances.

SINGAPORE—See STRAITS SETTLEMENTS.

SOUTH AUSTRALIA—See AUSTRALIAN COMMONWEALTH.

#### SPAIN.

There is no general law as to the storage, etc., of mineral oil and spirit. The manufacture and storage of these articles (together with explosives and articles of an inflammable character) are regulated by municipal byelaws, of which those in force in Madrid are said to afford a fair example. The Madrid byelaws do not mention mineral oil or spirit, but they specify fireworks, gunpowder, phosphorus, pitch, tar, resin, gum, and brandy, and they provide that these substances and all other inflammable articles (presumably including mineral oil and spirit) may be kept only under license, in vaulted and properly constructed cellars, and in quantities not exceeding a month's sale. Stores for large quantities, and for wood, coal, firewood, and straw, and similar materials burning easily, shall be situated, "if possible," in isolated places and out of the town, and the premises must be licensed. Insurance companies may inform against any infraction. The stores may not be entered during the night, even with a properly closed lamp, and no smoking or artificial light is allowed in stores where brandy, coal, straw, or phosphorus are kept.

#### STRAITS SETTLEMENTS.

*Petroleum Ordinances, 1908 and 1909.*

*Petroleum Revenue Ordinance, 1909.*

"Dangerous petroleum" is defined as having a flash-point below 73° F. (Abel-Pensky). Regulations are made to govern import and export of all kinds of petroleum with a flash-point at or below 150° F. when tested in the manner

prescribed. Petroleum flashing above 150° F. is not subject to any legislative restrictions. The method of carrying petroleum on ships as deck cargo or otherwise is regulated. Not more than 240 gallons of "dangerous petroleum" may be carried on a local steamship as deck cargo. The local conveyance of petroleum and dangerous petroleum is regulated, but that carried in tanks or vehicles is exempt.

Without a license no person may keep any dangerous petroleum, nor more than 40 gallons of petroleum, within 100 feet of a building; otherwise the limit is 64 gallons and 160 gallons respectively. The Governor may delegate other persons to grant licenses subject to a right of appeal.

Provision is made for inspection and search; also for applying these ordinances to any other inflammable liquid. Extensive power of making rules is given to the Governor in Council, and to the Commissioners of Municipalities and Rural Boards.

Under the above power the Commissioners of Singapore, Penang, and Malacca have issued very comprehensive byelaws; as have also the Rural Boards.

The Petroleum Revenue Ordinance, 1909, consists of 43 sections, and regulates the keeping of "dutiable petroleum" in bond and the payment of the duty. Provision is also made for search, seizure, and forfeiture.

#### SWEDEN.

*Laws of 26th November 1875, and 27th March 1885.*

The inflammable liquids affected by these regulations are divided into two classes. Class I. comprises the more inflammable—such as benzene, ligroin, petroleum, naphtha, crude paraffin oil, crude wood spirit, etc., giving off an inflammable vapour below 22° C. (=71.6° F.) Abel test. Class II. includes all the less inflammable—viz. refined petroleum, refined paraffin oil, astral oil, refined wood spirit, turpentine, lubricating oils, etc., flashing between 22° and 40° C. (=104° F.) Abel test.<sup>1</sup> Refineries must be at least 500 feet (about 487 feet English) from the boundary of a town, or from any other building, unless by special permission. Plans of the works must be submitted to the authorities, and the premises inspected, before refining is begun. Provision must be made for the prevention of outflow or drainage of oil into other properties or into canals, lakes, etc., and all oils must be removed from the premises as soon as ready for market.

*Storage.*—Both the wholesale and retail stores are subdivided into two classes. *Smaller wholesale stores* are for quantities of 2000 to 35,000 *kannor* (1152 to 20,160 gallons)—or, with special permission, 70,000 *kannor* (40,320 gallons)—not more than 7000 *kannor* of which shall be of liquids of Class I., but such stores must not be in a closely built or inhabited part of a town, nor under a building used for any other purpose. *Larger wholesale stores* are not subject to any restriction as to quantity, but cannot be established without special permission. The limits of distance from other buildings, etc., and prohibition of risk of outflow, are the same as for refineries. Every wholesale store is required to be well ventilated, and to contain an excavation, kept free from water, and large enough to hold one-fourth more than the entire quantity stored. If within the 500-foot limit and above ground, the store must be built

<sup>1</sup> The standard flashing-points mentioned were fixed in 1885. Previously the standards were—  
For Class I., 35° C. (= 96° F.).  
.. .. II., 80° C. (=176° F.).

with fireproof brick, or iron walls with iron doors and windows. No smoking, matches, or lights are allowed, and work may only be carried on during daylight. No part of the store may be used as a dwelling-place at night. Sand must be provided in case of fire. Only iron barrels or wooden casks with iron hoops may be stored, and these must be so arranged as to admit of ready inspection. No more empties are allowed to be kept than are absolutely necessary. *Small retail stores.*—Permission is granted on giving notice. Limit, 300 *kannor* (about 173 gallons), of which not more than 30 *kannor* (about 17 gallons) may be of liquids of Class I. Stock to be kept in 10-gallon (maximum) iron casks, or 3-gallon glass or stone bottles. *Large retail stores.*—Permission is granted after inspection and approval of premises. Limit of quantity, 2000 *kannor* (1152 gallons), including a maximum of 400 *kannor* (about 230 gallons) of liquids of Class I. Precautions must be taken against fire, and the authorities may prescribe additional regulations. *Private houses.*—Limit of quantity, 20 *kannor* in towns or 100 *kannor* in the country. A sufficient number of inspectors shall be appointed by the head of the Civil Department of the Government, each inspector to be provided with an Abel tester, and to keep a record of all tests.

A Royal Ordinance was issued on 20th January 1911 amending paragraph 23, section 3, of the Decree of 26th November 1875, so as to allow steam ferries by which direct railway communication with foreign countries is maintained to carry inflammable liquids of the second class on condition that they are carried in tank wagons of approved construction and so placed on the steam ferry that they can easily be thrown overboard.

A further decree was issued on 21st May 1910 amending paragraphs 23 and 32 of the Ordinance of 26th November 1875 in regard to the loading of inflammable liquids on ships. The new regulations are very similar to the usual harbour byelaws in the United Kingdom governing the unloading of petroleum spirit, but in a vessel carrying passengers liquids of the first class must be in metal barrels only, and not more than a limited quantity of either class may be carried.

It would appear that the issue of a new Ordinance is contemplated.

#### SWITZERLAND.

On 29th January 1909 an Ordinance was issued in pursuance of the Federal Law of 8th December 1905 concerning "the traffic in foodstuffs and various materials in common use," under which all legislation in regard to petroleum passed out of the hands of the Cantonal Authorities and was taken over by the Federal Government. Apparently, however, the only regulation issued is to the effect that all petroleum used for lighting, cooking, and heating must have a flash-point of at least 23° C. (73°·4 F.) Abel; and that all petroleum sold under the designation "safety petroleum" must have a flash-point of at least 38° C. (100°·4 F.) Abel. As, however, there are presumably other regulations in existence, and as it is impossible that these remain in force in the different cantons until superseded by a Federal enactment, the regulations issued prior to the above date by some of the Cantonal Authorities are given below.

#### APPENZELL—RHODES EXTÉRIEURES.

*Regulations of 30th April 1893.*

The entire traffic in petroleum, benzine, ether, turps, neolin, ligroin, alcoholic or turpentine varnishes, alcohol in large quantities, and in other dangerously inflammable substances, as well as the distillation of oils, comes

under the supervision of the fire police. Delivery of these materials may only be made in daylight. The quantities which may be kept otherwise than in stores are limited, being 25 kilograms of petroleum spirit and 5 barrels or 750 kilograms of petroleum oil. Stores must be outside villages, and at least 30 metres from roads, railways, public places, etc. In all cases, provision must be made against outflow, and sand for extinguishing fire must be kept. Smoking is prohibited, and stores may not be entered at night. Safety-lamps must be used for dark places. In shops, not more than 100 kilograms of oil and 10 kilograms of spirit may be kept, and must be contained in metal vessels fitted with brass taps and drip-pans. Petroleum cooking-stoves must be constructed so that all parts can be easily cleaned, and must stand on trays. Their wicks must be enclosed in tightly-fitting wick-tubes; they must be filled by daylight at a safe distance from a fire.

#### APPENZELL—RHODES INTÉRIEURES.

*Regulations of 18th January 1894.*

Sellers of petroleum, ligroïn, alcohol, and dangerously inflammable substances must have a special police license. Not more than 2 barrels of petroleum may be kept by dealers. Ligroïn in small quantities must be kept in metal bottles; large quantities must be kept in vaulted rooms. Sand must be provided, and sale may only take place during daylight.

#### CANTON OF BERNE.

*Ordinance of 29th July 1907.*

This Ordinance governs the storage, sale, and use of inflammable and explosive substances employed for industrial, professional, or domestic purposes, or for driving motor vehicles, such as petroleum, mineral spirits (petroleum ether, ligroïn, neolin, benzene, naphtha, gasoline, etc.), ether, turps, carbon disulphide, phosphorus, alcohol, varnishes, and other substances liable to cause fires, but it does not apply to explosives ordinarily so-called nor to compressed gases, carbide of calcium and acetylene, which are otherwise regulated. The sale of any of the substances to which the Ordinance applies is prohibited without registration with the local police. Sale or transfer from one vessel to another may only take place during daylight except that spirits of wine and petroleum may be sold in closed receptacles after dark. Chemists' shops are also exempted. Vessels containing any of the proscribed substances may not be left at night in public places or highways.

Specified quantities of each of these substances may be kept (1) in dépôts suitably constructed and not less than 30 metres from any other building, (2) in iron or cement reservoirs, (3) in other places of fireproof construction, (4) in ordinary non-fireproof buildings such as shops and dwelling-houses.

No petroleum may be sold for lighting purposes unless its flash-point is at least 23° C. (Abel) nor as "safety oil" unless its flash-point is above 38° C., and lamps may be filled by daylight only. The police must inspect all registered premises at least once a year.

An amending Ordinance dated 23rd October 1907, provides for the storage of motor spirit for use in motor vehicles and boats. According to the situation and construction of the place of storage the maximum quantity kept may be 150 or 600 kilograms. Every receptacle must be fitted with an approved safety device. Naked lights and smoking are prohibited; oily cleaning cloths must be kept in a closed iron box; tanks may only be filled during daylight, and notices to this effect must be posted.

## GENEVA.

*Regulations for Inflammable Liquids, 1903.*

Petroleum oil is distinguished from essences of petroleum and from benzene distilled from coal. Petroleum oil above 10 kilograms and petroleum spirit above 1 kilogram in weight may not be kept, conveyed, or sold without a license. In a dwelling-house there may be kept, under license, 1100 kilograms of inflammable liquids, and in a building near a dwelling-house, 1600 kilograms. Of these quantities, not less than 600 kilograms must be petroleum oil. Metal vessels only must be used, and must conform with specified requirements.

## LUCERNE.

*Fire Police Law of 4th December 1903.*

The quantity of petroleum spirit allowed to be kept by a retailer is 50 kilograms, and in a shop, 20 kilograms. It is prohibited to pour petroleum on a fire. Provision is made as to sampling. Empty petroleum barrels may not be stored close to inhabited buildings. Petroleum spirit may not be used for indoor lighting. Full regulations are included for petroleum motors installed in buildings, but future motors are to be constructed for oil and not spirit. In other respects these regulations agree with those of Appenzell (Rhodes Extérieures). See above.

## ZURICH.

*Regulations of 27th March 1898, and 27th March 1899.*

These regulations closely resemble those of Lucerne (above), with the exception that in shops the quantities allowed are 150 kilograms of oil and 25 kilograms of spirit, and that private users must obtain police permission to keep more than 10 kilograms of oil and 2 kilograms of spirit.

## TASMANIA—See AUSTRALIAN COMMONWEALTH.

## TRINIDAD AND TOBAGO.

*The Petroleum Ordinance, 1915.*

“Petroleum” is defined as rock oil, etc., having a flash-point of 95° F. (Abel) or higher, with power of exemption by the Governor; “Dangerous petroleum” as having a flash-point below 95° F. (Abel). “Crude petroleum” is also defined.

Vessels carrying petroleum must, while in a harbour, conform to the Harbour Master's regulations. No crude or dangerous petroleum nor more than 5 gallons of petroleum may be delivered or received except between the hours of 7 a.m. and 6 p.m. No person within the limits of the town of Port-of-Spain, the Boroughs of San Fernando and Arima, and other prescribed places, may keep more than 10 gallons of petroleum or 1 gallon of dangerous petroleum except in a licensed magazine; and no petroleum may be kept for sale in the above places except under license by the Inspector of Mines. No dangerous or crude petroleum may be kept for sale anywhere except under license, and may only be delivered from a magazine to a licensed user. Licenses to use are issued subject to prescribed conditions. Not more than 100 gallons of petroleum may be kept in these places, except with the permission of the Inspector

of Mines. In case of refusal of license there is a power of appeal to the Governor. Facilities are given for the use of petroleum in gas-making machines, and provision is made for inspection, search, and testing.

The Governor may issue regulations dealing with the testing, storage, transport, and conveyance by pipe-line of all kinds of petroleum, and fixing the fees payable.

An "informer," not being the servant of the person informed against, may be awarded half of any penalty recovered under this Ordinance.

The Petroleum Ordinance, 1909, is repealed.

The Petroleum Spirit and Petroleum Oil Excise Ordinance, 1914, with its amendments in 1915, 1916, and 1917, establishes a duty of fourpence per gallon on all oil or spirit manufactured and delivered for consumption in the Colony, and provides for the issue of licenses to manufacture.

#### TURKEY.

By regulations issued in December 1906 storage depôts for petroleum are to be established by Local Authorities outside towns and villages, and no trader may keep on his premises more than he actually requires for use; a small fee is charged for storage in the depôts, but private stores already established may be used on existing terms. Private depôts may be established subject to conditions as to site and construction, and to supervision by Local Authorities. There are no testing regulations.

#### UNITED STATES.

*Note.*—All temperatures under this heading are in degrees Fahrenheit.

ALABAMA.—*Storage.*—There is no State law referring to petroleum products. *Test.*—120° fire; Tagliabue cup.

CITY OF MOBILE.—The storage of petroleum and other inflammable liquids is under the control of the Fire Police Department.

ARIZONA.—No State law relative to petroleum.

ARKANSAS.—*Storage.*—No State regulations. *Test.*—150° fire; Tagliabue cup.

CALIFORNIA.—No State law on petroleum. *Test.*—110° flash; Tagliabue open cup.

CITY OF LOS ANGELES (1883).—*Storage.*—Except in one specified district (District No. 3 of the general fire limits of the city) not more than 150 gallons of any petroleum product other than refined petroleum (for which the limit is 200 gallons in metal cases) may be kept, and this must be stored in iron tanks. No license necessary. *Test.*—110° flash; Tagliabue open cup.

CITY OF SACRAMENTO.—*Storage.*—Same as San Francisco (*q.v.*). *Test.*—110° flash; Tagliabue open cup.

CITY OF SAN FRANCISCO.—*Storage.*—For quantities in excess of 100 gallons of spirit or 1000 gallons of oil (both in metal cases) an annual license must be taken out, and the stores must be brick buildings not over one story high, used for no other purpose, and approved by the fire marshal and majority of the fire department. *Test.*—100° flash; Tagliabue open cup.

CAROLINA.—See NORTH CAROLINA and SOUTH CAROLINA.

COLORADO.—The power of making petroleum regulations is vested in mayors and councils of cities and towns. *Test.*—90° flash; Foster closed cup.

CITY OF DENVER.—*Storage.*—A permit from the mayor is necessary in the

case of storage of more than 3 gallons of mineral spirit or 5 barrels of refined petroleum within the city limits. *Test.*—110° flash; Tagliabue open cup.

CONNECTICUT.—No State law affecting storage. *Test.*—110° flash; 140° fire; Tagliabue open cup.

CITY OF MERIDEN.—*Storage.*—Annual license. Limit, 3 barrels in any inhabited building, or 10 barrels in cellars 4 feet below ground level, and not under a dwelling. *Test.*—125° fire.

CITY OF NEW HAVEN.—*Storage.*—Permit or license required for quantities exceeding 1 barrel of refined oil. Up to 3 barrels, a permit from the fire marshal is sufficient. Beyond this amount, and up to 30 barrels, storage is allowed, under Corporation license, in cellars 5 feet below the ground, or with a raised sill of 3 feet of masonry (with a limit of 10 gallons in the case of spirit). For larger quantities, special provisions are requisite. No refinery may be erected within 300 feet of any building, wharf, bridge, or body of water communicating with New Haven harbour. *Test.*—110° fire; Tagliabue cup.

DAKOTA.—See NORTH DAKOTA and SOUTH DAKOTA.

DELAWARE.—*Test.*—115° fire; Tagliabue cup.

CITY OF WILMINGTON.—In certain defined districts of the city, only as much as 5 barrels may be stored; but outside these localities an unlimited quantity may be kept, provided that the place of storage is at a minimum distance of 100 feet from any dwelling. *Test.*—110° fire.

DISTRICT OF COLUMBIA.—The Commissioners of the District of Columbia have no regulation in effect governing the test of kerosene oil sold within the District.

FLORIDA.—No State law relative to petroleum.

GEORGIA.—*Test.*—140° flash; Elliott cup.

CITY OF SAVANNAH (1881).—*Storage.*—Up to 250 gallons may be kept in any building without a license; or an unlimited quantity in specially adapted detached buildings (not occupied as dwellings), constructed so as to prevent outflow, and either situated at least 50 feet distant from any other building, or separated therefrom by a wall 10 feet high and 12 inches thick. Licenses are granted to store on other premises, except wharves and dwellings, or rooms above the ground-floor, provided the parting walls and all doors are fireproof.

IDAHO.—120° fire; Tagliabue cup.

ILLINOIS.—*Storage.*—No State law. *Inspection* (State Law, 1st July 1877).—The appointment of testing inspectors in towns and villages is compulsory on the requisition of more than five inhabitants. Inspectors must brand all casks, etc., tested with "Approved fire test . . ." if the oil passes the test, otherwise with "Condemned for illuminating purposes, fire test being . . ." A record of tests must be kept, and this is to be open to inspection. Producers of or dealers in oils must give notice to the inspector within two days after oil is made, refined, or received. Omission to do this; selling untested or low-test oil; counterfeiting brands; or using branded vessels for untested oils—is punishable by fines and forfeiture of the oil, as well as liability for damages to anyone injured. Inspectors may not trade in oils, and are liable to dismissal, fine, and damages for any injuries resulting from any fraud or negligence, of which they may be guilty. *Test.*—150° fire; Tagliabue cup, or other approved instrument.

CITY OF CHICAGO.—*Storage.*—The limit of quantity which may be kept without license is 5 barrels of mineral spirit or turpentine, of which not more than 1 barrel may be stored elsewhere than in a cellar 5 feet below the level of the street. The 1-barrel limit elsewhere than in a cellar, applies also to refined petroleum. Unlimited quantities may be stored—subject to license from the

Corporation—in detached fireproof warehouses exclusively used for inflammable liquids, provided that these are properly ventilated, situated at least 50 feet from other buildings, and have cellars at least 3 feet below the ground floor. The walls must be at least 16 inches thick, and not exceed 16 feet in height; the floors must be made fireproof, and the roofs of iron or composition. The surrounding fire-walls are to be of specified height and thickness, and the copings of incombustible material.

**CITY OF PEORIA.**—*Storage.*—Retailers may store up to 2 barrels outside the fire limits without license. Larger quantities must be kept in specially constructed buildings or closed tanks, at least 40 feet from other buildings, and by special permission, as to amount, from the chief of the fire brigade and the city council. The principal details of construction of these buildings and tanks are, that the former must have walls of masonry of a minimum thickness of 16 inches, and a maximum height of 18 feet, and the tanks are not to exceed 20 feet in height or diameter. The latter are to be fitted with automatic safety-valves, to stand 30 feet apart, and to be contained in wall enclosures of at least three-quarters the capacity of the tanks.

**INDIANA.**—*Test.*—120° flash; 140° fire; Tagliabue open cup. *Storage.*—No State law. The local regulations in all the chief cities are similar to those of Philadelphia (*q.v.*).

**INDIAN TERRITORY.**—No State law on petroleum.

**IOWA.**—*Test.*—100° flash; Elliott cup. *Storage.*—No State law. *Inspection.*—The appointment of inspectors and deputy inspectors to test the oil is compulsory. The provisions are similar to those in force in Wisconsin (*q.v.*).

**KANSAS.**—(Law, 18th March 1889).—*Inspection.*—Appointment of inspectors is provided for, as in Illinois. Inspector must give bond for proper discharge of duties; and brand standard test oils—"Approved, fire test being 110°"; and low-test oils:—"Condemned for illuminating purposes, fire test being below 110°"; together with name and date. Inspector may appoint deputies, for whom he is responsible, but may not deal in oils. He must keep a record of tests, open for inspection. In case of fraud, or culpable negligence in discharging his duties, an inspector is liable to fine and imprisonment. Selling low-test or untested oil; falsification of brands; omission to give notice to inspector of possession of untested oil within two days after same is made or received; or using branded vessels for untested oil, is punishable by fine and confiscation of the oil. *Test.*—110° flash; Foster cup. *Storage.*—No State law.

**CITY OF TOPEKA.**—The storage of quantities exceeding 5 barrels is subject to permission by the fire marshal, who regulates the construction of stores and is required to regularly inspect them.

**KENTUCKY.**—*Storage.*—No regulations. *Test*<sup>1</sup> (Law of 21st February 1874).—130° fire; Tagliabue cup. Oils passing the test are to be branded "Standard oil," and all others are to be marked "Unsafe for illuminating purposes." The selling of uninspected or low-test oil, or the hindering of inspectors in the discharge of their duties, is punishable by fines. By the Law of 8th February 1876, inspectors are appointed for four years. *Regulations for applying Fire Test* (Law of 21st February 1874).—Water cup must contain sufficient water to reach two-thirds of the way up the side of the oil cup, which is to be filled with oil to within  $\frac{1}{8}$  inch of the top. If the oil does not ignite without heating when a lighted match is applied to its surface, an alcohol lamp is used to raise its temperature, and is so regulated that the temperature of oil increases between 1° and 2° (minimum and maximum limits) per minute,

<sup>1</sup> See *General State Laws*, J. B. Sanborn, 1878, chap. cxxii.



as indicated by a thermometer, the bulb of which is just covered by the oil. At each degree, a lighted match is passed over the surface of the oil at a distance of  $\frac{3}{8}$  inch, and as soon as the oil flashes the lamp is removed. If it does not continue to burn, the test is continued as before until ignition takes place.

**CITY OF LOUISVILLE.**—The General Council has power to introduce storage regulations, but does not appear to have acted upon it.

**LOUISIANA.**—*Storage.*—There is no State law on this head. *Inspection* (Law of 2nd April 1877).—Inspectors must test, gauge, and mark each barrel, and deliver a certificate to the owner, taking a duplicate for the Board of Health. This does not apply to oil for delivery outside the State, which must be so branded by the seller. No untested oil or naphtha may be sold, and if sold, the seller is debarred from any suit at law to recover price of same from the purchaser. Low-test oil must be marked “explosive and dangerous,” failing which the seller, besides being liable to penalty, is also liable in damages and costs, for injury to persons or property caused by explosion or ignition of such oil, except in case of gross negligence or carelessness. *Test.*—125° flash; Tagliabue or other approved instrument.

**CITY OF NEW ORLEANS.**—*Test.*—110° fire; Tagliabue cup. *Storage.*—The quantity of oil that may be stored in one building is limited to 5 barrels (or the equivalent), and it must be contained in metallic packages.

**MAINE.**—*Storage.*—No law. *Test.*—120° fire; Tagliabue cup.

**CITY OF PORTLAND (1883).**—A license is required for quantities exceeding 100 gallons, but may not be granted for storage at wharves or on inhabited premises, or for storage above the first floor of any building, or for keeping spirit elsewhere than in cellars, unless contained in well-closed metal vessels. Neither may more than 100 gallons of any petroleum product be kept on the first floor, unless contained in tightly-closed metal vessels, and the foundations and walls of the building are of stone, brick, or iron, and the walls built without apertures for at least 1 foot above the floor. The Corporation has power to revoke licenses at pleasure.

**MARYLAND.**—*Storage.*—No State law relating to petroleum. *Test.*—110° fire; Tagliabue cup.

**CITY OF BALTIMORE.**—*Storage.*—A license is required, and a special Corporation license for quantities exceeding 100 barrels, but with regard to the actual quantities permitted, the terms of the ordinance are somewhat conflicting. In one place it limits the amount to 1 barrel, in metallic packages, in buildings other than dwelling-houses; but in another it states that oil for illuminating purposes may be kept on sale in stores, dwelling-houses, or other building (apparently in unlimited quantities). Spirit is limited to 15 gallons in one building. Refineries must be at least 50 feet from other buildings, or 100 feet if the refineries are frame buildings. *Test.*—120° flash.

**MASSACHUSETTS.**—*Storage.*—Petroleum, in unlimited quantity, may be stored without license, in detached “specially adapted” buildings, surrounded by an embankment to prevent outflow, and at a distance of 50 feet from every other building (or screened by a wall 10 feet high and 12 inches thick). In all other cases a license is necessary, the terms of which are at the discretion of the Local Authority. *Inspection.*—The Corporation, or other local authority, must appoint inspectors annually. No oil may be kept or sold without having been inspected, and all oil failing to pass the standard test is considered as naphtha, the sale of which, under any assumed designation, is prohibited. Any inspector guilty of fraud, deceit, or culpable negligence in the discharge of his duties, is liable to fine or imprisonment, as well as to be mulcted in damages

for injury or loss sustained by any person through the explosion or ignition of any oil falsely certified by him (*Supplement to General Statutes*, vol. i, chapters clii and cccxlv). *Test*.—100° flash, Tagliabue open cup; or 110° fire, Tagliabue cup.

**CITY OF BOSTON.**—License is required, the conditions being left to the Corporation, except that a license may not be granted for storage at wharves or on inhabited premises, or for keeping any spirit elsewhere than in cellars, unless securely packed in metallic vessels. A license shall be held to be revoked if any of the conditions under which it is issued are not observed, and the Corporation may annul a license at any time.

**MICHIGAN.**—*Storage*.—No State law. *Test* (1893).—120° flash; Foster cup.

**MINNESOTA.**—*Storage*.—There are no State regulations. *Test*.—120° fire; Tagliabue cup. *Inspection*.—A supervisor of inspectors is appointed by the State, and he is required to confirm the nomination of inspectors made by the Local Authorities.

**TOWN OF DULUTH.**—The limit of storage is 20 barrels (5 barrels in the business districts), except in such cases and under such conditions as shall have been approved by the Board of fire engineers.

**CITY OF MINNEAPOLIS** and other cities.—The storage of petroleum is regulated by the fire marshal.

**MISSISSIPPI.**—No State law exists relating to petroleum products.

**MISSOURI.**—*Storage*.—No State regulations. *Inspection* (Law of 11th June 1879).—All oil "burning" below 150° F. must be branded—"Rejected for illuminating purposes"; above 150°, "Approved standard oil"; with inspector's name, date, place of examination, and the igniting point. Oils igniting at ordinary temperatures must be marked with specific gravity and "Highly inflammable." No oil or fluid igniting below 150° may be sold for illuminating except with a view to its use as vapour or gas. If oil in bulk is tested, the sample must be taken from the top of the storage tank, and the inspector or deputy must see the oil subsequently placed in the packages for sale, and brand the same. Selling uninspected or low-test oil, or fraudulently altering inspectors' brands, involves penalty. Inspectors are empowered to examine suspected oils, and must prosecute offenders. Delinquent inspectors can be dismissed. *Test*.—120° flash; Tagliabue cup.

**CITY OF JACKSON.**—The only conditions appear to be that buildings used for the storage of mineral oils must be fireproof and isolated.

**MONTANA.**—Fire wardens appointed under the State authority are empowered, among their other duties, to examine any building in cities or towns, and direct the removal of any inflammable material therein found, and test any oil they may find therein. *Test*.—110° flash; Foster cup.

**NEBRASKA.**—*Storage*.—No regulations. *Test*.—112° flash; Foster cup. *Application of Test* (Act of 27th February 1875).—Half a pint of oil is to be placed in a small vessel with a surface not exceeding 4 square inches, and gradually heated at a rate of not less than 2° per minute, as indicated by a thermometer immersed in the oil, to a temperature at which the oil will emit a "gas or vapour" that will ignite when the flame of a match or taper is brought in contact with it, the application of the light being carefully and frequently made so as to indicate the exact temperature at which ignition occurs. No untested or low-test oil may be sold for illuminating purposes under penalty of fine and imprisonment, and liability for damages in case of injury resulting from any infraction of this Act. Death resulting from infraction of Act is considered to be manslaughter on the part of the offender. Contracts made in contra-

vention of Act are invalid, and buyer may return the oil to vendor, and recover cost, freight, charges, and damages. No provision is made for inspection.

NEVADA.—No State law.

NEW HAMPSHIRE.—*Storage*.—The regulations are practically identical with those of Massachusetts (*q.v.*). *Test*.—100° flash, or 120° fire; Tagliabue cup. The sale of illuminating oil or compound, made from coal or petroleum, which will flash below 100°, or ignite below 120°, is prohibited. Sellers of oils below standard test are liable for any damage resulting from the ignition or explosion thereof.

NEW JERSEY.—Only such product of petroleum as will *not flash at a less temperature or flash-test than 100°*, may be sold for lighting or illuminating purposes, except where the same is to be used in street lamps or open-air receptacles, or in gas machines, in which case (as to petroleum or kerosene) there shall be plainly marked on the barrels, can, or vessel in which the same is sold, or offered or exposed for sale, or on a label securely fastened thereto, the words:—*Not for inside light*. *Test*.—100° flash; Elliott cup.

CITY OF HOBOKEN.—*Storage*.—For quantities in excess of 100 gallons a license is required, and this license defines the mode of construction of the place of storage and the amount to be kept. A safety zone of 200 feet from every dwelling-house and from manufacturing premises (except with the occupier's consent) is prescribed.

CITY OF NEWARK.—*Storage*.—There are no regulations, but the distillation or refining of petroleum within the city limits is prohibited. *Test*.—110° fire.

NEW MEXICO.—No oil of a fire test below 120°, Tagliabue cup, may be offered for sale, retail, for illuminating purposes.

NEW YORK (STATE).—*Storage (Revised Statutes, New York—Banke's sixth edition, vol. ii, p. 254, title vi, chap. xvii, part i)*.—No license is required. The limits of quantity are—

	Mineral Oil.	Mineral Spirit.
In any part of a dwelling, . . . . .	5 barrels.	3 barrels.
In buildings other than dwellings—		
Above cellar or { In barrels or re-	10 "	10 "
basement,        { tailing tanks,		
"                 { In hermetically	100 "	10 "
{ closed metal-		
{ lic packages,		
In cellars, etc., 2 feet below ground level, . . . . .	150 "	
In detached masonry or iron warehouses specially constructed, with floor 2 feet below ground level, 50 feet from other buildings, or separated by intervening wall 10 feet high and 16 inches thick, or ( <i>in case of refineries</i> ) in wrought-iron tanks outside any building, or buried in the ground, so that the top is at least 2 feet below the surface, and covered with a minimum thickness of 1 foot of earth, . . . . .	Unlimited.	

The Act is not to apply to any place where oil-springs may be discovered and worked. *Test*.—100° flash; 110° fire; Tagliabue cup.

CITY OF AUBURN.—No law relating to the storage of petroleum products.

CITY OF BROOKLYN (1881).—*Storage*.—A license from the Commissioner of

the Fire Department is required. In any building, occupied wholly or in part as a dwelling, only one barrel may be kept. The quantity, under other conditions, would (apparently) be prescribed by the license. *Test.*—110° fire; Tagliabue, or other approved instrument.

**CITY OF NEW YORK (1882).**—*Storage.*—The State law (*q.v.*) is specially applicable to the City of New York. An annual license is required, and a special permit for warehouses. The limits of quantity are—

	Oil.
Inside any part of a dwelling-house, . . . . .	1 barrel.
Above the first story of any other building, . . . . .	5 barrels.
Above the cellar or basement, . . . . .	{ 10 or 50   " in the daytime.

For larger quantities, the regulations are the same as those in the State of New York, but it is not clear whether any spirit may be kept. In one place, the storage of spirit is prohibited, except in detached warehouses, but it appears to be sanctioned in another paragraph, under the same conditions as refined oils. Elsewhere, however, the keeping of spirit for illuminating or heating purposes is forbidden. *Test.*—100° flash; Elliott cup.

*Regulations governing vessels lying in Petroleum Docks in the Counties of New York, King's, and Queen's (Law of 19th May 1879, chap. 324).*—Captain must report arrival of vessel. No fires or lights are allowed on board without written permission of the wharfinger, who will supply cooking conveniences. No fires, smoking, or lights of any kind allowed on boats or vessels—except steam-tugs and fire-engines in the discharge of their duties—lying within 150 feet of any place where petroleum, or its products, is kept for export, or in quantities exceeding 10,000 gallons, unless by permission, in writing, of the owner, lessee, or superintendent of such store, specifically stating the kind of light or fire, and the purpose and place for which it is required.

*Port of New York Harbour Master's Regulations, 1st July 1880.*—These rules relate to the position of vessels lying at wharves, and, generally, to the control of vessels while in the port, without particular reference to petroleum ships. The heating of pitch, tar, or other combustibles on board vessels at wharves, etc., in New York or Brooklyn, is prohibited.

**CITY OF POUGHKEEPSIE (1874).**—*Storage.*—No license is needed; 10 barrels of oil may be kept in any store or building within 300 feet of any dwelling-house, and an unlimited quantity beyond this distance.

**CITY OF SYRACUSE.**—*Storage.*—The regulations are the same as for the State of New York (*q.v.*). *Test.*—110° fire; Tagliabue cup.

**NORTH CAROLINA.**—This state has in effect an inspection law which prohibits the sale of refined oil that has a flash test of less than 100° when tested in an Elliott closed cup. *Test.*—100° flash; Elliott cup.

**NORTH DAKOTA.**—*Test.*—100° flash; 125° fire; Elliott cup.

**OHIO.**—*Storage.*—No State law, but laws and regulations similar to those in force in Philadelphia (*q.v.*) prevail in all the chief cities. *Inspection (Law of 15th May 1878).*—Manufacturers, retailers, and others offering low-test or untested oils for sale for lighting purposes, except to municipal authorities for lighting street lamps, are liable to fines, and are further liable for any injuries caused by the ignition of such oils. A buyer, finding any oil to be below standard test, may return the same to the vendor, and recover cost, carriage, and damages. Inspectors or deputies must brand all vessels containing standard-test oil—"approved"; and low-test oil—"rejected for illuminating purposes"; with date of inspection. Inspectors are sworn, must furnish bond

for surety, must keep a record of all tests, open for inspection, and make an annual return to the Governor. Deputies must make a monthly return to the chief inspector. No inspector or deputy may trade directly or indirectly in any oil or product which he is appointed to inspect. Breach of this rule, or other dereliction of duty, involves fines and dismissal. Disputed tests must be submitted to the State chemist of the Agricultural College at Columbus, and his decision shall be final. Fraudulently altering inspectors' brands, or refilling branded vessels with untested oil, is a misdemeanour. No empty branded casks or vessels may be sold without the marks being first obliterated. The adulteration of standard with low-test oils is prohibited, if they are thereby rendered dangerous. Gas or vapour from low-test oils may be used for illumination, provided the liquid is contained in underground reservoirs outside the building lighted by such gas. *Test.*—120° flash; Foster cup.

CITY OF CINCINNATI.—*Storage.*—Within certain "fire limits," the quantity allowed to be kept in any one building is restricted to 10 barrels, unless specially erected stores at least 60 feet from any other building are employed, in which case there does not appear to be any limit as to quantity. The smaller dealers are nominally restricted to 5 barrels.

OKLAHOMA TERRITORY.—*Test.*—115° flash; Tagliabue open cup.

OREGON.—*Test.*—120° fire; Tagliabue cup.

CITY OF PORTLAND.—*Storage.*—A license is requisite for the storage of over 1000 gallons of petroleum "that will emit an inflammable vapour" (no mention being made of temperature or testing instrument). This regulation does not seem to apply outside a certain specified area. The construction of stores for larger quantities appears to be regulated by the license.

PENNSYLVANIA.—*Pennsylvania State Laws for Petroleum (P. L. 189, 15th May 1874):*—

1. No refined petroleum, kerosene, naphtha, benzol, gasoline, or any fluid, be they designated by whatsoever name, the fire test of which shall be less than 110 degrees Fahrenheit, shall be sold or offered for sale as an illuminator for consumption within the limits of the Commonwealth of Pennsylvania.

2. Said fire test shall be determined by an inspector appointed under the provisions of this Act, who shall use Tagliabue's or such other well-defined instrument as may be used by the inspectors of export oil, according to the following formula:—Heat with alcohol, small flame; when thermometer indicates ninety degrees, remove lamp; at ninety-five try for a flash, with small bead of fire on end of string, held within a quarter of an inch of surface of oil; replace lamp, and work oil up gradually from this point until the burning-point is reached, removing lamp every four degrees, and allowing oil to run up three degrees before replacing lamp, flashing oil each time, just before lamp is replaced, until result is attained.

3. The said inspector shall be appointed by the Courts of Common Pleas, one in each county in the commonwealth, wherein said burning oil or fluids, as before mentioned, are manufactured: *Provided* that, in any county where there shall be more than one Court of Common Pleas, the said appointments shall be made by Court No. 1 in said counties, and in any county wherein is situated a city of more than three hundred thousand inhabitants, in such case, in lieu of Court No. 1, the appointment of inspector shall be made by the mayor of said city.

4. The said inspectors shall hold their office for the term of three years, unless sooner removed by the appointing power for incompetency, or found guilty under the provisions of this Act; vacancies in said office to be filled by the authority in which the appointing power is vested by this section. The said inspectors shall be authorised to appoint such clerks or deputies as they may find requisite for the carrying out of the duties specified under this Act; the said clerks and deputies shall be paid out of the fees of the office by the inspector of the county wherein the service is performed; all clerks and deputies are held answerable by this Act, and subject to the same penalties for violating any of its provisions as are provided in this Act for the punishment of the appointed inspectors. Each inspector, deputy or clerk, after receiving his appointment, and prior to entering upon the duties of the office for which he is appointed, shall file in the office of the prothonotary of the Court of Common Pleas, an oath or affirmation that he will well and truly perform the duties of his office, and carry out the provisions of this Act, and said inspectors shall also file a bond, with one or more approved

securities, in style similar to that of the sheriff of the county, in the penal sum of ten thousand dollars, for the faithful performance of the duties of said inspector's office, as provided in this Act. The said inspector is hereby empowered to receive and collect from the manufacturer or owner, the sum of twenty cents per package for each package inspected in any lot under ten; ten cents per package for each package inspected in any lot not more than fifty; seven cents per package for each package inspected in any lot or all lots over fifty; and one dollar for each car of bulk refined oil; and in case any person shall call upon said inspector to inspect one package of refined oil, he shall charge said person for each inspection fifty cents. The said inspector shall provide, at his own cost, stencils for the purpose of branding packages, to read thus—"State of Pennsylvania, fire test one hundred and ten degrees," with name of inspector: *Provided*, when oil so inspected shall stand higher test, the inspector shall designate such actual test by his brand.

5. The said inspector, or his clerks or deputies, shall, and are hereby empowered to, enter any place or building where oil or fluids, as before designated in this Act, are manufactured, kept in store for sale or consumption, in this commonwealth, and in such counties where oil is sold and not manufactured, for which no inspector has been appointed, or in any other place within the limits of this State, wherein he has reason for believing that oil is being kept or sold contrary to the provisions of this Act, or for the purpose of carrying out the true intent and meaning of this Act, any inspector shall have the privilege to reinspect, and is hereby empowered to inspect any oil, as hereinbefore designated in section first, which he may by any reason believe to be under fire test, and if so found by him to be under fire test, and falsely branded, he shall prosecute, or cause to be prosecuted, the offender, as herein authorised in section four of this Act; no charge shall be made for reinspection.

6. Any person violating any of the provisions of this Act shall, upon conviction thereof, be deemed guilty of a misdemeanour, and shall be subject to a fine of not less than two hundred and fifty (\$250) dollars, nor more than five hundred (\$500) dollars, or imprisonment not less than one year, or both, at the discretion of the Court, one-half of said fine to go to the prosecutor, and one-half to the school fund in the district where such misdemeanour may have been committed. Also, if any person shall sustain damage to his property or injury to his person, by reason of a violation of any of the provisions of this Act by another person, the person guilty of said violation shall be liable to the person injured, for all damages sustained thereby.

7. All the oils or fluids, subject to inspection under this Act, that may be found in the hands of those who sell in less quantities than one barrel, with a fraudulent brand or mark of inspection, or found to have been adulterated, or not coming up to the fire test, as the mark of inspection would indicate, shall be subject to seizure by the said inspector, and the same shall, after ten days' public notice, be sold wholly for redistillation, the proceeds of such sale after deducting the necessary expenses of sale and seizure, shall one-half be given to the public school fund wherever the seizure was made, and one-half to the informer.

8. Any inspector or deputy appointed under this Act, who shall violate any of its provisions by neglecting to inspect upon request, or shall falsely brand any oil or fluid, shall be deemed guilty of a misdemeanour, and, upon conviction thereof, shall be fined not less than two hundred and fifty (\$250) dollars, nor more than one thousand (\$1000) dollars, and be subject to imprisonment for not less than three months or more than one year, or both, subject to the discretion of the Court, one-half of the fine to go to the informer, and one-half to the school fund of the district wherein the offence was committed.

9. The packages containing oil manufactured for export shall be branded with a stencil by the manufacturer, with the words "For export"; all benzine, naphtha, or any hydrocarbons created in the manufacture of refined oil from crude petroleum, or otherwise manufactured, shall be inspected and branded "benzine," and shall not be kept for sale or used in any way for giving light to be burned in lamps, and this Act shall not be construed to prohibit their use in making gas to be conveyed through pipes to burners, similar to gas in city gas works, to be used for the same purpose, and further, the penalties for violating this section shall be the same as applied to the use of refined oil below legal test.

10. Nothing contained in this Act shall be construed or held to apply in any manner to any kind of oil or fluid manufactured for export from this State, or in transit from one State to another through the limits of this commonwealth.

11. Any person or persons who shall sell, or cause to be sold, any barrel or package, or who shall refill the same without first removing the brand of the inspector, shall be liable to a fine of three hundred dollars for every barrel or package sold or delivered or refilled; said fines shall be recoverable as other fines of like character are recoverable by law, and one-half shall go to the informer, and one-half to the school fund of the district in which the offence was committed.

CITY OF PHILADELPHIA.—*Storage*.—An annual license from the Corporation is necessary. Within certain limits in the city, 25 barrels of oil, or 1 barrel of

mineral spirit, may be kept in cellars, or on premises properly excavated or embanked to prevent outflow. Beyond the aforesaid limits, oil may be stored up to any amount in buildings, tanks, or excavations approved by the fire marshal, and situated at least 100 feet from any dwelling. This does not apply to any dwelling in respect of which the consent of the occupier has been obtained. Oil in bond or for export, beyond the confines of Pennsylvania, is not subject to the Act (1865). *Test.*—110° fire; Tagliabue cup.

**RHODE ISLAND.**—*Storage.*—No license is necessary. Limits of quantity :—

	Oil.
In any store or warehouse, . . . . .	3 barrels.
In cellars 4 feet below ground level, and not below a dwelling, . . . . .	10 „
In warehouses of masonry or iron, specially constructed, . . . . .	100 „
Ditto, 50 feet from buildings and wharves (or if less than 50 feet, separated by masonry wall 10 feet high and 16 inches thick), and constructed to prevent outflow, . . . . .	Unlimited.

Apparently no mineral spirit may be kept, at any rate for illuminating purposes. *Test.*—110° flash; Tagliabue open cup. *Inspection.*—The sale of oil flashing below 110°, and the transfer from the original packages of any oil or spirit brought into the State, until it has been inspected, are prohibited under penalty. Inspectors must brand every cask with the flashing-point of the oil in a legible manner. The obliteration or alteration of inspectors' brand marks, or putting untested oil into packages already bearing such brands, is punishable by fine or imprisonment (*General Statutes of Rhode Island and Providence Plantations*, title xvi, chap. 112).

**SOUTH CAROLINA.**—This State has in effect an inspection law which prohibits the sale of refined oil that has a flash test of less than 100° when tested in an Elliott closed cup.

**CITY OF CHARLESTON.**—*Storage.*—No license is required. The maximum amount of any petroleum products or other inflammable oils, which may be kept in any cellar, store, or building, or any one block of premises in the principal portion of the city (*i.e.* south of Line Street) is 50 gallons, and this must be kept in vessels of tin or other metal. Oils are only subject to these regulations after a lapse of twenty-four hours from the time of their arrival in the city.

**SOUTH DAKOTA.**—*Test.*—150° flash; Tagliabue cup.

**CITY OF YANKTON.**—*Storage.*—Permission must be obtained from the City Council for the storage of 5 barrels (the limit of quantity) within the fire limits of the city.

**TENNESSEE.**—*Storage.*—No State law. *Inspection* (State Law, 10th March 1877).—An inspector of illuminating oils is to be appointed by the Governor, for each city and county having a population of 1000 and over, to inspect and test all illuminating oils made or offered for sale in the State, and to brand all vessels either as—“Approved standard oil” (stating the flashing-point), if they pass the test; or as—“Rejected,” if they fail to do so; and in the latter case, if they are inflammable at ordinary temperatures, with the specific gravity as well. An inspector or his assistant may go to any county not provided with an inspector, if he learns that low-test oil is being sold for illuminating purposes without being branded, and may test the same. Furthermore, he may inspect oils in transit from other States to counties having no inspector, and if the same fail to pass the test, may send them back to the shipper; but if the said oils are plainly marked by the manufacturer or shipper as not intended for illuminating purposes, they may be allowed to go forward

to their destination. The inspector's fees on oils in transit are collected from the carrier or forwarding agent, who has a lien on the goods until repaid by the shipper. Refusal on the part of a carrier to pay the fees, or obstruction, by anyone, of the inspector in the discharge of his duties, is punishable by fines, as is also the selling of low-test or untested oil for lighting purposes, or fraudulent alteration of brands. *Test.*—120° flash; Tagliabue open cup. The "standard" instrument must be used. The water bath must contain sufficient water to rise two-thirds up the side of the oil cup. The latter must be filled up to  $\frac{1}{8}$  of an inch from the top, with the oil to be tested, and be provided with a thermometer, the bulb of which is just covered by the oil. The oil is first tested, before applying heat, by bringing a lighted match in contact with its surface. If no flash occurs, it is then slowly heated by means of an alcohol lamp at the rate of 1° to 2° per minute, a lighted match being drawn across the surface at a distance of  $\frac{3}{8}$  of an inch, at each degree rise, until a flash occurs.

**CITY OF MEMPHIS.**—*Storage.*—In certain parts of the city, not more than 5 barrels (and even then only in tin cases) may be stored on the same premises. In the remaining districts there does not seem to be any limit as to quantity, provided that storage takes place in fireproof buildings approved by the chief of the fire brigade.

**TEXAS.**—No State law exists relating to petroleum products.

**CITY OF GALVESTON.**—*Storage.*—Not more than 40 gallons may be stored in a dwelling, or above the first floor of any building. Beyond this quantity of "camphene or dangerous inflammable fluid, such as kerosene, naphtha, or any inflammable oil of any kind or nature whatever," a license from the mayor is required, but this license may only be granted on certificate from the chief engineer of the fire brigade that the building is suitably arranged for the prevention of outflow, and that the adjoining premises would not be endangered in case of fire. It is forbidden to grant a license for storage in any dwelling, or for storage above the first floor in any building, or for storage in "any street, alley, or wharf." The police, and the chief engineer of the fire brigade, or person authorised by the mayor, may enter and inspect stores, and take samples.

**UTAH.**—*Test.*—110° fire; Tagliabue open cup.

**VERMONT.**—*Storage.*—The regulations in the State are practically identical with those of Massachusetts (*q.v.*). *Test.*—110° fire; Tagliabue cup.

**VIRGINIA.**—No State regulations relating to petroleum products.

**CITY OF RICHMOND.**—*Storage.*—No law. *Test.*—110° fire; Tagliabue cup.

**WASHINGTON.**—*Test.*—120° fire; Tagliabue cup.

**WEST VIRGINIA.**—No State regulations applying to petroleum.

**WISCONSIN.**—*Storage.*—No State law. *Inspection.*—The appointment of a State supervisor of inspectors is compulsory. The appointment of inspectors to test oils is vested in the supervisor—*i.e.* this official confirms the nominations made by local authorities. *Test.*—125° fire and 105° flash; Tagliabue cup.

**CITY OF MADISON.**—*Storage.*—The limit of quantity is 6 barrels, but no license is required.

**CITY OF MILWAUKEE.**—*Storage.*—Mineral spirit may be kept only in approved fireproof buildings, exclusively appropriated to the storage of such articles in such quantities as may be assigned in the license. Refined petroleum of over 110° test may be stored to the extent of 6 barrels by day, or 1 barrel by night, without license. Above these limits, the place of storage must be a fireproof building, sufficiently removed and detached from other buildings,



approved by the chief engineer of the fire department, and duly licensed.  
*Test.*—110° flash.

WYOMING.—*Test.*—110° flash; Foster cup. Fire wardens, appointed under the State authority, are empowered, among their other duties, to examine any building in cities or towns, and direct the removal of any inflammable material therein found, and test any oils they may find therein.

VICTORIA—See AUSTRALIAN COMMONWEALTH.

WEST AUSTRALIA—See AUSTRALIAN COMMONWEALTH.

### ZANZIBAR.

By a decree of the Sultan, Sayyid Ali Byn Said, dated 27th April 1892, it was ordained that all petroleum, kerosene, and other "explosive" oils for lighting purposes (without reference to flashing-point) should be stored, immediately on arrival, in a specially appointed warehouse. The limit of quantity to be stored in a house, or on other premises, is 10 cases, but responsible merchants are allowed to keep up to 50 cases in their own godowns.

TABLE CLXV.—STANDARD FLASH-POINTS AND METHODS OF TESTING.

Country.	Flash-point.	Method of Testing.
Antigua, . . . . .	83° F.	Abel.
Australian Commonwealth, . . . . .	73° F.	Abel-Pensky.
New South Wales, . . . . .	73° F.	" "
South Australia, . . . . .	73° F.	" "
Tasmania, . . . . .	73° F.	" "
Austria, . . . . .	70° F.	Abel.
Bahamas, . . . . .	94° F.	As prescribed by "Rule."
Barbados, . . . . .	83° F.	Abel.
Belgium, . . . . .	..	..
Antwerp, . . . . .	..	..
Bermuda, . . . . .	73° F.	Abel.
Britain, . . . . .	73° F.	Abel.
British Baluchistan and British Burma, . . . . .	..	See India.
British Guiana, . . . . .	85° F.	Abel, or Abel-Pensky.
British Honduras, . . . . .	100° F.	Abel.
Canada, . . . . .	85° F.	"
Cape Colony, . . . . .	..	No regulations.
Ceylon, . . . . .	76° F.	Abel-Pensky.
China, . . . . .	..	No regulations.
Cyprus, . . . . .	No standard.	..
Denmark, . . . . .	73° F.	Abel-Pensky.
Copenhagen, . . . . .	70° F.	Abel.
Dominica, . . . . .	100° F.	Open test.
Falkland Islands, . . . . .	..	No regulations.
Fiji, . . . . .	78° F.	Abel.
France, . . . . .	95° F.	Granier.
Gambia, . . . . .	95° F.	Abel.
Germany, . . . . .	21° C.	Abel-Pensky.
Gibraltar, . . . . .	73° F.	Abel.
Gold Coast, . . . . .	No standard.	..
Greece, . . . . .	..	..
Grenada, . . . . .	80° F.	Abel.
Guernsey, . . . . .	73° F.	Abel-Pensky.
Holland, . . . . .	21° C.	Abel.

TABLE CLXV.—STANDARD FLASH-POINTS, ETC.—*continued.*

Country.	Flash-point.	Method of Testing.
Hong Kong, . . . . .	150° F.*	None specified.
India, . . . . .	{ 76° F. 200° F.* }	Abel-Pensky.
Isle of Man, . . . . .	73° F.	Abel.
Italy, . . . . .	21° C.	None specified.
Genoa, . . . . .	21° C.	Abel.
Rome, . . . . .	30° C.	"
Naples, . . . . .	21° C.	None specified.
Jamaica, . . . . .	95° F.	Abel.
Japan, . . . . .	86° F.	Close test.
Osaka, . . . . .	21° C.	Abel.
Jersey, . . . . .	73° F.	Close test.
Labuan, . . . . .	No standard.	"
Malay States, . . . . .	73° F.	Abel-Pensky.
Malta, . . . . .	76° F.	Abel.
Mauritius, . . . . .	73° F.	"
Montserrat, . . . . .	83° F.	"
Natal, . . . . .	No standard.	"
Newfoundland, . . . . .	85° F.	Abel-Pensky.
New Brunswick, . . . . .	No standard.	"
New Zealand, . . . . .	110° F.	Open test.
Nigeria (Southern), . . . . .	No standard.	"
North Borneo, . . . . .	"	"
Norway, . . . . .	22° C.	Abel.
Portugal, . . . . .	No standard.	"
Rumania, . . . . .	23° C.	Abel-Pensky.
Russia, . . . . .	28° C.	" "
St. Christopher and Nevis, . . . . .	83° F.	Abel.
St. Lucia, . . . . .	95° F.	"
St. Vincent, . . . . .	83° F.	Abel-Pensky.
Seychelles, . . . . .	90° F.	Apparatus deposited with Customs.
Sierra Leone, . . . . .	95° F.	Abel.
Spain, . . . . .	No standard.	"
Straits Settlements, . . . . .	{ 73° F. 150° F.* }	Abel-Pensky.
Sweden, . . . . .	{ 22° C. 40° C.* }	Abel.
Switzerland, . . . . .	{ 23° C. 38° C.* }	Abel.
Trinidad and Tobago, . . . . .	95° F.	"
Turkey, . . . . .	No standard.	"
United States—		
Alabama, . . . . .	120° F.	Fire; Tagliabue cup.
Arizona, . . . . .	"	No regulations.
Arkansas, . . . . .	150° F.	Fire; Tagliabue cup.
California, . . . . .	110° F.	Flash; open test.
City of Los Angeles, . . . . .	110° F.	Tagliabue open cup.
City of Sacramento, . . . . .	110° F.	" " "
City of San Francisco, . . . . .	100° F.	" " "
Colorado, . . . . .	90° F.	Flash; Foster cup.
City of Denver, . . . . .	110° F.	Tagliabue open cup.
Columbia, . . . . .	"	No regulations.
Connecticut, . . . . .	110° F.	Flash; Tagliabue open cup.
City of Meriden, . . . . .	125° F.	Fire.
City of New Haven, . . . . .	110° F.	Fire; Tagliabue cup.
Delaware, . . . . .	115° F.	" " "
City of Wilmington, . . . . .	110° F.	Fire.

\* All above exempted from regulation.

TABLE CLXV.—STANDARD FLASH-POINTS, ETC.—*continued.*

Country.	Flash-point.	Method of Testing.
United States ( <i>cont.</i> )—		
Florida, . . . . .	..	No State law.
Georgia, . . . . .	140° F.	Elliott cup.
Idaho, . . . . .	120° F.	Fire ; Tagliabue cup.
Illinois, . . . . .	150° F.	Fire ; Tagliabue cup.
Indiana, . . . . .	120° F.	Tagliabue open cup.
Indian Territory, . . . . .	..	No State law.
Iowa, . . . . .	100° F.	Elliott cup.
Kansas, . . . . .	110° F.	Foster cup.
Kentucky, . . . . .	130° F.	Fire ; Tagliabue cup.
Louisiana, . . . . .	125° F.	Tagliabue open cup.
City of New Orleans, . . . . .	110° F.	Fire ; Tagliabue cup.
Maine, . . . . .	120° F.	" " "
Maryland, . . . . .	110° F.	" " "
City of Baltimore, . . . . .	120° F.	..
Massachusetts, . . . . .	{ 100° F. or	Tagliabue open cup.
	110° F.	Fire ; Tagliabue cup.
Michigan, . . . . .	120° F.	Foster cup.
Minnesota, . . . . .	120° F.	Fire ; Tagliabue cup.
Mississippi, . . . . .	..	No State law.
Missouri, . . . . .	120° F.	Flash ; Tagliabue cup.
Montana, . . . . .	110° F.	Probably Tagliabue cup.
Nebraska, . . . . .	112° F.	Foster cup.
Nevada, . . . . .	..	No State law.
New Hampshire, . . . . .	{ 100° F. or	Tagliabue open cup.
	120° F.	Fire ; Tagliabue cup.
New Jersey, . . . . .	100° F.	Elliott cup.
City of Newark, . . . . .	110° F.	Fire.
New Mexico, . . . . .	120° F.	Fire ; Tagliabue cup.
New York (State), . . . . .	100° F.	Tagliabue cup.
City of Brooklyn, . . . . .	110° F.	Fire ; Tagliabue cup.
City of New York, . . . . .	110° F.	Elliott cup.
City of Syracuse, . . . . .	110° F.	Fire ; Tagliabue cup.
North Carolina, . . . . .	100° F.	Elliott cup.
North Dakota, . . . . .	100° F.	" "
Ohio, . . . . .	120° F.	" "
Oklahoma Territory, . . . . .	115° F.	Flash ; Tagliabue open cup.
Oregon, . . . . .	120° F.	Fire ; Tagliabue cup.
Pennsylvania, . . . . .	110° F.	" " "
City of Philadelphia, . . . . .	110° F.	" " "
Rhode Island, . . . . .	110° F.	Tagliabue open cup.
South Carolina, . . . . .	100° F.	Flash ; Elliott cup.
South Dakota, . . . . .	150° F.	Flash ; Tagliabue cup.
Tennessee, . . . . .	120° F.	Tagliabue open cup.
Texas, . . . . .	..	No State law.
Utah, . . . . .	110° F.	Fire ; Tagliabue open cup.
Vermont, . . . . .	110° F.	Fire ; Tagliabue cup.
Virginia, . . . . .	..	No State law.
City of Richmond, . . . . .	110° F.	Fire ; Tagliabue cup.
Washington, . . . . .	120° F.	" " "
West Virginia, . . . . .	..	No State law. "
Wisconsin, . . . . .	{ 105° F. and	Tagliabue cup.
	125° F. (fire)	..
City of Milwaukee, . . . . .	110° F.	..
Wyoming, . . . . .	110° F.	Flash ; Foster cup.
Zanzibar, . . . . .	No standard.	..

**Concluding Remarks.**—From the particulars which have been given in this table and in a previous section (Sec. IX, vol. iii), it will be evident that there

is a regrettable absence of uniformity in the methods of testing adopted, not only in different countries, but also in the various States of the American Union. The existence of considerable diversity in regard to the test-standard to be adopted with any one system of testing is also exhibited in the laws which have been framed in the United States. The latter condition, no doubt, arises from the fact that, until within comparatively recent years, no systematic attempts were made to determine the relation between the flashing-point of an oil and its safe or dangerous character in ordinary use. Moreover, when petroleum was first introduced, it was often carelessly or improperly handled, and the accidents which occurred led to an exaggerated estimate being formed of the risk involved in the use of the oil as an illuminant, with the result that legislative restrictions of a needlessly stringent description were placed upon the trade. It may be added that in certain of the States, the oil in general use, prior to the adoption of any restriction as to "test," was of high flashing-point, and in these cases the standard, or limit of test, was simply based upon the character of the oil commonly employed in the locality.

## APPENDIX A.

---

### STATISTICS.

Full statistical data relating to the United States, which occupies the predominant position with regard to the production of crude oil, will be found in the following pages. Owing to the war, it has been found exceedingly difficult to obtain reliable figures for Galicia, Germany, Hungary, Rumania, and Russia. The figures given have been compiled from the publications of the United States Geological Survey, and from information obtained from various Government Departments and other reliable sources. It has been impossible to obtain satisfactory data with regard to the production of ozokerite and asphalt.

PRODUCTION OF CRUDE PETROLEUM IN THE UNITED STATES FROM 1875 TO 1918.  
(In Barrels of 42 American Gallons.)

Year.	Pennsylvania and New York.	Ohio.	West Virginia.	Colorado.	California.	Indiana.	Kentucky and Tennessee.	Illinois.	Kansas.	Texas.	Missouri.	Oklahoma.	Wyoming.	Louisiana.	Total, United States.
1875	65,283,438														665,283,438
1876	8,787,514	82,000,000	63,000,000		6175,000										612,162,514
1877	8,969,960	31,763	120,000		12,000										9,132,669
1878	15,135,475	29,888	172,000		13,000										13,350,363
1879	15,183,462	28,179	180,000		15,227										15,396,868
1880	29,682,176	29,119	180,000		19,858										19,914,146
1881	26,927,631	33,840	179,000		90,852										26,386,123
1882	27,376,000	33,867	151,000		99,862										27,661,238
1883	30,053,000	39,761	128,000		128,636										30,510,830
1884	23,128,389	47,632	126,000		142,857										23,449,633
1885	20,776,041	661,880	31,000		325,000										24,218,438
1886	25,798,000	1,732,790	102,000		678,572										28,064,841
1887	25,356,193	5,022,632	146,000		690,333										28,983,483
1888	16,488,668	10,010,366	119,448		33,375										35,163,513
1889	21,487,435	12,417,466	942,178		305,220										45,823,572
1890	23,009,236	17,740,301	2,406,218		307,360										54,992,633
1891	28,422,377	16,124,666	492,578		325,000										50,409,657
1892	20,314,513	16,249,769	8,445,412		385,049										48,431,066
1893	19,019,990	16,792,164	8,577,624		470,179										48,844,516
1894	19,262,066	21,560,513	13,090,048		705,969										52,892,276
1895	20,584,421	23,941,169	10,019,770		1,208,482										60,560,361
1896	18,948,464	18,738,708	13,615,011		1,252,777										46,584,233
1897	14,559,127	22,362,730	16,985,675		1,930,411										43,070,850
1898	13,183,996	21,014,231	13,513,345		2,257,207										63,620,329
1899	12,518,134	20,480,286	12,899,305		2,642,095										69,389,194
1900	11,554,717	16,346,660	11,578,110		4,324,848										100,461,337
1901	12,239,226	18,776,631	12,644,636		5,786,330										117,063,421
1902	11,554,410	14,787,763	10,120,935		13,984,268										134,717,986
1903	11,211,606	12,207,448	9,095,296		24,382,472										188,766,916
1904	10,584,453	10,868,797	9,232,176		33,427,473										166,095,335
1905	10,434,300	10,632,793	10,745,092		33,098,598										178,527,355
1906	9,848,500	9,916,370	11,465,464		39,748,375										200,457,248
1907	9,200,673	8,817,112	12,128,962		44,854,737										220,435,044
1908	8,865,493	8,781,488	11,667,293		37,748,327										242,498,898
1909	8,105,909	8,536,326	9,680,033		39,583,629										265,762,635
1910	8,726,483	7,825,326	9,264,798		44,854,737										281,104,104
1911	8,466,481	7,744,511	8,731,184		44,854,737										300,767,158
1912	8,612,885	7,750,540	8,379,285		44,854,737										335,315,601
1913	8,216,655	7,283,005	7,866,628		44,854,737										355,927,716
1914															
1915															
1916															
1917															
1918															
Total	785,202,717	463,367,386	294,474,710	11,319,370	1,110,226,576	106,105,584	18,213,188	298,225,380	148,450,328	327,550,005	119,225,851	320,457,911	150,769,911	4,608,571,719	

NOTE TO PRECEDING TABLE.

In the United States, the barrel of crude oil is reckoned as 42 American gallons, and the barrel of refined oil, or other product, as 50 American gallons (100 American gallons=83.3 Imperial gallons). *a* In addition to this amount, it is estimated that for want of a market some 10,000,000 barrels ran to waste, in and prior to 1862, from the Pennsylvanian fields; also a large amount from West Virginia and Tennessee. *b* Including all production prior to 1876 in Ohio, West Virginia, and California. *c* This includes all the petroleum produced in Kentucky and Tennessee prior to 1883. *d* In addition to this quantity, 4325 barrels of crude oil were produced in Kentucky and Tennessee in 1896, 4377 barrels in 1897, 19,152 barrels in 1898, and 13,578 barrels in 1899, for which, as none was sold or used, no value could be given. *e* Includes the production of Michigan. *f* Includes the production of Michigan and small production in Oklahoma Territory. *g* Included with Kansas. *h* In addition to this quantity, about 3,670,000 barrels were produced and unsold in 1904. *i* Includes production of Oklahoma. *k* Estimated. *l* Includes production of Utah. *m* No production in Tennessee recorded. *n* Includes small production of Alaska. *o* No production in Missouri; Michigan included in Ohio. *p* Includes production of Alaska, Michigan, and New Mexico. *q* Includes production of Alaska and Michigan. *r* Includes 44,917 barrels from Montana. *s* Includes 99,399 barrels from Montana. *t* Production of Alaska and Michigan. *u* Includes 69,323 barrels from Montana.

In the *Oil, Paint, and Drug Reporter* (New York) of 22nd July 1895, Mr. A. C. Ferris points out that, whereas the official statistics of the production of petroleum in the United States began with the year 1859, there was a considerable amount of business transacted in petroleum for use as an illuminant during the two previous years.

The preliminary figures for 1919 and 1920 are given by the United States Geological Survey as follows :—

Field.	Quantity.	
	Barrels of 42 U.S.A. Gallons.	
	1919.	1920.
Appalachian, . . . . .	29,232,000	30,511,000
Lima-Indiana, . . . . .	3,444,000	3,059,000
Illinois, . . . . .	12,436,000	10,772,000
Mid-Continent—		
Oklahoma-Kansas, . . . . .	115,897,000	144,226,000
Central and North Texas, . . . . .	67,419,000	70,952,000
North Louisiana, . . . . .	13,575,000	33,896,000
Gulf Coast, . . . . .	20,568,000	26,801,000
Rocky Mountain, . . . . .	13,584,000	17,517,000
California, . . . . .	101,564,000	105,668,000
Total, . . . . .	377,719,000	443,402,000

POSITION OF PETROLEUM-PRODUCING STATES, WITH AMOUNT PRODUCED AND  
PERCENTAGE OF EACH IN 1917 AND 1918.

1917.

State.	Amount in U.S. Barrels.	Percentage.
Oklahoma, . . . . .	107,507,471	32-06
California, . . . . .	93,877,549	28-00
Kansas, . . . . .	36,536,125	10-90
Texas, . . . . .	32,413,287	9-67
Illinois, . . . . .	15,776,860	4-70
Louisiana, . . . . .	11,392,201	3-40
Wyoming, . . . . .	8,978,680	2-68
West Virginia, . . . . .	8,379,285	2-50
Ohio, . . . . .	7,750,540	2-31
Pennsylvania, . . . . .	7,733,200	2-30
Kentucky, . . . . .	3,088,160	.92
New York, . . . . .	879,685	.26
Indiana, . . . . .	759,432	.23
Colorado, . . . . .	121,231	.04
Montana, . . . . .	99,399	.02
Tennessee, . . . . .	12,196	} .01
Alaska, . . . . .	10,300	
Michigan, . . . . .		
Total, . . . . .	335,315,601	100-00

1918.

Oklahoma, . . . . .	103,347,070	29-03
California, . . . . .	97,531,997	27-40
Kansas, . . . . .	45,451,017	12-77
Texas, . . . . .	38,750,031	10-89
Louisiana, . . . . .	16,042,600	4-51
Illinois, . . . . .	13,365,974	3-76
Wyoming, . . . . .	12,596,287	3-54
West Virginia, . . . . .	7,866,628	2-21
Pennsylvania, . . . . .	7,407,812	2-08
Ohio, . . . . .	7,285,005	2-05
Kentucky, . . . . .	4,367,968	1-23
Indiana, . . . . .	877,558	.25
New York, . . . . .	808,843	.22
Colorado, . . . . .	143,286	.04
Montana, . . . . .	69,323	} .02
Tennessee, . . . . .	8,374	
Alaska, . . . . .	7,943	
Michigan, . . . . .		
Total, . . . . .	355,927,716	100-00



QUANTITY OF CRUDE PETROLEUM PRODUCED IN, AND THE QUANTITIES AND VALUES OF PETROLEUM PRODUCTS EXPORTED FROM, THE UNITED STATES DURING EACH OF THE CALENDAR YEARS FROM 1879 TO 1918 INCLUSIVE.

PRODUCTION.

Year ending Dec. 31.	Barrels (of 42 gallons).	Gallons.		Crude (including all natural oil without regard to specific gravity.)		Naphthalene, Benzene, Gasoline, etc.		Illuminating.		Refined or Manufactured.		Exports.	Residuum (tar, pitch, and all other, from which the light oils have been distilled).	Total.
		Gallons.	Dollars.	Gallons.	Dollars.	Gallons.	Dollars.	Gallons.	Dollars.	Gallons.	Dollars.			
1879	19,014,146	836,894,132	28,601,650	2,089,458	19,524,582	1,367,936	365,597,447	32,811,756	3,168,561	713,298	273,050	421,719,782	37,235,467	
1880	27,286,123	1,104,017,166	36,748,116	2,779,420	16,115,131	1,384,529	286,131,567	29,442,901	9,068	1,411,825	4,327,522	373,050	37,235,467	41,505,645
1881	37,670,233	1,511,771,996	40,430,108	4,039,287	20,655,116	1,981,197	444,666,615	42,192,683	6,053,862	1,165,605	3,776,030	198,983	346,779,443	48,566,103
1882	39,406,389	1,636,440,860	46,011,154	4,378,037	16,969,839	1,904,041	423,424,581	37,633,981	8,214,536	2,038,487	2,755,263	316,321	514,561,719	54,013,533
1883	42,314,028	1,755,154,376	50,015,337	4,439,097	17,365,334	1,915,045	450,160,690	39,470,351	10,108,934	2,193,245	4,609,524	375,263	533,145,429	57,663,074
1884	51,548,795	1,987,643,976	57,679,339	6,102,810	13,676,421	1,132,538	433,851,278	39,450,794	11,985,219	2,443,385	6,503,298	327,599	544,495,608	60,595,186
1885	58,064,841	1,718,739,529	81,433,609	6,040,685	14,739,469	1,160,999	443,880,518	39,470,082	13,978,959	2,659,210	8,274,767	560,784,609	49,671,713	
1886	58,233,433	1,159,700,262	70,346,480	5,068,409	14,471,951	1,264,736	488,216,680	39,017,922	15,348,367	3,689,464	1,993,824	501,884,307	48,145,204	
1887	67,612,025	1,159,700,262	70,346,480	5,068,409	14,471,951	1,264,736	488,216,680	39,017,922	15,348,367	3,689,464	1,993,824	501,884,307	48,145,204	
1888	55,163,513	1,159,700,262	70,346,480	5,068,409	14,471,951	1,264,736	488,216,680	39,017,922	15,348,367	3,689,464	1,993,824	501,884,307	48,145,204	
1889	45,823,572	1,159,700,262	70,346,480	5,068,409	14,471,951	1,264,736	488,216,680	39,017,922	15,348,367	3,689,464	1,993,824	501,884,307	48,145,204	
1890	54,292,637	1,159,700,262	70,346,480	5,068,409	14,471,951	1,264,736	488,216,680	39,017,922	15,348,367	3,689,464	1,993,824	501,884,307	48,145,204	
1891	50,509,657	1,159,700,262	70,346,480	5,068,409	14,471,951	1,264,736	488,216,680	39,017,922	15,348,367	3,689,464	1,993,824	501,884,307	48,145,204	
1892	48,431,066	1,159,700,262	70,346,480	5,068,409	14,471,951	1,264,736	488,216,680	39,017,922	15,348,367	3,689,464	1,993,824	501,884,307	48,145,204	
1893	49,344,516	1,159,700,262	70,346,480	5,068,409	14,471,951	1,264,736	488,216,680	39,017,922	15,348,367	3,689,464	1,993,824	501,884,307	48,145,204	
1894	52,892,276	1,159,700,262	70,346,480	5,068,409	14,471,951	1,264,736	488,216,680	39,017,922	15,348,367	3,689,464	1,993,824	501,884,307	48,145,204	
1895	60,960,361	1,159,700,262	70,346,480	5,068,409	14,471,951	1,264,736	488,216,680	39,017,922	15,348,367	3,689,464	1,993,824	501,884,307	48,145,204	
1896	60,475,616	1,159,700,262	70,346,480	5,068,409	14,471,951	1,264,736	488,216,680	39,017,922	15,348,367	3,689,464	1,993,824	501,884,307	48,145,204	
1897	55,364,233	1,159,700,262	70,346,480	5,068,409	14,471,951	1,264,736	488,216,680	39,017,922	15,348,367	3,689,464	1,993,824	501,884,307	48,145,204	
1898	57,070,850	1,159,700,262	70,346,480	5,068,409	14,471,951	1,264,736	488,216,680	39,017,922	15,348,367	3,689,464	1,993,824	501,884,307	48,145,204	
1899	63,630,829	1,159,700,262	70,346,480	5,068,409	14,471,951	1,264,736	488,216,680	39,017,922	15,348,367	3,689,464	1,993,824	501,884,307	48,145,204	
1900 <sup>a</sup>	69,389,194	1,159,700,262	70,346,480	5,068,409	14,471,951	1,264,736	488,216,680	39,017,922	15,348,367	3,689,464	1,993,824	501,884,307	48,145,204	
1901	88,766,916	1,159,700,262	70,346,480	5,068,409	14,471,951	1,264,736	488,216,680	39,017,922	15,348,367	3,689,464	1,993,824	501,884,307	48,145,204	
1902 <sup>b</sup>	100,461,337	1,159,700,262	70,346,480	5,068,409	14,471,951	1,264,736	488,216,680	39,017,922	15,348,367	3,689,464	1,993,824	501,884,307	48,145,204	
1903	117,063,421	1,159,700,262	70,346,480	5,068,409	14,471,951	1,264,736	488,216,680	39,017,922	15,348,367	3,689,464	1,993,824	501,884,307	48,145,204	
1904	134,717,680	1,159,700,262	70,346,480	5,068,409	14,471,951	1,264,736	488,216,680	39,017,922	15,348,367	3,689,464	1,993,824	501,884,307	48,145,204	
1905	156,095,335	1,159,700,262	70,346,480	5,068,409	14,471,951	1,264,736	488,216,680	39,017,922	15,348,367	3,689,464	1,993,824	501,884,307	48,145,204	
1906	184,497,357	1,159,700,262	70,346,480	5,068,409	14,471,951	1,264,736	488,216,680	39,017,922	15,348,367	3,689,464	1,993,824	501,884,307	48,145,204	
1907	222,617,357	1,159,700,262	70,346,480	5,068,409	14,471,951	1,264,736	488,216,680	39,017,922	15,348,367	3,689,464	1,993,824	501,884,307	48,145,204	
1908	183,170,874	1,159,700,262	70,346,480	5,068,409	14,471,951	1,264,736	488,216,680	39,017,922	15,348,367	3,689,464	1,993,824	501,884,307	48,145,204	
1909	178,527,355	1,159,700,262	70,346,480	5,068,409	14,471,951	1,264,736	488,216,680	39,017,922	15,348,367	3,689,464	1,993,824	501,884,307	48,145,204	
1910	209,567,248	1,159,700,262	70,346,480	5,068,409	14,471,951	1,264,736	488,216,680	39,017,922	15,348,367	3,689,464	1,993,824	501,884,307	48,145,204	
1911	220,449,391	1,159,700,262	70,346,480	5,068,409	14,471,951	1,264,736	488,216,680	39,017,922	15,348,367	3,689,464	1,993,824	501,884,307	48,145,204	
1912	222,935,044	1,159,700,262	70,346,480	5,068,409	14,471,951	1,264,736	488,216,680	39,017,922	15,348,367	3,689,464	1,993,824	501,884,307	48,145,204	
1913	248,446,235	1,159,700,262	70,346,480	5,068,409	14,471,951	1,264,736	488,216,680	39,017,922	15,348,367	3,689,464	1,993,824	501,884,307	48,145,204	
1914	265,672,536	1,159,700,262	70,346,480	5,068,409	14,471,951	1,264,736	488,216,680	39,017,922	15,348,367	3,689,464	1,993,824	501,884,307	48,145,204	
1915	301,104,104	1,159,700,262	70,346,480	5,068,409	14,471,951	1,264,736	488,216,680	39,017,922	15,348,367	3,689,464	1,993,824	501,884,307	48,145,204	
1916	300,767,168	1,159,700,262	70,346,480	5,068,409	14,471,951	1,264,736	488,216,680	39,017,922	15,348,367	3,689,464	1,993,824	501,884,307	48,145,204	
1917	335,315,601	1,159,700,262	70,346,480	5,068,409	14,471,951	1,264,736	488,216,680	39,017,922	15,348,367	3,689,464	1,993,824	501,884,307	48,145,204	
1918	355,927,716	1,159,700,262	70,346,480	5,068,409	14,471,951	1,264,736	488,216,680	39,017,922	15,348,367	3,689,464	1,993,824	501,884,307	48,145,204	

*Note.*—In the foregoing table, the gallons are American gallons (100 American gallons = 83.3 Imperial gallons). *b* Including all petroleum produced in Kentucky and Tennessee before 1883. *c* Exports are for fiscal years from 1893 to 1896 inclusive. *d* In addition to this amount, 4295 barrels of crude oil were produced in Kentucky and Tennessee in 1896, 4377 barrels in 1897, 19,162 barrels in 1898, and 15,978 barrels in 1899, for which, as none was sold, no value could be given. *e* Includes 41,405 barrels of oil sold in Kentucky and Tennessee in 1900, but produced in previous years. *f* In addition to this amount, 593,386 barrels were produced but not marketed.

## PRODUCTION IN UNITED STATES.

QUANTITY, TOTAL VALUE, AND AVERAGE PRICE PER BARREL OF PETROLEUM MARKETED IN THE UNITED STATES,  
BY FIELDS, IN 1917 AND 1918.

Field.	1917.			1918.		
	Quantity. U.S.A. Barrels of 42 Gallons.	Value. Dollars.	Average Price per Barrel. Dollars.	Quantity. U.S.A. Barrels of 42 Gallons.	Value. Dollars.	Average Price per Barrel. Dollars.
Appalachian, . . . . .	24,932,205	77,786,495	3-120	25,401,466	93,917,171	3-697
Lima-Indiana, . . . . .	3,670,293	7,102,326	1-935	3,230,722	7,450,932	2-313
Illinois, . . . . .	15,776,860	31,358,069	1-988	13,365,974	31,230,000	2-337
Mid-Continent, . . . . .	163,506,205	282,796,124	1-730	179,383,098	393,031,158	2-191
Gulf, . . . . .	24,342,879	26,087,587	1-071	24,207,620	41,053,846	1-696
California, . . . . .	93,877,549	86,161,764	-918	97,531,997	118,770,790	1-218
Rocky Mountain, . . . . .	9,199,310	11,322,248	1-231	12,808,896	18,474,078	1-442
Other fields, . . . . .	$\alpha$ 10,300	$\alpha$ 20,600	2-000	$\alpha$ 7,943	$\alpha$ 15,986	2-013
Total, . . . . .	335,315,601	522,635,213	1-559	355,927,716	703,943,961	1-978

$\alpha$  Alaska and Michigan.

PRODUCTION OF CRUDE PETROLEUM IN PENNSYLVANIA AND  
NEW YORK FROM 1905 TO 1918.

(In Barrels of 42 American Gallons.)

Year.	Pennsylvania.	New York.
	Quantity.	Quantity.
1905, . . . . .	10,437,195	1,117,582
1906, . . . . .	10,256,893	1,243,517
1907, . . . . .	9,999,306	1,212,300
1908, . . . . .	9,424,325	1,160,128
1909, . . . . .	9,299,403	1,134,897
1910, . . . . .	8,794,662	1,053,838
1911, . . . . .	8,248,158	952,515
1912, . . . . .	7,837,948	874,128
1913, . . . . .	7,917,302	948,191
1914, . . . . .	8,170,335	938,974
1915, . . . . .	7,838,705	887,778
1916, . . . . .	7,592,394	874,087
1917, . . . . .	7,733,200	879,685
1918, . . . . .	7,407,812	808,843

## APPALACHIAN PIPE-LINE RUNS.

 PIPE-LINE RUNS BY THE PRINCIPAL PIPE-LINE COMPANIES IN THE APPALACHIAN OIL-FIELD FROM 1905 TO 1918.  
 (In Barrels of 42 American Gallons.)

Name of Company.	1905.	1906.	1907.	1908.	1909.	1910.	1911.	1912.	1913.	1914.	1915.	1916.	1917.	1918.
National Transit, . . . . .	4,988,761	4,863,303	4,619,223	4,406,257	4,337,274	3,839,504	3,366,961	2,939,549	2,707,525	2,722,518	2,695,140	2,577,166	2,523,011	2,349,656
Eureka, . . . . .	11,074,759	9,568,822	8,458,285	8,769,986	9,997,273	11,014,897	9,187,952	11,499,665	10,764,342	8,986,601	8,638,851	7,737,768	7,144,680	6,267,524
South-West, . . . . .	2,425,324	2,267,674	2,102,197	1,885,944	1,675,086	1,636,455	1,616,886	1,456,437	1,340,517	1,385,119	1,300,732	1,276,033	1,467,582	1,288,899
Tidewater, . . . . .	1,721,689	1,709,142	1,614,954	1,539,169	1,531,047	1,430,794	1,344,203	1,243,062	1,267,249	1,316,004	1,323,128	1,315,694	1,378,423	1,452,769
Producers' and Refiners, <sup>a</sup>	2,040,782	2,771,385	2,684,678	2,427,475	2,459,767	2,280,009	2,088,531	2,081,535	2,451,131	2,271,638	2,063,189	2,076,509	1,893,566	1,660,587
Emery, . . . . .	295,716	304,372	307,521	309,228	350,824	348,525	335,933	317,713	333,935	357,263	338,585	336,453	323,805	319,786
United States, . . . . .	50,028	..	..	..	..	..	..	..	..	..	..	..	..	..
Franklin, . . . . .	36,947	37,389	42,085	42,362	43,676	43,304	44,612	37,014	36,961	36,843	41,340	36,228	32,466	32,087
Cumberland, . . . . .	1,210,821	1,100,779	764,023	693,418	595,506	463,526	468,313	475,546	522,553	479,610	407,083	1,144,732	3,027,836	4,034,961
New York Transit, . . . . .	..	128,083	289,506	273,713	216,391	196,768	187,825	182,291	196,510	203,857	185,411	174,503	168,013	157,350
Buckeye-Macksburg, . . . . .	4,235,007	2,060,454	2,894,103	3,044,284	3,762,472	4,005,146	3,458,023	4,084,071	3,558,962	3,484,261	3,265,334	3,346,637	3,545,661	3,449,855
Other Pipe-Lines, . . . . .	..	2,930,059	1,565,612	1,553,681	1,566,928	1,632,451	1,650,593	2,021,633	2,739,100	2,907,354	2,871,255	2,987,712	3,427,162	4,448,002
Total, . . . . .	28,080,834	27,741,473	25,342,137	24,945,517	26,535,844	26,891,379	23,749,832	26,238,516	25,921,785	24,101,048	22,860,048	23,009,455	24,332,205	25,401,466

<sup>a</sup> For the last five months of the year the runs of this Company are included in "Other Pipe Lines."

TOTAL AMOUNT AND VALUE OF CRUDE PETROLEUM PRODUCED IN OHIO FROM 1889 TO 1918.

Year.	Lima District.		South-eastern Ohio District.		Mecca-Belden District.		Total.	
	Pro-duction.	Value.	Pro-duction.	Value.	Pro-duction.	Value.	Pro-duction.	Value.
	Barrels.	\$	Barrels.	\$	Barrels.	\$	Barrels.	\$
1889	12,153,189	1,822,978	317,037	340,683	1,240	10,334	12,471,466	2,173,995
1890	15,014,882	4,504,465	1,108,334	1,127,730	1,440	12,000	16,124,666	5,644,195
1891	17,315,978	5,281,373	422,883	283,332	1,440	12,000	17,740,301	5,576,705
1892	15,169,507	5,555,832	1,190,302	662,106	3,112	21,101	16,362,921	6,239,039
1893	13,646,804	6,448,115	2,601,394	1,664,892	1,571	11,335	16,249,709	8,124,342
1894	13,607,844	6,531,765	3,183,370	2,670,052	940	4,476	16,792,154	9,206,293
1895	15,850,609	11,372,812	3,693,248	5,018,201	1,376	8,229	19,545,233	16,399,242
1896	20,575,138	13,723,617	3,365,365	3,966,924	666	2,897	23,941,169	17,693,438
1897	18,682,677	8,967,685	2,877,193	2,262,193	645	3,120	21,560,515	11,232,998
1898	16,590,416	10,244,582	2,147,610	1,957,010	682	3,618	18,738,708	12,205,210
1899	16,377,174	14,718,985	4,764,135	6,243,075	799	4,244	21,142,108	20,966,304
1900	16,884,358	16,673,304	5,476,089	7,406,734	2,283	11,563	22,362,730	24,091,601
1901	16,176,293	13,911,612	5,470,850	6,619,342	940	2,617	21,648,083	20,533,571
1902	15,877,730	14,284,072	5,136,366	6,471,821	135	1,466	21,014,231	20,757,359
1903	14,893,853	17,351,339	5,585,858	8,881,514	575	1,668	20,480,286	26,234,521
1904	13,350,060	14,735,129	5,526,145	8,993,803	425	1,583	18,876,631	23,730,515
1905	11,329,924	10,061,992	5,016,646	6,991,950	90	935	16,346,660	17,054,877
1906	9,881,184	9,157,641	4,906,399	7,838,387	180	972	14,787,763	16,997,000
1907	7,993,057	7,425,480	4,214,298	7,343,943	93	465	12,207,448	14,769,888
1908	6,748,676	6,861,885	4,109,935	7,315,667	186	950	10,858,797	14,178,502
1909	5,915,357	5,451,497	4,717,069	7,771,555	367	2,325	10,632,793	13,225,377
1910	5,094,136	4,181,629	4,822,234	6,469,939	..	..	9,916,370	10,651,568
1911	4,535,875	3,888,119	4,281,237	5,591,423	..	..	8,817,112	9,479,542
1912	3,955,897	3,908,809	5,013,110	8,177,189	..	..	8,969,007	12,085,998
1913	3,817,043	5,308,842	4,964,425	12,229,610	..	..	8,781,468	17,538,452
1914	3,727,087	4,435,314	4,809,265	8,937,415	..	..	8,536,352	13,372,729
1915	3,393,833	3,300,833	4,431,493	6,760,660	..	..	7,825,326	10,061,493
1916	3,135,967	4,909,704	4,608,544	11,245,236	..	..	7,744,511	16,154,940
1917	2,910,861	5,631,778	4,839,679	15,472,705	..	..	7,750,540	21,104,483
1918	2,343,164	5,422,803	4,941,841	18,042,394	..	..	7,285,005	23,465,197

TOTAL AMOUNT AND VALUE OF CRUDE PETROLEUM PRODUCED IN WEST VIRGINIA  
FROM 1889 TO 1918 INCLUSIVE.

Year.	Regular Crude.			Lubricating Crude.			Total.		
	Pro- duction.	Value.	Price per Barrel.	Pro- duction.	Value.	Price per Barrel.	Pro- duction.	Value.	Price per Barrel.
	Barrels.	\$	\$	Barrels.	\$	\$	Barrels.	\$	\$
1889	520,511	595,730	1.145	23,602	58,097	2.46½	544,113	653,827	1.20½
1890	..	..	..	..	..	..	492,578	501,198	1.01½
1891	..	..	..	..	..	..	2,406,218	1,612,826	.67
1892	..	..	..	..	..	..	3,810,086	2,119,901	.556
1893	8,433,412	5,398,522	.64	12,000	27,000	2.25	8,445,412	5,425,522	.64
1894	8,563,954	7,182,794	.839	13,670	38,923	2.85	8,577,624	7,221,717	.84
1895	8,109,782	11,017,651	1.35½	10,343	21,119	2.04	8,120,125	11,038,770	1.36
1896	10,005,966	11,794,532	1.17½	13,804	35,086	2.54	10,019,770	11,829,618	1.18
1897	13,078,011	10,282,586	.78½	12,034	27,592	2.29	13,090,045	10,310,178	.78½
1898	13,603,136	12,395,858	.91½	11,965	30,501	2.55	13,615,101	12,426,359	.913
1899	13,892,906	17,973,947	1.29½	17,724	40,819	2.303	13,910,630	18,014,766	1.295
1900	16,176,757	21,879,064	1.35½	18,918	43,638	2.307	16,195,675	21,922,702	1.353
1901	14,164,662	17,139,241	1.21	12,464	33,483	2.687	14,177,126	17,172,724	1.211
1902	13,498,685	17,006,469	1.26	14,660	33,848	2.309	13,513,345	17,040,317	1.261
1903	12,893,079	20,499,996	1.59	6,316	16,536	2.62	12,899,395	20,516,532	1.59
1904	12,636,253	20,557,556	1.627	8,433	26,225	3.11	12,644,686	20,583,781	1.628
1905	11,573,545	16,117,816	1.393	4,565	14,815	3.25	11,578,110	16,132,631	1.393
1906	10,111,647	16,138,811	1.596	9,288	31,482	3.39	10,120,935	16,170,293	1.598
1907	9,089,839	15,834,714	1.74	5,457	17,714	3.25	9,095,296	15,852,428	1.743
1908	9,519,875	16,902,968	1.775	3,301	8,897	2.70	9,523,176	16,911,865	1.776
1909	10,742,026	17,634,335	1.642	3,066	7,948	2.59	10,745,092	17,642,283	1.642
1910	11,751,018	15,717,796	1.338	2,053	5,748	2.80	11,753,071	15,723,544	1.338
1911	9,792,324	12,757,861	1.302	3,140	9,432	3.00	9,795,464	12,767,293	1.303
1912	12,126,137	19,919,952	1.643	2,825	7,769	2.75	12,128,962	19,927,721	1.643
1913	11,562,730	28,813,822	2.492	4,569	14,982	3.28	11,567,299	28,828,814	2.492
1914	9,677,553	18,462,175	1.908	2,480	6,365	2.56	9,680,033	18,468,540	1.908
1915	9,260,914	14,458,513	1.561	3,884	9,765	2.51	9,264,798	14,468,278	1.561
1916	8,727,930	21,904,236	2.510	3,254	9,844	3.03	8,731,184	21,914,080	2.510
1917	8,377,697	27,240,608	3.252	1,588	6,352	4.00	8,379,285	27,246,960	3.252
1918	7,864,630	31,643,685	4.024	1,998	8,333	4.171	7,866,628	31,652,018	4.024

EXPORTS OF CRUDE PETROLEUM AND PETROLEUM PRODUCTS FROM THE UNITED STATES, IN GALLONS  
(AMERICAN), FOR THE FISCAL YEARS 1903 TO 1918, EACH YEAR ENDING JUNE 30TH.  
(Compiled by the Bureau of Statistics of the United States Treasury Department.)

COUNTRIES.	1903.	1904.	1905.	1906.	1907.	1908.	1909.	1910.
<b>CRUDE.</b>								
<i>Europe—</i>								
Belgium, . . . . .	..	..	..	..	897,370	52	201,107	104
France, . . . . .	82,192,041	66,212,481	47,015,325	55,103,511	47,777,692	40,555,219	33,168,985	13,087,508
Germany, . . . . .	6,338,191	3,990,063	5,669,934	6,543,989	4,936,082	6,485,413	..	..
Netherlands, . . . . .	..	1,266,406	774,085	..	..	..	..	..
Spain, . . . . .	11,095,516	8,066,482	11,822,756	13,490,077	8,603,703	9,526,563	10,038,730	9,691,256
United Kingdom, . . . . .	17,769,325	12,021,922	14,075,577	19,131,352	12,660,797	8,934,223	24,590,204	..
Other countries, . . . . .	8,166	100	529	1,250	150	2,470	511	..
<b>Total, . . . . .</b>	<b>117,403,239</b>	<b>91,557,224</b>	<b>79,358,206</b>	<b>94,270,179</b>	<b>74,875,794</b>	<b>65,503,940</b>	<b>67,999,537</b>	<b>22,778,868</b>
<i>North America—</i>								
Mexico, . . . . .	9,859,154	10,938,441	14,036,517	14,366,495	19,992,434	17,523,440	27,554,581	41,202,786
Cuba, . . . . .	5,119,813	6,212,648	7,440,234	6,266,626	5,385,898	5,040,720	5,493,314	4,713,586
Dominion of Canada, . . . . .	..	..	22,200,665	23,882,943	22,571,811	28,577,508	35,366,004	39,222,019
Panama, . . . . .	..	..	..	27,963	3,398,100	5,562,745	13,250,620	26,597,900
Porto Rico, . . . . .	..	..	..	..	..	..	..	..
Other countries, . . . . .	2,505,014	5,865,728	3,073	45,192	5,305,767	906,405	1,899,204	4,004,453
<b>Total, . . . . .</b>	<b>17,483,981</b>	<b>23,016,790</b>	<b>43,700,439</b>	<b>44,561,256</b>	<b>53,255,910</b>	<b>57,610,818</b>	<b>83,563,723</b>	<b>115,740,744</b>
<i>South America, . . . . .</i>								
Japan, . . . . .	..	..	315	850,180	23,200	3,365,728	10,182,832	30,353,669
All other countries, . . . . .	4,950	2,906	..	7,000	1,075	8,742,789	8,102,423	30,704
<b>Total crude, . . . . .</b>	<b>134,892,170</b>	<b>114,576,920</b>	<b>123,059,010</b>	<b>139,688,615</b>	<b>128,175,737</b>	<b>135,223,575</b>	<b>169,855,309</b>	<b>168,903,985</b>
<b>REFINED.</b>								
<i>Naphthas.</i>								
<i>Europe—</i>								
France, . . . . .	5,550,675	7,147,327	8,980,020	8,417,101	5,623,747	10,485,796	23,553,067	6,583,457
Germany, . . . . .	1,866,357	..	3,253,042	3,782,176	492,865	2,074	750,000	11,394,253
Netherlands, . . . . .	..	..	..	..	..	..	..	..
Sweden, . . . . .	..	..	268,354	259,648	326,045	1,267,611	378,558	522,680
United Kingdom, . . . . .	2,376,877	5,942,545	11,806,289	12,888,828	7,222,433	6,943,892	16,148,285	16,924,159
Other countries, . . . . .	295,713	6291,124	2,393,251	1,884,941	3,016,619	2,701,661	4,623,663	12,419,372
<b>Total, . . . . .</b>	<b>10,089,622</b>	<b>13,380,996</b>	<b>26,705,956</b>	<b>27,282,694</b>	<b>16,691,709</b>	<b>21,301,034</b>	<b>45,453,573</b>	<b>47,843,901</b>
<i>North America, . . . . .</i>								
West Indies, . . . . .	1,642,869	2,198,312	1,645,855	1,980,814	4,770,891	7,994,179	8,704,588	17,320,657
South America, . . . . .	23,231	34,601	32,042	80,338	131,825	132,171	310,241	320,160
Asia and Oceania, . . . . .	292,066	298,769	502,955	1,095,499	1,934,204	2,499,971	3,690,656	5,785,161
Africa, . . . . .	913,356	794,264	1,572,965	1,664,071	2,214,135	3,588,815	4,602,975	5,210,862
Other countries, . . . . .	178,104	203,179	356,832	703,278	614,290	726,700	1,069,234	1,170,182
<b>Total, . . . . .</b>	<b>3,049,606</b>	<b>3,529,125</b>	<b>4,110,699</b>	<b>5,524,000</b>	<b>9,665,345</b>	<b>14,941,336</b>	<b>18,377,694</b>	<b>29,807,022</b>
<b>Total Naphthas, . . . . .</b>	<b>13,139,228</b>	<b>16,910,121</b>	<b>30,816,655</b>	<b>32,756,694</b>	<b>26,357,054</b>	<b>36,242,370</b>	<b>63,831,267</b>	<b>77,650,923</b>
<i>Illuminating Oil.</i>								
<i>Europe—</i>								
Belgium, . . . . .	44,141,816	38,569,610	39,526,415	43,478,987	47,942,197	48,597,412	54,429,995	41,287,412
Denmark, . . . . .	17,566,033	22,162,981	15,550,986	18,120,251	16,123,410	17,873,509	20,985,008	20,238,497
France, . . . . .	5,326,633	3,843,627	9,875,889	22,739,414	32,652,548	62,752,810	64,534,115	46,924,343
Germany, . . . . .	111,336,427	113,069,001	136,577,304	110,336,514	120,183,398	151,802,286	151,269,633	151,890,625
Italy, . . . . .	94,175,999	12,736,187	23,043,026	28,979,309	22,627,583	22,920,445	23,355,053	26,057,918
Netherlands, . . . . .	116,817,141	111,338,359	110,037,453	123,208,276	113,779,776	126,335,611	134,656,827	121,808,987
Sweden and Nor- way, . . . . .	24,914,630	28,588,783	25,447,181	25,626,562	29,799,154	37,738,705	43,186,026	37,187,417
United Kingdom, . . . . .	149,281,493	165,248,727	174,057,928	190,383,239	182,328,955	206,875,262	223,313,293	194,226,610
Portugal, . . . . .	3,069,654	1,466,082	4,432,064	6,021,243	5,265,000	7,759,197	5,999,563	5,751,226
Other countries, . . . . .	2,858,717	1,417,570	1,336,875	3,569,867	1,395,847	4,002,069	3,182,583	4,191,054
<b>Total, . . . . .</b>	<b>499,438,543</b>	<b>498,430,827</b>	<b>529,939,821</b>	<b>572,463,662</b>	<b>572,077,868</b>	<b>676,663,280</b>	<b>704,942,696</b>	<b>649,564,089</b>
<i>North America—</i>								
British North America, . . . . .	18,485,915	20,085,691	13,767,128	11,263,304	10,088,253	6,196,631	13,824,783	10,201,902
Central America, Mexico, . . . . .	1,057,131	1,331,845	1,462,787	2,014,071	2,014,242	2,424,129	2,317,303	2,590,288
West Indies, . . . . .	342,000	409,266	461,266	2,095,939	2,495,070	764,067	511,276	740,615
British, Other W. Indies, Other countries, . . . . .	2,891,930	2,438,025	2,538,784	2,679,322	2,878,322	2,777,266	2,859,903	3,002,377
	2,723,404	2,912,099	3,728,017	2,901,690	3,264,340	2,885,360	2,143,867	3,447,741
	622,370	683,418	709,500	573,702	512,331	653,375	683,674	669,073
<b>Total, . . . . .</b>	<b>26,122,750</b>	<b>27,910,344</b>	<b>22,667,482</b>	<b>21,528,028</b>	<b>21,252,558</b>	<b>15,700,818</b>	<b>22,340,706</b>	<b>20,651,946</b>

<sup>a</sup> Of this amount, 5,862,148 gallons was exported to Canada.

<sup>b</sup> Of this amount, 234,302 gallons was exported to Sweden.

## EXPORTS OF CRUDE PETROLEUM AND PETROLEUM PRODUCTS—continued.

COUNTRIES.	1911.	1912.	1913.	1914.	1915.	1916.	1917.	1918.
<b>CRUDE.</b>								
Europe—								
Belgium, . . . . .	..	2,268	5,502	..	..	..	..	..
France, . . . . .	21,843,880	36,993,936	24,531,864	10,284,498	721,434	6,885,978	331,884	..
Germany, . . . . .	17,500	11,650	9,996	..	..	..	..	..
Netherlands, . . . . .	..	..	..	..	..	..	..	..
Spain, . . . . .	11,016,697	9,431,862	12,902,484	11,455,290	6,720,168	2,498,916	2,462,124	3,889,074
United Kingdom, . . . . .	220	4,068,288	1,116,738	..	..	..	..	..
Other countries, . . . . .	..	1,000,020	19,992	2,311,764	4,181,352	1,776,474	318,822	1,035,972
Total, . . . . .	33,478,297	61,507,624	38,586,576	24,051,552	11,622,954	10,861,368	3,112,830	4,925,046
North America—								
Mexico, . . . . .	24,398,337	22,752,576	16,138,920	9,207,534	10,132,668	7,972,482	2,004,450	2,192,778
Cuba, . . . . .	5,228,400	4,993,288	5,361,552	8,178,912	9,837,198	13,137,726	11,030,502	8,593,578
Dominion of Canada, . . . . .	52,260,863	76,324,752	124,720,050	63,356,244	109,096,848	124,599,678	139,832,952	184,598,442
Panama, . . . . .	38,958,000	28,084,896	4,494	126	2,327,934	462	1,752,660	..
Porto Rico, . . . . .	..	..	..	..	..	..	..	..
Other Countries, . . . . .	3,052,568	1,946,112	17,598	..	..	..	..	..
Total, . . . . .	123,898,186	133,701,624	146,242,614	80,742,816	131,394,648	145,710,348	154,620,564	195,384,798
South America, . . . . .	27,794,095	22,839,348	10,717,434	7,270,956	1,368,780	2,312,688	2,362,290	18,438
Japan, . . . . .	..	..	..	..	..	..	..	..
All other countries, . . . . .	20,183	61,782	96,306	12,670,224	13,876,674	13,143,480	12,025,524	5,500,740
Total crude, . . . . .	185,190,761	208,110,378	195,642,930	124,738,548	158,263,056	172,027,884	172,121,208	205,829,022
<b>REFINED.</b>								
<i>Gasoline.</i>								
Europe—								
Belgium, . . . . .	..	..	..	2,688,528	..	..	..	..
France, . . . . .	..	..	3,494,604	32,367,031	14,256,497	44,405,796	56,066,313	104,667,824
Germany, . . . . .	..	..	1,942,746	3,752,361	..	..	..	..
Italy, . . . . .	..	..	..	7,164,733	3,651,600	8,241,455	30,686,430	49,603,064
Netherlands, . . . . .	..	..	4,007,592	5,513,450	535,911	153,290	1,106,642	..
United Kingdom, . . . . .	..	..	6,049,646	36,023,611	18,928,206	45,530,888	54,574,416	121,294,920
Other countries, . . . . .	..	..	2,048,357	7,504,190	5,619,013	10,655,908	5,752,850	5,568,429
Total, . . . . .	..	..	17,542,945	95,014,904	43,091,227	108,987,332	148,186,651	281,134,237
North America, . . . . .	..	..	61,932,234	..	..	..	..	..
Canada, . . . . .	..	..	..	33,457,063	33,874,220	25,312,456	27,647,086	26,093,644
South America, . . . . .	..	..	8,652,143	..	..	..	..	..
Argentina, . . . . .	..	..	..	11,785,439	10,348,542	2,579,281	4,398,606	1,870,540
Brazil, . . . . .	..	..	..	3,221,967	7,593,380	7,470,287	6,990,302	3,746,373
Africa, . . . . .	..	..	1,614,794	..	..	..	..	..
Asia and Oceania, . . . . .	..	..	1,956,801	..	..	..	..	..
British Oceania, . . . . .	..	..	..	6,519,747	8,163,752	9,237,065	15,655,165	18,818,834
Other countries, . . . . .	..	..	..	12,670,918	9,491,808	14,341,841	21,933,681	20,303,536
Total Gasoline, . . . . .	..	..	81,698,917	162,670,038	112,562,929	167,928,262	224,811,491	351,967,164
<i>Naphthas.</i>								
Europe—								
France, . . . . .	8,570,396	25,026,916	16,491,593	..	..	..	..	..
Germany, . . . . .	7,668,059	15,317,517	12,926,229	..	..	..	..	..
Sweden, . . . . .	702,010	1,283,881	1,471,525	..	..	..	..	..
United Kingdom, . . . . .	23,332,440	26,820,738	13,426,820	..	..	..	..	..
Other countries, . . . . .	20,487,537	30,877,612	22,046,570	..	..	..	..	..
Total, . . . . .	65,760,442	99,926,644	66,362,737	..	..	..	..	..
North America, . . . . .	24,173,133	35,213,601	4,118,900	..	..	..	..	..
West Indies, . . . . .	539,065	856,510	265,424	..	..	..	..	..
South America, . . . . .	11,047,387	18,933,132	15,360,440	..	..	..	..	..
Asia and Oceania, . . . . .	8,339,291	13,707,125	11,766,558	..	..	..	..	..
Africa, . . . . .	2,138,942	2,403,118	3,947,513	..	..	..	..	..
Total, . . . . .	46,237,818	71,113,486	35,458,835	..	..	..	..	..
Total Naphthas, . . . . .	111,998,260	171,040,130	101,821,572	47,023,617	169,046,152	187,942,021	191,067,353	207,401,691
<i>Illuminating Oil.</i>								
Europe—								
Belgium, . . . . .	51,194,876	47,032,277	58,831,411	129,109,083	..	..	..	..
Denmark, . . . . .	23,494,756	29,966,403	30,104,209	34,449,970	28,583,368	32,439,735	8,818,950	4,917,133
France, . . . . .	45,322,937	37,702,251	52,953,474	63,140,502	77,630,112	92,112,121	73,948,069	78,491,864
Germany, . . . . .	106,405,766	92,289,677	103,983,882	39,358,058	..	..	..	..
Italy, . . . . .	23,915,541	30,469,655	21,182,834	31,688,719	30,398,605	37,522,438	31,137,116	25,952,679
Netherlands, . . . . .	102,904,032	112,747,606	134,204,916	137,593,350	60,078,821	55,816,443	17,796,759	..
Sweden and Norway, . . . . .	43,055,997	39,681,438	43,376,319	25,604,742	26,316,321	27,762,077	11,439,719	9,454,014
United Kingdom, . . . . .	164,599,861	166,215,650	169,288,659	156,744,206	161,901,460	151,903,144	171,313,137	163,549,730
Portugal, . . . . .	3,958,728	6,710,191	6,640,313	..	..	..	..	..
Other countries, . . . . .	3,352,915	7,180,070	5,633,149	36,695,402	46,868,634	59,049,392	36,686,214	25,379,863
Total, . . . . .	568,804,509	569,995,268	626,249,166	654,394,032	431,777,321	456,605,350	351,139,264	307,745,288
North America—								
British North America, . . . . .	11,257,460	15,605,516	18,226,258	7,898,165	6,292,171	9,736,254	17,395,638	6,036,100
Central America, . . . . .	3,413,245	2,494,184	4,086,746	..	..	..	..	..
Mexico, . . . . .	200,252	165,396	1,225,289	..	..	..	..	..
Cuba, . . . . .	..	..	..	196,654	242,761	1,448,875	1,082,739	5,783,038
West Indies, . . . . .	..	..	..	6,787,871	6,024,079	6,506,134	6,913,092	5,046,925
British, . . . . .	..	..	..	..	..	..	..	..
Other W. Indies, . . . . .	3,164,053	3,558,767	3,184,152	..	..	..	..	..
Other countries, . . . . .	4,031,921	2,960,860	5,318,112	..	..	..	..	..
Total, . . . . .	856,697	911,203	1,004,131	..	..	..	..	..
Total, . . . . .	22,903,533	25,675,926	33,044,638	14,822,690	12,559,011	17,691,263	25,391,469	16,866,071



## EXPORTS OF CRUDE PETROLEUM AND PETROLEUM PRODUCTS—continued.

COUNTRIES.	1903.	1904.	1905.	1906.	1907.	1908.	1909.	1910.
<b>South America—</b>								
Argentina, . . .	12,107,291	12,216,938	15,818,832	14,430,159	14,900,929	18,532,187	16,384,837	18,490,512
Brazil, . . . . .	20,116,287	19,403,726	21,389,827	24,198,146	24,528,640	24,359,423	27,999,696	29,874,870
Chile, . . . . .	4,679,976	5,756,672	5,945,330	7,263,136	5,842,470	6,250,448	8,264,431	8,059,982
Uruguay, . . . . .	3,027,675	3,185,700	2,918,600	4,286,600	4,875,966	5,158,182	5,154,920	7,009,158
Venezuela, . . . .	825,059	1,263,622	1,259,776	1,236,512	1,422,441	1,207,665	1,372,075	1,444,847
Other countries, . .	3,026,178	3,772,257	3,391,885	3,520,193	3,510,906	3,557,761	3,608,333	3,546,848
<b>Total, . . . . .</b>	<b>43,782,466</b>	<b>45,598,915</b>	<b>50,724,250</b>	<b>54,934,746</b>	<b>55,081,352</b>	<b>59,065,666</b>	<b>62,679,292</b>	<b>68,426,217</b>
<b>Asia—</b>								
China, . . . . .	19,321,930	40,614,179	89,368,014	54,376,377	77,913,487	103,737,770	87,006,468	65,817,980
Hong Kong, . . . .	16,971,990	22,308,570	18,660,090	5,561,590	12,048,815	11,107,670	10,370,460	12,692,037
<b>East Indies—</b>								
British, . . . . .	10,130,090	9,667,103	24,853,070	38,204,743	37,837,841	39,173,434	42,949,022	37,545,823
Dutch, . . . . .	9,210,520	10,924,890	9,798,770	12,039,360	13,475,350	11,786,410	16,140,190	12,572,121
Other E. Indian . .	1,327,720	3,872,450	1,242,000	2,441,190	5,331,190	5,331,150	8,757,552	4,707,640
Japan, . . . . .	32,547,509	46,007,530	26,824,694	42,787,890	43,810,870	60,540,424	67,707,658	58,067,925
Other Asiatic, . . .	849,415	918,574	4,194,710	11,923,490	8,775,675	7,973,490	5,610,450	11,596,113
<b>Total, . . . . .</b>	<b>90,359,174</b>	<b>134,313,296</b>	<b>174,941,348</b>	<b>164,893,450</b>	<b>196,303,228</b>	<b>239,650,348</b>	<b>238,541,800</b>	<b>202,999,639</b>
<b>Oceania—</b>								
British Australasia	22,953,588	18,212,764	21,633,821	20,618,140	21,621,640	22,129,092	26,776,434	26,341,385
Hawaiian Islands, .								
Philippine Islands .	2,803,101	3,294,020	7,558,810	1,641,178	6,141,490	10,097,393	8,997,610	6,265,167
Other Oceanian, . .	12,435	11,056	4,770	1,370	4,410	1,285	1,070	121,520
<b>Total, .. . . .</b>	<b>25,769,124</b>	<b>21,517,840</b>	<b>28,997,401</b>	<b>22,260,688</b>	<b>27,767,540</b>	<b>32,227,770</b>	<b>35,775,114</b>	<b>32,728,072</b>
<b>Africa—</b>								
British Africa . . .	12,287,696	10,609,429	11,621,470	13,477,323	9,976,024	10,966,114	8,484,285	18,135,570
Other Africa, . . .	1,997,448	3,186,435	3,990,181	14,803,313	12,070,862	7,451,905	7,778,563	12,522,003
<b>Total, . . . . .</b>	<b>14,285,144</b>	<b>13,795,864</b>	<b>15,611,651</b>	<b>28,280,636</b>	<b>22,046,886</b>	<b>18,418,019</b>	<b>16,262,848</b>	<b>30,657,573</b>
<b>Total Illuminating,</b>	<b>699,807,201</b>	<b>741,567,086</b>	<b>822,881,953</b>	<b>864,361,210</b>	<b>894,529,432</b>	<b>1,041,725,901</b>	<b>1,080,542,456</b>	<b>1,005,027,536</b>
<b>Lubricating Oil,</b>								
<b>Europe—</b>								
Belgium, . . . . .	5,431,086	4,473,379	6,212,754	12,719,017	10,582,303	9,706,311	9,853,648	10,671,107
France, . . . . .	8,622,352	6,793,879	8,755,856	19,007,626	15,241,696	19,943,853	18,581,934	20,658,620
Germany, . . . . .	11,670,529	11,421,404	12,385,112	19,229,818	19,591,795	22,158,084	19,708,146	20,533,022
Italy, . . . . .	2,925,126	2,961,857	3,528,671	4,974,497	6,139,766	5,846,997	7,656,884	7,606,839
Netherlands, . . . .	6,161,447	5,424,718	6,569,410	9,485,260	8,808,058	9,650,719	8,372,364	9,571,203
United Kingdom, . .	34,854,074	33,890,901	35,671,115	46,245,278	42,141,248	50,427,085	42,000,598	54,748,608
Other countries, . . .	2,740,415	2,804,739	3,514,778	5,736,974	5,648,556	6,936,297	6,868,299	7,986,759
<b>Total, . . . . .</b>	<b>72,405,029</b>	<b>67,830,877</b>	<b>76,537,696</b>	<b>117,398,470</b>	<b>108,153,422</b>	<b>124,668,346</b>	<b>113,041,873</b>	<b>131,771,158</b>
<b>North America, . . .</b>	<b>2,606,388</b>	<b>2,709,577</b>	<b>2,603,403</b>	<b>3,244,991</b>	<b>4,344,331</b>	<b>4,287,590</b>	<b>4,537,812</b>	<b>6,095,575</b>
West Indies, . . . .	616,721	820,913	786,106	941,191	1,753,262	1,240,239	1,278,500	1,380,979
South America, . . .	3,115,266	3,470,324	3,621,853	4,840,251	5,402,478	6,057,608	6,742,209	7,494,903
Asia and Oceania, . .	12,569,338	11,864,610	11,798,775	16,622,725	14,340,665	20,203,987	15,583,310	17,047,643
Africa, . . . . .	2,005,515	2,103,829	2,009,363	3,063,074	2,145,568	3,306,130	3,070,567	6,640,019
<b>Total, . . . . .</b>	<b>20,913,228</b>	<b>20,979,253</b>	<b>20,819,500</b>	<b>28,712,232</b>	<b>27,986,804</b>	<b>35,095,554</b>	<b>31,212,398</b>	<b>38,659,119</b>
<b>Total Lubricating,</b>	<b>93,318,257</b>	<b>88,810,130</b>	<b>97,357,196</b>	<b>146,110,702</b>	<b>136,140,226</b>	<b>159,763,900</b>	<b>144,254,271</b>	<b>170,430,277</b>
<b>RESIDUUM (Barrels)</b>								
Europe, . . . . .	532,880	511,779	1,101,804	1,688,741	63,650,768	65,979,758	92,070,389	112,792,362
North America, . . .	9,654	24,131	59,768	95,451	1,323,710	4,467,937	10,962,529	10,742,492
All other countries, . .	359	1,245	3,889	2,280	253,531	134,127	155,115	520,409
<b>Total Residuam,</b>	<b>542,893</b>	<b>537,155</b>	<b>1,165,461</b>	<b>1,786,472</b>	<b>65,228,009</b>	<b>70,581,822</b>	<b>103,188,033</b>	<b>124,055,263</b>

Note.—The quantities given under "other countries" may include the amount exported to the countries specified in the table against which, in any one year, no figures are given.

## EXPORTS OF CRUDE PETROLEUM AND PETROLEUM PRODUCTS—continued.

COUNTRIES.	1911.	1912.	1913.	1914.	1915.	1916.	1917.	1918.
<b>South America—</b>								
Argentina, . . .	15,723,182	28,449,374	21,367,616	13,601,695	15,408,268	12,587,302	13,064,881	7,739,534
Brazil, . . .	30,846,695	37,491,101	32,828,176	27,360,874	34,734,254	30,756,971	30,817,597	12,406,067
Chile, . . .	7,123,137	7,361,898	7,961,224	7,809,919	5,093,957	6,465,611	6,757,639	5,640,956
Uruguay, . . .	6,140,675	6,675,489	8,561,419	..	..	..	..	..
Venezuela, . . .	1,449,897	1,511,255	1,552,294	..	..	..	..	..
Other countries, . . .	3,270,171	2,961,441	2,790,195	9,923,599	11,970,999	11,585,498	9,184,554	5,762,376
Total, . . .	64,553,757	84,450,558	75,060,924	58,696,877	67,207,478	61,195,382	59,824,671	31,548,933
<b>Asia—</b>								
China, . . .	107,167,449	68,164,997	79,015,610	91,430,759	84,866,476	85,689,334	68,949,092	43,458,543
British India, . . .	12,074,776	14,794,710	7,767,090	28,557,294	31,142,291	49,802,870	29,485,437	8,170,457
Hong Kong, . . .	..	..	..	26,586,208	14,467,706	21,674,231	14,090,907	8,479,016
<b>East Indies—</b>								
British, . . .	51,735,360	57,390,564	36,171,967	..	..	..	..	..
Dutch, . . .	19,235,260	14,370,190	13,417,693	12,886,767	11,269,844	11,342,660	11,702,690	2,365,000
Other E. Indian, . . .	6,185,050	7,246,805	4,700,340	..	..	..	..	..
Japan, . . .	57,750,354	109,215,587	85,399,913	107,818,222	61,208,219	44,223,949	20,488,540	16,219,296
Other Asiatic, . . .	19,887,195	15,101,190	22,891,700	..	..	..	..	..
Total, . . .	274,035,444	286,284,043	249,364,313	267,279,250	202,954,536	212,733,044	144,716,666	78,692,312
<b>Oceania—</b>								
British Oceania, . . .	29,478,944	32,077,747	25,635,287	29,097,258	36,797,957	27,587,720	19,990,057	18,328,887
Philippine Islands, . . .	9,887,437	14,054,707	13,073,752	12,906,403	8,524,833	8,539,700	6,252,140	6,495,910
Other Oceanian, . . .	17,084	18,417	44,904	..	..	..	..	..
Total, . . .	39,383,465	46,150,871	38,753,943	42,003,661	45,322,790	36,127,420	26,242,197	24,824,797
<b>Africa—</b>								
British Africa, . . .	16,604,729	14,961,057	14,449,160	15,311,124	14,831,586	17,657,838	7,146,088	10,761,375
Other Africa, . . .	36,025,605	16,532,125	11,972,103	..	..	..	..	..
Total, . . .	52,630,334	31,493,182	26,421,263	15,311,124	14,831,586	17,657,838	7,146,088	10,761,375
Other countries, . . .	..	..	..	57,942,409	62,305,925	52,678,107	43,696,132	20,671,039
Total Illuminating, . . .	1,022,311,042	1,044,049,848	1,048,894,297	1,010,449,253	836,958,665	854,688,404	658,156,487	491,109,815
<i>Lubricating Oil.</i>								
<b>Europe—</b>								
Belgium, . . .	10,229,815	11,806,155	13,782,639	8,925,907	..	..	..	..
France, . . .	19,449,734	25,575,537	26,136,545	20,637,262	38,744,744	56,539,190	71,687,467	43,886,076
Germany, . . .	20,450,031	24,308,176	26,418,269	10,733,165	..	..	..	..
Italy, . . .	8,323,598	9,283,969	7,637,394	10,745,072	23,200,173	17,019,194	20,067,146	17,137,330
Netherlands, . . .	10,488,285	11,596,618	12,174,926	14,219,051	6,469,414	3,596,943	534,296	7,500
United Kingdom, . . .	53,573,129	62,886,561	61,412,394	63,411,439	87,672,667	95,951,712	111,647,001	114,043,663
Other countries, . . .	9,026,568	11,189,030	13,243,346	13,443,281	29,028,538	18,837,245	9,117,264	7,419,966
Total, . . .	131,541,160	156,446,046	160,805,513	142,115,177	185,115,536	191,944,284	213,053,174	182,494,535
<b>North America—</b>								
Canada, . . .	..	..	..	6,348,537	5,715,496	5,560,526	7,745,713	7,009,174
Mexico, . . .	..	..	..	694,436	745,739	619,608	644,201	894,576
Cuba, . . .	..	..	..	1,566,116	1,888,835	2,357,169	3,352,880	3,320,172
Total, . . .	6,095,575	7,587,478	9,846,385	8,609,089	8,350,070	9,037,303	11,742,794	11,223,922
West Indies, . . .	1,505,270	1,717,456	1,881,707	..	..	..	..	..
<b>South America—</b>								
Argentina, . . .	..	..	..	3,093,143	5,073,168	6,086,546	5,770,002	5,477,823
Brazil, . . .	..	..	..	2,767,220	3,898,928	3,674,350	4,833,617	3,326,766
Chile, . . .	..	..	..	1,533,375	2,037,617	2,696,410	2,556,557	3,847,413
Total, . . .	7,843,115	10,162,069	11,504,006	7,393,738	11,003,713	12,457,306	13,160,176	12,652,002
<b>Asia and Oceania, . . .</b>								
Japan, . . .	..	..	..	3,149,380	3,198,906	3,358,197	4,264,920	8,348,113
<b>Oceania—</b>								
British East Indies, . . .	..	..	..	10,818,024	11,901,180	16,498,674	13,308,716	12,483,183
British Oceania, . . .	..	..	..	6,863,340	6,364,060	9,410,414	6,725,247	12,075,669
Total, . . .	..	..	..	17,681,364	18,265,240	25,909,088	24,298,883	32,906,965
Africa, . . .	6,936,056	5,352,277	6,385,866	..	..	..	..	..
British Africa, . . .	..	..	..	2,060,604	2,634,415	4,142,524	4,360,474	3,943,573
Other countries, . . .	..	..	..	10,638,218	11,104,845	13,957,237	13,822,262	14,096,256
Total Lubricating, . . .	178,642,495	202,125,197	213,671,499	191,647,570	239,678,725	260,805,939	280,437,763	257,317,253
<i>Gas and Fuel Oil.</i>								
<b>Europe, . . .</b>								
North America, . . .	..	..	152,327,387	..	..	..	..	..
South America, . . .	..	..	100,101,349	..	..	..	..	..
Asia, . . .	..	..	66,883,200	..	..	..	..	..
Oceania, . . .	..	..	..	..	..	..	..	..
Africa, . . .	..	..	38,213	..	..	..	..	..
Total Gas and Fuel Oil, . . .	..	..	320,529,925	634,298,844	799,589,047	957,602,359	1,123,473,047	1,200,750,319
<b>RESIDUUM.</b>								
Europe, . . .	102,430,883	111,321,764	146,037	..	..	..	..	..
North America, . . .	15,708,381	30,443,892	2,169,607	..	..	..	..	..
All other countries, . . .	5,258,924	26,579,822	25,197,924	..	..	..	..	..
Total Residuam, . . .	123,398,188	168,339,478	27,513,668	69,209,777	12,627,162	6,487,578	1,051,113	244,474

CONSUMPTION OF FUEL OIL BY THE RAILROADS OF THE UNITED STATES, 1907 TO 1918.

Year.	Quantity consumed in Barrels of 42 U.S.A. Gallons.	Length of line in Miles operated by the use of Fuel Oil. <i>a</i>	Estimated Mileage covered by Oil-burning Engines.	Average Miles per Barrel of Oil consumed.
1907, . . .	18,849,803	13,573	74,079,726	3-93
1908, . . .	16,870,882	15,474	64,279,509	3-81
1909, . . .	19,905,335	17,676	72,918,118	3-66
1910, . . .	23,817,346	22,709	89,107,883	3-74
1911, . . .	29,748,845	30,039	109,680,976	3-69
1912, . . .	33,605,598	28,451	121,393,228	3-61
1913, . . .	33,004,815	29,145	118,672,162	3-60
1914, . . .	31,093,266	29,595	118,737,469	3-82
1915, . . .	32,830,187	30,776	124,255,525	3-78
1916, . . .	38,208,516	31,980	140,434,566	3-68
1917, . . .	42,238,565	33,109	148,825,340	3-52
1918, . . .	36,713,667	35,211	128,528,039	3-50

*a* Some of these lines also used coal.

RUSSIA.

PRODUCTION OF CRUDE OIL IN THE BAKU FIELD.

Field.	Poods.							
	1905.	1906.	1907.	1908.	1909.	1910.	1911.	1912.
Balakhani, . . .	..	67,900,000	71,300,000	70,300,000	72,900,000	68,400,000	63,800,000	65,300,000
Sabuntchi, . . .	..	157,000,000	184,000,000	198,800,000	207,000,000	195,000,000	176,000,000	170,400,000
Romani, . . .	..	95,400,000	89,600,000	78,300,000	87,600,000	96,100,000	83,100,000	78,800,000
Bibi-Eibat, . . .	..	127,700,000	131,300,000	119,600,000	122,800,000	118,700,000	102,500,000	104,600,000
Surakhani, . . .	..	..	..	..	2,000,000	10,700,000	19,900,000	32,200,000
Total, . . .	414,762,000	448,000,000	476,200,000	467,000,000	492,300,000	488,900,000	445,300,000	451,300,000

Field.	1913.	1914.	1915.	1916.	1917.	1918.	1919.
Balakhani, . . .	65,700,000	67,000,000	66,800,000	329,856,947	50,546,161	25,526,556	30,871,863
Sabuntchi, . . .	160,300,000	143,800,000	143,100,000		103,087,400	43,992,327	57,244,465
Romani, . . .	70,500,000	53,700,000	53,700,000		48,042,598	22,416,181	36,667,676
Bibi-Eibat, . . .	93,300,000	72,100,000	79,200,000		60,914,101	29,268,928	37,359,198
Surakhani, . . .	40,200,000	51,900,000	60,600,000		96,597,365	96,251,825	48,328,950
Total, . . .	430,000,000	388,500,000	403,400,000	426,454,312	358,842,085	170,554,323	210,472,152

PRODUCTION OF CRUDE PETROLEUM IN RUSSIA.

Year.	Quantity. Poods.	Year.	Quantity. Poods.
1905, . . .	. . . 457,819,052	1912, . . .	. . . 566,600,000
1906, . . .	. . . <i>a</i> 490,614,603	1913, . . .	. . . 523,410,191
1907, . . .	. . . 515,216,612	1914, . . .	. . . 558,280,944
1908, . . .	. . . <i>b</i> 518,013,116	1915, . . .	. . . 571,005,357
1909, . . .	. . . 549,533,015	1916, . . .	. . . <i>d</i> 606,433,246
1910, . . .	. . . <i>c</i> 585,903,660	1917, . . .	. . . <i>e</i> 583,000,000
1911, . . .	. . . 551,310,151	1918, . . .	. . . <i>e</i> 337,000,000

*a* Includes 4,721,000 poods produced in Bereki and Tchimion oil-fields.

*b* Includes 611,221 poods produced in Surakhani.

*c* Includes 10,613,909 poods produced in Surakhani, 1,392,306 poods produced in Sviatoi, 610,500 poods produced in Ferghana, and 91,575 poods produced in Taman.

*d* Estimated in part.

*e* Estimated.

## CONDITION OF WELLS IN BAKU FIELD.

NUMBER AND CONDITION OF THE WELLS IN THE BAKU FIELD FOR THE YEARS ENDED DECEMBER 31ST, 1915, AND AUGUST 31ST, 1916.<sup>a</sup>

Condition of Wells.	Balakhani.		Sabuntchi.		Romani.		Bibi-Eibat.		Total.	
	1915.	1916.	1915.	1916.	1915.	1916.	1915.	1916.	1915.	1916.
	Completed, . . . . .	42	..	59	..	20	..	17	..	138
Producing, . . . . .	1,055	1,063	1,339	1,314	284	285	297	316	2,975	2,978
Trial pumping, . . . . .	6	3	6	7	4	3	3	2	19	15
Being drilled, . . . . .	55	37	68	75	65	60	43	58	231	230
Being drilled deeper, . . . . .	19	37	29	68	8	45	19	42	75	192
Cleaning out and repairing, . . . . .	42	2	75	12	52	18	50	6	219	38
Standing idle, . . . . .	418	477	867	968	310	338	253	253	1,848	2,036
Rigs up, ready for drilling, . . . . .	58	63	63	59	14	13	14	11	149	146
New wells sunk during year, . . . . .	38	..	65	..	42	..	14	..	159	..
Length of wells drilled, in feet, . . . . .	76,090	3,603	122,458	9,807	81,410	5,140	53,711	3,204	333,669	21,754

<sup>a</sup> Complete details for 1916 are not available.

PRODUCTION OF CRUDE OIL BY FOUNTAINS IN THE GROZNI FIELD.

1899, . . . . .	8,094,822	poods.	1909, . . . . .	6,035,564	poods.
1900, . . . . .	6,685,117	"	1910, . . . . .	15,950,625	"
1901, . . . . .	8,086,681	"	1911, . . . . .	3,708,086	"
1902, . . . . .	16,025,478	"	1912, . . . . .	109,920	"
1903, . . . . .	10,718,761	"	1913, . . . . .	5,015,760	"
1906, . . . . .	8,331,691	"	1914, . . . . .	12,671,740	"
1907, . . . . .	5,373,850	"	1915, . . . . .	1,781,062	"
1908, . . . . .	14,316,915	"			

PRODUCTION OF CRUDE OIL IN THE GROZNI FIELD.

Year.	Poods.	Year.	Poods.	Year.	Poods.
1896	17,200,151	1904	39,797,000	1912	65,400,000
1897	27,568,794	1905	41,328,000	1913	73,659,265
1898	17,716,899	1906	38,373,603	1914	98,445,187
1899	25,194,566	1907	39,214,612	1915	88,159,052
1900	30,687,948	1908	52,058,895	1916	a 102,731,246
1901	34,852,271	1909	57,033,015	1917	b 123,000,000
1902	34,072,271	1910	74,048,358	1918	b 110,000,000
1903	32,772,271	1911	75,189,591		

a Estimated in part.

b Estimated.

PARTICULARS OF THE WELLS IN THE GROZNI FIELD.

Year.	Total number of Wells.	Producing Dec. 31.	Boring and deepening Dec. 31.	Average depth of Wells in feet.	Total sum of depth, in feet, of producing Wells.	Total length, in feet, of Wells drilled in the year.
1907	271	205	45	..	185,346	..
1908	287	172	51	1348.2	203,574	..
1909	320	182	58	1458.1	250,831	82,537
1910	343	234	67	1557.0	..	87,836
1911	358	195	61	1670.0	..	72,933
1912	402	264	71	1752.0	..	119,165
1913	554	352	116	1798.0	..	201,867
1914	665	435	123	1885.0	..	275,814
1915	..	..	..	..	..	178,143
1916	..	..	..	..	..	151,732

AUSTRIA.

PRODUCTION OF CRUDE PETROLEUM IN GALICIA FROM 1886 TO 1918.

Year.	Production (in Metre Centners).	Year.	Production (in Metre Centners).
1886, . . . . .	425,387	1903 . . . . .	7,279,710
1887, . . . . .	478,176	1904, . . . . .	8,271,167
1888, . . . . .	648,824	1905, . . . . .	8,017,964
1889, . . . . .	716,595	1906, . . . . .	7,604,432
1890, . . . . .	916,504	1907, . . . . .	11,759,740
1891, . . . . .	877,174	1908, . . . . .	17,540,220
1892, . . . . .	898,713	1909, . . . . .	20,767,400
1893, . . . . .	963,312	1910, . . . . .	17,625,600
1894, . . . . .	1,320,000	1911, . . . . .	14,629,400
1895, . . . . .	2,148,100	1912, . . . . .	11,870,070
1896, . . . . .	3,397,650	1913, . . . . .	10,872,860
1897, . . . . .	3,096,263	1914, . . . . .	a 7,000,000
1898, . . . . .	3,231,420	1915, . . . . .	5,783,880
1899, . . . . .	3,216,810	1916, . . . . .	8,986,700
1900, . . . . .	3,263,340	1917, . . . . .	8,296,290
1901, . . . . .	4,522,000	1918, . . . . .	7,776,400
1902, . . . . .	5,760,600		

a Estimated.

## GALICIAN PRODUCTION IN 1917 AND 1918.

Locality.	1917.	1918.
	Metric Tons.	Metric Tons.
Western Galicia :—		
Potok, . . . . .	} a 120,000	} a 100,000
Rogi, . . . . .		
Rowne, . . . . .		
Krosno, . . . . .		
Tarnaawa-Wielopole-Zagorz,		
Kobylanka, Kryg, Zalawie, Lipinki, Libusza, and other localities, . . . . .		
Eastern Galicia :—		
Tustanowice, . . . . .	403,212	321,750
Boryslaw, . . . . .	247,926	297,400
Schodnica, . . . . .	..	..
Urycz, . . . . .	..	..
Mraznica, . . . . .	51,929	58,490
Other localities, . . . . .	6,562	..
Total, . . . . .	829,629	777,640

a Estimated.

IMPORTS AND EXPORTS OF PETROLEUM INTO AND FROM AUSTRIA-HUNGARY  
IN METRIC TONS.

	1907.		1908.		1909.	
	Imports.	Exports.	Imports.	Exports.	Imports.	Exports.
Illuminating oils, . . . . .	2,717	141,572	1,868	234,160	1,761	290,915
Lubricating and other oils, . . . . .	16,079	63,250	16,268	111,060	19,614	130,862
Benzine, . . . . .	8	12,637	8	25,597	10	32,528
Paraffin, . . . . .	313	14,737	357	28,666	507	38,042
Crude petroleum, . . . . .	18,342	8,250	3,114	6,250	..	51,558
Ozokerite, . . . . .	..	..	..	..	..	..
Ceresin, . . . . .	..	..	..	..	..	..
Total, . . . . .	37,459	240,446	21,615	405,733	21,892	543,905

	1910.		1911.		1912.		1913.	
	Imports.	Exports.	Imports.	Exports.	Imports.	Exports.	Imports.	Exports.
Illuminating oils, . . . . .	1,460	266,739	1,517	265,378	1,377	383,183	1,868	285,445
Lubricating and other oils, . . . . .	15,358	139,071	18,213	91,065	19,687	155,583	27,037	155,907
Benzine, . . . . .	40	39,320	10	41,904	89	68,698	2,683	49,773
Paraffin, . . . . .	455	44,432	631	37,940	546	51,594	300	43,101
Crude petroleum, . . . . .	18,967	5,472	19,020	610	17,873	1,660	19,134	1,112
Ozokerite, . . . . .	..	..	..	..	150	2,525	146	2,275
Ceresin, . . . . .	..	..	..	..	39	1,712	16	1,550
Total, . . . . .	36,280	495,034	39,391	436,897	39,761	664,955	51,184	539,163

DELIVERIES, IN METRIC TONS, OF GALICIAN PETROLEUM TO REFINERIES, 1907 TO 1910.

	1907.	1908.	1909.	1910.
Delivered to Refineries—				
In Galicia and Bukowina, . . . . .	281,344	457,020	451,290	362,160
In the rest of Austria, . . . . .	422,829	540,820	672,970	547,950
In Hungary, . . . . .	272,995	338,720	384,090	319,380
To the state refinery in Drohobycz, . . . . .	..	..	..	208,760
<b>Total, . . . . .</b>	<b>977,168</b>	<b>1,336,560</b>	<b>1,508,350</b>	<b>1,438,250</b>
Exported, . . . . .	..	..	41,920	3,280
Used as fuel, . . . . .	..	..	120,000	97,430
Left in store, . . . . .	..	..	406,470	..
Delivered to state installation at Kolpen and Modryczu, . . . . .	..	..	..	819,700
<b>Total, . . . . .</b>	<b>..</b>	<b>..</b>	<b>2,076,740</b>	<b>2,358,660</b>

## BUKOWINA.

No statistics relating to the small yield of crude petroleum in the Bukowina appear to be available.

## EASTERN ARCHIPELAGO.

According to the "Mineral Resources of the United States," the production of petroleum in Sumatra, Java, and Borneo up to 1918 was as follows:—

Year.	Sumatra.	Java.	Borneo.	Total.
	Metric Tons.	Metric Tons.	Metric Tons.	Metric Tons.
1900, . . . . .	<i>a</i> 158,467	83,867	59,352	301,686
1901, . . . . .	<i>a</i> 357,665	88,597	85,554	531,816
1902, . . . . .	186,655	54,455	84,232	325,342
1903, . . . . .	563,988	91,568	105,102	760,658
1904, . . . . .	542,936	110,053	215,109	868,098
1905, . . . . .	513,630	110,711	439,487	1,063,828
1906, . . . . .	602,501	111,378	387,455	1,101,334
1907, . . . . .	713,841	142,983	489,151	1,345,975
1908, . . . . .	738,588	137,013	511,049	1,386,650
1909, . . . . .	922,894	140,351	411,506	1,474,751
1910, . . . . .	719,740	142,503	633,472	1,495,715
1911, . . . . .	683,523	172,438	814,707	1,670,668
1912, . . . . .	621,481	184,989	671,662	1,478,132
1913, . . . . .	529,947	207,135	797,059	<i>b</i> 1,534,223
1914, . . . . .	475,423	226,590	<i>d</i> 931,903	<i>c</i> 1,634,403
1915, . . . . .	491,611	256,838	<i>e</i> 960,896	<i>f</i> 1,710,445
1916, . . . . .	526,080	243,442	<i>g</i> 1,047,462	<i>h</i> 1,820,247
1917, . . . . .	583,384	246,126	<i>i</i> 946,737	<i>j</i> 1,778,495
1918, . . . . .	519,989	241,212	<i>k</i> 1,072,140	<i>l</i> 1,836,914

*a* Estimated.

*b* Includes 82 metric tons produced in Ceram.

*c* Includes 487 metric tons produced in Ceram.

*d* Includes 65,185 metric tons produced in British Borneo.

*e* Includes 67,000 metric tons produced in British Borneo.

*f* Includes 1100 metric tons produced in Ceram.

*g* Includes 90,067 metric tons produced in British Borneo.

*h* Includes 2363 metric tons produced in Ceram.

*i* Includes 77,614 metric tons produced in British Borneo.

*j* Includes 2248 metric tons produced in Ceram.

*k* Includes 72,714 metric tons produced in British Borneo.

*l* Includes 3574 metric tons produced in Ceram.

## RUMANIA.

The following figures, extracted from the report of the Rumanian Minister of Agriculture and Commerce, give the production of crude oil in Rumania from 1890 to 1919:—

Year.	Quantity in Metric Tons.	Year.	Quantity in Metric Tons.	Year.	Quantity in Metric Tons.	Year.	Quantity in Metric Tons.
1890	41,670	1898	140,700	1906	887,091	1913	1,885,225
1891	50,690	1899	182,540	1907	1,129,097	1914	1,783,947
1892	56,170	1900	224,760	1908	1,147,727	1915	1,673,145
1893	56,600	1901	233,100	1909	1,296,403	1916	a1,244,093
1894	64,530	1902	286,500	1910	1,352,407	1917	b517,491
1895	76,660	1903	384,302	1911	1,544,847	1918	b1,214,219
1896	77,720	1904	500,561	1912	1,804,761	1919	921,847
1897	88,270	1905	614,880				

a Up to time of evacuation by Rumania.

b Estimated.

## STATISTICS OF RUMANIAN PETROLEUM INDUSTRY.

(Quantities given in Metric Tons.)

	1905.	1906.	1907.	1908.	1909.	1910.
Crude oil production, . . . . .	614,870	887,091	1,129,097	1,147,727	1,297,257	1,352,407
Crude oil treated at refineries, . .	510,143	748,798	950,614	1,012,616	1,107,825	1,215,299
Output of refineries—						
Benzine, . . . . .	78,182	114,428	146,263	180,190	201,253	230,703
Illuminating oil, . . . . .	153,499	221,683	261,684	248,274	263,998	272,222
Lubricating oil, . . . . .	17,255	53,588	57,337	89,753	43,446	25,064
Residuals, . . . . .	237,677	333,714	452,685	473,770	576,600	667,260
Home consumption—						
Benzine, . . . . .	2,696	4,059	5,689	9,055	14,041	20,314
Illuminating oil, . . . . .	31,558	35,243	38,467	38,422	39,451	41,849
Lubricating oil, . . . . .	6,307	9,848	9,047	11,955	15,698	17,544
Residuals, . . . . .	162,243	237,477	332,999	347,323	366,703	360,551
Fuel at the refineries, . . . . .	..	..	..	113,753	109,077	108,314
Exports—						
Benzine, . . . . .	46,696	71,114	89,522	122,860	108,218	125,751
Illuminating oil and distillate, . .	118,134	196,631	262,489	263,633	261,637	339,282
Crude, residuals, etc., . . . . .	49,515	53,374	78,423	78,765	49,715	116,223
Paraffin, . . . . .	..	..	151	187	545	285
Stocks on December 31st—						
Benzine, . . . . .	20,084	18,275	47,506	44,783	40,071	29,006
Illuminating oil, . . . . .	30,144	48,967	36,128	41,541	79,613	56,557
Lubricating oil and residuals, . .	64,452	67,334	67,816	73,761	157,204	270,493
	1911.	1912.	1913.	1914.	1915.	1916a.
Crude oil production, . . . . .	1,544,847	1,804,761	1,885,225	1,783,947	1,673,145	658,107
Crude oil treated at refineries, . .	1,404,403	1,667,389	1,787,245	1,680,894	1,580,981	695,452
Output of refineries—						
Benzine, . . . . .	260,653	352,492	422,019	396,865	394,809	164,536
Illuminating oil, . . . . .	312,711	345,802	380,074	352,682	263,633	125,164
Lubricating oil, . . . . .	24,703	43,438	48,416	100,047	129,685	78,506
Residuals, . . . . .	783,136	898,011	906,735	807,276	765,676	313,617
Home consumption—						
Benzine, . . . . .	24,450	30,656	30,131	31,672	31,762	12,013
Illuminating oil, . . . . .	43,941	49,941	51,396	51,710	52,741	19,010
Lubricating oil, . . . . .	22,401	28,997	33,725	40,816	48,348	22,510
Paraffin, . . . . .	..	1,138	1,425	1,416	1,849	925
Residuals, . . . . .	434,094	540,385	560,492	524,254	501,943	262,365
Fuel at the refineries, . . . . .	123,029	140,690	135,728	134,324	166,189	..
Exports—						
Benzine, . . . . .	124,384	173,817	237,168	164,143	13,132	..
Illuminating oil and distillate, . .	318,441	353,563	418,622	297,800	272,899	100,897
Crude, residuals, etc., . . . . .	233,895	318,443	380,077	191,545	142,816	177,047
Paraffin, . . . . .	476	600	579	536	243	..
Stocks on December 31st—						
Crude (pipe-line and refinery), . .	..	..	..	5200,000	5250,000	..
Benzine, . . . . .	51,862	60,647	66,746	..	..	..
Illuminating oil, . . . . .	73,908	126,009	145,446	5500,000	6800,000	..
Lubricating oil and residuals, . .	248,375	227,140	79,766	..	..	..

a For five months ended May 31st.

b Approximate.



The yield of crude petroleum in the various oil-fields was as follows :—

OUTPUT OF CRUDE OIL IN THE RUMANIAN OIL-FIELDS  
FROM 1900 TO 1905, IN METRIC TONS.

Locality.	1900.	1901.	1902.	1903.	1904.	1905.
<b>PRAHOVA—</b>						
Bustenari, . . . . .	..	..	..	233,111	331,860	411,407
Campina-Poiana, . . . . .	..	..	..	101,106	109,269	94,860
Moreni, . . . . .	..	..	..	..	4,349	47,243
Baicoi, . . . . .	..	..	..	3,320	2,145	1,949
Tintea, . . . . .	..	..	..	6,145	4,100	7,412
Pacuretzî-Ochisori, . . . . .	..	..	..	..	678	989
Apostolache, . . . . .	..	..	..	122	179	415
Podeni-Noui, . . . . .	..	..	..	55	493	498
Bordeni-Parsani, . . . . .	..	..	..	692	442	307
Provitza de Jos, . . . . .	..	..	..	..	118	218
Vulcanesti, . . . . .	..	..	..	..	115	100
Recea, . . . . .	..	..	..	1,162	1,584	2,690
Oparitzl-Copaceni, . . . . .	..	..	..	..	..	180
Chioideanca, . . . . .	..	..	..	..	..	21
Poiana-Verbileu, . . . . .	..	..	..	200	22	..
Gornetu, Cuibu . . . . .	..	..	..	..	..	4
Total, . . . . .	149,500	190,900	236,000	345,913	455,354	568,293
<b>DAMBOVITZA—</b>						
Gura Ocnitei, . . . . .	..	..	..	16,459	19,619	17,294
Colibasi, . . . . .	..	..	..	5,900	4,752	4,216
Resca, . . . . .	..	..	..	88	89	104
Maluri-Rosu, . . . . .	..	..	..	22	94	134
Glodeni-Badislavoaia, . . . . .	..	..	..	..	1,680	2,955
Total, . . . . .	28,000	25,620	29,000	22,469	26,234	24,703
<b>BUZEU—</b>						
Sarata, . . . . .	..	..	..	5,542	7,975	12,254
Berca, . . . . .	..	..	..	328	853	602
Tega, . . . . .	..	..	..	50	..	13
Policiori, . . . . .	..	..	..	..	..	35
Total, . . . . .	24,000	3,330	6,500	5,920	8,828	12,904
<b>BACAU—</b>						
Total, . . . . .	25,000	13,250	15,000	10,000	10,145	8,974
Total, . . . . .	226,500	233,100	286,500	384,302	500,561	614,874

PRODUCTION OF PETROLEUM IN RUMANIA IN METRIC TONS.

District.	1906.	1907.	1908.	1909.	1910.
<b>Prahova—</b>					
Bustenari, . . . . .	509,995	479,454	473,106	393,242	318,269
Campina-Poiana, . . . . .	102,148	230,134	233,825	311,147	333,382
Moreni, . . . . .	162,806	292,147	337,763	369,784	438,475
Other, . . . . .	71,240	75,936	51,127	147,469	155,177
Dambovitza, . . . . .	20,142	32,314	26,272	30,288	43,295
Buzeu, . . . . .	11,680	9,927	10,768	25,389	39,717
Bacau, . . . . .	9,080	9,185	14,866	19,084	23,974
Total, . . . . .	887,091	1,129,097	1,147,727	1,296,403	1,352,289

PRODUCTION OF PETROLEUM IN RUMANIA IN METRIC TONS (*continued*).

District.	1911.	1912.	1913.	1914.	1915.	1916. <i>a</i>	1917. <i>b</i>	1918. <i>b</i>
Prahova—								
Bustenari, .	311,959	301,631	303,614	293,987	286,035	236,950	52,000	166,936
Campina- Poiana, .	313,034	295,405	243,715	174,513	120,657	80,000	77,905	97,496
Moreni, .	585,254	878,101	981,953	896,096	741,163	530,000	224,350	494,650
Other, .	174,315	139,564	148,477	171,931	283,437	203,073	65,221	191,090
Dambovitza,	69,077	74,316	41,583	49,168	100,824	72,670	27,376	161,299
Buzeu, .	62,980	87,271	125,722	148,415	112,098	96,400	14,639	60,543
Bacau, .	27,453	28,473	40,161	49,837	28,931	25,000	56,000	42,205
Total, .	1,544,072	1,804,761	1,885,225	1,783,947	1,673,145	1,244,093	517,491	1,214,219

*a* Up to time of evacuation by Rumania.*b* Estimated.

## CONDITION OF THE WELLS IN RUMANIA IN 1916.

1st January 1916.

District.	Drilled Wells.			Hand-dug Shafts.		
	Producing.	Drilling.	Abandoned.	Producing.	Sinking.	Abandoned.
Prahova, . . .	805	294	548	93	235	312
Dambovitza, . .	85	30	41	44	1	47
Buzeu, . . .	21	27	14	56	21	144
Bacau, . . .	65	11	40	360	22	462
Total, . . .	976	362	643	553	279	965

31st July 1916.

Prahova, . . .	856	273	546	99	206	294
Dambovitza, . .	23	27	16	58	14	141
Buzeu, . . .	93	40	46	44	3	47
Bacau, . . .	71	10	50	360	22	462
Total, . . .	1,043	350	658	561	245	944

BRITISH INDIA.

PRODUCTION AND VALUE OF CRUDE PETROLEUM IN BRITISH INDIA.

Year.	Assam.			Baluchistan.			Burma.			Punjab.			Total.		
	Quantity, Imperial Gallons.	Value, £.	Quantity, Imperial Gallons.	Value, £.	Quantity, Imperial Gallons.	Value, £.	Quantity, Imperial Gallons.	Value, £.	Quantity, Imperial Gallons.	Value, £.	Quantity, Imperial Gallons.	Value, £.	Quantity, Imperial Gallons.	Value, £.	
1891	..	..	40,465	233	6,611,914	23,906	2,191	47	6,654,570	24,186					
1892	..	..	2,950	17	8,474,787	24,193	2,206	32	8,479,943	24,942					
1893	..	..	..	625	10,461,646	51,378	2,262	29	10,463,908	51,407					
1894	166,904	2,225	50,000	..	11,234,002	72,239	1,743	27	11,439,649	75,116					
1895	36,435	486	..	..	12,965,753	102,106	1,560	23	13,003,748	102,610					
1896	923,890	1,459	..	..	14,808,190	117,663	2,364	22	15,074,449	119,246					
1897	222,077	3,380	..	..	18,870,530	149,024	2,041	19	19,099,648	150,523					
1898	647,965	3,643	..	..	19,424,403	64,043	1,510	9	19,649,857	67,897					
1899	623,372	4,388	..	..	32,309,031	121,257	1,104	9	32,954,007	125,684					
1900	703,049	5,290	..	..	36,974,288	143,444	1,874	20	37,729,211	148,754					
1901	631,571	2,217	..	..	49,441,734	202,106	1,812	19	50,075,117	204,342					
1902	1,756,769	5,856	..	..	54,348,980	211,933	1,949	27	56,607,688	217,516					
1903	2,528,785	8,429	..	..	85,328,491	345,909	1,793	26	87,859,069	354,364					
1904	2,655,920	10,775	..	..	115,903,804	463,170	1,658	26	118,491,382	473,971					
1905	2,733,110	11,388	..	..	142,063,846	592,794	1,488	22	144,798,444	604,204					
1906	2,897,990	9,559	..	..	137,654,261	564,666	1,871	13	140,563,122	574,238					
1907	3,156,665	10,412	..	..	148,888,002	599,688	1,010	15	152,045,677	610,015					
1908	3,243,110	10,698	..	..	173,402,790	691,307	420	4	176,646,320	702,009					
1909	3,280,750	10,822	..	..	230,396,617	899,343	720	7	233,678,087	910,172					
1910	3,320,680	..	..	..	211,507,903	..	1,064	..	214,829,647	835,927					
1911	3,665,163	11,760	..	..	222,225,531	872,623	1,400	15	225,792,094	884,398					
1912	3,747,359	12,361	..	..	245,335,209	962,907	960	13	249,083,518	975,278					
1913	4,688,628	15,466	..	..	1,019,107	1,019,107	1,200	10	277,555,225	1,034,586					
1914	4,688,547	15,466	..	..	272,865,397	1,048,157	1,200	13	280,720,444	1,058,565					
1915	4,550,150	15,009	..	..	264,632,963	943,086	1,200	13	269,343,710	1,065,183					
1916	5,236,890	17,274	..	..	282,291,932	1,048,157	1,200	13	287,093,576	1,119,405					
1917	9,344,815	55,802	..	..	291,769,083	1,100,901	1,833,814	2,016	297,189,737	1,192,965					
1918	10,999,648	45,767	..	..	272,795,191	1,051,995	619,517	5,168	283,759,523	1,131,904					
1919	11,788,679	75,035.3	..	..	274,834,556	1,081,128	750,807	5,009	286,585,011	1,183,1307.8					
			..	..	293,743,807	1,757,338.4	114,330	1,436.1	305,681,316						

## MEXICO.

## QUANTITY OF CRUDE PETROLEUM PRODUCED.

Year.	Quantity. Metric Tons.	Year.	Quantity. Metric Tons.
1901, . . .	1,544	1910, . . .	542,400
1902, . . .	6,000	1911, . . .	1,873,552
1903, . . .	11,250	1912, . . .	2,471,375
1904, . . .	18,750	1913, . . .	3,835,267
1905, . . .	37,500	1914, . . .	3,915,732
1906, . . .	75,000	1915, . . .	4,912,016
1907, . . .	150,000	1916, . . .	6,059,589
1908, . . .	587,000	1917, . . .	8,264,266
1909, . . .	405,000	1918, . . .	9,506,289

AMOUNT OF PETROLEUM AND ITS PRODUCTS, IN AMERICAN GALLONS, IMPORTED BY MEXICO FROM THE UNITED STATES OF AMERICA FOR THE FISCAL YEARS ENDING 30TH JUNE 1900 TO 1918.

	1900.	1901.	1902.	1903.	1904.	1905.
	Gallons.	Gallons.	Gallons.	Gallons.	Gallons.	Gallons.
Crude oil, . . .	8,002,845	8,356,258	10,844,913	9,859,154	10,938,448	14,036,517
Naphtha, . . .	4,327	7,158	9,774	10,717	21,308	56,555
Illuminating oil, . . .	282,160	225,172	371,421	342,000	409,266	461,266
Lubricating oil, . . .	769,566	610,923	679,510	798,282	695,308	697,382
Residuum, . . .	..	..	..	..	..	..
Gasoline, . . .	..	..	..	..	..	..
Gas oil and fuel oil, . . .	..	..	..	..	..	..
Total, . . .	9,058,898	9,199,511	11,905,618	11,010,153	12,064,330	15,251,720

	1906.	1907.	1908.	1909.	1910.	1911.
	Gallons.	Gallons.	Gallons.	Gallons.	Gallons.	Gallons.
Crude oil, . . .	14,366,495	19,992,434	17,523,440	27,554,581	41,202,786	24,298,337
Naphtha, . . .	100,674	133,147	79,686	73,819	61,550	363,101
Illuminating oil, . . .	2,095,939	2,495,070	764,067	511,276	740,615	200,252
Lubricating oil, . . .	1,097,746	1,255,991	839,966	1,165,272	1,376,321	1,308,964
Residuum, . . .	..	..	..	..	155,072	1,023,559
Gasoline, . . .	..	..	..	..	..	..
Gas oil and fuel oil, . . .	..	..	..	..	..	..
Total, . . .	17,660,854	23,876,642	19,207,159	29,304,948	43,536,344	27,294,213

	1913.	1914.	1915.	1916.	1917.	1917. <sup>a</sup>	1918. <sup>a</sup>
	Gallons.	Gallons.	Gallons.	Gallons.	Gallons.	Gallons.	Gallons.
Crude oil, . . .	16,138,930	14,900,388	5,707,481	12,050,278	2,705,957	2,004,464	2,192,802
Naphtha, . . .	67,419	45,446	81,615	181,145	224,827	230,059	420,185
Illuminating oil, . . .	1,225,289	971,355	1,763,624	1,357,976	506,273	845,220	1,982,913
Lubricating oil, . . .	889,577	791,556	797,894	681,388	637,389	644,201	894,576
Residuum, . . .	15,108	27,384	8,179	38,820	8,678	12,732	85,725
Gasoline, . . .	101,390	267,744	475,840	955,795	614,793	936,526	900,918
Gas oil & fuel oil, . . .	464	1,447,858	586,139	7,311,221	21,611,633	21,402,114	27,552,406
Total, . . .	18,438,177	18,451,731	9,420,772	22,576,623	26,309,550	26,125,316	34,029,525

<sup>a</sup> For the years ended December 31st.

JAPAN.

PRODUCTION OF PETROLEUM IN JAPAN.

Year.	Production.—Crude Oil.		Year.	Production.—Crude Oil.	
	Koku. <sup>a</sup>	Imperial Gallons.		Koku.	Imperial Gallons.
1875, . . .	4,830	191,751	1897, . . .	231,221	9,179,474
1876, . . .	8,155	323,753	1898, . . .	280,764	11,146,331
1877, . . .	10,114	401,526	1899, . . .	474,406 <sup>b</sup>	18,833,918
1878, . . .	18,920	751,124	1900, . . .	767,092	30,453,552
1879, . . .	24,816	985,195	1901, . . .	983,000	39,025,100
1880, . . .	26,974	1,070,868	1902, . . .	1,060,000	42,082,000
1881, . . .	17,721	703,524	1903, . . .	1,065,116	42,285,105
1882, . . .	16,450	653,065	1904, . . .	1,249,536 <sup>f</sup>	49,606,579
1883, . . .	21,659	859,862	1905, . . .	1,296,486	51,470,494
1884, . . .	29,541	1,172,778	1906, . . .	1,501,563	59,612,051
1885, . . .	30,931	1,227,961	1907, . . .	1,755,464	69,691,921
1886, . . .	40,113	1,592,486	1908, . . .	1,815,001	72,055,540
1887, . . .	30,304	1,203,069	1909, . . .	1,657,036	65,784,329
1888, . . .	39,605	1,572,318	1910, . . .	1,520,458	60,362,182
1889, . . .	55,871	2,218,079	1911, . . .	1,529,593	60,724,842
1890, . . .	54,399	2,159,640	1912, . . .	1,458,290	57,904,113
1891, . . .	55,983	2,222,525	1913, . . .	1,693,582	67,235,205
1892, . . .	72,893	2,893,852	1914, . . .	2,395,836	95,114,689
1893, . . .	94,145	3,737,556	1915, . . .	2,728,476	108,320,497
1894, . . .	151,986	6,033,844	1916, . . .	2,621,395	104,069,381
1895, . . .	149,497	5,935,031	1917, . . .	2,524,965	100,241,110
1896, . . .	208,500	8,277,450	1918, . . .	2,147,770	85,266,469

<sup>a</sup> Koku=39.7 imperial gallons.

<sup>b</sup> Represents the quantity of crude sold in 1899.

<sup>f</sup> Production of Echigo.

Note.—The production of Formosa is not included in the above figures.

PRODUCTION OF CRUDE PETROLEUM IN FORMOSA.

Year.	Quantity.	
	Koku.	Imperial Gallons.
1906, . . .	4,394	174,442
1907, . . .	6,717 <sup>a</sup>	266,665
1908, . . .	7,310	290,207
1909, . . .	5,664	224,861
1910, . . .	3,208	127,358
1911, . . .	1,442	57,247
1912, . . .	3,040	120,688
1913, . . .	15,933	632,540
1914, . . .	14,708	583,907
1915, . . .	16,651	661,044
1916, . . .	16,966	674,550
1917, . . .	12,340	489,898
1918, . . .	8,101	321,610

<sup>a</sup> Estimated.

## PERU.

PRODUCTION OF PETROLEUM IN PERU, 1905 TO 1919, in BARRELS OF  
42 U.S.A. GALLONS.

Year.	Lobitos.	Negritos.	Zorritos.	Lake Titicaca (Huancane).	Lagunitos.	Total.
1905 . . .	<i>a</i> 75,000	335,160	37,720	..	..	447,880
1906 . . .	162,000	330,510	42,419	1,365	..	536,294
1907 . . .	279,000	396,750	65,476	15,000	..	756,226
1908 . . .	319,898	543,750	71,429	<i>a</i> 76,103	..	1,011,180
1909 . . .	429,195	740,070	70,750	<i>a</i> 76,103	..	1,316,118
1910 . . .	400,080	773,025	107,000	<i>a</i> 50,000	..	1,330,105
1911 . . .	391,290	828,698	64,286	<i>a</i> 30,000	..	1,368,274
1912 . . .	587,048	1,071,000	78,095	<i>a</i> 15,000	..	1,751,143
1913 . . .	557,355	1,136,490	83,343	<i>a</i> 10,000	346,073	2,133,261
1914 . . .	504,743	1,032,210	88,136	<i>a</i> 10,000	282,713	1,917,802
1915 . . .	664,972	1,355,925	72,736	<i>a</i> 1,000	392,618	2,487,251
1916 . . .	654,060	<i>b</i> 1,822,733	73,852	..	..	2,550,645
1917 . . .	686,595	<i>b</i> 1,771,560	75,262	..	..	2,533,417
1918 . . .	639,098	<i>b</i> 1,820,814	76,190	..	..	2,536,102
1919 . . .	..	..	..	..	..	2,561,291

*a* Estimated.*b* Includes Lagunitos.

## PRODUCTION OF PETROLEUM IN THE ZORRITOS FIELD OF PERU FROM THE YEAR 1896.

Year.	Crude Oil.	Refined.	Lubricating Oil.	Benzine.	Gasoline.
	Gallons.	Gallons.	Gallons.	Gallons.	Gallons.
1896, . . .	1,996,520	608,900	896,450	4,560	..
1897, . . .	2,874,980	959,645	964,680	7,940	..
1898, . . .	2,880,000	600,000	1,250,000	8,350	..
1899, . . .	3,745,000	806,900	2,541,000	11,220	..
1900, . . .	4,325,000	<i>a</i> 400,000	..	13,000	..
1901, . . .	3,135,000	<i>a</i> 282,430	..	19,060	..
1902, . . .	2,489,500	<i>a</i> 373,250	..	25,920	..
1903, . . .	2,060,000	<i>a</i> 276,100	..	61,745	..
1904, . . .	2,080,000	<i>a</i> 365,000	..	46,200	..
1905, . . .	1,584,242	300,000	..	29,570	..
1906, . . .	1,781,600	350,000	..	10,000	54,000
1907, . . .	2,750,000	420,000	..	20,000	101,000
1908, . . .	3,000,000	500,000	..	30,000	150,000
1909, . . .	2,971,510	469,610	..	..	96,520
1910, . . .	<i>b</i> 4,494,000	..	..	..	..
1911, . . .	2,700,000	650,000	..	200,000	..
1912, . . .	3,280,000	476,620	..	..	226,440
1913, . . .	3,500,424	565,320	..	..	324,000
1914, . . .	3,701,718	482,850	..	..	277,440
1915, . . .	3,054,900	461,510	..	..	362,230
1916, . . .	3,101,790	468,790	..	..	396,720
1917, . . .	3,161,017	377,645	..	..	461,206
1918, . . .	<i>c</i> 3,200,000	..	..	..	..

*a* In view of the large stock on hand of kerosene the manufacture of burning oil was materially reduced, and the whole of the residue was marketed as fuel oil.

*b* 107,000 barrels.

*c* Estimated.

GERMANY.

PRODUCTION AND VALUE OF CRUDE OIL IN GERMANY.

Year.	Elsass.		Hannover.		Bavaria.		Total Production.	Total Value.
	Pro-duction.	Value.	Pro-duction.	Value.	Pro-duction.	Value.		
	Metric Tons.	£.	Metric Tons.	£.	Metric Tons.	£.	Metric Tons.	£.
1880	1,053	..	256	..	..	..	1,309	7,950
1881	1,237	..	2,871	..	..	..	4,108	20,300
1882	2,169	..	5,989	..	..	..	8,158	37,550
1883	1,198	..	2,557	..	..	..	3,755	17,600
1884	2,775	..	3,715	..	..	..	6,490	27,550
1885	3,087	..	2,728	..	..	..	5,815	23,550
1886	7,696	..	2,689	..	..	..	10,385	48,100
1887	7,892	..	2,552	..	..	..	10,444	46,650
1888	9,150	..	2,770	..	..	..	11,920	51,400
1889	6,532	..	3,059	..	..	..	9,591	44,050
1890	12,977	..	2,249	..	..	..	15,226	62,100
1891	12,817	..	2,498	..	..	..	15,315	59,750
1892	12,942	..	1,315	..	..	..	14,257	44,000
1893	12,609	..	1,365	..	..	..	13,974	39,150
1894	15,632	40,664	1,600	7,958	..	..	17,232	48,622
1895	15,439	38,833	1,612	9,289	..	..	17,051	48,122
1896	18,883	50,052	1,512	9,373	..	..	20,395	59,425
1897	20,703	55,214	2,600	14,607	..	..	23,303	69,822
1898	23,232	64,747	2,545	14,102	12	60	25,789	78,910
1899	23,554	60,224	3,405	18,342	68	306	27,027	78,872
1900	22,597	64,282	27,731	121,786	47	235	50,375	186,304
1901	19,997	55,300	24,098	a92,223	..	..	44,095	147,523
1902	20,205	50,500	29,520	a117,050	..	..	49,725	167,550
1903	20,947	57,600	41,733	159,100	..	..	62,680	216,700
1904	22,016	66,050	67,590	224,150	..	..	89,606	290,200
1905	21,128	..	57,741	..	..	..	78,869	260,350
1906	a22,154	..	59,196	..	..	..	81,350	251,800
1907	a26,124	..	80,255	..	..	..	106,379	352,800
1908	a28,898	..	113,002	..	..	..	141,900	497,100
1909	a29,726	..	113,518	..	..	..	143,244	505,900
1910	33,492	..	110,996	..	..	..	144,488	..
1911	43,748	..	98,639	..	..	..	142,387	..
1912	47,176	..	82,438	..	..	..	129,614	..
1913	49,584	..	71,174	..	..	..	120,758	..
1914	49,054	..	61,130	..	..	..	110,184	..
1915	43,176	..	55,919	..	..	..	99,095	..
1916	41,579	..	51,243	..	..	..	92,822	..
1917	46,911	..	43,616	..	..	..	90,527	..
1918	51,193	..	38,027	..	..	..	89,220	..
1919	47,256	..	27,353	..	..	..	74,609	..

The value has been converted into £ sterling at the rate of 20 marks = £1.

a Includes the Bavarian production.

## CANADA.

## QUANTITY AND VALUE OF CRUDE PETROLEUM PRODUCED.

Year.	Quantity in Barrels of 35 Imperial Gallons.	Value. £.
1901, . . . .	756,679	252,746
1902, . . . .	530,624	196,121
1903, . . . .	486,637	216,283
1904, . . . .	552,575	202,950
1905, . . . .	634,095	176,500
1906, . . . .	569,753	157,064
1907, . . . .	788,872	217,956
1908, . . . .	527,987	154,041
1909, . . . .	420,755	115,382
1910, . . . .	315,895	80,113
1911, . . . .	291,096	74,390
1912, . . . .	243,336	71,885
1913, . . . .	228,080	84,675
1914, . . . .	<sup>a</sup> 214,805	71,484
1915, . . . .	215,464	62,619
1916, . . . .	198,123	81,726
1917, . . . .	213,832	112,966
1918, . . . .	304,741	184,405
1919, . . . .	237,738	..
1920, . . . .	<sup>b</sup> 198,400	..

<sup>a</sup> Includes 387 barrels from Alberta.

<sup>b</sup> Estimated.



ITALY.

PRODUCTION OF PETROLEUM IN ITALY FROM 1869 TO 1918.

Year.	Number of Mines in Operation.	Production.			Number of Workmen employed.	Province.				
		Quan- tity.	Unit Value.	Total Value.		Emilia.	Chieti.	Caserta.	Parma.	Piacenza.
		Metric Tons.	Lire.	Lire.		Metric Tons.	Metric Tons.	Metric Tons.	Metric Tons.	Metric Tons.
1869	8	20	800-00	16,000	45	20	..	..	..	..
1870	6	12	800-00	9,000	30	12	..	..	..	..
1871	6	38	263-16	10,000	40	8	..	30	..	..
1872	6	46	208-69	9,600	36	6	..	40	..	..
1873	5	65	172-31	11,200	35	5	..	60	..	..
1874	4	84	152-38	12,800	37	4	..	80	..	..
1875	3	113	138-05	15,600	38	3	..	110	..	..
1876	3	402	123-38	49,600	72	2	..	400	..	..
1877	2	408	132-35	54,000	45	8	..	400	..	..
1878	4	602	102-99	62,000	98	2	..	600	..	..
1879	4	402	124-37	50,000	70	2	..	400	..	..
1880	2	283	313-05	88,595	24	53	80	150	..	..
1881	2	172	445-00	76,540	24	50	58	64	..	..
1882	4	183	474-55	86,844	121	44	74	65	..	..
1883	5	225	259-49	58,387	92	39	125	61	..	..
1884	6	397 <sup>a</sup>	341-18	135,452	110	249	90	56	..	..
1885	6	270 <sup>b</sup>	407-65	110,066	136	112	100	57	..	..
1886	7	219	416-11	91,130	145	123	50	46	..	..
1887	7	208	364-04	75,720	135	158	20	30	..	..
1888	5	174	319-71	55,630	75	174	..	..	..	..
1889	7	177	288-13	51,000	70	177	..	..	..	..
1890	9	417	289-21	120,603	177	359	35	23	..	..
1891	10	1,155	301-38	348,100	251	1,016	60	24	..	..
1892	7	2,548	296-11	754,500	267	..	..	..	..	..
1893	8	2,652	299-80	795,050	130	..	..	..	..	..
1894	9	2,854	296-88	847,260	194	..	..	..	..	..
1895	6	3,594	258-90	930,496	134	3,532	62	..	..	..
1896	9	2,524 <sup>c</sup>	255-34	644,478	222	..	74	..	61	2,388
1897	8	1,932	255-33	492,288	231	..	61	..	80	1,791
1898	7	2,015	292-30	589,129	217	..	60	..	45	1,910
1899	6	2,242	264-97	594,062	231	..	363	..	73	1,806
1900	9	1,683	292-20	491,769	226	..	75	..	62	1,546
1901	9	2,246	298-78	671,065	227	..	40	..	59	2,147
1902	9	2,633	295-54	778,163	252	..	50	..	51	2,532
1903	10	2,486	296-57	737,293	282	..	37	..	54	2,395
1904	10	3,543	297-29	1,053,294	..	..	..	..	..	..
1905	9	6,122-5	298-37	1,826,802	..	..	..	..	..	..
1906	12	7,451-5	298-81	2,226,559	..	..	..	..	..	..
1907	13	8,326-5	199-75	1,663,300	..	..	..	..	..	..
1908	14	7,088	199-72	1,415,640	..	..	..	..	..	..
1909	12	5,895	199-94	1,178,660	..	..	..	..	..	..
1910	9	7,069	200-00	1,413,800	..	..	..	..	..	..
1911	9	10,390	140-00	1,454,600	..	..	..	..	..	..
1912	9	7,479	160-00	1,196,640	..	..	..	..	..	..
1913	9	6,564	250-00	1,641,000	..	..	..	..	..	..
1914	7	5,542	250-00	1,385,500	..	..	..	..	..	..
1915	7	6,105	280-54	1,712,700	..	..	..	..	..	..
1916	7	7,035	622-94	4,382,900	..	..	..	..	..	..
1917	6	5,669	..	..	..	..	..	..	..	..
1918 <sup>d</sup>	6	5,000	800-00	4,000,000	..	..	..	..	..	..

<sup>a</sup> This quantity of 397 tons included 2 tons (of the value of 1000 francs) produced on the ancient property of Caruso, in the territory of Lercara (Palermo).

<sup>b</sup> This quantity of 270 tons included 1 ton from the property of Caruso.

<sup>c</sup> One metric ton was produced in the mining district of Bologna.

<sup>d</sup> Estimated.

## HUNGARY.

## QUANTITY AND VALUE OF CRUDE PETROLEUM PRODUCED.

Year.	Quantity.	Value.
	Metric Tons.	£.
1898, . . . . .	2,471	5,075
1899, . . . . .	2,125	4,475
1900, . . . . .	2,197	4,658
1901, . . . . .	3,296	7,922
1902, . . . . .	4,347	8,692
1903, . . . . .	3,010	5,941
1904, . . . . .	2,134	4,629
1905, . . . . .	471	1,124
1906, . . . . .	2,691	5,953
1907, . . . . .	2,404	7,081
1908, . . . . .	2,427	5,516
1909, . . . . .	2,590	5,853
1910, . . . . .	2,501	5,508
1911, . . . . .	2,191	5,201
1912, . . . . .	2,793	8,796
1913, . . . . .	2,105	..

The value has been converted into £ sterling at the rate of 24.02 kronen = £1.

## UNITED KINGDOM.

## ANNUAL PRODUCTION AND VALUE OF CRUDE PETROLEUM IN THE UNITED KINGDOM FROM THE YEAR 1886. (From the official returns.)

Year.	Quantity.	Value.	Year.	Quantity.	Value.
	Tons.	£.		Tons.	£.
1886	43	129	1897	12	29
1887	66	99	1898	6	14
1888	35	..	1899	5	12
1889	30	45	1900	Nil.	..
1890	35	52	1901	8	19
1891	100	150	1902	25	60
1892	218	409	1903	Nil.	..
1893	260	488	1904	Nil.	..
1894	49	92	1905	46	69
1895	15	28	1906	10	15
1896	12	29			

From 1907 to 1918 no production was reported, but according to H.M. Petroleum Department, the production of petroleum at Hardstoft amounted to 216 tons in 1919 and 375 tons in 1920. A quantity of very light oil of paraffin base was also obtained at Ramsey, in Huntingdonshire, but no record of the output was kept.

Oil obtained from cannell coal by the Ministry of Munitions at Nottingham, Bradford, and Dundee amounted to 5467 tons in 1918 and 2211 tons in 1919.

## BARBADOS.

No figures are available as to the small amount of crude oil produced in the island.

TRINIDAD.

PRODUCTION OF PETROLEUM.

Year.	Quantity. Barrels of 42 U.S.A. Gallons.	Year.	Quantity. Barrels of 42 U.S.A. Gallons.
1908, . .	169	1914, . .	643,533
1909, . .	57,143	1915, . .	a750,000
1910, . .	142,857	1916, . .	928,581
1911, . .	285,307	1917, . .	1,602,312
1912, . .	436,805	1918, . .	2,082,068
1913, . .	503,616		

a Estimated.

PERSIA.

The following figures, which have been supplied by the Anglo-Persian Oil Company, Limited, give the production of crude petroleum :-

Year ending March 31st.	Quantity.	Year ending March 31st.	Quantity.
	Imperial Gallons.		Imperial Gallons.
1912 (7 months)	11,675,854	1917, . .	174,544,131
1913, . .	21,896,714	1918, . .	243,196,050
1914, . .	74,155,141	1919, . .	293,199,949
1915, . .	101,889,665	1920, . .	367,104,918
1916, . .	121,785,808		

ARGENTINA.

PRODUCTION OF PETROLEUM IN METRIC TONS.

Year.	Quantity.	Year.	Quantity.
	Metric Tons.		Metric Tons.
1907, . .	13	1913, . .	19,050
1908, . .	1,680	1914, . .	40,530
1909, . .	2,700	1915, . .	75,900
1910, . .	3,050	1916, . .	116,000
1911, . .	1,920	1917, . .	166,871
1912, . .	6,850	1918, . .	192,612

EGYPT.

PRODUCTION OF PETROLEUM.

Year.	Quantity.	Year.	Quantity.
	Metric Tons.		Metric Tons.
1911, . .	1,220	1916, . .	54,800
1912, . .	27,454	1917, . .	134,500
1913, . .	12,618	1918, . .	277,300
1914, . .	103,605	1919 to June 30,	128,349
1915, . .	34,961		

## VENEZUELA.

## PRODUCTION OF PETROLEUM FROM 1917 TO 1919.

Year.	Quantity.	
	Metric Tons.	
1917, . . . . .	18,255	
1918, . . . . .	50,710	
1919, . . . . .	64,628	

## NEWFOUNDLAND.

With the exception that 700 barrels of crude oil, valued at £233, were produced in 1904, no statistical evidence of the production of petroleum in the island is available.

## WORLD'S PRODUCTION OF PETROLEUM IN 1916.

Country.	Quantity.				Percentage of Total.
	Imperial Gallons.		Metric Tons.		
UNITED STATES—					
Appalachian field, . . . . .	805,008,792		3,067,927		
Lima-Indiana field, . . . . .	136,620,435		520,667		
Illinois, . . . . .	619,750,226		2,361,898		
Mid-Continent field, . . . . .	4,790,788,283		18,257,926		
Gulf, . . . . .	761,578,606		2,902,413		
California, . . . . .	3,182,044,433		12,126,925		
Rocky Mountain, . . . . .	226,579,447		863,505		
Other fields, . . . . .	269,567		1,027		
	<b>10,522,639,789</b>	<b>10,522,639,789</b>	<b>40,102,288</b>	<b>40,102,288</b>	<b>63.368</b>
RUSSIA, . . . . .		2,547,019,633		9,935,656	15.700
MEXICO, . . . . .		1,518,079,746		6,059,589	9.575
EASTERN ARCHIPELAGO, . . . . .		466,622,921		1,820,247	2.876
RUMANIA, . . . . .		402,018,850		a1,550,000	2.449
BRITISH INDIA, . . . . .		297,189,787		1,118,865	1.768
GALICIA, . . . . .		230,377,903		898,670	1.420
PERSIA, . . . . .		a 161,000,000		617,089	0.976
JAPAN, . . . . .	104,069,381		396,523		
FORMOSA, . . . . .	674,550		2,570		
	<b>104,743,931</b>	<b>104,743,931</b>	<b>399,093</b>	<b>399,093</b>	<b>0.630</b>
PERU, . . . . .		89,237,032		340,086	0.537
TRINIDAD, . . . . .		34,679,452		123,811	0.195
ARGENTINE, . . . . .		26,919,598		116,000	0.183
GERMANY, . . . . .		22,992,972		92,822	0.147
EGYPT, . . . . .		13,574,528		54,800	0.087
CANADA, . . . . .		6,934,305		27,050	0.043
ITALY, . . . . .		1,938,689		7,035	0.011
HUNGARY, . . . . .		512,703		a 2,000	0.003
OTHER COUNTRIES, . . . . .		5,127,028		a 20,000	0.032
TOTAL, . . . . .		<b>16,449,416,750</b>		<b>63,285,101</b>	<b>100.000</b>

a Estimated.

## WORLD'S PRODUCTION OF PETROLEUM IN 1917.

Country.	Quantity.				Percentage of Total.
	Imperial Gallons.		Metric Tons.		
UNITED STATES—					
Appalachian field, . . .	872,278,124		3,324,294		
Lima-Indiana field, . . .	128,408,871		489,372		
Illinois, . . . . .	551,969,224		2,103,581		
Mid-Continent field, . . .	5,720,428,088		21,800,827		
Gulf, . . . . .	851,659,965		3,245,717		
California, . . . . .	3,284,399,929		12,517,006		
Rocky Mountain, . . . . .	321,847,059		1,226,575		
Other fields, . . . . .	360,356		1,373		
	<b>11,731,351,616</b>	<b>11,731,351,616</b>	<b>44,708,745</b>	<b>44,708,745</b>	<b>64.820</b>
RUSSIA . . . . .		<i>a</i> 2,448,600,000		9,551,727	13.848
MEXICO, . . . . .		2,070,406,892		8,264,266	11.982
EASTERN ARCHIPELAGO, . . . . .		455,919,736		1,778,495	2.579
BRITISH INDIA, . . . . .		282,759,523		1,064,537	1.543
PERSIA, . . . . .		<i>a</i> 226,000,000		866,225	1.256
GALICIA, . . . . .		212,676,580		829,629	1.203
RUMANIA, . . . . .		134,220,088		<i>a</i> 517,491	0.750
JAPAN, . . . . .	100,241,110		381,936		
FORMOSA, . . . . .	489,898		1,867		
	<b>100,731,008</b>	<b>100,731,008</b>	<b>383,803</b>	<b>383,803</b>	<b>0.556</b>
PERU, . . . . .		88,634,127		337,789	0.490
TRINIDAD, . . . . .		56,058,488		213,642	0.310
ARGENTINE, . . . . .		38,725,004		166,871	0.242
EGYPT, . . . . .		33,317,045		134,500	0.195
GERMANY, . . . . .		22,424,477		90,527	0.131
CANADA, . . . . .		7,484,120		29,195	0.042
VENEZUELA, . . . . .		4,625,906		18,255	0.027
ITALY, . . . . .		1,462,250		5,669	0.008
HUNGARY, . . . . .		512,703		<i>a</i> 2,000	0.003
OTHER COUNTRIES, . . . . .		2,563,514		<i>a</i> 10,000	0.015
<b>TOTAL, . . . . .</b>		<b>17,918,473,077</b>		<b>68,973,366</b>	<b>100.000</b>

*a* Estimated.

## WORLD'S PRODUCTION OF PETROLEUM IN 1918.

Country.	Quantity.				Percentage of Total.
	Imperial Gallons.		Metric Tons.		
UNITED STATES—					
Appalachian field, . . .	888,695,689		3,386,862		
Lima-Indiana field, . . .	112,680,180		429,430		
Illinois, . . . . .	467,621,966		1,782,130		
Mid-Continent field, . . .	6,275,897,067		23,917,746		
Gulf, . . . . .	846,927,793		3,227,683		
California, . . . . .	3,412,254,447		13,004,266		
Rocky Mountain, . . . . .	448,132,036		1,707,853		
Other fields, . . . . .	277,894		1,059		
	<u>12,452,487,072</u>	<u>12,452,487,072</u>	<u>47,457,029</u>	<u>47,457,029</u>	<u>67.681</u>
MEXICO, . . . . .		2,381,564,953		9,506,289	13.557
RUSSIA, . . . . .		<i>a</i> 1,415,400,000		5,525,227	7.880
EASTERN ARCHIPELAGO, . . . .		470,895,530		1,836,914	2.620
RUMANIA, . . . . .		314,928,339		<i>a</i> 1,214,219	1.732
PERSIA, . . . . .		<i>a</i> 290,000,000		1,111,529	1.586
BRITISH INDIA, . . . . .		286,585,011		1,078,940	1.539
GALICIA, . . . . .		199,349,126		777,640	1.109
PERU, . . . . .		88,728,247		338,147	0.482
JAPAN, . . . . .	85,266,469		324,880		
FORMOSA, . . . . .	321,610		1,225		
	<u>85,588,079</u>	<u>85,588,079</u>	<u>326,105</u>	<u>326,105</u>	<u>0.465</u>
TRINIDAD, . . . . .		72,843,231		277,609	0.396
EGYPT, . . . . .		68,690,086		277,300	0.395
ARGENTINE, . . . . .		44,698,600		192,612	0.275
GERMANY, . . . . .		22,100,719		89,220	0.127
VENEZUELA, . . . . .		12,850,160		50,710	0.072
CANADA, . . . . .		10,665,935		41,606	0.060
ITALY, . . . . .		1,377,889		<i>a</i> 5,000	0.007
HUNGARY, . . . . .		512,703		<i>a</i> 2,000	0.003
OTHER COUNTRIES, . . . . .		2,563,514		<i>a</i> 10,000	0.014
TOTAL, . . . . .		<u>18,221,829,194</u>		<u>70,118,096</u>	<u>100.000</u>

*a* Estimated.

NATURAL GAS.

APPROXIMATE VALUE OF NATURAL GAS PRODUCED IN THE UNITED STATES, FROM 1905 TO 1910.

Localities.	1905.	1906.	1907.	1908.	1909.	1910.
Pennsylvania, . . . . .	Dollars. 19,197,336	Dollars. 18,558,245	Dollars. 18,844,156	Dollars. 19,104,944	Dollars. 20,475,207	Dollars. 21,037,211
New York, . . . . .	623,251	672,795	766,157	959,280	1,222,666	1,678,720
Ohio, . . . . .	5,721,462	7,145,809	8,718,562	8,244,835	9,966,938	8,626,954
West Virginia, . . . . .	10,075,804	13,735,343	16,670,962	14,837,130	17,538,565	23,816,553
Illinois, . . . . .	7,223	87,211	143,577	446,077	644,401	613,642
Indiana, . . . . .	3,094,134	1,750,715	1,572,605	1,312,607	1,616,903	1,473,403
Kansas, . . . . .	2,261,836	4,010,986	6,198,583	7,691,587	8,293,846	7,755,367
Missouri, . . . . .	7,390	7,210	17,010	22,592	10,025	12,611
California, . . . . .	133,696	134,560	168,397	307,652	446,933	476,697
Alabama, . . . . .						
Texas, . . . . .	14,409	150,695	178,276	236,837	453,253	956,683
Louisiana, . . . . .	1,500					
Kentucky, . . . . .	237,290	287,501	380,176	424,271	485,192	456,293
Tennessee, . . . . .	300	300	300	350	350	300
Arkansas and Wyoming, . . . . .	21,135	34,500	126,582	164,930	226,925	301,151
Colorado, . . . . .	20,752	22,800				
South Dakota, . . . . .	15,200	15,400	19,500	24,400	16,164	31,999
Oklahoma, . . . . .	130,137	259,862	417,221	860,159	1,806,193	3,490,704
North Dakota, . . . . .	..	..	235	2,480	3,025	7,010
Oregon, . . . . .	..	..	100	250	50	..
Iowa, . . . . .	..	..	..	93	50	40
Michigan, . . . . .	..	..	..	..	255	820
Total, . . . . .	41,562,855	46,873,932	54,222,399	54,640,374	63,206,941	70,756,158

## NATURAL GAS IN UNITED STATES.

APPROXIMATE VALUE OF NATURAL GAS PRODUCED IN THE UNITED STATES, FROM 1911 TO 1918.

Localities.	1911.	1912.	1913.	1914.	1915.	1916.	1917.	1918.
Pennsylvania, . . . . .	Dollars. 18,520,796	Dollars. 18,539,672	Dollars. 21,995,845	Dollars. 20,839,869	Dollars. 21,139,605	Dollars. 24,513,119	Dollars. 28,716,492	Dollars. 38,608,883
New York, . . . . .	1,418,767	2,343,379	2,425,633	2,600,352	2,335,252	2,355,320	2,499,303	5,673,131
Ohio, . . . . .	9,367,347	11,891,299	10,521,930	14,667,790	17,391,060	15,601,144	18,434,814	24,234,741
West Virginia, . . . . .	28,435,907	33,324,475	34,164,850	35,076,755	36,424,263	47,603,396	57,389,161	41,324,365
Illinois, . . . . .	687,726	616,467	574,015	437,275	350,371	396,357	479,072	620,949
Indiana, . . . . .	1,192,418	1,014,295	843,047	755,407	695,380	503,373	453,310	899,671
Kansas, . . . . .	4,854,534	4,264,706	3,288,394	3,340,025	4,037,011	4,855,389	5,701,436	6,640,781
Missouri, . . . . .	10,496	11,576	6,795	5,319	7,731	17,594	8,230	5,548
California, . . . . .	800,714	1,134,456	1,883,450	2,910,784	4,069,004	5,440,277	6,816,524	7,931,666
Kentucky, . . . . .	407,689	522,455	509,846	490,875	614,998	752,635	580,380	665,843
Tennessee, . . . . .	300	375	600	300	400	1,150	2,450	361,140
Texas, . . . . .	1,014,945	1,405,077	2,073,823	2,469,770	2,593,873	3,143,871	3,192,625	5,027,449
Louisiana, . . . . .	858,145	1,747,379	2,119,948	2,227,999	2,163,934	2,660,445	3,262,987	4,912,235
Alabama, . . . . .	16,984	30,412	31,166	27,220	36,445	31,573	25,213	1,890
South Dakota, . . . . .	5,738	309,816	269,421	214,103	59,898	86,077	144,425	19,109
North Dakota, . . . . .	295,858	7,406,528	7,436,389	8,050,039	193,092	210,964	315,612	475
Wyoming, . . . . .	6,731,770	120	120	200	275	12,014,706	13,984,656	2,575
Colorado, . . . . .	70	1,470	1,405	1,442	250	275	225	575,115
Arkansas, . . . . .	1,330	..	..	..	1,510	948	1,013	15,805,135
Oklahoma, . . . . .	..	..	..	..	2,500	38,855	81,406	245
Iowa, . . . . .	..	..	..	..	..	..	..	1,045
Michigan, . . . . .	..	..	..	..	..	..	..	62,148
Montana, . . . . .	..	..	..	..	..	..	..	..
Total, . . . . .	74,621,534	84,563,957	87,846,677	94,115,524	101,312,381	120,227,468	142,089,334	153,553,560

a Includes gas produced in Maryland, Utah, and Washington, valued at \$2700; and in Oregon, valued at \$550.



RECORD OF NATURAL GAS WELLS, IN THE UNITED STATES, IN 1917 AND 1918.

State.	Producing.			Drilled in 1917.			Abandoned in 1917.			Drilled in 1918.			Abandoned in 1918.
	Dec. 31, 1916.	Dec. 31, 1917.	Dec. 31, 1918.	Gas.	Dry.	Total.	Gas.	Dry.	Total.	Gas.	Dry.	Total.	
Alabama, . . . . .	19	24	23	5	..	5	..	..	4	4	4	8	5
Arkansas, . . . . .	119	113	110	5	3	8	..	11	6	6	..	6	9
California, . . . . .	110	111	111	10	2	12	..	9	18	18	3	21	18
Colorado, . . . . .	13	13	10	..	..	..	..	..	..	..	..	..	3
Illinois, . . . . .	341	287	254	18	58	76	..	72	11	11	21	32	44
Indiana, . . . . .	1,967	1,830	1,760	42	17	59	..	179	129	129	26	155	199
Iowa, . . . . .	6	7	8	2	1	3	..	1	2	2	..	2	1
Kansas, . . . . .	2,561	2,579	2,309	554	370	924	..	536	334	334	229	563	604
Kentucky, . . . . .	263	286	310	35	52	87	..	12	45	45	25	70	21
Louisiana, . . . . .	260	269	277	63	49	112	..	54	46	46	18	64	38
Maryland, . . . . .	..	..	3	..	..	..	..	..	3	3	..	3	..
Michigan, . . . . .	8	9	15	1	..	1	..	..	7	7	..	7	1
Missouri, . . . . .	54	47	40	1	1	2	..	8	..	..	..	..	7
Montana, . . . . .	13	15	13	3	2	5	..	1	2	2	..	4	4
New York, . . . . .	2,068	2,078	2,098	95	42	137	..	85	82	82	13	95	62
North Dakota, . . . . .	13	7	7	1	..	1	..	7	..	..	..	..	..
Ohio, . . . . .	6,053	5,979	6,168	552	254	806	..	626	614	614	297	911	425
Okahoma, . . . . .	1,344	1,433	1,598	350	376	726	..	261	401	401	340	801	296
Oregon, . . . . .	..	4	3	4	..	4	..	..	..	..	..	..	1
Pennsylvania, . . . . .	13,921	14,534	15,244	1,163	273	1,436	..	550	1,276	1,276	258	1,534	566
South Dakota, . . . . .	29	30	29	1	..	1	..	..	4	4	..	4	5
Tennessee, . . . . .	10	12	14	4	..	4	..	2	4	4	8	12	2
Texas, . . . . .	249	250	231	35	87	122	..	34	27	27	86	113	46
Utah, . . . . .	..	..	1	..	..	..	..	..	1	1	..	1	..
Washington, . . . . .	..	2	4	2	..	2	..	..	2	2	..	2	..
West Virginia, . . . . .	8,542	9,239	9,687	1,040	138	1,178	..	253	718	718	170	888	360
Wyoming, . . . . .	34	35	42	4	13	17	..	3	12	12	8	20	5
	37,997	39,283	40,369	3,990	1,738	5,728	..	2,704	3,808	3,808	1,508	5,316	2,722

## RECORD OF NATURAL GAS INDUSTRY IN PENNSYLVANIA, 1897 TO 1918.

Year.	Gas Produced.		Gas Consumed.			Wells.		Productive. Dec. 31.
	Number of Producers.	Value. Dollars.	Number of Consumers.		Value. Dollars.	Drilled.		
			Domestic.	Industrial.		Gas.	Dry.	
1897	176	6,242,543	a 201,059	1,124	5,392,661	314	96	2,467
1898	232	6,806,742	a 213,410	1,021	6,064,477	373	74	2,840
1899	281	8,337,210	a 232,060	1,236	7,926,970	467	104	3,303
1900	266	10,215,412	a 229,730	1,296	9,812,615	513	142	3,776
1901	296	12,688,161	a 326,912	1,743	11,785,996	600	143	4,436
1902	379	14,352,183	185,678	2,448	13,942,783	775	232	5,211
1903	414	16,182,834	214,432	2,834	16,060,196	699	126	5,910
1904	414	18,139,914	238,481	2,845	17,205,804	701	174	6,352
1905	351	19,197,336	257,416	2,929	19,237,218	765	168	6,566
1906	309	18,558,245	273,184	3,307	21,085,007	603	153	7,300
1907	344	18,844,156	295,115	3,812	22,917,547	769	180	8,051
1908	b 572	19,104,944	307,585	4,577	20,678,161	571	147	c 8,831
1909	b 777	20,475,207	294,781	5,377	21,639,102	756	166	c 9,499
1910	b 819	21,057,211	321,430	4,102	23,934,691	857	161	c 10,337
1911	b 1,067	18,520,796	320,537	4,597	23,940,001	832	224	c 10,885
1912	b 1,104	18,539,672	345,765	3,442	26,486,302	993	219	c 11,543
1913	b 1,174	21,695,845	400,823	4,373	28,709,565	1,011	259	c 12,438
1914	b 1,325	20,839,869	415,644	4,307	28,439,324	998	236	c 13,073
1915	b 1,396	21,139,605	440,673	4,696	30,087,667	863	188	c 13,431
1916	b 1,586	24,513,119	463,264	4,676	35,015,695	1,009	252	c 13,921
1917	b 1,613	28,716,492	480,500	4,417	40,773,689	1,163	273	c 14,534
1918	1,509	38,608,883	481,275	4,486	44,777,220	1,276	258	15,244

<sup>a</sup> Number of fires supplied.

<sup>b</sup> Includes 216 producers having shallow wells in Erie county for their own domestic consumption in 1908; 311 producers in 1909; 345 producers in 1910; 399 producers in 1911; and 401 producers in 1912, 1913, 1914, 1915, 1916, and 1917.

<sup>c</sup> Includes 350 shallow wells in Erie county in 1908; 429 wells in 1909 and 1910; 476 wells in 1911; 492 wells in 1912, 1913, 1914, and 1915; 483 wells in 1916; and 450 wells in 1917.

RECORD OF NATURAL GAS INDUSTRY IN INDIANA, 1897 TO 1918.

Year.	Gas Produced.		Gas Consumed.			Wells.		
	Number of Producers.	Value, Dollars.	Number of Consumers.		Value, Dollars.	Drilled.		Productive, Dec. 31.
			Domestic.	Industrial.		Gas.	Dry.	
1897	452	5,009,208	a 214,750	935	3,945,307	419	66	2,881
1898	533	5,060,969	a 173,454	1,867	4,682,401	706	111	3,325
1899	571	6,680,370	a 181,440	1,741	b 5,833,370	838	109	3,909
1900	670	7,254,539	a 181,751	2,751	b 6,412,307	861	156	4,546
1901	656	6,954,566	a 153,869	2,570	b 6,276,119	985	208	4,572
1902	929	7,081,344	101,481	3,282	b 6,710,080	1,331	205	5,820
1903	924	6,098,364	90,118	1,020	b 5,915,367	895	242	5,514
1904	846	4,342,409	84,862	390	b 4,282,409	706	153	4,684
1905	740	3,094,134	63,194	231	b 3,056,634	252	74	3,650
1906	578	1,750,715	47,368	156	b 1,750,755	159	46	3,523
1907	687	1,572,605	46,210	218	b 1,570,605	185	56	3,383
1908	823	1,312,507	42,054	216	b 1,312,507	187	41	3,226
1909	1,010	1,616,903	40,565	369	b 1,616,903	190	70	2,938
1910	1,027	1,473,403	36,054	282	b 1,473,403	69	33	2,955
1911	1,094	1,192,418	31,576	143	b 1,192,418	110	32	2,744
1912	1,140	1,014,295	27,165	140	b 1,014,295	96	39	2,547
1913	1,100	843,047	39,776	239	b 948,278	69	24	2,370
1914	1,029	755,407	43,410	344	b 1,422,880	68	19	2,224
1915	999	695,380	44,012	438	b 1,542,604	65	11	2,112
1916	995	503,373	44,118	471	1,746,285	43	14	1,967
1917	941	453,310	42,322	497	1,971,435	42	17	1,830
1918	931	889,671	31,032	284	1,510,404	129	26	1,760

a Number of fires supplied.

b Includes value of gas consumed in Chicago, Ill.

## RECORD OF NATURAL GAS INDUSTRY IN WEST VIRGINIA, 1897 TO 1918.

Year.	Gas Produced.		Gas Consumed.				Wells.		Productive. Dec. 31.
	Number of Producers.	Value, Dollars.	Number of Consumers.		Value, Dollars.	Drilled.			
			Domestic.	Industrial.		Gas.	Dry.		
1897	12	912,528	a 30,015	393	791,192	47	1	196	
1898	19	1,334,023	a 28,652	125	914,969	32	4	227	
1899	30	2,335,864	a 38,137	305	1,310,675	78	6	300	
1900	34	2,959,032	a 45,943	184	1,530,378	129	6	428	
1901	44	3,954,472	a 55,808	266	2,244,758	177	8	604	
1902	79	5,390,181	29,357	877	2,473,174	142	37	745	
1903	88	6,882,359	36,179	1,122	3,125,061	242	43	987	
1904	90	8,114,249	44,563	1,005	3,383,515	292	33	1,274	
1905	76	10,075,804	45,588	1,417	3,586,608	385	28	1,579	
1906	67	13,735,343	51,281	913	3,720,440	263	23	1,831	
1907	105	16,670,962	53,807	1,000	b 3,757,977	377	59	2,169	
1908	138	14,837,130	63,228	1,225	b 4,020,282	441	80	2,511	
1909	183	17,538,565	70,853	1,907	b 5,183,054	801	65	3,232	
1910	241	23,816,553	86,778	2,659	b 5,617,910	1,002	69	4,052	
1911	340	28,435,907	87,438	1,566	b 6,240,152	905	117	4,790	
1912	406	33,324,475	94,273	1,953	b 7,001,331	870	149	5,533	
1913	451	34,164,850	101,234	1,834	b 7,333,956	1,038	128	6,534	
1914	475	35,076,755	108,277	1,850	b 7,334,690	856	154	7,194	
1915	506	36,424,263	115,908	1,910	b 7,451,003	779	97	7,718	
1916	544	47,603,396	123,860	1,963	b 8,610,084	1,055	161	8,542	
1917	521	57,389,161	129,297	2,047	b 10,558,612	1,040	138	9,329	
1918	407	41,324,365	127,168	1,873	12,284,789	718	170	9,687	

a Number of fires supplied.

b Includes gas consumed in Maryland.

RECORD OF NATURAL GAS INDUSTRY IN OHIO, 1897 TO 1918.

NATURAL GAS : OHIO.

Year.	Gas Produced.		Gas Consumed.				Wells.		Productive. Dec. 31.
	Number of Producers.	Value. Dollars.	Number of Consumers.		Value. Dollars.	Drilled.			
			Domestic.	Industrial.		Gas.	Dry.		
1897	157	1,171,777	a 85,368	183	1,506,454	88	51	729	
1898	237	1,488,308	a 68,211	349	2,250,706	120	12	806	
1899	359	1,866,271	a 77,787	691	3,207,286	134	17	929	
1900	281	2,178,234	a 135,743	1,092	3,823,209	97	19	990	
1901	305	2,147,215	a 149,709	949	4,119,059	113	35	1,099	
1902	451	2,355,458	120,127	786	4,785,766	266	266	1,343	
1903	515	4,479,040	197,710	1,786	7,200,867	290	62	1,523	
1904	453	5,315,564	232,657	1,136	9,393,843	334	49	1,661	
1905	425	5,721,462	274,585	2,955	10,369,633	342	58	1,705	
1906	409	7,145,809	310,175	3,316	12,652,520	337	51	1,977	
1907	468	8,718,562	380,489	5,476	15,227,780	431	90	2,942	
1908	c 970	8,244,835	427,276	3,621	15,166,434	398	124	3,691	
1909	c 1,534	9,966,938	450,973	5,260	18,884,312	548	149	4,260	
1910	c 1,630	8,626,954	475,505	3,187	21,210,965	466	202	4,717	
1911	c 1,900	9,367,347	577,263	3,634	22,792,270	450	191	4,999	
1912	c 2,031	11,891,299	641,724	4,414	27,196,162	-637	289	5,163	
1913	c 2,056	10,521,930	685,956	5,010	27,055,824	408	235	5,308	
1914	c 2,268	14,667,790	734,354	6,102	29,936,642	686	257	5,809	
1915	c 2,499	17,391,060	773,548	5,621	31,900,764	800	260	6,064	
1916	c 2,503	15,601,144	836,828	4,602	37,394,410	593	204	6,053	
1917	c 2,320	18,434,814	872,073	4,743	44,742,782	552	254	5,979	
1918	2,359	24,234,741	885,876	4,010	43,694,161	614	297	6,168	

a Number of fires supplied.

b Exclusive of complete report of shallow wells.

c Includes 735 producers in Ashtabula, Erie, Huron, Lake, Lorain, and Cuyahoga counties having shallow wells for their own domestic purposes in 1908; 1239 in 1909; 1289 in 1910; 1476 in 1911; 1579 in 1912; 1600 in 1913; 1561 in 1914, 1915, and 1916; and 1506 in 1917.

d Includes 901 shallow wells located in Ashtabula, Erie, Huron, Lake, Lorain, and Cuyahoga counties in 1908; 1568 in 1909; 1541 in 1910; 1757 in 1911; 1773 in 1912; 1778 in 1913; 1733 in 1914, 1915, and 1916; and 1646 in 1917.

## RECORD OF NATURAL GAS INDUSTRY IN NEW YORK, 1897 TO 1918.

Year.	Gas Produced.		Gas Consumed.				Wells.		Productive, Dec. 31.
	Number of Producers.	Value, Dollars.	Number of Consumers.		Value, Dollars.	Drilled.			
			Domestic.	Industrial.		Gas.	Dry.		
1897	41	200,076	<i>a</i> 55,086	80	874,617	33	7	359	
1898	62	229,078	<i>a</i> 68,662	103	1,006,567	63	9	422	
1899	84	294,593	<i>a</i> 76,544	121	1,236,007	36	7	447	
1900	89	335,367	<i>a</i> 89,837	138	1,456,286	57	11	504	
1901	114	293,232	<i>a</i> 95,161	98	1,694,925	53	14	557	
1902	116	346,471	50,536	215	1,723,709	69	8	626	
1903	144	493,686	57,935	208	1,944,667	75	11	700	
1904	153	522,575	67,203	451	2,222,980	78	12	744	
1905	148	623,251	67,848	447	2,434,894	89	17	839	
1906	143	672,795	74,538	95	2,654,115	64	14	919	
1907	208	766,157	83,805	155	3,098,533	61	13	1,049	
1908	215	959,280	91,391	213	3,281,312	68	19	1,211	
1909	282	1,222,666	92,958	570	3,286,523	86	18	1,340	
1910	273	1,678,720	106,538	717	3,963,872	97	20	1,411	
1911	302	1,418,767	116,314	208	4,276,324	167	53	1,531	
1912	332	2,343,379	129,930	805	4,866,821	218	54	1,736	
1913	366	2,425,633	136,830	639	4,888,412	200	54	1,929	
1914	367	2,600,352	146,236	666	5,510,204	178	55	2,031	
1915	346	2,335,252	153,972	815	5,676,097	176	50	2,046	
1916	360	2,355,320	159,886	676	6,230,826	106	35	2,068	
1917	349	2,499,303	164,308	698	6,912,540	95	42	2,078	
1918	342	5,673,131	169,308	641	6,779,207	82	13	2,098	

*a* Number of fires supplied.

## RECORD OF NATURAL GAS INDUSTRY IN KANSAS, 1897 TO 1918.

Year.	Gas Produced.		Gas Consumed.				Wells.		Productive. Dec. 31.
	Number of Producers.	Value, Dollars.	Number of Consumers.		Value, Dollars.	Drilled.			
			Domestic.	Industrial.		Gas.	Dry.		
1897	10	105,700	a 3,956	20	105,700	16	8	90	
1898	29	174,640	a 6,186	44	174,640	34	18	121	
1899	31	332,592	a 10,071	71	332,592	44	22	160	
1900	32	356,900	a 9,703	65	356,900	54	15	209	
1901	48	659,173	a 10,227	72	659,173	71	35	276	
1902	80	824,431	13,488	91	824,431	144	63	404	
1903	120	1,123,849	15,918	143	1,123,849	295	66	666	
1904	190	1,517,643	27,204	298	1,517,643	378	135	1,029	
1905	171	2,261,836	46,852	601	2,265,945	340	157	1,142	
1906	130	4,010,986	79,270	990	b 4,023,566	331	99	1,495	
1907	196	6,198,583	149,327	1,605	b 6,208,862	361	163	1,760	
1908	212	7,691,587	168,855	1,162	b 7,691,587	403	208	1,917	
1909	199	8,293,846	182,657	1,160	b 8,356,076	452	214	2,138	
1910	204	7,755,367	186,333	1,412	c 9,335,027	392	195	2,149	
1911	232	4,854,534	199,523	907	c 9,493,701	301	152	2,033	
1912	253	4,264,706	195,446	1,104	c 8,521,858	435	200	2,106	
1913	305	3,288,394	195,131	950	c 6,983,802	506	253	2,297	
1914	353	3,340,025	187,714	1,079	b 7,163,746	445	219	2,261	
1915	371	4,037,011	201,133	1,446	b 8,174,289	554	194	2,443	
1916	414	4,855,389	202,222	1,354	b 9,731,518	461	193	2,561	
1917	462	5,701,436	188,043	1,018	b 8,463,767	554	370	2,579	
1918	412	6,640,781	120,350	877	7,064,218	334	229	2,309	

a Number of fires supplied.

b Includes gas taken from Kansas and consumed in Missouri.

c Includes gas taken from Kansas to Missouri; also gas piped from Oklahoma to Kansas and Missouri.

## RECORD OF NATURAL GAS INDUSTRY IN OKLAHOMA, 1906 TO 1918.

Year.	Gas Produced.		Gas Consumed.				Wells.		
	Number of Producers.	Value. Dollars.	Number of Consumers.		Value. Dollars.	Drilled.		Productive. Dec. 31.	
			Domestic.	Industrial.		Gas.	Dry.		
1906	50	259,862	8,391	202	247,282	81	33	239	
1907	107	417,221	11,038	277	406,942	99	41	a 344	
1908	115	860,159	17,567	356	860,159	73	40	b 374	
1909	131	1,806,193	33,907	1,527	1,743,963	97	35	454	
1910	168	3,490,704	38,617	1,557	1,911,044	93	58	509	
1911	204	6,731,770	44,854	1,507	2,092,603	303	143	732	
1912	242	7,406,528	47,017	1,651	3,149,376	329	197	936	
1913	347	7,436,389	49,308	1,793	3,740,981	423	298	1,052	
1914	437	8,050,039	62,390	1,951	c 4,226,318	388	182	1,205	
1915	434	9,195,804	67,874	1,551	c 5,058,526	209	118	1,229	
1916	544	12,014,706	79,724	2,327	c 7,062,142	386	231	1,344	
1917	565	13,984,656	94,605	2,183	c 10,900,827	350	376	1,433	
1918	393	15,805,135	120,507	1,480	12,724,364	461	340	1,598	

a Includes 87 wells "shut in" in 1907.

b Includes 100 wells "shut in" in 1908.

c Includes some gas piped from Oklahoma to Missouri in 1914, 1915, 1916, and 1917; and from Arkansas to Oklahoma in 1917.



RECORD OF NATURAL GAS INDUSTRY IN KENTUCKY, 1906 TO 1918.

Year.	Gas Produced.		Gas Consumed.				Wells.		
	Number of Producers.	Value, Dollars.	Number of Consumers.		Value, Dollars.	Drilled.		Productive, Dec. 31.	
			Domestic.	Industrial.		Gas.	Dry.		
1906	45	287,501	17,216	18	287,501	..	..	166	
1907	38	380,176	19,279	239	380,176	31	14	179	
1908	38	424,271	21,778	42	424,271	19	23	218	
1909	38	485,192	25,639	137	695,577	26	7	212	
1910	47	456,293	27,961	112	908,293	23	12	241	
1911	74	407,689	41,201	70	901,759	19	8	255	
1912	88	522,455	45,603	103	1,070,664	22	27	267	
1913	93	509,846	54,446	146	1,225,116	23	7	274	
1914	101	490,875	78,505	128	1,787,308	10	1	276	
1915	86	614,998	84,666	117	1,942,423	6	1	262	
1916	107	752,635	85,583	125	2,331,687	13	7	263	
1917	118	580,380	90,041	124	3,114,402	35 *	52	286	
1918	122	665,843	90,849	100	3,093,393	45	25	310	

## RECORD OF NATURAL GAS INDUSTRY IN ILLINOIS, 1906 TO 1918.

Year.	Gas Produced.		Gas Consumed.				Wells.		
	Number of Producers.	Value. Dollars.	Number of Consumers.		Value. Dollars.	Drilled.		Productive. Dec. 31.	
			Domestic.	Industrial.		Gas.	Dry.		
1906	66	87,211	1,429	2	87,211	..	..	200	
1907	128	143,577	2,126	61	143,577	94	41	283	
1908	185	446,077	a 7,377	a 204	a 446,077	121	42	400	
1909	194	644,401	a 8,458	a 518	a 644,401	56	11	423	
1910	207	613,642	a 10,109	a 261	a 613,642	64	31	458	
1911	225	687,726	a 10,078	a 293	a 687,726	65	78	458	
1912	223	616,467	a 10,691	a 212	a 616,467	56	147	453	
1913	231	574,015	a 10,423	a 279	a 574,015	60	119	455	
1914	235	437,275	a 8,952	a 153	a 437,275	38	114	416	
1915	226	350,371	a 8,610	a 134	a 350,371	28	67	372	
1916	218	396,357	a 14,485	a 121	a 396,357	36	126	341	
1917	225	479,072	a 11,622	118	a 479,072	18	58	287	
1918	186	620,949	8,669	90	620,949	11	21	254	

a Includes number of consumers and value of gas consumed in Vincennes, Ind., and in 1916 includes some consumers who used mixed gas.

## CANADA.

## VALUE OF ANNUAL PRODUCTION OF NATURAL GAS.

Calendar Year.	Value in Dollars.	Calendar Year.	Value in Dollars.	Calendar Year.	Value in Dollars.
1892, . . .	150,000	1902, . . .	195,992	1912, . . .	2,362,700
1893, . . .	376,233	1903, . . .	202,210	1913, . . .	3,309,381
1894, . . .	313,754	1904, . . .	323,376	1914, . . .	3,484,727
1895, . . .	423,032	1905, . . .	379,561	1915, . . .	3,706,035
1896, . . .	276,301	1906, . . .	583,523	1916, . . .	3,924,632
1897, . . .	325,873	1907, . . .	815,032	1917, . . .	5,045,298
1898, . . .	322,123	1908, . . .	1,012,660	1918, . . .	4,350,940
1899, . . .	387,271	1909, . . .	1,207,029	1919, . . .	4,071,572
1900, . . .	417,094	1910, . . .	1,346,471		
1901, . . .	339,476	1911, . . .	1,917,678		

## STATISTICS OF NATURAL GAS PRODUCTION IN THE PROVINCE OF ONTARIO, CANADA, 1902 TO 1918.

Year.	Producing Wells.	Miles of Gas Pipe.	Workmen employed.	Gas Produced.	
				Quantity. (Cubic feet.)	Value. Dollars.
1902	169	369	107	..	195,992
1903	210	312	138	..	196,535
1904	176	231	..	..	253,524
1905	273	462½	130	..	316,476
1906	332	550	108	2,534,200,000	533,446
1907	582	810	191	4,155,900,000	746,499
1908	656	850	152	4,483,000,000	988,616
1909	744	987	171	5,388,000,000	1,145,307
1910	828	982	186	7,263,427,000	1,271,303
1911	1,179	1,296	287	10,863,871,000	1,807,513
1912	1,247	1,448	277	12,529,463,000	2,036,245
1913	1,605	1,720	336	12,474,745,000	2,055,768
1914	1,665	1,380	392	14,094,521,000	2,215,808
1915	1,734	1,931	598	15,211,523,000	2,622,838
1916	1,802	2,233	653	17,838,318,000	2,730,653
1917	..	..	..	19,868,036,000	3,641,587
1918	1,891	..	510	13,029,524,000	2,884,460

## HUNGARY.

Definite figures regarding the production of natural gas are unavailable, but the output for 1915 is stated to have been 25,108,054 cubic metres.

## ITALY.

## PRODUCTION OF NATURAL GAS IN ITALY, 1903 TO 1915.

Year	Quantity. Cubic metres.	Year.	Quantity. Cubic metres.
1903, . .	2,255,596	1910, . .	8,840,000
1904, . .	2,551,396	1911, . .	9,021,000
1905, . .	3,092,000	1912, . .	6,800,000
1906, . .	5,723,469	1913, . .	6,015,000
1907, . .	5,710,000	1914, . .	5,920,000
1908, . .	6,737,500	1915, . .	5,812,000
1909, . .	8,268,000		

## UNITED KINGDOM.

## QUANTITY AND VALUE OF NATURAL GAS OBTAINED.

Year.	Quantity.	Value.	Year.	Quantity.	Value.
	Cubic Feet.	£.		Cubic feet.	£.
1900	Not stated.	..	1910	262,000	Not stated.
1901	Not stated.	..	1911	221,400	Not stated.
1902	150,000	30	1912	161,200	Not stated.
1903	972,460	194	1913	87,450	Not stated.
1904	774,800	155	1914	87,000	Not stated.
1905	Not stated.	..	1915	87,000	Not stated.
1906	Not stated.	..	1916	85,000	Not stated.
1907	Not stated.	..	1917	85,000	Not stated.
1908	Not stated.	..	1918	85,000	Not stated.
1909	236,800	Not stated.	1919	90,000	Not stated.

## EASTERN ARCHIPELAGO.

The production of natural gas for the years 1916 and 1917 was stated to be as follows :—

	1916. Metric Tons.	1917. Metric Tons.
Sumatra, . . . .	66,122·8	112,942·9
Java, . . . . .	24,371·3	30,674·9
Borneo, . . . . .	627·1	56,500·9
Total, . . . . .	91,121·2	200,118·7

## NATURAL-GAS GASOLINE.

NATURAL-GAS GASOLINE MARKETED IN THE UNITED STATES, 1911 TO 1918.

Year.	Number of Operators.		Plants.		Gasoline Produced.			Gas Used.			Average Yield in Gasoline per thousand Cubic Feet.
			Number.	Daily Capacity.	Quantity.	Value.	Price per Gallon.	Estimated Volume.	Value.		
1911	132	176		Gallons. 37,100	Gallons. 7,425,839	Dollars. 531,704	Cents. 7-16	Cubic Feet. 2,475,697,263	Dollars. 176,961	Gallons. 3-00	
1912	186	250		61,268	12,081,179	1,157,476	9-6	4,687,796,329	331,985	2-6	
1913	232	341		152,415	24,060,817	2,458,443	10-22	9,889,441,500	566,224	2-43	
1914	254	386		179,353	42,652,632	3,105,909	7-28	16,894,557,000	889,906	2-43	
1915	287	414		232,336	65,364,665	5,150,823	7-88	24,064,391,000	1,202,555	2-57	
1916	460	596		495,448	103,492,689	14,331,148	13-85	208,705,023,000	a 14,609,351	0-496	
1917	750	886		902,385	217,884,104	40,188,956	18-45	429,287,797,000	a 34,343,024	0-508	
1918	b 503	1,004		a 1,022,072	282,535,550	50,363,535	17-8	449,108,661,000	a 40,419,779	0-63	

a Estimated.

b This number is irrespective of the kind, number, and location of the plants operated, and cannot be compared with the previous years as they have not been listed in the same way.

PRODUCTION OF NATURAL-GAS GASOLINE IN THE UNITED STATES IN 1916, BY PRINCIPAL METHODS OF MANUFACTURE.  
*Gasoline Produced by Compression and by Vacuum Pumps.*

State.	Plants.			Gasoline Produced.			Gas Used.	
	Number.	Daily Capacity.	Quantity.	Value.	Price per Gallon.	Estimated Volume.	Average Yield in Gasoline per thousand Cubic Feet.	
Oklahoma, . . . . .	104	Gallons. 215,377	Gallons. 45,827,325	Dollars. 5,471,307	Cents. 11-94	Cubic Feet. 14,018,757,000	Gallons. 3-269	
West Virginia, . . . . .	133	39,276	9,289,624	1,642,031	17-67	3,550,523,000	2-616	
Pennsylvania, . . . . .	185	30,287	6,722,370	1,216,717	18-10	2,693,215,000	2-496	
Louisiana, . . . . .	7	10,661	213,159	269,564	12-76	907,153,000	2-329	
Texas, . . . . .	4	6,688	1,292,811	201,023	15-55	948,485,000	1-363	
New York, . . . . .	5	1,025	249,055	40,283	16-17	102,819,000	2-422	
Colorado, . . . . .	1							
California, . . . . .	24							
Ohio, . . . . .	53	72,251	19,428,443	2,652,776	13-65	14,492,463,000	..	
Illinois, . . . . .	29							
Kentucky, . . . . .	3							
Kansas, . . . . .	2							
	550	375,565	84,922,787	11,493,701	13-53	36,713,415,000	..	
<i>Gasoline Produced by Absorption. a</i>								
West Virginia, . . . . .	14	59,383	9,475,432	1,383,262	14-60	101,114,013,000	0-094	
Pennsylvania, . . . . .	10	16,200	2,992,556	509,456	17-02	35,797,406,000	0-084	
Oklahoma, . . . . .	12	17,700	2,532,227	393,838	15-55	10,730,697,000	0-236	
California, . . . . .	2							
Kentucky, . . . . .	2							
Illinois, . . . . .	3	26,600	3,569,637	550,891	15-43	24,349,492,000	..	
Ohio, . . . . .	2							
Kansas, . . . . .	1							
Grand total, . . . . .	46	119,883	18,569,902	2,837,447	15-28	171,991,608,000	..	
	596	495,448	103,492,689	14,321,148	13-85	208,705,023,000	0-496	

a Includes drip gasoline.

PRODUCTION OF NATURAL-GAS GASOLINE IN THE UNITED STATES IN 1917, BY PRINCIPAL METHODS OF MANUFACTURE.

Gasoline Produced by Compression and by Vacuum Pumps.

State.	Plants.			Gasoline Produced.				Gas Used.	
	Number.	Daily Capacity.	Quantity.	Value.	Price per Gallon.	Estimated Volume.	Average Yield in Gasoline per thousand Cubic Feet.		
Oklahoma, . . . . .	207	Gallons, 456,632	Gallons, 108,728,213	Dollars, 20,321,067	Cents, 18-68	Cubic Feet, 36,399,280,000	Gallons, 2-987		
California, . . . . .	40	82,092	23,478,521	3,637,827	15-49	27,477,443,000	0-854		
West Virginia, . . . . .	159	44,348	12,276,784	2,211,494	18-01	4,845,648,000	2-534		
Pennsylvania, . . . . .	234	32,564	9,011,199	1,792,430	19-89	3,572,356,000	2-862		
Louisiana, . . . . .	18	17,915	4,459,920	719,758	16-14	1,558,346,000	2-862		
Illinois, . . . . .	54	15,392	4,268,158	756,344	17-72	2,020,044,000	2-113		
Texas, . . . . .	8	10,900	3,942,337	664,543	16-86	2,666,983,000	1-478		
Ohio, . . . . .	54	8,337	2,331,498	423,106	18-15	836,639,000	2-787		
New York, . . . . .	5								
Kansas, . . . . .	1			70,361	19-02	150,784,000	2-453		
Kentucky, . . . . .	3								
Colorado, . . . . .	1								
	784	671,502	168,866,555	30,596,930	18-12	79,527,523,000	2-123		
<i>Gasoline Produced by Absorption.</i>									
West Virginia, . . . . .	29	91,315	20,391,803	4,300,319	21-09	162,925,703,000	0-125		
Oklahoma, . . . . .	27	35,804	6,395,211	1,220,838	19-09	48,320,661,000	0-132		
California, . . . . .	9	17,669	5,339,083	800,195	14-99	17,873,804,000	0-299		
Pennsylvania, . . . . .	17	26,600	4,815,051	985,668	20-47	45,914,700,000	0-105		
Kentucky, a . . . . .	2	613,000	3,725,893	745,210	20-00	24,871,590,000	0-106		
Ohio, . . . . .	7	16,800	3,108,062	628,270	20-21	29,225,502,000	0-106		
Texas, c . . . . .	3	21,650	2,978,068	484,898	16-28	10,010,233,000	0-298		
Kansas, . . . . .	5	3,842	1,071,633	220,550	20-58	9,274,289,000	0-116		
Illinois, a . . . . .	1	2,000	665,851	109,689	16-47	665,851,000	1-000		
Louisiana, a . . . . .	2	2,203	519,834	94,989	18-27	675,165,000	0-770		
New York, d . . . . .	..	..	7,000	1,400	20-00	2,776,000	..		
Grand total, . . . . .	102	230,883	49,017,549	9,592,026	19-57	349,760,274,000	0-140		
	886	902,385	217,884,104	40,188,956	18-45	429,287,797,000	0-508		

a Includes drip gasoline.  
 b Includes gasoline produced in Kentucky from West Virginia gas.  
 c Includes some gasoline produced by compression.  
 d Drip gasoline only.

PRODUCTION OF NATURAL-GAS GASOLINE IN THE UNITED STATES IN 1918, BY PRINCIPAL METHODS OF MANUFACTURE.

Gasoline Produced by Compression and by Vacuum Pumps.

State.	Number of Plants.	Gasoline Produced.			Gas Used.		
		Quantity.	Value.	Average Price per Gallon.	Estimated Volume.	Average Yield in Gasoline per thousand Cubic Feet.	
		Gallons.	Dollars.	Cents.	Cubic Feet.	Gallons.	
Oklahoma, . . . . .	238	154,271,905	26,521,398	17.2	46,684,983,000	3-30	
California, . . . . .	39	25,767,346	3,906,355	15.2	33,162,732,000	0-78	
West Virginia, . . . . .	172	11,612,114	2,191,367	18.9	5,218,740,000	2-23	
Pennsylvania, . . . . .	259	9,158,795	1,793,334	19.6	3,937,123,000	2-33	
Louisiana, . . . . .	15	5,903,723	847,509	14.4	1,906,837,000	3-10	
Illinois, . . . . .	72	4,574,565	890,436	19.5	2,316,646,000	1-97	
Texas, . . . . .	9	4,024,898	618,941	15.4	1,575,010,000	2-56	
Ohio, . . . . .	45	2,035,406	395,626	19.4	710,356,000	2-87	
Wyoming, . . . . .	2	1,306,063	211,230	16.2	613,175,000	2-13	
Kansas, . . . . .	6	802,773	200,693	25.0	3,626,789,000	0-22	
New York, . . . . .	3	211,131	54,006	25.6	96,711,000	2-18	
Kentucky, . . . . .	4	} 98,788	{ 13,754	} 13.6	{ 48,426,000	{ 2-01	
Colorado, . . . . .	1						} 25.1
	865	219,767,207	37,644,649	17.1	99,897,528,000	2-20	

Gasoline Produced by Absorption, a

West Virginia, . . . . .	36	25,991,789	5,307,437	20.4	158,710,810,000	0-16
Oklahoma, . . . . .	38	9,428,945	1,867,647	19.8	31,637,324,000	0-30
Pennsylvania, . . . . .	23	6,616,263	1,455,899	22.0	53,044,940,000	0-12
California, . . . . .	17	6,501,587	1,102,797	17.0	17,327,287,000	0-38
Ohio, . . . . .	10	4,709,501	959,821	20.4	37,028,966,000	0-13
Texas, . . . . .	4	3,301,224	595,624	18.0	6,918,172,000	0-48
Kentucky, . . . . .	2	3,234,673	646,973	20.0	19,768,711,000	0-16
Kansas, . . . . .	5	1,587,083	393,037	24.8	12,396,278,000	0-13
Louisiana, . . . . .	3	1,116,815	331,142	29.7	11,555,480,000	0-10
Wyoming, . . . . .	1	} 280,463	{ 58,509	} 20.9	{ 823,165,000	{ 2-52
New York, b	..					
	139	62,768,343	12,718,886	20.3	349,211,133,000	0-18
Grand total, . . . . .	1,004	282,535,550	50,363,535	17.8	449,108,661,000	0-63

a Includes drip gasoline.

b Drip gasoline only.



NATURAL-GAS GASOLINE MARKETED IN OKLAHOMA, 1911 TO 1918.

Year.	Plants.		Gasoline Produced.			Gas Used.		Average Yield in Gasoline per thousand Cubic Feet.	
	Number of Operators.	Number.	Daily Capacity.	Quantity.	Value.	Price per Gallon.	Estimated Volume.		Value.
1911	8	8	Gallons. 4,800	Gallons. 388,058	Dollars. 20,975	Cents. 5-40	Cubic Feet. 144,029,000	Dollars. 4,378	Gallons. 2-68
1912	11	13	11,910	1,575,644	99,626	6-3	701,044,300	24,901	2-25
1913	19	40	61,633	6,462,968	577,944	8-94	2,152,503,000	82,742	3-00
1914	35	58	74,793	17,277,555	1,113,059	6-44	5,738,549,000	273,940	3-01
1915	36	63	111,463	31,665,991	2,361,029	7-46	8,791,881,000	435,512	3-60
1916	77	116	233,077	48,359,602	5,865,145	12-13	24,749,454,000	..	1-954
1917	167	234	492,436	115,123,424	21,541,905	18-71	84,719,941,000	..	1-359
1918	133	276	..	163,700,550	28,389,045	..	78,322,307,000	..	2-09

NATURAL-GAS GASOLINE MARKETED IN WEST VIRGINIA, 1911 TO 1918.

Year.	Plants.		Gasoline Produced.			Gas Used.		Average Yield in Gasoline per thousand Cubic Feet.	
	Number of Operators.	Number.	Daily Capacity.	Quantity.	Value.	Price per Gallon.	Estimated Volume.		Value.
1911	47	72	Gallons. 16,819	Gallons. 3,660,165	Dollars. 262,661	Cents. 7-18	Cubic Feet. 1,252,900,600	Dollars. 76,074	Gallons. 2-92
1912	66	97	22,366	5,318,136	513,116	9-6	1,972,882,212	163,749	2-8
1913	63	115	31,930	7,662,493	807,406	10-54	2,981,119,000	181,337	2-57
1914	65	121	34,460	9,278,108	691,899	7-45	3,005,292,000	172,396	2-58
1915 <sup>a</sup>	66	114	34,422	10,853,608	927,079	8-54	3,526,575,000	150,918	2-30
1916	105	147	98,639	18,765,056	3,025,293	16-12	104,664,536,000	..	0-179
1917	128	188	135,663	32,668,647	6,511,813	19-93	167,771,351,000	..	0-195
1918	79	208	..	37,603,903	7,498,804	..	163,929,550,000	..	0-23

<sup>a</sup> Includes gasoline resulting from natural condensation in gas mains.

NATURAL-GAS GASOLINE MARKETED IN OHIO, 1911 TO 1918.

Year.	Number of Operators.	Plants.			Gasoline Produced.			Gas Used.		
		Number.	Daily Capacity.	Quantity.	Value.	Price per Gallon.	Estimated Volume.	Value.	Average Yield in Gasoline per thousand Cubic Feet.	
1911	26	39	Gallons. 6,454	Gallons. 1,678,985	Dollars. 118,161	Cents. 7-04	Cubic Feet. 469,672,000	Dollars. 37,574	Gallons. 3-57	
1912	25	43	7,791	1,718,719	173,421	10-1	576,123,700	46,090	2-98	
1913	25	41	8,142	2,072,687	212,404	10-25	744,226,000	63,233	2-79	
1914	25	47	9,319	2,440,171	184,097	7-54	852,277,000	68,935	2-86	
1915	29	50	8,995	2,198,715	167,138	7-60	785,041,000	..	2-80	
1916	40	55	18,391	2,638,571	470,804	17-84	5,435,759,000	..	0-485	
1917	49	61	25,137	5,439,560	1,051,376	19-33	30,062,141,000	..	0-181	
1918	36	55	..	6,744,907	1,355,447	..	37,739,322,000	..	0-18	

NATURAL-GAS GASOLINE MARKETED IN PENNSYLVANIA, 1911 TO 1918.

Year.	Number of Operators.	Plants.			Gasoline Produced.			Gas Used.		
		Number.	Daily Capacity.	Quantity.	Value.	Price per Gallon.	Estimated Volume.	Value.	Average Yield in Gasoline per thousand Cubic Feet.	
1911	43	50	Gallons. 5,669	Gallons. 1,467,043	Dollars. 109,649	Cents. 7-47	Cubic Feet. 526,152,663	Dollars. 52,615.	Gallons. 2-79	
1912	69	83	10,524	2,041,109	217,016	10-6	722,730,117	62,010	2-8	
1913	100	113	22,207	3,680,096	405,186	11-01	1,372,056,000	114,783	2-68	
1914	96	119	21,456	4,611,738	359,402	7-79	1,560,064,000	125,690	2-89	
1915 <sup>a</sup>	116	139	22,754	5,898,597	569,873	9-66	1,838,034,000	186,325	2-73	
1916	167	195	46,487	9,714,926	1,726,173	17-77	38,490,621,000	..	0-252	
1917	287	251	59,164	13,826,250	2,778,098	20-01	49,487,056,000	..	0-279	
1918	200	282	..	15,775,058	3,249,233	..	56,982,063,000	..	0-28	

<sup>a</sup> Includes gasoline resulting from natural condensation in gas mains.

NATURAL-GAS GASOLINE MARKETED IN CALIFORNIA, 1912 TO 1918.

Year.	Number of Operators.	Plants.		Gasoline Produced.			Gas Used.		
		Number.	Daily Capacity.	Quantity.	Value.	Price per Gallon.	Estimated Volume.	Value.	Average Yield in Gasoline per thousand Cubic Feet.
1912	7	7	Gallons. 6,669	Gallons. 1,040,695	Dollars. 112,502	Cents. 10-8	Cubic Feet. 600,743,000	Dollars. 25,573	Gallons. 1-7
1913	12	14	21,135	3,460,747	376,227	10-87	2,436,445,000	106,539	1-42
1914	17	19	32,360	7,581,309	633,517	8-36	5,129,709,000	197,066	1-48
1915	18	20	40,755	12,835,126	975,397	7-60	8,006,888,000	288,669	1-60
1916	28	26	54,060	17,158,754	2,293,822	13-37	24,826,354,000	..	0-691
1917	45	49	99,761	28,817,604	4,438,022	15-40	45,351,247,000	..	0-635
1918	29	56	..	32,268,933	5,009,152	..	50,490,019,000	..	0-64

NATURAL-GAS GASOLINE MARKETED IN ILLINOIS, 1914 TO 1918.

Year.	Number of Operators.	Plants.		Gasoline Produced.			Gas Used.		
		Number.	Daily Capacity.	Quantity.	Value.	Price per Gallon.	Estimated Volume.	Value.	Average Yield in Gasoline per thousand Cubic Feet.
1914	7	14	Gallons. 5,300	Gallons. 1,164,178	Dollars. 100,331	Cents. 8-62	Cubic Feet. 462,321,000	Dollars. 43,017	Gallons. 2-52
1915	8	16	8,500	1,935,204	80,049	7-73	451,663,000	34,405	2-29
1916	17	32	12,070	2,260,288	262,664	11-58	1,338,594,000	..	1-688
1917	33	55	17,392	4,934,009	866,033	17-55	2,685,895,000	..	1-837
1918	34	72	..	4,574,565	890,436	..	2,310,046,000	..	1-97

## NATURAL-GAS GASOLINE MARKETED IN LOUISIANA, 1916 TO 1918.

Year.	Number of Oper-ators.	Plants.		Gasoline Produced.			Gas Used.	
		Number.	Daily Capacity.	Quantity.	Value.	Price per Gallon.	Estimated. Volume.	Average yield in Gasoline per thousand Cubic Feet.
1916	7	7	Gallons. 10,661	Gallons. 2,113,159	Dollars. 269,564	Cents. 12-76	Cubic Feet. 907,153,000	Gallons. 2-329
1917	15	20	20,118	4,979,754	814,747	16-36	2,233,511,000	2-229
1918	9	18	..	7,020,538	1,178,651	..	13,462,317,000	0-52

## NATURAL-GAS GASOLINE MARKETED IN TEXAS, 1916 TO 1918.

Year.	Number of Oper-ators.	Plants.		Gasoline Produced.			Gas Used.	
		Number.	Daily Capacity.	Quantity.	Value.	Price per Gallon.	Estimated. Volume.	Average yield in Gasoline per thousand Cubic Feet.
1916	3	4	Gallons. 6,688	Gallons. 1,292,811	Dollars. 201,023	Cents. 15-55	Cubic Feet. 948,485,000	Gallons. 1-363
1917	10	11	32,550	6,920,405	1,149,441	16-61	12,677,216,000	0-546
1918	8	13	..	7,326,122	1,214,565	..	8,493,182,000	0-86

## NATURAL-GAS GASOLINE MARKETED IN KENTUCKY, 1916 TO 1918.

Year.	Number of Oper-ators.	Plants.		Gasoline Produced.			Gas Used.	
		Number.	Daily Capacity.	Quantity.	Value.	Price per Gallon.	Estimated. Volume.	Average yield in Gasoline per thousand Cubic Feet.
1916	5	5	Gallons. 11,300	Gallons. 725,467	Dollars. 141,347	Cents. 19-48	Cubic Feet. 5,614,613,000	Gallons. 0-129
1917	5	5	13,400	3,818,209	763,186	19-99	24,915,946,000	0-153
1918	5	6	..	3,330,986	660,108	..	19,816,518,000	0-16

## NATURAL-GAS GASOLINE MARKETED IN KANSAS, 1916 TO 1918.

Year.	Number of Oper-ators.	Plants.		Gasoline Produced.			Gas Used.	
		Number.	Daily Capacity.	Quantity.	Value.	Price per Gallon.	Estimated. Volume.	Average yield in Gasoline per thousand Cubic Feet.
1916	4	3	Gallons. 3,030	Gallons. 215,000	Dollars. 35,030	Cents. 16-29	Cubic Feet. 1,626,635,000	Gallons. 0-132
1917	4	6	4,642	1,174,980	241,219	20-53	9,315,339,000	0-126
1918	5	11	..	2,389,856	593,730	..	16,023,067,000	0-15

In many instances it has been found impossible to obtain later statistics than those given for the production of ozokerite, asphalt, and oil-shale.

**OZOKERITE.**

AUSTRIA.

QUANTITY AND VALUE OF OZOKERITE PRODUCED IN GALICIA.

Year.	Quantity.	Value.	Year.	Quantity.	Value.
	Metric Tons.	£.		Metric Tons.	£.
1901	2,707	107,096	1909	2,115	112,689
1902	2,655	121,663	1910	2,171	121,714
1903	2,849	181,107	1911	1,940	108,846
1904	3,086	196,942	1912	1,683	102,443
1905	2,957	172,005	1913	1,353	99,311
1906	2,698	139,565	1914	810	..
1907	2,508	129,771	1915	59	..
1908	2,592	134,923	1916	246	..

RUSSIA.

QUANTITY AND VALUE OF OZOKERITE PRODUCED.

Year.	Quantity.	Value.	Year.	Quantity.	Value.
	Metric Tons.	£.		Metric Tons.	£.
1900	Not stated.	..	1905	Not stated.	..
1901	Not stated.	..	1906	223	4,746
1902	183	7,336	1907	498	Not stated.
1903	86	2,141	1908	618	Not stated.
1904	Not stated.	..			

**ASPHALT.**

AUSTRIA.

QUANTITY AND VALUE OF ASPHALT PRODUCED.

Year.	Quantity.	Value.	Year.	Quantity.	Value.
	Metric Tons.	£.		Metric Tons.	£.
1898	643	1,299	1906	2,840	2,562
1899	2,635	3,150	1907	3,858	3,482
1900	887	1,999	1908	3,695	2,864
1901	541	1,611	1909	2,975	2,555
1902	897	1,695	1910	1,066	1,795
1903	1,273	2,248	1911	1,740	3,241
1904	1,434	2,892	1912	4,234	6,043
1905	4,363	2,730	1913	3,026	..

The value has been converted into £ sterling at the rate of 24.02 kronen=£1.

BARBADOS.

QUANTITY AND VALUE OF MANJAK EXPORTED FROM BARBADOS.

Year.	Quantity.	Value.	Year.	Quantity.	Value.
	Tons.	£.		Tons.	£.
1896	878	1,756	1905	929	9,292
1897	1,880	3,760	1906	782	7,820
1898	1,160	2,320	1907	693	6,930
1899	1,026	4,617	1908	430	4,304
1900	1,120	6,162	1909	342	2,492
1901	1,044	9,394	1910	174	1,306
1902	868	7,817	1911	164	1,568
1903	650	6,508	1912	158	1,741
1904	501	5,012			

COLOMBIA.

Since 1903 a deposit of asphalt has been worked near Chaparral, Tolima, and about 2000 tons have been shipped per annum.

## CUBA.

## QUANTITY AND VALUE OF ASPHALT EXPORTED.

Year.	Quantity.	Value.	Year.	Quantity.	Value.
	Metric Tons.	£.		Metric Tons.	£.
1900	Not stated.	..	1907	5,054	7,725
1901	Not stated.	..	1908	6,237	6,488
1902	Not stated.	..	1909	10,796	9,914
1903	4,790	7,111	1910	2,105	2,812
1904	8,926	24,493	1911	3,300	4,506
1905	10,142	17,981	1912	15,658	17,980
1906	5,186	5,467			

## FRANCE.

## PRODUCTION OF ASPHALTUM.

Year.	Metric Tons.	Year.	Metric Tons.
1904, . . . . .	22,000	1912, . . . . .	31,535
1905, . . . . .	20,000	1913, . . . . .	30,892
1906, . . . . .	38,231	1914, . . . . .	22,170
1907, . . . . .	33,000	1915, . . . . .	10,179
1908, . . . . .	41,000	1916, . . . . .	17,559
1909, . . . . .	44,800	1917, . . . . .	12,964
1910, . . . . .	38,500	1918, . . . . .	11,961
1911, . . . . .	39,000	1919, . . . . .	11,065

## GERMAN EMPIRE.

## QUANTITY AND VALUE OF ASPHALT PRODUCED.

Year.	Quantity.	Value.	Year.	Quantity.	Value.
	Metric Tons.	£.		Metric Tons.	£.
1898	67,649	20,817	1906	117,412	55,200
1899	74,770	26,047	1907	126,649	54,350
1900	89,685	32,000	1908	89,009	38,700
1901	90,193	33,750	1909	77,537	36,350
1902	88,374	30,200	1910	81,208	31,350
1903	87,454	40,600	1911	81,902	32,550
1904	91,736	44,550	1912	96,117	41,250
1905	103,006	49,500			

Value converted into £ sterling at the rate of 20 marks=£1.

## HUNGARY.

## QUANTITY AND VALUE OF ASPHALT PRODUCED.

Year.	Quantity.	Value.	Year.	Quantity.	Value.
	Metric Tons.	£.		Metric Tons.	£.
1898	3,125	13,622	1906	4,111	17,902
1899	3,060	13,426	1907	3,920	16,319
1900	2,900	12,698	1908	4,819	20,060
1901	2,878	12,573	1909	5,054	21,044
1902	2,774	12,173	1910	4,994	20,747
1903	2,422	10,603	1911	3,861	22,014
1904	2,221	9,492	1912	4,460	28,117
1905	173	791	1913	3,024	..

The value has been converted into £ sterling at the rate of 24.02 kronen=£1.

ITALY.

QUANTITY AND VALUE OF ASPHALT, ETC., PRODUCED.

Year.	Quantity.	Value.	Year.	Quantity.	Value.
	Metric Tons.	£.		Metric Tons.	£.
1900	100,775	53,595	1910	162,699	93,067
1901	104,111	52,352	1911	188,681	122,601
1902	64,245	30,366	1912	181,946	120,494
1903	89,690	49,333	1913	171,097	..
1904	111,900	63,829	1914	119,853	..
1905	107,014	61,255	1915	47,650	..
1906	131,339	71,905	1916	16,829	..
1907	161,640	90,828	1917	8,645	..
1908	134,694	75,682	1918	22,309	..
1909	111,538	62,706			

The value has been converted into £ sterling at the rate of 25 lire=£1.

JAPAN.

QUANTITY AND VALUE OF ASPHALT PRODUCED.

Year.	Quantity.	Value.	Year.	Quantity.	Value.
	Metric Tons.	£.		Metric Tons.	£.
1900	Not stated.	..	1907	584	1,117
1901	Not stated.	..	1908	2,404	5,253
1902	Not stated.	..	1909	4,186	9,289
1903	357	97	1910	477	5,960
1904	544	145	1911	1,260	2,821
1905	103	197	1912	2,906	6,682
1906	39	734			

MEXICO.

QUANTITY AND VALUE OF ASPHALT EXPORTED FROM MEXICO.

Year.	Quantity.	Value.	Year.	Quantity.	Value.
	Metric Tons.	£.		Metric Tons.	£.
1898	42	138	1906	1,389	3,529
1899	56	162	1907	4,486	37,453
1900	627	1,284	1908	5,272	67,996
1901	634	1,341	1909	5,471	21,881
1902	134	521	1910	2,849	8,154
1903	175	721	1911	8,805	25,752
1904	92	1,331	1912	30,492	94,982
1905	859	1,851			

The value has been converted into £ sterling at the rate of 10 dollars=£1.

## UNITED STATES OF AMERICA.

## QUANTITY AND VALUE OF ASPHALT PRODUCED.

Year.	Quantity.	Value.	Year.	Quantity.	Value.
	Metric Tons.	£.		Metric Tons.	£.
1898	69,252	139,309	1909	189,291	398,003
1899	68,135	114,207	1910	235,943	632,457
1900	49,355	85,764	1911	330,460	819,530
1901	57,290	114,502	1912	407,793	948,815
1902	95,671	157,742	1913	480,078	1,086,907
1903	91,831	207,308	1914	399,683	752,899
1904	74,002	186,338	1915	671,554	1,078,616
1905	104,570	155,678	1916	713,789	1,461,344
1906	125,246	264,957	1917	710,072	1,742,925
1907	203,085	580,388	1918	533,075	1,690,537
1908	168,177	387,861			

## RUSSIA.

## QUANTITY OF ASPHALT AND MINERAL PITCH PRODUCED.

Year.	Metric Tons.	Year.	Metric Tons.
1897, . . . . .	22,222	1904, . . . . .	Not stated.
1898, . . . . .	12,992	1905, . . . . .	21,221
1899, . . . . .	..	1906, . . . . .	11,135
1900, . . . . .	25,090	1907, . . . . .	12,809
1901, . . . . .	26,622	1908, . . . . .	22,033
1902, . . . . .	12,360	1909, . . . . .	57
1903, . . . . .	25,577	1910, . . . . .	23,924

## SPAIN.

## PRODUCTION OF ASPHALT (ROCK).

Year.	Quantity.	Year.	Quantity.
	Metric Tons.		Metric Tons.
1898, . . . . .	2,383	1909, . . . . .	5,283
1899, . . . . .	2,542	1910, . . . . .	7,795
1900, . . . . .	4,193	1911, . . . . .	3,741
1901, . . . . .	3,956	1912, . . . . .	5,387
1902, . . . . .	6,301	1913, . . . . .	5,582
1903, . . . . .	6,277	1914, . . . . .	5,765
1904, . . . . .	3,761	1915, . . . . .	4,521
1905, . . . . .	5,725	1916, . . . . .	7,316
1906, . . . . .	7,794	1917, . . . . .	..
1907, . . . . .	8,219	1918, . . . . .	8,395
1908, . . . . .	12,373		

## SWITZERLAND.

No figures of output relating to bituminous limestone, the asphalt rock of the Val de Travers, are available.



TRINIDAD.

QUANTITY AND VALUE OF ASPHALT EXPORTED FROM TRINIDAD.

	1899.	£.	1900.	£.
Liquid asphalt, . . . . .	4,270 gallons	49	2,052 gallons	1,381
Purified " . . . . .	14,483 tons	29,609	16,847 tons	33,695
Raw " . . . . .	122,097 "	122,406	141,905 "	142,384
Dried " . . . . .	780 "	1,089	..	..
		153,153		177,460

	a1901-2.	£.	a1902-3.	£.	a1903-4.	£.
Liquid asphalt, . . . . .	20,492 gallons	169	..	..	..	..
Purified " . . . . .	15,648 tons	31,296	11,427 tons	22,854	9,866 tons	19,732
Raw " . . . . .	127,747 "	127,748	145,712 "	145,712	178,984 "	178,984
Dried " . . . . .	589 "	589	1,997 "	1,997	2,585 "	3,446
		159,802		170,563		202,162

QUANTITY IN STATUTE TONS AND VALUE OF ASPHALT PRODUCED.

	1903.	£.	1904.	£.	1905.	£.	1906.	£.
Asphalt, raw . . . . .	169,813	169,813	118,432	118,432	78,518	78,518	100,800	100,800
" purified . . . . .	10,045	20,090	10,887	21,774	14,815	29,630	27,171	54,342
" dried . . . . .	2,484	3,312	3,722	4,962	7,245	9,660	4,446	5,928
Manjak . . . . .	587	880	3,023	4,534	1,077	1,615	1,112	2,273

	1907.	£.	1908.	£.	a1909-10.	£.
Asphalt, raw . . . . .	119,471	119,471	125,994	75,012	141,924	86,928
" purified . . . . .	24,246	32,328				
" dried . . . . .	6,451	8,064				
Manjak . . . . .	2,114	4,228	1,790	3,500	2,395	4,990

	a1910-11.	£.	a1911-12.	£.	a1912-13.	£.
Asphalt, raw . . . . .	138,244	81,311	184,753	93,772	210,047	109,063
" purified . . . . .						
" dried . . . . .						
Manjak . . . . .	1,910	3,979	1,570	3,345	1,251	2,606

a Year ended 31st March.

## QUANTITY, IN LONG TONS, OF ASPHALT EXPORTED.

	To U.S.A.	To Europe.	To Other Countries.	Total.
1911, . . . .	111,630	67,105	983	179,718
1912, . . . .	103,711	85,299	486	189,496
1913, . . . .	125,273	104,153	605	230,031
1914, . . . .	70,307	75,297	..	145,604
1915, . . . .	119,251	18,025	..	136,026
1916, . . . .	117,719	13,380	..	131,099
1917, . . . .	119,149	11,496	..	130,645
1918, . . . .	58,528	14,552	..	73,080

## TURKEY.

## QUANTITY AND VALUE OF ASPHALT PRODUCED.

Year.	Quantity.	Value.
	Tons.	£.
1901, . . . .	3,500	..
1902, . . . .	Not stated.	..
1903, . . . .	Not stated.	..
1904, . . . .	4,700	£5 to £20 per ton.
1905, . . . .	Not stated.	..
1906, . . . .	Not stated.	..
1907, . . . .	Not stated.	..
1908, . . . .	a 5,267 metric tons.	11,875
1909, . . . .	a 6,039 metric tons.	15,000

a For the year ended March.

## VENEZUELA.

In 1899, 79 metric tons of asphalt was exported from Maracaibo; and in 1902, 4049 metric tons, valued at £15,543. No figures are obtainable for the years 1900 and 1901. The quantity exported in 1903 amounted to 14,567 metric tons, valued at £58,871.

## EXPORTS OF ASPHALT FROM VENEZUELA.

Year. <sup>a</sup>	Quantity.	Value.	Year. <sup>a</sup>	Quantity.	Value.
	Metric Tons.	£.		Metric Tons.	£.
1904	36,225	96,063	1912	56,514	62,670
1905	30,675	52,613	1913	61,113	69,645
1906	20,080	19,990	1914	45,306	..
1907	34,153	35,534	1915	28,983	..
1908	40,774	42,065	1916	44,612	..
1909	..	..	1917	49,360	..
1910	33,840	37,000	1918	42,923	..
1911	36,627	39,270			

<sup>a</sup> Year ended 30th June.

The value has been converted into £ sterling at the rate of 25.25 bolivares=£1.

## OIL SHALE.

## UNITED KINGDOM.

## OUTPUT AND VALUE OF OIL SHALE IN THE UNITED KINGDOM FROM THE YEAR 1873 TO 1919.

Year.	Quantity.	Value.	Year.	Quantity.	Value.
	Tons.	£.		Tons.	£.
1873	524,095	262,047	1897	2,223,745	555,936
1874	362,747	181,373	1898	2,137,993	534,498
1875	437,774	218,887	1899	2,210,824	553,003
1876	603,538	301,769	1900	2,282,221	627,844
1877	801,701	400,850	1901	2,354,356	589,162
1878	788,704	394,352	1902	2,107,534	500,804
1879	783,748	391,824	1903	2,009,602	477,312
1880	837,805	418,902	1904	2,333,062	544,346
1881	958,255	479,127	1905	2,496,785	593,334
1882	1,030,915	310,685	1906	2,546,522	657,928
1883	1,167,943	299,676	1907	2,690,028	806,323
1884	1,518,871	386,780	1908	2,892,039	795,257
1885	1,770,413	447,302	1909	2,967,057	815,937
1886	1,728,503	435,963	1910	3,130,280	860,827
1887	1,411,378	355,085	1911	3,116,803	857,120
1888	2,076,469	519,074	1912	3,184,826	765,730
1889	2,014,860	503,715	1913	3,280,143	822,394
1890	2,212,250	608,369	1914	3,268,666	837,249
1891	2,361,119	707,177	1915	2,998,652	836,593
1892	2,089,937	522,484	1916	3,009,232	1,032,294
1893	1,956,520	489,130	1917	3,117,658	1,280,007
1894	1,986,385	496,596	1918	3,080,867	1,528,584
1895	2,246,865	561,716	1919	2,763,875	1,567,050
1896	2,419,525	604,881			

## QUANTITY AND VALUE OF OIL SHALE RAISED IN GREAT BRITAIN, 1900 TO 1910.

County.	1900.		1901.		1902.		1903.		1904.	
	Tons.	£.	Tons.	£.	Tons.	£.	Tons.	£.	Tons.	£.
Stafford, . . . . .	2,342	878	388	97	1,581	593	193	58	1,177	441
Flint, . . . . .	1,315	499	3,691	1,384	1,104	276	144	54	..	..
Ayr, . . . . .	637,810	175,398	665,399	166,350	647,432	153,765	583,309	138,536	611,477	145,226
Edinburgh, . . . . .	51,585	14,186	31,802	7,989	49,474	11,783	12,683	3,012	7,586	1,872
Leamark, . . . . .	1,586,753	436,357	1,648,447	412,112	1,407,695	334,328	1,413,145	335,622	1,712,631	406,750
Linlithgow, . . . . .	38	10	446	123	..	..	..	..	..	..
Renfrew, . . . . .	1,878	510	2,049	572	142	34	128	30	50	15
Stirling, . . . . .	..	..	79	20	106	25	..	..	141	42
Sutherland, . . . . .	..	..	..	..	..	..	..	..	..	..
Total, . . . . .	2,282,221	627,844	2,354,356	589,162	2,107,534	500,804	2,009,602	477,312	2,333,062	554,346

County.	1905.		1906.		1907.		1908.		1909.		1910.	
	Tons.	£.	Tons.	£.	Tons.	£.	Tons.	£.	Tons.	£.	Tons.	£.
Stafford, . . . . .	2,000	600	..	..	..	..	..	..	40	7	..	..
Flint, . . . . .	1,704	596	798	279	..	..	..	..	..	..	..	..
Ayr, . . . . .	669,571	169,023	732,635	189,264	796,569	238,971	811,577	223,184	639,035	175,735	728,058	200,216
Edinburgh, . . . . .	17,861	4,242	21,051	5,438	18,639	5,592	44,739	12,303	66,753	18,357	84,060 <sup>a</sup>	23,116
Leamark, . . . . .	1,805,497	428,829	1,791,896	462,906	1,874,671	561,700	2,085,723	559,770	2,291,086	621,799	2,318,162	637,495
Linlithgow, . . . . .	..	..	..	..	..	..	..	..	..	..	..	..
Renfrew, . . . . .	..	..	..	..	..	..	..	..	..	..	..	..
Stirling, . . . . .	..	..	142	41	149	60	..	..	143	39	..	..
Sutherland, . . . . .	152	44	..	..	..	..	..	..	..	..	..	..
Total, . . . . .	2,496,785	593,334	2,546,522	657,928	2,690,028	806,323	2,892,039	795,257	2,967,057	815,937	3,130,280	860,827

<sup>a</sup> Includes the production in Sutherland.

## QUANTITY AND VALUE OF OIL SHALE RAISED IN GREAT BRITAIN, 1911 TO 1919.

County.	1911.		1912.		1913.		1914.	
	Tons.	£.	Tons.	£.	Tons.	£.	Tons.	£.
Stafford, . . . . .	..	..	..	..	..	..	..	..
Dorset, . . . . .	..	..	..	..	..	..	..	..
Flint, . . . . .	..	..	..	..	..	..	..	..
AYT, . . . . .	..	..	240	70	..	..	231	58
Edinburgh, . . . . .	709,906	195,224	..	..	723,766	..	781,233	..
Lanark, . . . . .	93,514	25,716	718,934	765,730	61,408	..	60,626	..
Linlithgow, . . . . .	2,313,383	636,180	80,574	..	2,494,658	822,324	2,426,286	837,191
Renfrew, . . . . .	..	..	2,385,318	..	..	..	..	..
Stirling, . . . . .	..	..	..	..	..	..	..	..
Sutherland, . . . . .	..	..	..	..	..	..	..	..
Fife, . . . . .	..	..	..	..	..	..	..	..
Total, . . . . .	3,116,803	857,120	3,184,826	765,730	3,280,143	822,394	3,268,666	837,249

County.	1915.		1916.		1917.		1918.		1919.	
	Tons.	£.	Tons.	£.	Tons.	£.	Tons.	£.	Tons.	£.
Stafford, . . . . .	5,976	1,393	..	..	329	207	40	25	..	..
Dorset, . . . . .	..	..	..	..	800	800	450	450	..	..
Flint, . . . . .	..	..	..	..	..	..	..	..	..	..
AYT, . . . . .	..	..	..	..	..	..	..	..	..	..
Edinburgh, . . . . .	658,655	..	667,185	..	682	..	646,416	..	..	..
Lanark, . . . . .	..	..	..	..	690,214	..	..	..	..	..
Linlithgow, . . . . .	2,333,622	835,200	2,341,903	1,032,294	2,425,431	..	2,433,901	1,528,078	580,910	1,567,050
Renfrew, . . . . .	..	..	..	..	..	1,279,000	..	..	..	..
Stirling, . . . . .	399	..	144	..	159	..	..	..	..	..
Sutherland, . . . . .	..	..	..	..	..	..	..	..	..	..
Fife, . . . . .	..	..	..	..	..	..	..	..	..	..
Total, . . . . .	2,998,652	836,593	3,009,232	1,032,294	3,117,658	1,280,007	53,080,867	6 1,528,584	2,763,875	1,567,050

<sup>a</sup> Including 4,017 tons from quarries.

<sup>b</sup> Including 10 tons from Gloucester, valued at £6, and 50 tons from Shropshire, valued at £25.

<sup>c</sup> Includes 600 tons from Norfolk.

## FRANCE.

## QUANTITY AND VALUE OF BITUMINOUS SHALE, LIMESTONE, ETC., PRODUCED.

Year.	Quantity.	Value.	Year.	Quantity.	Value.
	Metric Tons.	£.		Metric Tons.	£.
1900	266,474	76,686	1907	177,074	65,769
1901	249,655	74,598	1908	171,158	54,287
1902	258,295	80,882	1909	169,054	55,309
1903	243,295	72,528	1910	169,769	56,963
1904	227,177	66,197	1911	169,697	54,248
1905	191,509	66,853	1912	611,848	81,657
1906	196,375	71,016			

The value has been converted into £ sterling at the rate of 25 francs=£1.

## NEW SOUTH WALES.

## KEROSENE SHALE PRODUCED IN NEW SOUTH WALES FROM 1865 TO 1918.

Year.	Quantity.	Average Price per Ton.	Total Value.	Year.	Quantity.	Average Price per Ton.	Total Value.
	Tons.	£ s. d.	£ s. d.		Tons.	£ s. d.	£ s. d.
1865	570	4 2 5-47	2,350 0 0	1893	55,660	1 16 4	101,220 0 0
1866	2,770	2 18 10-48	8,150 0 0	1894	21,171	1 10 0	31,781 0 0
1867	4,079	3 14 9-21	15,249 0 0	1895	59,426	1 5 4	75,219 0 0
1868	16,952	2 17 7-11	48,816 0 0	1896	31,839	1 1 6	34,202 0 0
1869	7,500	2 10 0-00	18,750 0 0	1897	34,090	1 3 9	40,612 0 0
1870	8,580	3 4 3-18	27,570 0 0	1898	29,689	1 1 5	31,834 0 0
1871	14,700	2 6 3-91	34,050 0 0	1899	36,719	1 2 3	40,823 0 0
1872	11,040	2 11 11-91	28,700 0 0	1900	22,862	18 1	20,652 0 0
1873	17,850	2 16 6-55	50,475 0 0	1901	54,774	15 2	41,489 0 0
1874	12,100	2 5 1-48	27,300 0 0	1902	62,880	19 0	59,717 0 0
1875	6,197	2 10 2-22	15,000 0 0	1903	34,776	14 9	28,617 0 0
1876	15,998	3 0 0-00	47,994 0 0	1904	37,871	14 1-63	26,770 0 0
1877	18,963	2 9 0-81	46,524 0 0	1905	38,226	11 1-39	21,247 0 0
1878	24,371	2 6 11-40	57,211 0 0	1906	32,446	17 6-57	28,470 0 0
1879	32,519	2 1 1-96	66,930 10 0	1907	47,331	13 6-52	32,055 0 0
1880	19,201	2 6 7-03	44,724 15 0	1908	46,303	11 3-09	26,067 0 0
1881	27,894	1 9 2-59	40,748 0 0	1909	48,718	9 8-32	23,617 0 0
1882	48,065	1 15 0-00	84,114 0 0	1910	68,293	9 11-12	33,896 0 0
1883	49,250	1 16 10-77	90,861 10 0	1911	75,104	9 10-17	36,980 0 0
1884	31,618	2 5 7-86	72,176 0 0	1912	<sup>a</sup> 86,018	8 1-01	34,770 0 0
1885	27,462	2 8 11-62	67,239 0 0	1913	<sup>a</sup> 16,985	8 9-14	7,349 0 0
1886	43,563	2 5 10-79	99,976 0 0	1914	50,049	10 9-03	27,408 0 0
1887	40,010	2 3 10-43	87,761 0 0	1915	15,474	16 8-18	12,907 0 0
1888	34,869	2 2 2-66	73,612 0 0	1916	17,425	1 0 5-11	17,796 0 0
1889	40,561	1 18 3-55	77,666 15 0	1917	31,661	1 3 1-53	36,613 0 0
1890	56,010	1 17 2	104,103 0 0	1918	32,395	1 4 6-33	39,729 0 0
1891	40,349	1 18 9	78,160 0 0	1919	25,954	..	..
1892	74,197	1 16 8	136,079 0 0				

<sup>a</sup> Estimated.

## NEW ZEALAND.

## OUTPUT AND VALUE OF OIL SHALE IN NEW ZEALAND.

Year.	Quantity in Tons.	Value in £.
1901, . . .	12,048	6,024
1902, . . .	2,338	1,169
1903, . . .	36	18
1904, . . .	Nil.	..
1905, . . .	Nil.	..
1906, . . .	Nil.	..
1907, . . .	Nil.	..
1908, . . .	1	4
1909, . . .	Nil.	..

## SPAIN.

Oil shale is mined in Spain, but no statistical data are obtainable as to the quantity raised.

## APPENDIX B.

IMPORT DUTIES LEVIED ON PETROLEUM.<sup>1</sup>

*Schedule of duties charged on petroleum and products of petroleum when imported into the following foreign countries:—*

## ABYSSINIA.

(See Ethiopia.)

## ALGERIA.

Same as France, with local sea tax (*octroi de mer*) of 5 francs per 100 kilograms.

## ANTIGUA.

Oil to be used as fuel in oil engines, free.

Petroleum, 2s. per case of 8 imperial gallons; in wood, 3d. per gallon.

Paraffin candles, 3d. per pound.

Other products, £13, 6s. 8d. per £100.

## ARGENTINE REPUBLIC.

Crude petroleum, naphtha, and carburine, free.

“Ligroin” and similar products, and natural benzines with a boiling-point below 120° C., 25 per cent. on a valuation of 10 centavos per kilogram.

Benzine, rectified, 25 per cent. on a valuation of 30 centavos per kilogram, net.

Mineral oil not specially mentioned, 25 per cent. on a valuation of 10 centavos per kilogram.

Mineral oil in flasks, 25 per cent. on a valuation of 75 centavos per kilogram.

Paraffin oils, impure, 25 per cent. on a valuation of 20 centavos per kilogram.

Petroleum residues, impure, 25 per cent. on a valuation of 3 centavos per kilogram, gross.

Paraffin of all kinds, 25 per cent. on a valuation of 30 centavos per kilogram.

Paraffin candles, 10 centavos per kilogram.

Kerosene, 3 centavos per litre.

Vaseline, yellow or petrolate, 25 per cent. on a valuation of 20 centavos per kilogram; in flasks, boxes, or pots, antiseptic or not, of any trade mark, 25 per cent. on a valuation of 60 centavos per kilogram.

Vaseline, white or aboline, 25 per cent. on a valuation of 40 centavos per kilogram; in flasks, boxes, or pots, antiseptic or not, including creams and cold creams of any trade mark, 25 per cent. on a valuation of 70 centavos per kilogram.

Heavy tar oils, including phenol, 5 per cent. on a valuation of 2 centavos per kilogram.

Mineral tar, 10 per cent. on a valuation of 2 centavos per kilogram.

Asphalt or Trinidad bitumen for macadamising, 5 per cent. on a valuation of 4 centavos per kilogram.

Natural asphalt rock, 5 per cent. on a valuation of 8 centavos per 10 kilograms.

Asphalt or Jew's pitch, Barbados or other bitumen, 25 per cent. on a valuation of 20 centavos per kilogram.

Mineral pitch, 10 per cent. on a valuation of 1 centavo per kilogram, gross.

<sup>1</sup> From Kelly's *Customs Tariffs of the World*, 1921.



## ARUBA.

Crude petroleum and petroleum residues, free.

Petroleum, 80 cents per 100 litres.

## AUSTRALIAN COMMONWEALTH.

Candles, 1½d. per pound.

Kerosene and crude petroleum, free.

Naphtha, benzine, benzoline, gasoline, pentane, petrol, and other petroleum or shale spirit, ½d. per gallon.

Lubricating (mineral) and all other mineral oils, 3d. per gallon.

Paraffin wax, 1d. per pound.

Wax, dentist or modelling, free.

Asphalt mastic, 15 per cent. *ad valorem*.

## AUSTRIA.

Petroleum, crude, not fit for illuminating purposes without previous refinement combined with distillation, 8-30 kronen per 100 kilograms.

Petroleum, crude, capable of being used for lighting without previous refinement combined with distillation, 11 kronen per 100 kilograms.

Petroleum, refined or half-refined, of light weight, the density of which amounts to 0-880 or less, 11 kronen per 100 kilograms.

Refined or half-refined mineral oils, heavy, the density of which exceeds 0-880, yellow and reddish yellow, further lubricating oils, also mixed with animal or vegetable oils or fat, 12 kronen per 100 kilograms; heavy, the density of which exceeds 0-880, dark, 7 kronen per 100 kilograms.

Distillates of heavy oils fit as raw material for lubricating oil factories, when intended for mineral oil refineries of the country, 7 kronen per 100 kilograms; residues of the distillation of mineral oils or of purification, same. Above, all net weight.

Paraffin, 16 kronen per 100 kilograms.

Paraffin candles, 28 kronen per 100 kilograms.

Ceresin, 10 kronen per 100 kilograms.

## BAHAMAS.

Naphtha, gasoline, crude petroleum, and petrol, free.

Crude vaseline, 10 per cent. *ad valorem*.

Kerosene oil, 3d. per gallon. (A drawback of 90 per cent. of the Customs duties is allowed upon all kerosene oil used as fuel in the working of steam, oil, or gas engines.)

## BARBADOS.

Kerosene, 4d. per gallon.

Candles, other than tallow, 8s. 4d. per 100 pounds.

Asphalt, free.

## BELGIUM.

Petroleum and its products, free.

## BERMUDA.

Kerosene oil, ¾d. per gallon.

Bunker oil, 3s. 0d. per ton.

## BOLIVIA.

Gasoline, naphtha, paraffin, petroleum, or kerosene, 30 per cent. on a valuation of 8 centavos per kilogram, gross weight.

Paraffin, in paste, 15 per cent. on a valuation of 25 centavos per kilogram, gross weight.

Benzine, common, 30 per cent. on a valuation of 12 centavos per kilogram, including packages.

Benzine, rectified, 30 per cent. on a valuation of 80 centavos per kilogram, including packages.

Vaseline, 30 per cent. on a valuation of 1 boliviana per kilogram, including packages.

Tar, liquid, 30 per cent. on a valuation of 65 centavos per kilogram, including packages.

## BONAIRE.

Petroleum, 80 cents per 100 litres.

Crude petroleum and petroleum residues, free.

## BRAZIL.

Crude petroleum, 50 per cent. on a valuation of 10 reis per kilogram.

Naphtha, 50 per cent. on a valuation of 150 reis per kilogram.

Illuminating oil and gasoline, 60 per cent. on a valuation of 40 reis per kilogram.

Lubricating oil and petroleum residues, 50 per cent. on a valuation of 40 reis per kilogram.

## BRITISH CENTRAL AFRICA PROTECTORATE.

Petroleum and its products, 10 per cent. *ad valorem*.

## BRITISH EAST AFRICA PROTECTORATE.

Petroleum and its products, 10 per cent. *ad valorem*.

## BRITISH GUIANA.

Oil (other than gasoline, benzine, naphtha, and crude petroleum) vapour inflammable at less than 85° F., 12½ cents per gallon.

Crude petroleum, including residual oils, 25 cents per 100 gallons.

Oils, all other, including gasoline, naphtha, and benzine, 5 cents per gallon.

Oil fuel, including gas oil and intermediate oils, 50 cents per 100 gallons. If for storage in tanks, 38 cents per 100 gallons.

Paraffin candles, 5 cents per pound.

Grease, antifriction, axle grease, and similar compounds, 2 cents per pound.

Tar, 50 cents per barrel not exceeding 200 pounds.

All above rates are subject to an additional duty of 5 per cent.

## BRITISH HONDURAS.

Illuminating oil, including kerosene and other refined burning oils, 1 cent per gallon.

Lubricating oil, free.

Motor spirit, including benzine, benzoline, gasoline, naphtha, and petrol spirits generally, free.

Oil fuel, free.

- Oil, mineral, other than petroleum, 10 cents per gallon.  
 Paraffin candles, 10 per cent. *ad valorem*.  
 Asphalt, including pitch and tar, 5 per cent. *ad valorem*.  
 Other articles of petroleum origin, 10 per cent. *ad valorem*.

## BRITISH INDIA.

Petroleum, including also naphtha and the liquids commonly known by the names of rock oil, Rangoon oil, Burma oil, kerosene, paraffin oil, mineral oil, petrol, gasoline, benzol, benzoline, benzine, and any inflammable liquid which is made from petroleum, coal, schist, shale, peat, or any other bituminous substance, or from any products of petroleum, 1 anna 6 pies per imperial gallon.

Petroleum which has its flashing-point at or above 200° F. and is proved to the satisfaction of the Customs collector to be intended for use exclusively for the batching of jute or other fibre, or for lubricating purposes, 11 per cent. *ad valorem*.

Petroleum which has its flashing-point at or above 150° F. and is proved to the satisfaction of the Customs collector to be intended for use exclusively as fuel, 11 per cent. *ad valorem*.

Motor spirit is liable to an additional duty of 6 annas per imperial gallon.

All other sorts of mineral oil and paraffin wax, 11 per cent. *ad valorem*.

Mineral tar, 11 per cent. *ad valorem*.

## BRITISH NORTH BORNEO.

Kerosene, 40 cents per case of 65 pounds.

Other oils used for burning, 30 cents per case of 100 pounds.

## CAMEROONS.

Petroleum and its products, 10 per cent. *ad valorem*.

## CANADA.

Paraffin wax, 15 per cent. *ad valorem*.

Illuminating oils composed wholly or in part of the products of petroleum, coal, shale, or lignite, costing more than 30 cents per gallon, 15 per cent. *ad valorem*.

Lubricating oils composed wholly or in part of petroleum, costing less than 25 cents per gallon, 1½ cents per gallon.

Crude petroleum, gas oils (other than naphtha, benzine, and gasoline), lighter than 0.8235, but not less than 0.775 specific gravity, at 60° F., 1 cent per gallon.

Oils, coal and kerosene, distilled, purified, or refined naphtha and petroleum, and products of petroleum, not elsewhere specified, 1½ cents per gallon.

Coal pitch and tar in packages of not less than 15 gallons, free.

Asphalt, free.

Lubricating oils, not elsewhere specified, and axle grease, 12½ per cent. *ad valorem*.

Vaseline, and all similar preparations of petroleum for toilet, medicinal, or other purposes, 15 per cent. *ad valorem*.

Oils (petroleum), when imported by miners or mining companies or concerns, to be used in the concentration of ores of metal in their own concentrating establishments, under such regulations as the Minister of Customs may prescribe, free.

## CAPE VERDE ISLANDS.

Petroleum, 20 reis per kilogram.

Products of petroleum, 20 per cent. *ad valorem*.

Paraffin candles, 70 reis per kilogram.

## CEYLON.

Liquid fuel, the product of petroleum, with a flashing-point not under 150° F., Abel's close test, free.

Kerosene, including the liquids commonly known by the names of rock oil, Rangoon oil, Burma oil, kerosene, petroleum, paraffin oil, mineral oil, petroline, gasoline, benzol, benzoline, benzine; also any liquid that is made from petroleum, coal, schist, shale, peat, or any other bituminous substance, or from any products of petroleum with a flashing-point of less than 150° F., 30 cents per gallon. (A rebate equivalent to the duty is allowed on kerosene oil if to be used as a source of motive power in oil engines.)

## CHILE.

Benzine, common, 2 centavos per kilogram, gross.

Benzine, rectified, 30 centavos per kilogram, legal.

Paraffin candles, for night lights, 35 centavos per kilogram, legal.

Paraffin candles, with gilding or ornaments, 80 centavos per kilogram, legal.

3 centavos per kilogram, legal.

Tapers and candles of wax or combined with wax, white or coloured, 80 centavos per kilogram, legal.

Candles of wax or combined with wax, with gilding or ornaments, 2 pesos per kilogram, legal.

Paraffin in the mass, 5 centavos per kilogram, gross.

Paraffin, petroleum, gasoline, naphtha, or kerosene for illuminating purposes, 3 pesos per 100 kilograms, gross.

Crude petroleum, free.

Vaseline or vaseline cream for the complexion, 30 centavos per kilogram, gross.

Tar or mineral pitch, 1 centavo per kilogram, gross.

## CHINA.

Kerosene, in cases of 10 American gallons, 0.11 H.K. tael per case; in bulk, 0.08 H.K. tael per 10 American gallons.

Liquid fuel, 0.73 H.K. tael on a valuation of 14.572 H.K. taels per ton.

Lubricating oil, 0.015 H.K. tael per American gallon.

Vaseline, 5 per cent. *ad valorem*.

Paraffin wax, 5 H.K. taels per picul.

All other products, 5 per cent. *ad valorem*.

## COLOMBIA.

Crude petroleum, and other mineral oils of greater density, not manufactured, 2 centavos gold per kilogram.

Petroleum, refined, for lighting, 8 centavos gold per kilogram.

Paraffin, manufactured into candles, 12 centavos gold per kilogram.

Benzine, 3 centavos gold per kilogram.

Gasoline, and fuel oil, 1 centavo gold per kilogram.

Vaseline, 20 centavos gold per kilogram.

Paraffin, unmanufactured, 2 centavos gold per kilogram.

Tar, 3 centavos gold per kilogram.

## COMORO ISLANDS.

Petroleum, 3 francs per 100 kilograms.

## COSTA RICA.

Crude petroleum, free.

Refined petroleum, 20 centimes of a colon per kilogram, gross weight, plus surtax of 52 per cent.

Mineral tar, 5 centavos per kilogram, gross weight, plus surtax of 52 per cent.

Mineral wax, 40 centimes per kilogram, gross weight.

## CUBA.

Crude oils derived from schists, including crude petroleum, axle grease for cars and carts, \$1.75 per 100 kilograms, gross.

Crude petroleum to be used exclusively in the manufacture of illuminating gas and only at gas works in Cuba, \$0.70 per 100 kilograms, gross.

Cordage oil, \$0.70 per 100 kilograms, gross.

Petroleum and other mineral oils, rectified or refined, intended for illumination, \$4.375 per 100 kilograms, gross.

Benzine, gasoline, and mineral oils, not specially mentioned, including vaseline, \$4.70 per 100 kilograms, gross.

Mineral wax unwrought, and paraffin in lumps, \$2.50 per 100 kilograms, gross.

Articles of paraffin and wax of all kinds, wrought, \$5.00 per 100 kilograms, tare.

Tar and mineral pitch, \$0.60 per 100 kilograms, gross.

Refined lubricating oils, and crude shale and petroleum lubricating oils, \$3.50 per 100 kilograms, gross.

## CURAÇAO.

Crude petroleum and petroleum residues, free.

Petroleum, 80 cents per 100 litres.

Other oils, 3 per cent. *ad valorem*.

## CYPRUS.

Petroleum, in cases not exceeding 25 okes each, net weight, 1s. per case.

Petroleum, in cases exceeding 25 okes each, net weight, and in barrels, 1½ copper piastres per gallon.

Petrol, benzine, and crude oil, when imported as fuel for oil engines, free.

## DENMARK.

Rock oil, including petroleum (both raw and for lighting); petroleum benzine; waste of rock oil and other residual products of distillation similar to tar or asphalt, provided that they are heavier than water; burning fuel for use in motors, etc., with a flash-point below 150° C. and a viscosity of under 2.6 at 20° C., free.

Residuum oils and tar, provided they are not translucent when held in a 1-centimetre test-tube against the flame of a candle, with a flash-point as declared and tested of over 90° C., but under 200° C., in the open apparatus, free.

Volatile and oleaginous products of the distillation of rock oils, tar and resin

oils, *e.g.* benzol (coal naphtha) and the like, with flash-point below 40° C. in open apparatus, 4 öre per kilogram.

Pitch, mineral tar, and asphalt, free.

#### DOMINICA.

Crude petroleum, or petroleum residue, giving off an inflammable vapour at a temperature not less than 150° F., 1s. 8d. per 240 gallons.

#### DOMINICAN REPUBLIC.

Refined or rectified oils, such as petroleum, kerosene, "gas," paraffin oil, benzine, and similar products, \$10.56 per 1000 litres.

Gasoline and naphtha, \$7.92 per 1000 litres.

Paraffin candles, 8 cents per kilogram gross.

All other products, and crude petroleum, free.

#### DUTCH EAST INDIES.

Petroleum, 40 cents (Dutch) per hectolitre.

#### DUTCH GUIANA.

Kerosene, oleine, photogen, tar, and other mineral and petroleum oils, 5 cents (Dutch) per litre.

Asphalt, crude kerosene and kerosene residues, crude mineral oils and residues thereof fit only for the manufacture of illuminating oils in the Colony and which cannot be used for lubricating, pitch and tar, free.

#### ECUADOR.

Gasoline, 2½ centavos per kilogram.

Paraffin candles, 22½ centavos per kilogram.

Grease, machine, 4½ centavos per kilogram.

Grease, impure, 4½ centavos per kilogram.

Kerosene, of 150° strength and above, 11½ centavos per kilogram; under 150° prohibited.

Oil, machine, 11½ centavos per kilogram.

Paraffin, 4½ centavos per kilogram.

Tar, 11½ centavos per kilogram.

Crude petroleum, 11½ centavos per kilogram.

All the above gross weight.

#### EGYPT.

Petroleum and its products, 8 per cent. *ad valorem*.

#### ERYTHREA (MASSOWAH).

Oils, fixed, mineral, or volatile, 15 per cent. *ad valorem*.

Products, 8 per cent. *ad valorem*.

#### ETHIOPIA.

(Abyssinia.)

Candles, one-half piastre per package.

Petroleum, 8 piastres per case of 36 litres.

Mineral essence, 6 piastres per case of 36 litres

Oil, 12 piastres per 18 litres.

## FALKLAND ISLANDS.

Petroleum, rock oil, and wax, all kinds, free.

## FAROE ISLANDS.

Petroleum and its products, free.

## FIJI ISLANDS.

Benzine, benzoline, gasoline, naphtha, and other liquid products of petroleum not otherwise enumerated, and crude petroleum, 2d. per gallon.

Kerosene of 100° or over, closed flash test, 6d. per gallon; under 100°, closed flash test, 8d. per gallon.

Oil, lubricating, being the product of petroleum, 9d. per gallon.

Vaseline, or soft paraffin, 2d. per pound.

Tar, free.

## FINLAND.

Mineral oil, natural, raw, as rock oil (naphtha), etc., free.

Petrol, 6 penni per kilogram.

Petrol-benzine, gasoline, "ligroin," polishing oil, lubricating oil, not specially named, paraffin, raw or refined, ozokerite and ceresin, 24 penni per kilogram.

Vaseline, 36 penni per kilogram.

Asphalt and pitch, free.

## FRANCE.

Mineral oils suitable for lighting purposes, crude, 7.20 francs per hectolitre.

Mineral oils suitable for lighting purposes, refined or essence, 10 francs per hectolitre.

Heavy oils and residues of mineral oils, 9 francs per 100 kilograms, net.

Paraffin and paraffin candles, 30 francs per 100 kilograms, net.

Vaseline, 28 francs per 100 kilograms, net.

Coal tar, free.

Mineral wax or ozokerite, raw, 10 francs per 100 kilograms; refined, 40 francs per 100 kilograms.

Bitumen and asphalt, free.

## FRENCH CONGO.

(Gaboon.)

Mineral oils (schist), petroleum oils, and other mineral oils, 8 francs per hectolitre.

## FRENCH CONGO.

(West basin of the Congo.)

Petroleum and its products, 3 per cent. *ad valorem*.

## FRENCH GUIANA.

Petroleum and its products, free.

## FRENCH INDIES.

Petroleum and its products, free.

## FRENCH OCEANIA.

Schist oil, 0.85 franc per 30 kilograms.

Gasoline and petroleum suitable for fuel in machines for locomotion, navigation, and agricultural or industrial purposes, free.

Grease for carriages or harness, 7 francs per 100 kilograms.

Other products, 8 per cent. *ad valorem*.

## FRENCH SOMALI COAST.

Consumption duties :—Paraffin candles, 6 francs per 100 kilograms ; petroleum and other mineral oils for lighting, 5 francs per 100 kilograms ; wax, raw, free ; mineral oils, except for lighting, free.

## GAMBIA.

Petroleum, rock oil, kerosene, or paraffin oils, giving off an inflammable vapour at a temperature below 95° F., prohibited.

Kerosene and other burning oils, not being edible oils, 4d. per gallon.

Other products, 7½ per cent. *ad valorem*.

## GERMANY.

Petroleum, and other mineral oils not elsewhere mentioned, crude or refined, not including mineral oils for the purpose of lubrication, 6 marks per 100 kilograms.

Mineral oils for the purpose of lubrication, 10 marks per 100 kilograms (tare).

NOTES.—1. The Bundesrath is authorised to admit free of duty, under control, mineral oils intended for industrial purposes other than the manufacture of lubricating or lighting oil.

2. The Bundesrath is authorised to allow the payment of import duty on petroleum to be effected according to the number of barrels, after taking the maximum weight of the ordinary barrels employed in commerce.

3. The Bundesrath is authorised to admit free of duty, under control, mineral oil intended to be cleaned, refined, or distilled in national factories, so that the produce obtained therefrom, such as benzine, ligroin and petroleum ether, remain free of duty, on condition that they cannot be employed for lighting or lubrication, under control and by special permission, and on condition, further, that all other products shall be dutiable as foreign products.

Carriage grease, 10 marks per 100 kilograms.

Candles, 23 marks per 100 kilograms (tare).

Paraffin, 10 marks per 100 kilograms (tare).

Mineral wax, refined, 15 marks per 100 kilograms (tare).

Tar, free.

## GIBRALTAR.

Petroleum and rock oils, all kinds, free.

## GOLD COAST COLONY.

Illuminating oil, including kerosene and other refined petroleum burning oils, 6d. per gallon.

Motor spirit, including benzine, benzoline, gasoline, naphtha, and petrol spirits generally, 3d. per gallon.

Oil fuel, not being illuminating oil or motor spirit, free.



## GREECE.

Ceresin and paraffin, 250 drachmas per 100 okes.

Paraffin candles, 200 drachmas per 100 okes.

Mineral oils (except petroleum, the importation of which is prohibited as a Government monopoly) 72.50 drachmas per 100 okes.

## GRENADA.

Fuel oil, free.

Lubricating oil, 8d. per gallon.

Motor spirit, including benzine, benzoline, gasoline, naphtha, and petrol spirits generally, 4d. per gallon.

Kerosene and paraffin oils, 2d. per gallon.

All other oils, 8d. per gallon.

Paraffin candles, 13s. 4d. per 100 lbs.

## GUADELOUPE.

Petroleum, schist, and other mineral oils fit for lighting, crude, refined, and essences, 7.05 francs per hectolitre; sea-octroi tariff, 7.95 francs per hectolitre.

Heavy oil and residues of petroleum and of other mineral oils, 1 franc per hectolitre; sea-octroi tariff, 6 francs per 100 kilograms, net.

Paraffin and vaseline, sea-octroi tariff, 10 francs per 100 kilograms, net.

## GUATEMALA.

Mineral oil, crude, free.

Petroleum, refined, and gasoline, 5 centavos per kilogram, gross.

Lubricating oils, 10 centavos per kilogram, gross.

Benzine, 30 centavos per kilogram, gross.

Tar, free.

Wax, mineral or ceresin, and paraffin, in cakes, 10 centavos per kilogram, gross.

Paraffin wax candles, 25 centavos per kilogram, gross.

## GUERNSEY.

Petrol and lubricating oils, 1d. per gallon.

## HAITI.

Wax candles, 10 cents per pound.

Machine grease, 1 cent. per pound.

Petroleum (kerosene) at 38° C., or 100° F., 5 cents per gallon; below those degrees, prohibited.

Naphtha, prohibited.

Tar, 1 gourde per barrel.

Surtax of 25 per cent. on aggregate import duties, payable in gold.

## HONDURAS, REPUBLIC OF.

Petroleum, kerosene, gasoline, naphtha, and grease, 5 centavos per one-half kilogram.

Wax candles, 50 centavos per one-half kilogram.

Tar,  $\frac{1}{2}$  5 centavos per one-half kilogram.

All gross weight.

## HONG-KONG.

Petroleum, rock oil, and wax, all kinds, free.

## HUNGARY.

Vaseline and lanoline; petroleum pitch; bituminous earths; asphalt bitumen; asphalt mastic; paraffin candles, free.

Other products, special import duties.

## ICELAND.

Fuel oil, free.

Lubricating oil, 25 öre per 50 kilograms.

## INDO-CHINA.

Mineral oils of all kinds, 4 francs per 100 kilograms.

## ITALY.

Petroleum, crude, 8 litre per quintal.

Paraffin, solid, ceresin, and vaseline, 15 litre per quintal.

Benzine, 24 lire per quintal.

Statistical duty of 10 centesimos per quintal on mineral oils and solid paraffin.

## JAMAICA.

Naphtha, gasoline, and petrol, 5d. per gallon.

Crude petroleum, free.

Wax candles, 2d. per pound.

Other products of petroleum, 4d. per gallon.

## JAPAN.

Crude mineral oils, from 0.17 yen to 0.36 yen per 10 American gallons, according to percentage of distillates between 120° and 275° C.

Mineral oils, with a specific gravity exceeding 0.904 at 15° C., to be used directly as fuel, free.

Candles of all kinds, 11 yen per 100 kins.

Paraffin wax, up to 45° C. melting-point, free; other, 3.45 yen per 100 kins.

Coal tar, free.

Vaseline, 2.95 yen per 100 kins.

## JERSEY.

Paraffin and the like, 6d. per barrel.

Benzoline and motor essences, 10s. per ton.

## LABUAN.

Petroleum, rock oils, and wax, all kinds, free.

## LAGOS.

Kerosene and all other lamp oils, 3d. per imperial gallon.

Petrol and other refined motor spirits, 8d. per imperial gallon.

## LIBERIA.

Kerosene, 30 cents per case.

## LOANDA, BENGUELA, AND MOSSAMEDES.

Petroleum, 20 reis per kilogram, net.

Candles, 70 reis per kilogram, net.

Tar, 20 reis per kilogram, net.

Other products, 20 per cent. *ad valorem*.

## MACAO.

Petroleum and its products, free.

## MADAGASCAR.

Customs duties : Petroleum and other mineral oils for lighting, 3 francs per 100 kilograms.

Consumption duties : Petroleum, schist, and other mineral illuminating oils, crude or refined, and essences, 10 centimes per kilogram, net. Paraffin candles, 20 centimes per kilogram, net.

## MALAY PROTECTED STATES, BRITISH.

Kedah : Petroleum, 10 cents per tin.

Perlis : Kerosene oil, 20 cents per 4 gallons, free at Sanglang.

Trengganu : Kerosene oil, 15 cents per case.

Kelantan : Kerosene oil, benzine, and other inflammable oils, 10 cents per gallon.

## MALTA.

Oils to be used for industrial purposes, free.

Petroleum and petrol spirits, 1s. 10d. per hectolitre.

Paraffin wax, 5 per cent. *ad valorem*.

## MARTINIQUE.

Customs tariff : Paraffin, free ; petroleum, schist, and other mineral illuminating oils, refined and essences of, free.

Sea-octroi duties : Petroleum, schist, and other mineral illuminating oils, 12 centimes per litre.

## MASKAT.

Petroleum, crude, and its products, 5 per cent. *ad valorem*.

## MAURITIUS.

Petroleum, including rock oil, Burma oil, Rangoon oil, or any product thereof, also any oil made from petroleum, schist, shale, or other bituminous substance, or products thereof which give off an inflammable vapour at a temperature of less than 73° F., 4 rupees 80 cents per hectolitre.

Petrol spirits, 6 rupees per hectolitre.

All other mineral oils, 4 rupees per hectolitre.

## MAYOTTE AND COMORES.

Duties similar to Madagascar.

## MEXICO.

Mineral oil, not refined, free.

Mineral oil, refined, benzine, paraffin, and mineral wax, 10 cents per kilogram, legal.

Lubricating oils, 7 cents per kilogram, gross.

Benzol, gasoline, and other petroleum ethers, refined petroleum suitable for burning (gas oil) and similar oils, free.

Candles or wax tapers, 75 cents per kilogram, gross.

Coal tar, 5 cents per kilogram, gross.

Vaseline, 12 cents per kilogram, gross.

## MONTSERRAT.

Petroleum and its products, 2s. 3d. per case of 8 gallons.

Oil for use in oil engines as fuel, free.

## MOROCCO.

Crude petroleum and its products, 10 per cent. *ad valorem*, with a special tax of  $2\frac{1}{2}$  per cent. *ad valorem*.

## MOZAMBIQUE.

Transmarine Provinces : Light mineral oils for illuminating (except petroleum), \$0.67 per kilogram ; medium mineral oils, \$0.60 per kilogram ; heavy mineral oils for lubricating machinery, \$0.02 per kilogram ; petroleum, 20 reis per 100 kilograms.

Manica and Sofala territories : Petroleum, 0.020 milreis per kilogram (tare); candles, 0.070 milreis per kilogram (tare) ; tar, pitch and coal tar, 0.005 milreis per kilogram (tare) ; other products, 10 per cent. *ad valorem*.

## NEVIS ISLANDS.

Kerosene, 3d. per gallon.

Lubricating oil, 1s. 0d. per gallon.

Petrol and gasolene, 4d. per gallon.

Petroleum for use as fuel in or about any oil engine now or hereafter erected in the Presidency, free.

Other products,  $13\frac{1}{3}$  per cent. *ad valorem*.

## NEWFOUNDLAND.

Kerosene, when in packages made of wood, free ; in iron or steel packages, 5 cents per imperial gallon.

Naphtha to be used by manufacturers in the manufacture of copper paint, free.

Naphtha, gasoline, benzine, and all illuminating oils not elsewhere specified, 6 cents per imperial gallon.

Lubricating oil and axle grease, 25 per cent. *ad valorem*.

Paraffin wax, vaseline, and all similar preparations of petroleum for toilet, medicinal, or other purposes, 30 per cent. *ad valorem*.

Candles, 25 per cent. *ad valorem*.

Tar, 15 per cent. *ad valorem*.

## NEW CALEDONIA.

Customs tariff: Petroleum, schist oils, and other oils suitable for illuminating purposes; oils, heavy; residues of petroleum and other mineral oils; paraffin and vaseline, free.

Sea-octroi tariff: Petroleum, schist, and other mineral illuminating oils, crude, refined, and essences, 2.50 francs per 100 kilograms, gross.

Heavy oils and residues of petroleum and other mineral oils, 1 franc per 100 kilograms, gross.

Candles, 15 francs per 100 kilograms, net.

## NEW ZEALAND.

Kerosene, benzine in bulk, also shale oil once run, suitable for gas making,  $\frac{1}{2}$ d. per gallon.

All other mineral oil, including shale, waste, or other unrefined mineral oil,  $7\frac{1}{2}$ d. per gallon.

Paraffin wax, 1d. per pound.

## NICARAGUA.

Mineral oil, impure, refined, and petroleum of all kinds, 6 centavos per gallon.

Gasoline, benzine, and crude paraffin, 2 centavos per gallon.

Paraffin candles, 5 centavos per kilogram.

Paraffin ornaments and articles not otherwise specified, 16 centavos per kilogram.

Vaseline, plain, \$7.50 per 100 kilograms.

Coal tar, \$1 per 100 kilograms.

All gross weight.

## NIGER TERRITORIES.

Kerosene, and all other lamp oils, 3d. per imperial gallon.

Petrol and other refined motor spirits, 8d. per imperial gallon.

All other petroleum products,  $12\frac{1}{2}$  per cent. *ad valorem*.

## NORFOLK ISLAND.

Oil, kerosene, naphtha, and gasoline, 3d. per gallon.

## NORWAY.

Petroleum, crude and refined, in the form of illuminating oils, benzine, and the like, free.

Vaseline, axle grease, and petroleum residuum, 4 öre per kilogram.

Wax, free.

## PANAMA.

Petroleum and its products, 10 per cent. *ad valorem*.

## PAPUA.

Benzine, benzoline, crude petroleum, gasoline, naphtha, petrol, residual oil, engine distillate, kerosene below 150° test, liquid fuel, free.

## PARAGUAY.

Crude petroleum, or unrefined naphtha, free.

Naphtha, kerosene, or petroleum, used for lighting purposes, 35 per cent. on a valuation of 10 centavos gold per kilogram.

Wax candles, 35 centavos per kilogram.

## PERSIA.

Heavy oils, exclusively for fuel or lubricating purposes : in bulk, 5 cents per batman ; in drums or tins, 10 cents per batman.

All other mineral oils : in bulk, 15 cents per batman ; in tins, drums, or barrels, 20 cents per batman.

Mineral tar, 25 cents per batman.

Candles, 1 kran per batman.

## PERU.

Petroleum, crude, 5 centavos per 100 kilograms.

Gasoline, naphtha, paraffin, petroleum, or kerosene, 6 centavos per kilogram.

Paraffin, in paste or lumps, 2 centavos per kilogram, gross.

Paraffin candles, 22 centavos per kilogram, including weight of boxes.

Other goods which are duty free under the tariff, 8 per cent. *ad valorem*.

All other articles which are subject to import duty, 30 per cent. *ad valorem*.

## PHILIPPINE ISLANDS.

Mineral oils, crude or refined, including those for illumination, lubrication, fuel, or solvents ; vaseline (except when compounded with other substances) ; axle grease of all kinds and asphaltums, 25 cents per 100 kilograms, gross. (Provided that no article shall pay a less rate than 10 per cent. *ad valorem*.)

Crude mineral wax, 10 per cent. *ad valorem*.

Mineral wax in candles, 20 per cent. *ad valorem*.

## PORTUGAL.

Light mineral oil, for illuminating purposes, density below 0.820, 6.7 centavos per kilogram.

Medium mineral oil, density 0.820 to 0.860, 6 centavos per kilogram.

Heavy mineral oil, for lubricating machines, and mineral substances and their products, density above 0.860 (including paraffin, refined or not), 0.2 centavos per kilogram.

Fuel oil, 34.50 escudo per metric ton.

Crude mineral wax, 2.5 centavos per kilogram, gross.

## PORTUGUESE CONGO.

Petroleum and its products, 10 per cent. *ad valorem*.

## PORTUGUESE GUINEA.

Petroleum and its products, 3 per cent. *ad valorem*.

## PORTUGUESE INDIA.

Kerosene, 1 anna per imperial gallon.

## REUNION ISLAND.

Petroleum and schist oils, and other mineral oils, fit for illuminating purposes, 1 franc per 100 kilograms, gross.

Statistical duty of 15 centimes per package or set of packages, or 30 centimes per 1000 kilograms.

## RUMANIA.

Petroleum, crude, any quality, and schist oil, 2 lei per 100 kilograms.

Petroleum, refined, 5 lei per 100 kilograms.

Benzine, 5 lei per 100 kilograms.

Chemical products derived from crude oil, free.

Ozokerite (mineral wax), paraffin, and ceresin, 80 lei per 100 kilograms ; if manufactured into candles or other articles, 100 lei per 100 kilograms.

Coal tar, 1 lei per 100 kilograms.

## RUSSIA.

Petroleum, black, not purified, of every kind, 33 copecks per pood.

Liquid products obtained from the distillation of petroleum (kerosene, photogen, solar oil, paraffin oil, and lubricating oils, naphtha ether, gasoline, ligroin, benzine, and the like), 1 rouble 98 copecks per pood.

Mineral tar, 33 copecks per pood.

Ozokerite, even melted, 85·8 copecks per pood gross.

Ozokerite, refined (ceresin) ; paraffin, vaseline (with the exception of refined vaseline, without odour or taste), 3 roubles 64·65 copecks per pood, gross.

Candles of all kinds ; torches and tapers, 5 roubles 54·4 copecks per pood.

Greasy substances of all kinds for axles, wheels, etc., with wax, or oil, 4 roubles 40 copecks per pood.

## SABA.

Petroleum, 80 cents per 100 litres.

Crude petroleum and petroleum residues, free.

## SALVADOR.

Gasoline, and crude petroleum for use as fuel, 5 centavos per kilogram.

Kerosene, petroleum, and naphtha, 6 centavos per kilogram.

Non-purified lubricating oil and grease for machines, imported in receptacles holding at least 5 gallons, 4 centavos, per kilogram.

Lubricating oil, clarified, purified, or of better quality, for fine machines, such as sewing-machines, clockwork, etc., 8 centavos per kilogram.

Paraffin in cakes, 3 centavos per kilogram ; manufactured in any form, 18 centavos per kilogram.

Taxes amounting to \$8 per 100 kilograms are also charged on imported goods.

## SARAWAK.

Kerosene, 20 cents per case of 8 imperial gallons ; in drums, casks, etc., 2½ cents per imperial gallon.

Other products, free.

## SERVIA, CROATIA, AND SLAVONIA (YUGOSLAVIA).

Refined kerosene, monopoly.

Naphtha, raw, black and unrefined, naphtha residues from the extraction of benzine and kerosene, 1·50 dinar per 100 kilograms.

Gasoline, ligroin, benzine, lubricating oils, so-called paraffin oil, and pure solar oil ; in barrels or tanks, 6 dinars per 100 kilograms, net ; in other receptacles, 40 dinars per 100 kilograms, net.

Asphalt or mineral pitch, 1 dinar per 100 kilograms.

Ozokerite, raw or melted, 2 dinars per 100 kilograms.

Paraffin candles, 100 dinars per 100 kilograms.

Vaseline, in barrels, 20 dinars per 100 kilograms; in other receptacles, 60 dinars per 100 kilograms.

#### SEYCHELLES.

Petroleum, including rock oil, Rangoon oil, Burma oil, or any product thereof; also any oil made from petroleum, coal, schist, shale, peat, or other bituminous substance or products thereof, which give off an inflammable vapour at a temperature of less than 100° F., prohibited.

All other mineral oils and wax of all kinds, 15 per cent. *ad valorem*.

#### SIAM.

Petroleum and its products, 3 per cent. *ad valorem*.

#### SIERRA LEONE.

Petroleum, rock oil, Rangoon oil, Burma oil, or oil made from coal, schist, shale, peat, or other bituminous substances, also all products thereof, if giving off an inflammable vapour at a temperature below 95° F., prohibited.

Other, 6d. per gallon.

Naphtha in a crude state, 15 per cent. *ad valorem*.

#### SOMALILAND PROTECTORATE.

Petroleum and its products, imported at Zeyla, 5 per cent. *ad valorem*; imported at Berbera and Bulhar, 7 per cent. *ad valorem*.

#### SOUTHERN NIGERIA PROTECTORATE.

(See Niger Territories.)

#### SOUTH AFRICAN CUSTOMS UNION.

(Cape Colony, Natal, Bechuanaland Protectorate, Basutoland, Orange River Colony, Transvaal, Southern Rhodesia, Swaziland, and Protectorate of South-West Africa.)

Motor spirit, namely benzine, benzoline, naphtha (not potable), gasoline, petrol, and petroleum spirit generally, 2d. per imperial gallon.

Lubricating oil, 3d. per imperial gallon.

Mineral oils, illuminating and burning, having a specific gravity of less than 0.900 at 60° F., and a flash-point of less than 150° F., 1d. per imperial gallon.

Paraffin wax ordinarily used in the manufacture of candles, free.

Asphalt, 3 per cent. *ad valorem*.

#### SPAIN.

Natural crude oils, fuel oil, and the like, with density over 0.925 at 15° C., and residues of petroleum, called also tar, asphalt, and pitch of petroleum, which contain 30 to 70 per cent. of sulphuric tar, 18 pesetas per 100 kilograms.

Petroleum and mineral oils up to 0.925 density, which leave more than 20 per cent. of residue on distillation at 300° C., 45 pesetas per 100 kilograms.

Petroleum and mineral oils which leave less than 20 per cent. of residue, 45 pesetas per 100 kilograms.



Dark-coloured petroleum, over 0.915 density, more than 12 per cent. of sulphuric tar, and flash-point below 100°, 45 pesetas per 100 kilograms.

Kerosene, petroleum which leave on distillation at 300° C. more than 20 per cent. of residue, 45 pesetas per 100 kilograms.

Oleonaphtha, mineral lubricating oils, vaseline, and mixtures of these products, and residues of petroleum which contain from 10 to 30 per cent. of sulphuric tar, 80 pesetas per 100 kilograms.

Benzine (petrol), and other similar products, 160 pesetas per 100 kilograms.

Gasoline, 100 pesetas per 100 kilograms.

Paraffin wax, in lumps, 90 pesetas per 100 kilograms, gross ; manufactures, 200 pesetas per 100 kilograms.

#### STRAITS SETTLEMENTS.

Petroleum, rock oil, and wax, all kinds, free.

#### ST. CHRISTOPHER.

(See Nevis Island.)

#### ST. CROIX.

Petroleum and its products, 12½ per cent. *ad valorem*.

#### ST. EUSTACHE.

Petroleum, 80 cents per 100 litres.

Crude petroleum and petroleum residues, free.

#### ST. HELENA.

Petroleum, rock oils, and wax, all kinds, free.

#### ST. LUCIA.

Fuel oil, kerosene, and other refined burning oils, motor spirit, including benzine, benzoline, gasoline, naphtha, and petrol spirits generally, 5d. per gallon.

Lubricating oil, 7d. per gallon.

Asphalt and tar, 15 per cent. *ad valorem*.

#### ST. MARTIN.

(Dutch part.)

Petroleum, 80 cents per 100 litres.

Crude petroleum and petroleum residues, free.

#### ST. PIERRE AND MIQUELON.

Mineral (schist) and petroleum oils, 6 francs per 100 kilograms.

Gasoline, 7 francs per 100 kilograms.

Heavy oils and residue of petroleum, and other mineral oils, 5 francs per 100 kilograms.

Paraffin and vaseline, 9 francs per 100 kilograms.

Statistical tax of 15 centimes per package, or per 1000 kilograms when in bulk.

## ST. THOMAS' AND PRINCES' ISLANDS.

Petroleum, 20 reis per kilogram.

Other products, 25 per cent. *ad valorem*.

## ST. VINCENT.

Fuel oil and lubricating oil, free.

Illuminating oil, including kerosene and other refined petroleum for burning oils, 2½d. per gallon.

Motor spirit, including benzine, benzoline, gasoline, naphtha, and petrol spirits generally, 4d. per gallon.

## SURINAM.

(See Dutch Guiana.)

## SWEDEN.

Mineral oils, natural or crude, also purified, such as illuminating and lubricating oils, petroleum, benzine and gasoline; paraffin wax, raw or purified; mineral wax (ozokerite) and ceresin, free.

Paraffin candles, 12 öre per kilogram, including weight of package.

Vaseline, grease for lubricating machinery, and carriage grease, including the weight of receptacles, 2 öre per kilogram.

Coal tar, free.

## SWITZERLAND.

Petroleum and products from the distillation of petroleum (gasoline, kerosene, kerosene, ligroin, neoline, solar oil), 3 francs per 100 kilograms.

Grease, all kinds for machinery; paraffin grease, 5 francs per quintal.

Vaseline, crude or purified; vaseline oil (paraffin oil), 1 franc per 100 kilograms:

Paraffin and ceresin, pure, not manufactured; ozokerite, 1 franc per 100 kilograms.

Candles of all kinds, 16 francs per 100 kilograms.

Duties based on gross weight.

## TOGOLAND.

Petroleum and illuminating oils, ¾d. per litre.

Other products, 10 per cent. *ad valorem*.

## THE NETHERLANDS.

Petroleum, crude and refined, benzine from petroleum, and naphtha of any sort, 0.55 florin per 100 kilograms, net.

Wax candles and wax wares, 5 per cent. *ad valorem*.

## TRINIDAD AND TOBAGO.

Fuel oil; illuminating, including kerosene and other refined petroleum burning oils; motor spirit, including benzine, benzoline, gasoline, naphtha, and petrol spirits generally, 4d. per gallon.

Lubricating oils, 6d. per gallon.

Candles, 6s. 0d. per 100 pounds.

## TUNIS.

Petroleum, schist, and other mineral illuminating oils, crude, refined, and essences of, 5 francs per hectolitre.

Heavy oils and residues of petroleum and other mineral oils: lubricating and other oils, 5 francs per 100 kilograms, net.

Coal tar, bitumen, and asphalt, free.

Mineral wax or ozokerite: crude, 6 francs per 100 kilograms, gross; refined, 7 francs per 100 kilograms, gross.

Paraffin wax, 6 francs per 100 kilograms, net.

Vaseline, 8 francs per 100 kilograms, net.

## TURKEY.

Petroleum and its products, 11 per cent. *ad valorem*.

## TURKS AND CAICOS ISLANDS.

Mineral oil, petroleum, or kerosene, 1d. per gallon.

## UGANDA PROTECTORATE.

Petroleum and its products, 10 per cent. *ad valorem*.

## UNITED STATES.

Petroleum, crude or refined, and all products obtained from petroleum, including kerosene, benzine, naphtha, gasoline, paraffin, and paraffin oil, free.

## URUGUAY.

Petroleum, crude, 1 centavo on a valuation of 2 centavos per litre, net.

Naphtha or benzine, crude, 48 per cent. on a valuation of 10 centavos per litre, net.

Gasoline, 31 per cent. on a valuation of 6.50 pesos per hectolitre, net.

## VENEZUELA.

Petroleum, crude, 10 centimos per kilogram, gross.

Kerosene and lubricating oil (crystal sperm), 25 centimos per kilogram, gross.

Benzine, gasoline, and naphtha, 5 centimos per kilogram, gross.

Heavy mineral oils, suitable for fuel; mineral tar and asphalt, 10 centimos per kilogram, gross.

Paraffin, pure or mixed, 37.5 centimos per kilogram, gross.

Candles made of paraffin, 1.25 bolivar per kilogram, gross.

## VIRGIN ISLANDS.

Petroleum and its products, 1s. 6d. per case of 8 gallons.

Paraffin candles, 16s. 8d. per 100 pounds.

## ZANZIBAR PROTECTORATE.

Petroleum and its products, 7½ per cent. *ad valorem*.

Kerosene, paraffin, petroleum, or other explosive oil with a flash-point below 73° F. by the Abel-Pensky close test, prohibited.

## APPENDIX C.

## THAMES CONSERVANCY.

BYELAWS FOR THE REGULATION OF PETROL MOTOR LAUNCHES  
ON THE RIVER THAMES.

*The Conservators of the River Thames in exercise of the powers and authority vested in them by the Thames Conservancy Act 1894 do make the following Byelaws that is to say:—*

1. These Byelaws may be cited as "The Thames Motor Launch Byelaws 1906" and shall come into operation the day after the same are confirmed by the Board of Trade.

2. These Byelaws shall be applicable to the Thames as defined by the Thames Conservancy Act 1894.

3. In these Byelaws the words and expressions hereinafter mentioned shall have the meanings hereby assigned to them respectively unless there be something in the subject or context repugnant to such construction viz:—

The expression "petrol motor launch" means any vessel in which the motive power is supplied by petroleum to which the Petroleum Acts 1871-1879 apply whether such petroleum is used in an internal combustion engine or for the generation of steam or otherwise but the said expression shall not include a petrol motor launch having no petroleum on board when being towed.

The word "master" when used in relation to any petrol motor launch means any person whether the owner master or other person lawfully or wrongfully having or taking the command charge or management of the petrol motor launch for the time being. The expression "Officer of the Conservators" means any lockkeeper or other officer of the Conservators or any person employed by them and authorised by writing under their Common Seal to carry out the provisions of these Byelaws.

4. No petrol motor launch shall be navigated into or through any lock on the Thames unless it is constructed in accordance with the following requirements:—

- (a) Carburettors (the design or construction whereof may in any circumstances permit of an overflow) so fitted as in the event of an overflow to drain into a gauze-covered receptacle capable of being emptied from time to time as may be necessary and of a form to be approved by the Conservators.
- (b) Fuel tanks constructed of copper or an alloy of copper rivetted or of steel efficiently galvanised after making up, and their freedom from leakage or liability to leakage ascertained by testing.
- (c) A closed locker provided for the stowage of petrol cans whether containing petrol or not such closed locker not to be placed in close proximity to the exhaust pipe.
- (d) Fuel tanks installed in such a position that ready access can be had to all connections.
- (e) All fuel pipes of seamless drawn copper or other tubing approved by the Conservators.
- (f) Fuel pipes fitted with ground cone union joints or other approved form of joint and not with flange or socket joints. The main fuel pipe provided with suitable means for giving it the necessary elasticity. If bends or coils are fitted one should be placed close to the fuel tank and another close to the carburetter.
- (g) Fuel pipes carried where they are least liable to become damaged and in all cases so fitted that ready access can be had to them and all connections throughout their entire length.
- (h) One cock fitted to the fuel feed pipe where it leaves the tank and another where it joins the carburetter. Provided that in respect of petrol motor launches registered prior to the date when these Byelaws come into operation and having only one cock in the fuel feed pipe the Inspector of the Conservators shall exercise his discretion as to the necessity of a second cock to such pipe.
- (i) The exhaust pipe water cooled unless taken into a funnel. Where the exhaust pipe is taken into a funnel provision made to prevent liability of ignition of inflammable vapour in any part of the boat.
- (j) The silencer effective as regards suppression of noise of exhaust to the satisfaction of the Conservators and constructed of sufficient strength to prevent it being injured by the occurrence of an explosion therein.
- (k) A spirit-tight tray or receptacle the sides of which are carried up as high as the propeller shaft will permit of fitted beneath the engine so as to prevent leakage of spirit and lubricating oil escaping into any other part of the boat.

## IGNITION ARRANGEMENTS.

- (l) The ignition circuit throughout carefully insulated. High tension leads from coil to sparking plugs carried through a water-tight tube or so installed as to prevent leakage of current or risk of breakage or damage by water.
- (m) Electric leads properly supported.
- (n) If a "spark gap" be employed it must be so enclosed as not to be capable of igniting inflammable vapour.
- (o) Some form of sparking plug employed in which external sparking is as far as possible guarded against.
- (p) If trembler coils are employed the same must be placed in a position where an accumulation of inflammable vapour is not likely to occur.
- (q) No form of hot tube ignition employed.

5. The master of every petrol motor launch whilst waiting to enter or when in any lock on the Thames shall give to any Officer of the Conservators reasonable facilities to inspect such petrol motor launch with a view to ascertaining whether the aforesaid requirements are complied with.

6. Whilst waiting to enter or when in any lock on the Thames the master of any petrol motor launch and the person or persons on board the same shall comply with the following regulations:—

- (a) Having entered a lock the cock on the fuel feed pipe shall immediately be closed and shall not be re-opened until the lock gates are opened for the egress of the vessel or vessels then in the lock.
- (b) In any lock the engine shall be stopped before the lock gates are closed and shall not be re-started until the gates are opened for the egress of the vessel or vessels then in the lock. Provided that sub-sections (a) and (b) of this Byelaw shall not apply to a petrol motor launch when no other vessel is passing through the lock at the same time as the petrol motor launch or when the only other vessel or vessels passing through the lock at the same time as the petrol motor launch is or are a vessel or vessels of the same type.
- (c) No fuel tank or petrol can shall be opened or manipulated on any petrol motor launch.
- (d) Any petrol carried in excess of that contained in the fuel tanks shall be carried only in two-gallon cans of a pattern approved by the Railway Clearing House for conveyance of petrol by the Railway companies. Such cans whether containing petrol or not shall be stowed in a closed locker which must not be used for any other purpose while any petrol can is therein.
- (e) No person shall strike a match whilst on any petrol motor launch. Provided that this regulation shall apply only when such petrol motor launch is in a lock.
- (f) With a view to prevention of fire a proportionate quantity of sand equal to one-half a cubic foot for every complete twelve feet in length of the hull of the petrol motor launch together with a shovel or scoop shall be carried in some readily accessible place. Provided that in the event of the Conservators approving in writing under the hand of their Secretary a form of chemical fire extinguisher such approved chemical fire extinguisher may be carried in place of sand as aforesaid.

7. Any person acting in contravention of any of these Byelaws shall for every such act be liable to a penalty not exceeding £10, and in the case of a continuing offence to a further daily penalty not exceeding the like amount which said penalties shall be recoverable enforced and applied according to the provisions of the Thames Conservancy Act 1894.

*NOTE.—The Conservators will be prepared to inspect any petrol motor launch registered under the Thames Conservancy Act 1894 and grant to the owner of such launch if on such inspection it be found to satisfy the requirements as to construction a certificate of compliance with reference to that part of these Byelaws relating to construction.*

*Such certificate of compliance will not however exempt the master of such petrol motor launch from liability to have his vessel further inspected from time to time in order that it may be ascertained whether the construction has been maintained in accordance with the aforesaid requirements.*

*Applications for inspection of petrol motor launches should be addressed to the Secretary, Thames Conservancy, 2 Norfolk Street, Strand, W.C. 2.*

The Common Seal of the Conservators of the River Thames was hereunto affixed by order of the said Conservators in the presence of

ROBERT PHILIPSON,

Secretary of the said Conservators.



In pursuance of the powers conferred upon the Board of Trade by the Thames Conservancy Act 1894, the Board of Trade do by this Order confirm the Byelaws made by the Conservators of the River Thames on the Thirtieth day of July 1906, under their Common Seal and the signature of their Secretary, and which Byelaws are herewith annexed.

Dated this 11th day of August 1906.

By order of the Board of Trade,  
H. LLEWELLYN SMITH,  
*Acting Secretary.*

Board of Trade,  
Whitehall Gardens,  
London, S.W.

*Every vessel propelled by mechanical power and used on the river above Kew Bridge is, by the Thames Conservancy Act 1894, required to be registered, and the charge for a certificate expiring at the 31st December following the date of issue is £1.*

*Forms of application for certificates can be obtained at the Thames Conservancy Office, 2 Norfolk Street, Strand, W.C. 2.*

# BIBLIOGRAPHY.

Compiled by W. H. DALTON, with assistance by L. V. DALTON, S. L. JAMES,  
and E. S. WARD.

PERFECTION in bibliography is impossible. Apart from works issued during the final stages of compilation, there are many whose titles do not connote relation to our subject, and whose detection has depended more or less fortuitously on perusal or on mention in other works. Many somewhat imperfect entries have been admitted, and many more necessarily rejected.

The original has been consulted wherever possible, but there are a good many second-hand entries from prior bibliographies, general and special, and from other sources.

The arbitrary margin to the numerous ramifications of so extensive and complex a subject has not been rigidly retained, since works mainly outside such margin often touch indirectly upon matters fairly within it.

Critical valuation is inadmissible in impartial compilation, and extensive works here entered may be of less intrinsic importance than brief paragraphs to which admission is of necessity denied: of anonymous works, the most important only are entered.

Space precludes mention of various editions, translations, and abstracts, and the insertion of notes.

1. **A.** Die Petrolenleitung der transkaukasischen Bahn von Michailowo bis Batum. *Polyt. Journ.*, bd. cccxv, pp. 19, 20. [1900.]
2. **A—, E.** [Petroleum-spout in the Grozni Field.] *Gorn. Journ.*, 1893, t. 4, pp. 281-283.
3. **Aagard, H. B.** [Liquid Fuel. Prize Essay. Norwegian Govt.] 1902.
4. **Abbate, E.** Guida della provincia di Roma. *Rome*, 1894.
5. **Abbott, J.** Extracts from a Letter descriptive of Geological and Mineralogical Observations in the Huzaree District. *Journ. As. Soc. Bengal*, vol. xvi, pp. 1135-1137. [1847.]
6. **Abbott, J. W.** Use of Mineral Oil in Road Improvement. *Yearbook U.S. Dept. Agric.*, 1902, pp. 479-484; 3 pls.
7. **Abel, F. A.** Official Report on Chemical Inventions. *Off. Rep. London Internat. Exhib.*, 1871.
8. ——— On Accidental Explosions. *Proc. Royal Inst.*, vol. vii, pp. 390-429. [1875.]
9. ——— Report to the Secretary of State for the Home Department on the Subject of the Testing of Petroleum. *Fo, London*, 1876.
10. ——— Accidental Explosions produced by Non-explosive Liquids. *Chem. News*, vol. ii, pp. 183-187, 195-198, 208-211. [1885.]
11. **Abel, F. A., and B. Redwood.** Petroleum Testing in Tropical Climates with Abel's Apparatus. *Chem. News*, vol. xlix, p. 196. [1884.]
12. ——— [On Petroleum Lamps and their Danger.] *Polyt. Journ.*, bd. cclxii, pp. 416-418. [1886.]
13. ——— Accidents with Mineral Oil Lamps. Report to Home Office. *Fo, London*, 1890.
14. **Abel, J.** Gewinnung von Mineralien zur Fabrikation von Oel und Fettsstoffen. *Oesterr. Zeitschr. Berg-Huu.*, bd. iv, p. 173. [1856.]
15. **Abeleira, M.** Minas de Petroleo de la Provincia de Burgos. *Rev. Min.*, t. xxix, pp. 257-260. [1878.]
16. **Abella y Casariego, E.** Descripcion Fisica, Geologica y Minera en bosquejo de la Isla de Panay. 8vo. *Manila*, 1890.
17. **Abich, H.** [On Inflammable Gas Springs near Baku, and on Variations of the Level of the Caspian Sea.] *Gorn. Journ.*, 1847, t. 3, pp. 400-402.
18. ——— Höhen-Bestimmungen in Daghestan und in einigen transcaucasischen Provinzen. *Ann. Phys. Chem.*, bd. clii, pp. 149-158. [1849.]
19. ——— [Emanations of Inflammable Gas in Southern Russia.] *Jahresb. Fortsch. rein Chem.*, 1855, p. 1003.
20. ——— Sur les derniers tremblements de terre dans la Perse Septentrionale et dans le Caucase, ainsi que sur des eaux et des gaz s'y trouvant en rapport avec ces phénomènes. *Bull. Ac. Imp. Sci. St. Pétersb.*, t. xiv, pp. 49-72. [1856.]
21. ——— Ueber Schlammvulkane und ihre Bedeutung für die Geologie. *Ber. Vers. deutsch. Nat.*, bd. xxxiii, p. 101. [1857.]
22. ——— Ueber die Erscheinung brennenden Gases im Krater des Vesuvius in Juli 1857, und die periodischen Veränderungen welche derselbe erleidet. *Bull. Ac. Imp. Sci. St. Pétersburg*, t. xvi, pp. 258-270. [1858.]
23. ——— [Earthquakes at Schemakha and Erzerum in May 1859.] *Gorn. Journ.*, 1861, t. 4, pp. 101-120.
24. ——— Ueber eine im Caspischen Meere erscheinene Insel, nebst Beiträgen zur Kenntniss der Schlammvulkane der Caspischen Region. *Mém. Ac. Imp. Sci. St. Pétersb.*, sér. 7, t. vi, no. 5. [1863.]
25. ——— [Geological Map of the Caspian Mud-Volcanos.] *St. Pétersburg*, 1863.
26. ——— [Structure of the Apscheron Peninsula.] *Zap. Kavk. Otd. Imp. Russk. Geogr. Obsch.*, t. vi, pp. 129-153. [1874.]

27. **Abich, H.** Études sur les presqu'iles de Kertsch et de Taman. *Bull. Soc. Géol. France*, sér. 2, t. xxi, pp. 259-279. [1864.]
28. — Einleitende Grundzüge der Geologie der Halbinseln Kertsch und Taman. *Mém. Ac. Imp. Sci. St. Pétersb.*, sér. 7, t. ix, no. 4, pp. 86. [1865.]
29. — [Caucasian Researches: Mineral Springs and Salt Deposits.] *Kark. Kalend.*, 1865, pp. 203-240.
30. — Zur Geologie des südöstlichen Kaukasus. Bemerkungen von meinen Reisen im Jahre 1865. *Bull. Ac. Imp. Sci. St. Pétersb.*, sér. 2, t. x, pp. 21-42. [1866.]
31. — Ueber das Vorkommen des brennbaren Kohlenwasserstoffs in den Gasemengen der Caucasischen Thermen. *Ibid.*, t. xi, pp. 397-412. [1867.]
32. — Ueber die Naphta-Bezirke des Nordwestlichen Caucasus. *Bull. Soc. Imp. Nat. Mosc.*, t. xi, pp. 289-323. [1867.]
33. — Mittheilungen über Erdbeben, vulcanische Erscheinungen (? Schlammmvulkanen) u.s.w. in den Caucasus-Ländern. *Mith. k.-k. geogr. Ges. Wien*, bd. xii, pp. 166-175. [1869.]
34. — Ueber paraffinhaltende Mineralstoffe auf der apsercherischen Halbinsel. *Bull. Ac. Imp. Sci. St. Pétersb.*, sér. 2, t. xxi, pp. 493-509. [1876.]
35. — Das trialetische Thermalquellensystem in Karthalinien vom geologischen Standpunkte betrachtet. *Zeitschr. deutsch. geol. Ges.*, bd. xxix, pp. 820-829. [1877.]
36. — Geologische Forschungen in den Kaukasischen Ländern. 4to, Vienna, 1878, 1882, 1887.
37. — Ueber die Productivität und die geotektonischen Verhältnisse der kaspischen Naphtaregion. *Jahrb. k.-k. geol. Reichs.*, bd. xxix, pp. 165-188. [1879.]
38. — Ueber das Vorkommen von Petroleum bei Baku. *Verh. k.-k. geol. Reichs.*, 1879, p. 98.
39. — Das Petroleum und die geologischen Bedingungen seines Erscheinens im Kaukasus. *Ibid.*, 1883, pp. 125, 126.
40. — Geologische Fragmente aus den Nachlassungen H. Abich's Karte und Profilen zur Geologie der Halbinseln Kertsch und Taman. Vienna, 1887.
41. — Aus kaukasischen Ländern. 8vo, Vienna, 1896.
42. **Abland, W. E.** A Petroleum Motor. *Journ. Franklin Inst.*, vol. lxxxviii, p. 87. [1874.]
43. **Abraham, A.** Emploi des Résidus de Naphte dans les usines siderurgiques de Russie. *Génie Civ.*, t. xi, pp. 9-11. [1901.]
44. **Abraham, H.** Improved Instruments for the Physical Testing of Bituminous Materials. *Proc. Amer. Soc. Test. Mat.*, vol. ix, pp. 568-579; vol. x, pp. 444-457. [1909, 1910.]
45. **Abriutski, —** [Eruption of Mud-volcanos in the Taman Peninsula, in August 1853.] *Gorn. Journ.*, 1853, t. 4, pp. 271-277.
46. **Abulfeda, J.** Chorasmia et Mawaralnahr vel Regionum extra Fluvium Oxum Descriptio, cum Descriptione Arabiae, Maris Persici et Maris Rubri. 4to, London, 1650.
47. **Accum, F.** Examination of the so-called Salt of Bitumen, the Bit-Nobin of the Hindoos. *Journ. Nat. Phil. Chem. Arts*, vol. v, pp. 251-255. [1803.]
48. **Achiardi, A. d'** Mineralogia della Toscana. 8vo, Pisa, 1872, 1873.
49. **Achille, S.** [Natural Hydrocarbides of the Petroleum Series.] *Ann. Soc. Géol. Nord.*, t. xi, pp. 334, 335. [1884.]
50. **Ackermann, E.** Au sujet de l'existence du pétrole à l'île de Madère. *Rev. Chim. Ind.*, ann. xviii, pp. 263, 264. [1907.]
51. — A la recherche du Pétrole au Portugal. *Bol. Soc. Geogr. Lisb.*, ser. 26, pp. 146-151. [1908.]
52. — Analyse einer Naphta aus dem russischen Turkestan. *Chem.-Zeit.*, bd. xxxiv, p. 440. [1910.]
53. **Acosta, F. d'** Ausbruch des Vulcans Zamba an der Mündung des Magdalenaströms. *Notiz. Nat. Heilt.*, f. 3, bd. xi, pp. 343, 344. [1849.]
54. **Acosta, J.** Relation de l'éruption boueuse sorti du volcan de Ruiz, et de la catastrophe de Lagunilla dans la république de la Nouvelle Grenade. *Rev. Sci.*, t. ix, p. 187. [1846.]
55. — Sur les montagnes du Ruiz et de Tolima (Nouvelle Grenade), et les Eruptions boueuses de la Magdalena. *Bull. Soc. Géol. France*, sér. 2, t. viii, pp. 489-496. [1851.]
56. **Adachi, J.** Petroleum and Natural Gas in Japan. *Min. Res. U.S.*, 1888, pp. 474-478.
57. **Adam, P.** Ether de pétrole; huile de vaseline; vaseline. *Bull. Soc. Chim. Paris*, sér. 3, t. xxxiii, pp. 274-283. [1905.]
58. **Adams, G. I.** Oil- and Gas-Fields of the Western Interior and Northern Texas Coal-measures, and of the Upper Cretaceous and Tertiary of the Western Gulf Coast. *Bull. U.S. Geol. Surv.*, no. 184. Pp. 64, 10 pls. [1901.]
59. — Principles controlling the Geologic Distribution of the Hydrocarbons. *Trans. Amer. Inst. Min. Eng.*, vol. xxxiii, pp. 340-347, 1063-1056. [1902.]
60. **Adams, G. I., E. Haworth, and W. R. Crane.** Economic Geology of the Iola Quadrangle (Kansas). *Bull. U.S. Geol. Survey*, no. 238. Pp. 83. [1904.]
61. **Adams, G. I., and W. E. Pratt.** Miscellaneous Non-Metallic Mineral Products. *Min. Res. Philippine Islands*, 1910, pp. 43-52.
62. **Adams, H. E.** Economy of Firing Benches with Crude Oil. [Experiences, Pacific Coast Gas Assoc.] *Amer. Gas Light Journ.*, vol. lxxv, p. 365. [1901.]
63. **Adams, J. H.** The Geology of the Whatatutu Sub-division, Raukumara Division, Poverty Bay. *Bull. New Zealand Geol. Surv.*, n.s., no. 9. Pp. 48, 3 pls., 5 maps. [1910.]
64. **Adams, L. S.** Motor Boats for Naval Service. *Trans. Inst. Naval Arch. Eng.*, vol. xv, pp. 69-96. [1907.]
65. **Adams, W. B.** Liquid Fuel. *Journ. Soc. Arts*, vol. xvi, pp. 432, 433. [1868.]
66. **Adan, R.** Einiges über Terpentinölanalyse und Mineralbestimmung in Harzessenz. *Zeitschr. angew. Chem.*, bd. xxii, p. 1440. [1909.]
67. — [Lubricant Oils.] *Trav. Lab. Anal. ind. Electrochim.* [1911.]
68. **Adan de Yarza, R.** Descripción física y geologica de la Provincia de Alava. *Mem. Com. map. geol. Españ.* Pp. 176, 3 pls. 4to, Madrid, 1885.
69. **Adda, K. v.** Geologische Aufnahmen im Interesse von Petroleum-Schürfungen in nördliche Theile des Comitates Zemplen in Ungarn. *Mith. Jahrb. kön. ung. geol. Anst.*, bd. xii, pp. 265-319, pl. iv. [1900.]
70. — Geologische Aufnahmen im Interesse von Petroleum-Schürfungen in der Comitates Zemplen und Saros. *Ibid.*, bd. xiii, pp. 145-198, pl. xiv. [1902.] (Hungarian edition, 1900.)
71. **Adiasievitch, A. V.** [Method of Treatment of Naphtha and Bitumens, for obtaining from them Solid Resin and Aromatic Hydrocarbons.] *Zap. Imp. Russk. Tekhn. Obsch.*, g. xxix, Apr., pp. 93-108. [1895.]
72. — Mr. V. Bagosine's Method of Distilling and Fractioning Mineral Oils, obtaining various Products therefrom, and Apparatus for that Purpose. *Petr. Rev.*, vol. 1, pp. 13-16. [1899.]
73. — The Application of Electric Power for Borings and Pumping Wells at Baku. *Ibid.*, vol. 1, pp. 17-23. [1899.]
74. — Preservation of Timber by the Impregnation of Petroleum. 1st *Internat. Petrol. Congr.*, pp. 81-83. [1900.]
75. — Petroleum in the Caucasus. *Petroleum*, vol. 1, pp. 208, 209, 246-248. [1900.]
76. — A New Oil-Field in Turkey. *Petr. Rev.*, vol. II, pp. 281, 282, 327, 328. [1900.]
77. — [Petroleum Deposits of Uralisk Province.] *Izvest. Obsch. Gorn. Inžen.*, 1911.
78. **Adler, A.** Ueber die Rectificationsrückstände der Braunkohlentheerdestillation und einige neue Derivate des Chrysenes. *Ber. deutsch. chem. Ges.*, bd. xii, pp. 1889-1895. [1879.]



79. **Agricola, G.** [= **G. Bauer**]. De Natura Eorum, quae effluunt ex terra. Fo, *Basle*, 1546.
80. ——— De Naturâ Fossilium. Fo, *Basle*, 1558.
81. **Aguilera, J. G.** The Geographical and Geological Distribution of the Mineral Deposits of Mexico. *Trans. Amer. Inst. Min. Eng.*, vol. xxxii, pp. 497-520. [1902.]
82. **Aguirre, E., M. Puiggari,** and **J. J. Kyle**. Carbon fósil de Mendoza. *An. Soc. Ci. Argent.*, t. xv, pp. 270-273. [1883.]
83. **Ahnert, E. v.** [Geological Researches on the East Coast of Russian Sakhalin in 1907.] *Mem. Com. Géol. Russ.*, n. sér., livr. 45. Pp. 219; 4 pls. and map. [1908.]
84. **Ahrens, F. B.,** and **J. Riemer**. Zur Kenntniss des hannoverschen Erdöls. *Zeitschr. angew. Chem.*, bd. xx, pp. 1557-1563. [1907.]
85. **Aikin, A.** Observations on the Wrekin and on the Great Coal-field of Shropshire. *Trans. Geol. Soc.*, vol. i, pp. 191-272. [1811.]
86. ——— [On a Green Waxy Substance found in the alluvial soil near Stockport in Cheshire.] *Ibid.*, vol. iv, p. 445. [1817.]
87. **Aikin, A.,** and **C. R. Aikin**. A Dictionary of Chemistry and Mineralogy. 2 vols. 4to, *London*, 1807; Appendix, 1814.
88. **Ainsworth, W. F.** Researches in Assyria, Babylonia, and Chaldea, forming part of the labours of the Euphrates Expedition. 8vo, *London*, 1838.
89. ——— Notes of an Excursion to Kal'ah Sherkat, the U'r of the Persians, and to the Ruins of Al Hadhr, the Hutra of the Chaldees and Hatra of the Romans. *Journ. R. Geogr. Soc.*, vol. xi, pp. 1-20, pl. [1841.]
90. ——— Travels and Researches in Asia Minor, Mesopotamia, Chaldea and Armenia. 2 vols. 8vo, *London*, 1842.
91. ——— A Personal Narrative of the Euphrates Expedition [of 1837]. 2 vols. 8vo, *London*, 1838.
92. **Aisnmann, S.** Ueber die Hypothesen der Erdölbildung. *Zeitschr. angew. Chem.*, bd. vi, pp. 738-743; bd. vii, pp. 122-126. [1893, 1894.]
93. ——— Ueber die Verharzungsfähigkeit und den sogenannten Harzgehalt der Mineralöle. *Polyt. Journ.*, bd. cxcxiv, pp. 65-68. [1894.]
94. ——— Ueber die Flammpunktbestimmung der Mineralschmieröle. *Ibid.*, pp. 68-70. [1894.]
95. ——— Löslichkeit der Mineralöle in Alkohol. *Polyt. Journ.*, bd. cxcvii, pp. 44-47. [1895.]
96. ——— Taschenbuch für die Mineralöl-Industrie. 8vo, *Berlin*, 1896.
97. ——— Quantitative Bestimmung von Paraffin in Rohödestillaten. *Chem. Rev. Fett- Harz-Ind.*, bd. iv, pp. 106-108, 117-119. [1897.]
98. ——— Die einheitlichen Prüfungsmethoden in der Mineralölindustrie. *Samm. chem.-techn. Vortr.*, bd. ii, pp. 325-400. [1897.]
99. ——— Die destruktive Destillation in der Erdölschmelze. *Ibid.*, bd. v, pp. 189-234. [1900.]
100. ——— Eine neue Methode? *Chem. Rev. Fett- Harz-Ind.*, bd. viii, pp. 8, 9. [1901.]
101. ——— Destillations- und Refinationsmethoden der Schmierölfabrikation. *Ibid.*, bd. ix, pp. 1-4, 25-27. [1902.]
102. ——— Kontinuierliche Destillation in der Erdöl-Industrie. *Compt. Rend. Congr. internat. Chim. Appl.*, sess. 5, t. ii, pp. 510-527. [1904.]
103. ——— Das Petroleum von Bustenari. *Petroleum Zeitschr.*, bd. iii, pp. 565-571. [1908.]
104. ——— Rumänisches Petroleum. *Compt. Rend. Congr. internat. Pétrole*, sess. 3, t. ii, pp. 535-552. [1910.]
105. **Akroyd, W. E.** The Quest for Oil in the Poverty Bay District. *New Zeal. Mines Rec.*, vol. xi, pp. 432-435. [1908.]
106. **Akunians, I. A.** [On Tumski's article on the Petroleum of Ierek and Groznij.] *Trudi Bak. Ord. Imp. Russk. Tekhn. Obsch.*, 1896, Feb., pp. 80-89.
107. **Akunians, I. A.** [On the Fractionating of Petroleum, by Prof. Engler's method and with the aid of the Glinisky dephlegmator.] *Trudi Bak. Ord. Imp. Russk. Tekhn. Obsch.*, pp. 417-428. [1896.]
108. ——— [Crude Oil from Aphurdja, Kuba.] *Ibid.*, 1897, p. 155.
109. **Albertis, C.** Geologische und bergbauliche Skizzen aus Rumänien. *Berg- Hüt. Zeu.*, bd. xlvii, pp. 131, 132. [1888.]
110. **Albrecht, A.** Spezifisches Gewicht der Paraffinsorten. *Zeitschr. Paraff. Ind.*, 1875, p. 1.
111. ——— Ueber die Qualität des amerikanischen Petroleum: kalifornisches und galizisches Petroleum. *Industr. Blatt.*, bd. xvi, p. 170. [1879.]
112. **Albrecht, E.** Die Oelfelder von Kansas und dem Indianer-Territorium (8 Vers. deutsch. Chem.). *Petroleum Zeitschr.*, bd. i, pp. 640-645, map. [1906.]
- Albrecht, E.**, see **Engler, C.**
113. **Albrecht, H.** Die Gefahren in chemischen Reinigungs- und Waschanstalten, Vorsichtsmassregeln gegen Benzin-Explosionen und Brände. *Leipziger Färber-Zeit.*, bd. xlviii, pp. 65, 66, 105-107. [1899.]
114. **Albrecht, M.** Die Braunkohlen-Industrie von Halle und Umgegend. *Zeitschr. Ver. deutsch. Ing.*, bd. xvii, pp. 576-590. [1873.]
115. ——— Das Paraffin und die Mineralöle. 8vo, *Stuttgart*, 1874.
116. ——— Die Schmiermittel. ? *Riga*, 1879.
117. ——— Die Prüfung von Schmierölen. *Riga*, 1879.
118. ——— Ueber das Petroleum von Baku. *Riga Industr.-Zeit.*, bd. iv, p. 171. [1873.]
119. ——— Ueber die Lieferungsbedingungen für Mineralschmieröle bei den königl. preussischen Staatseisenbahnen. *Ann. Gewerbe Bauwesen*, bd. xxx, pp. 234-237. [1892.]
120. ——— Der Erdölbrand zu Harburg. *Polyt. Journ.*, bd. cxcvii, pp. 17-19. [1895.]
121. ——— Ueber den Brennwert des russischen Petroleum. *Chem. Rev. Fett- Harz- Ind.*, bd. v, pp. 189-193. [1898.]
122. **Albrecht, R.** Ueber den Ursprung der optischen Aktivität des Erdöles. 8vo, *Karlsruhe*, 1907.
123. ——— Naphthensäuren. *Chem. Rev. Fett- Harz-Ind.*, bd. xviii, pp. 152-154, 189, 190. [1911.]
124. **Alcala, M.** Criaderos de Petroleo de Pichualco. *Mem. Soc. Ci. Alcala*, t. xiii, pp. 311-326. [1903.]
125. **Alden, W. C.**, see **Fulmer, M. L.**
126. **Aldrich, T. H.** A Texas Oil-well Fossil. *Nautilus*, vol. xv, p. 74. [1901.]
127. **Aldrovandus, U.** *Museum Metallicum*. Fo, *Bologna*, 1648.
128. **Alesi, V.** Sorgenti di gas infiammabile nel fondo prosciugato del Lago Fucino. *Rend. R. Acc. Sci. Napoli*, t. xii, pp. 142, 143. [1873.]
129. **Alexander, —.** Die Verwendung flüssigen Feuerungsmaterialien in der Glas- und keramischen Industrie der Vereinigten Staaten von Nord-America. *Sprechsaal*, bd. xxxvii, pp. 525-527. [1904.]
130. **Alexander, D. B. W.** Methods of Asphalt Analysis. *Compt. Rend. Congr. internat. Chim. appl.*, sess. 5, t. ii, pp. 699-704. [1904.]
131. **Alexander, J. E.** Notice regarding the Asphaltum or Pitch Lake of Trinidad. *Eidnb. N. Phil. Journ.*, vol. xiv, pp. 94-97. [1833.]
132. **Alexiev, P. P.** [Foundry Furnaces heated by Luminous Gas and Volatile Oil.] *Gorn. Journ.*, 1866, t. 3, pp. 295-309.
133. ——— [Current Russian Literature on the Petroleum Industry.] *Kievsk. Univ. Ier.*, 1877, p. 357.
134. ——— [Mud-volcanos of Crimea and Caucasus.] *Zap. Kievsk. Obsch. Estestv.*, kn. vi, pp. 137-162. [1880.]
135. **Alexiev, V.** [Ozokerite in the Western Caucasus.] *Gorn. Journ.*, 1885, t. 2, pp. 478-480.
136. ——— [Caloric Value and Composition of Russian Mineral Combustibles.] *Ibid.*, 1886, t. 3, pp. 446-487; 1887, t. 1, pp. 87-121; 1888, t. 1, pp. 124-143; t. 4, pp. 61-99.

136. **Alexiev, V.** [Elaterite and Dopplerte, Transcaucasia.] *Gorn Journ.*, 1889, t. 1, pp. 361-376.
137. — [A new Ozokerite from Kaluga Government.] *Verh. russ.-k. Min. Ges.*, f. 2, bd. xxix, pp. 201-203. [1893.]
138. — [On the Explosive Properties of Acetylene.] *Gorn Journ.*, 1897, t. 4, pp. 397-400.
139. — [Formation of Hydrocarbons by the Action of Water on Metallic Carbides.] *Ibid.*, pp. 403-406.
140. — [Petroleum—Peat Fuel.] *Zap. Imp. Russk. Tekhn. Obsch.*, g. xxxiii, Trudi, pp. 225-240. [1899.]
141. **Altan, St. E.** [The Influence on the Illuminating Power of Kerosene in Lamps exerted by its Integral parts and the compounds contained in it.] *Trudi Bak. Oid. Imp. Russk. Tekhn. Obsch.*, Jan. 1886, pp. 117-124.
142. **Alibegov, M. G.** [Comparative Investigation of the Lamp of M. G. Alibegov and V. K. Dolinin.] *Zap. Imp. Russk. Tekhn. Obsch.*, g. xxi, Trudi, v. 1, pp. 56-100; v. 3, pp. 17-37; v. 4-5, pp. 33-73, 5 pls. [1887.]
143. — [Kerosene Lamps.] *Ibid.*, g. xxii, v. 2, pp. 108-115. [1888.]
144. **Alimanestianu, H. C.** [The Exploitation of the Rumanian Oilfields.] *Mont. Int. Petrol. Roum.*, t. 1, 1900.
145. — [Rumanian Mining Laws.]
146. — [Rumanian Mining Operations.]
147. — [The Baragan Borings.]
148. — [Rumanian Combustible Minerals.]
149. — Question de la concession des terrains pétrolières situés sur les propriétés de l'état et des conduites pour le transport du pétrole en Roumanie. *Bucharest*, 1900.
150. — Le Sous-Sol de la Roumanie. *Bucharest*, 1900.
151. — Le Rôle de l'Élément Roumain dans l'Exploitation des Richesses Pétrolières du Pays.
152. — Vierzig Jahre rumanischer Petroleumindustrie, 1866-1906. *Petroleum Zeitschr.*, bd. i, pp. 751-753, bd. ii, pp. 4-7. [1906.]
153. — Données statistiques sur l'industrie du pétrole en Roumanie. 8vo, *Bucharest*, 1907.
154. **Alimanestianu, H. C.**, and **L. Edeleanu.** The Petroleum Industry in Rumania. 1st *Internat. Petrol. Congr.*, pp. 5-9. [1900.]
155. — [Rumanian Petroleum from 1899 to 1902.] *Mont. Int. Petrol. Roum.*, t. iv, 1903.
156. **Alimanestianu, H. C.**, **L. Mrazec**, and **V. I. Bratianu.** Travaux de la Commission chargée de l'étude des régions pétrolières de la Roumanie. *Ibid.*, t. v, pp. 675-696. [1904.]
157. — — — — — Considérations générales géologiques et statistiques sur les gisements de pétrole de la Roumanie. *Ibid.*, pp. 697-741. [1904.]
158. **Alippi, T.** Les Boniti du Monte Nerone. *Bull. Soc. belge Géol.*, t. xvii, Trad., pp. 69-75. [1903.]
159. **Allcut, E. A.** Oil Furnaces for Rivet-heating. *Univ. Birmingham Eng. Min. Journ.*, vol. vii, pp. 150-153. [1903.]
160. **Allen, A. H.** Notes on Petroleum Spirit or "Benzoline." *Rep. Brit. Assoc.*, 1879, Sects. pp. 318, 319 [1880]; 1880, Sects. pp. 547, 548 [1881].
161. — On the Relative Proportions of Olefines in Shale and Petroleum Products. *Analyt.*, vol. vi, pp. 177-180. [1881.]
162. — On the Separation of Hydrocarbon Oils from Fat Oils. *Rep. Brit. Assoc.*, 1881, pp. 589, 590.
163. — Note on the Determination of Sulphur in Oils. *Analyt.*, vol. xiii, pp. 43-45. [1888.]
164. — Commercial Organic Analysis. 2 vols. 8vo, London, 1879, 1882.
165. **Allen, B. J.** Some Notes on Oil and Tar Burning. [New England Assoc. Gas Eng.] *Amer. Gas Light Journ.*, vol. lxvii, pp. 432-486. [1900.]
166. **Allen, H.** Modern Power Gas Producer Practice and Applications, 8vo, London, 1908.
167. **Allen, I. C.** Specifications for the purchase of Fuel Oil, with directions for sampling Oil and Natural Gas. *U. S. Bureau of Mines*, Techn. Paper 3, pp. 13. [1911.]
168. **Allen, I. C.**, and **W. A. Jacobs.** Physical and Chemical Properties of the Petroleum Oils of the San Joaquin Valley, California, U.S.A. *Bull. Bureau Mines, U.S.A.*, no. 19, pp. 1-46. [1911.]
- Allen, I. C.**, see **Arnold, R.**
- Allen, L.**, see **Holdé, D.**
169. **Allen, R. P.** The Internal Combustion Engine for Marine Propulsion. *Cassier's Mag.*, vol. xi, pp. 705-736. [1911.]
170. **Allen, T.** An account of the Inflammable Gas-Well on the banks of the Kanawha River in [West] Virginia. *Proc. Amer. Phil. Soc.*, vol. iv, pp. 366-371. [1847.]
171. **Allen, Z.** The Explosibility of Coal Oils. *Ann. Rep. Smithsonian Inst.*, 1862, pp. 330-342.
172. **Allest, J. d'** De la Combustion des huiles minérales et de leurs résidus. *Gen. Civ.*, t. viii, pp. 7-10, 19-22, 36-42. [1885.]
173. — Le Chauffage des Torpilleurs au moyen des hydrocarbures liquides. *Ibid.*, t. xi, pp. 344-348, 362, 363, 397-402. [1887.]
174. — Le Pétrole Solidifié. *Ibid.*, t. xxiii, pp. 396, 397. [1893.]
175. **Almer, W.** Use of Tar in Diesel Engines. *Journ. Gas Lighting*, vol. cxv, p. 106. [1911.]
176. **Almaraz, A.** Estudio é informe sobre el petroleo de Aragon. *Mexico*, 1903.
177. **Altemer, E.** Gisements de pétrole du golfe de Suez. *Journ. Petr.*, t. xi, p. 55. [1911.]
178. **Alth, A.** [Salt and Petroleum in Galicia and Bukovina.] *Spravor. Kom. Fizyogr. Krakow*, t. v, pp. (49)-(93). [1870.]
179. — [Geology of West Galicia.] *Ibid.*, t. vi, pp. 87-143. [1872.]
180. **Alth, A.**, and **F. Bienniaz.** [Descriptive Text to the Geological Atlas of Galicia.] 1887.
- Altmyer, V.**, see **Mayer, M.**
181. **Altukhov, M.** [Heating Furnaces with Oil and its Residue.] *Tekhnik*, 1883, No. 16, p. 6.
182. **Amato, D.** Sulla sintesi degl' idrocarburi condensati. *Gazz. Chim. Ital.*, vol. ii, pp. 6-9. [1872.]
183. **Ambrose, W. C.** The use of Asphaltum in building Sea Walls. *Trans. Amer. Soc. Civ. Eng.*, vol. xxiv, pp. 223-229. [1891.]
184. **Amenc, L.** Notes sur le Graissage des Machines et la fabrication des Huiles à graisser, et sur le Godet Graisseur Automatique. 8vo, Clermont, 1862.
185. **Ami, H. M.** On the sequence of the Geological Formations about Ottawa, with reference to the Natural Gas Question. *Ottawa Nat.*, vol. ii, pp. 93-96. [1888.]
186. — On a new or hitherto unrecognised Geological Horizon in the Gas and Oil Region of Western Ontario. *Journ. Canad. Min. Inst.*, vol. ii, pp. 186-191. [1899.]
187. — On the Geology of the principal Cities of Eastern Canada. *Trans. Roy. Soc. Canada*, ser. 2, vol. vi, sect. 4, pp. 125-164. [1901.]
188. **Auda, M. M. de.** El carbon de piedra mexicana. Le mina del Cristo en la Huasteca. *Min. Mexic.*, t. iii, p. 375. [1875.]
189. — El Petroleo. *Ibid.*, t. iv, pp. 507, 508. [1876.]
- Anderlini, F.**, see **Nasini, R.**
190. **Anderson, A.** Of a Bituminous Lake, or Plain, in the Island of Trinidad. *Phil. Trans.*, vol. lxxix, pp. 65-70. [1789.]
191. **Anderson, A. A.** [Report on Petroleum on the Farm Vetpan, Schoonspruit division, Potchefstroom district, South Africa.] pp. 261-263 of South African Progress, by G. F. Hollis. *Rep. Cons. U.S.A.*, vol. xxxiii, pp. 256-267. [1890.]
192. **Anderson, F. M.** Oil-yielding Formations of Humboldt County. *Bull. Calif. State Min. Bureau*, no. 19, pp. 161-166. [1900.]

193. **Anderson, G.** Description of the Bituminous Rocks which occur in Ross-shire and in the neighbourhood of Inverness. *Edinb. Journ. Sci.*, vol. iv, pp. 93-95. [1826.]
194. ——— On the Occurrence of a Bituminous Substance near Mountgerald [Scotland]. *Quart. Journ. Geol. Soc.*, vol. xix, p. 522. [1863.]
195. **Anderson, Richard.** On the Origin of Petroleum. *Trans. Geol. Soc. Glasgow*, vol. iv, pp. 174-177. [1872.]
196. **Anderson, Robert.** An occurrence of Asphaltite in Northeastern Nevada. *Bull. U.S. Geol. Surv.*, no. 380, pp. 283-285. [1909.]
197. ——— Geology and Oil Prospects of the Reno Region, Nevada. *Ibid.*, no. 381, pp. 475-489. [1910.]
198. ——— Two Areas of Oil Prospecting in Lyon County, Western Nevada. *Ibid.*, pp. 490-493. [1910.]
199. ——— Preliminary Report on the Geology and Oil Prospects of the Cantua-Panoche Region, California. *Ibid.*, no. 431, pp. 58-87. [1910.]
200. ——— Experts and the Productive Area of Californian Oil Fields. *Eng. Min. Journ.*, vol. lxxxix, p. 901. [1910.]
201. ——— Geology of the Cantua-Panoche Oil Region, California. *Bull. U.S. Geol. Surv.*
202. ——— Final Report on the McKittrick-Sunset Oil Region, California. *Ibid.*
- Anderson, R.**, see **Arnold, R.**
203. **Anderson, R. I.** Absorption of Petroleum by some Woods and Rocks. *Compt. Rend. Congr. internat. Pétrole*, sess. 3, t. II, pp. 737-746. [1910.]
204. **Anderson, Thos.** On the Composition of Paraffine from Different Sources. *Rep. Brit. Assoc.*, 1856, Sects., pp. 49, 50. [1857.]
205. ——— On Some Bituminous Substances. *Rep. Brit. Assoc.*, 1865, p. 24.
206. **Anderson, W.** Presidential Address, Section G, Mechanical Science. *Rep. Brit. Assoc.*, 1889. Utilisation, etc., of Petroleum, pp. 725-730.
207. **Anderson, W. J.** On the coal-like substance or "altered bitumen" found in the excavations at Fort No. 3, Point Lewis, and the presently-accepted theories on the origin of coals, bitumen, and petroleum springs, with an account of the "Carboniferous system" of British North America. *Trans. Lit. Hist. Soc. Quebec*, 1865-66, pp. 19-47. [1866.]
208. **Andés, L. E.** Vegetabilische und Mineral-Maschinenöle (Schmiermittel), deren Fabrikation, Raffinierung, Entsauerung, Eigenschaften und Verwendung. 8vo, Vienna, 1893.
209. ——— Das Gasglühlicht und die Herstellung der Glühstrumpfe . . . sowie Darstellung der Glühlichtlampen für flüssige Brennstoffe, nebst einem Anhang über die einschlagigen Patente aller Länder. 8vo. Leipzig, 1902.
210. ——— Praktisches Receptbuch für die gesamte Fett-, Oel-, Seifen- und Schmiermittelindustrie. 8vo, Vienna, 1904.
211. ——— Herstellung von Wachs und Pechfackeln. *Chem. Rev. Fett-Harz-Ind.*, bd. xvi, pp. 83, 84, [1909.]
212. ——— Leinol- und Leinölfirnis-Ersatzmittel. *Ibid.*, bd. xviii, pp. 4-6. [1911.]
213. **Andouard, A.**, and **P. Andouard.** "Esprit Blanc." *Journ. Pharm. Chim.*, sér. 6, t. xv, pp. 99-101, [1902.]
214. **Andrae, C. J.** Ozokeritmassen von Borysaw bei Drobobycz in Galizien. *Verh. nat. Ver. preuss. Rheinl.*, bd. xxiv, *Corresp.-Blatt*, pp. 103, 104. [1867.]
215. ——— [Kerosene Shale, Hartley, New South Wales.] *Ibid.*, bd. xxxii, Sitz., pp. 5-7. [1875.]
216. **Andral, W. A.** Report for the year 1893 on the Trade, etc., of Maracalbo (Venezuela). *Dipl. Cons. Rep.*, ann. ser., no. 1422. [1894.]
217. ——— Report for the year 1895 on the Trade, etc., of Caracas. *Ibid.*, no. 1730. [1896.]
218. **Andreae, A.** Notiz über das Tertiär im Elsass. *N. Jahrb.*, 1882, bd. ii, pp. 287-294.
219. **Andreae, A.** Ein Beitrag zur Kenntniss des Elsassertertiärs. *Abh. geol. Spezialkarte Els.-Lothr.*, bd. ii, h. 3, pp. 277; 12 pls., 2 maps. [1884.]
220. ——— Ueber das elssässische Tertliär und seine Petroleumlager. *Ber. Senckenb. nat. Ges.*, 1887, pp. 23-35.
221. **Andreae, B.** Die neuesten Erfolge des Wassergases in der Leuchtgas-Industrie, deren technischen, etc., Bedeutung. 8vo, Vienna, 1884.
222. **Andreev, —.** [Oil and its Products; Separation of Volatile Oil; Lamps for use of same; Oil as fuel.] *Promischl.*, t. I, pp. 227-246. [1864.]
223. **Andrejew, P.** Analyse des Tschimloner Erdöils. *Petroleum Zeitschr.*, bd. iv, pp. 207-210. [1908.]
- Andrews, C. W.** see **Norton, L. M.**
224. **Andrews, E. B.** Rock Oil, its Geological Relations and Distribution. *Amer. Journ.*, ser. 2, vol. xxxii, pp. 85-93. [1861.]
225. ——— Petroleum in its Geological Relations. *Amer. Journ.*, ser. 2, vol. xlii, pp. 32-43. [1866.]
226. ——— Report of Progress in the Second District. *Rep. Geol. Surv. Ohio*, for 1869, pp. 57-142, map. [1871.]
227. **Andrews, T.** On the Composition of an Inflammable Gas issuing from below the salt-bed in Belfast. *Proc. Belfast Nat. Hist. Phil. Soc.*, Session 1873-74, pp. 93, 94.
228. **Andrusov, N. I.** [Origin of Petroleum.] *Prot. St. Petersb. Obsch. Estestr.*, 1895, no. 6, pp. 20-22.
229. ——— [Investigation of Karabugas Bay.] *Izv. Imp. Russk. Geogr. Obsch.*, kn. xxxi, pp. 220, 221. [1895.]
230. ——— [Geological Researches in 1901 in the Schemakha District, Bakou.] *Bull. Com. géol. Russ.*, t. xxi, pp. 151-160. [1902.]
231. ——— [Tertiary Deposits of the Schemakha District.] *Bull. Com. géol. Russ.*, t. xxiii, pp. 201-243. [1904.]
232. ——— Geologische Untersuchungen auf der Halbinsel Taman. *Mat. Géol. Russ.*, t. xxi, pp. 256-381, pls. ix-xvi. [1904.]
233. ——— [A Contribution to the Question of the Origin and Position of Sources of Petroleum.] *Trudi Bak. Old. Imp. Russ. Tekhn. Obsch.*, kn. xxi. [1906.]
234. ——— [Origin of Petroleum.] *Revista Petrolului*, t. I, pp. 72-74. [1908.]
235. **Angel, M.** Kern County. 10th *Ann. Rep. State Mineral Calif.* for 1890, pp. 219-226. [1890.]
236. ——— Monterey County. *Ibid.*, pp. 345-348. [1890.]
237. ——— San Luis Obispo County. *Ibid.*, pp. 567-585, pl. [1890.]
238. **Angeli, L. De'** Bollitori di Bergulio e suoi fanghi. 8vo, Imola, 1795.
239. **Angelis d'Ossat, G. d'.** Le sorgenti di petrolio a Tocco da Casauria. *Rass. Min.*, vol. ix. [1899.]
240. ——— Sopra i giacimenti petroliferi della zona neogenica della Rumenia. *Giorn. Géol. Pratt. Genova*, t. I, pp. 69-77. [1903.]
241. ——— Il Miocene nel Versante orientale della Montagna della Majella (Abruzzo). *Boll. Soc. Geol. Ital.*, t. xxv, pp. 656-658. [1906.]
242. **Angelot, V. F.** Recherches sur l'origine du haut degré de salure de divers lacs placés dans le fond de grandes dépressions du sol des continents, et en particulier de la Mer Morte, suivies de considérations sur l'origine du sel gemme en couches. *Bull. Soc. Géol. France*, t. xiv, pp. 356-392. [1843.]
243. **Angenot, C.** Leçons sur le pétrole et ses dérivés données à l'Institut supérieur de commerce. 8vo, Antwerp, 1885.
244. **Angermann, C.** Die Naphtafelder in Wieltrno. *Jahrb. k.-k. geol. Reichsanst.*, bd. xxxix, pp. 281-288. [1889.]
245. ——— Die allgemeine Naphtageologie. Grundlagen zum Studium der Naphtaterraine. 8vo, Vienna, 1900.
246. ——— Ueber Bohrungen in Ungarn und in den Mulden der Petroleumzone Galiziens. *Atta. österr. Chem.-Techn.-Zeit.*, bd. xii, no. 22, [1894.]

247. **Angermann, C.** The Present Method of Petroleum Exploitation, and its Evils. *Petr. Rev.*, vol. iv, p. 393. [1901.]
248. — Notes on the Origin of Petroleum. *Ibid.* vol. v, pp. 275, 276, 301, 302. [1901.]
249. — The Oil-Fields of the Anglo-Russian Maximoff Company, Limited [Grozni]. *Ibid.*, vol. vii, pp. 369-371. [1902.]
250. — Boryslaw in geologisch-tektonischer Hinsicht. *Naphta*, bd. xi, pp. 409-412. [1903.]
251. — Der Allgemeine Raubbau auf Naphta. Ein Beitrag zur Frage der Verwässerung von Naphtaland. *Ibid.*, bd. xii, pp. 3-6. [1904.]
252. — Das Naphthavorkommens von Boryslaw in seinen Beziehungen zum geologisch-tektonischen Bau des Gebietes. *Compt. Rend. Congr. Geol. Internat.*, sess. ix, pp. 767-776, 5 pls. [1904.]
253. **Angerstein, H.** Ueber Mineralöl, Hydrocarbur, Photogen und Paraffin. *Polyt. Journ.*, bd. cxxxvii, pp. 465, 466. [1855.]
254. **Anisimov, —** [On the Taman Oil-Fields.] *Gorn. Journ.*, 1845, t. 4, pp. 349-355.
255. **Ansted, D. T.** The Varieties of Combustible Minerals considered with reference to their geological position and relative value for certain purposes. *Journ. Soc. Arts*, vol. xi, pp. 408-417. [1863.]
256. — On Petroleum Springs in the Eastern Crimea, and on the shores of the Sea of Azof. *Quart. Journ. Sci.*, vol. ii, pp. 755-762. [1865.]
257. — On the Mud Volcanoes of the Crimea, and on the relation of these and similar phenomena to deposits of Petroleum. *Proc. Roy. Inst.*, vol. iv, pp. 628-640. [1866.]
258. **Anstey, H. C.** Liquid Fuel. A new chapter in Ed. ii of English translation of *Chaudières Marines* (L. E. Bertin). 8vo, London, 1906.
259. **Antipov, J. A.** [Dopplerite from Alagule, Moiti district, Sempalatinsk, Siberia.] *Verh. russ.-k. Min. Ges.*, ser. 2, bd. xxviii, pp. 503, 504. [1891.]
260. **Antsill, T.** Geological Report. Part ii. of vol. vii of Reports of Explorations and Surveys to ascertain the most practicable and economical route from the Mississippi River to the Pacific Ocean. 4to, Washington, 1856.
261. — The Manufacture of Photogenic or Hydrocarbon Oils from Coal and other bituminous substances, capable of supplying burning fluids. 8vo, New York, 1859.
262. **Aradi, V.** [Hungarian Petroleum; remarks on recent publications.] *Bányász. Kohász. Lapok*, evf. xxxix, no. 1. [1906.]
263. — [System of work of petroleum-geologists.] *Ibid.*, no. 4.
264. — [Hungarian Petroleum.] *Ibid.*, no. 17.
265. — [Geology of the Bustenari-Campina Oil-belt.] *Ibid.*, evf. xl, köt. 2, pp. 288-293; evf. xli, pp. 166-170, 359-265. [1907.]
266. — [Formation of Rumanian Petroleum.] *Ibid.*, pp. 584-603. [1907.]
267. — Erdöl-Studien. *Allgem. österr. Chem.-Techn.-Zeit.*, bd. xxv, pp. 1, 2, 10-13, 18-20, 27, 28, 43, 44. [1908.]
268. — Salz- und Erdöllagerstätten der Süd- und Ost-karpathen. *Ibid.*, bd. xxvi, pp. 73, 74, 91-93, 115-116. [1908.]
269. — Ueber die Bildung der rumänischen Petroleum lagerstätten. *Org. Ver. Bohrtechn.*, bd. xv, pp. 61-63, 73-75, 102-104, 114, 115, 147-148, 160-162, 174-176, 184, 185, 198, 199, 220-222, 244, 245, 268, 269, 279-281. [1908.]
270. — Entstehung der Petroleumzonen von Rumänien. *Petroleum Zeitschr.*, bd. iv, pp. 730, 731, [1909.]
271. — Eine Tausend-Meter-Sonde in Bustenari. *Ibid.*, pp. 810, 811. [1909.]
272. — Erdölgrube in Ungarn. *Ibid.*, pp. 1115, 1116. [1909.]
273. — Die Erdgase Ungarns. *Org. Ver. Bohrtechn.* bd. xvii, p. 16. [1910.]
274. **Arago, D. F. J.** Extrait du Rapport sur le Voyage de Découvertes exécuté dans les années 1822, 1823, 1824, et 1825, sous le commandement de M. Duperrey, Lieutenant de vaisseau. *Ann. Sci. Nat.*, t. vi, pp. 206-221. [1825.]
275. **Aranzazu, J. M. de.** Apuntes para una descripción físico-geológica de las provincias de Burgos, Logroño, Soria, y Guadaluajara. *Bol. Com. map. geol. Españ.*, t. iv, pp. 1-47; pl. [1877.]
276. **Arata, P. N.** Esquisto Bituminoso de la Provincia de Salta. *An. Soc. Ci. Argent.*, t. iii, pp. 40-44. [1877.]
- Arata, P. N.**, see **Hauthal, R.**
277. **Arboux, A.** Notice sur le Pétrole d'Auvergne. 8vo. Paris, 1890.
278. **Arbel, —, — Danset, A. Henry, and A. Guiselin.** Emplois des Résidus lourds dans l'Industrie. *Compt. Rend. Congr. internat. Pétrole*, sess. 3, t. ii, pp. 813, 814. [1910.]
279. **Archbold, J. D.** The Standard Oil Company: Some Facts and Figures. *Petrol. Rev.*, vol. xviii, pp. 21-25. [1908.]
280. **Archbutt, L.** An Evaporation-Test for Lubricating Oils. *Journ. Soc. Chem. Ind.*, vol. xv, pp. 326-328. [1896.]
281. **Archbutt, L.** and **R. M. Deeley.** Lubrication and Lubricants. 8vo, London, 1900.
282. **Archer, T. C.** On a New Bituminous Substance imported under the name of coal from Brazil. *Proc. R. Soc. Edinb.*, vol. v, pp. 364, 365. [1865.]
283. **Archer, W.** [On a Resinous Powder, washed from the Combustible Schist of the Mersey River, Tasmania.] *Proc. R. Soc. Van Diemen's L.*, vol. ii, p. 511. [1854.]
- Archipov, —**, see **Tselukidze, K.**
284. **Ardagh, J. C.** The Red Sea Petroleum Deposits. *Proc. R. Geogr. Soc.*, vol. viii, pp. 502-507. [1886.]
285. **Ardan, —** Naphtene and Naphtensäuren. *Karlsruhe*, 1910.
286. **Areitio y Larrinaga, A. de.** Descripción de la Dusodila de Hellin. *An. Soc. Españ. Hist. Nat.*, t. ii, pp. 385-387. [1873.]
287. **Arends, H.**, and **C. Mossner.** Handbuch für die Internationale Petroleum-Industrie. *Bertin*, 1911.
288. **Ariosto, F.** De Oleo montis Zibinii seu Petroleo agrí Mutinensis [Modena]. 8vo, Copenhagen, 1669.
289. **Arkannikov, Ph.** [Mt. Gnilaya near Triumuk, Kuban.] *Izv. Imp. Russ. Geogr. Obsch.*, t. xxvi, pp. 100-103. [1890.]
290. — [Mt. Tsimbale, Akhtanisor, Kuban.] *Ibid.*, t. xxvii, pp. 542-546. [1892.]
291. **Armand, H.** [Bituminous Rocks.] *Ann. Mines*, sér. 7, t. x, pp. 464-466. [1876.]
292. **Armstrong, H. E.** On the Manufacture of Gas from Oil. *Journ. Soc. Chem. Ind.*, vol. iii, pp. 462-468. [1884.]
293. — The Mechanics of Fire. *Ibid.*, vol. xxiv, pp. 473-482. [1905.]
294. **Armstrong, H. E.**, and **A. K. Miller.** The Effect of High Temperatures on Petroleum Hydrocarbons. *Chem. News*, vol. xlix, pp. 285, 286. [1884.]
295. — The Decomposition and Genesis of Hydrocarbons at High Temperatures. 1. The products of the manufacture of gas from petroleum. *Journ. Chem. Soc.*, vol. xlix, pp. 74-93. [1886.]
296. **Armstrong, T. H.** The Rocket Oil Engine. *Trans. Inst. Min. Eng.*, vol. x, pp. 473-478, pl. xix. [1896.]
297. **Arnold, R.** The Salt Lake Oil-Field near Los Angeles, Cal. *Bull. U.S. Geol. Surv.*, no. 285, pp. 357-361. [1906.]
298. — New and Characteristic Species of Fossil Molluscs from the Oil-bearing Tertiary Formations of Southern California. *Proc. U.S. Nat. Mus.*, vol. xxxii, pp. 525-546, pls. xxxviii-ii. [1907.]
299. — New and Characteristic Species of Fossil Molluscs from the Oil-bearing Tertiary Formations of Santa Barbara County, California. *Smithson. Miscell. Coll. Quart.*, vol. iv, pp. 419-447, pls. i-iviii. [1907.]

300. **Arnold, R.** The Los Angeles Oil District, Southern California. *Bull. U.S. Geol. Surv.*, no. 309, pp. 138-198, pls. xviii-xxiv. [1907.]
301. ——— Physical and Chemical Properties of Southern California Oils. *Ibid.*, pp. 203-205. [1907.]
302. ——— Fossils of the Oil-bearing Formations of Southern California. *Ibid.*, pp. 219-256, pls. xxv-xli. [1907.]
303. ——— Geology and Oil Resources of the Summerland District, Santa Barbara County, California. *Ibid.*, no. 321. Pp. 91, 20 pls. [1907.]
304. ——— The Miner Ranch Oil-Field, Contra Costa County, Cal. *Ibid.*, no. 340, pp. 339-342. [1903.]
305. ——— The Santa Maria Oil District (California, U.S.A.). *Compt. Rend. Congr. internat. Pétrole*, sess. 3, t. II, pp. 365-380. [1910.]
306. ——— Metamorphism by Combustion of the Hydrocarbons in the Oil-bearing Shale of California. *Journ. Geol.*, vol. xv, pp. 750-758. [1907.]
307. **Arnold, R., and Robert Anderson.** Preliminary Report on the Santa Maria Oil District, Santa Barbara County, California. *Bull. U.S. Geol. Surv.*, no. 317. Pp. 69, 2 pls. [1907]; no. 329. Pp. 161, 26 pls. [1907.]
308. ———, ———. Preliminary Report on the Coalinga Oil District, Fresno and Kings Counties, California. *Bull. U.S. Geol. Surv.*, no. 357. Pp. 142, 3 maps. [1908.]
309. **Arnold, R., Robert Anderson, and I. C. Allen.** Geology and Oil Resources of the Coalinga District, California, with a Report on the Chemical and Physical Properties of the Oils. *Ibid.*, no. 398. Pp. 353, 30 pls. (xxiii-lii), 12 maps. [1910.]
310. **Arnold, R., and H. R. Johnson.** Preliminary Report on the McKittrick-Sunset Oil Region, Kern and San Luis Obispo Counties, California. *Ibid.*, no. 406. Pp. 225, 4 pls. [1910.]
- Arnold, R., see Branner, J. C., and Eldridge, G. H.**
311. **Aron, A.** L'Exploitation du Pétrole en Roumanie. *Ann. Mines*, sér. 10, t. VII, pp. 380-464. [1905.]
312. ——— Note sur l'Industrie française des Schistes bitumineux. *Ibid.*, t. IX, pp. 47-75. [1906.]
313. ——— Le Pétrole de Roumanie, et le Congrès de Bucharest. *Ibid.*, t. XIII, pp. 27-109, pl. I. [1908.]
314. **Arragon, C.** Ueber eine neue Farbenreaktion des Petroleums. *Chem.-Zeit.*, bd. xxxiii, pp. 20, 21. [1909.]
315. **Arth, G.** Sur la Détermination du Pouvoir calorifique des gaz de hauts fourneaux par l'obus calorimétrique. *Bull. Soc. Chim. Paris*, sér. 3, t. xxxi, pp. 576-578. [1904.]
316. **Artus, W.** Neue Anwendung des Mineralöls zum Einölen der Uhren und anderer metallenen Geräthschaften. *Vierteljahrschr. techn. Chem.*, bd. I, p. 39. [1853.]
317. **Aschan, O.** Ueber die in dem Erdöl aus Baku vorkommenden Säuren von niedrigerem Kohlenstoffgehalt. *Ber. deutsch. chem. Ges.*, bd. xxiii, pp. 867-875; bd. xxiv, pp. 2710-2724; bd. xxv, pp. 3661-3670. [1890-1892.]
318. ——— Ueber die Natur der Naphtene des russischen Petroleums. *Chem.-Zeit.*, bd. xxi, pp. 242, 287, 288. [1897.]
319. ——— Nachweis von Diisopropyl im Petroleumäther aus Baku. *Ber. deutsch. chem. Ges.*, bd. xxxi, pp. 1801-1803. [1898.]
320. ——— Ueber das Vorkommen von Methyl-pentamethylen in kaukasischen Petroleumäther. *Ibid.*, pp. 1803-1806. [1898.]
321. ——— Ueber die Bildung der Adipinsäure aus der um 80° siedenden Naphtenfraction des russischen Petroleumäthers. *Ibid.*, bd. xxxii, pp. 1769-1772. [1899.]
322. ——— Zur Genese der Naphtene und der Naphtensäuren. *Ann. Chem. Pharm.*, bd. cccxxiv, pp. 1-39. [1902.]
323. ——— Petrolsäuren oder Naphtensäuren? *Chem. Zeit.*, bd. xxxii, p. 729. [1908.]
324. **Ascher, F.** Petroleumindustrie. *Allg. österr. Chem.-Techn.-Zeit.*, bd. I, 1883.
325. **Ascher, F.** Das Gebiet des ewigen Feuers in Siebenbürgen. *Allg. österr. Chem.-Techn.-Zeit.*, bd. v. [1887.]
326. **Ashburner, C. A.** Description of the Wilcox Sponting Water Well. *Proc. Amer. Phil. Soc.*, vol. xvii, pp. 127-135, pl. III. [1878.]
327. ——— Oil Well Records in McKean and Elk Counties, Pennsylvania. *Ibid.*, vol. xviii, pp. 9-26. [1878.]
328. ——— The Oil Sands of Pennsylvania. *Journ. Franklin Inst.*, vol. cv, pp. 225-233. [1878.]
329. ——— The Bradford Oil District of Pennsylvania. *Trans. Amer. Inst. Min. Eng.*, vol. II, pp. 316-328, pl. VII. [1879.]
330. ——— The Kane Geyser Well. *Journ. Franklin Inst.*, vol. cviii, p. 347. [1879.]
331. ——— On the Constitution of the Bradford Oil Sand. *Proc. Amer. Phil. Soc.*, vol. xviii, pp. 419-422. [1880.]
332. ——— Petroleum. *Amer. Journ.*, ser. 3, vol. xix, p. 168. [1880.]
333. ——— The Geology of McKean County, and its connection with that of Cameron, Elk, and Forst. *2nd Geol. Surv. Penns.*, R. 8vo, Harrisburg, 1880.
334. ——— New Map of Northern Oil Field. *Philadelphia*, 1881.
335. ——— The Geology of Natural Gas. *Science* [ser. 1], vol. VI, pp. 42, 43, 184, 185. [1885.]
336. ——— Borings for Oil in Jackson and Abbot Townships, Potter County [Pa.]. *Ann. Rep. Geol. Surv. Penns.*, 1885, pp. 82-94. [1885.]
337. ——— The Product and Exhaustion of the Oil Regions of Pennsylvania and New York. *Trans. Amer. Inst. Min. Eng.*, vol. xiv, pp. 419-428, 2 pls. [1886.]
338. ——— The Geology of Natural Gas in Pennsylvania and New York. *Ibid.*, vol. xiv, pp. 428-438, map. [1886.]
339. ——— The Geologic Distribution of Natural Gas in the United States. *Ibid.*, vol. xv, pp. 505-542, 2 pls. and map. [1887.]
340. ——— Natural Gas in New York. *Amer. Manuf. Nat. Gas Suppl.*, 1887 *Min. Res. U. States*, 1887, pp. 474-479. [1888.]
341. ——— Petroleum and Natural Gas in New York State. *Trans. Amer. Inst. Min. Eng.*, vol. xvi, pp. 906-959, map, 2 pls. [1888.]
342. ——— Geology of Buffalo as related to Natural Gas Explorations along Niagara River. *Ibid.*, vol. xvii, pp. 398-406. [1889.]
343. ——— Natural Gas Explorations in the Eastern Ontario Peninsula. *Trans. Amer. Inst. Min. Eng.*, vol. xviii, pp. 290-303. [1890.]
344. **Ashburner, C. A., and A. W. Sheaffer.** The Township Geology of Elk and Forest Counties, and of Cameron County. *2nd Geol. Surv. Penns.*, R 2, pt. 2. 8vo, Harrisburg, 1885.
345. **Asheroff, A. G.** Experiments on a Method of Measuring the Air- or Gas-Supply to Engines and Furnaces. *Proc. Inst. Civ. Eng.*, vol. cixiii, pp. 289-297. [1908.]
346. **Ashley, G. H.** Outline introduction to the mineral resources of Tennessee. *Bull. Geol. Surv. Tennessee*, no. 2A. Pp. 65. [1910.]
- Ashley, G. H., see Fuller, M. L.**
347. **Ashworth, J.** Outbursts of Gas and Coal at the Morrissey Collieries, British Columbia. *Trans. Manch. Geol. Soc.*, vol. xxix, pp. 66-76, pl. III. [1905.]
348. **Asperti, —.** Analisi chimica dell'acqua delle saline di Salsomaggiore nella provincia di Parma. *Ann. Chim. Ital.*, t. liii, pp. 125-128. [1871.]
349. **Aström, C. G.** Om Bergoljaorrningarne i Dalarna. [1869.]
350. **Athanasiu, E.** Esquisse géologique des régions pétrolifères des Carpatés du district de Bacau. 8vo, Bucharest, 1907.
351. **Athanasiu, S.** Geologische Studien in den nord-moldauischen Karpathen. *Jahrb. k.-k. geol. Reichs.*, bd. xlix, pp. 429-492. [1899.]
352. **Atkinson, A. A.** Reports of Chief Inspector of Coal and [Kerosene] Shale Mines. *Ann. Rep. Dep. Mines N.S. Wales*, 1897-1910. [1898-1911.]

- Atkinson, E., see Ordway, J. M.
363. **Atkinson, J. A.** A Locality List of all the Minerals hitherto recorded from Victoria. *Proc. Roy. Soc. Victoria*, n.s., vol. ix, pp. 68-119. [1897.]
354. **Atfield, J.** On the Assay of Coal, etc., for crude paraffin oil, and of crude Oil and Petroleum for Spirit, Photogen, Lubricating Oil and Paraffine. *Pharm. Journ.*, ser. 2, vol. viii, pp. 159-163. [1867.]
355. — On the Cause of Explosions in Lamps. *Ibid.*, pp. 378-381. [1867.]
356. — On the Igniting Point of Petroleum. *Ibid.*, pp. 318-325. [1867]; ser. 3, vol. ii, p. 43. [1871.]
357. — The Relation of Mineral Oils to Fire. *Ibid.*, ser. 3, vol. ii, p. 346. [1871.]
358. **Attman, J.** Bergöhl in Galizien. *Verh. k.-k. geol. Reichs.*, 1877, p. 72.
359. **Atwater, W. O., and J. F. Snell.** Description of a Bomb-Calorimeter, and Method of its Use. *Journ. Amer. Chem. Soc.*, vol. xxv, pp. 659-699. [1903.]
360. **Aubury, L. E.** Mineral Production of California. *Bull. Calif. State Min. Bureau*, no. 53. [1907.]
361. — Protection of Oil and Gas Strata. *Ibid.*, no. 56, pp. 76, 77. [1909.]
362. — Map of Mineral Deposits, California. *Calif. State Min. Bureau*, Dec. 1910.
363. — Fake Oil Companies. *Mines and Minerals*, vol. xxxi, p. 424. [1911.]
364. **Audouin, P.** Application des hydrocarbures liquides (pétrole, goudron, huile lourde), à l'obtention des hautes températures et au chauffage des machines à vapeur. *Ann. Chim. Phys.*, sér. 4, t. xv, pp. 30-40, pl. II. [1868.]
365. **Auerbach, A.** [Two Self-Rotating Free-Fall Instruments for Canadian Boring.] *Gorn. Journ.*, 1869, t. 4, pp. 29-39.
366. **Aufrecht, —.** [Estimation of Sulphur in Petroleum.] *Pharm. Zeit.*, bd. xii, p. 469. [1896.]
367. **Aufschlager, —.** Das Elsass. *Strassburg* 1825.
368. **Augehey, S.** Preliminary Report on the Wyoming Oil Springs. *Omaha*, 1881.
369. — Report on Wyoming Oil Springs. 4to, *Omaha*, 1882.
370. — Annual Report of Territorial Geologist to the Governor of Wyoming, 1885. 8vo, *Washington*, 1886.
371. — Annual Report of the Territorial Geologist to the Governor of Wyoming, 1886. Svo. *Laramie*, 1886.
372. **Austen, R. M.** Report on the Oil Industry of Echigo (Japan). *Dipl. Cons. Rep.*, miscell. ser., no. 679. [1911.]
373. **Austia, E.** The Internal Combustion Engine and Petroleum: a Criticism and a Suggestion. *Petrol. Rev.*, vol. vii, pp. 445, 473. [1902.]
374. **Austin, K.** Mining Locomotives and Liquid Fuel: Their Probable Influence on the South African Labor Problem. *Journ. Transvaal Inst. Mech. Eng.*, vol. ix, no. 1. [1910.]
375. **Ave-Lallemaut, G.** Estudios mineros en la Provincia de Mendoza. La pente septentrional de la Sierra de Uspallata. *Bol. Ac. Nac. Ci. Cordoba*, t. xii, pp. 131-176; 3 pls. [1892.]
376. **Averill, P.** Report of State Inspector. 5th Ann. Rep. *Michigan Board of Health*. *Lansing*, 1877.
377. **Aydon, H.** Liquid Fuels. *Proc. Inst. Civ. Eng.*, vol. lii, pp. 177-213. [1878.]
378. **Aymard, —.** Le Boghead d'Aulun. *Compt. Rend. Soc. Ind. Min.*, 1880, pp. 171-176. [1880.]
379. **Ayres, A.** Compressed Oil-gas and its Applications. *Proc. Inst. Civ. Eng.*, vol. xciii, pp. 298-263. [1888.]
380. **Azantchev, U.** Mineral Statistics of Russia. 8vo, *St. Petersburg*, 1894.
381. **B—.** Storage of Petroleum, Benzene or Similar Substances while on draught for sale or use. *Journ. Franklin Inst.*, vol. ci, pp. 224, 225. [1876.]
382. **B—.** A. [Asphalt Pavements.] *Inf. Journ*, 1871, pp. 290-293.
383. **B—.** A. [Naphtha Deposits in Italy.] *Trudi Bak. Obi. Imp. Russk. Tekhn. Obsch.*, July-Aug. 1893, pp. 58-66.
384. — [Peruvian Oil.] *Allg. österr. Chem.-tech.-Zeit.*, bd. xi. [1893.]
385. — [Ozokerite and its transformation into Ceresine.] *Trudi Bak. Obi. Imp. Russk. Tekhn. Obsch.*, 1893, Nov.-Dec., pp. 49-98.
386. **B—.** C. Estratto di una Memoria manoscritta sul Petrolio, e sugli usi economici del medesimo. *Giorn. Soc. Incorr. Milán*, t. v, pp. 255-290. [1809.]
387. **B—.** E. Mittheilungen aus dem russischen Petroleum-Eldorado. *Das Ausland*, 1836, pp. 624-629.
388. **B—.** P. La Question du Pétrôle et des Huiles minérales. *Corps Gras Industr.*, ann. vi, pp. 25-27, 37, 38. [1879.]
389. **B—.** S. R. The Economic Lubrication of Moving Surfaces. *Petrol. World*, vol. v, p. 311. [1908.]
390. **Babst, A.** Das Baku'sche Petroleum. *Riga Industr. Zeit.*, 1878, no. 14, p. 163.
391. **Babu, L.** Note sur l'Ozokerite de Boryslaw et les Pétrôles de Sloboda [Gallicie]. *Ann. Mines*, sér. 8, t. xiv, pp. 162-196. [1888.]
392. **Bach, O.** Ueber die Prüfung der Maschinenschmieröle. *Chem.-Zeit.*, bd. xiii, pp. 905, 906. [1889.]
393. **Back, G.** Account of the route to be pursued by the Arctic land expedition in search of Captain Ross. *Journ. R. Geogr. Soc.*, vol. liii, pp. 64-71. [1833.]
394. **Badeau, A.** Asphalt and Asphalt Trade of Cuba. *Rep. Cons. U.S.*, vol. x, pp. 71-76. [1833.]
395. **Baer, K. E. v.** Kaspische Studien. *Bull. Ac. Imp. Sci. St. Pétersb.*, t. xv, pp. 177-202. [1857.]
396. **Baern, —.** [Construction-Materials of Caucasia and Transcaucasia.] *Zap. Kavk. Otd. Russk. Tekhn. Obsch.*, t. v. [1873.]
397. **Bailey, E. H. S.** Miscellaneous Chemical Notes. *Trans. Kansas Ac. Sci.*, vol. x, pp. 62, 63. [1887.]
398. — Natural Gas and Coal Oil in Kansas. *Kansas Univ. Quart.*, vol. iv, pp. 1-14. [1895.]
399. — Composition of Natural Gas. *Nat. - Gas Journ.*, vol. i, no. 3, p. 3. [1907.]
400. **Bailey, G. E.** Petroleum in Wyoming. 1887.
401. **Bailey, L. W.** Report on the Mines and Minerals of New Brunswick. *Fredericton*, 1864.
402. — Observations on the Geology of Southern New Brunswick. *Fredericton*, 1865.
403. — The Mineral Resources of the Province of New Brunswick. *Ann. Rep. Geol. Surv. Canada*, n.s., vol. x, report M. Pp. 129, 2 pls., and map 1: 633,600. 1899.
404. — On some Modes of Occurrence of the Mineral Albertite. *Trans. Roy. Soc. Canada*, ser. 2, vol. vii, sect. iv, pp. 77-83, pl. [1901.]
405. **Bailey, L. W., and R. W. Ellis.** Report on the Lower Carboniferous Belt of Albert and Westmorland counties, New Brunswick, including the "Albert Shales." *Rep. Geol. Surv. Canada*, 1876-1877, pp. 351-401.
406. **Bailey, L. W., and G. F. Mathew.** Preliminary Report on Geology of Southern New Brunswick. *Ibid.*, 1870-1871, pp. 13-240.
407. **Bailey, L. W., G. F. Mathew, and R. W. Ellis.** Report on the Geology of Southern New Brunswick, embracing the Counties of Charlotte, Queen's, King's, St John, and Albert. *Ibid.*, 1878-1879, D. Pp. iv, 26, map, 6 pls. [1880.]
408. **Baillie, G. H.** Petrol testing. *Engineer*, vol. cv, p. 540. [1908.]
409. **Bailly, —.** Voyage de Découvertes aux Terres Australes, 1800-1804. *Paris*, 1807.
410. **Bain, H. F.** Geology of Polk County [Iowa]. *Rep. Iowa Geol. Surv.*, vol. vii, pp. 263-412, pls. vii-ix. [1897.]
411. — Geology of Guthrie County, Iowa. *Ibid.*, pp. 413-487. [1897.]
412. — The South-eastern Illinois Oil Field. *Min. Sci. Press*, vol. xcii, p. 326. [1906.]

413. **Bain, H. F.** Petroleum in Illinois. *Min. Ind.*, vol. xv, pp. 620-623. [1907.]
414. ——— The Mineral Industry in 1906. *Illinois Geol. Surv. Bull.*, no. 4, pp. 245, 246. [1907.]
415. ——— Petroleum Fields of Illinois in 1907. *Ibid.*, no. 8, pp. 273-312, pl. [1908.]
416. ——— The Mineral Industry of Illinois. *Ibid.*, pp. 373, 374. [1908.]
417. ——— Some recent literature on Petroleum. *Econ. Geol.*, vol. iii, pp. 231-246. [1908.]
418. ——— Geology of Illinois Petroleum Fields. *Ibid.*, vol. iii, pp. 481-491, pl. ix. [1908.]
419. ——— Petroleum Fields of Illinois. *Min. Sci. Press*, vol. xcix, pp. 153-156. [1909.]
420. **Baisdenko, N.** Therapeutic Applications of Petroleum. *Petrol. Rev.*, vol. ix, p. 229. [1903.]
421. **Baker, A.** Report on the Mines and Minerals of the State of Vera Cruz. *Dipl. Cons. Rep.*, miscell. ser., no. 66. [1887.]
422. ——— Report for the year 1887 on the Trade of Vera Cruz. *Ibid.*, ann. ser., no. 322. [1888.]
423. **Baker, E. L.** Petroleum Deposits in the Argentine Republic. *Rep. Cons. U.S.*, vol. vi, pp. 11, 12. [1882.]
424. **Baker, G.** Journal of an Embassy to the King of Burma in 1755. *Orient. Rep.*, 1791.
425. **Baker, O. H.** Australian Kerosene Shale. Preparation being made to work the New South Wales Deposits. *U.S. Cons. Rep.*, no. 333, pp. 107, 108. [1908.]
426. **Bakhtmetev, A. P.** [Batum and Poti in relation to the Caucasian Oil Industry.] *Zap. Kark. Od. Russk. Tekhn. Obsch.*, t. xiii, pp. 214-229. [1881.]
427. **Balbano, L.** Ricerche sul petroli italiani. *Gazz. Chim. Ital.*, t. xxxii, pt. 1, pp. 437-447. [1902.]
428. **Balbano, L.** and **V. Paolini.** Ueber die Analyse von Petroleumäthern. *Chem.-Zeit.*, bd. xxv, pp. 932, 933. [1901.]
429. ———, ———, Sull'analisi degli eteri di petrolio. *Gazz. Chim. Ital.*, t. xxxvi, pp. 251-256. [1908.]
430. **Balbano, L.** and **P. Zeppa.** Ricerche sul petroli italiani. *Ibid.*, t. xxxiii, pt. 2, pp. 42-50. [1903.]
431. **Baldacci, L.** Descrizione geologica dell'isola di Sicilia. *Mem. Cart. Geol. Ital.*, t. 1, pp. xxxii, 408, 2 maps, 10 pls. 8vo, Rome, 1886.
432. **Bale, M. P.** Gas and Oil Engine Management. London, 1904.
433. **Balkwill, F. H.** The Sacred Fire of Israel. *Nineteenth Century*, vol. ix, pp. 277-288. [1906.]
434. **Ball, L. C.** Petroleum in Queensland. *Queensland Govt. Min. Journ.*, Aug. 15, 1910.
435. **Ball, S. H.** The Tampico Oilfield, Mexico. *Eng. Min. Journ.*, vol. xci, pp. 959-961. [1911.]
436. **Ball, V.** On the Building and Ornamental Stones of India. *Rec. Geol. Surv. Ind.*, vol. vii, pp. 98-122. [1874.]
437. ——— The Mineral Resources of India and their Development. *Journ. Soc. Arts*, vol. xxx, p. 595. [1882.]
- Ball, V.**, see **Medlicott, H. B.**
438. **Ballantyne, H.** Exhaust Gases from Motors. *Proc. Inst. Automob. Eng.*, n.s., vol. ii, pp. 101, 102. [1907.]
439. ——— Some Chemical Notes on Petrol. *Proc. Inst. Automob. Eng.*, n.s., vol. iii, pp. 294-300. [1909.]
440. **Balsamo-Crivelli, G.** and **L. Maggi.** Relazione sulle miniere petrolifere di Rivanasciano. *Milan*, 1871.
441. **Balukевич.** — [Domestic Oil-stoves.] *Zap. Kavk. Od. Imp. Russk. Tekhn. Obsch.*, t. xv, pt. 1. [1883.]
442. **Bamberger, E.** Ueber den Fichtelit. *Ber. deutsch. chem. Ges.*, bd. xxii, pp. 636-637. [1889.]
443. **Bamberger, E.** and **L. Strasser.** Ueber den Fichtelit. *Ibid.*, pp. 3361-3368. [1889.]
444. **Bancroft.** — The Pacific States of North America. *San Francisco*, 1882-1891.
445. **Bandrowski, F. X.** Ueber das Vorkommen alkaloid-artiger Basen im galizischen Roheröl. *Monatsh. Chem.*, bd. viii, pp. 234-226. [1887.]
- Bannan, B.**, see **Daddow, S.**
446. **Bannister, L.** Something about Natural Gas: its Origin, Extent, and Development. 8vo, *New York*, 1886.
447. **Baratta, M.** A proposito dei "Mistpoeffers" Italiani. *Boll. Soc. Geogr. Ital.*, ser. 4, vol. ii, pp. 882-893. [1901.]
448. **Barba, A. A.** [Of the Art of Metals and their Generation (Spanish)]. 4to, *Madrid*, 1640.
449. **Barbet, E.** Rectification Continue et Classification des Hydrocarbures. *Compt. Rend. Congr. internat. Chim. appl.*, sess. 7, t. iv, p. 18. [1910.]
450. **Barbot de Marni, N. N.** [Comparative Sketch of the Naphtha Localities of the Caspian Littoral.] *Mat. Geol. Kark.*, ser. 2, kn. vi, pp. 289-325, map and sections. [1892.]
451. ——— [Oil-fields of North Caucasus.] *Izv. Obsch. Gorn. Inzen.*, kn. ii, pp. 1-14. [1893.]
452. ——— [Geological Researches in the Temir-Khanshura District, Daghestan.] *Mat. Geol. Kark.*, ser. 2, kn. viii, pp. 223-409, map and sections. [1894.]
453. ——— [Mineral Wealth of Daghestan. Pt. I., N.-W. Daghestan.] *Ibid.*, ser. 2, kn. ix, pp. 229-286, map of N.W. Daghestan, 1:210,000, and sections. [1895.]
454. **Barbot de Marni, N. N.**, and **S. Simonovitch.** [Geological Description of the Binagadi Oil Field, Apscheron Peninsula.] *Ibid.*, ser. 2, kn. v, pp. 1-245; 4 maps, 3 pls. [1891.]
455. **Barbour, E. H.** Report of the State Geologist [of Nebraska]. *Nebraska Geol. Surv.*, vol. 1. Pp. 258. 8vo, *Lincoln, Neb.*, 1903.
456. **Barbour, G. E.** The Los Angeles Oil industry. *Eng. Min. Journ.*, vol. lxxxviii, pp. 365, 366. [1909.]
457. ——— Utah. *Ibid.*, vol. lxxxix, pp. 88-92. [1910.]
458. **Barclay, G.** Report for the years 1903 and 1904 on the Trade of Japan. *Dipl. Cons. Rep.*, ann. ser., nos. 3212 and 3377. [1904, 1905.]
459. **Bardy, C.** L'Industrie du Pétrole à l'Exposition Universelle de 1889. *Rev. techn. Exp. Univ.* 1889, t. i, pt. xi.
460. **Barentin, W.** Ueber das Anströmen brennbarer Gase. *Ann. Phys. Chem.*, bd. cvii, pp. 183-186. [1859.]
461. **Barf, A.** Petroleum as Fuel. *Journ. Soc. Arts*, vol. xxviii, pp. 761, 811, 812. [1880.]
- Barishac, N.**, see **Boyer, E.**
462. **Barlow, A. E.** Report on the Origin, Geological Relations, and Composition of the Nickel and Copper Deposits of the Sudbury Mining District, Ontario. *Ann. Rep. Geol. Surv. Canada*, n.s., vol. xiv, II, pp. 236; 23 pls., 5 maps. [1905.]
463. **Barlow, C.** The Kern County Oil-fields [California]. *Petrol. Rev.*, vol. vi, pp. 16, 17. [1902.]
464. **Barlow, J.** On Mineral Candles and other products manufactured at Belmont and Sherwood. *Proc. Roy. Inst.*, vol. ii, pp. 506-508. [1858.]
465. **Barnard, J. G.**, and **J. G. Williams.** The Isthmus of Tehuantepec. 8vo, *New York*, 1852.
466. **Barois, J.** Rapport sur la Recherche du Pétrole de la Mer Rouge. Pp. 16. *Geol. Surv. Egypt*, 1885.
467. ——— Note sur le Pétrole de la Mer Rouge. *Bull. Inst. Khédiv. Egypte*, sér. 2, no. 7, pp. 90-101. [1887.]
468. **Baron, E.** Le monopole du raffinage des pétroles par l'Etat. *Rev. Chim. Ind.*, ann. xv, pp. 131-135. [1904.]
469. **Baron, R.** Notes on the Geology of Madagascar. *Quart. Journ. Geol. Soc.*, vol. xiv, pp. 305-339, pls. xiii, xiv. [1889.]
470. **Barran, d'A. de.** [On M. Granler's Process for Lowering the Flash-point of Mineral Oils.] *Compt. Rend.*, t. lxxviii, pp. 490-492. [1871.]
471. **Barrande, J.** Bemerkungen über die Abhandlung des Hrn. Ed. Sness: "Ueber böhmische Graptolithen." *Jahrb. k.-t. geol. Reichs.*, bd. iii, h. 2, pp. 139-155. [1852.]

472. **Barrande, J.** Remplissage organique du siphon dans certains Cephalopodes paléozoïques. *Bull. Soc. Géol. France*, sér. 2, t. xii, pp. 441-488. [1855.]
473. ——— Dépôt organique dans les loges aériennes des Orthocères. *Ibid.*, sér. 2, t. xvi, pp. 825-856, pl. [1859.]
474. **Barrat, M.** Sur la Géologie du Congo français. *Ann. Mines*, sér. 9, t. vii, Mém. pp. 379-510. [1895.]
475. **Barret, —.** Note sur la combustion des huiles et essences de pétrole. *Ann. Gén. Civ.*, t. liii, pp. 1-10, 150-161, 217-230. [1874.]
476. **Barrier, E. A.** Flash, Fire and Explosion Tests on Mixtures of Carbon Tetrachloride and Naphtha. *Journ. Ind. Eng. Chem.*, vol. ii, pp. 16-19. [1910.]
477. **Barriga, M. D.** Mining in Mexico. *Mining Journ.*, vol. lxxviii, pp. 3, 38, 39. [1905.]
478. **Barron, T., and W. F. Hume.** Topography and Geology of the Eastern Desert of Egypt, Central Portion. *Geol. Surv. Egypt*, 1902.
479. **Barroso, A.** Memoria sobre la geología del Istmo de Tehuantepec. *An. Ministr. Foment. Mexic.*, t. liii, pp. 245-330; geol. map, 1:500,000. [1880.]
480. **Barrows, G. S.** The Use of Natural Gas as an Illuminant. *Nat.-Gas Journ.*, vol. v, No. 6, pp. 30-32. [1911.]
481. **Barruel, M. P.** Sur le Point de Solidification des Paraffines. *Monit. Scient.*, t. liii, p. 173. [1899.]
482. **Barry, J. G.** The Dottedene Gas Field. *Bienn. Rep. Geol. Surv. N. Dakota*, vol. v, pp. 245-251, pl. [1909.]
483. **Barta, L.** Zur Bestimmung des Erweichungspunktes von Asphalt. *Petroleum Zeitschr.*, bd. vii, pp. 158, 159. [1911.]
484. **Bartel, E.** Die Erdöl-Bergbaue in Pasticzna (Galizien). *Montan.-Zeit. Oesterr. Ung. Balk.*, bd. iv, p. 27. [1897.]
485. ——— Ungarische Petroleumterrains. Der Erdölbergbau in Körösmező. *Allg. österr. Chem.-Techn.-Zeit.*, bd. xv, no. 8. [1897.]
486. ——— Die Erdölbohrungen in Körösmező. *Ibid.*, bd. xvi, no. 5. [1898.]
487. ——— Die Malkoper Erdölindustrie. *Org. Ver. Bohrtechn.*, bd. xviii, pp. 61, 62, 261, 262. [1911.]
- Barth, A.**, see **Janke, L.**
488. **Barthel, G.** Dochtloser Benzinbrenner. *Ber. deutsch. chem. Ges.*, bd. xxvi, pp. 1179, 1180. [1893.]
489. **Bartholdi, G. C.** Mémoire sur la nature chimique des échantillons de mines trouvés dans les environs d'Hirsingue, arrond. Altkirch. *Proc.-verb. Soc. Emul. Colmar*, 1803.
490. **Bartleman, R. M.** Petroleum in Argentina. *U.S. Cons. Rep.* [1911.]
491. **Bartlett, C. H.** Asphaltic Oil Treatment of Macadam Roads. *Journ. Assoc. Eng. Soc.*, vol. xlv, pp. 125-134. [1910.]
492. **Bartoli, A.** Relazione fra la Coesione Specifica, la Densità e il Calorico Specifico di una classe di liquidi. *Nuovo Cimento*, sér. 3, t. vi, pp. 141-149. [1879.]
493. **Bartoli, A., and E. Stracciati.** Le temperature critiche e i volumi molecolari ai gradi critici per gli idrocarburi  $C_nH_{2n+2}$  dei petroli di Pensilvania. *Gazz. Chim. Ital.*, vol. xiv, pp. 548-553. [1884.]
494. ——— La proprietà fisica degli idrocarburi  $C_nH_{2n+2}$  dei petroli. *Atti. R. Acc. Linc.*, sér. 3, vol. xix, pp. 643-671. [1884.]
495. ——— La proprietà fisica degli idrocarburi  $C_nH_{2n+2}$  dei petroli di Pensilvania. *Gazz. Chim. Ital.*, t. xv, pp. 417-446. [1886.]
496. **Bartolotti, P.** Apparechio di laboratorio per la preparazione del gas col petroli leggeri. *Ibid.*, vol. xvii, pt. ii, pp. 335-347. [1897.]
497. **Bartonec, F.** Ergebnisse der vom k.-k. Ackerbauministerium im Jahre 1902 eingesetzten Kommission zur Untersuchung der Betriebsverhältnisse der Erdwachsbergbaues in Galizien. *Vienna*, 1903.
498. **Bartoszewicz, S.** Spiritus und Petroleum als Erzeuger von Licht und Kraft, und einiges über Motoren. *Naphtha*, bd. xii, pp. 230-232, 262-264. [1904.]
499. ——— Die Bestenung der Petroleumindustrie. *Ibid.*, bd. xv, pp. 85-87, 104-107. [1907.]
500. **Bartoszewicz, S.** Die wirtschaftliche Lage der galizische Petroleumindustrie. *Naphtha*, bd. xv, pp. 322-326. [1907.]
501. ——— Die Petroleumverbrauchs Steuer. *Ibid.*, bd. xvi, pp. 83-87. [1908.]
502. ——— Die wirtschaftliche Lage der galizischen Petroleumindustrie. *Compt. Rend. Congr. internat. Pétrole*, sess. 3, t. ii, pp. 847-852. [1910.]
- Bartoszewicz, W.**, see **Gruszkiewicz, J.**
503. **Bartow, E., and E. V. McCollum.** Some Kansas Petroleum. *Trans. Kansas Acad. Sci.*, vol. xviii, pp. 57, 58. [1903.]
504. ——— Kansas Petroleum. *Ibid.*, vol. xix, pp. 56-59. [1905.]
505. **Baskakow, L. L.** Sur l'Origine Secondaire des Gisements de Pétrole. *Compt. Rend. Congr. internat. Pétrole*, sess. 3, t. ii, pp. 171-178. [1910.]
506. **Baskerville, C.** Economic Possibilities of American Oil Shales. *Eng. Min. Journ.*, vol. lxxxviii, pp. 149-154, 195-199. [1909.]
507. ——— Oil Shales of Canada. *Compt. Rend. Congr. internat. Chim. Appl.*, sess. 7, t. iv, pp. 22-31. [1910.]
508. **Baskerville, C., and W. A. Hamor.** Oil Shales of America. *Journ. Ind. Eng. Chem.*, vol. i, pp. 507-511. [1909.]
509. **Bassani, F.** Sui fossili e sull'età degli schisti bituminosi triasici di Besano in Lombardia. *Atti Soc. Ital. Sci. Nat.*, vol. xxix, pp. 15-72. [1886.]
510. **Bates, L. T.** Oil-fields of Peru. *Yale Sci. Monthly*, March 1910.
511. **Batsévitch, L.** [Baku in its topographical and hydrographical aspects.] *Zap. Kavk. Old. Imp. Russk. Tekhn. Obsch.*, 1869-70, t. ii, pp. 19-22.
512. ——— [Geological Description of the Signakh District, Tiflis Government.] *Mat. Geol. Kavk.*, 1878, pp. 1-48, map.
513. ——— [Contributions to the Knowledge of the Oil-fields of the Apsheron Peninsula. Pt. I., with an Appendix: A digest of the grants for wells sunk within the limits of the naphtha valleys up to 1850, inclusive.] *Ibid.*, 1881, pp. 71, xiii; 2 maps, 3 pls.
514. ——— [Geological Description of the Bibi-Eibat Oil-bearing Ravine on the Apsheron Peninsula.] *Ibid.*, 1884, map and section.
515. ——— [Apsheron Peninsula.] *Ibid.*, 1885, pp. 1-26.
516. ——— [Geological Researches in the Batum District.] *Ibid.*, 1885, pp. 27. [1885.]
517. ——— [Sakhalin Oil Deposits.] *Gorn. Journ.*, 1890, t. 3, pp. 129-155.
518. ——— [Materials for the Study of Amurland in regard to Geological and Mining Conditions.] *Svo. St. Petersburg*, 1894.
519. **Batty, W.** [Petroleum Residues as Fuel for Smelting Furnaces.] *Polyt. Review*, 1876, p. 51.
520. **Baudin, — (1).** Codex Bandinus. [Travels in Moldavia, 1644-1646.] *An. Acad. Rom.*, t. xvi. [1895.]
521. **Baudin, — (2).** Résultats principaux des expériences faites dans le laboratoire de chimie de Clermont, pendant l'année 1837 (et 1838). *Ann. Mines*, sér. 3, t. xiv, pp. 291-293; t. xvi, pp. 482-485. [1838, 1839.]
522. **Baudry de Saunier, L.** L'Automobile, etc. i. Motocycles et Voitures à pétrole. ii. Voitures à pétrole. 2<sup>e</sup> Pt. *Svo. Neuilly-Levallois*, 1899, 1900.
523. ——— Manuel pratique de la Bicyclette . . . Bicyclettes à pétrole. *Svo. Paris*, 19 .
524. ——— L'Allumage dans les Moteurs à Explosions. *Svo. Paris*, 1905.
525. **Baudry de Saunier, L., and A. Gatoux.** Les Motocyclettes. *Svo. Paris*, 1904.
- Bauer, G.**, see **Agricola, G.**
526. **Bauer, H.** Zur Bestimmung des Schmelzpunktes der Asphalte. *Chem. Rev. Fett-Harz-Ind.*, bd. xii, pp. 258-260. [1905.]
527. **Bauer, J.** [Natural Gas, Feherkörös Valley, Hungary.] *Organ. Ver. Bohrtechn.*, bd. xiii, pp. 97-99. [1906.]
528. **Bauerman, H.** Note on a Geological Reconnaissance made in Arabia Petraea in the Spring of 1868. *Quart. Journ. Geol. Soc.*, vol. xxv, pp. 17-33, pl. i. [1869.]



529. **Bauhjn, J. H.** *Historia Novi et Admirabilis Fontis Balneique Bollenensis*. 4to, *Monthebhard*, 1598.
530. **Baum, E.** *Studin din punctul de vedere istoric, economic si scientific asupra dezvoltarii industriei petroliferi in Romania*. 8vo, *Bucharest*, 1896.
531. ——— *Le Petrole en liaison intime avec le sel gemme en Roumanie*. *Monit. Int. Petrol. Roum.*, t. ii, pp. 364-366. [1901.]
532. ——— [Oil Production in Campina. A Contribution to the History of the Rumanian Petroleum Industry.] *Ibid.*, t. viii, nos. 11, 12. [1907.]
533. **Baumhauer, E. H. v.** *Oyer de Aardolien der Nederlandsch-Oost-indische Bezittingen*. *Versl. Mededeel. Kon. Akad. Wetensch., Afd.-Nat.*, ser. 2, dl. iii, 'pp. 340-383. [1869.]
- Baylis, J. J.**, see **Wilkinson, C. S.**
534. **Beal, S.** *Travels of Pah-Hian and Sung-Yun, Buddhist Pilgrims from China to India*. 8vo, *London*, 1869.
535. **Beaufort, F.** *Karamania, or a Brief Description of the South Coast of Asia Minor, and of the Remains of Antiquity*. 8vo, *London*, 1817.
536. ——— *Memoir of a Survey of the Coast of Karamania, made in 1811 and 1812*. 8vo, *London*, 1820.
537. **Beaumont, E. de.** *Instructions pour la Géologie (pour une Exploration Scientifique de l'Algérie)*. *Compt. Rend.*, t. vii, pp. 142-182. [1838.]
538. **Beaumont, W. W.** *Motor Cars*. *Proc. Cleveland Inst. Eng.*, scss. 1896-1897, pp. 220-278. [1896.]
539. ——— *Motor Vehicles for Roads*. *Trans. Manchester Assoc. Eng.*, 1897, pp. 93-129.
540. ——— *Motor Vehicles and Motors: their design, construction, and working by steam, oil, and electricity*. 2 vols. 8vo, *London*, 1900, 1906.
541. ——— *Oil Engines for Agricultural Purposes*. *Journ. Board Agric.*, vol. x, pp. 435-460. [1904.]
542. ——— *Public Service Motor Transport*. *Proc. Inst. Automob. Eng.*, vol. vii, pp. 37. [1906.]
543. ——— *Petrol Motor Omnibuses*. *Proc. Inst. Mech. Eng.*, 1907, pp. 393-492, pls. xxiv-xxxiii.
544. **Bechhold, —**. *Untersuchungen an dem Klirbecken-schlamm [aus Abwasser] zu Frankfur-a-M.* *Zeitsch. angew. Chem.*, bd. xii, pp. 849-854. [1899.]
545. **Bechstein, L.** *Le pétrole employé dans le travail autour des métaux et alliages tres durs*. *Technol.*, t. xxx, p. 3901. [1868.]
546. **Bechstein, O.** *Einiges über das Beleuchtungswesen*. *Prometheus*, bd. xvii, pp. 744-747. [1906.]
547. ——— *Flüssiges Leuchtgas*. *Ibid.*, bd. xx, pp. 545-550. [1909.]
548. **Beck, L. C.** *Report on the Mineralogical and Chemical Department of the [Geological] Survey [of New York]*. *Assembly*, no. 200, pp. 7-73. [1838.]
549. ——— *Notices of the Native Copper, Ores of Copper and other Minerals found in the vicinity of New Brunswick, N.J.* *Amer. Journ.* (ser. 1), vol. xxxvi, pp. 107-114. [1839.]
550. ——— *Mineralogy of New York*. 4to, *Albany*, 1842.
551. ——— *On the Occurrence of Bituminous or Organic matter in several of the New York limestones and sandstones*. *Amer. Journ.* [ser. 1], vol. xiv, pp. 335, 336. [1843.]
552. **Becker, —**. *Ueber amerikanisches und russisches Petroleum*. *Zeitschr. angew. Chem.*, bd. vii, pp. 216-221. [1894.]
553. **Becker, G. F.** *The Geology of the Quicksilver Deposits of the Pacific Slope*. *U.S. Geol. Surv. Monogr.* no. xiii. 4to, *Washington*, 1888.
554. ——— *Memorandum on the Mineral Resources of the Philippine Islands*. *Ann. Rep. U.S. Geol. Surv.*, vol. xix, pt. vi, no. 2, pp. 687-693. [1898.]
555. ——— *Brief Memorandum on the Geology of the Philippine Islands*. *Ann. Rep. U.S. Geol. Surv.*, vol. xx, pt. 2, pp. 1-7. [1900.]
556. ——— *Report on the Geology of the Philippine Islands; followed by a Version of "Ueber tertiäre Fossilien von Philippinen" (1895), by K. Martin*. *Ibid.*, vol. xxi, pt. iii, pp. 487-625, pls. lxxvi-lxxviii (Charts). 1901.
557. **Becker, G. P.** *Relations between Local Magnetic Disturbances and the Genesis of Petroleum*. *Bull. U.S. Geol. Surv.*, no. 401. Pp. 24, [1910.]
558. **Becks, F.** *Vorläufige Notiz über ein neues Vorkommen von Asphalt in Westphalen*. *Ann. Phys. Chem.*, bd. cxxiii, pp. 297-400. [1839.]
559. **Beckwith, A.** *Report on Asphalt and Bitumen, as applied to the construction of streets and side-walks in Paris; also to terraces, roofs, etc., and to various products in the Exhibition of 1867, with observations upon macadamised streets and roads*. *Washington*, 1868.
560. **Beco, J.** *Note sur l'éclairage par incandescence au pétrole*. *Système Washington*. *Rev. Univ. Mines*, sér. 3, t. liv, pp. 106-108. [1901.]
561. **Beco, J., and L. Thouard.** *L'Industrie miniere en Italie depuis 1860 jusqu'en 1880*. *Ibid.*, sér. 2, t. xi, pp. 160-173, 426-461; t. xii, pp. 114-142; t. xiii, pp. 27-56, 311-361; t. xiv, pp. 89-116, 387-453, 652-693. [1882, 1883.]
562. **Bedford, J. E.** *Natural Gas and the Oil-Fields of America and Russia*. *Trans. Leeds Geol. Assoc.* [vol. i], pp. 187-194. [1859.]
563. **Bedson, P. P.** *Results of the Analysis of Samples of New Zealand Coal and Ambrite, and of Barbados Manjak*. *Trans. Inst. Min. Eng.*, vol. xvi, pp. 388-390. [1899.]
564. ——— *Paraffin Wax from the Ladysmith Pit, Whitehaven Collieries*. *Journ. Soc. Chem. Ind.*, vol. xxxi, pp. 1224, 1225. [1907.]
- Beede, J. W.**, see **Haworth, E.**
565. **Beeler, H. C.** *Wyoming Mines and Minerals*. 1904.
566. ——— *Mineral Resources of Wyoming*. 1907.
567. **Behrend, —**. *Spiritus contra Petroleum*. *Petroleum Zeitschr.*, bd. ii, p. 508. [1906.]
568. **Beilby, G. T.** *The Manufacture of Paraffin Oils*. *Trans. Insurance Soc. Glasg.*, 1883, pp. 123-142, 5 pls.
569. ——— *On the Specific Gravity of Paraffin, Solid, Fused, and in Solution*. *Journ. Chem. Soc.*, vol. xliii, pp. 388-390. [1883.]
570. ——— *The Production of Ammonia from the Nitrogen of Minerals*. *Journ. Soc. Arts*, vol. xxxiii, pp. 313-320. [1885.]
571. ——— *A New Method of Cooling Oils for the Extraction of Paraffin*. *Journ. Soc. Chem. Ind.*, vol. iv, pp. 321-325, 653-655. [1885.]
572. ——— *The Nitrogen of Crude Petroleum and Paraffin Oils*. *Ibid.*, vol. x, pp. 120, 121. [1891.]
573. ——— *Thirty Years of Progress in the Shale Oil Industry*. *Ibid.*, vol. xvi, pp. 876-886. [1897.]
574. **Beilstein, F. F.** [On the Determination of the Value of Kerosene.] *Zap. Imp. Russk. Tekhn. Obsch.*, g. xii, otd. 1, pp. 230-238. [1878.]
575. ——— *Ueber Petroleumprüfung*. *Zeitschr. anal. Chem.*, bd. xxii, pp. 309-316. [1883.]
576. ——— *Ueber die Prüfung des Petroleum durch Destillation*. *Chem. Ind.*, bd. vii, pp. 386, 387. [1884.]
577. **Beilstein, F. F., and A. Kurbatow.** *Ueber die Natur des kaukasischen Petroleums*. *Ber. deutsch. chem. Ges.*, bd. xiii, pp. 1818-1821; bd. xiv, pp. 1620-1622. [1880, 1881.]
578. ——— *Ueber die Kohlenwasserstoffe des amerikanischen Petroleums*. *Ibid.*, bd. xiii, pp. 2028, 2029. [1880.]
579. **Beilstein, F. F., B. Velejinski, and L. Jawein.** [Technical Regulations for the Supply of Mineral Lubricants to Machines and Railway Locomotives.] *Zap. Imp. Russk. Tekhn. Obsch.*, g. xvii, otd. 1, pp. 426-428. [1883.]
580. **Beilstein, F. F., and E. Wiegand.** *Ueber kaukasischen Ozokerit [Tcheleken I.]*. *Ber. deutsch. chem. Ges.*, bd. xvi, pp. 1547-1551. [1883.]
581. **Beketov, N.** [Experiments, confirming Mendeleev's Hypothesis of the Origin of Petroleum.] *Journ. Russk. Phiz. Khim. Obsch.*, t. xxviii, otd. ii, p. 893. [1896.]
582. **Bell, A. M.** *Petroleum Oil Fuel*. 8vo, *London*, 1902.

583. **Bell, C., D. R. Steuart, and A. E. Powell.** Discussion on the Flashing Point of Mineral Oils. *Journ. Soc. Chem. Ind.*, vol. xii, pp. 991-994. [1893.]
584. **Bell, J.** Travels from St. Petersburg in Russia to Diverse Parts of Asia. 4to, Glasgow, 1790.
585. **Bell, J. C.** Estimation of Water in Paraffin Residues and Crude Paraffin. *Chem. News*, vol. xxx, pp. 57, 58. [1874.]
586. **Bell, J. M.** The Salient Features of the Economic Geology of New Zealand. *Econ. Geol.*, vol. 1, pp. 735-750. [1906.]
587. ——— Petroleum in New Zealand. *Trans. Austral. Inst. Mining Eng.*, vol. xlii, p. 84. [1910.]
588. **Bell, R.** Grand Manitoulin Island. *Rep. Geol. Surv. Canada*, 1863-1866, pp. 165-179. [1866.]
589. ——— Report on an Exploration of the East Coast of Hudson's Bay, 1877. *Ibid.*, 1877-78, C, pp. 37 [1879.]
590. ——— On the Occurrence of Petroleum in the North-West Territories; with Notes on New Localities. *Proc. Canad. Inst.*, n.s., vol. 1, pp. 225-230. [1881.]
591. ——— Report on Part of the Basin of the Athabasca River, North-West Territory. *Rep. Geol. Surv. Canada*, 1882-84, CC, pp. 37, map. 1885.
592. ——— The Geology and Economic Minerals of Hudson's Bay and Northern Canada. *Trans. Roy. Soc. Canada*, ser. 1, vol. ii, sect. 4, pp. 241-245. [1886.]
593. ——— The Mineral Resources of the Hudson's Bay Territories. *Trans. Amer. Inst. Min. Eng.*, vol. xiv, pp. 690-698. [1886.]
594. ——— The Petroleum Field of Ontario. *Trans. R. Soc. Canada*, vol. v, sec. 4, pp. 101-113. [1887.]
595. ——— Report on the Geology of the French River Sheet 125, Ontario. *Ann. Rep. Geol. Surv. Canada* 1896, 1, pp. 29, map. [1897.]
596. ——— Summary Report[s] of the Geological Survey Department of Canada for the Calendar Year[s] 1901-1905. 8vo, Ottawa, 1902-1906.]
597. ——— The "Tar-Sands" of the Athabasca River (Canada). *Trans. Amer. Inst. Min. Eng.*, vol. xxxviii, pp. 836-848. [1908.]
598. **Belleruche, E.** De l'emploi des Hydrocarbures comme Lubrifiants dans le Matériel des Chemins de Fer et le Graissage des Machines. *Rev. Univ. Mines*, sér. 2, t. xiii, pp. 243-310. [1883.]
599. **Bellford, A. E. L.** Mode de fabrication de certaines huiles minérales et de la paraffine. *Technol.*, t. xvi, pp. 464, 465. [1855.]
600. **Bender, —.** Ueber die Löslichkeit der Mineralöle in Benzin. *Mith. k. techn. Versuchsanst.*, bd. viii, pp. 311-316. [1890.]
601. **Bender, C.** Zur Prüfung des Brikettpeches. *Zeitschr. angew. Chem.*, bd. xviii, p. 954. [1905.]
602. **Benecke, E. W.** Abriss der Geologie von Elsass-Lothringen. 8vo, Strassburg, 1878.
603. **Benedict, A. C.** Petroleum in Indiana. 17th Ann. *Rep. Geol. Indiana*, pp. 306-325. [1892.]
- Benedict, A. C.** see **Eirolod, M. N.**
604. **Benedikt, R.** Analyse der Fette und Wachstern. Berlin, 1886.
605. **Beneke, A.** Die Theorie der durch Gasexplosionen verursachten Druckwirkungen, wie sie in Motoren zur Geltung kommen. *Gasmotorentechnik*, bd. xi, pp. 73-75. [1911.]
606. **Benger, G.** România in 1900. Bucharest, 1900.
607. **Benjamin, M.** Mineral Wax, a Résumé. [1881.]
608. **Benkenдорff, A.** Ueber Wasserverhältnisse und wasserführende Schichten des apscheronen Oelgebietes. *Compt. Rend. Congr. internat. Pétrole*, sess. 3, t. ii, pp. 199-202. [1910.]
609. **Benko, G.** and **K. Jahn.** [Analysis of Asphalt from Zsil-Vajdei, Transylvania.] *Orv.-term. Tud. Ert.*, 1886, p. 159.
610. **Benndorf, O.**, and **G. Niemann.** Reisen in Südwestlichen Kleinasien. Vienna, 1884.
611. **Bennett, —.** Reports for the years 1902, 1905, 1906 on the Trade, etc., of the States of California, Nevada, Utah, and Arizona. *Dipl. Cons. Rep.*, ann. ser., nos. 2988, 3564, and 3782. [1903-1907.]
612. **Bennett, A. P.** Report on the Petroleum Industry in Roumania. *Dipl. Cons. Rep.*, misc. ser., no. 411. [1896.]
- Bennett, J.**, see **Haworth, E.**
613. **Bennett, J. H.** An Investigation into the Structure of the Torbanhill Mineral and of various kinds of Coal. *Quart. Journ. Mier. Soc.*, vol. iii, pp. 185-193. [1855.]
614. **Benoit, E.** Note sur les terrains entre le Jura et les Alpes. *Bull. Soc. Géol. France*, sér. 2, t. xvii, pp. 387-413. [1860.]
615. **Benoit, E., Giron, and A. Gniselin.** Définition des Produits Chimériques. *Compt. Rend. Congr. internat. Congr. Pétrole*, sess. 3, t. ii, pp. 808, 809. [1910.]
616. **Bensmann, H.** Le Floridin, son Emploi dans le Raffinage des Produits de Pétrole. *Ibid.*, pp. 695-704. [1910.]
617. **Berendt, G.** [Reported Petroleum near Mewe, West Prussia.] *Schrift. phys.-ökon. Ges. Königsberg*, bii, ix, Sitz., p. 19. [1868.]
618. **Berezin, L.** [Journey through Dagestan and Transcaucasia.] 8vo, Kazan, 1850.
619. **Berozin, N.** [Remarks on the Apsheron Peninsula.] *Otechest. Zap.*, 1846, no. 12.
620. ——— [Travels in the Apsheron Peninsula.] *Zakark. Viestn.*, 1847, no. 21.
621. **Berg, A.** Ueber den Chimaera. *Zeitschr. allg. Erdk.*, bd. iii, pp. 307-314. [1854.]
622. **Berg, J.** The Production of Lubricating Oils by Concentration. 1st *Internat. Petrol. Congr.*, pp. 75, 76. [1900.]
623. ——— Die technisch-wirtschaftlichen Verhältnisse in der Schmierölfabrikation zu Baku. *Chem. Rev. Fett-Harz-Ind.*, bd. viii, pp. 119-121, 139-141. [1901.]
624. ——— Ueber zweckmässige Feuerungsanlagen bei der Destillation von Mineralölen. *Ibid.*, pp. 184, 185. [1901.]
625. ——— The Dephlegmator in Mineral Oil Refineries. *Petr. Rev.*, vol. iv, p. 553. [1901.]
626. ——— The Manufacture of Lubricating Oils in the Refinery of the Schibaleff Company. *Petroleum*, vol. ii, pp. 686, 687. [1902.]
627. **Bjergé, H.** Fabrication du gaz au moyen du pétrole. *Le Chimiste*, ann. 3, pp. 305-316. [1868.]
628. **Borger, L.** The Physical Properties of Gasoline and Kerosene. *Horpeless Age*, vol. ix, pp. 630-632. [1902.]
629. **Berghaus, H.** Asia. Geo-hydrographisches Memoir . . . 2 Bde. 4to, Götta, 1832, 1835.
- Bergmann, A.**, see **Göbel, F.**
630. **Bergmann, T.** Producta Ignis Subterranei chemice considerata. *N. Act. R. Soc. Sci. Upsala*, t. iii, 1777.
631. ——— Opuscula physica et chemica. Tt. v. 8vo, Stockholm, etc., 1779-1788.
632. ——— Scigraphia Regni Mineralis. 16mo, Leipzig and Dessau, 1782.
633. **Berguer, L.** Zur Frage der Untersuchung der Handels-Petroleums. Ueber die sogenannte Natronprobe. *Compt. Rend. Congr. internat. Chim. Appl.*, sess. 5, t. i, pp. 501-504. [1904.]
634. **Berkeley, E.** Observations and Remarks on the Eruptions of Fire and Smoke from Mount Vesuvius. *Phil. Trans.*, vol. xxx, p. 708. [1717.]
635. **Berlinerblau, J.** Das Erdwachs, Ozokerit und Ceresin. Geschichte, Vorkommen, Gewinnung und Verarbeitung. 8vo, Brunswick, 1897.
636. ——— Refraktometrische Bestimmungen von Paraffin. *Compt. Rend. Congr. internat. Chim. Appl.*, sess. 5, t. ii, pp. 619-624. [1904.]
637. **Berlinerblau, J.**, and **E. Reichardt.** [Colouring Matter of the Galician Ozokerite.] *Berne*, 1888.
638. **Berndt, O.** Die Erdölmotoren auf der internationalen Ausstellung für Bäckerei, Konditorei und verwandte Gewerbe zu Mainz im August 1893. *Zeitschr. Ver. deutsch. Ing.*, bd. xxxviii, pp. 195-198, 215-219. [1894.]

639. **Bernouilli, J.** Lettres sur différens Sujets, écrites pendant le cours d'un Voyage par l'Allemagne, la Suisse, la France méridionale, et l'Italie, en 1774 et 1775. 3 Tt. 8vo, Berlin, 1777-1779.
640. **Bernstein, A.** Prüfung der Entzündlichkeit des Petroleum. *Sitz. Ver. Bepfrd. Gewerbk.*, 1879, pp. 173-184.
641. — Petroleum-Prüfungsapparat. *Deutsch. Ind. Zeit.*, 1879, p. 517, pl. x.
- Bernstein, A.** see **Pöhlitz, A. L.**
642. **Beroldingen, F. v.** Beobachtungen, Zweifel und Fragen die Mineralogie betreffend. 8vo, Hanover, 1778, 1793.
643. **Berry, D. M.** Petroleum and Asphaltum of Southern California. In "California of the South" . . . by W. Lindley and J. P. Widney. 8vo, New York, 1888.
644. **Bertels, G. A.** Ueber den Naphta-district des nordwestlichen Kaukasus. *Korr.-Bl. nat. Ver. Riga*, bd. xxi, no. 11 [1875].
645. — Erdöl, Schlammvulkane und Steinkohle. Betrachtungen und Beobachtungen über deren Ursprung und Entstehen. 8vo, Riga, 1892.
646. **Bertenson, L.** [Medico-sanitary Aspect of the Baku Petroleum Industry.] *Gorn. Journ.*, 1897, t. 3, pp. 216-230.
647. **Berthelot, M. P. E.** Synthèse des carbures d'hydrogène. *Compt. Rend.*, t. xliii, pp. 236-238. [1866.]
648. — Sur l'analyse des gaz carbures. *Ann. Chim. Phys.*, sér. 3, t. II, pp. 59-81. [1857.]
649. — Nouvelles recherches sur la formation des carbures d'hydrogène. *Compt. Rend.*, t. liv, pp. 515-519. [1862.]
650. — On the Synthesis of Organic Substances. *Journ. Chem. Soc.*, vol. xvii, pp. 37-49. [1864.]
651. — Action de l'étincelle électrique sur les mélanges d'hydrogène et de gaz carbonés. *Ann. Chim. Phys.*, sér. 4, t. ix, pp. 418-421. [1866.]
652. — Action de l'hydrogène libre sur les carbures d'hydrogène. *Ibid.*, pp. 431-445. [1866.]
653. — Théorie des corps pyrogénés. *Ibid.*, pp. 469-480. [1866.]
654. — Action de la chaleur sur quelques carbures d'hydrogène. *Compt. Rend.*, t. lxii, pp. 905-909, 947-949. [1866.]
655. — Sur l'Origine des Carbures et des Combustibles Minéraux. *Ibid.*, pp. 949-951. [1866.]
656. — Sur les caractères de la benzine et du styrolène, comparés avec ceux des autres carbures d'hydrogène. *Bull. Soc. Chim. Paris*, sér. 2, t. vi, pp. 289-296, [1866.]
657. — Action de la chaleur sur la benzine et sur les carbures analogues. *Compt. Rend.*, t. lxiii, pp. 788-793, 834-836. [1866.]
658. — Action du potassium sur les carbures d'hydrogène. *Ibid.*, pp. 836-838. [1866.]
659. — Sur les actions réciproques des carbures d'hydrogène. *Ibid.*, pp. 998-1003, 1077-1081. [1866.]
660. — Nouveau caractère pour l'analyse qualitative des gaz hydrocarbonés. *Bull. Soc. Chim. Paris*, sér. 2, t. v, pp. 95-97. [1866.]
661. — Action de la chaleur sur l'hydrure d'éthylène et sur l'éthylène mélangé d'hydrogène. *Ibid.*, pp. 405-413. [1866.]
662. — Sur les caractères de la benzine et du styrolène, comparés avec ceux des autres carbures d'hydrogène. *Ibid.*, t. vi, pp. 289-296. [1866.]
663. — Sur les combinaisons de l'acide picrique avec les carbures d'hydrogène, et sur leur emploi dans l'analyse. *Ibid.*, t. vii, pp. 30-43 [1867.]
664. — Sur les propriétés oxydantes des homologues de la benzine. *Ibid.*, pp. 109, 110. [1867.]
665. — Sur quelques conditions thermo-chimiques qui déterminent les réactions pyrogénées. *Ibid.*, pp. 122-124. [1867.]
666. — Action de la chaleur sur les homologues de la benzine. *Ibid.*, pp. 217-230. [1867.]
667. **Berthelot, M. P. E.** Sur la théorie des corps polymères et sur la série aromatique. *Bull. Soc. Chim. Paris*, sér. 2, t. vii, pp. 310-321. [1867.]
668. — Sur la formation simultanée des corps homologues dans les réactions pyrogénées. *Ibid.*, t. viii, pp. 306-313. [1867.]
669. — Méthode universelle pour réduire et saturer d'hydrogène les composés organiques. *Compt. Rend.*, t. lxiv, pp. 710-715, 760-764, 786-791, 829-832. [1867.]
670. — Sur les carbures pyrogénés. *Ibid.*, t. lxvi, pp. 624-627. [1868.]
671. — Sur la transformation directe du gaz des marais en carbures plus condensés. *Ibid.*, t. lxvii, pp. 233-237. [1868.]
672. — Formation des homologues de la benzine par l'action réciproque des carbures plus simples pris à l'état de liberté. *Ibid.*, pp. 846-849. [1868.]
673. — Sur la matière carbonneuse des météorites. *Ibid.*, p. 849. [1868.]
674. — Action de l'étincelle électrique sur les gaz des marais. *Ibid.*, pp. 1188-1192. [1868.]
675. — Sur l'oxydation des carbures d'hydrogène. *Ibid.*, t. lxviii, pp. 334, 335. [1869.]
676. — Sur la théorie des carbures d'hydrogène. *Bull. Soc. Chim. Paris*, sér. 2, t. xi, pp. 355-372. [1869.]
677. — Carbures pyrogénés. Sur la formation des carbures pyrogénés. *Ann. Chim. Phys.*, sér. 4, t. xvi, pp. 143-187. [1869.]
678. — Recherches sur les états du carbone. *Ibid.*, t. xix, pp. 392-427. [1870.]
679. — Nouvelles recherches sur les carbures pyrogénés, et sur la composition du gaz de l'éclairage. *Compt. Rend.*, t. lxxxii, pp. 871-875, 927-932. [1876.]
680. — Sur l'analyse des gaz pyrogénés. *Ibid.*, t. lxxxiii, pp. 1255-1259. [1876.]
681. — Remarques sur la présence de la benzine dans le gaz de l'éclairage. *Ibid.*, t. lxxxiv, pp. 571-576. [1877.]
682. — Sur l'hydrogénation de la benzine et des composés aromatiques. *Ibid.*, t. lxxxv, pp. 831-836. [1877.]
683. — Sur l'oxydation et l'éthylène. *Bull. Soc. Chim. Paris*, sér. 2, t. xxix, pp. 339-341. [1878.]
684. — Sur la chaleur de combustion des principaux gaz hydrocarbonés. *Compt. Rend.*, t. xc, pp. 1240-1246. [1880.]
685. — Les Carbures d'Hydrogène 1851-1901. Recherches expérimentales. 3 Tt. 8vo, Paris, 1901.
686. **Berthelot, M. P. E.**, and — **Matignon.** Sur la chaleur de combustion des principaux gaz hydrocarbonés. *Compt. Rend.*, t. cxvi, pp. 1333-1339. [1893.]
687. **Berthelot, M. P. E.**, and — **Recoura.** Bombe calorimétrique. *Ibid.*, t. civ, pp. 875-880. [1887.]
688. **Berthelot, M. P. E.**, and — **Vieille.** Sur les chaleurs de combustion des carbures d'hydrogène solides. *Ibid.*, t. cii, pp. 1211-1217. [1886.]
689. **Berthier, P.** Analyse de quelques minerais de bitume [de France]. *Ann. Mines*, sér. 3, t. xiii, pp. 605-616. [1838.]
690. — Analyse du calcaire bitumineux du Val de Travers, principauté de Neuchâtel. *Ibid.*, sér. 3, t. xv, pp. 564, 565. [1839.]
691. — Analyse des schistes bitumineux d'Aulun. *Ibid.*, pp. 616-618. [1839.]
692. **Bertin, E.** Chaudières marines. 8vo, Paris, 1896.
693. **Bertoljo, A.** Di un Grasso fossile di Rio Janeiro. *Atti Soc. Ital. Sci. Nat.*, vol. ii, pp. 140, 141. [1859.]
694. **Bertolio, S.** Distretto di Milano. *Riv. Serv. Min.*, 1896, pp. 191-232. [1897.]
695. — Sulla genesi del giacimenti di petrolio. *Ann. Soc. Chim. Milan*, 1898.
696. — Sulla ricerca dei giacimenti di petrolio. *Rass. Min.*, vol. x, 1899.

697. **Berton, Jules de.** Depression de la vallée du Jourdain et du lac Asphaltite. *Bull. Soc. Geogr. Paris*, sér. 2, t. xii, pp. 113-166. [1860.]
698. **Bertrand, C. E.** Le Boghead d'Autun. *Bull. Soc. Industr. Min.*, sér. 3, t. vi, pp. 453-506, pls. xiii, a, b. [1892.]
699. ——— Nouvelles remarques sur le Kerosene Shale de la Nouvelle-Galles du Sud. *Bull. Soc. Hist. Nat. Autun*, t. xii, pp. 193-292. [1896.]
700. ——— Caractéristiques du Charbon humique de Broxburn, près Bathgate (Écosse). *Ann. Soc. géol. Nord*, t. xxiv, pp. 129-134. [1897.]
701. ——— Caractéristiques du Kerosene Shale dans les gisements du Northern Coalfield et de Newcastle, Nouvelle-Galles du Sud. *Compt. Rend. Assoc. Franç.*, sess. 26, 1897, pt. 2, pp. 341-346. [1898.]
702. ——— Caractéristiques du Schiste bitumineux du Bois d'Asson (Basses Alpes). *Compt. Rend.*, t. ccxvi, pp. 1677-1679. [1898.]
703. ——— Premières conclusions générales sur les charbons humiques. *Ibid.*, t. ccxvii, pp. 767-769. [1898.]
704. ——— Les Charbons Humiques et les Charbons de Purins. *Compt. Rend. Assoc. Franç.*, sess. xxvi, pt. 2, pp. 328-340. [1898.]
705. ——— Description d'un Echantillon de Kerosene Shale de Megalong Valley, près Katomba (Nouvelles-Galles du Sud). *Ann. Soc. géol. Nord*, t. xxix, pp. 25-36. [1900.]
706. ——— Charbons gélosiques et charbons humiques. *Compt. Rend. VIII. Congrès géol. internat.*, pp. 458-497. [1901.]
707. **Bertrand, C. E.**, and **B. Renault.** *Pila Bibractensis* et le Boghead d'Autun. *Bull. Soc. Hist. Nat. Autun*, t. v. [1892.]
708. ——— *Reinschia australis* et premières remarques sur le Kerosene Shale, de la Nouvelle-Galles du Sud. *Ibid.*, t. vi, viii. [1893, 1895.]
709. ——— Sur le *Reinschia australis*, algue permo-carbonifère qui a formé le Kerosene Shale d'Australie. *Compt. Rend. Assoc. Franç.*, 1893, pt. ii, pp. 490-502. [1894.]
- Bertrand, C. E.**, see **Renault, B.**
710. **Bertrand, E.** Dictionnaire universel des fossiles propres et des fossiles accidentels. *La Haye*, 1763.
711. **Besson, A. G.** [On Petroleum Fuel for Boilers.] *Gorn. Journ.*, 1886, t. 4, pp. 364-372; 1887, t. 1, pp. 33-46.
- Best, A.**, see **Coates, C. E.**
712. **Best, W. N.** The Science of Burning Liquid Fuel. *Eng. Min Journ.*, vol. lxxvii, pp. 771, 772. [1904.]
713. ——— [Oil-Fired Furnaces.] *Trans. Amer. Foundrymen's Assoc.*, 1911, pp. 421-424.
714. **Bendant, F. S.** Traité Élémentaire de Mineralogie. 8vo, Paris, 1827.
715. **Beyer, S. W.** Geology of Story County. *Ann. Rep. Iowa Geol. Surv.*, vol. ix, pp. 155-237, pls. iii, iv, and 2 maps, 1:125,000. [1899.]
716. **Beyschlag, F.** Die Verwässerung des Oelgebietes von Tustanowice. *Petroleum Zeitschr.*, bd. vii, pp. 105, 106. [1911.]
- Beyschlag, F.**, see **Monke, A.**
717. **Bialobjeski, Tch.** L'Ionisation des Hydrocarbures Liquides. *Le Radium*, t. viii, pp. 293-299. [1911.]
718. **Bianconi, F.**, and **J. Doumerc.** Algérie 1<sup>o</sup>: Province d'Oran. Cartes Commerciales . . . avec Notice Descriptive. . . Ser. 4, no. 5. 4to, Paris, 1890.
719. **Bianconi, G. G.** Dei fenomeni geologici operati dal gas idrogeno, e della origine di esso gas. *Nuovi Ann. Sci. Nat.*, vol. ii, pp. 422-435. [1838.]
720. ——— Sul fenomeni geologici operati dal gas idrogeno. *Ibid.*, vol. lii, pp. 60-72, 115-128, 200-214, 241-256, 348-371, 421-439; vol. iv, 110-126, 165-180, 278-302, 349-389. [1840.]
721. ——— Storia naturale dei terreni ardenti, dei vulcani fangosi, delle sorgenti infiammabili, dei pozzi idropirici, e di altri fenomeni geologici operati dal gas idrogeno, e della origine di esso gas. 8vo, Bologna, 1840.
722. **Bickerton, H. N.** Gas, Oil and Petrol Engines. *Gas and Oil Eng. Rev.*, vol. ii, pp. 250, 251, 274, 275. [1906.]
723. **Bickford, J. S. V.** Petroleum Vapor Burners—General Principles. *Horseless Age*, vol. ix, pp. 632-635. [1902.]
724. **Bideky, L.** Der Asphalt, seine Gewinnung, Bereitung und Verwendung in der Technik. *Polyt. Journ.*, bd. ccvii, pp. 240-253, 328-337. [1872.]
725. **Bidou, L.** Gisements des bitumes, pétroles et de divers minéraux dans les provinces de Chieti et de Frosinone, et traitement des matières bitumineuses à Letto Manoppello, 4to, Siena, 1877.
726. **Biel, J.** Vergleichende Untersuchungen amerikanischer und russischer Petroleumsorten. *Pharm. Zeitschr. Russl.*, bd. xvii, pp. 129-139; bd. xviii, pp. 162-169, 194-202. [1878, 1879.]
727. ——— Russisches Benzin. *Ibid.*, bd. xix, pp. 746, 747. [1880.]
728. ——— Ueber Russisches Vaseline. *Ibid.*, bd. xxi, pp. 41-43. [1882.]
729. ——— Untersuchungen Amerikanischer und Russischer Petroleumsorten. *Polyt. Journ.*, bd. ccxxii, pp. 354-363. [1879.]
730. ——— Zur Untersuchung von russischem Erdöle und Erdöllampen. *Ibid.*, bd. cciii, pp. 119-123. [1884.]
731. **Bielczyk, —.** [Influence of Petroleum on the Health of the Workers at the Wells in the Carpathians.] *Przeglad Lekarski*, 1886, no. 20.
732. **Bielefeldt, M.** Ueber die Derivate des Isodurols. *Ann. Chem. Pharm.*, bd. ccviii, pp. 380-388. [1879.]
733. **Bielhain, M.** [The North-American Oil Industry.] *Izv. Obsch. Gorn. Inžen.*, 1894, nos. 5-6, pp. 15-27.
734. **Bielski, Z.** Kurze Uebersicht der neueren Tiefbohrsysteme. *Naphtha*, bd. xiii, pp. 340-344, 366-368, 382-385, 410-412, 429-433, 452-458, 471-475. [1905.]
735. **Bielz, E. A.** Warum im innern Becken Siebenbürgens keine Erdöl-Quellen vorkommen? *Verh. Siebenb. Ver. Nat.*, bd. xvi, pp. 216-219. [1865.]
736. **Bielz, E. H.** Gasquellen Siebenbürgens. *Jahrb. Siebenb. Karp. Ver.*, 1882.
737. **Bielz, J. A.** Die in Siebenbürgen vorkommenden Mineralien und Gesteine. *Verh. Siebenb. Ver. Nat.*, bd. xxxix, pp. 1-82. [1889.]
738. **Bienamyé, A. F. H.** Les Machines Marines. 4to, Paris, 1877.
739. **Bigelow, H. J.** Rhigolene, a Petroleum Naphtha for Producing Anaesthetics by Freezing. *Chem. News*, vol. xiii, pp. 244, 245. [1866.]
740. **Bigge, H.** [Notice of the Discovery of Coal and Petroleum on the Namrup River.] *Journ. As. Soc. Beng.*, vol. vi, p. 243. [1837.]
741. **Bigsby, J.** On the Geology of Quebec and its Environs. *Quart. Journ. Geol. Soc.*, vol. ix, pp. 82-101, pl. vi. [1853.]
742. **Billot, J. T.** Coupes géologiques du Sud-Ouest. *Acad. Soc. Linn. Bordeaux*, sér. 6, t. iii, pp. 25-34. [1898.]
743. **Biltz, —.** Braunkohle und ihre Destillationsprodukte. *Bayer. Ind. Gewerb.*, bd. xxxii, pp. 267, 268. [1900.]
744. **Binney, E. W.** Observations on Down Holland Moss. *Trans. Manch. Geol. Soc.*, vol. iii, pp. 9-18. [1860.]
745. ——— [Petroleum in Lancashire and Derbyshire.] *Proc. Lit. Phil. Soc. Manch.*, vol. viii, pp. 135-137. [1869.]
746. ——— [On Bituminous Minerals from New South Wales.] *Trans. Manch. Geol. Soc.*, vol. x, pp. 63-70. [1871.]
747. ——— Observations on Coal. *Proc. Lit. Phil. Soc. Manch.*, vol. xiii, pp. 125-129. [1874.]
748. **Binney, E. W.**, and **H. J. Talbot.** On the Petroleum found in the Down Holland Moss near Ormskirk. *Trans. Manch. Geol. Soc.*, vol. viii, pp. 41-48. [1868.]
- Binney, E. W.**, see **Greenwell, G. C.**
749. **Binning, R. M. B.** A Journal of Two Years' Travel in Persia, Ceylon, etc. 2 vols. 8vo, London, 1857.

750. **Biot, J. B.** Memoire sur la Polarisation Circulaire et sur les Applications à la Chimie organique. *Mém. Ac. Sci. Paris*, ser. 2, t. xiii, pp. 39-175, 2 tables, pl. [1835.]
- Biguard, R.**, see **Moureu, C.**
751. **Bisard, —**, — **Labarre.** Réservoir destiné à emmagasiner les huiles de pétrole, et autres matières inflammables plus légères que l'eau. *Gén. Ind.*, t. xxxii, pp. 39-42, pl. 409. [1866.]
752. **Bischof, C. G. C.** Lehrbuch der chemischen und physikalischen Geologie. 2 Bde. 8vo, Bonn, 1847, 1854.
753. **Bischof, F.** Ueber den Brennwerth einiger Braunkohlen in der Provinz Sachsen. *Polyt. Journ.*, bd. cxvi, pp. 103-112. [1850.]
754. ———— Les Mines de Sel gemme de Stassfurt (Prusse). *Ann. Chim. Phys.*, sér. 4, t. v, pp. 295-349. [1865.]
755. **Bischoff, H.** Analyse d'un jayet provenant de la molasse, près d'Yverdon. *Bull. Soc. Vaud. Sci. Nat.*, t. iv, pp. 317, 318. [1855.]
756. **Bishop, I. P.** The Structural and Economic Geology of Erie County. *Ann. Rep. N. York State Mus.*, vol. xlix, pt. 2, pp. 305-392, pls. i-xvi. [1898.]
757. ———— Petroleum and Natural Gas in Western New York. *Ibid.*, vol. li, pt. 2, pp. 9-63, map. [1899.]
758. ———— Oil and Gas in Southwestern New York. *Ibid.*, vol. liii, pt. 1, R, pp. 105-134. [1901.]
759. ———— Economic Geology of Western New York. *Ibid.*, vol. lvi, pt. 1, pp. 42-74, pl. xxviii. [1904.]
760. **Bissinger, E.** Petroleum Fields of Egypt. *Rep. Cons. U.S.*, vol. xxi, pp. 423-426, 555, 556. [1887.]
761. ———— Petroleum Discovery in Syria. *Ibid.*, vol. xxxiii, pp. 210-212. [1890.]
762. **Bittner, A.** Ueber die geologischen Aufnahmen in Judicarien [Tirol] und Val Sabbia [Lombardia]. *Jahrb. k.-k. Reichs. bd. xxxi*, pp. 219-379, pls. iv-vi. [1881.]
763. ———— Nachrichten zum Berichte über die geologischen Aufnahmen in Judicarien und Val Sabbia. *Ibid.*, bd. xxxiii, pp. 405-442. [1883.]
764. **Bizio, G.** Sopra l'acidificazione del petrolio a contatto dell'aria. *Atti R. Inst. Ven. Sci.*, vol. i, pp. 200-220. [1856.]
765. ———— Analisi des gas uscente dai pozzi artesiani di Venezia. *Ibid.*, vol. vi, pp. 448-451. [1861.]
766. ———— Vorträge über [afrikanischen] Petroleum. *Venet. Handelsinstitut*, 1874.
- Bizio, G.**, see **Kauer, A.**
767. **Björklund, G. A.** Reiseskizzen aus Transkaukasien. *Pharm. Zeitschr. Russl.*, bd. vii, pp. 149-155. [1368.]
768. ———— Mittheilungen über das Vorkommen der Naphtha und des Ozokerit in Asien und in Europa. *Ibid.*, bd. ix, pp. 46-51. [1870.]
769. **Björling, P. R.** Briquettes and Patent Fuel; their Manufacture, etc. 8vo, London, 1903.
770. **Blaauw, W. H.** Die Organisation der galizischen Petroleumindustrie und die heutige Krisis. *Naphtha*, jg. xv, pp. 385-390, 405-408, 427-431. [1907.]
771. **Blachette, L. J.** Dei gaz infiammabili. *Giorn. Farm.*, vol. li, pp. 169-174. [1825.]
772. **Black, J.** Lectures on the Elements of Chemistry delivered in the University of Edinburgh. 2 vols. 4to, Edinburgh, 1803.
773. **Blackmar, C. A.** Register of Oil Wells, Los Angeles County. *Reg. Calif. State Min. Bureau*, 1903, 1904.
774. **Blake, E. C.** The Use of Natural Gas in a Lead Blast Furnace. *Trans. Amer. Inst. Min. Eng.*, vol. xv, pp. 661, 662. [1887.]
775. **Blake, G. S.** The Asphalt Industry of Trinidad (W.I.). *Bull. Imp. Inst.*, vol. i, pp. li-iv. [1903.]
776. ———— Oil Shale from Natal, analysis. *Ibid.*, pp. 74-76. [1903.]
777. **Blake, J. H.** Coal Mines in Cuba. *Amer. Journ.*, ser. i, vol. xlii, pp. 388-390. [1842.]
778. **Blake, W. P.** Explorations and Surveys for a Railroad Route from the Mississippi River to the Pacific Ocean. Vol. V.: Route in California. Pt. 2, Geology of portions of the Route, pp. 131-310, 8 pls. 4to, Washington, 1855.
779. **Blake, W. P.** Observations on the Physical Geography and Geology of the Coast of California from Bodega Bay to San Diego. 4to, Washington, 1855.
780. ———— New Mineral Oil Regions in the Tulare Valley. *Proc. Calif. Ac. Sci.*, vol. iii, p. 193. [1865.]
781. ———— On the Mineral Resources of Yesso. In H. Capron's "Report to the Kaitakushi" (8vo, Tokio, 1875), p. 1-16.
782. ———— Uintaite, a new variety of asphaltum from the Uintah Mountains, Utah. *Eng. Min. Journ.*, vol. xl, p. 431. [1885.]
783. ———— Uintaite, Albertite, Grahamite and Asphaltum described and compared with observations on Bitumen and its compounds. *Trans. Amer. Inst. Min. Eng.*, vol. xviii, pp. 563-582. [1890.]
784. ———— The Existence of Faults and Dislocations in the Lead and Zinc Regions of the Mississippi Valley, with observations on the genesis of the ores. *Ibid.*, vol. xxii, pp. 621-634. [1894.]
785. **Blanc, E.** Note sur les Gisements de Pétrole de l'Asie centrale. *Bull. Mus. Hist. Nat. Paris*, t. xv, pp. 212-222. [1909.]
786. **Blanchet, R.**, and **E. Sell.** Die Zusammensetzung einiger organischer Substanzen. *Ann. Chem. Pharm.*, bd. vi, pp. 259-313. [1833.]
787. **Blanchenhorn, M.** Ueber das Vorkommen von Phosphaten, Asphaltkalk, Asphalt und Petroleum in Palästina und Aegypten. *Zeitschr. prakt. Geol.*, bd. xi, pp. 294-298. [1903.]
- Blanchenhorn, M.**, see **Oebbecke, K.**
788. **Blanco, A.** Mineral Resources and Industry of Bolivia. *Board of Trade Journ.*, vol. lxxiv, pp. 23, 24. [1911.]
- Blanford, W. T.**, see **Medlicott, H. B.**
789. **Blaschewski, —**. Naphtha-Ausbruch im Kaspischen Meere. *Ann. Hydogr.*, 1905, p. 39.
790. **Blass, G.** Beitrag zur Schmiermittelfrage. *Glückauf*, bd. xli, pp. 1199-1203. [1905.]
791. **Blass, J. C.** Geschichte, Industrie und chemische Zusammensetzung der amerikanischen Petroleumum. *Arch. Pharm.*, bd. cxcl, pp. 50-67. [1870.]
792. **Blatchley, R. F.** The Oakland City, Indiana, Oil Field in 1910. *Ann. Rep. Geol. Surv. Indiana*, vol. xxxv, pp. 79-143; 2 pls. [1911.]
793. **Blatchley, R. S.** The Mineral Production of Illinois in 1908. *Ill. Geol. Surv.*, Circ. 5. Pp. 20. [1909.]
794. ———— Drilling for Oil in Eastern Illinois. *Min. Sci. Press*, vol. xcix, pp. 613-617. [1909.]
795. ———— Petroleum in Illinois. *Eng. Min. Journ.*, vol. lxxxix, pp. 133, 134. [1910.]
796. ———— Petroleum Mining Engineering. *Mines and Minerals*, vol. xxxi, pp. 442, 443. [1911.]
797. ———— Oil Resources of Illinois, with Special Reference to the Area outside the Southeastern Fields. *Bull. Geol. Surv. Illinois*, no. 16. Pp. 138, pls. vi-xviii. [1910.]
798. ———— The Petroleum Resources of Illinois. *Petrol. Rev.*, vol. xxv, pp. 101, 102. [1911.]
799. ———— The Origin and Accumulation of Oil. *Ibid.*, vol. xxv, pp. 143, 144, 175, 176. [1911.]
800. ———— Randolph County, Illinois. *Nat.-Gas Journ.*, vol. v, no. 3, pp. 17-21. [1911.]
801. ———— Oil Investigations in Illinois. *Journ. West. Soc. Eng.*, vol. xvi, pp. 369-396, 3 pls. [1911.]
802. ———— Petroleum in Illinois in 1910, 1911. *Eng. Min. Journ.*, vol. xci, pp. 92, 93; vol. xciii, p. 95. [1911, 1912.]
803. **Blatchley, W. S.** The Petroleum Industry in Indiana in 1896-1908. *Ann. Rep. Indiana Geol. Surv.*, vols. xx-xxxiii. [1897-1909.]
804. ———— The Petroleum Industry of Southeastern Illinois. *Bull. Geol. Surv. Illinois*, no. 2. Pp. 109; 6 pls. [1906.]
805. ———— The Princeton Petroleum Field of Indiana. *Ann. Rep. Indiana Geol. Surv.*, vol. xxxi, pp. 559-593, map. [1907.]
806. **Blatchley, W. S.**, and **W. H. Streak.** Trenton Rock Petroleum. *Sci. Amer. Suppl.*, vol. iv, p. 22, 776. [1903.]

807. Blau, C. Gegenwärtige Lage der Montan-Industrie in Russland. *Russ. Rev.*, bd. xxx, pp. 149-182, 2<sup>te</sup> 791. [1891.]
808. Blauhorn, J. Das Recht der Rohölgewinnung in Oesterreich. *Berlin*, 1910.
809. Blazy, A. Notes sur l'île Tchéléque. *Journ. Pét.*, t. ii, pp. 33, 34, 50-52, 75-77. [1902.]
810. ——— Le Pétrole à Bakou et les Intérêts français au Caucase. 8vo, Paris, 1902.
811. ——— [Motive Power in the Baku Oilfield.] *Monit. Ind. Pétrol. Roum.*, t. vii, pp. 38-41. [1906.]
812. Bleekrode, S. De Aard-, Berg- of Steenolie (Minjak Lantoeing) in Nederlandsch Indie. *Nieuw Tijdschr. Volkswijst*, dl. v, pp. 166-184. [1861.]
813. Bleiberg, J. Zur Bestimmung des Oelgehaltes in Paraffin-schuppen von Dr. Leo Neustadtl. *Chem.-Zeit.*, bd. xxx, p. 102. [1906.]
814. Bleicher, —. Sur nouveaux gisements pétrolières de l'Alsace. *Bull. Soc. Sci. Nancy*, ser. 2, t. vi, pp. xxxv, xxxvi. [1883.]
815. Bleichroder, S. Le développement de l'industrie du pétrole en Roumaine. 8vo, Bucharest, 1907.
816. Bley, L. F. Ueber Braunkohlenöl und ein bei der trocknen Destillation von Braunkohlen erhaltenes Harz. *Ann. Chem. Pharm.*, bd. ix, pp. 294, 295. [1834.]
- Blinks, W., see Noyes, W. A.
817. Bloch, —. Grundzüge der Beleuchtungstechnik. 8vo, Berlin, 1909.
818. Blöde, K. A. Dysodil oder Stinkkohle. *Schr. Ges. Min. Dresden*, bd. ii, pp. 34-37. [1819.]
819. Bloomer, A. P. [Petroleum-Fuel.] *St. Petersburg*, 1888.
820. Blount, B. The Composition of Commercial Petrols. *Proc. Inst. Automob. Eng.*, n.s., vol. iii, pp. 301-324. [1909.]
821. Blue, A. Reports of the Bureau of Mines, Ontario, nos. 1, 6-8. 8vo, Ottawa, 1892-1899.
- Bluman, N. J., see Griffiths, A. B.
822. Blunt, J. E. Reports for the years 1885-1885, 1887, 1888 on the Trade of the District of Salonica. *Dipl. Cons. Rep.*, ann. ser., nos. 24, 75, 394, 623 [1886-1889.]
823. Bobrzynski, J. Ueber ein Erdöl aus Fergana. *Petroleum Zeitschr.*, bd. vi, pp. 485, 486. [1911.]
824. Boccone, P. Account of some Natural Curiosities [Sicilian Bitumen, etc.] presented to the Royal Society. *Phil. Trans.*, vol. viii, p. 6158. [1673.]
825. ——— Osservazioni naturali attorno i fuochi sotterranei osservati nel Modenese. *Bologna*, 1684.
826. ——— Musaeo di Fisica, e di esperienze decorato di osservazioni naturali. 4to, Venice, 1697.
827. Bochart, S. Geographia Sacra. Caen, 1646.
828. Bochet, A. Application des Moteurs à Pétrole à la Navigation. *Mém. Soc. Ing. Civ.*, 1903, t. lvi, pp. 877-888, pl. 54.
829. Bochman, —. Einiges über den Bergbau und Ozokerit in und um Boryslaw in Galizien. *Zeitschr. Paraff. Ind.*, 1879, p. 51.
830. Bock, J. v. Die Steinkohlen-, Torf- und Naphta-Gewinnung in Russland in den Jahren 1860-1871. *Russ. Rev.*, 1874, pp. 30-52.
831. Bodart, M. Appareils servant à mesurer la déviation des sondages et leur application dans les creusements de puits. *Rev. Univ. Min.*, ser. 4, t. xxii, pp. 216-237. [1910.]
832. Bodde, D. An Essay, to show that Petroleum may be used with advantage in Manufacturing Operations, for the purpose of heating Steam-boilers and Generating Steam. 8vo, The Hague, 1865.
833. Bode, Baron C. A. de. Travels in Luristan and Arabistan. 2 vols. 8vo, London, 1845.
834. Bodenbender, G. Sobre el Terreno Jurassico y Cretaceo en los Andes Argentinos entre el río Diamante y el río Limay. *Bol. Ac. Nac. Ci. Córdoba*, t. xiii, pp. 5-44, 2 pls. [1893.]
835. ——— Sobre el Carbon y Asfalto Carbonizado de la Provincia de Mendoza. *Ibid.*, pp. 152-170. [1893.]
836. Böckh, H. Ueber den Fichtelit. *Földt. Kozl.*, köt. xxxiv, pp. 369, 370 (Magyar, pp. 336, 336). [1904.]
837. ——— [On the Gas-yielding Anticlinal of the Transylvanian Basin. Report on the Researches into the Occurrence of Natural Gas in the Transylvanian Basin.] Part I, pp. 1-86; 2 pls. 8vo, Budapest, 1911.
838. Böckh, J. Daten zur Kenntniss der geologischen Verhältnisse im oberen Abschnitte des Iza-Thales mit besonderer Berücksichtigung der dortigen Petroleum-führenden Ablagerungen. *Mitth. Jahrb. k.-ung. geol. Anst.*, bd. xi, pp. 1-93, pl. [1897.]
839. ——— Die geologische Verhältnisse von Sosmezo und Umgebung in Comitata Haromszek, mit besonderer Berücksichtigung der dortigen Petroleum-führenden Ablagerungen. *Ibid.*, bd. xii, pp. 1-223, pl. 1 (map 1 : 75,000). [1900.]
840. Böckh, J., and A. Gesell. Die in Betrieb stehenden und im Aufschlusse begriffene Lagerstätten von Edelmetallen, . . . und anderen nutzbaren Mineralien auf dem Territorium der Länder der Ungarischen Krone. Budapest, 1898.
841. Böckler, J. Cynosura Materiae Medicae continuata ad Cynosurae Materiae Medicae Hermannianae imitationem collecta. 4to, Strassburg, 1729.
842. Böckmann, F. Chemisch-technische Untersuchungsmethoden der Gross-Industrie, der Versuchsstationen und Handelslaboratorien. Berlin, 1884.
843. Bödeker, —. Report on the Trade of the Consular District of Caracas for the year 1905. *Dipl. Cons. Rep.*, ann. ser., no. 8657. [1906.]
844. Bödeker, C. Ueber das Idryl und das Idrialin. *Ann. Chem. Pharm.*, bd. lii, pp. 100-106. [1844.]
845. Böhm, C. On Crude Petroleum (Greek-Fire) Equipments for Purposes of Naval Warfare. *Trans. Inst. Naval Archit.*, vol. xix, pp. 232-240. [1878.]
846. Böhm, F. [Description of the Deep Boring in the Sarnas District. Report on the Researches into the Occurrence of Natural Gas in the Transylvanian Basin.] Part I, pp. 37-72. 8vo, Budapest, 1911.
847. Böhm, G. Beiträge zur geognostischen Kenntniss der Hilsmulde. *Zeitschr. deutsch. geol. Ges.*, bd. xxix, pp. 215-251. [1877.]
848. Böhm, M. Beiträge zur Kenntniss des Galizischen Erdöles. 8vo, Vienna, 1884.
849. Böhm, M., and R. Turgensen. Das Naphta-Gebiet von Baku. *Zeitschr. Paraff. Industr.*, 1886, pp. 11-16.
- Böhm, M., see Engler, C.
850. Böhme, R. Ueber die Bestimmung im Petroleum, Petroldestillaten und Benzol, im Terpentintöl, Kienöl, und in Terpentinübersatzmitteln. *Chem. Zeit.*, bd. xxx, pp. 633-635. [1906.]
851. Böhnke Reich, H. [Ozokerite or Mineral-wax.] *Rep. anal. Chem.*, bd. v, pp. 353, 354. [1885.]
852. Böke, J. D. Het natuur- of brongas in den bodem van Nederland. *De Natuur*, dl. xvi, pp. 82-89. [1896.]
853. Boerhaave, H. Elementa Chemiae. 8vo, Leyden, 1724.
854. Börnstein, —. Petroleum. In Daumer's "Handwörterbuch der öffentlichen und privaten Gesundheitspflege." Stuttgart, 1890.
- Börnstein, E., see Landolt, H. H.
855. Boes, J. Ueber das Thionaphten des Braunkohlenteers. *Apoth.-Zeit.*, bd. xvii, p. 565. [1902.]
856. Böse, E. Reseña acerca de la Geologia de Chiapas y Tabasco. *Bol. Inst. Geol. Mexico*, no. 20. [1905.]
- Bötcher, W., see Krämer, G.
857. Böttger, —. Einfache Methode, das kiefliche Steinöl ohne Destillation vollkommen wasserhell zu machen. *Ann. Chem. Pharm.*, bd. xxv, pp. 100, 101. [1838.]
858. Bouévilé, E. L'Extraction d'Huiles minérales dans la province d'Hanovre. *Journ. Pétrole*, ann. v, pp. 101-103. [1905.]
859. Bogatchev, V. I. [Vessels for keeping Petroleum. *Zap. Kavk. Old. Russk. Tekhn. Obsch.*, t. i, no. 10, pp. 25-27. [1869.]

860. **Bogatchev, V. I.** [Report on the Combustion of Oil.] *Zap. Kavk. Otd. Russk. Tekhn. Obsch.*, t. iii, p. 251. [1871.]
861. ——— [Gas at Tiflis.] *Ibid.*, t. iv, pp. 417-424. [1872.]
862. ——— [Report on the Vienna Universal Exhibition of 1874.] *Ibid.*, t. vi, pp. 180-191. [1874.]
863. ——— [Comparison of Petroleum and Wood as Railway Fuel.] *Ibid.*, t. xii, pp. 75-79. [1880.]
864. **Bogdanovitch, K. I.** [Transcaspia and North Persia.] *Verh. russ.-k. min. Ges.*, f. 2, bd. xxvi, pp. 1-156, and French résumé, pp. 157-192. [1890.]
865. ——— [Expedition to Central Asia.] *Gorn. Journ.*, 1892, t. 2, pp. 84-157; pl. iv.
866. ——— [Economic Minerals and Geology of the Irkutsk Government (Siberia).] *Ibid.*, 1895, t. 4, pp. 15-106, 199-290, 357-454, 8 pls.
867. ——— [Two Ascents of the Main Range of the Caucasus.] *Mém. Com. géol. Russ.*, t. xix, no. 1. Pp. xxviii, 209; 3 pls., map. [1902.]
868. ——— [Geological Researches in the Kuban Oil Field, Khadjin Sheet.] *Ibid.*, n.s., no. 57. Pp. iv, 78; map. [1910.]
869. **Bogdanovitch, K. I., K. I. Kalitzki, D. V. Golubyatnikov, and S. I. Tcharnotzki.** [Report on the Productivity of Bibi-Eibat.] *Bull. Com. géol. Russ.*, t. xxix, Journ., pp. 297-307. [1910.]
870. **Bogdanovitch, K. I., and P. I. Polevoi.** [Economic Minerals of Northern Sakhalin.] *Ibid.*, t. xxviii, Journ., pp. 23-26. [1909.]
871. **Bogushevski, A. A.** [Cement-lining of Oil Wells.] *Gorn. Journ.*, 1908, t. 4, pp. 1-30, 3 pls.
- Boileau, G.** —, see **Gauldrée-Boileau**, —.
872. **Bokelberg**, —. Vorkommen, Gewinnung und Entstehung des Erdöls. *Wochenschr. Ver. deutsch. Ing.*, 1881, pp. 247-249.
873. **Boklevski, P.** [On the Illuminating Gas Compound with Air for Lighting and Heating.] Pp. 40. *Moscow*, 1878.
874. ——— [Petchora Petroleum.] Pp. 31, map. *St. Petersburg*, 1891.
875. ——— [Mining and Metallurgy in the Nijni-Novgorod Exhibition. Fasc. ii, gr. vi.] *St. Petersburg*, 1897.
876. **Bolevi**, —. [Journey across Russia into Asiatic Territories.] *St. Petersburg*, 1776.
877. **Bolles, A. S.** Industrial History of the United States. *Norwich, Conn.*, 1879.
878. **Bolley, P. A.** Ueber die produkte der Einwirkung von Chlor auf Paraffin. *Ann. Chem. Pharm.*, bd. cvi, pp. 230-235. [1858.]
879. ——— Paraffin, fertig gebildet in Bogheadschiefer. *Schweiz. polyt. Zeitschr.*, bd. v, p. 55. [1860.]
880. ——— On a hitherto unobserved Source of Paraffin. *Journ. Chem. Soc.*, vol. xiii, pp. 329, 330. [1861.]
881. ——— Chemisch-technische. Untersuchungen über das amerikanische Petroleum. *Schweiz. Polyt. Zeitschr.*, bd. viii, pp. 96-102. [1863.]
882. ——— Zur Chemie und Technik der Fette. *Polyt. Journ.*, bd. clxxxix, pp. 463-476. [1866.]
883. ——— Ueber einige neue Eigenschaften des Paraffins und die Paraffinbäder. *Schweiz. Polyt. Zeitschr.*, bd. xiii, pp. 65-67. [1868.]
884. **Bolton**, —. [Siemens' Control-apparatus for production of Photogen from Petroleum.] *Zap. Kavk. Otd. Russk. Tekhn. Obsch.*, t. vii, pp. 91-94. [1875.]
885. **Boltze, H.** Ueber die Art und Weise des Vorkommens von Schwärzkohlen in der Prov. Sachsen. *Zeitsch. gesamm. Nat.*, bd. xlix, pp. 173-214, pl. 5. [1877.]
886. **Bombicci, L.** Montagne e Vallati del Territorio di Biogola. *Bologna*, 1832.
887. **Bonarelli, G.** Manifestazioni petrolifere dans le Sud de l'Espagne. *Giorn. Geol. prat.*, t. vii, pp. 135-137, pl. [1909.]
888. **Bone, J. H. A.** Petroleum and Petroleum Wells. Guide-book and description of the Oil Regions of Pennsylvania, West Virginia, and Ohio. *Philad. and New York*, 1865.
889. **Bone, W. A.** The Combustion of Hydrocarbons. *Proc. Inst. Automob. Eng.*, n.s., vol. i, pp. 7-35. [1906.]
890. **Bone, W. A.** Reports of the Committee appointed for the investigation of Gaseous Explosions, with special reference to Temperature. *Rep. Brit. Assoc. for 1908*, pp. 308-341; 1909, pp. 247-270; 1910, pp. 199-227; 1911, p. 130. [1909-1912.]
891. **Bone, W. A., and H. F. Coward.** The Thermal Decomposition of Hydrocarbons. Part I (Methane, Ethane, Ethylene, and Acetylene). *Journ. Chem. Soc.*, vol. xxiii, pp. 1197-1225. [1908.]
892. **Bone, W. A., and D. S. Jerdan.** The Direct Union of Carbon and Hydrogen. *Journ. Chem. Soc.*, vol. lxxi, pp. 41-61; vol. lxxix, pp. 1042-1063. [1897, 1901.]
893. **Bone, W. A., and W. E. Stockings.** The Slow Combustion of Ethane. *Ibid.*, vol. lxxxv, pp. 693-727. [1904.]
894. **Bone, W. A., and R. V. Wheeler.** The Slow Oxidation of Methane at Low Temperatures. *Ibid.*, vol. lxxxi, pp. 535-549. [1902; vol. lxxxiii, pp. 1074-1087. [1903.]
895. ——— The Combustion of Ethylene. *Ibid.*, vol. lxxxv, pp. 1637-1663. [1904.]
- Bone, W. A.**, see **Dixon, H. B.**, and **Lean, B.**
896. **Bonfoli-Malvezzi, A.** Intorno ai fuochi di Pietramala. 1777.
897. **Bong, Gaston.** Sur les résidus de la fabrication des huiles de Schistes. *Bull. Soc. Chim. Paris*, sér. 2, t. xxvii, pp. 147-149. [1880.]
898. **Bonneville, B. L. E.** The Rocky Mountains, or Scenes, Incidents, and Adventures in the Far West; digested from the Journal of Capt. B. L. E. B., by Washington Irving. *Philadelphia*, 1837.
- Bonpland, A.**, see **Humboldt, F. H. A. v.**
899. **Boodle, L. A.** N'hangelite and Coorongite. *Bull. R. Bot. Gardens, Kew*, 1907, pp. 145-151.
900. **Boorman, T. H.** Asphalts, their Sources and Utilisations. 8vo, *New York*, 1908.
901. ——— Bitumen and Oils in West Africa. *Eng. Min. Journ.*, vol. lxxxvii, p. 1037. [1909.]
902. **Booth, Jas. C., and T. H. Garrett.** Experiments on Illumination with Mineral Oils. *Journ. Franklin Inst.*, vol. lxxlii, pp. 373-380. [1862.]
903. **Booth, W. H.** Liquid Fuel and its Combustion. 8vo, *London*, 1903.
904. ——— The Elmore Process of Concentration by Oil. A method adapted for saving finely divided floating particles of ore or metal (sulphuret ores). *Mines and Minerals*, vol. xxiii, pp. 292, 293. [1903.]
905. ——— Notes on Liquid Fuel. *Proc. Assoc. Eng. in Charge*, no. 4. [1903.]
906. ——— Water and Petroleum Boring and Machinery. *Ibid.*, vol. xvi, no. 6. [1911.]
907. ——— Liquid Fuel and its Apparatus. 8vo, *London*, 1912.
908. ——— What Oil will do in the Internal Combustion Engine of Diesel Type. *Petrol. Rev.*, vol. xxv, pp. 97, 145, 146. [1911.]
909. ——— Venezuela, its resources, etc. *Cassier's Mag.*, vol. xl, pp. 226-243. [1911.]
910. **Borelli, F.** Le Pétrole dans l'Ohio et l'Indiana. *Journ. Pétrol.*, t. v, pp. 379-381. [1905.]
911. **Boricky, E.** Perinorphenen einer asphaltähnlichen Substanz nach Calcit. *Lotos*, Feb. 1869.
912. ——— Fichtell von Borkovic (im Tábor.-K.). *Sitz. k. böhm. Ges. Wiss.*, 1870, pp. 42, 43.
913. ——— Ueber den Anthracide des oberen Silurgebietes in Böhmen. *Sitz. k. böhm. Ges. Wiss.*, 1873, p. 2.
914. **Borisyak, A.** [Mud-volcano near Vladislavov, Crimea.] *Bull. Com. géol. Russ.*, t. xxvi, Journ., pp. 34-36. [1907.]
915. **Born**, — de. Catalogue méthodique et raisonné de la Collection des Fossiles de Mlle. Elconore de Raab. 8vo, *Vienna*, 1790.
916. **Bornemann, E.** Asphaltuntersuchung. *Asphalt-Teerind.-Zeit.*, bd. vii, pp. 528, 539. [1907.]
917. ——— Eine neue Methode zur Bestimmung des Bitumengehaltes in Stampfasphaltmehlen. *Chem.-Zeit.*, bd. xxxi, p. 500. [1907.]

918. **Bornemann, E.** Zur Analyse von Asphaltprodukten. *Chem.-Zeit.*, bd. xxxiii, pp. 1225, 1226. [1909]
919. **Bornemann, G.** Fette und Oele. *Chem. Rev. Fett-Harz-Ind.*, bd. x, pp. 100-102, 128-130, 149-151. [1903]; bd. xi, pp. 93, 94. [1904.]
920. — Fortschritte auf dem Gebiete der Petroleumindustrie im Jahre 1908. *Chem.-Zeit.*, bd. xxxiii, pp. 793-795, 802-805. [1909]
921. **Bornhardt, W.** Ueber die Erdöl-Vorkommnisse in der östlichen Umgebung der Stadt Braunschweig. *Beitr. Geol. Pal. Braunschweig*, bd. i, pp. 61-100, 3 pls. [1894.]
922. **Borotschi de Els.** — [On an Eruption of Boz-Tepe in the Baku Province.] *Gorn. Journ.*, 1830, t. 2, pp. 405-409.
923. **Borrmann, C. H.** Das Destillationsverfahren Kubierschky. *Petroleum Zeitschr.*, bd. vi, pp. 2303-2305. [1911.]
924. **Borsig, A.** Ein einfaches Mittel zur Verhütung des Verschlammes resp. Versandens von Bohr- und Tiefbrunnen. *Naphta*, bd. ix, pp. 368-370. [1901.]
925. **Borstelmann, P.** [Testing of Lubricating Oils.] *Protok. St. Petersb. Polyt. Ver.*, 1904, p. 82.
926. **Bosis, F. de.** I Minerali utili delle Marche. *Atti Soc. Ital. Sci. Nat.*, vol. iii, pp. 227-333. [1861.]
927. **Bosset, G. de.** De l'asphalte et des mines du Val de Travers. *Neuchâtel*, 1838.
928. **Bossung, E.** Ueber das Erdöl von Montechino [Piaccenza]. *Karlsruhe*, 1832.
929. **Bostaph, H. P.** Nitroglycerine and the Shooting of Oil Wells. *Petrol. Rev.*, vol. xxii, pp. 255, 256. [1910]
930. **Both, E.** Untersuchung eines Erdöles aus der Kergisensteppe. *Pharm. Zeitschr. Russl.*, bd. viii, pp. 467-469. [1869.]
931. **Botsford, C. W.** Geological Notes on West Coast of Mexico. *Eng. Min. Journ.*, vol. lxxxix, pp. 223, 224. [1910.]
- Boudaroy, A. D. F. de,** see **Fougeroux de Boudaroy, A. D.**
932. **Boué, A.** La Turquie d'Europe. 4 Tt. *Paris*, 1840.
933. **Bouillet, J.** Mémoires sur l'huile de pétrole et les eaux minérales de Gabian. *Béziers*, 1752.
- Boulanger,** —, see **Farez,** —.
934. **Boulanger, E.** Voyage à Merv. 16mo, 1838.
935. **Boulinier,** —. Un Gisement de Bitume de formation Contemporaine [Venezuela]. *Bull. anc. Et. Ecole Mines Paris*, 1909.
936. **Boulton, H. L.** Report for the year 1894 on the Trade of the Consular District of Caracas. *Dipl. Cons. Rep.*, ann. ser., no. 1602. [1895.]
937. **Bouret, A.** Lampe à essence minérale à double alimentation. *Journ. Pétrole*, t. iv, p. 76. [1904.]
938. **Bourgeois, H.** L'emploi de l'électricité dans les Exploitations Pétrolières Russes. *Ibid.*, t. vi, pp. 229-231. [1906.]
939. **Bourgougnon, A.** Pennsylvania Petroleum. *Proc. Amer. Chem. Soc.*, vol. i, pp. 91-96. [1876.]
940. — Determination of Naphtha in Crude Petroleum. *Ibid.*, vol. i, pp. 119-121. [1877.]
941. — Petroleum and its Examination. *Journ. Amer. Chem. Soc.*, vol. i, pp. 188-204. [1879.]
- Bourgougnon, A.,** see **Mandel, J. A.**
942. **Bourjot,** —. Note sur le gisement des schistes bitumineux à impressions de végétaux de Menat; sur la chaleur présumable d'un dyke basaltique, non venu au jour, au point où une partie de ces schistes a été transformée en tripoli par la chaleur souterraine; considérations générales sur ce sujet. *Bull. Soc. Géol. France*, sér. 2, t. viii, pp. 39-44. [1850.]
943. **Bourqui, C.** Le soufre dans les pétroles roumains. *Journ. Pét.*, t. i, pp. 99, 100. [1901.]
944. **Bousquet, J. G.** Les richesses minérales des Indes Orientales Néerlandaises. *Mém. Soc. Ing. Civ.*, ann. lvii, pp. 436-496. [1904.]
945. **Boussingault, J. B.** Sur la composition des Bitumes. *Compt. Rend.*, t. iii, pp. 375-378. [1836.]
946. **Boussingault, J. B.** Sur le Bitume de Bechelbrunn. *L'Institut*, 1837, no. 176.
947. — Analyse de quelques substances bitumineuses. *Ann. Chim. Phys.*, sér. 2, t. lxxiii, pp. 442-445. [1840.]
948. — Rapport sur des échantillons d'Eau Salée et de Bitume envoyés de la Chine par M. Bertrand. *Compt. Rend.*, t. xxii, pp. 667-669. [1846.]
949. — Sur la composition des substances minérales combustibles. *Ann. Chim. Phys.*, sér. 5, t. xxix, pp. 363-392. [1833.]
950. **Boutigny, P. H.** Etudes sur les corps à l'état sphéroïdal. 8vo, *Paris*, 1842.
951. **Boutwell, J. M.** Oil and Asphalt Prospects in Salt Lake Basin, Utah. *Bull. U.S. Geol. Surv.*, no. 260, pp. 468-479. [1905.]
952. **Bowen, E.** Coal and Coal Oil. 12mo, *Philadelphia*, 1865.
953. **Bower, G.** Gas from Petroleum-Oil, and from Wood and Peat enriched with Oil. *Journ. Gaslight*, vol. xii, pp. 516, 517. [1863.]
954. **Bower, John.** Whitty Jet and its Manufacture. *Journ. Soc. Arts*, vol. xxii, pp. 80-87. [1874.]
955. **Bowers, S.** Orange County. 10th Ann. Rep. State Mineral. Calif., for 1890, pp. 339-409. [1890.]
956. — Ventura County. *Ibid.*, pp. 758-762. [1890.]
957. — Reconnaissance of the Colorado Desert Mining district. *California State Min. Bur.*, 1901, 12 pp.
958. — Peculiar Features of the Geology of McKittrick [California]. *Petroleum*, vol. ii, p. 668. [1902.]
959. **Bowie, C. P.** Pumping California Petroleum. *Oil Age*, 1911.
960. **Bowman, F. C.** The Use of Crude Oil for Fire-Assaying. *Proc. Colorado Sci. Soc.*, vol. vii, pp. 341-346. [1904.]
961. **Bowman, I.** Disposal of Oil-Well Wastes at Marion, Ind. *Water-Supply Papers, U.S. Geol. Surv.*, no. 113, pp. 36-52, pl. [1905.]
962. — History of Drilling and Deep Well Record. *Petr. Rev.*, vol. xxv, pp. 239, 240, 275, 276. [1911.]
963. **Bownocker, J. A.** The Corning Oil and Gas Field. *Ohio Nat.*, vol. i, pp. 49-59. [1901.]
964. — The Oil- and Gas-Producing Rocks of Ohio. *Journ. Geol. Chicago*, vol. x, pp. 822-838. [1902.]
965. — The Central Ohio Natural Gas Fields. *Amer. Geol.*, vol. xxxi, pp. 218-231, map. [1903.]
966. — The Occurrence and Exploitation of Petroleum and Natural Gas in Ohio. *Bull. Geol. Surv. Ohio*, no. 1. (= *Ann. Rep. State Geol. Ohio*, vol. viii.) 8vo, *Columbus*, 1903.
967. — Geology as applied to the Formations in which Natural Gas is found in the Appalachian regions. *Progressive Age*, vol. xxvii, pp. 541-544. [1909.]
968. — The Bremen Oil Field, Ohio. *Bull. Geol. Surv. Ohio*, ser. 4, no. 12. Pp 68; 6 pls. [1910.]
969. — The Clinton Sand as a Source of Oil in Ohio. *Econ. Geol.*, vol. vi, pp. 37-50. [1911.]
970. **Boyd, C. B.** The Indiana Natural Gas Field. *Eng. Min. Journ.*, vol. lv, pp. 440, 441. [1893.]
971. **Boyd, E. F.** Remarks on the Coal-measures and Oil-produce of the United States. *Trans. N. Engl. Inst. Eng.*, vol. xxv, pp. 145-167, pls. xliii-xlix. [1876.]
972. **Boyd, R. N.** Boring for Petroleum in Galicia, Austria. *Trans. Civ. Mech. Eng. Soc.*, 1888-1889, pp. 36-44. [1889.]
973. — The Origin of Petroleum. *Coll. Guard.*, vol. lxx, p. 554. [1895.]
974. — Petroleum, its Development and Uses. 8vo, *London*, 1895.
975. **Boyea, E. v.** Zur Raffinirung schwerer Paraffinöle des Braunkohlentheers. *Chem.-Zeit.*, bd. xiv, pp. 267-269, 289-291. [1891.]
976. — Paraffin und Bitumen des Braunkohlentheers. *Zeitschr. angew. Chem.*, bd. iv, pp. 101-104, 261-265. [1891.]



977. **Boyer, E. v.** Beiträge zur Ceresinfabrikation. *Zeitschr. angew. Chem.*, bd. vi, pp. 414-420, 448-450, 581-590, 601-607. [1893.]
978. — Zur Werthbestimmung des galizischen Ozokerits. *Ibid.*, bd. xi, p. 283. [1895.]
979. — Ueber Montanwachs. *Ibid.*, bd. xiv, pp. 1110, 1111. [1901.]
980. **Boyer, E., L. Cavaillon, et N. Barishac.** Procédé de préparation d'huiles de graissage à base d'huile de ricin et d'huiles minérales. *Journ. Petr.*, t. ix, p. 106. [1909.]
981. **Boyer, J.** Le Pétrole en Roumanie. *La Nature*, Feb. 1905.
982. **Boyle, A.** Account of an eruption off False Island, Ramree. *Journ. As. Soc. Beng.*, vol. xlii, p. xxxv. [1814.]
983. **Brackebusch, L.** Estudios sobre la formación petrolífera de Jujuy. *An. Soc. Cient. Argent.*, t. xv, pp. 19-58. [1883.]
984. — Die Bergwerksverhältnisse der Argentinischen Republik. *Zeitschr. Berg. Hüt. Salinenw.*, bd. xii, pp. 15-47. [1893.]
985. — Die Erdöl- und Kali-Industrie Norddeutschlands. *Petroleum Zeitschr.*, bd. i, pp. 329-331. [1906.]
986. **Bradley, W. P., and C. F. Hale.** The Relation between the Temperature of Kerosene and the Explosion Pressure of the Supernatant Mixture of Air and Vapor. *Journ. Ind. Eng. Chem.*, vol. i, pp. 345-351. [1909.]
987. **Brady, F. W.** Oilfield on Buffalo Creek (W. Va.). *Mines and Minerals*, vol. xviii, p. 187-189. [1907.]
988. — Oil Field at Follamsbee, W. Va. *Ibid.*, vol. xxix, pp. 207-209. [1908.]
989. — Making Gasoline from Oil Well Gas. *Ibid.*, vol. xxxii, pp. 49-52. [1911.]
990. **Bramall, H.** The Mineral Resources of New Zealand. *Proc. Liverpool Geol. Assoc.*, vol. iii, pp. 72-92, 102-136, map. [1883.]
991. **Brame, J. S. S.** Liquid Fuel and its Economic Aspects. *Petrol. Rev.*, vol. xxi, p. 237. [1909.]
992. **Branco, W.** Ueber H. Höfers Erklarungsversuch der hohen Wärmezunahme im Bohrkolze zu Neuffen. *Zeitschr. deutsch. geol. Ges.*, bd. lvi, Briefl. Mitth., pp. 174-182. [1905.]
993. **Branner, J. C.** The Oil-Bearing Shales of the Coast of Brazil. *Trans. Amer. Inst. Min. Eng.*, vol. xxx, pp. 537-554, map. [1901.]
994. **Branner, J. C., J. F. Newsome, and R. Arnold.** Santa Cruz, Cal. Fo. 163, *U.S. Geol. Surv.*, 1909.
995. **Brannt, W. T.** A Practical Treatise on the Manufacture of Soap and Candles. 8vo, Philadelphia, 1888.
996. — A Practical Treatise on Animal and Vegetable Fats and Oils; . . . including Mineral Lubricating Oils, etc., and on Ozokerite. Philadelphia, 1888. Ed. ii., 1896.
997. — Petroleum; its History, Origin, Occurrence, Production, Physical and Chemical Constitution, Technology, Examination, and Uses. Philadelphia and London, 1895.
- Bransky, O. E., see Gilpin, J. E.**
998. **Branthome, —.** Analyse des houilles de Sundsweyer, Saarbrück, Rodern, Lalaye, Loysan et Bouxweiler. *Journ. Mines*, t. xxviii, pp. 363-378. [1810.]
999. **Bratianu, V. I., see Alimanesianu, H. C.**
1000. **Bratmann, —.** [Formation of Petroleum.] *Wszecznosc*, 1894, no. 16.
1001. **Braun, O.** Ueber einige neuere Apparate zur Prüfung des Petroleums auf seine Entzündlichkeit. *Sitz. Ver. Beförd. Gewerbb.*, 1881, pp. 212-216.
1002. **Brauns, D.** Der obere Jura im nordwestlichen Deutschland von der oberen Grenze der Ornatschichten bis zur Wealdbildung, mit besonderer Berücksichtigung seiner Molluskfauna. 8vo, Braunschweig, 1874.
1003. **Bravo, J. J., see E. J. Duenas.**
1002. **Breger, C. L.** Origin of Lander Oil and Western Phosphate. *Mining Eng. World*, Sept. 30, 1911.
1003. **Breislak, S.** Topografia Fisica della Campania. 8vo, Florence, 1798.
1004. — Voyages physiques et lithologiques dans la Campanie. 8vo, Paris, 1801.
1005. **Breitenlohner, J. J.** Das Paraffin, dessen Aufbereitung aus Torfheer und Verwendungsarten. *Polyt. Journ.*, bd. cxlxi, pp. 59-71. [1864.]
1006. **Breithaupt, A.** [Manufacture of Mineral Oil in the Weissensfeld District.] *Verh. Bergmann. Ver. Freiberg*, Oct. 6, 1863.
1007. **Bremer, G. J. W.** Der Entflammungspunkt von Petroleum. *Zeitschr. angew. Chem.*, bd. ix, pp. 494-497. [1896.]
1008. **Bremer, J. N.** Anzeige über das brennbare Gas. *Ann. Phys. Chem.*, bd. vii, pp. 131-134. [1826.]
1009. **Bremond, F.** Note sur les ouvriers employés dans les raffineries de pétrole. *Rev. Hygiène*, 1895, p. 166.
1010. **Brenan, B.** Reports for the years 1893, 1894 on the Trade of Macao and Timor. *Dipl. Cons. Rep.*, ann. ser., nos. 1457, 1637. [1894, 1895.]
1011. **Brenken, O.** Ueber die Untersuchung der mineralischen Schmieröle. *Zeitschr. anal. Chem.*, bd. xviii, pp. 546-552. [1879.]
1012. **Brent, C.** Notes on Oil Furnaces for Assaying and Melting. *Journ. Canad. Min. Inst.*, vol. v, p. 288. [1902.]
1013. **Breslau, —.** Ueber das Vorkommen des Ozokerits auf dem Wettiner Steinkohlenreviere. *Arch. Min. Geogn.*, bd. xxiii, pp. 749-761. [1850.]
1014. **Breslau, W.** Report for the year 1888 on the Trade of the District of Riga. *Dipl. Cons. Rep.*, ann. ser., no. 516. [1889.]
1015. **Breth, F.** Die Paraffinzerzeugung aus Borsylaw Rohöl. *Allg. österr. Chem.-Techn.-Zeit.*, bd. xxvi, p. 78. [1908.]
1016. — Die wichtigsten Eigenschaften des Paraffins. *Seifensied. Zeit.*, bd. xxxvii, pp. 292, 293, 335, 336. [1910.]
1017. — Ueber den Einfluss der Probenahme auf die Bestimmung des Stockpunktes von Paraffin. *Petroleum Zeitschr.*, bd. vii, pp. 106, 107. [1911.]
1018. — Zur Kenntnis des Transformatoröles. *Ibid.*, pp. 290, 291. [1911.]
1019. **Breuil, P.** Notes sur quelques essais mécaniques et viscosimétriques d'huiles minérales ou végétales. *Bull. Conservat. Arts Métiers*, no. 6. Pp. 24, pl. [1906.]
1020. **Breukerveen, M. v.** Sur la composition des gaz se dégageant de l'eau d'un puits près d'Enkhuizen (Hollande septentrionale). *Rec. Trav. Chim. Pays-Bas*, t. xv, pp. 280, 281. [1896.]
1021. **Brevern, —.** [Results of Researches on the Sources and Luminosity of Petroleum Gas from the Oil of Tsarski-Kolodisi and Navtuga.] *Zap. Kaek. Otd. Imp. Russk. Tekhn. Obs'h.*, t. iv, pp. 463-469. [1872.]
1022. **Brewer, R. W. A.** Liquid Fuel for Internal Combustion Engines. *Gas and Oil Eng. Rec.*, vol. v, pp. 637-639, 646, 647, 675, 676. [1907.]
1023. **Brewster, D.** Account of the Atash-Kudda or Natural Fire-Temples of the Gnebres, formed by Burning Springs of Naphtha, with a Notice respecting the Naphtha Wells in Pegu. *Edinb. Phil. Journ.*, vol. v, pp. 21-27. [1821.]
1024. **Briart, A.** Principes élémentaires de Paléontologie. 8vo, Mons, 1883.
1025. — Sur la présence d'un Hydro-carbure liquide dans l'Etage Houiller du Hainaut. *Ann. Soc. Géol. Belg.*, t. xv, pp. cxxxii-cxxxvi. [1888.]
1026. **Briggs, R.** [Venango County Oil Region.] *Proc. Amer. Phil. Soc.*, vol. x, pp. 109, 110. [1865.]
1027. **Bright, R.** On the Strata in the Neighbourhood of Bristol. *Trans. Geol. Soc.* (ser. 1), vol. iv, pp. 193-204. [1817.]
1028. **Briguoli, G. de.** Relazione accademica dell'eruzione della Salsina di Sassuolo. *Reggio-Emilia*, 1836.
1029. **Brives, A.** Sur la Géologie de la Région Pétrolière des Environs de Relizane. *Bull. Soc. Géol. France*, sér. 3, t. xxvii, p. 128. [1899.]

1030. **Brives, A.** Géologie des Terrains Pétrolifères de Relizane (Algérie). *Compt. Rend. Assoc. Franç.*, sess., xxx, pt. 1, p. 115. [1902.]
1031. **Brix, A. F. W.** Ueber die Anfertigung von Troittoirplatten aus bituminösem Mastic. *Verh. Ver. Beford. Gewerbl. Preuss.*, bd. xvii, pp. 37-42. [1838.]
1032. **Broadhead, G. C.** Geology of North-western Missouri. *Rep. Geol. Surv. Missouri*, 1873, pt. ii, pp. 1-213, 290-402.
1033. ——— Jasper County, Missouri. *Ibid.*, 1873-1874, pp. 77-96.
1034. ——— Occurrence of Bitumen in Missouri. *Trans. Acad. Sci. St. Louis*, vol. iii, pp. 224-226. [1875.]
1035. ——— Bitumen, Asphaltum, Petroleum, Pyroschists, and certain other solid Hydrocarbons. *West. Rev. Sci. Ind.*, vol. 1, pp. 209-224. [1877.]
1036. ——— Bitumen, Asphaltum, Petroleum, etc., Philadelphia International Exhibition, 1876. U. S. Centennial Commission. Reports and Awards. Group 1. 8vo, Philadelphia, 1878.
1037. ——— The Bituminous and Asphalt Rocks of the United States. *Amer. Geol.*, vol. xxxii, pp. 59, 60. [1903.]
1038. ——— Bitumen and Oil Rocks. *Ibid.*, vol. xxxiii, pp. 27-35. [1904.]
1039. **Brock, R. W.** Summary Reports of the Geological Survey of Canada for 1907-1910. [1908-1911.]
1040. ——— Le Canada et ses ressources minérales. *Bull. Soc. Géogr. Québec*, vol. iv, pp. 235-247. [1910.]
1041. **Brock, R. W.**, see **Young, G. A.**
1041. **Brodtmann, —.** Verhinderung der Entzündlichkeit des Benzins. *Pharm. Zeit.*, bd. 1, p. 706. [1905.]
1042. **Bromeis, C.** Ueber den Fichtel, eine neue Art Bergtaig. *Ann. Chem. Pharm.*, bd. xxxvii, pp. 304-306. [1841.]
1043. **Bronn, H. G.** Handbuch einer Geschichte der Natur. 5 Bde. 8vo, Stuttgart, 1841-1849.
1044. **Brooks, A. H.** The Investigation of Alaska's Mineral Wealth. *Trans. Amer. Inst. Min. Eng.*, vol. xxxv, pp. 376-396. [1905.]
1045. ——— Mineral Resources of Alaska. *Bull. U. S. Geol. Surv.*, no. 391, pp. 172-207, pl. xii. [1910.]
1046. ——— The Mining Industry [of Alaska] in 1910. *Ibid.*, no. 480, pp. 21-24. [1911.]
- Bross, W.**, see **Teichmann, H.**
1047. **Brough, B. H.** Outbursts of Gas in Metalliferous Mines. *Trans. N. Engl. Inst. Eng.*, vol. xxxviii, pp. 59-72. [1891.]
1048. ——— The Mining of Non-metallic Minerals. *Cantor Lectures*, vol. vii, 1904.
1049. **Browallius, J.**, see **Spöcing, H. D.**
1049. **Brown, A. F.** The Oilfields of Russian Sakhalin. *Mining Journ.*, vol. xciii, pp. 380-382. [1911.]
1050. **Brown, H. C.** Report on the Mineral Resources of Cuba in 1901. *Baltimore*, 1902. Vol. v, pt. 2, of Gen. L. Wood's Civil Report on Cuba.
1051. **Brown, H. Y. L.** Record of the Mines of South Australia. 8vo, Adelaide, 1890.
1052. ——— South Australia, Northern Territory (N.W. District) Reports (Geological and General) resulting from the Explorations made by the Government Geologist and Staff during 1905. 8vo, Adelaide, 1906.
1053. **Brown, J. C.** Recent Accounts of the Mud-Volcanoes of the Arakan Coast. *Rec. Geol. Surv. Ind.*, vol. xxxvii, pp. 264-279, pl. xxv. [1909.]
1054. **Brown, J. F. K.** The Working of South African Oil Shales. *S. Afric. Mining Journ.*, vol. ix, pt. 1, pp. 352, 396. [1911.]
1055. **Brown, R. T.** Report of Fountain County. *Ann. Rep. Geol. Surv. Indiana*, vol. xi, pp. 89-125. [1882.]
1056. **Browne, T. B.** Some Points affecting the Design of Petrol Motor Vans, with some Details relating to the Running Costs. *Proc. Inst. Automob. Eng.*, n.s., vol. iv, pp. 167-268. [1909.]
1057. **Brückner, —.** Ueber einige eigenthümliche, wachsartige Braunkohlen. *Journ. prakt. Chem.*, bd. lvii, pp. 1-21. [1852.]
1058. **Brühl, J. W.** Ueber die Bestimmung des specifischen Gewichts zähflüssiger Substanzen. *Ber. deutsch. chem. Ges.*, bd. xxiv, pp. 182, 183, 2455-2457. [1891.]
1059. **Brüsch, —.** Die Beleuchtungsarten der Gegenwart. [1909.]
1060. **Brugge, F.** [Methods of Working Petroleum Wells in Galicia.] *Tiefbohrwesen*, 1908, h. 21.
1061. **Brunatelli, L. V.** Memoria sulla chimica costituzione del gas olofacente e de' gas flogogeni carburati cavati da sostanze vegetabili e minerali, e dalle acque paludose; contenente un nuovo apparecchio per esaminarli. *Giorn. Fis. Chim. St. Nat.*, vol. vii, pp. 249-257. [1814.]
1062. **Bruhn, B.** Ueber die Constitution und die Entstehung der Naphthene. *Chem.-Zeit.*, bd. xxii, pp. 900-902. [1898.]
1063. **Brunell, H. P. H.** Report on the Mining and Mineral Statistics of Canada for the year 1888. *Ann. Rep. Geol. Surv. Canada*, u.s., vol. iv, report S, pp. 93. [1890.]
1064. ——— Report on Natural Gas and Petroleum in Ontario prior to 1891. *Ibid.*, n.s., vol. v, report Q, pp. 94, 4 pls. [1893.]
1065. ——— Petroleum. *Ibid.*, report SS, pp. 120-133, pl. ix. [1893.]
1066. ——— On the Geology of Natural Gas and Petroleum in South-western Ontario. *Bull. Geol. Soc. Amer.*, vol. iv, pp. 225-240. [1893.]
1067. ——— Notes on the Occurrence of Petroleum in Gaspé, Quebec. *Ibid.*, pp. 211-244. [1893.]
1068. **Brunell, H. P. H.**, see **Inglall, E. D.**
1068. **Brun, A.** L'Hydrogène des Volcans. *Bull. Soc. belg. Géol.*, t. xvii, Proc.-verb., pp. 554, 555. [1904.]
1069. ——— Quelques Recherches sur le Volcanisme; avec Analyse des Gaz de l'Obsidienne de A. Jaquero. *Arch. Sci. Phys. Nat.*, sér. 4, t. xix, pp. 439-450, 589-606, pl. vii. [1905.]
1070. **Brunet, —.** [ . . . Artificial Bitumen; Suggested Origin of Petroleum, etc. ] *Bull. Soc. Géol. France*, t. ix, p. 252. [1838.]
1071. **Brunet, —.** [Carburetted Hydrogen at Bex, Switzerland.] *Compt. Rend. Soc. Ind. Min.*, 1882, p. 129.
1072. **Brunner, R.** Die Fabrikation der Schmiermittel, der Schuhwische und Lederschmiere. 8vo, Vienna, Budapest, and Leipzig, ed. ii, 1880.
1073. **Brunton, R. H.** The Production of Paraffin and Paraffin Oils. *Proc. Inst. Civ. Eng.*, vol. lxxvi, pp. 180-237, pls. vi, vii. [1881.]
1074. **Brusov, S.** [Rapidity of Formation of Olefines.] *Jurn. Russk. Fiz. Khim. Obsch.*, t. xxvii, otd. 1, pp. 7-28. [1900.]
1075. **Bruyn, C. A. L. de.**, see **Lobry de Bruyn, C. A.**
1075. **Bryant, A. P.**, see **Day, W. C.**
1075. **Buch, L. von.** [Catalogue of a Collection of Rocks.] In his "Gesammelten Schriften," 1803.
1076. **Buchenauf, F.** Ueber Petroleum *Berlin*, 1872.
1077. **Buchner, G.** Ueber das Erdöl von Tegernsee. *Chem.-Zeit.*, bd. viii, p. 911. [1884.]
1078. ——— Ueber das Wachs der Bacillariaceen und seinen Zusammenhang mit dem Erdöl. *Bayer. Ind. Gewerbl.*, bd. xxxii, p. 86. [1900.]
1079. ——— Erdölverwendung in Kalifornien. *Ibid.*, bd. xli, pp. 160, 161. [1909.]
1080. **Buchner, J. A.** Versuch über das Bergöl von Tegernsee. *Rep. Pharm.*, bd. ix, pp. 290-303. [1820.]
1081. **Buchner, M.** Ueber das sogenannten Kaiseröl. *Polyt. Journ.*, bd. ccxxvii, pp. 381, 382. [1878.]
1082. ——— Ueber die Verfälschung des Bienenwachses [wegen Ceresin]. *Ibid.*, bd. ccxxxi, pp. 272, 273. [1879.]
1083. **Buchner, O.** Die Mineralöle, insbesondere Photogen, Solaröl und Petroleum. *Weimar*, 1864.
1084. ——— Wallachisches Petroleum. *Polyt. Journ.*, bd. clxxii, pp. 392-394. [1864.]
1085. **Bucholz, C. F.** Beschreibung und Analyse eines bei Halle gefundenen Erdharzes welches höchstwahrscheinlich mit dem von Hattchett untersuchten und Retinasphalt genannt eierlei ist. *Journ. Chem. Phys.*, bd. 1, pp. 290-299. [1811.]

1086. **Bucholz, C. F.** Analyse d'un bitume particulier trouvé en Saxe. *Ann. Chim. Phys.*, t. lxxiii, pp. 323-328. [1812.]
1087. **Buck, D.** Early History of Pennsylvania. 1876.
1088. **Buck, D. M.**, see **Mabery, C. F.**
1088. **Buckland, J.** Geological Account of a Series of Animal and Vegetable Remains, and of Rocks, collected by J. Crawford, Esq., on a voyage to the Irawadi to Ava in 1826, 1827. *Trans. Geol. Soc.*, ser. 2, vol. ii, pp. 377-392. [1828.]
1089. **Buerk, —.** Petroleum as a Fuel at Sea. *Iron Age*, 1878, no. 24, p. 2.
1090. **Buff, H.**, and **A. W. Hoffmann.** Zerlegung gasförmiger Verbindungen durch electrisches Glühen. *Ann. Chem. Pharm.*, bd. cxlii, pp. 129-150. [1860.]
1091. **Buffon, G. L. de**, and **L. J. M. Daubenton.** Histoire Naturelle des Minéraux. In P. N. générale et particulière. 4to, Paris, 1749-182, and separately 5 Tt. 12mo, Paris, 1801.
1092. **Bulgakov, A. A.** [Petroleum.] *Gorn. Journ.*, 1887, t. 3, pp. 59-109.
1093. ——— [Mineral Wealth of Petrovsk and Grozni.] *Trudi Imp. Russk. Techn. Obsch.*, 1893, Nov.-Dec., pp. 19-32; 1894, Jan.-Feb., pp. 1-42.
1094. ——— [The Geras Oil-district (Elisabetpol, Transcaucasia).] *Gorn. Journ.*, 1894, t. 3, pp. 259-262.
1095. **Bult, H. J.** The most recent Refinery Improvements. *Petroleum*, vol. ii, pp. 344, 428. [1901.]
1096. ——— The Flash Point of Petroleum Mixtures. *Petroleum World*, vol. v, pp. 336, 337. [1907.]
1097. **Bunning, C. Z.**, and **J. K. Guthrie.** Description of an Instrument for ascertaining the Inclination, from the Perpendicular, of Boreholes, and the Direction of such Inclination. *Trans. N. Engl. Inst. Eng.*, vol. xxix, pp. 61-70. [1880.]
1098. **Bunsen, R.** Recherches sur la Formation des Roches volcaniques en Islande. *Ann. Chim. Phys.*, sér. 3, t. xxxviii, pp. 215-300. [1853.]
1099. **Bunsen, R. W.** Ueber Erdölquellen in der Umgegend von Peine und Celle. *Jahresb. Ver. Naturk. Cassel*, bd. iii, pp. 12, 13. [1839.]
1100. **Bante, H.** Ueber Carburatation des Leuchtgases. *Journ. Gasbeleucht.*, bd. xxvii, pp. 442-449. [1893.]
1101. **Burat, A.** Traité du Gisement et de la Recherche des Minéraux Utiles. 8vo, Paris, 1870
1102. **Burckhardt, J. L.** Travels in Syria and the Holy Land. 4to, London, 1822.
1103. **Burenin, S.** [Petroleum and the Methods of its Manufacture from a Sanitary Point of View.] *St. Petersburg*, 1888.
1104. **Burg, O.** Ueber Braunkohlen-Theer. *Ber. deutsch. chem. Ges.*, bd. ix, pp. 1207-1209. [1876.]
1105. ——— Ueber einen neuen Kohlenwasserstoff aus dem Braunkohlentheer, das Picen. *Ber. deutsch. chem. Ges.*, bd. xiii, pp. 1834-1837. [1880.]
1106. **Burg, O.**, see **Liebermann, C. T.**
1106. **Burgess, M. J.**, and **R. V. Wheeler.** The Lower Limit of Inflammation of the Paraffin Hydrocarbons with Air. *Journ. Chem. Soc.*, vol. xcix, pp. 2013-2030. [1911.]
1107. **Burggraf, A.** Das Verhalten der Förderselle beim Erdölschöpfungsbetriebe. *Petroleum Zeitschr.*, bd. vi, pp. 2175-2177. [1911.]
1108. **Burgmann, A.** Petroleum und Erdwachs. Darstellung der Gewinnung von Erdöl und Erdwachs (Ceresin), deren Verarbeitung auf Leuchtöle und Paraffin . . . . 8vo, Vienna, 1880.
1109. **Burk, W. E.** Asphalt Rock in Kentucky. *Eng. Min. Journ.*, vol. lxxv, pp. 969, 970. [1902.]
1110. **Burkart, —.** Das Petroleum und seine Produktion in Nordamerika. *Berg-Hütt. Zeit.*, bd. xxix, pp. 373-376. [1870.]
1111. **Burkhardt, —.** [Report for the year 1886 on the Trade of] Batoum. *Dipl. Cons. Rep.*, ann. ser., no. 115, pp. 20-25. [1887.]
1112. **Burkhardt, H. W.** Oil Situation from a Gas Man's View-point. *Progress. Age*, vol. xxviii, pp. 960-962. [1910.]
1113. **Burmeister, A. A.** [Operations for closing and controlling the Spouter in Group XIII.] *Zap. Kark. Otd. Imp. Russk. Techn. Obsch.*, t. viii, pp. 228-233. [1876.]
1114. **Burnes, A.** Peshawar Coal. *Journ. As. Soc. Beng.*, vol. ii, p. 267. [1833.]
1115. **Burnley, J.** Across the Oil-Fields. Chapter X of "Summits of Success." London, 1901.
1116. **Burns, W.** Illuminating and Heating Gas. A Manual of the Manufacture of Gas from Tar, Oil, and other Liquid Hydrocarbons, and extracting Oil from Sewage Sludge. 8vo, London, 1887.
1117. **Burns, W. H.** Bituminous Macadam Pavements. *Journ. Assoc. Eng. Soc.*, vol. xxviii, pp. 297-302. [1902.]
1118. **Burr, G. A.** Petroleum in Texas and Mexico. *Eng. Min. Journ.*, vol. lxxi, pp. 687, 688. [1901.]
1119. **Burrell, G. A.** Natural Gas from the Petroleum Fields of Southern California. *Bull. Bureau Mines, U.S.A.*, no. 19, pp. 47-56. [1911.]
1120. **Burrell, W. P.** Report for the years 1886-1889 on the Trade of Port Said. *Dipl. Cons. Rep.*, ann. ser., nos. 142, 294, 485, 634. [1887-1890.]
1121. **Burroughs, W. G.** The Petroleum Fields of the United States. *Eng. Min. Journ.*, vol. lxxxix, pp. 921-924. [1910.]
1122. ——— Formation of Petroleum Accumulations. *Cassier's Mag.*, vol. xi, pp. 597-605. [1911.]
1123. **Burton, F. W.** Some Future Developments of Heat Engines. *Journ. West Scotland. Iron and Steel Inst.*, vol. xiii, pp. 98-110, 139-146, 151-166. [1906.]
1124. **Burton, E. F.** A Radioactive Gas from Crude Petroleum. *Phil. Mag.*, ser. 6, vol. viii, pp. 498-508. [1904.]
1125. **Burton, E. F.**, and **V. L. Cameron.** On Stone Implements from the Gold Coast, West Africa. *Journ. Anthropol. Inst.*, vol. xii, pp. 449-453. [1883.]
1126. **Burton, W. M.** A Method for the Detection and Estimation of Petroleum in Oil of Turpentine. *Amer. Chem. Journ.*, vol. xii, pp. 102-104. [1890.]
- Burwell, A. W.**, see **Worstall, R. A.**
- Buryanads, J.**, see **Ostromislenski, J.**
- Buschiazzo, J. A.**, see **Nystromer, C.**
1127. **Bushe, R. G.** Trinidad and Tobago. Reports on the Blue Book for 1907, 1908, and 1910-1911. *Colonial Rep.*, ann. ser., nos. 587, 699. [1908, 1911.]
- Bushong, F. W.**, see **Haworth, E.**
1128. **Busley, C.** Die Verwendung flüssiger Helzstoffe für Schiffsessel. *Zeitschr. Ver. deutsch. Ing.*, bd. xxxi, pp. 989-995, 1013-1019, 1037-1044, 1069-1071, 1089-1095, 1109-1116. [1887.]
1129. **Bussenius, —**, and — **Eisenstück.** Ueber einige Derivate des Petrols, eines im Steiñöl vorkommenden Kohlenwasserstoffes. *Ann. Chem. Pharm.*, bd. cxlii, pp. 151-169. [1860.]
1130. **Busson-Dumaurier, —**, and — **Rouen.** Sur l'éclairage par les huiles essentielles de houille, de schiste, etc. *Compt. Rend.*, t. xvi, pp. 1164, 1165. [1843.]
1131. **Bustamante, M.** Informe sobre los criaderos carboníferos de las Huastecas. *An. Min. Pom. Repub. Mexico*, t. vii, pp. 533-547. [1832.]
1132. ——— Ligero estudio sobre los pozos de "El Ébano," explotados por la Mexican Petroleum Co. *Bol. Soc. Geol. Mex.*, t. ii, pp. 111-131, pl. [1906.]
- Butler, —**, see **Wright, —**
1133. **Butler, E.** Carburettors, Vaporisers, and Distributing Valves used in Internal Combustion Engines. 8vo, London, 1909.
1134. ——— Practical Management of Gas and Oil Engines. *Gas and Oil Power*, vol. iv, pp. 203, 204, 234, 235. [1909.]
1135. **Butlerow, A. I.** Ueber einige Kohlenwasserstoffe der Reihe CaH<sub>2n</sub>. *Ann. Chem. Pharm.*, bd. cxlv, pp. 271-283. [1868.]
1136. ——— Sur la structure chimique de quelques hydrocarbures non-saturés. *Mém. Acad. Imp. Sci. St. Pétersb.*, sér. 7, t. xv, no. 7. [1870.]
1137. ——— [Illuminating Gas.] *St. Petersburg*, 1875.

1138. **Butlerow, A. I.** Condensation des hydrocarbures de la série éthylique. *Mém. Acad. Imp. Sci. St. Pétersb. sér. 7, t. xxiii, no. 4; t. xxvii, no. 3.* [1877, 1880.]
1139. **Butlerow, A. I., and — Zinina.** [Problem of the Spontaneous Ignition of Petroleum.] *Morsk. Sborn., 1871, no. 8, pp. 21-23.*
- Butlerow, A. I., see Goriainow, W.**
1140. **Butterfield, W. J. A.** The Chemistry of Gas Manufacture. A Practical Treatise on the Production, Purification, and Testing of Illuminating and Fuel Gas, and on the By-products of Gas Manufacture. 8vo, London, 1896.
1141. **Butts, C.** Rural Valley, Pa. Fo. 125, *U. S. Geol. Surv., 1905.*
1142. ——— Economic Geology of the Kittanning and Rural Valley Quadrangles, Pennsylvania. *Bull. U. S. Geol. Surv., no. 279.* Pp. 198; 11 pls. [1906.]
1143. ——— Warren, Pa. Fo. 172, *U. S. Geol. Surv., 1910.*
1144. **Butts, C., and F. Leverett.** Kittanning, Pa. Fo. 115, *U. S. Geol. Surv., 1904.*
1145. **Byasson, H.** Sur l'origine du Pétrole. *Compt. Rend., t. lxxiii, pp. 609-611.* [1871.]
1146. ——— Mémoire sur l'origine du Pétrole. Paris, 1876.
- Byerley, J. H., see Mabery, C. F.**
1147. **Byrne, P.** Oil and Gas Prospects in the State of Alabama. *Proc. Eng. Assoc. South, vol. xxi, pp. 167-177.* [1910.]
1148. **Byström, A.** [The Use of Liquid Fuel in Open Hearth Furnaces in Russia.] *Bihang Jernkont. Ann., 1901, pp. 301-309.*
1149. ——— Der russische Martinföfen mit Erdölfeuerung. *Oesterr. Zeitschr. Berg.-Hütt., bd. I, pp. 34-36.* [1902.]
1150. **Byxbee, J. F.** The Use of Asphaltic Flux for Coating Macadam Roads at Palo Alto, Cal. *Engineering News, vol. lxi, p. 519.* [1909.]
1151. **C——, A.** Le Pétrole dans la Nouvelle-Zélande. *Journ. Pétrole, t. x, pp. 145, 146.* [1910.]
1152. **Cabot, S., jun.** Action of Sulphur at High Temperatures upon Normal Paraffins. *Amer. Chem., vol. vii, p. 20.* [1876.]
1153. ——— Conversion of the Normal Paraffins into the Benzole Series. *Chem. News, vol. xxxvi, p. 140.* [1877.]
1154. **Cabrera, R.** Mineral Resources of Cuba. *Journ. Franklin Inst., vol. cxlvi, pp. 26-41.* [1898.]
1155. **Cacciarioli, G. B.** Petrolé e bitumi di Valle Latina. *Riv. Ital. Sci. Nat. Stena, anno. ix, nos. 6, 7, 10-12.* [1889.]
1156. ——— Sopra un affioramento di schisto bituminoso a Santopadre in provincia di Caserta. *Boll. R. Com. Geol. Ital., vol. xxi, pp. 436-441.* [1890.]
1157. ——— Geologia Arpinate. *Boll. Soc. Geol. Ital., vol. xi, pp. 293-333.* [1892.]
1158. **Cadell, H. M.** The Oil Shales of the Scottish Carboniferous System. *Journ. Geol., vol. ii, pp. 243-249.* [1894.]
1159. ——— Petroleum and Natural Gas; their Geological History and Production. *Trans. Edinb. Geol. Soc., vol. vii, p. 51.* [1894.]
1160. ——— Geology of the Oil-shale Fields of the Lothians. *Ibid., vol. vii, pp. 116-162.* [1901.]
1161. ——— The Oil-shale Fields of the Lothians. *Trans. Inst. Min. Eng., vol. xxii, pp. 314-371, pls. viii, ix.* [1902.]
1162. **Cadell, H. M., and J. S. Flett.** On an Ash Neck in the Broxburn Shale Workings at Phillipstoun. *Trans. Edinb. Geol. Soc., vol. vii, pp. 477-481.* [1899.]
1163. **Cadell, H. M., J. S. G. Wilson, W. Caldwell, and D. R. Steuart.** The Oil-shales of the Lothians. *Mém. Geol. Surv. Scotl.* Pp. viii, 194; 3 pls. [1906.]
1164. **Cadman, J.** Report of the Inspector of Mines, Trinidad. *Council Paper, 1906, no. 130.*
1165. ——— Mineral Resources of Trinidad. *Trans. Inst. Min. Eng., vol. xxxv, pp. 453-480; vol. xxxvi, pp. 589, 590.* [1908, 1909.]
1166. **Cady, H. P., and D. F. McFarland.** The Occurrence of Helium in Natural Gas, and the Composition of Natural Gas. *Journ. Amer. Chem. Soc., vol. xxix, pp. 1523-1536.* [1907.]
1167. ——— Neon and Argon in Natural Gas. *Trans. Kansas Ac. Sci., vol. xxi, pp. 64, 65.* [1908.]
- Cady, H. P., see Haworth, E.**
1168. **Cagnat, —.** Ozokerit. *Bull. Soc. Chim. Paris, sér. 2, t. xxix, p. 95.* [1878.]
1169. **Cahours, A., and E. Demarçay.** Sur les hydrocarbures qui prennent naissance dans la distillation des acides gras bruts en présence de la vapeur d'eau surchauffée. *Compt. Rend., t. lxxx, pp. 1568-1572; t. lxxxix, pp. 331-336; t. xc, pp. 156-159; t. xciv, pp. 610-613.* [1875, 1879, 1880, 1882.]
- Cahours, A., see Pelouze, J.**
1170. **Caillard, R. du.** [Bitumen of the Chatt-el-Arab Basin.] *Compt. Rend. Soc. Geogr. Paris, 1885, pp. 120, 121.*
1171. ——— [Note on Petroleum in Egypt.] *Ibid., 1886, p. 205.*
1172. ——— [Petroleum in Syria in the Fifteenth Century B.C.] *Ibid., 1887, p. 292.*
1173. **Cairnes, D. D.** Moose Mountain District of Southern Alberta. *Publ. Geol. Surv. Canada, no. 968.* Pp. 86, 3 pls. 2 maps. [1907.]
1174. **Cairns, J. F.** Petrol Tractors. *Cassier's Mag., vol. xxxii, pp. 84-92.* [1907.]
1175. **Calderon, D. S.** Los Minerales de España. 8vo, Madrid, 1910.
- Calderon, D. S., see Tenne, C. T. A.**
1176. **Caldwell, J.** Electric Power-Station, Winding-Gear and Pumping-Plant of the Tarbrax Oil Company, Limited. *Trans. Inst. Min. Eng., vol. xxxi, pp. 221-230; vol. xxxii, pp. 102.* [1906, 1907.]
1177. **Caldwell, J. K.** Coal-dust and Petroleum Furnace. *Sci. Amer. Suppl., vol. I, p. 125.* [1876.]
1178. **Caldwell, W.** The Working of Oil-shale at Pumpherson. *Trans. Inst. Min. Eng., vol. xxxvi, pp. 581-589.* [1909.]
- Caldwell, W., see Cadell, H. M.**
1179. **Calogari, M., and G. Canestrini.** Storia della Salsa di sopra presso Sassuolo, della sorgente della Salvarola e dei pozzi oleiferi di Montegibbio. *Ann. Soc. Nat. Modena, vol. ii, pp. 147-168.* [1867.]
1180. **Call, —.** *Monthly Rev. Iowa Weather Service, Nov. 1892.*
1181. **Callendar, H. L.** The Effect of Size on the Thermal Efficiency of Motors. *Proc. Inst. Automob. Eng., n.s., vol. I, pp. 223-232.* [1907.]
1182. **Callier, C.** Sur le bassin de la mer Morte. *Journ. Savants, 1836, pp. 46-48.*
1183. **Calmel, A.** Le Transport du Pétrole. *Journ. Pét., t. i, pp. 3-5, 21-23, 40, 41, 55, 76, 71-73.* [1901.]
1184. ——— Le Pétrole en Algérie. *Ibid., t. ii, pp. 73-75.* [1902.]
1185. ——— Boryslaw et l'avenir de la Galicie. *Ibid., t. iv, pp. 121, 123.* [1904.]
1186. ——— L'Algérie pétrolière. *Ibid., pp. 145, 147.* [1904.]
1187. ——— Le Pétrole en Algérie. Une heureuse Campagne. *Ibid., t. v, p. 377.* [1905.]
1188. ——— Les sondes portatives. *Ibid., t. vi, pp. 8, 9.* [1906.]
1189. ——— Le Commerce du Pétrole en 1905 en France. *Ibid., pp. 71-73.* [1906.]
1190. ——— L'initiative et les capitaux français en Roumanie. *Ibid., pp. 101-105.* [1906.]
1191. ——— Étude des propriétés physiques des huiles brutes. *Ibid., t. ix, pp. 242-245, 258-261; t. x, pp. 2-4, 21, 37, 38, 51-53.* [1909, 1910.]
1192. **Calmelet, F. T.** Description de la mine de lignite de Lobsenz, arrondissement de Wissenbourg, département du Bas Rhin. *Journ. Mines, t. xxxvii, pp. 369-378.* [1815.]
1193. **Calvet, —, — Desvignes, — Guibert, A. Guiselin, and E. Tassily.** Unification des Méthodes d'Essai des Pétales. *Compt. Rend. Congr. internat. Pétrole, sess. 3, t. ii, pp. 805-807.* [1910.]

1194. **Calvin, S.** Ninth Annual Report of the State Geologist [of Iowa]. *Ann. Rep. Iowa Geol. Survey*, vol. xi, pp. 9-30, pls. 1-4ii. [1901.]
1195. ——— Tenth Annual Report of the State Geologist [of Iowa]. *Ibid.*, vol. xii, pp. 11-27, pl. 1. [1902.]
1196. **Cambresy.** —. Étude sur les terrains pétrolifères de Kovacs. *Paris*, 1884.
1197. **Camden, W.** Britannia, sive Florentissimum Regnum Angliæ, Scotiæ, Hiberniæ, et Insularum adiacentium ex intima antiquitate, Chorographica Descriptio. *Svo, London*, 1586.
1198. **Cameraux, E.** L'Industrie des Hydrocarbures en Italie. *Svo, Rome*, 1907.
1199. ——— Appunti sull'industria petrolifera della Romania. *Rass. Min.*, vol. xxviii, pp. 85-89, 102-106. [1903.]
1200. ——— [Description of Boring for Petroleum in Italy.] *Vulkan*, vol. viii, pp. 28, 29, 33-36, 41-43, 50, 51, 61, 62, 67, 68. [1905.]
1201. **Cameraux, E.** and **B. Galdi.** I Giacimenti Petroliiferi dell' Emilia. *Mem. Cart. Geol. Ital.*, vol. xiv, 1911.
1202. **Cameron, James.** Oils and Varnishes. *London*, 1868.
1203. ——— Soaps and Candles. *Svo, London*, 1888.
1204. **Cameron, John M.** The Bituminous Deposits of the Camamu Basin, Province of Bahia in the Brazilian Empire. *Svo, London*, 1884.
- Cameron, V. L.**, see **Burton, R. F.**
1205. **Cameron, W. E.** The Coal-beds of Waterpark Creek, near Port Clinton (Queensland). *Brisbane*, 1902.
1206. ——— The Fire at the Oil-Bore at Roma, Queensland. *New Zeal. Mines Rec.*, vol. xii, pp. 232, 233. [1908.]
- Camp, J. G.**, see **Ureu, S.**
1207. **Campbell, D.** Economic History of Paraffine. *Journ. Soc. Arts*, vol. ix, pp. 393-395. [1861.]
1208. **Campbell, M. R.** Standing Stone (Tenn.). *Fo. 53, U.S. Geol. Surv.*, 1899.
1209. ——— Charleston (W. Va.). *Fo. 72, Id.*, 1901.
1210. ——— Masetown — Uniontown (Penn.). *Fo. 82, Id.*, 1902.
1211. ——— Brownsville—Connellsville (Penn.). *Fo. 94, Id.*, 1903.
1212. ——— Geographic Development of Northern Pennsylvania and Southern New York. *Bull. Geol. Soc. Amer.*, vol. xiv, pp. 277-296. [1903.]
1213. ——— Recent work in the bituminous Coalfield of Pennsylvania. *Bull. U.S. Geol. Surv.*, no. 213, pp. 270-275. [1903.]
1214. **Campbell, W.** The Island of Formosa, its past and future. *Scott. Geogr. Mag.*, vol. xii, pp. 385-399. Map. [1896.]
1215. **Campos, G.** Reconhecimento geologico e estudo das substancias bituminosas na bacia do rio Marahu, Estado de Bahia. [1902.]
1216. **Camusat, J.** Les hypothèses modernes sur la genèse du pétrole, suivies de considérations géologiques sur la formation du boghead Autonois. *Bull. Soc. Hist. Nat. Autun*, t. xii, pp. 72-100. [1899.]
1217. **Canavari, M.** Gli schisti a fucoidi, e gli schisti bituminosi che spesso li accompagnano nell' Appennino centrale. Una Radiolite del Suavincio. *Proc. verb. Soc. Tesc. Sci. Nat.*, vol. iii, pp. 6, 7. [1881.]
- Canestrini, G.**, see **Calogari, M.**
1218. **Caneto.** —. [Dead Sea.] *Arch. Philos. Chrét.*, t. xii, p. 422. [1836.]
1219. **Cantemir, D.** Description de la Moldavie. [1716.]
1220. **Canton, M.** Das mechanische Äquivalent der Verbrennung und Konstruktion eines rationellen Verbrennungsmotors. *Physik. Zeitschr.*, bd. vi, pp. 805, 806. [1905.]
1221. **Capacci, C.** Etude sur les Gisements de Pétrole Bitume et Asphalt du Bassin du Liri dans l'Italie meridionale (Frosinone-Casserte). *Compt. Rend. Congr. internat. Pétrole*, sess. 3, t. ii, pp. 281-340. [1910.]
1222. **Capellini, G. G.** Report on the Petroleum Districts in Wallachia, belonging to the Wallachian Petroleum Co., Ltd. *London*, 1864.
1223. ——— Relazione sul petrolio di Tocco e sul bitume di Letto Manopello. *Svo, Turin*, 1866.
1224. ——— Giacimenti Petroliiferi di Valachia e loro rapporti coi terreni terziari dell' Italia. *Mem. Acc. Sci. Bologna*, sér. 2, vol. vii, pp. 323-358. [1868.]
1225. ——— Sui terreni terziari di una parte del versante settentrionale dell' Appennino. Appunti per la geologia della provincia di Bologna. *Ibid.*, sér. 3, t. vi, pp. 587-624, pl. [1876.]
1226. **Capitaine, E.** Petroleum-Kraftmaschine. *Zeitschr. Ver. deutsch. Ing.*, bd. xiii, pp. 1458-1462, pl. xix. [1899.]
1227. ——— Zur Frage der Verwendbarkeit schwer brennbarer Oele in Verbrennungskraftmaschinen. *Ibid.*, bd. ii, p. 1109-1111. [1907.]
- Capron, H.**, see **Blake, W. P.**, and **Lyman, B. S.**
1228. **Capstick, J. W.** On the Ratios of the Specific Heats of the Paraffin and their Monohalogen Derivatives. *Proc. Roy. Soc.*, vol. liv, pp. 101-104. [1893.]
1229. **Caracristi, C. F. Z.** Coal and Petroleum in Colombia. *Bureau of the American Republics, Spec. Bull.*, pp. 23. *Svo, Washington*, 1893.
1230. ——— Business Opportunities in Colombia. *Eng. Mag.*, vol. ix, pp. 883-907. [1895.]
1231. ——— A New Field for the Development of Coal and Petroleum [Colombia]. *Iron and Coal Trades Review*, vol. lvii, pp. 349-351. [1898.]
1232. ——— The World's Production of Petroleum. *Min. Ind.*, vol. viii, pp. 454-466. [1900.]
1233. **Caralp.** —. Le graphite et les combustibles minéraux de la région pyrénéenne. *Bull. Soc. Hist. Nat. Toulouse*, ann. 23, pp. 141-166. [1889.]
1234. **Cardan, J.** De Subtilitate. *Svo, Paris*, 1551.
1235. **Cardone, L.** Di Salso e delle sue Saline. *Politecnico*, vol. xi, pp. 237-240. [1861.]
1236. **Cario, C.** Petroleum zum Kesselreinigen. *Mith. Praxis Dampfkesel - Dampfmasch. - Betriebes*, bd. xvi, p. 317. [1893.]
1237. **Carles, M. P.** Les Huiles de Graissage pour Automobiles et leurs Fraudes. *Bull. Soc. Chim. Paris*, sér. 4, t. vii, pp. 589-591. [1910.]
1238. **Carll, J. F.** Report of Progress I2, Oil-well Records and Levels. *2nd Geol. Surv. Penns.* *Svo, Harrisburg*, 1877.
1239. ——— The Geology of the Oil Regions of Warren, Venango, Clarion and Butler Counties, including Surveys of the Garland and Panama Conglomerates in Warren and Crawford, and in Chautauqua County, N.Y., descriptions of Oil-well rig and tools, and a discussion of the Preglacial and Postglacial drainage of the Lake Erie country. *Ibid.*, I3. Pp. 482, 23 pls.; Atlas, 22 pls. *Svo, Harrisburg*, 1880.
1240. ——— Geological Report on Warren County and the neighbouring Oil Regions, with additional Oil-well Records. *Ibid.*, I4. Pp. 440. *Svo, Harrisburg*, 1883.
1241. ——— Preliminary Report on Oil and Gas. *Ann. Rep. Geol. Surv. Penns.* for 1885, pp. 1-81, map.
1242. ——— The Oil and Gas Region. *Ibid.*, 1886, pp. 575-786, 5 pls. [1887.]
1243. ——— Natural Gas in Pennsylvania. *Amer. Manufacturer, Nat. Gas Suppl.*, no. 2. [1886.] Republished in *Min. Res. U.S.*, 1887, pp. 467-474. [1888.]
1244. ——— Seventh Report on the Oil and Gas fields of Western Pennsylvania. *2nd Geol. Surv. Penns.*, I5. *Svo, Harrisburg*, 1890.
1245. **Carll, John F., F. A. Randall,** and **J. P. Lesley.** Report of Progress in the Venango County District by J. F. C., with observations on the Geology around Warren by F. A. R., and note on the Comparative Geology of North-Eastern Ohio and North-Western Pennsylvania and Western New York by J. P. L. *Ibid.*, I. *Svo, Harrisburg*, 1875.
1246. **Carmichael, W. V.** Liquid Fuel in Ocean Steamers. *Papers Shipmasters' Soc.*, no. 9. Pp. 24. [1891.]

1247. **Carne, J. E.** On certain Coal and Shale Lands in the Capertee Valley District, N.S. Wales. *Rec. Geol. Surv. N.S. Wales*, vol. iv, p. 39. [1894.]
1248. ——— Progress Report for 1900, and Mineralogical and Geological Notes. *Ann. Rep. Mines, N.S. Wales*, 1900, pp. 182-185. [1901.]
1249. ——— The Kerosene Shale Deposits of New South Wales. *Mem. Geol. Surv. N.S. Wales*, Geol. no. iii, pp. xiii, 333, 26 pls., 11 maps and sections. [1903.]
1250. ——— Geology and Mineral Resources of the Western Coalfield, N.S.W. *Ibid.*, Geol. no. vi. Pp. 264, 38 pls., 8 maps. [1908.]
1251. **Carnegie, A.** On Natural Gas Fuel and its Application to Manufacturing Purposes. *Journ. Iron Steel Inst.*, 1885, vol. i, pp. 168-185.
1252. ——— The Natural Oil and Gas Wells of Western Pennsylvania. *Macmillan's Mag.*, 1885, pp. 208-214.
1253. **Carney, C. T.** Paraffine; its Substitution for Wax in Cerates. *Amer. Journ. Pharm.*, ser. 3, vol. ix, p. 72. [1860.]
1254. **Carpenter, R. C.** The Effect of Oil on Cement Mortar. *Proc. Amer. Soc. Test. Mat.*, vol. vii, pp. 398-400. [1907.]
1255. **Carpenter, R. C., and H. Diederichs.** Internal Combustion Engines. 8vo, London, 1908.
1256. **Carpenter, W. L.** A Treatise on the Manufacture of Soap and Candles, Lubricants and Glycerine. 8vo, London, 1885.
1257. **Carpenter, W. M.** Miscellaneous Notices in Opelousas-Attakapu, etc. *Amer. Journ.* (ser. 1), vol. xxxv, pp. 344-346. [1839.]
1258. ——— Account of the Bituminization of Wood in the Human Era. *Ibid.*, vol. xxxvi, pp. 118-124. [1839.]
1259. **Carpentier, E.** Recherche de la paraffine dans l'huile d'olive. *Bull. Assoc. Belge Chim.*, t. ix, pp. 74-78. [1895.]
1260. **Carpi, P., and G. Ponzì.** Sull' asfalto di Veroli. *Atti Acc. pontif. N. Linc.*, t. v, pp. 535, 536. [1882.]
1261. **Carquillar, A.** Hymne au pétrole, dédié aux républicains présents et à venir. 12mo, Paris, 1873.
1262. **Carrara, J.** [Asphalt at Dolaz-medio, Spalato, Dalmatia.] *Jahrb. k.-k. geol. Reichs.*, bd. i, p. 749. [1850.]
1263. **Carrington, W. T. H.** The Reception and Storage of Refined Petroleum in Bulk. *Proc. Inst. Civ. Eng.*, vol. cv, pp. 108-146, pl. iii. [1891.]
1264. **Carter, H. J.** Report on Geological Specimens from the Persian Gulf, collected by Lieut. C. G. Constable. *Journ. As. Soc. Bengal*, vol. xxviii, pp. 41-48; vol. xxix, pp. 359-365. [1859, 1860.]
1265. **Carter, O. C. S.** Drilling for Oil and Natural Gas in the Vicinity of Philadelphia. *Journ. Franklin Inst.*, vol. cxxviii, pp. 230-236. [1894.]
1266. **Cartwright, F. L.** Petroleum. *Trans. Clifton Coll. Soc. Soc.*, vol. ii, pp. 103-105. [1875.]
1267. **Case, T. S.** The Wyandotte (Kansas) Gas Well. *West. Rev. Sci. Ind.*, vol. i, pp. 321-324. [1877.]
1268. **Cassard, A. Y.** American and European Trade at Tampico (Mexico). *Rep. Cons. U.S.*, No. 35, pp. 22-24. [1883.]
1269. **Castales, —.** [Coal Mines in Cuba.] *Amer. Journ.* (ser. 1), vol. xlii, pp. 388-390. [1842.]
1270. **Castel, —.** Rapport sur une explosion d'hydrogène carboné dans les travaux d'une mine de fer. *Ann. Mines*, sér. 5, t. vi, pp. 94-99. [1854.]
1271. ——— Sur les schistes bitumineux de Vagnas (Ardèche). *Compt. Rend.*, t. lxiv, pp. 1183-1185. [1867.]
1272. **Castel, C.** Descripción física, geognóstica, agrícola y forestal, de la provincia de Guadaluajara. *Bot. Com. map. geol. Españ.*, t. vii, pp. 331-395; vol. viii, pp. 157-264, map, 1:400,000; vol. ix, pp. 123-214. [1880-1882.]
1273. **Castendyck, W.** Petroleum-vorkommen in Mittel-Galicien. *Berggeist*, bd. xviii, pp. 539, 540. [1873.]
1274. **Castro, F. de.** [Asphalt-mine "Santa Teresa," Jurisdiction of Guanabacoa, Cuba.] *Rev. Min.*, t. xi, pp. 618-621. [1860.]
1275. **Cantley, P. P.** Reports for the years 1835 and 1838 on the Trade of Trieste. *Dipl. Cons. Rep.*, ann. ser., nos. 56, 607. [1886, 1889.]
- Cavaillon, L., see Boyer, E.**
1276. **Caventon, E.** Sur un nouvel hydrogène carboné de la série  $C_nH_{2n-2}$ , et des ses combinaisons avec le brome. *Compt. Rend.*, t. lvi, pp. 712-715. [1863.]
1277. **Cazeneuve, P.** Mines et Industries Minières de l'Algérie. *Bull. Soc. Encour. Ind. Nat.*, t. cix, pp. 444-448. [1907.]
1278. **Cazin, —.** Les fontaines ardentes de Châtillon (Haute-Savoie). *Bull. Club. alp. Franç.*, ann. iii, p. 335. [1877.]
1279. **Cecchi-Mengarini, E.** Ricerche sui alcuni petroli italiani. *Gazz. Chim. Ital.*, t. xxix, pt. i, p. 460-470. [1899.]
1280. **Cech, C. O.** Apparat zur vollkommen gefahrlosen Aufbewahrung (und Transportierung auf Schiffen) grossen Mengen von Petroleum, Benzin, etc. *Polyt. Journ.*, vol. exciv, pp. 156-159. [1869.]
1281. ——— Petroleumfunde in Croation. *Verh. k.-k. geol. Reichs.*, 1890, p. 316.
1282. **Cerkez, S.** Briketts aus Lignit und Petroleumrückständen. *Zeitschr. angew. Chem.*, bd. xviii, pp. 171-173. [1905.]
1283. **Cernik, J.** Technische Studien-Expedition durch die Gebiete des Euphrat und Tigris nebst Ein- und Ausgangs-Routen durch Nord-Syrien. *Petermann's Geogr. Mitth.*, erg.-bd. x, h. 44, 45. Pp. 48, 47, 7 pls. [1875, 1876.]
1284. **Cervini, F.** Sulla natura delle acque salso-jodobromiche e solforose di S. Angelo in Pontano, Provincia di Macerata. *Macerata*, 1877.
1285. **Cesàro, G.** La Hatchette et l'Ozocerite. *Ann. Soc. Géol. Belg.*, t. xviii, *Bull.*, pp. lxxxviii-xc. [1891.]
1286. **Chabré, —.** Substitution du Pétrole au Charbon pour la Propulsion des Navires. *Journ. Pét.*, t. x, p. 227. [1910.]
1287. **Chabrier, E.** The Applications of Asphalt. *Proc. Inst. Civ. Eng.*, vol. xliii, pp. 276-295. [1875.]
- Chais, E. H., see Doroschenko, A. S.**
1288. **Chalmers, R.** On Borings for Natural Gas, Petroleum, and Water; also Notes on the Surface Geology of Part of Ontario. *Rep. Geol. Surv. Canada*, n.s., vol. xiv, A, pp. 160-171. [1902.]
1289. **Chamberlin, R. T.** The Gases in Rocks. *Journ. Geol.*, vol. xvii, pp. 534-568. [1909.]
1290. **Chambers, C. J.** The Russian Petroleum Trade. *U.S. Cons. Rep.*, vol. lxxx, pp. 175-216, 1 map. [1902.]
1291. **Chambers, D. M.** The Ozokerite (Mineral-Wax) Mine of the Galizisches Kredit-Bank at Boryslaw, Galicia. *Trans. Inst. Min. Eng.*, vol. xxxiii, pp. 535-539. [1908.]
1292. ——— Notes on the Winning of Crude Oil. *Ibid.*, vol. xxxv, pp. 559-579, pl. xxi. [1908.]
1293. ——— Petroleum in Aegypten. *Petroleum Zeitschr.*, bd. iv, pp. 1110, 1111. [1909.]
1294. **Chambers, E.** *Cyclopedia, or General Dictionary of Arts and Sciences*, 2 vols. Fo, London, 1728.
1295. **Chambers, J. C.** Russian Petroleum Trade. *Rep. Consuls U.S.A.*, vol. xxi, pp. 400-423, map; 549-551. [1887.]
1296. ——— Petroleum Fuel. *Ibid.*, vol. xxii, pp. 522-527. [1887.]
1297. ——— Petroleum Production in Russia for 1898. *Eng. Min. Journ.*, vol. lxvii, p. 503. [1899.]
1298. **Chambrier, A. de.** Sur l'asphalte du Val de Travers. *Journ. Phys.*, t. lvi, pp. 351-354. [1802.]
1299. **Champion, P.** De quelques composés de la paraffine. *Compt. Rend.*, t. lxxiv, pp. 1576-1579. [1872.]

1300. **Chance, H. M.** Hyner's Station Oil Well Section, included in a Detailed Section of Rocks between the Lower Productive Coal Measures (XIII) and the Dark Slates of the Devonian (VIII) in the vicinity of Remov, Clinton Co., Pa. *Proc. Amer. Phil. Soc.*, vol. xvii, pp. 670-672. [1878.]
1301. — I. The Northern Townships of Butler County; II. A Special Survey, made in 1875, along the Beaver and Shenango Rivers, in Beaver, Lawrence, and Mercer Counties. *2nd Geological Survey of Pennsylvania*, V. 8vo, Harrisburg, 1879.
1302. — Report of Progress on the Geology of Clarion County. *Ibid.*, VV. 8vo, Harrisburg, 1880.
1303. — A Revision of the Bituminous Coal Measures of Clearfield County. *Ibid.*, H7. 8vo, Harrisburg, 1884.
1304. — The Anticlinel Theory of Natural Gas. *Trans. Amer. Inst. Min. Eng.*, vol. xv, pp. 1-13. [1886.]
1305. — The Pressure and Composition of Natural Gas. *Proc. Eng. Club Philadelphia*, vol. v, pp. 365-372. [1886.]
1306. **Chancourtois, E. de.** Application du réseau pentagonal à la co-ordination des Sources de Pétrole et des Dépôts Bitumineux. *Compt. Rend.*, t. lvii, pp. 369-373, 421-425, 731-735. [1863.]
1307. **Chandelon, J. T. P.** Sur la Hatchettine de Baldaz-Laloue. *Bull. Ac. Roy. Belg.*, t. v, pp. 673-678. [1838.]
1308. **Chandler, C. F.** Report on the quality of the Kerosene Oil sold in the Metropolitan District. *4th Rep. Metrop. B. H. New York*, pp. 23. [1870.]
1309. — Report on Petroleum as an illuminator, and the advantages and perils which attend its use; with special reference to the prevention of the traffic in dangerous kerosene and naphtha. *New York*, 1871.
1310. — [The Chemistry of Gas Lighting.] *Proc. Amer. Gaslight Assoc.*, vol. ii, pp. 81-120. [1875.]
1311. — Statistics of Petroleum in the United States. *Amer. Chem.*, vol. vi, pp. 251, 252. [1876.]
1312. — President's Address, 1900. *Journ. Soc. Chem. Ind.*, vol. xix, pp. 591-620. [1900.]
1313. **Chandler, R.** Travels in Greece; or an Account of a Tour made at the Expense of the Society of Dilettanti. 4to, London, 1776.
1314. **Chaouriz, H.** [Petroleum in Mesopotamia.] *Echo Mines Metall.*, t. xxviii, p. 54. [1901.]
1315. **Chapman, A.** Reports for the years 1895, 1896, on the Trade of Vera Cruz. *Dipl. Cons. Rep.*, ann. ser., nos. 1681, 1870. [1896, 1897.]
1316. **Chapman, E. T.** On the Synthesis of Butylene. *Journ. Chem. Soc.*, vol. xx, pp. 28-30. [1867.]
1317. **Chardin, J.** Journal du Voyage de Chev. Chardin en Perse et aux Indes Orientales, par la Mer Noire et par la Colchide. Fo, London, 1686.
1318. **Charitschkoff, K. W.,** see **Kharitshkov, K. V.**
1318. **Charlevoix, P. F. X. de.** Histoire et Description Générale de la Nouvelle France, avec le Journal Historique d'un Voyage [1721] fait par ordre du Roi dans l'Amérique Septentrionale. 4to and 12mo, Paris, 1744.
1319. **Chateau, T.** Mémoire sur la position géologique, la composition et les applications des divers bitumes chapoté de l'île de Cuba, . . . *Ann. Génie Civil*, t. iii, pp. 65-76. [1864.]
1320. **Chatterton, A.** Experiments in Pumping with Oil Engines at Melrosapuram (India). *Bull. Dept. Agric. Madras*, vol. iii, pp. 35-51. [1905.]
1321. **Chenevier, A.** Contribution à l'étude des Huiles pour Graissage et plus spécialement des oléonaphthes. *Monit. Scient.*, sér. 4, t. xii, pp. 785-789. [1893.]
1322. **Cherchefscky, N.** Sur la Détermination de la Viscosité. *Rev. Chim. Ind.*, t. xii, pp. 248, 249. [1901.]
1323. — Détermination de la Provenance d'un Naphte on de ses Dérivés. *Compt. Rend.*, t. cl, pp. 1338-1341. [1910.]
1324. — Les Acides du Naphte. *Paris*, 1910.
1325. **Cherchefscky, N.** Ueber die technische Verwendung der Naphthensäuren. *Seifensieder-Zeit.*, bd. xxxviii, pp. 765, 766, 790-792, 816, 817, 852, 853. [1911.]
1326. — [Analysis of mixtures of Ceresin and Paraffin Wax.] *Mut. Grasses*, t. iv, pp. 2235-2239. [1911.]
1327. **Cheshbrough, E. S.** Detroit River Tunnel. *Trans. Amer. Soc. Civ. Eng.*, vol. ii, pp. 233-288. [1873.]
1328. **Chesebrough, W. H.** Vaseline. *Ber. deutsch. chem. Ges.*, bd. vii, p. 1369. [1875.]
1329. **Chesneau, G.** Rapport sur l'Industrie des Huiles de Schiste en France et en Angleterre. Fo, Paris, 1892.
1330. **Chesney, F. R.** The Expedition for the Survey of the Rivers Euphrates and Tigris, carried on by order of the British Government in the years 1835, 1836, and 1837, preceded by geographical and historical notices of the regions situated between the rivers Nile and Indus. 4 vols. 4to, London, 1850.
1331. **Chesvallier, A.** Note sur la méthode employée aux mines et usines de Pyrmont pour obtenir le goudron épuré et l'huile de pétrole. *Journ. Conn. Usuel.*, t. xxii, pp. 176-178. [1835.]
1332. — Sur les Raffineries de Pétrole. *Ann. Hygiène Publ.*, 1864.
1333. — Rapports du Jury international. Exposition Universelle de 1867. 8vo, Paris, 1868.
1334. **Chikashigé, M.** The Use of Carburetted Water-Gas in the Bunsen Burner. *Journ. Gaslight*, vol. xciii, p. 648. [1906.]
1335. **Chilesotti, A.** Sul potere rifrangente di alcuni idrocarburi a nuclei benzolici condensati. *Gazz. Chim. Ital.*, vol. xxx, pt. 1, p. 149-169. [1900.]
1336. **Chivot-Naudé, —.** Rapport sur l'huile de pétrole. Ses propriétés et ses applications. *L'invention*, ann. xxi, pp. 43-52. [1866.]
1337. **Chlopik, G. V.,** see **Khlopik, G. V.**
1337. **Chochlov, M. I.,** see **Khodzko, M. I.**
1337. **Chodzko, —.** see **Khodzko, —.**
1337. **Choffat, P.** Nouvelles données sur les vallées tiphoniques et sur les éruptions d'ophite et de teschenite en Portugal. *Comm. Trab. Geol. Port.*, t. i, pp. 113-122. [1883.]
1338. **Choraz, J. L.** L'Industrie Pétrolière à Terre-Neuve. *Journ. Pét.*, t. x, p. 115. [1910.]
1339. **Chosson, —.** De la Situation de l'Industrie des Schistes bitumineux du Bassin d'Autun. *Ann. Mines*, sér. 6, t. x, pp. 347-428. [1871.]
1340. **Christensen, J. C.** The Refining of Californian Crude Oil. *Petrol. Rev.*, vol. xviii, pp. 17, 18, 47, 48. [1908.]
1341. **Christison, R.** Chemical Examination of the Petroleum of Rangoon. *Trans. R. Soc. Edinb.*, vol. xiii, pp. 118-123. [1836.]
1342. **Christy, S. B.** Quicksilver Reduction at New Almaden [California]. *Trans. Amer. Inst. Min. Eng.*, vol. xiii, pp. 547-584, 5 pls. [1885.]
1343. **Church, A. H.** Note on the Minerals Dysodile and Albertite. *Chem. News*, vol. vi, pp. 123, 123. [1862.]
1344. — On Tasmanite, a new mineral of organic origin. *Phil. Mag.*, ser. 4, vol. xxviii, pp. 465-470. [1864.]
1345. **Church, A. T.** Notes on Oil Fuel and its Combustion. *Journ. Amer. Soc. Naval Eng.*, vol. xxiii, pp. 795-831. [1911.]
1346. **Cisneros, G. L.** Ueber die physikalischen Eigenschaften des Benzols und des Thiophens. *Ber. deutsch. chem. Ges.*, bd. xxii, pp. 27-30. [1889.]
1347. **Cioabanu, G.,** and **V. Iscu.** [The Balcoiu Oil Field.] *Petrol. Roman.*, 1906.
1348. **Cisneros, C. B.** Le pétrole au Péron. *Bull. Soc. Géogr. Comm. Bordeaux*, sér. 2, t. xvii, pp. 247-251. *El Peru in Europa (Lima)*. [1894, 1901.]
1349. **Clessen, C.** Ueber Dopplert. *Chem.-Zeit.*, bd. xxii, p. 523. [1898.]
1350. **Clapp, F. G.** The Niveveh and Gordon Oil Sands in Western Greene County, Pa. *Bull. U.S. Geol. Surv.*, no. 285, pp. 362-366. [1906.]
1351. — Economic Geology of the Amity Quadrangle, eastern Washington County, Pennsylvania. *Ibid.*, no. 300. Pp. 145, 8 pls. [1907.]

1352. **Clapp, F. G.** Amity, Pa. Fo. 144, *U.S. Geol. Surv.* [1907.]
1353. ——— Rogersville, Pa. Fo. 146, *U.S. Geol. Surv.* [1907.]
1354. ——— Studies in the Application of the Anticlinal Theory of Oil and Gas Accumulations. *Econ. Geol.*, vol. iv, pp. 563-570. [1909.]
1355. ——— A Proposed Classification of Petroleum and Natural Gas Fields, based on Geological Structure. *Ibid.*, vol. v, pp. 503-521. [1910.]
1356. ——— Structure of the Northern Portion of the Eureka-Volcano-Burning-Springs Anticline, in Pleasants, Wood, and Ritchie Counties, West Virginia. *Bull. Geol. Soc. Amer.*, vol. xxi, p. 769. [1910.]
1357. ——— Some Instances of Flowing Wells on Anticlines. *Ibid.*, p. 770. [1910.]
1358. ——— The Use of Geological Science in the Petroleum and Natural Gas Business. *Proc. Eng. Soc. W. Penns.*, vol. xxvi, pp. 87-120. [1910.]
1359. ——— Present and future of Natural Gas Fields in the Northern Appalachians. *Nat.-Gas. Journ.*, vol. lv, no. 3, pp. 2-6. [1910.]
1360. ——— Notes on the Occurrence of Oil and Gas Accumulations in Formations having Monoclinical Dips. *Econ. Geol.*, vol. vi, pp. 1-12. [1911.]
1361. ——— The Occurrence of Oil and Gas Deposits associated with Quaquaversal Structure. *Ibid.*, vol. vii, pp. 364-381. [1912.]
1362. **Clapp, F. G.**, see **Fuller, M. L.**, and **Stones, R. W.**
1362. **Clark, H. A.** The Diesel Engine. *Proc. Inst. Mech. Eng.*, 1903, pt. 3, pp. 395-455.
1363. **Clark, N. B.** Petroleum as a Source of Emergency Power for War-ships. *Proc. U.S. Nav. Inst.*, vol. ix, pp. 798-802. [1883.]
1364. **Clark, T. E.** Ueber den Fichtelit. *Ann. Chem. Pharm.*, bd. ciii, p. 236-247. [1857.]
1365. ——— Fichtelit. A fossil Carbohydrogen found in the Fichtelgebirge of North Bavaria. 8vo, *Heidelberg*, 1857.
1366. ——— Ueber die Krystallform des Fichtelits. *Ann. Chem. Pharm.*, bd. cxix, pp. 226-228. [1861.]
1367. **Clarke, E. D.** Analysis of one hundred parts of a dark Bituminous Limestone from the Parish of Whitford, in Flintshire, North Wales. *Trans. Geol. Soc.*, vol. iv, pp. 430-433. [1817.]
1368. **Clarke, F. T.** High Boiler Efficiency with Oil Fuel. *Power*, vol. xxxiii, pp. 720-723. [1911.]
1369. **Clarke, F. W.** The Data of Geochemistry. *Bull. U.S. Geol. Surv.*, no. 330. Pp. 716. [1908.]
1370. **Clarke, J. M.** Early Devonian History of New York and Eastern North America. 60th *Ann. Rep. New York State Mus.*, 1906, vol. 4, appendix 7. Pp. 366, 5 pls, 4 maps, pls. A, B, 1-xlviii. [1908.]
1371. **Clarke, W. B.** On the Occurrence and Geological position of Oil-bearing Deposits in New South Wales. *Quart. Journ. Geol. Soc.*, vol. xxii, pp. 439-448. [1866.]
1372. ——— Notes on the Geology of Western Australia. *Geol. Mag.*, vol. iii, pp. 503-506, 551-557. [1866.]
1373. ——— On the Transmutation of Rocks in Australasia. *Trans. Phil. Soc. N.S. Wales*, vol. 1, pp. 267-308. [1866.]
1374. ——— Remarks on the Sedimentary Formations of New South Wales, illustrated by references to other provinces of Australasia. 8vo, *Sydney*, 1867.
1375. **Claudel, H.** Nouveau gazogene à combustibles liquides, applicable à tous moteurs à explosion. *Mém. Soc. Ing. Civ.*, 1904, t. 1, p. 422-425.
1376. **Claus, C.**, see **Göbel, F.**
1377. **Clausmann, P.**, see **Gautier, E. J. A.**
1376. **Clavenad, C.** Notice sur les Chaudières marines au goudron liquide de Pétrole. 8vo, *Paris*, 1894.
1377. **Claypole, E. W.** The Future of Natural Gas. *Amer. Geol.*, vol. 1, pp. 31-36. [1888.]
1378. ——— Singular Subterranean Commotion near Akron, Ohio. *Ibid.*, pp. 190-192. [1888.]
1379. ——— Notes on Petroleum in California. *Ibid.*, vol. xxvii, pp. 150-159. [1901.]
1380. **Claypole, E. W.** The Devonian Era in the Ohio Basin. *Amer. Geol.*, vol. xxxii, pp. 15-41, 97-104, 240-250, 312-322, 335-353, pls. iv-x, xvi-xviii. [1903.]
1381. **Clayton, J.** Experiments concerning the Spirit of Coals. *Phil. Trans.*, vol. xii, p. 59. [1739.]
1382. **Clayton, J. E.** [Ozokerite of Utah.] *Eng. Min. Journ.*, vol. xxxix, pp. 168, 169. [1855.]
1383. **Cleland, J. E.** "Barisal Guns" in Western Australia. *Nature*, vol. lxxviii, pp. 101-102. [1908.]
1384. **Clément, —.** Le Pétrole aux Indes Néerlandaises. *Ann. Mines*, sér. 10, t. xviii, pp. 386-433, pl. viii. [1910.]
1385. **Clement, L.**, see **Nicolardot, P.**
1385. **Clements, J.** 1. Device for Using Crude Oil for Bench Fuel. 2. Device for Using Crude Oil for Gas Enrichment. [Wrinkles, Pacific Coast Gas Assoc.] *Amer. Gas Light Journ.*, vol. lxxv, pp. 367, 368. [1901.]
1386. **Clemson, T. G.**, see **Taylor, R. C.**
1386. **Clerc, —.** Voyage dans le pays du Pétrole (Amérique du Nord). *Paris*, 1882.
1387. **Clercy, J. de.** L'Industrie de l'Ozokerite en Galicie. *Gen. Civ.*, t. xxiv, p. 106, 107. [1893.]
1388. **Clerk, D.** On the Explosion of Homogeneous Gaseous Mixtures. *Proc. Inst. Civ. Eng.*, vol. lxxxv, pp. 1-53, pl. 1. [1886.]
1389. ——— The Gas Engine. 8vo, *London*, 1886.
1390. ——— Internal Combustion Engines. *Cantor Lectures*, vol. viii, 1905.
1391. ——— The Testing of Petrol Engines. *Proc. Inst. Autom. Eng.*, vol. vii, pp. 22. [1905.]
1392. ——— The Limits of Thermal Efficiency of Internal Combustion Engines. *Proc. Inst. Civ. Eng.*, vol. clxix, pp. 121-182. [1907.]
1393. ——— The Present Position of Gas and Petrol Engines. *Electrician*, vol. lix, pp. 674-677. [1907.]
1394. ——— The Principles of Carbureting as determined by Exhaust Gas Analysis. *Proc. Inst. Automob. Eng.*, n.s., vol. ii, pp. 47-100. [1907.]
1395. ——— Gaseous Explosions. *Gas and Oil Power*, vol. v, pp. 8-11, 15, 16. [1909.]
1396. **Clipperton, R. C.** Reports for the years 1885-1889, 1891-1893, and 1892, on the Trade of Philadelphia and District. *Dipl. Cons. Rep.*, ann. ser., nos. 177, 464, 731, 1078, 1397, and 1910. [1887-1897.]
1397. **Cloez, S.** Étude des produits formés par l'action de l'acide chlorhydrique sur la fonte et l'acier. *Compt. Rend.*, t. lxxviii, pp. 1565-1569. [1874.]
1398. ——— Nature des hydrocarbures produits par l'action des acides sur la fonte blanche miroitante manganésifère. *Ibid.*, t. lxxxv, pp. 1003-1006. [1877.]
1399. ——— Production d'hydrogènes carbonés liquides et gazeux par l'action de l'eau pure sur un alliage carburé de fer et de manganèse. *Ibid.*, t. lxxxvi, pp. 1248-1251. [1878.]
1400. **Clowes, F.** The Detection and Estimation of small quantities of Inflammable Gas or Vapour in the Air. *Cantor Lectures*, vol. v. [1894.]
1401. ——— The New Table Photometer and Pentane 10-Candle Lamp. *Trans. Incorpor. Gas Inst.*, 1901, pp. 69-85.
1402. **Clowes, F.**, and **B. Redwood.** The Detection and Measurement of Inflammable Gas and Vapour in the Air. 8vo, *London*, 1896.
1403. **Coates, C. E.** The Series  $C_nH_{2n-2}$  in Louisiana Petroleum. *Journ. Amer. Chem. Soc.*, vol. xxviii, pp. 384-388. [1906.]
1404. **Coates, C. E.**, and **A. Best.** The Hydrocarbons in Louisiana Petroleum. *Journ. Amer. Chem. Soc.*, vol. xxv, pp. 1153-1158. [1903]; vol. xxvii, pp. 1317-1321. [1905.]
1405. **Coats, O. P.** Map of the Alleghany Oil Fields, *Wellsville, N.Y.*
1406. **Cobalescu, G.** Memorie geologie ale Scoalei Militare din Iasi. Studii geologie si paleontologie asupra unor teramuri terciari di unele parti ale Rumaniei. *Bucharest*, 1883.



1407. **Cobalcescu, G.** Despre originea si module de zacere al petrolului in general si in particular in Carpati. *An. Acad. Rom.*, t. ix, 1887.
1408. **Codazzi, —**. Jeographia Fisica i Politica de los Provincias de la Nueva Granada. 4to, *Boyota*, 1858.
1409. **Coffiguer, C.** Sur un nouveau procédé de désodorisation des Essences de Pétrole. *Rev. Chem. Ind.*, t. xviii, p. 261. [1907.]
1410. **Coghlan, T. A.** A Statistical Account of the Seven Colonies of Australasia. (Biennial) 8vo, *Sydney*, 1886-1910.
1411. ——— New South Wales Statistical Register. (Annual). 8vo, *Sydney*, 18—.
1412. ——— The Mining Industry of New South Wales. 8vo, *Sydney*, 1900.
1413. **Cogniet, L.** Les huiles minérales au point de vue de leur emploi pour le chauffage des machines à vapeur. 8vo, *Paris*, 1868.
1414. **Cohen, J. B., and C. P. Finn.** Paraffins from a Yorkshire Coal Seam. *Journ. Soc. Chem. Ind.*, vol. xxxi, pp. 12-15. [1912.]
1415. **Coignard, —**, etc. Bulletin des travaux de Chimie exécutés en 1900, par les Ingénieurs des Mines dans les Laboratoires départementaux. *Ann. Mines*, sér. 10, t. ii, pp. 259-277. [1902.]
1416. **Colburn, L. C.,** see **Slosson, E. E.**
1416. **Colbre, L.** Les Salines et les Puits de Fen de la Province du Se-Tchouan. *Ann. Mines*, sér. 8, t. xix, pp. 441-528, pls. xiii-xv. [1891.]
1417. **Cole, G. A. J.** The Unnatural History of an Oil Well [in Dublin]. *Irish Nat.*, vol. xii, pp. 141-144. [1903.]
1418. **Coleman, A. P., and W. H. Ellis.** Anthraxolite or Anthracitic Carbon. *Rep. Bureau Mines Ontario*, no. 6, pp. 159-166. [1896.]
1419. **Coleman, J. J.** On Mineral Oil as a Lubricant. *Trans. Inst. Eng. Shipbuild. Scotland*, vol. xvi, pp. 37-55. [1873.]
1420. ——— The effects of Pressure and Cold upon the Gaseous Products of the Distillation of Carbonaceous Shales. *Journ. Chem. Soc.*, vol. xxviii, pp. 856-861. [1875.]
1421. ——— On the Methods in Use for Testing Hydrocarbon Illuminating Oils. *Chem. News*, vol. xxxi, p. 147. [1875.]
1422. ——— Sur l'inflammabilité relative des huiles d'origine animale, végétale et minérale. *Bull. Soc. Ind. Mulh.*, t. xlv, pp. 104-107. [1876.]
1423. ——— Notes on Viscosity and other Tests for Oils. *Journ. Soc. Chem. Ind.*, vol. v, pp. 359-361. [1886.]
1424. **Colin, E.** Notice sur l'éclairage aux huiles minérales. *Paris*, 1870.
1425. **Collett, J.** Geological Reconnaissances of Jasper, White, Carroll, Cass, Miami, Wabash, and Howard Counties, Indiana. *Ann. Rep. Geol. Surv. Indiana*, vol. iv, pp. 291-337. [1872.]
1426. ——— Geology of Knox County. *Ibid.*, vol. v, pp. 315-382. [1874.]
1427. ——— Geology of Brown County, Indiana. *Ibid.*, vol. vi, pp. 76-109. [1875.]
1428. ——— Geological Report on Harrison and Crawford Counties, Indiana. *Ibid.*, vols. viii, ix, and x (in one), pp. 291-522. [1879.]
1429. ——— Twelfth Annual Report of the Department of Geology and Natural Resources of Indiana. [1883.]
1430. **Collie, J. E.** A Two-muffle Oil-burning Assay Furnace. *Austral. Min. Stand.*, vol. xiv, p. 12. [1911.]
1431. **Collin, —**, see **Guilbert, —**.
1431. **Collingwood, C.** On some Sources of Coal in the Eastern Hemisphere, namely Formosa, Labuan, Siberia, and Japan. *Quart. Journ. Geol. Soc.*, vol. xxiv, pp. 98-102. [1868.]
1432. **Collingwood, F.** Water-proof Coverings. *Trans. Amer. Soc. Civ. Eng.*, vol. ix, pp. 348-352. [1880.]
1433. **Collins, B. R. T.** Oil Fuel for Steam Boilers (and Discussion). *Journ. Amer. Soc. Mech. Eng.*, vol. xxxiii, pp. 929-965. [1911.]
1434. **Collins, J. H.** Newfoundland, its Mineral and other Resources. 8vo, *London*, 1898.
1435. **Colnaghi, D. E.** Reports for the years 1889 and 1893 on the Trade of Venice and Ancona. *Dipl. Cons. Rep.*, ann. ser., nos. 809, 1496. [1890, 1895.]
1436. **Colomer, F., and C. Lordier.** Combustibles Industriels. Houille, Pétrole, Lignite, Tourbe, Bois, Charbon de Bois, Agglomérés, Coke. *Paris*, 1903.
1437. **Combes, C.** Notice sur les nouveaux perfectionnements, apportés par M. O. G. Kind, aux instruments de sondage. *Bull. Soc. Encour. Ind. Nat.*, 1845, pp. 344-348, pl. 966.
1438. **Combes, —**, — **Villot, and — Pirondi.** Mode d'Emmagasinage des Huiles de Pétrole, de Schiste, etc., par M.M. Bizard et Labarre. 1°. Rapport au Comité Consultatif des Arts et Manufactures. 2°. Rapport à Son Excellence M. le Ministre de l'Agriculture, du Commerce et des Travaux Publics, sur un nouveau Reservoir pour l'Emmagasinage des Huiles Minérales. 3°. Rapport au Conseil d'Hygiène du Département des Bouches-du-Rhône. *Ann. Mines*, ser. 6, t. xi, pp. 185-206. [1867.]
1439. **Comstock, T. B.** A Preliminary Report on Parts of the Counties of Menard, Concho, Tom Green, Sutton, Schleicher, Crockett, Val Verde, Kinney, Maverick, Uvalde, Edwards, Bandera, Kerr, and Gillespie. *Rep. Geol. Surv. Texas*, pp. 43-54. [1892.]
1440. **Condamine, De la.** Les gisements pétrolières du Wyoming. *Compt. Rend. Soc. Industr. Min.*, 1908, pp. 7-9.
1441. **Condra, C.** [Physico-chemical Reactions in the Refining of Petroleum with Sulphuric Acid.] *Rev. Gén. (Bucharest)*, t. v, pp. 83-86. [1900.]
1442. **Cone, A., and W. R. Johns.** Petrolia. A Brief History of the Pennsylvania Petroleum Region, its development, growth, resources, etc., from 1859 to 1869. 8vo, *New York*, 1870.
1443. **Conradus, D.** Description curieuse d'une fontaine ardente et médicinale en Pologne, avec l'explication de ce phénomène par J. Denis. *Act. Erudit. Lips.*, 1684, p. 326.
1444. **Contejean, C.** Une excursion au Macaluba de Girgenti [Sicile]. *Rev. Sci.*, t. xxxi, pp. 720-724. [1883.]
1445. ——— Boules argileuses de Macaluba. *Compt. Rend.*, t. xciv, pp. 1238, 1239. [1883.]
1446. **Conti, C.** Distretto di Caltanissetta. *Ann. Agric. Rel. Ser. Min.*, 1889, pp. 37-88. [1883.]
1447. **Conybeare, J. J.** Examination of Mumia, etc. *Ann. Phil.*, vol. xxi, pp. 124-127. [1823.]
1448. ——— On Hatchetine. *Ibid.*, pp. 190-193. [1823.]
1449. **Cook, E. F.** The Pharmacy of Liquid Petroleum. *Amer. Journ. Pharm.*, vol. lxxv, pp. 260-264. [1903.]
1450. **Cook, J.** Voyages and Travels through the Russian Empire, Tartary, and part of the Kingdom of Persia. 2 vols. 8vo, *Edinburgh*, 1770.
1451. **Cooke, M. C.** Naphtha. *Journ. Soc. Arts*, vol. vii, pp. 638-642. [1859.]
1452. **Cookson, C. A.** Reports for the years 1888-1892 on the Trade of Alexandria. *Dipl. Cons. Rep.*, ann. ser., nos. 685, 767, 944, 1113, 1276. [1889-1893.]
1453. **Cooper, A. S.** The Genesis of Petroleum and Asphalt in California. *Sci. Amer. Suppl.*, vol. xxxvi, pp. 14738-14740. [1893.]
1454. ——— A Bituminous Rock Deposit in Santa Barbara County, California. *Eng. Min. Journ.*, vol. lxxvi, pp. 278, 279. [1898.]
1455. ——— Southern California Petroleum [U.S.A.]. *Min. Sci. Press*, vol. lxxvii, p. 373. [1898.]
1456. ——— The Genesis of Petroleum and Asphaltum in California. *Bull. Calif. Min. Bureau*, No. 16, pp. 89. [1899.]
1457. ——— Phenomena Accompanying the Accumulations of Bitumen. *Min. Sci. Press*, vol. lxxix, pp. 632, 633, 665, 691, 721. [1899.]
1458. ——— The Origin and Occurrence of Petroleum in California. *Min. Industry*, vol. ix, pp. 505-509. [1901.]
1459. ——— Some Chemical and Physical Characteristics of California Petroleum. [Pacific Coast Gas Assoc.] *Amer. Gas Light Journ.*, vol. lxxiii, pp. 282-285. [1901.]

1460. **Cooper, A. S.**, and **H. N. Cooper.** Taking Gasoline from Natural Gas. *Petrol. Rev.*, vol. xviii, p. 257. [1908.]
1461. **Cooper, H. N.** Chemical Analyses of California Petroleum. *Bull. Calif. State Min. Bureau*, no. 31. [1904.]
- Cooper, H. N.**, see **Cooper, A. S.**
- Cooper, J. C.**, see **Watts, W. L.**
1462. **Cooper, T.** New Theory of the Formation of Coal [Doppelite]. *Eng. Min. Journ.*, vol. xxxii, p. 103, [1881.]
- Cooper, W. J.**, see **Wanklyn, J. A.**
1463. **Copeutt, J.** Cottage Gas Works, Gas Works for Towns, etc., explained. Ed. iii. 12mo, London. [1860.]
1464. **Coppodoro, A.** Sopra alcuni asfalti di Sicilia. *Rend. Soc. Chim. ital.*, ser. 2, vol. ii, pp. 92-97. [1910.]
1465. **Coppelovici, M.** [Recording Apparatus in Petroleum Drilling.] *Revista Petrolului*, t. i, pp. 78, 79. [1908.]
1466. **Coppi, F.** Brevi note sulle Salse modenesi. *Boll. R. Com. geol. Ital.*, 1875, pp. 231-237.
1467. **Coquand, H.** Des sulfates, des aluminés et des laguni de la Toscane. *Bull. Soc. Géol. France*, sér. 2, t. vi, pp. 91-160. [1848.]
1468. — Sur les gites de Pétrole de la Valachie et de la Moldavie, et sur l'âge des Terrains qui les contiennent. *Ibid.*, sér. 2, t. xxiv, pp. 505-569. [1867.]
1469. — Description géologique des Gisements Bitumineux et Pétrolifères de Selenitza dans l'Albanie, et de Chieri dans l'île de Zante. *Ibid.*, sér. 2, t. xxv, pp. 20-74. [1868.]
1470. — Sur les Gisements Asphaltiques des environs de Ragusa, dans la Province du Val di Noto [Sicile]. *Ibid.*, pp. 420-430. [1868.]
1471. — Description des terrains à Pétrole et à Ozokérite du versant septentrional du Caucase. *Ibid.*, sér. 3, t. vi, pp. 86-99. [1878.]
1472. **Coquillou, J. J.**, and **J. Henrivaux.** Sur la transformation des carbures d'hydrogène en présence de la vapeur d'eau aux températures élevées. *Journ. Usines Gaz*, ann. xiv, pp. 355-358. [1890.]
1473. **Corazzi, E.** Dissertationes tres . . . 2. De Ignibus Etruscis, ad naturæ leges expensis. [? Bologna, 17—.]
1474. **Corbu, J.** Le Pétrole et les Torpilleurs. *Mon. Inst. Pétrol. Roum.*, t. x, 1909.
1475. **Cordella, A.** La Grèce sous le Rapport Géologique et Minéralogique. 8vo, Paris, 1878.
1476. **Cordus, Valerius.** Observationes quadam Rerum Naturalium variarum. Zurich, 1560.
1477. **Corkill, E. T.** Petroleum and Natural Gas [of Ontario]. *Rep. Bureau Mines Ontario*, vol. xiv, pp. 89-117. [1905.]
1478. **Cornwall, H. B.** Kerosene Oil. *Amer. Chem.*, vol. vi, pp. 458-460. [1876.]
1479. — Petroleum. *Pop. Sci. Monthly*, vol. ix, pp. 140-157. [1876.]
1480. **Cossham, H.** Coal and its Uses. *Coll. Guard.*, vol. xxvii, pp. 960, 961, 990-992. [1877.]
1481. **Costa, O. G.** Note relative alla miniera di asfalto di Roccasecca ed agli usi cui può utilmente impiegarsi per socio ordinario. *Atti. Ist. Incor. Napoli*, ser. 2, t. ii, pp. 223-237. [1865.]
1482. — Notizie sui Pozzi Modenesi. *Mem. R. Acc. Sci. Modena*, t. ix, 1868.
1483. — Rapporto sulle miniere esistenti nelle provincie meridionali del regno italiano. *Atti R. Ist. Incor. Napoli* [ser. 1], t. x, pp. 369-384. [1863.]
1484. **Costa Senna, J. C. da.** A riqueza petrolifera d'Angola. *Soc. geogr. Lisbon*, 1908, pp. x, 15.
1485. **Costachescu, N.** Les Gas contenus dans le Sel gemme et dans les Volcans de Boue de Roumanie. *Ann. Sci. Univ. Jassy*, t. iv, pp. 3-59. [1906.]
1486. — Sur un heptane secondaire contenu dans le pétrole roumain. *Ibid.*, t. vi, pp. 294-301. [1910.]
- Costachescu, N.**, see **Poni, P.**
1487. **Coste, E.** Statistical Report of the Production, Value, Exports and Imports of Minerals in Canada during the year 1886 and previous years. *Ann. Rep. Geol. Surv. Canada*, n.s., vol. ii, report 8, pp. 85. [1887.]
1488. — Report on the Mining and Mineral Statistics of Canada for the year 1887. *Ibid.*, n.s., vol. iii, report 8, pp. 110. [1889.]
1489. — On Natural Gas in Ontario. *Journ. Canad. Min. Inst.*, vol. iii, pp. 68-69. [1900.]
1490. — Volcanic Origin of Oil. *Journ. Franklin Inst.*, vol. civ, pp. 443-454. [1904.]
1491. — Volcanic Origin of Natural Gas and Petroleum. *Journ. Canad. Min. Inst.*, vol. vi, p. 73. [1904.]
1492. — The Volcanic Origin of Oil. *Trans. Amer. Inst. Min. Eng.*, vol. xxxv, pp. 288-297. [1905.]
1493. — Natural Gas and Petroleum. *Rep. Bureau Mines Ontario*, vol. xv, pp. 108-115. [1906.]
1494. — The New Tilbury and Romney Oilfields of Kent County, Ontario. *Journ. Canad. Min. Inst.*, vol. x, pp. 77-84. [1908.]
1495. — The Volcanic or Organic Origin of Oil. *Mining Science*, vol. ix, pp. 367, 368. [1909.]
1496. — Petroleum and Coals compared in their Nature, Mode of Occurrence, and Origin. *Journ. Canad. Min. Inst.*, vol. xii, pp. 273-301, 643-645. [1910.]
1497. — Fallacies in the Theory of the Organic Origin of Petroleum. *Bull. Inst. Min. Metall.*, no. 85. Pp. 18. [1911.]
1498. **Coste, J. H.** Note on the Determination of Petroleum in Turpentine. *Analyst*, vol. xxxiv, pp. 148-151. [1909.]
1499. — The Examination of Turpentine Substitutes and the Determination in Turpentine of Hydrocarbons other than Terpenes. *Ibid.*, vol. xxxv, pp. 112-117. [1910.]
1500. — The Caloric Power of Gas. A Treatise on Caloric Standards and Calorimetry. London, 1911.
1501. **Coste, J. H.**, and **E. T. Shelbourn.** Lubricating Oils. *Proc. Assoc. Eng. Charge*, vol. x, no. 5. Pp. 16. [1905.]
1502. **Cotta, B. v.** Ueber das Vorkommen und die Gewinnung des Erdöls in Galizien. *Oesterr. Zeitschr. Berg- Hütt.*, bd. xiv, pp. 149, 150. [1866.]
1503. **Cotter, G. de P.** The Southern Part of the Gwegyo Hills, including the Payagyigon-Ngashandoung Oilfield. *Rec. Geol. Surv. Ind.*, vol. xxxvii, pp. 225-234, pls. x, xi. [1909.]
1504. — The Northern Part of the Yenangyat Oilfield. *Ibid.*, pp. 302-307, pls. xxviii, xxix, xxxix. [1910.]
1505. **Coûlaine, H. de.** Recherches sur l'emploi des substances bitumineuses dans la construction des chaudières, sur la nature, la composition, les propriétés de ces substances, et leurs diverses applications. *Ann. Ponts Chauss.*, t. xix, pp. 240-308. [1850.]
1506. **Coupan, G.** Considérations sur la Culture Mécanique du Sol: Charrue Automobile, Système Riester-Picard. *Gen. Civ.*, t. lix, pp. 305-309. [1911.]
1507. **Courtis, W. M.** The Animikie rocks and their Veln-phenomena as shown at Duncan Mine, Lake Superior. *Trans. Amer. Inst. Min. Eng.*, vol. xv, pp. 671-677. [1887.]
1508. **Covelli, N.** Memoria intorno ad una escursione fatta negli Abruzzi per la ricerca del carbon fossile (1828). *Atti R. Ac. Sc. Napoli*, vol. iv, pp. 105-118. [1839.]
1509. **Cowan, D.** On Mineral Oil Works. *Trans. N. Engl. Inst. Min. Eng.*, vol. xx, pp. 177-184, pls. xlix-liii. [1870.]
- Coward, H. F.**, see **W. A. Bone**, and **Dixon, H. B.**
1510. **Cox, H.** An account of the Petroleum Wells in the Burmese Dominions, extracted from the journal of a voyage from Ranghoo [Rangoon] up the River Eral Whuddey [Irawadi] to Amaraoporah, the present capital of the Burma Empire. *As. Res.*, vol. vi, pp. 127-137. [1799.]

1511. **Cox, H.** A brief Account of the Religions and Civil Institutions of the Burmans, and a Description of the Kingdom of Assam. To which is added an account of the Petroleum Wells in the Burman Dominions. *Calcutta*, 1826.
1512. **Cox, S. H.** Prospecting for Minerals: a practical handbook for Prospectors, Explorers, Settlers and all interested in the Opening-up and Development of New Lands. 8vo, *London*, 1898.
1513. **Crace-Calvert, F.** On the Testing of Petroleum Spirit. *Chem. News*, vol. xxi, pp. 85, 86. [1870.]
1514. **Cracraft, W., etc.** Report of a Committee for investigating the Coal and Mineral Resources of India. 8vo, *Calcutta*, 1838.
- Crafts, J. M.,** see **Friedel, C.**
1515. **Crafts, S. P.** Burning Brick. *Rep. Nat. Brick Manuf. Assoc.*, vol. iii, pp. 100-112. [1888.]
1516. **Craggs, E. H.** On vessels constructed for the over-sea Bulk Oil Trade. *Proc. Cleveland Inst. Eng.*, 1893, pp. 8-37.
1517. **Craig, E. H. C.** The Geological Structure of Trinidad. Pt. 8. 8vo, *Port-of-Spain*, 1905.
1518. ——— Oilfields of Trinidad. Mayaro-Guaya-guayare Oilfield. *Council Paper*, 1905, no. 25. Pp. 12; 3 pls.
1519. ——— *Idem.* General Report on the Southern Anticline of the Oilfields. *Ibid.*, no. 119. Pp. 14, map.
1520. ——— The Oilfields of Trinidad. *Journ. Roy. Colonial Inst.*, vol. xxxvii, pp. 487-502. [1906.]
1521. ——— Oilfields of Trinidad. Special Report on the Cedros District. *Council Paper*, 1906, no. 12. Pp. 7, map.
1522. ——— Preliminary Report on the Guapo and La Brea District. *Ibid.*, no. 30. Pp. 4.
1523. ——— *Idem.* Supplementary Report on the San Fernando Manjak Field, Trinidad. *Ibid.*, no. 35. Pp. 6, map.
1524. ——— *Idem.* General Report on the Central and Northern Anticlines (Western Districts). *Ibid.*, 1907, no. 60. Pp. 19; 2 pls.
1525. ——— *Idem.* Report on the Oilfields of the Central Anticline (Central District). *Ibid.*, no. 131. Pp. 7, map.
1526. ——— The Oilfields of Trinidad. *West India Committee Circular*. [1911.]
- Cram, M. P.,** see **Gilpin, J. E.**
1527. **Crampton, C. R., and D. Tait.** On certain New Localities for Oil-bearing Shale near Edinburgh. *Trans. Edinb. Geol. Soc.*, vol. ix, pp. 102-107. [1908.]
1528. **Crane, C. H.** High-speed Gasoline Launches. *Trans. Soc. Naval Arch. Eng.*, vol. xii, pp. 321-325. [1904.]
1529. **Crane, W. E.** Crucible Furnace for Burning Petroleum. *Trans. Amer. Soc. Mech. Eng.*, vol. xv, pp. 307-312. [1894.]
1530. **Crane, W. R.** Kansas Natural Gas. *Mines and Minerals*, vol. xxiii, pp. 245-247. [1903.]
1531. ——— Asphalt Mining and Refining in Indian Territory. *Eng. Min. Journ.*, vol. lxxv, pp. 926-928. [1903.]
1532. ——— Asphalt Refining. Methods employed in the Tar Springs Asphalt Co.'s refinery near Comanche, I. T. *Mines and Minerals*, vol. xx.ii, p. 337. [1903.]
1533. ——— Asphalt in the Indian Territory. *Min. Ind.*, vol. xiii, pp. 29-31. [1905.]
1534. ——— Asphaltic Coal in the Indian Territory. *Mines and Minerals*, vol. xxvi, pp. 252-255. [1906.]
- Crane, W. R.,** see **Adams, G. I.**
1535. **Crawford, G. W.** Report on the Trade of Porto Rico for the year 1896. *Dipl. Cons. Rep.*, ann. ser., no. 1917. [1897.]
1536. **Crawford, J. J.** Twelfth and Thirteenth [Biennial] Reports of the State Mineralogist [of California] for the two years ending September 15, 1894, 1896. 8vo, *Sacramento*, 1894, 1896.
1537. **Crawford, R.** Across the Pampas and the Andes. *London*, 1884.
- Crawford, W. H.,** see **Hough, E. S.**
1538. **Crawford, John.** Account of the Embassy to the Court of Ava in 1826. *London*, 1834.
1539. **Credner, C. F. H.** Ueber die Entstehung des Erdöls. *Zeitschr. ges. Nat.*, bd. xxxiii, p. 304. [1869.]
1540. **Credner, H.** Ueber die geognostischen Verhältnisse der Umgegend von Bentheim, und über des Vorkommen des Asphaltites daselbst. *Jahresb. Nat. Hist. Ges. Hannover*, bd. xi, pp. 31-42. [1860.]
1541. ——— Ueber die Grenz-Gebilde zwischen dem Keuper und dem Lias am Seeburg bei Gotha und in Norddeutschland überhaupt. *N. Jahrb.*, 1860, pp. 293-319.
1542. ——— Die Pteroceras-Schichten (Aporrhais-Schichten) der Umgegend von Hannover. *Zeitschr. deutsch. geol. Ges.*, bd. xvi, pp. 196-243, pls. ix-xi. [1864.]
1543. ——— Notiz über das Erdöl-Vorkommen bei Sebnde. *Berggeist*, bd. x, no. 89. [1865.]
1544. ——— Bemerkungen zur geognostischen Karte der Umgegend von Hannover. [1865.]
1545. ——— Die Geognosie und der Mineralreichthum des Alleghany-Systems. *Mith. Geogr. Anst.*, bd. xvii, pp. 41-50. [1871.]
1546. **Crema, C.** Il Petrolio nel Territorio di Tramutola (Petenza). *Boll. Soc. geol. Ital.*, vol. xxi, pp. xxviii-xxviii. [1902.]
1547. **Cresson, Dr. C. M.** Bituminous Material from Pulaski County, Virginia, U.S. *Proc. Amer. Phil. Soc.*, vol. xvii, pp. 215, 216. [1878.]
1548. **Creteur, H.** Bijdragen uit het scheikundig Laboratorium. *Jahr. Mijnc. Ned. O.-Ind.*, jg. ix, dl. 2, pp. 91-102; jg. xiv, Wet., pp. 111-139; jg. xv, Wet., pp. 172-189; jg. xvii, Wet., pp. 83-120; jg. xxi, Wet., pp. 1-55. [1880, 1885, 1886, 1888, 1892.]
1549. **Crew, B. J.** A Practical Treatise on Petroleum; comprising its Origin, Geology, Geographical Distribution, History, Chemistry, Mining, Technology, Uses, and Transportation. 8vo, *Philadelphia*, 1887.
1550. **Cristiani, R. S.** A Technical Treatise on Soap and Candles; with a glance at the Industry of Fats and Oils. 8vo, *Philadelphia and London*, 1881.
1551. **Crovo [C. C. Leonard].** The History of Pithole. *Pithole City*, 1867.
1552. **Crompton, R. E. B.** Some Unsolved Problems of Motor Engineering. *Proc. Inst. Automob. Eng.*, vol. vii, pp. 57. [1906.]
1553. **Cronise, Adelbert.** The Pitch Lake of Trinidad. *Proc. Rochester (N. Y.) Acad. Sci.*, vol. ii, pp. 278-285, pl. 13. [1895.]
1554. **Cronise, T. F.** The Natural Wealth of California. *San Francisco*, 1868.
1555. **Cronquist, A. W.** Part prise par la Suède dans l'Industrie et le Commerce du Pétrole. *Compt. Rend. Congr. internat. Pétrole*, sess. 3, t. ii, pp. 869, 870. [1910.]
1556. **Crosby, W. O.** Native Bitumens and the Pitch Lake of Trinidad. *Amer. Nat.*, vol. xiii, pp. 229-246. [1879.]
1557. ——— Notes on the Physical Geography and Geology of Trinidad. *Proc. Boston Soc. Nat. Hist.*, vol. xx, pp. 44-55. [1879.]
1558. **Crowe, E. F.** Report for the year 1905 on the Trade of Japan. *Dipl. Cons. Rep.*, ann. ser., no. 3675. [1906.]
1559. **Crowley, R. W.** Marine Oil-Engine Power. Present-Day Accomplishments. *Gas and Oil Power*, vol. vi, pp. 247-250. [1911.]
1560. **Crum, A. R., and A. S. Dungan.** The Romance of American Petroleum and Gas. 8vo, *New York*, 1911.
1561. **Cucu, N.** Rumanian Petroleum. 1st *Internat. Petrol. Congr.*, pp. 22-26. [1900.]
- Cucu, N.,** see **Saligny, A.**
1562. **Cumberbatch, H. A.** Report for the year 1890 on the Trade of the District of Consulate-General at Salonica. *Dipl. Cons. Rep.*, ann. ser., no. 962. [1891.]

1563. **Cumberbatch, H. A.** Bitumen and Asphalt Deposits in Syria and Palestine. *Board of Trade Journ.*, vol. lxi, pp. 38, 39. [1908.]
1564. **Cumenge, —.** Étude sur les gisements de charbon et de bitume de la Trinidad. *Ann. Mines*, sér. 8, t. II, pp. 137-184, map and sections. [1882.]
1565. **Cunningham, A. C.** Coorongite; a South Australian Elaterite. *Proc. Roy. Soc. Vict.*, vol. xv, pp. 134-140. [1903.]
1566. **Cummins, A.** Geology of the Natural Gas-fields about Pittsburg. *Eng. Min. Journ.*, vol. liv, pp. 106, 107. [1892.]
1567. **Cummins, W. F.** Report on the Geology of North-Western Texas. *Second Ann. Rep. Geol. Surv. Texas*, 1890, pp. 359-552, pls. xvi and xviii. [1891.]
1568. **Cunningham, P.** Two Years in New South Wales. 8vo, London, 1827.
1569. **Curioni, G.** Sugli scisti bituminosi di Tignale sul lago di Garda. *Giorn. Ist. Lomb.*, t. II, pp. 257-263. [1854.]
1570. ———. Intorno agli scisti bituminosi della valle di Setarolo. *Atti. R. Ist. Lomb.*, t. III, pp. 12-14. [1862.]
1571. ———. Sui giacimenti metalliferi e bituminosi nei terreni trasiadici di Besano. *Mem. R. Ist. Lomb.*, vol. IX, pp. 241-268, 3 pls. [1863.]
1572. ———. Geologia. Parte prima. Geologia applicata delle Provincie Lombarde. Parte seconda. Descrizione Ragionata delle Sostanze Estrattive Utile Metalliche e Terree raccolte nelle Provincie Lombarde. 2 vols. 8vo, Milan, 1877.
1573. **Currier, D.** Oil-Tank Vessels. *Marine Engineering*, vol. viii, pp. 1920. [1903.]
1574. **Curtis, M.**, and **P. W. Tompkins.** Notes on the Determination of Water in California Crude Oils. *Journ. Soc. Chem. Ind.*, vol. xxi, p. 1519. [1902.]
1575. **Garzon, G. N.** Persia and the Persian Question. 2 vols. 8vo, London, 1902.
1576. **Cushing, N. C.** A New Motor Fire Boat. *Ibid.*, vol. XI, pp. 364, 365. [1906.]
1577. **Cushman, A. S.** Oil Cement Concrete. *Science*, n.s., vol. xxxi, p. 960. [1910.]
- Cutter, W. P.**, see **Newbury, S. B.**
1578. **Cutts, H. E.** Notes on Liquid Lubricants. *Marine Engineering*, vol. I, April 1897, pp. 4, 5.
1579. **Cvel, C. K.** [Projected Application of the Force of Compressed Air in the Naphtha-industry of Balakhan-Sabuntchil.] *Trudi Ba'insk. Ud. Imp. Russk. Tekhn. Obsch.*, 1889-1891, pp. 53-63. [1892.]
1580. **Czajek, J.** Geologische Zusammensetzung der Berge bei Mölk, Mauntern und St. Pölten in Niederösterreich. *Jahrb. k.-k. geol. Reichs.*, bd. IV, pp. 264-283. [1863.]
1581. **D——.** Verhalten der Oelsande im Gewinnungsbetrieb. *Petroleum Zeitschr.*, bd. VI, pp. 2070-2074. [1911.]
1582. **D——, K.** Drehbanköle. *Chem.-techn. Fabrik.*, bd. VIII, p. 605. [1911.]
1583. **Daddow, S. H.**, and **B. Bannan.** Coal, Iron and Oil; or the Practical American Miner. 8vo, Pottsville, Pa., 1866.
1584. **Däschner, —.** Procédé de séparation à l'état non décomposé des parties résineuses contenues dans les huiles minérales. *Rev. Prod. Chim.*, ann. IV, p. 309. [1902.]
1585. **Dains, F. B.** On the Composition of a Natural Oil from Wilson County, Kansas. *Trans. Kansas Ac. Sci.*, vol. XIV, pp. 38, 39. [1896.]
1586. **Dakyns, J. R.**, see **Green, A. H.**
1587. **Dale, T. N.** A Study of the Rhætic Strata of the Val di Ledro in the Southern Tyrol. 8vo, New York, 1875.
1588. **Dall, W. H.** Report on Coal and Lignite of Alaska. *Ann. Rep. U.S. Geol. Surv.*, vol. XVII, pt. I, pp. 763-908, pls. xlviii-lviii. [1896.]
1589. **Dal Sie, —.** Ueber einen bituminösen Kalkstein von Ragusa. *Venice*, 1873.
1590. **Dalton, J.** A New System of Chemical Philosophy. *Manchester*, 1808.
1591. **Dalton, L. V.** A Sketch of the Geology of the Baku and European Oilfields. *Econ. Geol.*, vol. IV, pp. 89-117, pl. iii. [1909.]
1592. ———. On the Origin of Petroleum. *Ibid.*, pp. 603-631. [1909.]
1593. **Daly, R.** Report on field operations in the geology of the Mountains crossed by the international boundary (49th parallel). *Ann. Rep. Interior Canada* for 1905. [1906.]
1594. **Damski, A. V.** [On the Paraffins in Petroleum.] *Zap. Imp. Russk. Tekhn. Obsch.*, g. xxiii, Jan., pp. 51-60; Feb., pp. 38-46. [1889.]
1595. ———. [Sakhalin Petroleum] *Ibid.*, Mar., pp. 1-6. [1889.]
1596. ———. [On the Question of the Determination of a Standard of Quality for Burning Fuels generally and for Petroleum Residues in Particular.] *Ibid.*, Dec., pp. 1-36, 1 pl. [1889.]
1597. **Dana, E. S.** On the Trap Rocks of the Connecticut Valley. *Proc. Amer. Assoc.*, vol. xxiii, pp. 46-47. [1874.]
1598. **Dana, J. D.** A System of Mineralogy. 8vo, New York, 1855.
1599. ———. Manual of Geology. 8vo, Philadelphia, 1863.
1600. ———. Text-Book of Geology. 1866.
1601. **Dankwerth, L.** Ueber die Wirkung des Petroleums auf die in den Raffinerien desselben beschäftigten Arbeiter. *Polyt. Journ.*, bd. cxxxvii, p. 271. [1868.]
1602. **Danneberg, J.** Mittheilungen über das Vorkommen der "Naphta" bei Scherach und Eldar in Transkaukasien. *Oesterr. Zeitschr. Berg- u. Hüt.*, bd. xviii, pp. 266-269. [1870.]
- Danset, —**, see **Arbel, —**.
1603. **D'Anthonay, A. J.** Le Pétrole au Mexique. *Journ. Pét.*, t. x, p. 151. [1910.]
1604. **Dantin, C.** Moteurs Thermiques Récentes applications du Moteur Diesel. *Génie Civ.*, t. lix, pp. 261-266. [1911.]
1605. **Darton, N. H.** Preliminary Description of the Geology and Water Resources of the Southern Half of the Black Hills and adjoining Regions in South Dakota and Wyoming. *Ann. Rep. U.S. Geol. Surv.*, vol. xxi, pt. 4, pp. 489-599, pls. lviii-cxii. [1901.]
1606. ———. Preliminary List of Deep Borings in the United States. *Water Supply Papers U.S. Geol. Surv.*, nos. 57 and 61 [1902], no. 149 [1905].
1607. ———. Newcastle, Wyoming. Fo. 107. *U.S. Geol. Survey*, 1904.
1608. ———. Preliminary Report on the Geology and Underground Water Resources of the Central Great Plains. *Prof. Papers U.S. Geol. Surv.*, no. 32. Pp. 433; 72 pls. [1905.]
1609. ———. Geology of the Bighorn Mountains [Wyoming]. *Ibid.*, no. 51. Pp. 129; 47 pls. [1906.]
1610. ———. Mineral Resources of the Bighorn Mountain Region. *Bull. U.S. Geol. Surv.*, no. 285, pp. 303-310. [1906.]
1611. **Darton, N. H.**, and **C. E. Siebenthal.** Geology and Mineral Resources of the Laramie Basin, Wyoming. *Ibid.*, no. 364. Pp. 81; 8 pls. [1908.]
1612. **Daru, N. D.** Oil at Jaba, Mianwali District, Punjab. *Rec. Geol. Surv. Ind.*, vol. xxxvii, p. 257. [1909.]
1613. **Daubenton, L. J. M.** Tableau Méthodique des Minéraux. 8vo, Paris, 1788.
- Daubenton, L. J. M.**, see **Buffon, G. L. de.**
1614. **Daubeny, C. G. B.** A Description of Active and Extinct Volcanos. 8vo, London, 1826.
1615. **Daubrée, A.** Notice sur des dégagements de Gaz Inflammables, observés dans les Gîtes Métallifères. *Ann. Mines*, sér. 4, t. xiv, pp. 33-38. [1848.]
1616. ———. Notice sur le gisement de bitume, du lignite et du sel dans le terrain tertiaire des environs de Pechelbronn et de Lobsann (Bas-Rhin). *Ibid.*, t. xvi, pp. 287-322, pl. IV. [1849.]

1617. **Daubrée, A.** Sur la Présence de l'Arsenic et de l'Antimoine dans les Combustibles Minéraux, dans diverses Roches et dans l'Eau de la Mer. *Ann. Mines*, sér. 4, t. xix, pp. 669-683. [1851.]
1618. — Description géologique et minéralogique du département du Bas Rhin. 8vo, *Strasbourg*, 1852.
1619. — Carte géologique du département du Bas-Rhin. *Strasbourg*, 1852.
1620. — Sur le métamorphisme, et recherches expérimentales sur quelques uns des agens qui ont pu le produire. *Ann. Mines*, sér. 3, t. xii, pp. 289-326. [1857.]
1621. — Association de l'Arsenic aux Bitumes Minéraux. *Ann. Mines*, sér. 5, t. xvi, pp. 472-475. [1858.]
1622. — Études et expériences synthétiques sur le métamorphisme et sur la formation des roches cristallines. *Ibid.*, t. xvi, pp. 155-218, 393-476. [1859.]
1623. — Association du sel au pétrole dans le terrain tertiaire de Schwabwiler. *L'Institut*, p. 111. 1860.
1624. — Substances Minérales. Extraits des Rapports du Jury Internationale de l'Exposition Universelle de 1867. 8vo, *Paris*, 1867.
1625. — Couches à Pétrole des environs de Pechelbronn (Basse-Alsace), températures exceptionnellement élevées qui s'y manifestent. *Compt. Rend.*, t. cxvii, pp. 265-269. [1893.]
1626. **Daugherty, A. J.** Peruvian Petroleum. *Rep. Cons. U.S.*, vol. xii, pp. 128-130. [1893.]
- David, R.**, see **Prunier, L.**
1627. **David, T. W. E.** Note on the Origin of Kerosene Sha. *c. Proc. Linn. Soc. N.S. Wales*, ser. 2, vol. iv, pp. 483-500, pl. xviii. [1889.]
1628. **Davidov, P.** [Oil-deposits of Naruda-Jacobi, Guri.] 8vo, *Tiflis*, 1885.
1629. **Davidson, E.** Der Bergbau in Russland. *Zeit-schr. Berg-, Hütten- u. Salinenw.*, bd. xlv, pp. 90-130. [1897.]
1630. **Davies, D. C.** A Treatise on Earthy and other Minerals and Mining. 8vo, *London*, 1879.
1631. **Davies, E.** An Examination of some Samples of Pitch and Asphalt. *Trans. Brit. Pharm. Conf.* 1883, pp. 559-561.
1632. **Davies, E. H.** The Mineral Wealth of the Caucasus. *Min. Journ.*, vol. lxiii, pp. 398, 399, 416, 438. [1893.]
1633. **Davies, W.** Petroleum Tables; being some useful tables for ascertaining the Weights and Measures of Petroleum Cargoes, and a Table of Distances. *London*, 1911.
1634. **Davis, C. B.** On the Elimination and Quantitative Estimation of Water in Oils, Fats, and Waxes. *Journ. Amer. Chem. Soc.*, vol. xxiii, pp. 487, 488. [1901.]
1635. **Davis, G. E.** On the Valuation of Crude Naphthas of Commerce. *Journ. Soc. Chem. Ind.*, vol. iv, pp. 615-649. [1886.]
1636. **Davis, J. F.** The Chinese; a general description of the Empire of China and its inhabitants. 2 vols. 12mo, *London*, 1836.
1637. **Davis, W. M.** Friction and Lubrication. *Pittsburg, Pa.*, 1903.
1638. — Lubricating Oils and their properties: how to test them and detect adulterations. *Power*, vol. xxiv, pp. 139, 140, 240, 241, 302-304, 526. [1904.]
1639. **Davy, H.** On the State of Water and Aeriform Matter [Hydrocarbons, etc.] in Cavities found in certain Crystals. *Phil. Trans.*, 1822, pp. 367-376.
1640. **Dawkins, W. B.** [Crystals of Calcite and Pyrites round stalaclitic Bitumen of Castleton, Derbyshire.] *Proc. Lit. Phil. Soc. Manchester*, vol. xi, pp. 94, 95. [1872.]
1641. — On the Kerosene Shale of Mount Victoria, New South Wales. *Rep. Brit. Assoc.*, 1886, p. 643. [1887.]
1642. **Dawson, C.** On the Discovery of Natural Gas in East Sussex. *Quart. Journ. Geol. Soc.*, vol. liv, pp. 564-571. [1898.]
1643. — Excursion to Heathfield and Brightling [Sussex]. *Proc. Geol. Assoc.*, vol. xvii, pp. 171-175. [1901.]
1644. **Dawson, G. M.** Report on the Queen Charlotte Islands, 1878. *Ann. Rep. Geol. Surv. Canada* for 1878-79, report B, pp. 239, 3 maps. [1880.]
1645. — Notes to accompany a Geological Map of the Northern Portion of the Dominion of Canada, East of the Rocky Mountains. *Ibid.*, n.s., vol. ii, report R, pp. 62. [1887.]
1646. — On certain Borings in Manitoba and the North-west Territory. *Trans. Roy. Soc. Canada*, vol. iv, sect. 4, pp. 85-99. [1887.]
1647. — Summary Report(s) on the Operations of the Geological Survey for the year(s) 1894 (-1895). *Ann. Rep. Geol. Surv. Canada*, n.s., vols. vii-xi, reports A, 1896-1899.
1648. **Dawson, J. W.** Acadian Geology. An account of the Geological Structure and Mineral Resources of Nova Scotia. 8vo, *Edinburgh*, 1855.
1649. — On Spore-cases in Coals. *Canad. Nat.*, ser. 2, vol. v, pp. 369-377. [1871.]
1650. **Day, C.** The Diesel Oil Engine. *Rep. Brit. Assoc.*, 1911, pp. 486-488. [1912.]
1651. **Day, D. T.** On the Changes effected by Heat in the Constitution of Ethylene. *Amer. Chem. Journ.*, vol. viii, pp. 153-167. [1886.]
1652. — Mineral Resources of the United States 1895. *Ann. Rep. U.S. Geol. Surv.*, vol. xvii, pt. iii, pp. 5-21. [1896.]
1653. — A Suggestion as to the Origin of Pennsylvania Petroleum. *Proc. Amer. Phil. Soc.*, vol. xxxvii, pp. 112-115. [1897.]
1654. — Mineral Resources of the Antilles, Hawaii, and the Philippines. *Eng. Mag.*, vol. xvii, pp. 242-251. [1899.]
1655. — The Variation in the Character of Pennsylvania and Ohio Crude Oils. *1st Internat. Petrol. Congr.*, pp. 9, 10. [1900.]
1656. — Experiments on the Diffusion of Crude Petroleum through Fuller's Earth. *Science*, n.s., vol. xvii, pp. 1007, 1008. [1903.]
1657. — Light, the Great Civiliser. *Amer. Mag.*, 1906.
1658. — The International Petroleum Congress. *Eng. Min. Journ.*, vol. lxxxiv, pp. 781-784. [1907.]
1659. — The Production of Petroleum in 1907-8-9. *Min. Res. U.S.*, 1907-1909. [1908-1911.]
1660. — Map of Known Productive Oil and Gas Fields in the U.S. in 1908. *U.S. Geol. Surv.*, 1909.
1661. — Analyses of Crude Petroleum from Oklahoma and Kansas. *Bull. U.S. Geol. Surv.*, no. 381, pp. 22-31. [1909.]
1662. — The Petroleum Resources of the United States. *Ibid.*, no. 394, pp. 30-50. [1909.]
1663. — Natural Gas Resources of the United States. *Ibid.*, pp. 51-61. [1909.]
1664. — Asphalt and Bituminous Rock. *Min. Res. U.S.*, 1909. [1911.]
1665. — The Conditions of Accumulation of Petroleum in the Earth. *Trans. Amer. Inst. Min. Eng.*, vol. xii, pp. 219-224. [1911.]
1666. — The South's Oil Contribution. *Manuf. Rec.* Jan. 19, 1911.
1667. **Day, D. T.**, and **J. E. Gilpin.** The Changes in Crude Petroleum effected by Diffusion through Clay. *Journ. Ind. Eng. Chem.*, vol. i, pp. 449-455. [1909.]
1668. **Day, D. T., F. H. Oliphant,** and **F. W. Greer.** Petroleum in the Southern States. *Manuf. Record*, 1902.
1669. — — — — — Louisiana Oil and Gas. Tracing Occurrences in the State. *Ibid.*, 1910.
1670. **Day, W. C.** Investigation of Utah Gilsomite, a Variety of Asphalt. *Journ. Franklin Inst.*, vol. cxl, pp. 221-237. [1895.]
1671. — The Production of an Asphalt resembling Gilsomite by the Distillation of a Mixture of Fish and Wood. *Proc. Amer. Phil. Soc.*, vol. xxxvii, pp. 171-174, pl. x. [1898.]
1672. — The Laboratory Production of Asphalts from Animal and Vegetable Materials. *Amer. Chem. Journ.*, vol. xxi, pp. 478-499. [1899.]

1673. **Day, W. C.**, and **A. P. Bryant**. Investigation of a Bitumen from Park County, Montana. *Journ. Franklin Inst.*, vol. cxxxviii, pp. 149-152. [1894.]
1674. **Deane, C. T.** On the Oil Industry of California. *Bull. Calif. Petrol. Miners' Assoc.*, 1901.
1675. ——— The Burning of Crude Oil for Steam Purposes. *Petrol. Rev.*, vol. vi, pp. 385-397. [1902.]
1676. ——— The Position of the Californian Industry. *Ibid.*, vol. vii, p. 133. [1902.]
1677. ——— The Oil Fields of California. *Ibid.*, pp. 641-643. [1902.]
1678. ——— The Oil Industry of California from a Commercial Standpoint. 8vo, San Francisco, 1903.
1679. ——— The Oil Industry of California. *Eng. Min. Journ.*, vol. lxxvii, p. 86. [1904.]
1680. ——— The Petroleum Industry of California in 1904. *Min. Ind.*, vol. xiii, pp. 357-359. [1905.]
1681. **Dechen, H. v.** Die nutzbaren Mineralien und Gebirgsarten im Deutschen Reiche, nebst einer physiographischen und geognostischen Uebersicht des Gebietes. 8vo, Berlin, 1873.
1682. **Dechen, H. v.**, and **K. v. Oeynhausen**. Ueber den Bergtheer von Lobsanz. *Arch. Bergb.-Hütt.*, bd. xi, pp. 103-109. [1826.]
1683. **Deecke, W.** Geologischer Führer durch Campanien. 8vo, Berlin, 1901.
1684. **Deedmeyer, F.** Industrial Motor Uses (Canada). *U.S. Cons. Rep.*, no. 356, p. 53. [1910.]
- Deeley, R. M.**, see **Archbutt, L.**
1685. **Defays, J.**, and **H. Pittet**. Étude pratique sur les différents systèmes d'Éclairage (Gaz, acétylène, pétrole, alcool, électricité). *Encycl. Sci. Aide-mém. 8vo, Paris*, 1902.
1686. **Degerman, J.** Une ancienne source de Bitume en Alsace. *Mitth. Nat. Ges. Colmar, n.l.*, bd. ii, pp. 87-89. [1895.]
1687. **Degoussée, J.** Description des outils employés dans les travaux de sondage les plus récents. *Ann. Mines*, t. xiv, pp. 315-332. [1838.]
1688. ——— [Sur les sondages exécutés dans divers régions]. *Compt. Rend.*, t. xii, pp. 437-441. [1841.]
1689. ——— Description du levier romain, et d'un système de tiges en bois et en fer creux, combiné avec la coulisse d'Oeynhausen, pour les sondages de grandes profondeurs. *Ann. Mines*, t. xix, pp. 593-597. [1841.]
1690. **Del, J.** [Disinfecting Properties of Petroleum.] *Mosk. Med. Gaz.*, 1875, p. 533.
1691. **Deichman, A.** [On Igneous Phenomena in the Baku Province.] *Corn. Journ.*, 1828, t. ii, pp. 150-156.
1692. **De la Beche, H. T.** A Geological Manual. 8vo, London, 1831.
1693. **Delachanal, B.** Sur la composition de l'Asphalte ou Bitume de Judée. *Compt. Rend.*, t. xviii, pp. 491-494. [1833.]
1694. **Delacre, M.** Étude de la synthèse de la benzine par l'action du zinc-éthyle sur l'acetophenone. *Bruzelles*, 1891.
1695. **Delafield, R.** Report on the Survey of the Passes of the Mississippi. *Senate Doc.*, Congr. 21, sess. 1, vol. 1, pp. 7-14. [1829.]
- Delaforest, —**, see **Laforest, de**.
1696. **Delahaye, H.** Huiles Minérales, Pétroles, Benzols, Brais, Paraffines, Vaseline, Ozokerite. 8vo, Paris, 1911.
1697. **Delahaye, N. B.** Sur les schistes de Muse [Saône-et-Loire]. *Bull. Soc. Géol. France*, sér. 2, t. v, pp. 304-308. [1818.]
1698. ——— Quelques réflexions au sujet d'une lettre de M. l'Abbé Landriot [sur les fossiles des schistes de Muse]. *Ibid.*, sér. 2, t. vi, pp. 374-377. [1819.]
1699. ——— Faits et observations pour servir à l'histoire des schistes bitumineux. *Rev. Sci. Indust.*, t. xxxviii, pp. 1-17, 49-63, 97-100, 161-174, 225-232, 321-329, 337-352, 440-447. [1850.]
1700. **De la Loyère, —**, and — **Muntz**. Sur la production d'huiles sulfurées douées de propriétés insecticides. *Compt. Rend.*, t. lxxxvi, pp. 1185-1187. [1878.]
- Delaméthérie, J. C.**, see **Méthérie, J. C. de la**.
1701. **Delannoy, F.** Découverte de Terrains Pétrolières dans la Limagne d'Auvergne par MM. P. Dubreuil et J. de Clercy. *Gén. Civ.*, t. xxii, pp. 102-104. [1892.]
1702. **Delano, W. H.** L'Asphalte et ses applications, dalazes et enduits. *Technol.*, t. xxxvii, pp. 212-214. [1876.]
1703. ——— On the Use of Asphalt and Mineral Bitumen in Engineering. *Proc. Inst. Civ. Eng.*, vol. ix, pp. 249-307. [1880.]
1704. ——— Twenty Years' Practical Experience of Natural Asphalt and Mineral Bitumen. 8vo, London and New York, 1893.
1705. ——— Recent Developments of the Asphalt Industry. *Proc. Inst. Civ. Eng.*, vol. ciii, pp. 253-268. [1903.]
1706. **De la Rue, W.** Distillation des naphtes et des goudrons. *Technol.*, t. xx, p. 352. [1859.]
1707. **De la Rue, W.**, and **H. Müller**. Chemical Examinations of Burmese Naphtha, or Rangoon Tar. *Proc. Roy. Soc.*, vol. viii, pp. 221-228. [1857.]
1708. **Delbos, J.**, and **J. Köchlin-Schlumberger**. Description géologique et minéralogique du département du Haut Rhin. 2 Tt. 8vo, Mulhouse, 1867.
1709. **Delesse, A.** Recherches de l'Azote et des Matières organiques dans l'Ecorce Terrestre. *Ann. Mines*, sér. 5, t. xviii, pp. 151-324. [1860.]
1710. ——— De l'Azote et des Matières organiques dans l'Ecorce Terrestre. 8vo, Paris, 1861.
- Delisle, J. B. L. de R.**, see **Romé Delisle, J. B. L. de**.
1711. **Delius, G. H.** Ueber ein Steinöl in Bayern. *Chem. Ann.*, 1784, bd. ii, pp. 436-441.
1712. **Del Mar, A.** Cementing-Off Water from Oil- Wells. *Eng. Min. Journ.*, vol. xc, p. 250. [1910.]
1713. **Del Proposta, C.**, **A. Lecointe**, and **K. Boklewsky**. Propulsion des Navires par Machines Irréversibles. *Bull. Soc. Belg. d'Electr.*, t. xxiii, pp. 281-353. [1906.]
- Demarçay, E.**, see **Cahours, A.**
1714. **Demarchi, L.** I prodotti minerali della provincia di Roma. 8vo, Rome, 1832.
1715. ——— Distretto di Roma. *Rel. Serv. Min.*, 1880, pp. 251-273. [1883.]
1716. **Demare, L.** Les Gisements Pétrolières de la Roumanie. *Ann. Mines Belg.*, t. xiii, pp. 401-456, 689-777. [1908.]
1717. **Demare, —**, and — **Freson**. Étude sur les gisements de pétrole. 8vo, Brussels, 1905.
1718. **Demel, W.** Ueber den Dopplert von Aussee. *Monatsh. Chem.*, bd. iii, pp. 765-769. [1882.]
1719. **Démidoff, A. de**. Voyage dans la Russie Méridionale et la Crimée, par la Hongrie, la Valachie et la Moldavie, exécuté en 1837. 4 Tt. 8vo; Atlas, 2 Tt. fo, Paris, 1840-1842.
1720. **Demski, H.** and **T. Moravski**. Zur Bestimmung von Harzölen in Mineralölen. *Polyt. Journ.*, bd. cclviii, pp. 82-87. [1885.]
1721. **Denayrouze, L.** Lampe à incandescence par la vapeur d'hydrocarbure fonctionnant à basse pression. *Journ. Pét.*, t. vii, pp. 51-55. [1907.]
1722. ——— Sur l'emploi des hydrocarbures lourds pour l'éclairage. *Ibid.*, t. viii, pp. 41, 42. [1908.]
1723. **Denby, C.** Natural Gas in China. *Rep. Cons. U.S.*, vol. xxvi, pp. 200, 201. [1888.]
1724. **Deneys et Cie.** Notices sur le Commerce et sur l'Industrie de Naphte de Bakou en 1890. Fo, Baku, 1891.
- Denis, J.**, see **Conradus, D.**
1725. **Denis, T. C.** Western Oil, Gas, and Coalfields. *Summary Rep. Canada Geol. Surv.* for 1906, pp. 164-169. [1907.]
1726. ——— Petroleum and Natural Gas. *Ann. Rep. Dept. Mines, Canada*, 1906-1909. [1907-1910.]
1727. **Dennis, G.** Report for the years 1882-1886 on the Trade of Smyrna. *Dipl. Cons. Rep.*, ann. ser., nos. 67, 175. [1886, 1887.]
1728. **Dennstedt, M.** Die Feuegcfahr im Hause. *Hamburg*, 1902.

1729. **Dennstedt, M.** Verhütung der Explosion von Petroleumlampen. *Chem.-Zeit.*, bd. xxx, pp. 541, 542. [1906.]
- Dennstedt, M.**, see **Heusler, F.**
1730. **Denny, H. S.** The Oil Excitement in Mexico. *Mining Journ.*, vol. lxxxix, pp. 711-714. [1910.]
1731. **Denton, W.** On a Mineral, resembling Albertite, from Colorado [Utah]. *Proc. Boston Soc. Nat. Hist.*, vol. x, pp. 303, 306. [1866.]
1732. — On an Asphaltic Bed near Los Angeles, Cal., and its contained fossils. *Ibid.*, vol. xviii, pp. 185, 186. [1876.]
1733. **Denza, F.** La fontana ardente di Casale [Vicenza]. *Ann. Sci. Ind. Milan*, vol. xxviii. [1892.]
1734. **Deprez, M.** Sur une machine destinée à l'étude des lois du frottement et du pouvoir lubrifiant des corps gras. *Compt. Rend. Assoc. Franç.*, sess. 5, pp. 118-121. [1876.]
1735. **Derby, G. M.** Annual Report of the Inspector of Asphalts and Cements. *Rep. Eng. Dept. D. C.*, 1893. [1894.]
1736. **Derby, O. A.** The Sedimentary Belt of the Coast of Brazil. *Journ. Geol.*, vol. xv, pp. 218-237. [1907.]
1737. **Dern, J.** The Mining and Mineral Resources of Utah. *Mines and Minerals*, vol. xxvii, pp. 250-252. [1907.]
1738. **Derville, —**, and — **Gnermonprez.** Le Papillome des Rafineries de Pétrole. *Ann. Hygiène Publ.*, t. xxiv, p. 560. [1890.]
1739. **Desbief, P.** Schistes bitumineux des environs d'Autun. *Ann. Mines*, sér. 5, t. xiv, pp. 44, 45. [1858.]
1740. — Des gisements d'asphalte, de bitume, de pétrole, et de naphthe. *Bull. Soc. Industr. Min.*, t. v, pp. 399-421. [1866.]
1741. **Deschivov, M.**, and **Kh. N. Valberg.** [Portable Gas Apparatus.] *Gorn. Journ.*, 1869, t. 3, pp. 297-301.
1742. **Deshayes, L. A. L.** Savons au pétrole et à la gazoline et leur procédé de fabrication. *Rev. Prod. Chim.*, t. viii, p. 118. [1905.]
1743. **Desor, E.** Observations sur les Bords de Biene dans le Canton de Vaud. *Bull. Soc. Sci. Nat. Neuchâtel*, t. i, pp. 77-78. [1844.]
1744. — Les Plissements du Val-de-Travers. *Bull. Soc. Sci. Nat. Neuchâtel*, t. liii, pp. 265-272. [1893.]
1745. — Du gisement et de l'analyse des roches asphaltiques de la mine d'asphalte de Saint Aubin (Canton de Neuchâtel). *Ibid.*, t. iv, pp. 358-394. [1858.]
1746. — [L'Asphalte du Val de Travers.] *Ibid.*, t. vii, pp. 547-550. [1867.]
1747. — Sur l'origine de l'asphalte dans le Val de Travers. *Verh. schweiz. nat. Ges.*, bd. liii, pp. 65, 66. [1868.]
1748. — L'Asphalte du Val de Travers. *Almanach de la République, Neuchâtel*, 1869.
1749. — [L'Asphalte à Dent de Vaulion et à Lelex.] *Bull. Soc. Sci. Nat. Neuchâtel*, t. x, p. 156. [1875.]
- Dessila, V.** see **Ficsinesco, T.**
1750. **Désvaux, N. A.** Note sur la substance minérale Naphthéine, trouvée le département de Maine et Loire. *Mém. Soc. Agric. Angers*, t. ii, pp. 139, 140. [1834.]
- Desvignes, —**, see **Calvet, —**
1751. **Deutsch, H.** Le Pétrole et ses applications. 8vo, Paris, 1894.
1752. — The Application of Petroleum to Aerial Navigation. *1st Internat. Petrol. Congr.*, pp. 37, 38. [1900.]
1753. **Devey, G. P.** Report on the Trade of Erzeroum for the years 1885, 1886. *Dipl. Cons. Rep.*, ann. ser., nos. 30, 212. [1886, 1887.]
1754. — Report for the year 1886 on the Trade of the Vilayet of Kharput. *Ibid.*, no. 225. [1887.]
1755. — Report for the year 1896 on the Trade of Jeddah. *Ibid.*, no. 2006. [1897.]
1756. **Devalque, G.** Sur la hatchettite de Seraing [Belge]. *Ann. Soc. Géol. Belg.*, t. x, pp. lxxi-lxxiv. [1883.]
1757. **Dewar, J.** The American Oil and Gas Fields. *Journ. Soc. Arts*, vol. xxxiii, pp. 771-783. [1885.]
1758. **Diancourt, —** Die Oelindustrie in der Lüneburger Heide. *Samm. Berg.-Hütt. Abhandl.*, h. 26. Pp. 22. [1908.]
1759. **Dickson, J.** Report for the years 1887, 1888 on the Trade of Damascus. *Dipl. Cons. Rep.*, ann. ser., nos. 417, 538. [1888, 1889.]
1760. **Dickson, S. S.** Report on the Trade of Columbia for 1903. *Dipl. Cons. Rep.*, ann. ser., no. 3111. [1901.]
1761. **Didier, M.** L'Industrie du Pétrole en Roumanie. *Journ. Pét.*, t. xi, p. 132. [1911.]
1762. — Un événement pétrolier en Roumanie. *Ibid.*, p. 183. [1911.]
- Didkovski, —**, see **Kordynkov, —**
- Diederichs, H.** see **Carpenter, R. C.**
1763. **Diesel, R.** Theorie und Konstruktion eines rationellen Wärmemotors zum Ersatz der Dampfmaschine, u.s.w. Berlin, 1893.
1764. — Diesels rationeller Wärmemotor. *Zeitschr. Ver. deutsch. Ing.*, bd. xii, pp. 785-791, 817-821. [1897.]
1765. — Mitteilungen über den Dieselschen Wärmemotor. *Ibid.*, bd. xliii, pp. 36-42, 128-130. [1899.]
1766. — Der heutige Stand der Wärmekraftmaschinen und die Frage der flüssigen Brennstoffe, unter besonderer Berücksichtigung des Diesel-Motors. *Ibid.*, bd. xlvi, pp. 1366-1375. [1903.]
1767. — Ueberblick über den hentigen Stand des Dieselmotorenbaues und die Versorgung mit flüssigen Brennstoffen. *Zeitschr. Ver. deutsch. Ing.*, bd. lv, pp. 1345-1353. [1911.]
1768. — Die Motorschiffahrt in den Kolonien. *Techn. Wirtsch.*, bd. v, pp. 24-37. [1912.]
1769. **Dietrich, E.** Die Asphalt-Strassen. 8vo, Berlin, 1882.
1770. — Versuche mit Stampfasphalt. *Asphalt-Teerind. Zeit.*, bd. v, p. 417. [1905.]
1771. — Abwehrmittel gegen die Schlüpfrigkeit der Asphaltbeläge. *Asphalt-Teerind.-Zeit.*, bd. xi, pp. 279, 293, 300. [1911.]
1772. **Dietrich, P. F. de.** Description des gites de minéral et bouches à feu de la France. 4 Tt. 4to, Paris and Strasbourg, 1786-1799.
1773. **Dietrichs, J.** Practical Treatise on Friction, Lubrication, Fats and Oils. [1907.]
- Dieudonné, C.**, see **Sainte Claire Deville, H. E.**
1774. **Dieulafait, L.** L'origine et la formation des minéraux métallifères. *Rer. Sci.*, t. xxxi, pp. 609-618. [1883.]
1775. **Dijk, P. van.** Geologische Beschrijving der Residentie Djokdjakarta. *Jaarb. Mijnw. Ned. O.-Ind.*, jg. i, dl. 1, pp. 149-192, map. [1872.]
1776. — Steenkolen in het Samarangsche. *Ibid.*, jg. ii, dl. 2, pp. 164-174. [1873.]
1777. — Onderzoek naar het voorkomen van Aardolie in de nabigheid van Poerwodadi, assistent-residentie Grobogan. *Ibid.*, jg. xii, pp. 359-369, map and sections. [1883.]
1778. — Over de geologie van het noordelijke, niet vulkanische gedeelte van de residentie Soerabaja. *Ibid.*, jg. xiii, Wetens., pp. 5-76, map. [1884.]
- Dijk, P. v.**, see **Ermaling, J. P.**
1779. **Dinsmore, C. A.** The Toyah Oil Field, Texas. *Mining World*, vol. xxxii, p. 1118; vol. xxxiii, p. 176. [1909, 1910.]
- Dislere, —**, see **Evrard, —**
1780. **Dittmar, P. N.** [On the Conversion of Kerosene into a solid jelly for convenience of transport, and its reconversion to a liquid form.] *Zap. Imp. Russk. Tekhn. Obsch.*, g. xvi, otd. 1, pp. 1-7. [1882.]
1781. **Dittel, —** [Sketch of a Journey to the East in 1842-45.] *Bibl. Tscheniya*, 1849, t. 95.
1782. **Dittmar, K. v.** Reisen und Aufenthalt in Kamtschatka in den Jahren 1851-1855. *Beitr. Russ. Reichs.*, bd. vii, pp. x, 867. Maps. [1890.]
1783. **Dittmar, W.** The Endiometric Analysis of Mixtures of Paraffines. *Chem. News*, vol. xxxvii, p. 226. [1878.]

1784. **Diama, A.** [Journey through the Caucasus.]
1785. **Divers, E., and T. Nakamura.** On an Apparently New Hydrocarbon from Distilled Japanese Petroleum. *Journ. Chem. Soc.*, vol. xvii, pp. 924-926. [1885.]
1786. **Dixon, H. B., and W. A. Bone.** An Analysis of the Natural Gas at Heathfield, Sussex. *Proc. Chem. Soc.*, vol. xix, pp. 65-66. [1903.]
1787. **Dixon, H. B., and H. F. Coward.** The Ignition-Temperatures of Gases. *Journ. Chem. Soc.*, vol. xcv, pp. 514-513. [1909.]
1788. **Dixon, W. A.** Some Considerations in regard to the Formation of Coal and Carbonaceous Minerals. *Rep. Austral. Assoc.*, vol. i, pp. 125-137. [1887.]
1789. **Dodd, J.** Formosa. *Scott. Geogr. Mag.*, vol. xi, pp. 553-570. [1895.]
1790. **Dodds, R.** Note on a Natural Paraffin found in the Ladysmith Pit, Whitehaven Collieries. *Trans. Inst. Min. Eng.*, vol. xxix, pp. 284, 285. [1905.]
1791. **Dodge, J. R.** Coal-oil in West Virginia. *Rep. Comm. Agric. W. Virginia*, 1863, p. 72.
1792. **Döbner, O. G.** Ueber Chinolinbasen im Braunkohlentheer. *Ber. deutsch. chem. Ges.*, bd. xxviii, pp. 106, 107. [1895.]
1793. **Doeltz, F. O.** Ueber einen Petroleumkoks für metallurgische Laboratoriumszwecke. *Chem. Zeit.*, bd. xxx, p. 585. [1906.]
1794. **Dolinski, L.** [Mining Statistics, S.W. Russia.] *Zap. Odessk. Old. Imp. Russk. Tekhn. Obsch.*, 1887, pp. 1-49; 1889, pp. 1-63; 1890, pp. 1-31.
1795. **Dollfus, A.** Sur l'emploi des graisses d'asphalte de Pechelbronn. *Bull. Soc. Industr. Mulh.*, t. xxxii, pp. 66-72. [1861.]
1796. **Dollfus, G., and E. Dollfus.** Rapport sur un mémoire traitant de l'inflammabilité spontanée des déchets gras et de l'inflammabilité relative des différentes huiles employées au graissage des machines, par M. J. J. Coleman. *Ibid.*, t. xvi, pp. 108-112. [1876.]
1797. **Dollfus, G., and S. Meunier.** Variété remarquable de Cire Minérale. *Compt. Rend.*, t. cv, pp. 823, 824. [1887.]
1798. **Dolomieu, D. G. S. T. de.** Voyage aux fles de Lipari, fait en 1781. 8vo, Paris, 1783.
1799. — Sur les Volcans éteints du Val di Noto, en Sicile. *Journ. Phys.*, t. xxv, pp. 191-205. [1784.]
1800. **Domenech, M. Y.** Porto Rico, her Mineral Resources. *Mines and Minerals*, vol. xix, pp. 529-532, map. [1899.]
1801. **Dominian, L.** Petroleum in Turkey. *Eng. Min. Journ.*, vol. lxxviii, pp. 184, 185. [1905.]
1802. **Dommer, F.** L'Incandescence par le Gaz et le Pétrole, l'Acétylène et ses applications. (Biblioth. Actual. Industr.) 8vo, Paris, 1896.
1803. **Domojirov, A.** [Liquid Fuel for Ships.] *Morsk. Sborn.*, 1884, no. 1, pp. 127-155.
1804. **Dompe, L.** Distretto di Caltanissetta. *Rel. Serv. Min.*, 1900, pp. 31-102; 1901, pp. 39-123; 1902, pp. 29-120, pt. ii. [1901-1903.]
1805. **Donath, E.** Notiz zur Bestimmung des Paraffins in den Stearinsäure-(Milky) Kerzen. *Polyt. Journ.*, bd. cvviii, pp. 305, 306. [1873.]
1806. — Die Prüfung der Schmiermaterialien. *Leoben*, 1879.
1807. — Zur "Festmachung" und "Verseifung" des Erdöles. *Chem.-Zeit.*, bd. xvi, pp. 590-591. [1892.]
1808. — Zur Prüfung von Ceresin auf Colophonium. *Chem. Rec. Fett-Harz-Ind.*, bd. x, pp. 72, 73. [1903.]
1809. — Zur Reinigung der Abwässer der Mineral-Ölraffinerien. *Oesterr. Chem.-Zeit.*, bd. ix, pp. 5-8. [1906.]
1810. **Donath, E., and B. M. Margosches.** Zur Unterscheidung der "Asphalte." *Chem. Ind.*, bd. xxvii, pp. 220-226. [1904.]
1811. — Bemerkungen zum Nachweise von Verfälschungen im Naturasphalt. *Oesterr. Chem.-Zeit.*, bd. viii, pp. 175-177. [1905.]
1812. **Donath, E., and R. Strasser.** Notiz über das Stearinpech. *Oesterr. Chem.-Zeit.*, bd. xvii, p. 1788; bd. xviii, p. 182. [1893, 1894.]
1813. **Donkin, B. jun.** Textbook on Gas, Oil, and Air Engines; or Internal Combustion Motors without Boiler. 8vo, London, 1894.
1814. **Donnan, F. G., and H. E. Potts.** Ueber die Emulgierung von Kohlenwasserstoffölen durch wässrige Lösungen fettsaurer Salze. *Zeitschr. Chem. Ind. Koll.*, bd. vii, pp. 208-214. [1910.]
1815. **Doolittle, O. S.** The Torsion Viscometer. *Journ. Amer. Chem. Soc.*, vol. xv, pp. 173-177. [1893.]
1816. **Dopp, F.** Ueber Petroleummotoren mit besonderer Berücksichtigung der neuen Motoren von Diesel und von Dopp. *Sitz. Ver. Beförd. Gewerbf.*, 1899, pp. 140-164.
1817. **Doremus, R. O.** New System of Deodorizing Petroleum. *Sci. Amer.*, ser. 2, vol. xiii, p. 383. [1865.]
1818. **Doroschenko, A. S.** [Aromatic Hydrocarbons in Caucasus Petroleum.] *Jurn. Russk. Fiz. Khim. Obsch.*, t. xvii, old. i, pp. 285-290. [1885.]
1819. — [Qualities of Kerosene produced in the Baku Refineries, and need of modification of the system of separation.] *Trudi Bak. Old. Imp. Russk. Tekhn. Obsch.*, 1889-91, pp. 117-138. [1892.]
1820. — [Three Analyses of Petroleum from the Taman Peninsula.] *Ibid.*, 1894, Jan.-Feb., p. 51.
1821. **Doroschenko, A. S., and E. H. Chais.** [Report of the Committee for determination of a type of heavy Kerosene, and investigating the means of increasing the proportional yield of illuminating Oil.] *Ibid.*, 1889-91, pp. 139-144. [1892.]
1822. **Dorp, W. A. v.** Ueber eine neue Synthese des Anthracens. *Ber. deutsch. chem. Ges.*, bd. v, pp. 1070-1072. [1872.]
1823. **Doss, B.** Ueber Ansammungen von Erdgas in Untergrund Rigas. *Korr.-bl. Naturf. Ver. Riga*, bd. ii, pp. 47-53. [1908.]
1824. — Ueber das Naturgas-bohrloch auf dem Gute der Gebrüder Melnikow im Kreise Nowo-Uzensk, Gouvernement Samara. *Ann. Géol. Min. Russ.*, t. x, pp. 212-220. [1908.]
1825. **Douglas, P.** The Kansas Oil Fields. The position of the Standard Oil Company. Pipe Line Regulations and Laws. *Petrol World*, vol. iii, pp. 105, 204, 205. [1906.]
1826. **Douglas, R.** Wyoming; its Petroleum and Mineral Resources. *Petroleum*, vol. i, pp. 1127-1130, 1184-1186, pl. [1901.]
1827. **Doumerc, J., see Bianconi, F.**
1827. **[Dournay, F.]** Notice sur les Produits bitumineux dex mines de Lobmann. *Strasbourg*, 1838.
1828. **Douxami, H.** Étude sur la Vallée du Rhône aux environs de Bellegarde. *Bull. Carte Géol. France*, no. 81, pp. 21, or t. xii, pp. 123-143. [1901.]
1829. **Douzard, E.** An Acoustical Method for the Determination of the Melting Point of Fats and Waxes. *Chem. News*, vol. lxxix, pp. 150, 151. [1899.]
1830. **Dow, A. W.** Annual Reports of the Inspector of Asphalt and Cements, 1894-1905. *Rep. Eng. Dep. D. C.*, 1895-1906.
1831. — The History of the Asphalt Industry to 1901, inclusive. *Min. Ind.*, vol. x, pp. 51-67. [1902.]
1832. — The Testing of Bitumens for Paving Purposes. *Proc. Amer. Soc. Test. Mat.*, vol. iii, pp. 349-373. [1903.]
1833. — Relation between some Physical Properties of Bitumens and Oils. *Ibid.*, vol. vi, pp. 497-508. [1906.]
1834. **Dow, N.** The Gas Wells of Pennsylvania. *Sci. Amer.*, ser. 2, vol. xxv, p. 671. [1871.]
- **Dowglewitsch, N.** see Ipatiew, W. N.
1835. **Doyle, P. A.** Contribution to Burman Mineralogy. 16mo, Calcutta, 1879.
1836. — Petroleum; its History, Origin and Use, with reference to its advantages and perils as an Illuminator. 8vo, Brisbane. [1880.]



1837. **Draghiciu, M. M.** Erläuterungen zur geologischen Uebersichtskarte des Königreiches Rumänien. *Jahrb. k.-k. geol. Reichs.*, bd. xl, pp. 399-420, pl. iii (map, 1:800,000). [1890.]
1838. **Dragu, T.** Description des installations et des appareils en usage aux chemins de fer de l'Etat Roumain pour l'emploi des résidus de pétrole en chauffage des locomotives. 8vo, *Bucharest*, 1907.
1839. **Drake, D. A.** Systematic Treatise, Historical, Etiological, and Practical, on the Principal Diseases of the Interior Valley of North America, as they appear in the Caucasian, African, Indian and Esquimaux varieties of its population. 8vo, *Cincinnati*, 1850.
1840. **Draper, H. N.** Petroleum; its Importance, its History, Boring, Refining. *Quart. Journ. Sci.*, vol. ii, pp. 49-59. [1865.]
1841. ——— On the Behaviour of Castor Oil with Petroleum and Paraffin Oils. *Chem. News*, vol. xxii, pp. 162, 163. [1870.]
1842. **Drazoovic-Jelic, G.** Analisi dei cinque principali Asfalti Dalmati. *Progr. Oberrealschule in Spalato*, 1874.
1843. **Dreger, J.** Notiz über ein Petroleum-Vorkommen in Süddeistermark. *Verh. k.-k. geol. Reichs.*, 1893, p. 287.
- Dreher, E.**, see **Otto, R.**
1844. **Drescher, R.** Petroleumgas. *Deutsch. Ind. Zeit.*, 1868, pp. 437, 438.
1845. **Dreyfus, J.** Note on the Iodine value of Paraffin Oil. *Journ. Amer. Leather Chem. Assoc.*, vol. iii, p. 394. [1908.]
1846. **Droux, L.** Les Produits chimiques et la Fabrication des Savons. Ed. ii. 8vo, *Paris*, 1887.
1847. **Drugman, J.** The Oxidation of Hydrocarbons at Low Temperatures. *Journ. Chem. Soc.*, vol. lxxxix, pp. 939-945. [1906.]
1848. **Dubbel, H.** Kraftmaschinen auf der Bayerischen Landesausstellung in Nürnberg. *Zeitschr. Ver. deutsch. Ing.*, bd. 1, pp. 1567-1574, 1788-1796. [1906.]
1849. **Dubinevitch, V.** [Analysis of the Mud of the Enikale Mud-volcano (Kertch).] *Varsavsk. Univ. Izv.*, 1885, no. 6, pp. 1-6.
1850. ——— [Analysis of the Oil-waters of the Il valley, Kuban.] *Ibid.*, 1886, no. 1, pp. 1-9. [1886.]
1851. **Du Blé, C. L. L.** De Bitumine. 8vo, *Leyden*, 1761.
1852. **Dubois, G.** Die Bitumen von Barbados. *Zeitschr. prakt. Geol.*, bd. vii, p. 397. [1899.]
1853. **Du Bois, J. T.** [German Petroleum.] *U.S. Cons. Rep.*, vol. iii, p. 469. [1881.]
1854. **Dubois-Aymé, —.** Notice sur le Mont Braisier. *Ann. Chim. Phys.*, sér. 2, t. xviii, pp. 158-169. [1821.]
1855. **Dubois de Montpéroux, F.** Voyage autour du Caucase, chez les Tcherkesses et les Abkhazes, en Colchide, Géorgie, Arménie et la Crimée. 3 Tt. 8vo, *Paris*, 1846.
1856. **Duchemin, R.** Pétrole et Alcool—Réponse à M. Guisein. *Journ. Pét.*, t. viii, pp. 211-213. [1908.]
1857. **Duchesne, L.** Étude d'Hygiène. Des Liquides employés dans l'Éclairage artificiel. 4to, *Paris*, 1864.
1858. **Ducker, D. von.** [Asphalt in Westphalia.] *Verh. nat. Ver. preuss. Rheinl.*, jg. xxxvii, Corr.-Blatt, pp. 83-88. [1880.]
1859. ——— Petroleum und Asphalt in Deutschland. *Bückeburg*, 1880.
1860. **Ducloux, E. H.** Asfaltos de Jujuy. *An. Soc. Ci. Argent.*, t. iv, pp. 241-246. [1903.]
1861. **Dudeu, H.** Some Notes on the Black Slate or Genesee Shale of New Albany, Indiana. *Ann. Rep. Geol. Indiana*, vol. xxi, pp. 108-118. [1897.]
1862. **Dudley, C. B.** Fuel Oil. *Journ. Franklin Inst.*, vol. cxxvi, pp. 81-95, 2 pls. [1888.]
1863. **Duenas, E. J.**, and **J. J. Bravo.** Recursion minerales de Jajya y Hinancay o. *Bol. Ing. Min. Peru*, no. 35. Pp. 121; 10 pls. [1906.]
1864. **Duenas, E. J.**, and **J. J. Bravo.** Aspecto Minero del Departamento del Guazo. *Bol. Ing. Min. Peru*, no. 53. Pp. vii, 104, pl. and 2 maps. [1907.]
1865. **Dufais, F. F.** Petroleum Wells in France. *U.S. Cons. Rep.*, vol. xx, pp. 375-377. [1886.]
1866. **Duff, A.** Account of the Nat Mee, or the Spirit Fire, a burning Hillcock in the Province of Pegu. *Journ. As. Soc. Beng.*, vol. xxx, pp. 309-313. [1861.]
1867. **Dufouret, E.** De Dax à Castel-Sarrazin. Excursion archéologique, historique et géologique. 8vo, *Dax*, 1883.
1868. **Dufrenoy P. A.** Traité de Minéralogie. 4 Tt. 8vo, *Paris*, 1844, 1845.
1869. **Dulk, G.** Asphalt als Brücken-Belag. *Deutsch. Bauzeit.*, bd. ii, p. 39. [1868.]
1870. **Dullo, —.** Die Reinigung des Petroleums mittelst Chlorkalk. *Deutsch. Ill. Geuerbesetz.*, bd. xxx, p. 231. [1865.]
- Doligea, S.**, see **Edeleanu, L.**
1871. **Dumas, E.** Carte géologique du Département du Gard. Arrondissement d'Alais, et Arrondissement d'Uzès. *Paris*, 1874.
1872. **Dumas, J. B.** Traité de Chimie appliquée aux arts. 8 Tt. *Paris*, 1828-1846.
1873. ——— Note sur une variété de sel gemme qui dérépète au contact de l'eau [Wieliczka.] *Ann. Chim. Phys.*, sér. 2, t. xliii, pp. 316-320. [1830.]
1874. ——— Note sur les diverses combinaisons de l'hydrogène carboné. *Ibid.*, t. xlviii, pp. 430-432. [1831.]
1875. ——— Recherches sur les Combinaisons de l'Hydrogène et du Carbone. *Ibid.*, sér. 2, t. i. pp. 182-197. [1832.]
1876. ——— Mémoire sur les substances végétales qui se rapprochent du camphre, et sur quelques huiles essentielles. *Ibid.*, pp. 225-240. [1832.]
1877. ——— Rapport sur un Mémoire de M. Selligie, relatif à de nouveaux procédés de fabrication du gaz pour l'éclairage. *Compt. Rend.*, t. x, pp. 861-865. [1840.]
1878. ——— Remarques sur les carbures d'hydrogène produits dans l'action d'un acide sur la fonte et l'acier. *Ibid.*, t. lxxviii, pp. 1514, 1515. [1874.]
1879. **Dumble, E. T.** The Nacogdoches Oil Field. *Geol. Sci. Bull. Texas*, vol. 1. 1888.
1880. ——— Introductory. *Second Ann. Rep. Geol. Surv. Texas*. [1891.]
1881. ——— Note on the Occurrence of Grahamite in Texas. *Trans. Amer. Inst. Min. Eng.*, vol. xxi, pp. 601-605. [1894.]
1882. ——— Some Texas Oil Horizons. *Trans. Texas Acad. Sci.*, vol. ii, pp. 87-92. [1897.]
1883. ——— Physical Geography, Geology, and Resources of Texas. In "A Comparative History of Texas," 1898.
1884. ——— Geology of the Beaumont Oil-fields (Texas). *Houston, Texas*. [1901.]
1885. ——— Texas Iron Ore, Lignites, and Oil. *Coll. Guard.*, vol. lxxxiii, p. 132. [1901.]
1886. ——— Age of Petroleum-Deposits, Saratoga (Texas). *Science*, n.s., vol. xliii, pp. 510, 511. [1906.]
1887. **Dumitriu, V.** Analize executate in laboratorul de Chimie. *An. Inst. Geol. Roman.*, vol. iii, pp. 556-564. [1910.]
- Dumont, E. F.**, see **Frézon-Dumont, E.**
1888. **Dundas, —.** Reports for the years 1902-1904 on the Trade of Roumania. *Dipl. Cons. Rep.*, ann. ser., nos. 2990, 3204, and 3432. [1903-1905.]
1889. **Dundonald, Earl of.** Brief Extracts on the Use, Properties, and Products of the Bitumen and Petroleum of Trinidad. 4to, *London*, 1857.
- Dungan, A. S.**, see **Crum, A. R.**
1890. **Dunikowski, E. H. v.** Die zukünftigen Petroleumgruben Galiziens. *Naphta*, jg. xii, pp. 151-153, 171-174, 191-194, 231-234. [1905.]
1891. ——— Le Pétrole dans l'Afrique du Nord. *Journ. Pét.*, t. ix, pp. 225-229. [1909.]

1892. **Dunikowski, E. H. v.** Le Pétrole dans l'Algérie. *Journ. Petr.*, t. xi, pp. 117-120. [1911.]  
**Dunikowski, E. H. v.**, see **Walter, H.**
1893. **Dunlop, R.** Oil-shale Deposits at Orepuki. *Rep. Dep. Mines New Zealand*, 1900, C 3, pp. 52-54.
1894. **Dunn, K. G.** Size of Stacks with Fuel Oil. *Journ. Amer. Soc. Mech. Eng.*, vol. xxxiii, p. 886. [1911.]  
**Dunn, O. C.**, see **Mabery, C. F.**
1895. **Dunstan, W. R.** Trinidad Petroleum. Report on a second Consignment of Petroleum from the Mayaro-Guayaquayare District, Trinidad. Pp. 4, 10. *Port-of-Spain*, 1905.
1896. **Dupaigne, A.** Le Pétrole, son histoire, sa nature, ses usages et ses dangers. 18mo, Paris, 1872.
1897. **Duperrey, L. I.** Collections Géologiques [faites sur la corvette *La Coquille*]. *Ann. Sci. Nat.*, t. vi. [1825.]
1898. **Durand, W. F.** Motor Boats. *Marine Engineering*, vol. x, pp. 278-280, 319-321, 385-388, 415-417, 456, 457, 490-494; vol. xi, pp. 21-23, 68-70, 93-96, 148-150, 180-182, 236, 237, 277-280, 308-311, 366, 367, 403-405. [1905, 1906.]
1899. **Durin, E.** Sur les hydrocarbures des tourbes. *Compt. Rend.*, t. xxvi, pp. 652, 653. [1883.]
1900. ——— [The Extraction of Paraffin and Heavy Oil from Petroleum-Residues.] *Mon. Prod. Chim.*, 1883, p. 250.
1901. **Durini, G. N.** Relazione sul solfo e sul bitumine d'Abruzzo Citeriore. *Atti R. Acc. Sci. Napoli*, vol. ii, pp. 39-50. [1825.]
1902. **Durival, M.** Description de la Lorraine et du Barrois, etc. 3 Tt. 8vo, 1781.
1903. **Durnall, W. P.** The Internal Combustion Engine. *Trans. Inst. Marine Eng.*, vol. xxii, pp. 363-437. [1911.]
1904. **Dvorkovitz, P.** The Gasification of Coal and Liquid Hydrocarbons. *Journ. Soc. Chem. Ind.*, vol. xii, pp. 403-412. [1893.]
1905. ——— The Flash Point of Petroleum. *Petrol. Rev.*, vol. i, p. 41. [1899.]
1906. ——— The World's Production of Petroleum. *Min. Ind.*, vol. ix, pp. 485-504. [1900.]
1907. ——— A Visit to the American Oil-fields. *Petrol. Rev.*, vol. v, pp. 313-317, 345-348, 369-374, 430-433. [1901.]
1908. ——— The Production of Petroleum in Foreign Countries during 1901 and 1902. *Min. Ind.*, vol. x, pp. 616-625; vol. xi, pp. 507-515. [1902, 1903.]
1909. ——— The Roumanian Oil Industry. *Petrol. Rev.*, vol. viii, pp. 539-544. [1903.]
1910. ——— The Oil Fields of Europe. *Ibid.*, vol. x, pp. 127, 128, 151-154, 223-225. [1904.]
1911. ——— Petroleum, and its Uses for Illumination, Lubricating and Fuel-purposes. *Trans. Inst. Min. Eng.*, vol. xxvii, pp. 495-515. [1904.]
1912. ——— The Kansas and Indian Territory Oil-fields. *Petrol. Rev.*, vol. xi, pp. 403-406, 423, 425, 443, 444, 463, 464. [1904.]
1913. ——— The St. Louis Exposition. *Ibid.*, pp. 483, 484. [1904.]
1914. ——— The Relation of Flash Points to Boiling Points. *Ibid.*, vol. xiii, pp. 7, 8, 24, 25. [1905.]
1915. ——— The World's Supply of Petrol. (From The Car) *Ibid.*, vol. xiv, pp. 269, 270. [1906.]
1916. ——— The Distillation, Cracking, and Gasification of Petroleum Hydrocarbons. *Compt. Rend. Congr. internat. Pétrole*, sess. 3, t. ii, pp. 675-686. [1910.]
1917. ——— The Evolution of the English Oil Trade. *Ibid.*, sess. 3, t. ii, pp. 871-878. [1910.]
1918. **Dyckerhoff, —.** Beiträge zur Autoxydation organischer Stoffe. [1909.]
1919. **Dyer, L. E.** Petroleum Development in Russia. *U.S. Cons. Rep.*, no. 1, pp. 137-159. [1880.]
1920. **Dyer, W. T. T.** On a Substance known as "Australian Caoutchouc." *Journ. Bot.*, ser. 6, vol. i, pp. 103-106, 338, 339. [1872.]
1921. **Dziewonski, C.** Ergebnisse der Untersuchung einiger galizischer Erdöle. *Zeitschr. angew. Chem.*, bd. xiii, pp. 343-345. [1900.]
1922. **Dziewonski, C.** Untersuchung des Gastheeres aus Naphtha-Rückständen. *Naphtha*, bd. ix, pp. 385-387, 405-407. [1901.]
1923. **Dziuk, A.** [Oilfields of Wietze-Steinförde, with map, 1:4000.] 1904.
1924. **E —.** Paraffin Industry of Austria-Hungary. *Petrol. World*, vol. vii, pp. 88-92, 139, 140, 180, 181, 228-231, 254-256. [1910.]
1925. **Eastlake, A. W.** Observations on Petroleum in Eastern Europe, and the Methods of Drilling for it. *Trans. Fed. Inst. M. Eng.*, vol. iii, pp. 693-726, map. [1892.]
1926. **Eaton, A.** Gases, Acids, and Salts, of recent origin and now forming, on and near the Erie Canal, in the State of New York. *Amer. Journ.*, vol. xv, pp. 233-249. [1829.]
1927. ——— Observations on the Coal Formations in the State of New York, in connexion with the Great Coal Beds of Pennsylvania. *Trans. Albany Inst.*, vol. i, pp. 126-130. [1830.]
1928. **Eaton, S. J. M.** Petrolia; a History of the Oil Region of Venango County, Pa., its resources, mode of development, and value, etc. *Philadelphia*, 1866.
1929. **Ebelmen, J. J.** Analyse élémentaire de quelques bitumes minéraux. *Ann. Mines*, sér. 3, t. xv, pp. 523-538. [1839.]  
**Ebelmen, J. J.**, see **Thirria, E.**
1930. **Eberhardt, C. C.** [New Oilfields.] Colombia. Oil in Paying Quantities Discovered near Puerto, Colombia. *U.S. Cons. Rep.*, no. 355, pp. 137, 138. [1910.]
- Eberle, —**, see **Engler, C.**
1931. **Ebler, E.** Chemische Untersuchungen über der Asphalt von Dossenheim bei Heidelberg. *Ber. oberrhein. geol. Ver.*, no. 42, p. 123. [1909.]
1932. **Eck, H.** Ueber das Vorkommen von Bergtheer im ehemaligen Königreich Hannover und im Herzogthum Braunschweig. *Zeitschr. Berg-, Hütt.-Salin.*, bd. xiv, Abh., pp. 346-364. [1866.]
1933. **Edeleanu, L.** The Chemistry of Rumanian Petroleum. *1st Internat. Petrol. Congr.*, pp. 78, 79. [1900.]
1934. ——— [Petroleum v. Coal Tar.] *Monit. Int. Pétrol. Roum.*, t. ii, 1901.
1935. ——— Recherches scientifiques et industrie du pétrole. *Ibid.*, pp. 823-826. [1901.]
1936. ——— [The Technology of Petroleum in the Present and in the Future.] *Ibid.*, t. iii, 1902.
1937. ——— Verwertung der Nitroderivate des Rohöls. *Jüttich Petroleum-Congress [Liège]*. *Naphtha*, bd. xiii, pp. 299-302. [1905.]
1938. ——— Le Pétrole Roumain, sa composition et ses propriétés physiques et techniques. 4to, *Bucharest*, 1907.
1939. ——— Lucrarile executate in Laboratul de Chimie, 1906-1908. *An. Inst. Geol. Roman.*, vol. i, pp. cxii-cxiv; vol. ii, pp. 437-453. [1908, 1909.]
1940. ——— Das Rumänische Erdöl. *Ibid.*, vol. ii, pp. 1-130, 12 tables. [1909.]
1941. ——— Rapport sur l'activité du Laboratoire de Chimie en 1908-1909. *Ibid.*, vol. iii, pp. 407-411. [1910.]
1942. **Edeleanu, L.**, and **S. Dulagea.** Détermination de la viscosité des huiles de graissage avec le viscosimètre Engler. *Ibid.*, vol. iii, pp. 490-505, table. [1910.]
1943. ——— Separation des hydrocarbures aromatiques et des produits résineux du pétrole brut par l'acide sulfurique. *Ibid.*, pp. 511-517. [1910.]
1944. **Edeleanu, L.**, and **G. A. Filiti.** Contribution à l'étude sur les pétroles de Roumanie. *Bull. Soc. Chim. Paris*, sér. 3, t. xxiii, pp. 382-403. [1900.]
1945. **Edeleanu, L.**, and **G. Gané.** Comparaison entre les pétroles étrangers. *An. Inst. Geol. Roman.*, vol. ii, pp. 454-464, 2 pls. [1909.]
1946. ——— ——— Étude comparative sur les pétroles bruts d'origines différentes. *Ibid.*, vol. iii, pp. 443-483, 4 tables, 1 pl. [1910.]

1947. **Edeleanu, L., G. Gané, and H. Löbel.** Hydrocarbures extraits des Goudrons acides du Pétrole. *An. Inst. Geol. Roman.*, vol. i, pp. 365-383. [1908.]
1948. **Edeleanu, L., D. G. Many, G. Pfeiffer, and G. Gané.** Étude sur les lampants obtenus des principaux pétroles bruts roumains. *Ibid.*, vol. iii, pp. 422-432; 5 tables, 10 diagrams. [1910.]
1949. **Edeleanu, L., and J. Tanasescu.** Étude des Pétroles Roumains. *Mon. Inst. Pétrol. Roum.*, t. iv, no. 19, suppl. [1903.]
- Edeleanu, L.,** see **Alimanestianu, C.; Holde, D.;** and **Mrazec, L.**
1950. **Eder, J. M.** Ueber die photochemischen Eigenschaften der natürlichen Asphalte. *Phot. Corresp.*, bd. xvi, pp. 168-175. [1879.]
1951. **Edgerton, H. H.** On the Composition of Permanent Illuminating Gas obtained from the Decomposition of Petroleum Naphtha. *Amer. Journ.*, ser. 3, vol. i, pp. 409-411. [1871.]
1952. ——— Report on the Saratoga Process for the Manufacture of Illuminating Gas from Naphtha. *Memphis*, 1871.
1953. ——— A Report on Petroleum-Naphtha Gas, to the President and Board of Directors of the Fort Wayne Gas-Light Company. *Amer. Gas-Light Journ.*, vol. xiv, pp. 99, 100, 114, 115, 130, 131, 146, 147. [1871.]
1954. **Edwards, J. B.** Petroleum and the Products of its Distillation. *Pharm. Journ.*, ser. 2, vol. iv, pp. 261-262. [1862.]
1955. **Edwards, J. R.** Liquid Fuel for Naval Purposes. *Journ. Amer. Soc. Nav. Eng.*, vol. vi, pp. 744-764. [1895.]
1956. **Eele, M.** On Making Pitch, Tar, and Oil out of a Blackish Stone in Shropshire. *Phil. Trans.*, vol. xix, p. 544. [1697.]
1957. **Effenberger, —.** Praktische Versuche ueber Benzinexplosionen in Gebrauchsgefassen und das Verfahren Martini-Hüneke. *Journ. Gasbel.*, bd. xlix, pp. 689, 690. [1906.]
1958. **Eger, L.** Die Destillationsprodukte des Erdöls in ihrer Verwendung als Leuchtöl. *Chem. Rev. Fett-Harz-Ind.*, bd. vi, pp. 81-91, 121-128, 141-147, 166-168, 190-195. [1899.]
1959. ——— Grundsätze für die Prüfung von Mineral-schmierölen. *Zeitschr. angew. Chem.*, bd. xvii, pp. 1577-1583. [1904.]
1960. **Eggers, H.** Die Asphalt-Quellen am See von Maracibo. *Deutsche geogr. Blätt.*, bd. xix, pp. 183-194. [1896.]
1961. **Egleston, —.** Notes on the Treatment of Mercury in North California. *Trans. Amer. Ins. Min. Eng.*, vol. iii, pp. 273-307. [1875.]
1962. **Ehrenberg, C. G.** Ueber die Dysodilgenannte Mineralspecies. *Ann. Phys. Chem.*, bd. cxxiv, pp. 573-575. [1839.]
1963. ——— Nähere Bestimmung der Mischung des frischen Auswurfs des Schlammvulkans von Iocrowodadi auf Java. *Ber. k. preuss. Ak. Wiss.*, 1858, pp. 570-576.
1964. **Fhrsam, R.** La connaissance des matières lubrifiantes minérales et organiques. *Svo, Paris*, 1904.
1965. ——— Fabrication des Huiles Minérales. *Paris*, 1909.
1966. **Eibner, A., and O. Hué.** Über Terpentintole und ihre Ersatzmittel. I. Bestimmung von Benzinen und Petroleum in Terpentin und Kienölen mittelst Schwefel-säure. *Chem.-Zeit.*, bd. xxxiv, pp. 643-645, 657-659. [1910.]
1967. **Eichfeld, —.** Nachrichten über die Naphta-Quellen und das sogenannte Feuerland bei Baku. *Schr. Russk. k. Ges. Min.*, bd. i, pp. 246-249. [1842.]
1968. **Eichleiter, C. F.** Ueber das Vorkommen und die chemische Zusammensetzung von Anthraciden aus der Silurformation Mittelöhhemens. *Verh. k.-k. geol. Reichs.*, 1899, pp. 348-362.
- Eichleiter, C. F.,** see **John, C. v.**
1969. **Eichler, W.** Einige vorläufige Mittheilungen über das Erdöl von Baku. *Bull. Soc. Imp. Nat. Mosc.*, t. xlviii, pt. 2, pp. 273-296. [1875.]
1970. **Eichwald, E. v.** [Eternal Fire on the Caspian Shore.] *Otetch. Zap.*, 1820, tch. 4, no. 8.
1971. ——— Geognostische Bemerkungen über die Umgebungen des Kaspischen Meeres. *Arch. Min. Geogn.*, bd. ii, pp. 55-93. [1830.]
1972. ——— Reise auf dem Caspischen Meere und in den Caucasus in 1825-26. 3 Bde. 8vo, *Stuttgart*, 1834-1837.
1973. ——— Ein Paar Worte über die Naphta auf der Insel Tschelekan. *Bull. Ac. Imp. Sci. St. Pétersb.*, t. xv, pp. 269-272. [1857.]
1974. **Eicken, —.** Ueber das Niederbringen von Bohrlöchern und Schächten vermittelst durch hohle Bohrgestänge geführten Wasserstromes. *Zeitschr. Berg.-Hütt.-Salin.*, bd. xliii, Abh., pp. 177-189. [1865.]
1975. **Eickmann, R.** Resinous Products in Mineral Oils. *Petrol. Rev.*, vol. xviii, pp. 245, 246, 274. [1908.]
- Eickmann, R.,** see **Holde, D.,** and **Marcusson, J.**
- Eijken, P. A. A. F.,** see **Ottow, M. W.**
1976. **Eijkman, J. F.** Apparat zur Bestimmung der Dampfdichte bei geringem Druck. *Ber. deutsch. chem. Ges.*, bd. xxii, pp. 2754-2758. [1890.]
1977. **Einert, K.** Das Rohöl und seine Verwertung als Heizmaterial. *Petroleum Zeitschr.*, bd. iv, pp. 613-618. [1909.]
1978. **Eisenlohr, H.** Ueber Paraffinbestimmung. *Zeitschr. angew. Chem.*, bd. x, pp. 300-302, 332-336. [1897.]
1979. ——— Beiträge zur Kenntniss des Vergasungsvorganges bei der Vergasung von Gasölen. *Ibid.*, bd. xi, pp. 549-553. [1898.]
1980. **Eisenreich, K.** Beitrag zur Kenntniss des Montanwaxes. *Chem. Rev. Fett-Harz-Ind.*, bd. xvi, pp. 211-213. [1909.]
1981. **Eisenstein, A.** Untersuchungen auf dem Gebiete der organische chemischen Industrie. *Mitt. k.-k. techn. Geuerbenus. Wien.*, n.f., bd. xvii, pp. 30-44. [1908.]
1982. **Eisenstuck, —.** Ueber die Köhlenwasserstoffe, welche den Hauptbestandtheil des Steinöls ausmachen. *Ann. Chem. Pharm.*, bd. cxliii, pp. 169-183. [1861.]
- Eisenstuck, —,** see **Busenius, —.**
1983. **Ekman, F. L.** Kennis Undersökning af "Nullabergarten" från Ostmarks socken i Wermland. *Oefv. k. Vet.-Akad. Förh.*, bd. xxv, pp. 123-157. [1868.]
- Ekman, F. L.,** see **Igelstrom, L. J.**
1984. **Elbs, K.** Beiträge zur Kenntniss der Homologen des Anthracens und Anthracinens. *Journ. prakt. Chem.*, bd. cxlix, pp. 1-32, 121-151. [1890.]
1985. **Eldridge, G.** On the weak points in Steamers carrying Oil in Bulk, and the type which experience has shown to be most suitable for this trade. *Trans. Inst. Naval Archit.*, vol. xxxiii, pp. 88-103, pls. v-viii. [1892.]
1986. **Eldridge, G. H.** The Florence Oil-Field, Colorado. *Trans. Amer. Inst. Min. Eng.*, vol. xx, pp. 442-462. [1892.]
1987. ——— A Geological Reconnaissance in North-west Wyoming. *Bull. U.S. Geol. Surv.*, no. 119, pp. 72, 4 pls. [1894.]
1988. ——— Occurrences of Uintaite in Utah. *Science*, n.s., vol. iii, pp. 830-832. [1896.]
1989. ——— The Uintaite (Gilsonite) Deposits of Utah. *Ann. Rep. U.S. Geol. Surv.*, vol. xvii, pt. i, pp. 915-949, pls. lix, lx. 1896.
1990. ——— The Asphalt and Bituminous Rock Deposits of the United States. *Ann. Rep. U.S. Geol. Surv.*, vol. xxii, pt. i, pp. 209-452, pls. xxv-lviii. [1901.]
1991. ——— The Petroleum Industry in California. *Eng. Min. Journ.*, vol. lxxiii, p. 41. [1902.]
1992. ——— Origin and Distribution of the Asphalt and Bituminous Rock Deposits in the United States. *Bull. U.S. Geol. Surv.*, no. 213, pp. 296-305. [1903.]
1993. ——— The Petroleum Fields of California. *Ibid.*, pp. 305-321. [1903.]
1994. ——— The Formation of Asphalt-veins. *Econ. Geol.*, vol. i, pp. 437-444. [1906.]

1995. **Eldridge, G. H.** The Santa Clara Valley Oil district, Southern California. *Bull. U.S. Geol. Surv.*, no. 309, pp. 1-101, pls. 1-ix. [1907.]
1996. ——— The Puente Hills Oil District, Southern California. *Ibid.*, pp. 102-137, pls. x-xvii. [1907.]
1997. **Eldridge, G. H., and R. Arnold.** The Olinda Oil Field of Southern California. *Petrol. Rev.*, vol. xvii, pp. 109, 110, 137, 138. [1908.]
1998. **Eldridge, G. J.** Report for the years 1887, 1888 on the Trade of Beyrout (Turkey). *Dipl. Cons. Rep.*, ann. ser., nos. 290, 508. [1888, 1889.]
1999. **Elin, I.** The Present Irrational Method of Manufacturing Lubricating Oils in Russia. *Petroleum*, vol. ii, pp. 556-560. [1901.]
2000. **Elenberger, J. G.** Das Petroleum-Terrain Westgaliziens. *Jahrb. k.-k. geol. Reichs.*, bd. xviii, pp. 291-308. [1867.]
2001. **Elliott, A. H.** Literature relating to the Testing and Safety of Kerosene Oil. Report on the Methods and Apparatus for Testing Inflammable Oils. *2nd Ann. Rep. State Board of Health, N. York*, pp. 484-491. [1882.]
2002. ——— A Standard Oil Lamp for Gasworks Photometry. *Journ. Gaslight.*, vol. xciii, pp. 97, 98. [1906.]
2003. ——— Apparatus for distilling gas-oil. *Journ. Soc. Chem. Ind.*, vol. xxix, pp. 193, 194. [1910.]
2004. **Ellis, E. R.** A Hydrocarbon Furnace for Assaying, etc. *Ibid.*, vol. viii, pp. 956, 957. [1889.]
2005. **Ellis, W. H.** Analysis of some Pre-Carboniferous Coals. *Chem. News*, vol. lxxvi, pp. 186-188. [1897.]
2006. **Ellis, W. H., and W. Lawson.** Chemical Notes on the so-called Sudbury Coal. *Proc. Canad. Inst.*, ser. 4, vol. i, pp. 67, 68. [1898.]
2007. **Ellis, W. H.,** see **Coleman, A. P.**
2007. **Ellis, R. W.** Report on the Geology of the Gaspé Peninsula. *Ann. Rep. Geol. Surv. Canada*, 1880-1882, report D, pp. 32. [1883.]
2008. ——— Report on the Geological Formations of Eastern Albert and Westmorland Counties, New Brunswick, and of portions of Cumberland and Colchester Counties, Nova Scotia, embracing the Spring Hill Coal Basin and the Carboniferous System north of the Cobequid Mountains. *Ibid.*, n.s., vol. i, report E, pp. 71. [1885.]
2009. ——— Report on the Mineral Resources of the Province of Quebec. *Ibid.*, n.s., vol. iv, report X, pp. 159. [1890.]
2010. ——— The Physical Features and Geology of the Paleozoic Basin between the lower Ottawa and St. Lawrence. *Trans. Roy. Soc. Canada*, ser. 2, vol. vi, sect. 4, pp. 99-120. [1901.]
2011. ——— Report on the Geology of the Three Rivers Map Sheet, or North-western Sheet of the Eastern Townships Map. *Ann. Rep. Geol. Surv. Canada*, n.s., vol. xi, report J, pp. 70, map. [1901.]
2012. ——— The Oil Fields of Gaspé. *Summary Rep. Geol. Surv. Canada* for 1902, Report A, pp. 340-363, map. [1903.]
2013. ——— The Albert Shale Deposits of Albert and Westmorland Counties, New Brunswick. *Ibid.*, pp. 363-368. [1903.]
2014. ——— Notes on the Mineral Fuel-Supply of Canada. *Trans. Roy. Soc. Canada*, ser. 2, vol. xii, sect. 4, pp. 267-290. [1906.]
2015. ——— Notes on the Geology of Trinidad and Barbados, British West Indies. *Ibid.*, ser. 3, vol. i, sect. 4, pp. 115-130. [1907.]
2016. ——— The Geology and Mineral Resources of New Brunswick. *Canada Dep. Mines*, no. 983. Pp. 135, map. [1907.]
2017. ——— The Carbonaceous and Bituminous Minerals of New Brunswick. *Journ. Canadian Min. Inst.*, vol. xi, pp. 204-219. [1908.]
2018. ——— The Oil Fields of Eastern Canada. *Trans., Nov. Scot. Inst.*, vol. xi, pp. 598-622. [1908.]
2019. ——— Notes on Mineral Fuels of Canada. *Ibid.*, vol. xii, pp. 61-71. [1908.]
2020. **Ells, R. W.** Southern New Brunswick. *Summ. Rep. Geol. Surv. Canada* for 1906, pp. 131-139. [1907.]
2021. ——— Bituminous Shales in Nova Scotia and New Brunswick, with notes on the Oil-shales in Scotland. *Ibid.*, for 1908, pp. 132-142. 8vo, *Ottawa*, 1909.
2022. ——— Notes on the Geology of the Oil-Shales of Scotland, and their Relation to somewhat similar Oil-Shales in Eastern Canada. *Trans. Roy. Soc. Canada*, ser. 3, vol. iii, sect. 4, pp. 35-44. [1909.]
2023. ——— Oil-shales of Eastern Canada. *Summ. Rep. Geol. Surv. Canada* for 1909, pp. 200-216. [1910.]
2024. ——— Geological Position and Character of the Oil-shale Deposits of Canada. *Canada Dep. Mines*, no. 1107. Pp. 75. [1909.]
2025. ——— Report on Tests made in Scotland of Oil shale sent from New Brunswick in the Spring of 1908, with a view of ascertaining its economic value, especially as regards the yield of Crude Oil and Sulphate of Ammonia. *Ibid.*, no. 53. Pp. 61, 15 pls. [1910.]
2026. ——— The Oil-Shales of the Maritime Provinces (Canada). *Journ. Mining Soc. Nov. Scot.*, vol. xiv, pp. 12. [1910.]
2027. ——— The Commercial Value of the Oil Shales of Eastern Canada, based on their Contents by Analysis in Crude Oil and Ammonium Sulphate. *Ibid.*, vol. xv, pp. 29-56. [1910.]
- Ells, R. W.,** see **Bailey, L. W.**
2028. **Elmer, M. F.** Asphalt-Pflastersteine und Asphaltsteinplatten. *Asphalt-Teerind.-Zeit.*, bd. v, pp. 431, 432. [1905.]
2029. **Elphinstone, M.** Account of the Kingdom of Caubul and its Dependencies. 4to, London, 1815.
2030. **Erod, M. N., and A. G. Benedict.** Geology of Wabash County, Indiana. *Ann. Rep. Geol. Surv. Indiana*, vol. xvii, pp. 192-272. [1892.]
2031. ——— Geology of Cass County, Indiana. *Ibid.*, vol. xix, pp. 17-39. [1894.]
2032. **Eschner, C.** Die Asphalte und bituminösen Kalke Palästinas. *Chem. Rev. Fett-Harz-Ind.*, bd. viii, pp. 159, 160, 180-182, map. [1901.]
2033. **Elsner, L.** Ueber die Zusammensetzung des Schieferöl. *Verh. Ver. Beförd. Gewerbf. Preuss.*, bd. xxiv, pp. 195, 196. [1845.]
2034. **Embleton, T. W.** [Notice of Specimens of Vegetable Resin (Middletonite) from Yorkshire Coals.] *Trans. Midland Inst. Eng.*, vol. vi, p. 154. [1878.]
2035. **Emerson, H.** Kerosene, and the important factors of its Combustion. *Horseless Age*, vol. ix, pp. 628-630. [1902.]
2036. **Emerson, H. D.** Long-distance Gas Transmission (Penn.). *Cassier's Mag.*, vol. xxxviii, pp. 19-23. [1910.]
2037. **Emmerling, —.** Eine Gasauströmung bei Apenrade. 1881.
2038. **Emmerling, L. A.** Lehrbuch der Mineralogie. 3 Bde. 8vo, Giessen, 1793-1797.
2039. ——— [Earth-resin from Oberwollstadt, Hesse, between Friedberg and Frankfurt.] *Taschenb. Min.*, bd. x, pp. 287-291. [1816.]
2040. **Emmons, S. F.** Descriptive Geology [of the Fortieth Parallel]. *Rep. Geol. Expt. 40th Par.*, vol. ii, chaps. ii, iii (Green River and Utah Basins). [1877.]
2041. ——— Geological Excursion through Southern Russia. *Trans. Amer. Inst. Min. Eng.*, vol. xxviii, pp. 3-23. [1899.]
2042. **Emmons, S. F., and G. P. Merrill.** Geological Sketch of Lower California. *Bull. Geol. Soc. Amer.*, vol. v, pp. 489-514, pl. 19. [1894.]
2043. **Emtage, R. H.** [Manjak (Bitumen), Barbados.] *Journ. Soc. Arts*, vol. lii, p. 367. [1904.]
2044. **Endemann, H.** The Analysis of Asphalt. *Journ. Soc. Chem. Ind.*, vol. xv, pp. 871-876. [1896]; vol. xvi, pp. 121-126, 427. [1897]; vol. xvii, pp. 1005-1009. [1898.]
2045. **Endlich, F. M.** Report upon the Geology of the San Luis District [Colorado]. *Ann. Rep. U.S. Geol. Surv. Territories*, vol. vi, pp. 305-361. [1874.]

2046. **Endlich, F. M.** Report on the Geology of the White River District [Colorado and Utah]. *Ann. Rep. U.S. Geol. Surv. Territories*, vol. x, pp. 61-131, pls. iii-vii. [1878.]
2047. ——— Catalogue of Minerals found in Colorado. *Ibid.*, pp. 135-159. [1878.]
2048. ——— Report on the Geology of the Sweet-water District [Wyoming]. *Ibid.*, vol. xi, pp. 5-158, pls. i-vi. [1879.]
2049. **Engelbach, T.** Ueber die Destillationsproducte fossiler und anderer Substanzen als Beleuchtungsmittel, und Untersuchung der Destillationsproducte des bituminösen Sandes von Helde in Holstein. *Ann. Chem. Pharm.*, bd. ciii, pp. 1-26. [1857.]
2050. **Engelhard, —.** Das Petroleum, seine Gewinnung und Producte. *Schrift. Ver. Nat. Kennn. Wien*, bd. xiv, p. 107. [1874.]
2051. **Engelhardt, F. E.** Petroleum. *Amer. Journ. Mining*, vol. i, pp. 9, 10, 25, 41, 42, 57, 58. [1866.]
2052. **Engelke, —.** Theerguben und Bohrungen nach Petroleum in Wietze und Steinförde im Lüneburgischen Helde. *Jahresh. nat. Ver. Lüneburg*, 1878.
2053. **Engler, C.** Analyse des Erdwachs. *Ber. Nat. Ges. Halle*, 1868, p. 33.
2054. ——— [Solubility of Metals in Petroleum.] *Ber. deutsch. chem. Ges.*, bd. xii, p. 2186. [1879.]
2055. ——— Ein Apparat zur Prüfung des Petroleums. *Chem. Ind.*, bd. iii, pp. 53-56. [1890.]
2056. ——— Ueber die Feuergefährlichkeit des Petroleums. *Kunst und Gewerbe*, 1882.
2057. ——— Ueber den Zusammenhang zwischen Leuchtkraft, Siedetemperatur und Entzündungspunkt des Petroleums. *Chem. Ind.*, bd. viii, pp. 44-49. [1885.]
2058. ——— Ueber den Gehalt der verschiedenen Erdölarten an Pseudocumol und Mesitylen. *Ber. deutsch. chem. Ges.*, bd. xviii, pp. 2234-2238. [1885.]
2059. ——— Ein Apparat zur Bestimmung der sogenannten Viscosität der Schmieröle. *Chem.-Zeit.*, bd. ix, pp. 189, 190. [1885.]
2060. ——— Das Erdöl von Baku. *Polyt. Journ.*, bd. cclx, pp. 337-353, 433-445, 481-488, 525-535. [1886.]
2061. ——— Neue erhöhrte gewaltige Erdölquelle bei Baku. *Ibid.*, bd. cclxii, pp. 379-381. [1886.]
2062. ——— Beiträge zur Beurtheilung des Petroleums. *Chem.-Zeit.*, bd. x, pp. 1238, 1239. [1886.]
2063. ——— Die deutschen Erdöle. *Verh. Ver. Beförd. Gewerbl. Preuss.*, bd. lxvi, pp. 637-699. [1887.]
2064. ——— Zur Bildung des Erdöls. *Ber. deutsch. chem. Ges.*, bd. xxi, pp. 1816-1827. [1888.]
2065. ——— Die Zersetzung der Fettstoffe beim Erhitzen unter Druck. *Ibid.*, bd. xxii, pp. 592-597. [1889.]
2066. ——— [Comparison of German with American and Caucasian Petroleums.] *Gorn. Journ.*, 1890, t. 3, pp. 310-376.
2067. ——— [Petroleum and Natural Gas. Conference at 63rd meeting of German Naturalists in Bremen.] *Stahl und Eisen*, bd. x, pp. 1102-1104. [1890.]
2068. ——— No. men für das Viscosimeter. *Polyt. Journ.*, bd. cclxxv, pp. 210-212. [1892.]
2069. ——— Ueber die Bildung des Erdöls. *Ber. österr. Ges. chem. Industr.*, bd. xiv, p. 93. [1892.]
2070. ——— On the Artificial Production of Petroleum. *Journ. Amer. Chem. Soc.*, vol. xv, pp. 379-382. [1893.]
2071. ——— Note on the Chemical Qualities of Petroleum from Burmah. *Rec. Geol. Surv. India*, vol. xxvii, pp. 49-53. [1894.]
2072. ——— Die Entstehung des Erdöles. *Chem. Ind.*, bd. xviii, pp. 1-6, 31-37. [1895.]
2073. ——— Der Schwefelgehalt des Petroleums. *Chem.-Zeit.*, bd. xx, pp. 197-199. [1896.]
2074. ——— Zur Frage der Entstehung des Erdöls und über die Selbstpolymerisation der Kohlenwasserstoffe. *Ber. deutsch. chem. Ges.*, bd. xxx, pp. 2358-2365. [1897.]
2075. ——— Zur Geschichte der Bildung des Erdöls. *Ibid.*, bd. xxxiii, pp. 7-21. [1900.]
2076. **Engler, C.** The Chemistry of the Formation of Petroleum. *1st Internat. Petrol. Congress*, pp. 17-22. [1900.]
2077. ——— Ueber das Petroleum im Rheintal. *Chem. Ind.*, bd. xxv, pp. 61-64. [1902.]
2078. ——— Méthode de dosage de l'asphalte, du Brai, et de la Paraffine dans le Pétrole brut. *Journ. Pétr.*, t. iv, pp. 7, 8. [1904.]
2079. ——— Die Petroleumindustrie mit besonderer Rücksicht auf Unterscheidung des rohen Erdöls von seinen Destillaten und Rückständen. *Compt. Rend. Congr. internat. Chim. appl.*, sess. 5, t. ii, pp. 488-495. [1904.]
2080. ——— [The Occurrence of Petroleum in the Rhine Valley.] *Allg. österr. Chem.-Techn.-Zeit.*, bd. xxiv, pp. 49, 50, 58-61. [1906.]
2081. ——— Zur Frage der Entstehung des Erdöls. *Chem.-Zeit.*, bd. xxx, pp. 711-714. [1906.]
2082. ——— Beiträge zur Chemie und Physik der Erdölbildung. *Petroleum Zeitschr.*, bd. ii, pp. 849-853, 912-916, 964-967, 1021-1025. [1907.]
2083. ——— Cholesterin, das Substrat der optischen Aktivität des Erdöls. *Ibid.*, bd. iii, pp. 60-64. [1907.]
2084. ——— Die Entstehung des Erdöls. *Zeitschr. angew. Chem.*, bd. xxi, pp. 1585-1597. [1908.]
2085. ——— Die neuere Ansichten über die Entstehung des Erdöls. *Svo, Berlin*, 1908.
2086. ——— Die Frage der Entstehung des Petroleums. *Compt. Rend. Congr. internat. Pétr.*, sess. 3, t. ii, pp. 1-36. [1910.]
2087. ——— La Réserve de Pétrole du Globe. *Echo Mines Métall.*, 1911.
2088. ——— Das Bitumen. *Chem.-Zeit.*, bd. xxxvi, pp. 65, 66, 82-84. [1912.]
2089. **Engler, C., and E. Albrecht.** Ueber den Vorgang bei der Filtration der Petroleum durch Floriaderde. *Zeitschr. angew. Chem.*, bd. xiv, pp. 889-892. [1901.]
2090. ——— Ueber die Petroleum einschüsse im Muschelkalk von Roth-Malsch in Baden. *Ibid.*, pp. 913-916. [1901.]
2091. **Engler, C., and M. Böhm.** Ueber die chemische Natur des Vasellins. *Polyt. Journ.*, bd. cclxii, pp. 468-475, 524-530. [1886.]
2092. **Engler, C., and — Eberle.** Die neuere Ansichten über die Entstehung des Erdöls. *Berlin*, 1907.
2093. **Engler, C., and R. Haass.** Die Prüfung des Petroleums auf seine Feuergefährlichkeit. *Zeitschr. anal. Chem.*, bd. xx, pp. 1-36. [1881.]
2094. ——— Zur Prüfung des Petroleums. *Ibid.*, pp. 362-369. [1881.]
2095. **Engler, C., and H. Höfer.** Die Geologie und Gewinnung des Erdöls. 1905.
2096. ——— Das Erdöl, seine Physik, Chemie, Technologie und sein Wirtschaftsbetrieb. 5 Bde. *Svo, Leipzig*. [1909- ]
2097. **Engler, C., and L. Jezioranski.** Ein Beitrag zur Kenntniss der elementären Zusammensetzung der Erdöle. *Ber. deutsch. chem. Ges.*, bd. xxviii, pp. 2501-2505. [1895.]
2098. **Engler, C., L. Jezioranski, H. Grüning, and C. Schneider.** Die Zersetzung hochmolekularen Kohlenwasserstoffe durch mässige Hitze. *Ibid.*, bd. xxx, pp. 2908-2920. [1897.]
2099. **Engler, C., and E. Kneiss.** Sauerstoffübertragung und lösende Wirkung von flüssigen Kohlenwasserstoffen auf Metalle. *Polyt. Journ.*, bd. cclxiii, pp. 193-200. [1887.]
2100. **Engler, C., and A. Künkler.** Viscosimeter zur Prüfung von Oelen bei konstanter Temperatur. *Polyt. Journ.*, bd. cclxxvi, pp. 42-47. [1890.]
2101. ——— Bemerkungen zu der vorstehenden Abhandlung des Herrn Martens über die Bestimmung des Flüssigkeitsgrades von Schmieröl. *Ibid.*, bd. cclxxix, pp. 115, 116. [1891.]
2102. **Engler, C., and Th. Lehmann.** Bildung von Olefinen, Naphtenen und Benzolkohlenwasserstoffen durch Destillation der Pette unter Ueberdruck. *Ber. deutsch. chem. Ges.*, bd. xxx, pp. 2365-2368. [1897.]

2103. Engler, C., and I. Levin. Vergleichende Versuche über die Eigenschaften des kaukasischen und des amerikanischen Erdöles. *Polyt. Journ.*, bd. cclxi, no. 29-34, 77-87. [1886.]
2104. Engler, C., and G. Otten. Ueber ein Erdöl aus Argentinien. *Ibid.*, vol. cclxviii, pp. 375-381, 467-475. [1888.]
2105. Engler, C., and L. Rosner. [Examination of Cracking Gases of Baku oil.] *Allg. österr. Chem.-Techn.-Zeit.*, bd. xxiv, no. 9. [1906.]
2106. Engler, C., F. O. Routala, and B. Halmal. Ueber Naphthenbildung im Erdöl. *Ber. deutsch. chem. Ges.*, bd. xlii, pp. 4610-4631 [1909]; bd. xliii, pp. 388-411. [1910.]
2107. Engler, C., and S. Seidner. Ueber die Zersetzung der Fettstoffe beim Erhitzen unter Druck. *Polyt. Journ.*, bd. cclxii, pp. 515-526, 572-576. [1889.]
2108. Engler, C., and L. Singer. Nachweis von Paraffin und von Schmieröl in dem Druckdestillat des Fischthrans. *Ber. deutsch. chem. Ges.*, bd. xxvi, pp. 1449-1451. [1893.]
2109. Engler, C., and W. Steinkopf. [Cholesterine in Java Petroleum.] *Journ. Russk. Phys. Khim. Obsch.*, t. xliii, otd. 1, pp. 1820-1825. [1911.]
2110. Engler, C., and L. Strippelmann. Der Bentheimer Asphalt unter Hinweisung auf analoge Vorkommen in Italien in geologisch-bergmännischer und chemisch-technischer Beziehung. *Polyt. Journ.*, bd. ccl, pp. 216-227, 265-271, 316-321. [1884.]
2111. English, T. Coal- and Petroleum-Deposits in European Turkey. *Quart. Journ. Geol. Soc.*, vol. lviii, pp. 150-162, pl. iv. [1902.]
2112. ———. Eocene and Later Formations surrounding the Dardanelles. *Ibid.*, vol. ix, pp. 243-295, pls. xxi-xxiii. [1904.]
2113. Ennis, W. D. Burning Oil for Power and Heating. *Power*, vol. xxviii, pp. 943-947, 980-984. [1908.]
2114. Ensley, J. J. Report for the years 1887, 1889 on the Trade of Nagasaki. *Dipl. Cons. Rep.*, ann. ser., nos. 403, 754. [1888, 1890.]
2115. Erben, —. Vergiftungen. *Vienna*, 1909.
2116. Erbecciano, L. C. [The Flow of Petroleum in Pipes.] *Monit. Int. pétr. Roum.*, t. vii, no. 38. [1907.]
2117. ———. Débouchés créés ans dérivés du pétrole par l'emploi du combustible liquide dans la navigation maritime mondiale. *Journ. Pét.*, t. xi, pp. 245-248. [1911.]
2118. Erdmann, E. Salthaltigt vatten in Triaslagren vid brunnsborningar Helsingborg. *Geol. Fören. Stockholm Förh.*, bd. iv, pp. 272-276. [1879.]
2119. Erdmann, H. Ueber das Kaukasische Erdöl. *Zeitschr. Naturw.*, bd. lxx, pp. 31-51. [1892.]
2120. Ermiev, P. V. [Investigation of the Oil Deposits of Kazan, Simbirsk and Samara.] *Gorn. Journ.*, 1867, t. 1, pp. 333-361, 475-496, pl. 3.
2121. ———. [Russian Petroleum and Asphalt.] *Verh. russ. k. min. Ges.*, n.f., bd. iii, pp. 374-382. [1868.]
2122. Erismann, F. Ueber die bei den Münchener Preisen aus der verschiedenen Beleuchtungsart erwachsenden Kosten. *Polyt. Journ.*, bd. cccxxv, pp. 587, 588; bd. cccxxvi, p. 648. [1877.]
2123. Erlennmeyer, E. see Wanklyn, J. A.
2124. Ermeling, J. P. Eindverslag over de diepe grondpeiling ten behoeve van eenen arteiseshen put te Grisséc. *Ind. Bijdr. Tijdschr. k. Inst. Ing.*, dl. 1, pp. 5-13, pl. iv. [1869.]
2125. Ermeling, J. P., and P. v. Dijk. Rapport sur la sondage à vapeur pour la recherche d'eau potable à Grisse, île de Java. *Tijdschr. Kon. Inst. Ned. Ing.*, 1869-70.
2126. Ernecke, A., und — Haunemann. Ueber die Prüfung von Petroleum und Solaröl auf Entzündbarkeit. *Deutsch. Ind. Zeit.*, 1870, p. 52.
2127. Erni, H. Coal-oil and Petroleum; their origin, history, geology, and chemistry. *Svo, Philadelphia*, 1865.
2128. Ernst, A. Geognostische und bergbauliche Skizzen über die Kaukasus-Länder. *Svo, Hannover*, 1891.
2129. Ernst, A. Die Kohlenwasserstoffquellen Siebenbürgens in Verbindung mit unterirdischen Erdölsammungen. *Berg. Hütt. Zeit.*, bd. lviii, pp. 278-281. [1899.]
2130. Ernst, C. R. v. Das Petroleum-Vorkommen und die Erdölindustrie in Italien. *Zeitschr. Oesterr. Ing.-Archiv.-Ver.*, bd. xiv, pp. 261, 262. [1893.]
2131. Erophiiev, D. S. S. [Report on his Expedition of 1877 in Samara, Simbirsk, and Kazan.] *Gorn. Journ.*, 1878, t. 2, pp. 61-71.
2132. Erskine, T. E. Report on the Trade of the Consular District of St. Louis [Mo.] for the year 1910. *Dipl. Cons. Rep.*, ann. ser., no. 711. [1911.]
2133. Escard, J. La Fabrication Industrielle des Charbons. *Genie Civ.*, t. lix, pp. 326-328. [1911.]
2134. Esch, W. Asphalte, Wachse, Oele und Faktis in Gummi-Mischungen. *Chem. Rev. Fett-Harz-Ind.*, bd. xviii, pp. 56-59. [1911.]
2135. Espagne, A., and L. Sardon. Deux cas d'eczéma par l'action locale del'huile de pétrole commerciale. *Gaz. hebdom. Sci. Méd. Montpelier*, t. xiii, pp. 193-195. [1891.]
2136. Espitalier, G. F. Le Granit-asphalte et l'Asphalt armé. *Rev. Gén. Milit.*, t. xxxi, pp. 63-74. [1906.]
2137. ———. Note sur l'organisation des Rues des Grandes Villes. *Svo, Paris*, 1908.
2138. Etard, A., and P. Lambert. Sur un carbure de la série terpénique contenu dans les huiles du gaz comprimé. *Compt. Rend.*, t. cxii, pp. 945-947. [1891.]
2139. Etwein, L. Einiges über Wollspickmittel. *Seifen-Ind.-Zeit.*, bd. xxxiii, p. 129. [1906.]
2140. Eulenburg, H. Handbuch des öffentlichen Gesundheitswesens. *Berlin*, 1882.
2141. Evans, A. F. The Internal Combustion Engine as a Means of Propelling Small Vessels. *Trans. Inst. Naval Archit.*, vol. xvi, pp. 151-161. [1904.]
2142. ———. On the Oil-producing Uplift of West Virginia. *Ibid.*, vol. xlii, pp. 334-343. [1866.]
2143. Evans, H. A. Oil as Fuel in Forges. *Iron Trade Rev.*, vol. xviii, pp. 75-81, 138-142. [1911.]
2144. Evans, J. W. The Principal Petroleum Resources of the British Empire. Part II, India. *Bull. Imp. Inst.*, vol. ii, pp. 97-103; Part III, West Indies, pp. 175-184. [1904.]
2145. ———. Oilfields of Trinidad. *Ibid.*, vol. vi, pp. 196-200. [1903.]
2146. Evans, Lewis. A General Map of the Middle Colonies of America. *Philadelphia*, 1755.
2147. Everest, C. M. [Petroleum Lubricants.] *Amer. Manuf.*, 1895, p. 23.
2148. Everett, A. H. Notes on the Distribution of the useful Minerals in Sarawak. *Journ. Straits Branch R. A. Soc.*, July 1873, pp. 13-30.
2149. Everett, S. B. Petroleum in the Dutch East Indies. *U.S. Cons. Rep.*, vol. lvii, pp. 54, 55. [1898.]
2150. ———. American Petroleum in Java. *Ibid.*, pp. 380, 381. [1898.]
2151. Everwijn, R. Iets over aardolie in de residentie Cheribon op Java. *Jaarb. Mijne. Ned. O.-Ind.*, jg. iii, dl. 1, pp. 167-171. [1874.]
2152. ———. Mededeeling omtrent het voorkomen van aardolie in het rijkje Perak op Sumatra's-Oostkust. *Ibid.*, jg. v, dl. 1, pp. 186, 187, 1876.
2153. ———. Onderzoek naar kolen in de residentie Palembang. *Ibid.*, jg. viii, dl. 2, pp. 163-171, pl. [1879.]
2154. Evrard, —. Notice sur des outils de sondage servant à déterminer l'inclinaison et la direction des terrains schisteux. *Ann. Mines*, sér. 3, t. xviii, pp. 53-58. [1840.]
2155. Evrard, —, and — Dislère. Sur les Huiles de Pétrole. *Douay*, 1866.
2156. Evrard, A. Les recherches de pétrole dans le Département d'Oran (Algérie). *Gen. Civ.*, t. xxix, pp. 235-237, map. [1896.]

2157. **Fwing, J. A.** The Steam Engine and Other Heat Engines. 8vo Cambridge, 1894.
2158. ——— The Trials of Portable Oil Engines at Cardiff. *Journ. Roy. Agric. Soc.*, vol. lxii, pp. 158-179. [1901.]
2159. ——— The Mechanical Production of Cold. 8vo, London, 1908.
2160. **Eyres, H. C. A.** Petroleum and Asphalt Mine [Turkey]. *Board of Trade Journ.*, vol. lxx, p. 268. [1910.]
2161. **Eyres, H. W.** Report for the year 1889 on the Trade of Beyrout. *Dipl. Cons. Rep.*, ann. ser. no. 720. [1890.]
2162. **Eyrins, Eirini d'.** Dissertation sur l'asphalte ou ciment naturel, découvert depuis quelques années au Val de Travers. Paris, 1721.
2163. **F.** Zur Kenntniss des Erdöls. *Polyt. Journ.*, bd. ccxxviii, pp. 531-543. [1878.]
2164. ——— Die erste grössere Erdölgrube und Raffinerie Galziens. *Oesterr. Zeitschr. Berg-Hütt.*, bd. xxix, pp. 77, 78. [1881.]
2165. ——— Ueber die Untersuchung von Erdöl. *Polyt. Journ.*, bd. ccxliii, pp. 476-481; ccxiv, pp. 165-171; ccl, pp. 169-172. [1882, 1883.]
2166. **F.**, **E.** Réservoirs à combustibles pour la marine. *Journ. Pét.*, ann. xi, pp. 81, 82. [1911.]
2167. **F.**, **V.** [German Oilsprings.] *Gornozavodsk. Listok*, 1888, no. 24.
2168. **F.**, **W.** Neue Asphaltlagerstätte im Kaukasus. *Berg-Hütt. Rundsch.*, bd. iii, p. 255. [1907.]
2169. **Faber, G. L.** Report for the Year 1886 on the Trade of Fiume. *Dipl. Cons. Rep.*, ann. ser., no. 141. [1887.]
2170. **Faber, P. J.** Palladium Spagiricum. 8vo, Paris, 1624.
2171. **Fabian.** — Ein Abfallstück am Bohrgestänge. *Arch. Min. Geogn.*, bd. xxii, pp. 206-214. [1848.]
2172. **Fabianski, J.** Ueber das Erdölorkommen in der Marmaros. *Montan-Zeit. Oesterr.-Ung. Balkanl.*, bd. iii, p. 293. [1894.]
2173. ——— Schiefe Bohrlöcher und Spülbohrfrage. *Petroleum Zeitschr.*, bd. ii, pp. 429-437. [1907.]
2174. ——— [Flush-drilling.] *Ropa*, 1911, no. 8.
2175. **Fabris, G.**, see Villavecchia, V.
2176. **Fabritius, W.** Die heutige Stadt Baku und die Naphtha-Industrie in ihrer Umgegend. *Russ. Revue*, bd. x, pp. 33-50. [1877.]
2177. **Fader, A.** Asphalt und Ozokerit. *Chem. Rev. Fett-Harz-Ind.*, bd. xii, p. 106. [1905.]
2178. **Fairbanks, H. W.** Notes on the Geology and Mineralogy of Portions of Tehama, Colusa, Lake and Napa Counties. *11th Ann. Rep. State Mineral. California*, pp. 51-75. [1893.]
2179. ——— The Possibilities of the Petroleum Industry in California. *Eng. Min. Journ.*, vol. lxi, p. 538. [1896.]
2180. ——— Notes on a breathing Gaswell. *Science*, n.s., vol. iii, pp. 693, 694. [1896.]
2181. ——— Bituminous Rock Deposits in the vicinity of San Luis Obispo, California. *Min. Sci. Press.*, vol. lxxvi, p. 661. [1898.]
2182. ——— Some Notes on the Petroleum Deposits of California. *Ibid.*, vol. lxxviii, p. 533. [1899.]
2183. ——— The Oil-yielding Formations of Monterey, San Luis Obispo and San Benito Counties. *Bull. Calif. State Min. Bureau*, no. 19, pp. 143-150. [1903.]
2184. ——— San Luis Obispo (California). *Fo.* 101, *U.S. Geol. Survey*, 1904.
2185. **Fairlie, D. M.**, see Pring, J. N.
2186. **Fairman, E. St. J.** A Treatise on the Petroleum Zones of Italy. 8vo, London, 1868
2187. **Falloppeus, H.** De Thermis, ca. 1570.
2188. **Falsan, A.**, and **A. Locard.** Monographie Géologique du Mont d'Or, Lyonnais, et de ses dépendances. *Ann. Soc. Agric. Lyon*, sér. 3, t. x, pp. 241-339; t. xi, pp. 1-288, xliii. [1866, 1867.]
2189. **Fama, A.** Procédé pour l'épuration des essences minérales dérivées du pétrole, et produit qui en résulte. *Journ. Pét.*, t. vii, pp. 220, 221. [1907.]
2190. **Fane, E.** Report for the year 1891 on the Trade of Servia. *Dipl. Cons. Rep.*, ann. ser., no. 1295. [1893.]
2191. **Faraday, M.** On New Compounds of Carbon and Hydrogen, and on certain other Products obtained during the Decomposition of Oil by Heat. *Phil. Trans.*, 1825, pp. 440-466
2192. **Faramond de Lafalole.** — de. Moteurs à Pétrole. *Soc. Ing. Civ. France*, Cinquantenaire, pp. 374-387. [1898.]
2193. **Farey, J. A.** General view of the Agriculture and Minerals of Derbyshire; drawn up for the consideration of the Board of Agriculture. 2 vols. 8vo, London, 1811, 1813.
2194. **Farez.** — Quelques traits de l'histoire du Pétrole, son origine et celle de l'houille. 8vo, 1876.
2195. **Farez, E.**, and — **Boulanger.** Mémoire sur les huiles employées au graissage des machines. *Bull. Soc. Ind. Mulh.*, t. xlv, pp. 202-225. [1875.]
2196. **Farrar, J. S.** Petroleum Wells and Industry of Canada. *Rep. Cons. U.S.*, vol. xxvi, pp. 302-304. [1888.]
2197. **Farrel, F. J.**, and **F. Howies.** Germicidal power of Petroleum Benzine. *Journ. Soc. Dyers Colourists*, vol. xxiv, pp. 109-112. [1908.]
2198. **Faucq, A.** Ueber Petroleum-Gewinnung in Galizien und Amerika. *Berg-Hütt-Zeit.*, bd. xxxi, pp. 351, 352. [1872.]
2199. ——— Die Petroleumgruben in Bobrka in Galizien. *Ibid.*, bd. xxxii, p. 284. [1873.]
2200. ——— Die Erdwachs- und Petroleumgruben zu Boryslaw in Galizien. *Ibid.*, bd. xxxiii, pp. 440, 447. [1874.]
2201. ——— Die Petroleumgruben Galziens. *Oesterr. Zeitschr. Berg-Hütt.*, bd. xxiii, pp. 28, 29. [1875.]
2202. ——— Die erste grössere Erdölgrube und Raffinerie Galziens. *Ibid.*, bd. xxix, pp. 77, 78. [1881.]
2203. ——— Die Erdölquellen von Baku am Kaspischen Meere. *Ibid.*, pp. 265-268. [1881.]
2204. ——— Fortschritte der Erdbohrtechnik. *Leipsic*, 1885.
2205. ——— Boring Machinery in Petroleum Mining. *1st Internat. Petrol. Congr.*, pp. 74, 75. [1900.]
2206. ——— Ein Dritteljahrhundert der Entwicklung der Tiefbohrtechnik in Galizien. *Montan-Zeit. Oesterr.-Ung. Balkanl.*, bd. viii, pp. 369, 370. [1901.]
2207. ——— Tiefbohrtechnische Fragen. *Naphtha*, bd. ix, pp. 132, 133; bd. xii, pp. 305-307. [1901, 1904.]
2208. ——— Rumänischen Petrolindustrie. *Ibid.*, bd. ix, pp. 151, 152. [1901.]
2209. ——— Die Frage der Verwässerung von Petroleum bohrlöchern durch Spülbohrungen. *Ibid.*, pp. 165, 166. [1901.]
2210. ——— Hydraulische Tiefbohrapparate. *Ibid.*, pp. 291, 292. [1901.]
2211. ——— Neue Fortschritte der Tiefbohrtechnik. *Ibid.*, pp. 346, 347, 363, 364. [1901.]
2212. ——— Die Einführung der kleinen Fallböden für Tiefbohrungen. *Ibid.*, pp. 443-446. [1901.]
2213. ——— Die Probleme der Tiefbohrtechnik. (XVI intern. Vers. Bohring.) *Naphtha*, bd. x, pp. 378-380. [1902.]
2214. ——— Petroleum und Spiritus auf Grundlage der Steuerverhältnisse für Erstes. *Ibid.*, pp. 407-409. [1902.]
2215. ——— Feuer, Wasser und Petroleum. *Naphtha*, bd. xii, pp. 37, 38. [1904.]
2216. ——— Wird das Erdöl durch Wasserspülbohrung verdrängt. *Ibid.*, pp. 326, 327. [1904.]
2217. ——— Wasserspülung bei Petroleumbohrungen. *Ibid.*, bd. xiii, pp. 1-4, 50-53. [1905.]
2218. ——— Petroleumgewinnungs Arbeiten. *Ibid.*, pp. 255-257. [1905.]
2219. ——— Der wirtschaftliche Wert der galizischen Erdöl-Produktion. *Ibid.*, bd. xiii, pp. 423-426. [1905.]

2218. **Fauk, A.** Die Gewinnung des Erdöles nach verschiedenen Bohrmethodeu. *Petroleum Zeitschr.*, bd. I, pp. 45-49. [1905.]
2219. ——— Warum waren bisher alle Tiefbohrungen auf Erdöl in Ungarn erfolglos? *Naphta*, bd. xiv, pp. 84, 85. [1906.]
2220. ——— Erweiterung des Petroleum-Verbrauchs-Gebietes. *Ibid.*, pp. 367, 368. [1906.]
2221. ——— Die Ursachen der Abweichung der Tiefbohrungen vom Lot. *Oesterr. Zeitschr. Berg-Hütt.*, bd. IV, pp. 233-235. [1907.]
2222. ——— Über Fragen der galizischen Petroleum-Industrie. *Zeitschr. österr. Ing.-Archit.-Ver.*, bd. IX, p. 604. [1908.]
2223. ——— Kritische Besprechung des Berichtes des volkswirtschaftlichen Ausschusses. *Allg. österr. Chem.-Techn.-Zeit.*, bd. XXVIII, pp. 145-147. [1909.]
2224. ——— Ursprung, Aufsuchung und Verwendung von Kohle und Petroleum. *Zeitschr. österr. Ing.-Archit.-Ver.*, bd. XLII, p. 685. [1910.]
2225. ——— Die Frage der Umlagerstätten des Erdöles. *Org. Ver. Bohrtechn.*, bd. XVIII, pp. 49-51. [1911.]
2226. ——— Wasserspülbohrung und Wassereintriche in Tustanowice. *Ibid.*, pp. 187, 188. [1911.]
2227. ——— Spülbohrung in unaufgeschlossenen Oelfeldern. *Ibid.*, pp. 219, 220. [1911.]
2228. **Faujas-Saint-Fond, B.** Sur le Caoutchouc, ou Bitume élastique fossile du Derbyshire. *Ann. Mus. Hist. Nat. Paris*, t. I, pp. 261-272. [1799.]
2229. **Favre, A.** Description géologique du Canton de Genève. 2 Tl. 8vo, Geneva, 1890; map (1879), 1 : 25,000, in 4 sheets.
2230. **Favre, E.** Recherches géologiques dans la Partie Centrale de la chaîne du Caucase. 4to, Geneva, Basle, and Lyons, 1875.
2231. **Favre, L.** [Bituminous Deposits of Lobsann and Pechelbronn, Elsass.] *Bull. Soc. Sci. Nat. Neuchâtel*, t. XI, pp. 122-125. [1878.]
2232. **Favre, P. A.** and **J. T. Silbermann.** Combustion du gaz des marais et du gaz oléifiant. *Compt. Rend.*, t. XX, pp. 1734-1736. [1845.]
2233. **Fazzello, T.** Rerum Sicularum Scriptores in unum Corpus congesti. Fo, Palermo, 1553.
2234. **Feldhaus, F. M.** Beiträge zur Geschichte des Erdöles. V, Das Erdöl in der Luftschiffahrt. VI, Das Erdöl im griechischen und römischen Altertum. VII, Die erste Beschreibung des deutschen Erdöls. *Petroleum Zeitschr.*, bd. V, pp. 633, 634, 1241, 1242, 1387-1390. [1910.]
2235. ——— *Idem.* VIII, Das Erdöl als Waffe. IX, Die ersten Nachrichten vom Amerikanischen Erdöl. X, Freiherr von Dücker, ein Vorkämpfer für das deutsche Petroleum. XIV, Petroleum in Preussen im 1697. *Ibid.*, bd. VI, pp. 382, 383, 438, 658; bd. VII, p. 65. [1911.]
2236. **Feldmann, K.** Die erste Naturgasfernleitung im galizischen Erdölgebiet. *Ibid.*, bd. VI, pp. 2232-2235. [1911.]
2237. ——— Die Verwertung von Naturgasen durch Verbrennung unter Dampf- und Destillierkesseln. *Ibid.*, bd. VII, pp. 285-288. [1911.]
2238. **Felix, J.** Hygienische Studien über Petroleum und seine Destillate. *Deutsch. Viertelj. Gesundh.*, 1872, p. 226.
2239. **Felkner, —.** Coup d'œil sur la Composition Géologique de la rive orientale de la Mer Caspienne, compté entre le Golfe d'Asterabad et le Cap Tukaragane d'après des observations faites en 1836. *Ann. Journ. Mines Russie*, 1838, pp. 129-190.
2240. **Fellner, A.** Nochmals die Welscher Gasbrunnen. *Verh. k.-k. geol. Reichs.*, 1892, p. 266
2241. **Fenaroli, P.**, see **Molinari, E.**
2242. **Fendler-Steglitz, G.** Floricin, ein mit Mineralölen mischbares Produkt aus Ricinusöl. *Ber. deutsch. pharm. Ges.*, bd. III, pp. 135-138. [1904.]
2243. **Fenn, R. W.** Caloric Value of California Fuel Oil. *Engineering News*, vol. LXI, pp. 516-518. [1909.]
2244. **Fennema, R.** Rapport omtrent het Voorkomen van Petroleum in Beneden-Langkat, Oostkust van Sumatra. *Jahrb. Mijnw. Ned. O. Ind.*, Jg. XIX, pp. 10-91, 2 maps. [1890.]
2245. **Fennema, R.**, see **Verbeek, R. D. M.**
2246. **Fenneman, N. M.** The Boulder, Colo., Oil Field. *Bull. U.S. Geol. Surv.*, no. 213, pp. 322-332. [1903.]
2247. ——— Structure of the Boulder Oil Field, Colorado, with Records for the Year 1903. *Ibid.*, no. 225, pp. 383-391. [1904.]
2248. ——— The Florence, Colo., Oilfield. *Bull. U.S. Geol. Surv.*, no. 260, pp. 436-440. [1905.]
2249. ——— Oilfields of the Texas-Louisiana Gulf Coast. *Ibid.*, pp. 459-467. [1905.]
2250. ——— Geology of the Boulder District (Colo.). *Ibid.*, no. 265. Pp. 101, 5 pls. [1905.]
2251. ——— Oil Fields of the Texas-Louisiana Gulf Coastal Plain. *Ibid.*, no. 282. Pp. 146; 11 pls. [1906.]
2252. ——— Geology and Mineral Resources of the St. Louis Quadrangle, Missouri-Illinois. *Ibid.*, no. 438. Pp. 73; 6 pls. [1911.]
2253. **Fenner, A.** [Punjab Oil.] *Proc. Punjab Govt. Public Works Dept.*, June 17, 1866.
2254. ——— Report on Borings for Petroleum. *Ibid.*, July 1869, pp. 2-6.
2255. **Fenning, R. W.**, see **Watson, W.**
2256. **Ferber, J. J.** [Travels through Italy, in the Years 1771 and 1772 (mineralogical notes).] 8vo, London, 1776.
2257. ——— Enodiato questionis an Indoles matrix metallifera et metalli quod continent, notam præbet certam qua dignosci possunt montes primarii a secundariis. *N. Act. Ac. Sci. Imp. Petropol.*, t. IV, pp. 284-290. [1789.]
2258. **Ferguson, A. W.** Mexico. *Bull. Bureau Amer. Republ.*, no. 9. [1891.]
2259. **Ferguson, W.** On the Mud-Volcanoes in Trinidad. *Trans. Roy. Soc. Edinb.*, vol. IX, pp. 93-96. [1823.]
2260. **Fernald, R. H.** The Gas Power Field for 1911. *Journ. Amer. Soc. Mech. Eng.*, vol. XXXIV, pp. 105-113. [1912.]
2261. **Fernandez de Castro, M.** Pruebas paleontológicas de que la isla de Cuba ha estado unida al continente americano, y breve idea de su constitucion geologica. *Bol. Com. map. geol. Esp.*, t. VIII, pp. 357-372. [1881]; map in t. XI. [1884.]
2262. **Ferrara, F.** Memorie sopra il Lago Naftia nella Sicilia meridionale; sopra l'Ambre Siciliana, etc. 8vo, Palermo, 1805.
2263. ——— Storia Naturale della Sicilia. Catania, 1813.
2264. ——— Mémoire sur le Lac Nafta. *Journ. Pharm.*, t. VI, pp. 197-201. [1820.]
2265. **Ferrario, O.** Analisi chimica degli scisti bituminosi, della valle di Setaroto. *Atti R. Ist. Lomb.*, t. III, pp. 15-18. [1862.]
2266. **Ferrero, O. L.** Studj sui combustibili della Provincia [di Bergamo]. *Atti Soc. Ital. Sci. Nat.*, t. X, pp. 345-353. [1867.]
2267. ——— Saggi di combustibili, calcari, cementi e minerali lombarde. *Ibid.*, t. XI, pp. 902-915. [1868.]
2268. ——— Contribuzione allo studio dei materiali litologici della provincia di Terra di Lavoro. *Caserta*, 1879.
2269. **Ferretti, A.** Le salse o vulcani di fango e le argille scagliose. *Padua*, 1878.
2270. ——— Sopra i vulcani di fango e le argille scagliose del Modenese. *Boll. R. Com. geol. Ital.*, ann. IX, pp. 174-187. [1878.]
2271. **Ferry, D. S.** The Transportation of Natural Gas. *Power*, vol. XXV, pp. 724, 725. [1905.]
2272. **Fessenden, R. A.** Action of Nitric Acid on Asphalt and Cellulose. *Chem. News*, vol. LXV, p. 136. [1892.]
2273. **Feuchtwanger, L.** Origin of Petroleum. *Coll. Guard.*, vol. XIV, p. 53. [1867.]
2274. **Flochet, P. A.** Sur l'emploi économique des combustibles. *Mém. Soc. Ing. Civ.*, 1874, pp. 77-80, 85, 86.
2275. ——— Études sur la Combustion et sur la Construction Rationnelle des Foyers Industriels. *Ibid.*, pp. 670-711.



2273. **Fichtel, J. E. v.** Nachricht von der Versteinerungen des Grossfirnthums Siebenbürgen, . . . 4to, *Nuremberg*, 1780.
2274. **Fiesinisco, T., and V. Dessia.** Note sur l'Exploitation du Pétrole en Roumanie, Campina-Buxtenari. *Rev. Univ. Mines*, ser. 4, t. xix, pp. 285-302. [1907.]
2275. **Fieberger, G. J.** Report on Bermudez Asphalt. *Rep. Operat. Eng. Dep. D. C.*, 1894, pp. 143-146.
2276. **Fiebelkorn, M.** Die Braunkohlenablagerungen zwischen Weissenfels und Zeitz. *Zeitschr. prakt. Geol.*, bd. iii, pp. 353-364. [1895.]
2277. ——— Zur Systematik der Braunkohlen zwischen Weissenfels und Zeitz und zur Entstehung des Pyropisits. *Ibid.*, pp. 496, 497. [1895.]
2278. **Field, A. M.** A New Volcanic Island off Arakan (Bay of Bengal). *Nature*, vol. lxxv, p. 414. [1907.]
2279. **Field, F.** On the Paraffine Industry. *Amer. Chem.*, vol. v, pp. 169-175. [1875.]
2280. **Field, F. W.** Canada. Production of Natural Gas. *Board of Trade Journ.*, vol. lxviii, pp. 34, 35 [1910.]
2281. **Field, L.** Solid and Liquid Illuminating Agents. *Cantor Lectures*, vol. i, 1883.
2282. **Figari, A.** Studi scientifici sull' Egitto e sue adiacenze compresa la Penisola dell' Arabia Petraea. *Map. Lucca*, 1864, 1865.
2283. **Figari, A., and A. H. Husson.** Extrait d'un voyage géologique à Gebel Zeyt et dans le désert compris entre le Nil et la Mer Rouge, depuis le Parallèle du Caire, jusqu'à Kourousko en Nubie. *Bull. Soc. Géogr. Paris*, sér. 3, t. iii, pp. 353-357; t. v, pp. 32-40; t. vi, pp. 111-127, 248-267. [1845, 1846.]
- Filemonowicz, J., see Pawlewski, B.**
2284. **Filipuzzi, F.** Della Paraffina. *Sitz. k. Ak. Wiss. Wien*, bd. xvii, pp. 425-456. [1855.]
2285. **Filiti, G. A.** Sur le dosage du soufre dans les pétroles de Roumanie. *Bull. Soc. Chim. Paris*, sér. 3, t. xxi, pp. 338-341. [1899.]
- Filiti, G. A., see Edeleanu, L.; and Mircea, C. R.**
2286. **Fils, W.** Mitteilungen über Fabrikation von Mineral-schmierölen. *Petroleum Zeitschr.*, bd. v, pp. 1165-1169. [1910.]
2287. **Fiach, J.** Discovery of Retinasphaltum in the Independent Coal Formation [Staffordshire]. *Quart. Journ. Sci. Lett. Arts*, vol. xi, p. 221. [1821.]
- Fink, L., see Klauudy, J.**
2288. **Fink, W.** Der Flysch im Tegernseer Gebiet, mit spezieller Berücksichtigung des Erdölorkommens. *Geogn. Jahresh. Münch.*, bd. xvi, pp. 77-104, pl. [1905.]
2289. ——— Zur Flysch-Petroleumfrage in Bayern. *Zeitschr. prakt. Geol.*, bd. xliii, pp. 330-333. [1905.]
2290. **Finkener, —.** Kaukasisches Petroleum. *Mith. k. techn. Versuchsanst.*, bd. i, p. 126. [1883.]
2291. ——— Nachweisung von Mineralöl in Harzöl. *Ibid.*, bd. iii, p. 160. [1885.]
2292. ——— Nachweis von Mineralölen in fetten Oelen. *Ibid.*, bd. iv, pp. 13, 14. [1886.]
2293. ——— Ueber die Feststellung der Temperatur, bei der Ceresin und Paraffin ihren Aggregatzustand ändern. *Ibid.*, bd. xvii, pp. 100-103. [1899.]
2294. **Finlayson, A. M.** Labour on the Burmese Oilfields. *Mining Mag.*, vol. vi, pp. 137-140. [1912.]
- Fin, C. P., see Cohea, J. B.**
2295. **Fischer, —.** Oryctognosia. 1820.
2296. **Fischer, —.** Vorkommen, Gewinnung und Entstehung des Erdöls. *Wochenschr. Ver. deutsch. Ing.*, 1881, pp. 247-249.
2297. **Fischer, E.** [Oil-well Casing.] *Monit. Int. Pétrol. Roum.*, t. vi, pp. 817-819. [1905.]
2298. **Fischer, F.** Zur Kenntniss des Erdöles. *Chem. Centr.*, f. 3, bd. ix, pp. 537-542, 553-557. [1878.]
2299. ——— Apparat zur Bestimmung der Verbrennungswärme. *Ber. deutsch. chem. Ges.*, bd. xii, pp. 1694-1696. [1879.]
2300. ——— Ueber die Untersuchung von Schmierölen. *Polyt. Journ.*, bd. ccxxxvi, pp. 487-497. [1880.]
2301. **Fischer, F.** Zur Entstehung von Bränden in Benzolwäschereien und durch Leuchtgas. *Zeitschr. angew. Chem.*, bd. i, pp. 138-141. [1888.]
2302. ——— Die chemische Technologie der Brennstoffe. *Svo, Brunswick*, 1897-1901.
2303. ——— Apparat zur Bestimmung des Schwefels im Leuchtgas. *Zeitschr. angew. Chem.*, bd. x, pp. 302, 303. [1897.]
- Fischer, F., see Höfer, H.**
2304. **Fischer, G.** Zur Reinigung von gebrauchter Schmierölen. *Ind. Blatt.* [1887.]
2305. **Fischer, H., and D. Rüst.** Ueber das mikroskopische und optische Verhalten verschiedener Kohlenwasserstoffe, Harze, und Kohlen. *Zeitschr. Kryst. Min.*, bd. vii, pp. 209-233, pl. [1884.]
2306. **Fischer, M.** Natural Gas in Kentucky. *Amer. Manuf.*, Natural Gas Suppl., 1887.
2307. ——— The Oil-field of Barren County, Ky. *Eng. Min. Journ.*, vol. xlix, pp. 197, 198. [1890.]
2308. **Fischer, T.** Der Erstarrungsgrad von Paraffin. *Zeitschr. angew. Chem.*, bd. xix, pp. 1323-1326. [1906.]
2309. **Fishback, P. J.** Geological Horizon of the Petroleum in south-east Texas and south-west Louisiana. *Eng. Min. Journ.*, vol. lxxiv, p. 476. [1902.]
2310. **Fisher, C. A.** Mineral Resources of the Bighorn Basin [Wyoming]. *Bull. U. S. Geol. Surv.*, no. 285, pp. 311-315. [1906.]
2311. ——— Geology and Water Resources of the Bighorn Basin. *Prof. Papers U. S. Geol. Surv.*, no. 53. Pp. 72; 16 pls. [1907.]
2312. ——— Nepesta, Colo. *Fo. 135, U. S. Geol. Surv.* [1906.]
2313. **Fisher, R.** The Coal-fields of Labuan, Borneo. *Trans. Fed. Inst. Min. Eng.*, vol. vii, pp. 587-600. [1894.]
2314. **Fisher, W. E., and E. B. Wood.** Some Experiments on Diesel Engine. *Proc. Inst. Civ. Eng.*, vol. clxxxix, pp. 346-363. [1909.]
2315. **Fitz, J.** Das Rohöl als Heizmaterial für Lokomotiven. *Naphta*, bd. xv, pp. 485-488. [1907.]
2316. ——— Mechanische und hydraulische Tiefbohrung. *Ibid.*, bd. xvi, pp. 163-167, 186-188. [1908.]
2317. **Fitzgerald, J. H.** Beaumont Oil for Gas Making. *Proc. Western Gas Assoc.*, 1899-1902, pp. 487-497. [1902.]
2318. **Fitzgerald, W. G.** The Fiery Mountains of Baku. *Cassell's Mag.* [vol. lvi], pp. 600-607. [1902.]
2319. **Flachat, E., and — Noisette.** Note descriptive des expériences faites sur l'application de l'Asphalte coulé sur les planchers des magasins et greniers pour empêcher la propagation de l'incendie. *Mém. Soc. Ing. Civ.*, 1868, pp. 362-370.
2320. **Flachs, A.** [The Bitumen of the Lias Shales of Reutlingen.] *Chem. Ges. Karlsruhe*, 1901.
2321. ——— [Sumatra Petroleum Spirit (Benzine)]. *Allgem. österr. Chem.-Techn.-Zeit.*, bd. xx, p. 3. [1902.]
2322. ——— Zeitgemässe Benzinfragen. *Ibid.*, bd. xxix, pp. 105, 106. [1911.]
2323. **Flannery, J. F.** The Transport of Petroleum in Bulk. *Proc. 2nd Internat. Marit. Congr.*, sect. B, pp. 62-82. [1893.]
2324. ——— On Liquid Fuel for Ships. *Trans. Inst. Naval Arch.*, vol. xlii, pp. 53-75, pls. iii, iv. [1902.]
- Flannery, J. F., see Terry, S. H.**
2325. **Flaunet, C.** Les pétroles italiens. *Monit. Prod. Chim.*, ann. xxv, no. 18, p. 1. [1895.]
2326. **Fleischer, J.** Trichteransatz zur Paraffinbestimmung in Mineralölestillaten. *Chem.-Zeit.*, bd. xxix, p. 489. [1905.]
2327. **Fleming, A.** A Report on the Salt Range in the Punjab, and on its Coal and Other Minerals. *Journ. As. Soc. Beng.*, vol. xvii, pt. 2, pp. 500-526. [1848.]
2328. ——— Report on the Geological Structure and Mineral Wealth of the Salt Range in the Punjab. *Ibid.*, vol. xxii, pp. 229-279, 333-368, 444-462. [1853.]

2329. **Fleming, S.** Notes on the Present Condition of the Oil Wells of Enniskillen. *Canad. Journ.*, n.s., vol. viii, pp. 246-249. [1863.]
2330. **Fletcher, H.** Report on the Geology of Northern Cape Breton. *Rep. Geol. Surv. Canada*, 1882-1884, H., pp. 98. [1885.]
2331. **Flett, J. S.**, see **Cadell, H. M.**
2332. **Flouriau de Bellevue.** — Sur un Carbone terreux cristallisé, qui doit être regardé comme un variété de l'antracite. *Journ. Mines*, t. ix, pp. 399-405. [1799.]
2333. **Flicher.** — [Power in Oil-raising.] *Pétrole, Mines et Industrie*, t. i, no. 6, p. 4. [1906.]
2334. **Flores, E. M.** Contribucion al Estudio de la Genesis de los Aceites Minerales por las Propiedades del de Oran. Provincia de Salta, Republica Argentina. *An. Soc. Cient. Argent.*, t. lxxix, pp. 61-99. [1910.]
2335. **Flores, T.** Consideraciones generales[s] sobre el uso de Motores de Gasolina en las Minas. *Mem. Soc. Ci. Atzate*, t. xxii, pp. 79-86, pl. iv. [1905.]
2336. **Flurl, M. v.** Einige Notizen über das Vorkommen des Brandschiefers und die Benützung desselben zur Gewinnung von Steinöl in der Gegend von Seefeld. *N. Jahrb. Berg-Hüttenk.*, bd. iii, pp. 196-203. [1815.]
2337. **Flusin, G.** Sur l'osmose des liquides à travers une membrane de caoutchouc vulcanisé. *Compt. Rend.*, t. cxxvi, pp. 1497-1500. [1898.]
2338. **Fock.** — Ueber Explosionen von Petroleumlampen. *Sitz. Ver. Beford. Gewerblf.* 1887, pp. 70-78.
2339. **Fodera, O.** Distretto di Napoli. *Rel. Serv. Min.*, 1880, pp. 231-243. [1883.]
2340. **Foderé.** — Notice sur une fontaine contenant du gaz hydrogène sulfuré et carboné, qui est située sur les bords du Rhin, au moulin de Rhinan, avec quelques réflexions sur la gazification des eaux. *Journ. Soc. Sci. Strasb.*, t. iii, pp. 182-188. [1826.]
2341. **Förster.** — Geologisches Führer für die Umgebung von Mühlhausen. [1892.]
2342. **Förster, F.**, see **Mylius, F.**
2343. **Fötterle, F.** [Dalmatian and Istrian Rocks and Fossils.] *Jahrb. k.-k. geol. Reichs.*, bd. ii, pt. 4, pp. 137-140. [1852.]
2344. — [Seefeld Asphalt Works.] *Ibid.*, bd. vii, pp. 196, 372. [1856.]
2345. — Ueber das Vorkommen von Naphta (Erdöl) im Sandecr und Jaslo'er Kreise, West Galiziens. *Verh. k.-k. geol. Reichs.*, 1859, pp. 183, 184.
2346. — [Liassic Coal-bearing Series in the Banat.] *Ibid.*, 1862, pp. 214, 215.
2347. — Das Vorkommen von Asphalt am Colle della Pece bei Pofi-Castro in Mittel-Italien. *Ibid.*, 1872, pp. 347-351.
2348. **Foley, W.** Journal of a Tour through the Island of Ramree, with a Geological Sketch of the country, *Journ. As. Soc. Beng.*, vol. iv, pp. 20-38, 82-94, 199-206. [1835.]
2349. **Folger, H. C., jun.** Petroleum; its Production and Products. *Ann. Rep. Bureau Industr. Statist. Penns., Harrisburg, Pa.* 1893.
2350. **Fontaine, W. M.** Notes on the West Virginia Asphaltum Deposit. *Amer. Journ.*, ser. 3, vol. vi, pp. 409-416. [1873.]
2351. **Fontaine, W. M.**, see **Hale, J. P.**
2352. **Fonvielle, W. de.** Le Pétrole. 8vo, Paris, 1888.
2353. **Foot, A. E.** Discovery of Petroleum in Pennsylvania. *Amer. Chem.*, vol. iii, p. 174. [1873.]
2354. **Forbes, E.**, and **T. A. B. Spratt.** On the Geology of Lycia. *Quart. Journ. Geol. Soc.*, vol. ii, pp. 8-11. [1840.]
2355. **Forbes, E.**, see **Spratt, T. A. B.**
2356. **Forchhammer, G.** [Substances resembling Scheererite from Danish Peat-bogs.] *Afh. k. Dansk. Vid. Selsk.*, rk. 4, bd. viii, pp. lxxxix-xciii. [1840.]
2357. — Foredrag over de forandringar, som terpentinolien eller en dermed isomere forbindelse har lidt i Törvemoserne. *Forh. Skand. Naturf.*, bdt. ii, pp. 256-264. [1840.]
2358. **Ford, H. C.** Specimens of Coniferous Wood saturated with Bitumen. *Bull. Sta. Barbara Nat. Hist. Soc.*, vol. i, p. 11. [1891.]
2359. **Ford, H. T.** Discovery of Bitumen on Bearwood Hill. *Mid. Nat.*, vol. iii, p. 72. [1880.]
2360. **Fordred, J., F. Lambe, and C. Sterry.** Traitement des hydrocarbures et de la paraffine. *Gén. Ind.*, t. xxxvii, pp. 156-158. [1864.]
2361. **Forrest, C. N.** A further Development of the Penetrator as used in the Determination of the Consistency of Semi-Solid Bitumens. *Proc. Amer. Soc. Test. Mat.*, vol. ix, pp. 600, 601. [1909.]
2362. **Forrest, C. N.**, see **Richardson, C.**
2363. **Forrest, L. R.**, see **Gill, A. H.**
2364. **Forsselles, A.** Om Naftaeldning. *Tekn. Tidskr.*, bt. xxx, sect. K, pp. 79-82. [1900.]
2365. — Några anteckningar om fordringarna på gultermateriel. *Ibid.*, bt. xxxi, sect. K, pp. 92, 93. [1901.]
2366. **Forshey, C. G.** Report of Survey and Borings made at the Proposed Site of the Lake Borgue outlet, 44th Congr., 1st Sess., *Rep. Sec. War. Eng. Dept.*, vol. ii, pt. 1, pp. 622-629. [1875.]
2367. **Forstall, A. E.** The Origin of Coal and Petroleum. *Amer. Gas-Light Journ.*, vol. lvi, pp. 885-887. [1892.]
2368. **Forsten, E. A.** Responso ad questionem chemicam "Exponatur aetheris et naphtharum, tum reliquarum ex actione acidorum in alcoholum productarum materierum, historia chemica, ratio, natura et usus." *Ann. Acad. Lugd. Batav.* [1832.]
2369. **Forster, G.** Journey from Bengal to England, through the Northern Part of India, Kashmir, Afghanistan, and Persia, and into Russia, by the Caspian Sea. 2 vols. 4to, London, 1798.
2370. **Forstner, E. M.** The Use of Petroleum for Power Purposes. *Min. Sci. Press*, vol. lxxxiv, pp. 130, 131. [1902.]
2371. **Forstner, W.** Oil Measures in the Coalinga district [California]. *Min. Sci. Press*, vol. xcvi, pp. 386, 387. [1905.]
2372. — Geology of the Coalinga Oil district. *Ibid.*, vol. xcix, pp. 566, 567. [1909.]
2373. — Acquisition of Public Oil Lands. *Ibid.*, vol. ci, pp. 171-173. [1910.]
2374. — Occurrence of Oil and Gas. *Ibid.*, pp. 634-637. [1910.]
2375. — The Oil Industry and Public Lands in California. *Ibid.*, vol. ciii, pp. 316, 317. [1911.]
2376. — The Valuation of Oil Lands. *Ibid.*, pp. 578-580. [1911.]
2377. — The Occurrence of Oil and Gas in the South Midway Field, Kern Co., California. *Econ. Geol.*, vol. vi, pp. 138-155. [1911.]
2378. — The Oil Industry of California. *Mining Mag.*, vol. v, pp. 291-294. [1911.]
2379. **Fortey, E. C.** Hexamethylene from American and Galician Petroleum. *Journ. Chem. Soc.*, vol. lxxiii, pp. 932-949. [1893.]
2380. **Fortey, E. C.**, see **Young, S.**
2381. **Fortin, E.** Une plaine de bitume au Vénéziéda. *Compt. Rend. Soc. Géogr. Paris*, 1895, pp. 221-224.
2382. **Fortis, A.** Viaggio nella Dalmatia. . . English, 4to, London, 1778.
2383. **Fortis, F.** Salso, lo sne saline, e suol establimentil. *Politecnico*, vol. ix, pp. 510-512. [1860.]
2384. **Foster, C. L. N.** Notes on the Van Mine [Montgomeryshire, Wales]. *Trans. R. Geol. Soc. Cornwall*, vol. x, pt. 2, pp. 33-46, pls. li-v. [1880.]
2385. **Foster, C. L. N.**, see **Green, A. H.**
2386. **Foster, E. H.** A Russian Petroleum Pipe Line carrying Oil from Baku to Batoum. *Cassier's Mag.*, vol. xix, pp. 1-16. [1900.]
2387. **Foster, W.** On the Effects of Specific Hydrocarbon on the Lighting Value of Combustible Gas. *Trans. Gas. Inst.*, 1891, pp. 71-83.
2388. **Foucault, Th.** Les Gisements de Pétrole en Roumanie; leur avenir. *Technol.*, sér. 3, t. iii, pp. 276-278. [1880.]

2381. **Foucau, F.** Sur le Gisement de Pétrole des Karpathes. *Mém. Soc. Ing. Civ.*, 1865, pp. 317-325, 416, 417, 425, 426.
2382. ——— [Occurrence and Exploitation of Petroleum in North America, with theories as to its origin.] *Ibid.*, 1867, pp. 82-86.
2383. ——— Sur les Gisements de cinq séries de Gaz Hydrocarbonés provenant des roches paléozoïques de l'Amérique du Nord. *Compt. Rend.*, t. lxvii, pp. 1011-1045. [1868.]
2384. ——— Le Pétrole et les hommes d'huile de l'Amérique du Nord. *Rev. deux Mondes*, 15th April, 869.
2385. **Fougeroux de Bondaroy, A. D.** Premier Mémoire sur la pétrole de Parme. *Hist. Acad. Roy. Sci.*, 1770, *Mém.*, pp. 37-44.
2386. ——— Second Mémoire sur le pétrole et sur des vapeurs inflammables communes dans quelques parties de l'Italie. *Ibid.*, pp. 45-52.
2387. **Foullon, H. v.** Vorlage von Mineralien—Steinsalz auf und in Ozokerit von Truskawice. *Verh. k.-k. geol. Reichs.*, 1888, p. 94.
- Foullon, H. v.**, see **John, C. v.**
- Fouque**, —, see **Gossiaux**, —.
2388. **Fouqué, F.** Étude chimique des cinq Gaz des Sources de Pétrole de l'Amérique du Nord. *Compt. Rend.*, t. lxvii, pp. 1045-1049. [1868.]
2389. **Fouqué, F.**, and **H. Gorceix.** Étude chimique de plusieurs des Gaz à éléments combustibles de l'Italie centrale. *Compt. Rend.*, t. lxxix, pp. 946-950. [1869.]
2390. ——— Recherches sur les sources de Gaz inflammables des Apennins et des lagoni de la Toscane. *Ann. Sci. Géol.*, t. ii, no. 1, pp. 102. [1870.]
- Fouqué, F.**, see **Sainte Claire Deville, C. J.**
2391. **Fourcroy, A. F.** Système des Connaissances Chimiques et de leurs applications aux Phénomènes de la Nature et de l'Art. 10 Tt. 8vo. Paris, 1800.
2392. **Fournel**, —. Emploi, chez les anciens, de l'huile de pétrole dans le traitement de la gale. *Compt. Rend.*, t. ix, p. 217. [1839.]
2393. **Fournel, H.** Description of the Asphaltic Mine of the Val de Travers, in the Canton of Neuchâtel. With introductory observations by the Count de Sassenay, and Remarks on the Works executed by the Seyssel and other companies in Paris, etc., by P. Muldoon. 8vo. London, 1835.
2394. **Fournet, J.** Sur les huiles de pierre. *Ann. Soc. Agric. Lyon*, t. iii, pp. xv-xviii. [1859.]
2395. **Fox, H. H.** Memorandum on Chinese Mines. *Dipl. Cons. Rep.*, misc. ser., no. 680. [1911.]
2396. **Fox, W.** Action of Petroleum on Lead. *Chem. News*, vol. lviii, p. 39. [1888.]
2397. **Fox, W. G.** German Petroleum and Petroleum Wells. *Rep. Cons. U.S.*, vol. iii, pp. 407, 408. [1881.]
2398. **Fraas, O.** Die nutzbaren Mineralien Württembergs. 1860.
2399. ——— Aus dem Orient. Geologische Beobachtungen am Nil, auf der Sinai-Halbinsel und in Syrien. 8vo. Stuttgart, 1867.
2400. ——— [Origin and Formation of Bitumen and Asphalt.] *Bull. Soc. Sci. Nat. Neuchâtel*, t. viii, pp. 58-61. [1868.]
2401. ——— Geologisches aus dem Libanon. *Jahresh. Ver. Nat. Württ.*, bd. xxxiv, pp. 257-391, 6 pls. [1878.]
2402. ——— Geognostischer Beschreibung von Württemberg, Baden, und Hohenzollern. 8vo. Stuttgart, 1882.
2403. **Fraenkel, N.** The Manufacture of Ceresine from Ozokerite. *Min. Industry*, vol. iv, pp. 510-512. [1895.]
- Franché, G.**, see **Tettedou, P.**
2404. **Francis, E.** Timor in 1831. *Tijdschr. Ned. Ind.*, dl. i, h. 2, pp. 362-365, 387. [1838.]
2405. **Francis, E. E. H.** On a Chemical Examination of Specimens from the recently-discovered Coal Deposits at Williamsville and Montserrat. *Proc. Sci. Assoc. Trinidad*, vol. ii, pp. 125-134. [1877.]
2406. **Francis, J. E.**, and **S. Young.** Separation of Normal and Iso-heptane from American Petroleum. *Journ. Chem. Soc.*, vol. lxxiii, pp. 920-922. [1895.]
2407. ——— The Action of Fuming Nitric Acid on the Paraffins and other Hydrocarbons. *Ibid.*, pp. 928-932. [1898.]
2408. **Franco y Munoz, J.** Memoria acerca del aprovechamiento industrial de las sustancias bituminosas de origen mineral que hay en la Peninsula. 1872.
- François, D.**, see **Frézon-Dumont, E.**
2409. **François, P.** [Petroleum in Austria.] *Monit. Int. Petrol. Roum.*, t. iii, pp. 406-410. [1902.]
2410. **Frank, A.** Der Zoll für schwere Mineralie und die Gasindustrie. *Zeitschr. angew. Chem.*, bd. xv, pp. 237, 238, 497, 498. [1902.]
2411. **Frank, G.** Handbuch der Bricketbereitung. 8vo. Stuttgart, 1909.
2412. **Frankenheim, M. L.** Die Ausdehnung einiger flüssigen Körper durch die Wärme. *Ann. Chem. Phys.*, bd. cxlviii, pp. 422-431. [1841.]
2413. **Frankland, E.** On Artificial Illumination. *Proc. Roy. Inst.*, vol. iv, pp. 16-23. [1863.]
2414. **Frankland, P. F.** The Illuminating Power of Ethylene when burnt with Non-luminous Combustible Gases. *Journ. Chem. Soc.*, vol. xiv, pp. 30-40, 227-237. [1884.]
2415. ——— The Illuminating Power of Hydrocarbons. *Ibid.*, vol. xlvii, pp. 235-240. [1885.]
2416. **Franklin, B.** After Petroleum. *Harper's Mag.*, vol. xxx, p. 53. [1864.]
2417. **Franklin, J.** Narrative of a Second Expedition to the Shores of the Polar Sea, in the Years 1825, 1826, and 1827, including an Account of the Progress of a Detachment to the Eastward, by John Richardson. 2 vols. 4to. London, 1828.
2418. **Frantov**, —. [Sketch of the Oil Industry in America and the Caucasus.] *Priroda & Okhota*, nos. 11 and 12, 1878.
- Frasch, G.**, see **Zaloziecki, R.**
2419. **Frasch, H. A.** Asphaltum Refining. *Min. Industry*, vol. vii, pp. 75-86. [1898.]
- Fraser, A.**, see **Robertis, R. W.**
2420. **Fraser, D. D.** Report for 1893 on the Trade of the Island of Java. *Dipl. Cons. Rep.*, ann. ser., no. 1328. [1894.]
2421. ——— Report for the year 1895 on the Trade of Samarang (Java). *Dipl. Cons. Rep.*, ann. ser., no. 1722. [1896.]
2422. **Fraser, H.** Reports for 1893 on the Trade of Yokohama, Hirogo and Osaka. *Dipl. Cons. Rep.*, ann. ser., nos. 1421, 1459. [1894.]
2423. **Fraser, L.** Mineral Resources of Costa Rica. *Min. Sci. Press.*, vol. cii, pp. 130-132. [1911.]
2424. **Frassonni, A.** De Therमारum Montis Gibil Natrâ Usu atque Praestantiâ. 8vo. Modena, 1609.
2425. **Frazer, P., jun.** Mines and Minerals of Colorado. *First, Second and Third Ann. Reports U.S. Geol. Surv. Territories* (reprint), pp. 201-251. [1873.]
2426. **Freeman, E. B.** Report for 1888 on the Trade of Bosnia and Herzegovina. *Dipl. Cons. Rep.*, ann. ser., no. 596. [1889.]
2427. **Freise, F.** Geographische Verbreitung und wirtschaftliche Entwicklung des Bergbaues in Vorder- und Mittelasien während des Altertums. *Zeitschr. prakt. Geol.*, bd. xv, pp. 101-117. [1907.]
2428. **Frenzel, A.** Mineralogisches aus Kaukasien. *Min. petr. Mitth.*, bd. ii, pp. 125-136. [1879.]
2429. **Frese, H.** Ueber das Vorkommen von  $\alpha$ -Pikolla im Braunkohlenterr. *Zeitschr. angew. Chem.*, bd. xvi, pp. 11, 12. [1903.]
2430. **Fresenius, C. R.** Untersuchung einiger Braunkohlen des Westerwaldes in Hinsicht auf die Produkte welche sie bei der trockenen Destillation liefern. *Polyt. Journ.*, bd. cxxxviii, pp. 129-140. [1855.]
2431. **Fresenius, R.** Zur Kenntniss der Vaseline. *Ibid.*, bd. cxxxvi, p. 503. [1880.]
- Freson**, —, see **Demaret**, —.
2432. **Frey, H. C.** Rapid Determination of Petroleum Naphtha in Turpentine. *Journ. Amer. Chem. Soc.*, vol. xxx, p. 420. [1908.]

- Freycinet, L., see Peron, F. A.
2433. Freystedt, A. Oelheim. Ein Beitrag zur Kenntniss des Erdölorkommens in Norddeutschland. *Beitr. Geol. Pal. Braunschwe.*, bd. i, pp. 101-194; 4 pls. [1894.]
2434. Freytag, F. Die Weltausstellung in Paris 1900. Explosionsmotoren. *Zeitschr. Ver. deutsch. Ing.*, bd. xlv, pp. 1077-1080, 1673-1680; bd. xiv, pp. 53-61, 109-118, 325-332, 615-620, 657-663, 988-993, 1063-1066, 1693-1701. [1900, 1901.]
2435. Frezin, —. Sur un dégagement d'Hydrogène Carboné observé dans une localité de la Vallée de l'Arve [Châtillon, Haute-Savoie]. *Compt. Rend.*, t. xli. pp. 410, 411. [1855.]
2436. Frézon-Dumont, E., and D. François. Nouvelle Transformation de l'huile de pétrole. *Corps Gras Ind.*, t. viii, pp. 240, 241. [1882.]
2437. Friedborg, W. [Miocene of Rzeszow.] *Rozpr. Ak. Umiej. Krakow*, t. xvi, A, pp. 103-128. [1906.]
2438. Friedel, C., and J. M. Crafts. Sur une nouvelle méthode générale de synthèse d'hydrocarbures, d'actones, etc. *Compt. Rend.*, t. lxxxiv, pp. 1392-1395, 1450-1454; t. lxxxv, pp. 74-77. [1877.]
2439. —. Sur une méthode d'analyse applicable à des mélanges d'hydrocarbures de la série aromatique. *Ibid.*, t. ci, pp. 1218-1223. [1885.]
2440. Friedenthal, H. Ueber quantitative chemische Analyse von Gemenge mit Anwendung der Differenzen in spezifischen Gewichten. *Ber. deutsch. chem. Ges.*, bd. xlv, pp. 901-908. [1911.]
2441. Friedländer, H. The Country of Earth-oil in Upper Burma. *Burma Gazette*, 1874.
2442. Friedländer, S. Ueber die Methoden, den Schwefelgehalt des Petroleum zu bestimmen. *Chem. Ind.*, bd. xxii, pp. 343-349. [1899.]
2443. —. Zur Bestimmung des Schwefels im Petroleum. *Arb. Kais. Ges.-A.*, bd. xv, pp. 365-372. [1899.]
2444. Friedrich, G. W. Von den Napthen und versästen Geistern. *Jahrb. Pharm.*, bd. vii, pp. 62-89. [1801.]
2445. Fries, —. Vorkommen von Petroleum in der Provinz Hannover. *Polyt. Zeit.*, 1874, no. 22.
2446. Friese, W.] Rohes Petroleum als Brennmaterial für Locomotiven. *Polyt. Journ.*, bd. cexv, p. 131. [1877.]
2447. —. Erdölfeuerung für Locomotiven. *Ibid.*, bd. cclxxvii, pp. 30, 31. [1893.]
2448. —. Ueber den Wert von Bitumenbestimmungen im Mastix und Stampfasphalt. *Asphalt-Teerind.-Zeit.*, bd. vi, pp. 108, 109. [1906.]
2449. —. Die Asphalt- und Teerindustrie. Eine Darstellung über die Eigenschaften, Gewinnung und Verwertung der natürlichen und künstlichen Asphalte. *Hanover*, 1908.
2450. —. Der Holzzement und seine Beziehungen zum natürlichen Asphalt. *Asphalt-Teerind.-Zeit.*, bd. viii, pp. 335, 336, 353, 354. [1908.]
2451. —. Die Eigenschaften komprimierter Asphalte. *Ibid.*, bd. xi, pp. 379, 399, 400. [1911.]
2452. —. Die bituminösen Zusätze der Asphaltprodukte. *Ibid.*, pp. 459, 479. [1911.]
2453. Friesleben, —. Briefliche Mittheilungen über erlignite Braunkohle. *N. Jahrb.*, 1847, p. 152.
2454. Fritsche, A. Ueber die Fauna der Gaskohle des Pilsner und Rakonitzer Beckens. *Sitz. k. böhm. Ges. Wiss.*, 1875, pp. 70-79.
2455. —. Zur Fauna der Gaskohle von Zabor bei Schlan, Kroncova bei Renc und Tremosna bei Pilsen, sowie über die Sphärosideritkugeln von Zilov. *Ibid.*, 1877, pp. 45-52.
2456. —. Neue Uebersicht der in der Gaskohle und den Kalksteinen der Permformation in Böhmen vorgefundenen Thierreste. *Ibid.*, 1879, pp. 184-195.
2457. Fritzsche, C. J. Ueber Ozokerit, Neft-gil und Kir. *Bull. Ac. Sci. Imp. St. Petersb.*, t. xvi, pp. 241-258. [1858.]
2458. —. Sur quelques nouveaux carbures d'hydrogène. *Compt. Rend.*, t. lxxvii, pp. 1105, 1106. [1868.]
2459. Fritzsche, C. J. Note sur l'antracène de M. Berthelot. *Bull. Ac. Sci. Imp. St. Petersb.*, sér. 2, t. xii, pp. 125-151. [1868.]
2460. —. Mittheilungen über Kohlenwasserstoffe. *Ibid.*, t. xiii, pp. 143-168, 531-548. [1869.]
2461. Frochot, —. Les Pétroles dans l'Amérique du Sud. *Compt. Rend. Soc. Industr. Min.*, 1907, pp. 37-53.
- Frolov, A., see Pastukhov, M.
2462. From, G. B. Oil Burners as used on the River Volga. *Trans. Inst. Marine Eng.*, vol. ix, no. 67. Pp. 50. [1897.]
2463. Frucht, J. [Use of Crude Oil as Fuel.] *Montan. Zeit. Oesterr. Ung. Balkanl.*, bd. xv, pp. 45, 46. [1908.]
2464. Fruh, J. J. Ueber Torf und Dopplerit. Eine mineralogische Studie für Geognosten, Mineralogen, Forst- und Landwirthe. 8vo, Zürich, 1883.
2465. Fryer, J. New Account of India and Persia; being nine years' travels, begun 1672, and finished 1681. Fo, London, 1698.
2466. Fuchs, —, and — Schiff. Ueber Petrolsäuren. *Chem.-Zeit.*, bd. xix, pp. 1469, 1470. [1895.]
2467. Fuchs, C. W. C. Bericht über die vulkanischen Ergebnisse des Jahres 1876. *Min. Mitt.*, 1877, pp. 83-94.
2468. Fuchs, E., and L. de Launay. Traité des Gîtes minéraux et métallifères. 8vo, Paris, 1893.
2469. Fuchs, E., and E. Sarasin. Notes sur les Sources de l'huile de Campina (Valachie). *Arch. Sci. Phys. Nat.*, sér. 5, t. xvi, pp. 89-113. [1873.]
2470. Fuchs, J. Der Ozokerit (Erdwachs) und dessen Verwendung. *Brest. Geueber-R.*, bd. xi, p. 202. [1865.]
2471. Fuchs, J. N. v. Gesammelte Schriften. 8vo, Munich, 1856.
2472. Fuchs, K. Erfahrungen aus der Praxis [der Mineralödestillation]. *Chem. Rev. Fett- Harz- Ind.*, bd. xiii, p. 187. [1906.]
2473. Fuchs, Th. Ueber die Natur des Flysches. *Sitz. k. Ak. Wiss. Wien*, bd. lxxv, pp. 340-362. [1877.]
2474. —. Die Salse von Sassuolo und die Argille scagliose. *Ibid.*, bd. lxxvi, pp. 231-239. [1878.]
2475. —. Ueber den Flysch und die Argille scagliose. *Ibid.*, pp. 462-466. [1878.]
2476. —. Zur Flyschfrage. *Verk. k.-k. geol. Reichs.*, 1878, pp. 135-142.
2477. Fürer, F. A. Salzbergbau und Salinenkunde. 8vo, Brunswick, 1900.
2478. Fuhst, H. Beschreibung einer Waschmaschine für Minerale. *Polyt. Journ.*, bd. clxvi, pp. 21-24. [1862.]
2479. —. Ueber die continuirliche Destillation des Petroleum der Minerale, etc., bei constantem Niveau und fractionirter Cocondensation. *Ibid.*, bd. ccvii, pp. 293-304. [1873.]
2480. Fuller, Myron L. The Gaines Oil Field of Northern Pennsylvania. *Ann. Rep. U. S. Geol. Surv.*, vol. xxii, pt. 3, pp. 579-627, pls. xxxvi-xliii. [1901.]
2481. —. Asphalt, Oil and Gas in South-western Indiana. *Bull. U. S. Geol. Surv.*, no. 213, pp. 333-335. [1903.]
2482. —. Hyner Gas Pool, Clinton County, Pa. *Ibid.*, no. 225, pp. 392-395. [1904.]
2483. Fuller, M. L., and W. C. Alden. Gaines (Penn.). Fo. 92, *U. S. Geol. Survey*, 1903.
2484. Fuller, M. L., and G. H. Ashley. Ditney (Indiana). Fo. 84, *Id.*, 1902.
2485. Fuller, M. L., and F. G. Clapp. Patoka (Indiana). Fo. 105, *Id.*, 1904.
2486. Fuller, M. L., E. F. Lines, and A. C. Veatch. Records of Deep Well Drilling for 1904. *Bull. U. S. Geol. Surv.*, no. 264. Pp. 106. [1905.]
2487. Fuller, M. L., and S. Sanford. Record of Deep Well Drilling for 1905. *Bull. U. S. Geol. Surv.*, no. 298. Pp. 299. [1906.]
2488. Fulweller, W. H. A New Machine for Testing the adhesive quality of Pitch. *Chem. Eng.*, vol. xii, p. 14. [1910.]

2489. **Fyfe, A.** On the Manufacture of hydrocarbon Coal-gas from Boghead Coal. *Journ. Franklin Inst.*, vol. xxiv, pp. 347-353, 399-405. [1852.]
2490. ——— On the Composition and Properties of Coal, and the Products of its Distillation. Is Torbane Mineral a Coal? *Trans. R. Scott. Soc. Arts*, vol. iv, pp. 250-256. [1856.]
2491. **G——, A.** Pour obtenir économiquement un bon Eclairage au Pétrole. *Journ. Pétrol.*, t. vii, pp. 17-20. [1907.]
2492. **G——, G.** Die Bedeutung des Bohrloches von Goczalkowitz. *Montan. Zeit. Oesterr. Ung. Balkanl.*, bd. xiii, pp. 379, 380. [1906.]
2493. **G——, H.** Die ersten praktischen Resultate auf dem ung. Petroleumbergangebiets. *Ung. Montanind. Zeit.*, 1886.
2494. **G——, O.** Versuch mit Asphaltstein und Stampf-asphalt. *Asphalt-Teerind.-Zeit.*, bd. v, pp. 352, 353. [1905.]
2495. ——— Teerölheizung auf Schiffen. *Asphalt-Teerind.-Zeit.*, bd. vi, pp. 265, 266. [1906.]
2496. **Gabb, W. M.** On the Occurrence of Petroleum in the Island of San Domingo. *Amer Journ.*, ser. 3, vol. iii, p. 481. [1872.]
2497. **Gabet, E.** Distretto di Caltanissetta. *Riv. Serv. Min.*, 1896, pp. 43-84; 1897, pp. 43-88; 1898, pp. 27-87; 1899, pp. 35-98. [1897-1900.]
2498. **Gabrilowitsch, O. G.** Zur Frage des Extraktionswachsens. *Seifensied.-Zeit.*, bd. xxxvi, pp. 1131, 1132, 1179, 1180. [1909.]
2499. **Gad, E.** Neuerungen in der Tiefbohrtechnik. *Polyt. Journ.*, bd. cclxxi, pp. 289-301, pl. iv. [1889.]
2500. **Gadd, W.** Ueber die Verwendung von Mineralölen zur Erzeugung von Dampf. *Ibid.*, bd. cxviii, pp. 310-314. [1875.]
2501. **Gärtner, S.** Ueber das Paraffin. *Zeitschr. ges. Nat.*, bd. lxxv, pp. 161-163. [1903.]
2502. **Gailardot, C.** [Dead Sea Asphalt.] *Ann. Soc. Emul. Fosges*, t. vi. [1819.]
- Galdi, B.**, see **Camerana, E.**
2503. **Gale, H. S.** Geology of the Rangely Oil District, Rio Blanco County, Colorado. *Bull. U.S. Geol. Surv.*, no. 350. Pp. 61; 4 pls. [1908.]
2504. ——— Coalfields of North-western Colorado and North-eastern Utah. *Ibid.*, no. 415. Pp. 257; 22 pls. [1911.]
2505. **Galeazzi, —.** Iter Bononiâ ad Alces S. Pellegrini. *Comment. Sci. Inst. Bonon.*, t. i, pp. 97-100. [1741.]
2506. **Galen, A.** [Petroleum of the Ukhta (Archangel).] *Eskaterinenburg. Nedielia*, 1892, nos. 11, 12; *Trudi Bak. Old. Imp. Russk. Tekhn. Obsch.*, 1893, Nov.-Dec., pp. 33-36.
2507. **Galine, L.** Traité général d'éclairage: Huile Pétrole, Gaz, Électricité. 8vo, Paris, 1894.
2508. **Gallard, —.** Étude du Pétrole Romain et de ses résidus. *Journ. Pétrol.*, t. iv, pp. 220-222, 243, 244. [1904.]
2509. **Gallety, J.** On a Paraffin having a high melting-point [from Boghead "coal"]. *Chem. News*, vol. xxiv, pp. 187, 188. [1871.]
2510. **Gallizin, D. de.** Recueil de Noms appropriés en Minéralogie aux Terres, Pierres, Métaux et aux Bitûmes. Fo, Brunswick, 1802.
2511. **Galloway, B. T.** Heating Experiments with Oils and Manufactured Gas. *Amer. Gas Light Journ.*, vol. lxxix, pp. 644-646. [1903.]
2512. **Galloway, R. L. A.** Treatise on Fuel, scientific and practical. 8vo, London, 1880.
2513. **Galloway, R. S.** Incandescent Gas Lighting. *Journ. Gaslighting*, vol. lxiv, pp. 238, 239, 329, 330. [1894.]
2514. **Galloway, W.** The Ozokerite Mines and Oil Wells at Boryslaw in Austrian Poland. *Proc. S. Wales Inst. Eng.*, vol. xxiii, pp. 223-234. [1903.]
2515. **Gamba, —.** [Earthquakes and Eruption of New Volcanic Hills near Baku.] *Sieberrn. Archiv*, t. xxxiv, no. 7. [1828.]
2516. **Gan, N. U.** [On the Present Condition of the Baku Industry.] *Zap. Imp. Russk. Tekhn. Obsch.*, g. xxv, Jun., pp. 1-28. [1892.]
2517. **Gandolfi, —.** Lettera sopra il carbon fossile e schisto bituminoso che si trova in Filetino e nelle sue vicinanze. *Rome*, 1689.
- Gané, G.**, see **Edeleanu, L.**
2518. **Gans, L.** Ueber die Nothwendigkeit der Feststellung einheitlicher Untersuchungs-Methoden in der Petroleum-Industrie. *Chem. Rev. Fett-Harz-Ind.*, bd. i, no. 28, pp. 2, 3. [1895.]
2519. ——— Destilliraufsatz für die fractionirte Destillation von Petroleum, etc. *Ibid.*, no. 31, p. 3. [1895.]
2520. ——— Ueber leichtes Camphoröl als Petroleum-zusatz. *Ibid.*, bd. iv, p. 304. [1897.]
2521. ——— Petroleum als Mittel gegen Pflanzenparasiten. *Ibid.*, bd. vi, pp. 14, 15. [1899.]
- Gaus, L.**, see **Zaloziecki, R.**
2522. **Ganswindt, A.** Zur Benzinersatz-Frage. *Zeitschr. angew. Chem.*, bd. xii, pp. 537-540. [1899.]
2523. **Garland, A.** La industria del petroleo en el Peru en 1901. *Bol. Cuerpo Ing. Minas, Peru*, no. 2. [1902.]
2524. **Garrett, F. C.**, and **E. L. Lomax.** Determination of Sulphur in Petroleum and Bituminous Minerals. *Journ. Soc. Chem. Ind.*, vol. xxiv, pp. 1212, 1213. [1905.]
2525. **Garrett, F. C.**, and **J. A. Smythe.** The Bases contained in Scottish Shale Oil. *Journ. Chem. Soc.*, vol. lxxxi, pp. 449-456; vol. lxxxi, pp. 763-765. [1902, 1903.]
- Garrett, T. H.**, see **Booth, J. C.**
2526. **Garry, H. S.**, and **H. J. Watson.** Notes on Petroleum Spirit or Benzine. *Journ. Soc. Chem. Ind.*, vol. xxiii, pp. 701-704. [1904.]
2527. **Garvey, F.** Ueber den Stickstoffgehalt des Bitûmens in seiner Beziehung der Frage der Bildung des Erdöls, Stickstoffbasen des Eisässers Erdöls. Untersuchung eines bituminösen Schieferers aus Texas. Die Producte der trockenen Destillation von Muscheln und von Fischen. 8vo, Heidelberg, 1896.
2528. **Gary, M.** Prüfung von künstlichem Asphalt. *Mith. k. techn. Versuchsanst.*, bd. xv, pp. 74-80. [1897.]
2529. **Gasiorowski, K.** Zur Reform der Naphtagesetzgebung. *Naphta*, bd. xiii, pp. 194-196, 215-217. [1905.]
2530. **Gaster, L.** Lennard's Continuous Distillation Plant. *Petr. Rev.*, vol. i, pp. 465-468. [1899.]
2531. ——— The Condition of the Roumanian Oil Fields. *Ibid.*, vol. vii, pp. 393-396, 421. [1902.]
2532. ——— Modern Methods of Artificial Illumination. *Cantor Lectures*, vol. viii, 1909.
2533. **Gaster, M.** L'Economie et la Sécurité du Pétrole comme Moyen d'Eclairage. *Compt. Rend. Congr. internat. Pétrole*, sess. 3, t. ii, pp. 881, 882. [1910.]
2534. **Gastrell, J. P. H.** Report for 1888 on the Trade of Chicago. *Dipl. Cons. Rep.*, ann. ser., no. 570. [1889.]
- Gatoux, A.**, see **Baudry de Saunier, L.**
2535. **Gattermann, L.**, and **A. E. Lockhart.** Ueber Thionaphten. *Ber. deutsch. chem. Ges.*, bd. xxvi, pp. 2808, 2809. [1893.]
2536. **Gaudrée-Boileau, —.** Rapport sur l'exploitation de l'huile minérale dans l'Amérique du Nord. *Ann. Mines*, sér. 6, t. ii, pp. 95-122. [1862.]
2537. ——— Mémoire sur les pétroles du Canada. *Ibid.*, t. iv, pp. 105-116. [1863.]
2538. **Gaussoin, —.** Yacimiento de petróleo [Canada and Pennsylvania]. *Revista Minera*, t. xxxiv, p. 239. [1883.]
2539. **Gautier, E. F.** Madagascar. Aperçu de géographie Economique. *Bull. Soc. Géogr. Comm.*, t. xvii, pp. 196-204. [1895.]
2540. **Gautier, E. J. A.** Limites de combustibilité par l'oxyde de cuivre au rouge de l'hydrogene et des gaz carbonés dilués de grands volumes d'air. *Compt. Rend.*, t. cxxx, pp. 1353-1360. [1900.]
2541. ——— Gaz combustibles de l'atmosphère. *Ibid.*, pp. 1677-1684; t. cxxxi, pp. 13-18, 86-90, 535-539, 647-652. [1900.]

2542. **Gautier, E. J. A.** Action de l'Hydrogène sur l'Oxyde de Carbone; formation d'Eau et de Méthane. Action de l'eau, au Rouge, sur le même Oxyde. Applications aux Phénomènes Volcaniques. *Compt. Rend. t. cl*, pp. 1383-1388. [1910.]
2543. **Gautier, E. J. A.**, and **P. Clausmann.** Action du Fer et de ses Oxydes, au Rouge sur l'Oxyde de Carbone. Application à quelques Données Géologique. *Ibid.*, p. cil, pp. 16-22. [1910.]
2544. ———. Action des mélanges d'oxyde de carbone et d'hydrogène, ou d'acide carbonique et d'hydrogène, sur les oxydes de fer. *Ibid.*, pp. 355-359. [1910.]
2545. **Gautier, F.** Fabrication du Gaz éclair, au moyen de l'air et des huiles légères de pétrole, avec suppression de toute disposition mécanique. *Mém. Soc. Ing. Civ.*, 1888, t. 2, pp. 19-25.
2546. **Gautier, L.** Emploi du pétrole comme combustible dans l'industrie du fer. *Portef. Econ. des Machines*, t. xvii, pp. 42-46. [1902.]
2547. **Gautesen, H.** Emploi de la Paraffine. *Journ. Eclair. Gaz.*, t. xix, p. 187. [1871.]
- Gavala, J.**, see **Loygorit**, —
- Gavrilov, S.**, see **Schnkov, V.**
2548. **Gavrilov, Th.**, and **S. Simonovitch.** [Gorges of the Jora and Alasan.] *Mat. Geol. Kark.*, ser. 2, kn. ix, pp. 1-176. Map, 1: 210,000, and sections. [1895.]
2549. **Gawalowski, A.** Ueber Petroleum - Beleuchtung. *Pharm. Centralhalle*, bd. xvii, p. 357. [1877.]
2550. ———. Mineralöle. *Allgem. österr. Chem.-Techn.-Zeit.*, bd. xxi, p. 642. [1887.]
2551. ———. Zur Ermittlung, bei welcher Temperatur Petroleum bereits Gase und Dämpfe entwickelt, die durch Hinzutreten von Luft Explosionsgefahr bringen können. *Oel-Fett-Indust.*, bd. ix, p. 466. [1893.]
2552. ———. [Purification of Petroleum Spirit.] *Allg. österr. Chem.-Techn.-Zeit.*, bd. xvii, p. 9. [1899.]
2553. ———. Die feuerfesten Heizraum- und Kesselanlagen mit besonderer Berücksichtigung der Rohöl-, Petrol-, Naturgas- und Generatorheizmaterialien. *Ibid.*, bd. xxix, p. 161. [1911.]
2554. **Gawronski, L. v.** Kritische Bemerkungen zum neuen zalizischen Naphtagesetze. *Petroleum Zeitschr.*, bd. ii, pp. 597-599. [1907.]
2555. ———. Die heutigen Ansichten über die Geologie der Karpaten und über die Naphtha-Lagerstätten. *Compt. Rend. Congr. internat. Pétrole*, sess. 3, t. ii, pp. 141-161. [1910.]
2556. **Gay-Lussac, J.** Analyse de la Paraffine. *Ann. Chim. Phys.*, sér. 2, t. i, pp. 78-80. [1832.]
2557. **Gebhardt, V.** Ueber stossendes Tiefbohren auf grosse Teufen. *Org. Ver. Bohrtechn.*, bd. xviii, pp. 97-109. [1911.]
2558. ———. Die Bewegung des Schwemmsandes bei der Schachtbohrung. *Ibid.*, pp. 109-111, 124-126, 135-137. [1911.]
2559. ———. Ueber Tiefbohrsysteme. *Ibid.*, pp. 163, 164. [1911.]
2560. **Gehrke, F.** Die neuere Entwicklung des Petroleumhandels in Deutschland. *Zeitschr. gesamt. Staatwissenschaft*, Erg., xx. [1906.]
2561. **Gaikie, A.** The Geology of Central and Western Fife and Kinross. Being a description of Sheet 40 and parts of Sheets 32 and 34 of the Geological Map. *Mem. Geol. Surv. Scotland*, 40. 8vo, Glasgow, 1900.
2562. ———. The Geology of Eastern Fife; being a Description of Sheet 41 and Parts of Sheets 40, 48 and 49 of the Geological Map. *Ibid.* 8vo, Glasgow, 1902.
- Gaikie, A.**, see **Howell, H. H.**
2563. **Gäinitz, H. B.** Ueber Albertit. *Sitz. nat. Ges. Isis*, 1871, p. 87.
2564. **Gäisler, J. F.** Paraffin as an Adulterant of Oleo-narine. *Journ. Amer. Chem. Soc.*, vol. xxi, pp. 605-608. [1899.]
2565. **Geissler, E.** Prüfung fetter Oele auf Mineralöle. *Corr.-blatt. Ver. anal. Chem.*, 1879, p. 55.
2566. **Gemmellaro, G. G.** [Volcanic Phenomena between Bologna and Florence.] *N. Jahrb.*, 1835, pp. 453, 454.
2567. **Gemmill**, —. Puerto Mexico. *Dipl. Cons. Rep.*, ann. ser., no. 4021, pp. 20-23. [1903.]
- Genserosow, A.**, see **Zelinsky, N. D.**
2568. **Genasne**, — da. Histoire Naturelle de la Province de Languedoc. 3 T. 8vo, Montpellier, 1776.
2569. **Genth, F. A.** First and Second Preliminary Reports on the Mineralogy of Pennsylvania. *Second Geol. Surv. Penns.*, B and BB. 8vo, Harrisburg, 1875, 1876.
2570. **Gentsch, W.** Die Petroleumlampe und ihre Bestandteile. Die Entwicklung der Petroleumlampe in den letzten Jahren. 8vo, Berlin, 1896.
2571. **George, H. C.** Petroleum. *Min. Ind.*, vol. xv, pp. 600-620. [1907.]
2572. ———. The Appalachian Oil Field. *Eng. Min. Journ.*, vol. lxxxix, pp. 131, 132. [1910.]
2573. ———. The Lima Oilfield. *Ibid.*, p. 134; vol. xci, p. 93. [1910, 1911.]
2574. ———. The Appalachian Oil Fields in 1910, 1911. *Ibid.*, vol. xci, pp. 90, 91; vol. xciii, p. 97. [1911, 1912.]
2575. **George, H. T.** Pennsylvania Oilfields. *Min. Ind.*, vol. xiv, pp. 485-487. [1906.]
2576. **Georges, E.** Effets physiologiques de l'éther de pétrole. *Compt. Rend.*, t. lviii, p. 1192. [1854.]
2577. **Georgi, J. G.** Von einer feuerfangenden Erde aus der Revalschen Stathalterschaft. *Prodol. Trudi Voln. Ekon. Obsch. St. Petersb.*, tch. xv, pp. 350-353. [1792.]
2578. **Georgius, F.** Neue Zerstäuberbrenner für Rohöl und andere flüssige Brennstoffe. *Braunkohle*, bd. ix, pp. 613-620. [1910.]
2579. ———. Neuerungen an Verbrennungsmaschinen unter besonderer Berücksichtigung der Oelmotoren. *Petroleum Zeitschr.*, bd. vi, pp. 956-962. [1911.]
2580. ———. Neuerungen an dem Gebiete der Bohrtechnik. *Ibid.*, bd. vi, pp. 2235-2237. [1911.]
2581. **Gehardt, C.** Sur le point d'ébullition des hydrogènes carbonés. *Ann. Chim. Phys.*, sér. 3, t. xiv, pp. 107-114. [1845.]
2582. **Gengros, —.** [Reconnaisances in Simbirsk, Kazan and Orenburg for Asphalt.] *Corn. Journ.*, 1837, t. 4, pp. 406-425.
2583. **Gersen, J.** Aardbaarslag in de Afdeling Lamatang-oeloe, residentie Palembang. *Nat. Tijdschr. Ned. Ind.*, dl. xxiv. [1862.]
2584. **Gervais, F. Yu.** [Boghead of a new Locality, Irkutsk.] *Gorn. Journ.*, 1902, t. 2, pp. 267-270.
2585. **Gesell, A.** [Iron-Ore Beds of the Marmaros.] *Föld. Köz.*, köt. iv, pp. 291-301. [1874.]
2586. ———. [Geological Description of the Occurrence of Coal, Petroleum and Ozokerite in the Ungvár District (North Hungary).] *Ibid.*, köt. v, pp. 21-35. [1875.]
2587. ———. Beitrag zur Kenntniss der Marmaroscher Petroleum-Fundstätten. *Jahrb. Ung. Karp.-Ver.*, bd. vii, pp. 518-523. [1880.]
2588. ———. Geologie der Marmaros, mit besonderer Berücksichtigung nutzbarer Mineralien. *Ibid.*, bd. viii, p. 326. [1881.]
2589. ———. Das Petroleumgebiet von Luh und das Goldbergwerk von Verespatak. *Jahresb. k. ung. geol. Anst.*, 1897, pp. 166-171. [1899.]
2590. ———. Die geologischen Verhältnisse des Petroleumvorkommens in der Gegend von Luh im Ungvár-Thal. *Mon. Jahrb. kon. ung. geol. Anst.*, bd. xii, pp. 323-335, pl. v. [1900.]
2591. ———. Die ungarische Petroleumterrains. *Allg. österr. Chem.-Techn.-Zeit.*, bd. vii, 1889.
- Gesell, A.**, see **Böckh, J.**
2592. **Gesner, A.** A Practical Treatise on Coal, Petroleum, and other distilled Oils. 8vo, New York and Philadelphia, 1861.
2593. **Genth, A.** Ueber die Natur und Destillationsproducte des Torbanehill-Mineral. 8vo, Göttingen, 1855.

- Geyer, W. E., see Morton, H.
2594. Giattini, G. B. Osservazioni geologiche sopra i Terreni Terziari di San Valentino (Chièti), e sopra i loro Giacimenti di Bitume. *Giorn. Geol. prat.*, t. v, pp. 169-197: pl. iv. [1907]
2595. Gibbons, W. S. Kerosene Oil. London, 1862.
2596. Gibertini, D., and A. Piccinini. Analisi dei gaz combustibili naturali di Torre e Salsomaggiore. *Gazz. Chim. Ital.*, vol. xxiii, pt. 2, pp. 559-576. [1893.]
- Gibson, A. M., see McCalley, H.
2597. Gibson, G. R. Historical Sketch of the Petroleum Industry of North America. 188-.
2598. Gibson, T. W. Reports of the Bureau of Mines, Ontario. nos. 10-18. [1901-1909.]
2599. Gilbertini, A. Sull' olio minerale d'America che serve all' illuminazione privata. *Ann. Chim. Ital.*, t. xxxviii, pp. 141-145. [1864.]
2600. ———— Analisi dell' acqua salsa di Salso Maggiore. *Rend. R. Ist. Lomb.*, t. iv, p. 591. [1871.]
2601. Gildemeister, E., and F. Hoffmann. Die aetherischen Oele. Berlin, 1899.
2602. Gilev, K. [Search for Oil in the Caucasus.] *Gorn. Journ.*, 1866, t. 1, pp. 282-285.
2603. ———— [Recent Information of Oil Discovery in the Kuban.] *Ibid.*, t. 2, pp. 507-511.
2604. Gill, A. H. A Short Hand-Book of Oil Analyses. 8vo, Philadelphia, 1898.
2605. ———— A Test for the Gunning Quality of Lubricating Oils. *Journ. Amer. Chem. Soc.*, vol. xxiv, pp. 467, 468. [1902.]
2606. ———— Report of Committee D2 on Standard Tests for Lubricants. *Proc. Amer. Soc. Test. Mat.*, vol. x, pp. 117-146. [1910.]
2607. Gill, A. H., and L. R. Forrest. The Hydrocarbons of the Wool-Grease Oleines. *Journ. Amer. Chem. Soc.*, vol. xxxii, pp. 1071-1073. [1910.]
2608. Gill, A. H., and H. R. Healey. Some Thermal Properties of Naphthas and Kerosenes. *Petrol. Rev.*, vol. vii, pp. 92, 93, 408, 409. [1902.]
2609. Gill, A. H., and S. P. Hunt. The Determination of Methane and Hydrogen by Explosion. *Journ. Amer. Chem. Soc.*, vol. xvii, pp. 986-994. [1895.]
2610. Gill, A. H., and S. N. Mason. The Detection of Mineral Oil in Distilled Grease Oleines. *Journ. Amer. Chem. Soc.*, vol. xxvi, pp. 665-671. [1904.]
2611. Gill, C. H., and E. Mensel. On Paraffin and its Products of Oxidation. *Journ. Chem. Soc.*, vol. xxi, pp. 466-471. [1869.]
2612. Giljelen, F. M. L. The Oil Regions of Pennsylvania: with Maps and Charts of Oil Creek, Alleghany River, etc. 8vo, Pittsburgh, 1864.
2613. Gillet de Laumont, F. P. N. Observations sur les schistes bitumineux, sur les bitumes ou matières bitumineuses, et sur les Grès Psammites cités dans le mémoire de M. Leschevin. *Journ. Mines*, t. xxxiii, pp. 46-52. [1813.]
2614. Gillieron, —. Sur les couches de pierre à chaux et l'asphalte de Goumoëns. *Act. Soc. Hévét. Sci. Nat.*, 1829, p. 51.
2615. Gilpin, E. The Geology of Cape Breton. The Minerals of the Carboniferous. *Trans. Nov. Scot. Inst.*, vol. vii, pp. 214-226. [1889.]
2616. Gilpin, J. E., and O. E. Bransky. The Diffusion of Crude Petroleum through Fuller's Earth. *Amer. Chem. Journ.*, vol. xlii, pp. 251-303. [1910.]
2617. Gilpin, J. E., and M. P. Cram. The Fractionation of Crude Petroleum by Capillary Diffusion. *Bull. U. S. Geol. Surv.*, no. 365. Pp. 33. 1908.
- Gilpin, J. E., see Day, D. T.
2618. Gintl, H. Galizisches Petroleum und Ozokerit. *Allgemeine Illustrirte Weltausstellung*, bd. i, pp. 236-259. [1872.]
2619. ———— Das Petroleum- und Ozokerit-Territorium Galiziens. *Mitth. k.-k. Geol. Ges. Wien*, bd. xviii, pp. 230-232. [1875.]
2620. ———— Die Petroleum-Gebiete Baku's und Persiens. *Oesterr. Monatschr. Orient*, 1876, pp. 103, 157.
2621. Gintl, H. Ueber das Vorkommen und die Handelsverhältnisse des Petroleums in Rumänien. *Oesterr. Zeitschr. Berg- u. Hüt.*, bd. xxvi, pp. 460, 461, 475, 476. [1878.]
2622. Gintl, H. E. Die Concurrenzfähigkeit des galizischen Petroleums, mit Rücksicht auf die neuen Oelgruben in Sloboda-Rungurska nächst Kolomea. *Techn. Vortr. Abhandl.*, h. vi, pp. 3-27. [1885.]
2623. Gintl, W. Gutachten: über die Anlage einer Petroleumraffinerie. *Oesterr. Sanitätsb.*, nos. 8, 9, 10. [1889.]
2624. Girard, J. La Vaseline artificielle et les Huiles de Vaseline. *Journ. Pét.*, t. iii, pp. 619, 620. [1903.]
2625. ———— La Formation du Pétrole dans la nature. *Ibid.*, t. iv, pp. 126, 127, 149, 150, 173, 174, 197, 198. [1904.]
2626. ———— Contribution à l'étude de la Vaseline. *Ibid.*, p. 151. [1904.]
2627. ———— La Chimie du Pétrole. *Ibid.*, pp. 217, 219, 220. [1904.]
2628. ———— Les bougies de paraffine et les bougies de pétrole. *Ibid.*, 224. [1904.]
2629. ———— Pétrole et Alcool. *Ibid.*, t. v, pp. 409-411: t. vi, pp. 41, 42. [1905, 1906.]
2630. ———— Nouvelle méthode de raffinage, basée sur l'emploi simultanée de l'acide azotique et des poudres métalliques. *Ibid.*, t. vi, p. 3. [1906.]
2631. ———— L'Odeur des Pétroles. *Ibid.*, pp. 69, 71, 138, 139, 199-202, 261, 262, 293, 295. [1906.]
2632. ———— Chauffage à l'Alcool et Chauffage au Pétrole. *Ibid.*, pp. 167-169. [1906.]
2633. ———— Quelques emplois de la Vaseline et de la Paraffine. *Ibid.*, pp. 385, 386. [1906.]
2634. ———— La Synthèse des Pétroles. *Ibid.*, t. vii, pp. 1, 3. [1907.]
2635. ———— La désodorisation des huiles de goudron. *Corps. Gras. Industr.*, t. xxxiii, pp. 183, 184. [1907.]
2636. ———— Nouvelles méthodes de désodorisation des pétroles huiles de schistes, et huiles de goudron. *Gr. Cit.*, t. i, pp. 114, 115, 129, 139, 144-146. [1907.]
2637. ———— La Transformation des Pétroles en matières grasses et en savons. *Gr. Cit.*, t. ii, pp. 26, 27. [1907.]
2638. Girard, J. B. Traité pratique des Machines Marines motrices, des machines auxiliaires, des machines à Pétrole et à Gaz. 2<sup>e</sup> T. 8vo, Paris, 1901.
2639. Girard, R. de. L'ambre et le pétrole dans le canton de Fribourg. *Bull. Soc. Fribourgeoise. Sci. Nat.*, t. xii, pp. 45, 46. [1906.]
- Giron, —, see Benoit, E.
2640. Glasnapp, M. Ausstellung, Beleuchtung und Naphtaindustrie. *Riga. Ind.-Zeu.*, 1888, nos. 1-6.
2641. Glasgow, A. G. Carburetted Water Gas. *Proc. Cleveland Inst. Eng.*, 1896-1897, pp. 43-76, pl. [1897.]
- Glasgow, A. G., see Humphreys, A. C.
2642. Glass, J. G. H. Report on the Concessions of the Peking Syndicate, Limited, in the Provinces of Shansi and Honan, China. 8vo, London, 1899.
2643. Glasser, E. Les Richesses Minérales de la Nouvelle-Calédonie. *Ann. Mines*, sér. 10, t. iv, *Mém.*, pp. 299-392, 397-536, pls. xi-xiii: t. v, pp. 29-154, 503-620, 623-701, pls. i, ii, xii. [1903, 1904.]
2644. Glinzer, E. Neuerungen auf dem Gebiete der Beleuchtung. *Zeitschr. angew. Chem.*, bd. xvi, pp. 386, 387. [1903.]
2645. ———— Technische Heizwertbestimmung fester, flüssiger, und luftförmiger Brennstoffe. *Ibid.*, bd. xix, p. 655. [1906.]
2646. ———— Die Heizwertbestimmung flüssiger Brennstoffe mit dem Junkersschen Kalorimeter. *Ibid.*, pp. 1422-1426. [1906.]
2647. Glockner, E. F. v. Der Ozokerit, ein neues Mineral. *Journ. Chem. Phys.*, bd. lxix, pp. 215-221. [1833.]
2648. ———— Grundriss der Mineralogie. 1839.
2649. ———— Mineralogische Beobachtungen aus Mähren. *Jahrb. k.-k. geol. Reichs.*, bd. vi, pp. 95-103. [1855.]

2650. **Glogon, J. A. de.** Die Tiefbohrung. *Org. Ver. Bohrtchn.*, bd. xviii, pp. 242-249. [1911.]
2651. **Gloth, H. W.** Ueber das Cholesterin und einige Phytosterin. *Munich*, 1910.
2652. **Glover, S.** Notes on the Enrichment of Coal Gas, more particularly bearing upon Enrichment by the Peebles Oil-Gas Process. *Journ. Gaslighting*, vol. lxiii, pp. 1050-1054, 1058-1061, 1176, 1177. [1894.]
2653. **Gluschkov, L. N.** Surakhanl. *Neph. Dielo*, 1906, pp. 111-117, 447-451, 628-635.
2654. **Gmelin, S. G.** Reise durch Russland zur Untersuchung der drey Natur-Reiche. 4 Bde. 4to, *St. Petersburg*, 1784.
2655. **Gniewosz, S., and A. Walisz.** Ueber die Absorption von Gasen durch Petroleum. *Zeitschr. physik. Chem.*, bd. i, pp. 70-72. [1887.]
2656. **Good, S. T.** [Particular Account of the Mud Volcano at Grobogan, Java, in] Miscellaneous Observations on the Volcanic Eruptions at the Islands of Java and Sumbawa. *Quart. Journ. Sci. Lit. Arts*, vol. i, pp. 245-258. [1816.]
2657. **Goodrey, J. C. H.** Notes on the Geology of Japan. *Quart. Journ. Geol. Soc.*, vol. xxxiv, pp. 542-555; map. [1878.]
2658. **Gooding, F.** On the Petroleum or "Green-tar" and the "Manjack" of Barbados. *Proc. Sci. Assoc. Trinidad*, vol. i, pp. 37-47. [1867.]
2659. **Godstone, F. H.** Air-Gas from Gasoline. *Engl. Mech.*, vol. xxvi, p. 358. [1877.]
2660. **Göbel, F., C. Claus, and A. Bergmann.** Reise in die Steppen des südlichen Russlands. 2 Bde. 4to, *Dorpat*, 1838.
2661. **Göbel, H.** Ueber Anwendung und Nutzen von Radbahnen aus Eisen und Asphalt. 8vo, *Kiel*, 1895.
2662. **Göbel, J.** Diagraphie Thermalium Aquarum in Misnia apud Hermannudros [Meissen]. 8vo, *Leipsic*, 1576.
2663. **Goethem, van.** Ueber die Fortschritte im Abteufverfahren bei der Petroleumgewinnung. *Zeitschr. Ver. deutsch. Ing.*, bd. xiv, pp. 707, 708. [1900.]
2664. **Göttische, G.** Die Kältermaschinen. *Hamburg* (Ed. iii), 1907.
2665. **Götzl, A.** Schwefelbestimmung in flüssigem Brennstoff und in Petroleum. *Zeitschr. angew. Chem.*, bd. xviii, pp. 1528-1531. [1905.]
2666. **Goldingham, A. H.** The Design and Construction of Oil Engines. 8vo, *New York*, 1901.
2667. ——— Oil Engines: a Review. 8vo, *London*, 1904.
2668. **Goldlust, H.** Die Naphtaindustrie in Baku im Jahre 1905. *Montan-Zeit. Oesterr.-Ung. Balkan*, bd. xiii, pp. 344-346. [1906.]
2669. **Goldschmidt, G.** Ueber das Idryl. *Sitz. k. Ak. Wiss. Wien*, bd. lxxvi, abth. 2, pp. 319-332. [1878]; bd. lxxxi, abth. 2, pp. 415-429. [1880.]
2670. ——— Ueber Idrialin (vorläufige Mittheilungen). *Ibid.*, bd. lxxviii, abth. 2, pp. 536-540. [1878.]
2671. ——— Untersuchung über das Idrialin. *Ibid.*, bd. lxxx, abth. 2, pp. 287-306. [1880.]
2672. **Goldsmith, E.** Asphaltum and Amber from Vincenttown, N.J. *Proc. Ac. Nat. Sci. Philadel.*, 1879, pp. 40-42.
2673. **Goldstein, A. H., see Mabery, C. F.**
2673. **Goldstein, M.** Ueber Siedepunkte normaler Aethane. *Ber. deutsch. chem. Ges.*, bd. xii, pp. 689-693. [1879.]
2674. **Goldstone, L. P.** Fresno County. 10th *Ann. Rep. State Min. Calif.*, 1890, pp. 183-204. [1890.]
2675. **Golitzia, N.** [Sketch of the Petchora Region in 1887.] 8vo, *Archangel*, 1887.
2676. **Golubyatnikov, D. V.** [Daghestan Mediterranean Deposits.] *Bull. Com. geol. Russ.*, t. xxi, pp. 185-250, pl. iv. [1902.]
2677. ——— [Geological Exploration of the Oilfields of Kaitago-Tabasaran, and the Derbent District.] *Ibid.*, pp. 697-754, pls. vii-ix. [1902.]
2678. ——— [Geological Researches in 1903 in the Apscheron Peninsula.] *Ibid.*, t. xxiii, pp. 289-330, pls. xiii-xi. [1904.]
2679. **Golubyatnikov, D. V.** [The Bereket Oilfield.] *Bull. Com. geol. Russ.*, t. xxv, pp. 361-412, pls. iii-v. [1906.]
2680. ——— [Geological Structure of the Bibi-Eibat Properties of the Moscow-Volga Oil Co.] *Ibid.*, t. xxvi, Journ., pp. 216-220. [1907.]
2681. ——— [Apscheron Oilfields.] *Ibid.*, t. xxvii, Journ., pp. 91-93. [1908.]
2682. ——— [Surakhani Gas and Oil Region.] *Ibid.*, pp. 181-222. [1908.]
2683. ——— Die Insel Sviatoi (Gouvernement Baku). *Mém. Com. geol. Russ.*, sér. 2, no. 28. Pp. 39; 3 pls. and map. [1908.]
2684. ——— [Ramani Oilfield, Baku.] *Bull. Com. geol. Russ.*, t. xxviii, Journ., pp. 30-33. [1909.]
2685. ——— [Beds with Petroleum and with Water at Bibi-Eibat.] *Ibid.*, pp. 164-170. [1909.]
2686. ——— [Structure of Plot 4, Bibi-Eibat.] *Ibid.*, pp. 243, 244. [1909.]
2687. ——— [Geological Structure of the Apscheron Peninsula.] *Ibid.*, t. xxix, Journ., pp. 11-20, map. [1910.]
2688. ——— [Prospects of Plot 27, Bibi-Eibat.] *Ibid.*, pp. 131-133. [1910.]
2689. ——— [Yield of Plot 51, Bibi-Eibat.] *Ibid.*, pp. 133, 134. [1910.]
2690. ——— [Structure and Production of Plot 25, Bibi-Eibat.] *Ibid.*, pp. 205-207. [1910.]
2691. **Golubyatnikov, D. V., and A. N. Ryabinin.** [Geological Structure of the Digin Estate and Vicinity (Binagadi, Baku).] *Ibid.*, t. xxv, Journ., pp. 19, 20, 41-43. [1906.]
- Golubyatnikov, D. V., see Bogdanovitch, K. I.; and Volarovitch, P. E.**
2692. [Gomes, J. P.] O Betume do Libollo (Provincia d'Angola). *Rev. Obras Publ. Minas*, t. xxix, pp. 162-169. [1898.]
2693. ——— Mineræ descubertas em Portugal. *Comm. Dir. Trab. Geol. Portugal*, t. iii, pp. 199-209. [1898.]
2694. ——— Composição do "Libollite." *Ibid.*, pp. 290, 291. [1898.]
2695. ——— Novos apontamentos sobre a "Libollite" (provincia d'Angola). *Ibid.*, t. iv, pp. 206, 207. [1901.]
2696. **Gonnard, F.** Sur les filons de quartz de Charbonnières les Varennes (Puy de Dôme). *Compt. Rend.*, t. cviii, pp. 667-669. [1888.]
2697. **Goodchild, J. G.** Some of the Modes of Origin of Oil Shales, with Remarks upon the Geological History of some other Hydrocarbon Compounds. *Trans. Edinb. Geol. Soc.*, vol. vii, pp. 121-131. [1897.]
2698. ——— The Origin of the Bituminoid Cement of the Cathness Flagstones. *Proc. R. Phys. Soc. Edinb.*, vol. xiii, pp. 316-327. [1897.]
2699. **Goodenough, W. J.** Memoranda regarding Fuel Oil aboard Ship. *Marine Engineering*, vol. viii, pp. 4-6. [1903.]
2700. **Goodwin, W. L., see Robinson, G. C.**
2700. **Goodyear, W. A.** Petroleum, Asphaltum, and Natural Gas [of California]. 7th *Ann. Rep. State Min. Calif.*, 1887, pp. 63-114. [1888.]
2701. ——— Colusa County. 10th *Ann. Rep. State Min. Calif.*, 1890, pp. 153-164. [1890.]
2702. ——— Lake County. *Ibid.*, pp. 227-271. [1890.]
2703. ——— Mendocino County. *Ibid.*, pp. 314-322. [1890.]
2704. **Goppelsröder, —.** Ueber Petroleum und dessen Producte, nebst einem Abhang über Feuerlöschmittel. *Basle*, 1869.
2705. **Gorby, S. S.** Geology of Benton County, Indiana. *Ann. Rep. Geol. Surv. Indiana*, vol. xv, pp. 198-220. [1886.]
2706. ——— The Wabash Arch. *Ibid.*, pp. 228-241. [1886.]
2707. ——— Geology of Miami County, Indiana. *Ibid.*, vol. xvi, pp. 165-188. [1889.]
2708. ——— Natural Gas and Petroleum. *Ibid.*, pp. 189-301. [1889.]
2709. ——— Limits of Natural Gas Supply. *Eng. Mag.*, vol. v, pp. 419-426. [1893.]



2710. **Gorby, S. S.** Introduction to Eighteenth Annual Report. *Ann. Rep. Geol. Surv. Indiana*, vol. xviii, pp. 9-16. [1894.]
- Gorceix, H., see Fouqué, F.**
2711. **Gordon, A.** Trinidad Petroleum. *Journ. Soc. Arts*, vol. xvi, pp. 763, 764. [1868.]
2712. **Gordon, C. H.** The Port Huron Oil-field [Michigan]. *Ann. Rep. Michigan Geol. Surv.*, 1901, pp. 269-281, [1902.]
2713. **Gordon, J. W.** Report of the Asphalt Industry Commission, Colony of Trinidad, and Minutes of Evidence. 2 vols. Fo, London, [1902.]
2714. **Gordon, L. C.** [Oil at Khatan.] *Admin. Rep. Railways of India*, 1887-1888.
2715. **Gordon, T. E.** Persia Revisited. 8vo, London and New York, 1895.
2716. **Gordon, W. M.** Trinidad and Tobago. Reports on the Blue Loom for 1908, 1909, 1910. *Colonial Rep.*, ann. ser., nos. 621, 664. [1909, 1911.]
2717. **Gorainow, W., and A. Butlerow.** Sur la condensation des hydrocarbures de la série éthylique, et la transformation de l'éthylène en alcool éthylique. *Bull. Ac. Imp. Sci. St. Pétersb.*, sér. 2, t. xviii, pp. 501-505. [1873.]
2718. **Goriani, M.** Pholidophorus Facii, n.f. nel Raib'liano di Cazzaso in Carnia. *Riv. Ital. Paleont. Perugia*, t. xiii, pp. 117-122, pl. II. [1907.]
2719. **Gosling, E. B. A.** Treatise on Ozokerite. *Sch-Mines Quarterly*, vol. xvi, pp. 41-68. [1895.]
2720. **Gosnell, R. C.** The Year-Book of British Columbia and Manual of Provincial Information, to which is added a Chapter containing much special information respecting the Canadian, Yukon, and Northern Territory generally. 8vo, Victoria (B. C.), 1897.
2721. **Gossiaux, —, and — Fouque.** Minéraux des Basses Alpes. Société en vue de l'exploitation des Asphaltes et schistes des Concessions des Plaines. 8vo, Marseilles, 1885.
2722. **Gottlieb, J.** Untersuchung des Gänsefettes und der Oelsäure. *Ann. Chem. Pharm.*, bd. lvii, pp. 33-67. [1846.]
2723. **Gottlieb, J. M.** Vorkommen und Gewinnung des Erdöls in Rumänien. *Berg-Hütt.-Zeit.*, bd. lxii, pp. 517-519. [1903.]
2724. **Gotscho, L.** Ueber die Vorteile der gleichzeitigen Anmeldung von Patenten und Gebrauchsmustern, speziell bei Neuerungen in den Asphalt- und Teer-Industrie. *Asphalt-Teerind.-Zeit.*, bd. v, pp. 289, 290. [1905.]
2725. **Gould, C.** Report upon the Resinous Shales . . . near . . . the River Mersey. Fo, Tasmania, 1861.
2726. **Gould, C. N.** The Oil Fields of Oklahoma. *Eng. Min. Journ.*, vol. lxxvii, p. 259. [1907.]
2727. ——— The Mineral Resources of Oklahoma. *Manuf. Record*, 1907.
2728. ——— The Future of Natural Gas in Oklahoma. *Proc. Nat. Gas Assoc. Amer.*, no. 5. [1910.]
2729. ——— Brief Chapters on Oklahoma's Minerals. *Oklahoma Geol. Surv. Bull.*, no. 6. [1910.]
2730. **Gould, C. N., L. L. Hutchison, and G. Nelson.** Preliminary Report on the Mineral Resources of Oklahoma. *Oklahoma Geol. Surv. Bull.*, no. 1. Pp. 84. [1908.]
2731. **Gould, E. B.** Report for the years 1891-1896 on the Trade of Port Said. *Dipl. Cons. Rep.*, ann. ser., nos. 1095, 1259, 1447, 1610, 1774, 1988. [1892-1897.]
2732. **Gounot, M. A.** Note sur les Mines de Bitume exploitées en Albanie. *Ann. Mines*, sér. 10, Mém., t. iv, pp. 5-23. [1903.]
2733. **Govi, S.** Appunti su alcune Salse e Fontane Ardentí della Provincia di Modena. *Riv. Geogr. Ital.*, t. vii, pp. 425-431. [1906.]
2734. **Grabein, P.** Die Tiefbohrtechnik im Dienste der Wissenschaft. *Deutsche Bergwerks-Zeitung*, 1911.
2735. **Grabill, L. R.** On the Peculiar Features of the Bassick Mine [Colo.]. *Trans. Amer. Inst. Min. Eng.*, vol. xi, pp. 110-120. [1883.]
2736. **Grabowski, J.** Ueber den galizischen Ozokerit und das Ceresin. *Zeitschr. allg. österr. Apoth.-Ver.*, bd. lxxxvi, 1877.
2737. **Gracey, W. T.** Sakhalin. Discovery of New Source of Naphtha Supply in Okhotsk Sea. *U. S. Cons. Rep.*, no. 330, pp. 98, 99. [1908.]
2738. **Gräfe, E.** Die Bestimmung des Schmelz- und Erstarrungspunktes beim Paraffin. *Braunkohle*, bd. i, p. 361. [1902.]
2739. ——— Ueber das Vorkommen und die Bestimmung von Methanohomologen im Oelgas. *Journ. Garbe-leucht.*, bd. xlvi, pp. 524-528. [1903.]
2740. ——— Ueber Mischungen von Paraffin mit hochschmelzenden Stoffen. *Chem.-Zeit.*, bd. xxviii, pp. 1144-1149. [1904.]
2741. ——— Zur Schwefelbestimmung in Oelen, bituminösen Körpern, Kohlen und ähnlichen Substanzen. *Zeit. chr. angew. Chem.*, bd. xvii, pp. 616-619. [1904.]
2742. ——— Anwendung der Jodzähl auf Mineralöle. *Ibid.*, bd. xviii, pp. 1589-1584. [1905.]
2743. ——— Zur Kenntniss der Einwirkung von Licht und Luft auf Braunkohlenteeröle. *Braunkohle*, bd. v, p. 571. [1906.]
2744. ——— Die Braunkohlenteer-Industrie. *Monogr. chem.-techn. Fabrik.*, bd. II. Pp. 116. [1906.]
2745. ——— Zur Unterschöderung des Braunkohlenteerpeches von andern Pechen. *Chem.-Zeit.*, bd. xxx, pp. 298, 299. [1906.]
2746. ——— Beeinträchtigt Schwefel die Leuchtkraft von Oelen. *Petroleum Zeitschrift*, bd. i, pp. 606-608, 859, 860. [1906.]
2747. ——— Welche Methode der Jodzählbestimmung ist bei Mineralölen anzuwenden. *Ibid.*, pp. 631-633. [1906.]
2748. ——— Die Anwendung der Jodzähl in der Mineralölchemie (8 Vers. deutsch. Chem.). *Ibid.*, pp. 636-640. [1906.]
2749. ——— Ueber italienische Petroleum. *Ibid.*, pp. 745, 746. [1906.]
2750. ——— Zur Wasserbestimmung in Rohpetroleum. *Ibid.*, pp. 813-817. [1906.]
2751. ——— Ueber classisches Petroleum. *Ibid.*, bd. II, pp. 278-280. [1907.]
2752. ——— Die Petroleumchemie im Jahre 1906. *Ibid.*, pp. 318-323. [1907.]
2753. ——— Ueber die spezifische Wärme von Mineralölen. *Ibid.*, pp. 521-525. [1907.]
2754. ——— Ueber Entfärber, mit besonderer Berücksichtigung der deutschen Fullererde. *Ibid.*, bd. III, pp. 292-295. [1907.]
2755. ——— Ueber die Valenta'sche Reaktion. *Chem. Rev. Fet-Harz-Ind.*, bd. xiv, pp. 112-115. [1907.]
2756. ——— Ueber Mischung von Paraffin mit hochschmelzenden Stoffen. *Chem.-Zeit.*, bd. xxxi, pp. 19, 20, 100, 101. [1907.]
2757. ——— Asphalt- und Erdöl in Spanien. *Asphalt-Teerind.-Zeit.*, bd. vii, p. 48. [1907.]
2758. ——— Chemische Fabrik Griesheim-Elektron. Ueber die physiologischen Wirkungen des Tetrachlorkohlenstoffes und des Petrolbenzins. *Zeitschr. angew. Chem.*, bd. xx, p. 241. [1907.]
2759. ——— Zur Kresosotbestimmung in Braunkohlenteerprodukten. *Braunkohle*, bd. vi, h. 17. [1907.]
2760. ——— Laboratoriumsbuch für die Braunkohlenteer-Industrie. *Labor-büch. chem. Ind.*, bd. vi. Pp. 192. [1908.]
2761. ——— Das Erdöl aus dem Kalisalzbergwerk Desdemona bei Alfed an der Leine. *Kali*, bd. II, pp. 468-470. [1908.]
2762. ——— Ueber die Vakuumdestillation bei Mineralölen. *Petroleum Zeitschr.*, bd. III, pp. 1128-1131. [1908.]
2763. ——— Ueber die Dampfdestillation. *Ibid.*, bd. IV, pp. 268-270. [1908.]
2764. ——— Schlusswort zu den Ausführungen des Herrn Gurwitsch. *Ibid.*, pp. 621-623. [1909.]
2765. ——— Die Petroleumchemie im Jahre 1908. *Ibid.*, pp. 1033-1037. [1909.]
2766. ——— Ueber die Verdampfungswärme von Mineralölen. *Ibid.*, bd. v, pp. 569-571. [1910.]

2767. **Gräfe, E.** Die Erdölchemie im Jahre 1909. *Petroleum Zeitschr.*, bd. v., pp. 1074-1079. [1910.]
2768. ——— Die schöttische Schiefersteerindustrie. *Ibid.*, bd. vi, p. 69. [1910.]
2769. ——— Ein Erdöl aus dem Salzbergwerke "Glnck-Auf" bei Sondershausen. *Kali*, bd. iv, pp. 261-263. [1910.]
2770. ——— Ueber Canadischen Oelschiefer. *Braunkohle*, bd. ix, pp. 424-426. [1910.]
2771. ——— Ueber die Volumenverminderung des Paraffins beim Erstarren und Auskristallisieren. *Chem. Rev. Fett-Harz-Ind.*, bd. xvii, pp. 3-5. [1910.]
- 2772 to 2787 (blank).
2788. ——— Zwei Erdölle aus Kalksalzbergwerken [Alfeld und Sondershausen]. *Centr. Min.*, 1911, pp. 1-4.
2789. ——— Die Asphaltseen Südamerikas. *Petroleum Zeitschr.*, bd. vi, pp. 2024-2029. [1911.]
2790. ——— Die Verwendung von Erdöl im Strassenbeton. *Asphalt-Teerind.-Zeit.*, bd. xii, p. 140. [1912.]
- 2791 (blank).
2792. **Gräger, J. N.** Chemische Untersuchung einzelner Braunkohlen. *Arch. Pharm.*, bd. xxviii, pp. 34-41. [1846.]
2793. **Graffenauer, J. P.** Essai d'une Minéralogie économique-technique des Départements du Haut-et-Bas-Rhin. 8vo, *Strasbourg*, 1806.
2794. **Graham, —**. Report for the year 1906 on the Trade of Kansas. *Dipl. Cons. Rep.*, ann. ser., no. 3774. [1907.]
2795. **Gramberg, —**. [Petroleum in Palembang.] *Nat. Tijdschr. Ned. Ind.*, dl. xxviii, pp. 467-470. [1865.]
2796. **Grand, A.** Mémoire sur les Huiles de Pétrole. *Mém. Soc. Ing. Civ.*, 1869, pp. 533-649; 1870, pp. 85-90.
2797. **Granger, A.** L'Asphalte et le Bitume. Leurs Applications. *Mon. Sci.*, t. lxxi, pp. 713-730. [1909.]
2798. **Grauer, —**. Appareil pour constater le degré d'inflammabilité des huiles de pétrole destinées à l'éclairage. *Compt. Rend. Soc. Encour. Ind. Nat.*, no. 15. [1872.] See also Rapport fait par V. de Luynes . . . sur un appareil . . . *Bull. Soc. Encour. Ind. Nat.*, t. lxxii, pp. 400, 401. [1872.]
2799. **Grauer, J. F.** De l'Affectation Porique, et de ses divers traitements, suivis d'un essai de traitement par l'Huile de Pétrole purifiée. 4to, *Paris*, 1872.
2800. **Graville, A. B.** Burning Gas in the Apennines. *Ann. Phil.*, vol. v, pp. 233-235. [1815.]
2801. **Gras, S.** Sur le bitume pétrole de calcaire de la Porte de France, à Grenoble. *Bull. Soc. Stat. Isère*, t. i, pp. 15-18. [1838.]
2802. ——— Statistique minéralogique des Basses Alpes. 8vo, *Grenoble*, 1840.
2803. **Gratacap, L. P.** Newfoundland, its Geology and Mineral Resources. *Min. World*, vol. xxiii, pp. 525, 526. [1905.]
2804. **Graul, —**. Asphalt in Muschelkalk. *Humboldt*, bd. vii, p. 311. [1888.]
2805. ——— Geologische Beschreibung der Umgegend von Rappoltsweiler. *Rappoltsweiler*, 1889.
- Gravell, J.**, see **Nichol, B. G.**
2806. **Gray, A.** Gas and Oil Prospecting in Eastern Canada. *Mining Journ.*, vol. xcii, pp. 130, 131. [1911.]
2807. **Gray, J.** Apparatus for determining the Flash Points of heavy Mineral Oils. *Journ. Soc. Chem. Industr.*, vol. x, p. 348. [1891.]
2808. **Gray, T.** The Phenols from Shale Oil. *Journ. Soc. Chem. Ind.*, vol. xxi, pp. 845-847. [1902.]
- Gray, T. T.**, see **Sherman, H. C.**
2809. **Graven, L.** Petroleum Fuel in Locomotives on the Tehuantepec National Railroad of Mexico. *Proc. Inst. Mech. Eng.*, 1906, pp. 265-312.
2810. **Grébl, A.** Emploi des Hydrocarbures Extraits des Pétales. *Génie Civ.*, t. liv, pp. 136-138. [1908.]
2811. **Green, A. H., C. L. N. Foster, and J. R. Dakyns.** The Geology of the Carboniferous Limestone, Yoredale Rocks, and Millstone Grit of North Derbyshire. *Mem. Geol. Surv.*, 1869.
2812. **Green, Burton.** Kimmeridge Shale: its Origin History and Uses. 8vo, *London*, 1836.
2813. **Greene, F. V.** Asphalt and its Uses. *Trans. Amer. Inst. Min. Eng.*, vol. xvii, pp. 353-373. [1889.]
2814. **Greenwell, G. C. and E. W. Binney.** [Kerosene Shale, New South Wales.] *Trans. Manch. Geol. Soc.*, vol. xi, pp. 63-70. [1872.]
- Greer, F. W.**, see **Day, D. T.**
2815. **Gregorius, R.** Erdwachs (Zeresin), Paraffin und Montanwachse, deren Darstellung und Verwendung. 8vo, *Vienna*, 1907.
2816. **Gregory, H. E.** The San Juan Oil Field, San Juan County, Utah. *Bull. U.S. Geol. Surv.*, no. 431, pp. 11-25, pl. ii. [1910.]
2817. **Gregory, K.** [Oil at Bobrka and Besco.] *Verh. k.-k. geol. Reichs.*, 1861, pp. 196-199.
2818. **Gregory, O. M.** Handling Crude Oil. Heating Oil. The Use of Crude Oil for Firing Benches and for Enriching Coal Gas (Experiences, Pacific Coast Gas Assoc.). *Amer. Gas Light Journ.*, vol. lxxv, pp. 363-365. [1901.]
2819. **Gregory, W.** On the Composition of Petroleum of Rangoon. *Trans. R. Soc. Edinb.*, vol. xiii, pp. 124-140. [1835.]
2820. ——— Ueber eine fette Substanz, von einem thierischen Körper herrührend. *Ann. Chem. Pharm.*, bd. lxi, pp. 362-364. [1847.]
2821. ——— Ueber einen schwarzen humusartigen Körper der auf der Oberfläche des Schottischen Sees, "Loch Dochart," am 22 November 1846, nach einem schwachen Erdbeben erschien. *Ibid.*, pp. 365, 366. [1847.]
2822. ——— Composition of the Boghead Coal. *Journ. Micr. Sci.*, vol. ii, pp. 200, 201. [1854.]
2823. **Gréhant, N.** Analyse exacte du gaz des marais. Dissociation de plusieurs Carburés d'hydrogène obtenue dans l'eudiomètre-grisomètre. *Compt. Rend.*, t. cxlvii, pp. 1199, 1200. [1908.]
2824. **Greim, G.** Ein Besuch der Schlammsprudel von Sassaolo. *Globus*, bd. lxxvii, pp. 37-42. [1900.]
2825. **Grempe, P. M.** Der Wert des russischen Petroleums als Leuchtmaterial. *Zeitschr. Beleuchtungsweesen*, bd. vi, pp. 108-110. [1900.]
2826. **Greve, W. H. de.** Petroleum of Aardolie en haar voorkomen in Nederlandsch-Indie. *Tijdschr. Nijverh. Landb. Ned.-Ind.*, dl. xl, pp. 281-356. [1865.]
2827. **Griesbach, C. L.** On the Geology of the Section between the Bolan Pass in Biluchistan and Girishk in Southern Afghanistan. *Mem. Geol. Surv. Ind.*, vol. xviii, pp. 1-60. [1881.]
2828. ——— The Geology of the Saféd Koh. *Rec. Geol. Surv. Ind.*, vol. xxv, pp. 59-109, 2 pls. [1892.]
2829. ——— General Report of the Work carried on by the Geological Survey of India for the period from the 1st April 1900 to the 31st March 1901; 1901 . . . 1902. 8vo, *Calcutta*, 1901, 1902.
2830. **Griffin, C.** Account of an Oil-Lamp Furnace, for Melting Metals at a White Heat. *Chem. News*, vol. ix, p. 3. [1864.]
2831. **Griffin, G. W.** A Tour through New Zealand. *Rep. Cons. U.S.*, vol. viii, pp. 380-384. [1884.]
2832. **Griffin, R. S.** Emploi des huiles minérales comme combustibles. *Mém. Soc. Ing. Civ.*, 1886, vol. 2, pp. 231-235.
2833. **Griffith, W.** Journals of Travels in Assam, Burma, Bootan, Afghanistan, and the neighbouring Countries. 8vo, *Calcutta*, 1847.
2834. **Griffiths, A. E.** On the occurrence of Phenol in *Pinus sylvestris*; a Discovery bearing on the Flora of the Carboniferous Epoch and the Formation of Petroleum. *Chem. News*, vol. xlix, p. 95. [1884.]
2835. ——— Paraffin-Shale from Servia. *Chem. News*, vol. xlix, pp. 107, 108. [1884.]
2836. ——— On certain Eocene Formations of Western Servia. *Quart. Journ. Geol. Soc.*, vol. xlii, pp. 565, 566. [1886.]
2837. **Griffiths, A. E., and N. J. Bluman.** Les bases azotées dans le pétrole roumain. *Bull. Soc. Chim. Paris*, sér. 3, t. xxv, pp. 725, 726. [1901.]

2838. **Grimes, G. E.** Geology of Parts of the Myingyan, Magwe, and Pakokku Districts, Burma. *Mem. Geol. Surv. Ind.*, vol. xviii, pp. 30-71, pls. ii, iii. [1900.]
2839. **Grimsley, G. P.** Kansas Mines and Minerals. *Trans. Kansas Acad. Sci.*, vol. xvii, pp. 200-207. [1901.]
2840. ——— Economic Geology of Iola and vicinity. *Trans. Kansas Acad. Sci.*, vol. xviii, pp. 78-82, pl. [1903.]
2841. ——— Report on the Geology of the Panhandle Counties of West Virginia: Ohio, Brooke, and Hancock Counties. *Rep. West Virginia Geol. Surv.* Pp. 378, 16 pls., 8 maps. [1907.]
2842. ——— Pleasants, Wood, and Ritchie Counties (West Virginia). *Ibid.* Pp. 352, 21 pls, 3 maps. [1910.]
2843. **Grine, H. A.** Making Producer Gas from Crude Oil. *Min. Sci. Press.*, vol. ciii, pp. 381, 382. [1911.]
2844. **Grinnell, W. F.** Petroleum Wells in Germany. *Rep. Cons. U.S.*, vol. i, pp. 120-122. [1880.]
2845. **Gripper, H. A.** Rapid Method for Determining the Composition of Lubricating Oils. *Chem. News*, vol. lxx, p. 27. [1892.]
2846. **Griswold, W. T.** The Berea Grit Oil Sand. *Bull. U.S. Geol. Surv.*, no. 198. Pp. 44, map. [1902.]
2847. ——— Structural Work during 1901 and 1902 in the Eastern Ohio Oil-fields. *Ibid.*, no. 213, pp. 335-344. [1903.]
2848. ——— Natural Gas. *Min. Res. U.S.*, 1905. [1906.]
2849. ——— The Production of Petroleum in 1905, 1906. *Ibid.*, 1905, 1906. [1906, 1907.]
2850. ——— Structure of the Berea Grit Oil Sand in the Flushing Quadrangle, Harrison, Belmont, and Guernsey Counties, Ohio. *Bull. U.S. Geol. Surv.*, no. 346. Pp. 30, 2 maps. [1908.]
2851. **Griswold, W. T., and M. J. Munn.** Geology of Oil and Gas Fields in Steubenville, Burgetstown, and Claysville Quadrangles, Ohio, West Virginia, and Pennsylvania. *Ibid.*, no. 318. Pp. 196, 13 pls. [1907.]
2852. **Grittner, A.** Ueber die Bestimmung von Mineralölen in den fetten Oelen. *Zeitschr. angew. Chem.*, bd. iii, p. 261. [1890.]
2853. ——— Nachweis von Harzöl in fetten und Mineralölen. *Ibid.*, bd. iv, pp. 265, 266. [1891.]
2854. **Grodnitzky, B.** Ueber das elsässer Petroleum. *Karlsruhe*, 1884.
2855. **Grölling, A. v.** The Application of Continuous Distillation to Petroleum. *Petr. Rev.*, vol. ii, pp. 150, 151. [1900.]
2856. **Groot, C. de.** Kolon en aardhars uit de omliggende van Batavia. *Nat. Tijdschr. Ned.-Ind.*, dl. xvi. 1859.
2857. **Groschuff, E.** Ueber die Löslichkeit von Wasser in Benzol, Petroleum und Paraffinöl. *Zeitschr. Elektrochem.*, bd. xvii, pp. 348-354. [1911.]
2858. **Groschus, J. A.** Ueber die Anwendung des Gesetzes (der Densitätszahlen) auf einen Fall in der Thermochemie. *Ber. deutsch. chem. Ges.*, bd. xix, pp. 497-500. [1886.]
2859. **Grossman, H.** Die Entwicklung der Berg- und Hüttenindustrie in Japan. *Berg- Hütt. Rundsch.*, bd. vii, pp. 243-248. [1911.]
2860. **Grossmann, J.** Die Schmiermittel. Methoden zu ihrer Untersuchung und Wertbestimmung. 8vo, *Wiesbaden*, 1894.
2861. **Grotowsky, L.** Ueber den Einfluss des Lichtes auf Mineralöle. *Journ. Gasbeleucht.*, bd. xi, pp. 498-500. [1868.]
2862. ——— Der derzeitige Stand des Paraffin- und Mineralöl-Gewinnung in der Provinz Sachsen. *Zeitschr. Berg- Hütt.-Salinenw.*, bd. xxiv, pp. 351-401, pls. vi-viii. [1876.]
2863. ——— Empyreumatisch Untersuchung des Pyropissits. *Zeitschr. Paraff. Industr.*, 1871, no. 21.
2864. ——— Darstellung und Verwendung des Paraffinölgases. *Zeitschr. Berg- Hütt.-Salinenw.*, bd. xxv, pp. 176-182. [1877.]
2865. **Grotowsky, L.** Die Verwerthung der Nebenprodukte und Abfallchemikalien in der Mineralölfabrication. *Zeitschr. Paraff. Ind.*, 1878, p. 38.
2866. ——— Die chemische Zusammensetzung des käuflichen Paraffins. *Ibid.*, p. 50.
2867. **Grottrian, H.** Asphalt von Sicilien. *Jahresb. Ver. Nat. Braunsch.*, 1880-81, pp. 27, 28. [1881.]
2868. **Grover, F. A.** Practical Treatise on Modern Gas and Oil Engines. 8vo, *Manchester*, 1897.
2869. **Groves, C. E., and W. Thorp.** Chemical Technology. *London*, 1889, 1895.
2870. **Groye, F. J. B. M. de la, see Ménard de la Groye, F. J. B.**
2870. **Grünberg, S.** Das Naphtagesetz. *Zeitschr. Volkswirt. Sozialpolit.*, bd. xvi. [1907.]
2871. **Grüner, H.** Mittheilungen über einige Ergebnisse meiner Aufnahmen im Westpreussischen Arbeitsgebiete. I. Das Asphaltsteinlager zu Dlugimost, Kreis Strasburg in Westpreussen. *Jahrb. k. preuss. geol. Landesanst.*, bd. xix, pp. ccxxvii, ccxxviii. [1900.]
2871. **Grüning, H., see Engler, C.**
2872. **Grundy, J.** Mineral Production in India [1892-1901]. *Trans. Manch. Geol. Soc.*, vol. xxviii, pp. 11-15. [1903.]
2873. **Gruszkiewicz, J.** Bestimmung des Wassergehaltes in Rohölreservoren. *Naphtha*, bd. xiv, pp. 23-25. [1906.]
2874. ——— Neuer Apparat zur Gewichtsbestimmung von Rohöl und Petroleumdestillaten in Reservoiren. *Ibid.*, pp. 314-316. [1906.]
2875. ——— Neuer Verfahren der Gewichtsbestimmung von Rohöl-Verunreinigungen in Reservoiren. *Ibid.*, p. 353. [1906.]
2876. ——— Ueber Petroleumrubengase. *Ibid.*, bd. xv, pp. 51-54, 92-94. [1907.]
2877. ——— Ueber die Verbrennungstemperatur des Rohöls. *Ibid.*, bd. xvi, pp. 68, 69. [1908.]
2878. ——— Das Heizöl. *Ibid.*, pp. 93-95. [1908.]
2879. ——— Rohöl als Rohprodukt für die Fabrikation von Russ. *Ibid.*, pp. 108-110. [1908.]
2880. ——— Das Rohöl in seiner Verwendung für Dieselmotoren. *Ibid.*, pp. 131, 132. [1908.]
2881. ——— Blitzableiter auf den Rohölgruben. *Ibid.*, pp. 151-154. [1908.]
2882. ——— "Ansprüche" von Rohöl aus Rohrleitungen. *Ibid.*, pp. 170-172. [1908.]
2883. **Gruszkiewicz, J., and W. Bartozewicz.** Ein Beitrag zur Bestimmung des Ausdehnungskoeffizienten von leicht erstarrbaren Oelen. *Petroleum Zeitschr.*, bd. ii, p. 525, 526. [1907.]
2884. **Gruszkiewicz, J., and M. Wielezynski.** Einiges über Rohölreservoirs. *Naphtha*, bd. xv, pp. 337-340. [1907.]
2884. **Gruszkiewicz, J., see Wielezynski, M.**
2885. **Grzybowski, J.** [Microfauna of the Carpathian Sandstone in the Dukla District.] *Rozpr. Ak. Umiej. Krakow*, ser. 2, t. ix, pp. 180-214. [1895.]
2886. ——— [Microscopic Examination of the Mud of Borings and Oil-Wells. I. Potok and Krosno District. II. General Considerations.] *Kosmos*, 1897.
2887. ——— Die Mikrofauna der Karpathen-bildungen II. Foraminiferen der naphthaführenden Schichten der Umgebung von Krosno. *Bull. Internat. Acad. Sci. Cracovie*, 1897, p. 180-186.
2888. ——— La Microfaune des Grès des Carpathes. III. Le Foraminifères des Couches à Inoceramus des environs de Gorlice. *Bull. Internat. Acad. Sci. Cracovie*, 1901, pp. 221-226, pls. viii, ix.
2889. ——— Die Tertiärlagerungen des nördlichen Peru und ihre Molluskenfauna. *N. Jahrb.*, beil.-bd. xii, pp. 610-664, pls. xv-xx. [1899.]
2890. ——— Geologische Skizze der Umgebung von Schodnica bei Drohobycz in der Ostkarpathen Galizien. *Monat. Zeit. Oest. Ung. Balkanl.*, bd. xi, pp. 227, 228. [1904.]
2891. ——— Roryslaw. Une monographie géologique. *Bull. Internat. Ac. Sci. Cracovie*, 1907, pp. 87-127, pls. iii, iv.

2892. **Grzybowski, J.** Beiträge zur Geologie Boryslaws. *Naphtha*, bd. xvi, pp. 30-33, 48, 49. [1908.]
2893. — Zur Ursprungstheorie des Erdöls. *Compt. Rend. Congr. internat. Pétrole*, sess. 3, t. ii, pp. 156-188. [1910.]
2894. **Guareschi, I.** [Fossil Resin from the Upper Val d'Arno.] *Nuovo Cimento*, ser. 2, vol. v, pp. 175-185. [1871.]
2895. **Gubkin, I. M.** [Short Report on Operations in the Kuban Oilfields.] *Bull. Com. géol. Russ.*, t. xxix, Journ., pp. 317-342. [1910.]
- Gubkin, I. M.**, see **Tcharnovski, S. I.**
2896. **Gümbel, C. W. v.** Ueber das Vorkommen von Torfpechkohle Dopplerit im Dachelmoos bei Berchtesgaden. *N. Jahrb.*, 1858, pp. 278-287.
2897. — Geognostische Beschreibung des Königreichs Bayern. 4 Bde. 8vo, *Gotha*, 1861, 1868, 1879, 1891.
2898. — Ueber ein neues Erdharz (Euosmit) aus der Braunkohlen-Lager bei Thunsenreuth in der Bayerischen Oberpfalz. *N. Jahrb.*, 1864, pp. 10-14.
2899. — Ueber das Eruptionsmaterial des Schlammlavankans von Paternò am Aetna und der Schlammvulkane im Allgemeinen. *Sitz. k. Ak. Wiss.*, bd. ix, pp. 217-273. [1879.]
2900. — Geognostische Mittheilungen aus den Alpen. VI. Ein geognostischer Streifzug durch die Bergamasker Alpen. *Ibid.*, bd. x, pp. 164-240. [1880.]
2901. — Beitrag zur Kenntniss der Texturverhältnisse der mineralischen Kohlen. *Ibid.*, bd. xiii, pp. 111-216, 3 pls. [1883.]
2902. — Geologie von Bayern. 2 Bde. 8vo, *Cassel*, 1884-1894.
2903. — Nachträge zu den geognostischen Beschreibung des bayerischen Alpengebirges. *Geogn. Jahresh. München*, bd. i, pp. 163-185. [1888.]
2904. — Die mineralisch-geologische Beschaffenheit der auf der Forschungsreise S.M.S. Gazelle gesammelten Meeresgrundablagerungen. 4to, *Berlin*, 1889.
- Gümbel, C. W. v.**, see **Schwager, A.**
2905. **Günsberg, R.** Ueber die Verbrennung der flüchtigen Kohlenwasserstoffe des Petroleums im Säurestoffgase. *Polyt. Journ.*, t. ccxxviii, pp. 454-457. [1878.]
2906. **Guérin, H.** La vapeur de pétrole. Sa production et son emplol. *Gén. Civ.*, t. xxxiv, pp. 88-90. [1898.]
- Guermontprez**, —, see **Derville**, —.
2907. **Guerra, M. F.** Solución a las cuestiones tecnico-geológicas, propuestas por el Sr. Lic. D. Luis Méndez, presidente de la Academia de jurisprudencia y legislación, sobre si son denunciabiles los mantos de carbón de piedra y los depósitos de petróleo que existan en terrenos de propiedad particular. *Bol. Soc. Geol. Mex.*, t. ii, pp. 87-110. [1906.]
2908. **Guettard**, —. Mémoire sur la Minéralogie de l'Auvergne. *Hist. Acad. Roy. Sci. Paris*, 1769, Mém., pp. 538-576.
2909. — Mémoire sur les Mines de Sel de Wieliczka en Pologne. *Ibid.*, 1762, pp. 493-516, pl. 28.
2910. **Guéymard, E.** Note sur l'im perfectionnement de gaz hydrogène carboné à l'usage de l'éclairage. *Bull. Soc. Statist. Isère*, sér. 2, t. vi, pp. 365, 366. [1861.]
2911. **Guibert-Lassalle, R.** La Chimie pétrolière. Les Composés du Pétrole. *Informations Pétrolières*, 1911.
2912. **Guidotti, G.** Lettera . . . al Signor Girolamo Gottardi. 8vo, *Parma*, 1813.
2913. — Traité complet des Bains de Lesignano (Parme).
2914. **Guignet, C. E.** Analyse immédiate des tourbes; leur constitution chimique. *Compt. Rend.*, t. xci, pp. 888, 889. [1880.]
2915. **Guignet, E.** Sur divers échantillons d'argile et de bouille du Brésil. *Ibid.*, t. lxxxiv, pp. 1326-1328. [1877.]
2916. **Guilbert**, —, **Collin, A.** **Guiselin**, and **A. Pihan**. Appareils et méthode permettant de caractériser la valeur éclairante des Pétroles lampants destinés à l'éclairage. *Compt. Rend. Congr. internat. Pétrole*, sess. 3, t. ii, pp. 810-812. [1910.]
- Guilbert**, —, see **Calvet**, —.
2917. **Guillard, A.** Dei varj metodi d'illuminare e principalmente del nuovo metodo idro-bituminoso. *Poitecnico*, vol. i, pp. 9-16. [1839.]
2918. — Delle varie materie dalle quale estrarre il gas illuminante. *Ibid.*, pp. 225-236. [1839.]
2919. **Guillemin, E.** [Combustible Shale from the Migri district in the Caucasus.] *Bull. Soc. Imp. Nat. Mosc.*, 1858, pp. 325-328.
2920. **Guillet**, —. Goudronage. 8vo, *Paris*, 1909.
2921. **Guiselin, A.** [The Influence of Methods of Distillation on the yield and quality of Distillates.] *Monit. Int. Pét. Roum.*, t. ix. [1908.]
2922. — Sur l'Industrie du Schiste en France. *Journ. Pét.*, t. viii, pp. 85-89. [1908.]
2923. — Pétrole et Alcool. *Ibid.*, pp. 121-125, 138-140, 151-157, 167-173, 180-183, 228, 229. [1908.]
2924. — Congrès Maritime International pour les applications du moteur à mélange tonnant et du moteur à combustion interne aux marines de guerre, de commerce, de pêche et de plaisance. *Ibid.*, t. ix, pp. 4, 5. [1909.]
2925. — Réforme du Tarif Douanier Français, appliqué aux Importations des Pétroles Bruts en France. *Ibid.*, pp. 34-38. [1909.]
2926. — Méthode graphique pour l'étude d'une classification rapide des différent pétroles bruts et de leurs dérivés. 8vo, *Paris*, 1909.
2927. — Die Nutzbarmachung der Kälte in der Petroleumindustrie. *Petroleum Zeitschr.*, bd. vi, pp. 133-135. [1910.]
2928. — Mode de représentation graphique, permettant la lecture rapide de la composition d'un pétrole et donnant des indications sur son origine. *Compt. Rend. Congr. internat. Pétrole*, sess. 3, t. ii, pp. 61-68. [1910.]
2929. — Examen des Résultats obtenus en employant le Procédé Ludwig pour l'Extraction par l'Acéto-ne des Huiles de Graissage. *Ibid.*, pp. 561-563. [1910.]
2930. — Sur les Produits Bruts importés en France et les Dérivés qui en sont extraits. *Ibid.*, pp. 564-578. [1910.]
2931. — [Loss of Petroleum and its Products by Storage in large Cylinders of Tinned Iron.] *Mét. Grasses*, t. xxxix, p. 2323. [1911.]
2932. — Procédés divers pour l'obtention, la séparation et le raffinage des différent paraffines contenues dans les huiles brutes de pétrole. *Journ. Pét.*, t. xi, p. 35. [1911.]
2933. **Guiselin, A.**, and **D. Holdé**. Rapport sur les Applications du Froid à l'Extraction de la paraffine des Acides Gras. *Compt. Rend. Congr. internat. Froid*, sess. 1, t. iii, pp. 251-263. [1908.]
2934. **Guiselin, A.** and **L. Madoué**. Étude d'un Pétrole brut de Tunisie. *Journ. Pét.*, t. viii, pp. 101-105. [1908.]
2935. — Examen d'un Sable imprégné de Pétrole provenant de la région de Burgos. *Ibid.*, t. ix, pp. 97-100. [1909.]
2936. — Le traitement douanier des pétroles bruts et raffinés en France. *Ibid.*, t. x, p. 34. [1910.]
- Guiselin, A.**, see **Arbel**, —; **Benoit, E.**; **Calvet**, — and **Guilbert**, —.
2937. **Gukhmann, A.** [Study of Waste Gases from Baku Steam Furnaces.] *Trudi Bak. Otd. Imp. Russk. Tekhn. Obsch.* [1904.]
2938. **Gulbenkian, C. S.** La Transcaucasie et la Péninsule d'Apchéron; Souvenirs de Voyage. 12mo, *Paris*, 1891.
2939. — La Péninsule d'Apchéron et le Pétrole Russe. (*Rev. deux Mondes*, 15th May.) 8vo, *Paris*, 1891.
2940. **Guldenstedt, J. A. v.** [Sketch of Grusia and the Caucasus from travels in 1770-1773.] 4to *St. Petersburg*, 1787.

2941. **Gulischambarov, S. I.** [On the Oil Trade and Illumination by Oil.] *Golos.*, 1874, no. 96.
2942. ——— [Petroleum Fountains.] *Gorn. Journ.*, 1879, t. 4, pp. 34-53.
2943. ——— [Sketch of the Development and Present State of the Naphtha Industry of Baku, with a detailed plan of all the Oil Wells.] *Tiftis*, 1879.
2944. ——— [Present State of the Production of Photogene in Baku, with a detailed plan of Black Town, where all the photogene refineries are concentrated.] *Baku*, 1879.
2945. ——— Die Naphthaheizung der Dampfer und Lokomotiven. 8vo, *St. Petersburg*, 1880.
2946. ——— [Distribution and Quantity of Petroleum in the Apsheron Peninsula.] *Jurn. Russk. Fiz. Khim. Obsch.*, t. xii, otd. i, pp. 196-204. [1880.]
2947. ——— [Petroleum as Fuel.] *Gorn. Journ.*, 1880, t. 2, pp. 251-277.
2948. ——— [Materials for the History of the Photogen Industry.] *Ibid.*, t. 4, pp. 327-344.
2949. ——— [Petroleum of Lower Elsass.] *Ibid.*, 1881, t. 3, pp. 267-282.
2950. ——— [A Visit to the Oilfields of the United States.] 8vo, *Tiftis*, 1882.
2951. ——— [L. E. Nobel's Oil-sprinkler for Rotary Furnaces.] *Tekhnik*, 1882, no. 2.
2952. ——— Map of the Apsheron Peninsula. *Tiftis*, 1882, 1886.
2953. ——— [The Ozokerite Industry in Galicia.] *Gorn. Journ.*, 1882, t. 4, pp. 180-198.
2954. ——— Essai d'une Bibliographie générale de l'Industrie des Pétroles. 8vo, *St. Petersburg*, 1883, 1884.
2955. ——— [The Composition of American Lubricating Oils and Fats.] *Zap. Imp. Russk. Tekhn. Obsch.*, g. xvii, otd. i, pp. 257-260. [1883.]
2956. ——— [The use of Petroleum for various Medicinal Purposes.] *Tiftis*, 1884.
2957. ——— [Various Laws relating to the Exploitation, Storage, Refining and Transport of Petroleum in Russia and other countries.] *Tiftis*, 1884.
2958. ——— [On the Oil Industry in the Caucasus, and its bearing on the question of the imposition of a petroleum duty.] *Zap. Imp. Russk. Tekhn. Obsch.* g. xx, *Trudi*, otd. i, pp. 227-236, 309-323. [1886.]
2959. ——— [The use of Petroleum for Domestic Purposes, Kitchens, Bakeries, etc.] *St. Petersburg*, 1887.
2960. ——— [The use of Petroleum for Metallurgical Purposes.] 1888.
2961. ——— [Short Review of the Rise of Kerosene Production in the Caucasus.] *Zap. Imp. Russk. Tekhn. Obsch.*, g. xxii, v. 2, pp. 57-69. [1888.]
2962. ——— [Short Review of the Naphtha Industry in the Caucasus.] *Ibid.*, pp. 70-77. [1888.]
2963. ——— [Consumption of Fuel for Business Purposes.] *Russ. Manuf. and Trade Department*, 1893.
2964. ——— [Description of Manufactures in the Baku District.] 1893.
2965. ——— [Petroleum-Heating of Steamships, Locomotives, Stationary Boilers, Metallurgy, House, Kitchen, Baking, and other Stoves.] 8vo, *St. Petersburg*, 1894.
2966. ——— [The Productiveness of Russia.] 1894.
2967. ——— [The Petroleum Industry of the United States of North America in connection with the general business development of the country.] 8vo, *St. Petersburg*, 1894.
2968. ——— [On Naphtha Fuel for Vehicles.] *Zap. Imp. Russk. Tekhn. Obsch.*, g. xxix, July, pp. 71-86. [1895.]
2969. ——— [On the Oil Industries of America and Russia, with special reference to Texas and the Liquid Fuel Trade.] *Petrol. Rev.*, vol. vii, pp. 81-88. [1902.]
2970. ——— Petroleum and its Products in the World's Industry and Trade. *Petrol. Rev.*, vol. xiii, pp. 43, 44, 63, 64. [1905.]
2971. ——— Transport Maritime en Vrac du Pétrole et de ses Produits en Russie. *Compt. Rend. Congr. internat. Pétrole*, sess. 3, t. II, pp. 889-910. [1910.]
2972. **Gullo, L.** Sull' Applicazione dell' Olio minerale all' Illuminazione del Fari Francesi. *Giorn. Gen. Cir.*, vol. xv, pp. 1, 61, 121. [1877.]
2973. **Gumilla, J.** El Orlnoco Ilustrado y defendido; Historia Natural, Civil, y Geographica de este gran rio y de sus caudalosa svertientes. Ed. II, 2 Tt. 4to, *Madrid*, 1745.
2974. **Guppy, R. J. L.** Note on Petroleum and Naphtha. *Proc. Sci. Assoc. Trinidad*, vol. I, pp. 138, 139. [1867.]
2975. ——— On the Discovery of Tertiary Coal at Williamsville, Savangrande. *Proc. Sci. Assoc. Trinidad*, vol. II, pp. 110-115, pl. [1877.]
2976. ——— Preliminary Geological Notes on the Marbela Manjak Mine. *Geol. Mag.*, dec. 5, vol. I, pp. 276, 277. [1904.]
2977. ——— Second Note on the Marbela Manjak Mine (Trinidad). 8vo, *Port-of-Spain*, 1909.
2978. **Guriev, —.** Puits de naphte et volcans boueux, situés aux environs de la ville de Kerch en Crimée. *Ann. Journ. Min. Russ.*, 1836, pp. 343, 344. [1840.]
- Gurit, —**, see **Lippmann, —.**
- Gurwitch, A.**, see **Stransky, —.**
2979. **Gurwitch, L.** Ueber die sogenannte "Dampfdestillation." *Petroleum Zeitschr.*, bd. iv, pp. 265-268. [1908.]
2980. ——— Ueber die Dampfdestillation. *Ibid.*, pp. 619-621. [1909.]
2981. ——— Chemie und Technologie des Erdöls im Jahre 1908-1910. *Zeitschr. angew. Chem.*, bd. xxii, pp. 1061-1070; bd. xxiii, pp. 1299-1306, 1353-1359; bd. xxiv, pp. 1249-1256. [1909-1911.]
2982. **Gusenburger, H.** Die Untersuchungen der Schmieröle und Fette mit specieller Berücksichtigung der Mineralöle. 8vo, *Luxemburg*, 1886.
2983. **Gusmani, L.** Il Combustibile Liquido. *Riv. Maritt.*, t. xxxvii, pp. 285-312, 578-595. [1904.]
2984. **Gustavson, G.** [Decomposition at Low Temperatures of American and Caucasian Petroleum.] *Jurn. Russk. Fiz. Khim. Obsch.*, t. xiii, otd. i, pp. 149-154. [1881.]
2985. ——— Formation of Brominated Aromatic Hydrocarbons by the action of Bromine and Aluminium Bromide on the Volatile Portions of Petroleum. *Ibid.*, t. xv, otd. i, pp. 401-404. [1883.]
2986. ——— Action of Aluminium Bromide on Ethylene and on the Bromides of Saturated Alcohols. *Ibid.*, t. xvi, otd. i, pp. 95-108. [1884.]
2987. **Guthrie, —.** Mineral Naphtha a Remedy for Cholera. *Pharm. Journ.*, vol. viii, p. 43. [1849.]
2988. **Guthrie, F.** On some Derivatives from the Olefines. *Journ. Chem. Soc.*, vol. xii, pp. 109-126; vol. xiii, pp. 35-47, 129-135; vol. xiv, pp. 128-142. [1860-1862.]
- Guthrie, J. K.**, see **Bunning, C. Z.**
2989. **Guttenbrunner, —.** [On the occurrence of Petroleum at Sömsze.] *Verh. Siebenb. Ver. Nat.*, bd. xvi, p. 214. [1865.]
2990. **Guyot, A.** Artesian Well at Terre Haute, Indiana. *Amer. Journ.*, ser. 2, vol. xlviii, pp. 270, 271. [1869.]
2991. **H—, G.** Metallputzmittel. *Seifens.-Zeit.*, bd. xxxvii, pp. 359, 360, 383, 384. [1910.]
2992. **H—, P.** Die Fabrication der Mineralschmieröle, speciell der aus russischen Residuen gewonnenen. *Chem.-Zeit.*, bd. x, pp. 603-605, 618. [1886.]
2993. **H—, R.** Der Zweitakt-Rohölmotor. *Seifenfabrik.*, bd. xxxi, pp. 649, 650. [1911.]
2994. **Haack, R.** Zur "Oxydation" und "Verselfung von Erdölen." *Chem.-Zeit.*, bd. xvi, pp. 1598, 1599. [1892.]
2995. **Haass, H. J.** Die geologische Bodenbeschaffenheit Schleswig-Holsteins mit besonderer Berücksichtigung der erratischen Bildungen in ihren Grundzügen für die gebildeten aller Stände gemeinverständlich dargestellt. 8vo, *Kiel and Leipzig*, 1889.
2996. **Haass, R.** Zur Prüfung des Petroleum auf seine Feuersgefährlichkeit. *Chem. Ind.*, bd. iii, pp. 123-126. [1880.]

- Haass, R.**, see Engler, C.
2997. **Haber, F.** Theorie der pyrogenen Reactionen aliphatischer Kohlenwasserstoffe. *Ber. deutsch. chem. Ges.*, bd. xxix, pp. 2691-2700. [1896.]
2998. ——— Experimental-Untersuchungen über Zersetzung und Verbrennung von Kohlenwasserstoffen. *Munich*, 1896.
2999. **Haber, F.**, and **H. Oechelhauser.** Ueber die Bestimmung von Aethylen neben Benzoldampf. *Ber. deutsch. chem. Ges.*, bd. xxix, pp. 2700-2705. [1896.]
3000. **H[abe]ts, A.** L'Exploitation du Pétrole dans les Carpathes. *Rev. Univ. Mines*, t. xxii, pp. 121-127. [1867.]
3001. **Habliz, G.** Bemerkungen in der persischen Landschaft Ghilan und auf den ghilanischen Gebirgen. *St. Petersburg*, 1783.
3002. **Haché, —.** Ein Beitrag zur Frage: Holz-, Stein- oder Asphalt-Pflaster. *Vorsk. Blätt.*, bd. xi, pp. 13-16. [1887.]
3003. **Hacht, E. v.** Zur Reinigung des Paraffins. *Chem.-Zeit.*, bd. v, p. 951. [1881.]
3004. **Hackel, R.** Ueber die Feststellung des Verhaltens von Schmiermaterialien in der Kälte. *Mitt. k.-k. techn. Gew.*, bd. xv, pp. 38-43. [1905.]
3005. ——— Ueber Viskositätsbestimmung der Schmieröle. *Ibid.*, pp. 44-51. [1905.]
3006. **Hackstaff, J. D.** Gas Engines and their varied uses in the Natural Gas Field. *Nat. Gas. Journ.*, vol. i, no. 7, pp. 14, 15. [1907.]
3007. **Haquet, B.** Neuesten physikalisch-politischen Reisen in den Jahren 1788 und 1789 durch die dachischen und sarmatischen oder nördlichen Karpathen. *Nürnberg*, 1790-1796.
3008. **Häberle, A. T.** The Oil-Fields of Honduras. Report to Amer. Bureau Manuf., 1911.
3009. **Hacker, H.** Kleinmotoren. 8vo, *Wiesbaden*, 1909.
3010. **Häpke, L.** Erdölwerke und Tiefbohrungen in der Lüneburger Heide. *Ber. Ges. deutsch. Naturf. Aerzte*, vers. 73. [1901.]
3011. ——— Die Erdölindustrie in der Lüneburger Heide. *Chem.-Zeit.*, bd. xxviii, pp. 618, 619; bd. xxix, pp. 466-468. [1904, 1905.]
3012. **Häussermann, C.** Zur Kenntniss der amerikanischen Benzine. *Polyt. Journ.*, bd. ccxxvii, pp. 477-479. [1878.]
3013. ——— Ueber die im Handel vorkommenden Asphaltarten und deren Verwendung zu technischen Zwecken. *Gewerbe-Bl. Würt.*, bd. xxiv, pp. 122-124, 130-132. [1878.]
3014. ——— Petroleum- und Steinkohlen-Benzine. *Ibid.*, bd. xxxii, pp. 49-52, 84-86. [1886.]
3015. **Hageman, J.** [Emanation of Carburetted Hydrogen at Larangan-Tokol, Madura.] *Nat. Tijdschr. Ned. Ind.*, dl. xxiv, pp. 467, 468, 488. [1862.]
3016. ——— Over de modderwelen van Kalanganjar en Poeloengan, delta van Soerabaja. *Ibid.*, dl. xxix, pp. 367-381. [1867.]
3017. **Hagenbach, E.** Versuch über Fluorescenz. *Ann. Phys. Chem.*, bd. cxlvi, pp. 65-89, 232-257, 375-405, 508-538. [1872.]
3018. **Hager, D.** Value of Geology. *Min. Eng. World*, 1910.
3019. ——— Value of Geology in the Petroleum Industry. *Ibid.*, Sept. 2, 1911.
3020. ——— Cave-Ins in Oil Wells. *Min. Sci. Press*, vol. ciii, pp. 166, 167. [1911.]
3021. ——— Geological Factors in Oil Production. *Ibid.*, pp. 738-741. [1911.]
3022. **Hager, H.** Paraffinpapier statt Wachspapier. *Pharm. Central-Halle*, bd. iv, no. 45. [1863.]
3023. ——— Prüfung des officinellen Petroleumums auf Verfälschung. *Ibid.*, bd. v, p. 55. [1864.]
3024. ——— Schwefelkohlenstoff ein gewöhnlicher Begleiter des Petroleumums und Benzols. *Ibid.*, bd. vii, p. 393. [1866.]
3025. ——— Unterscheidung des Petrobenzins und Steinkohlenbenzins. *Ibid.*, bd. xvi, p. 130. [1875.]
3026. **Hager, H.** Untersuchung des Wachses. *Pharm. Central-Halle*, bd. xxi, pp. 119-121, 129-131. [1850.]
3027. ——— Leichtes Verfahren, Ceresin, Ozokerit und Paraffin im Bienenwachs nachzuweisen. *Ibid.*, bd. xxx, pp. 565, 566. [1889.]
3028. ——— Zum Nachweise von Paraffin im Bienenwachs. *Zeitschr. anal. Chem.*, bd. xxix, pp. 480, 481. [1890.]
3029. **Hager, L.** The Mounds of the Southern Oil-fields. *Eng. Min. Journ.*, vol. lxxviii, pp. 137-139, 130-133, map. [1904.]
3030. **Haggard, J. G.** Report for 1892 on the Trade of Trieste. *Dipl. Cons. Rep.*, ann. ser., no. 1292. [1893.]
3031. **Haggard, W. H. D.** Report for the years 1891, 1892 on the Trade of Ecuador. *Ibid.*, no. 1146. [1893.]
3032. ——— Report for 1895 on the Trade of Tunis. *Ibid.*, no. 1791. [1896.]
3033. **Haidinger, W. v.** Ueber den Hartit, eine neue Species aus dem Ordnung der Erdharze. *Ann. Phys. Chem.*, bd. cxxx, pp. 261-265. [1841.]
3034. ——— Ueber den Isolyt, ein Mineral aus dem Geschlecht der Erdharze. *Ibid.*, bd. cxxxii, pp. 345-349. [1842.]
3035. ——— Ueber den Plauxit, ein Erdharz. *Ibid.*, bd. cxxxviii, pp. 275-277. [1844.]
3036. ——— Handbuch der bestimmenden Mineralogie, enthaltend die Terminologie, Systematik, Nomenclatur und Charakteristik der Naturgeschichte des Mineralreiches. 8vo, *Vienna*, 1845.
3037. ——— Notiz über den Hatchettin von Rossitz in Mähren. *Sitz. k. Ak. Wiss. Wien*, bd. ii, pp. 312-315. [1849.]
3038. ——— Ueber eine unter neuen Torflager bei Aussee gefundene gelatinöse Substanz (Doppierit). *Ibid.*, bd. iii, pp. 287-293. [1848.]
3039. **Hake, W. B.** Die Entwicklung und Bedeutung des "Rohölmotor System Diesel." *Petroleum Zeitschr.*, bd. vi, pp. 948, 946. [1911.]
3040. **Halaceanu, C.** [On the Productive Capacity of Oil Refineries.] *Revista Petrolului*, t. i, p. 390. [1908.]
3041. ——— [Rumanian Oilworks and the Contingency Law.] *Ibid.*, 1909.
- Halaceanu, C.**, see **Mrazec, L.**
3042. **Halder, W.** Modern Deep Drilling Practice in Europe. *Mining Mag. (N. Y.)*, vol. xiii, pp. 33-36. [1906.]
- Hale, C. F.**, see **Bradley, W. P.**
3043. **Hale, F. D.** Oil Prospects. Trinidad. *U.S. Cons. Rep.*, no. 354, p. 135. [1910.]
3044. **Hale, H.** Liquid-Fuel Supply (Western U.S.). *Cassier's Mag.*, vol. xl, pp. 3-16. [1911.]
- Hale, H.**, see **Hughes, H. H.**
3045. **Hale, J. P.** Salt. Chap. XII. (pp. 274-305) of "Resources and Industries of West Virginia," by M. F. Maury and W. M. Fontaine. 1876.
3046. **Hall, A. A.** Oil from the roof of the Cockshead Coal Seam, North Staffordshire. *Journ. Soc. Chem. Ind.*, vol. xxvi, pp. 1223, 1224. [1907.]
3047. **Hall, C. F.** Report of the State Supervisor of Oils [of Indiana] for 1895[-1898]. *Ann. Rep. Geol. Surv. Indiana*, vol. xx, pp. 467-474; vol. xxi, pp. 502-505; vol. xxii, pp. 397-402; vol. xxiii, pp. 1675-1706. [1896-1899.]
3048. **Hall, E. L.** Chemical Control of Oil Gas Manufacture. *Progress. Age*, vol. xxviii, pp. 966-969. [1910.]
3049. **Hall, J.** Geology of New York. Part IV. 4to, *Albany*, 1843.
3050. **Hall, T. M.** Note on the Occurrence of Mineral Oil in Shale at Barnstaple. *Trans. Devon. Assoc.*, vol. vi, part 2, p. 547. [1874.]
3051. **Halla, A.** Zur Pohl'schen Methode der Schmelzpunktsbestimmung. *Oesterr. Chem.-Zeit.*, bd. xlii, p. 29. [1910.]
3052. **Halleck, H. W.** Bitumen; its varieties, properties, and uses. *Papers Pract. Eng. U.S. Corps Eng.* 1842.

3053. **Haller, A., P. Sabatier, et J. B. Senderens.** Procédé d'épuration et de désodorisation des huiles de pétroles essences, éthers, beuzine, huiles de schistes, de résines et produits similaires. *Journ. Petr.*, t. ix, p. 9. [1909.]
- Halmaj, B.**, see **Engler, C.**
3054. **Halphen, G.** Sur la recherche des huiles végétales ou animales dans les huiles minérales. *Journ. Pharm. Chim.*, sér. 6, t. iii, pp. 16-19. [1896.]
3055. ——— Recherche de l'huile de résine dans les huiles minérales. *Ibid.*, t. xvi, pp. 478-483. [1902.]
3056. ——— [Determination of Benzene in Petroleum Spirit used in Motors.] *Les Matières Grasses*, t. iii, pp. 1987-1990. [1910.]
- Halphen, G.**, see **Riche, A.**
3057. **Halsted, E. P.** Report on the Island of Chedooba. 8vo, London, 1841.
3058. **Hamilton, A.** A New Account of the East Indies; giving a Description . . . of all the Countries and Islands which lie between the Cape of Good Hope and the Island of Japau. 2 vols. 8vo, Edinburgh, 1727.
3059. **Hamilton, E. H.** The Use of Oil for Smelting. *Eng. Min. Journ.*, vol. xci, pp. 224, 225. [1911.]
- Hammerschlag, H. A.**, see **Sherman, H. C.**
3060. **Hammon, W. H.** The Production of Natural Gas in the United States. *Min. Ind.*, vol. x, pp. 464-483. [1902.]
3061. ——— The Natural Gas Industry of the United States during 1902. *Ibid.*, vol. xi, pp. 481-483. [1903.]
3062. ——— Natural Gas Development. *Nat. Gas Journ.*, vol. i, no. 6, pp. 28, 29. [1907.]
3063. **Hamor, W. A.** The Technology of the Scottish Shale Oil Industry. Appendix (pp. 37-57) in **R. W. Ellis'** Report [no. 2025]. *Canada Dep. Mines*, no. 55. [1910.]
- Hamor, W. A.**, see **Baskerville, C.**
3064. **Hampson, C. S.** Report for 1891 on the Trade of Erzeroum. *Dipl. Cons. Rep.*, ann. ser., no. 1050. [1892.]
3065. **Hance, J. L.** Asphalt Deposits near Cardenas [Cuba]. *Rep. Cons. U.S.*, vol. xvii, pp. 126-128. [1895.]
3066. **Hanks, H. G.** Annual Report of the State Mineralogist [California] from June 1, 1880, to December 1, 1880.
3067. ——— Fourth Annual Report . . . May 15, 1884. 8vo, Sacramento, 1884.
3068. ——— The Mineral Hydrocarbons, their History, Geography, Geology, Physical and Chemical Properties and Uses. *Min. Sci. Press*, vol. lxxviii, pp. 341, 357, 374, 389, 406; vol. lxxix, pp. 5, 23, 40, 56, 102, 134, 151, 166, 359, 375, 391, 415 [1894]; vol. lxx, pp. 38, 39, 56, 71, 88, 109, 136, 150, 189, 263, 284, 393; vol. lxxi, p. 14 [1895].
3069. ——— Notes on Aragonite, a rare Californian Mineral. *Journ. R. Micr. Soc.*, 1905, pp. 673-676.
3070. **Hannay, P. S.** On the Assam Petroleum Beds. *Journ. As. Soc. Beng.*, vol. xiv, pp. 817-821. [1845.]
- Hannemann, —**, see **Ernecke, A.**
3071. **Hansberg, A.** The Naphtha-bearing Regions of Petchora. *Petroleum Rev.*, vol. xxi, pp. 213, 214. [1909.]
3072. **Hansells, N. V.** Om Baku. *Bihang Jernk. Ann.*, 1904.
- Hanson H. N.**, see **Richardson, F. W.**
3073. **Hanway, Jonas.** An Historical Account of the British Trade over the Caspian Sea, with a Journal of Travels from London through Russia into Persia, and back again through Russia, Germany, and Holland. 4 vols. 4to, London, 1753, 1754.
3074. **Harbordt, C.** Untersuchung des mineralischen Leuchtstoffes der Württembergischen Posidonien-Schiefer. *Tübingen*, 1862.
3075. **Harcus, W.** South Australia: Its History, Resources, and Productions. 8vo, London, 1876.
3076. **Harden, J. H.** Chart showing the Production of Anthracite Coal in the Lehigh, Schuylkill, and Wyoming Regions; Anthracite, Bituminous and Charcoal Pig Iron in the United States, and Petroleum in Pennsylvania, from 1820 to 1876. *Trans. Amer. Inst. Min. Eng.*, vol. v, pp. 504, 505, pl. x. [1877.]
3077. **Hargrove, J. O.** Annual Reports of the Inspector of Asphalts and Cements. *Rep. Eng. Dept. D.C.*, 1906-1911.
3078. **Harkema, V. M.** [Salt Lakes of the Uralski Province.] *Gorn. Journ.*, 1894, t. 1, pp. 425-460, pl. xvi.
3079. **Harker, J. A.**, and **W. F. Higgins.** On the Methods and Apparatus used in Petroleum Testing. *Coll. Res. Nat. Phys. Lab.*, vol. viii, pp. 19-39. [1911.]
3080. **Harkness, R.** On the Anthracite Schists; and the Fucoidal Remains occurring in the Lower Silurian Rocks of the South of Scotland. *Quart. Journ. Geol. Soc.*, vol. xi, pp. 468-476. [1855.]
3081. **Harman, D. W.** Journal of Voyages and Travels in the Interior of North America. *Andover, Mass.*, 1820.
3082. **Harper, L.** Geognostisches Bericht über ein sehr bedeutendes Petroleum-Lager in der königl. preussischen Provinz Hannover in Norddeutschland. *Brussels*, 1872.
3083. **Harperath, J.** Argentinisches Petroleum. *Compt. Rend. Congr. internat. Chim. appl.*, sess. 5, t. ii, pp. 527-530. [1904.]
3084. **Harperath, L.** Petroleo y Sal. *Bol. Acad. Nac. Ci. Cordoba*, t. xviii, pp. 153-272, 273-376. [1905, 1906.]
3085. **Harrington, —**. Report for the year 1906 on the Trade of Japan. *Dipl. Cons. Rep.*, ann. ser., no. 3896. [1907.]
3086. **Harris, C.** History of the Venango Oil Regions. *Titusville, Pa.*, 1866.
3087. **Harris, E.**, — **Perrine**, and **W. E. Hopper.** Oil and Gas in Northwestern Louisiana, with special reference to the Caddo Field. *Bull. Geol. Surv. U.S.*, no. 8, 1911.
3088. **Harris, E. L.** Petroleum Industry, Asiatic Turkey. Arrival of First Shipment of American Petroleum. *U.S. Cons. Rep.*, no. 357, pp. 196, 197. [1910.]
3089. **Harris, G. D.** Oil in Texas. *Science, n.s.*, vol. xlii, pp. 666, 667. [1901.]
3090. ——— Oil in Louisiana. *Rep. Geol. Surv. Louisiana*, part vi, pp. 265-275. [1902.]
3091. ——— Oil and Gas in Louisiana, with a brief Summary of their Occurrence in Adjacent States. *Bull. U.S. Geol. Surv.*, no. 429. Pp. 192; 22 pls. [1910.]
3092. **Harris, G. D.**, and **A. C. Veatch.** A Preliminary Report on the Geology of Louisiana. *Rep. Geol. Surv. Louisiana*, 1899, pp. 6-138, pls. l-xi, and map (1:190,080). [1900.]
3093. **Harris, H. G.** Heat Engines other than Steam. *Cantor Lectures*, vol. iii, 1889.
3094. ——— Petroleum as a Producer of Energy. *Prof. Papers Roy. Eng.*, vol. xvi, pp. 181-222. [1890.]
3095. **Harris, L. B.** Register of Mines and Minerals, with map, of Santa Barbara County, data collected March 1906. With maps of Summerland, Santa Maria, and Los Alamos Oil Fields. *Calif. State Min. Bureau*, 1906.
3096. **Harrison, A. H.** In Search of an Arctic Continent. *Geogr. Journ.*, vol. xxxi, pp. 277-287, map. [1908.]
3097. **Harrison, H. W. B.** Report for the year 1897 on the Trade of Spain. *Dipl. Cons. Rep.*, ann. ser., no. 2065. [1898.]
3098. **Harrison, J. B.** The Coral Rocks of Barbados. *Quart. Journ. Geol. Soc.*, vol. lxlii, pp. 318-337, pl. xxlii. [1907.]
3099. **Harrison, J. B.**, and **A. J. Jukes-Browne.** The Geology of Barbados. 8vo, London, 1890.
3100. **Harrison, W. J.** Consumption of Coal and Oil in California. 1902, 1903.
3101. **Hart, B.** On the Diseases and Accidents incidental to the Horse wherein the Rock Oil of Barbados or Green Mineral Pitch has proved a particularly useful remedy, with directions for use. 8vo, London, 1831.

3102. **Hartman, F. S.** Beschrijving van eenen togt naar de bovenlanden van Bandjermassin in het Jaar 1790. *Kron. Hist. Gen. Utrecht*, jr. xx, 1864.
3103. **Hartmann, C. F. A.** Vollständige Brennmaterialkunde. Ed. II. *Weimar*, 1847.
3104. ——— Ausfindung, Gewinnung, etc., der Mineralischen Brennstoffe. Ed. II. *Weimar*, 1853.
3105. **Hartmann, E.** Ueber die erschöpfende Chlorirung einiger hochmolecularer Fettkörper. *Ber. deutsch. chem. Ges.*, bd. xxiv, pp. 1011-1026. [1891.]
3106. **Hartmann, G.** Das Rohöl als Brennmaterial. *Petroleum Zeitschr.*, bd. v, pp. 380-383. [1910.]
3107. **Hartmann, W.** Leistungsversuche mit Petroleummotoren. *Zeitschr. Ver. deutsch. Ing.*, bd. xxxix, pp. 342-348, 373-380, 399-403, 469-474, 586-594, 616-622, 878-880. [1895.]
3108. **Hartmann, W.**, and **R. Schöttler.** Prüfung der Petroleummotoren. *Arb. deutsch. landw. Ges.*, h. vi, p. 86. [1894.]
3109. **Hartogh, —.** Beitrag zur Chemie der Mineraleöle. *Bonn*, 1909.
3110. **Hart, C. F.** Geology and Physical Geography of Brazil. 8vo, *Boston and London*, 1870.
3111. **Hasse, C.** Mittheilungen über Bergnaphtha. *Polyt. Journ.*, bd. cii, pp. 445-448. [1859.]
3112. **Hasselquist, F.** Iter Palæstinum, eller Resa til Heliga Landet, förrättad i fra år 1749 til 1752. 8vo, *Stockholm*, 1757.
3113. **Hassencamp, E.** Geognostische Beschreibung der Braunkohlenformation in der Rhön. *Verh. phys.-med. Ges. Würzb.*, bd. viii, pp. 185-211. [1858.]
3114. ——— Geologisch-paläontologische Untersuchungen über die Tertiarbildungen des Rhöngebirges. *Wurz. nat. Zeitschr.*, bd. i, pp. 193-213, pl. [1860.]
3115. **Hasenpflug, H.** Sur l'Ozokerite. *Ann. Soc. Géol. Nord*, t. xi, pp. 253-258. [1884.]
3116. **Hasskarl, J. K.** Reise nach dem Berge von Djapara und den Schlammvulkanen von Kuwu. *Flora*, bd. xxx, pp. 641-656. [1847.]
3117. **Hatchett, C.** Observations on Bituminous Substances with a description of the Varieties of the Elastic Bitumen. *Trans. Linn. Soc.*, vol. iv, pp. 129-154. [1798.]
3118. ——— Observations on the Change of some of the Proximate Principles of Vegetables into Bitumen; with Analytical Experiments on a peculiar Substance which is found with the Bovey Coal. *Phil. Trans.*, vol. xciv, pp. 385-410. [1804.]
3119. ——— Observations on the Pitch Lake in the Island of Trinidad, with Analysis of the Mineral Bitumen. *Trans. Linn. Soc.*, vol. viii, pp. 255-259. 1807.
3120. **Hatton, J.** The New Ceylon, being a Sketch of British Borneo or Sabah, from official and other sources of information. 8vo, *London*, 1881.
3121. ——— North Borneo. Explorations and Adventures on the Equator. 8vo, *London*, 1885.
- Haudouin, H.**, see **Soulié, E.**
3122. **Hauer, F. R. v.** Ueber die geologische Beschaffenheit des Körösthales im östlichen Theile des Biharar Comitates in Ungarn. *Jahrb. k.-k. Geol. Reichs.*, bd. iii, pp. 15-35, pl. I (map). [1862.]
3123. ——— Die Geologie und ihre Anwendung auf die Kenntniss der Bodenbeschaffenheit der öster-ungarischen Monarchie. 8vo, *Vienna*, 1875.
3124. **Hauer, F. R. v.**, and **F. F. v. Richtofen.** Bericht über die geologische Uebersichts-Aufnahmen im noröstlichen Ungarn im Sommer 1858. *Jahrb. k.-k. Geol. Reichs.*, bd. x, pp. 399-465. [1859.]
3125. **Hauer, F. R. v.**, and **G. Stache.** Geologie Siebenbürgens. 8vo, *Vienna*, 1863.
3126. **Hauer, K. v.** Arbeiten in dem chemischen Laboratorium der k.-k. geologischen Reichsanstalt. *Jahrb. k.-k. Geol. Reichs.*, bd. ix, pp. 572-574. [1859.]
3127. **Hauff, I.** Ueber die Feuergefährlichkeit des Schieferöls. *Geuerbebl. Wurtt.*, 1863, pp. 467, 468.
3128. **Haupt, G.** Die Petroleumgewinnung in West Galizien, und die Erfolge der dort arbeitenden Amerikaner. *Berg-Hütt. Zeit.*, bd. xlv, pp. 169-177, pl. iv. [1885.]
3129. **Haupt, H.** Level Notes and Compass Courses of the Seaboard Oil Pipe Line, from the mouth of Black Fox Run, in Clarion County, Pa., to Patapsco River, near Baltimore, Md. *Proc. Amer. Phil. Soc.*, vol. xvii, pp. 136-144. [1878.]
3130. ——— On Water Gas from Coal and Petroleum. *Amer. Gaslight Journ.*, vol. xxxii, pp. 75-78. [1880.]
3131. **Hausbrand, E.** Verdampfen, Kondensieren und Kühlen. Ed. II. 8vo, *Berlin*, 1900.
3132. **Hausmann, J.** Die Untersuchung von schwarzen, regenerierten Schwefelsäuren. *Petroleum Zeitschr.*, bd. vi, pp. 2301-2303. [1911.]
3133. ——— Einiges über die Verwendung von Abfallungen zum Verlangen von Petroleum. *Ibid.*, bd. vii, pp. 13-15. [1911.]
3134. **Hausmann, J.**, and **S. Pilat.** Studien über die Oxidation der Petrolkohlenwasserstoffe. *Compt. Rend. Congr. internat. Pétróle*, sess. 3, t. II, pp. 579-598. [1910.]
- Hausmann, J.**, see **Zaloziecki, R.**
3135. **Hausmann, J. F. L.** Handbuch der Mineralogie. 3 Bde. 8vo, *Göttingen*, 1813.
3136. ——— Uebersicht der jüngeren Flötzgebilde im Flussgebiete der Weser. 8vo, *Göttingen*, 1824.
3137. ——— Bemerkungen über Gyps und Karstenit. *Abh. k. Ges. Wiss. Göttingen*, bd. iii, pp. 55-98. [1846.]
3138. **Haus, C. F.** Dutch Natural Gas. *Metal Worker*, Jan. 17, 1903, p. 46.
3139. **Haushausen, —.** Transcaucasia. Notes on Family and Social Life and Condition of the People living between the Black Sea and the Caspian. *St. Petersburg*, 1857.
3140. **Hauthal, R.** Notas sobre algunas Observaciones geológicas en la Provincia de Mendoza. *Rev. Mus. La Plata*, t. vii, pp. 69-96, 4 pls, 3 maps. [1895.]
3141. **Hauthal, R.**, **J. Salas, R. Zuber, J. A. Villalonga, J. J. Kyle**, and **P. N. Arata.** Informe sobre el Descubrimiento de Carbon de Piedra de San Rafael (Provincia de Mendoza, R.A.). *Ibid.*, t. iv, pp. 101-136. [1895.]
3142. **Hauptick, E. de.** The New Russian (Maikop) Naphtha Area. *Min. Journ.*, vol. lxxxviii, pp. 133, 134, 238, 239, 267-269. [1910.]
3143. ——— The Maikop Oilfields To-day. *Ibid.*, vol. lxxxix, pp. 432, 433, 619, 620. [1910.]
3144. ——— Maikop and the Oil Boom. *Ibid.*, pp. 476- [1910.]
3145. ——— The Origin and Formation of the Petroleum Deposits in the Maikop Basin, and the Determination of their Extent. *Ibid.*, pp. 680-682, 781. [1910.]
3146. ——— Independence of British Companies on the Maikop Field. *Ibid.*, p. 813. [1910.]
3147. ——— Maikop and Grozny. *Ibid.*, vol. xc, pp. 841, 842. [1910.]
3148. ——— Oil as Fuel in Russia. *Ibid.*, pp. 872. [1910.]
3149. ——— The Uchta Oil Field, North Russia. *Ibid.*, p. 905. [1910.]
3150. ——— Foreign Companies in Maikop. A Serious Question. *Ibid.*, pp. 993, 994. [1910.]
3151. ——— Russian Law and the Petroleum Industry. *Ibid.*, vol. xci, p. 1275. [1910.]
3152. ——— Maikop: the Position To-day. *Ibid.*, pp. 1301-1303. [1910.]
3153. ——— Crisis in the Baku and Grozny Oil District. *Ibid.*, pp. 1309, 1310. [1910.]
3154. ——— Russia. *Ibid.*, pp. 1337, 1359, 1360, 1386, 1416, 1417, 1489, 1490. [1910.]
3155. ——— Maikop To-day. *Ibid.*, pp. 1386, 1387. [1910.]
3156. ——— The Saghallen Oilfields. *Ibid.*, pp. 1387, 1388. [1910.]
3157. ——— Liquid Fuel for Aeronautics. *Mining Journ.*, vol. xcii, p. 64. [1911.]
3158. ——— The Lesser Russian Oilfields. *Ibid.*, p. 65. [1911.]
3159. ——— The Water Problem in the Maikop Wells. *Ibid.*, p. 92. [1911.]



3160. **Hauptick, E. de.** Cheleken Oil Field. *Mining Journ.*, vol. xcii, pp. 133, 134. [1911.]
3161. ——— Maikop. *Ibid.*, p. 134. [1911.]
3162. ——— Maikop; Stages of Development. *Ibid.*, pp. 161, 162. [1911.]
3163. **Hauy, R. J.** *Traité de Minéralogie*. 4 Tt. and Atlas. 8vo, Paris, 1801.
3164. **Havenor, H. E.** The Oil Fields of Byron, Wyoming. *Salt Lake Min. Rev.*, Jan. 13, 1911.
3165. **Hawes, G. W.** On Diabantite, a chlorite occurring in the trap of the Connecticut Valley. *Amer. Journ.*, ser. 3, vol. ix, pp. 454-457 [1875.]
3166. **Hawkins, —.** On the Tar Springs of Zante. Art. 1 of Robert Walpole's "Travels in various Countries of the East." 4to, London, 1820.
3167. **Hawkins, P.** Pumping by Oil Engines. *Proc. Inst. Civ. Eng.*, vol. clxxvi, pp. 308-316. [1909.]
3168. **Haworth, E.** Oil and Gas in Kansas. [2 papers.] *Proc. Amer. Assoc.*, vol. xliii, pp. 229-236. [1894.]
3169. ——— Oil and Gas in Kansas (preliminary). *Univ. Geol. Surv. Kansas*, vol. i, pp. 232-245. [1896.]
3170. ——— Annual Bulletins on Mineral Resources of Kansas for 1897 and 1898. 8vo, Lawrence, Ks., 1898, 1899
3171. ——— Special Report on Coal. *Univ. Geol. Surv. Kansas*, vol. iii. 8vo, Topeka, 1898.
3172. ——— Mineral Resources of Kansas, 1898. *Bull. Univ. Geol. Surv. Kansas*, 1899.
3173. ——— Petroleum and Natural Gas in Kansas. *Eng. Min. Journ.*, vol. lxxii, p. 397. [1901.]
3174. ——— The Chanute Oil-Fields in Kansas. *Ibid.*, vol. lxxiv, pp. 477, 478. [1902.]
3175. ——— Oil and Gas in Kansas and Indian Territory. *Ibid.*, vol. lxxix, pp. 42, 43. [1905.]
3176. ——— Oil and Gas Development in the Mid-Continental Field in 1905 and 1906. *Min. Ind.*, vol. xiv, pp. 478-485; vol. xv, pp. 623-627. [1906, 1907.]
3177. ——— Natural Gas. Kansas and Oklahoma. *Ibid.*, vol. xvi, pp. 728-732; vol. xvii, pp. 658-661. [1908, 1909.]
3178. ——— Prospecting for Oil and Gas. *Proc. Amer. Min. Congr.*, sess. x, pp. 247-255. [1908.]
3179. ——— Oil and Gas in the Mid-Continental Field. *Eng. Min. Journ.*, vol. lxxxix, pp. 132, 133; vol. xci, pp. 91, 92; vol. xcii, p. 95. [1910-1912.]
3180. **Haworth, E., J. Bennett, H. P. Cady, D. F. McFarland, F. W. Bushong, J. W. Beede, A. F. Rogers, and E. H. Sellards.** Special Report on Oil and Gas. *Kansas Univ. Geol. Surv.*, vol. ix. Pp. xiv, 586; 107 pls., map. [1908.]
- Haworth, E.**, see **Adams, G. I.**
3181. **Hay, O. P.** The Northern Limit of the Mesozoic Rocks in Arkansas. The Mesozoic Border across Pike County. *Ann. Rep. Geol. Surv. Arks.*, 1888, vol. ii, pp. 278-284.
3182. **Hay, R.** Natural Gas in Eastern Kansas. *Fifth Biennial Rep. State Board Agric.* [Kansas]. [1886.]
3183. **Hay, R. D.** Report for the years 1890-1894 on the Trade of Tunis and Beyrout. *Dipl. Cons. Rep.*, ann. ser., nos. 932, 1109, 1626. [1891-1895.]
3184. **Hay-Newton, —.** Report for the year 1899 on the Trade of Algeria. *Ibid.*, ann. ser., no. 2472. [1900.]
3185. **Hayden, F. V.** Third Annual Report of the United States Geological Survey of the Territories, embracing Colorado and New Mexico. 8vo, Washington, 1869.
3186. ——— Preliminary Report of the United States Geological Survey of Wyoming and portions of contiguous Territories (being a second Annual Report of Progress). *Washington*, 1871.
3187. **Hayes, A. A.** Description and Analysis of a new kind of Bitumen [from Utah]. *Proc. Boston Soc. Nat. Hist.*, vol. x, pp. 306, 307. [1866.]
3188. **Hayes, C. W.** Some Facts and Theories bearing on the Accumulation of Petroleum. *Science*, n.s., vol. xvi, p. 1023. [1902.]
3189. **Hayes, C. W.** Asphalt Deposits of Pike County, Ark. *Bull. U.S. Geol. Surv.*, no. 213, pp. 353-355. [1902.]
3190. ——— Leasing Public Oil Lands. *Eng. Min. Journ.*, vol. lxxxviii, p. 1265. [1909.]
3191. **Hayes, C. W., and W. Kennedy.** Oil Fields of the Texas-Louisiana Gulf Coastal Plain. *Bull. U.S. Geol. Surv.*, no. 212. Pp. 174, 11 pls. [1903.]
3192. **Hayes, C. W., T. W. Vaughan, and A. C. Spencer.** Report on a Geological Reconnaissance of Cuba made under the Direction of General Leonard Wood, Military Governor. *U.S. Geol. Surv.*, 1901.
3193. **Hayes, J.** Inspector of Coal Mines Report. *Rep. Mines N. Zealand*, 1900 C. 3a, pp. 29; 1901, C. 3a, pp. 29.
3194. **Hayes, P.** Account of the Inflammable Springs of Ontario County. *New York Medical and Physical Journal*, vol. iii, p. 49. [1824.]
3195. **Hayes, S. D.** On the Destructive Distillation of Light Petroleum Naphthas at comparatively low temperatures. *Amer. Journ.*, ser. 3, vol. ii, pp. 184-188. [1871.]
3196. ——— On the History and Manufacture of Petroleum Products. *Amer. Chem.*, vol. ii, pp. 401-404. [1872.]
3197. **Haywood, H., and H. Lethby.** Report on the Results of Experiments to ascertain the Consumption of Gas at the public lamps, and on the application of the carburetting process, etc. *London*, 1862.
3198. **Headlam, E. J.** A New Island in the Bay of Bengal. *Geogr. Journ.*, vol. xxix, pp. 430-436. [1907.]
3199. **Healde, T.** On the Use of Oleum Asphalti in Ulcers of the Intestines, Lungs, and Viscera. 8vo, London, 1769.
- Healey, H. R.**, see **Gill, A. H.**
3200. **Hearn, W. R.** Report for the year 1895 on the Trade of Cadiz. *Dipl. Cons. Rep.*, ann. ser., no. 1799. [1896.]
3201. ——— Report for the year 1907 on the Trade, etc., of the States of California, Nevada, Utah, and Arizona. *Ibid.*, no. 3998. [1908.]
3202. ——— Reports for the years 1908, 1909 on the Trade of the Consular District of San Francisco (Cal.). *Ibid.*, nos. 4227, 4459. [1909, 1910.]
3203. **Heathcote-Smith, C. E.** Report on the Trade of Smyrna for the year 1910 to June 1911. *Dipl. Cons. Rep.*, ann. ser., no. 4809. [1911.]
- Hebe, P.**, see **Wiebe, H. F.**
3204. **Hébert, E.** Recherches sur l'âge des grès à combustibles d'Helsingborg et d'Höganäs (Suède méridionale). *Ann. Sci. Geol.*, t. i, pp. 117-148. [1869.]
3205. ——— Documents sur la géologie du bassin du Mackenzie recueillis par le Père Petitot. *Bull. Soc. Géol. France*, sér. 3, t. iii, pp. 87-93. [1875.]
3206. **Hébert, E., and E. Munier-Chalmas.** Nouvelles recherches sur les Terrains Tertiaires du Vicentin. *Compt. Rend.*, t. lxxxvi, pp. 1310-1314, 1486-1489. [1878.]
3207. **Heck, F.** Some Applications of Liquid Fuel. *Petrol. Rev.*, vol. xii, pp. 9, 10. [1905.]
3208. **Heck, J. H.** Notes on Experiments with Inflammable and Explosive Atmospheres of Petroleum Vapour. *Trans. Inst. Naval Archit.*, vol. xxxiii, pp. 253-264. [1892.]
3209. ——— Detection of Petroleum Vapour. *Trans. Inst. Eng. Shipb. Scod.*, vol. liv, pp. 53-63. [1910.]
3210. **Hecker, J.** Das Bergöhl in Galizien. *Jahrb. k.-k. Polyt. Inst. Wien*, bd. ii, pp. 335-342. [1820.]
3211. **Hector, J.** First General Report on the Coal Deposits of New Zealand. *Rep. Geol. Surv. N. Zealand*, 1865, pp. 46.
3212. ——— Fourteenth Annual Report of the Colonial Museum and Laboratory [of New Zealand]. 8vo, Wellington, 1879.
3213. **Hector, J., W. Skey, and H. E. Rice.** Further Memoranda respecting Petroleum in New Zealand. *Rep. Geol. Surv. N. Zealand*, 1866-1867, pp. 19-29, map.
3214. **Heddie, M. F.** Minerals new to Britain. *Min. Mag.*, vol. v, pp. 1-25. [1884.]

3215. **Hedinger, J. M.** Short Description of Castleton in Derbyshire; its natural curiosities, and mineral productions. 12mo, *Castleton*, 1760.
3216. **Heeren**, —. Benzol und Benzin. *Mith. Gewerbeber. Hannover*, 1876, pp. 104–107.  
**Heeren, F.**, see **Karmarsch, K.**
3217. **Hefter, G.** Fortschritte der Oel und Fett-Industrie im Jahre 1909. *Chem.-Zeit.*, bd. xxxiv, pp. 837, 838, 846–848, 855, 856, 866–868, 874, 875. [1910.]
3218. —. Technologie der Fette und Oele. 3 Bde. 8vo, *Berlin*, 1906–1910.
3219. **Heiduschka, A.** Beiträge zur Chemie und Analyse der Fette. *Chem.-Zeit.*, bd. xxxiv, p. 558. [1910.]
3220. **Heine, G.** Ueber die Zusammensetzung eines brennbaren Fossils von der Grube Braune Caroline bei Helbra. *N. Jahrb.*, 1845, pp. 149–152.
3221. **Heinhold, M.** Ueber die Entstehung des Pyropissits. *Jahrb. k. preuss. geol. Landesanst.*, bd. xxvii, pp. 114–158. [1906.]
3222. **Heinrich, O. J.** The Mesozoic Formation in Virginia. *Trans. Amer. Inst. Min. Eng.*, vol. vi, pp. 227–274, map and sections. [1879.]
3223. **Heinrich, W.** Ueber Entschwefelungsversuche von Mineralölen. *Zeitschr. angew. Chem.*, bd. x, pp. 8–10. [1897.]
3224. —. Versuche zur Verwerthung der Abfallschwefelsäure der Mineralölindustrie und zur Wiedergewinnung des Natriums aus Kreosotnatrium. *Zeitschr. angew. Chem.*, bd. xi, pp. 525, 526. [1898.]
3225. **Heintz, W.** Ueber die Destillationsprodukte der Stearinsäure. *Zeitschr. Ges. Nat.*, bd. v, pp. 111–124. [1855.]
3226. **Heintzberg, F.** Feuerungsanlage für flüssige Brennstoffe. *Zeitschr. Dampf.-Masch.-Betr.*, bd. xxix, pp. 205, 206. [1906.]
3227. **Heinzerling, C.** Petroleum und Leuchtgas. *Halle*, 1885.
3228. **Heise**, —. Die Staubbildende Fussbodenöle. 8vo, *Berlin*, 1909.
3229. **Helbing, K.** Untersuchung eines neuen Erdharzes. *Ann. Chem. Pharm.*, bd. cixxii, pp. 297–303. [1874.]
3230. **Helfers, F.** Bestimmung der Vergasungswertes von Mineralölen. *Zeitschr. angew. Chem.*, bd. ix, pp. 650–654. [1896.]
3231. **Hell, C.** Ueber den Fichtelöl. *Ber. deutsch. chem. Ges.*, bd. xxii, pp. 498–502. [1889.]
3232. **Hell, C.**, and **E. Medinger.** Ueber das Vorkommen und die Zusammensetzung von Säuren im Rohpetroleum. *Ber. deutsch. chem. Ges.*, bd. vii, pp. 1216–1223. [1874.]
3233. —, —. Ueber die Oxydation der im Rohpetroleum enthaltenden Säure,  $C_{11}H_{20}O_2$ . *Ibid.*, bd. x, pp. 451–456. [1877.]
3234. **Helland, A.** Bergbez, Anthracit und nogle andre Koldholdige Mineralien fra Ertelesteder og Granitgango. *Geol. Fören. Stockh. Förh.*, bd. ii, pp. 513–522. [1875.]
3235. **Heller, G.** Der Abel'sche Petroleumprober. *Mon. Mith. Ver. Frankfurt Ober.*, bd. i, pp. 53–58, 75–77. [1884.]
3236. **Hellmann, J. A.** Einiges über die Anwendung des Asphalt und sein Verhalten gegen die Atmosphären. *Berg-Hütt. Zeit.*, bd. vii, pp. 23–25. [1848.]
3237. **Helsing, G.** Skifferoljeindustrien i Skottland och Frankrike. *Seer. geol. Undersök.*, Arsb., 1907, no. 2. Pp. 92, pl. [1906.]
3238. **Helm, O.** Gedanit, ein neues fossiles Harz. *Arch. Pharm.*, ser. 3, bd. xiii, pp. 503–507. [1878.]
3239. —. Schwefelgehalt des Asphalt und anderer Retinalithe. *Ibid.*, pp. 507–514. [1878.]
3240. **Helmersen, G. v.** Mémoire sur le schiste argileux bitumineux d'Esthonie, et sur une nouvelle roche combustible découverte dans cette province. *Ann. Journ. Mines Russ.*, 1838, pp. 97–128.
3241. —. Ueber den bituminösen Thonschiefer und ein neuerdecktes brennbares Gestein der Uebergangsformation Ehtlands, mit Bemerkungen über einige geologische Erscheinungen neuerer Zeit. *Bull. Sci. Ac. Imp. St. Pétersb.*, t. v, pp. 56–73. [1839.]
3242. **Helmersen, G. v.** Die Bohrversuche zur Entdeckung von Steinkohlen auf der Samara-halbinsel und die Naphtha-quellen und Schlammvulcane bei Kertsch und Tamen. *Bull. Sci. Ac. Imp. St. Pétersb.*, t. xi, pp. 158–195, pl. [1867.]
3243. —. [The Development of the Oil-fields of Kertsch and Tamen.] *Gorn. Journ.*, 1864, t. 4, pp. 51–59.
3244. **Heimbacher, R.** Naphta und Ozokerit in Galizien. *Berg-Hütt. Zeit.*, bd. lvi, p. 11. [1897.]
3245. —. Die nutzbaren Lagerstätte Periens. *Zeitschr. prakt. Geol.*, bd. vi, pp. 420–432. [1898.]
3246. —. The Useful Minerals of Turkey. *Eng. Min. Journ.*, vol. lxxvi, pp. 635, 636. [1898.]
3247. **Heimbacher, W.** Uebersicht der geognostischen Verhältnisse der Rossitz-Oslawaner Steinkohlenformation. *Jahrb. k.-g. Geol. Reichs.*, bd. xvii, pp. 447–460, pl. iii (map). [1866.]
3248. —. Mineralspecies der Rossitz-Oslawaner Steinkohlenformation. *Ibid.*, bd. xvii, pp. 195–210. [1867.]
3249. **Hempel, H.** Ueber Gasöle und Ölgas. *Journ. Gasbel.*, bd. liii, pp. 53–58, 77–82, 101–103, 137–141, 155–165. [1910.]
3250. **Hempel, W.** Ueber Leuchtgasdarstellung in Amerika. *Ibid.*, bd. xxxvi, pp. 465–479, 492–493. [1893.]
3251. —. Ueber die Bestimmung der Verbrennungswärme der Heizmaterialien. *Zeitschr. angew. Chem.*, bd. ix, pp. 350–352. [1896.]
3252. **Henckel, J. F.** Pyritologia, oder Kiesz-Historie. 8vo, *Leipsig*, 1725.
3253. **Henderson**, —. Excursions and Adventures in New South Wales, etc. . . . 2 vols. 8vo, *London*, 1851.
3254. **Henderson, J.** Observations on the Salt of Bitumen, the Bit-Nobin of the Hindoos. *Phil. Mag.*, vol. xiv, pp. 206–209. [1802.]
3255. **Henderson, J. B.** Some Abnormal Rorewaters. *Rep. Austral. Assoc.*, vol. x, pp. 139, 140. [1905.]
3256. **Henderson, McC.** Les concessions pétrolifères Taylor-Coryell à Madagascar. *Journ. Pét.*, t. ix, pp. 148–153. [1909.]
3257. **Henderson, N. M.** Shale retorts at Broxburn. *Journ. Soc. Chem. Ind.*, vol. xviii, pp. 246–248. [1899.]
3258. —. The Recovery of Waste Gases from Mineral Oil Still. *Ibid.*, vol. xxx, pp. 268, 269. [1911.]
3259. **Hendrich, F. L.** Der gegenwärtige Stand der Tiefbohrtechnik in Deutschland. *Naphta*, bd. x, pp. 43–46, 83–85, 149–153, 273–278, 295–300, 1 pl. [1902.]
3260. **Hennen, R. V.** Marshall, Wetzel and Tyler Counties. *W. Virginia Geol. Surv.*, vol. ii. Pp. 654; 12 pls. [1909.]
3261. **Henriques, R.** Quantitative Trennung von Steinkohlentheer- und Petroleum-Kohlenwasserstoffen. *Chem.-Zeit.*, bd. xix, pp. 958, 959. [1895.]
3262. —. Die schottische Schieferöl-Industrie. *Chem. Rev. Fett-Ind.*, bd. v, pp. 61–64, 81–86, 108–112, 125–129. [1898.]
3263. **Henriavaux, J.**, see **Coquillion, J. J.**
3263. **Henry, A.** Les Transports des Pétoles. *Compt. Rend. Congr. internat. Pétrole*, sess. 3, t. ii, pp. 853–868. [1910.]
3264. **Henry, A.**, see **Arbel**, —
3264. **Henry, H.** Note sur le Pays de l'Huile de l'Amérique du Nord. *Bull. Soc. Industr. Min.*, sér. 2, t. vii, pp. 135–143. [1878.]
3265. **Henry, J. D.** Baku: an Eventful History. 8vo, *London*, 1905.
3266. —. Thirty-five Years of Oil Transport; the Evolution of the Tank Steamer. 4to, *London*, 1907.
3267. —. Oil Fuel and the [British] Empire. 8vo, *London*, 1908.
3268. —. Oil Fields of New Zealand, with some critical notes on the Colonial Situation of To-day. 4to, *London*, 1911.
3269. —. John Bull and his Oil Fields. *London*, 1912.
3270. **Henry, J. T.** The Early and Later History of Petroleum, with authentic facts in regard to its development in Western Pennsylvania . . . 8vo, *Philadelphia*, 1875.

3271. **Henry, O.** Analyse comparative de deux bitumes élastiques d'Angleterre et de France [Castleton, Montrelais]. *Journ. Chim. Méd.*, t. i, pp. 18-27. [1825.]
3272. **Henry, P. W.** Some Facts Relating to the Asphalt Paving Industry. *Eng. News*, vol. xlv, pp. 182-186. [1901.]
3273. **Henry, T. A.** Petroleum Industry of Canada. *Bull. Imp. Inst.*, vol. i, pp. 98-100. [1903.]
3274. ——— Asphalt Rock from the Island of Bahrein (Persian Gulf). Analysis by G. S. Blake. *Ibid.*, pp. 116-118. [1903.]
3275. ——— Petroleum from Trinidad. *Ibid.*, pp. 177-180. [1903.]
3276. ——— Natural Pitch or Manjak from Trinidad. *Ibid.*, pp. 180-182. [1903.]
3277. **Henry, T. A., and G. S. Blake.** Report on the Principal Petroleum Resources of the British Empire. I. Canada. *Bull. Imp. Inst.*, vol. i, pp. 183-187. [1903.]
3278. **Henry, W.** Experiments on the gases obtained by the destructive distillation of wood, peat, pit-coal, oil, wax, etc., with a view to the theory of their combustion, when employed as sources of artificial Light; and including observations on hydrocarbons generally and the carbonic oxide. *Journ. Nat. Phil. Chem. Arts*, ser. 2, vol. xi, pp. 65-74. [1805.]
3279. ——— Description of an Apparatus for the Analysis of the compound inflammable Gases by slow combustion, with Experiments on the Gas from Coal, explaining its application. *Phil. Trans.*, vol. xcviij, pp. 282-303. [1808.]
3280. ——— Experiments on Ammonia, and an account of a New Method of Analysing it, by Combustion with Oxygen and other Gases. *Ibid.*, vol. xcix, pp. 430-449. [1809.]
3281. ——— On the aëriform compounds of Charcoal and Hydrogen; with an account of some additional experiments on the gases from oil and from coal. *Ibid.*, 1821, pp. 136-161.
3282. **Henwood, E. N.** Re Liquid Fuel. *Marine Engineer*, vol. viii, pp. 24, 25. [1886.]
3283. **Heppé, G.** Prüfung des Petroleums auf Verfälschung mit Solköl. *Ind.-Bl.*, bd. xx, p. 406. [1884.]
3284. **Herapath, T. J.** The Torbanehill Mineral. *Chemist*, ser. 3, vol. i, pp. 207, 208. [1854.]
3285. **Herapath, W.** Analysis of White Coal or Bituminous Sand, from Australia [Tasmania]. *Trans. N. Engl. Inst. Eng.*, vol. iv, p. 191. [1856.]
3286. **Herbelot, B. d'.** Bibliothèque Orientale, ou Dictionnaire Universel; contenant généralement tout ce qui regarde la Connaissance des Peuples de l'Orient . . . . fo., Paris, 1697.
3287. **Herbert, A.** [Persian Petroleum.] *Commercial Reports Foreign Office*, 1885, no. 20.
3288. **Herbert, G. H.** Oil Engines. *Proc. Assoc. Eng. Charge*, vol. x, no. 1. Pp. 24. [1904.]
3289. **Herbert, J. D.** On the Mineral Productions of that Part of the Himalaya Mountains lying between the Satlaj and the Kali (Gagra) Rivers; considered in an economical Point of View, including an Account of the Mines, and Methods of working them, with Suggestions for their Improvement. *As. Res.*, vol. xviii, pp. 227-258. [1833.]
3290. **Herbert, Thos.** A Relation of some Years' Travels into Africa and the Great Asia; especially the Territories of the Persian Monarchy and some parts of the Oriental Indies and Isles adjacent. Fo., London, 1634.
3291. **Herbich, F.** Neue Beobachtungen in den öst-bienbürgischen Karpathen. *Verh. k.-k. geol. Reichs.*, 1873, pp. 282-285.
3292. ——— [Mining and Geological Observations in Eastern Transylvania.] *Erdélyi Museum*, 1877.
3293. ——— [Petroleum Occurrences in Szeklerland.] *Orros-Termesz. Ertcs.*, köt. vi, 1881.
3294. **Herbig, W.** Zur Bestimmung des Flammpunktes der Mineralöle. *Chem. Rev. Fett-Harz-Ind.*, bd. xii, pp. 26-80. 1905.
3295. **Herbig, W.** Jahresbericht an dem Gebiete der Fette und Öle für das Jahr 1904[1910]. *Chem. Rev. Fett-Harz-Ind.*, bd. xii, pp. 44-48, 76-77, 96-98, 122-125, 152-154; bd. xiii, pp. 44-47, 76-79, 99-103, 126-130, 154-157; bd. xiv, pp. 28-31, 47-50, 72-76, 100-105, 128-132, 156-160; bd. xv, pp. 44-46, 72-77, 100-103, 128-132, 156-159, 184-189; bd. xvi, pp. 48-51, 79-83, 100-104, 129-132, 162-165, 182-186, 218-223; bd. xvii, pp. 28-33, 40-45, 67-72, 94-98, 121-126, 148-150; bd. xviii, pp. 70-75, 98-101, 126-129, 154-158, 179-181, 207-210, 234-238, 262-264. [1905-1911.]
- Herde, J.** see **Heusler, F.**
3296. **Hericaert de Thury, —.** Notice sur les mines d'asphalte, bitume et lignite de Lobsann. Paris, 1838.
3297. **Heringa, Jod.** Onderzoek van een monster aardolie uit de afdeling Lematang-lilr van de residentie Palembang, ingezonden door den Heer Streif. *Nat. Tijdschr. Ned. Ind.*, dl. xxxvii, pp. 241-246. [1877.]
3298. **Herman, —.** Die Industrie-Ausstellung zu Paris im Jahre 1839. Nürnberg, 1840.
3299. **Hermann, L.** Ueber Gesetzmässigkeiten und Berechnung der Verbrennungswärme organischer Verbindungen. *Zeitschr. Chem.*, bd. xii, pp. 472-477. [1869.]
3300. **Hermann, R.** Ueber Neftegedil, Bakerit und Asphalt. *Bull. Soc. Imp. Nat. Mosc.*, t. xxx, pp. 470-489. [1857.]
3301. ——— [Asphalt on the Little Tchetchne.] *Gorn. Journ.*, 1858, t. 2, pp. 181-185.
3302. **Hermstadt, S. F.** Chemisches Vergleichender des Wassers aus dem Todten Meer, des aus dem Jordan, des bituminösen Kalks und eines andern Fossils aus der Nachbarschaft des Todten Meeres. *Abh. k. Ak. Wiss. Berlin*, 1820-1821, pp. 63-92.
3303. **Hermite, E.** [Petroleum in the Argentine Republic.] *Anales Minist. Agric. Repub. Argent.*, t. i, pp. 125-131. [1905.]
3304. **Herouard, —.** Note sur la degré d'inflammabilité de quelques hydrocarbures. *Journ. Chim. Méd.*, t. iii, pp. 629-632. [1867.]
3305. **Herr, V. F.** [Determination of Benzene and Homologues in the Light Fractions of Grozni Petroleum.] *Trudi Bak. Otd. Imp. Russk. Tekhn. Obsch.*, kn. xxii, Jan., p. 22. [1907.]
3306. ——— [Quantitative Determination of Benzene and Homologues in Bibi-Eibat Oil.] *Ibid.*, March 1907, pp. 8-6.
3307. ——— Ein neuer Dephlegmator für Naphtha-Fraktiomerung. *Chem.-Zeit.*, bd. xxiii, pp. 148, 149. [1908.]
3308. ——— Zur Kenntnis der Filtration von Baku-Erdölen durch Fullererde. *Petroleum Zeitschr.*, bd. iv, pp. 1284-1287. [1909.]
3309. ——— Nochmals; Zur Filtrationsfrage der natürlichen Erdöle. *Ibid.*, bd. v, p. 1387. [1910.]
3310. ——— [Formation of Dibasic Fatty Acids of the Oxalic Acid Series by Oxidising Fractions of Baku Petroleum with Nitric Acid.] *Trudi Bak. Otd. Imp. Russk. Tekhn. Obsch.*, 1909.
3311. ——— Ueber die Kondensation von Erdöl und seinen Destillation mit Methylal und Schwefelsäure. *Chem.-Zeit.*, bd. xxiv, pp. 893, 894. [1910.]
- Herr, V. F., see Predit, A. T.**
3312. **Herrmann, F.** Ueber das Problem, die Anzahl der isomeren Paraffine der Formel  $C_nH_{2n+2}$  zu bestimmen. *Ber. deutsch. chem. Ges.*, bd. xiii, p. 792. [1880]; bd. xxx, pp. 2423-2426. [1897.]
3313. **Herrmann, G.** Gewinnung und den Transport des Petroleums in den Oelregionen Pennsylvaniens. *Wochenschr. Ver. Deutsch. Ing.*, 1880, pp. 393, 394.
3314. **Hertor, P.** Beitrag zur Charakteristik der Thüringisch-Sächsischen Braunkohlenformation. *Abh. nat. Ges. Halle*, bd. iv, pp. 39-85. [1858.]
3315. **Herting, O.** Die brauchbaren Methoden zur Bestimmung des Schwefels im . . . Asphalt . . . und Gasreinigungsmasse. *Chem.-Zeit.*, bd. xxiii, pp. 768, 769. [1899.]
3316. **Hertsenstein, V. O.** [The Preservation of Wood, and particularly of Sleepers, from Destruction by Insects and from Rotting.] *Zap. Imp. Russk. Tekhn. Obsch.*, g. xli, y. 4-5, pp. 134-170; v. 7-8, pp. 78-113; v. 9, pp. 68-94; v. 11, pp. 45-116, 3 pls. [1887.]

3317. **Hertzog, B.** Chronicon alsatia, Edelsasser Cronick und ausführliche Beschreibung des untern Rhesasses am Rheinstrom. *Strasbourg*, 1592.
3318. **Herzfeld, H.** Zur Trennung der Mineralöle von Terpentinöl und Harzöl. *Zeitsch. öffentl. Chem.*, bd. viii, pp. 446, 447. [1902.]
3319. **Hess, H.** Mémoire sur quelques produits pyrogénés. *Mém. Ac. Sci. St. Pétersb.*, sér. 6, t. iii, pp. 297-312, 389-400, 527-536. [1855.]
3320. ——— Beleuchtung einiger streitigen Punkte über Euplon und Bergnaphtha. *Ann. Phys. Chem.*, bd. cxiv, pp. 163-171. [1836.]
3321. ——— Composition du Gaz des feus de Bakou. *Bull. Sci. St. Pétersb.*, t. I, pp. 166, 167. [1836.]
3322. **Hessel, J. F. C.**, and **C. Kopp.** De l'Asphalte des Mines du Val de Travers. *Act. Soc. Helv.*, 1855, pp. 154-168.
3323. **Heude, W.** A Voyage up the Persian Gulf and a Journey overland from India to England, in 1817. *London*, 1819.
3324. **Heumann, C.** Beiträge zur Theorie leuchtender Flammen. *Ann. Chem. Pharm.*, bd. cxix, pp. 129-153; bd. cxix, pp. 1-29; bd. cxix, pp. 102-141. [1876.]
3325. ——— Hochsiedendes Petroleum als Leuchtmaterial, und die Feuergefährlichkeit der Petroleumsorten des Handels. *Polyt. Journ.*, bd. ccxiv, pp. 408-414, 525-531. [1877.]
3326. ——— Ueber Petroleumprüfung und einen neuen Prüfungsapparat. *Chem. Ind.*, bd. vii, pp. 188-198. [1884.]
3327. **Heurteau, C. E.** L'Industrie du Pétrole en Californie. *Ann. Mines*, sér. 10, t. iv, pp. 215-249, pl. ix. [1903.]
3328. **Heurteau, G.** Mémoire sur la recherche et l'exploitation du pétrole en Gallicie. *Ann. Mines*, sér. 6, t. xix, pp. 197-264. [1871.]
3329. **Heusler, F.** Beiträge zur Chemie des Braunkohlentheers. *Ber. deutsch. chem. Ges.*, bd. xxv, pp. 1665-1678; bd. xxviii, pp. 488-498. [1892, 1895.]
3330. ——— Ueber die Bestimmung des Schwefels im Petroleum. *Zeitschr. angew. Chem.*, bd. viii, pp. 285, 286. [1895.]
3331. ——— Ueber die Einwirkung von Aluminiumchlorid auf Theer- und Erdölestillate und über die Theorie der Erdölbildung. *Ibid.*, bd. ix, pp. 288-292, 318-321. [1896.]
3332. ——— Ueber die Zusammensetzung der schottischen Schiefertheeröle, ein Beitrag zur Theorie der Theerbildung. *Ber. deutsch. chem. Ges.*, bd. xxx, pp. 2743-2752. [1897.]
3333. **Heusler, F.**, and **M. Dennstedt.** Ueber die neutralen Schwefelsäureester im Petroleum des Handels. *Zeitschr. angew. Chem.*, bd. xvii, pp. 264, 265. [1904.]
3334. **Heusler, F.**, and **J. Herde.** Ueber die Bestimmung des Paraffins im Rohanthracen. *Zeitschr. angew. Chem.*, bd. viii, p. 253. [1895.]
3335. **Hewett, D. F.** Vanadium Deposits in Peru. *Trans. Amer. Inst. Min. Eng.*, vol. xi, pp. 274-299. [1910.]
3336. **Hewitt, J. T.** Note on Natural Gas at Heathfield Station (Sussex). *Quart. Journ. Geol. Soc.*, vol. liv, pp. 572-574. [1898.]
3337. **Heyde, G. v. d.** Zur gefahrlosen Vernichtung der bei der Destillation von Mineralölen, Theorien, Harzen usw. entstehenden Gase. *Chem.-Zeit.*, bd. xxxlii, pp. 126, 127. [1909.]
3338. **Heyden, H. v.** Ueber die geologischen Verhältnisse der Umgegend von Carpano in Istrien. *Jahrb. k.-k. geol. Reichs.*, bd. iv, pp. 546-550. [1853.]
3339. **Heydrick, W. H.** The Kansas Oilfields. *Mining Mag. N. York*, vol. x, pp. 363-375, pl. [1904.]
3340. **Heynemann, C.** [Oil-drilling by Electric Power.] *Monit. Int. Pétr. Roum.*, t. vi, pp. 396-399. [1905.]
3341. **Heyrowsky, E.** Ueber Verwendung von roher Braunkohle beim Hofenbetriebe. *Zeitschr. Berg-Hütt.-Ver. Kärnt.*, bd. vii, pp. 135-142. [1875.]
3342. **Hicks, J. A.** The Laboratory Book of Mineral Oil Testing. 8vo, London, 1906.
3343. **Higgins, W. C.** Oil Operations in Spring Valley Field, Wyoming. *Salt Lake Min. Rev.*, Jan. 30, 1911.
- Higgins, W. F.**, see **Harker, J. A.**
3344. **Higgs, Samuel, Jun.** Notice of an Accumulation of Carburetted Hydrogen or "Firedamp" in the Ding-Dong Mine, situated in the parish of Madron, near Penzance. *Trans. R. Geol. Soc. Cornwall*, vol. ix, pt. 1, pp. 34-37. [1875.]
3345. **Hildebrand, W. F.** The Vanadium Sulphide, Patronite, and its Mineral Associates, from Minasragra, Peru. *Amer. Journ.*, ser. 4, vol. xxiv, pp. 141-161. [1907.]
3346. **Hildebrandt, —.** Die Hamburgische Staatsanwaltschaft und die Vakuum Oil Co. 1909.
3347. **Hildreth, S. P.** Facts relating to certain parts of the State of Ohio. *Amer. Journ.* [ser. 1], vol. x, pp. 1-8. [1826.]
3348. ——— Observations on the Saliferous Rock Formation in the Valley of Ohio. *Ibid.*, vol. xxiv, pp. 46-68. [1833.]
3349. ——— Observations on the Bituminous Coal Deposits of the Valley of Ohio, and the accompanying Rock-strata: with Notices of the Fossil Organic Remains and the Relics of Vegetable and Animal Bodies. *Ibid.*, vol. xxix, pp. 1-154. [1836.]
3350. **Hilgard, E. W.** On the Geology of Lower Louisiana and the Rock-salt Deposit of Petite Anse. *Amer. Journ.*, ser. 2, vol. xviii, pp. 77-88. [1869.]
3351. ——— Summary of Results of a late Geological Reconnaissance of Louisiana. *Ibid.*, vol. xviii, pp. 331-346. [1869.]
3352. ——— On the Geology of the Delta and the Mud-lumps of the Passes of the Mississippi. *Amer. Journ.*, ser. 3, vol. 1, pp. 238-246, 356-358, 425-435. [1870.]
3353. ——— On the Geological History of the Gulf of Mexico. *Ibid.*, vol. ii, pp. 391-404. [1871.]
3354. ——— Supplementary and Final Report of a Geological Reconnaissance of the State of Louisiana. *New Orleans*, 1873.
3355. ——— The Asphaltum Deposits of California. *Min. Res. United States* for 1883 and 1884, pp. 938-948. [1885.]
3356. ——— The Asphaltum Mine of Ventura Asphalt Company. *10th Ann. Rep. State Mineral. California* for 1890, pp. 763-772. [1890.]
3357. **Hilgard, E. W.**, and **C. Zincken.** Die Vorkommen von Erdöl und Asphalt in Californien. *Oesterr. Zeitschr. Berg-Hütt.*, bd. xxv, pp. 4-10. [1887.]
3358. **Hilger, E.** Der Braunkohlen des Bauersberges bei Bischofshelm vor der Rhön. *Ann. Chem. Pharm.*, bd. cxxxv, pp. 211-213. [1877.]
3359. **Hill, B.** The Production of Natural Gas in 1906 [-1907]. *Min. Res. U.S.* for 1906 [-1909]. [1907-1911.]
3360. **Hill, H.** The Oil Prospects of Poverty Bay and District. *Trans. N. Zealand Inst.*, vol. xxi, pp. 320-325, pl. xxiv. [1889.]
3361. ——— Oil Wells and Oil Prospects along the East Coast. *Ibid.*, vol. xxxix, pp. 509-520, pl. xxiv. [1907.]
3362. **Hill, R. T.** Mineral Resources of Porto Rico. *Ann. Rep. U.S. Geol. Surv.*, vol. xx, pt. vi, pp. 771-779. [1899.]
3363. ——— The Beaumont Oil-Field, with Notes on other Oil-Fields of the Texas Region. *Trans. Amer. Inst. Min. Eng.*, vol. xxviii, pp. 363-405. [1902.]
3364. **Hill, R. T.**, and **T. W. Vaughan.** Austin, Texas. *76, U.S. Geol. Survey*, 1902.
3365. **Himstedt, F.** Ueber die radioaktive Emanation der Wasser- und Oelquellen. *Ber. nat. Ges. Freiburg i. Br.*, bd. xiv, pp. 181-189. [1904.]
3366. **Hind, H. T.** The Oil Wells of Canada. *Coll. Guard.*, vol. iii, p. 287. [1862.]
3367. **Hinde, H. Y.** Essais sur la fabrication du gaz d'éclairage au moyen du pétrol. *Ann. Mines*, sér. 6, t. iv, pp. 117-125. [1863.]

3368. **Hinde, H. Y.** A preliminary Report on the Geology of New Brunswick, together with a special Report on the distribution of the "Quebec Group" in the Province. 8vo, *Fredericton*, 1865.
- Hinkins**, —, see **Uren, S.**
3369. **Hirsch, J.** On the Distillation of Hydrocarbons. *Chem. News*, vol. xviii, pp. 51, 52. [1868.]
3370. ——— Tetraclorokohlenstoff im Vergleich zu Benzin bei der Extraktion. *Naphta*, bd. xiii, pp. 311, 312. [1905.]
3371. **Hirsch, J.**, and **L. Hirsch.** Bemerkungen über der Paraffinschalt inländischer Oele. *Chem. Rev. Fett-Harz-Ind.*, bd. i, no. 12, pp. 2, 3. [1895.]
3372. **Hirsch, J. P.** [Effect of Sulphuric Acid in the Distillation of Naphtha.] *Trud. Bakinsk. Otd. Imp. Russk. Techn. Obsch.*, 1889-1891, pp. 64-66. [1892.]
- Hirsch, L.**, see **Hirsch, J.**
3373. **Hirsch, R.** [On the Orthography of "Naphthol," etc.] *Chem.-Zeit.*, bd. xiii, p. 99. [1889.]
3374. **Hirsehi, H.** Zur Geologie und Geographie von Portugiesisch-Timor. *N. Jahrb.*, beil.-bd. xxiv, pp. 460-475, pls. xxxvi, xxxvii. [1907.]
3375. ——— Zur Frage der Entstehung des Erdöls. *Petroleum Zeitschr.*, bd. vii, pp. 62, 63. [1911.]
3376. **Hirt, L.** Die Gasinhalationskrankheiten und die gewerblichen Vergiftungen. In Handbuch der Hygiene und der Gewerbekrankheiten, Th. 2, Abth. 4. *Leipzig*, 1882.
3377. **Hirzel, H.** Die Lagerung von Mineralölen. *Deutsch. Industr.-Zeit.*, 1867, p. 141.
3378. ——— Leuchtgas aus Petroleumrückständen mittelst des Hirzelschen Apparates erzeugt. *Zeitschr. Chem.*, bd. iii, p. 617. [1867.]
3379. ——— Erdöl und Asphalt auf den Inseln Pedernales, Pesquero und del Plata in Venezuela. *Chem. Rev. Fett-Harz-Ind.*, bd. x, pp. 275-277. [1903.]
3380. **Hiscox, G. D.** Gas, Gasoline and Oil-Engines. *London*.
3381. **Hitchcock, C. H.** The Albert Coal or Albertite of New Brunswick. *Amer. Jour.*, ser. 2, vol. xxxix, pp. 267-273. [1865.]
3382. ——— The Geological Distribution of Petroleum in North America. *Rep. Brit. Assoc.*, 1866, sect., pp. 55-57.
3383. **Hitchcock, E.** Notes on the Geology of several parts of Western Asia, founded chiefly on Specimens and Descriptions from American Missionaries. *Rep. Amer. Assoc. Geol. Nat.*, 1840-1842, pp. 348-421. [1843.]
3384. **Hix**, —, Notice sur les huiles de pétrole. *Rép. Chim. Appl.*, t. v, pp. 346-350. [1863.]
3385. **Hochstetter, P. v.** Ueber das Vorkommen von Erdöl (Petroleum) und Ertrachs im Sandeekreise in Westgalizien. *Jahrb. k.-k. geol. Reichs.*, bd. xv, pp. 199-207. [1865.]
3386. **Hock, J.** Petroleum Moter. *Journ. Soc. Arts*, vol. xxii, p. 798. [1874.]
3387. **Hock, M.** Ueber die Nachweisungs- und Bestimmungsmethoden des Paraffins in Stearinkerzen. *Polyt. Journ.*, bd. ccxiii, pp. 313-315. [1872.]
3388. **Hocstovskij, J.** Das österreichische Naphtharecht. *Compt. Rend. Congr. internat. Pétrole*, sess. 3, t. ii, pp. 883, 884. [1910.]
3389. **Hodge, J. T.** Is there Petroleum in California? *Mining Register*, April 8, 1865.
3390. **Hodgetts, E. A. B.** Liquid Fuel. *Trans. Civ. Mech. Eng. Soc.*, 1888-1889, pp. 63-70. [1889.]
3391. ——— Liquid Fuel for Mechanical and Industrial Purposes. 8vo, *London*, 1890.
3392. **Hodgson, E. H.** The Determination of Sulphur in Asphalt. *Journ. Chem. Soc.*, vol. xx, pp. 882-889. [1898.]
3393. **Hodgson, L. H.** The Wolf Safety Lamp. *Eng. Min. Journ.*, vol. lxxxiii, p. 960. [1907.]
3394. **Hodgson, R. M.** Petroleum Deposits in Russian Sakhalin. *Min. Journ.*, vol. lxxxvii, p. 337. [1909.]
3395. **Höfer, Prof. H.** Die Petroleumindustrie Nord-Amerikas in geschichtlicher, wirtschaftlicher, geologischer und technischer Hinsicht. 8vo, *Vienna*, 1876, 1877.
3396. ——— Bericht über die Weltausstellung in Philadelphia 1876. Heft viii. 8vo, *Vienna*, 1877.
3397. ——— Die geologische Verhältnisse der Nord-Amerikanischen Petroleumlager. *Ausland*, 1878, p. 341.
3398. ——— Das Erdöl (Petroleum) und seine Verwandten. Geschichte, physikalische und chemische Beschaffenheit, Vorkommen, Ursprung, Aufindung und Gewinnung des Erdöls. 8vo, *Brunswick*, 1888.
3399. ——— Notizen über das Erdölvorkommen auf der Halbinsel Apsheron (Kaspische See). *Oesterr. Zeitschr. Berg-Hüt.*, bd. xxxvi, pp. 21, 22. [1888.]
3400. ——— Zur Statistik der galizischen Erdöl- und Erdwachs-Industrie. *Ibid.*, p. 192. [1888.]
3401. ——— Zur Entstehung des Erdöles. *Ibid.*, bd. xxxix, pp. 145-148. [1891.]
- 3402 (blank).
3403. ——— Das Tertiar im Nordosten von Friedau in Steiermark. *Jahrb. k.-k. geol. Reichs.*, bd. xlv, pp. 571-582. [1894.]
3404. ——— Zur Geologie des Erdöles. *Oesterr. Zeitschr. Berg-Hüt.*, bd. xviii, pp. 525-527. [1900.]
3405. ——— Die Tiefbohrkunst als Wissenschaft. *Ibid.*, pp. 119-121. [1900.]
- 3406 (blank).
3407. ——— Petroleum. *Naphta*, bd. ix, pp. 268-270, 287-291, 306-308. [1901.]
3408. ——— Erdöl-Studien. *Süz. k. Ak. Wiss. Wien*, bd. cxli, abth. 1, pp. 615-645. [1902.]
3409. ——— Das Erdöl auf den malaischen Inseln. *Oesterr. Zeitschr. Berg-Hüt.*, bd. liii, pp. 15-17, 31-33, 45-47, 62-64, 74-77. [1905.]
3410. ——— Das Erdölvorkommen auf der Insel Zante (Zakynthos). *Ibid.*, pp. 338-340. [1905.]
3411. ——— Die Erdölvorkommnisse von Mesopotamien und Persien. *Petroleum Zeitschr.*, bd. i, pp. 781-786, 819-824. [1906.]
- 3412 (blank).
3413. ——— Die Entstehung der Erdöllagerstätten. *Mitth. geol. Ges. Wien*, bd. ii, pp. 136-147. [1909.]
3414. ——— Zur Wahl der Bohrpunkte in Erdölgebieten. *Compt. Rend. Congr. internat. Pétrole*, sess. 3, t. ii, pp. 162-170. [1910.]
3415. ——— Das leichte Erdöl von Ssurachani bei Baku als Filtrationsprodukt. *Petroleum Zeitschr.*, bd. v, pp. 629, 630. [1910.]
3416. ——— Die Erdöllagerstätten in Alaska. *Ibid.*, pp. 741-746. [1910.]
3417. ——— On the Development of the Anticlinal Theory. Discussion of Paper by M. J. Munn. *Econ. Geol.*, vol. v, pp. 492, 493. [1910.]
3418. ——— The Origin of Petroleum. *Econ. Geol.*, vol. v, p. 561. [1910.]
3419. ——— Der Gasausbruch bei Kissárnás und die Argille seagliose. *Zeitschr. intern. Ver. Bohring. Bohrtechn.*, bd. xix, p. 25. [1912.]
3420. **Höfer, H.**, and **F. Fischer.** Die Mineralölindustrie. 8vo, *Brunswick*, 191-.
- Höfer, H.**, see **Engler, C.**
3421. **Höföf, J. T.** Historia Balsami mineralis Alsatici seu Petroleii vallis Sancti Lamperti. Der hanauische Erd-Balsam, Lamperterslocher Oel, oder Büchel-Brunn. 4to, *Strasburg*, 1734.
3422. **Hoening, J. B.** The Oil and Gas Sands of Kentucky. *Bull. Ky. Geol. Surv.*, no. 1. Pp. 253; 10 pls.; 3 maps. [1905.]
3423. **Hök, H.** Exploration of Bolivia. *Geogr. Journ.*, vol. xxv, pp. 498-511, pl. [1905.]
3424. **Hök, W.** On the Transverse Stability of Floating Vessels containing Liquids, with special reference to ships carrying Oil in Bulk. *Trans. Inst. Naval Arch.*, vol. xxxvi, pp. 332-346, pls. xxxii-xxxv. [1895.]

3425. **Höland, R.** Die Bestimmung des Schwefels in flüssigen organischen Substanzen. *Chem.-Zeit.*, bd. xvii, pp. 99, 130. [1893.]
3426. — Die Bestimmung des Paraffins in Braunkohlentheer. *Ibid.*, pp. 1410, 1411. [1893.]
3427. — Ueber Paraffinbestimmungen. *Ibid.*, pp. 1473, 1483, 1484. [1893.]
3428. — Ueber Paraffin und Paraffinkerzen. *Zeitschr. angew. Chem.*, bd. xvi, pp. 613, 614. [1903.]
3429. **Hörler, H.** Zur Untersuchung und Behandlung des Petroleumums. *Polyt. Journ.*, bd. cccxvii, pp. 52-61. [1879.]
3430. **Hörnecke, —** Das Petroleum in den Vereinigten Staaten Nord Amerikas. *Zeitschr. Paraff. Industr.*, 1877, nos. 7, 21.
3431. **Hoff, B.** Kumburg's neue Erdölampe und B. Hoff's Multiplikator. *Polyt. Journ.*, bd. ccl, pp. 409-413. [1883.]
3432. **Hoffmann, B.** Einige Notizen über Ozokerit. *Polyt. Centralbl.*, bd. xxxiii, p. 288. [1867.]
3433. **Hoffmann, C.** Bericht über die im Sommer d. J. 1878 im östlichen Teile des Szilagyer Comitates durchgeführten geologischen Aufnahmen. *Földt. Közl.*, köt. ix, pp. 231-283. [1879.]
3434. **Hoffmann, E.** Infundir-Apparate mit constantem Niveau und Petroleum-heizung. *Arch. Pharm.*, bd. ccxliii, pp. 48-54. [1878.]
3435. — Die Oelfelder von Tschatma, Takla und Eldar. *Petroleum Zeitschr.*, bd. vi, pp. 9-15. [1910.]
- Hoffmann, F.**, see **Gildemeister, E.**
3436. **Hoffmann, F. A.** Asphalt-Vorkommen von Limmer bei Hannover und von Vorwohle am Hils. *Zeitschr. prakt. Geol.*, bd. liii, pp. 370-379. [1895.]
3437. — Asphalt-Kalk. *Ibid.*, bd. v, pp. 67, 68. [1897.]
3438. **Hoffmann, G. C.** Chemical Contributions to the Geology of Canada, from the Laboratory of the Survey. *Rep. Geol. Surv. Canada*, 1880-1882. [1883.]
3439. — Annotated List of the Minerals occurring in Canada. *Ann. Rep. Geol. Surv. Canada*, n.s., vol. iv, T. [1890.]
3440. — Report of the Section of Chemistry and Mineralogy [for 1894]. *Ibid.*, vol. vii, R. [1896.]
3441. **Hoffmann, J. F.** Chemische Gleichung der Bildung fossiler Brennstoffe. *Beitr. Geophys.*, bd. vii, pp. 327-378. [1905.]
3442. **Hoffmeister, A.** Methode zur Prüfung des Verhaltens der Schmieröle bei niederen Wärmegraden. *Mith. k. techn. Versuchsanst.*, bd. vii, pp. 24-27. [1889.]
- Hofmann, A. W.**, see **Buff, H.**
3443. **Hofmann, C.** (Ed.). Kesselreinigung mit Petroleum. *Papier-Zeit.*, bd. xviii, pp. 2916, 2984. [1893.]
3444. **Hofstädter, P. G.** Ueber künstliches und mineralisches Paraffin. *Sitz. k. Ak. Wiss. Wien*, bd. xliii, pp. 436-443. [1854.]
3445. **Hogendorp, W. v.** Beschrijving van het eiland Timor. *Verh. Bat. Genootsch.*, dl. I, pp. 192-214; dl. II, pp. 405-431. [1781, 1784.]
3446. **Hohescu, C.** [Productivity of Wells]. *Monit. Int. Pétr. Roum.*, t. vi, pp. 814-816. [1905.]
3447. — [Systematic Working of Petroleum]. *Ibid.*, t. vii, pp. 121-125. [1906.]
3448. — Les Eaux Souterraines dans les Régions Pétrolifères. *Compt. Rend. Congr. internat. Pétr.*, sess. 3, t. II, pp. 205-228. [1910.]
3449. — Monopole d'état de la Vente du Lampant en Roumanie. *Ibid.*, pp. 911-913. [1910.]
3450. **Holdo, D.** Qualitativer Nachweis von Harzöl in vegetabilischen und mineralischen Oelen. *Mith. k. techn. Versuchsanst.*, bd. vi, p. 88. [1888.]
3451. — Die Flammprüfungen von Mineral schmierölen. *Ibid.*, bd. vii, pp. 64-72. [1889.]
3452. — Nachweis von Mineralöl in fetten Oelen. *Ibid.*, p. 75. [1889.]
3453. **Holdo, D.** Vergleichende Prüfung der Methoden zur Bestimmung des Säuregehaltes von Oelen. *Mith. k. techn. Versuchsanst.*, bd. vii, pp. 116-119. [1889.]
3454. — Flammpunktsbestimmung von Schmierölen. *Ibid.*, pp. 153-156. [1889.]
3455. — Eine vereinfachte Vorrichtung zur massanalytischen Bestimmung des Säuregehaltes in Oelen. *Ibid.*, bd. viii, pp. 161-183. [1890.]
3456. — Ueber ein kautschuckhaltiges Mineralöl. *Ibid.*, pp. 308-310. [1890.]
3457. — Zur Prüfung von Mineralölen und fetten Oelen auf Harzöle. *Ibid.*, bd. ix, pp. 51, 52. [1891.]
3458. — Zur Prüfung der Kältebeständigkeit von schwarzen Mineral schmierölen. *Ibid.*, bd. x, pp. 126-130. [1892.]
3459. — Fortschritte auf dem Gebiete der Fette, Oele, Seifen, und Naphta-Industrie. *Chem.-Zeit.*, bd. xvi, pp. 1049-1056. [1892.]
3460. — Die Ausdehnungskoeffizienten der schweren Destillationsprodukte und Residuen des Rohpetroleumums. *Mith. k. techn. Versuchsanst.*, bd. xi, pp. 45-68. [1893.]
3461. — Ueber die Löslichkeit dunkler Mineral schmieröle in Petroleum-benzin. *Ibid.*, pp. 261-272. [1893.]
3462. — Der Harzgehalt und die Verharzungsfähigkeit der Mineral schmieröle. *Ibid.*, bd. xiii, pp. 174-196. [1895.]
3463. — Unterscheidung von Petroleum-benzin und Steinkohlenbenzin. *Ibid.*, pp. 241-244. [1895.]
3464. — Neuere Erfahrungen in der Schmierölprüfung. *Ibid.*, pp. 253-287. [1895.]
3465. — Bericht über vergleichende Schmieröluntersuchungen, ausgeführt in den Jahren 1889-1894. *Ibid.*, Ergänzungsheft, no. 1. [1895.]
3466. — Jahresberichte der chemischen Industrie. Fortschritte auf dem Gebiete der Fette und Naphta-Produkte. *Chem.-Zeit.*, bd. dix, pp. 573-578; bd. xx, pp. 907-912. [1895, 1896.]
3467. — Veränderungen des Erstarrungsvermögens von Mineralölen. *Mith. k. techn. Versuchsanst.*, bd. xiv, pp. 113-116. [1896.]
3468. — Die quantitative Bestimmung des Paraffins in den hochsiedenden Destillationsprodukten des Rohpetroleumums. *Ibid.*, pp. 211-221. [1896.]
3469. — Vorschläge zur Herbeiführung einheitlicher Prüfungsverfahren bei Mineral schmierölen. *Chem. Rev. Fett-Harz-Ind.*, bd. iii, pp. 1-5, 17-22. [1896.]
3470. — Die Untersuchungen der Schmiermittel und verwandter Produkte der Fett- und Naphta-Industrie. *Svo, Berlin*, 1897. (Ed. II. D. unters. d. Mineralöle und Fette, 1906.)
3471. — Die Paraffinbestimmung in hochsiedenden Destillaten des Braunkohlentheers und des Rohpetroleumums. *Zeitschr. angew. Chem.*, bd. x, pp. 116, 117. [1897.]
3472. — Zur Theorie der Erdölbildung. *Ibid.*, pp. 623, 624. [1897.]
3473. — Die quantitative Bestimmung des Paraffins in den hochsiedenden Destillationsprodukten des Rohpetroleumums. *Chem. Rev. Fett-Harz-Ind.*, bd. iv, pp. 4-6, 21-25. [1897.]
3474. — Die Berücksichtigung der Ausdehnung der Oele bei der Flammpunktsbestimmung von hochsiedenden Mineralölen. *Ibid.*, pp. 51, 52. [1897.]
3475. — Die quantitative Bestimmung des Paraffins in den hochsiedenden Destillaten des Rohpetroleumums. *Ibid.*, pp. 148-151. [1897.]
3476. — Ueber Werthbestimmung der Schmiermittel. Erstattung von Vorschlägen über einheitliche Untersuchungs-methoden und über eine einheitliche Nomenclatur in der Erdölindustrie, sowie über Werthbestimmung von Schmierölen. *Compt. Rend. Congr. internat. Chem. Appl.*, sess. 3, t. III, pp. 32-35. [1899.]
3477. — Die neuen Anleitungen zur Untersuchung der Mineralöle und des Ceresins für die zollamtliche Abfertigung. *Mith. k. techn. Versuchsanst.*, bd. xvii, pp. 35-43, 103-108. [1899.]

3478. **Holde, D.** Die bei der Destillation der flüssigen Bitumina und der Fettstoffe erhaltenen Fehrrückstände. *Chem. Rev. Fett-Harz-Ind.*, bd. vii, pp. 2-8. [1900.]
3479. — Die Petroleumindustrie auf der Pariser Ausstellung. *Zeitschr. angew. Chem.*, bd. xiii, pp. 1200-1208. [1900.]
3480. — Die Prüfung der Pensky'scher Flammprüfprifer. *Ibid.*, bd. xiv, p. 474. [1901.]
3481. — Qualitativer Nachweis von Mineralöl in Harzöl. *Mitth. k. techn. Versuchsanst.*, bd. xix, pp. 39-44. [1901.]
3482. — Chemie und Technik des Erdöls und verwandter Mineralöle. *Chem. Zeitschr.*, bd. i, pp. 57-60, 83-85, 120-122, 283-285, 308-311, 341, 342, 606-608, 627-629; bd. ii, pp. 148-151, 341-343, 369, 370, 536-538, 608, 609; bd. iii, pp. 233-237. [1901-1904.]
3483. — Die Bestimmung der Verdampfbarkheit schwerer Mineralöle. *Mitth. k. techn. Versuchsanst.*, bd. xx, pp. 67-70. [1902.]
3484. — Ueber Untersuchung von Paraffinkerzen. *Ibid.*, pp. 241-251. [1902.]
3485. — Verschiedene Mittheilungen aus der Abtheilung für Oelprüfung. *Ibid.*, pp. 252-254. [1902.]
3486. — Unterscheidung der zollpflichtigen Heissdampf-cylinderöle von Rohölen und zollfreien Rückständen. *Compt. Rend. Congr. internat. Chem. Appl.*, sess. 5, t. ii, pp. 496-498. [1904.]
3487. — Unterscheidung zollpflichtiger und zollfreier pechartiger Erdölrückstände. *Ibid.*, pp. 498-501. [1904.]
3488. — Ueber verharzte Produkte in Mineralölen. *Zeitschr. angew. Chem.*, bd. xx, pp. 1263, 1223. [1907.]
3489. — Ueber den physikalischen Zustand von Maschinenfetten, öligen Kalkseifenlösungen und schweren Mineralölen. *Ibid.*, bd. xxi, pp. 2138-2144. [1908.]
3490. — Ueber einen elektrisch geheizten Pensky'schen Flammprüfprifer. *Chem.-Zeit.*, bd. xxii, p. 650. [1908.]
3491. — Erfahrungen mit Normalbenzin und Asphaltbestimmungen in dunklen Mineralölen. *Mitth. k. Mat.-Prüf.-Amt.*, bd. xxvii, pp. 143-148. [1909.]
3492. — Ueber Zusammensetzung, Abscheidung, und Entstehung der hochsiedenden, insbesondere der verharzten Stoffe in Erdölen und Naturasphalten. *Compt. Rend. Congr. internat. Pétrole*, sess. 3, t. ii, pp. 705-718. [1910.]
3493. — Ueber Petroleum und Erdwachsindustrie im Rumänien und Galizien. *Zeitschr. angew. Chem.*, bd. xxiii, pp. 163, 164. [1910.]
3494. **Holde, D.**, and **L. Allen.** Die Quantitative Bestimmung des Paraffins in Destillaten des Rohpetroleums und des Braunkohlentheers. *Mitth. k. techn. Versuchsanst.*, bd. xvi, pp. 97-113. [1898.]
3495. **Holde, D.**, and **R. Eickmann.** Ueber verharzte Produkte in Mineralölen. *Ibid.*, bd. xxv, pp. 145-154. [1907.]
3496. **Holde, D.**, and **J. Marcusson.** Die Unterscheidung und chemische Natur von dunklen, pechartigen Rückständen der Destillation von Erdölen, Fetten und Fettsäuren. *Ibid.*, bd. xviii, pp. 147-157. [1900.]
3497. **Holde, D.**, and **K. Schäfer.** Zur Untersuchung von Asphaltpulvern auf Bitumengehalt. *Ibid.*, bd. xxiv, pp. 109-114. [1906.]
3498. **Holde, D.**, and — **Schwarz.** Ueber Untersuchung von Paraffin-Kerzen. *Ibid.*, bd. xx, pp. 241-251. [1902.]
3499. **Holde, D.**, and **M. Stange.** Die Zähigkeitsbestimmung von Erdölrückständen auf dem Engler'schen Apparat. *Ibid.*, bd. xviii, pp. 157-160. [1900.]
3500. **Holde, D.**, **L. Ubbelohde**, **L. Weinstein**, **R. Zulozcki**, and **L. Edeleanu.** Principes Fondamentales pour l'Examen des Huiles Minérales. *Compt. Rend. Congr. internat. Pétrole*, sess. 3, t. ii, pp. 792-804. [1910.]
- Holde, D.**, see **Guiselin, A.**, and **Martens, A.**
3501. **Hoilen, H. C. L.** The Road-Motors of the Present Day, and some Unsolved Problems connected with them. *Proc. Inst. Civ. Eng.*, vol. clxxvii, pp. 136-163. [1909.]
3502. **Holland, H.** Travels in the Ionian Isles, Albania, Thessaly, Macedonia, etc., 1812, 1813. Map and Plates. 2 vols. 8vo, London, 1819.
3503. **Holland, T. H.** On Mineral Oil from the Suleiman Hills. *Rec. Geol. Surv. Ind.*, vol. xxiv, pp. 84-97; vol. xxv, pp. 175-180. [1892.]
3504. — General Report on the work carried on by the Geological Survey of India for the year 1902-1903. 8vo, Calcutta, 1903.
3505. — Review of the Mineral Production of India during the years 1898-1903. *Rec. Geol. Surv. India*, vol. xxxii, pp. 1-118, pls. 1-6. [1905.]
3506. — The Mineral Production of India during 1904 [-1905]. *Ibid.*, vol. xxxiii, pp. 1-32; vol. xxxvi, pp. 63-108; vol. xxxvii, pp. 57-128; vol. xxxviii, pp. 71-125. [1906-1909.]
3507. — Quinquennial Review of the Mineral Production of India during the years 1904-1908. *Ibid.*, vol. xxxix, pp. 1-280, pls. 1-viii. [1910.]
3508. — Sketch of the Mineral Resources of India. 3 pls. 4to, Calcutta, 1908.
3509. — General Report of the Geological Survey of India for the years 1907, 1908. *Rec. Geol. Surv. Ind.*, vol. xxxvii, pp. 1-56; vol. xxxviii, pp. 1-70. [1908, 1909.]
3510. — The Trend of Mineral Development in India. *Journ. Soc. Arts*, vol. lix, pp. 626-655. [1911.]
3511. **Holley, A. L.** On the Use of Natural Gas for Puddling and Heating at Leechburg, Pennsylvania. *Trans. Amer. Inst. Min. Eng.*, vol. iv, pp. 32-34. [1876.]
- Hollis, G. F.**, see **Anderson, A. A.**
3512. **Hoobek, J.** Der Erdwachsbergbau in Galizien und die neuen Bergpolize; Vorschriften für denselben. Vienna, 1900.
3513. — Die geologischen Verhältnisse der Erdwachs- und Erdöllagerstätten in Boryslaw. Führer für Exkursionen ix Internat. Geol. Kongr. Vienna, 1903.
3514. — Die Erdwachs- und Erdöllagerstätten in Boryslaw. *Compt. Rend. Congr. Geol. internat.*, sess. ix, pp. 777-786. [1904.]
3515. — Die Schlagwetterexplosion in dem Erdwachsbergbau "Gruppe I." in Boryslaw am 2 Juni 1902. *Oesterr. Zeitschr. Berg. Hüt.*, bd. lii, pp. 42-45, 55-59, pl. ii. [1904.]
3516. **Hoiten, J. v.** [Sources of Petroleum in Bolivia.] *Act. Soc. Sci. Chile*, t. liii, proc.-verb., p. lvii. [1893.]
3517. **Hopberg,** — [Effect of Pressure on Petroleum.] *Nephth, Dielo*, 1909, no. 24.
3518. **Hombres-Firmas, L. A. d'.** Notice sur l'asphalte et les pétrifications d'Auzon, département du Gard, pour servir à l'histoire naturelle de ce pays. *Bibl. Univ.*, t. ix, pp. 236-240. [1818.]
3519. **Homère, A.** La Crise pétrolière russe (Maïkop contre Grosny) *Journ. Pétrole*, t. x, pp. 177-181. [1910.]
3520. — Note sur le gisement pétrolière de Grozni. *Ibid.*, t. xi, pp. 178-180. [1911.]
3521. — Note sur la région de la presqu'île de Taman. *Ibid.*, pp. 184, 185. [1911.]
3522. **Honeyman, D.** Note on limestone containing petroleum in Nova Scotia. *Amer. Journ.*, ser. 3, vol. i, p. 386. [1871.]
3523. — Note on the Identification of the Scotch and New Brunswick Albertites. *Min. Mag.*, vol. vii, pp. 77, 78. [1886.]
3524. **Hoover, T. J.** Recent Progress at Maïkop. *Mining Mag.*, May 5, 1911.
3525. **Hooze, J. A.** Nadere gegevens betreffende enkele kolentereinen in Koetjen onderzoek eener Aardoliebron aldaar. *Jaarb. Mijnw. Ned. O. Ind.* jg. xvii, Techn. pp. 325-336, 2 maps. [1888.]
3526. **Hope, L.** The Application of the Internal Combustion Engine to Fishing and Commercial Vessels. *Trans. Inst. Naval Arch.*, vol. lii, pp. 120-139. [1910.]

3527. **Hopkins, E.** The Oil-Chemists' Handbook 8vo, New York, 1900.
3528. **Hopkins, F. V.** First Annual Report of the Louisiana State Geological Survey. *Ann. Rep. La. Milit. Acad.*, for 1869, pp. 77-109. [1870.]
3529. **Hopkinson, B.** Internal Combustion Engines. *Gas and Oil Eng. Rec.*, vol. ii, pp. 251, 252. [1906.]
3530. ——— The Effect of Size and Speed upon the Performance of an Internal Combustion Engine. *Proc. Inst. Automob. Eng.*, n.s., vol. iii, pp. 211-273. [1909.]
3531. **Hopkinson, B.**, and **L. G. E. Morse.** On the Gases Exhausted from a Petrol Motor. *Engineering*, vol. lxxxiv, pp. 197, 219-221. [1907.]
3532. **Hoppe-Seyler, F.** Erregung des Sauerstoffs durch nascerenden Wasserstoff. *Ber. deutsch. chem. Ges.*, bd. xii, pp. 1551-1555. [1879.]
3533. ——— Ueber Gährung der Cellulose, mit Bildung von Methan und Kohlensäure. *Zeitschr. physiol. Chem.*, bd. x, pp. 201-217, 401-440. [1886.]
3534. **Hopper, W. E.** The Caddo Oil and Gas-Field, Louisiana. *Bull. Amer. Inst. Mining Eng.*, vol. xxii, pp. 283-309. [1911.]
3535. **Hopper, W. E.**, see **Harris, E.**
3536. **Hopps, J. H.** Marine Use of Fuel Oil. *Journ. Amer. Soc. Mech. Eng.*, vol. xxxiii, pp. 896-903. [1911.]
3536. **Horn, F. M.** Quantitative Bestimmung von Paraffin, Ceresin, Mineralölen in den Fetten und in den Wachsen. *Zeitschr. angew. Chem.*, bd. i, pp. 458-460. [1888.]
3537. **Hornaday, W. D.** Petroleum in Mexico. *Min. Eng. World*, 1911.
3538. **Hornung, F.** Ueber Petroleumbildung. *Zeitschr. deutsch. geol. Ges.*, bd. lvii, Br. M., pp. 534-556. [1906.]
3539. ——— Das Erdöl von Helfta bei Eisleben. *Monatsb. deutsch. geol. Ges.*, 1907, pp. 115-122.
3540. **Horsfield, T.** Essay upon the Geography, Mineralogy, and Botany of the Western Portion of the Territory of the Native Princes of Java. *Verh. Batav. Genoots.*, dl. viii, pp. 175-312. [1816.]
3541. **Horvath, E.** [Petroleum and Asphalt of Hungary.] *Ban. Koh. Lap.*, cvf. xl, köt. 1, pp. 695-698. [1907.]
3542. **Hose, C.** A Journey up the Baram River to Mount Duilt and the Highlands of Borneo. *Geogr. Journ.*, vol. i, pp. 193-208, map. [1893.]
3543. **Hosie, A.** Report on the Province of Ssueh'uan, China, no. 5. *Fo., London*, 1904.
3544. **Hoskold, R. D.** Notes upon the Mines in the Argentine Republic, South America. *Trans. N. Engl. Inst. Eng.*, vol. xii, pp. 126-154, 235, 234. [1892.]
3545. **Hossfeld, F. W.** Ozocerite, or Mineral Wax, in Austria. *Rep. Cons. U.S.*, vol. lxvi, pp. 504-508. [1901.]
3546. **Hosty, R. C.** The Oil Fields of Tayabas. *Philippine Resources*, Nov. 1909, p. 2.
3547. **Hotz, W.** Die Lagerstätten nutzbarer Mineralien in der Schweiz. *Zeitschr. prakt. Geol.*, bd. xvii, pp. 29-42, pl. 1. [1909.]
3548. **Hough, B. O.** Discovery of Petroleum [Historical]. *Amer. Exporter*, vol. lxxv. Feb. 1910.
3549. **Hough, E. S.**, and **W. H. Crawford.** Report of recent Oil-burning Installations on the Pacific Coast. *Marine Engineering*, vol. vii, pp. 447-451. [1902.]
3550. **Houthumb, C. A.** Aus den Oelregionen Pennsylvaniens. *Fels zum Meer*, July 1886.
3551. **Hovel, —.** Ueber ein Steinölvorkommen in den Steinkohlenwerke bei Wettin. *Abh. Nat. Ges. Halle*, 1863, p. 14.
3552. **Hovey, E. O.** Asphaltum and Bituminous Rock. *Min. Res. U.S.* 1903-1905. [1905, 1906.]
3553. **How, H.** On an Oil-coal near Picton, Nova Scotia, and the comparative composition of the Minerals often included in the term Coals. *Amer. Journ.*, ser. 2, vol. xxx, pp. 74-79. [1860.]
3554. **Howard, J. L.** Fuel Conditions in California [Pacific Oil Gas Assoc.]. *Amer. Gas Light Journ.*, bd. lxxvii, pp. 256-258. [1902.]
3555. **Howari, J. W.** Asphaltum. *Min. Ind.*, vol. ii, pp. 43-52; vol. iv, pp. 43-46. [1894, 1896.]
3556. **Howell, E. J.** Mexico: its progress and commercial resources. 8vo, London, 1892.
3557. **Howell, G.** Geology of Chatma [Tchatma, Tifis]; Continuance of the Oligocene and Miocene Beds of Baku. *Petrol. World*, vol. viii, p. 492. [1911.]
3558. **Howell, H. H.**, and **A. Geikie.** The Geology of the Neighbourhood of Edinburgh (map 32). *Mem. Geol. Surv. Gr. Br., London*, 1861.
3559. **Howles, F.**, see **Farrel, F. J.**
3559. **Hoyer, —.** Petroleum in Deutschland und das Vorkommen in Wietze. *Journ. Gasbeleucht.*, bd. xlvii, pp. 762-768. [1904.]
3560. **Hubbard, C. L.** Liquid Fuel. *Power*, vol. xxix, pp. 400, 401. [1908.]
3561. **Hubbard, L. L.** The Origin of Salt, Gypsum and Petroleum. *Geol. Surv. Michigan*, vol. v, pp. ix-xxiv. [1895.]
3562. **Hubbard, L. L.**, see **Wright, C. E.**
3562. **Hubbard, P.** Dust Preventives. *U.S. Office of Public Roads*, Bull. no. 34. [1908.]
3563. ——— The Effect of Free Carbon in Tars from the Standpoint of Road Treatment. *Proc. Amer. Soc. Test. Mat.*, vol. ix, pp. 549-567. [1909.]
3564. ——— Dust Prevention. 8vo, New York, 1909.
3565. ——— The Examination of Bituminous Road Binders. *Compt. Rend. Congr. internat. Chim. Appl.*, sess. 7, sect. II, pp. 245-261. [1910.]
3566. ——— Bitumens and their Essential Constituents for Road Construction and Maintenance. *U.S. Office of Public Roads*, Circ. 93, p. 16. [1911.]
3567. **Hubbard, P.**, and **C. S. Reeve.** The Determination of Soluble Bitumen. *Proc. Amer. Soc. Test. Mat.*, vol. x, pp. 420-443. [1910.]
3568. ——— Methods for the Examination of Bituminous Road Materials. *U.S. Dept. Agric. Office of Public Roads*, Bull. no. 38. Pp. 45. [1911.]
3569. **Huc, —.** Souvenirs d'un voyage dans la Tartarie, le Thibet et la Chine, pendant 1844-46. 2 Tt. 8vo, Paris, 1850.
3570. ——— L'Empire Chinois, faisant suite à l'ouvrage intitulé "Souvenirs d'un Voyage dans la Tartarie et le Thibet." 2 Tt. 8vo, Paris, 1853, 1854.
3571. **Hudleston, W. H.** On the Geology of Palestine. *Proc. Geol. Assoc.*, vol. viii, pp. 1-53, pls. i, ii. [1883.]
3572. **Hudson, E. J.**, see **Mabery, C. F.**
3572. **Hue, F.** Le Pétrole, son Histoire, ses Origines, son exploitation dans tous les pays du Monde. 18mo, Paris, 1885.
3573. ——— [Petroleum in America.] *Gorn. Journ.*, 1888, t. 2, pp. 100-160.
3574. **Hübner, B.** Ueber die fabrikmässige Darstellung von Photogen, Solaröl und Paraffin aus Braunkohlen. *Polyt. Journ.*, bd. cii, pp. 119-125. [1859.]
3575. ——— Vorläufige Mittheilung über Paraffin-Fabrication aus Braunkohlentheer. *Ber. deutsch. chem. Ges.*, bd. i, pp. 133-135. [1868.]
3576. ——— Antrag auf Abänderung der untern 24 Sept. 1868 adoptirten Methode zur Ermittlung des Schmelz-, resp. Erstarrungspunktes von Paraffin. *Journ. Gasbeleucht.*, bd. xiv, pp. 688, 689. [1871.]
3577. **Hübner, B.**, and **R. Voerkel.** Ueber den Gehalt einiger Kohlenarten an leichten Oelen, schweren Oelen, Paraffinmasse, etc. *Polyt. Journ.*, bd. cxliii, pp. 143-149. [1857.]
3578. **Hughes, G.** Natural History of the Island of Barbadoes. London, 1750.
3579. **Hughes, H. H.**, and **H. Hale.** Crude Petroleum as a Reducing Agent for Zinc Ores. *Journ. Ind. Eng. Chem.*, vol. i, pp. 788, 789. [1909.]
3580. **Hughes, S.**, see **Frankland, E.**
3580. **Hughes, T. W. H.** Petroleum in Assam. *Rec. Geol. Surv. India*, vol. vii, pp. 55-58. [1874.]
3581. **Hughes-Lafetra, —.** Report on the Trade and Commerce of Port Said and Suez for 1902. *Dipl. Cons. Rep.*, ann. ser., no. 3051. [1903.]



3582. **Huguenet, I.** Asphaltes et Naphtes. Considérations générales sur l'origine et la formation des bitumes fossiles et de emploi, etc. *Paris* 1847.
3583. **Humbert, —**. Note sur des Dégagements de gas inflammables survenus dans le Glaisières de Vanves et de Malakoff (Seine). *Ann. Mines*, sér. 9, t. viii, Mém. pp. 14-26. [1895.]
3584. **Humboldt, A.** Fuel. *London*, 1897.
3585. **Humboldt, F. H. A. v.** Geognostische Skizze von Südamerika. *Ann. Phys.*, bd. xvi, pp. 394-449. [1804.]
3586. — Vues des Cordilleres et Monumens des peuples indigènes de l'Amérique. *Paris*, 1810.
3587. — Asie Centrale. Recherches sur les chaînes de montagnes et la climatologie comparée. 3 Tt. 8vo, *Paris*, 1843.
3588. — Dampf- und Gas-quellen, Salsen, Schlamm-Vulkane, Naphta, Feuer. *Kosmos*, bd. i, pp. 232-234; bd. iv, pp. 216, 253. [1844, 1849.]
3589. **Humboldt, F. H. A. v.**, and **A. Bonpland.** Voyage aux Régions Equinoxiales du Nouveau Continent, fait en 1799, 1800, 1801, 1802, 1803 et 1804. 7 Tt. 4to, *Paris*, 1810-1814.
3590. **Hume, G.** Oil Fuel on Shipboard. *Trans. Inst. Marine Eng.*, vol. xix, no. 137, p. 46, pl. 1907.
3591. **Hume, W. F.** Baku and its Oil Industry. *Nature*, vol. liv, pp. 232-234. [1896.]
3592. — Petroleum: its Occurrence and Origin. *Cairo Sci. Journ.*, vol. iv, no. 48. P. 14. [1910.]
- Hume, W. F.**, see **Barron, I.**
3593. **Humphrey, C.** Dissolution du caoutchouc par le pétrole. *Technol.* t. xxvi, pp. 126, 127. [1864.]
3594. — Vulcanisation du caoutchouc avec emploi du pétrole. *Ibid.*, p. 312. [1864.]
3595. **Humphreys, A. C.**, and **A. G. Glasgow.** Carburetted Water-Gas and Carbon Monoxide. 8vo, *London*, 1890.
3596. **Hunäus, —**. Beiträge zur Kenntniss der landwirthschaftlichen Verhältnisse im Königreich Hannover.
3597. **Hunfaloy, J.** Ausflug in der Marmaros. *Jahrb. ung. Karp. Ver.*, bd. ii. [1875.]
3598. **Hunt, —**. Report on the Trade of Kertch for 1886. *Dipl. Cons. Rep.*, ann. ser., no. 115, pp. 13-16. [1887.]
3599. **Hunt, A. M.** California Petroleum and its Use as Fuel. *Journ. Electr.*, May 1903.
3600. — Atomization of Oil. *Trans. Amer. Soc. Mech. Eng.*, vol. xxxiii, pp. 883-886. [1911.]
3601. **Hunt, H. T. C.** Reports for 1887-1892 on the Trade of Königsberg and Dantzig. *Dipl. Cons. Rep.*, ann. ser., nos. 422, 808, 1299, 1636, 1805, 2000. [1888-1893.]
3602. **Hunt, H. W.** Report for the years 1895, 1896 on Taganrog. *Ibid.*, nos. 1736, 1948. [1896, 1897.]
- Hunt, S. P.**, see **Gill, A. H.**
3603. **Hunt, T. S.** Notes on the History of Petroleum or Rock Oil. *Canad. Nat.*, vol. vi, pp. 241-255. [1861.]
3604. — Contributions to the Chemical and Geological History of Bitumens and of Pyroschists or Bituminous Shales. *Amer. Journ.*, ser. 2, vol. xxxv, pp. 157-171. [1863.]
3605. — Petroleum, its geological relations considered with special reference to its occurrence in Gaspe. *Quebec*, 1865.
3606. — [Geology of Petroleum.] *Rep. Geol. Surv. Canada*, 1863-1866, pp. 232-262. [1866.]
3607. — On Petroleum. *Proc. Amer. Assoc.*, vol. xv, pp. 29, 30. [1866.]
3608. — Sur les pétroles de l'Amérique du Nord. *Bull. Soc. Géol. France*, sér. 2, t. xxiv, pp. 570-573. [1867.]
3609. — The Oil-bearing Limestone of Chicago. *Proc. Amer. Assoc.*, vol. xix, pp. 157-159. [1870.]
3610. — On the Oil Wells of Terre Haute, Indiana. *Amer. Nat.*, vol. v, pp. 576, 577. [1871.]
3611. — Chemical and Geological Essays. *Boston*, 1875.
3612. **Hunter, C. M.** Raising Oil by Pumping. *Compt. Rend. Congr. internat. Pétrole*, sess. 3, t. ii, pp. 445-452. [1910.]
3613. **Hunter, W.** Concise Account of the Kingdom of Pegu, its Climate, Produce, Trade, Government and Inhabitants. . . . 8vo, *London*, 1784.
3614. **Hunter, W. W.** Statistical Account of Assam, 1879.
3615. **Huntly, G. N.** The Accuracy Obtainable in Fuel Calorimetry. *Chem. Eng.*, vol. xiii, pp. 147-152 [1911.]
3616. **Huo, J. J. N.** [Geology of Wallachia and Moldavia.] *Bull. Soc. Géol. France*, t. x, pp. 153-155. [1838.]
3617. **Hurmuzescu, A.** Die Radioaktivität der Erdöle von Rumänien. *Zeitschr. angew. Chem.*, bd. xxiv, pp. 26, 27. [1911.]
3618. — Die Radioaktivität des Petroleum. *Petroleum Zeitschr.*, bd. iii, pp. 235, 236. [1907.]
3619. — La Radioactivité des Pétroles de Roumanie. *Ann. Sci. Univ. Jassy*, t. v, pp. 1-31. [1903.]
3620. — Sur la Radioactivité du Pétrole. *Compt. Rend. Congr. internat. Pétrole*, sess. 3, t. ii, pp. 771-774. [1910.]
3621. **Hurst, G. H.** Lubricating Oils, Fats, and Greases; Their Origin, Preparation, Properties, and Analyses. 8vo, *London*, 1896.
3622. — Soaps. A Practical Manual of the Manufacture of Domestic Toilet, and other Soaps. 8vo, *London*, 1898.
- Husson, A. H.**, see **Figari, A.**
3623. **Hutchison, L. L.** Mid-Continent Oil and Gas Fields. *Min. Sci. Press*, vol. c, pp. 100, 101. [1910.]
3624. — Preliminary Report on the Rock-Asphalt, Asphaltite, Petroleum, and Natural Gas in Oklahoma. *Bull. Oklahoma Geol. Survey*, no. 2. [1911.]
3625. — The Origin of Oil and Gas; Theories of the Nature and Causes of Accumulation. *Petrol. Rev.*, vol. xxiv, pp. 303, 304, 335. [1911.]
- Hutchison, L. L.**, see **Gould, C. N.**
3626. **Huth, P.** Die Mineralöquellen bei Wietze. *Chem. Rev. Fett-Harz-Ind.*, bd. viii, pp. 185, 186. [1901.]
- Hutton, R. S.**, see **Pring, J. N.**
3627. **Hutton, T.** Notes on the Geology and Mineralogy of Afghanistan. *Calcutta Journ. Nat. Hist.*, vol. vi, pp. 564-611. [1846.]
3628. **Hutton, W. R.** On the Igniting Point of the Vapours of some Commercial Products. *Proc. Phil. Soc. Glasgow*, vol. xix, pp. 49-53. [1869.]
3629. **Huxley, T. H.** On the Formation of Coal. *Contemp. Rev.*, vol. xv, pp. 618-629. [1870.]
3630. **Hviid, N. Ch.** Die katalytischen und kapillar-chemischen Vorgänge bei der Erdölbildung. *Petroleum Zeitschr.*, bd. vi, pp. 429-436. [1911.]
3631. **Hviid, N.**, and **E. Severin.** Eine Modifikation der üblichen Methode für die Aschenbestimmung von Mineralölen. *Petroleum Zeitschr.*, bd. v, pp. 1454-1456. [1910.]
3632. **Hyde, N. J.** Report of the State Supervisor of Oils for 1891-1894. *Ann. Rep. Geol. Indiana*, vol. xvii, pp. 301-305; vol. xviii, pp. 190-195; vol. xix, pp. 112-122; vol. xx, pp. 461-466. [1892-1896.]
3633. **Hyde, T.** Veterum Persarum et Medorum Religionis eorumque Magorum Historia. 4to, *Oxford*, 1700.
3634. **Ienisch, H. Kh.** [Oil Fuel for Steamers on the Caspian Sea.] *Morsk. Sborn.*, 1876, no. 8, pp. 1-29.
3635. — [Action of Oil Fuel on Boilers.] *Zap. Imp. Russk. Tekhn. Obsch.*, g. xii, otd. i, pp. 40-54. [1878.]
3636. **Igelstrom, L. J.** Om mäktiga Lager af bituminös Gneiss och Glimmerskiffer uti Nullaberget, Ostmarks socken i Wermland. *Ofve. K. Vet.-Akad. Förh.*, bdt. xxiii, pp. 211-213. [1866.]
3637. — Mineralogiska Meddelanden. *Geol. Fören. Stockh. Förh.*, bd. viii, pp. 477, 478. [1886.]
3638. **Igelstrom, L. J. A. E. Nordenstiöld**, and **F. L. Ekman.** On the Existence of Rocks containing organic substances in the fundamental gneiss of Sweden. 8vo, *Stockholm*, 1867.

3639. **Hilder, H.** Beiträge zur Chemie des Braunkohlenteers. *Zeitschr. angew. Chem.*, bd. xvii, pp. 523-525, 1670, 1671. [1904.]
3640. **Ihlseng, M. C.** Report on the Oil-fields of Fremont County. *Ann. Rep. Colorado State Sch. Mines*, 1886, pp. 67-80, pl. [1888.]
3641. **Iki, T.** The Geology of the Echigo Oilfield [Jap. Geol. Surv.]. *Petrol. Rev.*, vol. xxiii, pp. 277, 278, 309, 310, 339. [1910.]
3642. **Ilmow, I. P.** [On the Oil Industry in Baku, and oil pipe-lines as a means for conveying petroleum in Russia.] *Zap. Imp. Russk. Tekhn. Obsch.*, g. xix, Trudi, otd. 1, pp. 15-49. [1885.]
3643. ——— [On the rational exploitation of petroleum.] *Ibid.*, pp. 161-168. [1885.]
3644. ——— [Baku Oil and Kerosene.] *Ibid.*, g. xx, Trudi, otd. 1, pp. 345-352. [1886.]
3645. **Imbert, —.** [Letters describing Brine-wells and Natural Gas of Szechuen Province, China.] *Ann. Assoc. Propag. Foi*, t. iii, pp. 309-331. [1828.]
3646. **Immenhöfner, T.** Ueber Heizwerthbestimmungen mit besonderer Berücksichtigung gasförmigen und flüssiger Brennstoffe. 8vo, Berlin, 1905.
3647. **Inchley, W.** Calorific Value of Solid and Liquid Fuels. *Engineer*, vol. cxi, pp. 155, 156. [1911.]
3648. **Ingall, E. D.** Division of Mineral Statistics and Mines; Annual Report for 1889, 1895 to 1905. *Ann. Rep. Geol. Surv. Canada*, d. n. s., vols. iv, viii-xvi (Reports S.). *Ann. Rep. Dept. Mines*, 1904, 1905. [1890-1907.]
3649. **Ingall, E. D.** and **H. P. Brumell.** [The same for 1890 to 1894.] *Ibid.*, vols. v-vii, Reports S. [1893-1896.]
- Ingle, H.**, see **Smithells, A.**
3650. **Iosseliyani, P.** Travels through Kakhetia: Oil wells of Navtluga, Lilo, etc. *Zakavk. Vjestn.*, 1845, nos. 22-28.
3651. **Ipatiew, W. N.** Zur Frage über die Entstehung der Naphtha. *Journ. prakt. Chem.*, bd. ccxii, pp. 800-808. [1911.]
3652. ——— Polymerisation der Aethylen-Kohlenwasserstoffe bei hohen Temperaturen und Drucken. *Ber. deutsch. Chem. Ges.*, bd. xlv, pp. 2978-2987. [1911.]
3653. **Ipatiew, W. N.**, and **N. Dowgolewitsch.** Katalytische Reaktionen bei hohen Temperaturen und Drucken xxii. Zersetzung des Hexans und Hexamethylens; Isomerisation des Hexamethylens. *Ibid.*, pp. 2987-2992. [1911.]
3654. **Ireland, W.** Seventh and Eighth Annual Reports of the State Mineralogist of California, for 1887 and 1888. 8vo, Sacramento, 1888, 1889.
3655. **Irvine, J. E.**, and **W. S. B. Irvine.** The Design of Large Sheet Tanks. *Trans. Glasgow Techn. Coll. Sci. Soc.*, 1910.
3656. **Irvine, R.** Egyptian Petroleum. *Journ. Soc. Chem. Ind.*, vol. vi, pp. 130, 276. [1887.]
- Irvine, W. S. B.**, see **Irvine, J. E.**
3657. **Isaacs, J. D.** A New Method of Pumping Heavy Crude Fuel Oil or other Thick Viscous Fluid. *Eng. News*, vol. lv, pp. 640, 641. [1906.]
3658. **Isbister, A. K.** On the Geology of the Hudson's Bay Territories, and of portions of the Arctic and North-western Regions of America, with a coloured Geological Map. *Quart. Journ. Geol. Soc.*, vol. xi, pp. 497-520, pl. xiv. [1855.]
3659. **Iscu, V.** Technique des couches pétrolières de Monastirea Casin. *Monit. Int. pétrol. Roum.*, t. iv, no. 2. [1903.]
3660. ——— Petroleumzonen in der Ebene. *Compt. Rend. Congr. internat. Pétrole*, sess. 3, t. ii, pp. 331-334. [1910.]
- Iscu, V.**, see **Ciobanu, G. L.**
3661. **Isherwood, B. F.** Report of the Chief of Bureau of Steam Engineering. *Rep. Sec. Navy [U.S.]*, 1867, pp. 171-181.
3662. **Isler, C.** Well-Boring for Water, Brine, and Oil. A Manual of Current Practice. 8vo, London, 1902.
3663. **Issel, A.** Cenno sulla costituzione geologica e su fenomeni geodinamici dell' Isola di Zante. *Boll. R. Com. geol. Ital.*, vol. xxiv, pp. 144-182, pl. v (map 1:200,000). [1893.]
3664. **Isser, M. v.** Die Bitumenschatze von Seefeld. *Berg-Hütt. Jahrb.*, bd. xxvii, pp. 1-31. [1888.]
3665. **Istomin, V. K.** [On the Question of Protective Management of Works in the Baku Oil Industry.] *Trudi Bak. Otd. Imp. Russk. Tekhn. Obsch.*, 1895.
3666. ——— [Oil-fountain Asadulaev no. 3 at Romani, Baku.] *Ibid.*, Feb., pp. 62-70. [1895.]
3667. ——— [Production of Baku Oil-fields.] *Ibid.*, 1896, pp. 557-567.
3668. ——— [Prevention of Oilfield Fires.] *Ibid.*, 1900.
3669. **Istrati, C. I.** Composition chimique du sel gemme de Roumanie. *Bull. Soc. Chim. Paris*, sér. 3, t. ii, pp. 4-8. [1889.]
3670. ——— Le Sel des Salines Roumaines. 8vo, Bucharest, 1904.
3671. ——— [Moldavian Rumanite.] *Bull. Soc. Sci. Bucharest*, t. iv, pp. 59-77; t. vi, pp. 55-59; t. vii, pp. 272, 273. [1895, 1897, 1898.]
3672. ——— [Moldavian Ozokerite.] *Ibid.*, t. vi, pp. 61-93. [1897.]
3673. ——— [Rumanite from the Black Sea.] *Ibid.*, t. ix, pp. 650-652. [1901.]
- Istrati, C. I.**, see **Saligny, A.**
3674. **Itier, J.** Mémoire sur les roches asphaltiques de la chaîne du Jura. *Ac. Soc. Helv. Sci. Nat.*, 1839, p. 157.
3675. **Ivanov, —.** [Geology of Bibi-Eibat Field.] *Trudi Bak. Otd. Russk. Tekhn. Obsch.*, 1903.
3676. **Ivanov, A. O.** [On the motive for the laying down of the pipe-line from Baku to Batum.] *Zap. Imp. Russk. Tekhn. Obsch.*, g. xix, Trudi, otd. 1, pp. 151-161. [1885.]
3677. **Ivanov, A. P.** Sur la Genèse de quelques Argiles des Gisements de Naphte de la Russie méridionale. *Bull. Ac. Imp. Sci. St. Pétersbourg*, sér. 6, 1903, pp. 1009-1014.
3678. ——— [Minerals of Tchetecken Island.] *Ibid.*, 1909, pp. 165-184.
3679. **Ivanov, N.** [Fuels. Memorandum-book for Miners and Engineers.] 1863, pp. 346-393.
3680. **Ivanov, P.** [On Engler's Investigation of the Baku Petroleum.] *Zap. Russk. Tekhn. Obsch.*, g. xxii, v. 1, pp. 89-95; v. 3, pp. 67-80. [1888.]
3681. **Ivens, E. M.** Compressed Air Pumping Systems of Oil-Fields. *Trans. Amer. Soc. Mech. Eng.*, vol. xxxi, pp. 311-332. [1909.]
3682. **Iwan, A.** Ueber die natürlichen und brennbaren Gasausströmungen im Städtgebiete von Wels in Oberösterreich. *Oesterr. Zeitschr. Berg-Hütt.*, bd. xii, Ver. Mitth., pp. 54-56. [1893.]
3683. **Iznar, H. N.** [Russian and Texan Oil Fuel.] *Torg. Prom. Gaz.*, 1902.
3684. **Jaccard, A.** Coupe du Val de Travers, et note sur les divers niveaux de l'asphalte dans le Jura. *Ac. Soc. Helv. Sci. Nat.*, 1868, p. 67.
3685. ——— L'asphalte du Val de Travers. *Rameau de Sapin*, Feb. 1869.
3686. ——— Description géologique du Jura Vaudois et Neuchâtelois et de quelques districts adjacents du Jura Français et de la plaine Suisse compris dans les feuilles vi, xi, et xvi de l'Atlas Fédéral. *Mat. Carte Géol. Suisse*, livr. 6, 7. 1869, 1893.
3687. ——— Sur l'origine de l'Asphalte et des Bitumes. *Verh. Schweiz. Nat. Ges.*, bd. lv, p. 56. [1872.]
3688. ——— Le Pétrole et l'asphalte. Causerie géologique. *Bibl. pop. de la Suisse romande*, 1887.
3689. ——— Sur la présence du bitume et du pétrole dans différents terrains du Jura. *Compt. Rend. Soc. Helv. Sci. Nat.*, sess. 70, pp. 21, 22. [1887.]
3690. ——— Études géologiques sur l'asphalte et le bitume au Val de Travers. *Bull. Soc. Sci. Nat. Neuchâtel*, t. xvii, p. 108, two maps. [1889.]
3691. ——— L'Origine de l'Asphalte, du Bitumen et du Pétrole. *Arch. Sci. Phys. Nat.*, sér. 3, t. xxiii, pp. 501-540; t. xxiv, pp. 106-133, map. [1890.]
3692. ——— Nouvelles notes sur l'Asphalte. *Bull. Soc. Sci. Nat. Neuchâtel*, t. xviii, p. 174. [1890.]

3693. **Jaccard, A.** Emission de gaz inflammable dans le Doubs. *Monde Sci. Nat.*, t. xiv, p. 20. [1891.]
3694. ——— Le Pétrole, l'Asphalte, et de Bitume au point de vue géologique. 8vo, Paris, 1895.
3695. **Jacimski, J.** Untersuchung eines Erdöls aus den Korallenriffen des Roten Meeres. *Freiburg-i-Schweiz.*, 1895.
- Jackson, —**, see **McArthur, —**.
3696. **Jackson, C. T.** [Description, with an Analysis, of Asphaltum recently discovered in New Brunswick.] *Proc. Boston Soc. Nat. Hist.*, vol. iii, pp. 279-282. [1851.]
3697. ——— Report on the Albert Coal Mine, containing an Account of the Situation and Geological Relations of the Rocks, including and accompanying the Coal, . . . comparison with different Varieties of Asphaltum. 8vo, Boston, 1851.
- Jackson, D. D.**, see **Whipple, G. C.**
3698. **Jackson, D. H.**, and **S. Young.** Specific Gravities and Boiling Points of Mixtures of Benzine and Normal Hexane. *Journ. Chem. Soc.*, vol. lxxiii, pp. 922-928. [1898.]
3699. **Jackson, H. D.** Internal Combustion Engines and Hydroelectric Power. Opportunities for Crude Oil Engine. *Power*, vol. xxviii, pp. 987, 988. [1908.]
3700. **Jackson, John R.** Coorongite or Mineral Caoutchouc of South Australia. *Pharmaceut. Journ.*, vol. xxxi, pp. 763, 764, 785. [1872.]
3701. **Jacobi, R.** Mittheilungen über die continuirlichen Destillationsöfen der Photogen- und Paraffin-Fabriken zu Thietzen, Beuel und Washljewskoe. *Polyt. Journ.*, bd. clix, p. 150. [1861.]
3702. ——— Verbesserte Misch- und Waschapparate für Mineralöle. *Ibid.*, bd. cxlii, pp. 257-260; bd. cxliiii, pp. 261-264. [1862, 1863.]
3703. ——— Das americanische Erdöl im Begleich mit dem Braunkohlentheer; Beiträge zur Kenntniss des Werthes und Wesens derselben. *Ibid.*, bd. cxlix, pp. 120-122. [1863.]
3704. ——— Ueber Petroleum und über Explosionem der Petroleumlampen. *Ibid.*, bd. cxv, pp. 379-381. [1870.]
3705. ——— Beiträge zur Geschichte und Statistik der sächsischen Schmelzerei-, Mineralöl-, und Paraffin-Industrie. *Ibid.*, bd. cxviii, pp. 417-421. [1870.]
3706. **Jacobs, E.** Blast Furnace Smelting with Oil. *Eng. Min. Journ.*, vol. xcii, p. 434. [1911.]
- Jacobs, W. A.**, see **Allen, I. C.**
3707. **Jacobsen, E.** Ueber Asphaltlack. *Rep. Ver. chem. Techn.*, 1862, p. 44.
3708. ——— Nachtragliches über Asphaltlack. *Polyt. Notizbl.*, 1864, pp. 168, 169.
3709. **Jacowenko, P.** Beschreibung der Reservoirs mit doppeltem Wasserdruck zur Aufbewahrung von Petroleum und anderer Oelen, als sicherster Schutz gegen Verlust durch Ausstrinnen und Verdampfung sowie gegen Feuersgefahr. *Polyt. Journ.*, bd. cxlix, pp. 275-281. [1866.]
3710. **Jacques, L.** De l'éclairage au gaz. *Rev. Univ. Mines*, t. xxiv, pp. 115-128. [1868.]
3711. **Jacquín, J. v.** Der Zugo bei Klein-Saros in Siebenbürgen, und dessen ewiges Feuer. *Ann. Phys.*, bd. xxxvii, pp. 1-33. [1811.]
3712. **Jacquot, E.**, and **V. Raulin.** Statistique géologique et agronomique du Département des Landes. 8vo, *Mont-de-Marsan & Verdun*. 1874, 1888, 1897.
3713. **Jacunsky, W.** Das Vorkommen und die Gewinnung des Bergöles und Bergwaches zu Borislaw bei Drobobich, in Oest-Galizien. *Oesterr. Zeitschr. Berg-Hüt.*, bd. xlii, pp. 289-295. [1865.]
3714. **Jager, —**. Reise von St. Petersburg in die Krim. [1825.]
3715. **Jahn, H.** Bemerkungen über einige griechische Mineral-Quellen. *Min. petr. Mitth.*, bd. li, pp. 137-176. [1879.]
3716. **Jahn, J. J.** Zur Frage über die Bildung des Erdöls. *Jahrb. k.-k. geol. Reichs.*, bd. xlii, pp. 361-376. [1892.]
3717. **Jahn, J. J.** Einige Bemerkungen über das böhmische Siltur und über die Bildung des Erdöls. *Verh. k.-k. geol. Reichs.*, 1893, pp. 372-379.
- Jahn, K.**, see **Benko, G.**
3718. **James, G. D.** The San Juan Oilfield of Utah. *Eng. Min. Journ.*, vol. xcii, pp. 1082-1084. [1911.]
3719. **James, J. F.** Account of a Well drilled for Oil or Gas at Oxford, Ohio, May and June 1887. 8vo, *Cincinnati*, 1887.
3720. **James, R.** A Medicinal Dictionary; including Physic, Surgery, Anatomy, Chemistry, Botany, etc. 3 vols. folio, *London*, 1743-1745.
3721. **Jameson, E.** Geology of the Leavenworth Prospect Well. *Trans. Kansas Ac. Sci.*, vol. xi, pp. 37, 38. [1889.]
3722. **Jameson, R.** A System of Mineralogy. . . 3 vols. 8vo, *Edinburgh*, 1804-1808.
3723. **Jameson, W.** First Report of his deputation by the Government to examine the effects of the great Inundation of the Indus. *Journ. As. Soc. Beng.*, vol. xii, pp. 183-225. [1842.]
3724. **Jamison, C. E.** Mineral Resources of Wyoming. *Wyoming State Geologist Bull.*, ser. B, no. 1. [1911.]
3725. ——— Geology and Mineral Resources of a Portion of Fremont County, Wyo. *Ibid.*, no. 2. Pp. 90, 11 pls. map. [1911.]
3726. **Janin, C.** Examination of Petroleum Properties. *Min. Sci. Press*, vol. ci, pp. 269, 270. [1910.]
3727. **Janke, L.**, and **A. Barth.** Eine einfache Petroleumuntersuchungsmethode. *Hann. Monatschr.*, bd. li, p. 97. [1879.]
3728. **Jasper, —**. Das Vorkommen von Erdöl in Unter-Elsass. 8vo, *Strasbourg*, 1890.
3729. ——— Das Vorkommen von Erdöl im Elsass. *Glückauf*, bd. xxxi, pp. 215-218. [1895.]
3730. ——— Gewinnung und Verwerthung von Asphalt auf dem Bergwerk Lobansu im Elsass. *Zeitschr. Berg-, Hüt.-Salin.*, bd. xliii, pp. 387-392. [1896.]
- Jassin, —**, see **Orgels, L.**
3731. **Jawein, L.** Ueber die gegenwärtige Lage der russischen Naphta-Industrie in Baku. *Allg. österr. Chem.-Techn.-Zeit.*, bd. v, pp. 49, 50, 61. [1887.]
- Jawein, L.**, see **Beilstein, F. F.**, and **Lamanski, S. I.**
3732. **Jayne, H. W.** The Testing of Coal Tar and Oils, and an improved Testing Still. *Journ. Amer. Chem. Soc.*, vol. xxv, pp. 814-818. [1903.]
3733. **Jazukovitch, N.** [Action of Oxygen on Paraffin, etc.] *Jurn. Russk. Fiz. Khim. Obsch.*, t. vii, pp. 260-262. [1875.]
3734. **Jean, F.** Analyse d'un mélange de cire, de paraffine, de stéarine et d'acide stéarique. *Bull. Soc. Chim. Paris*, sér. 3, t. v, pp. 3-5. [1891.]
3735. **Jeep, W.** Der Asphalt und seine Anwendung in der Technik. *Weimar*, 1867.
3736. **Jeffrey, E. C.** The Nature of some supposed Algal Coals. *Proc. Amer. Acad.*, vol. xvi, pp. 273-290, pls. 1-v. [1910.]
3737. **Jene, H. L.** Oil Shale Deposits, Blue Mountains, N.S.W. *Eng. Min. Journ.*, vol. xc, pp. 407, 408. [1910.]
3738. **Jenkins, F.** [Announcement of two new sites of Coal in Assam.] *Journ. As. Soc. Beng.*, vol. vii, pp. 169, 170. [1838.]
3739. **Jenney, W. P.** On the Formation of Solid Oxidized Hydrocarbons resembling Natural Asphalts by the Action of Air on Refined Petroleum. *Amer. Chem.*, vol. v, pp. 359-362. [1875.]
3740. ——— Graphitic Anthracite in the Parker Mine, Wood River, Idaho. *School of Mines Quarterly*, vol. x, pp. 313-315. [1889.]
3741. ——— The Chemistry of Ore-Deposition. *Trans. Amer. Inst. Min. Eng.*, vol. xxxiii, pp. 415-498. [1902.]
- Jerdan, D. S.**, see **Bone, W. A.**
3742. **Jerome, L. J.** Report for 1906, on the Trade and Commerce of Mexico. *Dipl. Cons. Rep.*, ann. ser., no. 3888. [1907.]
3743. **Jervis, W. P.** The Mineral Resources of Central Italy. 8vo, *London*, 1862.

3744. **Jervis, W. P.** I tesori sotterranei dell'Italie. 2 Tt. 8vo, Turin, 1873, 1874.
3745. ——— Del Combustibili Minerali d'Italia e della loro Importanza Economica. 8vo, Turin, 1879.
3746. **Jeserich, J.** Sizilianischer Asphalt. *Deutsch. Bau-Zeit.*, bd. xiii, p. 428. [1879.]
3747. **Jesinghaus, W.** Italienisches Petroleum auf dem Weltmarkt. *Naphtha*, bd. xiv, pp. 291, 292. [1906.]
3748. **Jeunesse, A.** Réglementation de l'industrie des huiles minérales. *Ann. Gén. Civ.* [sér. 1], t. vii, pp. 493-495. [1868.]
3749. **Jewell, W. R.** Factors in Cost of Oil Production. *Min. Sci. Press*, vol. ciii, pp. 44-46. [1911.]
3750. **Jezioranski, L.**, see **Engler, C.**
3751. **Jidkov, N.** [Acidity of Grozni Petroleum.] *Trudi Bak. Otd. Russ. Imp. Techn. Obsch.*, 1898.
3752. **Joannini, G.** Schutz eiserner Brückentafeln durch Asphaltbettung. *Asphalt-Teerind.-Zeit.*, bd. iv, pp. 82, 99, 100. [1904.]
3753. **Job, R.** Notes on Testing Turbine Oil. *Proc. Amer. Soc. Test. Mat.*, vol. ix, pp. 614-618. [1905.]
3754. **Joel, L.** Report for 1886 on the Trade of Cadiz and the Province of Andalusia. *Dipl. Cons. Rep.*, ann. ser., no. 62. [1887.]
3755. **Joffre, J.** Sur l'analyse de combustibles minéraux nouvellement exploités en Ecosse. *Bull. Soc. Chim. Paris*, sér. 2, t. x, p. 8. [1868.]
3756. ——— Recherches sur les Huiles Minérales de Buxière-la-Grue et de Cordesse. *Ibid.*, sér. 2, t. xix, pp. 547-550. [1873.]
3757. **Johanson, E.** Festes Petroleum. *Pharm. Zeitschr. Russl.*, bd. xx, pp. 831-834. [1881.]
3758. **John, C. v.** Bergherthe und Ozokerit von Oran (Algier). *Verh. k.-k. geol. Reichs.*, 1879, pp. 104, 105.
3759. ——— Untersuchung zweier ungarischer Rohpetroleumvorkommen. *Ibid.*, 1884, pp. 53, 54.
3760. ——— Ueber die chemische Beschaffenheit der Asphaltchiefer der Barabai (Buru). *N. Jahrb.*, beil.-bd. xxii, pp. 691, 692. [1906.]
3761. **John, C. v.**, and **C. F. Eichleiter.** Arbeiten aus dem chemischen Laboratorium der k.-k. geologischen Reichsanstalt ausgeführt in den Jahren 1895-1897 xii, Erdöl. *Jahrb. k.-k. geol. Reichs.*, bd. xvii, pp. 763, 764; bd. i, pp. 663-694; bd. liii, pp. 481-514. [1897-1903.]
3762. **John, C. v.**, and **H. B. v. Foulon.** Arbeiten aus dem chemischen Laboratorium der k.-k. geologischen Reichsanstalt. *Jahrb. k.-k. geol. Reichs.*, bd. xxxi, pp. 483-518; bd. xxxvi, pp. 329-354; bd. xxxviii, pp. 617-632. [1882, 1886, 1888.]
3763. **Johns, W. R.**, see **Conne, A.**
3764. **Johnson, E.** Oil Barges. *Marine Engineering*, vol. viii, pp. 230-233. [1902.]
3765. **Johnson, H. R.**, see **Arnold, R.**
3766. **Johnson, E. H.** Theories of Oil- and Gas-Accumulation. *Econ. Geol.*, vol. v, pp. 63, 64. [1910.]
3767. ——— Marking Oil Maps. *Ibid.*, pp. 273-277. [1910.]
3768. ——— Oil Lands of the Mid-Continent Field. *Oil Investors' Journ.*, vol. viii, pp. 27, 28. [1910.]
3769. ——— Composition of Oklahoma and Kansas Petroleum. *Ibid.*, p. 32. [1910.]
3770. ——— Methods of Prospecting, Development and Appraisal in the Mid-Continent Field. *Ibid.*, pp. 70-73. [1910.]
3771. ——— Oil Pools in the Northern Part of the Cherokee Nation at the end of 1909. *Ibid.*, pp. 73-75, map. [1910.]
3772. ——— Offsetting Wells. *Ibid.*, May 20, 1910.
3773. **Johnston, A. R.** Remarks on the Geology of the vicinity of Fort Washita. *Proc. Amer. Assoc. Geol. Nat.*, 1845, pp. 74-77.
3774. **Johnston, J. F. W.** On a new variety of Mineral Resin. *Edinb. Journ. Sci.*, vol. iv, pp. 122-124. [1831.]
3775. ——— Description and Analysis of a variety of Hatchetite, found in Urpeth Colliery, near Newcastle. *Trans. Northumb. Nat. Hist. Soc.*, vol. ii, pp. 391-400. [1832.]
3776. **Johnston, J. F. W.** On the composition of certain mineral substances of organic origin. I. Middletonite. II. Hatchetite. III. Ozokerite from Urpeth Colliery, near Newcastle-upon-Tyne. IV. Betinasphalt. V. Elastic Bitumen of Derbyshire. VI. Guayaquilite. VII, VIII. [Mineral Resins.] *Phil. Mag.*, ser. 2, vol. xii, pp. 261-263, 338, 339, 389-396, 567-564; vol. xiii, pp. 22-25, 329-333 [1838]; vol. xiv, pp. 87-95 [1839].
3777. ——— On the Origin of Petroleum, and on the Nature of the Petroleum from Whitehaven. *Rep. Brit. Assoc. for 1838*, sect., p. 60. [1839.]
3778. **Johnston, L. C.** Notes on Petroleum. *Witwatersrand Min. Metallurg. Rev.*, no. 8, pp. 4-8. [1890.]
3779. **Johnston, R. M.** Tasmanite or Mersey "Yellow Coal." 8vo, Hobart Town, 1877.
3780. **Joly, J.** On a Method of Determining the Specific Gravity of Small Quantities of Dense or Porous Bodies. *Proc. R. Dublin Soc.*, vol. v, pp. 41-47. [1887.]
3781. **Jones, A. C.** On the Removal of Obstructions in the Mouth of the Mississippi. *Journ. Franklin Inst.*, ser. 3, vol. ii, pp. 83-87. [1841.]
3782. **Jones, E. C.** The Development of Oil-Gas in California. *Proc. Amer. Gas Inst.*, vol. iv, pp. 410-452. [1909.]
3783. ——— Producer Gas from Crude Oil. *Trans. Amer. Soc. Mech. Eng.*, vol. xxxiii, pp. 903-906. [1911.]
3784. **Jones, F.** On the Action of Alkalies on Glass and on Paraffin. *Mem. Lit. Phil. Soc. Manch.*, vol. xvii, art. 3. [1902.]
3785. **Jones, H. M.** Report for 1887 on the Trade of Eastern Roumelia. *Dipl. Cons. Rep.*, ann. ser., no. 325. [1888.]
3786. ——— Report on the Trade of Siam for 1890. *Ibid.*, no. 338 [1891.]
3787. **Jones, H. O.**, and **H. A. Wootton.** The Chemical Composition of Petroleum from Borneo [Kutel]. *Journ. Chem. Soc.*, vol. xci, pp. 1146-1149. [1907.]
3788. **Jones, J. E.** New Oil Fields (Alberta). *U.S. Cons. Rep.*, no. 356, p. 137. [1910.]
3789. ——— Asphalt Industry, Canada. Winnipeg New Municipal Asphalt Plant. *Ibid.*, no. 357, pp. 193, 194. [1910.]
3790. **Jones, L. M.**, see **Thorpe, T. E.**
3791. **Jones, S.** Some particulars regarding the Mineral Productions of Bengal. *Glean. Sci.*, vol. i, pp. 281-286. [1829.]
3792. **Jones, T. R.** Note on the Orbitoides and Nummulina of the Tertiary Asphaltic Bed, Trinidad. *Quart. Journ. Geol. Soc.*, vol. xxii, pp. 592, 593. [1866.]
3793. **Jones, W. F.** Geology of the Sargent Oil Field (California). *Geol. Bull. Univ. Calif.*, vol. vi, pp. 55-78. [1911.]
3794. **Jonine, N.**, see **Schützenberger, P.**
3795. **Jordan, E. T. J.** Reports of the State Natural Gas Supervisor for 1891 [2, 3]. *Ann. Rep. Geol. Indiana*, vol. xvii, pp. 326-364; vol. xviii, pp. 196-218; vol. xix, pp. 123-145. [1892-1894.]
3796. **Jordan, J. L.** Mineralogische und chemische Beobachtungen und Erfahrungen. *Göttingen*, 1800.
3797. ——— Aeusser Beschreibung und einige chemische Versuche mit dem elastischen Erdharze (mineral elastic gum, elastic bitumen); *Franz.*, Caoutchouc fossile.) *Chem. Ann.*, bd. i, pp. 354-360. [1801.]
3798. **Jordan, P.** Note sur l'Industrie minière au Japon. *Ann. Mines*, sér. 9, t. xiv, pp. 530-556, pl. viii (map). [1898.]
3799. **Jordanus (Friar, ca. 1330).** Mirabilia Descripta. The Wonders of the East. 8vo, London (Hakluyt Soc.), 1863.
3800. **Jordery, C. A.**, and **N. M. Paschkoff.** Solidification du pétrole. *Journ. Eclair. Gaz*, t. xx, pp. 278, 279. [1872.]
3801. **Journolleau, L.** Le pétrole en Mandchourie. *Compt. Rend. Soc. Ind. Min.*, 1909, pp. 534, 535.

2797. **Jucho, F.** Ueber die Erweiterung des Grubenbetriebes und die neue Werksanlage bei Thorda [Siebenbürgen]. *Berg-Hütt. Jahrb. Wien*, bd. xiii, pp. 135-316. [1863.]
2798. **Judd, E. K.** Asphaltum. *Min. Ind.*, vol. xv, pp. 59-64. [1907.]
2799. **Judson, W. P.** Road Preservation and Dust Prevention. 8vo, London, 1908.
2800. **Jugler, J.** Ueber Petroleumvorkommen in Parma und Modena. *Berg-Hütt.-Zeit.*, bd. xxix, p. 44. [1870.]
- Jukes-Browne, A. J.**, see **Harrison, J. B.**
2801. **Jukovski, S.** [New Metallurgical Oil-Forges.] *Gorn. Journ.*, 1896, t. 3, pp. 14-51, 5 pls.
2802. **Julia de Fontenelle, J. S. E.** Sur un gisement de caoutchouc minéral et de gomme fossile, trouvés dans les mines de houille de la Vendée. *Congr. Sci. Franc.*, 1833, pp. 35, 36.
- Julia de Fontenelle, J. S. E.**, see **Payen, A.**
2803. **Julien, A.** Sur l'existence de flons de bitume dans le granite des environs de Clermont-Ferrand. *Compt. Rend.*, t. lxxxiv, pp. 717, 718. [1877.]
2804. **Junghuhn, F.** Java deszelsz gedaante, bekleeding en inwendige Structuur. *Amsterdam*, 1850-1853.
2805. ——— Brief Gericht aan Zijne Excellentie de Gouverneur General von Ned.-Indie omtrent de Exploitatie van Aardolie op Java. *Tijdschr. Nijverh. Landb. Ned. Ind.*, dl. xi, pp. 357-361. [1865.]
2806. **Junginger, E.** Bereltung leicht und bestandig emulgiobarer Mineralöle und Mineralölsäuren, welche klare Lösungen ergeben. *Seifensied.-Zeit.*, bd. xxxiv, pp. 337, 338. [1907.]
2807. **Jurulj, —.** [Map of the Grozni Oil-Field, Terek Province, 1:210,000.] *Vladikavkaz*, n.d.
2808. **Jussen, E.** The Petroleum Works of Austria. *Rep. Cons. U.S.*, vol. xix, pp. 151-166. [1886.]
2809. **Jusseraud, E.** Rapport sur la notice sur les causes de l'apparition du bitume dans la Limagne d'Anvergne. *Ann. Sci. Industr. Stat. Auvergne*, t. xxv, pp. 451-455. [1852.]
2810. **Just, G.** Ueber Benzinbrände. *Zeitschr. Elektrotechn.*, bd. x, pp. 202-204. [1904.]
2811. **K—.** Neuer Erdöldestillirkessel. *Polyt. Journ.*, bd. cxciv, p. 212. [1894.]
2812. **K—, G.** Die Asphaltgruben von San Valentino in Italien. *Oesterr. Zeitschr. Berg-Hütt.*, bd. li, pp. 732-735. [1903.]
2813. **K—, T. W.** American Petroleum. *London Journ. Arts. Sci.*, ser. 4, vol. xvi, pp. 257-259. [1862.]
2814. **K—, W.** Die Petroleumindustrie in den Vereinigten Staaten von Nord-Amerika. *Berg-Hütt.-Zeit.*, bd. xxxvi, pp. 16, 17, 21-23. [1877.]
2815. **Kaemmerer, W.** Die Erdölgewinnung bei Wietze (Prov. Hannover). *Zeitschr. Ver. Deutsch. Ing.*, bd. xlix, pp. 1555-1561. [1905.]
2816. **Kaempfer, E.** Decas Observationum Exoticarum. *Leyden*, 1694.
2817. ——— Ammenitatum Exoticarum Politico-Physico-Medicarum fasciuli quinque, quibus continetur varis Relationes, Observationes et Descriptiones Rerum Persicarum et Uterioris Asiae. 4to, *Lemgo*, 1712.
2818. **Kaempfer, E. (2).** Use of Oxygen in Oil Wells for removal of Paraffine. *Min. Sci. Press*, 1871, p. 98.
2819. **Kalb, C. de.** A Simple Oil-burning Equipment. *Eng. Min. Journ.*, vol. lxxxi, p. 74. [1906.]
2820. ——— The California Oil Industry. *Min. Sci. Press*, vol. c, pp. 857-859. [1910.]
2821. **Kalecsinszki, A.** Mittheilungen aus dem chemischen Laboratorium der kgl. ungar. geologischen Anstalt. *Jahresb. k. ungar. geol. Anst.*, 1855, pp. 192-202; 1857, pp. 189-199; 1896, pp. 198-203; 1897, pp. 226-238. [1886-1899.]
2822. ——— [Crude Petroleum of the Carpathian Range.] *Földt. Kéz.*, köt. xxvii, p. 511. [1897.]
2823. **Kalitzkii, K. I.** [Geological Researches in the Petrowsk District, Daghestan, 1901.] *Bull. Com. Géol. Russ.*, t. xxi, pp. 671-696. [1902.]
2824. **Kalitzkii, K. I.** [Grozni Oil Region]. *Mém. Com. Géol. Russ.*, n.s., no. 24. Pp. 40, 3 pls., 3 maps. [1906.]
2825. ——— [Tchatain Oil Field]. *Bull. Com. Géol. Russ.*, t. xxvi, pp. 127-180, pl. ii; (discussion) *Journ.*, pp. 14-27. [1907.]
2826. ——— [Oil Deposits of Tcheleken]. *Mém. Com. Géol. Russ.*, n.s., no. 59. Pp. vii, 108; 8 pls. and map. [1910.]
- Kalitzkii, K. I.**, see **Bogdanovitch, K. I.**; and **Weber, V.**
2827. **Kahn, P.** En resa til Norra Amerika. 3 Tt. 8vo, *Stockholm*, 1753-1761.
2828. **Kalmann, W.** Feuerversicherung bei Verwendung mineralöhlhaltiger Spicköle. *Compt. Rend. Congr. internat. Chem. Appl.*, sess. 3, t. i, pp. 264-266. [1899.]
2829. **Kamenski, —.** [Petroleum Residues as Fuel for Steamship Boilers.] *Zap. Imp. Russk. Tekhn. Obsch.*, g. iv, otd. 2, pp. 452-456, pl. [1870.]
2830. **Kandukina, T. N.** Le Gisement de Naphte de Nijne Bourkatchinskoe, Distr. de Sterlitamak, Gov. d'Oufa. *Bull. Soc. Oural. Sci. Nat.*, t. xxvi, pp. 66-74, pl. [1907.]
2831. **Kanitz, J.** Rumanian Petroleum Industry. *Petrol. Rev.*, vol. vi, pp. 48, 71, 72, 104. [1902.]
2832. ——— The Growth of the Roumanian Petroleum Industry. *Petroleum*, vol. ii, pp. 604-608, 658-661, 712, 713. [1902.]
2833. ——— The Rumanian Industry in 1902. *Monit. Int. Petrol. Roum.*, t. iv, 1903.
2834. **Kankelwitz, W.** Ueber die Gewinnung des Mineralöls und des Paraffins. *Zeitschr. Ver. Deutsch. Ing.*, bd. i, pp. 42-45, 147-152; bd. ii, pp. 31-38. [1857, 1858.]
2835. **Kanorowicz, —,** and — **Keisermann.** Ueber die Prüfung von Lackbenzin. *Chem.-Zeit.*, bd. xxv, pp. 1374, 1375. [1911.]
2836. **Kao, D.** An Authentic Account of whatever is most remarkable in regard to persons or things throughout the whole Empire of China, with a description of Japan, Corea, Formosa, Tunkin, and Laos, etc. [In vol. ii of *Navigantium atque Itinerantium Bibliotheca*, by J. Harris. 2 vols. *For. London*, 1764.]
2837. **Karlovitch, V. M.** [On the Comparative Cost of Carrying Oil by Pipe-line and by the Trans-Caucasian Railway.] *Zap. Imp. Russk. Tekhn. Obsch.*, g. xix, Trudi, otd. I, pp. 185-199. [1885.]
2838. **Karmarsch, K.** Ueber Asphalt, insbesondere die Beschaffenheit des in der Nähe von Hannover aufgefundenen. *Mith. Gewerbe-Ver. Hannover*, 1844-1845, pp. 21-28.
2839. **Karmarsch, K.**, and **F. Heeren.** Technisches Wörterbuch; oder Handbuch der Gewerbkunde in alphabetischer Ordnung. 3 Bde. 8vo, *Prague*, 1854-1857.
2840. **Karpov, Ph.** [Oil-Industry of the Terek Province.] *Tersk. Sbornik*, 1890, pp. 201-274.
2841. **Karpovitch, —.** [Footways of Compressed Asphalt.] *Inj. Journ.*, 1865, pp. 577, 578.
2842. ——— *Balneologie of the Tiflis Government*, 1871.
2843. **Karsten, C. J. B.** Metallurgische Reise durch einen Theil von Baiern und durch die Silddeutschen Provinzen Oesterreichs. 8vo, *Halle*, 1821.
2844. **Karsten, D. L. G.** Mineralogischen Tabellen, mit Rücksicht auf der neuesten Entdeckungen. *For. Berlin*, 1800.
2845. ——— Kurze Nachricht über das in der Neumark gefundene Erdpech. *N. Schr. Ges. Nat. Freunde, Berlin*, bd. iv, pp. 335, 336. [1803.]
2846. **Karsten, H.** Saxon Lignite. *Zeitschr. deutsch. geol. Ges.*, bd. li, p. 71. [1850.]
2847. ——— Geognostische Bemerkungen über die Nordküste Neu-Granada's, insbesondere über die sogenannten Vulcanen von Turbaco und Zamba. *Ibid.*, bd. iv, pp. 579-583. [1862.]
2848. ——— Geognostische Bemerkungen über die Umgebungen von Maracaybo und über die Nordküste von Neu-Granada. *Arch. Min. Geogn.*, bd. xxv, pp. 567-573. [1853.]

3849. **Karsten, H.** Ueber die geognostischen Verhältnisse des westlichen Colombien der heutigen Republiken Neu-Granada und Ecuador. *Ann. Ber. Versamm. deutsch. Nat. Wien*, 1856, pp. 85, 86. [1853.]
3850. ——— Beitrag zur Kenntniss des Verwesungsprocesses. *Monatsb. k. preuss. Ak. Wiss.*, 1860, pp. 38-44.
3851. ——— Géologie de l'Ancienne Colombie Bolivarienne, Vénéuela, Nouvelle-Grenade et Ecuador. 4to, Berlin, 1886.
3852. **Kassler, F.** Ueber die Bildung von Kohlenwasserstoffen bis der Destillation von Fettsäuren. *Chem. Rev. Fett-Harz-Ind.*, bd. x, pp. 151-154. [1903.]
3853. **Kast, H.**, and **A. Künkler.** Ueber ägyptisches Erdöl. *Polyt. Journ.*, bd. cclxxviii, pp. 34-42. [1890.]
3854. **Kast, H.**, and **G. Lagai.** Ueber Schwefelverbindungen im Erdöl. *Ibid.*, bd. cclxxxiv, pp. 69-72. [1892.]
3855. **Kast, H.**, and **F. Rose.** Ueber die Zusammensetzung des in Erdölampfen sich bildenden Gasmisches und den Entflammungspunkt des Erdöls. *Ibid.*, bd. ccc, pp. 87-94. [1896.]
3856. **Kast, H.**, and **S. Seidner.** Zur Bildung des Erdwaches. *Ibid.*, bd. cclxxxiv, pp. 6, 143, 144. [1892.]
3857. **Kasten, H. W.** [Documents on Age of Hanoverian Petroleum, sent to the Paris Exhibition, 1867.] *Ann. Mines*, sér. 6, t. xii, p. 638. [1867.]
3858. **Kastner, K. W. G.** Brenzliches Wasserstoffgas. *Arch. Naturk.*, bd. II, pp. 239-241. [1824.]
3859. ——— Ueber den Gehalt durch Erbrand entstandener heisser Quellen. *Ibid.*, bd. xvi, pp. 331-361. [1829.]
3860. ——— Ueber das Vorkommen von gasigen Hydrogen und brennbaren gasigen Carbonverbindungen in der atmosphärischen Luft. *Ibid.*, bd. xxvii, pp. 298-302. [1835.]
3861. **Katzer, F.** . . . II. Ueber Vorkommen von Anthraciten im älteren Palaeozoicum Mittelböhmens. . . . *Verh. k.-k. geol. Reichs.*, 1893, pp. 198-206.
3862. ——— Beiträge zur Mineralogie Böhmens, III. *Min. Petr. Mith.*, n.f., bd. xvi, pp. 504-518. [1897.]
3863. **Kauer, A.** and **G. Bizio.** Analyse eines Gasmenges das aus dem Brunnen in Campo St. Paolo zu Venedig entweicht. *Sitz. k. Ak. Wiss. Wien*, bd. xlv, th. 2, pp. 69, 70. [1861.]
3864. **Kaufmann, C.** [Mining Industry in the Budapest Region in 1892 and 1893.] *Bányász. Kohász. Lapok.*, evf. xxvi, xxvii, 1893, 1894.
3865. ——— [Tataros Asphalt Mine and Method of Operation.] *Ibid.*, evf. xxx, 1897.
3866. **Kaufmann, F. J.** Ueber den Doppelrit von Obbürgen, und über das Verhältniss des Doppelrits zu Torf und mineralischen Kohlen, nebst Bemerkungen über künstliche pechkohlenartigen Substanzen. *Jahrb. k.-k. geol. Reichs.*, bd. xv, pp. 283-296. [1865.]
3867. **Kaunhowen, F.** Ueber einige Mikroorganismen der fossilen Brennstoffe (Cannelkohlen, Torf, Bogheads). *Zeitschr. prakt. Geol.*, bd. ix, pp. 46-52, 97-110. [1901.]
3868. **Kaysner, —.** Kurze Mittheilungen über Petroleum. *Bresl. Gewerbell.*, bd. x, p. 27. [1864.]
3869. **Kaysner, H.** Modernes Asphaltpflaster in Amerika. *Asphalt-Teerind.-Zeit.*, bd. vi, pp. 345-347, 363-366, 378-381, 395-397, 410-412. [1906.]
3870. **Kaysner, R.** Untersuchungen über natürliche Asphalte mit Berücksichtigung ihrer photochemischen Eigenschaften. *Nürnberg*, 1879.
3871. **Kazankin, M. P.** The Specific Gravities of Russian Crude Oil and its Products at various Temperatures. *Petrol. Rev.*, vol. xiv, p. 294. [1906.]
3872. **Kean, F. J.** Some Test Figures from an Oil Engine. *Trans. Inst. Marine Eng.*, vol. xxii, pp. 149-168. [1910.]
3873. **Keane, C. A.** Modern Organic Chemistry. 8vo, London, 1909.
3874. **Keck, R.** The Genesis of Ore Deposits. *Eng. Min. Journ.*, vol. xxxv, pp. 3, 4. [1883.]
3875. **Kedzie, R. C.** Address on the Illuminating Oils of Michigan. *Fifth Ann. Rep. Michigan State Board of Health.* Lansing, 1877.
3876. ——— Historical Review of legislation relating to inspection of illuminating oil in Michigan. *7th Ann. Rep. Michigan State Board of Health.* Lansing, 1879.
3877. **Kedzie, W. K.** The Iola (Kansas) Mineral Well. *West. Rec. Sci. Ind.*, vol. i, pp. 257-260. [1878.]
3878. **Keene, W.** On the Examination of Brown Cannel or Petroleum Coal Seams at Colley Creek, Liverpool Plains, New South Wales. *Quart. Journ. Geol. Soc.*, vol. xxii, pp. 435-438. [1866.]
3879. **Keferslein, Ch.** Tabellarisches Verzeichniss der Quellen die viel Bittersalz, Glaubersalz, Kohlensäures Natron, Borax, Salpeter, Schwefelsäure und ähnliche Körper, auch Erdöl, in besonderer Menge mit sich führen. *Zeit. Geogn.*, bd. vi, pp. 18-28. [1828.]
3880. **Keijero, Nishio.** The Mining Industry of Japan. *Trans. Amer. Inst. Min. Eng.*, vol. xlii, [1912.]
3881. **Keisermann, —.** see Kantorowicz, —.
3882. **Keith, A.** Wartburg (Tenn.) Fo 40, *U. S. Geol. Surv.* 1879.
3883. **Kellaer, G. J.** Petroleum in Orange River Colony (Süd-Afrika). *Zeitschr. prakt. Geol.*, bd. xvi, pp. 283, 284. [1908.]
3884. **Kemp, J. F.** The Precipitation of Metallic Sulphides by Natural Gas. *Eng. Min. Journ.*, vol. i, p. 689. [1890.]
3885. ——— The Deposits of Copper Ore at Ducktown (Tenn.). *Trans. Amer. Inst. Min. Eng.*, vol. xxxi, pp. 244-265. [1902.]
3886. **Kennedy, W.** Geology of Jefferson County, Texas. *Amer. Geol.*, vol. xiii, pp. 268-275. [1891.]
3887. ——— Oil as a Fuel. *Southern Industr. Lumber Rev.*, 1901.
3888. **Kennedy, W.** see Hayes, C. W.
3889. **Kennel, — v.** Die Insel Trinidad. *Sitz. nat. Ges. Dorpat*, bd. ix, pp. 120-149. [1889.]
3890. **Kennigott, G. A.** Ueber den Doppelrit. *Jahrb. k.-k. geol. Reichs.*, bd. i, pp. 303-306. [1850.]
3891. **Keppel, G.** Journey from India to England, by . . . Bagdad . . . Caspian Sea . . . 1824 to, London, 1827.
3892. **Keppen, A.** [Mining Industry of Russia.] 8vo, St. Petersburg, 1893.
3893. **Kermode, —.** Liquid Fuel Apparatus for Water-tube Boilers. *Engineering*, vol. lxxxix, pp. 510-512. [1910.]
3894. **Kern, —.** Origin of Petroleum. *Chem. News*, vol. iii, p. 922. [1877.]
3895. **Kerndt, T.** Encyclopädie der chemisch-technischen Wissenschaften. 8vo, Leipzig, 1858-1860.
3896. **Kersten, C. M.** Notiz über einen in Brauneisenstein und Bitumen umgewandelten Menschenschädel. *Ann. Phys. Chem.*, bd. cxxix, pp. 387-390. [1841.]
3897. ——— Ueber das Vorkommen des Asphalts und dessen Zusammensetzung auf der Insel Brazza und einigen andern Punkten Dalmatiens. *Journ. prakt. Chem.*, bd. xxxv, pp. 271-277. [1845.]
3898. **Kessler, P.** Das deutsche Erdöl, seine Verarbeitung und Verwendung. *Zeitschr. angew. Chem.*, bd. xxiii, pp. 1697-1704. [1910.]
3899. **Key, W.** Petrol Air-Gas. *Journ. Gaslighting*, vol. cx, pp. 496-498. [1910.]
3900. **Keyes, C. R.** Natural Gas and Oil in Iowa. *Proc. Iowa Acad. Sci.*, vol. i, pp. 15-18. [1891.]
3901. **Keyserling, A. v.** Ueber den Domanik. *Verh. russk. k. min. Ges.*, 1845-46, pp. 144-160.
3902. ——— [On the Grozni Oil.] *Gorn. Journ.*, 1894, t. 1, pp. 259-261.

3903. **Kharitchkov, K. V.** [Oil from the Derbent district, Kaitago-Tabassaran deposit.] *Trudi Bak. Old. Imp. Russk. Tekhn. Obsch.*, 1894, March, pp. 9-17.
3904. ——— [Tarry Oil of the Balakhan-Sabuntchi Field.] *Ibid.*, 1894, March, pp. 18-20.
3905. ——— [New Oil-ground in the Kaukasus: Khidirzindi.] *Ibid.*, 1895, April, pp. 1-18.
3906. ——— [Petroleum and Ozokerite of Tcheleken Island.] *Ibid.*, June, pp. 16-27. [1895.]
3907. ——— [Influence of the Resinous Constituents of Petroleum upon its Illuminating Power.] *Ibid.*, Oct., pt. 1, p. 39. [1895.]
3908. ——— [Methods of Analysis of Petroleum.] *Jurn. Russk. Fiz. Khim. Obsch.*, t. xxvii, pp. 496-500. [1895.]
3909. ——— [Analysis of Petroleum from Tcheleken Island.] *Ibid.*, pp. 595-597. [1895.]
3910. ——— [Chemistry of the Formation of Petroleum.] *Ibid.*, t. xxviii, pp. 825-828. [1896.]
3911. ——— [Origin of Petroleum.] *Novoe Obozren.*, 1896, nos. 4342, 4345, 4359.
3912. ——— [Oil-search at Derbent.] *Trudi Bak. Old. Imp. Russk. Tekhn. Obsch.*, 1896, pp. 1-15.
3913. ——— [Action of Petroleum Products on Aluminium.] *Trudi Bak. Old. Imp. Russk. Tekhn. Obsch.*, 1896, p. 16.
3914. ——— [On the method of Engler and Zalozecki to determine Paraffin in Petroleum.] *Ibid.*, pp. 204-209.
3915. ——— [Der Naptha-Reichthum der Insel Tschelaken.] *Chem. Rev. Fett-Harz-Ind.*, bd. iii, pp. 86-88. [1896.]
3916. ——— [Kann das Vorkommen von Stickstoff im Erdöl als unumstößlicher Beweis für dessen Abstammung aus organischen Stoffen dienen? *Chem. Rev. Fett-Harz-Ind.*, bd. iv, pp. 289, 290. [1897.]
3917. ——— [The Sulphur Coefficient of the Grozni Benzine.] *Trudi Bak. Old. Imp. Russk. Tekhn. Obsch.*, 1897, pp. 272-286.
3918. ——— [Variations in the Specific Gravity of Petroleum Products by Loss of certain Volatile Constituents.] *Ibid.*, p. 354. [1897.]
3919. ——— [On Certain Properties of Petroleum-Acids and the Utilisation of Refinery Waste.] *Ibid.*, p. 568. [1897.]
3920. ——— [Kerosene Stove for Elementary Analysis, with Primus Burner.] *Jurn. Russk. Fiz. Khim. Obsch.*, t. xxix, otd. 1, pp. 63-66. [1897.]
3921. ——— [The Chemistry of the Formation of Petroleum.] *Ibid.*, pp. 151-170. [1897.]
3922. ——— [Sulphur Compounds in Grozni Benzine.] *Ibid.*, pp. 415-420. [1897.]
3923. ——— [On some Properties of Naphthene Salts, and their differences from those of Fatty Acids.] *Ibid.*, pp. 691-696. [1897.]
3924. ——— [Petroleum as a Mineral.] *Ejegođn. Geol. Min. Ross.*, t. ii, tch. 3, pp. 70-74. [1897.]
3925. ——— [Present state of the Regulations on Illuminant Oils.] *Zap. Imp. Russk. Tekhn. Obsch.*, g. xxxi, Trudi, pp. 1-26. [1897.]
3926. ——— [Alkaline Lye from Petroleum Refineries and its use in the manufacture of Timber-preservatives.] *Ibid.*, g. xxxii, Trudi, pp. 667-685. [1898.]
3927. ——— [Elementary Composition and Heating Power of the Petroleum Residues of Grozni.] *Gorn. Journ.*, 1898, t. 1, pp. 352-355.
3928. ——— [Nitrogen in Russian Petroleum in relation to the hypothesis of inorganic origin.] *Ibid.*, pp. 356-358.
3929. ——— [Progress of Benzine Production in Russia.] *Ibid.*, t. 4, pp. 83-91.
3930. ——— [Heptane in Grozni Naphtha.] *Jurn. Russk. Fiz. Khim. Obsch.*, t. xxxi, otd. 1, pp. 562-554. [1899.]
3931. ——— [Composition of Naphtha from Grozni.] *Ibid.*, pp. 655-658. [1899.]
3932. ——— [Naphta im Transkaspischen Gebiet.] *Chem. Rev. Fett-Harz-Ind.*, bd. vi, pp. 49, 51. [1899.]
3933. **Kharitchkov, K. V.** [Behaviour of Grozni Petroleum under the Acid Test.] *Trudi Bak. Old. Imp. Russk. Tekhn. Obsch.*, 1899, p. 256.
3934. ——— [On the Establishment of Uniform Methods of Testing Petroleum Products.] *Ibid.*, p. 257.
3935. ——— [Rhigolene.] *Nepht. Dielo*, 1899, p. 170.
3936. ——— [Distillation-test v. Flash-test.] *Ibid.*, 1900.
3937. ——— [Notes on the Chemical Analysis of Lubricants.] *Zap. Imp. Russk. Tekhn. Obsch.*, g. xxxiv, Trudi, pp. 1033-1037. [1900.]
3938. ——— [Normal Properties of Kerosene, in connection with the improvements in construction of lighting apparatus.] *Ibid.*, g. xxxv, Trudi, pp. 385-402. [1901.]
3939. ——— [Oil-refining with Lime.] *Naphta*, bd. ix, pp. 211-213. [1901.]
3940. ——— [The Treatment of Grozni Kerosene.] *Petrol. Rev.*, vol. iv, pp. 211, 215. [1901.]
3941. ——— [Decomposition-Products of Naphtha from Baku and Grozni.] *Viestn. Jirov. Vesch.*, t. ii, p. 183. [1901.]
3942. ——— [Die nächste Frage der Leuchtöltechnik.] *Chem. Rev. Fett-Harz-Ind.*, bd. viii, pp. 113-115. [1901.]
3943. ——— [Two Types of Tcheleken Petroleum.] *Sborn. Tersk. Old. Imp. Russk. Tekhn. Obsch.*, 1901, pp. 28, 29.
3944. ——— [Petroleum of Lyakyan, Ferghana.] *Nepht. Dielo*, 1901.
3945. ——— [Research in Grozni Petroleum, and Inferences drawn as to Methods of Distillation on scientific Principles.] *Zap. Imp. Russk. Tekhn. Obsch.*, g. xxxvi. [1902.]
3946. ——— [Characteristics and Constituents of Petroleum from Grozni.] *Viestn. Jirov. Vesch.*, t. iii, p. 133. [1902.]
3947. ——— [On the Question of the suitability of heavy Naphtha and Petroleum-residues for the manufacture of Mineral Lubricants.] *Ibid.*, p. 351. [1902.]
3948. ——— [On the Inapplicability of Winkler's Method to the Analysis of Natural Gas.] *Jurn. Russk. Fiz. Khim. Obsch.*, t. xxxiv, otd. 1, pp. 393-395. [1902.]
3949. ——— [Ferghana Petroleum.] *Ibid.*, pp. 395-397. [1902.]
3950. ——— [Fractional Combustion of Hydrogen Carbonic Oxide and Isopentane.] *Ibid.*, pp. 461-465. [1902.]
3951. ——— [Elementary Composition and Classification of Russian Petroleum.] *Ibid.*, pp. 629-632. [1902.]
3952. ——— [Optical Properties of Petroleum from Texas.] *Ibid.*, p. 643. [1902.]
3953. ——— [Fractional Combustion of Methane and Hydrogen on C. Winkler's method.] *Ibid.*, pp. 710, 711. [1902.]
3954. ——— [Gas discharged in the Bay of Baku.] *Ibid.*, pp. 712-720. [1902.]
3955. ——— [On the Carbonaceous Substances in Caucasian Petroleum.] *Ibid.*, t. xxxv, otd. 1, pp. 695-701. [1903.]
3956. ——— [The Manufacture of Petroleum Lamps in Western Europe.] *Nepht. Dielo*, 1903.
3957. ——— [Some Notes on Berekel Petroleum.] *Grozni*, 1903.
3958. ——— [Die fractionirte Trennung der Petroleum-Kohlenwasserstoffe in der Kälte.] *Chem. Rev. Fett-Harz-Ind.*, bd. x, pp. 251, 281, 282; bd. xi, pp. 9, 10. [1903, 1904.]
3959. ——— [Application of Wagner's Method to Gas Analysis.] *Jurn. Russ. Fiz. Khim. Obsch.*, t. xxxvi, otd. 1, pp. 22-24. [1904.]
3960. ——— [On the Nature of the Caucasian Natural Gas and the Causes of its Spontaneous Ignition.] *Ibid.*, p. 205. [1904.]
3961. ——— [Composition of Oil and Gas of Berekel (Daghestan).] *Ibid.*, pp. 321-326. [1904.]
3962. ——— [On the Origin of Petroleum.] *Ibid.*, pp. 1091-1096. [1904.]

3963. **Kharitchkov, K. V.** [Fractional Precipitation of Petroleum.] *Jurn. Russk. Fiz. Khim. Obsch.*, t. xxxvi, otd. 1, pp. 1126-1129. [1904.]
3964. ——— Ueber die Mittel, Naphta von ihren Destillaten und Naphtarésiduen zu unterscheiden. *Compt. Rend. Congr. internat. Chim. appl.*, sess. 5, t. II, pp. 508, 509. [1904.]
3965. ——— [New Fractionating Method for Classifying Liquid Bitumens.] *Viestn. Jirov. Vesch.*, t. v, p. 132. [1904.]
3966. ——— [Determination of Lubricant in Mazut.] *Ibid.*, p. 150. [1904.]
3967. ——— [Technical Requirements in Reagents for the Purification of Kerosene.] *Ibid.*, t. vi, p. 119. [1905.]
3968. ——— [Bleaching Distillation-residues of Petroleum.] *Ibid.*, p. 135. [1905.]
3969. ——— [Estimation of Water in Petroleum by Wielezynski's Centrifugal Method.] *Ibid.*, p. 187. [1905.]
3970. ——— [On the Production of Aniline Dyes from Petroleum.] *Trudi Bak. Otd. Imp. Russk. Tekhn. Obsch.* [1908, 1907.]
3971. ——— Neutrale in Petroleum und Schmierölen vorkommende Schwefelsäureester und die Bedeutung dieser Beimengung für die Reinigung von Mineralölen. *Naphta*, bd. xii, pp. 55, 56. [1905.]
3972. ——— Ueber die Anwendung des Verfahrens der Kalten Fraktionierung zur Analyse der Mineralölchemie und auf anderen Gebieten der Chemie. *Ibid.*, bd. xiv, pp. 331-333. [1906.]
3973. ——— [Cholesterin Reactions of Petroleum and Distillates.] *Nepht. Dielo*, 1906, pp. 1250, 1251, 1388.
3974. ——— [Some patented processes of separation and quantitative determination of tar in oil.] *Ibid.* [1906.]
3975. ——— [New Types of High-Viscosity Lubricants.] *Ibid.* [1906.]
3976. ——— [Chemical Examination of Petroleum.] *Viestn. Jirov. Vesch.*, t. vii, p. 14. [1906.]
3977. ——— [Attempts to obtain Petroleum of good quality without chemical refining.] *Ibid.*, p. 61. [1906.]
3978. ——— [Theory of the chemical purification of Kerosene and Benzine.] *Ibid.*, p. 124. [1906.]
3979. ——— [Synthesis of Petroleum with Calcium Carbide.] *Ibid.*, p. 180. [1906.]
3980. ——— Die Entwicklung der Naphta-Industrie in Grosny. *Petroleum Zeitschr.*, bd. I, pp. 853-857. [1906.]
3981. ——— Ueber die Bestimmung des sogenannten Pechgehaltes in Naphta, Naphtadestillaten und Rückständen durch Schwefelsäure. *Ibid.*, bd. II, pp. 99-101. [1906.]
3982. ——— Die Naphtafundstätten von Berekel. *Ibid.*, pp. 186, 186. [1906.]
3983. ——— [On Artificial Petroleum.] *Jurn. Russk. Fiz. Khim. Obsch.*, t. xxxviii, otd. 1, pp. 878-880. [1906.]
3984. ——— [Polymerization of products of Sabatier-Senderens Contact-Reaction in Artificial Petroleum.] *Ibid.*, pp. 880, 881. [1906.]
3985. ——— [Analysis of Waters from Oil-borings and Artesian Wells in the Grozni Basin.] *Ibid.*, pp. 881-883. [1906.]
3986. ——— [Inorganic Nitrogen (in Petroleum).] *Ibid.*, pp. 1275-1277. [1906.]
3987. ——— [On Extraction of Anilin Dyes from Petroleum.] *Trudi Bak. Otd. Imp. Russk. Tekhn. Obsch.*, kn. xxi, 1906.
3988. ——— [Chemistry of the Resinification of Illuminating Oil.] *Ibid.*, kn. xxii, p. 1. [1907.]
3989. ——— [Chemical Processes for Freeing Kerosene from Tar.] *Ibid.* [1907.]
3990. ——— [Various Types of Water associated with Petroleum.] *Ibid.* [1907.]
3991. ——— [On the influence of water on the Ignition-point and Viscosity of Mineral Lubricants and Petroleum Residues.] *Viestn. Jirov. Vesch.*, t. viii, p. 60. [1907.]
3992. **Kharitchkov, K. V.** [On the Oxidation-products of Kerosene and Solar Oil.] *Viestn. Jirov. Vesch.*, t. viii, p. 78. [1907.]
3993. ——— [Maumené's Method of examining Petroleum Products.] *Ibid.*, p. 131. [1907.]
3994. ——— [New Points in Petroleum Chemistry.] *Nepht. Dielo*, 1907, no. 4.
3995. ——— [Discrepancies in determination of Specific Gravity and Normal Temperature of Petroleum Products.] *Ibid.*
3996. ——— [On the Behaviour of Hydrocarbons in Presence of Alkalies.] *Ibid.* (no. 12), pp. 903-905. [1907.]
3997. ——— [On Anapa Petroleum.] *Ibid.*, no. 13. [1907.]
3998. ——— [New Asphalt Deposits, Terek.] *Tekhn. Viestn.*, 1907, kn. I, p. 74.
3999. ——— [Estimation of Sulphur in Liquid Fuels.] *Ibid.*, p. 117.
4000. ——— On a Problem relating to the Technical Uses of Petroleum. *Ibid.*, kn. II, p. 602.
4001. ——— [Application of Tchugaev's Reaction to detect Cholesterin in Fats and in Petroleum.] *Jurn. Russk. Fiz. Khim. Obsch.*, t. xxxix, otd. 1, pp. 129-131. [1907.]
4002. ——— Zwei Typen von säureartigen Oxydationsprodukten des Erdöls. *Petroleum Zeitschr.*, bd. II, pp. 480, 481. [1907.]
4003. ——— Zur Systematik der Erdölforschung. *Ibid.*, pp. 1028, 1029. [1907.]
4004. ——— [Oxidation and Resinification of Petroleum.] *Zap. Imp. Russk. Tekhn. Obsch.*, t. xli, p. 471; *Trudi Terek. Otd. I.R.T.O.*, 1909, v. 3, p. 129. [1907, 1909.]
4005. ——— [On Paraffin-manufacture in Russia.] *Tekhn. Viestn.*, 1908, kn. II, p. 107.
4006. ——— [Experiments on the Dry Distillation of Rumanian Asphalt.] *Revista Petrolului*, t. I, pp. 74, 75. [1908.]
4007. ——— [Carbonaceous Substances and Bitumens.] *Jurn. Russk. Fiz. Khim. Obsch.*, t. xli, otd. 1, pp. 1327-1334. [1908.]
4008. ——— [On Polynaphthenic Acids.] *Ibid.*, pp. 1757-1774 [1908]; t. xli, otd. 1, pp. 345-353. [1909.]
4009. ——— [On the Composition of Naphthenic Acid.] *Ibid.*, pp. 1150-1152. [1909.]
4010. ——— [Determination of Solid Paraffin in Crude Oil.] *Nepht. Dielo*, 1909, no. 14.
4011. ——— Welche Konstitution besitzen die hochsiedenden Naphtene? *Petroleum Zeitschr.*, bd. v, p. 264. [1909.]
4012. ——— Über die Säuren des Erdöls. *Ibid.*, pp. 316, 317. [1909.]
4013. ——— Ueber die Ursache der Schmierfähigkeit der Naphtafractionen. *Chem. Rev. Fett-Harz-Ind.*, bd. xvi, pp. 132, 133. [1909.]
4014. ——— Ueber paraffinhaltige Erdöle zu Grosny. *Ibid.*, pp. 247, 248. [1909.]
4015. ——— Destruktive Destillation der russischen Erdöle. *Ibid.*, bd. xvii, p. 33. [1910.]
4016. ——— Klassifikation der Erdöle und die Naphtabildenden Prozesse. *Compt. Rend. Congr. internat. Pétróle*, sess. 3, t. II, pp. 69-72. [1910.]
4017. ——— Ueber die wünschenswerte Stellung der Naphta-Chemie und Geologie in der allgemeinen Naturwissenschaft. *Ibid.*, pp. 529-531. [1910.]
4018. ——— [On the Character of the Petroleum of the Black Sea Coast and the Kuban Province.] *Gorn. Jurn.*, 1910, t. 3, pp. 225-229.
4019. ——— Zusammensetzung und Konstitution der Pech- und Asphalte. *Chem.-Zeit.*, bd. xxxiv, p. 142. [1910.]
4020. ——— Technische Destillationsprobe der Erdöle. *Ibid.*, bd. xxxv, p. 1027. [1911.]
4021. ——— Ueber einige Eigenschaften des Erdöls aus Malkop (Kubangebiet). *Allgem. österr. Chem.-Techn.-Zeit.*, bd. xxix, p. 87. [1911.]
4022. ——— [Structure of Monobasic Naphthenic Acids.] *Nepht. Dielo*, 1911, no. 9.



4023. **Kharitchkov, K. V.** [New Questions in the Technology and Chemistry of Petroleum.] *Nepht. Dielo*, 1911, no. 18.
4024. **Kharitchkov, K. V., and L. Volokhovitch.** [Fractional Precipitation of the Heavy Fractions of Petroleum by mixtures of Amylic and Ethylic Alcohols.] *Jurn. Russk. Fiz. Khim. Obsch.*, t. xxxiv, otd. 1, p. 851. [1902.]
4025. **Khatisov, K.** [Is it desirable to impose a Fire Test on Liquid Fuels?] *Zap. Imp. Russk. Tekhn. Obsch.*, xxxi, no. 11, Trudi, pp. 105-129. [1897.]
4026. ——— [Wastage of Liquid Fuel at Baku.] *Nepht. Dielo*, 1904.
4027. **Khelimski, G. G.** [New System of Oil-heating, with preliminary heating of the oil.] *Tiftsi*, 1899.
4028. **Khlopín, G. V.** [On the Nitrogen-compounds in Caucasian Petroleum.] *Jurn. Russk. Fiz. Khim. Obsch.*, t. xxxi, otd. 1, p. 8. [1899.]
4029. ——— Die organischen Basen des russischen Erdöles. *Ber. deutsch. chem. Ges.*, bd. xxxiii, pp. 2837-2841. [1900.]
- Khlopín, G. V., see Nikitin, —.**
4030. **Khodzko, —.** [Notes on Caspian Orography.] *Zap. Kavk. Otd. Imp. Russk. Geogr. Obsch.*, t. vi, p. 285. [1864.]
4031. **Khodzinski, B.** [Wieliczka.] *Gorn. Journ.*, 1891, t. 3, pp. 441-457, pl. x.
4032. **Khokhlov, M. I.** [Continuous tubular apparatus for heating and rectifying petroleum and its products.] *Trudi Bak. Otd. Imp. Russk. Tekhn. Obsch.*, 1892, pp. 32-42, pl. Report of Committee on the same, pp. 43-55. Separate report of A. P. Zimmerman and M. A. Unanov, of same Committee, pp. 56-63, pl. [1893.]
4033. **Khonin, G.** [New Isomer of Heptane.] *Jurn. Russk. Fiz. Khim. Obsch.*, t. xxxvii, otd. 1, p. 463. [1905.]
4034. **Kienlen, P.** Note sur l'essai commercial des roches et calcaires bitumineux. *Bull. Soc. Chim. Paris*, sér. 2, t. xxxiii, pp. 459-461. [1880.]
4035. **Kilham, J. T.** The Oil Wells of the United States. *Proc. Onondaga Ac. Sci.*, vol. 1, pp. 136-148. [1903.]
4036. **Killebrew, J. B.** The Oil Region of Tennessee, with some account of its other resources and capabilities. *Agric. Rep. Tenn.*, 1877, pp. 1-116. [1878.]
4037. ——— Geology and Topography of the Oil Region of Tennessee, with some account of the Oil Springs and Wells. *Proc. Amer. Assoc.*, vol. xxvi, pp. 266-276. [1878.]
4038. **Kimball, G. H.** An Operator's View of the Diesel Engine. *Power*, vol. xxxiii, p. 119. [1911.]
4039. **Kimball, J. P.** On a deposit of Grahamite, known as the Cristo Coal Mine, 100 miles south-west of the port of Tampico, Mexico. *Svo, New York*, 1876.
4040. ——— On the Occurrence of Grahamite in the Huasteca, Mexico, and Notice of the Geology of that Region. *Amer. Journ.*, ser. 3, vol. xii, pp. 277-286, wood cut. [1876.]
4041. **Kinahan, G. H.** Fossil Grease. *Athenæum*, 1883, p. 780.
4042. ——— Marsh (Natural) Gas. *Trans. Manch. Geol. Soc.*, vol. xix, pp. 121-130, 181-186. [1887.]
4043. **Kind, C. G.** Anleitung zum Abteufen der Bohrlöcher nach den neuesten und bewährtesten Erfahrungen. *Svo, Luxemburg*, 1842.
4044. ——— Description d'une methode employée près de Forbach (Moselle), pour détaches des gros échantillons dans le cours d'un sondage, et pour reconnaître la direction et l'inclinaison des couches que l'on traverse. *Ann. Mines*, t. xiii, pp. 221-225. [1848.]
4045. **Kindelan, V.** Las Minas de Azufre de Lorca. Sobre una Explosion de Grisú ocurrida en la Mina de Azufre San Juan Bautista. *Rev. Min.*, t. lvi, pp. 161-164. [1905.]
4046. **Kindle, E. M.** Salt and other Resources of the Watkins Glen Quadrangle, New York. *Bull. U.S. Geol. Surv.*, no. 260, pp. 567-572. [1905.]
4047. **King, H. S.** Report of the Department of Mines of the State of Western Australia for the year 1901. *Fo, Perth*, 1902.
4048. **King, W.** Provisional Index of the Local Distribution of Important Minerals, Gem-Stones, and Quarry Stones in the Indian Empire. *Rev. Geol. Surv. Ind.*, vol. xxii, pp. 237-286; vol. xxiii, pp. 130-203. [1889, 1890.]
4049. **Kingzett, C. T.** Some Analyses of Asphaltic Pavings. *Analyst*, vol. viii, pp. 4-8. [1883.]
4050. **Kinneir, J. M. A.** Geographical Memoir of the Persian Empire. 4to, London, 1813.
4051. **Kinney, B. A.** Report[s] of the State Supervisor of Natural Gas for the year[s] 1903-1910. *Ann. Rep. Geol. Surv. Indiana*, vol. xxviii, pp. 357-375; vol. xxix, pp. 759-770; vol. xxx, pp. 1149-1160; vol. xxxi, pp. 597-607; vol. xxxii, pp. 587-603; vol. xxxiii, pp. 385-392; vol. xxxiv, pp. 263-275; vol. xxxv, pp. 145-152. [1904-1911.]
4052. **Kirkbride, J. E.** The Boulder Oil-field, Colorado. *Eng. Min. Journ.*, vol. lxxv, p. 218. [1903.]
4053. **Kirkman, M. M.** How Oil is used for Fuel on Locomotives. *Svo, New York*, 1903.
4054. **Kirpichnikov, D.** [Salt-marshes and Oil-fields on the north-east coast of the Caspian Sea and on the R. Emba.] *Gorn. Journ.*, 1874, t. 4, pp. 259-263.
4055. **Kirwan, R.** On the Composition and Proportion of Carbon in Bitumens and Mineral Coal. 4to, Dublin, 1796.
4056. **Kissling, R.** Zur Nage der Prüfung des Leucht-petroleums durch fractionirte Destillation. *Chem. Ind.*, bd. vii, pp. 246, 247, 387-389. [1884.]
4057. ——— Zur Untersuchung von Petroleum-benzolen welche unter Gewährleistung bestimmter Siedegrenzen verkauft werden. *Chem.-Zeit.*, bd. xiv, pp. 508, 509. [1890.]
4058. ——— Das Petroleum auf der Nordwestdeutschen Gewerbe- und Industrie-Ausstellung in Bremen. *Ibid.*, pp. 1117-1119. [1890.]
4059. ——— Die Prüfung sogen. "hochtestiger" Leuchtöle (Sicherheitsöle) auf ihre Entflammbarkeit. *Ibid.*, bd. xvi, p. 1070. [1892.]
4060. ——— Neues aus dem Gebiete der Mineralöl-Industrie. *Ibid.*, pp. 1413-1415, 1599. [1892.]
4061. ——— Jahresbericht der angewandten Chemie und verwandte Gebiete. Die Erdöl-Industrie in 1892-[1910]. *Ibid.*, bd. xvii, pp. 1153, 1154; bd. xviii, pp. 1041, 1042; bd. xxi, pp. 507-510; bd. xxii, pp. 573-577; bd. xxiii, pp. 717-720; bd. xxiv, pp. 92-94; bd. xxv, pp. 486-488; bd. xxvi, pp. 490-492; bd. xxviii, pp. 541-544; bd. xxix, pp. 405-408; bd. xxx, pp. 659-662; bd. xxxi, pp. 604-606, 616-618; bd. xxxii, pp. 849, 850, 867, 868, 879, 880; bd. xxxiii, pp. 461, 462, 471, 472, 493; bd. xxxiv, pp. 961, 962, 969-972; bd. xxxv, pp. 861, 862, 879, 880. [1893-1911.]
4062. ——— Zur Untersuchung des Leuchterdöles. *Ibid.*, bd. xix, pp. 778-780. [1895.]
4063. ——— Die Prüfung des Leuchterdöles durch fractionirte Destillation. *Ibid.*, p. 1227. [1895.]
4064. ——— Die angebliche Verschlechterung des Petroleums. *Zeitschr. angew. Chem.*, bd. viii, pp. 563, 564. [1895.]
4065. ——— Zur Verbesserung der Arbeitsweise beim Gebrauche des einfachen Engler'schen Viscosimeters. *Ibid.*, bd. ix, pp. 601, 602. [1896.]
4066. ——— Die Bestimmung des Schwefelgehaltes der Verbrennungsgase des Leuchterdöles. *Chem.-Zeit.*, bd. xx, p. 199. [1896.]
4067. ——— Ueber einheitliche Untersuchungsmethoden zur Werthbestimmung der Erdölproducte. *Chem. Rev. Fett-Harz-Ind.*, bd. iii, pp. 113-122; bd. iv, pp. 7-10. [1896, 1897.]
4068. ——— Zur Frage der Einföhrung einheitlicher Untersuchungsmethoden auf dem Gebiete der Erdölindustrie. *Ibid.*, bd. iv, pp. 91, 92. [1897.]
4069. ——— Die Bestimmung des Erstarrungspunktes von Paraffinen des Handels. *Ibid.*, bd. v, pp. 87, 88. [1898.]
4070. ——— Die Wirkung des Paraffingehaltes der Leuchterdöle auf deren Leuchtermögen. *Chem.-Zeit.*, bd. xxii, pp. 223-225. [1898.]
4071. ——— Die Bestimmung des Erstarrungspunktes von Paraffinmassen und Handelsparaffin. *Chem. Rev. Fett-Harz-Ind.*, bd. viii, pp. 141, 142. [1901.]

4072. **Klissing, R.** Die Prüfung der Konsistenz von Mineral-Maschinenfetten. *Chem. Rev. Fett-Harz-Ind.*, bd. ix, p. 179. [1902.]
4073. ——— Zur Bestimmung der Viskosität von Schmierölen. *Ibid.*, pp. 202, 203. [1902.]
4074. ——— Zur Ermittlung des Flamm- und Brennpunktes von Schmierölen. *Ibid.*, pp. 223-231. [1902.]
4075. ——— Zur Bestimmung des Erstarrungspunktes von Paraffinen, Paraffinmassen und ähnlichen Stoffen. *Chem. Rev. Fett-Harz-Ind.*, bd. xi, pp. 216, 217. [1904.]
4076. ——— Die Erwärmung von Mineralölen beim Schütteln mit konzentrierter Schwefelsäure. *Chem.-Zeit.*, bd. xxix, pp. 1086, 1087. [1905.]
4077. ——— Versuche mit dem Dettmarschen Ölprüfapparat. *Ibid.*, bd. xxx, pp. 162-165, 278. [1906.]
4078. ——— Der Schwefelgehalte der Petroleumsorten des Handels. *Chem. Rev. Fett-Harz-Ind.*, bd. xiii, pp. 167, 158. [1906.]
4079. ——— Konstanten in der Mineralschmieröl-Analyse. *Chem.-Zeit.*, bd. xxx, pp. 932, 933; bd. xxxi, p. 328. [1906, 1907.]
4080. ——— Laboratoriumsbuch für die Erdöl-Industrie. *Labor.-B. Chem. Ind.*, bd. v. [1907.]
4081. ——— Zur Bestimmung des Erstarrungspunktes des Handelsparaffins. *Chem. Rev. Fett-Harz-Ind.*, bd. xv, pp. 46-49, 140. [1908.]
4082. ——— Zur Wertbestimmung der Leuchterdiöle. *Ibid.*, pp. 212-214. [1908.]
4083. ——— Das Erdöl, seine Verarbeitung und Verwendung. *Monogr. chem.-techn. Fabrik.-Methoden*, bd. xii. [1908.]
4084. ——— Neue Konstanten in der Mineralschmieröl Analyse. *Chem. Rev. Fett-Harz-Ind.*, bd. xvi, pp. 3-5. [1909.]
4085. ——— Zur Wertbestimmung des Handelsparaffins. *Ibid.*, pp. 266-268. [1909.]
4086. ——— Die Praxis der Untersuchung des Erdöles und der Erdölprodukte. *Petroleum Zeitschr.*, bd. v, pp. 505-511, 1009-1014; bd. vi, p. 245. [1910.]
4087. ——— Neue Methoden der Schmierölprüfung. *Compt. Rend. Congr. internat. Pétrole*, sess. 3, t. ii, pp. 687-690. [1910.]
4088. **Kith, D. R.** Noticia sobre el Asfalto de San Lucar de Barrameda, Cadiz. 1856.
4089. **Kitson, A.** The Kitson System of Petroleum Incandescent Light. *Trans. Midl. Inst. Min. Eng.*, vol. xvi, pp. 156-160. [1901.]
4090. ——— Petroleum Incandescent Lighting. *Journ. Soc. Arts*, vol. li, pp. 445-459. [1903.]
- Kittlberger, A. S., see Mabery, C. F.**
4091. **Klaproth, M. H.** Beiträge zur chemischen Kenntniss der Mineralkörper. 2 Bde. 8vo, Posen, 1796, 1797.
4092. ——— Examen d'un nouveau combustible fossile trouvé dans la Prusse orientale. *Mém. Ac. Roy Berlin*, sér. 2, t. v, pp. 70-78. [1803.]
4093. ——— Extracts from the Third Volume of the Analyses of M. Klaproth [Beiträge zur chemischen Kenntniss der Mineralkörper, 1803, bd. iii, not published]. *Phil. Mag.*, vol. xvii, pp. 306-310. [1804.]
4094. ——— Chemische Untersuchung eines neuen Erdharzes aus Sibirien. *Mag. Ges. Nat. Freunde Berlin*, bd. vi, pp. 74-76. [1814.]
- Klarfeld, H., see Zaloziecki, R.**
4095. **Klaudy, J.** Ueber die Werthbestimmung von Schmiermaterialien. *Compt. Rend. Congr. internat. Chim. Appl.*, sess. 3, t. iii, pp. 35-42. [1899.]
4096. ——— [New Method of Testing Lubricants.] *Naphtha*, bd. viii, 1900.
4097. ——— Die Mineralöle und verwandte Produkte im Jahre 1904-1906. *Chem. Zeitschr.*, bd. iii, pp. 821-825; bd. iv, pp. 324-328, 343-345, 364-367; bd. v, pp. 415-419, 467-471; bd. vi, pp. 70-73, 85-90. [1904-1907.]
4098. **Klaudy, J., and I. Fink.** Ueber einen neuen aromatischen Kohlenwasserstoff  $C_{21}H_{42}$  aus Erdölen. *Monatsh. Chem.*, bd. xxi, pp. 118-136. [1900.]
4099. **Klebert, A.** Entwicklung der Kanadischen Bohrkraus auf den galizischen Oelfeldern. *Naphtha*, bd. xv, pp. 434-438, 445-450, 494-498. [1907.]
4100. **Kleinschmidt, J. L.** [Petroleum in America and Galicia.] *Rev. Univ. Mines*, t. xxii, pp. 435-438. [1867.]
4101. ——— Notizen über Petroleum. *Berg-Hütt. Zeit.*, bd. xxvi, pp. 62, 63. [1867.]
4102. ——— Asphaltlagerstätten und Kohlenbildung. *Ibid.*, bd. xlvii, pp. 78-81, section. [1887.]
4103. **Kleist, W. v.** Die Petroleum-Industrie in Oelheim. 8vo, Dresden, 1882.
4104. **Klement, C.** Les théories relatives à l'origine du pétrole. *Bull. Soc. Belge Géol.*, t. xi, Proc.-Verb., pp. 76-85. [1897.]
4105. **Klemm G.** Ueber zwei Bohrungen der geologischer Landesanstalt bei Heppenheim a. d. Bergstrasse. *Notizbl. Ver. Erdk. Darmstadt*, ser. 4, bd. xxv, pp. 3-9. [1904.]
4106. **Kletzinski, V.** Ueber die Erzeugung der Feuerfarben hinsichtlich des quantitativen Ertrages und über neue Läuterungsmethoden des Rohparaffins. *Polyt. Journ.*, bd. cixxiii, pp. 472-474. [1864.]
4107. ——— Purification de la paraffine. *Journ. Eclair. Gaz.*, ann. xix, p. 105. [1871.]
4108. **Klimin, —.** [Petroleum in the Idokan Hills, Tiflis.] *Nephth. Dielo*, 1909, no. 18, pp. 14-18.
4109. **Klimont, J.** Eine neue Methode zur Bestimmung von Harzöl in Mineralöl. *Chem. Rev. Fett-Harz-Ind.*, bd. i, no. 10, pp. 4, b. [1895.]
4110. ——— Anforderungen, welche an ein Benzin zur Grubenbeleuchtung zu stellen sind. *Ibid.*, no. 14, pp. 2, 3. [1895.]
4111. ——— Präcisirung der Constanten und Zahlen für die Produkte der Fett- und Mineralölindustrie. *Compt. Rend. Congr. internat. Chim. appl.*, sess. 3, t. i, pp. 253-256. [1899.]
4112. **Klinkowström, J. C. v.** Beiträge zur Geschichte des Petroleum. XI. Die ersten Nachrichten über das Erdöl und die ewigen Feuer in Baku. XII. Kirchers Rohrleitung für Petroleum von 1665. *Petroleum Zeitschr.*, bd. vi, pp. 1053-1056, 2244. [1911.]
4113. **Klinge, G.** Estadística Minera del Peru en 1906. *Bol. Ing. Minas, Peru*, no. 64. Pp. 39, 2 pls. [1907.]
4114. **Klisiče de la Grange, A.** Sulla formazione di alcuni vulcanetti di fango nei dintorni di Civitavecchia. *Rome*, 1880.
4115. **Klitke, M.** Die Naturgasgebiete von Ohio und Indiana. *Zeitschr. prakt. Geol.*, bd. ii, pp. 272-279. [1894.]
4116. **Klitzsch, G.** Ueber das Vorkommen, die Eigenschaften und die Entstehung des Petroleum. 4to, 1887.
4117. **Klochmann, —.** Lehrbuch der Mineralogie. 1892.
4118. **Kloppen, —.** [Effect of Petroleum on Fisheries of the Volga.] *Petrol. Rev.*, vol. i, p. 178. [1899.]
4119. **Klose, —.** Das Selbbohren in Nordamerika. *Zeitschr. Berg-Hütt.-Salinenw.*, bd. xliii, pp. 347-356; pls. xxi, xxii. [1894.]
4120. **Kluge, F.** Zur Köhlein'schen Darstellung der Paraffine. *Ann. Chem. Pharm.*, bd. cclxxxii, pp. 214-228. [1894.]
4121. **Kluk, C.** [Economic Minerals.] *Warsaw*, 1797.
4122. **Knab, Ch.** Théorie de la Formation de l'Asphalte au Val de Travers et de la Production des Bitumes Volatils en général. *Bull. Soc. Sci. Nat. Neuchâtel*, t. viii, pp. 226-238. [1869.]
4123. ——— Notice sur l'emploi des combustibles de l'huile minérale pour le chauffage des navires à vapeur, et sur l'application de l'oxygène à la combustion. *Ann. Gén. Civil*, t. vii, pp. 305-321. [1868.]
4124. **Knapp, G.** Les secrets de fabrication des Moteurs à essence pour Motocycles et Automobiles. 8vo, Troyes, 1899.
- Kneiss, E., see Engler, C.**

4126. **Knepper**, — Die Entwicklung der deutscher Erdölindustrie sowie ihre wirtschaftliche Bedeutung und Steigerung der rapiden Förderung der letzten Jahre. *Bergbau*, 1911, pp. 484, 485, 498-500.
4126. **Kner**, R. Kleine Beiträge zur weiteren Kenntniss der geognostischen Verhältnisse Istriens. *Jahrb. k.-k. Geol. Reichs.*, bd. iv, pp. 223-232. [1853.]
4127. **Knight, C. W.** Oil and Gas in Kent County, Ontario. *Ann. Rep. Bureau Mines Ontario*, vol. xvi, pt. 1, pp. 92-104. [1907.]
4128. **Knight, J. H.** Light Oil Motors. *Automotor Journ.*, vol. ii, pp. 367, 368. [1898.]
4129. — Paraffin Oil v. Petrol. *Car Illustrated*, Jan., 1907.
4130. **Knight, W. C.** Notes on the Mineral Resources of Wyoming. *Wyoming Experiment Station Bulletin*, no. 14, pp. 119-212. [1893.]
4131. — Notes on the Mineral Resources of Wyoming. *School of Mines, Univ. Wyo., Bulletin*, no. 1, pp. 112. [1893.]
4132. — The Geology and Technology of the Salt Creek Oil-Field. *Ibid.*, *Petroleum Series*, no. 1, pp. 1-22, 6 pls. [1896.]
4133. — The Petroleum Fields of Wyoming. *Ann. Rep. U.S. Geol. Survey*, vol. xvii, pt. iii, pp. 702-707. [1896.]
4134. — The Geology of the Popo Agle, Lander and Shoshone Oil-Fields. *School of Mines Univ. Wyo., Bulletin, Petroleum Series*, no. 2, pp. 1-20, map, 2 sections, 2 views. [1897.]
4135. — The Petroleum Fields of Wyoming. *Eng. Min. Journ.*, vol. lxxii, pp. 358, 359, 628-630, 720-722. [1901, 1902.]
4136. **Knight, W. C.**, and **E. E. Slosson**. The Oil-Fields of Crook and Uinta Counties, Wyoming. *School of Mines Univ. Wyo., Bulletin, Petroleum Series*, no. 3. P. 31, 2 maps. [1897.]
4137. —, —, The Dutton, Rattlesnake, Arago, Oil Mountain and Powder River Oil Fields. *Ibid.*, no. 4. P. 57, map. [1901.]
4138. —, —, The Newcastle Oil Field. *Ibid.*, no. 5. [1902.]
4139. —, —, The Bonanza, Cottonwood and Douglas Oil-fields. *Ibid.*, no. 6. P. 30. [1903.]
4140. **Knirk, C. F.** Natural Gas in the Glacial Drift of Champaign County. *Bull. Geol. Surv. Illinois*, no. 14, pp. 272-275. [1909.]
4141. **Knop, A.** Ueber das Vorkommen von Petroleum bei Reichartshausen im Odenwald. *N. Jahrb.*, 1873, pp. 529-533.
4142. **Knop, W.** Ueber Anwendung des Broms zum Bromiren organischer Substanzen nach quantitativ bestimmbarer Verhältnissen, und eine maassanalytische Prüfungs methode für Fette und flüchtige Ole. *Pharm. Centr.*, bd. xxv, pp. 320-323, 403-414. [1854.]
4143. **Knox, G.** Experiments and Observations on the Newry Pitchstone and its Products, and on the formation of pumice. *Phil. Trans.*, 1822, pp. 313-338.
4144. — On Bitumen in Stones. *Ibid.*, 1823, pp. 517-525.
4145. **Knox, S. G.** Report on the Trade of Muscat for the years 1910-11. *Dipl. Cons. Rep. ann. ser.*, no. 4822. [1911.]
4146. **Koaniet, P.** [Remarks on the covering of Casemate Vanits with Seyssel Asphalt executed in 1833 and following years in the Vensen Fortress.] *Warsaw*, 1877.
4147. **Kobbe, W. H.** Use of Concrete Foundations for Derricks. *Oil Age*, March 3, 1911.
4148. **Kobell, F. v.** Ueber das Erdöl von Tegernsee im Baiserische Oberlande. *Abh. k.-bayr. Ak. Wiss. Münch.*, 1831-1836, th. 2, pp. 141-161.
4149. — [Paraffin in Tegernsee Petroleum.] *Journ. prakt. Chem.*, bd. v, p. 213. [1835.]
4150. **Koch, A.** [Critical Review of Transylvanian Minerals.] *Orvos-termesz. Ertes.*, 1885.
4151. — [Mineralogical Notes from Transylvania.] *Ibid.*, 1890.
4152. **Koch, A.** Die Tertiarbildungen des Beckens des Siebenbürgischen Landestheile. *Mitt. Jahrb. k. ung. geol. Anst.*, bd. x, pp. 191-397, pls. v-lx. [1894.]
4153. **Koch, F.** [Geological Notes on the Moslavine Hills.] *Rud. Jugoslav. Akad.*, 1899.
4154. **Koch, G. A.** Die im Schlier der Stadt Wels erbohrten Gasquellen, nebst einigen Bemerkungen über die obere Grenze des Schliers. *Verh. k.-k. geol. Reichs.*, 1892, pp. 183-192.
4155. — Neue Tiefbohrungen auf brennbare Gase im Schlier von Wels, Grieskirchen und Eferding in Oberösterreich. *Ibid.*, 1893, pp. 101-129.
4156. — Die Naturgase der Erde und die Tiefbohrungen im Schlier von Oberösterreichs. *Monatsbl. Wiss. Clubs, Wien*, bd. iv, pp. 42, pl. [1893.]
4157. — Geologisches Gutachten über die anlässlich der commissionellen Erhebungen am 28 Jänner 1895 beobachteten und auch schon früher wahrgenommenen Gasausströmung in der Schottergrube der k. k. Staatsbahnen zu Wels. *Wels*, 1895.
4158. — Geologisches Gutachten über das Vorkommen von brennbaren Natur- oder Erdgasen, jod- und bromhaltigen Salzwässern, sowie Petroleum und verwandten Mineralprodukten im Gebiete von Wels und in Oberösterreich. *Vienna*, 1902.
4159. — Das Welsler Erdgas und dessen rationellere Verwertung. *Allgem. österr. Chem.-Techn.-Zts.*, bd. xxix, pp. 17-21. [1911.]
4160. **Kochibe, T.** Outlines of the Geology of Japan. *8vo, Tokyo*, 1902.
4161. **Kochibe, T.**, and **E. Sagawa**. Imperial Geological Survey of Japan. Oil-Fields of Japan. Section 1. Higashiyana Oil-Field, Echigo. *8vo, Tokyo*, 1902.
- Köchlin-Schlumberger, J.**, see **Delbos, J.**
4162. **Köhler, H.** Die Chemie und Technologie der natürlichen und künstlichen Asphalte. Ein Handbuch der gesamten Asphalt-Industrie für Fabrikanten, Chemiker, Techniker, Architekten und Ingenieure. *8vo, Brunswick*, 1904.
4163. — Beitrag zum Nachweis von Verfälschungen im Naturasphalt. *Chem.-Zeit.*, bd. xxx, pp. 36, 37, 673-678. [1906.]
4164. **Köhnlein, B.** Eine bequeme Darstellung der Paraffine. *Ber. deutsch. chem. Ges.*, bd. xvi, pp. 560-563. [1883.]
4165. **Könen, A. v.** [North German Petroleum.] *Zeitschr. deutsch. geol. Ges.*, bd. xxxvi, pp. 691-693. [1884.]
4166. — Ueber die Ergebnisse der Aufnahmen im Jahre 1899. *Jahrb. k. preuss. geol. Landesanst.*, bd. xx, pp. 13-20. [1900.]
4167. **König, G. A.**, and **M. Stockder**. On the Occurrence of Lustrous Coal with Native Silver in a Vein in Porphyry, in Ouray County, Colo. *Trans. Amer. Inst. Min. Eng.*, vol. lx, pp. 650-656. [1881.]
4168. **Königsberger, J.**, and **M. Muhlberg**. On Measurements of the Increase of Temperature in Boreholes; with the Depth, the Technics, and Practical Importance of the same for Geological Prognosis, with reference to new Measurements in Mexico, Borneo, and in Central Europe. *Trans. Inst. Min. Eng.*, vol. xxxix, pp. 617-644. [1910.]
4169. **Könlein**, —, [Mineral or Native Naphthaline. *Verh. 13 Versamml. Schweiz. Ges. Nat.*, 1827.
4170. **Könyöki**, —, Ueber das Erdwachs. *Verh. Ver. N. Heilk. Pressburg*, 1881-83, pp. 153-160. [1883.]
4171. **Kört**, —, Geologisches von der Erdgasquelle bei Nenengamme. *Petroleum Zeitschr.*, bd. vi, p. 321. [1910.]
4172. **Köster, F.** The Production and Use of Electricity in a Russian Petroleum Field. *Electr. Rev.*, vol. xivi, pp. 846, 847. [1905.]
4173. **Kogan, R. L.** [Asphalt, its properties and uses.] *Zap. Odessk. Otd. Imp. Russk. Tekhn. Obsch.*, Jan.-Feb. 1887, pp. 46-72.
4174. **Kohlmoorgen, M.** Berg- und hüttenmännischen Mittheilungen über die Provinz Tarma in Peru. *Zeitschr. Berg-, Hütten- u. Salinenw.*, bd. xxxviii, 502-517. [1890.]

4175. **Koldevin**, —. [Asphalt and Klr. and the Narudja Asphalt-rock.] *Zap. Kavk. Otd. Imp. Russk. Tekhn. Obsch.*, g. xvii, otd. ii, pp. 1-9. [1885.]
4176. **Kolenati, F. A.** Die Mineralien Mährens und Oesterreichisch-Schlesiens, deren Fundorte und ökonomisch-technische Verwendung. Ein Hilfsbuch. . . . 8vo, Brünn, 1854.
4177. **Kollen, T.** Petroleum als Mittel zur Insektenvertilgung. *Bayr. Gewerbe Zeit.*, 1868.
4178. — Ueber das Vermögen des Petroleums, Yod und Schwefel aufzulösen. *Polyt. Journ.*, bd. cxlxi, p. 509. [1869.]
4179. **Koller, G.** The Chlorine Derivatives of Ethane and Ethylene and their Industrial Importance as Non-Inflammable, Non-Combustible, and Non-Explosive Solvents. *Compt. Rend. Congr. internat. Chim. appl.*, sess. 7, sect. iv, pp. 19-22. [1910.]
4180. **Kollmann**, —. Neue Petroleumbohrungen in Deutschland. *Wochenschr. Ver. deutsch. Ing.*, 1883, pp. 20, 21.
4181. **Kondakov, I.** [Action of Anhydrous Acids on Olefines in presence of Zinc Chloride.] *Jurn. Russk. Fiz. Khim. Obsch.*, t. xxvi, otd. i, pp. 229-234. [1894.]
4182. **Konek, F. v.** Schwefelbestimmungsverfahren "Rapid," eine neue expeditiv und einfache quantitative Methode zur Ermitteln des Schwefelgehalte in Kohlen, Erdölen, Bitumen und ähnlichen Körpern, sowie in organischen Verbindungen überhaupt. *Compt. Rend. Congr. internat. Chim. appl.*, sess. 5, t. 1, pp. 360-368. [1904.]
4183. **Konovalov, D.** Ueber die Dampfspannungen der Flüssigkeitsgemische. *Ann. Phys. Chem.*, f. 2, bd. xiv, pp. 34-52, 219-226. [1881.]
4184. **Konovalov, M. I.** Nitration des hydrocarbures de la série du méthane. *Compt. Rend.*, t. cxiv, pp. 26-28. [1892.]
4185. — [Nitrating Action of Nitric Acid on Saturated Hydrocarbons.] *Jurn. Russk. Fiz. Khim. Obsch.*, t. xxv, otd. i, pp. 389-425, 472-500, 509-546; t. xxvi, otd. i, pp. 380-402. [1893, 1894.]
4186. — [New Isomer of Heptane, symmetric tetramethylpropane.] *Jurn. Russk. Fiz. Khim. Obsch.*, t. xxvii, otd. i, pp. 910, 911. [1905.]
4187. **Konovalov, M. I.**, and **A. Plotnikov**. [Composition of Grozni Naptha.] *Jurn. Russk. Fiz. Khim. Obsch.*, t. xxxiii, pp. 50, 51. [1901.]
- Konovalov, M. I.**, see **Markovnikov, V.**
4188. **Konschin, A. M.** [Petroleum and Ozokerite Deposits in the Transcasplian Province.] *Gorn. Journ.*, 1883, t. 1, pp. 143-150, map.
4189. — [Sarikamisch Lake Basin and the Western Uzbol River.] *Izv. Imp. Russk. Geogr. Obsch.*, t. xxi, pp. 202-218. [1886.]
4190. — [Geology and Geography of Transcasplia.] *Izv. Kavk. Otd. Imp. Geogr. Obsch.*, t. ix, pp. 149-196. [1887.]
4191. — [Report upon the Oil-fields of the Trans-Kuban Province and the Taman Peninsula.] *Mat. Geol. Kavk.*, ser. 2, kn. ii, pp. 79-240, 2 pls. [1883.]
4192. — [Useful Minerals of Transcasplia.] *Verh. russ. k. Min. Ges.*, bd. xxiv, pp. 23-35. [1888.]
4193. — [Description of the Isk Naptha Deposit, Kuban.] *Mat. Geol. Kavk.*, ser. 2, t. iv, pp. 90-108, map, 2 pls. [1890.]
4194. — [Structure of the Balakhanli-Sabuntchi-Romani Oil-field.] *Ibid.*, pp. 248-266, map and sections. [1890.]
4195. — [Geological Description of the Grozni Oil-field and the Oil Deposits of the Terek Province and Caspian Littoral.] *Ibid.*, kn. vi, pp. 161-288, 2 maps, 1 pl., sections. [1892.]
4196. — [Geological Structure of the Balakhanli-Sabuntchi-Romani-Zatrat Oil-field, and its contents.] *Ibid.*, kn. viii, pp. 1-109, map and sections. [1894.]
4197. — [Description of the Operations on the Oil-fields of North America, and Comparative Condition of Oil Yield in the Caucasus.] 8vo, Tiflis, 1896.
4198. **Konschin, A. M.** De Wladikavkaz aux Gisements de Naphte de Grosny. *Guide vit Congrès géol. internat.*, 1897, no. 18, p. 4, figs.
4199. — De Tiflis à Bakou. Gisements de Naphte de Bakou. *Ibid.*, no. 24, pp. 1-5, figs.
4200. — [Investigation of the Northern Part of the Black-Sea Coast.] *Mat. Geol. Kavk.*, ser. 2, t. x, pp. 175-359, map. [1897.]
4201. **Konstantinov**, —. [Baku Fires and Hindu Fire-worship.] *Russk. Khudoj. Listok*, 1861, no. 24.
4202. **Kontkiewitch, S.** Geologische Untersuchungen im südwestlichen Theile vom Königreich Polen. *Verh. k.-k. geol. Reichs.*, 1881, pp. 66-69.
4203. — [Geological Investigations in 1880 in the Southern Part of the Kielets Government, Poland.] *Pamiatnik Fizyogr.*, t. ii, pp. 175-203. [1882.]
- Kopp, C.**, see **Hessel, J. F. C.**
4204. **Kopp, E.** Sur les Huiles Minérales naturelles et spécialement celles d'Amérique. *Rép. Chim. Appl.*, 1862, pp. 408-417.
4205. — Sur la Composition et la Constitution des Huiles Minérales artificielles et naturelles. *Monit. Scient.*, t. v, pp. 570-575, 612-617. [1863.]
4206. — Sur l'antracène et ses dérivés. *Ibid.*, t. xiii, pp. 531-542, 691-698; t. xiv, pp. 33-43, 252-260, 319-327, 681-688; t. xv, pp. 14-21. [1871-1873.]
4207. **Kopp, H.** [Gas Springs in the River Donb near Brenets.] *Bull. Soc. Sci. Nat. Neuchâtel*, t. iv, pp. 312-318. [1858.]
4208. — Ueber die Siedepuncte der Kohlenwasserstoffe  $C_nH_{2n-6}$ . *Ann. Chem. Pharm.*, bd. lxxxi, pp. 815-828. [1867.]
4209. **Kordynsk, —**, and — **Didkovski**. [Oil and its Products.] *Tekhn. Sborn.*, t. xviii, pp. 348, 365.
- Koriander, E. V.**, see **Lisenko, K. I.**
4210. **Korjenski, S.** [On the Question of the Treatment of Phthisis by Petroleum.] *Vratch*, 1887, p. 350.
4211. **Korski, J.** Kilometerschächte in Boryslaw. *Naphta*, bd. xii, pp. 196, 197, 209-212. [1904.]
4212. **Korzukhin, I.** Maikop Petroleum. *Torg.-Prom. Gaz.*, 1910, nos. 128, 129.
4213. **Koschul, F. v.** [Oil Resources of the Caucasus.] *Gorn. Journ.*, 1865, t. 3, p. 8.
4214. — [Oil-fields of the Trans-Kuban Province and Taman Peninsula.] *Ibid.*, 1865, t. 3, pp. 73-93, 195-200.
4215. — Notes on the Caucasus. *Amer. Journ.*, ser. 2, vol. xvi, pp. 214-221, 335-347. [1868.]
4216. — [Geological Operations on Tcheleken I.] *Zap. Kavk. Otd. Russk. Tekhn. Obsch.*, g. li, p. 194. [1870.]
4217. — [Statistical Tables of the Petroleum Trade of Apsheron to 1862.] *Ibid.*, g. vi, pp. 154-162. [1874.]
4218. — Ueber die russische Naphta-produktion und Photogenfabrikation in den Jahren 1874 und 1875. *Zeitschr. Paraff. Ind.*, 1877, p. 23.
4219. — Vorkommen von Ozokerit im Kaukasus. *Ibid.*, p. 73.
4220. — [Geological Researches on the Terek and Kabardin-Sunien Ranges, and the Alkhantchurt Valley between them.] *Gorn. Journ.*, 1879, t. 3, pp. 170-204.
- Koschul, F. v.**, see **Neschel**, —.
4221. **Koss, A. K.** [Presence of Cholesterol in Java Petroleum.] *Jurn. Russk. Fiz. Khim. Obsch.*, t. xliii, otd. i, pp. 697-707. [1911.]
4222. — [Analysis of Boryslaw Ozokerite.] *Ibid.*, pp. 846-855. [1911.]
4223. **Kosmat, F.** Bemerkungen über die Ammoniten ans der Asphalt-schiefer der Barabai (Burru). *N. Jahrb.*, beil. bd. xxii, pp. 686-691. [1906.]
4224. **Kotikov, M.** [Preservation of Steel Cannon from Rust.] *Zap. Imp. Russk. Tekhn. Obsch.*, g. liii, otd. 4, pp. 21-31. [1869.]
4225. — [Mineral Oil as a Means of Preserving Weapons from Rust.] *Morsk. Sborn.*, 1878, p. 78.
4226. **Koundjy, P.** Le Bitume de Naphte. *Bull. Soc. Encour.*, t. xciv, pp. 1116-1119. [1895.]

4227. **Kovacs, J.** Ueber Asphalt, sein Vorkommen, seine Verwendung und übereinschlägige Untersuchungen. 8vo, Budapest, 1901.
4228. **Kovacs, J.**, and **S. Sötét.** Analytisches Verfahren zur Unterscheidung des natürlichen Asphalt-bitumens von Petroleumpech (Naphthasatz) oder sogenannten Petroleumasphalt und von Steinkohlenteerpech. *Chem. Rev. Fett-Harz-Ind.*, bd. vii, pp. 8-10. [1900.]
4229. **Kowalewski, V. O.** [On the Means of Simplifying and Expanding the Petroleum Industry of Russia.] *St. Petersburg*, 1881.
4230. **Krämer, G.** Ueber das Wesen, den Ursprung und die Entstehung des Erdöls. *Sitz. Ver. Beförd. Gewerbf.*, 1885, pp. 288-313.
4231. — Ueber die Entstehung des Erdöls. *Ber. 71 Vers. Ges. deutsch. Naturf. Aersie*, 1899.
4232. — Das Erdöl und seine Beziehungen zum Pflanzenreich. *Sitz. Ver. Beförd. Gewerbf.*, 1902, pp. 93-103.
4233. — Zur Frage der Petroleum- und Mineralölverzollung. *Chem. Ind.*, bd. xxvi, pp. 445-451. [1903.]
4234. — Beitrag zur Frage der Erdölbildung. *Chem.-Zeit.*, bd. xxxi, pp. 675-677. [1907.]
4235. — Der Crackingprozess bei der Verarbeitung rimänischen Erdöls. *Petroleum Zeitschr.*, bd. iii, pp. 894, 895. [1908.]
4236. **Krämer, G.**, and **W. Böttcher.** Ueber die deutschen Rohpetrole, deren Untersuchung und Verarbeitung. *Verh. Ver. Beförd. Gewerb. Preuss.*, bd. lxvi, pp. 549-572. [1887.]
4237. — Ueber die Beziehungen des Erdöls zu den Kohlenwasserstoffen der Braun- und Steinkohlenteeröls. *Ber. deutsch. chem. Ges.*, bd. xx, pp. 595-609. [1887.]
4238. **Krämer, G.**, and **C. Sarnow.** Verfahren zur Bestimmung des Schmelzpunkts von Pech, Asphalt und ähnlichen Stoffen. *Chem. Ind.*, bd. xxvi, pp. 55-57. [1903.]
4239. **Krämer, G.**, and **A. Spilker.** Ueber künstliche Mineralölschmieröle, die Condensationsproducte des Allylalkohols mit den methylirten Benzölen. *Ber. deutsch. chem. Ges.*, bd. xxiv, pp. 2785-2793. [1891.]
4240. — Der Wachs der Bacillariaceen und sein Zusammenhang mit dem Erdöl. *Ibid.*, bd. xxxii, pp. 2940-2959. [1900.]
4241. — Ueber die Zersetzung viscöser Körper (Schmieröle) durch Destillation unter Druck. *Ibid.*, bd. xxxiii, pp. 2265-2270. [1900.]
4242. — Das Algenwachs und sein Zusammenhang mit dem Erdöl. *Ibid.*, bd. xxxv, pp. 1212-1223. [1902.]
4243. **Krätzer, H.** Die Fabrikation der deutschen, französischen und englischen Wagenfette. 8vo, Vienna, 1888.
- Krafft, —**, see **Tsulukidze, K.**
4244. **Krafft, F.** Ueber neunzehn höhere Normalparaffine  $C_{10}H_{22}$  und ein einfaches Volumesatz für den tropfbarflüssigen Zustand. *Ber. deutsch. chem. Ges.*, bd. xv, pp. 1687-1727; bd. xix, pp. 2218-2233. [1882, 1886.]
4245. — Zur Darstellung höherer Olefine, insbesondere über Dodecylein  $C_{12}H_{24}$ , Tetradecylein  $C_{14}H_{28}$ , Ceten und Hexadecylein  $C_{16}H_{32}$  und Octadecylein  $C_{18}H_{36}$ . *Ibid.*, bd. xvi, pp. 3018-3024. [1883.]
4246. — Ueber Identität der Braunkohlenparaffine mit den künstlichen Normalparaffinen. *Chem. Zeit.*, jg. vii, p. 154. [1883.]
4247. — Ueber einige höhere Acetylenhomologe und den Erstarrungspunkt als Vergleichs-temperatur. *Ber. deutsch. chem. Ges.*, bd. xvii, pp. 1371-1377. [1884.]
4248. — Ueber Isolirung der höheren Normalparaffine aus Braunkohlenparaffin. *Ibid.*, bd. xxi, pp. 2250-2265. [1888.]
4249. — Ueber Vacuumdestillation und einige Regelmäßigkeiten, welchen die in luftleeren Räumen erzeugten Flüssigkeiten und Dämpfe gehorchen. *Ibid.*, bd. xxxii, pp. 1623-1655. [1899.]
4250. **Krafft, F.** Ueber fraktionirte Destillation der höheren Normalparaffine aus Braunkohle in Vacuum des Kathodensichts. *Ber. deutsch. chem. Ges.*, bd. xi, pp. 4779-4784. [1907.]
4251. **Krafft, F.**, and **H. Weilandt.** Siedetemperaturen beim Vacuum des Kathodensichts. *Ibid.*, bd. xxix, pp. 1316-1328, 2240-2245. [1896.]
4252. **Krajenski, F.** Ueber die Herstellung weisser Vaselineöle. *Seifen- und Zeit.*, bd. xxxviii, pp. 539, 581. [1911.]
4253. **Krawow, —**. [Oil-gas from Lignite.] *Rheinl. Westphal. Gas-Wasser-Ing.*, 1884.
4254. **Kramarevsky, M.** [Analysis of the Mud of the Bulganak Volcano, Kertch.] *Izv. Varsavsk. Univ.*, 1886, pp. 1-5.
4255. **Krasnopolski, A.** [Discovery of Petroleum near Sterlitamak, Ufa.] *Bull. Com. géol. Russ.*, t. xxi, Juro., pp. 21-27. [1902.]
4256. **Kraus, E.** Ueber den Scheererit von Utznach. *Ann. Phys. Chem.*, bd. xliii, pp. 141-147. [1838.]
4257. **Krause, —**. [Khokand Oil-springs.] *Izv. Mosk. Obsch. Lyub. Estest.*, 1870-1871.
4258. **Krauz, C.** Beitrag zur Schulz'schen Farbenreaktion der Mineralöle. *Chem.-Zeit.*, bd. xxxii, p. 409. [1909.]
4259. **Kraynax, A. v.** [Analysis of Asphaltic Slates and Limestones of Seefeld, Tyrol.] *Jahrb. k.-k. geol. Reichs.*, bd. vii, p. 372. [1856.]
4260. **Krcarik, D. P.** [The Schemakha Earthquake, 1902.]
4261. **Krejci, J.**, and **R. Helmhacker.** Erläuterungen zur geologischen Karte der Umgebungen von Prag. *Arch. Nat. Land. Böhm.*, bd. iv, no. 2, p. 247, map. [1879.]
4262. **Kremers, P.** Ueber die Aschenbestandtheile und die Producte der trocknen Destillation bei Braun- und Steinkohlen. *Ann. Phys. Chem.*, bd. clx, pp. 67-77. [1851.]
4263. — De Relatione inter Carbores fuscus atque nigros. *Berlin*, 1851.
- Krepelka, V.**, see **Lunge, G.**
4264. **Kreutz, Felix.** Ueber den Ursprung des Erdöls in der galizischen Salzformation. *Verh. k.-k. geol. Reichs.*, 1881, pp. 28-33.
4265. — Erklärung zu Dr. Tietze's "Bemerkungen zu den Ansichten von F. Kreutz über das Erdöl der galizischen Salzformation." *Ibid.*, pp. 101-103.
4266. — Ueber die Bildung und Umbildung von Erdwachs und Erdöl in Galizien. *Ibid.*, pp. 113-119, 182, 183.
4267. — Beitrag zur Erklärung des Ozokerit- und Naphtha-Vorkommens in Galizien. *Ibid.*, pp. 311-314.
4268. **Kreutz, F.**, and **R. Zuber.** [Geology of Mraznica and Schodnica Districts.] *Kosmos*, t. vi, pp. 317-341, map and sections. [1881.]
4269. **Krey, —**. Oelgasindustrie. *Zeitschr. angew. Chem.*, bd. viii, pp. 282-284. [1895.]
4270. — Ueber Mineralöl und Paraffinindustrie. *Ibid.*, bd. ix, pp. 374-380. [1896.]
4271. **Krivoshchapina, G. de.** Applications du pétrole à la métallurgie et à l'industrie du verre. *Gén. Côté*, t. xxxvii, pp. 309-311. [1900.]
4272. **Kröker, K.** Ueber die Bestimmung der nutzbaren Verbrennungswärme der Heizmaterialien. *Zeitschr. Ver. Rübenv. Ind.*, bd. xlvi, pp. 177-194. [1896.]
4273. — Die Elementaranalyse in der Berthelot'schen Bombe. *Ber. deutsch. chem. Ges.*, bd. xxx, pp. 605-607. [1897.]
4274. **Kromer, N.** [Masut.] *Zeitschr. anal. Chem.*, bd. xxxvii, pp. 176-181. [1898.]
- Kropf, A. H.**, see **Shermaa, H. C.**
4275. **Krüger, R.** Die Lehre von den Brennmaterialien. Beschreibung der chemischen Zusammensetzung, Gewinnung und Fabrikation aller natürlichen und künstlichen, fester, flüssigen und gasförmigen Brennstoffe. 8vo, Jena, 1883.
4276. **Krupski, A. K.** [Petroleum.] *Jurn. Russk. Fiz. Khim. Obsch.*, t. vii, otd. 2, pp. 67-96, 130-146, 174-212. [1875.]

4277. **Krupski, A. K.** [On Petroleum Illuminant Gas.] *Zap. Imp. Russk. Tekhn. Obsch.*, g. x, otd. 1, pp. 177-193. [1876.]
4278. **Kruseh, P.** Uebersicht über die nutzbaren Lagerstätten Russlands. *Zeitschr. prakt. Geol.*, bd. v, pp. 272-286. [1897.]
4279. **Krusenstern, A. F.** [New Method of Carburetting Air with Petroleum, and Uses of the Gas so produced.] *Zap. Imp. Russk. Tekhn. Obsch.*, g. xxxvi, Trudi, pp. 375-386. [1902.]
4280. **Krzeczowski, E. R. de.** Notes sur l'île Tchelenk. *Journ. Pétrole*, t. ii, pp. 17, 18. [1902.]
4281. ——— Pirlaggi (Erdölfeld). *Org. Ver. Bohrtechn.*, bd. xvii, pp. 14-16. [1910.]
4282. **Kuckla, F. F.** Zur Prüfung der Petroleums. *Wochen-schr. niederöstrerr. Gewerbever.*, 1866, p. 782.
4283. **Kudelin, G. P.**, see **Popov, P. I.**
4283. **Kudisch, D.** [Commercial Kerosenes from Kiev.] *Journ. Russk. Fiz.-Khim. Obsch.*, t. xxxiv, otd. 1, pp. 201, 202. [1902.]
4284. **Küchler, F. N.** Handbuch der Mineralöl-Gas-belenchtung und der Gasbereitungs-öle. 4to, *Munich*, 1878.
4285. **Künkler, A.** Zur Kenntniss der Mineralmaschin-öle. *Polyt. Journ.*, bd. cclxxiv, pp. 276-284. [1889.]
4286. ——— Prüfung der Mineralmaschinenöle auf Kältebeständigkeit. *Ibid.*, bd. cclxxix, pp. 137-139. [1891.]
4287. ——— Viscosimeter für Maschinenschmieröle. *Ibid.*, bd. ccxc, pp. 281-283. [1893.]
4288. ——— Die Maschinenschmierung, die Schmiermittel und ihre Untersuchung. *Mannheim*, 1894.
4289. ——— Ueber Flamm- und Brennpunktsbestimmungen von Mineralschmierölen. *Chem.-Zeit.*, bd. xxiii, pp. 166-169. [1899.]
4290. ——— Die Werthbestimmung der Schmiermittel. *Compt. Rend. Congr. internat. Chim. appl.*, sess. 3. t. i, pp. 120-131. [1899.]
4291. ——— Die Bildung von Erdöl (Mineralölen, Paraffin, etc.) aus Oel- und Fettsubstanz bei gewöhnlichem Druck. *Seifensied.-Zeit.*, bd. xxxvii, p. 291. [1910.]
4292. **Künkler, A.**, and **H. Schwedhelm.** Die Bildung von Erdöl (Ceresin, Paraffin, viskosen und leichten Mineralölen, Asphalt) aus fettsauren Erdalkalien. *Seifensied.-Zeit.*, bd. xxxv, pp. 1285, 1286, 1341, 1342, 1365, 1366, 1393, 1394. [1908.]
4293. **Künkler, A.**, see **Engler, C.**; and **Kast, H.**
4293. **Kuhn.** ——— Ueber Beleuchtung in Vergangenheit und Gegenwart. 8vo, *Leipzig*, 1908.
4294. **Kuklin.** ——— [Combustibility and Latent Heat of Evaporation of some Products of Fractional Distillation of Petroleum.] *Journ. Russk. Fiz. Khim. Obsch.*, t. xv, otd. 1, pp. 106-111. [1883.]
4295. **Kukuk.** ——— Ueber Gasasbrüche beim Tiefbohrbetriebe. *Zeitschr. prakt. Geol.*, bd. xvii, pp. 52-54. [1909.]
4296. **Kulibin, S.** [Russian Mining Products in 1885.] 8vo, *St. Petersburg*, 1885.
4297. ——— [Russian Mining Statistics for 1887.] 8vo, *St. Petersburg*, 1890.
4298. **Kulschin.** ——— Die Schlammmvulcane der Krym. *Arch. Wiss. Russl.*, bd. iv, pp. 130-134. [1845.]
4299. **Kumborg.** ——— [Separable Burners for Kerosene Lamps.] *Journ. Manuf. Torg.*, t. v, p. 573. [1865.]
4300. **Kunth, A.** [Bituminous Gneiss of Wermiland.] *Zeitschr. deutsch. geol. Ges.*, bd. xx, pp. 226-228. [1868.]
4301. **Kuntsen, A.** Detection of Soap and Saponifiable Matters in Mineral Oils. *Petrol. Rev.*, vol. ix, p. 416. [1903.]
4302. **Kuntze, L.** Die Anwendung von Petroleum-seife bei Befall des Rübensamens mit Blattläusen. *Zeitschr. Ver. Deutsch. Zucker-Ind.*, bd. xlviii, th. 2, pp. 753, 754. [1898.]
4303. **Kupelwieser, F.** Studien über die Verwendung der Braunkohle bei der Robeisen Erzeugung (Verblüthung der Eisenerze). *Zeitschr. Berg-Hütt. Ver. Steierm. Kärnth.*, bd. xiii, pp. 260-271. [1881.]
4304. **Kupzis.** ——— Die Naphtafischgrite und ihr Einfluss auf Fische, andere Thiere und Bacterien. *Pharm. Centralt.*, bd. xliii, p. 217. [1902.]
4305. ——— [Naphtalan.] *Pharm. Journ.*, g. xlii, pp. 527-529. [1905.]
4306. **Kurbatov, V. I.** [On the Question of the Transportation of Petroleum by Rail or Pipe-line.] *Zap. Imp. Russk. Tekhn. Obsch.*, g. xix, Trudi, otd. 1, pp. 73-110. [1885.]
4307. **Kurmanov, S.** [Maikop Oil.] *Neph. Dielo*, 1910, v. 1.
4308. ——— [Determination of Mud and Water in Petroleum.] *Ibid.*, v. 6.
4309. **Kurr, J. G. v.** [Occurrence of Petroleum and Ozokerite in Galicia.] *Jahresh. Ver. Nat. Württ.*, bd. xxiv, pp. 54, 55. [1868.]
4310. **Kurasanov, N.** Aus dem Gebiete der cyclischen Verbindungen phenylirte Naphtene. Ueber das Phenylcyclohexan und einiger seiner Derivate. *Ann. Chem. Pharm.*, bd. cccviii, pp. 309-326. [1901.]
4311. **Kurtz, C. M.** Ueber die Soffioni Toscana's. *Polyt. Journ.*, bd. ccxii, pp. 493-506. [1874.]
4312. **Kusch, M.** Die Betriebssicherheit und Wirtschaftlichkeit von kleineren Heissdampf-lokomobilen, Sauggasanlagen und Dieselmotoren. *Verh. Ver. Beförd. Gewerbf.*, bd. lxxvii, pp. 373-422. [1907.]
4313. **Kusnetzov, S.** Die Glaubersalzbildung im Karaburger Busen. *Zeitschr. prakt. Geol.*, bd. vi, pp. 26, 27. [1898.]
4314. **Kusta, J.** Der Brandschiefer von Herrendorf bei Rakonitz. *Verh. k.-k. geol. Reichs.*, 1878, pp. 354-358.
4315. ——— Der Brandschiefer von Velhota. *Ibid.*, 1879, pp. 319-321.
4316. **Kutzbach, K.** Die flüssige Brennstoffe und ihre Ausnutzung in der Verbrennungskraftmaschine, mit besonderer Berücksichtigung des Dieselmotors. *Zeitschr. Ver. deutsch. Ing.*, bd. ii, pp. 521-527, 581-586. [1907.]
4317. **Kvaticovski, K.** [Practical Guide to the Manipulation of Petroleum and its Products.] *Baku*, 1894.
4318. **Kvitka, S. K.** [Methods of Determination of the Colour of Petroleum.] *Gorn. Journ.*, 1891, t. 3, pp. 134-155.
4319. ——— [Report of the Committee for the Formal Adoption of Colour Standards to Distinguish Coloured Kerosenes.] *Trudi Bukinsk. Otd. Imp. Russk. Tekhn. Obsch.*, 1889-1891, pp. 145-178. [1892.]
4320. ——— [Report of the Committee on the Question of the Solubility of Naphtha-soap in Kerosene.] *Ibid.*, 1893, July-Aug., pp. 1-26.
4321. ——— [Comparison of Russian and American Kerosenes.] *Ibid.*, pp. 27-55.
4322. ——— [Occurrence of the Sarmatian Series in the Apscheron Peninsula.] *Gorn. Journ.*, 1899, t. 2, pp. 449-491, map.
4323. ——— [Khidirzindi, Baku.] *Bull. Com. géol. Russ.*, t. xxiv, pp. 297-346, pl. vi. [1905.]
4324. ——— [Kiljazi, Baku.] *Ibid.*, pp. 467-532. [1905.]
4325. **Kyle, J. J. J.** El Petróleo de la Provincia de Jujuy. *An. Soc. Ci. Argent.*, t. vii, p. 241. [1881.]
4326. ——— La Concentración de los Minerales por el Aceite Sistema Elmore. *Ibid.*, t. iv, pp. 5-9. [1903.]
4327. **Kyle, J. J. J.**, see **Aguirre, E.**; **Hauthal, R.**; and **Nystromer, C.**
4327. **A.** Das Vorkommen von Petroleum in Australien und Indien. *Berg-Gest.*, bd. xvi, p. 5. [1871.]
4328. **A.** Erhöhung des Flammpunktes von Petroleum oder Verbesserung der Petroleum-Lampe. *Chem. Rev. Fett-Harz-Ind.*, bd. iii, pp. 177-183. [1896.]
4329. **L.** ——— Pétrole ou Charbon pour la marine? *Echo Mines Métal.*, 1911.
4330. **L.** ——— **H.** Elsassische Petroleumquellen im 17 Jahrhundert.

4331. **L.** — J. Un Moteur à Pétrole. *La Nature*, xvi, p. 124. [1896.]  
**L.** — L., see **L'ockert**, **L.**
4332. **Laas**, V. Gross-Motorschiffe. *Petroleum Zeitschr.*, bd. vi, pp. 952-956. [1911.]  
**Labarre**, —, see **Bisard**, —.
4333. **Laborde**, N. L. de. Voyage de l'Arable Pétrée. Fu, Paris, 1830.
4334. **Lach**, B. Werthbestimmung von Ozokerit. *Chem.-Zeit.*, bd. ix, pp. 905, 906. [1885.]
4335. ——— Neue Fundorte von Ozokerit. *Ibid.*, bd. xliii, p. 831. [1889.]
4336. ——— Fortschritte in der Ceresin-Industrie. *Ibid.*, bd. xviii, pp. 1889, 1890. [1894.]
4337. ——— Der gegenwärtige Stand der Ceresin-Industrie. *Chem. Rev. Fett-Harz-Ind.*, bd. i, no. 3, pp. 1-3; no. 4, pp. 3-5; no. 6, pp. 4, 5; no. 7, pp. 4-6. [1894]; no. 10, pp. 1-4. [1895.]
4338. ——— Mittheilungen aus der Ceresin-Industrie. *Chem.-Zeit.*, bd. xxi, pp. 916, 917. [1897.]
4339. ——— Der gegenwärtige Stand der Paraffin-Industrie in Oesterreich. *Seifens.-Zeit.*, bd. xxviii, halbj. 1, pp. 120, 121, 139, 140, 157, 158. [1901.]
4340. ——— Ueber das neue fractionirende Petroleumdestillations-Verfahren. *Naphta*, bd. x, pp. 213-216. [1902.]
4341. ——— Die Zeresinfabrikation. , 1909.
4342. **Lachmann**, W. Physiographie des Herzogthumes Braunschweig und des Harz-Gebirges. 8vo, Brunswick, 1851, 1852.
4343. **Lachmund**, F. Oryctographia Hildesheimensis sive amirandorum fossilium que in tractu Hildesheimii reperitur, descriptio. 4to, Hildesheim, 1669.
4344. **Lachowicz**, B. Ueber einige Kohlenwasserstoffe der Sumpfgasreihe und deren Derivate. *Ann. Chem. Pharm.*, bd. cccx, pp. 168-188. [1883.]
4345. ——— Ueber die Bestandtheile des Galizischen Petroleum. *Ibid.*, pp. 188-206. [1883.]
4346. **Ladame**, —. [Examination of Val de Travers Asphalt.] *Bull. Soc. Sci. Nat. Neuchâtel*, t. ii, pp. 210-212. [1843.]
4347. **Ladenburg**, F. Report for the years 1894, 1895 on the Trade of Mannheim and District. *Dipl. Cons. Rep.*, ann. ser., nos. 1617, 1728. [1895, 1896.]
4348. **Lafamme**, J. C. K. Report of Geological Observations in the Saguenay Region. *Ann. Rep. Geol. Surv. Canada*, 1882-84, Report D.
4349. ——— Le Gaz naturel dans la province de Quebec. *Trans. Roy. Soc. Canada*, vol. vi, Sect. 4, pp. 15-27, [1889.]
4350. **Laforest**, — de. Sur une huile minérale recueillie à la surface du sol sur les bords de la rivière Alleghany (États-Unis). *Ann. Mines*, sér. 5, t. xvi pp. 541, 542. [1859.]
4351. ——— Emploi de pétrole pour la fabrication du fer. *Ibid.*, sér. 7, t. ii, pp. 557, 558. [1872.]
- Lagai**, G., see **Kast**, H.
4352. **Laguenerre**, T. L. Estado de Tabasco. *Mem. Soc. Ci. Atate*, t. xvii, pp. 125-131. [1902.]
4353. **Lahore**, —. Appareil de Distillation des Schistes. Asphaltes et des Matières sèches ou liquides. *Gén. Industr.*, t. xxiv, pp. 304-308, pl. 322. [1862.]
4354. **Laing**, A. Oil Burning on board Ship. *Cassier's Mag.*, vol. xxxv, pp. 141-150. [1909.]
4355. **Laizer**, — v. [Asphalt and Petroleum of Bechelbronn and Lobsann.] *Taschenb. Min.*, bd. xvi, pp. 617-628. [1822.]
4356. **Laizer**, L. de. Note sur le Dusodile découvert en Auvergne. *Ann. Sci. Nat.*, t. xv, pp. 420-423. [1828.]
4357. **Lakes**, A. The Fuel Resources of Colorado. *Amer. Geol.*, vol. viii, pp. 7-19. [1891.]
4358. ——— The Wyoming Oil-fields. *Mines and Minerals*, vol. xix, p. 80. [1898.]
4359. ——— Natural Gas in Colorado. *Ibid.*, pp. 339, 340. [1899.]
4360. **Lakes**, A. Prospecting for Oil (Colorado). *Mines and Minerals*, vol. xix, pp. 477, 478; vol. xxi, pp. 481-483; vol. xxii, pp. 107-109. [1899, 1901.]
4361. ——— Californian Asphaltum. *Ibid.*, vol. xx, pp. 108, 109. [1899.]
4362. ——— Oil-fields of California. *Ibid.*, vol. xxi, pp. 467-470. [1901.]
4363. ——— Origin of Petroleum. *Ibid.*, pp. 540, 541. [1901.]
4364. ——— The Geology of the Oil-fields of Colorado. *Bull. Sch. Mines Colo.*, vol. i, pp. 221-226. [1901.]
4365. ——— Petroleum in Western North America. *Mines and Minerals*, vol. xxii, pp. 78-80. [1902.]
4366. ——— Oil-springs of Rio Blanco County, Colorado. *Ibid.*, vol. xxii, pp. 150-152. [1902.]
4367. ——— Oil in Colorado. *Ibid.*, pp. 256, 257. [1902.]
4368. ——— The Coal, Graphite, and Oil-field of Raton (New Mexico). *Ibid.*, pp. 350-352. [1902.]
4369. ——— The Western Oil-field of Mesa and Rio Blanco Counties (Colo.). *Ibid.*, pp. 388, 389. [1902.]
4370. ——— Why Employ a Geologist? Cases in which a Knowledge of Geology is necessary to successfully Prospect for Oils or Ores. *Ibid.*, p. 408. [1902.]
4371. ——— Natural Gas in Colorado. *Ibid.*, pp. 417, 418. [1902.]
4372. ——— Prospecting for Oil in the Region of the Cliff-dwellers of South-western Colorado. *Ibid.*, pp. 438-440. [1902.]
4373. ——— Aguilar Coal and Oil District. A Description of the Geology, the Thickness and Quality of the Coal Veins, and the Indications of Oil. *Ibid.*, vol. xxiii, pp. 196-198. [1903.]
4374. ——— The Present Oil Situation in Colorado. A Review of the Histories of the several Regions, and the Discoveries which have been made. *Ibid.*, p. 399. [1903.]
4375. ——— Coal and Asphalt Deposits along the Moffat Railway (Colo. and Utah). Geological Conditions which promise valuable Deposits at workable Depths. *Ibid.*, vol. xxiv, pp. 134-136. [1903.]
4376. ——— Oil-impregnated Volcanic Dykes in Colorado. *Ibid.*, vol. xxv, p. 394. [1905.]
4377. ——— Prospecting in the Oil Fields of Eastern and Western Colorado. *Mining Sci.*, vol. lviii, pp. 404-406, 422-424. [1908.]
4378. ——— The Origin of Oil. *Ibid.*, vol. lx, pp. 124, 125. [1909.]
4379. ——— Natural Gas in Colorado and Wyoming. *Ibid.*, p. 225. [1909.]
4380. ——— The Volcanic or Organic Origin of Oil. *Ibid.*, pp. 367, 368. [1909.]
4381. ——— The Marine Organic Origin of Petroleum. *Ibid.*, pp. 560-562. [1909.]
4382. ——— Genesis of Petroleum. *Min. Sci. Press*, vol. xcix, p. 543. [1909.]
4383. ——— The San Juan Oil Field, Utah. *Mining Sci.*, vol. lxi, pp. 412, 413. [1910.]
4384. ——— Natural Gas in the Western States. *Ibid.*, vol. lxii, Jan. 19, 1911.
4385. ——— Oil and Gas Prospects of the San Luis Valley. *Ibid.*, Feb. 16, 1911.
4386. ——— Notes on the Geology of Petroleum. *Ibid.*, p. 235. [1911.]
4387. ——— The Petroleum Fields of Colorado. *Ibid.*, p. 311. [1911.]
4388. ——— The Geology of the Boulder Oil Field. *Ibid.*, p. 341. [1911.]
4389. ——— Geology of the Florence Oil Field. *Ibid.*, p. 367. [1911.]
4390. ——— The Geology of Wyoming Petroleum Deposits. *Ibid.*, April 20, 1911.
4391. **Lalande**, J. J. F. Voyage d'Italie. Tt. 9. 12mo, Paris, 1786.
4392. **Lamalle**, D. de. Géographie Physique de la Mer Noire, de l'Intérieur de l'Afrique et de la Méditerranée. 8vo, Paris, 1807.

4393. **Lamanski, S. I.** [Examination of Lubricating Oils.] *Zap. Imp. Russk. Tekhn. Obsch.*, g. xvii, otd. i, pp. 20-29. [1883.]
4394. ——— [On Petroleum, Coal, and Water-gas.] *Ibid.*, g. xxi, v. 3, pp. 38-59; v. 4, 5, pp. 74-79; v. 7, 8, pp. 33-47. [1887.]
4395. ——— Zur Frage der Beleuchtung mittels Naphtagases. *Polyt. Journ.*, bd. cclxv, pp. 565-568. [1887.]
4396. ——— Die Mineralreichthümer Russlands. *Oesterr. Zeitschr. Berg Hütt.*, bd. i, pp. 394-397, 402, 403, 419-421, 436-439. [1902.]
4397. **Lamanski, S. I.**, and **L. U. Jawein.** [On the Influence of the Admixture of Air with Petroleum-Gas on the Illuminating Power of the latter, and on the Explosion of such Mixtures.] *Zap. Imp. Russk. Tekhn. Obsch.*, g. xxii, v. 6, pp. 76-79. [1888.]
- Lamb, F.**, see **Fordred, J.**
4398. **Lamb, H. H.** Report for 1894 on the Trade of Jeddah. *Dipl. Cons. Rep.*, ann. ser., no. 1622. [1895.]
- Lambert, P.**, see **Etard, A.**
4399. **Lambotte, C.** Instructions à l'usage des Conducteurs de Moteurs à Gaz et à Pétrole. 8vo, Liege, 1906.
4400. **Lameigné, P. de.** Le pétrole en Roumanie. *Compt. Rend. Soc. F'ind. Min.*, 1907, pp. 233-243.
4401. ——— La Formation des Pétales. *Compt. Rend. Congr. internat. Pétrole*, sess. 3, t. ii, pp. 73-79. [1910.]
- Lamétherie, J. C. de.**, see **Métherie, J. C. de la.**
4402. **Lami, E. O.**, and **A. Tharel.** Dictionnaire encyclopédique et biographique de l'industrie et des arts industriels. T. viii. Paris, 1881-1888.
4403. **Lampadius, W. A.** Resultate einer technisch-chemische Untersuchung eines fetten Bergtheers aus der Umgegend von Verden. *Journ. prakt. Chem.*, bd. xviii, pp. 315-318. [1839.]
4404. **Lancaster, S. C.** Coal Tar and Oil for Treating Roads. Experiments at Jackson (Tenn.). *Journ. Gaslighting*, vol. xcv, pp. 183, 184. [1906.]
4405. **Lancelot-Frères & Cie.** De la Pétréoline ou Paraffine molle naturelle dite Vaseline. 8vo, Paris, 1881.
4406. **Lanchester, F. W.** The Horse-power of the Petrol Motor in its Relation to Bore, Stroke, and Weight. *Proc. Inst. Automob. Eng.*, n.s., vol. i, pp. 155-220. [1907.]
4407. ——— Factors that have Contributed to the Advance of Automobile Engineering. *Ibid.*, vol. v, pp. 3-34. [1910.]
4408. **Land, P.** [Oil-springs and Mud-volcanoes of the Tapan Peninsula.] *Med. Sporn. Kavk. Med. Obsch.*, 1866, pp. 73-84, 117-160.
4409. ——— [Trans-Kuban Oil Springs on the Kudako.] *Ibid.*, 1867, pt. 4, pp. 36-41.
4410. ——— [Medical Topography of the Tapan Peninsula.] *Ibid.*, 1871, no. 12, pp. 1-104.
4411. **Lander, F. W.** Report upon the Central Division of the Fort Kearney, South Pass, and Honey Lake Wagon Road. *U.S. Senate Doc.*, vol. x, Congr. 35, sess. 2, 1859.
4412. **Landerer, J. J.** Bergöl in Zante. *Berg-Hütt.-Zeit.*, bd. xxxiii, p. 429. [1874.]
4413. **Landes, H.** The Non-Metalliferous Resources of Washington, except Coal. *Ann. Rep. Wash. Geol. Surv.*, 1901, pp. 161-213. [1902.]
4414. **Landolph, F.** Sur une nouvelle méthode synthétique pour la formation des carbures d'hydrogène. *Compt. Rend.*, t. lxxxvi, pp. 1267-1270. [1878.]
4415. **Landolt, H. H.** Ueber die Verflüchtigung des Wachses mit Paraffin. *Polyt. Journ.*, bd. cix, p. 224. [1861.]
4416. **Landolt, H. H.**, and **R. Börnstein.** Physikalisch-chemische Tabellen. 8vo, Berlin, 1883.
4417. **Lane, A.** Note on Salt Water associated with Petroleum. *Compt. Rend. Congr. internat. Pétrole*, sess. 3, t. ii, pp. 203, 204. [1910.]
4418. **Lane, A. C.** Asphalt in Delta County, Michigan. *Eng. Min. Journ.*, vol. lxxiii, p. 50. [1902.]
4419. **Lane, A. C.** Sub-surface Geology [Alcona Co., Mich.]. *Ann. Rep. Michigan Geol. Surv.*, 1901, pp. 64-76, map and pl. [1902.]
4420. ——— Deep wells and Prospects for Oil and Gas. *Ibid.*, pp. 211-237, pl. x. [1902.]
4421. ——— Oil and Gas prospects in Michigan. *Michigan Miner*, vol. ix, no. 4, pp. 9-12; no. 5, pp. 9-12. [1907.]
4422. **Lane, E.** The Coal and Mineral Resources of Peru. *Trans. Fed. Inst. Mech. Eng.*, vol. iii, pp. 750-772. [1892.]
4423. **Lang, J. C.** O petroleo do Dande. *Bol. Soc. geogr. Lisb.*, ser. 6, pp. 240-249. [1886.]
4424. **Lang, J. D.** An Historical Account of New South Wales to the close of 18—, both as a Penal Settlement and as a British Colony. 8vo, London, 1834.
4425. **Lang, O.** Das Petroleumvorkommen von Oelheim. *Glückauf*, bd. xxx, pp. 1719-1721, 1739-1741. [1894.]
4426. ——— Die Lehren von der Erdölbildung. *Ibid.*, bd. xxxi, pp. 513-515, 529-532, 541-543. [1895.]
4427. ——— Deutschlands Petroleumquellen. *Chem. Ind.*, bd. xviii, pp. 308-313. [1895.]
4428. **Lang, W. R.** The Chemical Industries of Canada. *Journ. Soc. Chem. Ind.*, vol. xxii, pp. 527-537. [1903.]
4429. ——— The Chemical Industries of the Dominion. *Trans. Canad. Inst.*, vol. viii, pp. 151-190. [1905.]
4430. **Langbein, H.** Ueber den Heizwert von Petroleumkoks und die Methode von Berthier. *Chem.-Zeit.*, bd. xxx, pp. 1115-1117. [1906.]
4431. **Langmuir, A. C.** The Determination of Sulphur in Bitumens. *Journ. Amer. Chem. Soc.*, vol. xxii, pp. 99-102. [1900.]
- Langovoi, S.**, see **Rudnev, V.**
4432. **Lankester, S. R.** Reports for 1891, 1892, on the Trade of Java. *Dipl. Cons. Rep.*, ann. ser., 1029, 1190. [1892, 1893.]
4433. **Lapparent, A. de.** Traité de Géologie. 8vo, Paris, 1883.
4434. **Larkin, H.** Asphalt and its Uses. *Journ. Assoc. Eng. Soc.*, vol. xii, pp. 292-301. [1908.]
4435. **La Roche Jacquelin.** (New Benzine Lamp, the Millar.) *Journ. Manuf. Torg.*, t. iv, pp. 1, 2. [1865.]
4436. **Laronde.** — Usage de l'Huile de Pétrole en Chimie. *Journ. Chim. Méd.*, t. ii, pp. 8-12. [1866.]
4437. **Larrea, V. de.** Report for the years 1888, 1893, on the Trade of Bilbao. *Dipl. Cons. Rep.*, nos. 612, 1398. [1889, 1894.]
4438. **Larlet, L.** Sur les gites bitumineux de la Judée et de la Coelé-Syria, et sur le mode d'arrivée de l'asphalte au milieu des eaux de la Mer Morte. *Compt. Rend.*, t. lxii, pp. 1395-1399. [1866.]
4439. ——— Essai sur la Géologie de la Palestine et des contrées avoisinantes, telles que l'Égypte et l'Arabie, comprenant les observations recueillies dans le cours de l'expédition du Duc de Lignes à la Mer Morte. *Ann. Sci. Geol.*, t. i, pp. 6-116, 149-329 [1869]; t. iii, no. 5. [1872.]
4440. ——— Exploration géologique de la Mer Morte, de la Palestine et de l'Idumée. 4to, Paris, 1877.
4441. **Lartigue.** — Rapport sur les bitumes, particulièrement sur ceux de Seyssel. *Séances Ac. Sci. Bordeaux*, 1819, pp. 43-51.
4442. **La Sagra, R. de.** [Asphalt in Vicinity of Havana, Cuba.] *Anales de Ciencias, Agricultura, Comercio y Artes, Habana*, t. iii. [1823.]
4443. ——— Notes sur l'histoire naturelle de l'île de Cuba. *Bibl. Univ.*, t. xl, pp. 325-332. [1829.]
4444. **Lasala, J. G.** Noticia del criadero de asfalto de Torrelapaja (Aragón). *Rev. Min.*, t. v, pp. 206-210. [1854.]
4445. ——— Areniscas Bituminosas ó Petrolíferas del Puerto del Escudo en los Confines de las Provincias de Santander y Burgos. *Bolet. Com. map. geol. Españ.*, t. iii, 235-241. [1876.]



4446. **Lassala, M. R.** Datos geologico-industriales de la provincia de Santander. *Bol. Com. map. geol. Bspañ.*, t. v, pp. 167-175. [1878.]
4447. **Lassaulx, A. v.** Ueber das Vorkommen des Bitumen in der Auvergne. *Verh. nat. Ver. preuss. Rheinl.*, 1868, *Sitz.*, pp. 17-19.
4448. ——— [New Fossil Resin of the Siegburg Lignite.] *Verh. nat. Ver. preuss. Rheinl.*, bd. xxxi, *Sitz.*, pp. 166-169. [1874.]
4449. ——— Die Sallinellen von Paternò am Etna und ihre neueste Eruption. *Zeitschr. deutsch. geol. Ges.*, bd. xxxi, pp. 457-472. [1879.]
4450. ——— Ueber die letzte Eruption des Schlammlavulkanen von Paternò am Südfusse des Aetna. *Jahresb. schles. Ges. Kultur*, bd. lviii, pp. 172, 173. [1880.]
4451. **Lascols, A.** Gaz Instantané. Notice sur les recherches de la carburation de l'air par les essences minérales et sur la production pratique et économique, dans les maisons particulières, d'un Gaz éclairant. 8vo, Paris, 1876.
4452. **Lashkarev, V.** [Petroleum in Volhynia, Podolia, and Bessarabia.] *Bull. Com. géol. Russ.*, t. xxvii, *Journ.*, pp. 74-76. [1908.]
4453. **Lassels, B.** Nouveau Voyage d'Italie par sept routes différentes. 8vo, Paris, 1670.
4454. **Lasteyrie, — de.** Rapport . . . d'une Commission spéciale, sur les applications du bitume à divers usages économiques. . . *Bull. Soc. Encour.*, ann. xviii, pp. 257-259. [1819.]
4455. **Laszlo, E.** Bemerkungen über die Benzinfabrikation. *Chem.-Zeit.*, bd. xxxi, pp. 356-358. [1907.]
4456. **Laszlo, E.** see **Rakuzin, M. A.**
4456. **Latimer, W. G.** Report for 1891 on the Trade of Porto Rico. *Dipl. Cons. Rep.*, ann. ser., no. 1306. [1893.]
4457. **La Touche, T. H. D.** Geology of the Upper Dehing Basin in the Singpho Hills. *Rec. Geol. Surv. Ind.*, vol. xix, pp. 111-115, map. [1886.]
4458. ——— Report on the Oil Springs at Moghal Kot in the Sherani Hills. *Ibid.*, vol. xxv, pp. 171-175, [1892.]
4459. ——— Geology of the Sherani Hills. *Ibid.*, vol. xxvi, pp. 77-96. [1893.]
4460. ——— Report on the Experimental Boring for Petroleum at Sukkur. *Rec. Geol. Surv. Ind.*, vol. xxviii, pp. 55-58. [1895.]
4461. ——— The Mineral Production of India during 1905 [and 1909]. *Rec. Geol. Surv. India*, vol. xxxiv, pt. 2, pp. 46-78; vol. xl, pp. 123-184. [1906, 1910.]
4462. **Laugier, E.** Huile de Rangoon. *Bull. Soc. Sci. Ind. Marseille*, t. iv, p. 129. [1876.]
4463. **Launay, L. de.** L'industrie des schistes bitumineux à Buxières les Mines (Allier). *Rev. Sci. Bourbonnais*, 1888, pp. 22, pl.
4464. ——— Étude sur le terrain permien de l'Aullier. *Bull. Soc. Geol. France*, sér. 3, t. xvi, pp. 298-337. [1888.]
4465. ——— Compte rendu de l'excursion . . . à Menat. . . *Ibid.*, pp. 1072-1076. [1888.]
4466. ——— De l'Origine de l'Acide Carbonique et des Produits carburés dans les Fumerolles et les Baux Minérales. *Compt. Rend. Congr. internat. Hydrol. Climatol. Géol.*, sess. 4, pp. 471-476. [1898.]
4467. ——— Excursion à quelques Mines minérales et Métallifères du Plateau Central [de France]. *Compt. Rend. Congr. Internat.*, sess. viii, pp. 938-970. [1901.]
4468. **Launay, L. de.** see **Fuchs, E.**
4468. **Laur, F.** La géographie du pétrole. *Journ. Pétr.*, t. x, pp. 289-291. [1910.]
4469. **Laurent, A.** Sur les schistes bitumineux et sur la paraffine. *Ann. Chim. Phys.*, sér. 2, t. liv, pp. 392-396. [1833.]
4470. ——— De l'huile des schistes bitumineux et de quelques produits qu'on en obtient. *Compt. Rend.*, t. iv, pp. 909-912. [1837.]
4471. ——— Mémoire sur un nouveau carbure d'hydrogène (chrysène). *Ibid.*, t. v, pp. 718, 719. [1837.]
4472. **Laurent, A.** Nouveau carbure d'hydrogène (pyrène). *Compt. Rend.*, t. v, p. 803. [1837.]
4473. ——— Recherches sur le Naphtum. *Compt. Rend.*, t. xv, pp. 739-745. [1842.]
4474. **La Vaysse, J. J. D. de.** Voyage aux îles de la Trinité, Tobago, et Margarita; et en diverses parties de Venezuela en Amérique du Sud. 2 Tt. 8vo, Paris, 1813.
4475. **Lavergne, G.** Les Gaz Inflammables dans les mines autres que celles de combustibles et dans les carrières. *Gén. Ctr.*, t. xxviii, pp. 362, 363. [1896.]
4476. ——— Le Pétrole. Gisements, essais des huiles, épuration, principales applications Industrielles. *Ibid.*, t. xxx, pp. 315-348, 363, 366, 380-382. [1897.]
4477. ——— Mannel théorique et pratique de l'Automobile sur route. Vapeur-Pétrole-Électricité. 8vo, Paris, 1900.
4478. **La Via, G. B.** Notà supra un' eruzione di un volcano fangoso della Sicilia. *Giorn. Fis.*, vol. vii, pp. 124-126. [1824.]
4479. ——— Descrizione di una nuova sorgente di Petroleo. *Atti Acc. Gioen. Sci. Nat.*, vol. vii, pp. 131-138. [1833.]
4480. **Lavrov, N. S.** [Storage of Petroleum, Reservoirs and Precautions against Fire.] *Izv. Imp. Russk. Tekhn. Obsch.*, 1902.
4481. **Lawder, A. W.** Mineralogical Statistics of the Kumaon Division. *Rec. Geol. Surv. Ind.*, vol. ii, pp. 86-94; vol. iv, pp. 19-27. [1869, 1871.]
4482. **Lawson, W.** see **Ellis, W. H.**
4482. **Lay, A. H.** Report for the year 1901 on the Trade of Japan. *Dipl. Cons. Rep.*, ann. ser., no. 2789. [1902.]
4483. **Lay, W. L.** On the Deposits of Earthwax (Ozokerite) in Europe and America. *Trans. N. York Ac. Sci.*, vol. ii, pp. 43-50. [1883.]
4484. **Layard, —.** Report for the year 1903 on the Trade of Nagasaki (Japan). *Dipl. Cons. Rep.*, ann. ser., no. 3269. [1904.]
4485. **Lazare, —.** [Turkish Oil Trade in 1910.] *Nepht. Dielo*, 1910.
4486. ——— [The Oil Lands of Grozni.] *Ibid.*, 1911.
4487. ——— [The Baku Oil Crisis.] *Ibid.*, 1911.
4488. ——— [Petroleum versus Coal.] *Gorn.-Zavodsk. Dielo*, 1911.
4489. ——— [The World's Production of Oil in 1910.] *Ibid.*, 1911.
4490. ——— [International Position of the Petroleum Market.] *Torg.-Promiscl. Gaz.*, 1911.
4491. ——— [Baku and Grozni Oil Industries.] *Ibid.*, 1911.
4492. ——— [Petroleum in the Urals.] *Ibid.*, 1911.
4493. ——— L'Industrie du Naphte à Grosny. *Journ. Pétr.*, t. xi, pp. 180, 181. [1911.]
4494. ——— L'Emploi du Combustible Liquide dans le Monde. *Ibid.*, pp. 194, 195. [1911.]
4495. ——— Bakou et Grosny. *Ibid.*, pp. 211, 212. [1911.]
4496. ——— L'Industrie du Naphte aux Etats-Unis. *Ibid.*, pp. 243, 244. [1911.]
4497. **Lazarev, M. I.** [On the Export Duties on Naphtha and its Products.] *Zap. Imp. Russk. Tekhn. Obsch.*, g. xix, otd. 1, pp. 1-11. [1885.]
4498. ——— [On the Importance of Docks of due Depth for Tank-ships for exportation of Petroleum-products from Baku.] *Ibid.*, pp. 200-231. [1885.]
4499. **Lazarev, P.** [Oil-gas producer.] *Zap. Imp. Russk. Tekhn. Obsch.*, g. xxxix, Trudi, pp. 337-374. [1905.]
4500. **Lazarovici, E. B.** [Drilling for Petroleum.] *Monit. Int. Pétr. Roum.*, t. vii, pp. 424-426. [1906.]
4501. **Leach, J. C.** Reports of the State Natural Gas Supervisor [of Indiana]. *Ann. Rep. Geol. Indiana*, vols. xx-xxvii. [1896-1903.]
4502. **Lean, B.** and **W. A. Bone.** The Behaviour of Ethylene on Explosion with less than its own volume of Oxygen. *Journ. Chem. Soc.*, vol. lxi, pp. 873-888. [1892.]

4502. **Leask, H.** Lecture on Oils for Lubrication. *Trans. Inst. Marine Eng.*, vol. xviii, pp. 16-58. [1906.]  
**Leathes, J. P.**, see **Ross, R.**
4504. **Lebedev, N. J.** [New Deposit of Petroleum, Salt, Asphalt and Ozokerite in the Kirghiz Steppes, Uralsky.] *Gornozav. Listok*, p. 2826. [1897.]
4505. ——— [The Oil-Fields of Bibi-Eibat.] *Petroleum*, vol. 1, pp. 1024-1029, 1077-1081, 1134-1143, 1192, 1193, 1198-1203. [1901.]
4506. **Le Bel, J. A.** Sur les Pétaoles du Bas Rhin. *Compt. Rend.*, t. lxxiii, pp. 499-501. [1871.]
4507. ——— Sur les Carbures Pyrogénés de Pechelbronn, Bas Rhin. *Ibid.*, t. lxxv, pp. 267-269. [1872.]
4508. ——— Sur une réaction des homologues de l'éthylène, qui peut expliquer leur absence dans les pétroles naturels. *Ibid.*, t. lxxxi, pp. 967-969. [1875.]
4509. ——— Notice sur les Gisements de Pétrole à Pechelbronn. *Bull. Soc. Hist. Nat. Colmar*, 1883-1885, pp. 445-460. [1885.]
4510. ——— Sur les Pétroles de Russie. *Compt. Rend.*, t. cliv, pp. 1017-1019. [1886.]
4511. ——— Sur la matière minérale des pétroles naturels. *Bull. Soc. Chim. Paris*, sér. 2, t. 1, pp. 359-361. [1888.]
4512. ——— Sur la constitution des pétroles saturés naturels. *Ibid.*, sér. 3, t. ii, pp. 305-307. [1889.]
4513. **Le Bel, J. A.** and **A. Muntz.** Sur la matière colorante noire des bitumens naturels. *Ibid.*, sér. 2, t. xvii, pp. 156-158. [1872.]
- Leblanc, F.**, see **Sainte-Claire-Deville, C. J.**
4514. **Le Brun, A.** Note sur une Venue Ancienne de Gas grisouteux dans la Mine de Sel Gemme de Saint Laurent (Meurthe-et-Moselle). *Bull. Soc. Géol. Géol.*, t. xiii, *Mém.*, pp. 136, 137. [1900.]
4515. **Lebrun, C.** Voyages par la Moscovie, en Perse et aux Indes Orientales. 2 Tt. Fo, *Amsterdam*, 1718.
4516. **Lechatelier, —** Note sur un gisement de schistes bitumineux dans le bassin houiller de Vouvaunt (Vendée). *Ann. Mines*, sér. 3, t. xix, pp. 193-214. [1841.]
4517. **Lechatelier, L.** Essais de chauffage au pétrole sur les générateurs à foyer amovible exécutés à la Société Anonyme des Établissements Weyher et Richmond. *Bull. Soc. Encour.*, t. xcv, pp. 1169-1174. [1896.]
4518. **Lecoq, E.** La Distillation dans sur Courant de Vapeur d'Eau Surchauffée appliquée à l'Analyse des Huiles de Graissage. *Compt. Rend. Congr. internat. Chim. appl.*, sess. 4, t. 1, pp. 495-502. [1902.]
4519. ——— [Estimation of Tarry Matter in Mineral Oils.] *Bull. Soc. Chim. Belg.*, t. xxii, pp. 81-87. [1908.]
4520. **Le Conte, J. N.** The Relative Value of Light Oil as compared with Fuel Oil. *Journ. Amer. Soc. Mech. Eng.*, vol. xxxiii, pp. 876-879. [1911.]
4521. **Lecoq, H.** Observations sur le gisement de l'acide carbonique et des bitumes dans le département du Puy-du-Dôme. *Ann. Sci. Ind. Auvergne*, t. i, pp. 217-232. [1828.]
4522. ——— Description géologique du bassin de Menat en Auvergne. *Ibid.*, t. ii, pp. 433-447. [1829.]
4523. ——— Epôques géologiques de l'Auvergne. *Rev. Soc. Sav.*, sér. 4, t. v, p. 430. [1867.]
4524. **Ledien, A.** Les Nouvelles Machines Marines. 3 Tt. (Atlas fo.). 8vo, *Paris*, 1882.
4525. **Ledoux, J. W.** Gasoline Engines for Pumping Plants. *Proc. Assoc. Railw. Sup. Bridges and Edgs.*, 1899.
4526. **Ledru, A. P.** Voyage aux Iles de Ténériffe, la Trinité, etc., pendant 1796-7-8. 2 Tt. 8vo, *Paris*, 1811.
4527. **Lee, H. A.** The Asphalt Deposits of Middle Park, Colorado. *Eng. Min. Journ.*, vol. lxxvii, p. 468. [1899.]
4528. **Lee, R.** [Notes on a Sample of Oil, obtained by Distillation from the Mersey Shale.] *Proc. R. Soc. Van Diemen's L.*, vol. iii, pp. 187, 188. [1855.]
4529. **Leechmann, G. D.** Carbuirettors and Carburation. 8vo, *London*, n.d. [1909.]
4530. **Leeds, A. R.** The Geography and Geology of Petroleum. *Journ. Franklin. Inst.*, vol. xlix, pp. 347-356. [1865.]
4531. ——— Asphaltic Coal from the shale of the Huron River, Ohio. *Ann. Lyc. Nat. Hist. N. York*, vol. xi, p. 105, 106. [1875.]
4532. **Leet, A. N.** Petroleum Distillation and Modes of Testing Hydrocarbons. 8vo, *New York*, 1884.
4533. **Lefebvre, —** Notice géologique sur quelques points du département des Landes, suivie d'observations sur les dunes de Gascogne. *Ann. Mines*, sér. 3, t. ix, pp. 245-272. [1836.]
4534. ——— Notice sur les mines de bitume de Bastennes et de Gaujacq (Landes). *Ibid.*, sér. 3, t. xiii, pp. 585-594. [1838.]
4535. **Lefebvre, E.** Sur quelques Produits nouveaux extraits des Pétroles d'Amérique. *Compt. Rend.*, t. lxxvii, pp. 1352-1354. [1868.]
4536. **Lefmann, H.** Report on Asphalt Analysis, submitted to the Citizens' Municipal Association and Trades' League of Philadelphia, 1895. *Philadelphia*, 1895.
4537. **Legge, T. M.** The Products of Combustion of some Gas and Oil Stoves. *Ann. Rep. Inspect. Fact. Worksh.*, 1902, pp. 269-271.
4538. **Lehmann, E.** Flora von Polnisch-Livland, mit besonderer Berücksichtigung der Flora Nordwestrusslands. . . . *Arch. Nat. Liv. Ehst. Kurl.*, t. 2, bd. xi, pp. xiii, 432, map. [1895.]  
**Lehmann, Th.**, see **Engler, C.**
4539. **Leidenschnur, J.** Verfahren zur Verarbeitung von deutschem Erdöl. *Allgem. österr. Chem. Techn.-Zeit.*, bd. xxviii, p. 55. [1910.]
4540. **Leinweber, B.** Technische und wirtschaftliche Grundlagen der Erdölgewinnung in Oesterreich. *Petroleum Zeitschr.*, bd. iv, pp. 373-384. [1909.]
4541. ——— Erdölförderung in Boryslaw. *Ibid.*, bd. v, pp. 137-147, 193-204, 253-259. [1909.]
4542. ——— Erdölförderung. *Compt. Rend. Congr. internat. Pétrole*, sess. 3, t. ii, pp. 479-514. [1910.]
4543. **Lemaire, E.** La Dénomination des Carbures D'Hydrogène employés dans l'industrie. *Genie Civ.*, t. iv, pp. 50, 51. [1909.]
4544. **Lemberger, J. L.** On Cosmolina. *Proc. Amer. Pharm. Assoc.*, 1874, pp. 384, 507.
4545. ——— Note on Preparations of Paraffine Oil. *Ibid.*, 1875, p. 627.
4546. **Lemery, N.** Cours de Chymie. 8vo, *Paris*, 1675.
4547. **Lemes, —** de. Report for the year 1900 on the Trade of Ciudad Bolivar. *Dipl. Cons. Rep.*, ann. ser., no. 2633. [1901.]
4548. **Lemière, L.** Sur la Transformation des Végétaux en Combustibles Fossiles. *Compt. Rend. Congr. géol. en ern.*, sess. viii, pp. 502-520. [1901.]
4549. **Lenke, W.** De Bituminibus variis. 4to, *Halle*, 1805.
4550. **Lemoine, G.** Études sur les hydrocarbures et les alcools supérieurs dérivés des pétroles d'Amérique. *Bull. Soc. Chim. Paris*, sér. 2, t. xii, pp. 161-166. [1884.]
4551. **Lemoult, P.** Les chaleurs de combustion des composés organiques, envisagées comme propriété, additives. Carbures. *Compt. Rend.*, t. cxxxvi, pp. 895-898. [1903.]
4552. **Lenartowicz, S.** Paraffinhaltige, paraffinfreie Rohöle und deren Destillate. *Allgem. österr. Chem.-Techn.-Zeit.*, bd. xxvi, pp. 131, 132. [1908.]
4553. **Lengfeld, F.**, and **E. O'Neill.** A Study of California Petroleum. Preliminary Notice. *Amer. Chem. Journ.*, vol. xv, pp. 19-21. [1893.]
4554. **Lent, L. B.** Producer and Water Gas for Furnaces. [Forge Furnace equipped with Gas and Oil Burners.] *Amer. Machinist*, vol. xxxiv, pp. 692-696. [1911.]
4555. **Lenz, E.** Rapport sur un voyage à Bakou. *Rec. Acad. Sci. St. Pétersb.*, 1830, pp. 65-96.
4556. ——— Description des pseudo-volcans ou volcans bourbeux de Bakou. *Bibl. Univ.*, t. lviii, pp. 245-262. [1835.]

4557. **Leuz, E.** [Changes in the Level of the Caspian Sea.] *Journ. Minéral. Bnnt. Del.*, 1836, tch. 20, no. 5.
4558. ——— Ueber das Optische Verhalten der weissen Naphtha von Baku. *Mém. Ac. Sci. St. Pétersb.*, t. iii, pp. 3-12. [1838.]
4559. **Leo, K. J.** Das Petroleumvorkommen in Körösmező. *Ung. Montanind. Zeit.*, 1888, no. 1.
4560. **Leo, W.** Die Steinkohlen in der Weald-Formation des nördlichen und nordwestlichen Deutschlands. *Berg-Hütt. Zeit.*, bd. viii, pp. 737-740, 756-758. [1849.]
4561. ——— Ueber das Vorkommen, die Gewinnung und die Bestandtheile des Berythreer bei Edemissen und Oedensen im Königreich Hannover. *Ibid.*, bd. ix, pp. 1-3. [1850.]
4562. ——— Asphalt und Bergtheer im Hannöverschen. *Ibid.*, pp. 497, 498. [1850.]
4563. ——— Goldminen in Deutschland. *Weimar*, 1855.
4564. ——— Geognostische Beschreibung der Herrl. Meyerschen Bergwerks-Districte auf der Rhön im Königreich Bayern. *Berg-Hütt. Zeit.*, bd. xvi, pp. 89-92, 97, 98. [1857.]
4565. **Leon, E. M.** The Grosney [Grozni] Petroleum Industry. 8vo, London, 1897.
4566. **Leon, S. de.** Reseña de la situación del ojo de agua, que produce el petroleo en esta municipalidad. [Soto la Marina, Tamaulipas, Mexico.] *Mém. Gob. Est. Tamaulipas*, 1889, p. 226.
- Leonard, A.**, see **Schmidt, A.**
4567. **Leonard, A. G.** Natural Gas in the Drift of Iowa. *Proc. Iowa Acad. Sci.*, vol. iv, pp. 41-47. [1897.]
4568. ——— Geology of Dallas County. *Ann. Rep. Iowa Geol. Surv.*, vol. viii, pp. 51-118, pls. iv-vi and 2 maps (1: 126,720). [1898.]
4569. ——— Natural Gas in North Dakota. *Bull. U.S. Geol. Surv.*, no. 431, pp. 7-10, pl. i. [1911.]
- Leonard, C. C.**, see **Crocos.**
4570. **Leonard, N.** Detection of Nitronaphthalene in Mineral Oils. *Chem. News*, vol. lxxviii, p. 297. [1893.]
4571. **Leonard, K. C. v.** Handbuch einer allgemeinen topographischen Mineralogie. 3 Bde. 8vo. Frankfurt, 1805-1809.
4572. **Leonov, G.** [Copper and Petroleum Deposits of the Turzai Province.] *Izv. Obshch. Gorn. Inžen.*, 1894, tch. 7, pp. 38-50, map. [1895.]
4573. **Leopold, M. B.** Ueber die Röhrlgruben in Boryslaw. *Naphtha*, bd. ix, pp. 83-85, 143-149. [1901.]
4574. **Lepechin, I.** [Travels through various parts of Russia, 1768, 1769.] 3 T. 4to, St Petersburg, 1771-1780.
4575. **Leproux, A.** État actuel de l'Industrie du Naphte dans la Presqu'île d'Apschéron. *Ann. Mines*, sér. 9, t. ii, pp. 117-162. [1892.]
4576. **Lepsius, R.** Geologie von Deutschland und der angrenzenden Gebiete. 8vo, Stuttgart, 1837-1892.
4577. **Lerch, O.** Lignites and their Utilization, with special reference to the Texas Brown Coals. *Ann. Rep. Geol. Surv. Texas*, vol. ii, pp. 38-63. [1891.]
4578. **Lerkhe, I.** [Journey in 1733-1735 from Moscow to Astrakhan and the western shore of the Caspian Sea.] *Nova Acta Ac. Sci. Imp. Petropol.*, 1790, tch. xlii-xliv.
4579. **Le Roux, H.** Le Wyoming. *Paris*, 1904
4580. **Le Roy, G. A.** Production de Bitumes et Asphaltes. Traitement du produits de distillation des pétroles bruts par le chlorure de soufre. *Bull. Soc. Industr. Mulhouse*, t. lxxvii, p. 147. [1907.]
4581. ——— Indice de Réfraction des Pétroles. *Ann. Chim. Anal.*, t. xvi, pp. 12, 13. [1911.]
4582. **Leroy-Beaulieu, P.** Le Pétrole aux États-Unis. *Journ. Pét.*, t. xi, p. 36. [1911.]
4583. **Lesignano, Pierre de.** Traité des Bains de Lesignano. [16—.]
4584. **Lesley, J. P.** Coal O.I. (Composition, Manufactures History, and Origin). *Rep. Comm. Agricult.*, 1862 p. 429.
4585. ——— Notice of a remarkable Coal Mine or Asphalt Vein, cutting the horizontal coal measures of Wood County, Western Virginia. *Proc. Amer. Phil. Soc.*, vol. ix, pp. 183-197. [1863.]
4586. **Lesley, J. P.** Petroleum. Geological Report on Lands on Paint Lick Fork of Sandy River in Eastern Kentucky. 8vo, Philadelphia, 1865.
4587. ——— [Method of the Existence of the Petroleum on the eastern Coalfield of Kentucky.] *Proc. Amer. Phil. Soc.*, vol. x, pp. 33-68. [1865.]
4588. ——— [Recent Borings in the East Kentucky Oil Region.] *Ibid.*, pp. 187-191. [1865.]
4589. ——— [Borings on the Alleghany River at Brady's Bend, Pennsylvania.] *Ibid.*, pp. 227-241, pl. iv. [1866.]
4590. ——— A Record of fourteen Oil-wells at Brady's Bend, Armstrong County, Pa. *Ibid.*, vol. xii, pp. 562-570. [1872.]
4591. ——— Historical Sketch of Geological Explorations in Pennsylvania and other States. With an Appendix containing the Annual Reports of the State Geologist to the Board of Commissioners. *2nd Geol. Surv. Penns.*, A, pp. xxvi, 200. [1876.]
4592. ——— The Boyd's Hill Gas Well at Pittsburg. *Ibid.*, E, pp. 217-237. [1876.]
4593. ——— Note on the Comparative Geology of North-eastern Ohio and North-western Pennsylvania, and Western New York. *Ibid.*, I. [1876.]
4594. ——— Oil Well Records, selected from the collections of Mr. J. F. Carll. . . . *Proc. Amer. Phil. Soc.*, vol. xvi, pp. 346-380. [1877.]
4595. ——— [On a great Gas Well at Murraysville, in Westmoreland County, Pennsylvania.] *Ibid.*, vol. xviii, pp. 207, 208. [1880.]
4596. ——— The Geology of the Pittsburg Coal Region. *Trans. Amer. Inst. Min. Eng.*, vol. xiv, pp. 618-656. [1886.]
4597. ——— Some general considerations of the Pressure, Quantity, Composition, and Full Value of Rock Gas, or the Natural Gas of the Oil Regions of Pennsylvania. *Ann. Rep. Geol. Surv. Penns.*, 1885, pp. 657-680. [1886.]
4598. ——— The Grapeville Gas Wells. *Proc. Amer. Phil. Soc.*, vol. xxix, pp. 11-16. [1891.]
4599. ——— A summary description of the Geology of Pennsylvania. *Final Report Geol. Surv. Penns.*, vol. i, pp. xx, 720. [1892.]
- Lesley, J. P.**, see **Carll, J. F.**
4600. **Lesquereux, L.** [Indiana Coal and Oil], in Dr. R. Owen's Report of a Geological Reconnaissance of Indiana made during the year 1859-60. 8vo, Indianapolis, 1862.
4601. ——— [Origin of American Petroleum.] *Bull. Soc. Sci. Nat. Neuchâtel*, t. vii, pp. 233-239. [1866.]
4602. ——— On Fucoïdes in the Coal Formations. *Trans. Amer. Phil. Soc.*, vol. xiii, pp. 313-328. [1866.]
4603. **Lesson, R. P.** Coup d'œil sur les Iles Océaniques et le Grand Ocean. *Ann. Sci. Nat.*, t. x, pp. 172-188. [1825.]
4604. ——— Voyage autour du Monde entrepris par ordre du Gouvernement sur la corvette. *La Coquille. Paris*, 1839.
4605. **Letheby, H.** The Products of Petroleum. *Min. Journ.*, vol. xxiii, p. 620. [1863.]
4606. ——— Apparatus for the Fractional Distillation of the Volatile Oils of Petroleum, Coal-tar, etc. *Journ. Gaslighting*, vol. xii, pp. 653, 654. [1863.]
4607. ——— Results of the Experiments on the Carburization of Coal-Gas. *Chem. News*, vol. xi, pp. 126-128. [1865.]
- Letheby, H.**, see **Haywood, H.**
- Letny, A. A.**, see **Lietini, A. A.**
4608. **Leuze, A.** Die mineralogischen und geologischen Fundstätten der Kirchheimer Gegend. *Jahresb. Ver. Nat. Württ.*, bd. i, pp. xxx-xxxviii. [1894.]
4609. **Levat, E. D.** Rapport à M. le Ministre de l'Instruction publique sur les Richesses minérales de la Boukharie et du Turkestan russe. Richesses minérales des Possessions russe en Asie centrale. *Ann. Mines*, sér. 10, t. iii, pp. 181-354, pls. v-ix. [1905.]
4610. **Leverett, F.** Studies in the Indiana Natural Gas Field. *Amer. Geol.*, vol. iv, pp. 6-21. [1889.]
- Leverett, F.**, see **Butts, C.**

4611. **Leverin, H.** Commercial Methods for the Analysis of Oil Shales. *Bull. Canada Dept. Mines*, no. 59. [1910.]
4612. **Levin, I.** Beiträge zur Kenntniss des Kaukasischen Petroleum. 8vo, *Karlsruhe*, 1896.
4613. **Levin, I.**, see **Engler, C.**
4613. **Lévy, J.** De l'Asphalte et du Mastic d'Asphalte. *Bull. Soc. Ind. Min.*, sér. 2, t. 1, pp. 67-86. [1872.]
4614. **Lévy-Salvador, P.** Constructions Navales. Le Yacht a Moteur a Gaz Pauvre "Progress." *Genie Civ.*, t. lix, pp. 388-393. [1911.]
4615. **Lew, I.** Die Feuerungen mit flüssigen Brennstoffmaterialien. 8vo, *Stuttgart*, 1890.
4616. ——— Eine neue Methode zur Beurtheilung der Schmieröle. *Polyt. Journ.*, bd. cclxxx, pp. 16-19, 40-44. [1891.]
4617. **Lewes, V. B.** On the Enrichment of Coal Gas by Carburetted Materials other than Cannel. *Trans. Gas. Inst.*, 1891, pp. 62-70, 80-93.
4618. ——— On Gaseous Illuminants. *Cantor Lectures*, vol. iv, 1891.
4619. ——— The Luminosity of Coal-Gas Flames. *Journ. Chem. Soc.*, vol. lxi, pp. 322-339. [1892.]
4620. ——— The production of Oil-Gas from Russian Petroleum. *Journ. Soc. Chem. Ind.*, vol. xi, pp. 584-590. [1892.]
4621. ——— Carburetted Water Gas. *Journ. Gas-lighting*, vol. lxi, pp. 871-874, 939-945, 985. [1893.]
4622. ——— The Enrichment of Coal Gas. *Ibid.*, vol. lxi, pp. 1150-1153; vol. lxii, pp. 12-18. [1893.]
4623. ——— The Action of Heat upon Ethylene. *Proc. Roy. Soc.*, vol. lv, pp. 90-107; vol. lvii, pp. 294-404. [1894, 1895.]
4624. ——— The Cause of Luminosity in the Flames of Hydrocarbon Gases. *Ibid.*, vol. lvii, pp. 450-468. [1895.]
4625. ——— The Commercial Synthesis of Illuminating Hydrocarbons. *Journ. Soc. Arts*, vol. xliii, pp. 156-165. [1895.]
4626. ——— The Acetylene Theory of Luminosity. *Journ. Chem. Soc.*, vol. lxix, pp. 226-243. [1896.]
4627. ——— Mineral Oil as a Lubricant. *Journ. Gas-lighting*, vol. lxxix, pp. 697-699. [1902.]
4628. ——— The Use of Oil in Water-Gas, Coal-Gas, and Air-Gas Production. *Ibid.*, pp. 825-828. [1902.]
4629. ——— Oil in the Incandescent Lighting Field. *Ibid.*, pp. 1025-1028. [1902.]
4630. ——— Oil as Fuel. *Petrol. Rev.*, vol. viii, pp. 8-10, 34, 83-85, 200, 201, 224-226, 234-236. [1903.]
4631. ——— Liquid and Gaseous Fuels and the part they play in modern power production. 8vo, *London*, 1907.
4632. ——— Fuel and its future. *Cantor Lectures*, vol. viii. [1908.]
4633. **Lewin, L.** Ueber allgemeine und Hautvergiftung durch Petroleum. *Archiv path. Anat.*, bd. cxlii, pp. 35-69. [1887.]
4634. **Lewis, H. C.** On a New Substance resembling Doppelite from a Peat Bog at Seranton [Pa.]. *Proc. Amer. Phil. Soc.*, vol. xx, pp. 112-117. [1882.]
4635. **Lewis, J. A.** Kenawha Gas. *Amer. Journ.* (ser. 1), vol. xlix, pp. 209-211. [1845.]
4636. **Lewkowsitch, J.** Chemical Analysis of Oils, Fats, Waxes, and of the commercial products derived therefrom. 8vo, *London*, 1895.
4637. ——— The Laboratory Companion to Fats and Oils Industries. 8vo, *London*, 1901.
4638. ——— Oils and Fats: their Uses and Applications. *Cantor Lectures*, vol. vii. [1904.]
4639. ——— Die synthetisch Darstellung optisch-aktiven Petroleum aus Glyceriden. *Ber. deutsch. chem. Ges.*, bd. xl, pp. 4161, 4162. [1907.]
4640. ——— Zur Bestimmung von Paraffin im "unverseifbaren" animalischen Fette. *Chem. Rev. Fett-Ind.*, bd. xiv, p. 51. [1907.]
4641. **Lewy, B. K.** Note sur la Composition de la Paraffine. *Ann. Chim. Phys.*, sér. 3, t. v, pp. 395-399. [1942.]
4642. **Leymerie, A.** Mémoire pour servir à la connaissance de la division inférieure du terrain crétacé pyrénéen. *Bull. Soc. Géol. France*, sér. 2, t. xxvi, pp. 277-335, pls. ii, iii. [1869.]
4643. **Lhotsky, J.** Ueber artesischen Salzsoolen und Gasbrunnen in China. *Polyt. Journ.*, bd. xxxvii, pp. 109-114. [1830.]
4644. ——— Flammenausbrüche auf den Gebirgen von Haiti. *Zeitschr. Phys. Math. Wiss.*, bd. vii, pp. 283-286. [1830.]
4645. **Lhotsky, J.** (2). Das Erdwachs bei Boryslaw. *Oesterr. Zeitschr. Berg. Hüt.*, bd. xxxvii, p. 47. [1889.]
4646. **Libavius A.** Singularia. 12mo, *Frankfort*, 1599-1601.
4646. **Lichtenstein, R.**, see **Mittler, H.**
4647. **Liddell, —.** Report for the years 1900 and 1901 on the Trade of Roumania. *Dipl. Cons. Rep.*, ann. ser., no. 2874. [1902.]
4648. **Lidov, A. P.** [Analysis of Petroleum Coke.] *Jurn. Russk. Fiz. Khim. Obsch.*, t. xiv, pp. 323, 324. [1882.]
4649. ——— [Composition of the Asphalt of Kertch.] *Ibid.*, t. xxvii, pp. 433-436. [1895.]
4650. ——— [Composition of the Grey Oil-Sand of Baku.] *Ibid.*, t. xxviii, pp. 774-778. [1896.]
4651. ——— [Estimation of Sulphur in Petroleum.] *Ibid.*, t. xxxi, otd. 1, pp. 567-570. [1899.]
4652. ——— [Investigation of the Oil-Rocks of Baku.] *Ibid.*, pp. 780, 781. [1899.]
4653. ——— [The Dry Distillation of Alkaline Residues (Naphtha).] *Viestn. Jirov. Vesch.*, kn. iv, p. 128. [1903.]
4654. ——— [Coking of Petroleum.] *Neph. Dielo*, 1903, pp. 341-344.
4655. ——— [Petroleum Soaps as Disinfectants.] *Viestn. Jirov. Vesch.*, kn. vi, p. 107. [1905.]
4656. ——— Valuation of Acid Sludge. *Neph. Dielo*, 1907, no. 4.
4657. ——— Sur le Dosage Volumétrique de l'Hydrogène dans les Naphthes et les Bitumes. *Compt. Rend. Congr. internat. Pétrole*, sess. 3, t. ii, pp. 691-694. [1910.]
4658. **Liebau, H.** Resultate über Brannkohlenfette zur Gasfabrikation. *Magdeburg*, 1867.
4659. **Lieben, A.** Sulla costituzione dei carburi d'idrogeno C<sub>n</sub>H<sub>2n</sub>. *Giorn. Sci. Nat. Econ.*, t. ii, pp. 189-200. [1866.]
4660. **Liebermann, —.** Neue Gewinnungsmethode von Benzol, Naphtalin und Anthracen. *Sitz. Ver. Beförd. Gewerbst.*, 1882, pp. 242-250.
4661. **Liebermann, C. T.**, and **O. Burg.** Ueber die Zersetzung des Braunkohlentheeröls in der Glühhitze. *Ber. deutsch. chem. Ges.*, bd. xi, pp. 723-726. [1878.]
4662. **Liebermann, L.** Eine neue Methode zur Bestimmung des Entflammungspunktes von Petroleum. *Zeitschr. anal. Chem.*, bd. xxi, pp. 321-329. [1882.]
4663. ——— Ueber den in der Praxis zulässigen Entflammungspunkt des Petroleum. *Ibid.*, pp. 329-335. [1882.]
4664. **Liebig, J. v.** and **J. C. Poggendorff.** Handwörterbuch der reinen und angewandten Chemie. 10 Bde. *Brunswick*, 1837-1864.
4665. **Lieckfeld, G.** Die Petroleum- und Benzinmotoren, ihre Entwicklung, Konstruktion und Verwendung. 8vo, *Munich*, 1894.
4666. **Lietnii, A. A.** [On Outcrops of Tar-limestone (Asphalt) in the Simbirsk Government, district of Syzran.] *Zap. Imp. Russk. Tekhn. Obsch.*, g. viii, otd. 1, pp. 266-272. [1874.]
4667. ——— [Dry Distillation of Bituminous Minerals.] *St. Petersburg*, 1875.
4668. ——— Ueber die Zersetzung des Petroleum und des Braunkohlentheers durch Ueberhitzen. *Ber. deutsch. chem. Ges.*, bd. xi, pp. 1210-1216. [1878.]
4669. ——— [Action of High Temperature on Petroleum.] *Izv. St. Petersb. Tekhn. Inst.*, 1878, p. 79.

4670. **Lietniel, A. A.** [Manufacture of Paraffin and Mineral Oil from the brown-coal tar of Germany.] *Zap. Imp. Russk. Tekhn. Obsch.*, g. xiv, otd. 1, pp. 193-220, pl. [1880.]
4671. **Lill v. Lilienbach, K.** Journal d'un voyage géologique fait à travers toute la chaîne des Carpathes en Bukowine, en Transylvanie, et dans le Marmarosch. *Mem. Soc. géol. France*, t. i, pp. 237-316. [1833.]
4672. **Lincoln, D. F.** Report on the Structural and Economic Geology of Seneca County [New York.] *14th Ann. Rep. State Geol. N. York* (=48th Ann. Rep. N. York State Mus., vol. ii), pp. 60-125, 19 pls. [1894.]
4673. **Lindemann, B.** Die Erde. Eine gemeinverständliche Geologie. *Stuttgart*, 1911.
4674. **Lindenber, F.** The Uses of Natural Asphalt in the Arts. *Sci. Amer. Suppl.*, vol. lxi, pp. 25, 358-25, 360. [1906.]
4675. **Lindgren, W.**, and **H. W. Turner.** Marysville, California. Fo. 17, *U.S. Geol. Survey*, 1895.
4676. **Linn, A.**, and **E. Linton.** Notes on the Mountain Limestone (at the base of No. XI) in the Washington County Gas Wells. *Ann. Rep. Geol. Surv. Penns.* for 1885, pp. 222-225. [1886.]
4677. **Linnæus, C.** Museum Tessinianum, Opera Comitum Caroli Gustavi Tessin. Fo, *Stockholm*, 1753.
4678. **Linton, E.**, see **Linn, A.**
4679. **Linton, F. T. C.** On Oil-Gas Processes. *Journ. Gas-lighting*, vol. lxi, pp. 738-740. [1893.]
4679. **Linton, Laura A.** On the Technical Analysis of Asphaltum. *Journ. Amer. Chem. Soc.*, vol. xvi, pp. 809-822; vol. xviii, pp. 275-283. [1894, 1896.]
4680. **Linton, L. A.**, see **Peckham, S. F.**
4680. **Lipinski, N. K.** [On Bitumens raised in Russia.] *Zap. Imp. Russk. Tekhn. Obsch.*, g. xxx, otd. 1, pp. 126-132. [1896.]
4681. **Lipold, M. V.** Bericht über die geologischen Aufnahmen in Ober-Krain im Jahre 1856. *Jahrb. k.-k. geol. Reichs.*, bd. viii, pp. 205-234. [1858.]
4682. **Lippert, W.** Ueber Sauerstoffaufnahme trocknender Oele in Gegenwart von Mineralölen. *Zeitschr. angew. Chem.*, bd. xii, pp. 513-515, 540-543. [1899.]
4683. ——— Ueber Neuerungen in der Analyse und Fabrikation von Lacken und Firnissen. *Chem. Rev. Fett-Harz-Ind.*, bd. ix, pp. 51-54, 76-80; bd. x, pp. 73-75, 98-100, 122-125. [1902, 1903.]
4684. ——— Ueber Verfälschung von Leinölfirnis mit Mineralöl. *Chem. Rev. Fett-Harz-Ind.*, bd. xvii, pp. 215, 216. [1910.]
4685. **Lippi, C.** Il carbone fossile è la cagione de' vulcani. 8vo, *Naples*, 1820.
4686. **Lippmann, —**, and — **Gurll.** [Boring at Hånigen, Hanover.] *Ann. Mines*, sér. 7, t. x, pp. 587-589. [1876.]
4687. **Liseli, G.** [Mineralogical Researches in Moldavia and Wallachia.] *Gorn. Journ.*, 1833, t. 1, pp. 1-25, 190-215.
4688. **Lisenko, K. I.** [Sketch of the Present Condition of the Caucasian Petroleum Industry.] 1872.
4689. ——— [Present Position of the Question of the Composition of Petroleum.] *Gorn. Journ.*, 1875, t. 2, pp. 320-343.
4690. ——— [Outline of the present Oil-production of Russia, and on the use of Petroleum as Fuel.] *Zap. Imp. Russk. Tekhn. Obsch.*, g. x, otd. 1, pp. 353-449, map. [1876.]
4691. ——— [Calorific Powers of Petroleum.] *Journ. Russk. Fiz. Khim. Obsch.*, t. ix, otd. 1, pp. 290-292. [1877.]
4692. ——— [Oil-Production.] *Zap. Imp. Russk. Tekhn. Obsch.*, g. xii, otd. 1, pp. 81-282, map. [1878.]
4693. ——— Ueber russisches und amerikanisches Kerosin, und über die Beleuchtung mit schweren Mineralölen. *Polyt. Journ.*, bd. ccxxvii, pp. 78-82, 161-166. [1878.]
4694. **Lisenko, K. I.** [Progress of the Oil Industry in 1877 and of illumination with Russian Kerosene.] *Gorn. Journ.*, 1878, t. 3, pp. 84-110.
4695. ——— [Materials for the Geology of the Apscheron Peninsula.] *Ibid.*, 1879, t. 3, pp. 87-94.
4696. ——— [On the importance of Oil Pipe-lines generally, for the Caucasian oil industry, and its present condition.] *Zap. Imp. Russk. Tekhn. Obsch.*, g. xiii, otd. 1, pp. 275-286. [1879.]
4697. ——— [Eruption on Loss Is.; concretions with vegetable remains from wells in Baku.] *Verh. k. russ. Min. Ges.*, ser. 2, bd. xiv, p. 255. [1879.]
4698. ——— Remarques sur l'état actuel de l'industrie du Pétrole au Caucase. *St. Petersburg*, 1880.
4699. ——— [Individual Opinion of a member of the Commission on Oil Pipe-Lines.] *Zap. Imp. Russk. Tekhn. Obsch.*, g. xix, otd. 1, pp. 330, 331. [1885.]
4700. ——— [Reasons for a Trans-Caucasian Pipe-Line.] *Ibid.*, g. xx, otd. 1, pp. 132-160. [1886.]
4701. ——— [Decomposition of Petroleum by Heat.] *Gorn. Journ.*, 1887, t. 2, pp. 349-352.
4702. ——— [Present State of the Baku Oil Industry.] *Zap. Imp. Russk. Tekhn. Obsch.*, g. xxii, v. 2, pp. 48-56. [1888.]
4703. ——— [On Measures for Introducing Solar Oil as Illuminant.] *Ibid.*, g. xxiv, Feb., pp. 1-14. [1890.]
4704. ——— [On the Present Direction of our Petroleum Industry.] *Ibid.*, g. xxvi, Apr., pp. 1-14. [1892.]
4705. ——— [On Illumination with Solar Oil, by the Kumberg and Makarov Lamps.] *Ibid.*, g. xxvii, Jan., pp. 1-22, 2 pls. [1893.]
4706. ——— [On the Influence of the Strength of the Sulphuric Acid used for Purifying Petroleum Oils, on their Photometric Properties.] *Ibid.*, g. xxvii, June, pp. 1-9. [1893.]
4707. ——— The Refining of Naphtha Distillates. *Petr. Rev.*, vol. i, pp. 74-76, 92, 93. [1899.]
4708. ——— Russian Petroleum and the Best Lamp for Burning it. *Ibid.*, pp. 129, 130. [1899.]
4709. ——— Lamp for Burning Heavy Illuminating Oils. *Ibid.*, vol. ii, pp. 140-142. [1900.]
4710. ——— [Prof. Kümpe's Petroleum Lamp "Lux."] *Zap. Imp. Russk. Tekhn. Obsch.*, g. xxxvii, Trudi, pp. 345-349. [1903.]
4711. **Lisenko, K. I.**, and **E. V. Koriander.** [Apparatus for Testing Kerosene.] *Ibid.*, g. xv, otd. 1, pp. 85-105, pl. [1881.]
4712. **Lisenko, K. I.**, and **A. Stepanov.** Ueber die sogen. alkalische Probe der Naphtaprodukte. *Polyt. Journ.*, bd. ccxc, pp. 139-143. [1893.]
4713. **Lishman, G. P.** Notes on Safety-Lamp Oils. *Trans. N. Engl. Inst. Min. Eng.*, vol. iv, pp. 136-138. [1905.]
4714. **List, —.** Die Petroleumindustrie Deutschlands. *Wochenschr. Ver. deutsch. Ing.*, 1880, pp. 194, 195.
4715. **Lister, M.** On a Subterranean Fungus and a Mineral Juice [Derbyshire, elaterite and asphalt]. *Phil. Trans.*, no. 100, p. 6179. [1673.]
4716. **Litvskii, —.** [Discovery of Ozokerite in the Caucasus.] *Gorn. Journ.*, 1853, t. 2, pp. 472-474.
4717. ——— [Investigation of the Asphalt Deposit near Mikhailov Station on the Sunjen Line.] *Ibid.*, 1857, t. 1, pp. 1-27.
4718. ——— [The Oil Springs Leased by Siemens Bros., and the Arrangement of their Refinery at Tsarski Kolodtsi.] *Zap. Kark. Otd. Imp. Russk. Tekhn. Obsch.*, t. iv, pp. 143-162. [1872.]
4719. **Little, G. H.** The Marine Transport of Petroleum. 8vo, *London*, 1890.
4720. ——— Flash-Point of Petroleum. *Automotor Journ.*, vol. ii, pp. 404-406. [1898.]
4721. ——— The Supply of Motor-Car Spirit, or Petrol. *Ibid.*, vol. iii, pp. 38, 39. [1898.]
4722. ——— Some Notes on Petroleum. *Ibid.*, p. 284. [1899.]
4723. **Ljubavin, N.** [Petroleum Tar.] *Journ. Russk. Fiz.-Khim. Obsch.*, t. cxxi, otd. i, pp. 358-364. [1899.]
4724. **Ljutik, J.** Ueber die Fabrication der Mineral schmieröle. *Riga. Ind. Zeit.*, 1883, no. 21.

4725. **Livachs, A.** Sur la solubilité anormale de certains corps dans les savons et résinates alcalins. *Compt. Rend.*, t. lxxxvii, pp. 249, 250. [1878.]
4726. **Liversidge, A.** The Minerals of New South Wales. *Trans. Roy. Soc. N.S. Wales*, vol. ix, pp. 153-215. [1876.]
4727. — Notes on some of the New Zealand Minerals belonging to the Otago Museum, Dunedin. *Trans. N. Zealand Inst.*, vol. x, pp. 490-505. [1878.]
4728. — Upon the Composition of some New South Wales Coals [and Kerosene Shales]. *Journ. Roy. Soc. N.S. Wales*, vol. xiv, pp. 181-212. [1881.]
4729. **Livingstone, D.** Missionary Travels and Researches in South Africa, including a Sketch of Sixteen Years' Residence in the Interior of Africa, and a Journey from the Cape of Good Hope to Loanda on the West Coast; thence across the Continent, down the River Zambesi, to the Eastern Ocean. 8vo, London, 1857.
4730. **Ljnbovsky, S.** Die Vaseline und ihre Produkte. *Seifenwiss.-Zeit.*, bd. xxxviii, pp. 680, 725, 749, 750, 773, 797, 820, 857, 881, 905, 929. [1911.]
4731. **Lobry de Bruyn, C. A.** Analyse von mit Mineralöl gemischtem Spermacetöl. *Chem.-Zeit.*, bd. xvii, p. 1453. [1893.]
4732. — Der Entflammungspunkt von Petroleum. *Ibid.*, bd. xx, pp. 251-265, 418. [1896.]
- Lobry de Bruyn, C. A.**, see **Stransky, S.**
- Locard, A.**, see **Falsan, A.**
4733. **Lockemann, G.** Ueber die Wasserstoffentwicklung im Marshschen Apparate. *Zeitschr. angew. Chem.*, bd. xix, p. 1362. [1906.]
4734. **Lockert, L.** Les Voitures à Pétrole. 8vo, Paris, 1896.
- Lockhart, A. E.**, see **Gattermann, L.**
4735. **Lockie, W. R. B.** Le pétrole dans l'Afrique du Sud. *Journ. Pétrol.*, t. i, pp. 187, 188. [1901.]
4736. **Lodge, O.** Ignition as Applied to Internal Combustion Engines. *Proc. Automob. Cycle Eng. Inst.*, vol. vi, pp. 114-124. [1904.]
4737. **Lodin, C.** Note sur certains combustibles tertiaires de l'Isirie et de la Dalmatie. *Ann. Mines*, sér. 8, t. iii, pp. 209-233. [1883.]
4738. — Note sur des Dégagements de Gaz inflammables survenus dans les mines métalliques, notamment dans celle de Pontpéan. *Ann. Mines*, sér. 9, vol. viii, Mém., pp. 40-105, pl. 1. [1895.]
4739. **Löb, A.** Ueber "Mineral-Entfärbler." *Chem. Rev. Fett-Harz-Ind.*, bd. xx, pp. 80-82. [1908.]
- Löbel, A.**, see **Edeleann, L.**
4740. **Loehell, H.** Der Gehalt der Mineralschmieröle an in Alkohollöslicher unflüchtlichem Asphalt. *Petroleum Zeitschr.*, bd. vi, pp. 774, 775. [1911.]
4741. — Die flüssigen Brennstoffe und ihre Verwendbarkeit in Gross-Kraftmaschinen. *Ibid.*, pp. 946-952. [1911.]
4742. — Die Chlorirung von Naturasphalten. *Chem. Rev. Fett-Harz-Ind.*, bd. xviii, pp. 165, 166. [1911.]
4743. **Löffler, E.** Om Flammedannelse hos Vulkanerne. *Forh. Skand. Nat.*, bt. ix, pp. 357-362. [1865.]
4744. **Loew, O.** On Wheelerite, a new Fossil Resin [New Mexico]. *Amer. Journ.*, ser. 3, vol. vii, pp. 571, 572. [1874.]
4745. **Löwe, J.** Apparat zur Bestimmung des Schmelzpunktes organischer Körper. *Polyt. Journ.*, bd. cci, pp. 250-254. [1871.]
4746. **Löwe, L.** Vorkommen von Anthracit in nassanischem Rotheisenstein. *Zeitschr. prakt. Geol.*, bd. viii, pp. 341, 342. [1900.]
4747. **Loewenthal, M.** Die Adhäsionspumpe Pölschek. *Compt. Rend. Congr. internat. Pétrole*, sess. 3, t. ii, pp. 465-470. [1910.]
4748. **Loewinson-Lessing, F.** De Wladikavkaz à Tiflis par la Route Militaire de Géorgie. *Congr. geol. internat. vii, Guide* no. 22. Pp. 28, 3 pls. [1897.]
4749. **Löwy, S.** Mittheilungen aus der Petroleum-Industrie. *Chem. Rev. Fett-Harz-Ind.*, bd. xvii, p. 299. [1909.]
4750. — Der Teergehalt in Vulkanölen. (Wagenachsen-Eisenbahnölen.) *Ibid.*, bd. xvii, p. 6. [1910.]
4751. **Loftus, W. K.** On the Geology of Portions of the Turko-Persian Frontier, and of the Districts adjoining. *Quart. Journ. Geol. Soc.*, vol. xi, pp. 247-344, pl. ix. [1855.]
4752. **Logan, W. E.** Descriptive Catalogue of a Collection of the Minerals of Canada, and of its Crystalline Rocks, sent to the London International Exhibition, 1862. 8vo, Montreal, 1862.
4753. — Geological Survey of Canada. Report of Progress from its Commencement to 1863. 8vo, Montreal, 1863.
4754. **Lohest, M.** Sur la hachetteite dans l'ampélite de Chokier [Belge]. *Ann. Soc. Géol. Belg.*, t. x, pp. cxiii, cxiv. [1853.]
4755. — Sur les analogies de gisement du gaz naturel aux États-Unis et du grisou en Belgique. *Ibid.*, t. xix, Bull., pp. 44-47. [1892.]
4756. **Lohmann, D.** Ueber Schwefel im Erdöl. *Chem.-Zeit.*, bd. xxxv, pp. 1119, 1120. [1911.]
4757. — Ueber Erdölaspalt. *Chem. Rev. Fett-Harz-Ind.*, bd. xviii, pp. 107, 108. [1911.]
4758. **Lohmann, P.** Selbstentzündung von Benzin im pharmazeutischen Laboratorium. *Pharm. Zeit.*, bd. i, June 22, 1904.
4759. **L'Olivier, V.** Procédé de macadamisage bitumineux à froid, et utilisation des gisements bitumineux de la Limagne d'Anvergne. *Compt. Rend. Assoc. Franc.*, 1876, pp. 206-211.
- Lomax, E. L.**, see **Garrett, F. C.**
4760. **Lomnicki, A. M.** [The Geological Atlas of Galicia.] *Kosmos*, t. xiii, pp. 45-52. [1887.]
4761. **Longe, F. de.** Les Gisements de Pétrole au Pérou. *Gén. Cit.*, t. xxvi, pp. 167-169. [1895.]
4762. **Longobardi, E.** Algunas investigaciones sobre los petroleos Argentinos. *Buenos Ayres*, 1909.
4763. **Longridge, C. C.** Oil Motor Cars of 1902. *Proc. Inst. Mech. Eng.*, 1902, pp. 669-903, pls. 78, 79.
4764. **Loo, S. v.** [Petroleum of Banjarmasin, Surabaja and Madura, Java.] *Tijdschr. Statist. Volksw.*, 1862.
4765. — [Examination of Petroleum from Palembang Residency.] *Nat. Tijdschr. Ned. Ind.*, dl. xxix, pp. 470-472. [1867.]
- Lopez, F. O.**, see **Seminario, P. I.**
4766. **Loranski, A.** [Statistics of Russian Mining Industries for 1899.] 8vo, St. Petersburg, 1901.
- Lordier, C.**, see **Colomer, F.**
4767. **Lorenz-Heinel, —.** Neuere Kuhlmaschinen. *Munich*, 1909.
4768. **Lorezi, A.** Una visita alla salsa di Cintora nell' Appennino modenese. *In Alto*, 1901, pp. 49-51.
4769. **Lori, E.** Baicoiu. *Petroleum Zeitschr.*, bd. ii, pp. 1015-1020. 1907.
4770. **Lorié, J.** Het Brongas in Nederland. *Tijdschr. k. Nederl. Aard-Genoetsch.*, rks. 2, dl. xvi, pp. 143-177. [1899.]
4771. **Losanitch, S. M.** Die Isomerie-Arten bei den Homologen der Paraffin-Reihe. *Ber. deutsch. chem. Ges.*, bd. xxx, pp. 1917-1926, 3059, 3060; bd. xxxi, p. 91. [1897, 1898.]
4772. **Loskiel, G. H.** Geschichte der Mission der Evangelischen Brüder unter den Indianern in Nordamerika. —, 1789.
4773. **Lotz, H.** Ueber das Asphalt vorkommen von Ragusa (Sizilien) und seine wirtschaftliche Bedeutung. *Zeitschr. prakt. Geol.*, bd. xi, pp. 257-265. [1903.]
- Louguinine, W.**, see **Luginin, V. P.**
4774. **Louis, A.** Le Pétrole en Egypte. *Compt. Rend. Congr. internat. Pétrole*, sess. 3, t. ii, pp. 415 146, [1910.]
4775. **Louis, H.** The Asphalt Deposits of Trinidad. *Public Works*, vol. ii, pp. 230-238. [1904.]
4776. **Lovekin, L. D.** Notes on the Burning of Liquid Fuel. *Journ. Amer. Soc. Naval Eng.*, vol. xxiii, pp. 221-247. [1911.]
4777. **Lovibond, J. W.** On a New Method of Colour Analysis by Means of the Tintometer. *Journ. Soc. Chem. Ind.*, vol. ix, pp. 10-15. [1890.]

4773. **Lws, A. P.** On an Exploration of the East Coast of Hudson Bay, from Cape Wolstenholme to the south end of James Bay. *Ann. Rep. Geol. Surv. Canada*, n. s., vol. xiii, D. Pp. 81; 2 pls and maps, 779-781, 785. [1903.]
4779. ——— Summary Report of the Geological Survey of Canada for 1906. [1907.]
4780. **Lowe, F. A.** The Silver-Islet Mine and its Present Development. *Eng. Min. Journ.*, vol. xxxiv, pp. 320-323. [1882.]
4781. **Lowo, L. P.** Practical Testing of Oils for Gas and Fuel Purposes [Pacific Coast Gas Assoc.]. *Amer. Gas Light Journ.*, vol. lxxv, pp. 405-407. [1901.]
- Loyère, — de la, see De la Loyère, —.**
4782. **Loygorri, —, and J. Gavala.** Les Régions pétrolières de l'Espagne. *Rev. Gén. Bucharest*, July 23, 1910.
4783. **Loyssel, J. B.** Observations sur les salines, les mines d'asphalte et les manufactures du département du Bas-Rhin et du pays conquis entre le Rhin et la Moselle. *Journ. Mines*, t. liii, pp. 31-38. [1795.]
4784. **Luca, S. de.** Sulla natura del gas raccolto da una fumarola nel suolo del prosciugato Lago Fucino. *Rend. R. Acc. Sci. Napoli*, t. xiii, pp. 116, 117. [1874.]
4785. **Lucas, A. F.** The Great Oil Well near Beaumont, Texas. *Trans. Amer. Inst. Min. Eng.*, vol. xxxi, pp. 362-374, 1029-1032. [1902.]
4786. ——— Résumé de the Texas Oil Fields. *Compt. Rend. Congr. internat. Pétrole*, sess. 3, t. ii, pp. 341-364. [1910.]
4787. **Lucke, C. E.** The Heat-Engine Problem. *Trans. Amer. Soc. Mech. Eng.*, vol. xxiii, pp. 202-268. [1902.]
4788. ——— Liquid Fuel Combustion. *Ibid.*, pp. 483-510. [1902.]
4789. **Lucke, C. E., and S. M. Woodward.** The Use of Alcohol and Gasoline in Farm Engines. *U. S. Dept. Agric. Farmers' Bulletin*, no. 277. Pp. 40. [1907.]
4790. **Ludov, C.** Examen Bituminis Neocomiensis. 1758.
4791. **Ludwig, K.** Die Tertiärformation in der Umgegend von Sulz vorm Walde in Elsass. *Notizbl. Ver. Erdk. Darmstadt*, f. 3, h. xiv, pp. 65-68. [1875.]
4792. ——— Geologischen Bilder aus Italien. *Bull. Soc. Imp. Nat. Mosc.*, t. xlviii, pp. 42-131, pls. 1-viii. [1874.]
4793. **Ludzski, M. L.** [Petroleum Engines.] *Zap. Imp. Russk. Tekhn. Obsch.*, g. xxii, v. 12, pp. 134-141, pl. [1888.]
4794. **[Lüdecke, C.]** Montanwachs. *Seifenind.-Zeit.*, bd. xxxiv, pp. 1063, 1066, 1113, 1133, 1153. [1907.]
4795. ——— Fortschritte in der Montanwachsindustrie. *Ibid.*, bd. xxxvii, pp. 291, 292, 335, 383. [1910.]
4796. **Lugard, F. D.** Report for 1910 on the Trade of Hong Kong. *Colonial Rep.*, ann. ser., no. 691. [1911.]
4797. **Luginin, V. P.** Sur les chaleurs de combustion de l'heptane et de l'hexahydrotoluène. *Compt. Rend.*, t. xciii, pp. 274-276. [1881.]
4798. **Lukaszewski, A.** Elektrische Drehstromanlage für Kraftübertragung und Beleuchtung der Erdwachsgruben in Boryslaw (Galizien). *Oesterr. Zeitschr. Berg-Hütt.*, bd. xlvi, pp. 133-137. [1896.]
4799. ——— Förderschichtanlage auf den Erdwachsgrube der Galizischen Creditbank in Boryslaw. *Ibid.*, bd. l, pp. 295-300, pl. ix. [1902.]
4800. **Lunge, G.** Verbindung des schlechten Brennens von Petroleum- und Photogen-Lampen. *Polyt. Journ.*, bd. clxxi, p. 467. [1864.]
4801. ——— Die Paraffinölfabrik von J. Young [zu Bathgate, Schottland]. *Ibid.*, bd. clxxxii, pp. 456-462. [1866.]
4802. ——— Ueber die Ausföhrung der fractionirten Destillation zur Werthbestimmung von chemischen Producten. *Chem. Ind.*, bd. vii, pp. 150-158. [1884.]
4803. ——— Ueber die Entschwefelung von überhitzendem Erdöl nach der Methode von Hermann Frasch. *Zeitschr. angew. Chem.*, bd. vii, pp. 69-74. [1894.]
4804. **Lunge, G. and V. Krepelka.** Untersuchung über Asphalt. *Chem.-Zeit.*, bd. xxviii, pp. 177-180. [1904.]
4805. **Lupton, A.** Mining in North America. *Trans. Chesterfield Inst. Eng.*, vol. xiv, pp. 39-54, pls. [1885.]
4806. **Lusk, J. L.** Specifications for Standard Pavements and Street-Construction Material (Standard Asphalt Pavement). *Rep. Eng. Dept. D. C.*, 1887, pp. 104-107; 1889, pp. 187-191; 1890, pp. 162-172; 1892, pp. 247-251.
4807. **Luther, R.** Die Schmieröl- und Erdöllampen auf der russischen Ausstellung für Beleuchtungsgegenstände und Naphtaindustrie in St. Petersburg. *Polyt. Journ.*, bd. cclxxv, pp. 563-575. [1890.]
4808. ——— Ueber die Fabrication und Verwendbarkeit der Naphtalichte. *Ibid.*, bd. cclxxvi, pp. 563-568. [1890.]
4809. **Luther, R., and F. Weigert.** Ueber umkehrbare photochemische Reaktionen im homogenen Systeme. Anthracen und Dianthracen. *Zeitschr. Physik. Chem.*, bd. lii, pp. 297-328. bd. liii, pp. 385-427. [1905.]
4810. **Lutz, G.** Die Fabrikation konsistenter Maschinenfette. *Seifenind.-Zeit.*, bd. xxxi, pp. 536, 537. [1904.]
4811. **Lutz, O.** Ueber Asphalt und dessen Verwendung. *Riga. Ind. Zeit.*, bd. xxvi, p. 237. [1900.]
4812. **Lux, F.** Qualitativer Nachweis von fetten Oelen in Mineralölen. *Zeitschr. anal. Chem.*, bd. xxiv, pp. 357-362. [1885.]
4813. **Luyne, — de.** Voyage d'Exploration à la Mer Morte, à Petra, et sur la rive gauche du Jourdain. 3 T. 4to, Paris, n. d.
- Luyne, V. de, see Granier, —.**
4814. **Lvov, Th. N.** [Report on Novelties in Chemical Technics at the London International Exhibition, 1871.] *Zap. Imp. Russk. Tekhn. Obsch.*, g. v, otd. 1, pp. 392-423. [1871.]
4815. ——— [On Mineral Tar and Its Application in Public Works in France.] *Ibid.*, g. vi, otd. 1, pp. 406-412. [1872.]
4816. **Lyman, B. S.** General Report on the Punjab Oil-lands. *Fo, Lahore*, 1870.
4817. ——— Topography of the Punjab Oil Region. *Trans. Amer. Phil. Soc.*, vol. xv, pp. 1-14. [1872.]
4818. ——— Preliminary Report on the First Season's Work of the Geological Survey of Yesso. *Report to the Kaikakushi*, pp. 115-160. [1874.]
4819. ——— Geological Survey of Hokkaido. Report of Rough Surveys (in 1873) of Oil Lands in Yesso. *Ibid.*, pp. 691-631. [1875.]
4820. ——— A General Report on the Geology of Yesso. *Svo, Tokio*, 1877.
4821. ——— Geological Survey of the Oil Lands of Japan. A Report of Progress for the First Year of the Oil Surveys. *Svo, Tokio*, 1877.
4822. ——— Geological Survey of Japan. Report on the Second Year's Progress of the Survey of the Oil-lands of Japan. *Svo, Tokio*, 1878.
4823. ——— Geological Survey of Japan. Report of Progress for 1878 and 1879. *Svo, Tokio*, 1879.
4824. **Lynch, W. F.** Notice of the Narrative of the U. S. Expedition to the River Jordan and the Dead Sea. *Amer. Journ.*, ser. 2, vol. viii, pp. 317-333. [1849.]
4825. ——— Official Report of the United States Expedition to explore the Dead Sea and the River Jordan. 4to, Baltimore, 1852.
4826. **Lyne, L. F.** The Use of Kerosene Oil in Steam Boilers. *Trans. Amer. Soc. Mech. Eng.*, vol. ix, pp. 247-258. [1882.]
4827. ——— The Use of Crude Petroleum in Steam Boilers. *Ibid.*, vol. x, pp. 761-764. [1889.]
4828. **Lysle, W. S.** Petroleum Refining. *Eng. Min. Journ.*, vol. lxxxii, p. 215. [1907.]
4829. **Lyte, F. M.** Curious Association of Hydrocarbons with Rock Salt in Nature. *Chem. News*, vol. lviii, p. 87. [1888.]
4830. ——— Dangers from the Use of Natural Gas. *Ibid.*, vol. x, pp. 283, 284. [1889.]

4831. **M** —, **J. Der Petroleum-Welthandel im Jahre 1908.** *Petroleum Zeitschr.*, bd. iv, pp. 871, 872. [1909.]
4832. ——— **Hamburgs Petroleum-Handel im Jahre 1908.** *Ibid.*, bd. v, pp. 14-16. [1909.]
4833. **Mabery, C. F.** Preliminary Examination of the Canadian Sulphur-Petroleum. *Amer. Chem. Journ.*, vol. xvi, pp. 89-93. [1894.]
4834. ——— **On the Determination of Sulphur in Volatile Organic Compounds.** *Ibid.*, pp. 544-551. [1894.]
4835. ——— **Composition of the American Sulphur Petroleums.** *Journ. Franklin Inst.*, vol. cxxxix, pp. 401-424; vol. cxl, pp. 1-26. [1894, 1895.]
4836. ——— **On the Composition of the Ohio and Canadian Sulphur Petroleums.** *Proc. Amer. Acad.*, vol. xxxi, pp. 1-66. [1896.]
4837. ——— **On the Composition of American Petroleum.** *Proc. Amer. Phil. Soc.*, vol. xxxvi, pp. 126-140. [1897.]
4838. ——— **The Constituents of Pennsylvania, Ohio, and Canadian Petroleum between 150° and 220°.** *Proc. Amer. Acad.*, vol. xxxii, pp. 121-176. [1897.]
4839. ——— **Preliminary Paper on the Composition of California Petroleum.** *Amer. Chem. Journ.*, vol. xix, pp. 796-804. [1897.]
4840. ——— **On the Composition of American Petroleum.** *First Internat. Petrol. Congr.*, pp. 26-30. [1900.]
4841. ——— **On the Nitrogen Compounds in California Petroleum.** *Journ. Soc. Chem. Ind.*, vol. xix, pp. 504, 505. [1900.]
4842. ——— **Composition of Texas Petroleum.** *Journ. Amer. Chem. Soc.*, vol. xxiii, pp. 264-267. [1901.]
4843. ——— **The Composition of Petroleum. On the Hydrocarbons in Pennsylvania Petroleum with Boiling Points above 216°.** *Proc. Amer. Acad.*, vol. xxxvii, pp. 565-595. [1902.]
4844. ——— **A Résumé of the Composition and Occurrence of Petroleum.** *Proc. Amer. Phil. Soc.*, vol. xlii, pp. 36-54. [1903.]
4845. ——— **The Hydrocarbons in Canadian Petroleum with high boiling points.** *Proc. Amer. Acad.*, vol. xl, pp. 334-340. [1904.]
4846. ——— **Hydrocarbons in Santa Barbara Crude Oil.** *Ibid.*, pp. 340-346. [1904.]
4847. ——— **The Solid Paraffine Hydrocarbons that collect in certain Oil-wells in Pennsylvania.** *Ibid.*, pp. 349-355. [1904.]
4848. ——— **Composition of Commercial Paraffine.** *Ibid.*, pp. 355-360. [1904.]
4849. ——— **Composition of Commercial Vaseline, Cosmoline, and similar products.** *Ibid.*, pp. 361-362. [1904.]
4850. ——— **On the Composition of Petroleum.** *Amer. Chem. Journ.*, vol. xxxiii, pp. 251-292. [1905.]
4851. ——— **Composition of American Petroleum.** *Journ. Amer. Chem. Soc.*, vol. xxviii, pp. 415-430. [1906.]
4852. **Mabery, C. F., and D. M. Buck.** On the Hydrocarbons in heavy Texas Petroleums. *Ibid.*, vol. xxii, pp. 553-556. [1900.]
4853. **Mabery, C. F., and J. H. Eyerley.** The Artificial Production of Asphalt from Petroleum. *Amer. Chem. Journ.*, vol. xviii, pp. 141-150. [1896.]
4854. **Mabery, C. F., and O. C. Dunn.** Investigations on American Petroleum. Chemistry of the Berea Grit Petroleum. *Ibid.*, pp. 215-235. [1896.]
4855. **Mabery, C. F., and A. H. Goldstein.** On the Specific Heats and Heat of Vaporization of the Paraffin and Methylene Hydrocarbons. *Ibid.*, vol. xxviii, pp. 67-78. [1902.]
4856. **Mabery, C. F., and E. J. Hudson.** On the Butanes and Octanes in American Petroleum. *Proc. Amer. Acad.*, vol. xxxii, pp. 101-118. [1897.]
4857. ——— **Refractive Power of the Hydrocarbons and Chlorine Derivatives described in the preceding paper [no. 4838].** *Ibid.*, pp. 179-182. [1897.]
4858. ——— **On the Composition of California Petroleum.** *Ibid.*, vol. xxxvi, pp. 255-283. [1901.]
4859. **Mabery, C. F., and A. S. Kittleberger.** On the Composition of a South American Petroleum. *Ibid.*, vol. xxxii, pp. 185-191. [1897.]
4860. **Mabery, C. F., and J. H. Mathews.** On Viscosity and Lubrication. *Journ. Amer. Chem. Soc.*, vol. xxx, pp. 992-1001. [1908.]
4861. **Mabery, C. F., and O. R. Palm.** The Hydrocarbons in Ohio Trenton Limestone Petroleum. *Ibid.*, vol. xl, pp. 323-334. [1904.]
4862. **Mabery, C. F., and W. O. Quayle.** Sulphur Compounds in Canadian Petroleum. *Journ. Soc. Chem. Ind.*, vol. xix, pp. 505, 506. [1900.]
4863. ——— **The Sulphur Compounds and unsaturated Hydrocarbons in Canadian Petroleum.** *Proc. Amer. Acad.*, vol. xlii, pp. 87-113. [1905.]
4864. **Mabery, C. F., and O. J. Sieplein.** On the Chlorine Derivatives of the Hydrocarbons in California Petroleum. *Ibid.*, vol. xxxvi, pp. 283-295. [1901.]
4865. ——— **A comparative Method for Determining the Fusing Points of Asphalts.** *Journ. Amer. Chem. Soc.*, vol. xxiii, pp. 16-20. [1901.]
4866. ——— **Separation of Solid Paraffin Hydrocarbons from Petroleum without Distillation.** *Proc. Amer. Acad.*, vol. xl, pp. 346-349. [1904.]
4867. **Mabery, C. F., and A. W. Smith.** Die Schwefelverbindungen im rohen Petroleum und in Petroleum-Rückständen. *Ber. deutsch. chem. Ges.*, bd. xxii, pp. 3303-3305. [1889.]
4868. ——— **On the Composition of certain Petroleum Oils and of Refining Residues.** *Proc. Amer. Acad.*, vol. xxv, pp. 218-228. [1890.]
4869. ——— **Sulphur Compounds in Ohio Petroleum.** *Amer. Chem. Journ.*, vol. xlii, pp. 233-243; vol. xvi, pp. 83-89. [1891, 1894.]
4870. **Mabery, C. F., and S. Takano.** On the Composition of Japanese Petroleum. *Proc. Amer. Acad.*, vol. xxxvi, pp. 295-304. [1901.]
4871. **Macadam, J.** Analyses of various Mineral Substances. *Min. Mag.*, vol. viii, pp. 135-137. [1889.]
4872. ——— **On Kerosene.** *Trans. Roy. Soc. Victoria*, vol. vi, pp. 61, 62. [1865.]
4873. **Macadam, S.** On the Poisonous Nature of Crude Paraffin Oil and the products of its rectification upon fish. *Rep. Brit. Assoc.*, vol. xxxvi, Sect., pp. 41-43. [1866.]
4874. ——— **Paraffin Oils and their action upon Metals.** *Pharm. Journ.*, ser. 3, vol. viii, pp. 463, 464. [1878.]
4875. ——— **On Recent Improvements in Lighthouse Illumination, with special reference to the employment of paraffin oil.** *Trans. Scott. Soc. Arts.*, vol. x, pp. 56-72. [1883.]
4876. **Macadam, W. J.** On the Chemical Composition of a Nodule of Ozokerite found at Kinghornness. *Rep. Brit. Assoc.*, 1879, pp. 309-312.
4877. ——— **On the Chemical Composition of Butyrellite (Dana).** *Min. Mag.*, vol. vi, pp. 175-180. [1885.]
4878. ——— **The Manufacture of Gas from Paraffin Oil, with a description of a simple form of Apparatus suitable for the Distillation of Oils into Gas.** *Journ. Soc. Chem. Ind.*, vol. vi, pp. 199-204. [1887.]
4879. ——— **Processes for manufacturing Gas from Oil, with special reference to the Peebles process.** *Chem. News*, vol. lxviii, pp. 283-285, 296, 297. [1893.]
4880. **Maquire-Prinsep, J.** Examens d'un nouveau Combustible fossile. *Bibl. Univ.*, sér. 2, t. xi, pp. 68-73. [1829.]
4881. ——— **Des enduits et ciments bitumineux ou asphaltiques.** *Ibid.*, sér. 3, t. xx, pp. 415-417. [1839.]
4882. **McArthur and Jackson.** Lubrication and Lubricating Oils. 16mo, *Glasgow*, 1887.
4883. **McArthur, J.** Bitumen in Van Diemen's Land. *Min. Journ.*, vol. xxiv, p. 699. [1854.]
4884. **McArthur, J. B.** Notes on the Analysis of some Mineral Oil Gases. *Journ. Soc. Chem. Ind.*, vol. vi, pp. 810-812. [1887.]
4885. **McCalley, H.** Report on the Valley Regions of Alabama. Part I. On the Tennessee Valley Region. *Rep. Geol. Surv. Alabama*, 1896, pp. xviii, 436, pls. 1-ix, map. [1896.]
4886. **McCalley, H., and A. M. Gibson.** Report on the Coal Measures of the Plateau Region of Alabama. *Ibid.*, 1891.



4387. **McCalley, H.**, and **W. Taylor**. Report on the Valley Regions of Alabama. Part II. On the Coosa Valley Region. *Rep. Geol. Surv. Alabama*, 1897. Pp. xxii, 862, pls. x-xxxv. [1897.]
4388. **McCallie, S. W.** The Barbourville Oilfield, Kentucky. *Eng. Min. Journ.*, vol. lxxvii, pp. 12, 13. [1903.]
- McCarter, H. G.**, see **Sadtler, S. P.**
4389. **McClarty, J.** Petroleum as an Enricher. *Amer. Gas Light Journ.*, vol. xxiv, p. 54. [1876.]
4390. **McClelland, E. S.** Machinery used for pumping Natural Gas. *Nat. Gas Journ.*, vol. v, no. 10, pp. 19-23. [1911.]
4391. **Macco, A.** Die Excursion des VII internationalen Geologen-Congresses nach dem Kankasus und der Krim. *Zeitschr. prakt. Geol.*, bd. vi, pp. 196-206. [1898.]
- McCollum, E. V.**, see **Bartow, E.**
4392. **McConnell, R. G.** Report on an Exploration in the Yukon and Mackenzie Basins. *Ann. Rep. Geol. Surv. Canada*, n.s., vol. iv, report D, pp. 163. [1890.]
4393. ——— Report on the District of Athabasca comprising the Country between Peace River and Athabasca River, north of Lesser Slave Lake. *Ibid.*, vol. v, report D, pp. 67, 8 pls. [1893.]
4394. **McDaniel, A. S.** The Absorption of Hydrocarbon Gases by Non-aqueous Liquids. *Journ. Phys. Chemistry*, vol. xv, pp. 587-610. [1911.]
4395. **McDermott, W.** The Silver-Islet Vein, Lake Superior. *Eng. Min. Journ.*, vol. xxxiv, pp. 54, 55, 70, 71. [1882.]
4396. **McDonald, G.** The Gold Coast, Past and Present. [1898.]
4397. **McDonnell, E.** Report for the year 1910 on the Trade, Commerce, and Agriculture of Roumania. *Dipl. Cons. Rep.*, no. 4677. [1911.]
4398. **McDowell, J. C.** Natural Gas as an Important Trade Factor in the Pittsburg District. *Amer. Gas Light Journ.*, vol. lxxiii, p. 209. 1900.
4399. **Macedo, J. de.** As nososs Riquezas Coloniaes. *Bol. Soc. Geogr. Lisb.*, t. xviii, pp. 411-609. [1901.]
4400. **Macfadden, C. K.** The Petroleum Fields of Indiana. *Petrol. Rev.*, vol. iv, pp. 270-272, 305, 306, 322, 323, 345. [1901.]
4401. ——— On various Aspects of the Oil Industry. *Ibid.*, vol. vi, pp. 357, 417-420. [1902.]
4402. **McFadden, G. J.** The Two Stroke Converted Gas Engine for the Oil Regions. *Power*, vol. xxix, pp. 219, 220. [1908.]
4403. **McFarland, D. F.** Composition of Gas from a Well at Dexter, Kan. *Trans. Kansas Ac. Sci.*, vol. xix, pp. 60-62. [1905.]
- McFarland, D. F.**, see **Cady, H. P.**, and **Haworth, E.**
4404. **McFarland, H. B.** Oil Burning on Freight Locomotives. *Cassier's Mag.*, vol. xxxvii, pp. 610-617. [1910.]
4405. **McFarland, I.** Development of Petroleum in Nevada. *Proc. Amer. Min. Congr.*, vol. xii, pp. 418-422. [1909.]
4406. **McFarlane, T.** Silver Islet [Thunder Bay, Lake Superior]. *Trans. Amer. Inst. Min. Eng.*, vol. viii, pp. 226-253. [1880.]
4407. **MacFarren, H. W.** Ozokerite in Utah. *Min. Sci. Press.*, vol. xcix, pp. 789, 790. [1909.]
4408. **Macfarren, W. W.** Possibilities of the Commercial Automobile. *Proc. Eng. Soc. Penn.*, vol. xxv, pp. 355-415. [1909.]
4409. **McGarvey, F.** Ueber den Stickstoffgehalt des Bitumens in seine Beziehung zur Frage der Bildung des Erdöles. *Heidelberg*, 1896.
4410. **McGarvey, J.** Petroleum in the Caucasus. *Petroleum*, vol. i, pp. 170, 171. [1900.]
4411. **McGarvey, W. H.**, and **S. Stanski.** Verfahren zur Gewinnung von ölfreien, wachstartigen Paraffinen (Ceresin) aus Mineralölen. *Naphta*, bd. xii, pp. 415, 416. [1905.]
4412. **McGaughey, J. W.** On the Photogen Oils. *Intell. Observer*, vol. iv, pp. 88-94. [1864.]
4413. **McGee, W. J.** The Pleistocene History of North-eastern Iowa. *Ann. Rep. U.S. Geol. Surv.*, vol. xi, pp. 189-577, pls. ii-xi. [1891.]
- McGee, W. J.**, see **Phinney, A. J.**
4414. **McGowan, J.** Mines Statement. *Rep. Dept. Mines N. Zealand*, 1900, C 2, pp. 16; 1901, C 2, pp. 16.
4415. **McGruder, W. T.** The need for Engineering Investigation in the Production, Transmission, and Use of Natural Gas. *Nat. Gas Journ.*, vol. v, no. 8, pp. 25, 26. [1911.]
4416. **Machado, M. R.** Yacimiento de Petroleo en el Sur de Chile. *Bol. Soc. Vac. Min. Chile*, ser. 3, vol. xxi, pp. 357-362. [1909.]
4417. **McIlhiney, P. C.** The Quantitative Separation of Rosin Oil from Mineral Oils. *Journ. Amer. Chem. Soc.*, vol. xvi, pp. 385-388. [1894.]
4418. **McIvor, R. W. E.** Note on the Petroleum and Paraffin of New Zealand. *Gas World*, vol. ix, p. 601. [1888.]
4419. **McIvor, W.** Notes on Lubricants. 8vo, London, 1879.
4420. **Mack, E.** Ueber Petroleumn. *Corr. Bl. Ver. Nat. Pressburg*, bd. ii, pp. 192, 193. [1863.]
4421. **McKay, A.** Geological Explorations made during 1898-99. *Rep. Min. N. Zealand*, 1899, C 9, pp. 43.
4422. ——— Geological Explorations. General Report for the year 1900-1. *Ibid.*, 1901, C 10, pp. 36, 4 pls. [1901.]
4423. **McKenzie, A.** Voyages from Montreal, on the River St. Lawrence, through the Continent of North America to the Frozen and Pacific Oceans in the years 1789 and 1793. . . . 4to, London, 1801.
4424. **Mackenzie, A. C.** On the Occurrence of a Bituminous Mineral at Mount Gerald, Scotland. *Quart. Journ. Geol. Soc.*, vol. xix, pp. 522-521. [1863.]
4425. **Mackenzie, J.** Reports from the Examiner of Coal Fields on the Condition and Prospects of the Coal Fields, together with the Reports of the Inspector of Collieries on the State of the various Coal, Petroleum Oil, Cannel Coal, and Kerosene Shale Mines in New South Wales, etc., for the year 1872 (-1875). 4to, Sydney, 1873-1876.
4426. ——— Ditto, 1876 (-1879). *Ann. Rep. Dept. Mines N.S.W.* for 1876-1879. [1877-1880.]
- Mackenzie, K. G.**, see **Richardson, C.**
4427. **Mackie, —.** Reports on the Trade and Commerce of Angola for the years 1906 and 1908. *Dipl. Cons. Rep.*, ann. ser., nos. 3928, 4391. [1907, 1909.]
4428. **Mackie, S. J.** Torbane Hill Mineral. *Geol. Gist.*, vol. iv, pp. 369-385. [1861.]
4429. **McKinstrey, L.** Romance of Natural Gas. *Nat. Gas Journ.*, vol. v, no. 10, pp. 26, 27. [1911.]
4430. **Mackirdy, H. W.** Report for the year 1910 on the Trade of Kansas City. *Dipl. Cons. Rep.*, ann. ser., no. 4711, pp. 26-28. [1911.]
4431. **McLachlan, A. F.** Report for the year 1898 on the Trade, Commerce, etc., of the Island of Java. *Dipl. Cons. Rep.*, ann. ser., no. 2253. [1899.]
4432. **McLachlan, D. C.** Reports of the Under Secretary for Mines, etc. *Ann. Rep. Dept. Mines N.S. Wales*, 1895-1902. [1896-1903.]
4433. **MacLagan, R.** Memorandum on Petroleum in the Rawal Pindie Division. *Suppl. Punjab Govt. Gazette*, Feb. 5, 1862, p. 23.
4434. ——— Note on the Geographical Distribution of Petroleum and allied Products. *Rep. Brit. Assoc.*, 1871, Sect., pp. 180-184.
4435. ——— [Coal and Petroleum of the Punjab.] *Journ. Soc. Arts*, vol. xxx, p. 594. [1882.]
4436. **MacLaren, J. M.** The Geology of Upper Assam. *Rec. Geol. Surv. India*, vol. xxxi, pp. 179-204, pls. 19-21. [1904.]
4437. **McLaughlin, R. P.** Water Conditions in the Oil Field at Coalinga. *Min. Sci. Press*, vol. ci, p. 305. [1910.]
4438. **McLaurin, J. J.** Sketches in Crude Oil. 8vo, Harrisburg, 1896.

4939. **McLeish, J.** Annual Reports on the Mineral Production of Canada during the Calendar years 1906-1909. *Canada Dep. Mines*, nos. 26, 58, 88. [1909-1911.]
4940. **MacLennan, J. C.** On the Radio-activity of Natural Gas. *Nature*, vol. lxx, p. 151. [1904.]
4941. **McNeill, N.** Report for the year 1890 on the Trade of Java. *Dipl. Cons. Rep.*, ann. ser., no. 884. [1891.]
4942. **McOlvin, E. P.** Mining around Gas Wells. *Mines and Minerals*, vol. xxxi, p. 486. [1911.]
4943. **Macoun, J.** Geological and Topographical Notes on the Lower Peace and Athabasca Rivers. *Ann. Rep. Geol. Surv. Canada*, 1875-76, pp. 87-95. [1877.]
4944. **Macquer, J.** Dictionnaire de Chymie. 2 T. 12mo, Paris, 1766.
4945. **Macrae, A.** [The Oil Springs of America and Canada.] *Journ. Soc. Arts*, vol. x, pp. 89, 90. [1861.]
4946. **Mactear, J.** Some Notes on Persian Mining and Metallurgy. *Trans. Inst. Min. Met.*, vol. iii, pp. 1-30. [1894.]
4947. **Maderna, G.** Contributo sperimentale alla Coscienza dei Bitumi. *Compt. Rend. Congr. internat. Chim. appl.*, sess. 7, sect. iv, pp. 38-40. [1910.]
4948. **Madoule, L.** see Guiselin, A.
4949. **Maefei, F. S. de.** Trattato della formazione de Fulmini. 4to, Bologna, 1747.
4950. **Magill, S. E.** [Oil Resources of Mexico.] *U.S. Cons. Rep.*, no. 317, pp. 53-55. [1907.]
4951. **Magnier, M. D.** Nouveau Manuel complet de la fabrication et de l'emploi des huiles minérales, contenant la description des procédés et appareils de fabrication des huiles de pétrole, de boghead, de schiste, etc. 18mo, Paris, 1867.
4952. **Magnin, J.** La Hausse des Pétroles. *Journ. Pét.*, t. vii, pp. 65-68. [1907.]
4953. ——— Le Savon au Pétrole. *Ibid.*, pp. 84, 85. [1907.]
4954. ——— Les Gisements pétroliers de la République dominicaine. *Ibid.*, pp. 99-101. [1907.]
4955. ——— Le Marché du Pétrole. *Ibid.*, pp. 209-212. [1907.]
4956. ——— Le Pétrole dans la Marine. *Ibid.*, pp. 225-228, 247. [1907.]
4957. ——— L'Industrie des Schistes bitumineux. *Ibid.*, t. viii, pp. 20-23, 35-37, 51, 52, 68, 69. [1908.]
4958. ——— Le Pétrole en Italie. *Ibid.*, t. ix, pp. 1-4. [1909.]
4959. ——— Le Chauffage au Pétrole. *Ibid.*, pp. 115-117, 145, 146. [1909.]
4960. **Magnus, G.** Sur la substance connue sous le nom de cire fossile de Moldavie (Ozokerite). *Ann. Chim. Phys.*, sér. 2, t. iv, pp. 217, 218. [1833.]
4961. ——— Ueber die Entstehung von Theer aus ölbildenden Gasen. *Ann. Phys. Chem.*, bd. xc, pp. 1-12. [1853.]
4962. **Magruder, E. W.** Rapid Method for the Estimation of Sulphur in Crude Petroleum and Illuminating Oils. *Proc. Virg. Chem. Club*, vol. i, p. 53.
4963. **Maguire, —.** The Hydrocarbons of Eastern Utah, with special reference to the Deposits of Ozokerite, Gilsonite, and Elatrite. *Mines and Minerals*, vol. xx, pp. 398-400. [1900.]
4964. **Mahler, —.** Ueber die Lagerungsverhältnisse des Gerstewitz Kohlenlagers. *Journ. prakt. Chem.*, bd. lvii, pp. 19, 20. [1852.]
4965. **Mahler, P.** Sur une modification de la bombe calorimétrique de M. Berthelot, et sur la détermination industrielle du pouvoir calorifique les combustibles. *Compt. Rend.*, t. cxliii, pp. 774-776. [1891.]
4966. **Maier, E.** El petróleo de Caremapu (Chile). *Bol. Soc. Nac. Min. Chile*, ser. 3, t. xxii, pp. 402-415. [1910.]
4967. **Maier, P. J.** Het water der modderwellen te Koewoe. *Nat. Tijdschr. Ned. Ind.*, dl. i, pp. 127-129. [1850.]
4968. ——— Scheikundig onderzoek van het Minerale water nit de modderwel, voorkomende op een paal afstands van de dessa Laban, distrikt Goenoeng kending, regentschap Soerabaja. *Ibid.*, dl. vi, pp. 389-394. [1854.]
4969. ——— Scheikundig onderzoek van het water uit de modderwellen van Kalang-angar, Djengolito T. Regentschap Sldhoordij, Residentie Soerabaja. *Ibid.*, dl. xxx, pp. 225-232. [1868.]
4970. ——— Scheikundig onderzoek van het water [en gas] van den te Grisee geboorden artesischen put. *Ibid.*, dl. xxxi, pp. 425-434. [1870.]
4971. **Maihe, A.** Ueber die synthetische Naphthene und deren Derivate. *Chem.-Zeit.*, bd. xxix, pp. 437-439. [1905.]
4972. ——— Ueber eine neue Darstellungsweise von Aethylkohlenwasserstoffen. *Ibid.*, bd. xxx, pp. 37, 38. [1906.]
4973. **Maitland, A. G.** Western Australia. Annual Progress Report of the Geological Survey for the year 1900. Fo, Perth, 1901.
4974. ——— The Geology of Princess Royal Harbour with reference to the Occurrence of Oil. *Bull. Geol. Surv. W. Australia*, no. 26, pp. 27-33, map. [1907.]
4975. **Majendie, V. D.** Bristol Petroleum Explosion. . . . Petroleum-laden vessel *United*, in Bristol Dock, 21st November 1888. Fo, London, 1890.
4976. ——— Accidents with Mineral Oil Lamps. Fo, London, 1890.
4977. **Majstorovic, R. S.** Die Bestimmung der Petroleumverluste in geschlossenen Reservoiren vermittels des Entflammungspunktes. *Chem.-Zeit.*, bd. xxix, p. 309. [1905.]
4978. **Malachowski, G.** Beratungen über das neue Naphtagesetz. *Naphtha*, bd. xiv, pp. 143-145. [1906.]
4979. ——— Das Naphtagesetz. *Ibid.*, bd. xv, pp. 144-148, 163-166, 209-212, 223-228. [1907.]
4980. **Malaguti, J.** Sur l'Ozokerite de la montagne de Zietrisica, en Moldavie. *Ann. Chim. Phys.*, sér. 2, t. lxiii, pp. 390-404. [1836.]
4981. **Malbos, J. de.** Observations géologiques sur les montagnes du Vivarais. *Bull. Soc. géol. France*, t. x, pp. 325-340. [1839.]
4982. **Malcolimson, W. L.** Spindle Top [Texas]. The old Story of the Start Retold. Some Comparisons made with the Baku Field. Summary of the Advantages of Liquid Fuel. Texas Refinery Schemes. *Petroleum*, vol. ii, pp. 610-612. [1902.]
4983. **Malenkovic, B.** Beitrag zum Nachweis von Verfälschungen im Natrasphalt. *Oesterr. Chem. Zeit.*, bd. viii, pp. 123-126. [1905.]
4984. ——— Oelige Imprignierungen des Holzes und die Sparverfahren. *Asphalt-Feind.-Zeit.*, bd. vii, pp. 242, 243, 258, 259, 273, 274. [1907.]
4985. **Malepeyre, C. F.** Nouveau manuel complet du fabricant de bougies stéariques, bougies de paraffine, etc. 2 T. (n. ed.). 12mo, Paris, 1904.
4986. **Malischer, I.** [Experiments on the Use of Petroleum Fuel in Glass-melting Furnaces in the Sophy Glass Works at Astrakhan.] *Zap. Imp. Russk. Tekhn. Obsch.*, g. xxv, Dec., pp. 98-102, 1 pl. [1891.]
4987. **Mallada, D. L.** Nota sobre los Yacimientos de Petróleo y Azufre de la Provincia de Cádiz. *Bol. Com. Map. geol. Esp.*, t. xxx. [1910.]
4988. **Mallet, Capt. F.** Descriptive Account of the Isle of Trinidad. 4to, London, 1802.
4989. **Mallet, F. R.** On the Coalfields of the Nágá Hills, bordering the Lakhimpur and Sibáságar Districts, Assam. *Mem. Geol. Surv. India*, vol. xii, pp. 269-363, 3 maps. [1876.]
4990. ——— The Mud Volcanoes of Rámri and Cheduba. *Rec. Geol. Surv. Ind.*, vol. xi, pp. 188-207, plate. [1878.]
4991. ——— On the Mineral Resources of Rámri, Cheduba, and the adjacent Islands. *Ibid.*, pp. 207-223, maps. [1878.]
4992. ——— Notes on a recent Mud Eruption in Rámri Island (Arakán). *Ibid.*, vol. xii, pp. 70-72. [1879.]

4993. **Mallet, F. R.** Record of Gas and Mud Eruptions on the Arakan Coast on 12th March 1879 and in June 1843. *Rec. Geol. Surv. Ind.*, vol. xiii, pp. 206-209. [1880.]
4994. ——— Notice of a Mud Eruption in the Island of Chednha. *Ibid.*, vol. xiv, pp. 196, 197. [1881.]
4995. ——— On the Alleged Tendency of the Arakan Mud Volcanoes to burst into Eruption most frequently during the rains. *Ibid.*, vol. xviii, pp. 124, 125. [1885.]
4996. ——— A New Mud-Volcano Island [Arakan Coast, Burma.]. *Nature*, vol. lxxv, p. 460. [1907.]
- Mallet, F. R.**, see **Medlicott, H. B.**
4997. **Malo, L.** Note sur la Construction des Blocs artificiels en Béton d'Asphalte, pour les fondations maritimes. *Mém. Soc. Ing. Civ.*, 1860, pp. 359-368; 1861, p. 57.
4998. ——— Note sur l'asphalte son origine, sa préparation, ses applications. *Ann. Ponts Chauss.*, sér. 4, t. 1, pp. 69-100. [1861.]
4999. ——— Note sur les chaussées en asphalte comprimé. *Mém. Soc. Ing. Civ.*, 1864, pp. 38-42, 81-91.
5000. ——— Guide pratique pour la fabrication de l'asphalte et de bitumes. *Paris*, 1866.
5001. ——— Monographie de l'asphalte. *Ann. Gén. Civ.*, sér. 1, t. v, pp. 792-800. [1866.]
5002. ——— Note sur l'état actuel de l'industrie de l'Asphalte. *Ann. Ponts Chauss.*, sér. 5, t. xviii, pp. 267-322. [1879.]
5003. ——— L'Asphalte, son origine, sa préparation, ses applications. *Paris*, 1881.
5004. ——— Notes sur les Maçonneries Asphaltiques. *Mém. Soc. Ing. Civ.*, 1883, pt. 2, pp. 381-391.
5005. ——— Les Voies Asphaltiques de Berlin. *Ibid.*, 1885, pt. 1, pp. 166-182, 284-286, 484-490.
5006. ——— On Asphalt Roadways. *Svo, London*, 1886.
5007. ——— Les Chapes Imperméables sur les ponts en maçonnerie. *Rev. Gén. Chemins de Fer*, t. xix, sem. 2, pp. 48-57. [1896.]
- Malyarov, K. L.**, see **Nastyukov, A. M.**
5008. **Mancke, W.** Ein Weltmonopol in Petroleum, *Berlin*, 1895.
5009. **Mandel, J. A.**, and **A. Bourgougnon.** Ohio Petroleum. *Journ. Amer. Chem. Soc.*, vol. xiii, pp. 168-170. [1891.]
5010. **Manès, —.** Mémoire sur les bassins houillers de Saône et Loire. 1844.
5011. ——— Statistique mineralogique du département de Saône et Loire. 1847.
5012. **Mangin, L.** L'asphalte. *Semaine Construct.*, t. iv, pp. 389, 411, 461, 462. [1880.]
5013. **Manigier, L.** Note sur le pétrole, ses origines, ses analyses et ses divers Gisements. *Bull. Soc. industr. Min.*, sér. 3, t. iv, pp. 637-696. [1890.]
5014. **Mann, E. A.** Natural Gas in Western Australia. *Journ. Soc. Chem. Ind.*, vol. xxiv, pp. 1283, 1284. [1905.]
5015. **Manning, I. A.** Petroleum Production, Colombia. Refinery Building at Cartagena—Oil found in the Country. *U.S. Cons. Rep.*, no. 332, pp. 154, 155. [1908.]
5016. ——— Asphalt Industry, Venezuela. La Guayra. Large Deposits of High-Grade Asphalt at Inciarte. *Ibid.*, no. 357, pp. 192, 193. [1910.]
5017. **Manross, N. S.** Notice of the Pitch Lake of Trinidad. *Amer. Journ.*, ser. 2, vol. xx, pp. 153-160. [1855.]
5018. ——— Notes on the Coal and Iron Ore of the State of Guerrero, Mexico, 1857. *Ibid.*, vol. xxxix, pp. 309-312. [1865.]
5019. **Mansfeldt, H. A.** Verslag over een Onderzoek naar den Stand van de particuliere Aardoliecontingting in de Residentie Cheribon, met eenige Opmerkingen betreffende de Mogelijkheid om Aardolie te vinden in de Residentie Soerabaja. *Jaarb. Mijn. Ned. O. Ind.*, jg. v, dl. II, pp. 183-206. [1876.]
5020. **Mansfield, C. B.** Researches on Coal Tar. *Journ. Chem. Soc.*, vol. 1, pp. 144-268. [1849.]
5021. ——— On the Application of certain Liquid Hydrocarbons to Artificial Illuminations: with a Description of a New Method of Gas-lighting. *Proc. Inst. Civ. Eng.*, vol. viii, pp. 207-228. [1849.]
5022. **Mansfield, C. E.** Report for 1891-93, on the Trade of Peru. *Dipl. Cons. Rep.*, ann. ser., no. 1318. [1893.]
5023. **Many, D.** [Productive Power of Oil Refineries.] *Revista Petrolului*, t. 1, p. 397. [1908.]
- Many, D. G.**, see **Edeleanu, L.**
5024. **Maquenne, L.** Sur la synthèse naturelle des hydrocarbures végétaux. *Compt. Rend.*, t. cxiv, pp. 677-680. [1892.]
5025. **Marcel, W.** On Petroleum, its Economic Value, and a Visit to the Petroleum Wells of Canada. *Journ. Soc. Arts*, vol. xii, pp. 230-235. [1864.]
5026. **Marchand, R. F.** Ueber die Einwirkung der glühenden Metalle auf das bildende Gas. *Journ. prakt. Chem.*, bd. xxvi, pp. 478-491. [1842.]
5027. **Maico Polo.** Delle Maraviglie del Mondo. *Svo, Venice*, 1496.
5028. **Marcou, J.** Report on the Geology of a portion of Southern California. *Rep. Geol. Surv. W. of 100th Meridian*, for 1876, Appendix JJ, pp. 158-172.
5029. **Marcusson, J.** Versuche zur Abscheidung von Cholesterin und Phytosterin aus Mischungen von fetten Oel mit Mineralöl. *Mitt. k. techn. Versuchs-anst.*, bd. xviii, pp. 261-263. [1900.]
5030. ——— Abscheidung von Cholesterin und Phytosterin aus Mischungen von fetten Oel mit Mineralöl. *Ibid.*, bd. xix, pp. 259, 260. [1901.]
5031. ——— Zur Frage der Entstehung des Erdöls. *Chem. Rev. Fett-Harz-Ind.*, bd. xii, pp. 1-4. [1905.]
5032. ——— Nachweis von gelassenen fetten Oelen in Mischungen mit Mineralöl. *Ibid.*, pp. 290-293. [1905.]
5033. ——— Die Bestimmung des Wassergehalts von Oelen, Fetten, Seifen, Harzen u.s.w. *Mith. k. Mat.-prüf.-amt.*, bd. xxiii, pp. 58-63. [1905.]
5034. ——— Die Bestimmung der Flamm- und Brennpunkte von Schmierölen im offenen Tiegel. *Ibid.*, bd. xxiv, pp. 218-224. [1906.]
5035. ——— Zur Entstehung des Erdöls. *Chem.-Zeit.* bd. xxx, pp. 788, 789. [1906.]
5036. ——— Die optische Aktivität des Erdöls. *Ibid.*, bd. xxxi, pp. 419-422. [1907.]
5037. ——— Die Ursache der optischen Aktivität der Erdöle. Ein Beitrag zur Frage der Entstehung des Erdöls und der Asphalte. *Mith. k. Mat.-prüf.-amt.*, bd. xxv, pp. 124-135. [1907.]
5038. ——— Bestimmung von Mineralöl in Terpentinöl und Harzessenz. *Ibid.*, bd. xxvi, pp. 157-160. [1908.]
5039. ——— Die Farbenreaktionen des Erdöls und ihre Bedeutung für die Cholesterintheorie. *Petroleum Zeitschr.*, bd. iv, pp. 263-265. [1908.]
5040. ——— Die optisch aktiven Bestandteile des Erdöls. *Chem.-Zeit.*, bd. xxxii, pp. 377, 378, 391. [1908.]
5041. ——— Nachweis von gelassenem fetten Oel in Mischung mit Mineralöl. *Chem. Rev. Fett-Harz-Ind.*, bd. xvi, pp. 45-47. [1909.]
5042. ——— Die optisch-aktiven Bestandteile des Erdöls. *Mith. k. Mat.-prüf.-amt.*, bd. xxviii, pp. 143-155. [1910.]
5043. ——— Zur Kenntnis der Asphalte. *Chem. Rev. Fett-Harz-Ind.*, bd. xviii, pp. 47-51. [1911.]
5044. ——— Der Stearergehalt der Paraffinkerzen. *Ibid.*, pp. 210, 211. [1911.]
5045. ——— Der chemische Aufbau der hochsiedenden Mineralöle. *Chem.-Zeit.*, bd. xxxv, pp. 729-731, 742-744 [1911.]
5046. ——— Zusammensetzung und Untersuchung der Fettdestillationsrückstände. *Zeitschr. angew. Chem.*, bd. xxiv, pp. 1297-1302. [1911.]
5047. **Marcusson, J.** and **R. Eickmann.** Natur- und Kunstasphalt. *Asphalt-Teerind.-Zeit.*, bd. viii, pp. 542, 543, 561, 562, 577-579. [1908.]
5048. **Marcusson, J.** and **G. Meyerheim.** Erdöl- und Schwefelparaffin. *Zeitschr. angew. Chem.*, bd. xxiii, pp. 1057-1060. [1910.]
5049. **Marcusson, J.** and **H. Schläter.** Bestimmung von Paraffin in Ozokerit und Ceresin. *Chem.-Zeit.*, bd. xxxi, pp. 348, 349. [1907.]

- Marcusson, J., see Holde, D., and Schwarz, F.
5050. **Marezi, F. v.** Zwölf Fragmente über Geologie, oder Beleuchtung dieser Wissenschaft nach der Grundsätzen der Astronomie und der Physik. 8vo, Trieste, 1864.
5051. **Margosches, B. M.** Zur Bestimmung des Schmelzpunktes der natürlichen und künstlichen Asphalte. *Chem. Rev. Fett- Harz-Ind.*, bd. xi, pp. 277-279. [1904.]
- Margosches, B. M.**, see Donath, E.
5052. **Marigny, F. de.** Résultats principaux des expériences faites dans le laboratoire de chimie d'Alger. *Ann. Mines*, sér. 5, t. xi, pp. 661-675. [1855.]
5053. **Markfeldt, O.** Faktis, öl- und stürebständigen künstlicher Asphalt. *Asphalt-Teerind.-Zeit.*, bd. vii, pp. 372, 373. [1907.]
5054. — Asphalt, Teer und Teerpräparate als Rostverhütungsmittel. *Ibid.*, bd. viii, pp. 17, 18, 35. [1908.]
5055. **Markham, R. G. L.** Motor Omnibuses for Public Passenger Service. *Cassier's Mag.*, vol. xxx, pp. 3-16. [1906.]
- Markisio, —**, see Stange, M.
5056. **Markovnikov, V.** Ueber den Kohlenwasserstoff  $C_7H_{14}$  und dessen Derivate. *Zeitschr. Chem.*, bd. vii, pp. 268-270. [1871.]
5057. — [Researches on Caucasian Petroleum.] *Jurn. Russk. Khim. Obsch.*, t. xvi, otd. 2, pp. 294-297. [1894.]
5058. — Die aromatischen Kohlenwasserstoffe des kaukasischen Erdöls. *Ann. Chem. Pharm.*, bd. cccxxiv, pp. 89-115. [1886.]
5059. — [On Petroleum Acids.] *Jurn. Russk. Khim. Obsch.*, t. xix, otd. 2, pp. 156, 157. [1887.]
5060. — [Investigations on the Naphtha of Baku.] *Ibid.*, t. xxii, otd. 1, pp. 23-26. [1890.]
5061. — [The position of Naphthenes and their Derivatives in the System of Organic Compounds.] *Ibid.*, t. xxiv, otd. 1, pp. 141-179. [1892.]
5062. — [Study of Suberone.] *Ibid.*, t. xxv, otd. 1, pp. 364-378, 547-564. [1893.]
5063. — [Isomerie Octonaphthenic Acids.] *Ibid.*, pp. 631-654. [1893.]
5064. — [Lower Esters of Natural Naphthenic Acids.] *Ibid.*, pp. 654-653. [1893.]
5065. — Ueber das Vorkommen des Hexanaphthens in Kaukasischen Naphtha. *Ber. deutsch. chem. Ges.*, bd. xxviii, pp. 577, 578. [1895.]
5066. — [Recent Facts on the Nature of Caucasian Petroleum.] *Trudi Bak. Otd. Imp. Russk. Tekhn. Obsch.*, 1897, May-August, pp. 307-318. [1897.]
5067. — Ueber Methylcyclopentane verschiedenen Ursprungs und einige ihrer Derivate. *Ber. deutsch. chem. Ges.*, bd. xxx, pp. 1222-1226. [1897.]
5068. — Aus dem Gebiete der cyclischen Verbindungen. *Ann. Chem. Pharm.*, bd. cccci, pp. 154-202. [1898.]
5069. — Derivate der Naphten oder Cyclohexanreihe. *Ibid.*, bd. cccii, pp. 1-42. [1898.]
5070. — [On the Action of  $HNO_2$  and  $HNO_3$  on various Paraffins.] *Jurn. Russk. Khim. Obsch.*, t. xxxi, otd. 1, pp. 47-54. [1899.]
5071. — Ueber die quaternären Paraffine  $CH_4$ . *Ber. deutsch. chem. Ges.*, bd. xxxii, pp. 1445-1449; bd. xxxiii, pp. 1905-1908 [1899, 1900.]
5072. — The Chemistry of Russian Petroleum. 1st Internat. Petrol. Congr., pp. 42-44. [1900.]
5073. — On Heptanaphthylenes. *Jurn. Russk. Khim. Obsch.*, t. xxxiv, otd. 1, pp. 632-635, 720. [1902.]
5074. — [On the Benzine in Groznl Petroleum and its Chemical Composition.] *Ibid.*, pp. 635, 636. [1902.]
5075. — [Some products of Cycloheptane—Suberane, Disuberyl, Ethyl Suberane.] *Ibid.*, pp. 904-916. [1902.]
5076. — [Does Suberane exist in Petroleum?] *Ibid.*, pp. 917, 918. [1902.]
5077. **Markovnikov, V.** Ueber die Einwirkung der Nitroschwefelsäure auf gesättigte Kohlenwasserstoffe. *Ber. deutsch. chem. Ges.*, bd. xxxv, pp. 1584-1587. [1902.]
5078. — [Heptanaphthene and its Derivatives.] *Jurn. Russk. Khim. Obsch.*, t. xxxv, otd. 1, pp. 1023-1071. [1903.]
5079. — [Heptanaphthylene or Methylcyclohexane.] *Ibid.*, t. xxxvi, otd. 1, pp. 39-62. [1904.]
5080. **Markovnikov, V.**, and **M. Konovalov.** Untersuchungen über die Isomeren des Hexanaphthens (Cyclohexan). *Ber. deutsch. chem. Ges.*, bd. xxviii, pp. 1234-1237. [1895.]
5081. **Markovnikov, V.**, and **V. N. Ogloblin.** [Researches on Caucasian Petroleum.] *Jurn. Russk. Khim. Obsch.*, t. xlii, otd. 1, pp. 179-183; t. xiv, otd. 1, pp. 36-40; t. xv, otd. 1, pp. 237-268, 307-354. [1881-1883.]
5082. **Markovnikov, V.**, and **G. Stadnikov.** [Heptanaphthylene and its Derivatives.] *Ibid.*, t. xxxv, otd. 1, pp. 389-399. [1903.]
- Markovnikov, V.**, see Ragozine, V. I., and Schpadi, I.
5083. **Marks, L. S.** Horse Power, Friction Losses and Efficiencies of Gas and Oil Engines. *Trans. Amer. Soc. Mech. Eng.*, vol. xxx, pp. 423-435. [1908.]
5084. **Marquardt, L.** [Cause of inferior Luminosity of many American Oils.] *Pharmaz. Handelsbl.*, 1884.
5085. — Ein neues Verdickungsmittel der Mineral-schmieröle. *Zeitschr. anal. Chem.*, bd. xxv, pp. 159, 160. [1886.]
5086. **Marquis, E.** Ueber Petroleum im Archangel'schen Gouvernement. *Pharm. Zeitschr. Russl.*, bd. iv, pp. 49-52. [1866.]
5087. **Marquisan, H.** Des Goudrons de Houille et leurs dérivés des goudrons de pétrole. 8vo, Paris, 1835.
5088. **Marr, —** Versuche über einige Beleuchtungsmaterialien. *Geuerbbl. Württ.*, 1862, pp. 471-474.
5089. **Marschall, A. F. v.** Die Ban-Materialien des österreichischen Kaiserstaates auf der Pariser Ausstellung. *Jahrb. k.-k. geol. Reichs.*, bd. vii, pp. 747-762. [1857.]
5090. **Marsden, W.** History of Sumatra, containing an account of the Government, Laws, Customs, and Manners of the Native Inhabitants, with a Description of the Natural Productions, and a Relation of the Ancient Political State of that Island. 4to, London, 1783.
5091. **Marshall, J.** Source of Error in the use of Light Petroleum as an Extracting Medium. *Amer. Journ. Pharm.*, vol. lxxix, pp. 315-317. [1907.]
5092. **Marshall, P.** The Geology of Dunedin (New Zealand). *Quart. Journ. Geol. Soc.*, vol. lxii, pp. 381-424, pls. xxxvi-xxxix. [1906.]
5093. **Marshall, R. A.** Mineral Oil as found at the Deep Main Pits, Riddings, Derbyshire. *Trans. N. Staff. Inst. Min. Eng.*, vol. i, pp. 126-134. [1879.]
5094. **Marsillon, Ch.** Le Lac d'Asphalte de "La Brea." *La Nature*, t. xlv, p. 66. [1896.]
5095. **Martell, B.** On the Carriage of Petroleum in Bulk on Over-Sea Voyages. *Trans. Inst. Naval Archit.*, vol. xviii, pp. 1-24, pls. 1-vii. [1887.]
5096. — On Points of Interest in the Construction and Repair of Vessels carrying Oil in Bulk. *Ibid.*, vol. xxxv, pp. 1-19, pls. 1-xv. [1894.]
5097. **Martell, P. M.** Die Petroleumgewinnung in Kalifornien. *Petroleum Zeitschr.*, bd. iii, pp. 1199-1203. [1908.]
5098. **Martell, P.** Die Erdölgewinnung in Japan. *Ibid.*, bd. iv, pp. 9-11. [1908.]
5099. — Petroleumquellen in der Türkei. *Ibid.*, p. 144. [1908.]
5100. — Die Asphaltindustrie auf der Insel Trinidad. *Asphalt-Teerind.-Zeit.*, bd. viii, pp. 369, 388, 404. [1908.]
5101. **Martelli, A.** Le formazione bituminosa di Selenitza in Albanie. *Rome*, 1906.
5102. **Martens, A.** Schmieröluntersuchungen. *Mith. k. techn. Versuchsanst.*, bd. vi, Ergänzungsheft i, pp. 72, 4 pls.; bd. vii, Ergänzungsheft v, pp. 57, 84, 2 pls. [1888, 1889.]

5103. **Martens, A.** Entwurf zu einer Schmieröl-Probirmaschine. *Mitth. k. techn. Versuchsanst.*, bd. viii, pp. 1-8; bd. xxv, p. 1. [1890, 1907.]
5104. ——— Vergleichende Untersuchung von Vorrichtungen und Verfahren zur Bestimmung des Kältepunktes und des Flammpunktes von Schmierölen. *Ibid.*, pp. 53-78. [1890.]
5105. ——— Ueber die Bestimmung des Flüssigkeitsgrades von Schmieröl. *Ibid.*, pp. 143-151. [1890.]
5106. ——— Ueber die Flammpunktbestimmungen von Schmierölen. *Mitth. k. techn. Versuchsanst.*, bd. xi, pp. 37-45. [1893.]
5107. ——— Die Flammpunktprüfung von Mineral-schmierölen. *Polyt. Journ.*, bd. cxcv, pp. 189-191. [1895.]
5108. ——— Bericht über die Tätigkeit des Amtes im Betriebsjahre 1909. Abth. vi. Fur Oelprüfung. *Mitth. k. Mat.-prüf.-Amt*, bd. xxviii, pp. 437-443, 452, 453. [1910.]
5109. **Martens, A.**, and **D. Holde** Die Flammpunktbestimmung von hochsiedenden Erdöldestillaten. *Mitth. k. techn. Versuchsanst.*, bd. xvi, pp. 160-170. [1898.]
5110. **Martin, G. C.** Petroleum Fields of Alaska and Bering River Coalfields. *Bull. U.S. Geol. Surv.*, no. 225, pp. 365-382. [1904.]
5111. ——— The Petroleum Fields of the Pacific Coast of Alaska, and the Bering Coal Field. *Bull. U.S. Geol. Surv.*, no. 250. Pp. 64. [1905.]
5112. ——— Notes on the Petroleum Fields of Alaska. *Ibid.*, no. 259, pp. 128-139. [1905.]
5113. ——— Markets for Alaska Coal. *Ibid.*, no. 284, pp. 18-29. [1906.]
5114. ——— Petroleum at Controller Bay [Alaska]. *Ibid.*, no. 314, pp. 89-103. [1907.]
5115. ——— Geology and Mineral Resources of the Controller Bay Region. *Ibid.*, no. 335. Pp. 141; 10 pls. [1908.]
5116. **Martin, P. F.** Peru of the Twentieth Century. 8vo, London, 1911.
- Martini, C.**, see **Schleyer, W.**
5117. **Martinovich, — v.** Chemische Untersuchung des Galizischen Bergöls. *Chem. Ann.*, 1791, bd. i, pp. 32-39.
5118. **Martius, C. A.** Ueber die Bereitung von Leuchtgas aus Petroleum. *Ber. deutsch. chem. Ges.*, bd. i, pp. 88-91. [1868.]
5119. ——— [Chemical Industry in the United States.] *Sitz. Ver. Beförd. Gewerbl.*, 1877, pp. 3-14
5120. **Marvin, C.** The Petroleum Industry of Southern Russia. *Engineering*, vol. xxxvii, pp. 171-173, 212, 213, 258-260, 270, 296, 301, 302, 329, 330, 376, 378, 440-442. [1884.]
5121. ——— The Region of the Eternal Fire: an Account of a Journey to the Petroleum Region of the Caspian in 1883. 8vo, London, 1886.
5122. ——— The Petroleum of the Future. Baku, the Petrolia of Europe. 8vo, London, 1886.
5123. ——— The Petroleum Question. The Moloch of Paraffin. 8vo, London, 1886.
5124. ——— The Coming Deluge of Russian Petroleum, and its Bearings on British Trade. 1886.
5125. ——— England as a Petroleum Power, or the Petroleum Fields of the British Empire. London, 1887.
5126. ——— Petroleum. *Prof. Papers Roy. Eng.*, vol. xiv, pp. 223-246; 12 pls. [1888.]
5127. ——— Our Unappreciated Petroleum Empire. 8vo, London, 1889.
5128. ——— The Coming Oil Age: Petroleum—Past, Present, and Future. 8vo, London, 1889.
5129. **Marvine, A. P.** Petroleum in San Domingo. *Amer. Journ.*, ser. 3, vol. iv, p. 159. [1873.]
5130. **[Marx, E.]** Die Verseifung des Petroleums und der Vaseline. *Seifenst.-Zeit.*, bd. xxx, pp. 255, 256. [1903.]
5131. **Maslennikov, S.** [Sakhalin Oil-Deposits.] *Zap. Obsch. Teutch. Amur.*, kn. iv, pp. 1-35, 3 pls. [1894.]
5132. **Mason, —.** Letter concerning . . . a burning Well at Broseley. *Phil Trans.*, vol. xlii, pt. 2, no. 482, p. 370. [1747.]
5133. **Mason, F.** Burmah, its People and Natural Productions; or Notes on the Fauna, Flora and Minerals of Tenasserim, Pegu and Burma. Rangoon, 1863.
5134. **Mason, F. H.** Aniline Chemistry. The Manufacture of Colors and flavoring extracts from the products of Coal-tar and Petroleum. *Rep. Cons. U.S.*, vol. v, pp. 43-46. [1882.]
- Mason, S. N.**, see **Gill, A. H.**
5135. **Mason, W. P.** Viscosity of Oils. *Chem. News*, vol. i, p. 210. [1884.]
5136. **Massat, —.** Les Mines de Bitume de Seyssel-Pyrimont. *Le Naturaliste*, t. xix, p. 17. [1897.]
5137. **Masson, A.** Rapport . . . au nom du comité des art économiques, sur une Nouvelle Lampe destinée à brûler les huiles lourdes des goudrons, et inventée par M. Donny. *Bull. Soc. Encour.*, t. lvii, pp. 83-87, pl. cxviii. [1858.]
5138. **Masson, B.** Purification et usages des huiles minérales. *Compt. Rend. Assoc. Franç.*, sess. 2, pp. 337-339. [1873.]
5139. **Masters, V. F.** Informe preliminar sobre la Zona petrolifera del Norte del Peru. *Bol. Ing. Minas Peru*, no. 50. Pp. 150; 28 pls. [1907.]
5140. **Maston, —.** and — **Parisot.** Sur le dépôt des schistes bitumineux de Froide-Fontaine. 1862.
5141. **Mathei, J.** Système d'emmagasinage par immersion et circulation des barils de pétroles, essences et huiles minérales. *Gén. Ind.*, t. xxxvi, pp. 286-289, pl. 466. [1868.]
- Mathei, J.**, see **Muller, A.**
5142. **Mathews, J. A.** Classification of the Carbides; their Modes of Formation, and Reactions of Decomposition. *Journ. Amer. Chem. Soc.*, vol. xxi, pp. 647-650. [1899.]
- Mathews, J. H.**, see **Mabery, C. F.**
5143. **Mathot, R. E.** Systems of Governing and Valve-gears of European Internal Combustion Engines. *Gas and Oil Power*, vol. iii, pp. 225-229, 252-258, 279-284, 307-312. [1908.]
- Matignon, —.** see **Bertelot, M.**
5144. **Mattei, S.** Ozokerite di Montefalo nel Bolognese. *Bull. Nat. Siena*, anno xii, 1893.
5145. **Matter, O.** Analyse der Boghead-Kohle. *Journ. prakt. Chem.*, bd. lxxvii, pp. 38-44. [1859.]
- Matthew, G. F.**, see **Bailey, L. W.**
5146. **Mathias, J. F.** Oelheim, die neue deutsche Petroleum-industrie, in ihrem wahren Lichte dargestellt. Berlin, 1881.
5147. **Mattison, H.** Petroleum Legislation in India. *Rep. Cons. U.S.*, vol. xi, pp. 402-406. [1884.]
5148. **Maturin, J.** Bemerkung zur Schwefelbestimmung in flüssigen Braunstoffen (Petroleum, Oel u.s.w.) *Zeitschr. angew. Chem.*, bd. xviii, pp. 1766, 1767. [1905.]
5149. **Matuschek, J.** Ueber den Einfluss des Wassergehaltes auf den Flammpunkt und Entzündungspunkt des Petroleums. *Oesterr. Chem.-Zeit.*, bd. lv, p. 202. [1901.]
5150. **Matyasovsky, J.** Geologische Skizze der Hohen Tatra. *Jahrb. Ung. Karpathen-Ver.*, bd. vi, pp. 17-35. [1878.]
5151. ——— [Geological Researches in Western Hungary.] *Verh. k.-k. geol. Reichs.*, 1878, pp. 14-16.
5152. ——— [Deceptive Oilshow at Sarkany, Fogaras Co., Transylvania.] *Földt. Ertes.*, köt. iii, 1882.
5153. ——— Bericht über die geologische Detailaufnahme am Nordwest-Ende des Rézgebirges, in der Gegend zwischen Nagy-Baród und Felső-Darna. *Jahresb. k. ung. geol. Anst.*, 1884, pp. 31-35.
5154. ——— [Hungary in Rhyolite-tuff of Resck, Matra Mts., Hungary.] *Földt. Közl.*, köt. xv, pp. 372, 373. [1885.]
5155. ——— Bericht über die geologische Detailaufnahme am Nordwestende des Rézgebirges in dem Gebiet zwischen Nagy-Baród und Felső-Darna. *Jahresb. k. ung. geol. Anst.*, 1884, pp. 31-35. [1886.]

5156. **Matyasovsky, J.** Gutachten über das Petroleumvorkommen in der Umgebung von Sösmező im Haromszeker Komitee, Schurfterrain der Petroleumcompagnie Ganser et Consorten. *Ung. Montanind. Zeit.*, 1887, no. 27.
5157. ——— Zweites Gutachten über das Petroleumvorkommen in der Gemeinde Soosmezo, im Haromszeker Comitae. *Montan-Zeit. Oesterr.-Ung. Balkanl.*, bd. iii, no. 12. [1896.]
5158. **Mauerhofer, J.** Ueber eine Studienreise nach Süd-Russland und dem Kaukasus. *Berg-Hüt. Jahrb.*, bd. xlviii, pp. 366-377, pls. iii-vi. [1900.]
5159. **Mangham, W.** On a New Compound of Carbon and Hydrogen. *Ann. Electr.*, vol. iii, pp. 470-473. [1838.]
5160. **Maunsel, F. R.** The Mesopotamian Petroleum Field. *Geogr. Journ.*, vol. ix, pp. 528-536. [1897.]
5161. **Maureta, J., and S. Thoy Codina.** Descripción física, geológica y minera de la Provincia de Barcelona. *Mem. Com. map. geol. Espan.*, 1881, pp. xiii, 479; 9 pls., 2 maps.
5162. **Maury, M. F.** see Hale, J. P.
5163. **Mawe, J.** The Mineralogy of Derbyshire: with a Description of the most Interesting Mines in the North of England, in Scotland, and in Wales. 8vo, London, 1802.
5164. **Maximov, W.** The Grosni Naphta-Zone. Its Stratification. *Min. Journ.*, vol. lxxxi, p. 306. [1907.]
5165. **Maxon, J. H.** Changing a Plant from Natural to Artificial Gas. *Nat. Gas. Journ.*, vol. v, no. 6, pp. 32-35. [1911.]
5166. **Maxwell, H. B.** Oil Engines. *Marine Engineering*, vol. ix, pp. 358-362. [1904.]
5167. ——— The Use of Kerosene Oil in Engines built for Gasoline. *Ibid.*, vol. xi, pp. 486, 487. [1906.]
5168. **Maycock, J. D.** Geological Description of Barbadoes, with a Map of the Island. *Quart. Journ. Sci. Lit. Arts*, vol. xi, pp. 10-20. [1821.]
5169. **Mayer, —.** Ueber ein neues wachsartiges Mineral aus der Moldau. *Isis*, 1834, p. 626-628.
5170. **Mayer, A.** Einige Bemerkungen zur Kenntniss des Doppelrerts. *Landwirtsch. Versuchs-Stat.*, bd. xxix, pp. 313-315. [1883.]
5171. **Mayer, F.** Thermometerkorrekturen bei der Bestimmung des Entflammungs und Brennpunktes von Oelen. *Zeitschr. angew. Chem.*, bd. xxiii, p. 55. [1910.]
5172. ——— Ueber die Beurteilung der Leuchtgrade nach ihrem Helzwert. *Ibid.*, pp. 1515, 1516. [1910.]
5173. ——— Methode zur Bestimmung der Säure und Verseifungszahl in dunklen Oelen und Fetten. *Chem.-Zeit.*, bd. xxvix, pp. 238, 239. [1910.]
5174. **Mayer, G.** Eine Bemerkung zur Entstehung des Erdöls. *Chem.-Zeit.*, bd. xxx, p. 814. [1906.]
5175. **Mayer, J.** The Mineral Oil Industry of Scotland. *Min. Mag. Rev.*, vol. i, pp. 118-128. [1872.]
5176. ——— Torbanehill Mineral. *Ibid.*, vol. ii, pp. 1-10. [1872.]
5177. **Mayer, J. B.** Das Asphaltsteinlager des Val de Travers (Kanton Neuchâtel). 8vo, Coblenz, 1839.
5178. **Mayer, M. and V. Altmayer.** Methan-Synthesen mit Calciumhydrür. *Ber. deutsch. chem. Ges.*, bd. xli, pp. 3074-3080. [1908.]
5179. **Mayer-Eymar, C.** Ueber die geologischen Verhältnisse der Petroleum-Gegend von Montecchio bei Piacenza. *Vierteljahrsschr. Nat. Ges. Zürich*, bd. xxiii, pp. 217-226. [1887.]
5180. **Maynard, —.** [Sakhalin.] *U.S. Cons. Rep.*, 1911.
5181. **Mazzetti, L.** Distretto di Milano. *Riv. Serv. Min.*, 1897-190-. [1898-190-.]
5182. **Mazzuoli, L.** Relazione Generale [sul Servizio Minerale in el 18-]. *Ibid.*, 1892-1900. [1893-1901.]
5183. **Mead, J. R.** The Drill Hole at Wichita. *Trans. Kansas Acad. Sci.*, vol. xv, pp. 20-22. [1898.]
5184. **Mears, B.**, see Parr, S. W.
5185. **Mecklenburg, W.** Das Erdöl in Argentinien. *Chem.-Zeit.*, bd. xxxiv, pp. 1150-1152. [1910.]
5186. **Mecklenburg, W.**, see Winterfeld, G.
5187. **Medinger, E.**, see Hell, C.
5188. **Mallet, H. B.** The Coal of Assam; results of a brief visit to the Coalfields of that Province in 1865, with Geological Notes on Assam and the hills to the south of it. *Mem. Geol. Surv. India*, vol. iv, pp. 387-442. [1865.]
5189. ——— Note on the Occurrence of Petroleum in India. *Rec. Geol. Surv. Ind.*, vol. xix, pp. 185-204, 2 pls. [1886.]
5190. **Medlicott, H. B., W. T. Blanford, V. Ball, and F. R. Mallet.** A Manual of the Geology of India. 4 vols., 8vo, Calcutta, 1879 (I and II), 1881, 1887.
5191. **Mee, A.** Life in the Great Oil Fields. *Harmsworth Pop. Sci.*, pp. 93-105. [1911.]
5192. **Meidinger, —.** [Oil-Burners, round and flat.] *Bäd. Gewerbezeit.*, 1876.
5193. ——— [Air-gas and Oil-gas.] *Versamml. Mannh. Bez. Ver. deutsch Ing.*, 1876.
5194. **Meier, L.** [Geological Sketch of the Trans-Ural Kirgiz Steppes, the Dept. of Orenburg, and Notes on their Mineral Resources.] *Gorn. Journ.*, 1864, t. 1, pp. 69-99.
5195. **Meiro, A. L.** [On the Continuous Apparatus after Alexiev's System for the Distillation of Petroleum and Petroleum Residues.] *Zap. Imp. Russk. Tekhn. Obsch.*, g. xxiv, Dec., pp. 1-13. [1890.]
5196. ——— [On an Apparatus for the Continued Distillation of Petroleum Residues, with Reference to the Question of the Utilisation of Petroleum in the Centres of the Russian Markets.] *Ibid.*, g. xxvii, Apr., pp. 95-127. [1893.]
5197. **Meissner, —.** Die Naphta-Quellen bei Mendell in Irak Arabi. *Peterm. Mitth.*, bd. xx, pp. 343-346. [1874.]
5198. **Meissner, C.** Mittheilungen über Motoren Schrauben und Boote zu den Petroleum-motorbooten. 4to, Hamburg, 1893.
5199. **Meldrum, E.** Preparation of Paraffine Oil. *Chem. News*, vol. xxxix, p. 208 [1874.]
5200. **Melgunof, —.** Das südliche Ufer des Kaspischen Meeres oder die Nordprovinzen Persiens. *Leipsc.*, 1868.
5201. **Melikov, P.** [The Achalta Mud Volcanos, Tiflis.] *Jurn. Russk. Phis.-Khim. Obsch.*, t. xxviii, pp. 545-551. [1896.]
5202. **Melion, V. J.** Der Hatchettin, Mellit, und Walchowit in Mähren. *Lotus*, bd. v, pp. 122-127. [1855.]
5203. **Melnikov, —.** [On an Oil-Extraction-Process.] *Zap. Imp. Russk. Tekhn. Obsch.*, g. viii, oct. 1, pp. 101-122. [1874.]
5204. ——— [Oil-Extraction Process.] *St. Petersburg*, 1877.
5205. **Ménard de la Groye, F. J. B.** Nouvelle description des feux naturels de Pietramala et de Barigazzo dans les Apennins de Florence et de Modène, présentant l'état de ces feux en 1813 et en 1814. *Journ. Phys.*, t. lxxxv, pp. 236-263, 290-314. [1817.]
5206. ——— Description de l'état des sables du Modénais dans l'été de l'année 1814; indication des effets semblables qui ont été observés dans d'autres contrées; définition générale et rapprochement. *Ibid.*, t. lxxxvi, pp. 252-275, 342-355, 417-434. [1818.]
5207. ——— Observations sur les feux naturels de Pietramala. *Trac. Soc. R. Arts du Mans*, 1820, pp. 102-107.
5208. **Mencarelli, N.** Studi sommarii di uno schisto bituminoso nella provincia di Pesaro e Urbino. *Urbino*, 1866.
5209. **Mendel, J.** Die Neuordnung des Europäischen Petroleumkoncerts. *Petroleum Zeitschr.*, bd. ii, pp. 81-85. [1906.]
5210. ——— Die Petroleum-Weltflotte. *Ibid.*, pp. 190-193, 233-235; 357-360. [1906, 1907.]
5211. ——— Zur Bewegung auf dem Benzinmarkte. *Ibid.*, pp. 280-284. [1907.]
5212. ——— Das Petroleumvorkommen in Algerien. *Ibid.*, pp. 661-663. [1907.]

5209. **Mendel, J.** Die Organisation und Gliederung des deutschen Petroleumhandels im letzten Decennium. *Petroleum Zeitschr.*, bd. ii, pp. 701-704, 756-759, 800-807. [1907.]
5210. ——— Internationale Petroleumstatistik, 1909.
5211. ——— Die Wirtschaftlichen Grundlagen der galizischen Erdölindustrie und ihrer Absatzgebiete. *Petroleum Zeitschr.*, bd. v, pp. 687-691. [1910.]
5212. ——— Die Petroleumschätze der Welt und ihre Verteilung. *Ibid.*, bd. vi, pp. 962-971. [1911.]
5213. ——— Das Holzöl und die Kriegsmarinen. *Ibid.*, pp. 2293-2301. [1911.]
5214. **Mendel, J., and P. Schwarz.** Die Kapitalsinvestitionen in der rumänischen Petroleumindustrie in ihrer geschichtlichen Entwicklung. *Petroleum Zeitschr.*, bd. ii, pp. 1001-1012. [1907.]
5215. **Mendeleev, D. I.** [Production of Kerosene, Paraffin and other Illuminating Mineral Matter.] *Rep. Paris Univ. Exhib.*, 1867, pt. 1, pp. 73-109.
5216. ——— [Principles of Chemistry.] Ed. v. *St. Petersburg*, 1889.
5217. ——— [On the American Petroleum Industry and its Relation to the Caucasian.] *Zap. Imp. Russk. Tekhn. Obsch.*, g. xi, otd. 1, pp. 331-396. [1877.]
5218. ——— [On the Origin of Petroleum.] *Jurn. Russk. Fiz. Khim. Obsch.*, t. ix, otd. 1, pp. 36, 37. [1877.]
5219. ——— [The Oil Industry of North America.] *St. Petersburg*, 1878.
5220. ——— [Results of Recent Travel in the Caucasus to Study the Present State of the Petroleum Industry.] *Jurn. Russk. Fiz. Khim. Obsch.*, t. xii, otd. 1, pp. 308, 309. [1880.]
5221. ——— [Report of Commission on Lamps for Burning Heavy Intermediate Oils.] *Ibid.*, pp. 361-363. [1880.]
5222. ——— [Baku Petroleum.] *Ibid.*, t. xiii, pp. 454-456. [1881.]
5223. ——— [Remarks on the preceding paper of Markovnikov and Ogloblin (5081).] *Ibid.*, t. xiv, pp. 54-56. [1882.]
5224. ——— [Heats of Combustion of Hydrocarbons.] *Ibid.*, t. xiv, pp. 230-238. [1882.]
5225. ——— [On new methods of Fractional Distillation with Baku Petroleum.] *Ibid.*, t. xv, otd. 1, pp. 189-194. [1883.]
5226. ——— [On the Origin of Petroleum.] *Ibid.*, pp. 367-380. [1883.]
5227. ——— [On the Baku-Batum Oil Pipe-lines.] *Zap. Imp. Russk. Tekhn. Obsch.*, g. xix, Trudi, otd. 1, pp. 131-153. [1885.]
5228. ——— [Examination of American Petroleum.] *Bull. Soc. Chim. Paris*, sér. 2, t. xliii, pp. 109, 110. [1885.]
5229. ——— [Baku Petroleum Industry, 1886.] Pp. 139-8vo, *St. Petersburg*, 1887.
5230. ——— The present Position and Prospects of the Caucasian Petroleum Industry. *Journ. Soc. Chem. Ind.*, vol. viii, pp. 753-757. [1889.]
5231. ——— [Supposed Exhaustion of the Baku Oil-field.] *Sievern. Vjestn.*, 1889, no. 10, pp. 23-35.
5232. ——— [The Petroleum Industry.] Ed. ii, pp. 203-295 of "Industry and Commerce of Russia." 8vo, *St. Petersburg*, 1896.
5233. ——— [Principles of Manufactures and Industries.] Tch. I [Fuel.] 8vo, *St. Petersburg*, 1897.
5234. **Méne, C.** Analyse des schistes bitumineux situés dans le Bugey près Belley, Ain. *Bull. Soc. Chim. Paris*, t. ii, pp. 137, 138. [1860.]
5235. **Mengoot, A.** Du pétrole et de sa distribution géographique dans le monde. *Compt. Rend. Congr. Nat. Soc. Franç. Géogr.*, sess. xvi, pp. 334-353. [1896.]
5236. **Mennell, J. L.** Oil in Mexico. *Mining Mag.*, vol. ii, pp. 448-450. [1910.]
5237. **Mennicke, H.** Beiträge zum Verhalten der Petroleumabfallschwefelsäure und ihre Verwendung in der Superphosphatfabrikation. *Zeitschr. angew. Chem.*, bd. xiii, pp. 1031-1034. [1900.]
5238. **Meusel, E.**, see Gill, C. H.
5239. **Mentzsch, P. W. S.**, see Stuart-Mentzsch, P. W.
5238. **Mentzel, —.** Der IX Internationalen Geologenkongress in Wien. IV. Boryslaw. V. Schodnica. *Gluckauf*, Bd. xxxix, pp. 1073-1085, 1101-1105. [1903.]
5239. **Mercanton, —.** Découverte d'une mine d'Asphalte aux environs d'Orbe. *Act. Soc. Helv. Sci. Nat.*, 1855, p. 101.
5240. **Merrill, F. J. H.** Mineral Resources of New York State. *Bull. N. Y. State Mus.*, vol. iii, pp. 365-595, 2 maps, 1895.
5241. ——— Valuation of Oil Properties. *Los Angeles Mining Rev.*, Sept. 24, 1910.
5242. **Merrill, G. P.** Guide to the Study of the Collections in the section of Applied Geology—the non-metallic Minerals [U.S. National Museum]. *Ann. Rep. Smithsonian Inst.*, 1898-1899, pp. 156-483. [1901.]
- Merrill, G. P.**, see Emmons, S. F.
5243. **Merrill, R. S.** Explosions and method of testing Petroleum Oil. *Amer. Chem.*, vol. vii, pp. 121, 122. [1876.]
5244. **Merrivale, W.** Occurrences and Mining of Manjak in Barbadoes, West Indies. *Trans. Fed. Inst. Eng.*, vol. xiv, pp. 539-546; vol. xvi, pp. 33-36. [1898.]
5245. **Merten, C.** Soziale Fürsorge im rumänischen Petroleumgebiet. *Petroleum Zeitschr.*, bd. ii, pp. 477-480. [1907.]
5246. **Merz, J.** Das gegenwärtige Stand der Ceresinindustrie. *Chem. Rev. Fett- Harz-Ind.*, bd. i, no. 5, pp. 4, 6. [1894.]
5247. **Messner, H.** Bitumen und Asphalt. *Die Natur*, bd. i, pp. 231-234, 244-246, 256-258. [1901.]
5248. **Méthérie, J. C. de la** Mémoire sur un Bitume élastique trouvé dans le Derbyshire. *Journ. Phys.*, t. xxxi, pp. 311-313. [1787.]
5249. ——— Théorie de la Terre. 3 Tt. 8vo, Paris, 1795.
5250. **Metzger, —.** Zement-Macadam, Asphaltierung und Holzpflaster. *Asphalt-Teerind.-Zeit.*, bd. iv, pp. 19, 20. [1904.]
5251. **Meunier, E. S.** Analyse de la Météorite de Mihal (Russie); présence d'une combinaison non signalée jusqu'ici dans les météorites [ozokérite et kabaite]. *Compt. Rend.*, t. cix, pp. 976, 977. [1889.]
5252. ——— Observations sur quelques roches asphaltiques et sur l'origine de l'asphalte. *Ibid.*, t. cxxiii, pp. 1327-1329. [1896.]
5253. ——— Étude stratigraphique et chimique sur les Gisements asphaltiques du Jura. *Bull. Soc. belge Géol.*, t. xii, pp. 75-100. [1900.]
- Meunier, E. S.**, see Dollfus, G.
5254. **Menschén, A.** Ueber die Anwendung von Sprengstoffen in der Bohrtechnik im Bakuer Naphtarayan. *Riga. Industr.-Zeit.*, bd. xxv, pp. 214, 215. [1908.]
5255. **Meyer, —.** Note sur la Cire fossile. *Compt. Rend.*, t. i, p. 283. [1835.]
5256. **Meyer, —.** Ueber Erdöl. *Meyer's Conversations-Lexicon*, bd. viii, pp. 261-266.
5257. **Meyer, E.** Die Beurteilung des Kreisprozesse von Wärmekraftmaschinen mit besonderer Berücksichtigung des Diesel-Motors. *Zeitschr. Ver. deutsch. Ing.*, bd. xii, pp. 1108-1114. [1897.]
5258. ——— Versuche am Diesel-Motor. *Zeitschr. Ver. deutsch. Ing.*, bd. xvii, pp. 637-639, 660-673. [1903.]
5259. ——— Versuche an Spiritusmotoren und am Diesel-Motor. *Mittb. Forsch. Ver. deutsch. Ing.*, h. 17, pp. 1-52. [1904.]
5260. **Meyer, E. H.** Minerbetriebe in Japan. *Oesterr. Zeitschr. Berg-Hüt.*, bd. lix, pp. 479-481. [1911.]
5261. **Meyer, L.** Ueber die Kohlenleucht Darstellung der Paraffine. *Ber. deutsch. chem. Ges.*, bd. xxvi, pp. 2070-2081. [1893.]
5262. ——— Ueber die Darstellung der Paraffine. *Ibid.*, bd. xxvii, pp. 2766, 2767. [1894.]
5263. ——— Die niederen Paraffine; Aethan und Propan. *Ibid.*, pp. 2767-2769. [1894.]
5264. **Meyer, M.** Ueber das Befreien des Brennoils von der zur Reinigung zugesetzten Schwefelsäure. *Journ. techn. Chem.*, bd. xvii, pp. 87, 88. [1833.]

5265. Meyer, R. Laboratoriums-Notizen. 6. Gypsgehalt von Asphaltstein. *Ber. deutsch. chem. Ges.*, bd. xxxvi, p. 2982. [1903.]
5266. Meyer, V. Gutachten betreffend eine Verordnung über den Verkehr mit Petroleum, Neolin, und anderen feurgefährlichen Flüssigkeiten. *Zürich*, 1879.
5267. Meyer, V., and P. Jacobson. Lehrbuch der organischen Chemie. *Leipzig*, 1893-190-.
5268. Meyer, V., and A. Münch. Ueber ein exactes Verfahren zur Ermittlung der Entzündungstemperatur brennbaren Gasmischungen. *Ber. deutsch. chem. Ges.*, bd. xxvi, pp. 2421-2432. [1893.]
5269. Meyerheim, G. Über die Veränderung des Asphaltgehaltes dunkler Mineralöle. *Chem.-Zeit.*, bd. xxxiv, pp. 454, 455 *Mitt. k. Mat.-prüf.-Amt.*, bd. xxix, p. 184. [1910, 1911.]
5270. ——— Die Veränderlichkeit des Asphaltgehaltes dunkler Mineralöle. *Chem. Rev. Fett-Harz-Ind.*, bd. xix, pp. 28, 29. [1912.]
- Meyerheim, G., see Marcusson, J.
5271. Meyn, L. Holsteinische Geschichte. *Kiel*, 1846.
5272. ——— Ueber das Asphalt-Vorkommen im Granit. *Ber. deutsch. nat. Vers.*, 1846, pp. 228-232.
5273. ——— Der Asphalt. *Halle*, 1872.
5274. ——— Ueber nordwestdeutsche Fundorte von Petroleum. *Ber. 51 Verst. deutsch. Nat.*, 1876.
5275. ——— Die Holsteinische Oelgrube bei Heide in Dithmarschen, mit einer graphischen Tiefenschichten-Darstellung. *Litho. MS. Itzehoe*, 1876.
5276. ——— Ueber die Petroleum-Fundorte in der Umgebung Hamburgs. *Verh. Nat. Ver. Hamburg*, 1876.
5277. Meyn, R. A. Die Oelkreide bei Heide in Holstein. *Litho. MS.* 1883.
5278. Meyrac, V. Notice sur les propriétés physiques et chimiques du bitume et les avantages qu'il peut offrir aux arts. *Journ. Phys.*, t. xciv, pp. 128-139. [1822.]
5279. ——— Sur le bitume de Bastenne et sur ses usages. *Bull. Soc. Philom. Paris*, 1822, pp. 46, 47.
5280. Miacynski, P. [Geology of Borslaw.] *Bergmann. Kongr. Krakau*, 1907.
5281. Michaelis, —. Ueber das Vorkommen von Steinkohlen, Petroleum und Gold im nordwestlichen China. *Verh. nat. Ver. preuss. Rheinl.*, bd. ix, Corr. Blatt., pp. 69-80. [1882.]
5282. Michaelov, N. [Search for Petroleum in Turkestan.] *Gorn. Journ.*, 1895, t. 3, pp. 275-279.
5283. Michalsky, A. [Geological Explorations in the S.E. part of the Kielez Government.] *Bull. Com. Geol. Russe*, t. vi, pp. 351-419. [1887.]
5284. Michel, R. Zur Beurteilung der Schmieröle nach ihrem Schmierwert. *Petroleum Zeitschr.*, bd. vi, pp. 2238-2243. [1911.]
5285. Michel-Levy, A. Sur les sondages profonds de Charmoy (Creusot) et de Macholles, près Riom (Limagne). *Compt. Rend.*, t. cxxii, pp. 1503-1506. [1896.]
5286. Michell, J. Report for the years 1887, 1888, on the Trade of St. Petersburg. *Dipl. Cons. Rep.*, ann. ser., nos. 447, 564. [1889.]
5287. Michels, —. Die Schlagwetterexplosion auf dem Kaliwerk der Gewerkschaft Frisch Glück bei Eime im Bergrevier Hannover am 23 August 1904. *Zeitschr. Berg-Hüt. Salinenw.*, bd. liii, Abh. pp. 564-573, pl. 1. [1904.]
5288. ——— Die deutsche Erdölindustrie. *Glückauf*, bd. xli, pp. 421-431, 457-465. [1905.]
5289. Michotte, F. Connaissances pratiques pour conduire les Automobiles à pétrole et électriques; suivies du nouveau règlement. 8vo, *Paris*, 1899.
5290. Mickle, G. R. Mineralogical Notes on Sudbury Anthracite. *Proc. Canad. Inst.*, ser. 4, vol. 1, pp. 64-66. [1898.]
5291. ——— The Kent Gas Field. *Ann. Rep. Bur. Mines Ontario*, vol. xix, pp. 149-153, 1 map. [1910.]
5292. Micksch, J. Ueber das Vorkommen des Retin-asphalts und des Bieglanzes in der Steinkohlenformation bei Pilsen, nebst einer geognostischen Skizze. *Corr.-Bl. zool.-min. Ver. Regensb.*, 1847, pp. 70-79.
5293. Mickwitz, A. Bericht über den Gasbrunnen auf Koksbr. *Bull. Ac. Imp. Sci. St. Petersburg*, sér. 6, 1908, pp. 188-190.
5294. Middellberg, E. Bijdragen mit het Scheikundig Laboratorium van het Hoofdbureau van het Mijnwesen in Nederlandsch-Indie te Batavia. *Jaarb. Mijnw. Ned. O. Ind.*, dl. 28, Wet., pp. 95-101. [1899.]
5295. Mieg, M. Note sur l'exploitation du Bitume en Alsace. *Bull. Soc. Industr. Mulhouse*, t. liii, pp. 83-90. [1883.]
5296. ——— Note sur le sondage d'Oberkutzenhausen. près Pechelbronn. *Ibid.*, t. lxxv, pp. 107-114, 148. [1895.]
- Mieg, M., see Zundel, C.
5297. Mikhailovski, G. P. [Geological Researches in 1905 in the Little Tchetchna, Terek.] *Bull. Com. géol. Russ.*, t. xxiv, pp. 427-456. [1905.]
5298. ——— [Origin of the Caucasian Petroleum.] *Ibid.*, t. xxv, pp. 319-360. [1906.]
5299. Mikucki, L. Eine neue Bohrmethode. *Naphta*, bd. ix, pp. 343-346 [1901.]
5300. ——— Für und wider das Spülbohrsystem. *Petroleum Zeitschr.*, bd. ii, pp. 225-228. [1906.]
5301. Miles, —. Report on the Trade of the Persian Gulf for 1885. *Dipl. Cons. Rep.*, ann. ser., no. 29. [1886.]
5302. Milkowsky, P. [On the examination of Caucasian Oils.] *Journ. Russk. Fiz. Khim. Obsch.*, t. xvii, otd. 2, pp. 37, 38. [1885.]
5303. Mill, N. Earthy Bitumen, called Murindo. *Quart. Journ. Sci.*, ser. 2, vol. iii, pp. 387, 388. [1828.]
- Miller, A. K., see Armstrong, H. E.
5304. Miller, A. W. Cosmoline and Paraffine Ointment. *Amer. Journ. Pharm.*, ser. 4, vol. iii, p. 534. [1872.]
5305. ——— Paraffine, Cosmoline, and Vaseline. *Ibid.*, vol. iv, p. 1. [1874.]
5306. Miller, J., and G. Miller. Decoloration and Purification of Paraffine. *Chem. News*, vol. xxxi, p. 175. [1875.]
5307. Miller, J. L. Petrol Engine Testing. *Trans. Glasgow Techn. Coll. Sci. Soc.*, 1909.
5308. Miller, L. H. [Fossil Birds] from the Quaternary Asphalt-Beds of Rancho la Brea, near Los Angeles. *Bull. Geol. Univ. Calif.*, vol. v, pp. 285-289, 305-317, pl. xv [1909]; pp. 438-448; vol. vi, pp. 1-19. [1910.]
5309. Miller, Th. D. The Recently Developed Oil-Field of Texas. *Eng. Min. Journ.*, vol. lxxv, pp. 734, 735. [1898.]
5310. ——— The Texas Oil Fields (Western Gas Assoc.). *Amer. Gas Light Journ.*, vol. lxxxiii, pp. 86-91. [1905.]
5311. Miller, W. G. The Limestones of Ontario. *Rep. Bureau Mines, Ontario*, vol. xiii, pt. 2. Pp. 143, 22 pls. [1904.]
5312. Miller, W. H. Electrolysis of Oil Pipes. *Electr. World.*, vol. iv, pp. 1667, 1668. [1910.]
5313. Millet, —. [Remarks on Bituminous Deposits of the Ain, Savoy, and Switzerland.] *Bull. Soc. Géol. France* (ser. 1), t. xi, pp. 352-354. [1840.]
5314. Mills, E. J. Destructive Distillation: a Manualette of the Paraffin, Coal-tar, Rosin, Oil, Petroleum, and Kindred Industries. 8vo, *London*, 1877.
5315. Millward, R. H. [Petroleum in the Americas.] *Bull. Pan-Amer. Union*, Nov. 1910.
5316. Milne, J. Notes on the Physical Features and Mineralogy of Newfoundland. *Quart. Journ. Geol. Soc.*, vol. xxx, pp. 722-745. [1874.]
5317. Milton, J. T. Diesel Engines for Sea-going Vessels. *Trans. Inst. Naval Arch.*, vol. liii, pl. 1, pp. 53-102. [1911.]
5318. ——— The Diesel Engine for Marine Power. A Survey of Requirements and Possibilities. *Gas and Oil Power*, vol. vi, pp. 159-162, 183-187. [1911.]



5319. **Minard, F. H.** Californian Asphaltum Industry. *Min. Ind.*, vol. xii, pp. 28-34. [1904.]
5320. **Miroca, C. R.** [The Oil Region of Vulcana, Rumania.] *Monit. Ind. Pétrol. Roum.*, t. ii, 1901.
5321. — [Raminicu Sarat Oilfield.] *Ibid.*, pp. 355-362. [1901.]
5322. — [Valea Gardului, Prahova, Oilfield.] *Ibid.*, pp. 472-475. [1901.]
5323. — [Grozesti Oil Field, Bacau.] *Ibid.*, t. v, pp. 407-409. [1904.]
5324. — [Water in Boreholes.] *Ibid.*, t. vii, pp. 121-125. [1906.]
5325. — Distribuțiunea geografică a petrolului în țara noastră. *Boll. Soc. Geogr. Româna*, t. xxvii, pp. 129-156. [1906.]
5326. — Étude technique et économique concernant la région pétrolière d'Apostolake, Tissa et Singer, District de Prahova [Roumaine]. *Journ. Pétrol.*, t. vi, pp. 197-199, 231-233. [1906.]
5327. — Remarques sur l'Origine et la Manière d'Être du Pétrole dans la Terre, résultantes des travaux exécutés à Moreni. *Compt. Rend. Congr. internat. Pétrole*, sess. 3, t. ii, pp. 173-186. [1910.]
5328. **Miroca, C. R., and G. A. Filiti.** Petroleul. Studiu Științific și Economic. 8vo, Bucharest, 1898.
5329. **Mirecki, J.** Ueber Verbesserung der Schnecke. *Naphtha*, bd. ix, p. 390. [1901.]
5330. **Miron, F.** Les Huiles Minérales. Pétrole, Schiste, Lignite. 8vo, Paris, 1897.
5331. **Misson, F. M.** Nouveau Voyage d'Italie. 12mo, Hague, 1694.
5332. **Mitchell, C. A.** The Water [and Asphalt] of the Dead Sea. *Knowledge*, vol. xxiv, pp. 259, 260. [1901.]
5333. — Oil: Animal, Vegetable, Essential and Mineral. 8vo, London, 1910.
5334. **Mitchell, J.** The General and Local Effects of Paraffin Oil upon those working in it. *Med. News*, Aug. 1888, p. 152.
5335. **Mitchell, K. M.** Kansas Oil (Western Gas Assoc.). *Amer. Gas-Light Journ.*, vol. lxxxiii, pp. 84-86. [1905.]
5336. **Mitchell, L. H.** Ras Gensah and Gebel Zeit. Report on their Geology and Petroleum. *Geol. Surv. Egypt*, 1877.
5337. **Mitchell, W. F.** The Commerce and Industries of Japan. *Journ. Soc. Arts.*, vol. liv, pp. 125-136. [1905.]
5338. **Mitscherlich, E.** Lehrbuch der Chemie. *Berlin*. Ed. ii, 1834.
5339. **Mitte, M. F.** [Gas and Oil Engines] *Gorn. Journ.* 1881, t. 1, pp. 163-210, 331-334; t. 2, pp. 269-293.
5340. — [Gas and Petroleum Engines.] *Zap. Imp. Russk. Tekhn. Obsch.*, g. xxiii, Jul., pp. 1-26, 2 pls. [1889.]
5341. **Mittler, H., and R. Lichtenstein.** Transparente und milchige Paraffine. *Chem. Rev. Fett-Harz-Ind.*, bd. xiii, pp. 104, 105. [1906.]
5342. **Mittler, H., and L. Neustadtl.** Apparat zur kontinuierlichen Ermittlung des spezifischen Gewichtes von Destillaten in Fabriksbetriebe. *Chem.-Zeit.*, bd. xxx, pp. 1023, 1024. [1906.]
5343. **Mitzakis, J.** The Russian Oil Fields and Petroleum Industry. 8vo, London, 1911.
5344. **Mitzakis, M.** The Chatma [Tchatma, Tiflis] Oil Field, its History and Development. *Petrol. World.*, vol. viii, pp. 490-492. [1911.]
5345. **Mitropoulos, K.** Die Eruption der Pechquellen von Kerl in Zante und ihre vulkanische Natur. *Petrol. Mitt.*, bd. xlii, pp. 156-161. [1896.]
5346. **Moddy, J.** The Truth about the Trusts. 1905.
5347. **Möller, F. W.** Die Versorgung der Welt mit Petroleum, mit besonderer Berücksichtigung Deutschlands. *Petroleum Zeitschr.*, bd. v, pp. 1145-1163, 1229-1237, 1304-1318, 1369-1387, 1437-1454, 1521-1525; bd. vi, pp. 15-19. [1910.]
5348. **Möller, V. v.** [Reports of the Mining Administration of the Caucasus, 1885-1889.] 8vo, Tiflis, 1886-1890.
5349. — [Caucasian Mineral Localities.] *Mat. Geol. Kawk.*, ser. 2, kn. iii, pp. vi, 420. [1889.]
5350. — [Economic Minerals and Waters of the Caucasus. Supplement I.] *Ibid.*, kn. iv, pp. 1-75. [1890.]
5351. **Moens, J. C. B.** Onderzoek eener Aardolie voorkomende in de Zuid- en Ooster-Afdeeling van Borneo tusschen Lampeen en Priengin. *Tijdschr. Nijverh. Landb.*, dl xi, pp. 364-368. [1865.]
5352. **Mörtstetdt, S. F.** Om förekomst af grufgas, metylvåste, i Norra Sundsgrufvan vid Gammelskroppa i Vermland. *Geol. Foren. Stockh. Forh.*, bd. i, pp. 22-24. [1889.]
5353. **Möser, L. W.** Petroleumprober. *Gewerbbl. Heft*, bd. xxxiii, pp. 94, 95. [1870.]
5354. **Moffat, Dr. R. C.** On the Bituminous Deposits of the Valley of the Pescara, South Italy. *Chem. News*, vol. xxx, p. 255. [1874.]
5355. **Mofras, Dufot** de. Exploration du Territoire de l'Orégon, des Californies, et de la Mer Vermelle exécutée pendant les Années 1840. 1841 et 1842. 2 Tt. 8vo, Paris, 1844.
5356. **Mohr, H.** Ueber die Wirtschaftlichkeit der Petroleumbeleuchtung. *Petroleum Zeitschr.*, bd. ii, p. 508. [1906.]
5357. — Beiträge zur Frage der Entstehung des Erdöles. *Petroleum Zeitschr.*, bd. vi, pp. 2069, 2070. [1911.]
5358. **Mohr, O.** Ueber die Frage; Welche Erfahrungen liegen vor mit der Ersetzung des teuren Benzins durch andere Brennstoffe für Motorzüge? *Zeitschr. angew. Chem.*, bd. xx, pp. 1927, 1928. [1907.]
5359. **Moisan, C.** Memoria sobre los productos bituminosos de la Isla de Cuba. *Diario de la Marina*, 1857.
5360. **Moissan, H.** Sur la formation des carbures d'hydrogène gazeux et liquides par l'action de l'eau sur les carbures métalliques. *Compt. Rend.*, t. ccxii, pp. 1462-1467. [1896.]
5361. — Sur la Présence de l'Argon, de l'Oxyde de Carbone et des Carbures d'Hydrogène dans les Gaz des Fumerolles du Mont Pelé à la Martinique. *Ibid.*, t. cxxxv, pp. 1085-1088. [1902.]
5362. — Traité de Chimie Minérale. 8vo, Paris, 1904-1906
5363. **Mojon, G.** Descrizione mineralogica della Liguria. 8vo, Genova, 1805.
5364. **Molinari, E., and P. Fenaroli.** Eine neue Reaktion des Petroleums [Ozonisation]. *Ber. deutsch. chem. Ges.*, bd. xli, pp. 3704-3707. [1908.]
5365. **Molinari, F.** Combustibili industriali e petrolio. 16mo, Milan, 1892.
5366. **Molo, D., see Zolesi, D.**
5367. **Molon** — de. Étude sur les tourbes des terrains cristallisés du Finistère. *Compt. Rend.*, t. xcii, pp. 139-142. [1881.]
5368. **Molon, F.** Sopra gli scisti bituminosi esistenti nell'Alta Italia sotto tutti i rapporti scientifici ed industriali. *Atti R. Ist. Ven. Sci.*, ser. 3, vol. xi, pp. 25-91. [1865.]
5369. **Monke, A., and F. Beyschlag.** Ueber das Vorkommen des Erdöls. *Zeitschr. prakt. Geol.*, bd. xiii, pp. 1-5, 65-69, 421-426. [1905.]
5370. **Monkman, W. T.** New Zealand, Oil and Coal Deposits in Southland. *Board of Trade Journ.*, vol. lxx, p. 502. [1910.]
5371. — New Zealand, Shale, Gold, and Scheelite Discoveries. *Ibid.*, vol. lxxiii, p. 42. [1911.]
5372. **Monnet, A.** Application de la paraffine au graissage des machines à haute température. *Cosmos*, sér. 3, t. i, Dec. 7, pp. 16, 17. [1867.]
5373. **Montag, F.** Das Slaryer Naphthagebiet im Goricler Kreise Mittelgaliziens, und seiner geologischen Verhalten. *Berg. Hutt. Zeit.*, bd. xlii, pp. 205-207. [1882.]
5374. — Ueber den Exocentermeissl. *Naphtha*, bd. x, pp. 235, 236. [1902.]

5374. **Montague, G. H.** The Rise and Progress of the Standard Oil Company. 12mo, *New York*, 1904.
5375. **Montaigne, M. de.** Journal des Voyages en Italie par voie de la Suisse et de l'Allemagne en 1580 et 1581. 158-.
5376. **Monteiro, J. J.** Angola and the River Congo. 2 vols. 8vo, *London*, 1875.
5377. **Montesquieu, J. B. S. de.** Observations de Physique et d'Histoire Naturelle sur les Eaux Minérales des Pyrénées. 1750.
5378. **Montgomerie, J.** The Arrangement and Construction of Oil Vessels. *Cassier's Mag.*, vol. xl, pp. 737-752. [1911.]
5379. **Montgomery, A.** Report on the Country between Mole Creek and the Mount Dundas Silver Field, and on the Discovery of Coal at Barn Bluff. *Rep. Sec. Mines Tasmania*, 1892-1893, p. 9. [1893.]
5380. **Montgruel, L. P.** Traité pratique industriel et commercial des Huiles minérales, à l'usage des fabricants, marchands et consommateurs, des pétroles schistes et autres huiles analogues. *Paris*, 1864.
5381. **Moore, C.** [On Experiments testing the Comparative Value of the Mersey Schist, and of the Coals from Schouten Island and the Douglas River.] *Proc. R. Soc. Van Diemen's Land*, vol. iii, pp. 177, 178. [1855.]
5382. **Moore, R. T.** The Mineral Oil Industry of Scotland. *Trans. Fed. Inst. M. Eng.*, vol. iv, pp. 36-47. [1893.]
5383. **Moore, W.** Report for 1894 on the Trade of San Francisco. *Dipl. Cons. Rep.*, ann. ser., no. 1576. [1895.]
5384. **Morand, S. F.** L'Art d'Exploiter les Mines de Charbon de Terre. *Paris*, 1768.
- Moravski, T.**, see **Demski, H.**
5385. **More, R.** . . . [Curious Remarks in his Travels through Italy.] *Phil. Trans.*, vol. xvi, pp. 464-466. [1750.]
5386. **Moreau, G.** Les Moteurs à Explosion. Étude à l'usage des constructeurs et conducteurs d'automobiles. 8vo, *Paris*, 1900.
5387. ——— Note sur le régime des moteurs à explosion (moteurs à quatre temps). *Ann. Mines*, ser. 9, t. xx, pp. 203-269. [1901.]
5388. **Moreno, F.** El Petroleo del Peru. *Lima*, 1891.
5389. **Morgan, J. de.** Note sur les gîtes de Naphte de Kend-é-Chirin (gouvernement de Ser-i-Poul). *Ann. Mines*, ser. 9, t. i, pp. 227-238. [1891.]
5390. ——— Mission Scientifique en Perse. T. iii, Partie I, Études géologiques. Géologie Stratigraphique. 4to, *Paris*, 1905.
5391. **Morgan, T. M.** Researches on the Paraffins existing in Pennsylvania Petroleum. *Journ. Chem. Soc.*, vol. xxviii, pp. 301-307. [1875.]
- Morgan, T. M.**, see **Schorlemmer, C.**
5392. **Morgan, W.**, and **E. B. Wood.** Carburettor Action. *Proc. Inst. Automob. Eng.*, n.s., vol. v, pp. 37-82. [1911.]
5393. **Morgan, W. C.** The Origin of Bitumen. *Amer. Geol.*, vol. xxxv, pp. 46-50. [1905.]
5394. **Morgan, W. C.**, and **M. C. Tallmon.** A Peculiar Occurrence of Bitumen and Evidence as to its Origin. *Amer. Journ.*, ser. 4, vol. xviii, pp. 363-377, pls xviii, xix. [1904.]
5395. ——— A Fossil Egg from Arizona. *Bull. Univ. Geol.*, vol. iii, pp. 403-410, pls. xlviii, xlix. [1904.]
5396. **Morichini, D.** Sopra il gaz infiammabile del Tevere. *Giorn. Acad. Sci.*, vol. viii. [1820.]
5397. **Morier, Jas.** Journey through Persia, Armenia, and Asia Minor, to Constantinople in the years 1808 and 1809; in which is included some account of the Proceedings of the Missions under Sir Harford Jones to the Court of the King of Persia. 4to, *London*, 1812.
5398. ——— A Second Journey through Persia to Constantinople between the years 1810-16. *London*, 1818.
5399. **Morison, J.** The Danger attending the Use of Light Mineral Oils for Lubricating Air-compressing Machinery. *Trans. N. Engl. Inst. Eng.*, vol. xxxviii, pp. 3-12. [1891.]
5400. **Morosevitch, I.** [Analyses of Mud of the Enikale Mud-Volcano (Ketchik) and of the Waters associated with Petroleum of Kudako (Kuban).] *Varsavsk. Univ. Izv.*, 1888, no. 3, pp. 1-8.
5401. ——— Ueber Hatchettin von Bonarka bei Krakau. *Bull. Acad. Sci. Cracoe*, 1908, pp. 1067-1072.
5402. **Morpurgo, G.** Ueber die Anwendung des flüssigen Brennstoffes "Liquid Fuel" als Brennmaterial für die Schiffe. *Oesterr. Chem.-Zeit.*, n.f., bd. v, pp. 653-655. [1902.]
5403. **Morris, D. F. van B.** Nota van toelichting op het contract, gesloten met het landschap Doerie (Maseurempoeloe) [Celebes] op den 30<sup>en</sup> September, 1890. *Tijdschr. Ind. Taal. Land. Volkenk.*, dl. xxxvi, pp. 164-177. [1893.]
5404. **Morris, E.** The Santa Maria Fields. *Oil Industry*, September 15, 1910.
5405. **Morris, G. C.** On Mineral Caoutchouc. *Proc. Ac. Nat. Sci. Philadel.*, ser. 3, vol. vii, pp. 131, 132. [1877.]
5406. **Morrison, G. J.** A Description of the Island of Formosa, etc. *Geogr. Mag.*, vol. iv, pp. 319-322. [1877.]
5407. **Morrison, W.** The Mineral Albertite, Strathpeffer, Ross-shire. *Min. Mag.*, vol. xi, pp. 101-103. [1884.]
5408. ——— The Mineral Albertite and the Strathpeffer Shales. *Trans. Edinb. Geol. Soc.*, vol. iv, pp. 307-310; vol. v, pp. 34-40. [1885.]
5409. ——— A New Mineral Tar in Old Red Sandstone, Ross-shire. *Ibid.*, vol. v, pp. 500, 501. [1888.]
5410. ——— Elaterite: a Mineral Tar in Old Red Sandstone, Ross-shire. *Min. Mag.*, vol. viii, pp. 133, 134. [1889.]
5411. **Morse, L. G. E.** The Mechanical and Thermal Efficiency of a Petrol Engine. *Proc. Inst. Automob. Eng.*, n.s., vol. lii, pp. 274-288. [1909.]
- Morse, L. G. E.**, see **Hopkinson, B.**
5412. **Morton, H.** Fluorescent Relations of Certain Solid Hydrocarbons found in Petroleum Distillates. *Journ. Franklin Inst.*, vol. lxxiv, pp. 269-373. [1872.]
5413. ——— Thallene, its Source, and the History of its Discovery. *Chem. News*, vol. xxxiv, pp. 188-190. [1876.]
5414. ——— [Prof. Sadtler's Gas Analyses.] *Proc. Amer. Phil. Soc.*, vol. xvii, pp. 722-724. [1878.]
5415. **Morton, H.**, and **W. E. Geyer.** Paraffins in Commercial Water-Gas. *Chem. News*, vol. xxxvii, pp. 187, 188. [1878.]
- Mory, A. V. H.**, see **Noyes, W. A.**
5416. **Moryakovski, —.** [Travels through Russia, Astrakhan, Derbent, Baku, Lenkoran, Enzeli, Amol, Ali.] *Repert. Panteon.*, 1852, nos. 9, 10.
5417. **Mosel, A.** [Transylvanian Salt-Mining.] *Ber. Versamml. ung. Nat. Aert.*, 1864, p. 177.
5418. **Moser, L. K.** Bergherter von Sistiana (Trieste). *Verk. k.-k. geol. Reichs.*, 1902, pp. 266, 267.
5419. **Mosler, C.** Katalog für die Sammlung der Bergwerk-, Hütten-, Salinen- und Steinbruch-Produkte von Elsass-Lothringen für die Wiener Weltausstellung, 1873.
5420. ——— Die Petroleum-industrie der Vereinigten Staaten von Nord-Amerika im Jahre 1876. *Halle*, 1876.
5421. **Moss, J.** Vaseline. *Pharm. Journ.*, ser. 3, vol. vi, pp. 623, 624, 661, 662. [1876.]
5422. **Moss, R. J.** An Irish Specimen of Dopplerte. *Proc. Roy. Dublin Soc.*, n.s., vol. x, pp. 23-100. [1903.]
- Mossner, C.**, see **Arends, H.**
5423. **Motley, J.** Report on the Geological Phenomena of the Island of Labuan and Neighbourhood. *Journ. Ind. Archipel.*, vol. vi, pp. 555-573. [1852.]

5424. **Mottura, S.** Sulla formazione terziaria nella Zona Solifera della Sicilia. *Mem. R. Com. geol. Ital.*, vol. i, pp. 49-140; 4 pls. [1871.]
5425. **Mougel, L.** Note sur le gisement de bitume fossile des environs de Zaho (Kurdistan). *Ann. Mines*, sér. 7, t. vii, pp. 85-91, pl. ill. [1875.]
5426. **Mounsey, J.** Concerning the Everlasting Fire in Persia [Baku]. *Phil. Trans.*, vol. xiv, pp. 296-300. [1748.]
5427. **Moureu, C.** Les Degagements gazeux des Sources Thermales. *Rev. Sci. Paris*, ser. 5, t. ix, pp. 353-361. [1908.]
5428. **Moureu, C.**, and **R. Biquard.** Nouvelles Recherches sur les Gaz rares des Eaux thermales. *Compt. Rend.*, t. cxlvi, pp. 435-437. [1908.]
5429. **Moussy, V. M. de.** Description géographique et statistique de la Confédération Argentine. 3 Tt. and Atlas. 8vo, Paris, 1860-1864.
5430. **Mrazec, L.** Contribution à l'étude de la depression subcarpathique. *Bull. Soc. Sci. Bucharest*, t. ix, 1900.
5431. ———. Distribuirea geologica a zonelor petrolifere in Romania. 4to, Bucharest, 1903.
5432. ———. [The Study of the Petroliferous Formation of Rumania. Report to the Minister of Public Domains on 25th March 1903, on the Petroliferous Region of Campina-Poliana.]
5433. ———. Presentul Sarmaticului la Colibasi in judetul Dambovitza. *Bull. Soc. Sci. Bucharest*, 1904.
5434. ———. Contribution à la géologie de la region Gura-Ocnitzel-Moreni. *Monit. Int. pétrol. Roum.*, t. vi, no. 28. [1905.]
5435. ———. Les plis a noyau de perocement. *Bull. Soc. Sci. Bucharest*, 1906.
5436. ———. Excursion à la Saline de Slanic. 8vo, Bucharest, 1907.
5437. ———. Revizuire in Masivul cristalin Mesozoic din Judetulin Suceava, si Cercetari in Regiunile petrolifere ale Subcarpatilor. *An. Inst. geol. Rom.*, t. i, pp. xciii-xcix. [1908.]
5438. ———. Roumanie: Esquisse géologique et minière. Bucharest, 1910.
5439. ———. Ueber die Bildung der rumänischen Petroleumlagerstätten. *Compt. Rend. Congr. internat. Pétrole*, sess. 3, t. ii, pp. 80-134. [1910.]
5440. ———. Die Erdöllagerstätten in Rumänien. *Org. Ver. Bohrtechn.*, bd. xviii, pp. 86-89, 112, 113, 126-128, 140, 141, 150-153, 174-176, 185-187, 196-198, 207-209, 220-223, 233-237. [1911.]
5441. **Mrazec, L.**, **V. Puscariu, L. Edeleanu, C. Halaceanu, C. Murgoci, C. Osiceanu, and V. Toroceanu.** Industria Petrolului din România in 1908. 8vo, Bucharest, 1909.
5442. **Mrazec, L.**, and **L. Teisseyre.** Ueber oligocäne Klippen am Rande der Karpathen bei Bacau (Moldan). Ein Beitrag zur Tektonik der rumänischen Karpathen. *Jahrb. k.-k. geol. Reichs.*, bd. li, pp. 235-246. [1901.]
5443. ———. Aperçu géologique sur les formations salifères et les gisements de sel en Roumanie. *Monit. Int. Pétrol. Roum.*, t. iii, nos. 43-51. [1902.]
5444. ———. Comunicare preliminară asupra structurii geologice a regiunii Câmpina-Busteniarii. *An. Acad. Rom.*, ser. 2, t. xxix, p. 20. [1906.]
5445. ———. Excursion dans les régions pétrolières de la vallée de la Prahova. 8vo, Bucharest, 1907.
5446. ———. Esquisse tectonique de la Roumanie. II. Stratigraphie des régions pétrolières de la Roumanie et des contrées avoisinantes. III. Esquisse tectonique des Subkarpathes de la vallée de la Prahova. Bucharest, 1907.
- Mrazec, L.**, see **Alimaestianu, C.**
5447. **Muck, J.** Ueber ein neues Petroleumterrain im Kaukasus. *Naptha*, bd. ix, pp. 407-409. [1901.]
5448. ———. Ueber Erdöl im 19ten Jahrhundert. *Berg-Hütt. Jahrb. Wien*, bd. i, pp. 117-148. [1902.]
5449. ———. Der Erdwachsbergbau in Boryslaw. Berlin, 1903.
5450. ———. The Petroleum Fields of Upper Italy. *Petrol. Rev.*, vol. ix, pp. 463, 514. [1905.]
5451. **Mudge, B. F.** The Iola Gas Well. *Trans. Kansas Ac. Sci.*, vol. v, 1877.
5452. **Müffelmann, L.** Ein Petroleummonopol in Deutschland. *Allgem. österr. chem.-techn. Zeit.*, bd. xxviii, pp. 131, 132. [1910.]
5453. ———. Die Petroleumindustrie Maikops. *Ibid.*, pp. 163, 164. [1910.]
5454. ———. Die Lage des deutschen Petrolenmmarkets im Jahre 1910. *Ibid.*, bd. xxix, pp. 33-37. [1911.]
5455. **Müller, —.** Beschreibung der in Tirol üblichen Art das Steinöl zu bereiten. *Abh. Privatges. Böhm.*, bd. v, p. 333. [1782.]
5456. **Müller, —.** Mineralölindustrie in der Provinz Sachsen. *Wirtl's Gewerkekalendar*, 1869, p. 18.
5457. **Mueller, B.** The Motor Boat and its Machinery Outfit. 12mo, Hanover, 1906.
5458. **Müller, C. E.** Die Paraffinfrage. *Die Natur*, bd. iv. [1855.]
5459. ———. Eine kritische Zusammenstellung der Methoden der Beinigung des Rohparaffins. *Polyt. Journ.*, bd. cliv, p. 227. [1859.]
5460. **Müller, C. J.** Untersuchung von Erdöl und Asphalt-sand. *Oesterr. Zeitschr. Berg-Hütt.*, bd. vii, pp. 182, 183. [1859.]
5461. **Müller, E.** Ueber pyrogene Zersetzung von Gasöl, Phenol und Kreosot. *Journ. prakt. Chem.*, bd. cxlvi, pp. 1-50. [1898.]
5462. **Müller, G.** Das Vorkommen von Petroleum in Westphalen. *Zeitschr. prakt. Geol.*, bd. xii, pp. 9-11. [1904.]
- Müller, H.**, see **De la Rue, W.**
5463. **Müller, J.** Ueber eine neue Einrichtung zur Aufbewahrung von Petroleum. *Archiv Pharm.*, bd. clxxvi, pp. 92-95. [1869.]
5464. ———. Versuche über Oxydation und Verseifung von Erdölen. *Chem.-Zeit.*, bd. xvi, pp. 1396, 1397. [1892.]
5465. **Müller, W.** [The Occurrence of Petroleum in Alsace and details of the Chemical and Physical properties of Pechelbron Oil.] *Allg. österr. Chem. Techn. Zeit.*, bd. xxiv, pp. 65, 66, 74, 75. [1906.]
- Münch, A.**, see **Meyer, V.**
5466. **Münzel, M.** Wasserversorgungen mit Gas-, Benzin- und Petroleummotorenbetrieb. *Zeitschr. Ver. deutsch. Ing.*, bd. xxxix, pp. 303-311. [1895.]
5467. **Muggia, A.** Short Note on the Petroleum Deposits in Italy. *1st Internat. Petrol. Congr.*, pp. 45, 46. [1900.]
- Muhlberg, M.**, see **Königsberger, J.**
5468. **Mukhin, B.** [Lubricants from Grozni Petroleum.] *Jurn. Russk. Fiz. Khim. Obsch.*, t. xxxiv, otd. 1, p. 850. [1902.]
5469. **Muldner, E.** [Progress of the Petroleum Industry.] *Diennik Pölsky*, 1878, no. 258.
- Muldoon, P.**, see **Fournel, H.**
5470. **Mulhauser, Dr. O.** Die chemische Industrie auf der Columbischen Weltausstellung im 1893. III. Erdölindustrie. *Polyt. Journ.*, bd. ccxc, pp. 111-120, 135-139. [1893.]
5471. ———. Ueber das im Trenton-kalksteine vorkommende Erdöl. *Ibid.*, bd. ccxcii, pp. 116-119. [1894.]
5472. **Muller, A.**, and **J. Mathei.** Éclairage au gaz de Napthe. *Gén. Ind.*, t. xxv, pp. 225-233. [1868.]
5473. **Muller, G. F.** Sammlung Russischer Geschichte. 9 Bde. 8vo, St. Petersburg, 1732-1764.
- Munier-Chalmas, E.**, see **Hébert, E.**
5474. **Munk, E.** Ueber Bohlfuehrungen. Vienna, 1910.
5475. **Munn, M. J.** Petroleum and Gas in Western Pennsylvania. *Rep. Penns. Geol. Surv.*, 1906-1908, pp. 266-306. [1908.]
5476. ———. Studies in the Application of the Anticlinal Theory of Oil- and Gas-Accumulation. *Econ. Geol.*, vol. iv, pp. 141-157. [1909.]
5477. ———. The Anticlinal and Hydraulic Theories of Oil- and Gas-Accumulation. *Ibid.*, pp. 509-529. [1909.]

5478. **Munn, M. J.** Geology of the Oil and Gas Fields of the Sewickley quadrangle, Penn. (Introd. by **I. C. White.**) *Rep. Penns. Geol. Surv.*, no. 1. Pp. 170, 9 pls. [1910.]
5479. ——— Geology of the Oil and Gas Fields of the Clarion quadrangle, Penn. *Idem*, no. 3. Pp. 111, 9 pls. [1910.]
5480. ——— Reconnaissance Report on the Fayette Gas Field. *Bull. Geol. Surv. Alabama*, no. 10. Pp. 66. [1911.]
5481. ——— Geology of the Oil and Gas Fields of the Carnegie quadrangle, Pennsylvania. *Bull. U.S. Geol. Surv.*, no. 456. Pp. 99; 5 pls. [1911.]
5482. ——— Preliminary Report upon the Oil and Gas Developments in Tennessee. *Bull. Tenn. Geol. Surv.*, no. 2, pp. 45. [1911.]
5483. ——— Sewickley, Pa. *Fo. 176, U.S. Geol. Surv.*, 1911.
- Munn, M. J.**, see **Grissold, W. T.**; and **Shaw, E. W.**
- Munoz, J. F. y.**, see **Franco y Munoz, J.**
5484. **Munro, J.** The Pitch Lake of Trinidad. *Argonaut*, 1875, pp. 34-42.
5485. **Munroe, C. E.** Petroleum Refining in the United States, *Census of Manufactures, 1905, U.S. Dept. Comm.*, *Bull.* no. 70.
5486. ——— Propagation of Explosion in mixtures of Vapour and Air in Tubes. *Proc. Amer. Phil. Soc.*, vol. xlix, pp. 203-206. [1910.]
5487. **Munroe, H. S.** The Mineral Wealth of Japan. *Trans. Amer. Inst. Min. Eng.*, vol. v, pp. 236-302. pl. v. [1877.]
- Muntz**, —, see **De la Loyère**, —.
- Muntz, A.**, see **Lé Bel, J. A.**
5488. **Murchison, R. I.** On the Bituminous Schist and Fossil Fish of Seefeld in the Tyrol. *Proc. Geol. Soc.*, vol. i, pp. 139, 140. [1829.]
5489. ——— The Silurian Rocks and Fossils of Norway, as described by M. Theodor Kjerulf; those of the Baltic Provinces of Russia by Professor Schmidt; and both compared with their British Equivalents. *Quart. Journ. Geol. Soc.*, vol. xiv, pp. 36-53. [1858.]
5490. ——— On the Succession of the Older Rocks in the Northernmost Counties of Scotland, with some observations on the Orkney and Shetland Islands. *Quart. Journ. Geol. Soc.*, vol. xv, pp. 353-421\*, pls. xii, xiii. [1859.]
5491. **Murdoch, J. V. B.** Notes on Brine and Oil Wells in Western China. *Trans. Inst. Min. Met.*, vol. ix, pp. 362-365, pl. xi. [1901.]
5492. **Mure, J. A.** Analyse de l'Eau du Puy de la Poix. *Compt. Rend. Assoc. Franç.*, sess. 5, pp. 1067-1069. [1875.]
- Murgoci, C.**, see **Mrazec, L.**
5493. **Murgoci, G. M.** Tertiary Formations of Oltenia with regard to Salt, Petroleum, and Mineral Springs. *Journ. Geol.*, vol. xiii, pp. 670-712. [1905.]
5494. ——— Tertiariul din Oltenia cu privire la Sare, Petrol si Ape Minerale. *Ann. Inst. Geol. Român.*, t. i, pp. 1-128; pls. i-v. [1907.]
5495. ——— [Setjar-Recea Oilfield.] *Revista Petrolului*, t. i, pp. 292-297. [1908.]
5496. ——— Die Petroleumlagerstätten von Balteni. *Compt. Rend. Congr. internat. Pétrole*, sess. 3, t. ii, pp. 407, 408. [1910.]
5497. ——— Das Facies und die Tektonik des Tertiäres von Oltenia in Bezug auf die Petroleumlagerstätten. *Ibid.*, pp. 409-414. [1910.]
5498. **Murray, A.** Geological Survey of Newfoundland. Report of Progress for the year 1874. 8vo, *St. John's*, 1875.
5499. **Murray, A. (2).** Report on the Trade of Batoum for the year 1891. *Dipl. Cons. Rep.*, ann. ser., no. 1027. [1892.]
5500. **Murray, David.** Petroleum, its History and Properties. *Trans. Albany Inst.*, vol. iv, pp. 149-166. [1862.]
5501. **Murray, J.** Naphtha in Coal. *Ann. Phil.*, vol. xvi, p. 466. [1820.]
5502. **Muschketov, V. I.** Les Richesses Minérales du Turkestan Russe. 4to, *Paris*, 1878.
5503. ——— [Turkestan. Geological and Orographical Account from Data collected 1874-1880.] 8vo, *St. Petersburg*, 1886.
5504. ——— [Appearance of an Island in the Caspian Sea, off Apsheron.] *Verh. russ.-k. Min. Ges.*, sér. 2, bd. xxix, pp. 245-248. [1892.]
- Muschketov, V. I.**, see **Romanovski, G.**
5505. **Muspratt, J. S.** Chemistry, theoretical, practical, and analytical, as applied and relating to the Arts and Manufactures. 2 vols. *Glasgow*, 1857.
5506. **Musschenbroeck, P. van.** Elementa Physicæ. 8vo, *Leyden*, 1734.
5507. ——— Introductio ad Philosophiam Naturalem. *Leyden*, 1762.
5508. **Mylius, F., F. Förster**, and **G. Schöne.** Untersuchung en über den Stahl. *Zeitschr. anorgan. Chem.*, bd. xiii, pp. 38-58. [1896.]
5509. **N** ———. Das Sundshensische Naphtagebiet im Nordkaukasus. *Chem.-Zeit.*, bd. xiv, p. 159. [1890.]
5510. **Nachmias, M.** L'Activité Optique du Pétrole. *Journ. Pét.*, t. x, pp. 161-163. [1910.]
5511. ——— [The Problem of the Illuminating Oils of Rumania.] *Rev. Petrolului*, 1911.
5512. **Nadel, S.** Anwendung des Rohöls bei Schmiedefeuerungen. *Naphtha*, bd. xvi, pp. 66-68. [1908.]
5513. **Nägel, A.** Die neue Entwicklung der ortfesten Oelmachine. *Zeitschr. Ver. deutsch. Ing.*, bd. lv, pp. 1318-1345. [1911.]
5514. **Nägel, H.** Nouveau procédé d'éjection de l'eau pour le forage des puits de mines et des sondages a grand profondeur et ses avantages auprès de sondages pour pétrole. *Journ. Pét.* t. ii, pp. 396-399, 425, 426. [1902.]
5515. **Nägel, O.** The Transportation of Gases, Liquids, and Solids. 8vo, *New York*, 1910.
5516. **Nakamura, T.** On the Cause of the Diminishing Flame in Lamps fed with inferior Kerosene. *Journ. Soc. Chem. Industr.*, vol. ii, pp. 535, 536. [1883.]
- Nakamura, T.**, see **Divers, E.**
5517. **Narcy, P.** Note sur le pétrole de Gabian. *Compt. Rend. Soc. Ind. Min.*, 1888, p. 50-54.
5518. ——— Les Bitumes. Définition. Bitumes proprement dits, Pyroschistes et Retinasphaltes. *Bull. Ecole Min. Lille*, 1889, p. 142.
5519. **Nasini, R.**, and **F. Anderlini.** Analisi chimica delle acque termale della sorgente del Monte Irone in Abano. *Gazz. Chim. Ital.*, vol. xxiv, pt. 1, pp. 327-342. [1894.]
5520. ——— Ricerca dell'argo nelle emanazione terrestri. I. Gas delle terme di Abano. *Ibid.*, vol. xxv, pt. 2, p. 508, 509. [1895.]
5521. **Nasini, R., F. Anderlini**, and **B. Salvadori.** Ricerche sulle emanazione terrestri italiane. *Mem. R. Acc. Linc.*, ser. 5, vol. ii, pp. 375-423; 7 pls: vol. v, pp. 25-82; 4 pls. [1897, 1905.]
5522. **Nasini, R.**, and **R. Salvadori.** Relazione sull'analisi del gaz combustibili di Salsomaggiore. *Gazz. Chim. Ital.*, ann. xxx, pp. 281-296. [1900.]
5523. **Nason, F. L.** The Economic Geology of Albany County (Geol. Surv. N. York). *Ann. Rep. N. York State Mus.*, vol. xivii, pp. 459-481, map. [1894.]
5524. **Nastyukov, A. M.** [Action of Formaline on Petroleum and its Distillation-Products.] *Jurn. Russk. Fiz. Khim. Obsch.*, t. xxxvi, pp. 881-898. [1904.]
5525. ——— [Fractionation by Precipitation, and Classification of Petroleum: A Reply to Kharitchkov.] *Ibid.*, pp. 1329-1332. [1904.]
5526. ——— [Binagadi Oil.] *Ibid.*, t. xxxvii, pp. 151, 152. [1905.]
5527. ——— Sur l'Action de la Formaline sur les Naphtes et Produits de leur Distillation. *Compt. Rend. Congr. internat. Chim. appl.*, sess. 6, t. iii, pp. 139-142. [1907.]
5528. ——— The Chemical Composition of the Lubricating Oils. *Ibid.*, sess. 7, t. iv, pp. 9-13. [1910.]

5529. **Nastyukov, A. M., and K. L. Malyarov.** [Action of Formaline on Petroleum Distillates: Formation of Liquid Condensation-Products.] *Journ. Russk. Fiz. Khim. Obsch.*, t. xxii, otd. 1, pp. 1596-1604. [1910.]
5530. **Natterer, K.** Oceanographical Results of the Austro-Hungarian Deep Sea Expeditions. [Read before Sect. E of British Association, 1898.] *Scott. Geogr. Mag.*, vol. xiv, pp. 636-642. [1898.]
5531. ——— *Chemische-geologische Tiefsee-Forschung. Geogr. Zeitschr.*, bd. v, pp. 190-209, 252-260. [1899.]
5532. ——— Ueber chemisch-geologische Arbeiten der "Pola" Expedition. *Verh. Internat. Geogr. Kongr.*, vers. vii, th. ii, pp. 326-333. [1901.]
5533. **Naumann, C. F.** Elemente der Mineralogie. 8vo, Leipzig, 1846.
- Naumov, S., see Zelinsky, N. D.**
5534. **Naus, —.** Verbrennung fester und gasförmiger Heizstoffe. *Journ. Gasbeleucht.*, vol. xlix, pp. 186-192. [1906.]
5535. **Nawratil, A.** Chemisch-technische Analysen der gasförmigen Erdöle. *Polyt. Journ.*, bd. ccxvii, pp. 328-334, 423-429. [1882.]
5536. ——— Ueber fossilen Kautschuk, genannt Helenit. *Ibid.*, bd. ccxviii, pp. 513-518. [1883.]
5537. **Neff, P.** Ueber die Gewinnung von Lampenschwarz aus natürlichen Kohlenwasserstoffen. *Ibid.*, pp. ccxxxii, pp. 177, 178. [1879.]
5538. **Negreiros, A.** Ile de San Thomé. 8vo, Paris, 1901.
- Nelson, G., see Gould, C. N.**
5539. **Nelson, L. R.** Prospects of Oil Production in Alabama. *Manufacturers' Record*, 1902.
5540. **Nendtvich, C. M.** Ueber eine chemisch-technische Untersuchung des Muraközer und Hagymadfalver Bergtheeres in Ungarn. *Ber. deutsch. Nat. Versamml.*, 1843, pp. 185-191.
5541. ——— Ueber den Bergtheer. *Ber. Freund. Nat. Wien*, bd. iii, pp. 271-274. [1847.]
5542. **Nerutchev, V. V.** [Oil-Industry of Transcaucasia.] *Priroda*, 1876, pp. 119, 120.
5543. **Neschel, —, and F. v. Kosechkul.** [Sketch of Holy Island in Commercial Respects.] *Zap. Kavk. Oud. Imp. Russ. Geogr. Obsch.*, t. vi, pp. 166-185. [1864.]
5544. **Nettel, R.** Analytische Mitteilungen aus der Erdölpraxis. *Chem.-Zeit.*, bd. xxviii, p. 867. [1904.]
5545. ——— Eine neue Viskositätsbestimmung für helle Mineralöle. *Ibid.*, bd. xxix, pp. 385, 386. [1905.]
5546. **Nettleton, E. S.** On the first systematic Collection and Discussion of the Venango County Oil Wells of Western Pennsylvania. *Proc. Amer. Phil. Soc.*, vol. xvi, pp. 429-495. [1877.]
5547. **Neuberg, C.** Zur Frage der Bildung des Erdöls. 8vo, Berlin, 1905.
5548. ——— Ueber die Entstehung optisch-aktiver Fettsäuren in der Natur. *Biochem. Zeitschr.*, bd. i, pp. 368-379. [1906.]
5549. ——— Die Entstehung des Erdöls. *Ibid.*, bd. vii, pp. 199-212. [1907.]
5550. ——— Die Entstehung des Erdöls (künstliche Darstellung von optisch-aktivem Petroleum). *Sitz. k. preuss. Ak. Wiss.*, bd. xxiv, pp. 451-455. [1907.]
5551. **Neuburger, H.** Quelques notes sur le pétrole dans le département d'Oran. *Bull. Réunion d'Etudes Algériennes*. 8vo, Paris, 1900.
5552. ——— Contribution to the Geological Investigation of the Oran Oil Basin. *1st Internat. Petrol. Congr.*, pp. 47-52, 60-67. [1900.]
5553. ——— La géologie du Pétrole et son Origine. *Rev. Sci.*, t. xvi, pp. 48-52. [1901.]
5554. ——— Torpillage et Lavage des Puits de Pétrole. *Journ. Pét.*, t. i, pp. 51-53. [1901.]
5555. ——— Le Pétrole en Algérie. Paris, 1902.
5556. ——— Le Pétrole en Espagne. *Journ. Pét.*, t. iv, pp. 123, 124. [1904.]
5557. ——— Conditions physiques et géologiques de l'existence des gisements de pétrole. *Ibid.*, t. iv, pp. 313-315, 337, 339; t. v, pp. 1, 2, 53, 55, 77, 79. [1904, 1905.]
5558. **Neuburger, H.** Les terrains de l'Etat en Roumanie. *Journ. Pétrole*, t. vi, pp. 345, 347. 1905.
5559. ——— L'Importation du Pétrole en France pendant la première Partie du XX<sup>e</sup> Siècle. *Ibid.*, t. vii, pp. 81, 83. [1907.]
5560. ——— Le pétrole en Galicie. *Ibid.*, t. viii, pp. 13, 23, 65, 67, 89, 90, 116-119, 133-135. [1908.]
5561. ——— Le beurre de pétrole. *Ibid.*, t. ix, pp. 209, 210. [1909.]
5562. ——— Alcool et Pétrole. *Ibid.*, t. x, pp. 97, 98. [1910.]
5563. ——— Le Pétrole algérien.—La région de l'Ouest.—Département d'Oran. *Ibid.*, t. xi, pp. 289, 290. [1911.]
5564. ——— La Guerre du Pétrole—ses conséquences pour l'Afrique du Nord. *La Vie Minière de l'Afrique du Nord*, 1911.
5565. **Neuburger, H., and H. Noalhat.** Technologie du Pétrole. Étude des Gisements, Recherche et Exploitation, Sondage des puits. 8vo, Paris, 1899.
5566. ——— Le Pétrole en Europe. Les nouveaux gisements de la Galicie centrale. *Rev. Techn.*, t. xxi, pp. 14-19. [1900.]
5567. **Neuendahl, L. v.** Das Vorkommen des Petroleum in Galizien und dessen Gewinnung. *Vienna*, 1865.
5568. **Neuhof-Suski, J.** Petroleum-Vorkommen in Ungarn. *Ungar. Montan-Ind. Zeit.*, bd. viii, p. 121. [1892.]
5569. ——— Petroleum-vorkommen bei Zsibo. *Ung. Montanind. Zeit.*, 1893.
5570. **Neumann, A.** Rumänien's Petroleumexport und die Donauwasserstrasse. *Petroleum Zeitschr.*, bd. ii, pp. 273-276. [1907.]
5571. ——— Die Standard Oil Company vor Gericht. *Ibid.*, pp. 961-963. [1907.]
5572. ——— Neue Ansichten der rumänischen Petroleumindustrie. *Ibid.*, p. 1028. [1907.]
5573. **Neumann, B.** Neuer Gasanalysenapparat. *Chem.-Zeit.*, bd. xxix, p. 1128. [1905.]
5574. **Neumann, M.** Ueber die staatliche Monopolisierung des Rohöls und seiner Derivate in Oesterreich-Ungarn. *Petroleum Zeitschr.*, bd. v, pp. 9-11. [1909.]
5575. ——— Zur Frage der Sanierung der Mineralöl-Industrie in Oesterreich-Ungarn. *Ibid.*, bd. vi, pp. 488-490. [1911.]
5576. **Neustadt, L.** Zur Bestimmung des Oelgehaltes in Paraffinschuppen. *Chem.-Zeit.*, bd. xxx, p. 38. [1906.]
5577. ——— Ueber die Transparenz des Paraffins. *Ibid.*, pp. 61, 62. [1906.]
- Neustadt, L., see Mittler, H.**
5578. **Newberry, J. S.** The Rock Oils of Ohio. *Ohio Agric. Report*, 1859, pp. 605-618.
5579. ——— The Oil Wells of Mecca [Ohio]. *Canad. Nat.*, vol. v, pp. 325, 326. [1860.]
5580. ——— [The Oil Wells of the Mississippi Valley.] *Sci. Amer.*, ser. 2, vol. iii, pp. 132, 133. [1861.]
5581. ——— Mineral Oil Prospectus of the Indian Creek and Jack's Knob (Cumberland and Clinton Counties, Kentucky) Coal, Salt, Oil, etc., Company. *Amer. Journ.*, ser. 2, vol. xii, p. 284. [1866.]
5582. ——— Geological Survey of Ohio. Report of Progress in 1870. 8vo, Columbus, 1871.
5583. ——— Remarkable Gas Wells in Ohio. *Amer. Chem.*, vol. i, pp. 201, 202. [1871.]
5584. ——— Notes on American Asphaltum. *Amer. Journ. Pharm.*, ser. 4, vol. ii, p. 313. [1872.]
5585. ——— Reports of the Geological Survey of Ohio. Vols. i-iii. 8vo, Columbus, 1873, 1874, 1878.
5586. ——— On the Gas Wells of Ohio and Pennsylvania. *Amer. Journ.*, ser. 3, vol. v, pp. 225-229. [1873.]
5587. ——— On the Discovery of Mineral Wax, Ozocerite, in Utah. *Ibid.*, vol. xvii, pp. 340, 341. [1879.]
5588. ——— The Origin and Relations of the Carbon Minerals. *Ann. N. York Ac. Sci.*, vol. ii, pp. 267-286. [1882.]
5589. ——— The Origin of the Carbonaceous Matter in Bituminous Shales. *Ibid.*, pp. 357-367. [1882.]

5590. **Newberry, J. S.** The Oil Field of Colorado. *Proc. Amer. Assoc.*, vol. xxvii, pp. 186, 187. [1887.]
5591. ——— The Future of Coal and Natural Gas. *Amer. Manuf.*, vol. xlv, no. 11. [1889.]
5592. ——— The new Oil-field of Colorado, and its bearing on the Question of the Genesis of Petroleum. *Trans. N. York Acad. Sci.*, vol. viii, pp. 25-28. [1889.]
5593. **Newbury, S. B., and W. P. Cutter.** The Safety of Commercial Kerosene Oils. *Amer. Chem. Journ.*, vol. x, pp. 356-362. [1888.]
5594. **Newcome, F. N.** The Mineral Wealth of Burma. *Coll. Guard.*, vol. xlv, p. 655. [1882.]
5595. **Newland, D. H.** Petroleum. *Min. Ind.*, vol. xi, pp. 497-507. [1903.]
5596. ——— The Mining- and Quarry-Industry of New York State. *Bull. N. York State Mus.*, no. 93, pp. 909-979 [1906]; no. 102, pp. 45-199 [1906]; no. 112, pp. 5-80 [1908]; no. 120, pp. 5-82 [1908]; no. 132, pp. 1-99 [1909]; no. 142, pp. 5-96 [1910]; no. 161, pp. 1-82 [1911].
5597. **Newsom, J. F. A.** A Natural-gas Explosion near Waldron (Ind.). *Journ. Geol. Chicago*, vol. x, pp. 803-814. [1902.]
- Newsome, J. F.**, see **Branner, J. C.**
5598. **Newth, G. S.** A Laboratory Method for the Preparation of Ethylene. *Journ. Chem. Soc.*, vol. lxxix, pp. 915-917. [1901.]
5599. **Newton, E. T.** On "Tasmanite" and Australian "White Coal." *Geol. Mag.*, dec. 2, vol. ii, pp. 336-342, pl. x. [1875.]
5600. **Newton, F. Hay.** Report for 1895, 1896 on the Trade of Algeria. *Dipl. Cons. Rep.*, ann. ser., no. 1899. [1897.]
5601. **Niccoli, E.** Distretto d'Ancona. *Rel. Serv. Min.*, 1880, pp. 1-34. [1883.]
5602. ——— L'Industria del Petrolio in Abruzzo. *Ibid.*, 1881, pp. 33-51. [1883.]
5603. **Nichol, B. G., and J. Gravel.** The Use and Transport of Liquid Fuel. *Trans. N. E. Coast. Inst. Eng. Shipbuild.*, vol. iii, pp. 27-51, pls. 1-11. [1887.]
5604. **Nicholas, W.** Localities of Minerals which occur in Victoria. *Rep. Geol. Surv. Victoria*, no. iii, pp. 280-288. [1875.]
5605. ——— On the reported Discovery of Coal at Sunbury. *Ibid.*, pp. 288-290. [1875.]
5606. **Nichols, —.** Oil. *San Francisco*, 1909.
5607. **Nichols, J. F.** Report on the Petroleum Oil Springs of Wyoming, U.S.A. 4to, London, 1882.
5608. **Nicholson, —.** On Bituminized Wood from an Excavation at Illawarra. *Sydney Colonist*, vol. i, pp. 61, 62. [1835.]
5609. **Nicholson, H. H.** The Mineral Resources and Operations of Cuba. *Mining Sci.*, Sept. 2, 1911.
5610. **Nicklas, J.** Cire falsifiée par de la paraffine. *Ann. Gén. Civ.*, t. iv, p. 781. [1865.]
5611. **Nickles, J. M.** Geological Section in Southern Illinois through Waterloo, Sparta, Murphysboro and Olmstead. *Rep. World's Fair Comm.*, pp. 177-223. [1895.]
5612. **Nicolardot, P., and L. Clément.** Dosage des Dérivés du Pétrole et des Produits Résineux dans les Essences de Térébenthine. *Bull. Soc. Chim. Paris*, sér. 4, t. vii, pp. 173-176. [1910.]
- Nicolas, C.**, see **Vizern, —.**
5613. **Nicoli, —.** [Petroleum of Tocco da Casauria, Abruzzo.] 1863.
5614. **Nicou, P.** Les Calcaires asphaltiques du Gard. *Ann. Mines*, sér. 10, t. x, pp. 513-568, pls. xix-xxi. [1906.]
5615. **Niedenfuhr, H. H.** Ein Erdölager der Kuban'schen Provinz im Kankasus. *Chem.-Zeit.*, bd. xx, pp. 69, 70. [1896.]
5616. **Niederstadt, B.** Untersuchung von Producten der trocknen Destillation der Braunkohlen. *Chem. Centr.*, bd. iv, pp. 154-158. [1873.]
5617. **Niedzwiedzki, J.** Beiträge zur Kenntniss der Mineralagerstätten auf dem Felde Pomierkl bei Truskawice in Galizien. *Verh. k.-k. geol. Reichs.*, 1888, pp. 239-243.
- Niemann, —**, see **Benddorf, —**
5618. **Nieszner, J.** Ueber den Ursprung der Asphaltstein-Lagerstätten Dalmatiens, mit besonderer Berücksichtigung des Vergorzener Asphaltstein-ganges. *Montan-Zeit. Oest. Ung. Balkanl.*, bd. xi, pp. 163-166. [1904.]
5619. **Nikiphorov, A.** Gewinnung von Benzol aus Erdöl und Erdölrückständen. *Chem.-Zeit.*, bd. xx, pp. 8, 9. [1896.]
5620. **Nikitin, A.** Travels to India between 1462 and 1505. *Hakluyt Soc.*, vol. xxii. 8vo, London, 1857.
5621. **Nikitin, S.** [Geological Explorations between the rivers Sok, Tcheremschan and Scheschna, Samara.] *Bull. Com. Geol. Russ.*, t. viii, pp. 165-176. [1889.]
5622. ——— [Asphaltic Sandstone of Buguruslan, Bugulma, Samara, Tetyusch, Jegulev, and Sterlitamak.] *Bull. Com. geol. Russ.*, t. xxvii, Journ., p. 254-258. [1908.]
5623. **Nikitin, S., and G. V. Khlopin.** [Pollution of Rivers with Petroleum-products, and its effect on Fish.] *Wratsch*, 1898, p. 51.
5624. **Nikitinski, Ya.** [Petroleum and its Products.] *Moscow*, 1880.
5625. **Nikoladze, N. Ya.** [Individual Opinion of a member of the Commission on the question of Oil Pipe-lines.] *Zap. Imp. Russk. Tekhn. Obsch.*, g. xix, Trudi, otd. 1, pp. 322-330. [1885.]
5626. **Nisbet, J.** Burma under British Rule—and before. 2 vols. 8vo, Westminster, 1901.
5627. **Nishio, K.** Mining Industry of Japan. *Bull. Amer. Inst. Min. Eng.*, January 1912.
5628. **Nitsch, — v.** Ueber die Entstehung der Braunkohlen, besonders der Schweißkohlen. *Festb. Verh. N. allg. deutsch. Bergmannstages Halle*, 1890.
5629. **Nitze, H. B. C.** Mineral Resources of Porto Rico. *Ann. Rep. U.S. Geol. Surv.*, vol. xx, pt. vi (non-metallic), pp. 779-787. [1899.]
5630. **Noad, J., and E. J. Townsend.** Procédé de raffinage des huiles minérales. *Journ. Pét.*, t. vii, pp. 121-123. [1907.]
- Noalhat, H.**, see **Neuburger, H.**
5631. **Nobel, L. E.** [View of the Baku Petroleum Industry, and its Future.] *Zap. Imp. Russk. Tekhn. Obsch.*, g. xi, otd. i, pp. 311-327. [1877.]
5632. ——— [On the Extended Use of Oil Residues in Furnaces, without Spraying.] Pp. 14. *Moscow*, 1882.
5633. ——— [On the Oil Industry of Russia.] *Zap. Imp. Russk. Tekhn. Obsch.*, g. xvi, otd. i, pp. 292-315, 3 pls. [1882.]
5634. ——— [The Lamp Question and the use of Oil as Fuel.] *Ibid.*, g. xvii, otd. 1, pp. 79-107, 2 pls. [1883.]
5635. **Noble, J. D.** The Canadian Petroleum Industry. *1st Internat. Petrol. Congr.*, pp. 3-5. [1900.]
5636. **Noeggerath, J. J.** Das Gebirge in Rheinland-Westphalen nach mineralogischem, und chemischem Bezuge. 4 Bde. 8vo, Bonn, 1822-1826.
5637. ——— Bergtheer und erdiges Erdpech von Lobsann bei Strasburg in Ihrer Anwendung zu gewerblichen Zwecken. *Journ. Chem. Phys.*, bd. xiii, pp. 479-483. [1824.]
5638. ——— Natürliche Naphthaline oder Scheererit von Westerwald im Herzogthum Nassau. *Ibid.*, bd. lxlii, pp. 459-464. [1831.]
5639. **Nöldeke, C.** Das Vorkommen des Petroleums im nordwestlichen Deutschland und insbesondere in der Lüneburger Heide. 8vo, Celle, 1880.
5640. ——— Die geologischen Verhältnisse von Oelheim. *Jahresb. nat. Ver. Lüneburg*, 1882, p. 53.
5641. ——— Vorkommen und Ursprung des Petroleums. 8vo, Celle, 1883.
5642. **Nöschel, A.** Geognostische Beiträge zur Kenntniss des Permischen Systems und der Jura-Ablagerungen im Orenburgischen und Busulukischen Kreise des Orenburgischen Gouvernements, und im Nikolajewischen Kreise des Saratowschen Gouvernements. *Verh. k. russ. Min. Ges.*, 1852-1853, pp. 252-332, 13 pls.

5643. **Noetling, F.** Report on the Oil-fields of Twingoung and Beme. *Rec. Geol. Surv. Ind.*, vol. xxii, pp. 75-136, pl. and map. [1889.]
5644. ——— Report on the Petroleum Industry in Upper Burma from the end of the last century up to the beginning of 1891. *Po, Rangoon*, 1892.
5645. ——— The Occurrence of Petroleum in Burma, and its Technical Exploitation. *Mem. Geol. Surv. India*, vol. xxvii, pt. 2. [1897.]
- Noiset, —**, see **Flachat, E.**
5646. **Noroo, —** Report for the year 1909 on the Trade and Commerce of Roumania. *Dipl. Cons. Rep.*, no. 4445. [1910.]
5647. **Nordenskiöld, A. E.** Utkast till Isfjordens och Belsunds geologi [Spetsbergens westkust]. *Geol. Fören. Stockh. Förh.*, bd. ii, pp. 243-260, 301-322, 356-373, pl. 13. [1875.]
5648. ——— Mineralogiska bidrag. *Ibid.*, bd. ix, pp. 26-34. [1887.]
5649. ——— Remarques sur le fer natif d'Ovifak et sur le bitume des roches cristallines de Suède. *Compt. Rend.*, t. cxvii, pp. 677, 678. [1893.]
- Nordenkiölds, A. E.**, see **Igelstrom, L. J.**
5650. **Nordenström, G.** Mineralogiska notiser. *Geol. Fören. Stockholm Förh.*, bd. iv, pp. 209, 210. [1878.]
5651. ——— Mineralogiska notiser. 4. Fynd af antracit i en jernmalmsgrufva i Norberg. *Ibid.*, pp. 340, 341. [1879.]
5652. ——— Om Varmskogs og angränsande söcknar silfver- och kopparmalmgångar i Vestra Vermland. *Ibid.*, bd. v, pp. 455-469, pl. xviii. [1881.]
5653. ——— [Combustible gas in zinc mine at Ammeberg, Nerike.] *Ibid.*, bd. xviii, pp. 177, 178. [1896.]
5654. ——— Förekomst af brännbar gas i malmgrufvor. *Ibid.*, pp. 637-640. [1896.]
5655. **Nordström, T.** Om i Falutrakten förekommande mineralbrott. *Geol. Fören. Stockh. Förh.*, bd. i, pp. 119-123, pl. ix. [1872.]
5656. ——— Sumpgasutveckling och fynd af bernsten vid en djupborrning i Skåne. *Ibid.*, bd. ii, pp. 161, 162. [1874.]
5657. ——— Om Torpa saltkälla. *Ibid.*, pp. 236-241, pl. 11. [1875.]
5658. **Normann, W.** Versuche zur Molekulargewichtsbestimmung von Oelen und Fetten. *Chem.-Zeit.*, bd. xxxi, pp. 211-214. [1907.]
5659. **North, E.** The Pico Canon Oil-field. *10th Ann. Rep. State Mineral. California* for 1890, pp. 283-299.
5660. **North, E. P.** The Construction and Maintenance of Roads. *Trans. Amer. Soc. Civ. Eng.*, vol. viii, pp. 95-147, 333-380, pls. xxv-xxviii. [1919.]
5661. **North, S. H.** Petroleum; its Power and Uses. 8vo. London, 1904.
5662. ——— Oil Fuel: its Supply, Composition, and Application. 8vo. London, 1905.
5663. ——— Under the Malkop Oil Field. *Petrol. World*, vol. viii, p. 44. [1911.]
5664. **Norton, J. T.** The Resources of Fremont County [Wyoming]. 1891.
5665. **Norton, L. M.**, and **C. W. Andrews.** The Action of Heat on Liquid Paraffins. *Amer. Chem. Journ.*, vol. viii, pp. 1-9. [1886.]
5666. **Noth, J. A.** Die Erdölgruben in Bóbrka bei Dukla in Mittelgalizien. *Jahrb. k.-k. geol. Reichs.*, bd. xviii, pp. 311-314. [1868.]
5667. ——— Die Kohlen-Wasserstoffgas-Ausströmungen in und um Bad Iwonicz in Mittelgalizien. *Verh. k.-k. geol. Reichs.*, 1868, pp. 193-196.
5668. ——— Ueber eine beim Abbohren eines Naphtabrunnens in Bóbrka aufgeschlossene Mineralquelle. *Ibid.*, 1869, pp. 139-141.
5669. ——— Nachrichten über die Resultate von Bohrungen auf Erdöl bei Kleczany und Ropianska in Westgalizien. *Ibid.*, 1870, pp. 335, 336.
5670. ——— Ueber die Bedeutung von Tiefbohrungen in der Bergölzone Galiziens. *Jahrb. k.-k. geol. Reichs.*, bd. xxiii, pp. 1-18. [1873.]
5671. **Noth, J. A.** Kleinere Mittheilungen . . . (?) Kalkstein von Swiatkowa in der Herrschaft Miskowa bei Zmigrod in Galizien, mit Drusen, welche Bergöl und Verdunstungsrückstände enthalten. . . . *Verh. k.-k. geol. Reichs.*, 1874, pp. 244-246.
5672. ——— Die Erdöl- und Erdwachsgegewinnung in Boryslaw. *Oesterr. Zeitschr. Berg-Hüt.*, bd. xxlii, pp. 131-133. [1875.]
5673. ——— Beitrag zur Petroleumgewinnung und Betrachtung über die tiefste Petroleumbohrung in Galizien. *Ibid.*, bd. xxiv, pp. 28, 29, 38, 39, 48, 49, 58-60. [1876.]
5674. ——— Geologische Mittheilungen über die Umgehung von Synowudzko Korczyn im Stryeser Bezirke Galiziens, mit besonderer Berücksichtigung der auf Petroleumvorkommen und Gewinnung bezüglichen Verhältnisse. *Zeitschr. Paraff. Indust.*, 1879, pp. 63-67.
5675. ——— Petroleumvorkommen in Ungarn. *Verh. k.-k. geol. Reichs.*, 1885, pp. 83-85.
5676. ——— Ueber die bisher erzielten Resultate und die Ansichten von Petroleumschürfungen in Ungarn. Vortrag gehalten am mont. hüttenm. geol. Congress zu Budapest, 1885. *Allg. österr. Chem.-Techn.-Zeit.*, bd. iii, pp. 584-595. [1885.]
5677. ——— Bergtheer- und Petroleumvorkommen in Kroatien-Slavonien und in südwestlichen Ungarn. *Földt. Köz.*, köt. xvii, pp. 348-362. [1887.]
5678. ——— Petroleumposition Wietrzno bei Dukla in Galizien. *Allg. österr. Chem.-Techn.-Zeit.*, bd. vi. [1888.]
5679. ——— Bohrungen auf Petroleum in Ungarn; ein neues Arbeitsfeld für Bohrunternehmungen. *Ibid.*, bd. vii, nos. 12, 14. [1889.]
5680. ——— Petroleumvorkommen in Ungarn. *Ibid.*, bd. x, no. 13. [1892.]
5681. ——— Petroleum in Ungarn. *Ibid.* (no. 18), p. 1362. [1892.]
5682. ——— Petroleumvorkommen in Körösmezö. *Ibid.*, nos. 20, 21; bd. xi, p. 71. [1892, 1893.]
5683. ——— Bohrungen in den Mulden der galizischen Petroleumzonen und in Ungarn. *Montan-Zeit. Oesterr.-Ungarn Balkanl.*, 1894, p. 293.
5684. ——— Petroleumconclusionen in dem Gebiete zwischen Jaslo und Bartfeld. *Allg. österr. Chem.-Techn.-Zeit.*, bd. xvi, no. 1. [1895.]
5685. ——— Ueber die Petroleumvorkommen von Komarnik, Mikowa und Lub. *Földt. Köz.*, köt. xxvii, pp. 99-104. [1903.]
5686. ——— Das Petroleumvorkommen in der Umgehung von Sanok in Galizien. *Allg. österr. Chem.-Techn.-Zeit.*, bd. xxvi, pp. 9, 10, 17, 15, 26, 27, 37, 38, 49-51, 67-69, 83-85, 89-91, 97-100, 113-115, 121-123, 129-131, 146, 147, 170-172, 179-181, 187-189; map. [1908.]
5687. ——— Das Erdöl- und Erdwachs-vorkommen von Boryslaw-Tustanowice in Galizien, und die Ursachen der Verwitterung eines Theiles dieser Oelfundorte. *Mitth. geol. Ges. Wien*, bd. iv. [1911.]
5688. ——— Das Erdöl-vorkommen in Galizien im Lichte neuer Erfahrungen. *Org. Ver. Bohrtechn.*, bd. xviii, pp. 25-27. [1911.]
5689. ——— Bemerkungen zu dem Gesetze des ungarischen Finanzministers von Lncaks über die Monopolisierung der flüssigen und gasförmigen Bitumina und über die nachtheiligen Folgen der Entziehung der Bitumina vom Bergregale in Galizien. *Ibid.*, pp. 37-40, 51-54. [1911.]
5690. ——— Arbeitsfeld für Bohrunternehmungen in Ungarn nach Einführung des neuen Petroleumberggesetzes. *Ibid.*, pp. 257-261. [1911.]
5691. **Novakowski, M.** [Geology and Mineral Wealth of the Uralsk Province.] *Gorn. Journ.*, 1887, t. 4, pp. 82-122, map.
5692. **Novarese, V.** I giacimenti di asfalto di San Valentino (Chieti). *Rass. Min.*, t. xx. [1904.]
5693. **Novellas, —**. [Ozokerite and Asphalt Shales in Gerona.] *Bull. Inst. Catal. Hist. Nat.*, t. i. p. 10. [1901.]
5694. **Novi, G.** Gli Idrocaburi liquidi e solidi; Utilità di coltivare le miniere in quelle Province d'Italia dove e' piu attiva l'Emigrazione. 4to, Naples, 1884,

5695. **Novoa, B.** Neue Apparate für quantitative Lotheruntersuchungen. *Berg-Hütt. Zeit.*, bd. lvi, pp. 423, 424. [1897.]
5696. **Noyes, W. A., W. M. Blinks, and A. V. H. Mory.** Oil-Gas. *Journ. Amer. Chem. Soc.*, vol. xvi, pp. 688-698. [1894.]
5697. **Nugent, —.** Reports for the years 1905-8 on the Trade, etc., of Texas. *Dipl. Cons. Rep.*, ann. ser., nos. 3585, 3857, 4039, 4263. [1906-1909.]
5698. **Nugent, N.** Account of the Pitch Lake of the Island of Trinidad. *Trans. Geol. Soc.*, vol. i, pp. 63-76. [1811.]
5699. **Nunn, L. J.** Reports for the years 1908-1910 on the Trade and Commerce of the Consular District of Vera Cruz. *Dipl. Cons. Rep.*, ann. ser., nos. 4258, 4464, 4665. [1909-1911.]
5700. **Nuricsan, J.** [Mezohegyes Gas-spring.] *Magyar. chem. Polyoirat*, köt. viii, 1902.
5701. **Nystomer, C., J. J. Kyle, A. Quiroga, and J. A. Buschiazzo.** Informe sobre Pavimentos de Asfalto. *An. Soc. Ci. Argent.*, t. xxviii, pp. 231-239. [1889.]
5702. [G.] Petroleum in den Jahren 1869 und 1870. *Berggeist*, bd. xvi, p. 147. [1871.]
5703. **Obalski, J.** Report on the Mining Service, 1885. *Rep. Comm. Crown Lands, Quebec*, 1885.
5704. **Obruchev, V.** [Geological Researches in Bokhara and Zaravshan, 1887.] *Mat. Geol. Russ.*, t. xiii, pp. 65-184. [1889.]
5705. **Ochsenius, C.** [Mother-liquors.] *Zeitschr. deutsch. geol. Ges.*, bd. xxxiii, pp. 507-511. [1881.]
5706. ——— Petroleum-Bildung. *Natur*, 1882, no. 29.
5707. ——— Zur Entstehung des Erdöls. *Chem.-Zeit.*, bd. xv, pp. 935-940, 1735-1737. [1891.]
5708. ——— Erdöl und Asphalt bei Palena in der peruanischen Provinz Payta. Beziehung zwischen Salz und Kohle. *Ibid.*, pp. 1866, 1867. [1891.]
5709. ——— Zur Entstehung des Erdöles. *Ibid.*, bd. xvi, p. 1923; bd. xx, pp. 383, 384. [1892, 1896.]
5710. ——— Bedeutung des orographischen Elementes "Barre" in Hinsicht auf Bildungen und Veränderungen von Lagerstätten und Gesteinen. *Zeitschr. prakt. Geol.*, bd. i, pp. 189-201. [1893.]
5711. ——— Kohle und Petroleum. *Ibid.*, bd. iv, pp. 65-68. [1896.]
5712. ——— Die Bildung des Erdöls. *Ibid.*, pp. 219-221. [1896.]
5713. ——— Erdölbildung. *Zeitschr. deutsch. geol. Ges.*, bd. xlvi, pp. 239, 685, 686. [1896.]
5714. ——— Erdöl und Salz. *Chem.-Zeit.*, bd. xxi, p. 57. [1897.]
5715. ——— Petroleum und Salz in Rumänien. *Zeitschr. prakt. Geol.*, bd. vi, pp. 25, 26, 316-318. [1897.]
5716. ——— Methan, Bitumen, Asphalt, Anthracit, Graphit, Diamant. *Ibid.*, pp. 153-158. [1898.]
5717. ——— Erdöl- und Erzstudien. *Allg. österr. Chem.-Techn.-Zeit.*, bd. xxi, nos. 17-20. [1903.]
5718. ——— Zur Entstehung des Erdöls. *Zeitschr. prakt. Geol.*, bd. xiv, pp. 54-56. [1906.]
5719. ——— Erdölvorkommen in der Provinz Posen. *Petroleum Zeitschr.*, bd. i, pp. 722-724. [1906.]
5720. **O'Connor, —.** Petrol Air Gas. *Svo, London*, 1909.
5721. **Odeleben, — v.** Ueber das Erdöl von Miano bei Parma. *Ann. Phys.*, bd. lx, pp. 219-223. [1819.]
5722. **Odintsov, A.** [Is it practicable to compel the Replacement of Wood by Iron for Petroleum Tankships?] *Zap. Imp. Russk. Tekhn. Obsch.*, g. xxxiii, Trudi, pp. 373-437. [1899.]
5723. **Odling, W.** On the Constitution of the Hydrocarbons. *Proc. Roy. Inst.*, vol. ii, pp. 63-66. [1854.]
5724. ——— The Paraffins and their Alcohols. *Ibid.*, vol. viii, pp. 86-100. [1876.]
5725. ——— On the Formulation of the Paraffins and their Derivatives. *Phil. Mag.*, ser. 5, vol. i, pp. 216-217. [1876.]
5726. **O'Donovan, E.** The Merv Oasis. 2 vols. *Svo, London*, 1882.
5727. **Oebbecke, K.** Die Bedeutung Galziens und Rumäniens für die Erdöl Production im allgemeinen, und die Versorgung Deutschlands im besonderer. *Allgemeine Zeitung*, no. 27, Jan. 28, 1900.
5728. ——— Das Erdöl und die Bedeutung Regensburgs für den deutschen Petroleummarkt. *Ber. Nat. Ver. Regensburg*, 1900, h. 8
5729. ——— Ueber die Verbreitung und die Produktion des Erdöls unter besonderer Berücksichtigung der für Deutschland wichtigsten Produktionsgebiete. *Bayer. Ind. Gewerbd.*, bd. xxxii, pp. 145-147, 153-157. [1900.]
5730. ——— Ueberblick über den heutigen Stand des Dieselmotorbaues und die Versorgung mit flüssigen Brennstoffen. *Zeitschr. Ver. deutsch. Ing.*, bd. lv, pp. 1345-1353. [1911.]
5731. ——— Das Vorkommen, die Beschaffenheit und die wirtschaftliche Bedeutung des Erdöls. *Petroleum Zeitschr.*, bd. vi, pp. 2169-2175. [1911.]
5732. **Oebbecke, K., and M. Blanckenhorn.** Bericht über die im Herbst 1899 gemeinsam unternommene geologische Rekognoszierungsreise in Siebenbürgen. *Verh. siebenbürg. Ver. Nat.*, bd. i, pp. 1-42. [1901.]
- Oechelhäuser, H.**, see **Haber, F.**
5733. **Oehler, E.** Beiträge zur Chemie des Braunkohlentheers. *Zeitschr. angew. Chem.*, bd. xiii, pp. 561-563. [1899.]
5734. **Oelsner, J. W.** Ueber das Paraffin. *Uebers. Schles. Ges.*, 1857, p. 175; 1838, p. 179.
5735. **Oeynhausens, K. v.** Bemerkungen über die Aufertigung und den Effect der aus Hohlleisen zusammengesetzten Bohrstänge. *Arch. Min. Geogn.*, bd. xxi, pp. 135-160. [1847.]
- Oeynhausens, K. v.**, see **Dechen, H. v.**
5736. **Offer, T.** Analyse der Fette und Oele. *Hanover*, 1907.
5737. **Offermann, —.** Viskositätsbestimmung kleiner Oelmengen im Engler'schen Viskosimeter. *Chem. Rev. Fett-Harz-Ind.*, bd. xviii, pp. 272-275. [1911.]
5738. ——— Zur Schmelzpunktbestimmung von künstlichem Asphalt aus Rohpetroleum. *Petroleum Zeitschr.*, bd. vi, p. 217. [1911.]
5739. **Ogloblin, V. N.** [Experiments on Kerosene, offered for sale at Kiev.] *Jurn. Russk. Fiz. Khim. Obsch.*, t. xii, otd. i, pp. 138-147. [1880.]
5740. ——— [Aniline-Toluene Oil from Caucasian Naphtha.] *Ibid.*, t. xxxvi, pp. 680-711. [1904.]
5741. ——— [Benzene and its Homologues from Russian Petroleum by Nikiforov's Process.] *Russk. Farb.-Textilind.*, bd. iii, pp. 293, 294. [1904.]
- Ogloblin, V. N.**, see **Markovnikov, V.**, and **Ragozin, V. I.**
5742. **O'Gorman, M.** Carburettors. *Proc. Inst. Automob. Eng.*, vol. vii. [1905.]
5743. **Ohly, J.** Ozokerite. *Min. Sci. Press*, vol. lxxxii, pp. 8, 9. [1900.]
5744. ——— The Origin of Petroleum. *Mines and Minerals*, vol. xxii, pp. 532, 533. [1902.]
5745. **Okulus, A.** Ueber einige Petroleumfundorte in Ungarn. *Oesterr. Zeitschr. Berg-Hütt.*, bd. xxxi, pp. 485-488. [1883.]
5746. ——— Ueber Chancen des Petroleumbaues in Ungarn. *Oesterr.-Ungar. Montan-Ind.-Zeit.*, bd. iii, p. 99. [1887.]
5747. ——— Ozokeritvorkommen in der Marmaros. *Allg. österr. Chem.-Techn.-Zeit.*, bd. xvi, no. 21. [1898.]
5748. **Okulus, H.** Beitrag zu einer rationellen Petroleumschürfung. *Oesterr. Zeitschr. Berg-Hütt.*, bd. xxx, pp. 6-8. [1882.]
5749. **Oldham, R. D.** Special Report on the most favourable sites for Petroleum Exploration in the Harnai District, Baluchistan. *Rec. Geol. Surv. Ind.*, vol. xxiii, pp. 61-59, map. [1890.]
5750. ——— Report on the Geology and Economic Resources of the Country adjoining the Sind Fishin Railway between Sharigh and Spintangi and of the country between it and Khattan. *Ibid.*, pp. 104-109. [1890.]



5751. **Oldham, R. D.** Preliminary Report on the Oil Locality near Moghal Kot in the Sherani country, Suleiman Hills. *Rec. Geol. Surv. Ind.*, vol. xxiv, pp. 83, 84. [1891.]
5752. ——— Report on the Geology of Thal Chotial and part of the Mari Country. *Ibid.*, vol. xxv, pp. 18-29, map and 5 pls. [1892.]
5753. ——— Manual of the Geology of India. 8vo, *Calcutta*, 1893.
5754. ——— The Petroleum Fields of India. *Journ. Soc. Arts*, vol. xlii, pp. 145-156. [1894.]
5755. ——— Les Bruits de Tremblements de Terre et les "Barisal Guns." *Bull. Soc. belge Géol.*, t. xv, Proc. verb., pp. 57, 58. [1901.]
5756. **Oldham, T.** Memorandum on the results of a cursory examination of the Salt Range and parts of the districts of Bunnoo and Kohat, with special views to the mineral resources of those districts. *Select Records Cont. India*, vol. lxiv, pp. 126-156. [1867.]
5757. ——— Discovery of Petroleum near Thayetmyo. *Ind. Econ.*, vol. iii, pp. 191-193. [1872.]
- Oldham, T.**, see **Yule, H.**
5758. **Olearius, A.** [Voyages and Travels of the Ambassadors sent by Frederick, Duke of Holstein, to the Great Duke of Muscovy and the King of Persia, 1647, 1656, 1669.] *Fo. London*, 1662.
5759. **Olie, G.** [Hydraulic Drilling in the Orenoi Oilfield.] *Monit. Ind. Pétrol Roum.*, t. vi, pp. 958-960. [1906.]
5760. **Oliphant, F. H.** Petroleum. Natural Gas. *Ann. Rep. U.S. Geol. Surv.*, vols. xviii-xxi; *Min. Res. U.S.*, 1900-1904. [1897-1906.]
- Oliphant, F. H.**, see **Day, D. T.**
5761. **Oliveri, V.** Sui dilixene e suoi prodotti ossidazione. *Gazz. Chim. Ital.*, t. xii, pp. 158-161. [1882.]
5762. ——— Studio sul paraxilenol. *Ibid.*, pp. 161-167. [1882.]
5763. **Ollivier, C. P.** Sur un nouveau gisement du Bitume élastique [Montrelais]. *Ann. Sci. Nat. Zool.*, t. ii, pp. 149-154. [1824.]
5764. **Olzowski, P.** [On the behaviour of Ethane and Propane at Low Temperature and under Pressure.] *Rozpr. Ak. Umiej. Krakow*, t. xix, p. xvi. [1889.]
5765. **Olzowski, S.** [Origin and Appearance of Petroleum in Galicia.] *Kosmos*, t. vi, pp. 522-530. [1881.]
5766. ——— Studien über die Verhältnisse der Petroleum Industrie in Rumanien. *Oesterr. Zeitschr. Berg-Hütt.*, bd. xxxi, pp. 424-426, 431-433, 445-447, 459, 460, 467-469, 479, 480, 499-502, 526-529. [1883.]
5767. ——— [Statistics of Galician Oil Wells for March 1896.] *4to, Lemberg*, 1896.
5768. ——— Ueber die Aussichten der Petroleumschürfungen im Thale des Laboreclusses bei Radvan (in Oberungarn). *Zeitschr. prakt. Geol.*, bd. ix, pp. 353-356. [1901.]
5769. ——— Die Petroleum-Industrie in Galizien (Oesterreich) in den Jahren 1884 bis 1901. *Naphta*, bd. x, pp. 333-337. [1902.]
5770. ——— Über die rohölführenden miocänen resp. oberoligocänen Schichten des Tales Putilla in der Bukowina. *Zeitschr. prakt. Geol.*, bd. xii, pp. 321-324. [1904.]
5771. ——— Petroleumfund in Zboro (Ungarn). *Naphta*, bd. xiv, p. 370. [1906.]
5772. ——— Ueber die Berggesetz-Reform. *Ibid.*, bd. xvi, pp. 123-128, 149-151. [1908.]
5773. **Omelianski, V.** Ueber Methanbildung in der Natur bei biologischen Prozessen. *Centr. Bakt. Parasitenz.*, abth. 2, bd. xv, pp. 673-687. [1906.]
5774. **Ommegauck, M. C.** Extinction du pétrole à l'aide du chloroforme. *Bruzelles*, 1874.
5775. **O'Neill, C.** Paraffin Oil. A report on the quality of illuminating oils sold in Manchester and the Neighbourhood. 1862.
5776. **O'Neill, E.** Petroleum in California. *Compt. Rend. Congr. internat. Chem. appl.*, sess. 5, t. ii, pp. 760-775. [1904.]
- O'Neill, E.**, see **Lengfeld, F.**
5777. **Oppermann, —.** Map showing portions of Warren and Forest Counties, embracing the Kinzua, Stoneham, Clarendon, Tioga and Blue Jay developments. *Bradford, Penns.*
5778. **Oppermann, A.** Note sur des Dégagements de Gaz inflammables survenus dans les Carrières d'Argile réfractaire de Bollène. *Ann. Mines*, sér. 9, t. viii, Mém., pp. 6-19. [1895.]
5779. **Oppermann, C. A.** Réservoirs à pétrole des Docks de Saint-Ouen, près Paris, par MM. Séraphin frères, ingénieurs-constructeurs. *Nouv. Ann. Construct.*, sér. 3, t. ii, p. 83, p. 27. [1877.]
5780. **Oppler, Th.** Handbuch der Fabrikation der Minerale aus Steinkohlen, Braunkohlen, Holz, Torf, Petroleum und anderen bituminösen Substanzen, so wie der Gewinnung von künstlichen Farbstoffen des Anilins und verwandter Produkte des Steinkohlentheers. 8vo, *Berlin*, 1862.
5781. **Orde, E. L.** Liquid Fuel Burner. *Automotor Journ.*, vol. iv, p. 386. [1900.]
5782. ——— Liquid Fuel. *Trans. N.E. Coast Inst. Eng. Shipbuild.*, vol. xvii, pp. 41-55, 69-71, 85-88. [1901.]
5783. ——— Liquid Fuel for Steamships. *Proc. Inst. Mech. Eng.*, 1902, pp. 417-435, pls. 42-46.
5784. **Ordinaire, C. N.** Histoire Naturelle des Volcans, comprenant les Volcans Soumarins, ceux de Boue, et autres Phénomènes Analogues. 8vo, *Paris*, 1802.
5785. **Ordenez, E.** Sobre algunos Ejemplos probables de Tubos de Erupcion. *Mem. Soc. cient. Aizate*, t. xxii, pp. 141-154. [1904.]
5786. ——— Oil in the State of Vera Cruz. *Min. Sci. Press*, vol. xcv, pp. 247, 248. [1907.]
5787. ——— Occurrence and Prospects of Oil in Mexico. *Eng. Min. Journ.*, vol. lxxxix, p. 1020. [1910.]
5788. **Ordway, J. M.** and **E. Atkinson.** [Report on Testing Lubricants.] *Proc. New Engl. Cotton Manuf. Assoc.*, Oct. 1878.
5789. **Orgels, L.** Une exploration en Italie. Le Commerce, L'Agriculture. L'Industrie. Le Pétrole en Italie. Questions ouvrières. 16mo, *Ghent*, 1890.
5790. **Orgels, L.** — Todros, and — Jassin. Rapport sur les Gisements Pétroliers de San Giovanni Incarico. 16mo, *Brussels*, 1890.
5791. **Orioli, F.** Gas idrogeno protocarburato nelle acque della Porretta. *Giorn. Farm. Chim. Sci. Access.*, t. x, pp. 146-149. [1829.]
5792. **Orlando, S.** Prove di combustione a petrolio sul piroscalo Tebe. *Riv. Maritt.*, ann. xxxvii, pp. 629-635; 3 pls. [1904.]
5793. **Orlov, E. T.** [Synthesis of Ethylene from Carbon Monoxide and Hydrogen by Contact with Nickel and Palladium.] *Journ. Russ. Fiz. Khim. Obsch.*, t. xi, pp. 1588-1590. [1908.]
5794. **Orr, H.** Petroleum Fuel. *Journ. Franklin Inst.*, vol. lxxxiv, p. 27. [1872.]
5795. **Orsi, G.** I bitumi ed il petrolio di Tocco nel Abruzzo. *Ancona*, 1866.
5796. **Orth, —.** Ueber die Leuchtkraft von Schieferölen. *Geuerb. Bl. Würt.*, 1857, p. 208.
5797. **Ortolan, J. A.** Mémoire sur les huiles minérales employées à lubrifier les mouvements des machines et sur la conservation des chaudières à vapeur. *Bull. Soc. Acad. Brest*, sér. 2, t. vii. [1881.]
5798. **Orton, E.** The Berea Grit of Ohio. *Proc. Amer. Assoc.*, vol. xxx, pp. 167-174. [1881.]
5799. ——— A Source of the Bituminous Matter in the Devonian and Sub-Carboniferous Black Shales of Ohio. *Ibid.*, vol. xxxi, pp. 373-384. [1883.]
5800. ——— The Horizons of Petroleum and Inflammable Gas in Ohio. *Ibid.*, vol. xxxiii, pp. 397, 398. [1885.]
5801. ——— The recently discovered sources of Natural Gas and Petroleum in North-western Ohio. *Ibid.*, vol. xxxiv, pp. 202-204. [1886.]
5802. ——— The Record of the Deep Well of the Cleveland Rolling Mill Company, Cleveland, Ohio. *Ibid.*, pp. 220-222. [1886.]

5803. **Orton, E.** Preliminary Report upon Petroleum and Inflammable Gas [Ohio]. 8vo, Columbus, 1836.
5804. ——— Petroleum and Natural Gas as found in Ohio. *Science*, vol. vii, pp. 560-564, map. [1886.]
5805. ——— Geological Survey of Ohio, vol. vi. Economic Geology. 8vo, Columbus, 1888.
5806. ——— The Trenton Limestone as a Source of Petroleum and Inflammable Gas in Ohio and Indiana. *Ann. Rep. U.S. Geol. Survey*, vol. viii, pp. 475-662, pls. liv-lx. [1889.]
5807. ——— The New Horizons of Oil and Gas in the Mississippi Valley. *Proc. Amer. Assoc.*, vol. xxxvii, pp. 181, 182. [1889.]
5808. ——— Origin of the Rock Pressure of Natural Gas in the Trenton Limestone of Ohio and Indiana. *Bull. Geol. Soc. Amer.*, vol. i, pp. 87-97. [1890.]
5809. ——— Report on the Occurrence of Petroleum, Natural Gas and Asphalt Rock in Western Kentucky, based on examinations made in 1888 and 1889. 8vo, Frankfort, Ky., 1891.
5810. ——— On the Origin and Accumulation of Petroleum and Natural Gas in the Trenton and Clinton Limestones. 1st *Ann. Rep. Geol. Surv. Ohio*. [1892.]
5811. ——— From the Ohio River to Chicago. Itinerary. *Compt. Rend. V. Congr. Géol. Internat.*, pp. 291-298. [1893.]
5812. ——— Geological Probabilities as to Petroleum. *Bull. Geol. Soc. Amer.*, vol. ix, pp. 85-100. [1898.]
5813. ——— Geological Structure of the Iola Gas Field. *Ibid.*, vol. x, pp. 99-106, pl. ii. [1899.]
5814. ——— Petroleum and Natural Gas in New York. *Bull. N. Y. State Mus.*, vol. vi (*Ann. Rep. N. Y. State Mus.*, vol. iii), pt. i, appendix i, pp. 395-526, 3 maps. [1899.]
- Orton, E.**, see **Lesley, J. P.**
5815. **Osborne, W.** Echoes from the Oil Country. Shooting a Well. *American Machinist*, vol. xxiii, pp. 846, 847. [1900.]
- Osceanu, C.**, see **Mrazec, L.**
5816. **Osipov, I. P.** [Heats of Combustion of Stilbene and the isomeric Nononaphthenes.] *Jurn. Russk. Fiz. Khim. Obsch.*, t. xx, pp. 643-650. [1888.]
5817. **Osmaston, J.** Old All; or, Travels Long Ago. An Account of a Journey to Persia in 1861. London, 1881.
5818. **Oskov, P.** [Geological Notes (Structure of the Caspian Region).] *Samara Kalendar* for 1889, pp. 30-63. [1888.]
5819. **Ossendovski, A. M.** [Coals and Carbonaceous Minerals of far-eastern Russia from a Chemical Standpoint.] *Gorn. Journ.*, 1905, t. 3, pp. 85-133, 200-263.
5820. **Ostertag, P.** Der umsteuerbare Sulzer-Diesel-Schiffsmotor. *Schweiz. Bauzeit.*, bd. xlix, pp. 167, 168 [1907.]
5821. **Ostrejko, R. A.** [Influence of Sunlight and Air on Petroleum Products. Capacity of Petroleum for absorbing Atmospheric Constituents.] *Trudi Bak. Otd. Imp. Russk. Techn. Obsch.*, 5od. x, pt. 2, p. 21; pt. 4, p. 19; pt. 6, p. 1. [1896.]
5822. ——— Die Regeneration der Schwefelsäure aus der Abfallsäure der Mineralölfabriken. *Naphtha*, bd. x, pp. 258-260. [1902.]
5823. ——— Neue Destillationsmethode des Theers und der schweren Rohöle, die sich vom Wasser durch Abstehen nicht trennen lassen. *Ibid.*, pp. 293-295. [1902.]
5824. **Ostrogovich, A.** [Elementary Analysis of Crude Petroleum.] *Bull. Soc. Sci. Bucur.*, t. xiv, pp. 314-316. [1905.]
5825. **Ostromislenski, J.**, and **J. Buryanads.** [Pyrogenetic Decomposition of Petroleum by the Catalysts.] *Jurn. Russ. Fiz. Khim. Obsch.*, t. xlii, p. 195. [1910.]
5826. **Ott, A.** Das Petroleum als Schmiermaterial für Maschinen. *Polyt. Journ.*, bd. clxxxiii, pp. 246, 247. [1867.]
5827. **Ott, A.** Lugo's Destillirapparat für Petroleum. *Polyt. Journ.*, bd. clxxxv, pp. 194-196. [1867.]
5828. ——— Ueber das amerikanische Vulkanöl. *Ibid.*, bd. clxxxvii, pp. 171-173. [1868.]
5829. ——— Notizen über Erdöl. *Ibid.*, bd. clxxxviii, pp. 255, 256. [1868.]
5830. ——— The Effect of Light on Mineral Oils. *Amer. Journ. Min.*, vol. vii, p. 202. [1869.]
5831. ——— Van der Weyde's praktische Beiträge zur Kenntniss des Petroleums und dessen Destillaten. *Deutsch. Illustr. Gewerbezeit.*, bd. xxxv, pp. 2, 3. [1870.]
5832. ——— Das Petroleum, seine Entdeckung, Ausbeutung und Verwerthung in den Vereinigten Staaten, nebst Mittheilungen über die Prüfung auf seine Feuegfähigkeit. *Müth. nat. Ges. Bern*, 1874, pp. 16-42. [1875.]
5833. ——— Ueber die Refinement des Rohpetroleum. *Chem. Centr.*, f. 3, bd. vii, pp. 704, 719, 720. [1876.]
5834. ——— Collectaneen für das Asphaltverfahren. *Phot. Corresp.*, bd. xvi, pp. 98-100. [1879.]
5835. **Otten, G.** Ueber ein Erdöl aus Argentinien. 8vo, Karlsruhe, 1888.
- Otten, G.**, see **Engler, C.**
5836. **Ottilia, —.** Das Vorkommen, die Aufsuchung und Gewinnung der Braunkohlen in der Preussischen Provinz Sachsen. *Zeitschr. Berg-, Hüt.-Salin. Preuss.*, bd. vii, pp. 201-253, pls. xv, xvi; bd. viii, pp. 1-27, 113-152, 315-332, pls. i, ii, iv-ix. [1859, 1860.]
5837. **Otto, C. F.** Maschinen-Öle. *Seifenst.-Zeit.*, bd. xxxviii, pp. 539, 540, 582. [1911.]
5838. ——— Motoren-Zylinderöle. *Ibid.*, pp. 629, 630, 657, 680, 681. [1911.]
5839. **Otto, M.** Recherches sur l'Ozone. *Ann. Chim. Phys.*, sér. 7, t. xiii, pp. 77-144. [1898.]
5840. **Otto, R.**, and **E. Dreher.** Notiz über das Verhalten des Dibenzyls in höherer Temperatur. *Ann. Chem. Pharm.*, bd. cliv, pp. 176-178. [1870.]
5841. **Ottow, M. W.**, and **P. A. A. F. Eijken.** Bijdrag nit het Scheikundig Laboratorium. . . . *Jahr. Mijnev. Ned. O.-Ind.*, jg. xxiii, Wet., pp. 167-213. [1894.]
5842. **Ouseley, W.** Travels in various Countries of the East, more particularly Persia, in 1810-12. 3 vols. 4to, London, 1819.
- Oussor, P.**, see **Usov, P.**
5843. **Outerbridge, A. E.** A Practical Application of Fluorescence in Testing Oils for Industrial Purposes. *Journ. Franklin Inst.*, vol. clxxxii, pp. 591-599. [1911.]
5844. **Oven, A. V.** [Firing with Petroleum Residues.] *Zap. Odessk. Otd. Imp. Russk. Tekhn. Obsch.*, 1887, Jan.-Feb., pp. 27-30.
5845. **Owen, D. D.** Reports of the Geological Survey of Kentucky. 4 vols. 8vo, Frankfort, Ky., 1856-1861.
5846. ——— Second Report of a Geological Reconnaissance of the middle and southern Counties of Arkansas made during the years 1859 and 1860. 8vo, Philadelphia, 1860.
5847. **Owen, R.** On Petroleum and Oil-wells. *Fraser's Mag.*, Oct. 1875.
5848. **P——, S.** Oelspringbrunnen in Ssurachany. *Naphtha*, bd. xv, p. 473. [1907.]
5849. **Pagani, —.** Sorgenti di petrolio nel Bolognese. *Ris. Min.*, t. xvii, 1900.
5850. **Page, L. W.** Report of Committee II on Standard Tests for Road Materials. *Proc. Amer. Soc. Test. Mat.*, vol. v, pp. 102, 104; vol. vi, pp. 82-84. [1905, 1906.]
5851. ——— Report of Committee D-4 on Standard Tests for Road Materials. *Ibid.*, vol. x, pp. 149-154. [1910.]
5852. ——— Progress Reports of Experiments in Dust Prevention and Road Preservation. *U.S. Office of Public Roads*, Circs. 92, 94. [1910, 1911.]
5853. ——— Oil-mixed Portland Cement, Mortar, and Concrete. *Trans. Amer. Soc. Civ. Eng.*, vol. lxxiv, pp. 255-287. [1911.]

5854. **Pagliani, S.** Sopra alcune proprietà fisiche dei petroli con una osservazione intorno al metodo della boccetta per la determinazione del peso specifico dei corpi solidi e liquidi. *Gazz. Chim. Ital.*, vol. xiii, p. 495. [1883.]
5855. — Sui petroli italiani. *Giorn. Scient. Palermo*, t. i, no. 3. [1895.]
5856. **Paige, S.** Mineral Resources of the Llano-Burnet Region, Texas, with an Account of the Precambrian Geology. *Bull. U.S. Geol. Surv.*, no. 450. Pp. 103, 5 pls. [1911.]
5857. **Palacios, G. D.** Diversas clases de hidrocarburos naturales. *Bol. Min. Fom. Venezuela*, año 1, pp. 46-51. [1909.]
5858. **Pally, M. v.** Petroleumschürfungen in Ungarn im Jahre 1900. *Földt. Köz.*, köt. xxxii, pp. 49, 50, 154. [1902.]
5859. **Palibin, N. I.** [Travel-notes on a Journey to Baku.] *Zap. Kark. Old. Imp. Russk. Tekhn. Obsch.*, t. vii, pp. 94-108. [1875.]
5860. — [On the Baku Oil Industry.] *Ibid.*, t. xi, pp. 69-77. [1879.]
5861. **Pallas, P. S.** Reise durch verschiedene Provinzen des Russischen Reiches. 3 Bde. 4to, *St. Petersburg*, 1771, 1773, 1776.
5862. — Bemerkungen auf einer Reise in die südlichen Statthalterschaften des russischen Reiches, 1793-1794. 2 Bde. 4to, *Leipzig*, 1799, 1801.
5863. — Tableau physique et topographique de la Tauride tiré du journal d'un voyage fait en 1794. 4to, *St. Petersburg*, 1795.
5864. — Tableau des Provinces situées sur la côte occidentale de la Mer Caspienne entre les Fleuves Terek et Kour. 4to, *St. Petersburg*, 1798.
5865. — [Mud-eruption on Taman Peninsula] *Nova Acta Ac. Sci. Imp. Petropol.*, t. xii, pp. 44-46. [1801.]
5866. **Pallmann, R.** Petroleum in der Mark Brandenburg. Eine vergleichend geographische Studie. *Berlin*, 1882.
- Palm, O. R.**, see **Mabery, C. F.**
5867. **Palmeri, P.** Sopra una roccia gessosa bituminifera proveniente dal territorio di Savignano. 8vo, *Naples*, 1881.
5868. **Palmieri, L.** Sopra alcune eruzioni fangose avvenute nella Provincia di Cosenza. *Rend. R. Ac. Sci. Napoli*, ser. 3, vol. ix, p. 190. [1870.]
5869. — Notizia di una sorgente di Gas accessibili osservata nella provincia di Ghergenti nel mese di Dicembre del 1870. *Ibid.*, vol. x, pp. 18-20 [1871.]
5870. **Panaitescu, L.** Communication sur la Lampe P. L. *Compt. Rend. Congr. internat. Pétrole*, sess, 3, t. ii, pp. 775-780. [1910.]
5871. **Pantanelli, D.** Su alcuni errori di fatti circa le salse modenese e il petrolio d'Egitto. *Boll. Soc. Geogr. Ital.*, ser. 4, vol. i, pp. 1021-1026. [1900.]
5872. — Le Origini del Petrolio. *Boll. Soc. geol. Ital.*, vol. xxv, pp. 795-802. [1906.]
5873. **Panteliev, N.** [General Analytical Processes in the Petroleum Industry.] *Moscow*, 1903.
5874. **Pantuykhov, N. I.** [The Galician Petroleum Industry.] *Zap. Imp. Russk. Tekhn. Obsch.*, g. xxxii, no. 2, Trudi, pp. 1-23. [1898.]
- Pantuykhov, N. I.**, see **Schukov, A. A.**
- Paolini, V.**, see **Balbiano, L.**
5875. **Pape, J. H.** Von den Therquellen bei Oedemissen. *Schr. k. Soc. Wiss. Göttingen*, bd. i, pp. 64-71. [1771.]
5876. **Papp, C. de.** Source de Méthane à Kíssármás (Comté de Kolozs). *Földt. Köz.*, köt. xl, pp. 306-336; 387-415; pls. i, ii. [1910.]
5877. **Paris, G.**, and **F. Roncali.** Il Petrolio Rumeno del Mercato Italiano. *Chim. Ind.*, t. iv, pp. 370-372. [1902.]
5878. **Parish, E.** On Keroseline, a recently discovered anæsthetic. *Amer. Journ. Pharm.*, ser. 3, vol. ix, p. 396. [1861.]
5879. — On a New Apparatus for Testing Coal Oils. *Trans. Amer. Pharm. Assoc.*, 1862, p. 206.
5880. **Parish, E.** On the Rectification of Petroleum. *Journ. Franklin Inst.*, vol. xci, pp. 117-122. plates. [1871.]
- Pariset**, —, see **Maston**, —.
5881. **Parik, J.** On the probable discovery of Oil and Coal in Wairarapa North County (New Zealand). *Rep. Geol. Surv. N. Zealand*, 1887-88, pp. 20-24, map.
5882. **Parker, E. W.** Asphaltum. *Rep. Min. Ind. U.S.*, 11th Census, 1890, pp. 579-587. [1892.]
5883. — Ozocerite. *Ibid.*, pp. 588-591. [1892.]
5884. — Asphaltum. *Min. Res. U.S.*, 1892, 1900; *Ann. Rep. U.S. Geol. Surv.*, vols. xvi, xix-xxi (parts vi). [1893-1901.]
- Parker, E. W.**, see **Richardson, C.**
5885. **Parker, E. W.** and **T. W. Vaughan.** Asphaltum. 18th *Ann. Rep. U.S. Geol. Surv.*, pt. v. [1897.]
5886. **Parker, W.** On the Progress and Development of Marine Engineering. *Trans. Inst. Naval Archit.*, vol. xxviii, pp. 126-146. [1887.]
5887. **Parkinson, J.** Organic Remains of a Former World. 4to, *London*, 1804.
5888. — On the Existence of Animal Matter in Mineral Substances. *Journ. Nat. Phil. Chem. Arts*, ser. 2, vol. xxii, pp. 218-223. [1809.]
5889. **Parkinson, John.** The Post-Cretaceous Stratigraphy of Southern Nigeria. *Quart. Journ. Geol. Soc.*, vol. lxiii, pp. 308-312. [1907.]
5890. — The Geology of the Oban Hills (Southern Nigeria) [Calabar]. *Ibid.*, pp. 313-316. [1907.]
5891. — The Geology of the West Coast of Africa. *Petroleum World*, vol. vi, pp. 260, 261 [1909.]
5892. — The Age of the Bitumen-bearing Beds of Southern Nigeria. *Ibid.*, vol. vii, p. 322. [1910.]
5893. **Parmentier, F.** Sur un groupe d'eaux minérales fermentant de l'ammoniaque: eaux bitumineuses. *Compt. Rend.*, t. cxxi, pp. 644, 645. [1895.]
5894. **Parr, S. W.**, **B. Mears**, and **D. L. Weatherhead.** Chemical Examination of Asphaltic Material. *Journ. Ind. Eng. Chem.*, vol. i, pp. 761-754. [1909.]
5895. **Parr, S. W.** The Peroxide Calorimeter as applied to European Coals and Petroleum. *Journ. Amer. Chem. Soc.*, vol. xxiv, pp. 167-171. [1902.]
5896. **Parran, A.** Notice sur un gisement d'Asphalte aux environs d'Alais. *Ann. Mines*, sér. 5, t. iv, pp. 334-345, pl. iv. [1853.]
5897. — Sur les divers niveaux de matières combustibles et bitumineuses dans le département du Gard. *Bull. Soc. Géol. France*, sér. 2, t. xxviii, pp. 29-31. [1871.]
5898. **Parrot, G. F.** Expériences sur l'inflammation des gaz combustibles par le contact de corps incandescents. *Ann. Gén. Sci. Phys.*, t. iii, pp. 236, 237. [1820.]
5899. **Parsons, C. L.** Fuller's Earth and its Application to the Bleaching of Oils. *Journ. Amer. Chem. Soc.*, vol. xxix, pp. 598-605. [1907.]
5900. **Parsons, F. W.** Petroleum. *Min. Ind.*, vol. xiv, pp. 468-478. [1906.]
5901. **Parsons, H. G.** The Oil-fields of Kern County, California. *Min. Sci. Press*, vol. lxxxi, pp. 492, 493, 520, 521, 531. [1909.]
5902. **Partridge, E. A.** On the Occurrence of Paraffine in Crude Petroleum. *Journ. Franklin Inst.*, vol. cxvii, pp. 479-484. [1889.]
5903. **Parisch, J.** Die Insel Zante. *Peterm. Mitth.*, bd. xxxvii, pp. 161-174, pl. xii (map. 1: 100,000). [1891.]
5904. **Parisch, P.** Bericht über das Detonations-Phänomen auf der Insel Meleda bei Ragusa, nebst geographisch-historischen Notizen über diese Insel, und einer geognostischen Skizze von Dalmatie. *Hertha*, bd. xi, pp. 93-114. [1824.]
5905. **Pasch, G. E.** Bituminosa Kalksteinbollar. *Jernkont. Ann.*, bt. viii, pp. 240-249. [1824.]
5906. **Paschinin, N. Ph.** [Furnace for burning naphtha after the system of Ing.-Mekh. N. Ph. Paschinin.] *Zap. Imp. Russk. Tekhn. Obsch.*, g. xxix, July, pp. 113-117. [1895.]
- Paschkoff, N. M.**, see **Jordery, C. A.**

5907. **Pascoe, E. H.** The Kabat Anticline, near Seiktein, Myingyan District, Upper Burma. *Rec. Geol. Surv. Ind.*, vol. xxxiv, pp. 242-252, pls. xxxi-xxxiv. [1906.]
5908. — The Asymmetry of the Yenangyat-Singu Anticline. *Ibid.*, pp. 253-260, pl. xxxv. [1906.]
5909. — The Northern Part of the Gweyo Anticline, Myingyan District, Upper Burma. *Ibid.*, pp. 261-265, pls. xxxvi, xxxvii. [1906.]
5910. — Marine Fossils in the Yenangyoung Oilfield (Upper Burma). *Ibid.*, vol. xxxvi, pp. 135-142, pl. xviii. [1908.]
5911. — On the Occurrence of Freshwater Shells of the Genus *Batissa* in the Yenangyoung Oilfield (Upper Burma). *Ibid.*, pp. 143-146, pls. xix, xx. [1908.]
5912. — Note on a Pegu Inlier at Ondwe, Magwe District, Upper Burma. *Ibid.*, vol. xxxviii, pp. 152, 153, pls. iv, v. [1909.]
- Pastrovich, P.**, see **Ulzer, F.**
5913. **Pastukhov, M.**, and **A. Frolov.** [Manufacture of Petroleum-grease and kindred fats from Distillation-Residues.] *St. Petersburg*, 1879.
5914. **Patrick, Prof. G. E.** The Iola Gas Well. *Trans. Kansas Ac. Sci.*, vol. v. [1877.]
5915. **Patrin, E. M. L.** Recherches sur les volcans. *Journ. Phys.*, t. i, pp. 241-267. [1800.]
5916. **Patton, W. F.** Electric Drive for Oil Wells. *Electric Journ.*, vol. viii, pp. 357-365. [1911.]
5917. **Paul, B. H.** Carburation of Gas. *Journ. Soc. Arts*, vol. xi, pp. 503, 520. [1861.]
5918. — On the Manufacture of Hydrocarbon Oils, Paraffin, etc., from Peat. *Chem. News*, vol. vi, pp. 221-223, 243-245. [1862.]
5919. — Artificial Light and Lighting Materials. *Journ. Franklin Inst.*, ser. 3, vol. xviii, pp. 124-132, 203-210. [1864.]
5920. — Use of Petroleum or Mineral Oil as Steam Fuel in place of Coal. *Chem. News*, vol. x, pp. 292, 293; vol. xi, pp. 63-65. [1861, 1865.]
5921. — Petroleum as Fuel. *Journ. Soc. Arts*, vol. xiii, pp. 100, 180. [1865.]
5922. — On Crude Paraffin Oil [from Coal]. *Rep. Brit. Assoc.*, 1864, sect., pp. 36, 37. [1865.]
5923. — On Liquid Fuel. *Journ. Soc. Arts*, vol. xvi, pp. 400-410, 837. [1868.]
5924. — The Mode of Testing Mineral Oils used for Lamps. *Chem. News*, vol. xxi, pp. 2-4. [1870.]
5925. **Paul, F.** Petroleum Development in Russia. *Rep. Cons. U.S.*, vol. xi, pp. 62-64, 1 pl. [1883.]
5926. **Paul, K. M.** Die geologischen Verhältnisse des nördlichen Sáros und Zempliner Comitates. *Jahrb. k.-k. geol. Reichs.*, bd. xix, pp. 256-279. [1869.]
5927. — Das Carpathen-Sandsteingeblet des nördlichen Ungher und Zempliner Comitates. *Ibid.*, bd. xx, pp. 243-250. [1870.]
5928. — Petroleumvorkommen in Nordungarn. *Verh. k.-k. geol. Reichs.*, 1873, pp. 49-51.
5929. — Ueber die Natur des Karpathischen Flysches. *Jahrb. k.-k. geol. Reichs.*, bd. xxvii, pp. 431-452. [1877.]
5930. — Ueber Petroleumvorkommen in der nördlichen Walachei. *Verh. k.-k. geol. Reichs.*, 1881, pp. 93-95.
5931. — Ueber das Ozokerit- und Erdöl-Vorkommen von Boryslaw. *Ibid.*, p. 107.
5932. — Die Petroleum- und Ozokerit-Vorkommnisse Oestgalziens. *Jahrb. k.-k. geol. Reichs.*, bd. xxxi, pp. 131-168. [1881.]
5933. — Geologische Notizen aus der Moldau. *Verh. k.-k. geol. Reichs.*, 1882, pp. 316, 317.
5934. — Die neueren Fortschritte der Karpathen-sandstein-Geologie. *Jahrb. k.-k. geol. Reichs.*, bd. xxxiii, pp. 659-691, sections. [1883.]
5935. — Zur Geologie des Westgalizischen Karpathen. *Verh. k.-k. geol. Reichs.*, 1886, pp. 134-137.
5936. — Gutachten über das Vorkommen von Nafta (Petroleum oder Bergöl) in Zempliner Comitete, namentlich in Kriva-Olyka, und Hankovce. *Ung.-Montan-Ind. Zeitung*, 1887, no. 15.
5937. **Paul, K. M.**, and **E. Tietze.** Neue Studien in der Sandsteinzone der Karpathen. *Jahrb. k.-k. geol. Reichs.*, bd. xxix, pp. 189-304. [1879.]
5938. **Pauli, R.** Vergleichende Bestimmung der Paraffine verschiedener Schmelzpunkte im Braunkohlentheer. *Chem.-Zeit.*, bd. xxiv, pp. 754, 755. [1900.]
5939. **Pautinsky, M.** [Chemistry of Caucasian Petroleum.] *Svo. Moscow*, 1886.
5940. **Pavelesco, F.** [Oil Workings at Balcoiu.] *Monit. Int. Pétr. Roum.*, t. vii, p. 457. [1906.]
5941. — [Description of the Campina-Bustenari-Faget-Doftanetz Oilfield.] *Ibid.*, pp. 771-778. [1906.]
5942. **Pavesi, A.** Analisi dell' acqua dei pozzi a petrolio di Rivanazzano. *Rend. R. Ist. Lomb.*, t. iv, pp. 590-592. [1871.]
5943. **Pawlewski, B.** [Galician Petroleum.] *Kosmos*, 1885, pp. 323-332. .
5944. — Ueber das Vorkommen des Paraxylols im galizischen Petroleum. *Ber. deutsch. chem. Ges.*, bd. xviii, pp. 1913, 1916. [1885.]
5945. — Zur Kenntniss von Paraffin. *Ibid.*, bd. xxiii, pp. 327-329. [1890.]
5946. — [On the Optical Activity of Petroleum Products.] *Chemik (Warsaw)*, 1905, p. 337.
5947. **Pawlewski, B.**, and **J. Filemonowicz.** Ueber die Löslichkeit und Bestimmung von Paraffin. *Ber. deutsch. chem. Ges.*, bd. xxi, pp. 2973-2976. [1888.]
5948. **Payan, A.** Mémoire sur les bitumes, leur exploitation, et leurs emplois utiles. *Svo, Paris*, 1824.
5949. — Rapport . . . , au nom du Comité des arts chimiques, sur divers ouvrages en bastic bitumineux, de MM. Pillot et Eyquem. *Bull. Soc. Encour.*, t. xxiii, pp. 169-173. [1824.]
5950. — Note sur le schiste bitumineux et le lignite d'Ardes. *Ann. Chim. Phys.*, sér. 2, t. xxix, p. 335. [1825.]
5951. — Sur les Fumivores de M. Bourguignon; suivi de recherches expérimentales sur les quantités variables de lumière produites par la combustion complète de l'hydrogène carboné, de l'huile, etc., et de la théorie de ces variations. *Bull. Soc. Encour.*, t. xxvi, pp. 22-30. [1827.]
5952. — Huile de Pétrole. Huiles lourdes des goudrons de houille. *Ann. Conserv. Arts Mét.*, [sér. 1], t. viii, pp. 50-66. [1868.]
5953. **Payen, A.**, and **J. S. E. Julia de Fontenelle.** Extrait d'une Note sur le Charbon de Schiste bitumineux. *Journ. Pharm.*, sér. 2, t. ix, pp. 462-466. [1823.]
5954. **Payton, C. A.** Report for the year 1895 on the Trade of Genoa. *Dipl. Cons. Rep.*, ann. ser., no. 1723. [1896.]
5955. **Pazar, S.** Naturgas in Ungarn. *Organ. Ver. Bohrechn.*, bd. xii, 1905.
5956. **Peabody, C. H.** Marine Gasoline and Gas Engines as used in Modern Motor Boats. *Marine Engineering*, vol. ii, 1898, June, pp. 6-10; August, pp. 6-9; September, pp. 2-10.
5957. **Peabody, E. H.** Oil Fuel. *Journ. Amer. Soc. Naval Eng.*, vol. xxiii, pp. 489-499. [1911.]
5958. **Peacham, H.** The Valley of Variette' or, Discourse fitting for the Times, containing very learned and rare Passages out of Antiquity, Philosophy, and History. 16mo, London, 1638.
5959. **Peacock, D. E.** Petroleum Districts of the Kouban (Caucasus). *Rep. Cons. U.S.*, no. 1, pp. 159-173. [1880.]
5960. — Report on the Petroleum Trade of Baku, and Batoum as its future outlet. *Rep. Cons. Man. Comm.*, etc., 1882, pp. 1094-1098.
5961. — Reports on the Trade of Batoum for the years 1887, 1889, 1890. *Dipl. Cons. Rep.*, ann. ser., nos. 346, 677, 871. [1888, 1890, 1891.]
5962. **Peale, A. C.** Geological Report on the Grand River District [Utah and Colorado]. *Tenth Ann. Rep. U.S. Geol. Surv. Territories*, pp. 161-186, pls. viii-xii. [1878.]
5963. **Pearse, J. P.**, and **F. Platt.** A Report on the Use of Natural Gas in the Iron Manufacture. *2nd Geol. Surv. Pennsylvania*, L, app. D, pp. 173-216. [1887.]

5964. **Pearson, F. W.** *Petróleo. Bol. Soc. Nac. Minería Chile*, ser. 3, t. xix, pp. 126-128. [1907.]
5965. **Pearson, H.** Argentine and its Oil Resources. *Petrol. World*, vol. v, pp. 100-102. [1908.]
5966. **Pearson, E.** The Discovery of Natural Gas in Sussex: Heathfield District. *Trans. Inst. Min. Eng.*, vol. xxvi, pp. 494-503. [1904.]
5967. **Peasegood, W. G.** Discharge of Inflammable Oil in a Coal-seam [Staffordshire]. *Ibid.*, vol. xxxv, pp. 116-120. [1908.]
5968. **Pebal, L.** Untersuchung des galizischen Steinöls. *Ann. Chem. Pharm.*, bd. cxv, pp. 19-23. [1860.]
5969. ——— Analyse eines brennbaren Gasgemisches aus dem Salzbergwerke von Wieliczka. *Ibid.*, bd. cxviii, pp. 27-32. [1861.]
5970. **Peckham, H. E.** On the Bituminous Deposits situated at the south and east of Cardenas, Cuba. *Amer. Journ.*, ser. 4, vol. xii, pp. 33-41. [1901.]
- Peckham, H. E.**, see **Peckham, S. F.**
5971. **Peckham, S. F.** On the supposed falsification of Samples of Californian Petroleum. *Amer. Journ.*, ser. 2, vol. xliii, pp. 345-351. [1897.]
5972. ——— On a new Apparatus for Technical Analysis of Petroleum and Kindred Substances. *Ibid.*, ser. 2, vol. xliii, pp. 230-235. [1897.]
5973. ——— On the Distillation of dense Hydrocarbons at high Temperatures, technically termed "cracking." *Ibid.*, ser. 2, vol. xlvii, pp. 9-16. [1899.]
5974. ——— Notes on the Origin of Bitumens, together with Experiments upon the Formation of Asphaltum. *Rep. Geol. Surv. Calif.*, vol. ii, pp. 73-90. [1869.]
5975. ——— On the probable Origin of Albertite and allied Minerals. *Amer. Journ.*, ser. 2, vol. xlviii, pp. 362-378. [1899.]
5976. ——— The Production, Technology and Uses of Petroleum. *Washington*, 1874.
5977. ——— American Asphaltum. *Amer. Chem.*, vol. iv, pp. 6-9. [1874.]
5978. ——— Notes on the Ultimate Analysis of Crude Petroleum. *Ibid.*, vol. vii, pp. 327, 328. [1877.]
5979. ——— On the Determination of Specific Gravities. *Chem. News*, vol. xxxix, pp. 97, 98. [1879.]
5980. ——— Examination of the bituminous substances occurring in Southern California. *California Geol. Survey*, vol. ii, appendix, pp. 49-90. [1882.]
5981. ——— The Origin of Bitumens. *Amer. Journ.*, ser. 3, vol. xxviii, pp. 105-117. [1884.]
5982. ——— Report on the Production, Technology, and Uses of Petroleum and its Products (Tenth Census). *Quart. Rep. U. S. Bureau of Statistics*, vol. x. [1886.]
5983. ——— Petroleum. Eleventh Census Report. *Washington*, 1892.
5984. ——— Petroleum in its Relations to Asphaltic Pavement. *Amer. Journ.*, ser. 3, vol. xvii, pp. 29-34. [1894.]
5985. ——— On the Nitrogen Content of California Bitumen. *Ibid.*, vol. xviii, pp. 250-255. [1894.]
5986. ——— On the Origin of Bitumens. A Retrospect. *Ibid.*, pp. 388-395. [1894.]
5987. ——— Petroleum in Southern California. *Science*, vol. xxiii, pp. 74, 75. [1894.]
5988. ——— On the Pitch Lake of Trinidad. *Amer. Journ.*, ser. 3, vol. i, pp. 33-51. [1895.]
5989. ——— What is Bitumen? *Journ. Franklin Inst.*, vol. cxi, pp. 370-383. [1895.]
5990. ——— The Asphalt Question. *Journ. Amer. Chem. Soc.*, vol. xvii, pp. 55-63. [1895.]
5991. ——— On the Use of Acetone in the Technical Analysis of Asphaltum. *Journ. Franklin Inst.*, vol. cxii, pp. 219-223. [1896.]
5992. ——— On the Nature and Origin of Petroleum. *Proc. Amer. Phil. Soc.*, vol. xxxvi, pp. 103-112. [1897.]
5993. ——— The Genesis of Bitumens as related to Chemical Geology. *Ibid.*, vol. xxxvii, pp. 108-139. [1898.]
5994. ——— The Technology of Californian Bitumens. *Journ. Franklin Inst.*, vol. cixvi, pp. 45-54. [1898.]
5995. **Peckham, S. F.** On the Technical Analysis of Asphaltum and Asphaltes. *Journ. Soc. Chem. Ind.*, vol. xvii, pp. 438, 439. [1898.]
5996. ——— Notes upon Asphalt and Asphaltum. *Ibid.*, pp. 1003-1005. [1898.]
5997. ——— What is Parianite? *Journ. Franklin Inst.*, vol. cxlix, pp. 161-193. [1900.]
5998. ——— Concerning Retene, Petrolene and Asphaltene. *Ibid.*, vol. cli, pp. 50-61. [1901.]
5999. ——— On the Classification of Crude Petroleum. *Ibid.*, pp. 114-124. [1901.]
6000. ——— Solid Bitumens. 8vo, *New York*, 1909.
6001. **Peckham, S. F.**, and **L. A. Linton.** On Trinidad Pitch. *Amer. Journ.*, ser. 4, vol. i, pp. 193-207. [1896.]
6002. **Peckham, S. F.**, and **H. E. Peckham.** Analysis of Asphalt. *Journ. Soc. Chem. Ind.*, vol. xvi, pp. 424-427. [1897.]
6003. ——— On the Sulphur Content of Bitumens. *Ibid.*, pp. 996-998. [1897.]
6004. ——— The Determination of Sulphur in Bitumens. *Journ. Amer. Chem. Soc.*, vol. xxi, pp. 772-776. [1899.]
6005. **Peet, C. A.** Green River Oil Fields in Wayne County, Utah. *Salt Lake Min. Rev.*, vol. xi, no. 18, pp. 19-21. [1909.]
6006. **Pelatan, L.** Les Richesses minérales des Colonies Françaises. 8vo, *Paris*, 1902.
6007. **Péligot, H.** Lampes servant à l'éclairage au moyen des huiles animales, végétales ou minérales. *Rapp. Journ. internat. Expos. Univ. Paris*, 1867, cl. 24, sect. 4, pp. 367-385. [1868.]
6008. **Pellati, N.** Relazione Generale [sul Servizio Minerario nel 18 .]. *Ann. Agric. Rel. Serv. Min.*, 1880-1891. [1883-1893.]
6009. **Pelle, M.** Études sur les salines de Roumanie. *Ann. Mines*, sér. 3, t. x, pp. 270-310, pls. iii, iv. [1886.]
6010. **Pellet, H.** De quelques composés de la paraffine. *Compt. Rend.*, t. lxxiv, pp. 1576-1579. [1872.]
6011. **Pellet, H. M.** Dosage du soufre dans les pyrites, les mattes, scories, houilles, bitumes, etc. *Ann. Chim. anal. appl.*, t. vi, pp. 281-285. [1901.]
6012. **Pelletier, J.**, and **P. Walter.** Sur les Bitumes. *Journ. Pharm.*, t. xxvi, pp. 549-568. [1840.]
6013. **Pelouze, J.**, and **A. Cahours.** Recherches sur les Pétales d'Amérique. *Compt. Rend.*, t. lvi, pp. 505-513; t. lvii, pp. 62-69. [1863.]
6014. **Peltzer, R.** Ueber die Entflammbarkeit des Petroleum und des Schieferöles. *Polyt. Journ.*, bd. cxxxix, pp. 61-63. [1868.]
6015. **Pemberton, W. W.**, etc. Record of Gas and Mud Eruptions on the Arakan Coast on 12th March 1876 and in June 1843. *Rec. Geol. Surv. India*, vol. xiii, pp. 206-209. [1890.]
6016. **Penny, F.** Report on the Chemical Qualities and Analysis of a Combustible Mineral Substance from the Mersey River, Tasmania. *Proc. R. Soc. Van Diemen's Land*, vol. iii, pp. 108-115. [1855.]
6017. **Perard, J.** De l'emploi des Moteurs à Pétrole à bord des Bateaux de Pêches. *Mém. Soc. Ing. Civ.*, 1903, t. i, pp. 468-485.
6018. **Perceval, C. A. S.** Report for the year 1909 on the Trade and Commerce of the Consular District of Galveston. *Dipl. Cons. Rep.*, ann. ser., no. 4425. [1910.]
6019. ——— Petroleum Output in Texas. *Board of Trade Journ.*, vol. lxxiii, p. 527. [1911.]
6020. **Perceval, J. G.** Report on the Geology of the State [of Connecticut]. 8vo, *Newhaven*, 1842.
6021. ——— "Indurated Bitumen" in Cavities of the Trap of the Connecticut Valley. *Amer. Journ.*, ser. 3, vol. xvi, pp. 130-132. [1878.]
- Perceval, J. G.**, see **Jackson, C. T.**
6022. **Perl, E.** Die Beleuchtungstoffe und deren Fabrikation. . . . *Vienna*, 1876.
6023. **Peron, A.** Essai d'une Description Géologique de l'Algérie. *Ann. Sci. Géol.*, t. xiv. [1882.]

6024. **Peron, F. A., and L. Freycinet.** Voyage de Découvertes aux Terres Australes, sur les Corvettes le *Geographe*, le *Naturaliste*, et la Goélette la *Casuarina*, pendant les années 1800-1804. 4to, Paris, 1807-1816.
- Perrin, —**, see **Harris, E.**
6025. **Perry, J.** The Steam Engine, and Gas and Oil Engines. 8vo, New York, 1899.
6026. **Perschke, L. L.** [Industries of the Transcaucasian Provinces.] 1902.
6027. **Perutz, H.** Moyen pour utiliser les alkalis et les acides employés à l'épuration des huiles minérales. *Technol.*, t. xx, p. 519. [1859.]
6028. — Wiedergewinnung der Alkalien und Säuren, welche in Mineralöl-fabriken zum Reinigen der Oele benutzt worden sind. *Polyt. Journ.*, bd. cxliii, p. 65 [1862.]
6029. — Ueber Petroleum. *Verh. Polyt. Ges. Berlin*, bd. xxiv, pp. 126-138. [1863.]
6030. — Die Industrie der Fette. 8vo, Berlin, 1866.
6031. — Die Industrie der Mineralöle, des Petroleums, Paraffins und der Harze, nebst sämtlichen damit zusammenhängenden Industriezweigen. 8vo, Vienna, 1868.
6032. — Ueber die Entfernung der nach der Raffination der Mineralöle zurückbleibenden letzten Spuren Schwefelsäure, sowie des Schwefels der in dem Rohöl enthaltenen Schwefelverbindungen durch Natron und Kalkhydrat. *Chem.-Zeit.*, bd. iv, p. 271. [1880.]
6033. **Perutz, K.** Zur Geschichte der Erdölgruben in Rogi [Galizien]. *Naphtha*, bd. xii, pp. 243-247. [1904.]
6034. **Pervinquière, L.** La Genèse des Pétaoles. *Rev. Sci. (Paris)*, sér. 5, t. ix, pp. 389-393. [1908.]
6035. **Pesterev, P.** [Experiments in Oil-gas Illumination in the Lagan Works.] *Gorn. Journ.*, 1869, t. 1, pp. 159-168.
6036. **Peter, R.** Chemical Reports of the Minerals, Rocks and Soils [of Kentucky]. 1st, 2nd and 3rd Rep. *Geol. Surv. Kentucky*, 1854-1857.
6037. **Petersen, —**. Ueber den Erdharz von Baku. *Ann. Chem. Pharm.*, bd. cxviii, pp. 82-84. [1861.]
6038. **Peterson, F. P.** Die Erzeugung von Gasolin aus Naturgas. *Petroleum Zeitschr.*, bd. vi, pp. 2179-2182. [1911.]
6039. **Petit, V.** Verfahren und Vorrichtung zum Heben von Flüssigkeiten aus Schächten, Bohrlöchern und dergl. mittels Druckluft. *Naphtha*, bd. x, pp. 63-68. [1902.]
6040. — Ueber Röhrenheber. *Ibid.*, pp. 107-111. [1902.]
6041. — Ueber Bohrgestänge und Fanglocken. *Ibid.*, pp. 169-172. [1902.]
6042. — Guide du Soudeur au Pétrole. Paris, 1907.
6043. — [Flush-Drilling.] *Ropa*, 1911, no. 8.
6044. **Petitot, E. F. S.** On the Athabasca District of the Canadian Northwest Territory. *Proc. R. Geogr. Soc.*, n.s., vol. v, pp. 633-655. [1883.]
6045. **Petrascheck, W.** Das Vorkommen von Erdgasen in der Umgebung des Ostrau-Karwiner Steinkohlenreviers. *Verh. k.-k. geol. Reichs.*, 1908, pp. 307-312.
6046. **Petresano, —**. A new Incandescent Petroleum Lamp. 1st Internat. Petrol. Congr., pp. 79, 80. [1900.]
6047. **Petrie, J. M.** The Mineral Oil from the Torbanite of New South Wales. *Journ. Soc. Chem. Ind.*, vol. xxiv, pp. 996-1002. [1905.]
6048. **Petroni, C. T.** Analize de petroluri. *An. Inst. Geol. Rom.*, vol. I, pp. 396, 397; vol. II, pp. 474-478. [1908.]
6049. — Les coefficients de dilatation des pétroles bruts de Roumanie et de leurs dérivés. *Ibid.*, vol. III, pp. 524-534. [1910.]
6050. — Étude comparative entre les points d'inflammabilité des pétroles lampants déterminés à l'aide des appareils Abel-Pensky et Granior. *Ibid.*, pp. 539-545. [1910.]
6051. **Petrov, N. P.** [Remarks on the Exhibits in the Division of Lubricating Materials.] *Zap. Imp. Russk. Tekhn. Obsch.*, g. xxii, otd. I, pp. 127-131. [1888.]
6052. **Pettersson, A.** Om flytande bräusle. *Jernkont. Ann.*, n.s., bt. Ix, pp. 137-186. [1905.]
6053. **Petunnikov, A. N.** [Asphalt.] *Priroda*, kn. II, otd. I, p. 217. [1876.]
6054. **Petzholdt, A.** Ein neuer brennbares Mineral aus Ehsland. *Journ. prakt. Chem.*, bd. II, pp. 112, 113. [1850.]
6055. **Pfankuch, F.** Neue Bildungsweisen von Kohlenwasserstoffen. *Ibid.*, bd. cxii, pp. 35-37. [1871.]
6056. **Pfeifer, J.** Ueber die Bedeutung der natürlichen Erdgase Ungarns. *Chem.-Zeit.*, bd. xxxii, p. 9. [1908.]
6057. **Pfeiffer, G.** [Caciulata Gas-spring, on Olt River.] *Bull. Assoc. Scienc. Bucharest*, t. III, 1904.
- Pfeiffer, G.,** see **Edeleann, L.**
6058. **Pfeiffer, O.** Das Gas als Leucht-, Heiz- und Kraftstoff in seinen verschiedenen Arten als Steinkohlengas, Holz und Torfgas, Oelgas, Wassergas, Fabrikation und Verwendung. 8vo, (atlas fol), Weimar, 1896.
6059. **Ph. (φ).** Die Erdöl-Industrie in Japan. *Chem.-Zeit.*, bd. xxiii, pp. 193, 194. [1899.]
6060. **Phalen, W. C.** Economic Geology of the Kenova Quadrangle, Kentucky, Ohio, and West Virginia. *Bull. U.S. Geol. Surv.*, no. 349. Pp. 158; 6 pls. [1908.]
6061. **Phenis, A.** The Oil-fields of Texas. *Manuf. Rec.*, 1903.
6062. **Philemonovitch, Ya. V.** [The Estimation of Paraffin in Petroleum.] *Zap. Imp. Russk. Tekhn. Obsch.*, g. xxiv, Jan., pp. 31-37. [1890.]
6063. **Philippi, E.** Ueber natürliche Bildung von Erdöl. *Nat. Wochenschr.*, 1904.
6064. **Philippov, N.** [Description of Baku and Its Roadstead.] *Morsk. Sborn.*, 1856, pp. 146-164.
6065. — [Journey to the Sea of Azov in 1856. Structure of the Ketch and Taman Peninsulas, Oil-springs, Temriuk, Ekaterinodar.] *Ibid.*, 1857, nos. 5, 8, 10.
6066. — [Volcanic Part of the Caspian Sea.] *Ibid.*, 1877, no. 3, p. 14.
6067. **Phillipson, A.** Der Peloponnes. Versuch einer Landeskunde auf geologischer Grundlage. 8vo, Berlin, 1892.
6068. **Phillips, F. C.** Report on the Chemical Composition of Natural Gas. *Ann. Rep. Geol. Surv. Penns. for 1886*, pt. II, pp. 787-827.
6069. — The Composition of Fuel; Value of Natural Gas. 8vo, Harrisburg, 1887.
6070. — Researches upon the Phenomena of Oxidation and Chemical Properties of Gases, V.: Composition of Natural Gas. *Amer. Chem. Journ.*, vol. xvi, pp. 406-429. [1894.]
6071. — Notes on the Chemical Composition of Natural Gas from Great Salt Lake. *Proc. Eng. Soc. West. Penns.*, vol. xiii, pp. 453-456. [1897.]
6072. — Fluctuations in the Composition of Natural Gas; and a Method for the Determination of Nitrogen in Gas Mixtures. *Ibid.*, vol. xiv, pp. 290-307. [1898.]
6073. — Researches upon the Chemical Properties of Gases. *Trans. Amer. Phil. Soc.*, vol. xvii, pp. 149-236. [1897.]
6074. — On the Genesis of Natural Gas and Petroleum. *Proc. Amer. Phil. Soc.*, vol. xxxvi, pp. 116-121. [1897.]
6075. — On the Occurrence of Petroleum in the Cavities of Fossils. *Ibid.*, pp. 121-126. [1897.]
6076. — On Fluctuations in the Composition of Natural Gas. *Proc. Amer. Acad.*, vol. xxxiv, pp. 71-83. [1893.]
6077. — On the Occurrence of Hydrogen Sulphide in the Natural Gas of Point Abino, Canada; and on a Method for the Determination of Sulphur in Gas Mixtures. *Journ. Amer. Chem. Soc.*, vol. xx, pp. 696-705. [1893.]

6078. **Phillips, H. J.** Engineering Chemistry: a Practical Treatise comprising methods of analysis and valuation of the principal materials used in engineering work, with numerous analyses, examples, and suggestions. 12mo, London, 1891.
6079. **Phillips, W.** An Elementary Introduction to the Knowledge of Mineralogy. 8vo, London, 1816.
6080. **Phillips, W. B.** The Beaumont Oil Field, Texas. *Eng. Min. Journ.*, vol. lxxi, pp. 175, 176. [1901.]
6081. — Texas Petroleum. *Univ. Texas Min. Surv. Bull.*, no. 1. [1901.]
6082. — Sulphur, Oil and Quicksilver in Trans-Pecos Texas. *Ibid.*, no. 2. [1902.]
6083. — Coal, Lignite and Asphalt Rocks [Texas]. *Ibid.*, no. 3. [1902.]
6084. — The Mineral Resources of Texas. *Bull. Texas Dept. Agric.*, no. 14. Pp. 45; 7 pls. [1910.]
6085. — Petroleum in Texas. *Eng. Min. Journ.*, vol. xciii, pp. 97, 98. [1912.]
6086. **Phinney, A. J., and W. J. McGee.** The Natural Gas Field of Indiana. *Ann. Rep. U.S. Geol. Surv.*, vol. xi, pp. 579-742, pls. lxii-lxvi. [1891.]
6087. **Phleps, O.** Geologische Notizen über die im Becken Siebenbürgens beobachteten Vorkommen von Naturgasen, mit besonderer Berücksichtigung der Möglichkeit des damit verbundenen Petroleum-vorkommens. *Ung. Mont. Ind. Zeit.*, 1904, no. 7, pp. 5, 6; no. 8, pp. 1-3.
6088. — Ein Petroleumvorkommen in Siebenbürgen. *Petroleum Zeitschr.*, bd. i, pp. 296-300. [1906.]
- Phlerow**, —, see **Istomin**.
6089. **Phollendorf, N.** [Gas-making Apparatus (Hirzel's) and the Use of Petroleum Residues for Illuminating Gas.] *Gorn. Journ.*, 1875, t. 2, pp. 73-82.
- Piccini, A.**, see **Gibertini, D.**
6090. **Pichler, A.** Zur Geognosie der nordöstlichen Kalkalpen Tirols. *Jahrb. k.-k. geol. Reichs.*, bd. vii, pp. 717-738, map. [1856.]
6091. — Beiträge zur Geognosie Tirols. *Zeitschr. Innsbruck. Ferdinandeums*, bd. xi, pp. 1-48; bd. xii, pp. 3-17; *Jahrb. k.-k. geol. Reichs.*, bd. xvi, pp. 501-504; bd. xviii, pp. 45-52; bd. xix, pp. 211-216; bd. xx, pp. 273, 274. [1863-1870.]
6092. **Pichler, F.** Einiges aus der amerikanischen Gasindustrie. *Journ. Gasbeleucht.*, bd. xlvii, pp. 942, 943. [1904.]
6093. **Pickwell, R.** Petroleum-Storage Installations at Avonmouth and at Cardiff. *Proc. Inst. Civ. Eng.*, vol. civ, pp. 249-258, pls. vii, viii. [1891.]
6094. **Picot, J.** Statistique de la Suisse. *Geneva*, 1819.
6095. **Piddington, H.** Examination and Analysis of a Soil brought from the Island of Chedooha. *Journ. As. Soc. Beng.*, vol. x, pp. 436-448. [1841.]
6096. — On a New Kind of Coal, being Volcanic Coal from Arracan. *Ibid.*, vol. xvi, pp. 371-373. [1847.]
6097. **Piedboenf, J. L.** Petroleum Central-Europa's, wo und wie es entstanden ist, mit specielle Anwendung auf die deutsche Petroleum-Industrie. 8vo, Düsseldorf, 1883.
6098. — Notice sur les Gisements Pétrolières de l'Europe centrale, et étude spéciale des gisements du Nord d'Allemagne. *Rev. Univ. Mines*, sér. 2, t. xiii, pp. 57-76, 611-654, pls. 2, 4-26. [1883.]
6099. — Apropes des fossiles d'Oelheim. *Ann. Soc. Géol. Belg.*, t. xiii, pp. cli, clii. [1886.]
6100. — [Petroliferous Concretions in Gault of Hanover, possibly derivative from Lias.] *Ibid.*, t. xvi, pp. xxviii, xxix. [1888.]
6101. **Piek**, —. Die Oelfenerungen in Schmiede betrieb. *Vienna*, 1909.
6102. **Pierce, W. P.** Asphalt of Trinidad. *Rep. Cons. U.S.*, vol. xi, pp. 169-239. [1892.]
6103. **Piestrak, F.** Kohlenwasserstoffgase in der Salzgrube in Wieliczka. *Oesterr. Zeitschr. Berg-Hütt.*, bd. ii, pp. 122-124. [1903.]
6104. **Pietrusky, K.** Die Petroleumindustrie in den Vereinigten Staaten in Jahren 1905-1907. *Petroleum Zeitschr.*, bd. i, pp. 401-404; bd. iii, pp. 481-485, 630-633, 735-738; bd. iv, pp. 864-871; bd. v. pp. 825-828. [1906-1910.]
6105. — Ueber Rohölfenerung in den Vereinigten Staaten von Amerika. *Zeitschr. angew. Chem.*, bd. xxiv, pp. 1518-1520. [1911.]
6106. **Pigniol de la Force, J. A. de.** Description Historique et Géographique de la Franco. 13 Tt. 12mo, Paris, 1752-1754.
6107. **Pihan, A.** Description des Appareils et de la Méthode d'Essai. *Compt. Rend. Congr. internat. Pétrole*, sess. 3, t. ii, pp. 781-792. [1910.]
- Pihan, A.**, see **Guilbert**, —.
6108. **Pilat, S. v.** Progress in the Manufacture of Lubricating Oils in 1910. *Petrol. World*, vol. viii, pp. 178, 179, 260. [1911.]
6109. **Pilat, S. v., and L. Singer.** Die Technologie des Erdöls und seiner Produkte. *Petroleum Zeitschr.*, bd. vii, pp. 229-234. [1911.]
6110. **Pilat, S. v., and W. Starke.** Zur kenntnis der Abfallschwefelsäure der Mineralöhräfinerien. *Ibid.*, bd. vi, pp. 2177-2179. [1911.]
- Pilat, S. v.**, see **Hausmann, L.**
6111. **Pile, D. W. H.** On the Specific Gravities indicated by Baumé's Hydrometer. *Trans. Amer. Pharm. Assoc.*, 1870, p. 153.
6112. **Pilenko**, —. [Report on Oil-shows in the Taman Peninsula and Kuban Province.] 1867.
6113. **Pilgrim, G. E.** The Geology of the Persian Gulf and the adjoining portions of Persia and Arabia. *Mem. Geol. Surv. Ind.*, vol. xxxiv, pt. 4. Pp. 178; 17 pls. [1908.]
6114. **Pilide, C. D.** Ueber das Neogen-Becken nördlich von Floeschi (Walachei). *Jahrb. k.-k. geol. Reichs.*, bd. xxvii, pp. 131-142. [1877.]
6115. **Pilkington, J.** A View of the Present State of Derbyshire; with an Account of its most remarkable Aftiquities. 2 vols. 8vo, London, 1789.
6116. **Pilla, L.** Sopra la produzione delle fiamme ne' Vulcani, e sopra le conseguenze che se ne possono tirare. *Mus. Lett. Fil.*, ser. 2, t. ii, pp. 211-236. [1843.]
6117. — Aggiunte alla scrittura sopra la produzione de fiamme ne' Vulcani. *Ibid.*, t. v, pp. 152-166. [1845.]
6118. **Pilingen, M. Z.** De Bitumine et Ligno Fossilii Bituminoso. 12mo, Alenburgh, 1674.
6119. **Pilo, M.** Le Salse dell' Emilia. *Reggio*, 1882.
6120. **Pilts**, —. [On Natural Asphalt as Building Material.] *Zap. Imp. Russk. Tekhn. Obsch.*, g. iv, otd. iii, pp. 316-324. [1870.]
6121. **Pine, J. M.** [Gilsonite of the Uintah Basin, Utah.] *Mining World*, vol. xxiii, p. 610. [1906.]
6122. **Pinckenburg, G.** Nachmals die Frage der künstlichen Stampfasphalte. *Asphalt-Teerind.-Zeit.*, bd. v, pp. 204, 223, 224. [1905.]
6123. **Pinner, A.** Ueber einen Kohlenwasserstoff C<sub>2</sub>H<sub>2</sub>. *Her. deutsch. chem. Ges.*, bd. viii, pp. 899-902. [1875.]
6124. **Pianno**, —. Bemerkungen über das Vorkommen und die Verwertung der Boghead-Kohle und der öfiführenden Schiefer in Schottland. *Zeitschr. Berg-Hütt.-Salinenv. preuss. St.*, bd. xxxiv, pp. 129-132. [1886.]
6125. **Pinzas, E. J.** La Minería en la Provincia Dos de Mayo. *Bol. Ministr. Fom. Peru*, t. i, no. 11, pp. 32-44. [1903.]
6126. — La Minería en Huallanca. *Ibid.*, no. 12, pp. 37-53. [1903.]
6127. **Piret, F. M.** La fontaine ardente de Saint-Barthélemy (Isère). Gas naturel, Charbon, Pétrole. 8vo, Grenoble, 1881.
- Pirondi**, —, see **Combes**, —.
6128. **Pirotski, Ph. A.** [On Stoves, Russian and Room-, and the use in them of Mineral Fuel.] *Zap. Imp. Russk. Tekhn. Obsch.*, g. xv, otd. i, pp. 336-362, 3 pls. [1881.]

6129. **Pisanello, G.** Sull' analisi dei naftetini. *Compt. Rend. Congr. internat. Chim Appl.*, sess. 6, t. 1, pp. 250-254. [1907.]
6130. **Piterski, Za. M.** [Control of Oil-Fountains.] *Gorn. Journ.*, 1908, t. 2, pp. 215-220.
6131. **Pittet, H.,** see **Defays, J.**
6132. **Pittman, E. F.** Geological Survey of New South Wales. The Mineral Resources. 8vo, Sydney, 1901.
6132. ——— Report of the Under-Secretary of Mines for the year 1902. *Ann. Rep. Dep. Mines N.S. Wales*, 1902-1910. [1903-1911.]
6133. **Plant, John.** Bog Butter (Butyrellite) from Co. Galway, Ireland. *Proc. Manch. Lit. Phil. Soc.*, vol. xix, pp. 70, 71. [1880.]
6134. **Platania, G.** Origine della Timpa della Scala. Contributo allo Studio dei Burroni vulcanici. *Boll. Soc. Geol. Ital.*, vol. xxiv, pp. 451-460. [1905.]
6135. **Platonov, K. S.** [Materials for the Study of the Existing Conditions of Output and Consumption of Petroleum Products abroad and in Russia.] *Baku*, 1903.
6136. **Platsch, M.** Die Petroleumindustrie in Elsass nnd in Hannover (8 Vers. deutsch. Chem.). *Petroleum Zeitschr.*, bd. 1, pp. 645-649. [1906.]
6137. ——— Aus dem hannoverschen Oelbohrbetriebe. *Chem.-Zett.*, bd. xxx, pp. 766, 767. [1906.]
6138. **Platt, F.** Report of Progress in the Clearfield and Jefferson District of the Bituminous Coalfields of Western Pennsylvania. *2nd Geol. Survey Penns.*, H. 8vo, Harrisburg, 1876.
6139. ——— Durability of the Natural Gas Supply. *Ibid.*, L, app. C, pp. 161-172. [1876.]
6140. **Platt, F.,** and **W. G. Platt.** Report of Progress in Cambria County. *2nd Geol. Surv. Pennsylvania*, HH. [1877.]
6141. **Platt, J.** Tests of Oil and Coal as Fuel on Hydraulic Lifeboat Queen. *Marine Engineering*, vol. ii, Sept. 1898, pp. 21-24.
6142. **Platt, W. G.** Report of Progress in Indiana County, 1877. *2nd Geol. Survey Penns.*, H4. 8vo, Philadelphia, 1878.
6143. ——— Report of Progress in Armstrong County. *Ibid.*, H5. 8vo, Harrisburg, 1880.
6144. ——— Report of Progress in Jefferson County. *Ibid.*, H6. 8vo, Harrisburg, 1881.
6144. **Platt, W. G.,** see **Platt, F.**
6145. **Platz, G.** Die Naphthainzel Tscheken. *Petroleum Zeitschr.*, bd. v, pp. 821-824. [1910.]
6146. **Platz, H.** Beitrag zur Frage der Wasserabsperrung in den Exploitationsbohrlochern des Petroleumgebiete. *Chem. Rev. Fett-Harz-Ind.*, bd. x, pp. 32, 33. [1903.]
6147. **Playfair, L.** On the Gases evolved during the Formation of Coal. *Mem. Geol. Surv. Gr. Britain*, vol. i, pp. 460-479. [1846.]
6148. ——— On Three Important Chemical Discoveries from the Exhibition of 1851:— . . . . . Young's Paraffine and Mineral Oil from Coal: . . . . . *Proc. R. Inst.*, vol. i, pp. 131-138. [1852.]
6149. **Plock, D.** Die Erdöl-Industrie Deutschlands. *Ann. Gewerbe Bauw.*, bd. lvii, pp. 48-55. [1905.]
6150. **Plot, R.** A Discourse of the Sepulchral Lamps of the Ancients. *Phil. Trans.*, vol. xv, p. 806. [1684.]
6151. **Plotnikov, A.,** see **Kononov, M. J.**
6151. **Plotz, W.** Origin of Petroleum, Coal, etc. 8vo, Whittier (Cal.), 1905.
6152. ——— Nature's Wonderful Laboratory. (Origin of Coal and Petroleum.) *Humanitarian Rev.*, vol. v, pp. 408-414. [1907.]
6153. ——— The Stratigraphy [sic, ubique] of the Whittier Oil Field. *Oil Industry*, vol. i, no. 2, pp. 7, 8. [1908.]
6154. ——— The Whittier Fields and Contiguous Territory, California. *Oil Industry*, Sept. 15, 1910.
6155. ——— Isotherm Hypothesis of the Origin of Petroleum, Coal, and other Carbonaceous Products. 8vo, Whittier, Cal., 1911.
6156. **Plumacher, E. H.** Petroleum Deposits in Venezuela. *Rep. Cons. U.S.*, no. 2, pp. 11-16. [1880.]
6157. ——— Petroleum Development in Venezuela. *Ibid.*, vol. xxi, pp. 556, 557. [1887.]
6158. ——— Asphalt and Petroleum Deposits in Venezuela. *Ibid.*, vol. xxvi, pp. 487-491. [1888.]
6159. **Plumb, H. S.** Colton's Map of the Oil District of Pennsylvania; comprising a part of the counties of Crawford, Venango and Warren. 1865.
6160. **Plummer, J.** Kerosene Shale in Australia. *Eng. Min. Journ.*, vol. lxxviii, pp. 66, 67. [1904.]
6161. **Plunkett, F. R.** Report for 1885 on the Trade of Nagasaki. *Dipl. Cons. Rep.*, ann. ser., no. 39. [1886.]
6162. **Plzak, F.,** and **V. Rosicky.** Ueber Fichtelit von Borkovic in Böhmen. *Zeitschr. Kryst. Min.*, bd. xlv, pp. 332-343. [1908.]
6163. **Pochon, —.** Note sur l'exploitation des pétroles de Pechelbronn (Alsace) et les Gisements de Sables Pétrolières de la Montagne du Credo (Ain). *Bull. Soc. Industr. Min.*, sér. 3, t. vii, pp. 111-127. [1893.]
6164. **Podgorski, Z.** Die rechtlichen Verhältnisse der Erdgase. *Naphta*, bd. xiii, pp. 281-283. [1905.]
6165. **Podimovski, S.** [Conference.] *Jurn. IX Sov. Inj. Viatk.*, pp. 81, 82. [1895.]
6165. **Poggendorff, J. C.,** see **Liebig, J. v.**
6166. **Poggi, J.** Sur une nouvelle source de pétrole [Amlano]. *Ann. Chim.*, t. xiv, p. 176. [1802.]
6167. **Pogson, —.** Reports for the years 1905, 1906, on the Trade and Shipping of Constantza. *Dipl. Cons. Rep.*, ann. ser., no. 3658, 3939. [1906, 1907.]
6168. **Pohl, J. J.** Chemisch-physicalische Notizen . . . . 7. Neue Methode zur Bestimmung von Schmelzpunkten. *Sitz. k. Ak. Wiss. Wien.*, bd. vi, p. 587. [1851.]
6169. **Pohlig, J.** Eiszeitliche Riesentiermumien-Funde in Starunia. *Petroleum Zeitschr.*, bd. vii, pp. 107, 108, pl. [1911.]
6170. **Poincaré, E. L.** Sur les effets de la respiration d'un air chargé de vapeurs de pétrole. *Compt. Rend.*, t. xcvi, pp. 353, 354. [1885.]
6171. ——— Traité d'Hygiène Industrielle. Paris, 1886.
6172. **Pois, A.** Ein neuer Erweiterungsmeissel. *Naphta*, bd. xv, pp. 171, 172, 183-187, 205-209. [1907.]
6173. ——— Ueber Rettungsgestänge. *Org. Ver. Bohrtechn.*, bd. xviii, pp. 2-5, 73-78. [1911.]
6174. **Pol, —.** [Objection to replacing Coal by Oil.] *Morsk. Sborn.*, 1865, no. 4, otd. iii.
6175. **Polack, G.** Benzin und seine Behandlung. *Compt. Rend. Congr. internat. Pétrole*, sess. 3, t. ii, pp. 599-620. [1910.]
6176. **Polak, J. E.** Persien, das Land und seine Bewohner. 1865.
6177. **Polakowsky, H.** [Petroleum in Peru.] *La Vos del Sur, Lima*, 1895.
6178. **Polevoi, P. I.** [Uchta Oilfield.] *Zap. Imp. Russk. Tekhn. Obsch.*, t. xlii, pp. 29-35. [1908.]
6179. ——— [Oilfields of Northeast Sakhalin.] *Bull. Com. géol. Russ.*, t. xxviii, pp. 415-462, pls. xiv, xv. [1909.]
6179. **Polevoi, P. I.,** see **Bogdanovitch, K. I.;** and **Tikhonovitch, N.**
6180. **Polonceau, —.** Des Bitumes et de leurs divers Emplois. *Rep. Gén. Archit.*, t. i, pp. 43-51, 91-97, 161-165. [1840.]
6181. **Pomel, A.** Explication de la deuxième édition de la Carte Géologique provisoire de l'Algérie au 1:800,000. 4to, Algiers, 1900.
6182. **Pommerol, F.** Âge des tufs bitumineux et basaltiques de la Limagne. *Bull. Soc. Géol. France*, sér. 3, t. ix, pp. 282-285. [1881.]
6183. **Poni, M.** [Importance and Utility of Pipe-Lines in the Petroleum Industry.] *Petrol. Roman.*, 1907, p. 421.
6184. **Poni, P.** Descrierea Mineralogică a României. *An. Acad. Roman.*, ser. 2, t. xxii, 1899.



6185. **Poni, P.** Études sur les minéraux de la Roumanie. *Ann. Sci. Univ. Jassy*, t. i, pp. 15-148. [1902.]
6186. ——— Recherches sur la composition chimique des pétroles roumains. *Ibid.*, pp. 205-231; t. ii, pp. 65-80; t. iv, pp. 192-202. [1902, 1903, 1907.]
6187. ——— Note sur l'action de l'acide azotique fumant sur le pentane secondaire. *Ibid.*, t. ii, pp. 53-58. [1903.]
6188. ——— Sur la présence du pseudo-cumol dans les pétroles roumains. *Ibid.*, t. iii, pp. 217, 218. [1906.]
6189. ——— Appareil pour faire les distillations fractionnées sous une pression constante. *Ibid.*, pp. 219-221. [1906.]
6190. **Poni, P.**, and **N. Costachescu.** Action de l'acide azotique de différentes concentrations sous pression, sur l'isopentane. *Ibid.*, t. ii, pp. 119-125. [1903.]
6191. ——— Sur les isohexanes contenus dans les pétroles roumains. *Ibid.*, t. iii, pp. 95-102. [1904.]
6192. **Ponson, J.** Du pétrole comme matière première du gaz d'éclairage. *Gén. Ind.*, t. xxxiv, pp. 281-287. [1867.]
6193. **Ponte, G. G.** Al Lago Naftia. *Atti Soc. Ital. Sci. Nat.*, vol. xxxiv, pp. 435-437. [1892.]
6194. **Pontio, M.** Recherche et dosage des matières bitumineuses dans la guttapercha. *Ann. Chim. anal.*, t. x, pp. 57, 58. [1905.]
- Ponzi, G.**, see **Carpi, P.**
6195. **Poole, H.** The Caloric Power of Fuels. Founded on Scheurer-Kestner's "Pouvoir Calorique des Combustibles." With the Addition of . . . Tables of Heats of Combustion of Fuels. 8vo, *New York*, 1898.
6196. **Poole, H. S.** The Coal-fields of New Brunswick, Canada. *Trans. Inst. Min. Eng.*, vol. xxiii, pp. 40-47. [1902.]
6197. ——— Report on the Pictou Coalfield, Nova Scotia. *Ann. Rep. Geol. Surv. Canada*, n.s., vol. xiv, M, pp. 38. 1905.
6198. **Popelitzko, A. A.** [The Petroleum Industry of Grozni in 1910.] *Grozni*, 1911.
6199. **Popescu, N. J.** Stosseffektverluste des Bohrzeuges. *Org. Ver. Bohrtechn.*, bd. xviii, pp. 100-103. [1911.]
6200. ——— Die Stosseffektverluste beim Spülbohren. *Ibid.*, pp. 137-140, 149, 150, 161-163. [1911.]
6201. **Popov, L.** Ueber die Sumpfgasführung. *Arch. ges. Physiol.*, bd. x, pp. 113-146. [1875.]
6202. **Popov, N.** [Oil-heating in Forges, Boilers, etc., in Moscow.] *Gorn. Journ.*, 1895, t. 3, pp. 1-30, 4 pls.
6203. **Popov, P. I.**, and **G. P. Kudelin.** [On the Use as Fuel of the Products of Baku Oil.] *Zap. Odessk. Otd. Imp. Russk. Tekhn. Obsch.*, Jan.-Feb., 1887, pp. 31-45.
6204. **Porges, P.** Emploi du Froid artificiel dans la Fabrication de la Paraffine. *Compt. Rend. Congr. Internat. Froid.*, sess. 1, t. i, pp. 451-454; t. iii, pp. 263-271. [1908.]
6205. **Porn, M.** [On the Advantages of Oil Fuel.] *Rev. Petrolului*, t. i, pp. 195-197. [1908.]
6206. ——— Concrete Oil Tanks. *Tiefbohrwesen*, 1908, h. 20.
6207. **Porro, B.** Sul petroli italiani; ricerche analitiche. *Gazz. Chim. Ital.*, t. xiii, pp. 77-85. [1883.]
6208. **Porro, C.** Un rapport sur la région de Salt-Creek (Wyoming). *Journ. Pét.*, t. x, pp. 222-224, 238-240, 253-256, 267-270. [1910.]
6209. **Porter, R. T.** Report on the Population and Resources of Alaska at the 11th Census, 1890. 8vo, *Washington*, 1893.
6210. **Porucic, T.** [Radio-activity of Petroleum.] *Ban. Kohass. Lap.*, köt. xli, pp. 163-165. [1908.]
6211. **Pošepny, F.** [On the Copper-bearing Permian of Bohemia.] *Zvea*, t. vii, p. 211; t. ix, pp. 32-49. [1859, 1861.]
6212. ——— Das Vorkommen und die Gewinnung von Petroleum in Sanoker und Samborer Kreise Galiziens. *Jahrb. k.-k. geol. Reichs.*, bd. xv, pp. 361-368. [1865.]
6213. **Pošepny, F.** Studien aus dem Salinengebiet Siebenbürgens. *Jahrb. k.-k. geol. Reichs.*, bd. xvii, pp. 475-516, pl. x-xii; bd. xxi, pp. 123-183, pl. v. [1867, 1871.]
6214. ——— Schlagwetter-Explosion im Hallstädter Salzberge von 1664. *Oesterr. Zeitschr. Berg.-Hüt.*, bd. xxxiii, pp. 606, 607. [1885.]
6215. **Posewitz, T.** Das Petroleumvorkommen in Borneo. *Das Ausland*, bd. ix, pp. 191, 192. [1887.]
6216. ——— Bericht über die geologische Aufnahme im Jahre 1887 [Körösmező]. *Jahresb. k.-ung. geol. Anst.*, 1887, pp. 114-124. [1889.]
6217. ——— Borneo; its Geology and Mineral Resources. 8vo, *London*, 1892.
6218. ——— Umgebung von Körösmező und Bogdao. *Erl. geol. Spezialkarte Ung.* [1893.]
6219. ——— Umgebung von Marmaroszeitget. *Ibid.* [1894.]
6220. ——— Das Gebiet zwischen dem unteren Läufe der Flüsse Taracz und Talabor. *Jahresb. k. ung. geol. Anst.*, 1895, pp. 30-40. [1898.]
6221. ——— Das Petroleumgebiet von Körösmező (Marmaros). *Mitth. Jahrb. k.-ung. geol. Anst.*, bd. xi, pp. 299-308, pl. xi [map. 1:75,000]. [1897.]
6222. ——— Petroleum und Asphalt in Ungarn. *Mitth. Jahrb. k.-ung. geol. Anst.*, bd. xv, pp. 235-465, pl. xi. [1907.]
6223. **Possanner, B. v.** Chemische Technologie der landwirtschaftlichen Gewerbe, nebst eine kurzen Abhandlung über Mineralöle. *Vienna*. Ed. iii, 1893.
6224. **Post, H. v.** Kalkgranit und bergbeck. *Geol. Fören. Stockh. Förh.*, bd viii pp. 453, 454. [1886.]
6225. **Post, J.** Chemisch-technische Analysen. Handbuch der analytischen Untersuchung zur Beaufichtigung des chemischen Grossbetriebes und zum Unterrichte. 8vo, *Brunswick*, 1881.
6226. **Potilitzin, A.** [The Composition of the Water, accompanying Petroleum, and thrown up by Mud Volcanos.] *Jurn. Russk. Fiz. Khim. Obsch.*, t. xiv, otd. i, pp. 300-310; t. xv, otd. i, pp. 179-184, 388-401. [1882, 1883.]
6227. ——— [Excursion to the Crimea and Caucasus. *Izv. Varsavsk. Univ.*, 1883, no. 1, pp. 1-5.
6228. ——— [Condition of the Oil Industry in the Kuban.] *Gorn. Journ.*, 1885, t. i, p. 129.
6229. ——— [Composition and Mode of Formation of the Dolomites of the Il Valley, Kuban.] *Ibid.*, t. 4, pp. 98-123, pl.
6230. ——— [The Crimean Oilfield.] *Trudi Bak. Otd. Imp. Russk. Tekhn. Obsch.*, g. x, v. 4, pp. 40-42. [1895.]
6231. **Potilitzin, A. L.**, and **A. Bernstein.** [Crimean Oilfields.] *Jurn. Russk. Fiz. Khim. Obsch.*, t. xxvii, pp. 276-282. [1895.]
6232. **Potonie, H.** Eine rezent organogene Schlamm-Bildung des Cannekkohlen Typus. *Jahrb. k. preuss. geol. Landesanst.*, bd. xxiv, pp. 404-409. [1903.]
6233. ——— Zur Frage nach den Ur-materialien der Petrolea. *Abh.*, bd. xxv, pp. 342-368. [1904.]
6234. ——— Ueber Faulschlamm- (Sapropel-) Gesteine. *Sitz. nat. Ges. Freunde Berlin*, 1904, pp. 243-245.
6235. ——— Ueber die Genesis des Petroleums. *Ibid.*, 1905, pp. 1, 2.
6236. ——— Die Entstehung des Petroleums. *Petroleum Zeitschr.*, bd. i, pp. 73-76. [1905.]
6237. ——— Ueber rezente Pyropissit. *Zeitschr. deutsch. geol. Ges.*, bd. lvii, Prot., pp. 255-259 [1906.]
6238. ——— Klassifikation und Terminologie der rezenten brennbaren Biolithe und ihrer Lagerstätten. *Abh. k. preuss. geol. Landesanst.*, n.s., no. 49. Pp. vi, 94. [1906.]
6239. ——— [Formation of Coal and Petroleum.] *Gorn. Journ.*, 1906, t. 4, pp. 223-234.
6240. ——— Die Entstehung der Steinkohle und verwandter Bildungen einschliesslich des Petroleums. *Berlin*, 1907.
6241. ——— Die rezenten Kaustobiolithe und ihre Lagerstätten. *Abh. k. preuss. geol. Landesanst.*, n.s., no. 55. Pp. xv, 261. [1908.]

6242. **Potonie, H.** Eine Klassifikation der Kaustobrolithe. *Sitz. k. preuss. Ak. Wiss.*, 1908, pp. 154-165.
6243. ——— Die Entstehung der Steinkohle und der Kaustobrolithe überhaupt. *Berlin*, 1911.
6244. **Pottinger, H.** Travels in Beloochistan and Sinde, with a Geographical and Historical Account. 4to, London, 1816.
6245. **Potts, H. E.**, see **Donnan, F. G.**
6246. **Pouchet, A. G.** Action de l'acide nitrique sur la paraffine; produits divers qui en résultent. *Compt. Rend.*, t. lxxix, pp. 320-324. [1874.]
6246. **Pouqueville, F. C. H. L.** Voyage en Morée, à Constantinople, en Albanie, et dans plusieurs autres parties de l'Empire Othoman, pendant les Années 1798-1801. 3 Tt. 8vo, Paris, 1805.
6247. **Powell, A. E.**, see **Bell, C.**
6247. **Powell, W.** Report for the years 1887-1896, on the Trade of Settin. *Dipl. Cons. Rep.*, ann. ser., nos. 449, 603, 776, 963, 1115, 1297, 1623, 1808, 1896, 2010. [1889-97.]
6248. **Powers, R. M.** The Use of Crude Petroleum for Firing Benches [Pacific Coast Gas Assoc.]. *Amer. Gas Light Journ.*, vol. lxxiii, pp. 207, 208. [1900.]
6249. **Prager, H.** Riqueza Mineral do Estado de Bahia. *Rep. Inst. Geogr. Hist. Bahia*, t. iv, pp. 233-244. 419-431; t. v, pp. 81-106; t. vi, pp. 57-99. [1897-1899.]
6250. **Pratt, S. P.** Geological Position of the Bitumen used in Asphalt Pavements. *Quart. Journ. Geol. Soc.*, vol. ii, pp. 80, 81. [1846.]
6251. **Pratt, W. E.**, see **Adams, G. I.**
6251. **Precht, H.** Die Bestandtheile der brennbaren Gase in den Kalisalzbergwerken bei Stassfurt. *Ber. deutsch. chem. Ges.*, bd. xii, pp. 557-561. [1879.]
6252. ——— Ueber das Vorkommen von Erdöl in dem Salzbirgwerk Desdemona bei Alfeld am Leine. *Zeitschr. angew. Chem.*, bd. xx, p. 223. [1907.]
6253. **Predit, A. T.** [Decoloration and Deodorisation of Petroleum.] *Trudi Bak. Old. Imp. Russk. Tekhn. Obsch.*, g. xxii, p. 49. [1907.]
6254. ——— Eine Untersuchung des Erdöls. *Compt. Rend. Congr. internat. Pétrole*, sess. 3, t. ii, pp. 553-560. [1910.]
6255. **Predit, A. T.**, and **V. F. Herr.** [Examination of the Surakhani "White" Oil.] *Trudi Bak. Old. Imp. Russk. Tekhn. Obsch.*, 1906, no. 8, pp. 11-27.
6256. **Predit, A. T.**, and — **Yagubov.** [Solubility of Unsaturated Petroleum Hydrocarbons in Acetone.] *Ibid.*, g. xxi, v. 7. [1906.]
6257. ——— [The Sandsberg Process of Refining Lubricants.] *Ibid.*, Oct. 1906.
6258. **Press, A.** [Spontaneous Combustion of Petroleum and its Derivatives.] *Gorn. Journ.*, 1894, t. 4, pp. 308-311.
6259. **Preston, E. B.** Monterey County. 11th Ann. Rep. State Mineral. California, pp. 259-262. [1893.]
6260. ——— San Benito County. *Ibid.*, pp. 370-373. [1893.]
6261. **Prestwich, J.** Memoir on the Geology of Coalbrookdale. *Trans. Geol. Soc.*, ser. 2, vol. v, pp. 413-496. [1836.]
6262. **Pretiner.** ——— Kann die Analyse zur Zeit Aufschluss über die Brauchbarkeit von Asphalten geben? *Asphalt-Teerind.-Zeit.*, bd. x, pp. 79, 80, 100-102. [1910.]
6263. **Priemski, N. N.** [Malkop Oilfield.] *Gorn. Journ.*, 1909, t. 4, pp. 217-222.
6264. **Prieto, A.** Historia del Estado de Tamaulipas.
6265. **Prilejaev, B.** Petroleum Wealth of Russia. *Journ. Soc. Arts*, vol. xxxix, pp. 275-277. [1891.]
6266. **Pring, J. N.** The Direct Union of Carbon and Hydrogen at High Temperatures. *Journ. Chem. Soc.*, vol. xvii, pp. 498-511. [1910.]
6267. **Pring, J. N.**, and **D. M. Fairlie.** The Synthesis of Hydrocarbons at High Temperatures. *Ibid.*, vol. xcix, pp. 1796-1811. [1911.]
6268. ——— The Methane Equilibrium *Ibid.*, vol. ci, pp. 91-103. [1912.]
6269. **Pring, J. N.**, and **R. S. Hutton.** The Direct Union of Carbon and Hydrogen at High Temperatures. *Journ. Chem. Soc.*, vol. lxxxix, pp. 1591-1601. [1906.]
6270. **Proehazka, V. J.** [Petroleum in Eastern Moravia.] *Narodni Listy (Prague)*, 1901, no. 126.
6271. **Prörsdorf, C.** Physikalisch-photometrische Untersuchungen der in Deutschland gegenwärtig hauptsächlich gehandelten gewöhnlichen Leucht-Petroleumarten auf den gegenwärtig in Deutschland gebräuchlichsten Petroleum-Brennern. 4to, Altenburg, 1905.
6272. ——— Beurteilung der in Deutschland verwendeten Leucht-Petroleumarten. *Naphtha*, xiii, pp. 24-27, 34-37, 53-55. [1905.]
6273. ——— Praktische Brennversuche und photometrische Prüfung von Leucht-Petroleum. *Altenburg*, 1907.
6274. ——— Bericht des deutschen Komitees für dem III-ten Internationalen Petroleumkongress. *Compt. Rend. Congr. internat. Pétrole*, sess. 3, t. ii, pp. 815-819. [1910.]
6275. **Propin.** — [Asphalt-felt.] *Inj. Journ.*, 1877, p. 195.
6276. **Prosser, C. S.** Section of the Lower Devonian and Upper Silurian Strata in Central New York, as shown by a deep well at Morrisville. *Proc. Amer. Assoc.*, vol. xxxvi, pp. 208, 209. [1888.]
6277. ——— The Thickness of the Devonian and Silurian Rocks of West Central New York. *Amer. Geol.*, vol. vi, pp. 199-210. [1890.]
6278. ——— The Thickness of the Devonian and Silurian Rocks of Central New York. *Bull. Geol. Soc. Amer.*, vol. iv, pp. 91-118. [1893.]
6279. ——— Gas-Well Sections in the Upper Mohawk Valley and Central New York. *Amer. Geol.*, vol. xxv, pp. 131-162. [1900.]
6280. ——— The Sunbury Shale of Ohio. *Journ. Geol.*, vol. x, pp. 262-312. [1902.]
6281. **Prosser, W. T.** Opening Alaska's Oilfields. *Eng. Min. Journ.*, vol. xci, p. 1098. [1911.]
6282. ——— Katalla, Alaska, Oil Field. *Mines and Minerals*, vol. xxxi, p. 731. [1911.]
6283. **Prosenko, Yu.** [Remarks on Railway Business and Petroleum in the Caucasus.] 1879.
6284. **Prune.** — [Hydrocarbons from American Petroleum.] *Gorn. Journ.*, 1879, t. 1, p. 407.
6285. **Prunier, L.** Recherches sur la nature des Carbores incomplets qui prennent naissance dans le traitement pyrogène des pétroles d'Amérique. *Ann. Chim. Phys.*, sér. 5, t. xvii, pp. 1-62. [1879.]
6286. **Prunier, L.**, and **R. David.** Sur la nature de certains produits cristallisés, obtenus accessoirement dans le traitement industriel des pétroles de Pennsylvanie. *Compt. Rend.*, t. lxxxvii, pp. 991-993. [1878.]
6287. **Prunier, Léon**, and **E. Varenne.** Sur les produits contenus dans les coques de pétrole. *Bull. Soc. Chim. Paris*, sér. 2, t. xxxiii, pp. 567-572. [1880.]
6288. **Pruzman, P. W.** Petroleum in California. *Petrol. Rev.*, vol. ix, pp. 331-334, 351-354, 395-397, 424, 425, 435, 436. [1903.]
6289. ——— Oil Wells in Kern County. Pp. 20-22 of Register of Mines and Minerals, Kern County. With 4 maps. *Register Calif. State Min. Bureau*, 1904.
6290. ——— Production and Use of Petroleum in California. *Bull. Calif. State Mining Bureau*, no. 82. [1904.]
6291. ——— [Texas and California Crude Oils.] *Journ. Electr. Power and Gas*, 1904.
6292. ——— Chemistry of California Petroleum. *Amer. Geol.*, vol. xxxv, pp. 240-243. [1905.]
6293. ——— Notes regarding Gas Tars [Pacific Coast Gas Assoc.]. *Amer. Gas Light Journ.*, vol. lxxxiii, pp. 529-534. [1905.]
6294. ——— Coalinga Oil Field. *Mining Science*, vol. xi, pp. 464-466 [1910.]
6295. ——— The Origin of Petroleum. *California Derick*, vol. ii, nos. 11, 12; vol. iii, nos. 1, 6. [1910.]
6296. ——— The Manufacture of Petroleum Lubricating Oils. *Petrol. Rev.*, vol. xxiii, pp. 343, 344. [1910.]

6297. **Przibilla, E.** Note sur l'Appareil de Sondage automatique à manivelle. *Rev. Univ. Mines*, sér. 3, t. iv, pp. 117-125. [1888.]
6298. — Die Hypothesen der Erdölbildung. *Naphta*, bd. ix, pp. 423-426. [1901.]
6299. **Puchot, E.** Recherches sur le Butylène et sur ses dérivés. *Ann. Chim. Phys.*, sér. 5, t. xxviii, pp. 508-569. [1883.]
6300. **Puiggari, M.** see Aguirre, E.
6301. **Purnell, S.** On Ionite, a new Mineral [Hydrocarbon, from Ione, California]. *Min. Sc. Press*, March 24, 1877.
6302. **Pury, G. de.** Sur un Filon croiseur d'Asphalt. *Bull. Soc. Sci. Nat. Neuchâtel*, t. i, pp. 190-195. [1845.]
6303. **Puscarin, V.** see Mrazec, L.
6304. **Pusch, G.** Geognostischen Beschreibung von Polen, so wie der übrigen Nordkarpathen Länder. 2 Bde. 8vo, Stuttgart and Tübingen, 1833, 1836.
6305. **Puschin, —.** [The Caspian Sea.] 1877.
6306. **Putnam, X. W.** Early Waste of Petroleum. *Mines and Minerals*, vol. xxx, pp. 491, 492. [1910.]
6307. **Putokhin, M.** Isoktonaphthene and its Products. *Journ. Russk. Fiz.-Khim. Obsch.*, t. xvi, otd. 1, p. 295. [1884.]
6308. **Puvic, C.** Notice sur les Mines de Bitume et sur la Fabrique de Cement Asphaltique de Pyrimont (Ain). *Ann. Mines*, sér. 3, t. vi, pp. 179-187. [1834.]
6309. **Pyhäälä, E.** Die gegenwärtige fabrikmässige Verabreichung der Laugen abfälle der Petroleum raffinieren in Baku. *Petroleum Zeitschr.*, bd. iii, pp. 571-574. 1908.
6310. — Verbrennungsvorgänge bei der Rohölheizung. *Ibid.*, bd. iv, pp. 1229-1231. [1909.]
6311. — Ist das lichte Erdöl von Ssurachany bei Baku ein Filtrationsprodukt? *Ibid.*, bd. v, pp. 1525-1533. [1910.]
6312. — Die nadelförmigen Paraffin-Krystalle und ihre Bedeutung für das Schottländische Schwitzverfahren bei der Paraffinfabrikation. *Compt. Rend. Congr. internat. Chim. appl.*, sess. 7, sect. iv, pp. 32-38. [1910.]
6313. — Die Gesetzmässigkeit der Viskosität einiger kaukasischer Erdöle und Erdölderivate bei korrespondierenden Temperaturen und in beliebigen Mischungsverhältnissen. *Petroleum Zeitschr.*, bd. vii, pp. 207-229. [1911.]
6314. — Die Bedeutung der Kolloidchemie für die Naphthalene. *Zeitschr. Chem. Ind. Koll.*, bd. ix, pp. 209-216. [1911.]
- Quayle, W. O.**, see Mabery, C. F.
6315. **Quekett, J.** On the Minute Structure of a Peculiar Combustible Mineral from the Coal Measures of Torbane Hill near Bathgate, Linlithgowshire, known in Commerce as Boghead Cannel Coal. *Trans. R. Microsc. Soc.*, vol. ii, pp. 34-65. [1854.]
6316. **Quenstedt, F. A.** Ueber Lepidotus im Lias e Württembergs. 4to, Tübingen, 1847.
6317. — Handbuch der Mineralogie. 8vo, Tübingen. 1854.
6318. — Sonst und Jetzt. 8vo, Tübingen, 1856.
6319. — Der Jura. 8vo, Tübingen, 1858.
6320. — Klar und Wahr. 8vo, Tübingen, 1872.
- Quiroga, A.** see Nystromer, C.
6321. **R.** — D. Ueber den Zusammenhang zwischen Leuchtkraft, Siedetemperaturen und Entflammungspunkt des Petroleums. *Zeitschr. Paraff. Industr.*, 1885, pp. 47, 48.
6322. **R.** — H. Die Verwendung künstlicher Kälte in Petroleumraffinerien. *Petroleum Zeitschr.*, bd. ii, p. 103. [1906.]
6323. **R.** — I. Asphaltgewinnung aus Kalifornischem Erdöl. *Asphalt-Teerind.-Zeit.*, bd. xi, p. 26. [1911.]
6324. — Die Herstellung und Unterhaltung von Schotterstrassen in den Vereinigten Staaten Nordamerikas mit Hilfe von bituminösen Stoffen. *Ibid.*, pp. 400, 420. [1911.]
6325. **R.** — J. Sources de pétrole en Italie. *Journ. Éclair. Gaz.*, ann. xvii, pp. 358, 359. [1869.]
6326. **R.** — R. Schürf- und Aufschlussarbeiten betriebs Petroleumgewinnung in Ungarn. *Allg. österr. Chem. Techn.-Zeit.*, bd. ii, no. 15. [1884.]
6327. **Rabino, H. L.** Report on the Trade of Kermanshah and District for the year 1903-04. *Dipl. Cons. Rep.*, ann. ser., no. 3189. [1904.]
6328. **Rabinovitch, A. M.** [Commercial Benzines.] *Journ. Russk. Fiz.-Khim. Obsch.*, t. xxxiv, otd. 1, pp. 200, 201. [1902.]
6329. **Raczkievicz, M.** Petroleum-Vorkommen in Galizien. *Oesterr. Zeitschr. Berg.-Hütt.*, bd. xxvii, pp. 15-18, 32-35. [1879.]
6330. **Radde, G.** Vier Vortragen über den Kaukasus. *Mith. geogr. Anst.*, erg.-bd. viii, no. 36, pp. 74, 2 pls. [1874.]
6331. **Radziowski, B. v.** [Origin of Petroleum.] *Sitz. badnise. Comm. Krak. Aerzt-Ver.*, 1877, p. 35.
6332. — [On the Origin of Petroleum.] *Czasop. Towarz. Aptek. Lemberg.* [1878.]
6333. — [Petroleum and Ozokerite of Galicia.] *Wszecznosc*, 1885.
6334. **Raffles, T. S.** The History of Java. 2 vols. 8vo, London, 1817.
6335. **Ragozin, A. V.** Ueber ein neues Rohöl aus Turkestan. *Chem. Rev. Fett-Harz-Ind.*, bd. xii, pp. 182-185. [1905.]
6336. **Ragozin, E.** [On the Question of the more Profitable Utilisation of Petroleum.] *Gorn. Journ.*, 1908, t. 3, pp. 238-255
6337. **Ragozin, V. I.** [Description of a Collection of Products of Distilled Naphtha.] *Zap. Imp. Russk. Tekhn. Obsch.*, g. xxii, v. 2, pp. 89-107. [1888.]
6338. — Erzeugung von Brennlösen aus Naphtarückständen und schweren Naphtasorten. *Chem.-Zeit.*, bd. xv, p. 228. [1891.]
6339. — Die rationelle Destillation und Verarbeitung von Roherdölen verschiedener Provenienz. *Chem. Rev. Fett-Harz-Ind.*, bd. vi, pp. 128-134, 147-151, 161-166. [1899.]
6340. — Ueber Schmierölfabrikation in Baku. *Ibid.*, bd. ix, pp. 128-130. [1902.]
6341. — Sumatra, Russian and American Kerosenes. *Petroleum*, vol. iii, pp. 40-44, 90-92. [1902.]
6342. — A Comparative Study of Kerosenes from Borneo and Java. *Ibid.*, pp. 335, 336. [1902.]
6343. — [The Petroleum Industry in the Dutch Indies and Japan.] *Nepht. Dielo*, 1902.
6344. **Ragozin, V. I., V. Markovnikov, and V. N. Ogloblin.** [Petroleum and the Petroleum Industry.] 8vo, St. Petersburg, 1884.
6345. **Rahn, O.** Ein paraffinsetzender Schimmelpilz. *Centrabl. Bakt. Parasitenk.*, bd. xvi, pp. 382-384. [1906.]
6346. **Raicevich, —.** Osservazioni storiche intorno la Valachia e Moldavia. *Naples*, 1789.
6347. **Raikes, F. D.** Letter reporting an Eruption from one of the Mud Volcanoes of Cheduba Island, Arakan, Akya. *Rec. Geol. Surv. India*, vol. xvi, pp. 204, 205. [1883.]
6348. **Raikov, P. N.** Ueber die Entflammungstemperatur organischer Verbindungen. *Chem.-Zeit.*, bd. xxiii, pp. 145-147. [1899.]
6349. **Raimondi, A.** El Peru. T. iv. Estudios mineralógicas y geológicas. 1a Serie. 4to, Lima, 1902.
6350. **Rakuzin, M. A.** [Valuation of Residual Acid and Lye in Petroleum Refining.] *Nepht. Dielo*, 1903, pp. 643-650.
6351. — [Optical Properties of Petroleum and its Distillation-Products.] *Journ. Russk. Fiz.-Khim. Obsch.*, t. xxxvi, otd. 1, pp. 554-559; t. xxxvii, otd. 1, pp. 85-91. [1904, 1905.]
6352. — [Synthesis of Petroleum and its Origin.] *Ibid.*, t. xxxvii, otd. 1, pp. 79-83. [1905.]
6353. — [Properties of Pennsylvania Oil under Polarized Light.] *Ibid.*, pp. 149, 150. [1905.]
6354. — Indirect Determination of Water in Oils, Fats and Waxes. *Ibid.*, t. xxxviii, otd. 1, pp. 676, 677. [1906.]

- 6353 **Rakuzin, M. A.** Optical Phenomenon of Tyndall and its bearing on the Microscopy and Geology of Petroleum. *Jurn. Russk. Fiz. Khim. Obsch.*, t. xxxviii, otd. 1, pp. 790-798. [1906.]
6354. — Optical Properties of Galician Petroleum. *Ibid.*, p. 1087. [1906.]
6355. — [Presence of Cholesterin in Waxes and Petroleum, and consequent genetic relations between them.] *Ibid.*, pp. 1129-1135. [1906.]
6356. — Optical Properties of Rumanian Petroleum. *Ibid.*, p. 1293. [1906.]
6357. — Die Untersuchung des Mineralöle und Fette. *Chem.-Zeit.*, bd. xxx, p. 46. [1906.]
6358. — Ueber das optische Verhalten und einige andere Eigenschaften der wichtigsten Fette des Tierreichs. *Ibid.*, pp. 1247-1249. [1906.]
6359. — Die Untersuchung der Erdöls und seiner Produkte. Eine Anleitung zur Expertise des Erdöls. 8vo, Brunswick, 1906.
6360. — Die Erdölindustrie und die exakte Erdölforschung. *Petroleum Zeitschr.*, bd. i, pp. 504-506. [1906.]
6361. — Die Verdienste Biots um die Chemie des Erdöls. *Ibid.*, bd. ii, pp. 189, 190. [1906.]
6362. — [Optical Examination of Petroleum from Holy Island, Bereket, and Bibi-Eibat.] *Bull. Com. géol. Russ.*, t. xxv, pp. 463-494. [1906]; t. xxvi, pp. 141-313. [1907.]
6363. — Ueber die künstlichen Benzine. *Chem.-Zeit.*, bd. xxxi, pp. 3-6. [1907.]
6364. — Ein Wort zu meinen Erdölarbeiten. *Ibid.*, p. 477. [1907.]
6365. — [On some Optically Inactive Petroleum.] *Jurn. Russk. Fiz. Khim. Obsch.*, t. xxxix, otd. 1, p. 634. [1907.]
6366. — [Cholesterine Reaction of Petroleum.] *Ibid.*, p. 634. [1907.]
6367. — [Optical Investigation of the Bibi-Eibat Oil.] *Ibid.*, pp. 802-814, 1343-1353; t. xli, pp. 483-500. [1907, 1909.]
6368. — [Optical Properties of Petroleum of the Uchta District.] *Ibid.*, t. xxxix, pp. 1175, 1176. [1907.]
6369. — [Optical Properties of Tegernsee Petroleum.] *Ibid.*, p. 1176. [1907.]
6370. — Die Cholesterinfrage in der Erdölchemie. *Petroleum Zeitschr.*, bd. ii, pp. 797-800. [1907.]
6371. — Einige Betrachtungen über optisch halbdurchsichtige Erdöle. *Ibid.*, bd. iii, pp. 98-101. [1907.]
6372. — Optische Untersuchung des Erdöles aus Elsass (Pechelbronn.) *Ibid.*, pp. 948-951. [1908.]
6373. — Ueber das optische Verhalten des Erdöls aus der Umgebung von Sjesnowodsk (Gouv. Samara). *Ibid.*, pp. 1203-1205. [1908.]
6374. — [Physiological Properties of Petroleum.] *Revista Petrolului*, t. i, pp. 257-259. [1908.]
6375. — [Optical Investigation of Petroleum from Raman, Surakhani, and Balakhani (Baku).] *Bull. Com. géol. Russ.*, t. xxvii, pp. 407-458. [1908.]
6376. — [Optical Investigation of Raman Petroleum, Baku.] *Jurn. Russk. Fiz. Khim. Obsch.*, t. xl, otd. 1, pp. 260-267. [1908.]
6377. — [Influence of Centrifugal Force on the Optical and other Properties of Petroleum.] *Ibid.*, pp. 1583-1588. [1908.]
6378. — [Optical Examination of Sakhalin Petroleum.] *Ibid.*, pp. 1735-1746. [1908.]
6379. — [Optical and other Properties of Groznil Oil.] *Ibid.*, t. xli, p. 109. [1909.]
6380. — [Optical Properties of Tcheleken Ozokerite.] *Ibid.*, pp. 109, 110. [1909.]
6381. — Ueber die Notwendigkeit systematischer optisch-chemischer Erdölstudien. *Ber. deutsch. chem. Ges.*, bd. xli, pp. 4675-4678. [1909.]
6382. — Ueber den Paraffingehalt der Erdöle als Kriterium zur Beurteilung des relativen geologischen Alters derselben. *Ibid.*, bd. xliii, pp. 1211-1215. [1909.]
6383. **Rakuzin, M. A.** Ueber das optische Drehungsvermögen der natürlichen Erdöle im polarimetrisch leeren Zustande. *Ber. deutsch. chem. Ges.*, bd. xliii, pp. 1640-1647. [1909.]
6384. — Der gegenwärtige Zustand der Cholesterintheorie in der Erdölchemie. *Petroleum Zeitschr.*, bd. iv, p. 385. [1909.]
6385. — Jahresbericht über die Fortschritte auf dem Gebiete der Naphthologie in Russland im Jahre 1908. *Ibid.*, pp. 980-985. [1909.]
6386. — Ueber die Notwendigkeit systematischer chemisch-geologischer Erdölstudien. *Ibid.*, bd. v, pp. 81-86. [1909.]
6387. — Die Theorie der Färbung der natürlichen Erdöle und deren notwendige Konsequenzen. *Ibid.*, pp. 309-315. [1909.]
6388. — Optische Untersuchung des Erdöles aus Maikop. *Ibid.*, pp. 1319, 1320. [1910.]
6389. — Die Polarimetrie der Erdöle. *Berlin and Vienna*, 1910.
6390. — Versuch einer physiko-chemischen Theorie der Erdölgeologie. *Compt. Rend. Congr. internat. Pétróle*, sess. 3, t. II, pp. 57-60. [1910.]
6391. — Vergleichende physiko-chemische Betrachtungen über kaukasische und rumänische Erdöle. *Ibid.*, pp. 761-770. [1910.]
6392. — Ueber die Nothwendigkeit der Gründung einer Schule der Erdölindustrie. *Ibid.*, pp. 885-888. [1910.]
6393. — [Optical Investigation of Petroleum from S. Bolivia.] *Jurn. Russk. Fiz. Khim. Obsch.*, t. xliiii, pp. 791, 792. [1911.]
6394. — [Optical Investigation of Argentine Petroleum.] *Ibid.*, pp. 792, 793. [1911.]
6395. — Bemerkung zur Abhandlung von Hans Friedenthal; ueber quantitative chemische analyse von Gemengen mit verwendung der Differenzen un spezifischen Gewichts. *Ber. deutsch. chem. Ges.*, bd. xliiv, p. 1676. [1911.]
6396. — Bericht über die Fortschritte der Naphthologie in Russland im Jahre 1910. *Petroleum Zeitschr.*, bd. vi, pp. 881-887. [1911.]
6397. — Ueber das optische Verhalten und einige andere Eigenschaften der japanischen Erdöle. *Ibid.*, pp. 1048-1053. [1911.]
6398. — Ueber die Verdienste Moissans um die Chemie des Erdöles. *Ibid.*, bd. vii, pp. 63, 64. [1911.]
6399. — Ueber die vergleichende Zusammensetzung von korrespondierenden Erdölen. *Ibid.*, pp. 288, 289. [1911.]
6400. **Rakuzin, M. A.**, and **E. Laszlo.** Ueber das optische Verhalten des Erdöles aus dem Komitat Máramaros in Ungarn. *Ibid.*, bd. iii, pp. 1125-1128. [1908.]
6401. — Optische Untersuchung galizische Erdöle. *Ibid.*, bd. v, pp. 373-378. [1910.]
6402. **Ralph, T. S.** Report on the Resinous Shales of the Mersey River, Tasmania. *Po, Hobart*, 1861.
6403. — Observations on the Microscopical Characters presented by a Mineral [Dysodite] from Tasmania. *Trans. R. Soc. Vict.*, vol. vi, p. 7. [1865.]
6404. **Ramakers, L.** The Automobile Boat, *Hilda. Marine Engineering*, vol. x, pp. 172-174. [1905.]
6405. — An Interesting Race and Racing Launch [Nina]. *Ibid.*, pp. 419, 420. [1905.]
6406. **Ramazzini, B.** De fontium Mutinensium admirandâ scaturigine. *Modena*, 1691.
6407. **Ramboson, J.** Grand avenir auquel est appelée l'huile de pétrole, soit par sa transformation en gaz pour l'éclairage, soit par son emploi pour le chauffage des machines à vapeur, etc. *Ann. Gén. Civ.* [sér. 1], t. ii, pp. 402-404. [1863.]
6408. **Ramdohr, L.** Misch- und Filterapparat zum Entfärben von Paraffin mittels pulverisirter Knochenkohle. *Polyt. Journ.*, bd. ccxvi, pp. 244-250, pl. iii. [1875.]
6409. — Verfahren der Anwendung von Wasserdämpfen bei der Destillation von Flüssigkeiten. *Ibid.*, vol. ccxxii, pp. 67-75. [1879.]

6410. **Rammelsberg, C. F.** Handwörterbuch des chemischen Theils der Mineralogie. 3 Bde. 8vo, Berlin, 1841-1853.
6411. **Ramsauer, P.** Petroleum. 8vo, Oldenburg, 1886.
6412. **Ramsden, J. C.** Improvement in Hydrocarbon Furnaces. *Sci. Amer. Suppl.*, vol. i, p. 125. [1876.]
6413. ——— Verfahren und Vorrichtung zum Härten und Anlassen des Stahlrohres. *Polyt. Journ.*, bd. cccxxxviii, pp. 290-292. [1880.]
6414. **Ramsden, W.** Separation of Solids in the Surface-layers of Solutions and Suspensions (Observations on Surface-membranes, Bubbles, Emulsions and Mechanical Coagulation). *Proc. Roy. Soc.*, vol. lxxii, pp. 156-164. [1903.]
6415. **Ramsden, W. F.** Report for 1894 on the Trade of St. Jago de Cuba. *Dipl. Cons. Rep.*, ann. ser., no. 1643. [1895.]
6416. **Rand, B. H.** Note on the Protection of Oil Tanks from Lightning. *Proc. Amer. Phil. Soc.*, vol. xix, p. 216. [1880.]
6417. **Rand, T. D.** The Occurrence of Petroleum in Canada. *Journ. Franklin Inst.*, ser. 3, vol. i, pp. 59-66. [1865.]
6418. **Randall, F. A.** see **Carl, J. F.**
6418. **Randall, John.** The Burning Well at Broseley. *Geol. Mag.*, vol. ii, pp. 232, 233. [1865.]
6419. ——— Petroleum in Shropshire. *Coll. Guard.*, vol. xi, p. 408. [1866.]
6420. **Rankine, W. J. M.** On the Economy of Fuel, comprising Mineral Oils. *Journ. Roy. United Serv. Inst.*, vol. xi, pp. 218-240. [1867.]
6421. ——— On the Estimation of the Evaporative Power of Fuel. *Proc. Phil. Soc. Glasgow*, vol. vi, pp. 123-126. [1868.]
6422. **Ransome, L. H.** Cask-making Machinery. *Proc. Inst. Civ. Eng.*, vol. cxv, pp. 193-215. [1893.]
6423. **Raoult, F. M.** Composition du Gaz de la fontaine ardente de Saint Barthélemy (Isère). *Compt. Rend.*, t. lxx, pp. 1095, 1096. [1870.]
6424. **Rapisardi, B.** Sullo asfalto di Bocca d'Urso presso Leonforte. *Atti Acc. Gioen. Sci. Nat.*, vol. x, pp. 223-234. [1835.]
6425. **Rasinski, F.** Ueber fractionirte Destillation im Wasserdampfströme als eine neue Methode zur Untersuchung der Gemengtheile des Erdöls. *Journ. prakt. Chem.*, bd. cxxxvii, pp. 39-42. [1884.]
6426. **Rassasp, J. C. T.** Manjak as worked at the Vistabella Mine, Trinidad. *Trans. Inst. Min. Eng.*, vol. xxxvi, pp. 119-124, pl. iii. [1909.]
6427. **Ratard, —.** Gisements pétroliers à Java. *Corps Gras Ind.*, t. xxiv, pp. 69, 70. [1897.]
6428. **Rateau, A.** Note sur l'Ozokerite, ses Gisements, son Exploitation à Boryslaw, et son traitement industriel. *Ann. Mines*, sér. 8, t. xi, pp. 147-170. [1887.]
6429. **Rath, G. vom.** Pennsylvanien. *Heidelberg*, 1888.
6430. **Rathbone, E. P.** Oil Prospects in Cape Colony. *Petrol. Rev.*, vol. xiii, p. 382. [1905.]
6431. **Raulin, V.** see **Jacquot, E.**
6431. **Ravensworth, Earl.** [Presidential Address.] *Trans. Inst. Naval Archit.*, vol. xxvii, pp. xxvii-xxxvi. [1886.]
6432. **Raverie, —.** Note sur le prétendu volcan de Bakou. *Bull. Sci. Nat. Géol.*, t. xvi, pp. 386-388. [1829.]
6433. **Rawles, W. H. A.** Calorimeter for Volatile Liquid Fuels, specially adapted for Petrol. *Journ. Soc. Chem. Ind.*, vol. xxvi, pp. 665-667. [1907.]
6434. **Rawling, C. G.** Explorations in Dutch New Guinea. *Geogr. Journ.*, vol. xxxviii, pp. 233-255, 592-594, pl. [1911.]
6435. **Ray, S.** Petroleum as a Lubricant in Turning Metals. *Engl. Mech.*, vol. xxiii, pp. 644, 645. [1876.]
6436. **Razoumowsky, G. de.** Histoire naturelle du Jorat et des ses environs. . . . 2 Tt. 8vo, Lausanne, 1789.
6437. **Read, T. T.** Petroleum in Wyoming. *Eng. Min. Journ.*, vol. lxxvii, p. 929. [1904.]
6438. **Reagan, A. B.** [Petroleum in the Olympe District, Washington.] *Mining Eng. World*, vol. xxxv, pp. 425, 426. [1911.]
6439. **Reale-Lauria, G.** Umwandlung der Kohlenwasserstoffe des Petroleums in Alkohole und Fettsäuren durch Verseifung von Walrat. *Chem.-Zeit.*, bd. xxviii, pp. 242, 243. [1904.]
6440. **Rearden, Ph.** Some Occurrences of Gases in a Quicksilver Mine. *Min. Sci. Press*, vol. lxxxiv, pp. 37, 38. [1902.]
6441. **Reclam, —.** Ueber Petroleum. *Gesundheit*, 1876.
6442. **Recoura, —.** see **Berthelot, M.**
6442. **Redfern, P.** On the Nature of the Torbanehill and other Varieties of Coal. *Quart. Journ. Micr. Sci.*, vol. iii, pp. 106-127. [1851.]
6443. **Redfield, S. B.** Long Distance Pumping of Natural Gas. *Amer. Machinist*, vol. xxxii, pt. 1, pp. 880-884. [1909.]
6444. **Redl, F.** Bleichen von Erdwachs. *Zeitschr. Paraff. Industr.*, 1879, p. 57.
6445. ——— Zur Raffination von schweren Schmierölen. *Chem.-Zeit.*, bd. x, p. 760. [1886.]
6446. **Redwood, B.** Testing Paraffin Oil.—Explosion of Lamps. *Engl. Mech.*, vol. xxii, pp. 355, 376, 458. [1875, 1876.]
6447. ——— Description of Mr. B. P. Wilson's Chrono-Thermometer, for use in testing Mineral Oils. *Ibid.*, p. 496. [1876.]
6448. ——— Life in the more recently developed Oil-fields of the United States. *Pharm. Journ. Trans.*, vol. xxxviii, pp. 753-755. [1879.]
6449. ——— The Determination of the Percentage of Oil in Paraffin Scale. *Journ. Soc. Chem. Ind.*, vol. liii, pp. 430-432. [1884.]
6450. ——— The Russian Petroleum Industry. *Ibid.*, vol. lv, pp. 70-81, pl. [1885.]
6451. ——— Petroleum and its Products. *Cantor Lectures*, vol. iii, 1886.
6452. ——— On Viscosimetry, or Viscimetry. *Journ. Soc. Chem. Ind.*, vol. v, pp. 121-133. [1886.]
6453. ——— Notes of a Recent Visit to some of the Petroleum Producing Territories of the United States and Canada. *Ibid.*, vol. vi, pp. 405-412. [1887.]
6454. ——— Petroleum, its production and use. 12mo, New York, 1887. [Published without authority from the author.]
6455. ——— The Oil-Fields of India: Notes on the Petroleum Deposits of Burma, Assam, the Punjab, and Baluchistan. *Journ. Soc. Chem. Ind.*, vol. ix, pp. 359-370. [1890.]
6456. ——— The Galician Petroleum and Ozokerite Industries. *Ibid.*, vol. xi, pp. 93-119. [1892.]
6457. ——— The Transport of Petroleum in Bulk. *Proc. Inst. Civ. Eng.*, vol. cxvi, pp. 177-259, pls. vi-ix. [1894.]
6458. ——— Petroleum: a Treatise on the Geographical Distribution and Geological Occurrence of Petroleum and Natural Gas; The Physical and Chemical Properties, Production, and Refining of Petroleum and Ozokerite; the Characters and Uses, Testing, Transport, and Storage of Petroleum Products, and the Legislative Enactments relating thereto; together with a Description of the Shale Oil and Allied Industries. 2 vols. 8vo, London, 1896.
6459. ——— The Petroleum Sources of the British Empire. *Coll. Guard.*, vol. lxxv, 204, 205, 658. [1898.]
6460. ——— Report on Petroleum Fields of Assam. *Petr. Rev.*, vol. i, pp. 201, 202, 238, 239. [1899.]
6461. ——— Report on the Petroleum Lands of Galicia. *Ibid.*, pp. 203, 204, 237, 238. [1899.]
6462. ——— Uniformity in Methods of Testing Petroleum and its products. 1st Internat. Petrol. Congr., pp. 31-33. [1900.]
6463. ——— Report on a Sample of N'hangelite from Inhambane, Portuguese East Africa. *Bull. R. Bot. Gardens, Kew*, 1907, pp. 151-153.
6464. ——— Liquid Fuel. *Compt. Rend. Congr. internat. Chim. appl.*, sess. 7; Organisation, pp. 61-102. [1910.]

6465. **Redwood, B.**, see **Abel, F. A.**; **Clowes, F.**; and **Thomson, J. H.**
6466. **Redwood, I. I.** Specific Gravities of Paraffin Waxes at Different Temperatures. *Journ. Soc. Chem. Ind.*, vol. viii, pp. 162, 163. [1889.]
6467. ——— A Practical Treatise on Mineral Oils and their By-Products. Including a short history of the Scotch Shale Oil Industry, the Geological and Geographical Distribution of Scotch Shales, Recovery of Acid and Soda used in Oil-Refining, and a List of Patents relating to Mineral Oils. 8vo, London and New York, 1897.
6468. ——— Lubricants, Oils and Greases: Treated Theoretically, and giving Practical Information regarding their Composition, Uses and Manufacture. A Practical Guide for Manufacturers, Engineers, and Users in general of Lubricants. 8vo, London and New York, 1898.
- Reed, W. J.**, see **Taff, J. A.**
6469. **Reed, W. W.** Fuel Oil [S. W. Gas Assoc.] *Amer. Gas Light Journ.*, vol. lxxvi, pp. 695-697. [1902.]
6470. **Reeds, C. A.** A Report on the Geological and Mineral Resources of the Arbuckle Mountains, Oklahoma. *Bull. Oklahoma Geol. Surv.*, no. 3. Pp. 69: 24 pls. [1910.]
6471. **Reerink, —.** Nota omtrent eene rijke Aardolieoort voorkomende op Java. *Tijdschr. Nijverh. Landb. Ned. Ind.*, dl. xi, pp. 362, 363. [1865.]
6472. **Reese, C. L.** Petroleum inclusions in quartz crystals [Guntersville, Alabama]. *Journ. Amer. Chem. Soc.*, vol. xx, pp. 795-797. [1898.]
- Reeve, C. S.**, see **Hubbard, P.**
6473. **Reeve, S. A.** The Evolution of the Internal Combustion Engine. *Trans. Amer. Soc. Mech. Eng.*, vol. xxix, pp. 803-848. [1907.]
- Reformatzky, A. N.**, see **Zelinsky, N. D.**
6474. **Regel, A.** Reisen in Central-Asien, 1876-1879. *Peterm. Mitth.*, bd. xxv, pp. 376-384, 408-417, pl. xx. [1879.]
6475. **Regnand, —.** Sull' Applicazione dell' Olio minerale all' Illuminazione del Farl. *Giorn. Gen. Civ.*, 1874, p. 421.
6476. **Regnault, V.** Recherches sur les combustibles minéraux. *Ann. Mines*, sér. 3, t. xii, pp. 161-240. [1837.]
6477. ——— Note sur un appareil à distillation fractionnée pour apprécier la valeur vénale des huiles essentielles qui proviennent de la calcination des houilles ou des schistes. *Ann. Chim. Phys.*, sér. 3, t. lxxviii, pp. 409-413. [1863.]
6478. **Rehman, —.** [Petroleum and Ozokerite in the Carpathians.] *Naphta*, 1896.
6479. **Rehwagen, A.** Ueber das Vorkommen bituminöser Produkte auf der Insel Barbados. *Berg. Hütt. Zett.*, bd. lx, pp. 467, 468. [1901.]
6480. **Reibenschuh, A. F.** Ueber Krubengas und neuere Beleuchtungstoffe. *Mitth. nat. Ver. Steierm.*, bd. ii, pp. cxlii-cxlv. [1871.]
6481. **Reichardt, E.** Das Steinsalzbergwerk Stassfurt bei Magdeburg. *Mon. Acta Ac. Caes. Leop. Car.*, bd. xxviii, pp. 609-659. [1860.]
6482. ——— Destillation von Petroleum und Ligroin. *Apothek. Zett.*, 1888, p. 12.
- Reichardt, E.**, see **Berlinerbrau, J.**
6483. **Reichenbach, C. v.** Beiträge zur näheren Kenntniss der trockenen Destillation organischer Körper. *Journ. Chem. Phys.*, bd. lix, pp. 436-460. [1830.]
6484. ——— Ueber das Naphthalin. *Ibid.*, bd. lxi, pp. 175-196. [1831.]
6485. ——— Ueber das Paraffin. *Ibid.*, pp. 274-291. [1831.]
6486. ——— Ueber das Eupion. *Ibid.*, bd. lxii, pp. 129-161; bd. lxvi, pp. 318-320. [1831, 1832.]
6487. ——— Einige Bemerkungen über das Paraffin. *Ibid.*, bd. lxv, pp. 295-298. [1832.]
6488. ——— Ueber das Paraffin und das Eupion. *Ann. Phys. Chem.*, bd. c, pp. 173-178. [1832.]
6489. **Reichenbach, C. v.** Ueber das Naphthalin des Herrn Laurent und das Paraphthalin des Herrn Dumas. *Journ. Chem. Phys.*, bd. lxxviii, pp. 223-234, 239-248. [1833.]
6490. ——— Ueber die Entstehung des Steinöls und seine Beziehungen zu den Steinkohlen- und dem Terpenthinöl. *N. Jahrb.*, 1833, pp. 523-533.
6491. ——— Ueber das Steinöl. *Journ. Chem. Phys.*, bd. lxix, pp. 19-29. [1833.]
6492. ——— Ueber das Petroleum oder die Steinöl. *Ibid.*, pp. 133-135. [1834.]
6493. ——— Ueber die Bildung des Steinöls. *Isis*, 1834, pp. 632-634.
6494. ——— Ueber Eupion und Bergnaphtha in Bezug auf die Ansichten des Herrn H. Hess. *Ann. Phys. Chem.*, bd. cxliii, pp. 534-544. [1836.]
6495. **Reichenbach, R. v.** Notiz zur Geschichte des Paraffins. *Journ. prakt. Chem.*, bd. lxiii, pp. 63, 64. [1854.]
6496. ——— Notiz über Paraffin. *Ibid.*, bd. lxxiii, pp. 111-113. [1858.]
6497. **Reid, A.** Chinese Mines and Miners. *Trans. Fed. Inst. Min. Eng.*, vol. xxiii, pp. 26-37. [1902.]
6498. **Reim, F.** Analyse eines aus Petroleumrückständen bereiteten Leuchtgases. *Sitz. k. Ak. Wiss. Wien*, bd. lviii, abth. 2, pp. 87-100. [1868.]
6499. **Rein, —.** [Asphalte Works in Warsaw.] *Inj. Journ.*, 1865, pp. 1155-1175.
6500. **Reinoggs, —.** [Description of the Caucasian Range.] 1796.
6501. **Reinsch, H.** Chemische Untersuchung einiger Braunkohlenarten und technische Versuche mit denselben. *Journ. prakt. Chem.*, bd. xix, pp. 478-495. [1840.]
6502. **Reisel, S.** Beschreibung des Niederbronner Bades, seiner Art, Eigenschaft, Wirkung und Gebrauch. 12mo, Strassbourg, 1664.
6503. **Reissig, W.** [Analysis of Shale-oil Gas.] *Journ. Gasbeleucht.*, bd. v, pp. 131-133. [1862.]
6504. **Remington, J. P.** On the use of petroleum benzine for exhausting oleo-resinous drugs. *Proc. Amer. Pharm. Assoc.*, 1873, p. 592.
6505. **Rémont, A.** Recherche et dosage des huiles lourdes minérales et de résine, des huiles grasses et de la résine dans les huiles du commerce. *Bull. Soc. Chim. Paris*, sér. 2, t. xxxiii, pp. 461-466. [1880.]
6506. **Renard, —.** Traitement et emploi des bitumes asphaltiques de Trinidad. *Propag. Industr.*, 1869, p. 14.
6507. **Renaud, —.** Les gisements bitumineux du Canton de Genève, leur formation géologique, etc. 1877.
6508. **Renaud, G. A. P.** Verslag van een onderzoek naar petroleum in Langkat. *Jaarb. Mijnw. Ned. O.-Ind.*, jg. xix, Techn., pp. 1-9. [1890.]
6509. **Renault, B.** Houille et Bactériacées. *Bull. Soc. Hist. Nat. Autun*, t. ix, pp. 475-500. [1896.]
6510. ——— Les Bactériacées et les Bogheads à Pilas. *Bull. Mus. Hist. Nat. Paris*, 1897, pp. 33-39.
6511. ——— Les Bactériacées des Bogheads. *Ibid.*, pp. 251-258. [1897.]
6512. ——— Notes sur les Bogheads, combustibles anciens, et les Bactériacées qu'ils contiennent. *La Naturaliste*, t. xix, pp. 209-212. [1897.]
6513. ——— Sur quelques Microorganismes des combustibles fossiles. *Bull. Soc. Ind. Min.*, sér. 3, t. xiii, pp. 865-1169; t. xiv, pp. 5-157. [1899, 1900.]
6514. **Renault, B.** and **C. E. Bertrand.** Note sur la formation schisteuse et le Boghead d'Autun. *Ibid.*, sér. 3, t. vii, pp. 499-549, pl. xxiii. [1893.]
- Renault, B.**, see **Bertrand, C. E.**
6515. **Renell, J.** An Account of the Ganges and Barram-pooter Rivers. *Phil. Trans.*, vol. lxxi, pp. 87-114; pl. iv. [1781.]
6516. **Renner, —.** Naphta-Heizung auf Dampfschiffen, im Speclellen bei der Kanal- und Flusschiffahrt. Anregung zur Einführung eines wirtschaftlicheren Heizbetriebes. *Schr. deutsch-öster.-ung. Verb. Binnensch.*, no. xlv. Pp. 23. [1899.]

6517. **Repossi, E.** Gli Scisti bituminosi di Besano in Lombardia. *Atti. R. Acc. Linc.*, ser. 6, Rendic., t. xviii, sem. 1, pp. 197-201. [1905.]
6518. **Requa, M. L.** The Oil Resources of California. An address delivered before the Mining Assoc. University of California. 8vo, Berkeley, 1910.
6519. ——— Petroleum in California in 1910[1911]. *Eng. Min. Journ.*, vol. xcl, pp. 89, 90; vol. xciii, pp. 93, 94. [1911, 1912.]
6520. **Reuleaux, F.** [Sarre's Petroleum-Lamp.] *Sitz. Ver. Beford. Gewerbj.*, 1878, pp. 166, 167.
6521. **Reuleaux, J.** [Les Richesses Minérales du Caucase.] *Rev. Univ. Min.*, sér. 2, t. vii, pp. 242-252. [1880.]
6522. **Reuss, A. E.** Geognostische Beobachtungen gesammelt auf einer Reise nach Tyrol. *N. Jahrb.*, 1840, pp. 127-165, pl. v.
6523. **Reutovski, V. S.** Economic Minerals of Siberia. 8vo, St. Petersburg, 1905.
6524. **Reveley, H. W.** Asphalt. *Journ. Soc. Arts.*, vol. xx, pp. 576, 577, 590, 700, 701. [1872.]
6525. **Roy, A.** L'huile de pétrole; connaissance de l'huile de pétrole dans les temps anciens, importance de son exploitation, procédés pour l'extraire et la raffiner. . . . 8vo, Paris and Geneva, 1805.
6526. **Ribeiro, M. F.** A provincia de S. Thomé e Príncipe suas Dependencias. 8vo, Lisbon, 1877.
6527. **Ricarde-Seaver, T. J.** Oil- and Gas-Wells in Pennsylvania. *Engineering*, vol. xxviii, p. 577. [1884.]
6528. **Ricci, L.** Corografia del territori di Modena Reggio e degli altri State appartenenti alla Casa d'Este. Modena, 1806.
6529. **Ricciardi, L.** Ricerche chimiche sopra una Lignite e alcuni scisti bituminiferi di Giffoni Valle e Piana in provincia di Salerno. *Atti Ac. Gioen. Sci. Nat.*, ser. 3, t. xvi, pp. 123-128. [1882.]
6530. **Rice, G. D.** The Petroleum Industry of the Philippines. *Amer. Gas Light Journ.*, vol. lxxiv, pp. 84, 85. [1901.]
6531. ——— Boring for Natural Inflammable Gas, Oil, etc. *Ibid.*, vol. lxxv, pp. 202, 203. [1901.]
6532. ——— Schemes Worked in Western Oil Country. *Amer. Manuf.*, vol. lvii, 1901.
- Rice, H. E.**, see **Hector, J.**
6533. **Rich, C. J.** Narrative of a Residence in Koordistan and on the Sites of Ancient Nineveh, with Journal of a Voyage down the Tigris to Bagdad and an Account of a Visit to Shiraz and Persepolis. 2 vols. 8vo, London, 1836.
6534. **Rich, F. A.** Report on East Coast Petroleum Fields. (New Zealand.) 1907.
6535. **Richard, A. de.** La Roumanie vue à vol d'oiseau, 1893.
6536. ——— Richesses minérales de la Roumanie. Pétrole, Eaux Minérales, etc. 8vo, Bucharest, 1897.
6537. ——— Monographie du Pétrole de la Roumanie. 8vo, Bucharest, 1897.
6538. ——— (Extrait des Manuscrits de la) Monographie du Pétrole de la Roumanie—Gisements Pétroulières de la Vallée de la Prahova et de la Vallée de Teleajen. Étude géologique et stratigraphique des gîtes du district du Buzeu. 8vo, Bucharest, 1898.
6539. **Richard, G.** La Partie Mécanique des Moteurs à Gaz, et l'Extension récente de leurs Applications. *Mém. Soc. Ing. Civ.*, 1891, t. 2, pp. 487-500.
6540. **Richards, W. S.** Report for 1893 on the Trade of Jeddah. *Dipl. Cons. Rep.*, ann ser., no. 1451. [1894.]
6541. ——— Report for the year 1895 on the Trade of Angora. *Ibid.*, ann. ser., no. 1739. [1896.]
6542. **Richardson, —.** Report on the Trade and Commerce of the Hodeidah District for the years 1905 to 1909. *Ibid.*, ann. ser., no. 4608. [1911.]
6543. **Richardson, C.** Annual Reports of Inspector of Asphalt and Cements, 1889-1892. *Rep. Eng. Dept. D. C.*, 1890-1893.
6544. ——— Softening Agents for the Production of Asphaltic Cements. *Municipal Journ. Sanit. Eng.*, 1897.
6545. ——— On the Nature and Origin of Asphalt. *Journ. Soc. Chem. Ind.*, vol. xvii, pp. 13-32. [1898.]
6546. **Richardson, C.** Notes on Texas Petroleum. *Journ. Soc. Chem. Ind.*, vol. xix, pp. 121-123. [1900.]
6547. ——— Petroleum from the Olinda Field, California. *Ibid.*, pp. 123, 124. [1900.]
6548. ——— The Determination of Paraffin in Petroleum Residues, Asphaltic Oils, and Asphalts fluxed with Paraffin Oils. *Ibid.*, vol. xxi, pp. 690, 691. [1902.]
6549. ——— The Modern Asphalt Pavement. 8vo, New York, 1905.
6550. ——— The Petroleum of North America. A comparison of the character of those of the older and newer fields. *Journ. Franklin Inst.*, vol. cxlii, pp. 57-70, 81-128. [1906.]
6551. ——— The Proximate Composition and Physical Structure of Trinidad Asphalt; with special Reference to the Behaviour of Mixtures of Bitumen and Fine Mineral Matter. *Proc. Amer. Soc. Test. Mat.*, vol. vi, pp. 509-524. [1906.]
6552. ——— Bituminous Materials for Use in and on Road Surfaces and Means of Determining their Character. *Ibid.*, vol. ix, pp. 580-587. [1909.]
6553. ——— Grahamite, a solid native bitumen. *Journ. Amer. Chem. Soc.*, vol. xxxii, pp. 1032-1049. [1910.]
6554. ——— Was Ist Asphalt? *Asphalt-Teerind.-Zeit.*, bd. x, pp. 341, 342. [1910.]
6555. **Richardson, C.** and **C. N. Forrest.** Carbon Tetrachloride and its use as a Solvent for differentiation of Bitumens. *Journ. Soc. Chem. Ind.*, vol. xxiv, pp. 310, 311. [1905.]
6556. ——— Impact Tests of Asphalt Paving Mixtures. *Proc. Amer. Soc. Test. Mat.*, vol. v, pp. 381-387. [1905.]
6557. ——— The Development of the Penetrometer as used in the Determination of the Consistency of Semi-Solid Bitumens. *Ibid.*, vol. vii, pp. 626-637. [1907.]
6558. ——— Methods for the Examination of Bituminous Materials for Road Construction. *Ibid.*, vol. ix, pp. 588-593. [1909.]
6559. **Richardson, C.** and **K. G. Mackenzie.** A Natural Naphtha from the Province of Santa Clara, Cuba. *Amer. Journ.*, ser. 4, vol. xxix, pp. 439-446. [1910.]
6560. **Richardson, C.** and **E. W. Parker.** Asphaltum. *Min. Res. U.S.*, 1893.
6561. **Richardson, C.** and **E. C. Wallace.** Petroleum from the Beaumont, Texas, Field. *Journ. Soc. Chem. Ind.*, vol. xx, pp. 690-693. [1901.]
6562. ——— On the Occurrence of Free Sulphur in Beaumont Petroleum. *Ibid.*, vol. xxi, pp. 316, 317. [1902.]
6563. **Richardson, C. J.** Petroleum as Steam Fuel. *Journ. Roy. United Serv. Inst.*, vol. ix, pp. 70-74, pls. xi, xii. [1865.]
6564. ——— On the use of Petroleum as Steam Fuel. *Chem. News*, vol. xi, p. 39. [1865.]
6565. ——— Liquid Fuel. *Journ. Soc. Arts*, vol. xvi, pp. 504, 505. [1868.]
6566. ——— Petroleum as Steam Fuel. *Engineering*, vol. v, p. 60, fig. [1868.]
6567. **Richardson, F. W.** and **H. N. Hanson.** The Valuation of Lubricants; with Special Reference to Cylinder Oils. *Journ. Soc. Chem. Ind.*, vol. xxiv, pp. 315-319. [1905.]
6568. **Richardson, G. B.** Indiana. Fo. 102, *U.S. Geol. Survey*, 1904.
6569. ——— Natural Gas near Salt Lake City, Utah. *Bull. U.S. Geol. Surv.*, no. 260, pp. 480-483. [1905.]
6570. ——— Salt, Gypsum and Petroleum in Trans-Pecos, Texas. *Ibid.*, pp. 573-585. [1905.]
6571. ——— Petroleum in Southern Utah. *Ibid.*, no. 340, pp. 343-347. [1908.]
6572. **Richardson, Sir John.** Arctic Searching Expedition: a Journal of a Boat Voyage through Rupert's Land and the Arctic Sea in search of the Discovery Ships under Command of Sir John Franklin; with an Appendix on the Physical Geography of North America. 2 vols. 8vo, London, 1851.
6573. **Riche, A.** Vaseline, Pétréoline. *Journ. Pharm. Chim.*, sér. 5, t. xxii, pp. 518-527. [1890.]

6574. Riche, A., and G. Halphen. Nouvelles recherches sur les Pétales. *Journ. Pharm. Chim.*, sér. 5, t. xxx, pp. 289-300. [1894.]
6575. ———. Le Pétrôle. *Paris*, 1896.
6576. Riche, A., and — Roume. L'Industrie du Pétrôle aux États Unis d'Amérique. *Ann. Mines*, sér. 9, t. v, pp. 67-130, map. [1894.]
6577. Richmond, G. F. Tayabas Petroleum. *Philippine Journ. Science*, vol. v, pp. 1-7. [1910.]
6578. Richon, —. Le Pétrôle. Histoire, origine, extraction, traitement, industriel, emplois du pétrole; ses dérivés, leurs usages, accidents produit par le pétrole; moyens de les éviter. *Metz*, 1866.
6579. Richter, G. [Deep Boring, Zsibo.] *Bányász. Kohász. Lapok*, evf. xxxii. [1899.]
6580. Richter, M. M. Die Benzinbrände in den chemischen Waschereien. 8vo, *Berlin*, 1903.
6581. ———. Gutachten über die auf dem Gebiete der Gemeinden Mikova und Habura in Comitae Zemplen zu bewerkstelligenden Petroleum-Bohrungen. *Bányász. Kohász. Lapok*, evf. xxx, no. 7. [1897.]
6582. Richthofen, F. v. Die Kalkalpen von Vorarlberg und Nord Tirol. *Jahrb. k.-k. geol. Reichs.*, bd. x, pp. 72-141; bd. xii, pp. 87-206. [1859, 1862.]
6583. ———. Studien aus den ungarischsiebenbürgischen Trachytegebirgen. *Ibid.*, bd. xi, pp. 163-278. [1860.]
- Richthofen, F. F. v., see Hauer, F. R. v.
6584. Rickard, F. J. Informe sobre los distritos minerales minas y establecimientos de la Republica Argentina en 1868-90. *Buenos Ayres*, 1869.
6585. Ricketts, C. On Bitumen in the Paleozoic Rocks of Shropshire. *Proc. Liverpool Geol. Soc.*, vol. v, pp. 131-135. [1886.]
6586. Ricketts, L. D. Annual Reports of the Territorial Geologist to the Governor of Wyoming. 8vo, *Cheyenne, Wyo.*, 1888-1890.
6587. Ridgway, T. S. Report on the Oil District of Oil Creek in the State of Pennsylvania. *Journ. Franklin Inst.*, vol. xlv, pp. 269-273. [1863.]
6588. Riebeck, E. Beiträge zur Kenntniss des Pyropisits. *Freiburg-i-B.*, 1880.
6589. Riedemann, W. A. The Advent of the Bulk Oil-Carrying Steamers. *Petr. Rev.*, vol. xxii, pp. 315, 316. [1910.]
- Riemer, J., see Ahrens, F. B.
6590. Rieppel, P. Versuche über die Verwendung von Teerölen zum Betrieb des Dieselmotors. *Zeitschr. Ver. deutsch. Ing.*, bd. li, pp. 613-618. [1907.]
6591. Ries, H. Economic Geology of the United States. *New York*, 1905.
6592. ———. Clay and Shale Deposits of Western Canada. *Summ. Rep. Geol. Surv., Canada*, for 1910, pp. 174-180. [1911.]
6593. Rigand, F. La Formation de la houille. *Rev. Sci.*, sér. 4, t. ii, pp. 385-396. [1894.]
6594. ———. Sur les Combustibles Naturels. *Rev. Univ. Min.*, sér. 4, t. xxxi, pp. 145-174. [1910.]
6595. Rispler, A. Heizung mit Teerölen. *Oesterr. Zeitschr. Berg-Hütt.*, bd. liii, pp. 548-550, pl. xvii. [1905.]
6596. Rispoloschenski, R. [Search for Asphalt in S.E. Samara-Luka.] *Trudi Estestv. Obsch. Kazansk. Univ.*, t. xxvi, pp. 1-54, pl. [1893.]
6597. Ritckov, P. [On a combustible earth from the Orenburg Government.] *Trudi Voln. Ekon. Obsch. St. Petersburg.*, t. ix, pp. 83-91. [1768.]
6598. Ritter, C. v. Die Erdkunde im Verhältnis zur Natur und zur Geschichte des Menschen. . . . 8vo, *Berlin*, 1817-1818.
6599. Rivière, —. Note sur la distillation des schistes bitumineux. 1839.
6600. Rivière, A. Note sur l'origine des combustibles minéraux. *Compt. Rend.*, t. xvii, pp. 646-648. [1858.]
6601. Rivière, L. [Mémoire on some Peculiarities of the Lands of Gabian, and chiefly on the Fountain of Petroleum which flows there.] *Montpellier*, 1717.
6602. Robb, C. On the Petroleum Springs of Western Canada. *Canad. Journ.*, n.s., vol. vi, pp. 313-324. [1861.]
6603. Roberto, U. Osservazioni sullo studio e sulla coltivazione di giacimenti oleiferi. *Rass. Min.*, t. xxxii, pp. 281-284. [1910.]
6604. Roberts, R. W., and A. Fraser. Easy Process for estimating Water in Petroleum. *Journ. Soc. Chem. Ind.*, vol. xxix, pp. 197, 198. [1910.]
6605. Roberts, T. P. Long Distance Transportation of Natural Gas. *Proc. Eng. Soc. West. Penns.*, 1885-1887, pp. 79-87.
6606. ———. Notes on Transportation of Gas. *Ibid.*, pp. 89-92.
6607. Robertson, J. R. M. The Oil and Oil Wells of Burmah, with Notes on the Geology of the Districts of their Occurrence. *Trans. Geol. Soc. Glasgow*, vol. vi, pp. 226-247, pl. vii. [1882.]
6608. ———. The Occurrence of Torbanite or Kerosene Coal in the Colony of New South Wales. *Trans. Min. Inst. Scotland*, vol. xiv, pp. 88-112. [1892.]
6609. Robinson, —. Oil Boring in Missouri. *Eng. Min. Journ.*, vol. iv, p. 297; vol. v, p. 261. [1868.]
6610. Robinson, C. J. The Occurrence of Acetaldehyde in Petroleum Products. *Journ. Soc. Chem. Ind.*, vol. xviii, p. 232. [1899.]
6611. Robinson, E. Biblical Researches in Palestine, Mount Sinai, and Arabia Petraea, 1838. 3 vols 8vo, *London*, 1841.
6612. Robinson, G. C. On some New Bases of the Lencoline Series. Part I (and with W. L. Goodwin), Parts II and III. *Trans. Roy. Soc. Edinb.*, vol. xxviii, pp. 561-570; xxix, pp. 265-272, 273-279. [1880.]
6613. Robinson, W. A Descriptive Account of Assam, with a sketch of the local geography. *Calcutta*, 1841.
6614. ———. The Uses of Petroleum in Prime Motors. *Journ. Soc. Arts*, vol. xxxix, pp. 492-516, 553, 554. [1892.]
6615. ———. The Uses of Petroleum in Prime Movers. *Cantor Lectures*, vol. iv, 1892.
6616. ———. Gas and Petroleum Engines: a practical Treatise on the Internal Combustion Engine. 8vo, *London*, 1890.
6617. Roch, —. Études chimiques et médicales sur les sources bitumineuses d'Auzon (Gard).
6618. RoCHAT, L. Le gisement bitumineux du canton de Genève. 1877.
6619. Rochleder, F. Ueber eine bituminöse Substanz. *Sitz. k. Ak. Wiss. Wien.*, bd. vi, pp. 53-55. [1851.]
6620. RoCHON, A. Voyage à Madagascar et les Indes Orientales. 8vo, *Paris*, 1791.
6621. Rock, T. D. Fossil Hydrocarbons. The source of Heat, Light, Colour, etc. *Technologist*, vol. ii, pp. 215-224. [1862.]
6622. Rocketteller, J. D. *Memorien. Berlin*, 1909
6623. Rodakowski, —. Das Erdöl als Brennmaterial für die Industrie. *Naphtha*, bd. x, pp. 135, 136. [1902.]
6624. Rodriguez, B. L'Asphalte de Banas [Cuba]. *Rev. Univ. Mines*, sér. 2, t. iv, pp. 756-759. [1878.]
6625. Rodwell, G. F. On the Coefficient of Expansion of a Paraffine of High Boiling Point. *Proc. Roy. Soc.*, vol. xxiii, pp. 108-116. [1875.]
6626. Roebuck, J. W. Industrial Motor Vehicles. *Proc. Inst. Automob. Eng.*, vol. vii. [1906.]
6627. Röhming, E. Das doppelagige Asphaltpappdach; Hoppe und Röhming. 8vo, *Halle* (Ed. iii), 1897.
6628. Röhrig, E. Das Vorkommen des Petroleums, mit spezieller Berücksichtigung der Ansichten, welche dasselbe im nordwestlichen Deutschland für die Zuckerei darbietet. *Hanover*, 1882.
6629. Römer, F. Das Vorkommen des Ozokerits oder Erdwachs und begleitende Fossilien in der Sobieski-grube bei Truskawiec. 63rd *Jahresb. schles. Ges.*, p. 119. [1886.]
6630. Römer, H. Erläuterungen zu den ersten zwei Blättern einer geognostischen Karte des Königreichs Hannover, die Gegend zwischen Hildesheim und Nordheim umfassend. *Zeitschr. deutsch. geol. Ges.*, bd. iii, pp. 478-530. [1851.]



6631. **Römer, H.** Das Asphalt-Vorkommen bei Limmer und am Hils. 1872.
6632. ——— Ein neuer Aufschluss der Wälderthon- und Hilsthonbildung. *Zeitschr. deutsch. geol. Ges.*, bd. xxvi, pp. 345-348. [1874.]
6633. ——— Petroleum zwischen Hannover und Braunschweig. 1880.
6634. **Rössler, A. R.** Geologische Untersuchungen in Texas. *Verh. k.-k. geol. Reichs.*, 1863, pp. 188-190.
6635. ——— Geological Sketch of the Sour Lake region, Hardin County, Texas. *Texas State Register*, vol. xvi, pp. 93-95. [1876.]
6636. **Röttger, W.** Vorläufige Notiz über einen neuen Körper aus Petroleum. *Zeitschr. Chem.*, f. 2, bd. ii, p. 210. [1866.]
- Rogers, A. F.**, see **Haworth, E.**
6637. **Rogers, A. F.** The New Oil Field in Utah. *Eng. Min. Journ.*, vol. lxxxvii, p. 989. [1909.]
6638. **Rogers, H. D.** The Geology of Pennsylvania. 2 vols. 4to, Philadelphia, 1853.
6639. ——— On the Distribution and Probable Origin of the Petroleum or Rock-Oil of Western Pennsylvania, New York, and Ohio. *Proc. Phil. Soc. Glasgow*, vol. iv, pp. 355-359. [1860.]
6640. ——— Coal and Petroleum. *Harper's Mag.*, vol. xxvii, p. 259. [1863.]
6641. ——— On Petroleum. *Proc. Phil. Soc. Glasgow*, vol. vi, pp. 43-61. [1868.]
6642. **Rogers, R. E.** Petroleum-Wells of Ohio. *Proc. Ac. Nat. Sci. Philad.*, 1860, p. 147.
6643. **Rogers, W. B.** Observations on the Structural and geological relations of the Albertite, or so-called Albert Coal of New Brunswick. *Proc. Acad. Nat. Sci. Philad.*, 1860, p. 98.
6644. **Rogissart, — de.** Les Délices de l'Italie. 3 T. 8vo, Leyden, 1706.
6645. **Roha, B.** Die Kohlen- und Eisenwerkcomplex Anina-Steierdorf im Banat. *Jahrb. k.-k. geol. Reichs.*, bd. xvii, pp. 63-76. [1867.]
6646. **Rojas, A.** El Lago de Asfalto en la Isla de Trinidad. *Estudio geológico*. . . 8vo, Caracas, 1869.
6647. **Rojetvskii, A. L.** [Fuel Oil for Industrial Purposes. The Tchelenko Oil Fields.] *Russ. Ministr. Trade and Industry*, 1907.
6648. **Rolker, C. M.** Notes on the Elmore Concentration Process. *Trans. Inst. Min. Metall.*, vol. viii, pp. 379-395, pl. xxxvi. [1900.]
6649. **Rolleston, G. H. F.** Petroleum in New Zealand. *Board Trade Journ.*, vol. lxxviii, p. 256. [1910.]
6650. **Rollier, L.** Gisement de Dysodite à Oberdorf piés Soleure. *Ecl. Geol. Helvet.*, t. viii, pp. 412-414. [1905.]
6651. **Romanis, R.** On the Outcrops of Coal in the Myanong division of the Henzada District. *Rec. Geol. Surv. Ind.*, vol. xv, pp. 178-181, map. [1882.]
6652. ——— Report on the Yenanchang Oil-wells. *Fo, Rangoon*, 1884.
6653. ——— Report on the Oil-Wells and Coal in the Thayetmyo District, British Burma. *Rec. Geol. Surv. Ind.*, vol. xviii, pp. 149-151. [1885.]
6654. ——— Notes on Burmese Petroleum. *Chem. News*, vol. lix, p. 292. [1889.]
6655. **Romanovski, G.** [Catching Clutch.] *Gorn. Journ.*, 1859, t. 4, pp. 532-539.
6656. ——— [Boring Tools and Methods, for large holes.] *Gorn. Journ.*, 1862, t. 2, pp. 1-29.
6657. ——— [Oil, Asphalt, and Combustible Shale of the Volga.] *Ibid.*, 1864, t. 4, pp. 421-424.
6658. ——— [Self-rotating Freefall Boring Tool.] *Ibid.*, 1866, t. 1, pp. 333-336.
6659. ——— [On Borings in Europe and on Illuminating Materials.] *Ibid.*, t. 2, pp. 41-55.
6660. ——— [On Petroleum generally, and North American Oil in particular.] *Ibid.*, pp. 473-506; t. 3, pp. 101-124, 233-262.
6661. ——— [On the Samara Oil-springs. . .] *Ibid.*, 1868, t. 3, pp. 204-220.
6662. **Romanovski, G.** [Remarks on W. Mather's Boring Apparatus.] *Gorn. Journ.*, 1869, t. 1, pp. 460-462.
6663. ——— [Caucasian Oil as the Future Source of Imperial and Social Wealth.] *Ibid.*, t. 2, pp. 303-315.
6664. **Romanovski, G. D.** [Oil-springs and Production in the Kuban Province and the Taman Peninsula.] *Ibid.*, 1870, t. 4, pp. 463-503; 1873, t. 2, pp. 1-20.
6665. ——— [Notes on the Kuban Oil-fields.] *Ibid.*, 1873, t. 3, pp. 176-181.
6666. ——— Materialien zur Geologie von Turkestan. 4to, St. Petersburg, 1878, 1884, 1890.
6667. **Romanovski, G. D.**, and **L. Muschketov.** Carte géologique du Turkestan Russe. 1 : 1,260,000 (6 sheets). *St. Petersburg*, 1886.
6668. **Romé Delisle, J. B. L. de.** Crystallographie, ou Description des formes propres à tous les corps du règne minéral. 8vo, Paris, 1771.
6669. **Rominger, C.** Geological Survey of Michigan, Lower Peninsula, 1873-1876, accompanied by a Geological Map. Vol. iii. 8vo, New York, 1876.
6670. **Rommenhöller, —.** La Roumanie. *Rotterdam*, 1898.
6671. **Ronalds, E.** On the most volatile Constituents of American Petroleum. *Trans. R. Soc. Edinb.*, vol. xxiii, pp. 491-498. [1864.]
- Roncali, F.**, see **Paris, G.**
6672. **Roots, J. D.** Petroleum Motor Vehicles. *Trans. Soc. Eng.*, 1899, pp. 95-132, 10 pls.
6673. ——— The Cycles of Gas and Oil Engines. 8vo, London, 1899.
6674. **Rosaer, O.** Ueber eine zweckmässige Einrichtung des Klärtaales einer Kerzenfabrik. *Seifen- u. Zeit.*, bd. xxxvi, pp. 413, 414, 440, 441, 469, 470. [1909.]
- Rose, F.**, see **Kast, H.**
6675. **Rose, G.** Mineralogisch-geognostische Reise nach dem Ural, dem Altai und dem Kaspische Meere. 2 Bde. 8vo, Berlin, 1837-1842.
6676. **Rose, H.** Ueber das Knistersalz von Wieliczka. *Ann. Phys. Chem.*, bd. ccxv, pp. 353-360. [1839.]
6677. **Rosenberg, L. V.** Masutfeuerungen für Ziegeleien. *Petroleum Zeitschr.*, bd. ii, pp. 704-708. [1907.]
6678. **Rosenblat, Th.** Bestimmung der Entflammungstemperatur des Petroleums. *Chem.-Zeit.*, bd. x, p. 1587. [1886.]
6679. **Rosenfeld, —.** Technische Untersuchungen über rumanischen Petroleum. 8vo, Munich, 1909.
6680. **Rosengren, C.** Das Wollfett und die Wollfettsäuren, und die Anwendung der letzteren zum Festmachen des Petroleums. *Chem.-Zeit.*, bd. xxiii, p. 382. [1899.]
6681. **Rosenhain, W.** The Calorimetry of Volatile Liquids. *Journ. Soc. Chem. Ind.*, vol. xxv, pp. 239-241. [1906.]
6682. **Rosenthal, T.** Ein Ausflug nach Wietze. *Braunkohle*, bd. iii, p. 535. [1904.]
6683. ——— Die Untersuchung des Rohpetroleum, auf Wasser und Fremdkörper. *Petroleum Zeitschr.*, bd. v, pp. 22-25. [1909.]
6684. ——— Die Entwasserung von rohem Erdöl. *Ibid.*, pp. 315, 316. [1909.]
6685. ——— Ein neuer Apparat für kontinuierliche Destillation von Teeren und Oelen. *Chem.-Zeit.*, bd. xxxiv, pp. 1278, 1279. [1910.]
6686. ——— Ein neuer Destillierapparat für Teere und Mineralöle. *Zeitschr. angew. Chem.*, bd. xxiii, pp. 1269, 1970. [1910.]
6687. ——— Ueber die Lagerung von Benzin und anderen feuergefährlichen Flüssigkeiten. *Ibid.*, bd. xxiv pp. 289, 290. [1911.]
6688. ——— Die physikalischen und chemischen Eigenschaften der bituminösen Wegematerialien in den Vereinigten Staaten. *Asphalt-Teerind.-Zeit.*, bd. xi, pp. 81, 82, 104, 120, 121. [1911.]
- Rosicky, V.**, see **Plzak, F.**
6689. **Rosinski, P.** [Carpathan Oil-fields of Gallicia, Bukowina, Rumania and Hungary.] *Gorn. Journ.*, 1866, t. 1, pp. 71-121.

6690. **Rosinski, P.** [Petroleum Regions in America.] *Gorn. Journ.*, 1887, t. 1, pp. 385-441.
6691. **Roskiewicz, —** Studien über Bosanien und die Herzegovina, 8vo, *Leipzig and Vienna*, 1868.
- Rosner, L., see Engler, C.**
6692. **Rosok, T. A.** Turbine Station of the Bisbee Improvement Company. (Results of Arizona Oil-burning plant.) *Electr. World*, vol. lvi, pp. 661-664. [1910.]
6693. **Ross, A. C.** Argentine. Petroleum Deposits. *Board of Tr. Journ.*, vol. lxxviii, p. 403. [1910.]
6694. **Ross, C. W.** Report for 1889 on the Trade of South Persia. *Dipl. Cons. Rep.*, ann. ser., no. 629. [1889.]
6695. **Ross, F. E.** Mining Operations in Peru in 1910. *Eng. Min. Journ.*, vol. xci, pp. 463-465. [1911.]
6696. **Ross, O. C. D.** Petroleum and other Mineral Oils applied to the Manufacture of Gas. *Proc. Inst. Civ. Eng.*, vol. xl, pp. 150-152. [1875.]
6697. ——— Air as Fuel, or Petroleum and other Mineral Oils utilized by Carburetted Air and rendering it inflammable. 8vo, *London*, 1874.
6698. ——— The Origin of Petroleum. *Rep. Brit. Assoc.*, 1891, pp. 639, 640. [1892.]
6699. **Ross, R., and J. P. Leathes.** The Constitution of Gas Oils. *Journ. Soc. Chem. Ind.*, vol. xxi, pp. 676-680. [1902.]
6700. ——— On the composition and valuation of oils used for gas-making purposes. *Analyst*, vol. xxxi, pp. 284-298; vol. xxxii, pp. 241-246. [1906, 1907.]
6701. **Rosset, A.** [Discovery of Oil in the Caucasus.] *Kosmos*, t. xi, pp. 669, 670. [1886.]
6702. **Rossmässler, F. A.** Die Paraffin- und Mineralöl-Fabrikation am Kaukasus. *Deutsch. IU. Gewerbezeit.*, bd. xxvii, pp. 88-90. [1862.]
6703. ——— [Short Sketch of the Mode of Preparation of Photogen from Apscheron Petroleum.] *Zap. Kavk. Otd. Imp. Russk. Tekhn. Obsch.*, t. ii, pp. 18, 19. [1869.]
6704. ——— [Statistics of the Photogen Industry of the Apscheron Peninsula.] *Ibid.*, otd. iii, pp. 16, 17. [1869.]
6705. ——— Fabrikation von Photogen, etc., aus Baku'scher Naphta. *Halle*, 1884.
6706. ——— Lehrbuch der Verarbeitung der Naphta oder des Erdöls auf Leucht- und Schmieröle. 8vo, *Vienna*, 1885.
6707. ——— Die Petroleum- und Schmierölfabrikation. *Leipzig*, 1893.
6708. ——— Chemie der gesamten Oelindustrie. 8vo, *Vienna*, 1907.
6709. ——— Die flüssigen Heizmaterialien und ihre Anwendung. 8vo, *Vienna*, 1910.
6710. **Rostomian, M.** The Deterioration of Illuminating Oils. *Petr. Rev.*, vol. iv, pp. 182, 183, 230, 231, 307, 308, 332, 333, 347, 348. [1901.]
6711. **Roth, J.** Der Vesuv. *Berlin*, 1837.
6712. **Roth v. Telegd, L.** Bericht über den in Bucuresti abgehaltenen III. Internationalen Petroleum-Kongress. *Jahresb. k. ung. geol. Anst.*, 1907, pp. 315-325. [1909.]
6713. **Roti, —** Rapporto sulle sorgenti di petrolio di Ras Gamsah nel golfo di Suez. *Boll. Cons.*, vol. xxii, pt. 1, pp. 473-477. [1886.]
6714. **Rouen, —**, see **Buson-Dumaurier, —**
6715. **Rougemaitre, —** [Walsbronn Petroleum Spring, Lorraine.] *Prize Essay, Acad. Nancy*, 1755.
6716. **Roume, —**, see **Riche, A.**
6717. **Rosset, E.** Les Bitumes de la Trinité et leur application à la préparation du gaz. *Journ. Eclair. Gaz.*, t. xix, p. 180. [1871.]
6718. **Routala, F. O.** Ueber die Bildung der Naphthene im Erdöl. [Inaug. Diss.] 8vo, *Karlsruhe*, 1910.
- Routala, F. O., see Engler, C.**
6717. **Routledge, R.** Discoveries and Inventions of the Nineteenth Century. 8vo, *London*, 1870.
6718. **Roux, —** The Use of Petroleum in the Manufacture of Coal Briquettes. 1st *Internat. Petrol. Congr.*, pp. 80, 81. [1900.]
6719. **Rowan, F. J.** On the Physical Conditions existing in Shale-distilling Retorts. *Journ. Soc. Chem. Ind.*, vol. x, pp. 436-443. [1891.]
6720. **Rowbotham, J. McK.** Mineral Resources of the Argentine Republic. *Proc. Inst. Civ. Eng.*, vol. cxviii, pp. 337-340. [1897.]
6721. ——— Mines and Mining in the Argentine Republic. *Ibid.*, vol. clx, pp. 290-294. [1905.]
6722. **Rowland, J. F., jun.** Fuel Oil. *Journ. Franklin Inst.*, vol. clvi, pp. 139-141. [1903.]
6723. **Rowley, —** Report on the Trade of Santo Domingo for the year 1906. *Dipl. Cons. Rep.*, ann. ser., no. 3842. [1907.]
6724. **Rowntree, W. B.** Use of Crude Oil in Converters. *Eng. Min. Journ.*, vol. lxxxiv, p. 639. [1907.]
6725. **Roy, Alfred.** Third Annual Report to the Governor of the State of Ohio, on the Mineral Resources. 1877.
6726. **Royer, E.** Essai sur la constitution chimique de l'huile de schiste. *Mém. Soc. Sci. Phys. Nat. Bordeaux*, t. ii, pp. 285-292. [1862.]
6727. **Rozet, —** [Observations in the Jura; Pyrimont Asphalt Mines.] *Bull. Soc. Géol. France*, t. vii, pp. 136-143. [1835.]
6728. **Rozsay, J.** [Peklenica Petroleum.] *Jahrb. Wandervers. ung. Aerzte Nat.*, 1864.
6729. **Rudevitch, V.** [On  $\beta$ -decanaphthene of Caucasian Petroleum.] *Jurn. Russk. Fiz. Khim. Obsch.*, t. xxv, otd. 1, pp. 385-389. [1893.]
6730. **Rudnev, V.** Ueber die Produkte der Destillation des Petroleumsgastheers. *Polyt. Journ.*, bd. ccxxxix, pp. 72-74. [1881.]
6731. **Rudnev, V., and S. Langovoi.** [Grozni Petroleum.] *Gorn. Journ.*, 1898, t. 3, pp. 231-237.
6732. **Rudra, S. C.** Mineral Resources of British India. *Trans. Amer. Inst. Min. Eng.*, vol. xxxiv, pp. 804-835. [1904.]
6733. **Rudsky, M., see Zelinsky, N. D.**
6733. **Rübezahl, F. H.** Petroleum. *Ung. Montanind. Zeit.*, 1887.
- Rücker, A. W., see Thorpe, T. E.**
6734. **Rügner, —** Das Petroleum-Magazin zu Frankfurt-am-Main. *Deutsch. Bauzeit.*, bd. ix, pp. 64, 65. [1875.]
6735. **Rühemann, —** Qualitativer Nachweis von fettem Oel in Mineralöl. *Mith. k. techn. Versuchsanst.*, bd. x, pp. 306-314. [1892.]
- Rüst, D., see Fischer, H.**
6736. **Ruland, Martin.** Badebüchlein, Schröpfbüchlein, Aderlassbüchlein, darinne angezeigt wird, wie alle Krankheiten durch Wasserbäder, Schweissbäder u. d. g. geheilt werden. 1564.
6737. **Rumbold, H.** Report for 1886 on the Trade of Greece. *Dipl. Cons. Rep.*, ann. ser., no. 194. [1887.]
6738. **Rumpf, J.** Ueber den Harlit aus der Kohle von Oberdorf und den angrenzenden Gebieten von Voitsberg und Köflach in Steiermark. *Sitz. k. Ak. Wiss., Wien*, bd. lx, Abth. 2, pp. 91-100, 2 pls. [1869.]
6739. **Russegger, J.** Ueber den Asphalt, sein Vorkommen in Tirol, seine technische Bedeutung und seine Gewinnung. *Ber. Ver. geogn.-montan. Durchf. Tirol*, no. 7, pp. 23-46. [1845.]
6740. ——— Reisen in Europa, Asien, und Afrika, mit besonderer Rücksicht auf die naturwissenschaftlichen Verhältnisse der betreffenden Länder. 7 Bde. 8vo, *Atlas fo, Stuttgart*, 1841-1849.
6741. **Russell, I. C.** On the Occurrence of a Solid Hydrocarbon in the Eruptive Rocks of New Jersey. *Amer. Journ. Sci.*, ser. 3, vol. xvi, pp. 112-114. [1878.]
6742. ——— Notes on the Geology of Southwestern Idaho and Southeastern Oregon. *Bull. U.S. Geol. Surv.*, no. 217. Pp. 83; 13 pls. [1903.]
6743. **Russig, —** Treiböle und Oelmotoren. *Asphalt-Teerind.-Zeit.*, bd. vii, pp. 386-388, 404, 405. [1907.]
6744. **Russer, J.** Ueber die Wärmeausdehnung des Schwefels, Kautschuks, Hartgummi, der Gutta-percha und des Paraffins, sowie über die Verwendbarkeit des Hartgummi zu Compensationspendeln. *Rep. Exp. Phys.*, bd. xviii, pp. 152-177. [1882.]

6745. **Rust, R.** The Petroleum Deposits of Trinidad. *Petroleum Rev.*, vol. xiv, pp. 293-294. [1906.]
6746. ——— The Oil Fields of Trinidad. *Petrol. World*, vol. vii, 216, 217, 256-258. [1910.]
6747. **Rutherford, J.** Notes on the Albertite of New Brunswick. *Journ. Fed. Canad. Min. Inst.*, vol. iii, pp. 40-46, map. [1898.]
6748. **Ryabinin, A. N.** [Geological Investigation of certain Oil-fields of the Signakh district, Tiflis province, on the left bank of the Jora.] *Bull. Com. géol. Russ.*, t. xxii, pp. 163-228, pl. v. [1903.]
6749. ——— [The Caspian Coastal Steppes and the Ust-Urt, from the Ural river to the mouth of the Amu Daria.] *Gorn. Journ.*, 1905, t. 1, pp. 104-127, 242-272.
6750. ——— [Geological Operations in 1905 in the Binagadi Oilfield, Baku.] *Bull. Com. géol. Russ.*, t. xxv, pp. 145-182. [1906.]
- Ryabinin, A. N.**, see **Golubytznikov, D. V.**
6751. **Rzehak, A.** Petroleumvorkommen in mährisch-schlesischen Grenzgebirge. *Zeitschr. prakt. Geol.*, bd. xiii, pp. 5-12. [1905.]
6752. **S——, L.** Ueber Torpedierung der Oelbohrlöcher. *Naphtha*, bd. xv, pp. 390-392. [1907.]
6753. **S——, N.** Ueber Naphtha im Kaukasus. *Berg-Hütt. Zeit.*, bd. li, pp. 287-289. [1892.]
6754. ——— Das Project einer Naphthaleitung vom Kaspischen Meer zum Persischen Meerbusen. *Ibid.*, bd. liii, p. 137. [1894.]
6755. ——— Die Mineralreichthümer Turkestans. *Ibid.*, bd. lvi, pp. 57, 58. [1897.]
6756. **S——, O.** Die Petroleumfelder in Westafrika. *Petroleum Zeitschr.*, bd. iv, pp. 985, 986. [1909.]
6757. **S——, P.** Neuere Verbrennungskraftmaschinen für die Erdölindustrie. *Ibid.*, bd. vi, pp. 971-975. [1911.]
6758. **S——, R. P.** The Rocks in which Petroleum is found. *Sci. Amer.*, ser. 2, vol. xi, pp. 314, 315. [1864.]
6759. **Sabatier, A.** Nouvelles Méthodes de Fabrication de Gaz d'Éclairage. *Compt. Rend. Congr. internat. Chim. appl.*, sess. 6, t. liii, pp. 188-195. [1907.]
6760. **Sabatier, P.** Synthèse de Pétoles par hydrogenation de l'acétylène en présence de divers Métaux. *Journ. Pér.*, t. i, pp. 67, 68. [1901.]
6761. **Sabatier, P.**, and **J. B. Senderens.** Action du nickel sur l'éthylène. *Compt. Rend.*, t. cxxiv, pp. 616-618. [1897.]
6762. ——— Action du nickel sur l'éthylène. Synthèse de l'éthane. *Ibid.*, pp. 1358-1361. [1897.]
6763. ——— Hydrogenation de l'acétylène en présence du nickel. *Ibid.*, t. cxxviii, pp. 1173-1176. [1899.]
6764. ——— Hydrogenation de l'éthylène en présence de divers métaux réduits. *Ibid.*, t. cxxx, pp. 1761-1764. [1900.]
6765. ——— Hydrogenation de l'acétylène et de l'éthylène en présence du platine divisé. *Ibid.*, t. cxxxi, pp. 40-42. [1900.]
6766. ——— Action de divers métaux divisés, platine, cobalt, fer, sur l'acétylène et sur l'éthylène. *Ibid.*, pp. 267-270. [1900.]
6767. ——— Méthode générale de synthèse des naphthènes. *Ibid.*, t. cxxxii, pp. 566-568. [1901.]
6768. ——— Nouvelles synthèses du méthane. *Ibid.*, t. cxxxiv, pp. 514-516. [1902.]
6769. ——— Hydrogenation des carbures éthyliques par la méthode de contact. *Ibid.*, pp. 1127-1130. [1902.]
6770. ——— Synthèse de divers Pétoles: Contribution à la Théorie de Formation des Pétoles naturels. *Ibid.*, t. cxxxiv, pp. 1185-1188. [1902.]
- Sabatier, P.**, see **Haller, A.**
6771. **Sacco, F.** L'Appennino settentrionale (parte centrale). *Boll. Soc. Geol. Ital.*, vol. x, pp. 731-956, pls. xxii, xxiii. [1891.]
6772. ——— L'Appennino dell' Emilia. *Ibid.*, vol. xi, pp. 425-614. [1892.]
6773. **Sachse, J. H.** Das Erdölvorkommen im nordwestlichen Deutschland. *Naphtha*, bd. x, pp. 301-304, 316-321. [1902.]
6774. ——— Das Erdölvorkommen in Hannover und Braunschweig. *Chem. Rev. Fett-Harz-Ind.*, bd. x, pp. 2-5, 36. [1903.]
6775. **Sadler, J. H.** Report for 1887, 1889 on the Trade of Chicago. *Dipl. Cons. Rep.*, ann. ser., nos. 330, 739. [1888, 1890.]
6776. **Sadler, S. P.** Appendix on the Hydrocarbon Compounds to Dr. F. A. Genth's Report on the Mineralogy of Pennsylvania. *2nd Geol. Survey Penns.*, B. 8vo, Harrisburg, 1875.
6777. ——— Analyses of Gas issuing from Oil Wells. *Ibid.*, L, App. B, pp. 146-160. 8vo, Harrisburg, 1876.
6778. ——— On the Chemical Composition of Pennsylvania Petroleum. *Amer. Chem.*, vol. vii, pp. 181-183. [1876.]
6779. ——— On the Composition of the Natural Gas from certain Wells in Western Pennsylvania. *Proc. Amer. Phil. Soc.*, vol. xvi, pp. 206-211, 585-589. [1876, 1877.]
6780. ——— [The Presence of Higher Olefines in Pennsylvania Petroleum. *Ibid.*, vol. xviii, pp. 44, 45. [1878.]
6781. ——— Russian and American Petroleum. *Journ. Franklin Inst.*, vol. cxxiii, pp. 364-375. [1888.]
6782. ——— The Technical Utilizations of Petroleum and its Products. *Min. Industry*, vol. iv, pp. 503-509. [1895.]
6783. ——— Asphalts and Bitumens. *Journ. Franklin Inst.*, vol. cxi, pp. 198-211. [1895.]
6784. ——— On the Technical Analysis of Asphalts. *Ibid.*, pp. 383-386. [1895.]
6785. ——— Some Results obtained in the Destructive Distillation of Lined Oil. With Remarks on its bearing on Engler's Theory of the Origin of Petroleum. *Amer. Journ. Pharm.*, vol. lxxviii, pp. 466-467. [1896.]
6786. ——— The Genesis and Chemical Relations of Petroleum and Natural Gas. *Proc. Amer. Phil. Soc.*, vol. xxxvi, pp. 93-102. [1897.]
6787. **Sadler, S. P.**, and **H. G. McCarter.** Preliminary Notice of an Investigation on "Petrocene," a Product of the Destructive Distillation of Petroleum. *Amer. Chem. Journ.*, vol. i, pp. 30-32. [1880.]
6788. **Sadler, S. S.** American Practice in the Examination of Petroleum and Petroleum Products. *Compt. Rend. Congr. internat. Chim. appl.*, sess. 5, t. i, pp. 505-507. [1904.]
6789. ——— Inner Crucible Method of determining Sulphur and Halogens in Organic Substances. *Journ. Amer. Chem. Soc.*, vol. xxvii, pp. 1188-1192. [1905.]
6790. **Saenz, N.** Contribuciones al estudio geognóstico de una seccion de la Cordillera oriental comprendida entre los 4° y 5° latitud norte del meridiano de Bogotá. 4to, Bogotá, 1878.
6791. **Safford, J. M.** Note on the Geological Position of Petroleum Reservoirs in Southern Kentucky and Tennessee. *Amer. Journ.*, ser. 2, vol. xiii, pp. 104-107. [1866.]
6792. ——— Geology of Tennessee. 8vo, Nashville, 1869.
6793. **Sagard, G.** Histoire du Canada, et Voyage des Missionnaires Récollets. 8vo, Paris, 1636.
- Sagawa, E.**, see **Kochibe, T.**
6794. **Sage, P.** L'Industrie du Naphte au Caucase. *Mém. Soc. Ing. Civ.*, 1885, vol. i, pp. 761-796.
6795. **Saint-Clair, R.** An Account of a very old Eruption of Fire out of a Spot of Earth near Frenzuola, in Italy. *Phil. Trans.*, vol. xx, p. 378. [1698.]
6796. **Saint Evre, E.** Note sur divers hydrocarbones provenant de l'hulle de schiste. *Compt. Rend.*, t. xxix, p. 339. [1849.]
6797. **Sainte-Claire-Deville, C. J.** Sur quelques produits d'émanations de la Sicile. *Compt. Rend.*, t. xii, pp. 887-894; t. xiii, pp. 359-370. [1855, 1856.]
6798. ——— Sur la composition des gaz rejetés par les évents volcaniques de l'Italie méridionale. *Ibid.*, t. xiv, pp. 398-402. [1857.]

6799. **Sainte-Claire-Deville, C. J., and F. Leblanc.** Sur les émanations gazeuses qui accompagnent l'acide borique dans les lagoni de la Toscane. *Compt. Rend.*, t. xviii, pp. 319-326. [1858.]
6800. ———. Mémoire sur la composition des gaz rejetés par les événements volcaniques de l'Italie Méridionale. *Mém. Sav. Ac. Sci. Paris*, sér. 2, t. xvi, pp. 225-276. [1862.]
6801. **Sainte-Claire-Deville, C. J., F. Leblanc, and F. Fouqué.** Sur les émanations à gaz combustibles qui se sont échappées des fissures de la lave de 1794, a Torre del Greco, lors de la dernière éruption du Vesuve. *Ibid.*, t. lvi, pp. 1185-1189. [1863.]
6802. **Sainte-Claire-Deville, H.** Lac de Bitume de la Trinité. *Proc. verb. Soc. Philom. Paris*, 1841, pp. 68-72.
6803. ———. Sur les Propriétés Physiques et le Pouvoir Calorique des Pétales et des Huiles Minérales. *Compt. Rend.*, t. lxxv, pp. 442-453; t. lxxviii, pp. 349-357, 485-502, 686-694. [1868, 1869.]
6804. ———. Emploi de l'huile de pétrole pour le chauffage des locomotives. *Ann. Sci. Ind.*, t. xiv, pp. 89-92. [1870.]
6805. ———. Sur les Propriétés Physiques et le Pouvoir Calorique de quelques Pétales de l'Empire Russe. *Compt. Rend.*, t. lxxii, pp. 191-198. [1871.]
6806. **Sainte-Claire-Deville, H., and C. Diendoné.** De l'emploi industriel des huiles minérales pour le chauffage des machines et en particulier des machines locomotives. *Ibid.*, t. lxxix, pp. 933-938. [1869.]
6807. **St. Emilian, D.** [Application of electricity in boring for Petroleum.] *Monit. Int. Pétrol. Roum.*, t. vii, pp. 509-511. [1906.]
6808. **St. John, A.** Report for the year 1896 on Peru. *Dipl. Cons. Rep.*, ann. ser., no. 1866. [1897.]
6809. **St. John, F. R.** Report for the years 1889-90 on the Trade of Servia. *Ibid.*, no. 1046. [1892.]
6810. **St. John, O.** Report on the Geology of the Wind River District. *Ann. Rep. U.S. Geol. Surv. Territ.*, vol. xii, pp. 173-269, pls. 6 maps. [1883.]
6811. **Salas, J., see Hauthal, R.**
6812. **Salas Dorjiga, J. de.** Memoria acerca de la obtencion de los aceites minerales, y extraccion de la parafina. *An. Asoc. Ingen. Ind.*, t. i, pp. 228-246. [1863.]
6813. **Salathé, F.** Résumé of Original Researches, Analyses and Refining Methods of Petroleum, mainly from the Southern Counties of California. *13th Rep. State Mineral. Calif.*, pp. 656-661. [1896.]
6814. **Salathé, F., see Waite, W. L.**
6815. **Salfeld, C. S.** Continental Gas and Oil Engine Practice. *Gas and Oil Eng. Rec.*, vol. vii, pp. 772-775, 790, 793, 804-808, 849, 853. [1908.]
6816. **Saligny, A.** [Rumanian Petroleum.] *Bull. Soc. Sci. Bucharest*, t. viii, pp. 351-365. [1899.]
6817. **Saligny, A., — Cucu, and C. I. Istrati.** Cercetari asupra pacurelor din România. *Bucharest*, 1891.
6818. **Salleron, J., and V. Urban.** Essai des huiles minérales. *Ann. Gén. Civ.* [sér. 1], t. v, pp. 154-158. [1866.]
6819. **Salomé, —.** [Iodine numbers for the light fractions of Grozni Petroleum.] *Journ. Russk. Fiz. Khim. Obsch.*, t. xxxiv, otd. 1, p. 850. [1902.]
6820. **Salomon, L.** Note sur l'emploi comparé des huiles de colza, et des huiles minérales de Pechelbronn et du Caucase, pour le graissage du matériel roulant. *Rev. Gén. Chemins de Fer*, t. viii, pt. 1, pp. 216-240; pt. 2, pp. 34-53, 224-243, pls. x, xi. [1885.]
6821. **Salomon, S. J.** [The Intchik Method of Refining Petroleum.] *Trudi Bak. Otd. Imp. Russ. Tekhn. Obsch.*, 1899.
6822. **Salomon, W.** Asphaltgänge im Quarzporphyr von Dossenheim bei Heidelberg. *Ber. oberrhein. geol. Ver.*, no. 42, pp. 116-122. [1909.]
6823. **Salpêtre, —.** Le Pétrole. *Journ. Pét.*, t. x, pp. 147-149. [1910.]
6824. **Salterain, P.** Apuntes para una Descripción fisico-química de las jurisdicciones de la Habana y Guanabacoa (Isla de Cuba). *Bol. Com. Map. Geol. Esp.*, t. vii, pp. 161-225, map. [1880.]
6825. **Salterain, P.** [Report on Mines of Asphaltum and Bituminous Oil in the Island of Cuba.] *Rep. Cons. U.S.*, vol. x, pp. 74-76. [1883.]
6826. **Salvadori, R., see Nasini, R.**
6827. **Salzer, T.** Erkennung einer Verfälschung von Oelm mit Harz oder Mineralöl. *Pharm. Centrbl.*, bd. xxxiii, p. 290. [1892.]
6828. **Salzmann, M., and H. Wichelhaus.** Ueber die Zersetzung des Braunkohlentheeröls in der Glühhitze. *Ber. deutsch. chem. Ges.*, bd. xl, p. 802. [1878.]
6829. ———. Ueber die Herstellung von Benzol aus Braunkohlentheeröl. *Ibid.*, pp. 1431-1434. [1878.]
6830. **Sammons, T.** Oil and Gas, Korea. Government Concession for Exploitation of Oil Fields. *U.S. Cons. Rep.*, no. 330, pp. 96, 97. [1908.]
6831. **Sampayo, P.** Datos Geologico-mineros de la Provincia de Burgos. *Bol. Com. Map. Geol. Espan.*, t. iii, pp. 125-132. [1876.]
6832. **Samuel, M.** Liquid Fuel. *Journ. Soc. Arts*, vol. xvii, pp. 384-393. [1899.]
6833. ———. President's Address. *Trans. Inst. Marine Eng.*, vol. xvii, pp. 235-245. [1906.]
6834. **Sandberg, C. G. S.** The Oil Prospects of Central British South Africa. *Trans. Inst. Min. Eng.*, vol. xxxv, pp. 545-558. [1908.]
6835. **Sandberger, F.** Ueber die Braunkohlenformation der Rhön. *Berg- u. Hüt. Zeit.*, bd. xxxviii, pp. 177-181, 189-191, 200-202, 209-211. [1879.]
6836. **Sanders, J. McC.** A convenient method for determining the density of heavy petroleum. *Proc. Chem. Soc.*, vol. xxvii, pp. 250-252. [1911.]
6837. **Sanderson, P.** Report for 1890-1892 on the Trade of Galatz. *Dipl. Cons. Rep.*, ann. ser., nos. 837, 996, 1170. [1891-1893.]
6838. ———. Report for 1896 on the Trade of New York. *Dipl. Cons. Rep.*, ann. ser., no. 1921. [1897.]
6839. **Sandoz-Röllin, —.** Essai statistique sur le canton de Neuchâtel. *Zurich*, 1818.
6840. **Sandwith, T. B.** Reports for 1888 on the Trade of Odessa and Batoum. *Dipl. Cons. Rep.*, ann. ser., nos. 536, 616. [1889.]
6841. **Sanford, S., see Fuller, M. L.**
6842. **Santagata, A.** De Bitumine sulphurifera. *Nov. Comment. Ac. Bologn.*, t. viii, pp. 543-552. [1846.]
6843. **Santagata, A., and D. Santagata.** Analisi del bitumi trovati nel terreno delle miniere di zolfo in Perticara, e più particolarmente di un singolare bitume solido contenente zolfo, e detto perciò solforifero. *N. Ann. Sci. Nat.*, ser. 2, vol. iv, pp. 385-398. [1845.]
6844. **Santos, J. R.** Analysis of Lamp-black made from the Natural Hydrocarbon Gas of the Ohio Petroleum. *Chem. News*, vol. xxxviii, pp. 94, 95. [1878.]
6845. **Sarasin, E., see Fuchs, E.**
6846. **Sardun, L., see Espagne, R.**
6847. **Sargent, C. E.** Tests of the Atlas Crude-Oil Engine. New Diesel-Type Engine. *Iron Age*, vol. lxxxviii, pp. 584, 585. [1911.]
6848. **Sarnow, C., see Krämer, G.**
6849. **Sasira, L.** Le Pétrole en Roumanie. *Journ. Pét.*, t. ix, pp. 82-85. [1909.]
6850. **Satow, E.** Report for 1895, 1896, on the Trade of Japan. *Dipl. Cons. Rep.*, ann. ser., nos. 1786, 1937. [1896, 1897.]
6851. **Sauerlandt, E.** Ueber das spezifische Gewicht des Paraffins aus galizischem Ozokerit von 65° bis 82° Schmelzpunkt. *Zeitschr. Paraff. Ind.*, 1878, p. 81.
6852. ———. Ueber die Erdwachs- und Petroleum-Industrie in Galizien. *Ibid.*, 1879, pp. 42, 43.
6853. ———. Die Ozokerit-Industrie mit besonderer Berücksichtigung der in den letzten Jahren gemachten Fortschritte. *Chem.-Zeit.*, bd. vii, pp. 372, 388. [1883.]
6854. **Sauerwein, A.** Emploi des pétroles Américains pour remplacer l'essence de térébenthine. *Technol.*, t. xxiv, pp. 577-580. [1863.]

6848. **Saussure, N. T. de.** Analyse du gaz oléifiant. *Ann. Chim.* t. lxxviii, pp. 57-68. [1811.]
6849. ——— Procédé pour dépouiller les pétrole de Travers, et quelques autres huiles minérales, de leur mauvaise odeur. *Bibl. Univ.*, t. vi, pp. 115-118. [1817.]
6850. ——— Recherches sur la composition et les propriétés du Naphte d'Amiano. *Ibid.*, t. iv, pp. 116-132. [1819.]
6851. ——— De l'action des huiles sur le gaz oxygène à la température atmosphérique. *Mém. Soc. Phys. Nat. Genève*, t. v, pp. 303-320. [1832.]
6852. **Sava, R.** Sul carburo d'idrogeno a Pietramala. *Riv. Bologn. Sci. Lett.*, ser. 2, vol. i, p. 407. [1869.]
6853. **Savine, P. P.** [Reverberatory Petroleum-Furnace for Foundry Purposes.] *Gorn. Journ.*, 1896, t. 2, pp. 1-12, 2 pls.
6854. ——— [Re-melting of foundry pig-iron with petroleum-residue.] *Ibid.*, 1905, t. 1, pp. 82-103.
6855. **Savulescu, J.** Une nouvelle zone de pétrole a Campina. *Mon. Int. Pétr. Roum.*, t. iii, pp. 564, 565. [1902.]
- Sawkins, J. G.**, see **Wall, G. P.**
6856. **Sawyer, A. R.** Petroleum Occurrences in the Orange River Colony. *Trans. Inst. Min. Eng.*, vol. xxx, pp. 541-544, pl. xii. [1906.]
6857. **Schaal, E.** Das Paraffin als Schutzmittel für Holz, Metalle, etc., gegen die Einwirkung von Feuchtigkeit, Säuren und Alkalien. *Gewerbebl. Würst.*, bd. xxxii, pp. 137-140. [1880.]
6858. **Schaar, G. F.** Die Steinkohlengasbereitung. Mit Anhang; die Darstellung des Leuchtgases aus Petroleumrückständen. 8vo, *Leipzic*. Ed. ii, 1880.
6859. **Schädler, C.** Die Technologie der Fette und Oele des Pflanzen- und Thierreichs. 8vo, *Leipzic*, 1883.
6860. ——— Einiges über Mineralschmieröle. *Polyt. Journ.*, bd. cxviii, pp. 230-237. [1888.]
6861. ——— Die Untersuchungen der Fette, Oele, Wacharten und der technischen Fettproducte unter Berücksichtigung der Handelsgräbche. *Leipzic*, 1890.
- Schäfer, K.**, see **Holde, D.**
6862. **Schafarik, F.** Briefliche Mittheilung aus dem Caucasus. *Földt. Közl.*, köt. xvi pp. 257-259. [1886.]
6863. ——— Ueber den Petroleumkongress zu Bucuresti und die geologischen Verhältnisse des rumänischen Petroleums. *Ibid.*, köt. xxxviii, pp. 37-56; 137-161. [1908.]
6864. **Schaffeld, A. H.** Berichte über die gesammte Petroleum-Industrie in Oelheim und Umgegend. *Peine*, 1881.
6865. **Schafhäütl, C. E.** [Gas-spring at Heilbronn.] *N. Jahrb.*, 1852, pp. 295-300.
6866. ——— Etwas über die neue *Li-pro-ine*- oder Petroleum-Gas-Lampe. *Bayr. Kunst. Gewerbe-Bl.*, bd. iii, pp. 32-37. [1866.]
6867. **Schamarin, A.** Chemische Untersuchung des Brandschiefers von Kuckers. *Arch. Nat. Lit.-Ehst.-Kurl.*, ser. 1, bd. v, pp. 25-68. [1870.]
6868. **Schander, L.** [Photogen Industry in Germany.] *St. Petersburg*, 1859.
6869. ——— [Distilling Apparatus.] *Promischl.*, 1866, no. 8, p. 16.
6870. ——— [Exploitation of Oil Springs in Central European Russia.] *St. Petersburg*, 1880.
6871. **Schapiro, —.** [Lubricants in the Vienna Exhibition.] *Selsk. Khoz. Lies*, t. 115, otd. 2, p. 43. [1874.]
6872. **Schapovitch, M. S.** [Baku and District.] 1911.
6873. **Schardt, H.** Notice sur la molasse rouge et le terrain sidérolitique du pied du Jura. *Bull. Soc. Vaud. Sci. Nat.*, t. xvi, pp. 609-640. [1880.]
6874. ——— Origine de l'asphalte dans le Jura. *Arch. Sci. Phys. Genève Nat.*, sér. 4, t. xxiii, pp. 611-614. [1907.]
6875. **Scharizer, R.** Ueber Idrialit. *Verh. k.-k. geol. Reichs.*, 1881, pp. 335-338.
6876. **Scharov, P. J.** [Position of the Baku Oil Industry in 1902.] *Gorn. Journ.*, 1903, t. 4, pp. 384-394.
6877. **Schefftel, N.** Vorkommen, Gewinnung, Uebereit. ung und Verwendung des Asphalt. *Wochenbl. Niederöstr. Gewerbe-Ver.*, bd. xlvii, pp. 405-407, 415, 416, 423-425. [1886.]
6878. **Scheibler, C.** Ueber die Bestimmung der specifischen Gewichts säthfüssiger Substanzen. *Ber. deutsch. chem. Ges.*, bd. xxiv, pp. 357, 358. [1891.]
6879. **Scheiko, B.** [Bacteriological Researches on Petroleum.] *Nepht. Dielo*, 1901, p. 402.
6880. **Scheithauer, W.** Verwerthung der Abfallschwefelsäure. *Jahresb. techn. Ver. sachs-thur. Min. Ind.*, 1888.
6881. ——— Die Fabrikation der Mineralöle und des Paraffins aus Schweißkohle, Schiefer, etc., sowie die Verstellung der Kerzen und des Oelgases. 8vo, *Brunswick*, 1895.
6882. ——— Das Bitumen der Braunkohle. *Braunkohle*. bd. iii, pp. 97-104. [1904.]
6883. ——— Oelgas. *Zeitschr. angew. Chem.*, bd. x, pp. 574-581. [1897.]
6884. ——— Ueber Verwendung von Oelgas für Gasglühlicht-Beleuchtung. *Journ. Gasbeleucht.*, bd. xiv, p. 866. [1901.]
6885. ——— Die Braunkohlenteerprodukte und das Oelgas. 8vo, *Hanover*, 1907.
6886. ——— Die Schweißteere, ihre Gewinnung und Verarbeitung. 8vo, *Leipzic*, 1911.
6887. **Schelenz, H.** Benzin and Benzol. *Zeitschr. angew. Chem.*, bd. xxi, pp. 2577-2579. [1908.]
6888. **Schelle, C. J. van.** Mededeeling over het voorkomen van aardolie bij het dorp Kolok, Padangsche Bovenlanden. *Jaarb. Mijn. Ned. O.-Ind.*, dl. v, ged. 1, pp. 188, 189. [1876.]
6889. **Schenk, E.** Tiefbohrmaschine System "Rationell." *Org. Ver. Bohrtechn.*, bd. xvii, pp. 13, 14. [1910.]
6890. **Schenk, J.** Entwicklung der Petroleumgewinnung und Bohrtechnik in Galizien (Internat. Wandvers. Bohring, u. Bohrtechn.). *Petroleum Zeitschr.*, bd. i, pp. 863, 864. [1906.]
6891. **Schenkel, J.** Ueber Petroleumprüfung. *Repert. anal. Chem.*, bd. i, p. 84. [1881.]
6892. ——— Ueber Petroleumprüfung durch fractionirte Destillation. *Chem. Ind.*, bd. vii, pp. 340, 341. [1884.]
6893. **Schepanski, I.** [Topography, Soil and Climate of Samara.] *Samarets Kalendar na 1899*, pp. 101-142. [1888.]
6894. **Schertel, —.** Der Erdgas-Ausbruch in Neuenamme bei Hamburg und seine Bewältigung. *Journ. Gasbeleucht.*, bd. liv, pp. 193-198. [1911.]
6895. **Schestakov, P. J.** [On the Nitrogen Compounds in Caucasian Naphtha.] *Journ. Russk. Fiz. Khim. Obsch.*, t. xxx, otd. 1, p. 873. [1898.]
6896. **Schestopal, —.** Das Raffiniren von Petroleum und Schmierölen und die dabei verwendeten Apparate. *Chem.-Zeit.*, bd. xv, pp. 352-354. [1891.]
- Schestopal, C.**, see **Veith, A.**
6897. **Schick, L.** [The Occurrence of Petroleum in Hungary.] *Bányász. Kohász. Lapok*, evf. xxxix, pp. 697-699. [1906.]
6898. **Schieffer, —.** Ueber das naphtaführende Terrain West Galiziens. *Vienna*, 1865.
6899. **Schiel, J.** Ueber Ozonbildung durch Kohlenwasserstoffe. *Ber. deutsch. chem. Ges.*, bd. xii, pp. 507, 508. [1879.]
6900. **Schiel, K.** Ueber Oelfeuerung im Glessereibetriebe. *Giesserei-Zeit.*, bd. viii, pp. 373-384. [1911.]
6901. **Schiele, S.** Gas aus amerikanischem Petroleum. *Journ. Gasbeleucht.*, bd. v, pp. 352, 353. [1862.]
- Schiff, —**, see **Fuchs, —.**
6902. **Schiff, H.** Zur Etymologie des Wortes "Naphta." *Chem.-Zeit.*, bd. xiv, p. 96. [1890.]
6903. **Schiff, R.** Ueber einige physikalischer Eigenschaften des Thiophens. *Ber. deutsch. chem. Ges.*, bd. xviii, pp. 1601-1605. [1885.]
6904. **Schilling, —.** Die Beleuchtung mit Gas aus Petroleum-Rückständen in der Locomotiv-Fabrik von Krauss & Co. zu München. *Journ. Gasbeleucht.*, bd. x, pp. 152-157. [1867.]

6906. **Schilling, L.** Die Fortschritte der Gasindustrie. *Zeitschr. angew. Chem.*, bd. xvii, pp. 357-363. [1904.]
6906. **Schimanovski, M.** [Petroleum in Poland.] *Gorn. Journ.*, 1886, t. 1, pp. 379-387.
6907. **Schindler, A. H.** Reisen im südwestlichen Persien. *Zeitschr. Ges. Erdk. Berlin*, bd. xiv, pp. 38-67, 81-124. [1879.]
6908. ——— Neue Angaben über die Mineralreichthümer Persiens und Notizen über die Gegend westlich von Zendjan. *Jahrb. k.-k. geol. Reichs.*, bd. xxxi, pp. 169-190, pl. II. [1881.]
6909. **Schio, A. A.** La fontana ardente di Casale (Vicenza). *Boll. mens. Osserv. centr. Moncalieri, Torino*, ser. 2, vol. xi, no. 3. [1891.]
6910. **Schleyer, W., and C. Martini.** Die Lagerung leicht entzündlicher und explosibler Flüssigkeiten. *Compt. Rend. Congr. internat. Chim. appl.*, sess. 5, t. II, pp. 383-394. [1904.]
6911. **Schlick, O.** On Signs of Weakness in Tank Steamers. *Trans. Inst. Naval Archit.*, vol. xxxviii, pp. 87-94. [1897.]
6912. **Schlüter, H.** Ueber Schmiermittel und ihre Prüfung. *Papierfabrik.*, bd. ix, pp. 1036-1040, 1061-1066. [1911.]
- Schlüter, H., see Marcusson, G.**
6913. **Schmeisser, C.** Bodenschätze und Bergbau Kleinasiens. *Zeitschr. prakt. Geol.*, bd. xiv, pp. 186-196. [1906.]
6914. **Schmeisser, J. G.** A System of Mineralogy, formed chiefly on the plan of Cronstedt. 2 vols. 8vo, London, 1795.
6915. **Schmelck, L.** Einige Untersuchungen über die jetzigen Erdöllampen. *Polyt. Journ.*, bd. cclv, pp. 39-43, 79-85. [1885.]
6916. **Schmidt, A.** Fichtelit und Reten in den Torfmooren des Fichtelgebirges. *Arch. Pharm.*, r. 3, bd. vi, pp. 538-541. [1875.]
6917. ——— Petroleumgewinnung aus dem Urstoffe. *Berg-Hütt. Jahrb.*, bd. xxx, pp. 318-326. [1882.]
6918. ——— Ueber den Fichtelit, und über Vorkommen von Dopplerit. *Centrabl. Min.*, 1901, pp. 519-525.
6919. **Schmidt, A., and A. Leonard.** The Lead and Zinc Deposits of southwest Missouri. *Rep. Geol. Surv. Missouri*, 1873-1874, pp. 389-501.
6920. **Schmidt, C.** Observations géologiques à Sumatra et Borneo. *Bull. Soc. Géol. France*, sér. 4, t. i, pp. 260-267. [1901.]
6921. ——— Ueber die Geologie von Nordwest-Borneo und eine daselbst entstandene "Neue Insel." *Beitr. Geophys.*, bd. vii, pp. 121-136, maps and sections. [1904.]
6922. ——— Notiz über das geologische Profil durch die Oelfelder bei Boryslaw in Galizien. *Verh. Naturf. Ges. Basel*, bd. xv, pp. 415-424, pl. vii. [1904.]
6923. ——— Montanindustrie. *Handwörterbuch Schweiz. Volkswirtsch.*, bd. iii, 1907.
6924. **Schmidt, C. (2).** Geologisches Gutachten über das Vorkommen von Naturgasen und Erdöl in der Umgebung von Baaszen bei Mediasch in Siebenbürgen. *Ung. Montanind. Zeit.*, 1900.
6925. **Schmidt, C. F. E.** Die Erdöl-Reichthümer Galiziens. Eine technologisch-volkswirtschaftliche Studie. *Vienna*, 1865.
6926. ——— Das Erdöl Galiziens, dessen Vorkommen und Gewinnung, nebst fachwissenschaftlichen Beiträgen zur fabrikmässigen Darstellung seiner Producte. *Hamburg*, 1866.
6927. **Schmidt, C. H.** Die neuesten Beleuchtungstoffe. *Weinar. Ed. II*, 1861.
6928. **Schmidt, E.** Ueber einen neuen dem Anthracen isomeren Kohlenwasserstoff. *Ber. deutsch. chem. Ges.*, bd. v, pp. 930-933. [1872.]
6929. ——— Beiträge zur Kenntniss des Anthracens und Chrysens. *Journ. prakt. Chem.*, bd. cxvii, pp. 241-289. [1874.]
6930. **Schmidt, F.** Dei Fichtelit in den Torfmooren des Fichtelgebirges. *Korr.-Bl. zool.-min. Ver. Regensburg*, bd. xvi, pp. 180, 181. [1862.]
6931. **Schmidt, Fried.** On the Silurian (and Cambrian) Strata of the Baltic Provinces of Russia, as compared with those of Scandinavia and the British Isles. *Quart. Journ. Geol. Soc.*, vol. xxxviii, pp. 514-536, pl. xxiii. [1882.]
6932. **Schmidt, F.** [Evolution of Hydrocarbon Gas from artesian boring on Kokschar I., Esthonia.] *Verh. Russ. k. Min. Ges.*, bd. xli, Protok., pp. 43-45. [1903.]
6933. **Schmidt, G.** Abriss der Petroleumgeologie Rumäniens. *Berlin and Vienna*, 1911.
6934. **Schmidt, S.** Erdölschlürfungen im Marmaroscher Komitat. *Allg. österr. Chem.-Techn.-Zeit.*, bd. xix. 1902.
6935. **Schmidt, V.** [Photogen Industry in Germany.] *Promischl.*, 1859, no. 11, otd. 3, pp. 23-64.
6936. **Schmitz, E. J.** The Oil Boom of Tennessee. *Eng. Min. Journ.*, vol. lxi, pp. 228, 229, map. [1896.]
- Schneider, C., see Engler, C.**
6937. **Schneider, C. F. A.** Geologische Uebersicht über den holländisch-östindischen Archipel. *Jahrb. k.-k. geol. Reichs.*, bd. xxvi, pp. 113-134, pls. v, vi. [1876.]
6938. **Schneider, O.** Ueber das Vorkommen des Asphaltes und Schwefels im Becken des todtten Meeres. *Gaea*, bd. viii. [1872.]
6939. ——— Naturwissenschaftliche Beiträge zur Geographie und Kulturgeschichte der Kaukasusländer. 8vo, Dresden, 1883.
6940. ——— Kaukasische Naphtaproduction. *Dresden*, 1887.
6941. ——— Die Schwefelminen am Ras el Gemse. 8vo, Dresden, 1887.
6942. **Schober, G.** Dissertatio medica, de Mumia Persica, i. e. remedio in Asia celeberrimo. . . . *Act. phys.-med. Acad. Leop.-Car. Nat. Cur.*, vol. i, pp. 160-157. [1727.]
6943. **Schober, G. (2).** Die Tiefbohrtechnik im Dienste der Geologie. *Org. Ver. Bohrtechn.*, bd. xvii, pp. 37-39, 76, 77, 89-91, 101-103, 114, 115, 126, 127, 138, 139, 162, 163. [1910.]
6944. **Schöller, P. v.** Report for 1893 and 1895 on the Trade of Austria-Hungary. *Dipl. Cons. Rep.*, ann. ser., nos. 1387, 1777. [1894, 1896.]
6945. **Schöndorf, F.** Die deutsche Tiefbohrgesellschaft und die Erschliessung der eisässischen Erdölterrains. *Org. Ver. Bohrtechn.*, bd. xvii, p. 281. [1910.]
6946. **Schöndorf, Fr.** Geologische Exkursion nach den Asphaltgruben bei Ahlem. *Asphalt-Teerind.-Zeit.*, bd. x, pp. 661, 662. [1910.]
- Schöne, G., see Mylius, F.**
6947. **Schönwald, H.** Ausländischen und deutscher Stampfasphalt. *Asphalt-Teerind.-Zeit.*, bd. v, pp. 221, 222, 237, 238. [1905.]
6948. **Schöpfing, J. D.** Alsatia Illustrata. 2 Tt. Fo, Colmar, 1751, 1761.
- Schöttler, R., see Hartmann, W.**
6949. **Schomburgk, R. H.** The History of Barbadoes, comprising a Geographical and Statistical Description of the Island, a sketch of the Historical Events since the Settlement, and an Account of its Geology and Natural Productions. 8vo, London, 1848.
6950. **Schooley, J. S.** Petroleum Region of America. *Harper's Mag.*, vol. xxx, p. 562. [1865.]
6951. **Schorlemmer, C.** On the Derivatives of Hydride of Heptyl. *Journ. Chem. Soc.*, vol. xvi, pp. 216-221. [1863.]
6952. ——— On the Chemical Constitution of American Rock Oil. *Proc. Lit. Phil. Soc. Manch.*, vol. iii, pp. 81-85. [1863.]
6953. ——— Researches on the Hydrocarbons of the Series  $C_nH_{2n+2}$ . *Proc. Roy. Soc.*, vol. xiv, pp. 164-176, 464-470; vol. xvi, pp. 34-39, 367-376; vol. xviii, pp. 25-29; vol. xix, pp. 20-22, 487, 488. [1865, 1868, 1870, 1871.]
6954. ——— Notiz über Americanisches Steinöl. *Zeitschr. Chem.*, bd. i, pp. 242, 243. [1865.]
6955. ——— Note on the Amyl-compounds derived from Petroleum. *Proc. Roy. Soc.*, vol. xv, pp. 131-136. [1867.]

6956. **Schorlemmer, C.** On the Boiling Points of the Normal Paraffins, and some of their Derivatives. *Proc. Lit. Phil. Soc. Manch.*, vol. xi, pp. 95-98. [1872.]
6957. ——— The Chemistry of the Hydrocarbons. *Journ. Chem. Soc.*, vol. xxv, pp. 425-446. [1873.]
6958. ——— On the Heptanes from Petroleum. *Ibid.*, vol. xxvi, pp. 319-323. [1873.]
6959. ——— Some Remarks on the Preceding Paper [5391]. *Ibid.*, vol. xxviii, pp. 306, 307. [1875.]
6960. ——— On the Normal Paraffins. *Phil. Trans.*, vol. cxlii, pp. 111-123; vol. cxlxi, pp. 49-53; vol. cxlxi, pp. 461-464. [1872, 1878, 1881.]
6961. **Schorlemmer, C.**, and **T. E. Thorpe.** On the Normal Paraffins. Part IV. *Phil. Trans.*, vol. cxlxiv, pp. 269-271. [1884.]
6962. **Schorrig, E.** Neuere Theorie über die Entstehung des Petroleum. *Petroleum Zeitschr.*, bd. ii, pp. 41-43. [1906.]
6963. **Schostkovski, I.** [Oil Industry of Baku in 1904.] *Gorn. Journ.*, 1906, t. 2, pp. 130-140.
6964. **Schottky, A.** Ueber die Methoden der Prüfung des Petroleum und die dazu verwendeten Apparate. *Chem.-Zeit.*, bd. liii, pp. 193, 205. [1879.]
6965. **Schpadi, I. B.**, and **V. Markovnikov.** [Investigations on Caucasian Petroleum. On the Chemical Properties of Naphtha.] *Journ. Russk. Khim. Obsch.*, t. xix, pp. 516-520. [1887.]
6966. ——— Zur Constitution der Kohlenwasserstoffe,  $C_nH_{2n}$ , des Kaukasischen Petroleum. *Ber. deutsch. chem. Ges.*, bd. xx, pp. 1850-1853. [1887.]
6967. **Schuckovskii, —** [Comparative Value for Steamboilers, of Coal, Turpentine and Petroleum.] *Morsk. Sborn.*, 1866, pp. 173-180.
6968. **Schrader, F. C.** A Reconnaissance of a part of Prince William Sound, and the Copper River District, Alaska, in 1898. *20th Ann. Rep. U.S. Geol. Surv.*, pt. vii, pp. 341-423, pls. xxii-xxxv. [1900.]
6969. ——— Independence, Kans. Fo. 159, *U.S. Geol. Surv.*, 1908.
6970. **Schrader, F. C.**, and **E. Haworth.** Oil and Gas in the Independence Quadrangle, Kansas. *Bull. U.S. Geol. Surv.*, no. 260, pp. 446-458. [1903.]
6971. ——— Economic Geology of the Independence Quadrangle, Kansas. *Bull. U.S. Geol. Surv.*, no. 296. Pp. 74; 6 pls. [1906.]
6972. **Schreiber, F.** Das Verhalten hochsiedender Mineralöle bei der Erhitzung im Luft- und Dampfström. *Zeitschr. angew. Chem.*, bd. xxiii, pp. 99-103. [1910.]
6973. **Schreiber, K.** Ueber den Fettreichtum der Abwasser und das Verhalten des Fettes im Boden der Riesel-feldern Berlins. *Arch. Hygiene*, bd. xiv, pp. 295-353. [1902.]
6974. **Schréter, Z.** Geologische Exkursion in die Umgebung von Nograd und Szokolajahuta. *Földt. Köz.*, köt. xi, pp. 373-376, 447-451. [1910.]
6975. **Schröckenstein, F.** [Geological Structure of the Banat Mining District.] *Mag. Földt. Tars. Munkal.*, köt. v. 1870.
6976. **Schröder, J. T.** [On Bakelite, Oxidised Petroleum of L. Baikal.] *Verh. k. russ. min. Ges.*, ser. 2, bd. xxxv, pp. 36, 37. [1893.]
6977. **Schröter, M.** Diesels rationeller Wärmemotor. *Zeitschr. Ver. deutsch. Ing.*, bd. xli, pp. 845-852. [1897.]
6978. **Schröter, L. P.** Beschreibung des asphaltischen kalten Schwefelquellen zu Nenndorf. *Rinteln*, 1788.
6979. ——— Das neueste von den asphaltischen Schwefelquellen zu Nenndorf. *Rinteln*, 1790.
6980. ——— Nenndorf's asphaltische Schwefelquellen, historisch, physikalisch-chemisch, und medicinisch beschrieben. *Rinteln*, 1790.
6981. **Schrötter, A.** Ueber das Idralin. *Zeitschr. Phys. Math. Wiss.*, f. 2, bd. lii, pp. 245-247. [1835.]
6982. ——— Ueber das Brandenz aus Idrin. *Ibid.*, bd. iv, pp. 5-23. [1836.]
6983. ——— [Ozokerite.] *Ibid.*, pp. 173-176. [1836.]
6984. **Schrötter, A.** Ueber das Idralin und ein Erdharz. *Ber. deutsch. Nat. Versamml.*, 1837, p. 117.
6985. ——— Ueber ein eigentümliches Erdharz das in Ungarn als Wagenschmiere benutzt wird. *Ibid.*, pp. 117, 118.
6986. ——— Ueber mehrere in Braunkohlen- und Torflagern vorkommende neue harzige Substanzen, und deren Verhältniss zu einigen Harzen noch lebender Pflanzen. *Ann Phys Chem.*, bd. lix, pp. 37-76. [1843.]
6987. **Schubarth, E. O.** Ueber Asphalt-Strassen. 8vo, Berlin, 1881.
6988. ——— Ueber Asphalt und Asphalt-Strassen. 8vo, Munich, 1888.
6989. **Schubeler, F.** Modern Diesel Oil Engines. *Electrician*, vol. lxxvii, pp. 662, 663. [1911.]
6990. **Schubert, C. J.** Ueber das Vorkommen des Ozokerits (Bergwachses) und der ihm verwandten Mineralien und deren Gewinnung in Galizien. *Berg-Hütt. Jahrb.*, bd. xiii, pp. 167-173. [1864.]
6991. **Schubert, R.** Die nutzbaren Mineralergasterstätten Dalmatiens. *Zeitschr. prakt. Geol.*, bd. xvi, pp. 49-56. [1908.]
6992. **Schürmann, J.** Die Petroleumlagerstätte. *Deutsche Bergwerks-Zeit.*, 1910.
6993. **Schützenberger, P.**, and **N. Jonina.** Sur la Composition du Pétrole du Caucase. *Compt. Rend.*, t. xci, pp. 823-825. [1880.]
6994. **Schukov, A. A.** Ueber eine neue Methode zur Bestimmung der Erstarrungstemperaturen. *Zeitschr. angew. Chem.*, bd. xii, pp. 563, 564. [1899.]
6995. ——— Die Bestimmung der Erstarrungstemperaturen von Fettkörpern und Paraffin. *Compt. Rend. Congr. internat. Chim. appl.*, sess. 5, t. li, pp. 624, 625. [1904.]
6996. ——— Zur Bestimmung des Erstarrungspunktes des Handelsparaffines. *Chem. Rev. Fett-Harz-Ind.*, bd. xv, p. 112. [1908.]
6997. **Sohnkov, A. A.**, and **N. S. Pantjukhov.** [Paraffin in Russian Petroleum.] *Viestn. Jivov. Veschestv.*, 1899.
6998. **Sohnkov, V.**, and **S. Gavrilov.** Vorrichtungen zu ununterbrochenen fractionirten Destillation von Rohöl und ähnlichen Flüssigkeiten, wie auch zur Erzeugung von Gas aus Erdöl und seinen Derivaten. *Zeitschr. angew. Chem.*, bd. vi, pp. 230, 231. [1893.]
6999. **Schulz, —** Die Oelvorkommen in Argentinien. *Petroleum Zeitschr.*, bd. iv, pp. 805, 806. [1909.]
7000. **Schulz, A. R.** The Labarge Oil Field, Central Uinta County, Wyoming. *Bull. U.S. Geol. Surv.*, no. 340, pp. 364-373, pl. iv. [1905.]
7001. ——— Geography and Geology of part of Uinta County, Wyo. *Ibid.*, no. [191.]
7002. **Schultz, G.**, and **K. Würth.** Ueber Oelgasteer aus Braunkohlenteeröl. *Journ. Gasbeleucht.*, bd. xlviii, pp. 125-131, 152-158, 200-203. [1905.]
7003. **Schultz, G. T. A. O.** Investigation of Roumanian Petroleum. *Petrol. Rev.*, vol. vi, pp. 593-598. [1902.]
7004. **Schultz, H.** Oil Barrel Truck Power, vol. xxix, p. 320. [1908.]
7005. **Schulz, F.** Eine neue Reaktion der Mineralöle. *Chem.-Zeit.*, bd. xxxii, p. 345. [1908.]
7006. ——— Ueber den Säuregehalt der galizischen Rohöle. *Ibid.*, p. 596. [1908.]
7007. ——— Petrolsäuren oder Naphthensäuren. *Ibid.*, p. 772. [1908.]
7008. ——— Die Englische Zahl der Oelgemische. *Chem. Rev. Fett-Harz-Ind.*, bd. xvi, pp. 297-299. [1909.]
7009. ——— Die trockene Refinement der Mineralöle. *Petroleum Zeitschr.*, bd. v, pp. 86-90. [1909.]
7010. ——— Untersuchungen über den Refinationsvorgang. *Ibid.*, pp. 205-207; 446-449, 1242, 1243. [1909, 1910.]
7011. ——— Zur Charakteristik der künstlichen Erdöle. *Ibid.*, bd. vi, pp. 657, 658. [1911.]
7012. ——— Ueber den Einfluss von Selen bei der Refinement der Mineralöle. *Chem.-Zeit.*, bd. xxxv, pp. 1129, 1130. [1911.]

7013. **Schulze, F.** Einwirkung des Schwefels auf Benzol. *Ber. deutsch. chem. Ges.*, bd iv, pp. 33, 34. [1871.]
7014. **Schumacher, —.** Strassburg und seine Bauten. *Strassburg*, 1894.
7015. **Schur, F.** Ueber das Vorkommen des brennbaren Gases bei Kis-Saros [Siebenbürgen]. *Verh. Siebenb. Ver. Nat.*, bd. v, p. 206. [1855.]
7016. — Bericht über eine botanische Rundreise durch Siebenbürgen [Vorkommen des brennbaren Gases bei Kis-Saros, p. 206.] *Verh. Siebenb. nat. Ver.*, bd. x, pp. 58–86, 96–212. [1859.]
7017. **Schuster, —.** Untersuchung der Erdölquellen im Lüneburg'schen. *Mith. Gewerbe-Ver. Hannover*, 1840–1841, pp. 116–119. [1841.]
7018. **Schuster, M.** Ueber ein neues Vorkommen von krystallisiertem Fichtelit. *Min. petr. Mith.*, bd. vii, pp. 88, 89. [1885.]
7019. **Schuyler, J. D.** The Use of Asphaltum for Reservoir Linings. *Trans. Amer. Soc. Civ. Eng.*, vol. xxvii, pp. 629–639; vol. xxviii, pp. 130–143. [1892, 1893.]
7020. **Schwager, A., and C. W. v. Gümbel.** Mittheilungen aus dem chemischen Laboratorium der geognostischen Abtheilung des königl. Oberbergamtes. *Geogn. Jahresh. Münch.*, bd. vii, pp. 57–94. [1894.]
- Schwarz, —, see Holde, D.**
7021. **Schwarz, B.** Montenegro. Schilderung einer Reise durch das Innere nebst Entwurf einer Geographie des Landes. 8vo, *Leipzig*, 1883.
7022. **Schwarz, C.** Ueber die Gewinnung des Benzins, Petroleums, Paraffins und Schmieröles aus dem Rohpetroleum. *Zeitschr. angew. Chem.*, bd. xiv, p. 632. [1901.]
7023. **Schwarz, F., and J. Marcusson.** Prüfung von Mineralöl auf Gegenwart von fettem Öl. *Mith. k. Mat.-prüf.-Amt.*, bd. xxvii, pp. 17–19. [1909.]
7024. **Schwarz, H.** Die Beleuchtung der sogenannten Hydro-Oxygenas-Mikroskope. Ersatz des Wasserstoffs durch Photogen. *Bresl. Gewerbebl.*, bd. vi, p. 16. [1860.]
7025. — Eröl, Naphta, und Photogen Betreffendes. *Oesterr. Zeitschr. Berg-Hütt.*, bd. viii, p. 172. [1860.]
7026. — Die Produkte der trockenen Destillation auf der Wiener Weltausstellung, 1873. *Polyt. Journ.*, bd. cxx, pp. 205–215. [1873.]
7027. — Ueber die Zusammensetzung des Pyropissits. *Ibid.*, bd. ccxxxii, pp. 465–476. [1879.]
7028. **Schwarz, J.** [Petroleum Reservoir on the Kaiser Ferdinand's Nord Bahn, Vienna.] *Zeitschr. Oesterr. Ing. Archiv. Ver.*, bd. xviii, p. 168. [1866.]
7029. **Schwarz, P.** Der zweite internationale Petroleumkongress. *Chem. Rev. Fett-Harz-Ind.*, bd. xii, pp. 216, 217, 239–241. [1905.]
7030. — Die Beteiligung deutschen Kapitals an der galizischen Erdölindustrie. 8vo, *Berlin*, 1907.
7031. — Festschrift für den dritten internationalen Petroleumkongress (Bukarest, Sept. 1907). *Berlin*, 1907.
7032. — Mittel zur Erhöhung der Leuchtkraft des Petroleums. *Seifensied.-Zeit.*, bd. xxxiv, pp. 549, 550, 569, 570. [1907.]
7033. — Ein Reichspetroleummonopol. *Berlin*, 1908.
7034. — Der Oesterreichisch Volkswirtschaft. *Vienna*, 1909.
7035. — Die Kapitalinvestitionen in der rumänischen Petroleum-Industrie in ihrer geschichtlichen Entwicklung. *Compt. Rend. Congr. internat. Pétrole*, sess. 3, t. ii, pp. 823–846. [1910.]
- Schwarz, P., see Mendel, J.**
7036. **Schwede, I. P.** [Friction of Oil in Iron Pipes.] *Zap. Kav. Otd. Imp. Russk. Tekhn. Obsch.*, t. xii, pp. 129–143 [1880.]
7037. **Schweder, G.** Ueber Schlammvulkane und Inselbildung im Kaukasus und Kaspsee. *Korr.-Blatt. Nat. Ver. Riga*, bd. xxxvi, pp. 41, 42. [1893.]
7038. — Gasausströmung aus einem artesischen Brunnen [in Riga]. *Ibid.*, bd. xxxix, p. 83. [1896.]
- Schwedhelm, H., see Künkler, A.**
7039. **Schweinfurth, G.** Ein Besuch bei den Schwefelminen und Petroleum-Quellen von Gimsah an der Aegyptischen Küste des Rothen Meeres. *Zeitschr. Erdk. Berlin*, bd. iii, pp. 521–527. [1868.]
7040. — The Petroleum Wells of the Red Sea Coast of Egypt. *Athenaeum*, no. 3087, p. 865. [1886.]
7041. **Schweitzer, J. P.** A Lecture on Petroleum. *Missouri University Lectures*, Course II, vol. 1. 8vo, *Columbia, Mo.*, 1879.
7042. **Schwenke, R.** Ueber Ceresine. *Chem.-Zeit.*, bd. viii, pp. 1820, 1821. [1884.]
7043. **Scott, H. C.** A Note on Mining in Siam. *Min. Journ.*, vol. lxxvi, p. 185. [1904.]
7044. **Scoullar, G.** The Geology of the Neighbourhood of Gawler. *Proc. Roy. Soc. S. Australia*, vol. v, pp. 57–72, pl. ii. [1882.]
7045. **Scovell, J. T.** Geology of Vigo County, Indiana. *Ann. Rep. Geol. Indiana*, vol. xxi, pp. 507–576. [1897.]
7046. **Scrope, G. P.** Volcanoes: the Character of their Phenomena, their share in the Structure and Composition of the Surface of the Globe, and their Relation to its Internal Forces. 8vo, *London*, 1862.
7047. **Seager, J. A.** Oil Engines for Driving Gravity Stamps. *Eng. Min. Journ.*, vol. xcii, pp. 851, 852. [1911.]
7048. **Seal, A. N.** Utah Ozokerite. *Journ. Frankl. Inst.*, vol. cxxx, pp. 402–406. [1890.]
7049. **Sedna, L.** Das Wachs und seine technische Verwendung. *Vienna*, 1886.
7050. **Seetzen, U. J.** A Brief Account of the Countries adjoining the Lake of Tiberias, the Jordan, and the Dead Sea. 4to, *Bath*, 1810.
7051. **Segil, S.** Die österreichische Petroleumindustrie in Gefahr. *Allgem. österr. Chem.-Techn.-Zeit.*, bd. xxvi, pp. 66, 67. [1908.]
7052. **Segrave, W. F.** Report for 1888 on the Trade of Baltimore. *Dipl. Cons. Rep.*, ann. ser., no. 463. [1889.]
7053. **Seidlitz, N.** Ausbruch des Schlammvulkans Lokbotan bei der transkaukasischen Eisenbahnstation Puta. *Das Ausland*, bd. ix, pp. 167–169. [1887.]
- Seidner, S., see Engler, C.; and Kast, H.**
7054. **Seifert, —.** Die Erdwach- und Petroleum-Industrie Boryslaws. *Zeitschr. Berg-, Hütt.-Salinenw.*, bd. xlix, pp. 87–96. [1901.]
- Sell, E., see Blanchet, R.**
- Sellards, E. H., see Haworth, E.**
7055. **Selligie, —.** Emploi de l'huile extraite des schistes bitumineux pour la fabrication du gaz d'éclairage. *Compt. Rend.*, t. iv, pp. 968, 970. [1837.]
7056. — Emploi de l'huile provenant de la distillation des schistes bitumineux pour le traitement de la gale. *Ibid.*, t. ix, pp. 140, 141. [1839.]
7057. — Procédé pour la fabrication d'un gaz d'éclairage au moyen des huiles provenant de la distillation de certains schistes bitumineux. *Compt. Rend.*, t. x, pp. 861–865. [1840.]
7058. **Sello, —.** Ueber Selböhren, nach Art der Chinesen. *Arch. Min. Geogn.*, bd. vi, pp. 343–369. [1833.]
7059. — Ueber das Abbohren weiter Bohrer mit dem Selböhren. *Ibid.*, bd. vii, pp. 526–533; bd. ix, pp. 377–404. [1834, 1836.]
7060. **Selwyn, A. R. C.** Summary Reports on the Operations of the Geological Survey for the years 1884–1891. *Ann. Rep. Geol. Surv. Canada*, n.s., vols. l–v, reports A and AA. [1886–1893.]
7061. — Descriptive Catalogue of a Collection of the Economic Minerals of Canada (Colonial and Indian Exhibition). 8vo, *London*, 1886.
7062. **Selwyn, J. H.** Petroleum as Steam Fuel. *Journ. Roy. United Serv. Inst.*, vol. ix, pp. 62–70. [1865.]
7063. — Further Information on the Employment of Mineral Oils as Fuel for Steamships. *Ibid.*, vol. xii, pp. 28–43, pl. ii. [1868.]
7064. — On Liquid Fuel. *Trans. Inst. Naval Arch.*, vol. ix, pp. 88–103. [1868.]



7065. Selwyn, J. H. On the Progress of Liquid Fuel. *Trans. Inst. Naval Arch.*, vol. x, pp. 32-46. [1869.]
7066. ——— On Liquid or Concentrated Fuel. *Ibid.*, vol. xi, pp. 160-174. [1870.]
7067. ——— Petroleum as Fuel. *Engl. Mech.*, vol. xxiv, p. 316. [1876.]
7068. ——— On Liquid Fuel for Marine Purposes. *Journ. Roy. United Serv. Inst.*, vol. xxix, pp. 689-701. [1885.]
7069. Semenov, P. [Kerosene at the Present and in the Future.] *Zap. Imp. Russk. Tekhn. Obsch.*, g. xxvii, July-Aug., pp. 1-24, 1 pl. [1893.]
7070. Semenov, P. [Analysis of the Gases of the Surakhani Oil-spring and of the Bulganak Mud-volcano.] *Varsavsk. Univ. Izv.*, 1888, no. 4, pp. 1-6.
7071. Semetkovski, F. v. Gas-Exhalation nachst Kezdly-Vasarhely. *Verh. Siebenb. Ver. Nat.*, bd. xv, pp. 69, 70. [1864.]
7072. Semiannikov, — [Lok Botan Mud-volcano, Puta.] *Gorn. Journ.*, 1887, t. 1, pp. 185-187.
7073. Seminario, P. I., and F. O. Lopez. El Petroleo en Paiza. *Bol. Ministr. Fom. Peru*, t. i, no. 2, pp. 16-19. [1903.]
7074. Semmola, E. Le Fiammenel Cratere del Vesuvio in Aprile 1898. *Rend. R. Acc. Sci. Napoli*, ser. 3, t. iv, pp. 215-219. [1898.]
- Senderens, J. B., see Haller, A., and Sabatier, P.
7075. Serres, P. M. T. de. Considérations générales sur la Minéralogie du Département de l'Hérault. *Journ. Mines*, t. xxiv, pp. 231-236. [1808.]
7076. Servier, E. Eclairage au Gaz, à l'Hulle, au Pétrole, etc. Études sur l'Exposition de 1878. Pt. 2, t. iv.
7077. Setz, H. R. Oil Engines. *Journ. Amer. Soc. Mech. Eng.*, vol. xxxiii, pp. 1167-1200. [1911.]
7078. Sevastos, R. [The Glodeni Oil-fields.] *Monit. Int. Pétrol. Roum.*, t. ii, pp. 500-504. [1901.]
7079. Severin, Basil. [Attempt at a Mineralogical Account of Russia.] 1809.
- Severin, E., see Hviid, N.
7080. Sewerign, W. Untersuchung über einen Erdbrand oder den Rauchenden Berg unweit Reval. *Ann. Phys.*, bd. xxvii, pp. 342-345. [1808.]
7081. Seymour, A. T. Map of the Oilfields of Central Wyoming. *Florence, Wis.*
7082. Seyrig, W. L'Emploi du Pétrole comme combustible à l'Exposition de Chicago. *Gén. Civ.*, t. xxiv, pp. 216, 217. [1894.]
7083. Sgarzi, G. Sulla materia concreta . . . delle acque termale della Porretta; sul gas infiammabil che si svolge dalle medesime acque. e dal monte Porretano e sulla temperatura delle dette terme. *Nuovi Ann. Sci. Nat.*, t. i, pp. 161-189, 220-245. [1838.]
- Shaler, M. K., see Taft, J. A.
7084. Shaler, N. S. Conditions and Effects of the Expulsion of Gases from the Earth. *Proc. Boston Soc. Nat. Hist.*, vol. xxvii, pp. 89-106. [1896.]
7085. Sharp, P. The Poisonous Effects of Petroleum. *Med. News*, Aug. 1888, p. 150.
7086. Shattuck, C. H. [Coal Oil of West Virginia.] *Rep. Comm. Agric. W. Virginia*, 1863, p. 525.
7087. Shaw, E. W., and M. J. Munn. Coal, Oil and Gas of the Foxburg Quadrangle, Pennsylvania. *Bull. U. S. Geol. Surv.*, no. 454. Pp. 85; 10 pls. [1911.]
7088. Shaw, Thomas. Travels and Observations relating to Several Parts of Barbary and the Levant. *Fo, Oxford*, 1738.
- Sheafer, A. W., see Ashburner, C. A.
7089. Sheedy, P. The Use of Oil Fuel on the Southern Pacific [Railroad.] *Amer. Eng. R.R. Journ.*, vol. lxxv, pp. 207-209. [1902.]
- Shelbourn, E. T., see Coste, J. H.
7090. Shelby, C. F. Oil Burners for Reverberatory Furnaces. *Eng. Min. Journ.*, vol. lxxxix, pp. 31, 32. [1910.]
7091. Shepard, C. N. A Report on the Geological Survey of Connecticut. 8vo, *Newhaven*, 1837.
7092. Sherman, H. C., T. T. Gray, and H. A. Hammerschlag. A comparison of the calculated and determined viscosity numbers (Engler), and flashing and burning points in oil mixtures. *Journ. Ind. Eng. Chem.*, vol. 1, pp. 13-17. [1909.]
7093. Sherman, H. C., and A. H. Kropff. The Calorific Power of Petroleum Oils and the Relation of Density to Calorific Power. *Journ. Amer. Chem. Soc.*, vol. xxx, pp. 1626-1631. [1908.]
7094. Sherman, H. C., and J. F. Snell. On the Heat of Combustion as a Factor in the Analytical Examination of Oils; and the Heats of Combustion of some Commercial Oils. *Ibid.*, vol. xxiii, pp. 164-172. [1901.]
7095. Sherrill, C. H. Petroleum Industry, Argentina. Petroleum Residues as Fuel. *U. S. Cons. Rep.*, no. 357, p. 197. [1910.]
7096. Sherwood, A., and F. Platt. The Geology of Potter County. 2nd Geol. Surv. Penns., G 3. 8vo, *Harrisburg*, 1881.
7097. Sherwood, J. D. Some Observations upon the Valley of the Jordan and the Dead Sea. *Amer. Journ.*, vol. xlviii, pp. 1-16. [1844.]
7098. Shinn, W. P. Pittsburgh, its Resources and Surroundings. 1880.
7099. Shirley, Thos. The Description of a Well and Earth in Lancashire taking fire by a Candle approached to it. *Phil. Trans.*, vol. ii, p. 482. [1667.]
7100. Short, Dr. T. The Natural Experimental and Medicinal History of the Mineral Waters of Derbyshire, Lincolnshire and Yorkshire. 4to, *London*, 1734.
7101. Shufeldt, G. A., jun. On an Oil-well Boring at Chicago. *Amer. Journ.*, ser. 2, vol. xl, pp. 388, 389. [1865.]
7102. Shufeldt, R. W. Reports of Explorations and Surveys to ascertain the practicability of a Ship-canal between the Atlantic and Pacific Oceans by the way of the Isthmus of Tehuantepec. 4to, *Washington*, 1872.
7103. Shumard, B. F. Oil Springs in Missouri. *Trans. Ac. Sci. St. Louis*, vol. ii, pp. 263, 264. [1866.]
7104. Sickenberger, E. Zur Entstehung des Erdöls. *Chem.-Zeit.*, bd. xv, pp. 1582, 1583. [1891.]
7105. Siebenthal, C. E. Mineral Resources of North-eastern Oklahoma. *Bull. U. S. Geol. Surv.*, no. 340, pp. 187-228; pl. ii. [1908.]
- Siebenthal, C. E., see Darton, N. H.; and Smith, N. S. T.
7106. Sigmeth, K. Ausflug in die Marmaros. Die Petroleumquellen von Dragomer. *Jahrb. ung. Karp.-Ver.*, 1878.
7107. ——— Ausflug in die Unger Karpathen. *Ibid.*, 1878.
7108. ——— Reiseskizzen aus der Marmaros. *Ibid.*, 1881, p. 125.
7109. Siemaschko, I. [A Type of Burner for Solar Oil.] *Zap. Imp. Russk. Tekhn. Obsch.* g. xxviii, Sept.; Trudi, pp. 24-32, pl. [1894.]
7110. Siemens, G. R. v. Mannesmann-Rohrleitung von 100 at. Betriebsdruck für flüssige Brennstoff im Ural. *Sitz. Ver. Beförd. Gewerbest.*, bd. lxx, pp. 172, 173. [1891.]
7111. Siemetchkin, L. P. [On Russian Petroleum Lubricants, prepared by the Method of Engineer N. A. Sokhanski.] *Zap. Imp. Russk. Tekhn. Obsch.* g. vi, otd. i, pp. 11-19. [1872.]
7112. Sieplein, O. J., see Mabery, C. F.
7113. Sievers, W. Ein Schlammvulkan, Hervidero, in der Llanos von Maturin. *Deutsche Rundschau Geogr.*, bd. xx, pp. 394-398. [1898.]
7114. Sievertzev, — [Geological Observations in the Western Part of the Kirgiz Steppe in 1857.] *Gorn. Journ.*, 1860, t. 2, pp. 301-318.
7115. Siewert, M. Ueber einen im Solaröl enthaltenen crystallisirbaren Kohlenwasserstoff. *Zeitschr. ges. Nat.*, bd. xxiv, pp. 396-399. [1864.]
7116. ——— Untersuchungen einiger Rohpetroleum-vorkommen und Brennmaterialien in der Argentinischen Republik. *Monatsb. k. preuss. Ak. Wiss.*, bd. v, pp. 224-227. [1872.]

- Silbermann, J. T., see Favre, P. A.
7116. **Silliman, B., sen.** Notice of a Fountain of Petroleum called the Oil-spring [Allegany Co., N. York]. *Amer. Journ.*, ser. 1, vol. xxiii, pp. 97-103. [1833.]
7117. **Silliman, B., jun.** Report on the Rock Oil or Petroleum from Venango County, Pennsylvania, with special reference to its use for illuminating and other purposes. Privately, *Newhaven*, 1855. *Amer. Chem.*, vol. ii, pp. 18-23. [1871.]
7118. — Oil-wells of Pennsylvania and Ohio. *Amer. Journ.*, ser. 2, vol. xxx, pp. 305, 306. [1860.]
7119. — A Description of the recently discovered Petroleum Region of California, with a Report of the same. *New York*, 1865.
7120. — Examination of Petroleum from California. *Amer. Journ.*, ser. 2, vol. xxxix, pp. 341-343. [1865.]
7121. — On Naphtha and Illuminating Oil from heavy California Tar (Maitha), and on the probable Origin of Petroleum. *Ibid.*, vol. xliii, pp. 242-246. [1867.]
7122. — Note on Wollongongite, a remarkable Hydrocarbon found in the Wollongong District of the Illawarra Coalfield, N.S. Wales. *Ibid.*, vol. xlvi, pp. 85-92. [1869.]
7123. — Californian Oil is not Asphaltum. 1865.
7124. **Silliman, B., jun., and J. Williamson.** Report upon the Oil Property of the Philadelphia and California Petroleum Company. *Philadelphia*, 1865.
7125. **Silvestri, O.** Sopra un supposto nuovo vulcano della Sicilia. Studio chimico-geologico di una eruzione idrogassosa, accompagnata da fango e bitume. *Atti Acc. Gioen. Sci. Nat.*, ser. 3, vol. v, pp. 239-252. [1871.]
7126. — Sopra alcune Paraffine ed altri Carburi d'Idrogeno omologhi che trovansi contenuti in una Lava della Etna. *Ibid.*, t. xii, pp. 69-97. [1877.]
7127. — Importante eruzione di fango comparsa a Paternò nelle adiacenze dell' Etna ai prima dicembre 1878. *Boll. Vulc. Ital.*, vol. v, p. 131. [1878.]
7128. — Sulle eruzioni fangose nelle adiacenze dell' Etna. *Rend. Acc. Sci. Napoli*, ann. xviii, pp. 110, 111. [1879.]
7129. — Continuazione della eruzione fangosa a Paternò nelle adiacenze dell' Etna e sua fase in data del 20 dicembre 1878. *Boll. Vulc. Ital.*, an. vi, p. 28. [1879.]
7130. — Andamento della eruzione fangosa di Paternò nelle adiacenze dell' Etna in data del 14 gennaio 1879. *Ibid.*, p. 30. [1879.]
7131. — Sulla eruzione di fango a Paternò nelle adiacenze dell' Etna dal suo principio fuoro alla data del 25 maggio 1879. *Rend. R. Acc. Sci. Napoli*, anno xviii, fasc. 4. [1879.]
7132. — L'attuale eruzione di fango, termale salato petrolifero dell' Etna, presso Paternò. *Illustr. Ital. Treves*, Feb. 23, 1879.
7133. — La doppia eruzione dell' Etna scoppiata il 26 maggio 1879. *Catania*.
7134. — Continuazione della eruzione fangosa di Paternò, e sulle condizioni attuali dell' Etna, 25 dicembre 1879. *Boll. Vulc. Ital.*, anno vii, p. 9. [1880.]
7135. — Cronaca dell' eruzione di fango a Paternò e dei fenomeni vulcanici generali dell' Etna durante l'anno 1880. *Osserv. meteorol. Club alp. Ital.*, anno ix [1880.]
7136. — Continuazione del periodo eruttivi (con eruzione di fango) presso Paternò e cronaca dei fenomeni vulcanici generali dell' Etna durante l'anno 1881. *Boll. Assoc. Meteorol. Ital.*, anno x. [1881.]
7137. — Sulla presenza della Paraffina naturalmente cristallizzata nelle geodi di una lava basaltica di Paternò nelle adiacenze dell' Etna. *Boll. Com. geol. Ital.*, vol. xii, pp. 578, 579. [1881.]
7138. — Ricerche chimiche sulla composizione dell' acqua minerale acidulo alcalino-magnesiacio-ferruginosa detta del Fonte Maimonide e volgarmente la Grassa degli sorgenti idrogassose di Paternò alla base S.-O. dell' Etna. *Atti Acc. Gioen. Sci. Nat.*, ser. 3, t. xvi, pp. 189-277. [1882.]
7139. **Simmersbach, B.** Die neueren Petroleumvorkommen in Californien. *Zeitschr. Berg-, Hüt.-Salinenw.*, bd. iii, Abh., pp. 245-264. [1904.]
7140. — Die Mineralvorkommen und die bergbaulichen Verhältnisse in Anatolien, Kurdistan und Arabistan. *Ibid.*, bd. lvi, pp. 417-421. [1908.]
7141. — Ueber den heutigen Stand des Bergbaus in Japan. *Ibid.*, pp. 583-591. [1908.]
7142. **Simms, F. W.** Practical Observations on the Asphaltic Mastic, or Cement of Sevssel, now extensively employed on the Continent for Pavements, Roofing and Flooring, for Hydraulic Works, etc., etc., explaining its Nature and Manipulation, etc. 8vo, *London*, 1837.
7143. **Simon, E.** Ueber das Oel aus dem Braunkohlentheer. *Ann. Phys. Chem.*, bd. cxi, p. 160. [1835.]
7144. **Simonds, F. W.** The Geology of Washington County, Ark. *Ann. Rep. Geol. Surv. Arks.*, 1888, vol. iv, pt. i, pp. 1-154.
7145. — The Geology of Benton County, Ark. *Ibid.*, 1891, vol. ii, pp. 1-75.
7146. — The Minerals and Mineral Localities of Texas. *Univ. Texas Min. Surv. Bull.*, no. 5. Pp. 104. [1902.]
7147. **Simonin, L.** Sur les schistes bitumineux de Vagnas (Ardèche). *Compt. Rend.*, t. lxxiv, pp. 1183-1185. [1867.]
7148. — Les produits souterrains à l'Exposition de 1867. *Rev. Univ. Mines.*, t. xxiii, pp. 74-114. [1868.]
7149. — Souvenirs de mes voyages aux Etats-Unis. *Paris*, 1876.
7150. **Simonovitch, S.** [Geological Explorations on the northeast Slopes of the Trialetic Mountains, Transcaucasia.] *Mat. Geol. Kavk.*, 1878.
7151. — [Geological Investigations in the Upper Part of the Basin of the River Rion, Koutais.] *Ibid.*, 1880, pp. 29-80.
7152. — [Geological Observations on the Jora-Kur Watershed in Tiflis-Samukhe.] *Ibid.*, ser. 3, kn. i. [1898.]
7153. **Simonovitch, S., and A. Sorokin.** [Geological Map of Part of the Koutais Government.] 1887.
- Simonovitch, S., see Barbot de Marni, N. N.; Gabrielov, Th.; and Sorokin, A.**
7154. **Simpich, F.** [Oilfields] Mesopotamia. Standard [Oil] Company seeks Reservoir Sites at Bagdad and Bassorah. *U.S. Cons. Rep.*, no. 355, pp. 139, 140. [1910.]
7155. — Oil Engines for Mesopotamia. *Ibid.*, no. 357, pp. 145-147. [1910.]
7156. — Petroleum Industry, Persia. American Iron Pipes purchased for Development. *Ibid.*, p. 196. [1910.]
7157. **Simpson, L.** Manual of Lubrication. *New York*, 1887.
7158. **Simpson, R. R.** The Jaipur and Nazira Coalfields, Upper Assam. *Rec. Geol. Surv. Ind.*, vol. xxxiv, pp. 199-238; pls. xxiv-xxix. [1906.]
7159. **Sinclair, W. J.** Dermal Bones of Paramyodon from the Asphaltum Deposits of Rancho la Brea, near Los Angeles (Cal.). *Proc. Amer. Phil. Soc.*, vol. xlix, pp. 196-199. [1910.]
7160. **Singer, L.** Beiträge zur Theorie der Petroleumbildung. *Zürich*, 1892.
7161. — Über gegenwärtig gebräuchliche Methoden zur Bestimmung der Schmelz- und Erstarrungstemperatur von Paraffin und Vorschlag zu einer einheitlichen Methode. *Chem. Rev. Fett-Harz-Ind.*, bd. i, no. 7, pp. 2-4; no. 8, pp. 1-5; no. 9, pp. 3-5; no. 11, pp. 1-5; no. 13, pp. 2-4; no. 15, pp. 3, 4. [1894, 1895.]
7162. — Über die Nothwendigkeit der Feststellung einheitlicher Untersuchungs-Methoden in der Petroleum-Industrie. *Ibid.*, no. 29, pp. 2-4. [1895.]
7163. — Ueber die gebräuchlichen Apparate zur Untersuchung von Leuchtölen durch fractionirte Destillation. *Ibid.*, bd. iii, pp. 93-103. [1896.]
7164. — Entgegnung zur vorstehenden Arbeit [von Kissling, no. 4066]. *Ibid.*, pp. 122-127. [1896.]

7165. **Singer, L.** Die Werthbestimmung der Erdölproducte durch fractionirte Destillation. *Chem. Rev. Fett-Harz-Ind.*, bd. iv, pp. 64-68. [1897.]
7166. — Kleinere Mittheilungen aus der Praxis des Mineralölichemikers. *Ibid.*, pp. 92-94, 108-110. [1897.]
7167. — Ueber die Lamansky-Nobel'sche Viscosimeter. *Ibid.*, pp. 243-246. [1897.]
7168. — Ueber Neuerungen auf dem Gebiete der Mineralölanalyse und Mineralölfabrikation [Mineralölindustrie] im Jahre 1901-1910. *Ibid.*, bd. ix, pp. 45-48, 71-74, 98-102, 120-124, 146-150, 174-177; bd. x, pp. 29-32, 47-50, 68-71, 93-96, 118-121, 144-147, 169-173, 194-198, 227-230; bd. xi, pp. 28-30, 46-48, 71-74, 94-96, 120, 121, 142-145, 170, 177, 196-200, 220-223, 248-252, 268-276; bd. xii, pp. 49-52, 68-71, 102-105, 128-132, 154-157, 178-182, 209-214, 233-236, 263-266, 288-293; bd. xiii, pp. 74-76, 105-109, 134-137, 158-161, 182-187; bd. xiv, pp. 62-66, 78-82, 107-112, 133-137, 162-165; bd. xv, pp. 214-217, 242-246, 268-277, 297-301; bd. xvi, pp. 5-9, 189-193, 213-217, 243-247, 268-275, 295-297; bd. xvii, pp. 98-101, 127-131, 154-156, 175-178, 212-215; bd. xviii, pp. 161-165, 190-195, 211-214, 249-257, 275-280, 293-299. [1902-1911.]
7169. — Fortschritte der Mineralölanalyse und Mineralölfabrikation in Jahren 1903-1906. *Oesterr. Chem.-Zeit.*, bd. vii, pp. 510-518; bd. viii, pp. 345-348, 369-372, 392-400; bd. ix, pp. 285-290; bd. x, pp. 222-229. [1904-1907.]
7170. — Die Fortschritte der Petroleum- und Schmieröldestillation. *Petroleum Zeitschr.*, bd. ii, pp. 276-278. [1907.]
7171. — Ueber Viskositätsbestimmungen. *Ibid.*, pp. 555, 556. [1907.]
7172. — Zur Vereinheitlichung der Untersuchungsmethoden von Mineralölen. *Chem. Rev. Fett-Harz-Ind.*, bd. xv, pp. 1, 2. [1908.]
7173. — Geschichtlicher Abriss über die Bestrebungen zur Vereinheitlichung der Untersuchungsmethoden in der Erdöl-Industrie. *Petroleum Zeitschr.*, bd. iv, pp. 977-980. [1909.]
7174. — Zur Untersuchung von Paraffin. *Ibid.*, pp. 1038-1040. [1909.]
7175. — Die Lieferungsbedingungen der Regierung der Vereinigten Staaten für den Kauf von Heizöl und Anleitungen zur Probenahme von Oel und Naturgas. *Ibid.*, bd. vii, pp. 153-158. [1911.]
7176. — Zum "Vorschlag zur zollamtlichen Unterscheidung der unter No. 178 des österreichischen Zolltarifes fallender Mineralschmierne von den Mineralölen No. 177." *Ibid.*, bd. vi, pp. 604, 605, 1911.
- Singer, L.**, see **Engler, C.**, and **Pilat, S. v.**
7177. **Sinn, B. A.** Producer Gas Engines on Shipboard. *Marine Engineering*, vol. x, pp. 7-11. 1905.
7178. **Sintsov, —**, see **Waitzenbreiter, —**.
7179. **Sindak, F.** Vergleichung des Bohrsystems "Raky" mit dem canadischen. *Naphta*, bd. ix, pp. 47-50. [1901.]
7179. — Die Rettungsschrauben und ihre Anwendung. *Ibid.*, pp. 88-90, pl. [1901.]
7180. **Six, A.** Les Hydrocarbures naturels de la série du Pétrole. *Ann. Soc. Geol. Nord.*, t. xi, pp. 334, 335. [1884.]
7181. **Sjögren, H.** Meddelande om slamvulkerna i Baku. *Geol. Fören. Stockh. Förh.*, bd. viii, pp. 416-429. [1886.]
7182. — Ueber das transkaspische Naphtaterrain. *Jahrb. k.-k. geol. Reichs.*, bd. xxxvii, pp. 47-62. [1887.]
7183. — Der Ausbruch des Schlammvulkans Lok-Botan am Kaspischen Meere von 5 Jänner, 1887. *Ibid.*, pp. 233-244. [1887.]
7184. — Ueber die petrographische Beschaffenheit des eruptiven Schlammes von den Schlammvulkanen der Kaspischen Region. *Verh. k.-k. geol. Reichs.*, 1887, pp. 165-170.
7185. — Om jordkorpsansammanpressning under atmosfärrycket. *Oefv. k. Svenska Vet. Akad. Förh.*, 1888, pp. 131-138.
7186. **Sjögren, H.** Om bildningen af Kaspiska hafvets bäcken. *Geol. Fören. Stockh. Förh.*, bd. x, p. 49-74. 1888.
7187. — Ueber die Thätigkeit der Schlammvulkane in der Kaspischen Region während der Jahre 1885-87. *Verh. russ.-k. Min. Ges.*, bd. xxiv, pp. 1-22. [1888.]
7188. — Uebersicht der Geologie Daghestans und des Terek-Gebietes. *Jahrb. k.-k. geol. Reichs.*, bd. xxxix, pp. 417-438. [1889.]
7189. — Om de svenska jernmalmslagrens genesis. *Geol. Fören. Stockh. Förh.*, bd. xiii, pp. 373-435. [1891.]
7190. — Preliminära meddelanden från de Kaukasiska naftafalten. *Ibid.*, pp. 89-110, 223-255, pl. vii [1891]; bd. xiv, pp. 383-422, pl. ix. [1892.]
7191. — Das geologische Vorkommen des Petroleum im Kaukasus. *Zeitschr. prakt. Geol.*, bd. ii, pp. 286-288. [1894.]
7192. — Om några Slamvulkanutbrott i Kaspiska Regioner under Aren 1892-96. *Geol. Fören. Stockh. Förh.*, bd. xix, pp. 91-105. [1897.]
7193. — Om Framställning af Radium ur Kolm från Vastergotland och Nerike och om Destillationsprodukterna af bituminös Alunskiffer. *Ark. Kem. Min. Geol. k. Svenska Vet. Akad.*, bt. ii, no. 5. Pp. 6. [1905.]
7194. **Skalkovski, K.** [Kerosene Industry of South Russia.] *Gern. Journ.*, 1867, t. 3, pp. 461-477.
7195. — [Mining Industry of Russia to 1877.] *Ibid.*, 1879, t. 2, pp. 39-151.
7196. **Skalweit, J.** Apparate und Methoden zur Prüfung von Petroleum. *Hann. Monatschr.*, bd. ii, p. 89. [1879.]
7197. — How is Petroleum to be Examined? *Chem. News*, vol. xliii, pp. 76-78. [1881.]
7198. **Skertchly, S. A. R.** Oil in Mexico. *Mining Mag.*, vol. iii, pp. 283-286. [1910.]
7199. **Skey, W.** Notes upon the Mineral Oils of New Zealand. *Trans. New Zealand Inst.*, vol. vi, pp. 252-259. [1874.]
7200. — Notes on the Formation and Constitution of Torbanite and similar Minerals. *Ibid.*, vol. vii, pp. 384-387. [1875.]
7201. — Preliminary Note on the Presence of one or more Hydrocarbons of the Benzol Series in the American Petroleum, also in our Petroleum. *Ibid.*, vol. xi, pp. 469, 470. [1879.]
7202. — On the supposed Paraffin Deposit at Waiapu. *Ibid.*, vol. xiv, pp. 397-399. [1882.]
7203. — Kerosene Shale. *Ann. Rep. Col. Mus. Lab. New Zealand*, vol. xxiii, pp. 50, 51; vol. xxv, pp. 56, 57; vol. xxix, p. 19; vol. xxxi, p. 10. [1889-1898.]
7204. — On the Nature of Stinkstone (Anthraconite). *Trans. N. Zealand Inst.*, vol. xxv, pp. 379, 380. [1895.]
- Skey, W.**, see **Hector, I.**
7205. **Skinner, R. P.** Petroleum-burning Motors for Agricultural Purposes (Russia). *U.S. Cons. Rep.*, no. 356, p. 54. [1910.]
7206. — Asphalt Industry, Germany. Imports of Asphalt considerable. Italy the Principal Source. *Ibid.*, no. 357, p. 194. [1910.]
7207. **Skita, A.** Ueber Naphten und Naphtensäuren. *Zeitschr. angew. Chem.*, bd. xxii, pp. 1930, 1931. [1909.]
- **Skrakhovski, —** de, see **Spornil, —**.
7208. **Skrine, F. H.** Baku and its Oil Springs. *Pal Mall Magazine*, June 1899.
7209. **Sladen, E. B.** Notice of a Recent Eruption from one of the Mud Volcanoes in Cheduba. *Rec. Geol. Surv. India*, vol. xv, pp. 141, 142. [1882.]
7210. — Notice of a further Fiery Eruption from the Minbyin Mud Volcano of Cheduba Island, Arakan. *Ibid.*, vol. xvii, p. 142. [1884.]
7211. **Slau-Kantschieder, J.** Chemische Zusammensetzung dalmatischer bituminöser Kalksteine. *Chem. Rev. Fett-Harz-Ind.*, bd. ix, pp. 64, 65. [1902.]

7212. **Slosson, E. E.** The Analysis of the Salt Creek Petroleum. *School of Mines, Univ. Wyo., Bulletin, Petroleum Series*, no. 1, pp. 23-47. [1896.]
7213. ——— Analysis of Popo Agie, Lander, and Shoshone Petroleum. *Ibid.*, no. 2, pp. 21-34. [1897.]
7214. **Slosson, E. E., and L. C. Colburn.** The Heating Value of Wyoming Coal and Oil. *School of Mines, Univ. Wyo., Bulletin*, no. 2, 1895.
- Slosson, E. E., see Knight, W. C.**
7215. **Slutchevski.** — [Asphalt as Building Material.] *Tiflis*, 1873.
7216. **Smalley, E. V.** Striking Oil. *Century*, vol. xxvi, pp. 323-339. [1883.]
- Smith, A. W., see Mabery, C. F.**
7217. **Smith, C. D.** Oil and Gas in Pawhuska Quadrangle, Oklahoma. *Bull. U.S. Geol. Surv.*, no. . [191.]
- Smith, C. D., see Taff, J. A.**
7218. **Smith, F. P.** A Machine for Testing the Ductility of Bituminous Paving Cements. *Proc. Amer. Soc. Test. Mat.*, vol. ix, pp. 594-599. [1909.]
7219. **Smith, F. S.** Note on Ozokerite. *Amer. Chem. Journ.*, vol. vi, p. 247. [1884.]
7220. **Smith, J. L.** On the History and Statistics of the Trade and Manufacture of Canadian Salt. *Rep. Geol. Surv. Canada*, 1874-75, pp. 267-300. [1876.]
7221. ——— Puits de Gaz en Pennsylvanie. *Ann. Chim. Phys.*, sér. 5, t. viii, pp. 566-571. [1876.]
7222. ——— Researches on the Solid Carbon Compounds in Meteorites. *Amer. Journ.*, ser. 3, vol. xi, pp. 388-395, 433-442. [1876.]
7223. ——— Rapport sur le pétrole. *Monit. Scient.*, t. xxii, pp. 68-108. [1880.]
7224. **Smith, R. B.** Memoir on Indian Earthquakes. *Journ. As. Soc. Beng.*, vol. xii, pp. 1029-1056\* (60 pp.). [1843.]
7225. **Smith, T. P.** An Account of a Kettle for boiling Inflammable Fluids. *Trans. Amer. Phil. Soc.*, vol. iv, pp. 431, 432. [1799.]
7226. **Smith, W.** Extinguishing Fires in Tar-Distilleries, etc. *Chem. News*, vol. xxxix, p. 190. [1879.]
7227. ——— A Contribution to our Knowledge of the Soluble and Resinoid Constituents of Bituminous Coal. *Journ. Soc. Chem. Ind.*, vol. x, pp. 975-980. [1891.]
7228. **Smith, W. D.** The Essential Features of the Geology of the Philippine Islands. *Philipp. Journ. Sci.*, vol. 5, A, pp. 307-344. [1910.]
7229. **Smith, W. S. T., and C. E. Siebenthal.** Joplin, Mo. Fo. 148, *U.S. Geol. Surv.*, 1907.
7230. **Smithells, A.** Note on the Structure of Luminous Flames. *Journ. Chem. Soc.*, vol. lxi, pp. 217-226, pl. II. [1892.]
7231. ——— On Flame Temperatures and the Acetylene Theory of Luminous Hydrocarbon Flames. *Ibid.*, vol. lxvii, pp. 1049-1062. [1895.]
7232. **Smithells, A., and H. Ingle.** The Structure and Chemistry of Flames. *Ibid.*, vol. lxi, pp. 204-216, pl. I. [1892.]
7233. **Smyth, R. B.** Mining and Mineral Statistics (of Victoria). Intercolonial Exhibition Essays, 1866, 8vo, Melbourne, 1866.
- Smythe, J. A., see Garrett, F. C.**
7234. **Snaddon, J. B.** Description of the Duddingston Shale-mines, and the Niddrie Castle Crude-oil Works. *Trans. Inst. Min. Eng.*, vol. xxvi, pp. 122-133. [1903.]
7235. ——— Description of the Aërial Ropeway from the Shale Mines to the Oil-works at Oakbank, Mid-Calder. *Ibid.*, vol. xlii, pp. 300-307. [1912.]
- Snell, J. F., see Atwater, W. O.; and Sherman, H. C.**
7236. **Sobrero, A.** Sul calcare bituminoso di Manopello. *Atti Soc. Ing. Ind. Torino*, 1869.
7237. ——— Preparazione dei legnami col residuo bituminoso del petrolio d'America. *Atti Acc. Sci. Torino*, t. II, 648-653; t. III, pp. 111-121; t. V, 494-499. [1867, 1871.]
- Sôtet, S., see Kovacs, J.**
7238. **Sohncke, L., and G. Wagner.** Naturwissenschaftliche Chronik des Grossherzogthums Baden und benachbarter Länder 1881 und 1882. *Verh. nat. Ver. Karlsruhe*, 1883, pp. 59-128.
7239. **Sokolov, D. V.** La Question de l'Etage Ferganien. *Bull. Soc. Imp. Nat. Mosc.*, n.s., vol. xxiii, pp. 44-93. [1910.]
7240. **Sokolov, N. A.** Kosmischer Ursprung der Bitumina. *Ibid.*, ser. 2, t. iii, pp. 720-739. [1890.]
7241. ——— [Notes on Asphalt Literature.] *Zap. Imp. Russk. Tekhn. Obsch.*, g. xxx, pp. 127-139. [1896.]
7242. ——— [Geological Explorations in the Caucasus in 1901.] *Bull. Com. géol. Russ.*, t. xx, pp. 575-589, pl. vii. [1901.]
7243. ——— [Rules for the testing of petroleum products.] *Zap. Imp. Russk. Tekhn. Obsch.*, g. xxxvi, Trudi, pp. 681-732. [1902.]
7244. ——— [On Methods of Quantitative Determination of Oil in Mazut.] *Ibid.*, g. xxxvii, Trudi, pp. 391-401. [1903.]
7245. ——— [Examination of Samples of Oil and Kir from Sakhalin.] *Ibid.*, pp. 401, 402. [1903.]
7246. ——— [Calorimetric Bomb for determining the Heat of Combustion of Organic Compounds.] *Zap. Imp. Russk. Tekhn. Obsch.*, g. xxxviii, Trudi, pp. 537-553. [1904.]
7247. ——— [On the calorific value of beeswax, and on the application of calorimetric methods to the decision of some analytical questions.] *Jurn. Russ. Fiz. Khim. Obsch.*, t. xxxvii, pp. 818-822. [1905.]
7248. **Sokolovski, N. A.** [System of Boring without removal of Instruments.] *Gorn. Journ.*, 1879, t. 2, pp. 189-197.
7249. ——— [On the Question of Geological Search for Naphtha in the Caucasus, and Report on the Structure of the Balakhani-Sabuntchi Oil-field in connection with its suggested exhaustion.] *Tiflis*, 1883.
7250. ——— [Explanation of the Geological Conditions of Occurrence, and of the Origin, of Petroleum.] 8vo, Baku, 1886.
7251. ——— Gisement de Naphte en Gourie sur la Territoire de Batoum. 1886.
7252. ——— [Oil-fountains at Baku, and how to control them.] *Gorn. Journ.*, 1890, t. 3, pp. 193-228.
7253. ——— [Oil and Ozokerite Deposits of Tcheleken Island (Caspian Sea).] *Ibid.*, 1891, t. 3, pp. 491-526.
7254. ——— Einiges über Verröhrung der Bohrlöcher und die Dauerhaftigkeit der heutigen Bohrröhren. *Naphtha*, bd. xiv, pp. 449-454. [1906.]
7255. ——— [On Various Defects in Boring.] *Nepht. Dielo*, 1907, no. 11.
7256. ——— Widerstandsfähige Bohrröhren. *Ory. Ver. Bohrtechn.*, bd. xv, pp. 88-91. [1908.]
7257. ——— Les Tubes de Sonde de haute résistance. *Compt. Rend. Congr. internat. Pétrole*, sess. 3, t. ii, pp. 471-478. [1910.]
7258. **Solinus, C. J.** Memorabilia. 8vo, n.p., n.d. [14.]
7259. **Soltan, W. E.** Petroleum Deposit in Bavarian Tyrol. *Board of Trade Journ.*, vol. lxxiii, p. 474. [1911.]
7260. **Sommer, A.** A new Method and Apparatus for the Determination of the Specific Gravity of Semi-Solid Substances. *Proc. Amer. Soc. Test. Mat.*, vol. ix, pp. 602-604. [1909.]
7261. ——— Necessary Reforms in Specifications for Petroleum Products. *Ibid.*, vol. x, pp. 458-471. [1910.]
7262. ——— Methods of Asphalt Examination. *Journ. Ind. Eng. Chem.*, vol. ii, pp. 181-187. [1910.]
- Sommer, F., see Ulzer, F.**
7263. **Sorabji, Kh. B. B.** On Some New Paraffins. *Journ. Chem. Soc.*, vol. xviii, pp. 37-41. [1885.]
7264. **Soreau, R.** La Vapeur, le Pétrole, et l'Electricité dans les Automobiles. *Mem. Soc. Ing. Civ.*, 1898, vol. I, pp. 1008-1034.

7265. **Sorge, K.** Vorkommen und Verwendung des natürlichen Gases in Pittsburg, und der Einfluss desselben an der dortigen Industrie. *Stahl und Eisen*, bd. vii, pp. 93-108, map. [1887.]
7266. **Sorge, R.** Das Spülbohren nach Erdöl. *Petroleum Zeitschr.*, bd. ii, pp. 1-4, 50-53, 92-95. [1906.]
7267. ——— Tiefbohrtechnische Studien über Oelgrubenbetrieb und Spülbohrung. 8vo, Berlin, 1908.
7268. ——— Ueber den Einfluss des Schöpfens auf den Zufluss von Wasser und Erdöl nach dem Bohrloche. *Compt. Rend. Congr. internat. Pétrole*, sess. 3, t. ii, pp. 515-520. [1910.]
7269. **Sorokin, A., and S. Simonovitch.** [Geological Map of Surakhani, Apscheron, 1:8400.] *Tiflis*, 1887.
- Sorokin, A., see Simonovitch, S.**
7270. **Soto, H. de —.** Automobile Steam Fire Engine. *U.S. Cons. Rep.*, no. 356, pp. 55, 56. [1910.]
7271. **Soulié, E.** Notes sur les essais faits en vue d'appliquer le pétrole au chauffage des chaudières à vapeur. *Ann. Gén. Cir.*, t. vi, p. 164-171, pl. ix. [1867.]
7272. **Soulié, E., and H. Haudouin.** Le Pétrole. Ses gisements, son exploitation, son traitement industriel, ses produits dérivés, ses applications à l'éclairage et au chauffage. Paris, 1865.
- Southcombe, J. E., see Worrall, G. W.**
7273. **Souther, H.** Testing Lubricating Oils. *Proc. Amer. Soc. Test. Mat.*, vol. viii, pp. 593-595. [1908.]
7274. **Spallanzani, L.** Lettere due sopra un viaggio nei monti del Reggiano, ed al lago Ventasso. *N. Racc. Opusc. Sci.*, t. ix. [1759.]
7275. ——— Récit des phénomènes observés à la Salsa de Querzuola. Berne, 1795.
7276. ——— Observations faites par le Dr. Dom. Gentili sur la Salsa de Querzuola, et surtout sur l'éruption du 22 avril, 1796. Berne, 1796.
7277. ——— Sur les salses du Modénois. *Ann. Chim. Phys.*, t. xxii, pp. 255-257. [1797.]
7278. ——— Viaggio alle due Sicilie ed alcuni parti degli Apennini, 17— Milan, 1824.
7279. **Spallanzani, P.** I depositi di forza in Italia ed in particolari nella provincia di Reggio-Emilia. *Reggio-Emilia*, 1876.
7280. **Span, S.** Some Account of the Pitch Lake in the Island of Trinidad. *Trans. Linn. Soc.*, vol. viii, pp. 251-253. [1807.]
7281. **Spanier, E.** Zur Kenntniss der Wirkung des Schwefels auf Kohlenwasserstoff. 1910.
7282. **Spasski-Antonovov, —.** [Baku Oil Wells.] *Zakavk. Vestn.*, 1848, no. 24.
7283. ——— [Fire-worship at Surakhani.] *Ibid.*, no. 27.
7284. ——— [Apscheron Peninsula.] *Mosketryanin*, t. v, no. 20. [1849.]
7285. ——— [Journey from Baku to St. Petersburg in 1849. The Caspian from Baku to the Volga. Natural Resources of the Apscheron Peninsula.] *Ibid.*, 1851, no. 6.
7286. ——— [Submarine Phenomena of the Baku Roadstead.] *Zap. Kavk. Od. Imp. Russk. Geogr. Obsch.*, t. ii, pp. 242-246. [1853.]
7287. **Speller, F. N.** Materials and Properties of Wrought Pipe. *Proc. Eng. Soc. W. Penns.*, vol. xxii, pp. 459-480. [1907.]
- Spencer, A. C., see Hayes, C. W.**
7288. **Spengler, —.** Ueber ein neues Vorkommen von Asphalt im Zechstein zu Kamsdorf. *Zeitschr. deutsch. geol. Ges.*, bd. vi, pp. 405-408. [1854.]
7289. **Spennrath, I.** Chemische und physikalische Untersuchung der gebräuchlichen Eisenanstriche. *Verh. Ver. Beförd. Gewerbl. Preuss.*, bd. lxxiv, pp. 245-276. [1895.]
7290. **Spicer, J. A.** A Texas Oil Discovery [Kerrville]. *Eng. Min. Journ.*, vol. lxxvii, pp. 208, 366. [1904.]
7291. **Spiegel, L.** Zur Frage nach der Constitution des Fichtelits. *Ber. deutsch. chem. Ges.*, bd. xxii, pp. 3369-3371. [1889.]
7292. **Spiegel, E.** Die praktische Bedeutung des Schmelzpunkts von Paraffin, und Mischungen von solchem mit hochschmelzenden Stoffen. *Chem.-Zeit.*, bd. xxx, p. 1235. [1906.]
7293. **Spielmann, —.** Mémoire sur le bitume d'Alsace. *Hist. Acad. Roy. Sci. Berlin*, t. xiv, pp. 105-128. [1758.]
- Spilker, A., see Krämer, G.**
7294. **Spindler, E.** [Heptanaphthene from Caucasian Naphtha.] *Journ. Russk. Fiz. Khim. Obsch.*, t. xxiii, pp. 40-44. [1891.]
7295. **Spinelli, A. G.** La "salsa" di Rocca Santa Maria, l'Provincia di Modena. 1st Aug., 1901.
7296. **Spireseu, J.** The Bustenari Field, Roumania. *Petrol. Rev.*, vol. viii, pp. 237-240. [1903.]
7297. **Spöring, H. D., and J. Brovallius.** Versuch, eine besondere unterirdische Pettigkeit betreffend, die in Finnland gefunden worden. *K. Svenska Vet.-Akad. Handl.*, bd. iv, pp. 1-12. [1743.]
7298. **Spornii, —, and — de Skrahovski.** [Asphalt, Bitumen, and their Uses.] *St. Petersburg*, 1876.
7299. **Spratt, T. A. B., and E. Forbes.** Travels in Lycia, Milyas, and the Cibyratis. 2 vols. 8vo, London, 1847.
- Spratt, T. A. B., see Forbes, E.**
7300. **Sprengel, H.** A Method of Determining the Specific Gravity of Liquids with Ease and Great Exactness. *Journ. Chem. Soc.*, vol. xxvi, pp. 577-581. [1873.]
7301. **Spring, W.** Sur la cause de la fétidité de certains calcaires. *Ann. Soc. Géol. Belg.*, t. xvi, p. lxvi. [1890.]
7302. ——— Quelques Expériences sur l'imbibition du Sable par les Liquides et les Gaz, ainsi que sur son Tassement. *Bull. Soc. belge. Géol.*, t. xvii, Mém., pp. 13-32. [1903.]
7303. **Spry, H. H.** A Three-weeks' Sail in Search of Health, Province of Arracan. Khyok-Phyoo, its harbour, productions, capabilities, geological features; visit to an active [mud] volcano. *Journ. As. Soc. Beng.*, vol. x, pp. 138-147. [1841.]
7304. **Spurr, J. E.** A Reconnaissance in South-western Alaska in 1898. 20th Ann. Rep. U.S. Geol. Surv., pt. vii, pp. 31-264, pls. vii-xiii, maps 4-14. [1900.]
7305. ——— The Mineral Resources of Turkey. *Eng. Min. Journ.*, vol. lxxiv, p. 308, 438. [1902.]
7306. **Squire, W. S.** On the Purification of Alcohol by Means of Hydrocarbons. *Journ. Soc. Chem. Ind.*, vol. viii, pp. 441-444. [1889.]
7307. **Stacey, B. F.** An Essay on Paraffine and its Uses in Pharmacy. *Proc. Amer. Pharm. Assoc.*, 1875, p. 629.
- Stache, G., see Hauer, F. R. v.**
7308. **Stack, E.** Six Months in Persia. 2 vols. 12mo. London, 1882.
- Stadnikov, G., see Markovnikov, V.**
7309. **Staff, H. v., and R. Wedekind.** Der Oberkarbon. Foraminiferen-Sapropelit Spitzbergens. *Bull. Geol. Inst. Upsala*, bt. x, pp. 81-123, pls. ii-iv. [1910.]
7310. **Stahl, A. F.** Mittheilungen aus dem Kaukasus (Naphthaerzigeligkeiten). *Chem.-Zeit.*, bd. xiii, pp. 935, 1159, 1160. [1889.]
7311. ——— [Persian Petroleum.] *Trudi Bak. Od. Imp. Russk. Techn. Obsch.*, 1893, Nov.-Dec., pp. 36-42.
7312. ——— Die Naphtavorkommen im Deltagebiet der Flüsse Sagis und Embas (Uralsteppe). *Chem. Zeit.*, bd. xxiii, pp. 22, 40. [1899.]
7313. ——— Zur Theorie der Naphthabildung. *Ibid.*, pp. 144, 145. [1899.]
7314. ——— Das Naphthavorkommen von Woznesensk bei Wladikawkas. *Ibid.*, bd. xxiii, p. 161. [1899.]
7315. ——— Einiges über die russischen Naphthageblete. *Ibid.*, bd. xxiv, p. 792. [1900.]
7316. ——— The Grosney [Grozni] Oil Fields. *Petroleum*, vol. i, p. 365. [1900.]
7317. ——— The Woznesensk Oil Fields. The Tifis Oil Fields. *Ibid.*, p. 480. [1901.]
7318. ——— Some Russian Oil Fields in Embryo. The Oil Fields of the Temir-Khan-Shura District. *Ibid.*, pp. 621, 622. [1901.]
7319. ——— Der Naphthabacillus. *Chem.-Zeit.*, bd. xxv, p. 640. [1901.]

7320. **Stahl, A. F.** Die Bakuer Naphtha-Krisis und Ueberproduction. *Chem.-Zeit.*, bd xxv, pp. 969, 970. [1901.]
7321. — Kachetien, ein Naphthagebiet Transkaukasens. *Ibid.*, bd. xxvi, pp. 9, 10. [1902.]
7322. — Vulcanismus im Naphtharayon von Baku. *Ibid.*, pp. 307, 308. [1902.]
7323. — Petroleum in Persia. A Geological Study. *Petroleum*, vol. iii, p. 623. [1903.]
7324. — Some Theories of the Formation of Petroleum. *Ibid.*, pp. 935-937, 988-990. [1903.]
7325. — Zur Frage der Entstehung des Erdöles und der Steinkohlen. *Chem.-Zeit.*, bd. xxix, pp. 665-667. [1905.]
7326. — Einige Bemerkungen zum Artikel Prof. H. Potonié's: zur Frage nach der Urmaterialien der Petrolea. *Ibid.*, bd. xxx, p. 18. [1906.]
7327. — Einiges über die Lagerungsverhältnisse des Erdöls. *Ibid.*, p. 346. [1906.]
7328. **Stanford, E. C. C.** The Manufacture of Kelp. *Technologist*, vol. ii, pp. 285-302. [1862.]
7329. **Stange, M.** [Designing of Oil Lamp Chimneys.] *Jurn. Manuf. Torg*, 1866, no. 5, pp. 24, 25.
- Stange, M.**, see **Holde, D.**
7330. **Stange, M.**, and — **Markisio.** [Process of Preparation of Special Illuminating Liquids from Petroleum, etc.] *Jurn. Manuf. Torg*, t. iv, pp. 165, 166. [1865.]
7331. **Stansbury, H.** Exploration and Survey of the Valley of the Great Salt Lake of Utah. 8vo, Philadelphia, 1852.
- Stanski, S.**, see **McGarvey, W. H.**
7332. **Stappenbeck, R.** Uebersicht über die nutzbaren Lagerstätten Argentinien und der Magelhaensländer. *Zeitschr. prakt. Geol.*, bd. xviii, pp. 67-81. [1910.]
7333. — La Precordillera de San Juan y Mendoza. *An. Ministr. Agric. Republ. Argent.*, Secc. Geol., t. iv, no. 3. Pp. 187, 15 pls, 7 folding pls. [1910.]
7334. — Region petrolifera de Comodoro Rivadavia. *Ibid.*, t. v, no. 2, pp. 72-108, 4 pls. [1910.]
- 7335 (blank).
- Starkel, W.**, see **Pilat, S. v.**
7336. **Starostescu, N. C.** Sur le Gaz Naturel. *Compt. Rend. Congr. internat. Pétrole*, sess. 3, t. ii, pp. 453-464. [1910.]
7337. **Starzew, E. J.** [Baku's Naphtha-production.] *Baku*, 1886.
7338. **Stas, J. S.** Leuchtstoffe. *Jahresb. chem. Technol.* 1865, pp. 845-849.
7339. **Stavenov.** — Zur Tiefbohrung in Körösmezö. *Allg. österr. Chem.-Techn.-Zeit.*, bd. x, p. 1428. [1892.]
7340. **Stearns, R. E. C.** Oil Creek Petroleum known in the last Century. *Amer. Nat.*, vol. vi, p. 638. [1872.]
7341. **Stearns, W. B.** Some Observations on Motor-propelled Vessels, and Notes on the Bermuda Race. *Trans. Soc. Naval Archit. Eng.*, vol. xv, pp. 103-116. [1907.]
7342. **Steen, G. J. A.** Gas-, Petroleum- en Benzinmotoren. 8vo, Leyden, 1898.
7343. **Steenstrup, J. J. S.** Geognostisk-geologisk Undersøgelse af Strovmoserne Vidnesdam og Lillemose i det nordlige Sjaelland. *Dansk. Vid. Selsk. Nat. Aft.*, bd. ix, pp. 17-120. [1842.]
7344. **Stefanescu, A.** Coup d'œil sur le Petrole Roumain. 8vo, Campina, 1910.
7345. **Stefanescu, G.** Relation sommaire des travaux du Bureau Géologique durant la campagne des années 1884, 1885. *An. Burol. Geol. Roman.*, t. ii, pp. 1-45; t. iii, pp. 4-87. [1885, 1886.]
7346. **Stefani, C. de.** Sui pozzi di petrolio nel Parmense e sulle loro spese di impianto e di esercizio. *Giorn. Geol. Pratt.*, t. ii, pp. 1-22. [1904.]
7347. **Stegl, K.** Ueber die fossilen Brennmaterialien Italiens, und die Braunkohlenwerke Ribolla und Oesteani in der Provinz Grosseto. *Oesterr. Zeitschr. Berg-Hüt.*, bd. iv, pp. 509-512, 524-529, 540-542, 552-555, 560-563; map 1: 75,000. [1907.]
7348. **Stein, P.** Verfahren und Einrichtungen zum Tiefbohren. 8vo, Berlin, 1905.
7349. — Die Wasserspülung beim Bohren nach Petroleum. *Naphtha*, bd. xiii, pp. 71-73. [1905.]
7350. — Ueber höhle und massive Fanggestänge (Rettungstängen), mit besonderer Berücksichtigung ihrer Anwendung auf Erdöl-Gruben. *Petroleum Zeitschr.*, bd. v, pp. 1163-1165. [1910.]
7351. — Ueber höhle und massive Fanggestänge. *Ibid.*, bd. vi, pp. 486-488. [1911.]
7352. **Steingraber.** — Ueber die Entflammbarkeit des Leuchtpetroleums. *Oesterr. Chem.-Zeit.*, bd. iii, pp. 589-594. [1900.]
7353. — Spezifisches Gewicht und Viskosität. *Petroleum Zeitschr.*, bd. i, pp. 578-581. [1906.]
7354. **Steinhardt, W. A.** Schmiedereinrichtungen mit Rohöfheizung. *Ibid.*, bd. iii, pp. 509, 510. [1908.]
- Steinkopf, W.**, see **Engler, C.**
7355. **Steinmann, G.** Ueber Jura und Kreide in den Anden. *N. Jahrb.*, 1862, bd. I, pp. 166-170.
7356. **Steinmann, J. A.** [Visit to the Mines and Works of Caucasia and Transcaucasia.] *Gorn. Journ.*, 1869, t. 4, pp. 1-29.
7357. **Steinworth, H.** Nachträgliches zur Petroleumfrage. *Jahresh. nat. Ver. Lüneburg*, 1892, p. 98.
7358. **Stelfox, J. A.** First Season's Experience of Carburetted Water Gas. *Trans. Incomp. Gas Inst.*, 1894, pp. 82-108.
7359. **Stella, A.** A proposito di Genesi del Giacimenti di Petrolio. *Rass. Min.*, t. xi, no. 1. [1899.]
7360. **Stellers, G. W.** Beschreibung von dem Lande Kamschatka, dessen Einwohnern, deren Sitten, Nahmen, Lebensart, und verschiedenen Gewohnheiten. Maps. 8vo, Frankfurt, 1774.
7361. **Stelzner, A.** Beiträge zur Geologie der Argentinischen Republik. *Palaeontographica*, Suppl.-bd. iii, 1. P. 329, 4 pls. [1885.]
7362. **Stelzner, H.** Vaseline. *Seifensied.-Zeit.*, bd. xxxiv, pp. 222, 242, 261, 262, 317, 318. [1907.]
7363. **Stenhouse, J.** On the Employment of Paraffine for Waterproofing. *Journ. Franklin Inst.*, vol. lxxix, pp. 340, 341. [1865.]
7364. **Stepanov, A. I.** Bestimmung des Aschengehaltes von Mineralschmierölen. *Chem.-Zeit. Rep.*, bd. xvi, p. 348. [1892.]
7365. — [Investigation of the Conditions of Burning Mineral Oils in Lamps.] *Zap. Imp. Russk. Tekhn. Obsch.*, g. xxix, Jan., Trudi, pp. 31-103, 4 pls. [1895.]
7366. — [Contributions to the Preliminary Purification of Petroleum with Lime.] *Trudi Bak. Old. Imp. Russk. Tekhn. Obsch.*, bd. xiii, p. 300. [1898.]
7367. — [Determination of the Viscosity and Internal Friction of Lubricants.] *Zap. Imp. Russk. Tekhn. Obsch.*, g. xxxiv, Trudi, pp. 397-409. [1900.]
7368. **Stepanov, N.** [Daghestan Petroleum.] *Viestn. Obsch. Tekhn.*, 1898, pp. 392, 393.
- Stepanov, A. I.**, see **Lisenko, K.**
7369. **Stephan, M. J.** Notes on the Occurrence of Oil in South Africa. *Trans. Geol. Soc. S. Africa*, vol. viii, pp. 28-32. [1905.]
7370. — Petroleum Prospects in South Africa. *Petrol. Rev.*, vol. xviii, pp. 187-189. [1908.]
7371. **Stephani, O.** Ueber das Welser Erdgas. *Zeitschr. angew. Chem.*, bd. xvi, pp. 27-32. [1903.]
7372. **Stephens, T.** Remarks on Tasmanite or Dysodil. *Proc. R. Soc. Tasman.*, 1876, March, p. 5.
7373. **Stephenson, G. B.** Petroleum Engines. Great saving in the Cost of Fuel claimed. *U.S. Cons. Rep.*, no. 357, p. 143. [1910.]
7374. **Stephenson, W. M.** The Location of Deposits of Petroleum. *Petroleum*, vol. ii, pp. 1296-1300. [1902.]
7375. **Stepski, R. v.** Ueber die Producte der gemässigten Verbrennung von Isopentan, n-Hexan, und Isobutylalkohol. *Monatsh. Chem.*, bd. xxiii, pp. 773-801. [1902.]

7376. **Stern, A.** Die Verwendung des Benzins zur Erzeugung von Gas für Leucht-, Kraft- und Heizzwecke. *Petroleum Zeitschr.*, bd. ii, pp. 1084-1090. [1907.]
7377. **Stern, B.** Ein Besuch an den Naphtaquellen auf Apscheron. *Das Ausland*, bd. lxxv, pp. 713-718, 731-734, 745-748. [1892.]
- Stierry, C.**, see **Forded, J.**
7378. **Stewart, B.** Contribution to the Composition of Shale Naphtha. *Journ. Soc. Chem. Ind.*, vol. xix, pp. 986-989. [1900.]
7379. **Stewart, D. R.** On the Occurrence of Petroleum in a Shale Mine at Broxburn. *Ibid.*, vol. vi, pp. 128-130, 352. [1887.]
7380. ——— The Flashpoint and Point of Danger in Mineral Oils. *Chem. News*, vol. lxxvii, pp. 291-293. [1893.]
7381. ——— The Abel Test and the Standard of Safety for Mineral Oil. *Ibid.*, vol. lxx, pp. 284, 285. [1894.]
7382. ——— The Standard of Minimum Flash-point for Mineral Oil. *Journ. Soc. Chem. Ind.*, vol. xv, pp. 173-179, 335, 336. [1896.]
7383. ——— The Oxidation of Mineral Oils. *Ibid.*, vol. xviii, pp. 239-246. [1899.]
7384. ——— Refining Shale Oil. *Ibid.*, pp. 248, 249. [1899.]
7385. ——— Paraffin Oil and Petroleum. *Ibid.*, vol. xix, pp. 989-992. [1900.]
7386. ——— The Shale Oil Industry of Scotland. *Econ. Geol.*, vol. iii, pp. 573-598. [1903.]
- Stewart, D. R.**, see **Bell, C.**, and **Cadell, H. M.**
7387. **Stener, A.** Ueber ein Asphaltvorkommen bei Mettenheim in Rheinhessen. *Notizbl. Ver. Erdk. Darmstadt*, f. 4, bd. xxvi, pp. 35-48. [1907.]
7388. **Stevens, P.** Reports on the Trade of the Consular District of Batoum [including Baku] for the years 1892-1910. *Dipl. Cons. Rep.*, ann. ser., nos. 1191, 1371, 1562, 1717, 1903, 2067, 2264, 2424, 2623, 2782, 2979, 3206, 3366, 3566, 3775, 3996, 4198, 4457, 4683. [1893-1911.]
7389. **Stevens, R. P.** Bitumen. *Trans. Amer. Inst. N. York*, 1860-1861, pp. 468, 469.
7390. ——— The Petroleum Rocks. *Sci. Amer.*, ser. 2, vol. xliii, p. 2, section. [1865.]
7391. **Stevenson, D. A.** Ailsa Craig Lighthouse and Fog Signals. *Proc. Inst. Civ. Eng.*, vol. lxxxix, pp. 297-303, pl. viii. [1887.]
7392. **Stevenson, J. J.** Notes on the Geology of West Virginia. No. II. *Proc. Amer. Phil. Soc.*, vol. xiv, pp. 370-401. [1875.]
7393. ——— Report of Progress in the Greene and Washington District of the Bituminous Coal-fields of Western Pennsylvania. *Second Geological Survey of Pennsylvania*, K. 8vo, Harrisburg, 1876.
7394. ——— Report of Progress in the Fayette and Westmoreland Districts of the Bituminous Coal-fields of Western Pennsylvania. *Ibid.*, KK, KKK. 8vo, Harrisburg, 1877, 1878.
7395. ——— The Chemung and Catskill (Upper Devonian) on the Eastern Side of the Appalachian Basin (Oil Sands). *Proc. Amer. Assoc.*, vol. xi, pp. 219-247. [1892.]
7396. **Stewart, B.** An Account of some Experiments on the Melting-point of Paraffin. *Proc. Lit. Phil. Soc. Manch.*, vol. xii, pp. 15-18. [1873.]
7397. **Stewart, C. E.** The Petroleum Fields of South-eastern Russia, and the result of the Proceedings of the Russian Petroleum Conference assembled at Baku. *Suppl. Chamber of Commerce Journ.*, Nov. 5, 1886.
7398. ——— On the Use of Petroleum as Fuel in Steamships and Locomotives, based on its employment in that way on the Caspian Sea and in the Trans-Caspian Region. *Journ. Roy. United Serv. Inst.*, vol. xxx, pp. 927-949, pl. xxv. [1886.]
7399. ——— Report on the Petroleum Districts on the Red Sea Coast. *Geol. Surv. Egypt*, 1888.
7400. **Stewart, J. L.** Memoranda on the Peshawur Valley, chiefly regarding its Flora. *Journ. As. Soc. Beng.*, vol. xxxii, pp. 219-266. [1863.]
7401. **Stewart, P. C. A.** Notes on the Roumanian Oil-Fields. *Trans. Amer. Inst. Min. Eng.*, vol. xxxvii, pp. 333-338. [1907.]
7402. ——— The Malkop Oilfield, South Russia. *Eng. Min. Journ.*, vol. xci, pp. 424-426. [1911.]
7403. **Stigand, J. A.** Petroleum in Japan. *Journ. Soc. Arts*, vol. liv, pp. 913-919. [1906.]
7404. **Stigand, W.** Report for the years 1886, 1888, 1890 on the Trade of Sicily. *Dipl. Cons. Rep.*, ann. ser., nos. 239, 576, 949. [1887, 1889, 1891.]
7405. ——— Report on the Production of Sulphur and other Minerals in Sicily. *Ibid.*, misc. ser., no. 112. [1888.]
7406. ——— Report for 1892 on the Trade of the Philippine Islands. *Ibid.*, ann. ser., no. 1289. [1893.]
7407. **Stillman, H.** Locomotive Practice in the Use of Fuel Oils. *Trans. Amer. Soc. Mech. Eng.*, vol. xxxiii, pp. 887-896. [1911.]
7408. **Stillman, T. B.** [Asphalt, its Occurrence, Composition, Technical Applications and Methods of Analysis.] *Stevens Inst. Indic.*, vol. xxi, pp. 389-397. [1905.]
7409. **Stilz, H. B.** Suggestion for a Fuel Oil Burner. *Power*, vol. xxxii, pp. 166, 167. [1910.]
7410. **Stirling, J.** Notes on the Brown-coal Industry in Germany and Austria. *Rep. Dep. Mines, Victoria*, n.s. no. 1. Pp. 39; 3 pls. [1901.]
7411. **Stirling, B.** The Cost of Oil Production in Baku. *Petrol. Rev.*, vol. vi, pp. 226, 227, 253, 254. [1902.]
7412. ——— An Improved Appliance for Petroleum Oil-Raising. *Ibid.*, vol. vii, p. 241. [1902.]
- Stockler, M.**, see **Koenig, G. A.**
- Stockings, W. E.**, see **Bone, W. A.**
7413. **Stoddard, J. T.** On the Determination of the Flashing Point of Petroleum. *Amer. Chem. Journ.*, vol. iv, pp. 285-288; vol. vi, pp. 18-23. [1882, 1884.]
7414. **Stöhr, E.** Schiarimenti intorno alla carte delle salse e delle località oleifere di Monte Giblo. *Ann. Soc. Nat. Modena*, t. ii, pp. 169-178. [1867.]
7415. ——— Das Pyrospissit-Vorkommen in der Braunkohlen bei Weissenfels und Zeitz (Preussische Provinz Sachsen). *N. Jahrb.*, 1867, pp. 403-428, pl. iv.
7416. ——— Intorno agli strati terziari superiori di Montegibbio e vicinanze. *Ann. Soc. Nat. Modena*, vol. iv, pp. 271-281. [1869.]
7417. **Stök, H. H.** Beaumont Oil-field (Tex.). *Mines and Minerals*, vol. xxiii, pp. 490-492. [1903.]
7418. **Stoess, P. C.** The Kayak Coal and Oil Fields of Alaska. *Min. Sci. Press*, vol. lxxxvii, p. 65. [1903.]
7419. **Stohmann, F.** Die Verbrennungswärme organischer Verbindungen. *Zeitschr. physik. Chem.*, bd. vi, pp. 334-357. [1890.]
7420. **Stokes, A. H.** Economic Geology of Derbyshire. *Trans. Chesterfield Inst. Eng.*, vol. vi. [1878.]
7421. **Stokes, H. N.** On a Petroleum from Cuba. *Bull. U.S. Geol. Surv.*, no. 78, pp. 98-104. [1891.]
7422. ——— Petroleum from Cuba. *Eng. Min. Journ.*, vol. lxxiii, p. 347. [1902.]
7423. **Stolba, F.** Das Paraffin. *Zita*, kn. x, pp. 184-186. [1862.]
7424. ——— Anwendung des Paraffins zu gewissen Crystallisationsversuchen. *Journ. prakt. Chem.*, bd. xcix, p. 53. [1866.]
7425. ——— Nothwendige Vorlicht bei Anwendung des Paraffins im das Uebersteigen kochender Flüssigkeiten zu verhindern. *Abh. k. böhm. Ges. Wiss.*, f. 6, bd. iv. [1870.]
7426. ——— Reinigung der mit Petroleum verunreinigten Glasgefässe. *Polyt. Journ.*, bd. ccl, pp. 148, 149. [1871.]
7427. ——— [Ozokerit, Anthracite and Petroleum in Cavities in Silurian Limestone.] *Sitz. k. böhm. Ges. Wiss.*, 1880, p. 129.
7428. **Stoller, J.** Die Erdöllagerstätten von Borsywal-Tustanowice. *Petroleum Zeitschr.*, bd. v, pp. 11-14. [1909.]
7429. **Stolzinger, K.** Technische Prüfung der Schmieröle. *Chem. Rev. Fett-Harz-Ind.*, bd. xiv, pp. 239-242, 274-277. [1907.]

7430. **Stone, F. W.** Natural Gas as a Factor in the Artificial Gas Business [Ohio Gas Assoc.]. *Amer. Gas Light Journ.*, vol. lxxviii, pp. 570, 571, 602-605. [1903.]
7431. ——— Increasing the sales of gas for domestic purposes. *Nat. Gas Journ.*, vol. 1, no. 8, pp. 4-6. [1907.]
7432. **Stone, G. H.** Note on the Asphaltum of Utah and Colorado. *Amer. Journ.*, ser. 3, vol. xlii, pp. 148-159. [1891.]
7433. **Stone, R. W.** Oil and Gas Fields of Eastern Greene County, Pennsylvania. *Bull. U.S. Geol. Surv.*, no. 225, pp. 396-413. [1904.]
7434. ——— Mineral Resources of the Elders-Ridge Quadrangle, Pennsylvania. *Ibid.*, no. 256. Pp. 86, 12 pls. [1905.]
7435. ——— Waynesburg, Penn. Fo. 121, *U.S. Geol. Surv.*, 1905.
7436. ——— Elders Ridge, Pa. Fo. 123, *Ibid.*, 1906.
7437. **Stone, R. W., and F. G. Clapp.** Geology of Oil and Gas Fields of Greene County (Pa.). *Bull. U.S. Geol. Surv.*, no. 304, pp. 110, 3 pls. [1907.]
7438. **Stoop, A.** Rapport over de Petroleum-Industrie in Noord-Amerika. *Jaarb. Mijns. Ned. O.-Ind.*, jg. xvii, Techn., pp. 5-273, 25 pls. [1888.]
7439. **Stoppani, A.** Saggio di una Storia naturale dei Petrolii. *Rend. R. Ist. Lomb.*, t. 1, pp. 262-271. [1864.]
7440. ——— I Petrolii in Italia. *Politecnico*, ser. 4, vol. 1, Lett. Sci., pp. 77-93, 219-230, 574-586, 709-720; vol. 2, pp. 63-84, 216-228. [1866.]
7441. ——— Corso di Geologia. 3 Tt. 8vo, Milan, 1871-1873.
7442. **Stoppelaar, L. P. de.** De Petroleum Industrie in het bijzonder der van Nederlandsch Oost-Indie. 8vo, Amsterdam, 1897.
7443. **Storch, L.** Ein Vorschlag zum qualitativen und quantitativen Nachweis von Harzölen in Mineral-schmieröl. *Ber. österr. Ges. chem. Ind.*, vol. ix, pp. 93-95. [1887.]
7444. **Storer, F. H., see Warren, C. M.**
7444. **Stowell, S. H.** Petroleum. *Min. Res. United States for 1882*, pp. 186-212. [1883.]
7445. ——— Petroleum. *Ibid. for 1883 and 1884*, pp. 214-232. [1885.]
7446. ——— Natural Gas. *Ibid.*, pp. 233-245. [1885.]
7447. **Straeciati, E., see Bartoll, A.**
7447. **Strache, H.** Der gegenwärtige Stand des Beleuchtungswesens. *Compt. Rend. Congr. internat. Chim. appl.*, sess. 3, t. iii, pp. 43-48. [1890.]
7448. **Strakovski, —.** [On the Western Shore of the Caspian Sea. The Condition of Armenia, Persia, etc. Oil-wells. Photogen Industry of Surakhani.] *Russk. Viedom.*, 1866, pp. 484-511.
7449. **Strangways, W. T. H. F.** An Outline of the Geology of Russia. *Trans. Geol. Soc.*, ser. 2, t. 1, pp. 1-39. [1822.]
7450. **Stransky, S.** Die Feuerversicherung bei der Verwendung Mineralölhaltiger Spicköle. *Chem. Rev. Fett-Harz-Ind.*, bd. v, pp. 193-195. [1898.]
7451. ——— Der Flammpunkt des Petroleums. *Ibid.*, pp. 229-233. [1898.]
7452. ——— Erscheint es heute noch gerechtfertigt, wenn die Versicherungsgesellschaften fordern, dass Spicköle (Elaïne, Walfalme, etc.) nicht mehr als 15 Prozent mineralölarthige Bestandtheile enthalten dürfen, wenn keine höhere Versicherungsprämie eingehoben werden soll? *Compt. Rend. Congr. internat. Chim. appl.*, sess. 3, t. 1, pp. 261-264. [1899.]
7453. ——— Das Ragozin-Destillationsverfahren. *Chem. Rev. Fett-Harz-Ind.*, bd. vii, pp. 68-73, 89-94, 109-113. [1900.]
7454. **Stransky, S., and C. A. Lobry de Bruyn.** Durch welche Massregeln wäre zu bewirken, dass bei der Anwendung des Petroleums als Leuchtöl die persönliche Sicherheit nicht beeinträchtigt, bezw. das Feuergefährlichkeits-minimum ohne Verlust an Leuchtkraft erzielt werde? *Compt. Rend. Congr. internat. Chim. appl.*, sess. 3, t. iii, pp. 19-31. [1899.]
- Strasser, L., see Bamberger, E.**
- Strasser, R., see Donath, E.**
7455. **Strauss, J.** Ueber wasserlösliche Oele. *Sci. enstied-Zeit.*, bd. xxxi, pp. 777, 801, 840. [1904.]
- Streak, W. H., see Blatchley, W. S.**
7456. **Strecker, A.** Beiträge zur Bestimmung des specifischen Gewichtes flüssiger Körper. *Rep. Pharm.*, bd. xxv, pp. 422-426. [1827.]
7457. **Streeter, R. L.** The Internal-combustion Engine in Modern Practice. *Eng. Mag.*, vol. xlii, pp. 57-74, 185-205, 349-370. [1911.]
7458. **Stremme, H.** Zur Frage der Eigenwärme bituminöser Gesteine. *Zeitschr. deutsch. geol. Ges.*, bd. lvi, Br. M., pp. 183-198. [1905.]
7459. ——— Das Erdöl und seine Entstehung. 8vo, Leipzig, 1906.
7460. ——— Ueber die Bitumenlerung. *Monatsh. deutsch. geol. Ges.*, 1907, pp. 153-164.
7461. ——— Das polymerisierende Erdöl als Wärmequelle im Erdboden. *Centralbl. Min.*, 1908, pp. 271-276.
7462. **Stremme, H., and F. Spate.** Die Verwitterung von brennbaren organischen Gesteine (Kautstobliithe). *Zeitschr. angew. Chem.*, bd. xx, pp. 1841-1844. [1907.]
7463. **Strickland, F.** A Manual of Petrol Motors and Motor Cars, comprising the Designing, Construction, and Working of Petrol Motors. 8vo, London, 1907.
7464. **Strickland, H. E.** On the Geology of the Island of Zante. *Trans. Geol. Soc.*, ser. 2, vol. v, pp. 403-408, pl. xxxiii. [1840.]
7465. **Strijov, I. N.** [Geology of North-eastern Daghestan.] *Neph. Dielo*, 1901.
7466. ——— [Grozni Oil Field.] *Gorn. Journ.*, 1903, t. 1, pp. 76-84.
7467. ——— [Researches in Tcheleken Island, and a new variety of Petroleum there.] *Ibid.*, t. 3, pp. 250-260. [1903.]
7468. ——— [Structure of the Grozni Oil Field.] *Ibid.*, 1905, t. 1, pp. 383-390, pl.
7469. ——— The Oil Fields of Grosny. *Petrol. Rev.*, vol. xxii, pp. 267-269. [1910.]
7470. ——— The White Oil of Grosney. *Ibid.*, pp. 303-306. [1910.]
7471. **Strippelmann, F. E.** Versuche mit Abschwähung von Braunkohlen und Anwendung des erhaltenen Products zu Kleinfenerarbeiten, angestellt auf dem Braunkohlenwerke am Haibtschwalde del Cassel. *Stund. Güting. Ver. bergm. Freund.*, bd. ii, pp. 169-194. [1828.]
7472. **Strippelmann, L.** Bergmännisch-technisches Gutachten, betreffend die Petroleum- und Steinsalzfundee in der norddeutschen Ebene (Allergebiet), mit specieller Berücksichtigung der gleichnamigen Mineralfunde bei Steinförde und Wietze. *Gornitz*, 1877.
7473. ——— Beitrag zur Geschichte des Petroleums. *Berg-Hütt. Zeit.*, bd. xxxviii, p. 349. [1879.]
7474. ——— Die Petroleum-Industrie Oesterreichs-Deutschlands, dargestellt zur Klarstellung deren Wichtigkeit und Zukunft und zur Aufklärung des, für diese Industrie sich interessirenden Kapital's in geschichtlicher, geologisch-bergmännischer, wirtschaftlicher und technischer Beziehung. 3 Bde. 8vo, Leipzig, 1878-1879.
7475. ——— Petroleum-Fundpunkte in den Vorbergen der Bayerischen Alpen, auf der West- und Ostseite des Tegernsee's Oberbayern. *Oesterr. Zeitschr. Berg-Hütt.*, bd. xl, pp. 439-442. [1881.]
- Strippelmann, L., see Engler, C.**
7476. **Strjemeski, B. I.** [Petroleum Illumination for Workshops, Platforms, and Carriages.] *Zap. Imp. Russk. Tekhn. Obsch.*, g. xxi, v. xl, pp. 35-45, 1 pl. [1887.]
7477. **Strögel, J. C.** De Petroleo. 4to, 1879.
7478. **Strombeck, A. v.** Der obere Lias und braune Jura bei Braunschweig. *Zeitschr. deutsch. geol. Ges.*, bd. v, pp. 81-222. [1853.]
7479. ——— Ueber den Gault bei den Frankenmilhe unweit Ahaus. *Verh. nat. Ver. preuss. Rheinl. Westph.*, bd. xv, pp. 443-450. [1855.]



7480. **Strombeck, A. v.** Ueber ein Vorkommen von Asphalt im Herzogthume Braunschweig. *Zeitschr. deutsch. geol. Ges.*, bd. xxiii, pp. 277-288. [1871.]
7481. ——— In welchen Schichten ist Petroleum im nordwestlichen Deutschland zu suchen. *Braunschv. Anz.*, 1881, p. 1997.
7482. **Stromeyer, F.** Ueber den Scheererit und das Vorkommen des Broms. *Arch. ges. Nat.*, bd. x, pp. 113-117. [1827.]
7483. **Strong, R. M.** Commercial Deductions from Comparisons of Gasoline and Alcohol Tests on Internal-Combustion Engines. *Bull. U.S. Geol. Surv.*, no. 392. Pp. 38. [1909.]
7484. **Strother, D. H.** Mexican Asphaltum. *Rep. Cons. U.S.*, vol. ix, pp. 141-143. [1883.]
7485. **Strother-Smith, W.** Comparative Performances of Oil-Burning Torpedo-Boat Destroyers on Trials, with some Observations on Oil Burning. *Journ. Amer. Soc. Naval Eng.*, vol. xxiii, pp. 412-414. [1911.]
7486. **Strover, G. A.** Memorandum on the Metals and Minerals of Upper Burma. *Geol. Mag.*, dec. i, vol. x, pp. 356-361. [1873.]
7487. **Struckmann, C.** Die Portland-Bildungen der Umgegend von Hannover. *Zeitschr. deutsch. geol. Ges.*, bd. xxxix, pp. 32-67, pls. iv-vii. [1887.]
7488. **Strumpf, E.** [The Naphtha Region, Baku.] *Wszeczwiat*, 1895, nos. 44, 45.
7489. **Struthers, J.** Asphaltum and Bituminous Rock. *Min. Res. U.S.*, 1901, 1902. [1902, 1904.]
7490. **Strzelbicki, A.** Notizen über das Bergöl in Galizien. *Oesterr. Zeitschr. Berg-Hütt.*, bd. xvii, pp. 249-252. [1869.]
7491. ——— Bergölgewinnung in Bobrka bei Krosno in Galizien. *Ibid.*, bd. xviii, pp. 37-39, 44, 45. [1870.]
7492. **Strzelecki, P. E. de.** [List of Minerals of New South Wales]; being appendix to report of Governor Gipps. *Sydney*, 1840.
7493. ——— Physical Description of New South Wales and Van Diemen's Land. 1845.
7494. **Strzetelski, J.** Aus dem Kaukasus. *Naphta*, bd. x, pp. 321-323. [1902.]
7495. ——— Die Naphtaindustrie in Grosnyj. *Naphta*, bd. xvi, pp. 273-275, 291-294. [1908.]
7496. **Stuart, M.** Geology and Prospects of Oil in Western Promé and Kama, Lower Burma (including Namanay, Padaung, Taungbogyi, and Zlaing). *Rec. Geol. Surv. Ind.*, vol. xxxvii, pp. 259-270, pl. xxiii. [1910.]
7497. ——— The Recorrelation of the Pegu System in Burma, with Notes on the Horizon of the Oil-bearing Strata (including the Geology of Padankpin, Banbyin and Aukmanein). *Ibid.*, pp. 271-291, pl. xxiv. [1910.]
7498. ——— The Sedimentary Deposition of Oil. *Ibid.*, vol. xl, pp. 320-333. [1910.]
7499. **Stuart-Menteath, P. W.** Sur la Géologie du Département des Landes. *Bull. Soc. Géol. France*, sér. 3, t. xxiv, pp. 301-310. [1896.]
7500. **Studer, T.** Forschungsreise S.M.S. Gazelle in den Jahren 1874 bis 1876. Th. III. Zoologie und Geologie. *Berlin*, 1889.
7501. **Stur, D.** Die Neogen-tertiären Ablagerungen von West-Slavonien. *Jahrb. k.-k. geol. Reichs.*, bd. xii, pp. 285-299. [1862.]
7502. **Sturdza, D.** Die Petroleumfrage in Rumänien. *Petroleum Zeitschrift*, bd. i, pp. 177-180, 216-219, 251-254, 293-296. [1905, 1906.]
7503. **Suess, E.** Ueber böhmischen Graptolithen. *Nat. Abhandl.*, bd. iv, abth. 4, pp. 87-134. [1851.]
7504. **Sulimirski, W.** Einiges über den Excoenterbohrer. *Naphta*, bd. x, pp. 7, 8. [1902.]
7505. **Sulzer, G.** Umbau eines Personendampfbotes auf dem Zürichsee für Dieselmotorenbetrieb. *Zeitschr. Ver. deutsch. Ing.*, bd. liv, pp. 553-556. [1910.]
7506. **Sumner, O.** Marine Petrol Engines and Motor Launches. *Trans. Inst. Marine Eng.*, vol. xv, no. 14, pp. 70. [1904.]
7507. **Suplee, H. H.** Historical Review of the Development of the Internal Combustion Engine. *Cassier's Mag.*, vol. xxxiii, pp. 3-22. [1907.]
7508. **Surjitski, S.** [Thermal Study of the Martin Oil-furnace.] *Gorn. Journ.*, 1901, t. 3, pp. 79-127.
7509. **Surr, G.** Conditions favourable for Petroleum Prospecting. *Mining World*, vol. xxxiii, pp. 227, 228. [1910.]
7510. ——— Some Notes on the History of Petroleum. *Ibid.* [1910.]
7511. ——— The Origin of Petroleum. *Los Angeles, Mining Rev.*, vol. xxviii, pp. 17, 18. [1910.]
7512. **Süssmann, L.** Ueber Oelfeuerung für Lokomotiven. *Ann. Geverbe Bauw.*, bd. lxvi, pp. 234-237; bd. lxvii, pp. 12-16. [1910.]
7513. **Szaszyczy, Z.** [Deposits of Sulphur, Petroleum and Ozokerite at Dzwiniacz, with Remarks on the Origin of Petroleum.] *Sprawozd. Kom. Fizyogr. Krakow*, t. x, pp. 171-179. [1876.]
7514. **Sutherland, D. A.** On Paraffin Scale Testing. *Journ. Soc. Chem. Ind.*, vol. vii, pp. 123-126, 271-276. [1887.]
7515. ——— The Petroleum Industry of Rumania. *Petrol. Rev.*, vol. i, pp. 95-101, 131-137, pl. and map. [1899.]
7516. ——— On the Oil Industries of Canada and the United States. *Ibid.*, vol. vi, pp. 633-636, 661-665. [1902.]
7517. ——— Bitumen in Insulating Compositions. [Read before the Faraday Society, 8th Dec. 1903.] *India-Rubber Journ.*, vol. xxvii, pp. 111-113, 157, 158, 207. [1904.]
7518. **Sutphen, H. R.** High-speed Motor Boats for Pleasure Use. *Trans. Inst. Naval Archit. Eng.*, vol. xv, pp. 97-101. [1907.]
7519. **Suzzi, F.** [Use of Petroleum in examining Oils by the Maumené Test.] *Boll. Chim. Farm.*, t. xlv, pp. 301-308. [1905.]
7520. **Sviatlobsk, V.** [Petroleum Processes from a Sanitary Point of View.] *St. Petersburg*, 1893.
7521. **Svoitsov, —.** [Illuminant Oil Gas at Kazan.] *Zdorov*, 1874, t. i, pp. 580, 604.
7522. **Swallow, G. C.** Report on the Geological Survey of Miami County, Kansas. *Kansas City*, 1865.
7523. **Sweet, E. T.** On Kerosene Oil. *Trans. Wisconsin Ac.*, vol. liii, pp. 77-83. [1876.]
7524. **Swierczewski, —.** [Flush-drilling in undeveloped fields.] *Kopa*, 1911, no. 8.
7525. **Swoboda, J.** Die Entwicklung der Petroleumindustrie in volkswirtschaftlicher Beleuchtung. *Tübingen*, 1895.
7526. ——— Der Asphalt und seine Verwendung. 8vo, *Leipzig*, 1905.
7527. ——— Ueber den Ursprung des Erdöls. *Petroleum Zeitschr.*, bd. i, pp. 209-212. [1906.]
7528. **Sykes, C. P.** Petroleum in Colorado Territory. *New York*, 1865.
7529. **Sylvester, G. E.** Gasoline Motor Haulage. *Mines and Minerals*, vol. xxxi, pp. 629, 630. [1911.]
7530. **Symes, M. A.** An Account of an Embassy to the Kingdom of Ava, sent by the Governor-General of India in the year 1795. 3 vols. 8vo, *London*, 1800.
7531. ——— Brief Account of the Religion and Civil Institutions of the Burmans; and a description of the Kingdom of Assam, to which is added an account of the Petroleum Wells in the Burma Dominions, extracted from a Journal, from Rangoon up the River Erawaddy to Amarapoorah, the present capital of the Burmah Empire. 8vo, *Calcutta*, 1826.
7532. **Szniwski, V.** Ueber die Verdampfungswärme einiger Fractionen des Erdöles von Kleczany (Galizien). *Zeitschr. angew. Chem.*, bd. xl, p. 621. [1898.]
7533. **Szyrkín, N.** Ueber Naphta im Kaukasus. *Berg-Hütt. Zeit.*, bd. li, pp. 287-289. [1892.]
7534. ——— Neues aus dem Kaukasus. *Ibid.*, pp. 427, 428. [1892.]
7535. **Szyroczynski, L.** [Petroleum and Ozokerite Mining at Boryslaw.] *Kosmos*, t. vi, pp. 210-213. [1881.]
7536. ——— [Explanation of the Geological Map of Petroleum and Ozokerite Discoveries in Galicia in 1881.] *Ibid.*, t. ix, pp. 22-25. [1884.]

7537. **Syroczyński, L.** [Advantage of Scientific Study to the Petroleum Industry in Galicia.] *Kosmos*, t. ix, pp. 580-592. [1884.]
7538. ——— Exposition universelle d'Anvers, 1885. Le Pétrole et la Cire Minérale. *Rev. Univ. Mines*, sér. 2, t. xviii, pp. 1-19, pl. 1. [1885.]
7539. ——— La production du pétrole et de la cire minérale en Autriche. *Rev. Univ. Mines*, sér. 3, t. iv, pp. 178-183. [1888.]
7540. ——— Note sur le forage canadien et son application à l'exploration du pétrole en Galicie. *Paris*, 1889.
7541. **Szadeczyk, J. v.** Erdgas im siebenbürgischen Tertiarbecken. *Petroleum Zeitschr.*, bd. vi, p. 773. [1911.]
7542. **Szajnocha, L. W.** Vorlage der geologischen Karte der Gegend von Gorlice. *Verh. k.-k. geol. Reichs.*, 1880, pp. 304-309.
7543. ——— Das Petroleumvorkommen von Sloboda Rungurska. *Ibid.*, 1881, pp. 162-165.
7544. ——— Vorlage der geologische Karte der Gegend von Jaslo und Krosno in West Galizien. *Ibid.*, pp. 342-346.
7545. ——— [Mineralogy of Petroleum in Galicia.] *Museum (Cracow)*, 1881.
7546. ——— [Galician Mining in Krakow Exhibition, 1887.] 8vo, *Lemberg*, 1888.
7547. ——— [The Mineral Products of Galicia.] *Lemberg*, 1894.
7548. ——— Erläuterungen zur VI Lieferungen des geologischen Atlas von Galizien. *Cracow*, 1896.
7549. ——— Ueber die Entstehung des karpathischen Erdöls. *Naphta*, 1899.
7550. ——— [Occurrence of Petroleum at Wojcza, Poland.] *Rozpr. Ak. Umiej. Krakow*, t. xlii, B, pp. 236-244. [1902.]
7551. ——— Ueberhitzer Dampf für die Rohölgruben. *Naphta*, bd. xii, pp. 17-19. [1904.]
7552. ——— The Petroleum Industry of Galicia. *Petroleum World*, vol. ii, pp. 640, 641. [1905.]
7553. ——— Das Erdölvorkommen in Galizien im Lichte neuer Erfahrungen. *Petroleum Zeitschr.*, bd. vi, pp. 537-543. [1911.]
7554. **Szilagyi, I.** [Description of Marmaros County.] [1876.]
7555. **Szirmai, J.** [On the Körösmező Oil-field.] *Termész. Közl.*, köt. xx, pp. 235-238. [1888.]
7556. **Szoutagh, T. v.** Geologische Studien in der Umgebung von Nagy-Károly, Erendred, Margitta, und Szalard. *Jahresb. k. ung. geol. Anst.*, 1888, pp. 62-71. [1890.]
7557. ——— [Asphalt bed in Bihar Co., Hungary.] *Banyasz. Kohasz. Lapok*, erf. xxx, p. 248. [1897.]
7558. **Szujski, W.** Die Entwicklung von Tustanowiec. *Petroleum Zeitschr.*, bd. i, pp. 51-53. [1905.]
7559. **T** ——— Le Pétrole en Perse. *Journ. Pét.*, t. x, p. 286. [1910.]
7560. **T** ——— Ueber echten Asphalt. *Rombreg's Zeit. prakt. Baukunst*, bd. xxxix, p. 195. [1879.]
7561. **T** ——— R. Neuer Petroleum Destillierkessel, System Jos. Popelka. *Chem. Rev. Fett-Harz-Ind.*, bd. i, no. 14, pp. 1, 2. [1895.]
7562. **T** ——— R. C. N. The Apostalake Oil Field, Roumania. *Petrol. World*, vol. vii, pp. 519, 520. [1910.]
7563. **Tabernaemontanus, J. D.** [Jacob Theodorus, of Berg-Zabern.] Neuer Wasserschatz, d. i. von allen metallischen mineralischen Bädern und Wassern. *Frankfurt*, 1544.
7564. **Tachon, A.** "Oil Fuel." *Journ. Pét.*, t. vi, pp. 381-385. [1906.]
7565. **Tacit, Vergile.** [Berca-Pacalele Oil Field, Roumania.] *Monit. Int. Pétrol. Roum.*, t. ii, pp. 497-500. [1901.]
7566. ——— Regiunea petrolifera din Valcea. *Ibid.*, 1901.
- Tacit, V.**, see **Tanasescu, J.**
7567. **Taff, J. A.** Albertite-like Asphalt in the Choctaw Nation, Indian Territory. *Amer. Journ.*, ser. 4, vol. viii, pp. 219-224, map. [1899.]
7568. **Taff, J. A.** Tishomingo (Ind. Terr.). *Fo 98, U.S. Geol. Survey*, 1904.
7569. ——— Description of the unleased segregated asphalt lands in the Chickasaw Nation, Indian Territory. *U.S. Dept. Int. Circ.*, 1904, no. 6. Pp. 14.
7570. ——— Muscogee. *Fo 132, U.S. Geol. Surv.*, 1906.
7571. ——— Asphalt and Bituminous Rock. *Min. Res. U.S.*, 1906-1908 [1907-1909].
7572. ——— Grahamite Deposits of South-eastern Oklahoma. *Bull. U.S. Geol. Surv.*, no. 380, pp. 286-298, pl. xxiii. [1909.]
7573. **Taff, J. A.**, and **W. J. Reed.** The Madill Oil Pool, Oklahoma. *Ibid.*, no. 381, pp. 504-513. [1910.]
7574. **Taff, J. A.**, and **M. K. Shaler.** Notes on the Geology of the Muscogee Oil Field. *Ibid.*, no. 260, pp. 441-445. [1905.]
7575. **Taff, J. A.**, and **C. D. Smith.** Ozokerite Deposits in Utah. *Ibid.*, no. 285, pp. 369-372. 1906.
7576. **Tager, von.** Ueber den natürlichen Gegenstand [Naphta-Quellen bei Baku]. *Schr. Russ. K. Ges. Min.*, bd. i, pp. 250-252. [1842.]
7577. **Tagliabue, J.** Specific Gravity of Coal Oils, and how the Test may be applied. *Amer. Min. Gaz.*, vol. i, pp. 166-169. [1864.]
- Tait, D.**, see **Crampton, C. R.**
7578. **Tait, J. L.** Gas Well at San Antonio. *Geol. Sci. Bull.*, vol. i. [1889.]
7579. **Takano, Shinichi.** The Petroleum Industry of Japan. *Petrol. Gazette (Pittsburgh)*; *Petr. Rev.*, vol. i, pp. 446, 475, 476. [1900.]
7580. ——— The Development of the Japanese Oil Industry. *Petrol. Rev.*, vol. iii, p. 75. [1900.]
7581. ——— On the Chemistry of the Japanese Petroleum. *1st Internat. Petrol. Congr.*, pp. 53-60, 69-74. [1900.]
- Takano, S.**, see **Mabery, C. F.**
7582. **Talbot, A. C.** Report for 1891, 1892 on the Trade of Bushire. *Dipl. Cons. Rep.*, ann. ser., nos. 1092, 1252. [1892, 1893.]
7583. **Talbot, C. A. P.** Report for 1889, 1890 on the Trade of Taganrog. *Ibid.*, ann. ser., nos. 675, 841. [1890, 1891.]
7584. **Talbot, F. A.** New [Leinweber] Method of extracting Oil from Boreholes. *Eng. Min. Journ.*, vol. lxxxvii, pp. 1001-1003; vol. lxxxix, pp. 1270, 1271. [1909, 1910.]
- Talbot, H. J.**, see **Binney, E. W.**
7585. **Talbot, H. W.** The Burning Gas Well at Caney, Kansas. *Eng. Min. Journ.*, vol. lxxxii, p. 945. [1906.]
- Tallmon, M. C.**, see **Morgan, W. C.**
7586. **Tanasescu, I.** Rumänisches Erdöl. *Oesterr. Zeitschr. Berg-Hütt.*, bd. xlviij, pp. 427-430. [1900.]
7587. **Tanasescu, I.**, and **V. Tacit.** L'Exploitation du Pétrole en Roumanie. *Bucharest*, 1907.
7588. ——— Le Sondage hydraulique. *Compt. Rend. Congr. internat. Pétrole*, sess. 3, t. ii, pp. 417-438. [1910.]
- Tanasescu, I.**, see **Edeleanu, L.**
7589. **Taramelli, T.** Sul recente Rinvenimento di abbondanti Fonti petrolifere a Salsomaggiore. *Rend. R. Ist. Lomb.*, ser. 3, t. xxx, pp. 786-796. [1897.]
7590. **Tarbutt, P. F.** Liquid Fuel. *Trans. Soc. Eng.*, 1886, pp. 193-216, 1 pl.
7591. **Tardin, J.** Histoire naturelle de la fontaine qui brule près de Grenoble. *Tournon*, 1618.
7592. **Tarleton, C. H.** Mine Explosions from Natural Gas Well. Description of Two Explosions that were caused by Gas escaping from a Well into Mines. *Mines and Minerals*, vol. xxxiii, pp. 15-18. [1911.]
7593. **Tarr, P. S.** The Yakutat Bay Region. *Bull. U.S. Geol. Surv.*, no. 284, pp. 61-64. [1906.]
7594. **Tassart, L. C.** Sur la Relation qui existe entre la Distribution des Régions Pétrolières et la Répartition des Zones Séismiques. *Compt. Rend.*, t. cxiv, pp. 490, 491. [1907.]

7595. **Tassart, L. C.** Exploitation du Pétrole. Historique, Extraction, Sondages, Géographie et Géologie, Recherches des Gîtes, Exploitation des Gisements, Chimie, Théories de la Formation. 8vo, Paris, 1908.
7596. **Tassilly, E.** L'Industrie du Pétrole en Roumanie. *Rev. Sci.*, t. xlviii, pp. 225-237. [1910.]
7597. **Tassilly, E.**, see **Calvet**, —.
7598. **Tate, A. N.** On the Exploibility of Petroleum Oil. *Pharm. Journ. Trans.*, ser. 2, vol. iv, pp. 150, 151. [1862.]
7598. — Petroleum and its Products: an account of the history, origin, composition, properties, uses, etc., of Petroleum. 8vo, London, 1863.
7599. — The Products of the Distillation of Cannel Coal. *Pharm. Journ.*, ser. 2, vol. viii, pp. 585-587. [1867.]
7600. — The Examination of Petroleum and other Mineral Oils, according to the Petroleum Act, 1868. 8vo, London, 1869.
7601. — The Origin of Petroleum and other Natural Hydrocarbons. *Proc. Liverpool Geol. Soc.*, vol. v, pp. 160-168. [1886.]
7602. **Tate, R.** Geology in its relation to Mining and Subterranean Water Supply in South Australia. *Trans. R. Soc. S. Australia*, vol. iv, pp. 113-134. [1882.]
7603. **Tate, Thomas.** Notes on Recent Borings for Salt and Coal in the Tees District. *Quart. Journ. Geol. Soc.*, vol. xlviii, pp. 488-495. [1892.]
7604. **Taube, J.** Beiträge zur Naturkunde des Herzogthums Celle und Luneburg-Celle. 2 Bde. 8vo, Celle, 1766, 1769.
7605. **Taubes-Bárladu, S.** Die Erdölquellen Rumäniens. *Zeitschr. angew. Chem.*, bd. ii, pp. 605, 606. [1889.]
7606. **Tawildarow, N.** Ueber einen neuen Kohlenwasserstoff aus Theeröl. *Zeitschr. Chem.*, f. 2, bd. iv, pp. 278, 279. [1868.]
7607. **Taylor, J.** Mineral Map and General Statistics of New South Wales. 8vo, Sydney, 1876.
7608. **Taylor, Andrew.** Sketch of the Geology of the Torbane Mineral Field. *Geologist*, vol. v, pp. 43-47. [1862.]
7609. — On the Bituminous Shales of Linlithgowshire and Edinburghshire. *Proc. R. Phys. Soc. Edinb.*, vol. iii, pp. 16-24. [1867.]
7610. — Scotch and Welsh Mineral-Oil Trades. *Trans. Edinb. Geol. Soc.*, vol. i, pp. 19, 20. [1868.]
7611. — On Bitumen, Oil-shales and Oil-coals. *Ibid.*, vol. ii, pp. 187-189. [1873.]
7612. — On the Nomenclature of the Hydrocarbon Compounds, with a Suggestion for a New Classification. *Min. Mag.*, vol. vii, pp. 13-17. [1886.]
7613. **Taylor, C. M.** Treating Timber with Crude Petroleum. *Chem. Eng.*, vol. xi, pp. 35, 36. [1910.]
7614. **Taylor, R. C.** Statistics of Coal. The Geographical and Geological Distribution of Fossil Fuel, etc. 8vo, Philadelphia, 1848.
7615. — Deposition respecting the Asphaltum Mine at Hillsborough, New Brunswick (*Re Abraham Gesner v. Halifax Gaslight Co.*). 8vo, Philadelphia, 1851.
7616. — On a Vein of Asphaltum at Hillsborough in Albert County, Province of New Brunswick. *Proc. Amer. Phil. Soc.*, vol. v, pp. 241-243. [1854.]
7617. **Taylor, R. C.**, and **T. G. Clemson.** Notice of a Vein of Bituminous Coal [Asphalt], recently explored in the Vicinity of the Havana, in the Island of Cuba. *Trans. Amer. Phil. Soc.*, vol. vi, pp. 191-196. [1837.]
7618. **Taylor, V.** [Poisoning by Lamp-gas.] *Zdorov, t. 1*, p. 168. [1874.]
7618. **Taylor, W.**, see **McCalley, H.**
7619. **Tchaikovski, N.** [Oil Gas Illumination of the Riasan Stations on the Riasan-Koslov Railway.] *Journ. Minist. Put. Soobshch.*, 1879, t. iii, pp. 72-75.
7620. **Tcharnotzki, S. I.** [Geological Researches in the Kuban Oil Region, Nephthyannaya-Schirvanskaya.] *Mém. Com. géol. Russ.*, n. s., livr. 47 Pp. 72, map. [1909.]
7621. **Tcharnotzki, S. I.**, and **I. M. Gubkin.** [Report on Operations in the Nephthyannaya-Schirvan ("Mal'kop") Oilfield.] *Bull. Com. géol. Russ.*, t. xxix, pp. 1-36, pls. 1-11. [1910.]
7622. **Tchernischev, T. N.** [Report of the Senior Geologist on the reasons of the urgent request of the Governor of Archangel for a Geological Survey of the Petchora Region.] *Bull. Com. géol. Russ.*, t. vii, Journ., pp. 129-133. [1888.]
7623. — [Mineral Wealth of North Russia.] *Gorn. Journ.*, 1889, t. 2, pp. 116-122.
7624. — [Geological Exploration of the Timan.] *Bull. Com. Géol. Russe*, t. ix, pp. 41-84. [1891.]
7625. **Tchernov, A. A.** Ueber die geologischen Lagerungsverhältnisse des Erdöles im Petchoragebietes. *Ann. géol. Min. Russe*, t. xl, pp. 19-25. [1909.]
7626. **Tchihatchev, P.** Le Pétrole aux États-Unis et en Russie. *Rev. deux Mondes*, t. lxxxix, p. 632. [1888.]
7627. — Études de géographie et d'histoire naturelle. 8vo, Florence, 1890.
7628. **Tchitchibabin, A.** [Trivalent Carbon and the Hexaphenylthane of Ullmann and Borsum.] *Journ. Russk. Fizik. Khim. Obsch.*, t. xxxvii, pp. 109-115. [1905.]
7629. **Tchugav, L. A.** [On Bacteria alleged to live in Petroleum.] *Ibid.*, t. xxxiv, otd. 2, p. 109. [1902.]
7630. — [Remarks on the Origin of Petroleum.] *Ibid.*, t. xxxvi, otd. 1, pp. 453-455. [1904.]
7631. **Tecklenburg, T.** Handbuch der Tiefbohrkunde. 6 Bde. 8vo, Leipzig, 1886-1896.
7632. — Ueber das Auffinden bauwürdiger Petroleumlager. *Organ. Ver. Bohrtechn.*, bd. i, no. 19, pp. 4-9. [1904.]
7633. **Tecklenburg, —.** Ueber Gewinnung elektrischer Energie aus Tiefbohröchern. *Naphtha*, bd. xv, pp. 345-352. [1907.]
7634. **Teclu, N.** Zur Kennzeichnung der Flamme. *Journ. prakt. Chem.*, bd. xlv, p. 246. 1891.
7635. **Teichmann, H.**, and **W. Bross.** Oelfeuerbetriebe mit besonderer Berücksichtigung der Steinkohlenteeröle für Metallschmelzöfen. *Stahl und Eisen*, bd. xxxi, pp. 843-848, 1049-1052. [1911.]
7636. **Tejmann, J. E.** Verslag eener botanische reis over Timor en daardoor ressorterende Eilanden Samaan's Alor, Solor, Floris en Soemba. *Nat. Tijdschr. Ned. Ind.*, dl. xxxiv, pp. 348-517. [1874.]
7637. **Teikh, N.** [History of Taschkent Laboratory.] *Sborn. Statist. Sir-Darya Oblast.*, t. vi, pp. 43-295. [1897.]
7638. **Teisseyre, L.** Geologische Reiseberichte aus der Karpathen Rumaniens (District Bacau). *Verh. k.-k. geol. Reichs.*, 1896, pp. 132-142, 230-253.
7639. — Geologische Untersuchungen im Districte Buzen in Rumänien. *Ibid.*, 1897, pp. 159-166.
7640. — Zur Geologie der Bacauer Karpathen. *Jahrb. k.-k. geol. Reichs.*, bd. xlvii, pp. 567-736, pls. xvi, xvii. [1897.]
7641. — Beiträge zur neogenen Molluskenfauna Rumaniens, mit besonderer Berücksichtigung der Erdölgebiete der Subkarpathen. *An. Inst. geol. Rom.*, t. 1, pp. 215-310, pls. 1-xi. [1907.]
7641. **Teisseyre, L.**, see **Mrazec, L.**
7642. **Teisseyre, W.** Die Schlammluvkanne von Beca-Berca und die Frageörterung der Bedeutung derselben für die Oelzone. *Compt. Rend. Congr. internat. Pétrole*, sess. 3, t. ii, pp. 385-406. [1910.]
7643. **Teleg, L. R. von.** Studien in Erdölführenden Ablagerungen Ungarns. I. Die Umgebung von Zsibo im Comitate Szilagy. *Műth. Jahrb. k.-ung. geol. Anst.*, bd. xl, pp. 259-298, pls. ix, x. [1897.]
7644. — Resultat der Bohrungen auf Petroleum bei Zsibo-Szamos-Udvarhely. *Földt. Köz.*, köt. xxx, pp. 223-227, 246-251. [1900.]
7645. **Teleczinski, A.** [Petroleum and its Use as Commercial and Domestic Fuel.] *Lemberg*, 1870.
7646. **Tello, E.** Descripción de la Provincia de Jujuy. Informes . . . que presenta el Comisionado Provincial a . . . a la Exposición Universal de 1889 en Paris. 8vo, Jujuy, 1888.

7647. **Tenne, C. F. A., and S. Calderon.** Die Mineralfundstätten der Iberischen Halbinsel. 8vo, Berlin, 1902.
7648. **Tenore, G.** Osservazione geologiche sulla catena di monti compresa tra Montecassino ed il fiume Melfa. Naples, 1852.
7649. **Tenore, G.** Raggiugli delle peregrinazione eseguiti sulle montagne del bacino d'Alvito e dei lavori della Commissione per la ricerca delle miniere di ferro nel distretto di Sora. *Ann. Civ. 2 Sicil.*, 1856.
7650. — Sui minerali e rocce utili del 2° Abruzzo Ulteriore, più d'appresso riguardanti le industrie delle miniere e delle costruzioni architettoniche di questa provincia. *Ann. Accad. Aspir. Nat.*, t. iv, pp. 50-63. [1864.]
7651. — La Scienza e l'Arte dell'Ingegneria Architettura. Naples, 1872.
7652. — Saggio sull'industria mineraria e sulla costituzione geologica della Terra di Lavoro, con schema di carta geologica della provincia. Naples, 1872.
7653. — Cenno sull'industria mineraria della Terra di Lavoro. *La Campania (Napoli)*, 1886.
7654. — Priorità di osservazione geologiche ed importanza industriale dei giacimenti petroliferi della valle del Liri nella Terra di Lavoro. *Atti R. Ist. Incorr. Napoli*, ser. 4, vol. ii, no. 4, pp. 10. [1889.]
7655. **Teodorowicz, A.** Ueber die Verwendung der galizischen Petroleumöle zur Herstellung des karburierten Wassergases. *Journ. Gasbeleucht.*, bd. ii, pp. 673-677. [1908.]
7656. **Teploff, —.** Aperçu de la richesse minérale de l'empire Russe. *Ann. Mines*, sér. 3, t. viii, pp. 51-54. [1835.]
7657. **Tergo, C. B.** Geography of Pennsylvania. 1843.
7658. **Terreni, —.** Miniere di Asfalto, Bitume e Petrolio nei Comuni di Manopello, Lettomanopello, Roccamorice, Abbatteggio. Genoa, 1903.
7659. **Terry, S. H., and J. F. Flannery.** The Ventilation of Steamships, with special reference to the removal of explosive and foul gases from Bulk Oil Steamers. *Trans. Inst. Naval Archit.*, vol. xxxvi, pp. 95-104. [1895.]
7660. **Tervet, R.** Sulphur in Shale Naphtha. *Chem. News*, vol. xiv, p. 98. [1882.]
7661. — Note on an Improved Apparatus for the Manufacture of Refined Paraffin Wax. *Journ. Soc. Chem. Ind.*, vol. vi, pp. 355-358. [1887.]
7662. **Testa, L.** Distretto di Caltanissetta. *Riv. Serv. Min.*, 1903, pp. 29-116. [1904.]
7663. **Tetodoux, P., and G. Franche.** Le Graissage Industriel. 8vo, Paris, 1904.
7664. **Thalmann, F.** Die Fette und Oele. 8vo, Vienna, 1881.
- Tharel, A., see Lami, E. O.**
7665. **Thede, —.** Ungarischer Ozokerit. *Pharm. Centralbl.*, bd. xxxi, pp. 81-85. [1890.]
7666. — Wandlungen und Konkurrenzmanöver in der Ceresin-Industrie. *Chem. Ind.*, bd. xxix, pp. 143-147. [1906.]
7667. **Thenius, G.** Untersuchung von Asphaltsteinen aus Tirol, hinsichtlich ihres specifischen Gewichtes, Aschengehaltes, der Theerabtheile, des Photogen-, Asphalt-, und Ammoniakgehaltes. *Polyt. Journ.*, bd. cvii, pp. 379-391. [1860.]
7668. — Untersuchung der Braunkohle von Elbogen in Böhmen, hinsichtlich ihrer Verwendbarkeit zur Photogen- und Paraffin-fabrication. *Ibid.*, bd. cxix, p. 467. [1863.]
7669. — Die technische Verwerthung des Steinkohlentheers, nebst einem Anhang: Ueber die Darstellung des natürlichen Asphalttheers und Asphaltmastix aus den Asphaltsteinen und bituminösen Schiefen und Verwerthung der Nebenproducte. Vienna, 1878.
7670. **Theobald, W.** Notes on the Geology of the Punjab Salt Range. *Journ. As. Soc. Bengal*, ser. 2, vol. xxiii, pp. 651-678. [1854.]
7671. — Note on Petroleum in Burmah, etc. *Rec. Geol. Surv. Ind.*, vol. iii, pt. 3, pp. 72, 73. [1870.]
7672. **Theobald, W.** A brief notice of some recently discovered Petroleum Localities in Pegu. *Rec. Geol. Surv. Ind.*, vol. v, pp. 120-122. [1872.]
7673. — On the Salt Springs of Pegu. *Ibid.*, vol. vi, pp. 67-71, map. [1873.]
7674. — On the Geology of Pegu. *Mem. Geol. Surv. Ind.*, vol. x, pp. 189-359. [1873.]
7675. **Thiel, F.** Die Maikoper Pipe-Line. *Allgem. österr. Chem. Techn.-Zeit.*, bd. xxix, pp. 97, 98. [1911.]
7676. **Thiele, F. C.** Ueber Lima-Ohio Petroleum. *Chem.-Zeit.*, bd. xx, pp. 515, 516. [1896.]
7677. — Texas Petroleum. *Amer. Chem. Journ.*, vol. xxii, pp. 489-493. [1899.]
7678. — Ueber Texas Petroleum. *Chem.-Zeit.*, bd. xxv, p. 433. [1901.]
7679. — Ueber freien Schwefel im Petroleum von Beaumont. *Ibid.*, bd. xxvi, pp. 896, 897. [1902.]
7680. **Thieme, —.** Die Organisation der Bakuer Naphta-Industrie. 1881.
7681. **Thiess, F.** Einige Mittheilungen über die Salzaubeute, Naphthagewinnung und das Vorkommen von nutzbaren Mineralien in Transkaspien. *Zeitschr. Berg-, Hütt.-Salinenw.*, bd. xviii, pp. 133, 134. [1899.]
7682. — Die Erdölvorkommen im europäischen und asiatischen Russland. *Ibid.*, bd. lii, pp. 12-16. [1904.]
7683. — Die Erdölindustrie und die Erdöllagerstätten Russlands. *Journ. Gasbeleucht.*, bd. xviii, pp. 707-709. [1905.]
7684. — Das Berg- und Salinenwesen in Russland mittelasiatischer Besitzungen. *Zeitschr. Berg-, Hütt.-Salinenw.*, bd. liv, pp. 189-197. [1906.]
7685. **Thiessing, J.** The Mineral Resources of Switzerland. *Min. Mag. Rev.*, vol. i, pp. 329-340, 425-429. [1872.]
7686. — Notice sur les richesses minérales de la Suisse. *Emul. Jurass.*, t. i, pp. 53-64. [1876.]
7687. **Thiria, E., and J. J. Ebelmen.** Expériences faites dans le laboratoire de Chimie de Vesoul. *Ann. Mines*, sér. 3, t. xiv, pp. 259-290; t. xviii, pp. 183-197. [1838, 1840.]
7688. **Thörner, W.** Das Petroleum, seine Gewinnung, Verwerthung und Verfälschung. *5th Jahrb. nat. Ver. Osnabruck*, pp. 29-54. [1883.]
7689. — Die Leuchtkraft verschiedener Petroleumsorten des Handels und ihrer Lichteffect und Oelverbrauch der gebräuchlicheren Petroleum-Lampensysteme. *Chem.-Zeit.*, bd. viii, pp. 876, 877. [1884.]
7690. — Experimental-Untersuchung über das Petroleum als Leuchtmaterial. *Ibid.*, bd. x, pp. 528-530, 553, 554, 573, 574, 582, 583, 601-603. [1886.]
7691. **Thomas, Gabriel.** An Historical and Geographical Account of the Province and Country of Pensilvania and of West New Jersey in America. 12mo, London, 1698.
7692. **Thomas, G. L., and S. Young.** The Vapour-Pressures, Specific Volumes and Critical Constants of Normal Hexane. *Journ. Chem. Soc.*, vol. lxvii, pp. 1071-1084. [1895.]
- Thomas, G. L., see Young, S.**
7693. **Thomas, J. S. G., and W. Watson.** The Physical Properties of some Commercial Petrols. *Proc. Inst. Automob. Eng.*, n.s., vol. iii, pp. 429-473. [1909.]
7694. **Thompson, A. B.** The Oil-Fields of Russia. 8vo, London, 1904.
7695. — The Oil-Fields of Peru. *Petrol. Rev.*, vol. xi, pp. 231, 232. [1904.]
7696. — Petroleum Mining and Oil-Field Development. 8vo, London, 1910.
7697. — Maikoper Oil-Field. *Mining Mag.*, vol. ii, pp. 277-280. [1910.]
7698. — Notes on the Irregular Distribution of Petroleum. *Compt. Rend. Congr. internat. Pétrole*, sess. 3, t. ii, pp. 187-198. [1910.]
7699. — The Relationship of Structure and Petrology with Occurrence of Petroleum. *Trans. Inst. Min. Metall.*, vol. xx, pp. 215-269. [1911.]

7700. **Thompson, B.** The Oil Well at Husbands Bosworth. *Journ. Northamp. Nat. Hist. Soc.*, vol. xlii, pp. 267-269. [1906.]
7701. **Thompson, C. O.** Gas from Gasoline. *Amer. Chem.*, vol. vi, pp. 11, 12. [1875.]
7702. **Thompson, M.** Natural Gas. *Ann. Rep. Geol. Indiana*, vol. xv, pp. 314-333. [1886.]
7703. ——— The Wabash Arch. *Ibid.*, pp. 228-241; vol. xvi, pp. 41-53. [1886, 1889.]
7704. **Thompson, W. H.** Partial Report of Survey of the Western Division, including Sketches of Pulaski and White Counties. *Ibid.*, vol. xvi, pp. 131-154. [1889.]
7705. **Thompson, W. P.** Note on Rave's Process for the Utilisation of the Acid Tar Residues of Petroleum Manufacturers. *Journ. Soc. Chem. Ind.*, vol. vii, pp. 303-305. [1888.]
7706. **Thoms, G.** [Petroliferous Rocks of Ferghana (Central Asia).] *Trudi Imp. Voln. Ekonom. Obsch.*, 1887, pp. 82-96.
7707. **Thomsen, J.** Ueber den relativen Wert der zur Bestimmung der Verbrennungswärme flüchtiger organischer Verbindungen benützten kalorimetrischen Methoden. *Zeitschr. physik. Chem.*, bd. ii, pp. 657-672. [1905.]
7708. **Thomson, J. H., and B. Redwood.** Handbook on Petroleum for Inspectors under the Petroleum Acts, and for those engaged in the storage, transport, distribution and industrial use of Petroleum and its Products, and Calcium Carbide; with suggestions on the construction and use of Mineral Oil Lamps. 8vo, London, 1901.
7709. ——— The Petroleum Lamp, its choice and use. A Guide to the safe employment of Mineral Oil in what is commonly termed the Paraffin Lamp. 8vo, London, 1902.
7710. **Thomson, J. S.** The Determination of Impurities in Paraffin Scale, etc. *Journ. Soc. Chem. Ind.*, vol. x, pp. 342-347. [1891.]
7711. **Thomson, T.** On the Gaseous Combinations of Hydrogen and Carbon. *Mem. Wern. Soc.*, vol. i, pp. 504-525. [1810.]
7712. ——— Analysis of Naphtha from Persia. *Ann. Phil.*, vol. xv, pp. 307-309. [1820.]
7713. **Thomson, W.** On the Estimation of Mineral Oil or Paraffin Wax when mixed with other oils or fats. *Rep. Brit. Assoc.*, 1878, Sects., p. 508.
7714. ——— The connection between Flash Point and Danger in burning Mineral Oils. *Journ. Soc. Chem. Ind.*, vol. xviii, pp. 560, 561. [1899.]
7715. ——— Lamp Explosions in Manchester. Report on the Flash-point of Oils. *Manchester Guardian*, April 14, 1899.
7716. **Thore, J.** [Petroleum in the Pyrenees.] *Bull. Soc. Ramond*, ann. xi. [1876.]
7717. **Thorne, J.** The Rosedale Coal Veln. *West. Rev. Sci. Ind.*, vol. ii, pp. 210, 257. [1878.]
7718. ——— The Rosedale Gas and Coal Wells. *Kansas City Rev. Sci. Ind.*, vol. iii, pp. 410-412. [1879.]
7719. **Thorne, L. T.** Note on an Apparatus for Fractional Distillation under reduced Pressures. *Journ. Chem. Soc.*, vol. xliii, pp. 301, 302. [1883.]
7720. ——— Experiments on Oxygenated Oil-Gas (Tatham's Process) as an Illuminant. *Trans. Gas. Inst.*, 1890, pp. 143-147.
7721. **Thornton, E.** A Gazetteer of the Territories under the Government of the East India Company. . . . 4 vols. 8vo, London, 1854.
7722. ——— Oil-springs near Kohat. *Gazetteer of India*, 1862, p. 509.
7723. **Thornycroft, J. E.** Advantages of Gas and Oil Engines for Marine Propulsion. *Trans. Inst. Naval Archit.*, vol. xli, pp. 145-150, 162-167. [1904.]
7724. **Thornycroft, J. I.** Internal Combustion Engines for Marine Purposes. *Cassier's Mag.*, vol. xxxv, pp. 225-240. [1908.]
7725. **Thorp, F. H.** Outlines of Industrial Chemistry. *New York*, 1898.
- Thorp, W.,** see Groves, C. E.
7726. **Thorpe, T. E.** On the Chemical Constitution of Paraffin. *Proc. Phil. Soc. Glasgow*, vol. vii, pp. 454-456. [1871.]
7727. ——— Coal, its History and Uses. 8vo, London, 1878.
7728. ——— Dictionary of Applied Chemistry. 3 vols. 8vo, London, 1890-1893.
7729. **Thorpe, T. E., and L. M. Jones.** The Thermal Expansion and Specific Volumes of Certain Paraffins and Paraffin Derivatives. *Journ. Chem. Soc.*, vol. lxiii, pp. 273-292. [1893.]
7730. **Thorpe, T. E., and A. W. Rücker.** On the Critical Temperature of Heptane. *Ibid.*, vol. xiv, pp. 165, 166. [1884.]
7731. **Thorpe, T. E., and John Young.** Preliminary Notice on the Production of the Olefines from Paraffin by distillation under pressure. *Proc. Roy. Soc.*, vol. xix, pp. 370, 371. [1871.]
7732. ——— On the combined Action of Heat and Pressure upon the Paraffins. *Ibid.*, vol. xx, pp. 488-491; vol. xxi, pp. 184-201. [1872, 1873.]
- Thorpe, T. E.,** see Schorlemmer, C.
- Thos y Codina, S.,** see Maureta, J.
- Thouard, L.,** see Beco, J.
7733. **Thürach, H.** Bericht über die Excursionen am 29 und 30 März und am 1 April [Elsässische Oelfelde]. *Mith. geol. Landesanst. Elsass-Lothr.*, bd. i, pp. 15, 187; bd. ii, pl. vi. [1890, 1892.]
7734. **Thumann, H.** Der Gothan'sche "Stratometer," Apparat zur Ermittlungen des Streichens und Einfallens der Gebirgsschichten in Bohrkörnern und der Abweichung der letzteren von der Lothlinie. *Zeitschr. prakt. Geol.*, bd. ix, pp. 389-391. [1901.]
7735. **Thurston, G. H.** Pittsburgh's Progress, Industries and Resources. 8vo, Pittsburgh, 1886.
7736. **Thurston, R. H.** Friction and Lubrication. Determination of the laws and coefficients of friction by new methods and with new apparatus. 8vo, London, 1879.
7737. ——— Tests of Lubricants. *Proc. New. Engl. Cotton Manuf. Assoc.*, 1880.
7738. ——— Treatise on Friction and Lost Work in Machinery and Millwork. 8vo, New York, 1885.
7739. **Thwaité, B. H.** Liquid Fuel: its Advantages for Firing Steam Generators. 8vo, London, 1887.
7740. ——— Gaseous Fuel. A Lecture delivered at the Association Hall, Peter Street, Manchester, on March 29, 1886. London, 1889.
7741. **Tideman, O. T.** [On the Preparation of Pure Kerosenic Acid and its Salts.] *Trudi Bak. Old. Imp. Russk. Techn. Obsch.*, 1893, pp. 56, 67.
7742. **Tietze, E.** Das Petroleum-Vorkommen von Dragomir in der Marmaros. *Verh. k.-k. geol. Reichs.*, 1878, pp. 322-324.
7743. ——— Die Mineralreichthümer Persiens. *Jahrb. k.-k. geol. Reichs.*, bd. xxix, pp. 565-658. [1879.]
7744. ——— Die Thalgebiete des Opor und der Swica in Galizien. *Verh. k.-k. geol. Reichs.*, 1879, pp. 162-164.
7745. ——— Die Gegend von Rospucie in Galizien. *Ibid.*, 1880, pp. 255-260.
7746. ——— Bemerkungen zu den Ansichten von F. Kreuzt über das Erdöl der galizischen Salzformation. *Ibid.*, 1881, pp. 59-65.
7747. ——— Notizen über die Gegend zwischen Flojescht und Kimpina in der Wallachei. *Jahrb. k.-k. geol. Reichs.*, bd. xxxiii, pp. 381-396. [1883.]
7748. ——— Geologische Uebersicht von Montenegro. *Ibid.*, bd. xxxiv, pp. 1-110, map (1: 450,000). [1884.]
7749. ——— Einige Notizen aus dem nordöstlichen Ungarn. *Verh. k.-k. geol. Reichs.*, 1885, pp. 327-347.
7750. ——— Beiträge zur Geologie von Lykien. *Jahrb. k.-k. geol. Reichs.*, bd. xxxv, pp. 283-336, pl. vi (map). 1885.
7751. ——— Ueber den Bodenplastik und die geologische Beschaffenheit Persiens. *Mith. k.-k. geogr. Ges. Wien*, bd. xxix, pp. 513-523, 561-575. [1886.]

7752. **Tietze, E.** Beiträge zur Geologie von Galizien. F. Krosno; G. Wietrzno; H. Iwonica; I. Nadworna und Kolomea; J. Dollna und Rozniatow; K. Maidan bei Rosolna. *Jahrb. k.-k. geol. Reichs.*, bd. xxxix, pp. 289-370. [1889.]
7753. — Beiträge zur Geologie von Galizien. T. Polana. *Ibid.*, bd. xlii, pp. 67-72. [1891.]
7754. — Beiträge zur Geologie von Galizien. X. H. Walter; Y. Foraminiferen für Altersbestimmung. *Ibid.*, bd. xlii, pp. 385-410. [1896.]
7755. **Tietze, E.**, see **Paul, C. M.**
7756. **Tigerstedt, A.** Eine Vereinfachung bei der fractionirten Destillation. *Ber. deutsch. chem. Ges.*, bd. xxvi, pp. 72. [1893.]
7757. **Tikhonovitch, N.** [Preliminary Report on the Expedition of 1908 to the Schmidt Peninsula, North Sakhalin.] *Bull. Com. géol. Russ.*, t. xxviii, pp. 13-62, pl. iii. [1909.]
7757. **Tikhonovitch, N.**, and **P. Polevov.** [Economic Minerals of Sakhalin.] *Ibid.*, t. xxix, pp. 715-754, pl. xvii. [1910.]
7758. **Tikhvinski, M. M.** [New Dephlegmator for Fractional Distillation of Substances of High Boiling-point.] *Journ. Russ. Phiz. Khim. Obsch.*, t. xli, otd. 1, pp. 81-89. [1909.]
7759. **Tikhvinski, M.** [Occurrence in Russian Petroleum of Hexahydrocymene and p-Menthane.] *Ibid.*, t. xli, otd. 1, p. 1136. [1909.]
7760. **Tilden, W. A.** On the Gases enclosed in Crystalline Rocks and Minerals. *Proc. Roy. Soc.*, vol. ix, pp. 453-457. [1897.]
7761. **Tilson, G. W.** Asphalt and Asphalt Pavements. *Trans. Amer. Soc. Civ. Eng.*, vol. xxxviii, pp. 215-245. [1897.]
7762. **Time, I.** [Oil Pipe-Line from Baku to Batum.] *Zap. Imp. Russk. Tekhn. Obsch.*, g. xix, Trudi otd. 1, v. x, pp. 9. [1885.]
7763. **Timpson, F. M.** Oil Engines for Marine Purposes. *Trans. Inst. Marine Eng.*, vol. xviii, no. 134. P. 42, pl. [1907.]
7764. **Tingry, —.** Recherches analytiques sur les schistes de Salenche. *Mem. Acad. Torino*, t. ii, pp. 1-106. [1784.]
7765. **Tischtenko, W. E.** [On the Distillation Products of Petroleum Tar.] *Journ. Russk. Phiz. Khim. Obsch.*, t. xxv, pp. 48-51. [1893.]
7766. **Tisengoldt, V. R.**, and **I. F. Schreder.** [Lamps for Kerosene and Heavy Oils.] *Zap. Imp. Russk. Tekhn. Obsch.*, g. xxiii, Aug.-Sept., pp. 52, 3 pls. [1889.]
7767. **Titus, R.** Rilmänien's Petroleumindustrie und die Bohrtechnik. *Allgem. österr. Chem. Techn. Zeit.*, bd. xxix, pp. 137-139. [1911.]
7768. — Der automatische Separator zur Trennung von Rohöl und Wasser. *Ibid.*, p. 153. [1911.]
7769. — Ueber Gesteinbruch beim Spülbohren. *Org. Ver. Bohrtechn.*, bd. xviii, pp. 133-135, 147, 148. [1911.]
7770. — Ueber Explosionen und Verwendung der Gasmotorer im Grubendienste bei Bohrungen auf Rohöl. *Ibid.*, pp. 182, 183. [1911.]
7771. — Beitrag zur Wasserabsperrung in Bohrlöchern. *Ibid.*, pp. 206, 207. [1911.]
7772. **Tobey, H. W.** Dielectric Strength of Oil. *Electrician*, vol. lxvi, pp. 491-493. [1911.]
7773. **Tobin, J.** Account of the Pitch-Lake in the Island of Trinidad. *Trans. Linn. Soc.*, vol. viii, pp. 253-255. [1807.]
7774. **Tobler, A.** Topographische und geologische Beschreibung der Petroleumgebiete bei Moeara Enim. *Tijdschr. R. Ned. Aardr. Gen.*, 1906, pp. iv, 199-315, 5 pls.
7775. **Tocher, J. F.** The Production of Gas from Paraffin Oils, and from pure members of Paraffin and Terpene Series. *Journ. Soc. Chem. Ind.*, vol. xiii, pp. 231-237. [1894.]
7776. **Todd, J. E.** Mineral Building-Material, Fuels and Waters of South Dakota. *Bull. Geol. Surv. S. Dakota*, no. 3, pp. 81-130, pls. xxi-xxxi. [1902.]
7777. **Todd, J. E.** Aberdeen-Redfield, S. Dakota. *Fo 165, U.S. Geol. Surv.*, 1909.
7778. **Todoros, —.** see **Orgels, L.**
7778. **Törnebohm, A. E.** On Nullabergets bituminösa bergart. *Geol. Fören. Stockh. Förh.*, bd. ix, pp. 381-396. [1887.]
7779. — Kloritoid und bergbeck I ett quartzbrott på Kolmården. *Ibid.*, bd. xiv, pp. 137-147. [1892.]
7780. **Törnquist, S. L.** Geologiska iakttagelser ofver den kambriska och siluriska lagföljden i Siljanstrakten. *Oefv. k. Vet.-Akad. Förh.*, 1871, pp. 83-129, pls. 1, ii.
7781. **Tolmidsi, D.** Les Superficies des Terrains consolidés pour l'Exploitation du Pétrole en Roumanie en 1905-1907. *Compt. Rend. Congr. internat. Pétrole*, sess. 3, t. ii, pp. 879, 880. [1910.]
7782. **Tomlinson, C.** The Economic History of Paraffine. *Journ. Soc. Arts*, vol. ix, pp. 295-303. [1861.]
7783. **Tompkins, P. W.** Notes and Methods on the Determination of Water, Sand, etc., in Crude Petroleum of Low Gravity. [Pacific Coast Gas Assoc.] *Amer. Gas Light Journ.*, vol. lxxvii, pp. 435-437. 1902.
7783. **Tompkins, P. W.**, see **Curtis, M.**
7784. **Tondi, M.** Relazione sul carbon fossile di Gifoni. *Atti Acc. Sci. Fis. Napoli*, vol. ii, pp. 25-32. [1825.]
7785. **Tooke, W.** View of the Russian Empire during the Reign of Catherine the Second, and to the close of the Present Century. 3 vols. 8vo, London, 1799.
7786. **Tooke, W. A.** Oil Engines: their Selection, Erection, and Correction. 8vo, London, 1904.
7787. — Oil Engines. *Trans. Manchester Assoc. Eng.* 1908, pp. 21-78.
7788. **Toone, C.** Asphalts and Bitumens in Electrical Work. *Cassier's Mag.*, vol. xxxix, pp. 216-219. [1911.]
7789. **Topley, W.** The Sources of Petroleum and Natural Gas. *Journ. Soc. Arts*, vol. xxxix, pp. 421-437. [1891.]
7790. — The Geology of Petroleum and Natural Gas. *Rep. Brit. Assoc.*, 1891, pp. 637, 638. [1892.]
7791. **Toroceanu, V.** Les Gisements Petrolifères de la Roumanie. *Journ. Petr.*, t. vi, pp. 341-346. [1906.]
7792. — [The Petroleum Industry of Rumania.] *Monit. Int. Pétrol. Roum.*, t. ix, 1908.
7792. **Toroceanu, V.**, see **Mrazec, L.**
7793. **Torosiewicz, T. v.** Physikalisch-chemische Untersuchung der Mineralquellen zu Truskawice bei Drobobycz im Königreiche Galizien. *Rep. Pharm.*, bd. iv, pp. 1-50, 145-164. [1836.]
7794. — Beitrag zur Kenntniss der Mineralquellen zu Truskawice. *Ibid.*, bd. lxi, pp. 395-400. [1837.]
7795. **Torres Garcia, D.** Informe relativo a los depósitos de asfalto pitholium en el Estado de Jalisco [Mexico]. *Min. Mex.*, t. xi, no. 17. [1884.]
7796. **Toschi, A.** Sur les terrains qui environnent le petit volcan (terreno ardente) de Pietramala, en Toscane. *Bull. Soc. Géol. France*, sér. 2, t. vi, pp. 473, 474. [1849.]
7797. **Toth, J.** Zur Frage über die technische Asphaltanalyse. *Chem.-Zeit.*, bd. xxix, pp. 899, 900. [1905.]
7798. **Toth, M.** [Hungarian Minerals.] *Kolozsvár*, 1882.
7799. **Tournaire, —.** Industrie des Hules de Schiste dans l'Autunois. *Ann. Mines*, sér. 6, t. xx, pp. 429-474, pls. vii-ix. [1871.]
7800. **Tournal, —.** Découverte d'une fontaine ardente dans l'arrondissement de Narbonne. *Compt. Rend.*, t. lxxv, pp. 115, 116. [1867.]
7801. **Tournier, E. A.** Les Pétoles de Bakou. *La Nature*, t. xxii, pp. 38-40. [1883.]
7802. **Tower, —.** The Story of Oil. *New York*, 1909.
7803. **Tower, B.** First Report on Friction Experiments. *Engineering*, vol. xxxvi, pp. 451, 452. [1883.]
7804. **Tower, W. S.** Petroleum and Minor Mineral Products in Pennsylvania. *Bull. Philadel. Geogr. Soc.*, vol. v, pp. 24-41. [1907.]
7805. **Towl, F. M.** Test of an 85 H.P. Oil Engine. *Journ. Amer. Soc. Mech. Eng.*, vol. xxxiii, pp. 1351-1360. [1911.]

7806. **Towle, H. L.** The Ultimate Limit of Speed of Internal Combustion Engines. *Amer. Machinist*, vol. xxviii, pt. 1, pp. 317-319. [1905.]
7807. **Towler, J.** Pitch Lake of Trinidad. *Rep. Cons. U.S.*, vol. ix, pp. 139-141. [1883.]
7808. ——— Asphalt of Trinidad. *Ibid.*, vol. xi, pp. 600, 601. [1884.]
- Townsend, E. J.**, see **Noad, J.**
7809. **Townsend, R. A.** Report on the Petroleum Exploration at Khatan. *Rec. Geol. Surv. Ind.*, vol. xix, pp. 204-210, pl. [1886.]
7810. ——— Report on the Assam Petroleum Deposits. *Simla*, 1888.
7811. **Tozzetti, G. T.** Relazioni d'alcuni Viaggi fatti in diverse Parti della Toscana per osservare le produzioni naturali e gli antichi monumenti di essa. 12 Tt. 8vo, Florence, 1768.
7812. ——— Dei monti ignivomi della Toscana e del Vesuvio. *Leghorn*, 1799.
7813. **Trabucco, G.** Bacini petroliferi della provincia di Piacenza. 16mo, Piacenza, 1890.
7814. **Trail, T. S.** Description of the Coal [Asphalt] recently discovered on the Estates of the Count de Regla [Real del Monte] in Mexico. *Quart. Journ. Sci. Lit. Arts*, vol. xix, pp. 26-28. [1825.]
7815. ——— On the Torbanell Mineral. *Trans. Roy. Soc. Edinb.*, vol. xxi, pp. 7-14. [1854.]
7816. **Traub, P.** Les Solfatares de la Mer Rouge. *Bull. Soc. Sci. Nat. Neuchâtel*, t. viii, pp. 417-421. [1870.]
7817. **Trautschold, H.** Ueber die Naphtaquellen von Baku. *Zeitschr. deutsch. geol. Gesell.*, bd. xxvi, pp. 257-274, pl. iv. [1874.]
7818. ——— [Ural Mountains.] *Ibid.*, bd. xxvii, pp. 703-706. [1875.]
7819. **Travaglia, R.** Distretto di Caltanissetta. *Riv. Serv. Min.*, 1892, pp. 37-75. [1894.]
7820. **Treloar, T.** Notice of an Issue of Inflammable Gas in the Morro Verde Gold Mine, Brazil. *Trans. R. Geol. Soc. Cornwall*, vol. vii, pp. 345, 346. [1858.]
7821. **Tremlett, —.** Report for the year 1900 on the Trade, Commerce, and Navigation of French Indo-China. *Dipl. Cons. Rep.*, ann. ser., no. 2618. [1901.]
7822. **Treschel, F.** Le Champ de Pétrole de Campina. *Monit. Int. Pérol. Roum.*, t. iv, 1903.
7823. **Treumann, —.** [Burners for highly-carbonised Oils.] *Protok. St. Petersb. Polyt. Ver.*, 1884.
7824. **Treumann, J.** Mineral-Schmierzle. *Ann. Geverb. Bauwesen*, bd. xxi, pp. 176-180, 192-194. [1887.]
7825. ——— Erwiderung auf die Bemerkungen der Herrn Schädler zu einem Vortrage des Herrn Treumann [zur Mineralschmierzle]. *Polyt. Journ.*, bd. cclxviii, pp. 474-478. [1888.]
7826. **Trevithick, J. H.** A Sketchy Report on the Petroleum Industry at Baku. *Geol. Surv., Egypt*, 1896.
- Tribe, A.**, see **Gladstone, J. H.**
7827. **Tribolet, M. de.** Note sur les gisements d'Asphalte d'Hanover, comparés à ceux du Val de Travers. *Bull. Soc. Sci. Nat. Neuchâtel*, t. xi, pp. 266-271. [1878.]
7828. ——— Notes Géologiques et Paléontologiques sur le Jura neuchâtelois. IX. Sur la présence de fossiles du Gault aux mines d'asphalte (Presta) du Val-de-Travers. *Ibid.*, pp. 531-533. [1879.]
7829. **Trinker, J.** Petroleum-quellen in den Abruzzen. *Verh. k.-k. geol. Reichs.*, 1866, pp. 3, 4.
7830. ——— Musterstücke von Bitumen aus Istrien und Dalmatien. *Ibid.*, 1868, pp. 355, 356.
7831. **Tripler, A. B.** Mode de Traitement de l'Asphalt de Cuba. *Technol.*, t. xx, pp. 583, 584. [1859.]
7832. **Tristram, H. B.** On the Sulphur and Bitumen Deposit at the South-west Corner of the Dead Sea. *Rep. Brit. Assoc.*, 1864, Sect., p. 73. [1865.]
7833. **Trommsdorff, J. B.** Ueber eine natürliche vorkommende feste Verbindung von Kohlenwasserstoff. *Ann. Chem. Pharm.*, bd. xxi, pp. 126-130. [1837.]
7834. **Tronquoy, C.** Nouveaux réservoirs pour l'emmagasinement des huiles de pétrole et autres matières inflammables plus légères que l'eau. *Ann. Gén. Civ.*, t. v, pp. 640, 641, [1866.]
7835. **Troost, —.** Extrait d'un rapport fait au Conseil de salubrité de la Seine sur un moyen de diminuer les dangers du pétrole proposé par M. Jordery. *Journ. Pharm. Chim.*, sér. 4, t. xvii, pp. 348, 349.
7836. **Trop, S.** [The Exclusion of Water from Petroleum Wells.] *Trudi Bak. Old. Imp. Russ. Techn. Obsch.*, 1900.
7837. **Trotter, H.** Reports for 1890-1892 on the Trade of Beyrout. *Dipl. Cons. Rep.*, ann. ser., nos. 908, 1279. [1891, 1893.]
7838. ——— Report for 1895, 1896 on the Trade of Galatz. *Ibid.*, nos. 1775, 1918. [1896, 1897.]
7839. ——— Report on the Trade of Roumania for the Year 1905. *Ibid.*, no. 3618. [1906.]
7840. **Truchot, P.** L'Eclairage à Incandescence par le Gaz et les liquides gazéifiés. 8vo, Paris, 1899.
7841. **Trusson, — v.** Nachrichten über die Naphta-Quellen und das sogenannte Feuerlande bei Baku. *Schr. Russk. k. Ges. Min.*, bd. i, pp. 232-245. [1842.]
7842. **Tsulukidze, K.** [Geology of Apsheron Peninsula and the Navtluga District, S.E. of Tiflis.] *Mat. geol. Kavk.* 1881.
7843. **Tsulukidze, K.** — **Archipov**, and — **Krafft**. [Geological Examination of the Baku District in 1870.] 1872.
- Türgensen, R.**, see **Böhm, M.**
7844. **Türschmidt, A.** Die Benutzung abzulehrender Ziegelfenigense zum Kohlen- und Teerschwelen. *Verh. polyt. Ges. Berlin*, bd. xxii, pp. 49-68. [1861.]
7845. **Tully, C. B.** The Methane-Hydrogen Generator Adapted to a Carburetted Water Gas Plant for the Production of Carburetted Methane-Hydrogen Gas. *Proc. Irish Assoc. Gas Managers*, 18th meeting, pp. 15-23. [1905.]
7846. **Tultschinski, —.** Economic Minerals of Russian Sakhalin. *St. Petersburg*, 1906.
7847. **Tumski, K. I.** [Oil and its Products.] *Moscow*, 1879.
7848. ——— [Kerosene House-Illumination.] *Moscow*, 1880.
7849. ——— [Technology of Naphtha.] 4to, *Moscow*, 1891.
7850. ——— [The Petroleum Industry of the Terek Province.] *Trudi Bak. Old. Imp. Russk. Techn. Obsch.*, kn. xi, p. 80. [1896.]
7851. ——— [Our Petroleum Industry.] *Russk. Misl.*, March 1897.
7852. ——— [Petroleum of Uchta.] *Tekhn. Viestn.* 1907, tch. 1, p. 223.
7853. **Turgan, L.** Les Voitures Automotrices de Chemins de Fer, à Vapeur et à Pétrole. *Mém. Soc. Ing. Civ.*, 1904, vol. i, pp. 486-519, pl. 58.
- Turner, H. W.**, see **Lindgren, W.**
7854. **Turner, N. L.** The Petroleum Industry of Canada. *Journ. Hamilton Sci. Assoc.*, vol. xxiv, pp. 16. [1908.]
7855. **Turner S.** Account of an Embassy to the Court of the Teshoo Lama in Thibet, containing a Narrative of a Journey through Bootan and part of Thibet. . . . *London*, 1800.
7856. **Tutschew, J.** Kurze Notiz über eine sogenannte Beuteuchungsnaphta. *Bull. Ac. Imp. Sci. St. Petersb.*, t. vii, pp. 515-518. [1864.]
7857. **Tweddle, H. jun.** The Petroleum Industries of Europe. *Engineering*, vol. xii, pp. 99, 100, 149-152, 193, 194, 239, 240, 242, 243, 289, 290, 341, 342, maps and sections. [1886.]
7858. ——— Crude Petroleum and its Products as Fuel. *Eng. Min. Journ.*, vol. lxxvii, pp. 459, 460, 488-490, 517-520. [1899.]
7859. **Tweddle, H. W. C.** Petrocene and its Products. *Journ. Franklin Inst.*, vol. cli, pp. 204-207. [1876.]
7860. **Twelvetrees, W. H.** Report on Kerosene-Shale and Coal Seams in the Parish of Preolenna. *Rep. Dep. Mines Tasmania*, 1903.
7861. **Twite, R. C. N.** Oil Industry of Roumania. *Mining Mag.*, vol. v, pp. 453-457. [1911.]
7862. **Tylee, —.** On Barbadoes Naphtha. *Pharm. Journ.*, vol. iv, pp. 73-75. [1845.]

7863. **Tyrrill, J. B.** Report on the Country between Athabasca Lake and Churchill River. *Ann. Rep. Geol. Surv. Canada*, n.s., vol. viii, report D, pp. 119. [1900.]
7864. **Ubbelohde, L.** Abhängigkeit der Siedepunkte der Erdöldestillate vom Barometerstande. *Zeitschr. angew. Chem.*, bd. xix, pp. 1855, 1856. [1906.]
7865. ——— Ehrenrettung des Kranzbrenners des Englischen Schmierölviskosimeters. *Chem.-Zeit.*, bd. xxxi, p. 28. [1907.]
7866. ——— Einige Neuerungen am Englischen Schmierölviskosimeter, und Tabellen für das Viskosimeter. *Ibid.*, pp. 38, 39. [1907.]
7867. ——— Bestimmung der Siedegrenzen von Petroleum. *Mith. k. Mat.-prüf.-Amt.*, bd. xxv, pp. 261-267. [1907.]
7868. ——— Handbuch der Chemie und Technologie der Oele und Fette, Chemie, Analyse, Gewinnung und Verarbeitung der Oele, Fette, Wachse und Harze. 4 Bde, Leipzig, 1908-1911.
7869. ——— Die Zähigkeit des Leuchtpetroleums und ein Apparat zu ihrer Bestimmung. *Petroleum Zeitschr.*, bd. iv, pp. 861-864. [1909.]
7870. ——— Bemerkungen zu einigen Arbeiten Rakusins über das geologische Alter und über die optische Aktivität des Erdöls. *Ibid.*, pp. 1394-1397. [1909.]
7871. ——— Ueber einige merkwürdige Oel- und Gasquellen in den Vereinigten Staaten von Nordamerika. *Seifensied.-Zeit.*, bd. xxxvi, p. 209-211. [1909.]
7872. ——— Bemerkungen zu den Abhandlungen von M. Rakusin: "Ueber das optische Drehungsvermögen der natürlichen Erdöle im polarimetrisch leeren Zustande," und "Ueber den Paraffingehalt der Erdöle als Kriterium zur Beurteilung des relativen geologischen Alters der selben." *Ber. deutsch. chem. Ges.*, bd. xlii, pp. 3242-3247. [1909.]
7873. ——— Antwort auf die Mitteilung von M. Rakusin: Ueber die Notwendigkeit systematischer, optisch-chemischer Erdölstudien. *Ibid.*, bd. xliii, pp. 608, 609. [1910.]
7874. ——— Die Kurssteigerung der Petroleum-Aktien und ihre Ursachen. *Allgem. österr. Chem.-Techn.-Zeit.*, bd. xxviii, pp. 49, 50. [1910.]
7875. ——— Zur Regierungsvorlage, betreffend die Herstellung von Erdölreservoiren und sonstige Massnahmen zur Regelung der Mineralöl-Industrie in Oesterreich. *Petroleum Zeitschr.*, bd. v, pp. 746-757. [1910.]
7876. ——— Ein Petroleummonopol in Oesterreich? *Ibid.*, pp. 757-759, 794-797. [1910.]
7877. ——— Rôle de la Vapeur Surchauffée dans la Distillation des Parties du Pétrole Bouillant Rapide. *Journ. Pét.*, t. x, pp. 88, 89. [1910.]
7878. **Ubbelohde, L.** and **S. Woronin.** Ueber die Einwirkung von Katalysatoren auf Erdöl. *Petroleum Zeitschr.*, bd. vii, pp. 9-13: 334-339. [1911, 1912.]
- Ubbelohde, L.**, see **Holde, D.**
7879. **Udden, J. A.** Geology of Muscatine County. *Ann. Rep. Iowa Geol. Surv.*, vol. ix, pp. 247-380, pls. v-vii, and 2 maps, 1: 125,000. [1899.]
7880. ——— Geology of Louisa Co. *Ibid.*, vol. xi, pp. 55-126, pl. iv, 2 geol. maps, 1: 126,720. [1901.]
7881. **Udden, Jo.** Coal Deposits and Possible Oil Field near Duquoin, Illinois. *Bull. Geol. Surv. Illinois*, no. 14, pp. 254-262. [1910.]
7882. **Udtski, G.** [Description of an Apparatus for preserving Kerosene and other volatile, combustible Liquids.] *Zap. Imp. Russk. Tekhn. Obsch.*, g. xv, otd. 1, pp. 27, 28. [1881.]
7883. **Uelsmann, H.** Ueber einige Derivate des Steinöls. *Ann. Chem. Pharm.*, bd. cxiv, pp. 279-291. [1860.]
7884. **Uhlenbuth, E.** Handbuch der Photogen- und Paraffin-Fabrikation aus Torf, Braunkohle und bituminösem Schiefer. *Svo, Quedlinburg*, 1858.
7885. **Uhlig, E. C.** Oil Gas Analysis Apparatus. *Journ. Soc. Chem. Ind.*, vol. xxix, pp. 196, 197. [1911.]
7886. **Uhlig, V.** Beiträge zur Geologie der westgalizischen Karpathen. *Jahrb. k.-k. geol. Reichs.*, bd. xxxiii, pp. 443-560, pl. iv. [1883.]
7887. **Uhlig, V.** Ueber Vorkommen und Entstehung des Erdöls. *Svo, Berlin*, 1884.
7888. ——— Vorlage der Kartenblätter Pilzno und Clezkwice, Z. 6; Grybow und Gorlice, Z. 7; Bartfeld und Muszyna, Z. 8, der Col. xxiv, und Abwehr gegen die Herren Walter und Dumikowski. *Verh. k.-k. geol. Reichs.*, 1884, pp. 37-48.
7889. ——— [Petroleum.] *Schr. Ver. Verbr. Nat. Kenntn. Wien*, bd. xxvi. [1886.]
7890. ——— Ergebnisse geologische Aufnahmen in den westgalizischen Karpathen. *Jahrb. k.-k. geol. Reichs.*, bd. xxxviii, pp. 83-264, pl. ii. [1888.]
7891. **Uloth, —.** Ueber Petroleum und seine Prüfung nach den reichsgesetzlichen Bestimmungen. *Gewerbbl. Grossherz. Hessen*, bd. xlvii, pp. 65-69. [1884.]
7892. **Ulski, —.** [Investigation of the Bed of the Caspian Sea.] *Morsk. Sbornik*, kn. lxvi, p. 243.
7893. **Ulyanov, N.** [On the Permission of Tugs using Oil Residue Fuel in Fishing Ports.] *Ribinsk*, 1879, 36 pp.
7894. **Ulzer, F.** Verwerthung der Abfallprodukte in der Mineralölindustrie. *Zeitschr. angew. Chem.*, bd. xiii, p. 1273. [1900.]
7895. ——— Jahresbericht der angewandten Chemie und verwandter Gebiete. Die Erdöl-Industrie in 1902. *Chem.-Zeit.*, bd. xxvii, pp. 722-727. [1903.]
7896. **Ulzer, F.**, and **P. Pastrovich.** Jahresbericht über die Fortschritte auf dem Gebiete der Fette und Naphtha-produkte in den Jahren 1905 und 1906. *Ibid.*, bd. xxxi, pp. 747, 748, 770, 771, 779-781. [1907.]
7897. **Ulzer, F.**, and **F. Sommer.** Ueber den Nachweis und die Bestimmung des Paraffins in Mischungen mit Ceresin. *Ibid.*, bd. xxx, pp. 142, 143. [1906.]
7898. **Umanski, M.** [Petroleum Oil. Examination of Mineral Machine Oils for their stability on cooling.] *Zap. Imp. Russk. Tekhn. Obsch.*, g. xxv, Oct., pp. 99-102. [1891.]
- Unanov, M. A.**, see **Khokhlow, M. T.**; and **Zimmerman, A. P.**
7899. **Unger, L.** Ueber die trockne Destillation der Braunkohlen und anderer bituminösen Fossilien, in Retorten, Schacht- und Schmelofen, und Beschreibung eines für den Preussischen Staat und das Königreich Sachsen patentirten Theerschmelofens. *Polyt. Journ.*, bd. cl, pp. 130-141. [1858.]
7900. ——— Ueber die Beschaffenheit und das Vorkommen der zur Theergewinnung sich vorzüglich eignenden Braunkohlen und die Verarbeitung des Theers auf Paraffin, Photogen und Solaröl. *Ibid.*, bd. clv, pp. 41-56. [1860.]
7901. ——— Ueber die qualitative und quantitative Verschiedenheit der Theerausbeute der Braunkohlen, bezüglich der äusseren Beschaffenheit und Lagerungsverhältnisse derselben. *Ibid.*, bd. clviii, pp. 222-231. [1860.]
7902. **Unverdorben, O.** Einiges über das Steinöl. *N. Journ. Chem. Phys.*, bd. lvii, pp. 243-245. [1829.]
- Urban, V.**, see **Salleron, J.**
7903. **Urban, H.** Auf dem Weg zum staatslichen Petroleummonopol in Oesterreich-Ungarn. *Allg. österr. Chem.-Techn.-Zeit.*, bd. xxviii, pp. 57, 58. [1910.]
7904. **Ure, A.** A Dictionary of Arts, Manufactures and Mines. *Svo, London*, 1837.
7905. ——— Experiments to determine the fluency or viscosity of different liquids at the same temperature, and of the same liquids at different temperatures. *Rep. Brit. Assoc.*, 1839, Sect., pp. 22-24.
7906. ——— Report on the Asphaltic Rocks of Val de Travers, Snyssel, Pyrimont, etc., and their Application as Mastic in Footpavements, Roofs, Aqueducts, Cisterns, etc. *London Journ. Arts*, ser. 3, vol. xiv, pp. 251-258. [1833.]
7907. ——— On Naphtha and its [Medicinal] Uses. *Pharm. Journ.*, vol. viii, pp. 65, 66, 125. [1849.]
7908. **Uren, S.** — **Hinkins**, and **J. G. Camp.** Best Form of Oil Furnace for Locomotive Shape Work and Burners for Same. *Rep. Railr. Blacksm. Assoc.*, Conv. xii, pp. 101-108. [1904.]
7909. **Urgantzev, B.** [Export of Russian Kerosene.] *Imp. Russ. Sudokhodstv. Obsch.* 1906.



7910. **Urquhart**, — Oil Trade of Baku for 1902 and 1905. *Dipl. Cons. Rep.*, ann. rep. no. 2979, pp. 22-24; no. 3566, pp. 12-16. [1903, 1906.]
7911. **Urquhart, T.** Apparatus for burning crude Petroleum in Locomotives. *Engineering*, vol. xxiii, p. 9. [1877.]
7912. — On the Use of Petroleum Refuse as Fuel in Locomotive Engines. *Proc. Inst. Mech. Eng.*, 1884, pp. 272-330; 1889, pp. 36-84.
7913. — [Petroleum Firing versus Anthracite on Gryazi-Tsaritsin Railway.] 1885.
7914. — Ueber die Benutzung der Petroleum-Rückstände als Brennmaterial für Locomotive-Feuerung. *Organ Eisenbahnw.*, n.f., bd. xxii, pp. 78, 79, 113-118; bd. xxiii, pp. 176, 177. [1885, 1886.]
7915. — On the Compounding of Locomotives burning Petroleum Refuse in Russia. *Proc. Inst. Mech. Eng.*, 1890, pp. 47-111, pls. 1-31.
7916. **Ursinus, O.** Ueber den gegenwärtigen Stand des Tiefbohrwesens, Allgemeines, Neuerungen, Industrielle Bedeutung (Kali-, Kohlen-, Petroleum-Industrie, etc.). *Bayer. Ind. Gewerb.*, bd. xxxviii, pp. 266-271. [1906.]
7917. — Kalender für Tiefbohr-Ingenieure, Techniker Unternehmer und Bohrmeister. Handbuch für Petroleumfachleute, Berg- und Bau-Ingenieure, Geologen, Balneologen, etc. *Frankfurt a. M.*, 1908.
7918. **Usov, P.** [Asphalt and the Asphalt Industry.] 8vo, *St Petersburg*, 1886.
7919. **Uspenski, N.** [Deposits of Oil, Kir, and Ozokerite at "Naphtha Hill," Transcaspia.] *Gorn. Journ.*, 1895, t. 2, pp. 205-211, pl. x.
7920. **Ussher, J.** A Journey from London to Persepolis, including Wanderings in Daghestan, Georgia, Armenia, Kurdistan, Mesopotamia and Persia. 8vo, *London*, 1865.
7921. **Ussing, N. V.** [Natural Gas in Denmark.] *Ingeniøren*, bd. xiii, p. 49. [1905.]
7922. **Utz**, — Kleine Mitteilungen aus der Laboratoriumspraxis. *Oesterr. Chem.-Zeit.*, bd. vii, pp. 509, 510. [1904.]
7923. — Der Nachweis von Petroleumdestillaten in Terpentintöl. *Apothek.-Zeit.*, bd. xxi, pp. 399, 400. [1906.]
7924. — Beiträge zur Petroleum-Untersuchung. *Chem. Rev. Fett-Harz-Ind.*, bd. xii, pp. 293-296. [1906.]
7925. — Zur Bestimmung der Jodzähl von Petroleum. *Petroleum Zeitschr.*, bd. i, pp. 475, 476. [1906.]
7926. — Ueber die Bromzahl des Petroleum. *Ibid.*, bd. ii, pp. 43-45. [1906.]
- Valberg, Kh. N.**, see **Deschivov, M.**
7927. **Valenta, E.** Beitrag zur Prüfung der Mineralöle. *Polyt. Journ.*, bd. ccliii, pp. 418-421. [1884.]
7928. — Apparat zur fractionirten Destillation unter verminderten Druck. *Zeitschr. anal. Chem.*, bd. xxviii, pp. 673-676. [1889.]
7929. — Ueber eine neue Methode zur Erhöhung der Lichtechtheit des Asphalt (Zinkographie). *Ibid.*, bd. cclxxxiii, pp. 66, 67. [1892.]
7930. — Ueber die Verwendung von Dimethylsulfat zum Nachweis und zur Bestimmungen von Theorien in Gemischen mit Harzölen und Mineralölen, und dessen Verhalten gegen fetten Oele, Terpentintöl und Pinolin. *Chem.-Zeit.*, bd. xxx, pp. 266, 267. [1906.]
7931. **Valentin, E.** Bootsmotoren. *Gasmotorentechnik*, bd. ix, pp. 152-158, 186-188. [1910.]
7932. **Valentina, G. A.** Carbonaceous Mineral or Oil Shale from Brazil. *Proc. S. Wales Inst. Eng.*, vol. xvii, pp. 20-28. [1890.]
7933. **Vallisneri, A.** Raccolta di Varie Osservazioni, Spettanti all' Istoria Medica, e Naturale. 4to, *Venice*, 1711.
7934. **Van den Broeck, E.** Les Mistpoeffers, ou Détonations de la Mer du Nord et des Régions terrestres et maritimes circonvoisines, et les Barisal Guns, du Delta du Gange. *Bull. Soc. belge Géol.*, t. ix, pp. 182-199. [1897.]
7935. — Les Mistpoeffers. *Spelunca*, t. iii, pp. 115-121. [1897.]
7936. **Van der Ropp, A.** The Use of Crude Oil in Smelting. *Eng. Min. Journ.*, vol. lxxv, pp. 81, 82. [1903.]
7937. **Vanderweyde, P. H.** [Improved Fire Test of Illuminating Petroleum, without the Use of Fire.] *Amer. Gaslight Journ.*, vol. xv, pp. 119, 120, 133. [1871.]
- Vanderwoort, H.**, see **Lecoq, E.**
7938. **Vangel, B. v.** Petroleum in the Uchta District. *Petrol. Rev.*, vol. v, pp. 412, 413, 452, 453, 472-475. [1901.]
7939. **Van Horn, F. B.** The Mineral Production of Illinois in 1905-1907. *Illinois Geol. Surv. Circ.*, 1, 2, 4. [1906-1908.]
7940. **Van Ingen, D. A.** Petroleum (in New York). *Bull. N. Y. State Museum*, vol. iii, pp. 558-560. [1896.]
7941. **Van Mellern**, — Petroleum Oil Districts. *New York*, 1865.
7942. **Van Riper, E. G.** Russian and American Petroleum. *Rep. Cons. U.S.*, vol. xii, pp. 271, 272. [1884.]
7943. **Vansittart, A. G.** Report for 1896 on the Trade of Chicago. *Dipl. Cons. Rep.*, ann. ser., no. 1853. [1897.]
7944. **Vanston, W. J. K.** The Petroleum Industry in Canada. *Journ. Soc. Chem. Ind.*, vol. xxii, pp. 393-398. [1903.]
7945. **Vanuxem, L.** First Annual Report of the Geological Survey of the Fourth District of New York. *Ann. Rep. Geol. Surv. N. York*, vol. i, pp. 187-212. [1857.]
7946. — Geology of New York. 4to, *New York*, 1843.
7947. **Vaquinhos, J. d. S.** Timor. *Bol. Soc. Geogr. Lib.*, ser. 3, no. 4, p. 242. [1882.]
7948. **Varenne, E.** Sur la Préparation du Mésitylène. *Bull. Soc. Chim. Paris*, sér. 2, t. xi, pp. 226, 267. [1883.]
- Varenne, E.**, see **Prunier, L.**
7949. **Vasilev, A. K.** [Oil-raising in the Apscheron Peninsula, and present state of boring operations there.] *Gorn. Journ.*, 1885, t. 3, pp. 336-427.
7950. — [Petroleum-Firing for Boilers.] *Ibid.*, 1887, t. 1, pp. 339-378.
7951. — [Boring for Petroleum.] *Zap. Imp. Russk. Tekhn. Obsch.*, g. xxii, v. 2, pp. 35-47. [1888.]
7952. — [State of the Russian Petroleum Industry.] *Ibid.*, g. xxiii, Mar., pp. 39-57. [1889.]
7953. — [Condition of the Petroleum Industry Abroad.] *Ibid.*, Apr., pp. 9-21. [1889.]
7954. — [Oil Production.] *Ibid.*, May, pp. 9-28; Jun., pp. 29-43, 6 pls. [1889.]
7955. — [Ozokerite, its Occurrence, Production and Exploitation.] *Ibid.*, July, pp. 90-99. [1889.]
7956. — [Apparatus for Burning Petroleum.] *Ibid.*, Aug.-Sept., pp. 66; 13 pls. [1889.]
7957. — [Lubricating Oil.] *Ibid.*, Dec., pp. 25; 3 pls. [1889.]
7958. — Berichte der Prüfungscommission über die VIII Section der Ausstellung für Beleuchtungsgegenstände und Naphtaindustrie in St. Petersburg. 1890.
7959. **Vasilev, E.** [Russian Mining Industry in 1883.] 2 vols. 8vo, *St. Petersburg*, 1885.
7960. **Vasquez**, — Analyse einer dem Erdpech ähnlichen Substanz gefunden in einer Höhle bei Catemu in Chile. *Zeitschr. ges. Nat.*, bd. xxi, pp. 447-449. [1863.]
7961. **Vaubel, W.** Ueber die Bestimmung von Petroleum, Petroleumdestillaten und Benzol im Terpentintöl, Kiemenöl und in Terpentintölersatzmitteln. *Chem.-Zeit.*, bd. xxx, p. 757. [1906.]
7962. **Vaughan, F. W.** Bitumen in Cuba. *Eng. Min. Journ.*, vol. lxxiii, pp. 344-347. [1902.]
7963. — The Asphalt Deposits of Western Texas. *Ann. Rep. U.S. Geol. Surv.*, vol. xviii, pt. v, pp. 930-935. [1897.]
7964. — Uvalde, Texas. *Fo. 64, U.S. Geol. Surv.*, 1900.
- Vaughan, T. W.**, see **Hayes, C. W.**; **Hill, R. T.**; and **Parker, E. W.**

7965. **Vauquelin, L. N.** Sur le Bitumen contenu dans les Mines de Soufre. *Ann. Chim. Phys.*, sér. 2, t. xxv, pp. 50-52. [1824.]
7966. **Veatch, A. C.** The Shreveport Area. *Rep. Geol. Surv. Louisiana*, 1899, pp. 148-208, pls. xiv-xviii. [1900.]
7967. ——— The Five Islands—Belle Isle, Côte Blanche, Grande Côte, Petite Anse, Côte Caroline, Attakapas Prairie. *Ibid.*, pp. 209-262. [1900.]
7968. ——— Coal and Oil in southern Uinta County, Wyo. *Bull. U.S. Geol. Surv.*, no. 285, pp. 331-353, pls. x-xii. [1906.]
7969. ——— Geography and Geology of a portion of southwestern Wyoming, with special reference to Coal and Oil. *Prof. Papers U.S. Geol. Surv.*, no. 56. Pp. vi, 178; 26 pls. [1907.]
- Veatch, A. C.**, see **Fuller, M. L.**
7970. **Veatch, J. A.** Notice of a Visit to the "Mnd Volcanoes" in the Colorado Desert. *Proc. Calif. Acad. Sci.*, vol. i, pp. 116-121. [1857.]
7971. **Vecchia, D. & Co.** Il Petrolio e la Paraffina in Italia. 1905.
7972. **Vecqueray, —** Reports on the Trade of Cadiz for the years 1897, 1898. *Dipl. Cons. Rep.*, ann. ser., nos. 1958, 2406. [1898, 1899.]
7973. **Vehrigs, —** Ueber Thon als Entfärbungsmittel für Paraffin. *Polyt. Journ.*, bd. cclxx, pp. 182-186. [1888.]
7974. **Veillet-Dufrêche, —** Les Sources de Pétrole de l'Asie Centrale. *Ann. Mines*, sér. 10, t. i, pp. 611, 612. [1902.]
7975. **Veith, A.** Verfälschung von Petroleum. *Polyt. Journ.*, bd. cclxv, p. 45. [1887.]
7976. ——— Einiges zur Mineralschmierölfabrikation. *Chem.-Zeit.*, bd. xiv, pp. 901, 902. [1890.]
7977. ——— Beiträge zur Bildung des Erdöles. *Ibid.*, p. 1368. [1890.]
7978. ——— Geschichte der Erdölindustrie. *Ber. oesterr. Chem. Ges.*, 1890, p. 6.
7979. ——— Ueber Erdöltrübung. *Polyt. Journ.*, bd. cclxxvii, pp. 567-571. [1890.]
7980. ——— Ueber Benzinerzification. *Ibid.*, bd. cclxxii, pp. 159-161; bd. cclxxxiv, pp. 301, 302. [1891, 1892.]
7981. ——— [Origin of Petroleum.] *Ber. Oesterr. Ges. Chem. Ind.*, April 4, 1891.
7982. ——— Das Erdöl und seine Verarbeitung. 8vo, *Brunswick*, 1892.
7983. ——— [Mineral-Oil Residue Fuel for Locomotives.] *Vasut. Hajoz. Hétlap*, evk. lii, nos. 26-27. [1901.]
7984. **Veith, A., and C. Schestopal.** Die Erdölabballe und ihre Verwerthung für die Sodaerzeugung. *Polyt. Journ.*, bd. cclxxix, pp. 21, 22. [1891.]
7985. ——— Zur Erdölbildung. *Ibid.*, bd. cclxxxii, pp. 136-138. [1891.]
- Velejinski, B.**, see **Beilstein, F. F.**
7986. **Velheim, F. W. W. v.** Ueber ein bisher wenig beachtetes Vorkommen von Bergtheer in Nord-Deutschland. *Arch. Min. Geogn.*, bd. xii, pp. 174-177. [1839.]
7987. **Venable, F. P.** on the Bromination of Heptane. *Amer. Chem. Journ.*, vol. x, pp. 237-239. [1883.]
7988. **Venator, —** Das Petroleumvorkommen im Elsass. *Zeitschr. Ver. deutsch. Ing.*, bd. xxxvi, pp. 47-50. [1892.]
7989. **Vender, V.** Sul Petrolio di Salsomaggiore. *Rend. R. Ist. Lomb.*, sér. 2, vol. xxvii, pp. 760-764. [1891.]
7990. ——— Il Petrolio di Salsomaggiore. *Rev. Sci. Ind.*, vol. xxvii, p. 14. [1897.]
7991. **Venegas, M.** [A Natural and Civil History of California, containing an accurate Description of that Country.] 2 Tt., *Madrid*, 1758.
7992. **Venton-Duclaux, —** Dispositifs destinés à écarter les dangers d'un combustible volatil à bord d'une embarcation. *Journ. Pét.*, t. ix, pp. 21-28, 43-45, 54-59. [1909.]
7993. **Verukov, —** Sur de nouvelles Sources de Pétrole au Caucase [Anaklia]. *Compt. Rend.*, t. cxxvi, p. 1740. [1898.]
7994. **Verbeek, R. D. M.** Geologische Beschrijving der Distrikten Riam Kiwa en Kanan in de zuider-oester-afdeeling van Borneo; volgens opening in de jaren 1869 en 1870. *Jaarb. Mijnie. Ned. O.-Ind.*, jg. iv, dl. 1, pp. 1-130, maps and pls. [1875.]
7995. ——— Topographische en geologische beschrijving van zuid Sumatra, bevattende de Residentien Bengkoelen, Palembang en de Lampongsche Distrikten. *Ibid.*, jg. x, dl. 1, pp. 3-215, 20 pls. [1881.]
7996. ——— Topographische en Geologische Beschrijving van een gedeelte van Sumatra's Westkust. 8vo, *Batavia*, 1883. Atlas fol. *Amsterdam*, 1883.
7997. **Verbeek, R. D. M., and R. Fennema.** Description Géologique de Java et Madoura. 8vo, *Amsterdam*, 1896.
7998. **Verchère, A. M.** Kashmir, the Western Himalaya, and the Afghan Mountains, a geological paper, with a note on the fossils by **M. Edouard de Verneuil**. *Journ. As. Soc. Beng.*, vol. xxxv, pt. 2, pp. 89-133, 159-203; vol. xxxvi, pt. 2, pp. 9-50, 83-114, 201-229. [1866, 1867.]
7999. **Verhellouw, H. J.** Die Bruderladen in Galizien. *Napha*, bd. xiii, pp. 315, 316. [1905.]
8000. **Vermaud, P.** Les Moteurs à Gaz et à Pétrole. (Encycl. scient. des Aides-Memoire). 8vo, *Paris*, 1894.
8001. **Verneuil, P. E. P. de.** Mémoire géologique sur la Crimée. *Mém. Soc. Géol. France*, t. iv, pp. 1-36. [1838.]
- Verneuil, P. E. P. de**, see **Verchère, A. M.**
8002. **Versenev, V.** [Manual of Management of Petroleum-Fired Boilers.] *Moscow*, 1891.
8003. **Versépy, —** Notice sur les causes de l'apparition du Bitume dans la Limagne d'Auvergne. *Ann. Scient. Auvergne*, t. xxv, pp. 456-460. [1852.]
8004. **Vicaire, E.** Sur la Constitution Physique du Soleil dans ses rapports avec la Géologie. *Bull. Soc. Géol. France*, sér. 3, t. ii, pp. 211-219. [1874.]
8005. ——— Les Gisements Pétrolières des Etats-Unis. *Bull. Soc. Ind. Min.*, sér. 4, t. iv, pp. 631-849; 5 pls.: t. vii, pp. 433-488; 3 pls. [1905, 1907.]
8006. **Vidal, L. M.** Reseña Geologica y Minera de la Provincia de Gerona. *Bolet. Com. map. geol. Españ.*, t. xiii, pp. 209-380. [1866.]
8007. **Videky, L.** Asfaltan, dess förekomst, beredning och användning inom tekniken. *Tekn. Tidskr.*, ärg. liii, pp. 111-114, 139-149. [1873.]
- Vieille, —**, see **Berthelot, M.**
8008. **Vigne, G. T.** Personal Narrative of a Visit to Ghuzni, Kabul, and Afghanistan, and a Residence at the Court of Dost Mohamed. 8vo, *London*, 1840.
8009. ——— Travels in Kashmir, Ladak, Iskardo, the countries adjoining the mountain course of the Indus, and the Himalaya north of the Punjab. 2 vols. 8vo, *London*, 1842.
8010. **Vignon, L.** Formation de carbures d'hydrogène à partir de l'oxyde de carbone. *Bull. Soc. Chim. Paris*, sér. 4, t. ix, pp. 18-20. [1911.]
8011. ——— La genèse du pétrole. *Journ. Pét.*, t. xi, pp. 165-167. [1911.]
8012. **Vilenius, G.** [Asphalt and its Surrogates.] *Gorn. Journ.*, 1885, t. 4, pp. 124-133.
8013. **Vilenius, I.** [Rock-tar and its Surrogates.] 8vo, *Kazan*, 1886.
- Villalonga, J. A.**, see **Hauthal, R.**
8014. **Villard, P.** Sur quelques nouveaux hydrates de gaz. *Compt. Rend.*, t. cvii, pp. 1602, 1603. [1888.]
8015. ——— Sur les hydrates de methane et d'éthylène. *Ibid.*, t. cvii, pp. 395-397. [1888.]
8016. **Villarello, J. D.** Estudio de la Teoria quimica propieta por el Sr. D. A. Almaraz, para explicar la Formacion del Petroleo de Aragon (Mex.). *Paperg. Inst. Geol. Mex.*, t. i, pp. 95-111. [1904.]

8017. **Villarejo, J. D.** Algunas Regiones Petrolíferas de Mexico. *Bol. Inst. Geol. Mexico*, no. 26. Pp. 120; 3 pls. 1908.
8018. — El Pozo de Petroleo de Dos Bocas. *Parerg. Inst. Geol. Mexico*, t. iii, pp. 5-112, pls. i-xxvii. [1909.]
8019. — Zonas probables de acumulacion del petroleo, en el subsuelo de las mejores regiones petrolíferas de Mexico. *Bol. Soc. Geol. Mexicana*, t. vii, pp. 23-30. [1910.]
8020. **Villari, L.** Fire and Sword in the Caucasus. 8vo, London, 1905.
8021. **Villavecchia, V., and G. Fabris.** Studi e ricerche sugli olii minerali lubrificanti adoperati in Italia. *Publ. Labor. Chim. Gabelle*, 1891.
8022. **Villon, A. M.** Les Corps Gras. Huiles, beurres, graisses, suifs, cires, corps gras minéraux. 8vo, Paris, 1890.
8023. — L'Éclairage, le Chauffage et la Force Motrice par les hydrocarbures lourds. 8vo, Paris, 1892.
- Villot, —**, see **Combes, —**.
8024. **Viner, N.** [Present Condition of Petroleum Firing in Russia.] *Gorn. Journ.*, 1889, t. 4, pp. 353-393.
8025. **Viola, C.** La Valle del Sacco e il Glacimento d'Asfalto di Castro del Volsci in Provincia di Roma. *Boll. R. Com. Geol. Ital.*, vol. xxvi, pp. 136-143. [1895.]
8026. **Virey, J. J.** Description de l'Atch-Gau, source de feu, ou de Naphte enflammée, près de Bakou, dans la Perse Septentrionale, et des autres sources de Bitume de la presqu'île d'Apcheron. *Journ. Pharm.*, t. vi, pp. 209-215. [1820.]
8027. — Recherches d'Histoire Naturelle sur l'Asphalte, dit Mumie Minérale, ou Bitume de Judée des anciens et des modernes. *Ibid.*, t. viii, pp. 235-241. [1822.]
8028. **Virlet d'August, T.** Sur les Sources et Mines d'Asphalte ou Bitume Minéral de la Grèce et de quelques autres contrées. *Bull. Soc. Géol. France*, t. iv, pp. 203-211. [1834.]
8029. — Nouvelles notes relatives à l'origine volcanique des bitumes minéraux. *Ibid.*, pp. 372-376. [1834.]
8030. — [Bituminous Shales of Antun.] *Ibid.*, sér. 2, t. v, pp. 369, 370. [1848.]
8031. — Notice sur les Bitumes. (Dictionnaire pittoresque d'Histoire Naturelle.) 8vo, Paris, n.d.
8032. **Vizern, —**, and **C. Nicolas.** Dosage des graisses dans la vaseline. *Journ. Pharm. Chim.*, sér. 5, t. xxiv, pp. 49-51. [1891.]
8033. **Vlaanderen, C. L.** Petroleum uit de bron Tjibodas-Tangat in het distrikt Madja, afdeling Madjalengka, Residentie Cheribon. *Jaarb. Mijnw. Ned. O.-Ind.*, jg. i, dl. 1, pp. 273-275. [1872.]
8034. **Völckel, C.** Ueber den Asphalt aus dem Canton Neuenburg. *Ann. Chem. Pharm.*, bd. lxxxvii, pp. 139-148. [1853.]
8035. **Vöelcker, A.** Analysis of the Anthracite of the Calton Hill, Edinburgh. *Edinb. N. Phil. Journ.*, vol. xviii, pp. 333-337. [1850.]
8036. **Völkel, —** Ueber Euplon. *Verh. Schweiz. Ges. Nat.*, 1850, pp. 112, 113.
8037. **Völkner, —** Geographischer Bericht über die Naphtha- und Salz-Gewinnung und den Vertrieb dieser Artikel in dem Turkomanischen Gebiete vom Golfe von Astrabat bis zum Vorgebirge Tjkaraga an der Ostküste des Kaspischen Meeres (*Russ. Bergwerks Journ.*). *Ann. Erdk.*, bd. xviii, pp. 79-87. [1833.]
- Vorckel, R.,** see **Hühner, B.**
8038. **Vogel, A.** Ueber die Zusammensetzung des künftigen Benzol. *Polyt. Journ.*, bd. cxlviii, 68-74. [1858.]
8039. — Einige Anwendungen des Paraffins zu chemischen Zwecken. *Ibid.*, bd. cxliii, p. 139. [1862.]
8040. — Ueber das Verhalten des künftigen Paraffins zu einigen Lösungsmitteln. *Ibid.*, bd. cxliv, p. 221. [1862.]
8041. **Vogel, A.** Beurtheilung des Amerikanischen Petroleum und einiger Solarörsorten. *Polyt. Journ.*, bd. cxlvii, pp. 225-227. [1863.]
8042. — Münchener Beleuchtungsmaterialien *Kunst-Gewerbe-Bl.*, bd. xlix, pp. 96-102. [1863.]
8043. **Vogel, H. A. F. de.** Kajangan-api of vuurwvellen van Bodjonegoro in de residentie Rembang. *Nat. Tijdschr. Ned. Ind.*, dl. xvi. [1858.]
8044. **Vogel, O.** Beiträge zur Geschichte des Erdöls. — I. Ein Besuch Bakus und des heiligen Feuers im Jahr 1733. II. Die Anfänge der Erdölgewinnung im ehemaligen Fürstenthum Lüneburg. III. Erdölgewinnung am Osmundsberge in Schweden. IV. Petroleum in der Fachliteratur des 18 Jahrhunderts. *Petroleum Zeitschr.*, bd. v, pp. 378-380, 445, 446, 515-517, 571, 572. [1910.]
8045. **Vogt, —** Erdöl als Mittel gegen den Kesselstein. *Jahresb. Berg-Dampf-Rev. Vereins.* [1894.]
8046. **Vohl, E. H. L.** Die Producte der trockenen Destillation des Torfes (Oldenburger und Hannoveraner Stichtorf) und deren Verwendung als Beleuchtungsmaterialien. *Polyt. Journ.*, bd. cxl, pp. 63-72. [1856.]
8047. — Ueber Destillationsproducte des Blätterschiefers und der Braunkohle. *Journ. prakt. Chem.*, bd. lxvii, pp. 418-420. [1856.]
8048. — Ueber die Producte der trockenen Destillation des Rheinischen Blätterschiefers (Schiste bitumineux), der Sachsischen sowie der Thüringischen Braunkohle, und die Anwendung derselben als Beleuchtungsmaterialien. *Ann. Chem. Pharm.*, bd. xcvi, pp. 9-18; bd. cxviii, pp. 181-188; bd. cii, pp. 283-308; bd. cvii, pp. 46-48. [1856-1858.]
8049. — Ueber die Destillationsproducte der Braunkohle und des Torfs. *Journ. prakt. Chem.*, bd. lxviii, pp. 504-508; bd. lxxv, pp. 289-298. [1856, 1858.]
8050. — Russischer Torf. Untersuchung der Producte der trockenen Destillation des Torfes von Rostockina (Dorfschaft auf der Wege von Moskau nach Puschkina) und die Verwendung dieser Producte zu industriellen Zwecken. *Polyt. Journ.*, bd. cxliv, pp. 444-447. [1857.]
8051. — Ueber die Verwendung des in Württemberg vorkommenden Posidonienschiefers zur Bereitung ätherischer Beleuchtungsmaterialien. *Ibid.*, bd. cxlv, pp. 47-50. [1858.]
8052. — Uebersicht des Procentgehalts bituminöser Fossilien an Beleuchtungsstoffen. *Ibid.*, pp. 51, 52. [1857.]
8053. — Untersuchung des östindischen Erdöls und die Verwendung desselben zur Darstellung von Photogen und Paraffin. *Ibid.*, bd. cxvii, pp. 374, 375. [1858.]
8054. — Untersuchung verschiedener bituminöser Fossilien bezüglich deren Verwendung zur Darstellung von Beleuchtungsmaterialien. *Ibid.*, bd. cxii, pp. 306-310. [1859.]
8055. — Ueber den Einfluss, welchen die Erzeugungsart des Theeros auf dessen Gehalt an Photogen, Paraffin, Creosot, etc., ausübt. *Ibid.*, pp. 390-392. [1859.]
8056. — Zur Geschichte der Photogen- und Paraffin-Industrie. *Ibid.*, bd. cxii, pp. 376-392. [1861.]
8057. — Ueber den Schwefelgehalt verschiedener ätherischer Beleuchtungsmaterialien. *Ibid.*, bd. cxviii, pp. 49-51. [1863.]
8058. — Die trockene Destillation bituminöser Fossilien behufs Darstellung fester und flüssiger Köhlenwasserstoffe, welche als Beleuchtungsmaterialien sowohl, wie zu Maschinenschmieren und Darstellung von Farben benutzt werden. *Polyt. Journ.*, bd. cixxii, pp. 459-472. [1864.]
8059. — Ueber die Zersetzung der schwerer Mineralöle aus Braunkohlen, Torf, bituminösen Schiefen, Petroleum, und zur Erzeugung leichteren (wasserstoffreicherer) Beleuchtungsöle. *Ibid.*, bd. clxxv, pp. 58-76. [1865.]
8060. — Die fractionirte Destillation bei constantem Niveau behufs der Trennung der in den Erd- und Theorien enthaltenen Kohlenwasserstoffe zur Erzielung einer grösseren Brennöl-Ausbeute. *Ibid.*, bd. clxxvii, pp. 133-139. [1865.]

8061. **Vohl, E. H. L.** Anwendung des gereinigten Paraffins zum Präparieren von Wein- und Bierfäfern. *Polyt. Journ.*, bd. clixviii, pp. 68, 69. [1865.]
8062. ——— Flur- und Schwefelsäureverbindungen als Verunreinigungen des im Handel vorkommenden Photogens und Paraffinöls. *Ibid.*, bd. clixviii, pp. 396-399. [1866.]
8063. ——— Mittheilungen über die Verwendung des Torfes zu Leucht- und Schmiermaterialien. *Jahresb. chem. Technol.*, bd. xiii, pp. 727-734. [1867.]
8064. ——— Emplois nouveaux de la Paraffine. *Journ., Eclair. Gaz.*, t. xix, p. 58. [1871.]
8065. ——— Application des schistes liasiques bitumineux des formations jurassiques des Pyrénées occidentales, à la préparation des matières propres à l'éclairage et au graissage. *Ibid.*, pp. 72, 73. [1871.]
8066. ——— Ueber das Petroleum als Beleuchtungsmaterial, seine Verunreinigungen, etc. *Polyt. Journ.*, bd. ccxvi, pp. 47-51. [1875.]
8067. **Voigt, J. C. M.** Kleine mineralogische Schriften. 8vo, Weimar, 1799.
8068. **Voislav, S. G.** [Organisation of Pipe-Lines.] *Zap. Imp. Russk. Tekhn. Obsch.*, g. xiii, otd. 1, pp. 237-274. [1879.]
8069. ——— Pseudo-Schlittungen bei Spülbohren. *Naphta*, bd. x, pp. 129, 130. [1902.]
8070. **Voit, F. W.** Geologisch-bergmännische Reise-skizzen aus Borneo (Kutei und Pasir). *Berg-Hütt. Zeit.*, bd. lviii, pp. 457-459. [1899.]
8071. **Voitech, V.** Die Vorgänge zum Belichten des Asphalt. *Phot. Corr.*, bd. xliii, pp. 284, 285. [1906.]
8072. **Volarovitch, P. E.** [Geology of the Kuba District.] *Bull. Com. géol. Russ.*, t. xxiii, pp. 265-288, pl. vi. [1904.]
8073. ——— [Kirmaku Oilfield, Apscheron. *Ibid.*, t. xxviii, pp. 561-595, pl. xviii. [1909.]
8074. **Volarovitch, P. E.**, and **D. V. Golubjatnikov.** [Detailed Structure of the Balakhani-Sabuntchi Oilfield.] *Ibid.*, t. xxvii, Journ., pp. 3-6. [1908.]
8075. **Voldere, G. de.** Études sur l'analyse des Gaz a propos du traite pratique de l'analyse des Gaz de M. Berthelot. *Mon. Sci.*, t. lxvii, pp. 289-301. [1908.]
8076. **Volger, G. H. O.** Der Schlefer und seiner Bedeutung für Württemberg.
8077. ——— Versuch einer Monographie des Borazites. 8vo, Hanover, 1855.
8078. **Volkov, P.** [Illumination by Carbuiretted Air.] *Tekhn. Sborn.*, t. xii, pp. 166-170. [1871.]
8079. **Vollert, M.** Der Braunkohlenbergbau im Oberbergamtsbezirk Halle, und in den angrenzenden Staaten. Halle, 1890.
8080. **Volta, A.** Sull' aria infiammabile nativa degli paludi. *Milán*, 1777.
8081. ——— Sopra i fuochi dei terreni e delle fontane ardenti in generale e sopra quelli di Pietra Mala in particolare. *Mem. Soc. Ital. Mat. Fis.*, vol. ii, pp. 662-676, 900-907. [1784.]
8082. **Voltz, P. L.** Ueber Lobsann, Thionville, und Gundershofen. *Taschenb. Min.* bd. xix, p. 355. [1825.]
8083. ——— Ueberblick der Mineralien der beiden Rhein Departamente. *Strasburg*, 1828?
8084. **Volz, W.** Beiträge zur geologischen Kenntniss von Nord-Sumatra. *Zeitschr. deutsch. geol. Ges.*, bd. li, pp. 1-61, pl. v. [1899.]
8085. **Vorontsov-Velyaminov, —.** [Description of the Baku Roadstead. Progress of Improvements of Quays and Harbour, and local building materials.] *Inj. Journ.*, 1867, pp. 287-312, pl. 2.
8086. **Voskoboinikov, —.** [Mineralogical Notice of the Apscheron Peninsula, forming the Baku District.] *Gorn. Journ.*, 1827, kn. ix, pp. 17-55.
8087. **Voskoboinikov, —,** and **— Guriev.** [Geological Description of the Taman Peninsula, belonging to the Black Sea Military Lands.] *Ibid.*, 1832, t. 1, pp. 21-71.
8088. **Vosmaer, A.** Das System Öl-Wasser. *Chem. Weekblad*, bd. vii, p. 539. [1910.]
8089. **Vosnesenski, —.** [Petroleum-Firing.] *Kiev*, 1882.
8090. **Vournazos, A.** L'asphalte grecque au point de vue industriel. *Compt. Rend. Congr. internat. Chim. Appl.*, sess. 6. t. lii, pp. 232-243. [1907.]
8091. **Vredenburg, E. W.** Report on the Geology of Sarawak, Jhalawan, Mekran, and the State of Las Bela, considered principally from the point of view of Economic Development. *Rec. Geol. Surv. Ind.*, vol. xxxvii, pp. 189-215, pls. viii-xii. [1909.]
8092. **Vuillemain.** Statistique Agricole Industrielle et Commerciale de l'arrondissement de Douai.
8093. **Vukotinic, L. v.** Das Moslaviner Gebirge in Croatien. *Jahrb. k.-k. geol. Reichs.*, bd. iii, no. 2, pp. 92-95. [1852.]
8094. **W** ——— Das Leitungsvermögen des Benzins und des Wassers. *Elektrotechn. Zeitschr.*, bd. xxv, pp. 34, 35. [1906.]
8095. **W** ———, **G. E.** The Shrinkage of Natural Gas. *Sci. Amer.*, vol. lxxxv, p. 6. [1901.]
8096. **W** ———, **M.** Turkestan Oil Field. *Petrol. World*, vol. viii, p. 40. [1911.]
8097. **W** ———, **O.** Schieferöl in Australien. *Seifenfabrik.*, bd. xxiv, pp. 203, 204. [1904.]
8098. **Wachtel, H.** Die Naphta und deren Industrie in Ostgalizien vom Standpunkte des Bergregals. *Oesterr. Zeitschr. Berg-Hütt.*, bd. viii, pp. 129-131. [1860.]
8099. **Wackenroder, H.** Ueber eine besondere Art erdiger Braunkohle und das darin enthaltene wachsartige Fett. *Arch. Pharm.*, bd. cx, pp. 14-27. [1849.]
8100. **Wagenmann, P.** Procédé pour la fabrication des hydrocarbures et de la paraffine. *Technol.*, t. xvi, pp. 463, 464. [1855.]
8101. ——— Ueber die Destillation des Photogens und Paraffinöls im Vacuum. *Polyt. Journ.*, bd. cxxxix, pp. 43-48. [1856.]
8102. ——— Destillationsproducte verschiedener Rohmaterialien zur Gewinnung von Photogen und Paraffin. *Ibid.*, bd. cxlv, pp. 309, 310. [1857.]
8103. ——— Ueber neue, in Schottland vorkommende Rohmaterialien zur Photogen- und Paraffin fabrication. *Ibid.*, bd. cii, pp. 116-119; bd. ciii, p. 113. [1859.]
8104. ——— Reisenotizen [zu London.] *Journ. Gasbeleuchtung*, 1859, p. 124.
8105. **Wagner, —.** Ueber das Vorkommen von Hatchettin zu Wettin. *N. Jahrb.*, 1864, pp. 687-689.
8106. **Wagner, A.** Kritische Untersuchungen über den Werth von Naphthalin und Petroleum als Ersatzmittel für Cannel-Kohle, bei der Gasfabrikation. *Polyt. Journ.*, bd. ccxvi, pp. 250-257. [1875.]
8107. ——— Der Werth von Petroleum und Steinkohlentheer zur Gaserzeugung. *Ibid.*, bd. ccxvii, pp. 64-69. [1875.]
8108. ——— Ueber Prüfung des Petroleums auf dessen Feuergefährlichkeit. *Bayr. Ind. Gewerbbil.*, 1879, pp. 82-97.
8109. **Wagner, F. M.** Bemerkungen über das Braunkohlenlager zu Wildshut im Oesterreichischen Innviertel. *Efem. Berg. Hütt.*, bd. iv, pp. 17-30. [1808.]
8110. **Wagner, G.** Ueber die Oxydation der Olefine und der Alkohole der Allylkoholreihe. *Ber. deutsch. chem. Ges.*, bd. xxi, pp. 1230-1240. [1883.]
8111. ——— Ueber die Oxydation der Kohlenwasserstoffe  $C_nH_{2n-2}$ . *Ibid.*, pp. 3343-3346. [1883.]
8112. ——— Zur Oxydation ungesättigter Verbindungen. *Ibid.*, pp. 3347-3360. [1888.]
- Wagner, G.**, see **Sohncke, L.**
8113. **Wagner, H. A.** Auxiliary Oil Firing in Steam Boiler Plants. *Mech. Eng.*, vol. xxviii, pp. 28, 29. [1911.]
8114. **Wagner, J. R. v.** Ueber künstliches Bittermandelöl aus Steinöl. *Polyt. Journ.*, bd. cxxxvi, p. 311. [1855.]
8115. ——— Theorie und Praxis der Gewerbe. Hand- und Lehrbuch der Technologie. VI Bde. 8vo, Leipzig, 1858-1864.

8116. **Wagner, J. R. v.** Ueber eine hydrostatische Prüfungsmethode des Bienenwachses auf Paraffin. *Zeitschr. anal. Chem.*, bd. v, pp. 279-285. [1866.]
8117. ——— Ermittlung des Stearin-Säure im kauslichen Petroleum. *Polyt. Centr.*, bd. xxxiii, p. 1151. [1867.]
8118. ——— Ueber das Geheimmittel Vaseline. *Polyt. Journ.*, bd. cxxdiii, pp. 515-517. [1877.]
8119. **Wagner, M.** Reise nach Persien und dem Lande der Kurden. 2 Bde. *Leipzig*, 1852.
8120. ——— Das Petroleum oder Steinöl in Canada. *Zeitschr. allg. Erdk.*, bd. xii, pp. 279-292. [1862.]
8121. **Wagoner, L.** The Geology of the Quicksilver Mines of California. *Eng. Min. Journ.*, vol. xxxiv, p. 334. [1882.]
8122. **Wahl, A. v.** Versuch einer geologischen Erklärung der Erdölbildung. *Vulkan*, bd. ii, pp. 45, 46, 53, 54. [1904.]
8123. **Wahl, W. H.** The Light Petroleum Oils considered as to their safety or danger in various domestic uses. *Journ. Franklin Inst.*, vol. xcv, p. 267. [1879.]
8124. **Waitzenbreier, —, and — Sivkoff [=J. Sintsov].** Le Pétrole dans les Gouvernements di Samara, Simbirsk et Kazan (Russie orientale). *Rev. Univ. Mines*, sér. 2, t. ii, pp. 291-294. [1877.]
8125. ——— [Oil Belt of Central European Russia belonging to Schandor. Report of W. and S. on the new fuel, "Solid Petroleum."] *St. Petersburg*, 1878.
8126. **Wakashina, K.** [Japanese Petroleum, 1894.] Quoted in *Ann. Rep. U.S. Geol. Surv.*, vol. xvi, pt. iv, pp. 399-402. [1895.]
8127. **Walden, I. P.** [On the Origin of Petroleum.] *Jurn. Russk. Fiz. Khim. Obsch.*, t. xxxvi, otd. 1, pp. 607-611. [1904.]
8128. **Walden, P.** Fünfundzwanzig Jahre stereochemischer Forschung. *Nature, Rundschau*, bd. xv, pp. 145-148, 157-160, 169-173, 185-188, 197-199. 1900.
8129. ——— Optische Aktivität und Entstehung des Erdöls. *Chem.-Zeit.*, bd. xxx, pp. 391-393, 1155-1158, 1167-1170. [1906.]
8130. **Waldie, D.** On Burmese Paraffine. *Proc. As. Soc. Beng.*, 1866, pp. 72, 73.
8131. **Waldron, F. W.** On the Appearance and Disappearance of a Mud Island at Wallfish Bay. *Trans. S. African Phil. Soc.*, vol. xi, pp. 185-188, pls. xxviii-xxxi. [1901.]
- Walizer, A.**, see **Gniewosz, S.**
8132. **Walker, E. H. R.** Report for 1887-1891 on the Trade of Corunna. *Dipl. Cons. Rep.*, ann. ser., nos. 329, 520, 711, 914, 1056. [1888-1892.]
8133. ——— Report for 1896 on the Philippine Islands. *Ibid.*, no. 1932. [1897.]
8134. **Walker, J. B.** Panola, Rusk, Nacogdoches and Cherokee Counties. *2nd Ann. Rep. Geol. Surv. Texas*, pp. 225-243, 255-267, 268-286, 287-302, pl. iii. [1891.]
8135. **Walker, P. F.** Stability of an Oil-Tank Steamer. *Marine Engineering*, vol. vii, pp. 492-495. [1902.]
8136. **Walker, T. L.** The Crystalline Symmetry of Torbanite. *Amer. Journ.*, ser. 4, vol. vi, pp. 41-44. [1898.]
8137. **Walker, W.** Petroleum in North Staffordshire. *Petrol. Rev.*, vol. xxiv, p. 301. [1911.]
8138. **Wall, G. P.** On the Geology of a Part of Venezuela and Trinidad. *Quart. Journ. Geol. Soc.*, vol. xvi, pp. 460-470, pl. xxi. [1860.]
8139. ——— The Origin of Bitumen. *Geol. Mag.*, vol. lii, pp. 236-239. [1866.]
8140. **Wall, G. P., and J. G. Sawkins.** Report on the Geology of Trinidad. 8vo, *London*, 1860.
8141. **Wall, M.** Some Observations on the Phenomena which take place between Oil and Water. *Mem. Lit. Phil. Soc. Manch.*, vol. ii, pp. 435-444. [1789.]
- Wallace, E. C.**, see **Richardson, C.**
8142. **Wallace, H. V.** Oilfields of the Trans-Pecos Region (Texas). *Min. Sci. Press.*, vol. ciii, pp. 260-262. [1911.]
8143. **Wallace, H. V.** The Toyah Oil Fields of Reeves County, Texas. *Mining Eng. World*, vol. xxxv, pp. 153, 154. [1911.]
8144. **Wallace, W.** Report on Mineral Oils for Lubrication. *Amer. Chem.*, vol. liii, p. 66. [1872.]
8145. **Wallach, O.** Zur Kenntniss der Terpene und der ätherischen Oele. *Ann. Chem. Pharm.*, bd. cccxxvii, pp. 277-302. [1855.]
8146. **Waller, E.** Notes on the Petroleum of Azua, St. Domingo. *Amer. Chem.*, vol. ii, pp. 220, 221. [1871.]
8147. **Waller, G. A.** Report on the Recent Discovery of Cannel Coal in the Parish of Proleouna and upon the New Victory Copper Mine, near Arthur River, Tasmania. *Rep. Sec. Mines Tasm.*, 1900-1901, pp. 77-89, pl. [1901.]
8148. **Wallerius, J. G.** Mineralogi. *Stockholm*, 1747.
8149. ——— Hydrologie, ou Description du Règne Aqueux. . . . *Paris*, 1751.
- Walpole, R.**, see **Hawkins, —.**
8150. **Walsh, G. E.** Gas Fuels for Modern Engines. *Iron Age*, Jan. 29, 1903, pp. 4, 5.
8151. **Walter, B.** Die Erzlagerstätten der südlichen Bukowina. *Jahrb. k.-k. geol. Reichs.*, bd. xxvi, pp. 243-426. [1876.]
8152. ——— Die Chancen einer Erdölgewinnung in der Bukowina. *Ibid.*, bd. xxx, pp. 115-148. [1880.]
8153. **Walter, E.** Der entleuchtete Heizbrenner für Gase und flüssige Brennstoffe. 8vo, *Halle a. S.*, 1909.
8154. **Walter, H.** Project zur Untersuchung der erdölführenden Schichten in Galizien mittelst tiefer Schächte und Querschläge. *Oesterr. Zeitschr. Berg-Hütt.*, bd. xxvii, pp. 397-399, 411-413. [1879.]
8155. ——— Ein Durchschnitt in den Mittelkarpathen von Chrowy über Uherce und den ungarischen Grenzkanal bis Sturicza, mit Berücksichtigung einiger Paralleldurchschnitte. *Jahrb. k.-k. geol. Reichs.*, bd. xxx, pp. 635-650. [1880.]
8156. ——— Geschichtliche Skizzen der Petroleum-Industrie Galiziens. *Oesterr. Zeitschr. Berg-Hütt.*, bd. xxix, pp. 302-304, 316, 317. [1881.]
8157. ——— Einiges über das canadische Bohrsystem. *Ibid.*, xxxii, pp. 512-515. [1884.]
8158. ——— Vorkommen von Petroleum bei Sósmező, Haromszeker Komitat in Ungarn. *Ung. montan-ind. Zeit.*, 1887.
8159. ——— Gutachten über das Vorkommen von Nafta (Petroleum oder Bergöl) in Zempliner Comitate, namentlich in Kriva-Olyka, und Hankovce. *Ibid.*, no. 15.
8160. ——— Petroleumvorkommen in Körösmező. *Allg. österr. Chem.-Techn.-Zeit.*, bd. x, no. 22. [1892.]
8161. ——— Geologische Studien der Umgebung von Brzostek, Strzyzów, Ropczyce und Dembica. *Kosmos*, 1895.
8162. ——— Ungarische Petroleum-Vorkommen. *Montan-Zeit. Oesterr.-Ungar. Balkanl.*, bd. ii, p. 165. [1895.]
8163. ——— Gutachten über das Vorkommen von Petroleum in Sósmező in Siebenbürgen. *Ibid.*, bd. iii, no. 8. [1896.]
8164. ——— Ein Auszug nach Körösmező. *Allg. österr. Chem.-Techn.-Zeit.*, bd. xiv, nos. 15, 16. [1896.]
8165. ——— Das Naphtaterrain in Zabola, Komitat Haromszék in Siebenbürgen. *Montanzeit. Oesterr.-Ungar. Balkanl.*, bd. v, pp. 23, 24. [1898.]
8166. ——— Das Petroleumterrain in Sósmező, Komitat Haromszék in Siebenbürgen der Herren Fritz Zuska und F. H. Ascher. *Ibid.*, pp. 201, 202. [1898.]
8167. ——— The Origin of the Petroleum Industry in Galicia. *Petrol. Rev.*, vol. vi, pp. 172-174, 227, 228, 256-258. [1902.]
8168. ——— The Valuation of Oil Lands. *Petrol. World* vol. i, pp. 276-278. [1904.]
8169. ——— Petroleum in Ungarn. Körösmező. *Naphta*, bd. xiv, pp. 128, 129. [1906.]
8170. ——— Die Tiefbohrung in Zboró, Sároszer Komitat. *Ungar. Montan-Ind. Zeit.* [1908.]
8171. ——— Ungarische Staatsmonopole. *Org. Ver. Bohrtchn.*, bd. xvii, pp. 261-263, 278, 279. [1910.]

8172. **Walter, H., and E. v. Dunikowski.** Das Petroleumgebiet der galizischen Westkarpathen. 8vo, Vienna, 1883.
8173. **Walter, J.** Ein Beitrag zur Kenntniss des Picens und Petrol. *Basle*, 1881.
8174. ——— Wie liess sich das europäische Erdgas besser verwerten? *Allgem. österr. chem. techn. Zeit.*, bd. xxviii, pp. 177-179, 186, 187; bd. xxix, pp. 3-5. [1910, 1911.]
8175. ——— Eine Beobachtung am Petroleum. *Ibid.*, bd. xxix, pp. 129-131. [1911.]
8176. ——— Welche regelmässigen Beobachtungen fehlen noch zur Kenntniss der Erde? *Org. Ver. Bohrtechn.*, bd., xviii, pp. 62-66, 78-80. [1911.]
8177. **Walter, P.** Note sur un cire fossile de la Galicie. *Ann. Chim. Phys.*, ser. 2, t. lxxxv, pp. 214, 215. [1840.]
- Walter, P., see Pelletier, J.**
8178. **Walther, A.** [Petroleum Progress in Hungary, 1900.] *Ban. Köhász. Lap.*, evf. xxxiv, p. 17. [1901.]
8179. **Walzl, —.** Ueber Petroleumnaphta und seine technische Anwendung. *Bayer. Gewerbe-Zeit.*, 1871, p. 23.
8180. **Wanklyn, J. A.** On Fractional Distillation. *Phil. Mag.*, ser. 4, vol. xiv, pp. 129-133. [1873.]
8181. **Wanklyn, J. A., and W. J. Cooper.** The Method of Fractional Distillation illustrated by the investigation of Kerosene. *Ibid.*, ser. 5, vol. xxxvii, pp. 495-499. [1894.]
8182. ——— A new Class of Compounds of the Inactive Hydrocarbons. *Chem. News*, vol. lxx, pp. 211, 212; vol. lxxi, 250, 251. [1894, 1895.]
8183. ——— On the Nature and Composition of the Commercial Russian Kerosene. *Ibid.*, vol. lxxii, p. 7. [1895.]
8184. ——— Fractional Distillation applied to American Petroleum and Russian Kerosene. *Phil. Mag.*, ser. 5, vol. xi, pp. 225-228. [1895.]
8185. **Wanklyn, J. A., and E. Erlenmeyer.** On the Hexylgroup. *Journ. Chem. Soc.*, vol. xvi, pp. 221-235; vol. xvii, pp. 190-193. [1863, 1864.]
8186. **Warburton, J. W.** Report for 1896 on the Trade of California. *Dipl. Cons. Rep.*, ann. ser., no. 1922. [1897.]
8187. **Ward, C. E.** Oils for Lubrication. The Action of an Oil in Preventing Friction, Qualities Necessary and Methods of Testing. *Mines and Minerals*, vol. xxxii, pp. 26, 27. [1911.]
8188. **Ward, J.** The Geological Features of the North Staffordshire Coalfields; their Organic Remains, their Range and Distribution, with a Catalogue of the Fossils of the Carboniferous System of North Staffordshire. *Trans. N. Staff. Inst. Min. Eng.*, vol. x, pp. 1-189. [1890.]
8189. **Wardrop, O.** Reports for the years 1906-1908 on the Trade of Rumania. *Dipl. Cons. Rep.*, ann. ser., nos. 3787, 4005, 4219. [1907-1909.]
8190. **Warner, A. J.** On the Oil-bearing Rocks of Ohio and West Virginia. *Amer. Journ.*, ser., 3, vol. ii, p. 215. [1871.]
8191. **Warren, C. M.** On a Process of Fractional Condensation applicable to the Separation of Bodies having small differences between their Boiling Points. *Mem. Amer. Acad.*, ser. 2, vol. ix, pp. 121-134. [1865.]
8192. ——— Researches on the Volatile Hydrocarbons. *Ibid.*, pp. 135-176. [1865.]
8193. ——— Report to Prof. Silliman on Assay of Petroleum from Santa Barbara Co., California. *National Intelligencer*, Feb. 7, 1866.
8194. ——— Hydrocarbons of the Pennsylvania Petroleum. *Amer. Journ.*, ser. 2, vol. xiv, pp. 262-264. [1868.]
8195. **Warren, C. M., and F. H. Storer.** Examination of a Hydrocarbon Naptha, obtained from the Products of the Destructive Distillation of Lime-Soap. *Mem. Amer. Acad.*, ser. 2, vol. ix, pp. 177-207. [1865.]
8196. ——— Examination of Naptha obtained from Rangoon Petroleum. *Ibid.*, 208-216. [1867.]
8197. **Warren, F. E.** Reports of the Governor of Wyoming to the Secretary of the Interior, 1885, 1886. 8vo, Washington, 1886, 1887.
8198. **Warren, H. N.** A Simple Electrical Apparatus for determining the Flashing Point of Mineral Oils. *Chem. News*, vol. lxii, p. 311. [1890.]
8199. ——— On the Stability of the Petroleum Compounds. *Ibid.*, vol. lxxv, p. 29. [1892.]
8200. **Warren, P.** Report for 1886 on the Trade of Taiwan (Formosa). *Dipl. Cons. Rep.*, ann. ser., no. 156. [1887.]
8201. **Washburne, C. W.** Gasfields of the Bighorn Basin, Wyoming. *Bull. U.S. Geol. Surv.*, no. 340, pp. 348-363, pl. iii. [1908.]
8202. ——— Development in the Boulder Oil Field, Colorado. *Ibid.*, no. 381, pp. 514-516. [1909.]
8203. ——— The Florence Oil Field, Colorado. *Ibid.*, pp. 517-544, pl. xxiv. [1910.]
8204. ——— Gas and Oil Prospects near Vale, Oregon, and Payette, Idaho. *Ibid.*, no. 431, pp. 22-55, pl. iii. [1911.]
8205. ——— Gas Prospects in Harney Valley, Oregon. *Ibid.*, pp. 56, 57. [1911.]
8206. **Waters, C. E.** Algal Wax and its Relationship to Petroleum. *Amer. Chem. Journ.*, vol. xxviii, pp. 78-82. [1902.]
8207. ——— Action of sunlight and air upon some Lubricating Oils. *Journ. Ind. Eng. Chem.*, vol. ii, pp. 451-454. [1910.]
8208. ——— Behaviour of high-boiling mineral oils on heating in the air. *Ibid.*, vol. iii, pp. 233-237. [1911.]
8209. ——— Effect of added fatty and other oils on the carbonisation of Mineral Lubricating Oils. *Ibid.*, pp. 812-816. [1911.]
8210. **Watkins, A. E.** The Taranaki Oilfield. *Trans. Austral. Inst. Min. Eng.*, June 30, 1911.
8211. **Watson, E. P.** Oil Fuel and Oil Burners. *Iron Age*, May 8, 1902.
- Watson, H. T., see Garry, H. S.**
8212. **Watson, W.** On the Thermal and Combustion Efficiency of a Four-cylinder Petrol Motor. *Proc. Inst. Automob. Eng.*, n.s., vol. lii, pp. 387-428. [1909.]
8213. **Watson, W., and R. W. Fenning.** An Investigation of the Thermal Efficiency of a Two Cycle Petrol Engine. *Ibid.*, vol. v, pp. 83-132. [1911.]
- Watson, W., see Thomas, J. S. G.**
8214. **Watt, A.** The Art of Soap-making. A Practical Handbook of the Manufacture of Hard and Soft Soaps, Toilet Soaps, etc. 8vo, London, 1884.
8215. **Watters, T.** Report on the Trade of Macao and Timor. *Dipl. Cons. Rep.*, ann. ser., no. 1238. [1893.]
8216. **Watts, W. L.** Merced County. 10th Ann. Rep. State Mineral. Calif. for 1890, pp. 323-332. [1890.]
8217. ——— Sacramento County. *Ibid.*, pp. 496-514. [1890.]
8218. ——— San Joaquin County. *Ibid.*, pp. 548-566. [1890.]
8219. ——— San Mateo County. *Ibid.*, pp. 586-594. [1890.]
8220. ——— Santa Clara County. *Ibid.*, pp. 604-619. [1890.]
8221. ——— Santa Cruz County. *Ibid.*, pp. 620-626. [1890.]
8222. ——— Solano County. *Ibid.*, pp. 659-671. [1890.]
8223. ——— Stanislaus County. *Ibid.*, pp. 680-690. [1890.]
8224. ——— Colusa County. 11th Ann. Rep. State Mineral. California, pp. 179-188. [1893.]
8225. ——— Placer County. *Ibid.*, pp. 319-322.
8226. ——— Sonoma County. *Ibid.*, pp. 453-463.
8227. ——— Tulare County. *Ibid.*, pp. 485-492.
8228. ——— The Gas- and Petroleum-yielding Formations of the Central Valley of California. *Bull. Calif. State Min. Bureau*, no. 3, pp. 100, maps and pls. [1894.]

8229. **Watts, W. L.** Petroleum in California. *13th Ann. Rep. State Mineral. Calif.*, pp. 570-593. [1896.]
8230. ——— Oil as Fuel in Los Angeles County. *13th Rep. State Mineral. Calif.*, pp. 662-664. [1896.]
8231. ——— Notes on the Oil-yielding formations of California. *Min. Sci. Press.*, vol. lxxix, pp. 144-146, 172, 173. [1899.]
8232. **Weatherhead, D. L.**, see **Pass, S. W.**
8232. **Webber**, — Zur Tiefbohrung in Körösmezö. *Allg. österr. Chem. Techn.-Zeit.*, bd. x, p. 1397. [1892.]
8233. ——— [Reply to Stavenov.] *Ibid.*, p. 1461. [1892.]
8234. **Webber, W. H. Y.** Petrol-Air Gas Light. *Illum. Eng.*, vol. i, pp. 34-37. [1908.]
8235. **Weber, A. H.** Natural Gas [California]. *7th Ann. Rep. State Mineral. Calif. for 1887*, pp. 179-191. [1888.]
8236. ——— Petroleum and Asphaltum, Northern California. *Ibid.*, pp. 193-202. [1888.]
8237. **Weber, F. C.** Natural Gas Pumping Plant. *Mines and Minerals*, vol. xxv, pp. 582-584. [1905.]
8238. **Weber, R.** Ueber den Anlass zur Explosionen von Petroleum und anderen brennbaren Flüssigkeiten. *Sitz. Ver. Beford. Gewerbst.*, 1881, pp. 119-133.
8239. **Weber, V.** [Preliminary Report on a Journey to Ferghana in 1902.] *Bull. Com. géol. Russ.*, t. xxii, pp. 1-14, pl. 1. [1903.]
8240. ——— Geological Researches in Ferghana, 1909 and 1910. *Ibid.*, t. xxix, pp. 603-695, pls. xiv-xvi. [1910.]
8241. **Weber, V.**, and **K. I. Kalitzki.** [Tobeleken Island.] *Ibid.*, t. xxviii, pp. 139-229, pls. vi-x. [1909.]
8242. **Wedding, H.** Official Catalogue of the Mining and Metallurgical Products (Class I.) in the Zollverein Department of the International Exhibition, 1862. *Berlin*, 1862.
8243. **Wedding, W.** Neuerungen aus Beleuchtungs-technik. *Zeitschr. Ver. deutsch. Ing.*, bd. xviii, pp. 676-678. [1904.]
8244. ——— Ueber die Wirkungsgrad und die praktische Bedeutung der gebräuchlichsten Lichtquellen. *Journ. Gasbeleuch.*, bd. xviii, pp. 1-5, 25-28, 45-49, 65-68, 87-91, 105-112. [1905.]
- Wedekind, R.**, see **Staff, H. v.**
8245. **Wedge, N.** The Concentration of Sulphuric Acid separated from the Sludge Acid from the Acid treatment of Petroleum Products. *Journ. Soc. Chem. Ind.*, vol. xviii, pp. 345, 346. [1899.]
8246. **Weed, E.** Oilshales in Scotland. *Iron and Coal Tr. Rev.*, vol. lxxix, pp. 205, 206. [1909.]
8247. **Weeks, J. D.** The Story of Natural Gas. The Eternal Fire. *Chautauquan*, 1887, pp. 594-597.
8248. ——— Petroleum and Natural Gas. *Min. Res. United States for 1886*, pp. 439-516; *Ibid.* for 1887, pp. 436-502; *Ibid.* for 1888, pp. 442-515; *Ibid.* for 1889 and 1890, pp. 287-372; *Ibid.* for 1891, pp. 403-451; *Ibid.* for 1892, pp. 603-698; *Ibid.* for 1893, pp. 461-541.
8249. ——— Petroleum. *Rep. Min. Ind. U.S.*, 11th Census, 1890, pp. 426-502. [1892.]
8250. ——— Natural Gas. *Ibid.*, pp. 503-578. [1892.]
8251. ——— Petroleum and Natural Gas in 1894. *16th Ann. Rep. U.S. Geol. Surv.*, pt. iv, pp. 315-429. [1895.]
8252. **Wegemann, C. H.** The Salt Creek Oil Field, Natrona County, Wyoming. *Bull. U.S. Geol. Surv.*, no. 452, pp. 56-75, pls. vii-xii. [1911.]
8253. ——— The Powder River Oil Field, Wyoming. *Ibid.*, no. 471a, pt. ii, pp. 56-75, pl. vii. [1912.]
8254. **Weger, M.** Die Handelspetrole. *Chem. Ind.*, bd. xxviii, pp. 24-29. [1905.]
8255. ——— Ueber die Bromzahl von Petroleum. *Petroleum Zeitschr.*, bd. ii, pp. 101, 102. [1906.]
8256. **Wehrlin, C.** Les Moteurs à gaz et les Moteurs à pétrole à l'Exposition Universelle de 1889. 8vo, Paris, 1890.
- Weigert, F.**, see **Luther, R.**
8257. **Weil, F.** 1°. . . 2°. ; Sur les Bitumes de Cuba; 3°. Sur les Huiles de Pétrole de la Pennsylvanie. *Ann. Gén. Civ.*, t. i, pt. 2, pp. 405-408. [1862.]
8258. ——— L'ozokérite ou cire fossile et le pétrole brut d'Afrique. *Technol.*, t. xxxviii, pp. 308-310. [1876.]
8259. ——— Travail analytique et industriel fait sur un Pétrole d'Égypte. *Mon. Sci.*, t. xix, pp. 295-297. [1877.]
- Weilandt, H.**, see **Kraft, F.**
8260. **Weiller, P.** Das Heizöl in Hüttenbetriebe. *Petroleum Zeitschr.*, bd. iiii, pp. 510-514. [1908.]
8261. **Weinberger, R.** Zwei Fälle von Asphyxie durch Einathmen von Petroleumdunst. *Wien. Med. Halle*, bd. iv, p. 40. [1863.]
8262. **Weinstein, L.** Die Bestimmung der Dichte von Paraffin. *Chem.-Zeit.*, bd. xii, pp. 875, 894. [1888.]
8263. ——— Das Erdöl von Peru. *Ibid.*, bd. xvi, pp. 795-798. [1892.]
- Weinstein, L.**, see **Holdé, D.**
8264. **Weinwurm, S.** [Relation of Flashing- and Combustion-Temperatures of Mineral Oils.] *Mitth. Chem. Inst. Techn. Unters. Wien.*, 1892.
8265. **Weis, J. A.** Die Exkursion nach Kissármás und dem oberen Iza-Tale. *Org. Ver. Bohrtechn.*, bd. xviii, pp. 263-265. [1911.]
8266. **Weiser, J.** Über die Fabrikationsprozesse, welche zur Gewinnung von Paraffin unter Verwendung von künstlicher Kälte dienen. 1910.
8267. **Weisberg, —.** [On some Inconveniences Developing in the Oil Trade.] *Russk. Pragda*, 1880, no. 32.
8268. **Weise, K. v.** Petroleumprüfung. *Monatsschr. Gew. Ver. Cöln.*, 1870, p. 319.
8269. **Weiss, E.** Die Schmierfähigkeit der Schmieröle. *Poly. Journ.*, bd. cccix, pp. 76-80. [1898.]
8270. **Weiss, F. J.** Kondensation. 8vo, Berlin, 1901.
8271. **Weiss, J. M.** The antiseptic effect of Creosote Oil and other Oils used for preserving timber. *Journ. Soc. Chem. Ind.*, vol. xxx, pp. 1348-1353. [1911.]
8272. **Weisz, T.** Der Bergbau in den Siebenbürgischen Landestheile. *Mitth. Jahrb. k. ung. Geol. Anst.*, bd. ix, pp. 107-184. [1891.]
8273. **Weithofer, A.** Die Kohlenmulde von Carpano in Istrien. *Oesterr. Zeitschr. Berg- Hüt.*, bd. xii, pp. 261-267, 275-281, pl. xii. [1893.]
8274. **Welch, G. M.** Extinguishing the flame of a 600-pound pressure million feet capacity gas well [at Caney, Illinois]. *Nat. Gas Journ.*, vol. i, no. 2, pp. 4-8. [1907.]
8275. ——— The Relationship of Engineering to the Natural Gas Industry. *Ibid.*, no. 7, pp. 13, 14. [1907.]
8276. **Welch, R.** On Dopplerite from Sloggan Bog, Co. Antrim. *Irish Nat.*, vol. xxvii, pp. 232, 233. 1908.
8277. **Weller, A.** Vorkommen alkaloidartiger Basen in Paraffinöl. *Ber. deutsch. chem. Ges.*, bd. xx, pp. 2097-2099. [1887.]
8278. **Wellsted, J. R.** Travels in Arabia. 8vo, London, 1838.
8279. ——— Travels to the City of the Caliphs, along the shores of the Persian Gulf and the Mediterranean, including a Voyage to the Coast of Arabia and a Tour on the Island of Socotra. 8vo, London, 1840.
8280. **Wenckenbach, F.** Uebersicht über die in Nassau aufgefundenen einfachen Mineralien. *Jahrb. Nassau Ver. Nat.*, bd. xxxi-xxxii, pp. 147-219. [1879.]
8281. **Wentworth, J. F.** The Efficiency of the Marine Oil Engine. *Marine Engineering*, vol. ix, pp. 594-596. 1904.
8282. **Werner, A.**, and **F. Zilkens.** Ueber eine neue Synthese von Kohlenwasserstoffen. *Ber. deutsch. chem. Ges.*, bd. xxxvi, pp. 2116-2118. [1905.]
8283. **Werner, H.** Notiz zu "Vaseline." *Arch. Pharm.*, f. 3, bd. xvi, pp. 45, 46. [1880.]
8284. **Werweke, L. v.** Vorkommen, Gewinnung und Entstehung des Erdöls in Unter-Elsass. *Zeitschr. prakt. Geol.*, bd. iii, pp. 97-114, pl. iii. [1895.]

8285. **Werke, L. v.** Weitere Beiträge zur Kenntniss des Erdölorkommens im Elsass. *Zeitschr. prakt. Geol.*, bd. iv, pp. 41-45. [1896.]
8286. ———— Erläuterungen zu Blatt Niederbronn [53]. *Geol. Specialk. Elsass-Lothr.*, 1897.
8287. ———— Zur Frage der Entstehung der elsässischen Erdkäller. *Müth. philom. Ges. Els.-Lothr.*, bd. x, pp. 416-420. [1902.]
8288. ———— Bericht über die Ausflüge des Oberrheinischen geologischen Vereins in Worth & Saar. *Ber. ober-rhein. geol. Ver.*, no. 39, pp. 38-62, pls. ii-lv. [1907.]
8289. ———— Ueber die Entstehung der elsässischen Erdöl-lager. *Müth. geol. Landesanst. Els.-Lothr.*, bd. vi, pp. 1-30. [1907.]
8290. ———— Schichtenfolge im Oligocän der Tiefbohrungen von Oberstritten und Oberkutzenhausen. *Ibid.*, pp. 31-47. [1907.]
8291. **West, —.** Report for 1886 on the Trade of Suez. *Dipl. Cons. Rep.*, ann. ser., no. 84. [1887.]
8292. **West, W. R.** Fuel Oil. *Electrician*, vol. xxx, pp. 302, 303. [1902.]
8293. **Wetherill, C. D.** On Adipocire and its Formation. *Trans. Amer. Phil. Soc.*, ser. 2, vol. xi, pp. 1-26. [1857.]
8294. **Wetherill, C. M.** On a new Variety of Asphalt (Melanasphalt). *Ibid.*, ser. 2, vol. x, pp. 353-358. [1853.]
8295. **Weudriner, —.** Die Bestimmung des Schmelzpunkts von Pech, Asphalt und ähnlichen Stoffen. *Zeitschr. angew. Chem.*, bd. xviii, pp. 622-626, 1946. [1905.]
8296. **Werber, —.** Der Ozokeritbergbau in Galizien. *Chem. Ind.*, bd. xxix, pp. 599-601. [1906.]
8297. **Weyl, E.** Le Chauffage au moyen des huiles lourdes. *Journ. Marine*, vol. xvi, p. 67. [1893.]
8298. **Weymouth, C. R.** Fuel Economy Tests at a Large Oil Burning Electric Power Plant having Steam Engine Prime Movers. *Trans. Amer. Soc. Mech. Eng.*, vol. xxx, pp. 775-796. [1908.]
8299. ———— Unnecessary Losses in Firing Fuel Oil and an Automatic System for their Elimination. *Ibid.*, pp. 797-835. [1908.]
8300. ———— Furnace arrangements for Fuel Oil. *Journ.* vol. xxxiii, pp. 879-882. [1911.]
8301. **Wheelan, F. H.** The Gas Well at Summerland. *10th Ann. Rep. State Mineral. California for 1890*, pp. 601-603. [1890.]
8302. **Wheeler, G.** Travels in Dalmatia, Greece and the Levant. 8vo, Amsterdam, 1689.
8303. **Wheeler, H. A.** Oil and Gas in the St. Louis district. *Journ. Assoc. Eng. Soc.*, vol. xlii, pp. 188-199. [1909.]
8304. ———— The New Oilfield at Carlyle, Illinois. *Eng. Min. Journ.*, vol. xcii, pp. 63, 64. [1911.]
8305. ———— The Illinois Oilfields. *Ibid.*, pp. 355, 356. [1911.]
- Wheeler, R. V.**, see **Bone, W. A.**; and **Burgess, M. J.**
8306. **Whipple, G. C.** and **D. D. Jackson.** The Action of Water on Asphalts. *Eng. News*, vol. xliii, pp. 187, 188. [1900.]
8307. **White, A. H.** The Oxidation of Nitrogen as a Source of Error in the Estimation of Hydrogen and Methane. *Journ. Amer. Chem. Soc.*, vol. xxiii, pp. 476-482. [1901.]
8308. **White, C. B.** Report on the Quality of Oils derived from Petroleum, sold for illuminating purposes in this city (New Orleans), made to the General Assembly of Louisiana, 31st Dec. 1869. *New Orleans*, 1870.
8309. **White, G.** Viscosity, Lubrication and Cost. *Petrol. World*, vol. viii, pp. 499-503. [1911.]
8310. **White, H.** Geology, Oil Fields and Minerals of Canada West: how and where to find them. With a new theory for the production and probable future supply of Petroleum. 8vo, Toronto, 1865.
8311. **White, H. T.** Report on the Oil Wells of Burma. (Blue Book), fo. 1888.
8312. **White, I. C.** Report of Progress in the Beaver River District of the Bituminous Coal-fields of Western Pennsylvania. *2nd Geol. Surv. Penns. Q.* 8vo, Harrisburg, 1878.
8313. ———— The Geology of Lawrence County, and a Special Report on the Condition of the Coal Measures in Western Pennsylvania and Eastern Ohio. *Ibid.*, QQ. 8vo, Harrisburg, 1879.
8314. ———— The Geology of Mercer County. *Ibid.*, QQQ. 8vo, Harrisburg, 1880.
8315. ———— The Geology of Erie and Crawford Counties. *Ibid.*, Q 4. 8vo, Harrisburg, 1881.
8316. ———— Report of the Morgantown, W. Va., gas well. *The Virginias*, vol. vi, pp. 91, 92, 101. [1885.]
8317. ———— The Geology of Natural Gas. *Science*, vol. v, pp. 521, 522; vol. vi, p. 43. [1885.]
8318. ———— The criticisms of the Anticlinal Theory of Natural Gas. *Petroleum Age*, vol. v, pp. 1263-1267, 1464, 1465. [1886.]
8319. ———— Oil and Gas Resources of West Virginia. *Amer. Geol.*, vol. vii, pp. 302-305. [1892.]
8320. ———— The Mannington Oil-Field and the History of its Development. *Bull. Geol. Soc. Amer.*, vol. iii, pp. 187-216, pl. vi. [1892.]
8321. ———— Origin of Grahmitite. *Ibid.*, vol. x, pp. 277-284, pl. xxix, map. [1899.]
8322. ———— Petroleum and Natural Gas. *Geol. Surv. W. Va.*, vol. i, pp. 123-378. [1899.]
8323. ———— Geology of West Virginia. *Mines and Minerals*, vol. xxii, pp. 153-155. [1901.]
8324. ———— The Waste of our Fuel-Resources (Conference on Conservation of Natural Resources, May 13, 1908). 8vo, Morgantown, 1908.
8325. ———— Relatório final do Comissão de Estudos das Minas de Carvão de Pedra do Brazil. 4to, Rio de Janeiro, 1908.
8326. ———— Petroleum and Natural Gas in West Virginia. *Nat. Gas. Journ.*, vol. v, no. 9, pp. 19-22. [1911.]
- White, I. C.**, see **Munn, M. J.**
8327. **White, M.** Distillation du pétrole. *Technol.*, t. xviii, p. 569. [1857.]
8328. **White, T. H.** Petrol Motors and Motor Cars: A Handbook for Engineers, Designers and Draughtsmen. 8vo, London, 1904.
8329. **White, W.** Presidential Address. *Proc. Inst. Civ. Eng.*, vol. clv, pp. 2-169. [1904.]
8330. **White, Z. L.** Natural Gas at Findlay. *Amer. Mag.*, Dec. 1887.
8331. **Whitehouse, S.** Asphalt Industry, Venezuela. Conditions at the Re-opened Beds near Guanoco. *U.S. Cons. Rep.*, no. 357, pp. 191, 192. [1910.]
8332. **Whitlark, W. J.** Examination of twenty-four specimens of Kerosene sold in Michigan in April and May 1876. *Amer. Chem.*, vol. vii, p. 47. [1876.]
8333. **Whitmore, W. H.** Results of Destructive Distillation of Bituminous Substances. Boston, 1860.
8334. **Whitney, J. D.** Geological Survey of California, vol. i. 4to, Philadelphia, 1865.
8335. ———— On the Fresh Water Infusorial Deposits of the Pacific Coast, and their Connection with the Volcanic Rocks. *Proc. Ac. Sci. Calif.*, vol. iii, pp. 319-324. [1868.]
8336. **Whittlesey, C.** Origin of Bitumen of Stratified Rocks. *Cleveland Ann. Sci.*, vol. i, pp. 153-157. [1853.]
- Wichelhaus, H.**, see **Salzmann, M.**
8337. **Wichmann, A.** Bericht über eine im Jahre 1888-89. . . ausgeführte Reise nach dem Indischen Archipel. *Tijdschr. k. Ned. Aardr. Gen.*, r. 2, dl. ix, pp. 314, 16 pls. [1890-1892.]
8338. ———— Petrographie van Nederlandsch Indie. Verhandeling no. 1. Gesteine von Timor, nach Sammlungen von Macklot, Beinwadt und Schneider. *Jaarb. Mijne. Ned. O.-Ind.*, jg. xi, Wet. pp. 181-252, map and pl.; jg. xii, Wet. pp. 231-284, pl. iii; jg. xvi, Wet. pp. 46-128, pls. iv, v. [1882-1887.]



8339. **Wickersham, S. M.** To extinguish Oil Fires. *Proc. Eng. Soc. West Penns.*, vol. ix, pp. 279-281. [1893.]
8340. **Wickersheimer, E.** Considérations économiques sur l'Exploitation du pétrole en Roumaine. 8vo, Paris, 1907.
8341. **Widmann, H.** Rohölmotor von Lietzenmayer. *Bayer. Ind. Gewerb.*, bd. xii, pp. 106-108. [1909.]
8342. **Wiebe, H. F., and P. Hebe.** Vergleichende Prüfung englischer und deutscher Petroleumprober. *Petroleum Zeitschr.*, bd. v, pp. 885-889. [1910.]
8343. **Wiederhold, E.** Zur Technologie des amerikanischen Erdöls. *N. Gewerbe-Bl. Kurh.*, 1862, no. 5; 1863, no. 7.
8344. — Einfaches Verfahren, um durch einmalige Destillation aus dem rohen Amerikanischen Petroleum farblose und geruchlose (d. h. nicht unangenehmriechende) Producte zu erhalten. *Ibid.*, 1864, no. 20.
8345. — Ueber die Löslichkeit der Harzöle und Mineralöle und der Mischung beider in Aceton. *Journ. prakt. Chem.*, bd. clv, pp. 394-397. [1893.]
8346. **Wiegand, E.** Neuerungen an Apparaten für Erdöldestillation. *Polyt. Journ.*, bd. cxclv, pp. 227-229. [1887.]
- Wiegand, E., see Beilstein, F.**
8347. **Wieland, C. F.** Comparative Evaporative Values of Coal and Oil. *Journ. Amer. Soc. Mech. Eng.*, vol. xxxiii, pp. 872-876. [1911.]
8348. **Wielezinski, M.** Zur Frage der Bestimmung von Verunreinigungen im Boryslawer Rohöl. *Naphta*, bd. xii, pp. 23-25; bd. xiii, p. 10. [1904, 1905.]
8349. — Das Rohöl von Boryslaw. *Ibid.*, bd. xii, pp. 227-230, 247-250. [1904.]
8350. — Ueber die Messungen von Rohöl in Reservoiren. *Ibid.*, pp. 233, 234. [1904.]
8351. — Die Verwendung des Erdgases. *Ibid.*, pp. 264, 265. [1904.]
8352. — Das Boryslawer Röhrenwachs. *Ibid.*, bd. xiii, p. 364. [1905.]
8353. — Boryslaw and its Surroundings. *Petrol. Rev.*, vol. xii, pp. 227, 228. [1905.]
8354. — [The Oilfields of Tarnawa, Wielopole, and Zagorz in Galicia.] *Monit. Int. Petr. Roum.*, t. vi, p. 768, 769. [1906.]
8355. — Ueber das Boryslawer Rohöl. *Chem.-Zeit.*, bd. xxx, pp. 106-109. [1906.]
8356. — Destillationsversuche mit Boryslawer Masut. *Ibid.*, bd. xxxi, p. 499. [1907.]
8357. — Die Heizölfrage in Boryslaw. *Petroleum Zeitschr.*, bd. ii, pp. 485-487. [1907.]
8358. — Zur Reinigung der Abwasser aus Petroleumraffinerien. *Ibid.*, bd. v, pp. 1237-1240. [1910.]
8359. **Wielezinski, M., and J. Gruszkiewicz.** Das Rohöl des dritten Horizonts in Boryslaw. *Naphta*, bd. xv, pp. 248, 249. [1907.]
- Wielezinski, M., see Gruszkiewicz, J.**
8360. **Wigand, —.** Die Explosion auf dem Kalkwerk der Gewerkschaft Desdemona im Lemethal Bergrevier, Hannover. *Zeitschr. Berg-Hütt.-Säinew.*, bd. liv, pp. 461-473, pl. [1906.]
8361. **Wiinen, E.** De eilanden Rottien en Savoe en daarop voorkomende zoutwaterbronnen. *Nat. Tijdschr. Ned. Ind.*, dl. xxvii, pp. 448-451. [1864.]
8362. **Wilbur, F. I.** The Origin and Distribution of Petroleum. *Mining World*, vol. xxxiii, pp. 1039, 1040. [1910.]
8363. **Wilcox, R.** Memoir of a Survey of Assam and the neighbouring countries, executed in 1825-8. *Edinb. Journ. Sci.*, vol. vii, pp. 63-68. [1827.]
8364. **Wild, A.** Das russische Preisausschreiben betreffend eine Petroleumlampe. *Sitz. Ver. Beförd. Gewerbfl. Preuss.*, 1881, p. 112.
8365. **Wilda, H.** Die Ansichten der amerikanischen Petroleum-Industrie. *Naphta*, bd. xiv, pp. 349-352. [1906.]
8366. **Wilde, P. de.** Sur l'origine du pétrole et de ses dérivés. *Arch. Sci. Phys. Nat.*, sér. 4, t. xxiii, pp. 558-580. [1907.]
8367. **Wildman, R.** American, Russian and Sumatra Petroleum. *Rep. Cons. U.S.*, vol. xi, pp. 456-459. [1892.]
8368. **Wilke, —.** Petrolia, or the Oil Regions of the United States. Chicago, 1865.
8369. **Wilkins, H.** Rock Oil. *Journ. Soc. Arts*, vol. ix, p. 179. [1861.]
8370. — Oil Springs. *Ibid.*, p. 711. [1861.]
8371. **Wilkinson, C. S., I. I. Baylis, and H. Wilkinson.** Geological Map of the Districts of Hartley, Bowenfels, Wallerawang, and Rydal. Scale 1:31,680. [1877?]
- Wilkinson, H., see Wilkinson, C. S.**
8372. **Wilkinson, J. H.** An Enquiry into the Natural History, Chemical Properties, and Medical Virtues of the Rock Oil or Green Mineral Naphtha of Barbadoes, with particulars of its remedial powers in cutaneous eruptions, glandular complaints, and diseases of the joints. 8vo, London, 1850.
8373. **Willard, —.** Ore roasting with Petroleum Fuel. *Min. Sci. Press*, vol. xxii, nos. 10 and 16. [1871.]
8374. **Willey, D. A.** The Oil Fields of the West. *Sci. Amer.*, n.s., vol. xcii, pp. 484, 485. [1905.]
8375. — The latest American Petroleum Discoveries [Beaumont, Texas]. *Cassier's Mag.*, vol. xxviii, pp. 370-380. [1905.]
8376. **Williams, A.** Asphalt. *Min. Res. United States* for 1882, p. 605; for 1883 and 1884, pp. 937-948.
8377. **Williams, C. G.** On a method of distinguishing the Volatile Oils of the series  $C_2H_4$ . *Phil. Mag.*, ser. 4, vol. v, pp. 536, 537. [1853.]
8378. — On a Process for ascertaining the Equivalents of some Fluid Hydrocarbons by means of Bromine. *Chem. Gaz.* 1853.
8379. — On the Action of Bromine on the Oils of the Series  $C_2H_4$ . *Chemist*, vol. i, pp. 72-75. [1854.]
8380. — On the Volatile Bases produced by Destructive Distillation of the Bituminous Shale of Dorsetshire. *Journ. Chem. Soc.*, vol. vii, pp. 97-107. [1854.]
8381. — On the presence of Pyridine in Naphtha among the Volatile Bases in the Naphtha from the Bituminous Shale of Dorsetshire. . . . *Phil. Mag.*, ser. 4, vol. viii, pp. 209-212. [1854.]
8382. — On some of the Basic Constituents of Coal Naphtha. *Edin. N. Phil. Journ.*, vol. ii, pp. 324-331. [1855.]
8383. — On some of the Products of the Destructive Distillation of Boghead Coal. *Phil. Trans.*, 1857, pp. 447-462, 737-745.
8384. — On the Hydrocarbons produced by Destructive Distillation of Boghead Coal. *Journ. Chem. Soc.*, vol. xv, pp. 130-134. [1862.]
8385. — On the Formation of the Iodides of the Alcohol Radicles from Boghead Naphtha. *Ibid.*, vol. xv, pp. 359-363. [1862.]
8386. — On Bathvillite, a new inflammable mineral. *Chem. News*, vol. vii, pp. 133-135. [1863.]
8387. — Nouvelles recherches sur les hydrocarbures contenus dans les parties les plus volatiles de l'huile de houille. *Compt. Rend.*, t. lxii, pp. 390-392. [1866.]
8388. **Williams, C. W.** Fuel; its combustion and economy. 12mo, London, 1879.
8389. **Williams, F. H.** Synthesis of Hydrocarbons by the Treatment of Cast Iron with Acids. *Amer. Journ.*, ser. 3, vol. vi, pp. 363-368. [1873.]
8390. **Williams, G.** Liquid Hydrocarbons from Compressed Petroleum Gas. *Chem. News*, vol. xlix, p. 197. [1884.]
8391. **Williams, H.** Eruption of a Submarine Volcano, seen from Kyouk Phyu. *Journ. As. Soc. Beng.*, vol. xiv, p. xxiv. [1845.]
8392. **Williams, H. S.** On the Classification of the Upper Devonian. *Proc. Amer. Assoc.*, vol. xxxiv, pp. 222-234. [1886.]
- Williams, J. J., see Barnard, J. G.**

8393. **Williams, S. G.** Notes on the Geology of some Localities near Cañon City, Fremont County, Colorado. *Bull. U.S. Geol. Surv. Territories*, ser. 2, no. 5, pp. 249-251. [1876.]
- Williamson, J.**, see **Silliman, B.**, jun.
8394. **Willigk, E.** Vorläufige Notiz über Oxydationsprodukte des Paraffins. *Ber. deutsch. chem. Ges.*, bd. iii, pp. 138-140. [1870.]
8395. **Willis, B.** Oil of the Northern Rocky Mountains. *Eng. Min. Journ.*, vol. lxxii, pp. 782-784. [1901.]
8396. **Williston, A. L.** Liquid Fuel for Power Purposes. *Eng. Mag.*, vol. xxv, pp. 237-252, 562-573, 721-730. [1903.]
8397. **Willits, A. B.** United States Government Tests of Lubricant Oils. *Iron Age*, vol. lxxvii, p. 332. [1906.]
8398. **Wilson, A.** Production and Use of Water Gas. *Proc. Cleveland Inst. Eng.*, 1885-1887, p. 169-200.
8399. **Wilson, E.** On the Durham Salt-deposit. *Quart. Journ. Geol. Soc.*, vol. xiv, pp. 761-782. [1888.]
8400. **Wilson, G. G.** Report for 1890, 1892, 1895 on the Trade of Callao, Peru. *Dipl. Cons. Rep.*, ann. ser., nos. 916, 1185, 1714. [1891, 1893, 1896.]
8401. **Wilson, H. C.** Liquid Fuel and Methods of Burning it. *Trans. Inst. Marine Eng.*, vol. viii, no. 60. Pp. 48. [1896.]
8402. **Wilson, H. W.** Reports for the years 1907-1910 on the Trade of the Consular District of Tampico. *Dipl. Cons. Rep.*, ann. ser., nos. 4051, 4215, 4663. [1908, 1909, 1911.]
- Wilson, J. S. G.**, see **Cadell, H. M.**
8403. **Wilton, C. P. N.** Account of the Burning Mountain in Australasia, called Mount Wingen, near Hunter's River. *Edinb. Journ. Sci.*, ser. 2, vol. ii, pp. 270-273. [1830.]
8404. ——— Notice of the Burning Mountain of Australia. *N.S. Wales Mag.*, vol. i, pp. 45, 46. [1833.]
8405. **Wimmel, Th.** Ueber den Schmelzpunkt der Fette und ihr Verhalten beim Erstarren. *Zeitschr. anal. Chem.*, bd. vii, pp. 267-269. [1868.]
8406. **Wimperis, H. E.** The Internal Combustion Engine. 8vo, London, 1908.
8407. **Wimpheling, —.** [Bechelbronn Oil-springs.] 1498.
8408. **Winans, C. S.** [New Oil Fields.] Spain. Development now Progressing—Various successful Borings. *U.S. Cons. Rep.*, no. 355, pp. 138, 139. [1910.]
8409. **Winchell, A.** The Oil Region of Michigan. Description of the Baker Tract, situated in the heart of the Oil Region of Michigan. *Detroit*, 1864.
8410. ——— Geological Report on certain Oil Lands lying in the Counties of Sanilac and St. Clair, Mich., comprising in all about 31,000 acres. 8vo, *Detroit*, 1865.
8411. ——— Report on the Oil Lands of Lambton County, Canada West. 8vo, *Detroit*, 1866.
8412. ——— Report on the Bruce Oil Sands at Oil Springs, Canada West. *Detroit*, 1866.
8413. ——— Geological Report on the Lands of the Neff Petroleum Company, lying in Knox and Coshocton Counties, Ohio. 8vo, *Detroit*, 1866.
8414. ——— Report on certain Oil Lands in Wetzel County, West Virginia. 12mo, *Detroit*, 1866.
8415. ——— Note on the Geology of Petroleum in Canada West. *Amer. Journ.*, ser. 2, vol. xli, pp. 176-178. [1866.]
8416. ——— Petroleum in Tennessee. *Mining and Manuf. Journ. (Pittsburg)*, Jan. 2, 1867.
8417. ——— Sketches of Creation: A Popular View of some of the Grand Conclusions of the Sciences in reference to the History of Matter and of Life. . . . 12mo, New York, 1870.
8418. ——— Geological Studies; or Elements of Geology. 8vo, Chicago, 1886.
8419. **Winchell, N. H.** Natural Gas in Minnesota. *Bull. Geol. Surv. Minnesota*, no. 5, pp. 39. [1889.]
8420. **Winda, V. I.** [Petroleum in the Kuban Province.] *Trudi St. Peterb. Obsch. Estestv.*, 1904, v. 4.
8421. ——— The Development of the Maikop Oil Fields. *Petrol. Rev.*, vol. xxiii, pp. 259-261. [1910.]
8422. **Windaus, A.** Ueber Cholesterin. *Ber. deutsch. chem. Ges.*, bd. xxxv, pp. 2027-2032. [1904.]
8423. **Windakiewicz, E.** [Borings for Oil at Orow on the Stry.] *Sprawozd. Kom. Fiz. Gal.*, t. vi, pp. (82)-(87). [1871.]
8424. ——— Ein Beitrag zur Petroleumgewinnung in Galizien. *Oesterr. Zeitschr. Berg-Hütt.*, bd. xxii, p. 350. [1874.]
8425. ——— Ueber die Wichtigkeit des Vorkommens von bituminösem Schiefer in Galizien. *Ibid.*, bd. xxiii, p. 196. [1875.]
8426. ——— Das Erdöl und Erdwachs in Galizien. *Berg-Hütt. Jahrb.*, bd. xxiii, pp. 1-133. [1875.]
8427. ——— Ueber die Nothwendigkeit von Tiefbohrungen in Galizien. *Oesterr. Zeitschr. Berg-Hütt.*, bd. xxiv, pp. 123-125. [1876.]
8428. ——— Resultate mit dem canadischen Bohren. *Ibid.*, bd. xxvii, pp. 650-652. [1884.]
8429. **Winkel, H.** Naphtal als Brennstoff für Dampfkesselheizung. *Polyt. Journ.*, bd. cccxvi, pp. 782-786. [1901.]
8430. ——— Am Oel vorbeigehen. *Naphta*, bd. xii, pp. 6, 7. [1903.]
8431. ——— Ein naphtagelogeisches Bilderbogen. *Ibid.*, pp. 19-21, pl. [1903.]
8432. ——— Tiefengeologie und Bohrchroniken. *Org. Ver. Bohrtechn.*, bd. xvii, pp. 145-148. [1910.]
8433. **Winklehner, H.** Schürflungen in Persien. *Oesterr. Zeitschr. Berg-Hütt.*, bd. xlvi, pp. 629-633, 645-649. [1899.]
8434. **Winkelbech, K.** Ein Beitrag zur Chemie der Kolloide. *Zeitschr. angew. Chem.*, bd. xix, pp. 1953-1955. [1906.]
8435. **Winter, E.** Kesselfeuerungen für flüssige Brennstoffe. *Allgem. österr. Chem. Techn.-Zeit.*, bd. xxvi, pp. 57-61. [1903.]
8436. **Winterfeld, G.**, and **W. Mecklenburg.** Über den Nachweis von Mineralöl in ausländischen Wollfettölen. *Mitt. techn. Mat.-prüf.-amt.*, bd. xxviii, pp. 471-474. [1910.]
8437. **Winterl, —.** Zerlegung eines schwarzen zähen Bergöls, aus Ungarn, zwischen Pekenicza und Moslowina. *Chem. Ann.*, 1788, bd. i, pp. 493-499.
8438. **Wischin, R. A.** Theorie und Praxis der chemischen Reinigung von Mineralölen. *Chem. Rev. Fett-Harz-Ind.*, bd. i, no. 26, pp. 1-4; no. 27, pp. 2, 3. [1895.]
8439. ——— Zur Feststellung einheitlicher Untersuchungs-Methoden in der Petroleum-Industrie. *Ibid.*, no. 27, pp. 3-5. [1895.]
8440. ——— **Vademecum des Mineralöl-Chemikers.** *Brunswick*, 1896.
8441. ——— Zur Schaffung einheitlicher Untersuchungs-Methoden in der Mineralölindustrie. *Chem. Rev. Fett-Harz-Ind.*, bd. iv, pp. 75-78, 89-91. [1897.]
8442. ——— Der Ragosin'sche Apparat zur Destillation von Erdöl und Erdrückständen. *Ibid.*, bd. vi, pp. 1-5. [1890.]
8443. ——— Die cyclischen Polymethylene des Erdöls. *Chem.-Zeit.*, bd. xxiii, pp. 916-926; bd. xxviii, pp. 814-818; bd. xxix, pp. 1126, 1127. [1899, 1904, 1905.]
8444. ——— Ueber das Lamansky-Nobelsche Viscosimeter. *Chem. Rev. Fett-Harz-Ind.*, bd. vii, pp. 73-75. [1900.]
8445. ——— Die russische Erdölindustrie am Anfang unseres Jahrhunderts. *Zeitschr. angew. Chem.*, bd. xiii, pp. 313-318. [1900.]
8446. ——— Verwerthung der Abfallproducte in der Mineralölindustrie. *Ibid.*, pp. 507-511. [1900.]
8447. ——— Die Naphtene (cyclische Polymethylene des Erdöls) und ihre Stellung zur anderen hydrirten cyclischen Kohlenwasserstoffen. *Brunswick*, 1901.
8448. ——— Der Kampf des deutschen Grosskapitals gegen das Petroleum-Monopol der Standard Oil Company. *Zeitschr. angew. Chem.*, bd. xvii, pp. 1887-1891. [1904.]
8449. ——— Die Zukunft des Petroleum als Ausgangsmaterial chemischer Industrien. *Petroleum Zeitschr.* bd. iii, pp. 1062-1069. [1908.]

8450. **Wischin, R. A.** Ueber Regeneration der Abfallprodukte. *Compt. Rend. Congr. internat. Pétrole*, sess. 3, t. II, pp. 621-626. [1910.]
8451. ——— Spezifische Eigenschaften der rumänischen Rohöle und die dadurch bedingten Methoden ihrer Verarbeitung. *Ibid.*, pp. 627-636. [1910.]
8452. ——— Die Zukunft des Petroleums als Rohmaterial chemischer Industrien. *Ibid.*, pp. 637-644. [1910.]
8453. **Wiselun, J. A. B.** Minerale en petroleumhoudende bronnen te Tjitra en Langtoeng. *Nat. Tijdschr. Ned. Ind.*, bd. xxxiii, pp. 404-407. [1873.]
8454. **Wispek, P.** Austrian Government Oil Refinery. *Petrol. World*, vol. viii, pp. 46-49, 76-80. [1911.]
8455. ——— Oil Fuel on a State Railway. *Ibid.*, pp. 133-136. [1911.]
8456. ——— Die Regenerierung der Abfallschwefelsäure der Petroleumraffinerien. *Petroleum Zeitschr.*, bd. vi, pp. 1045-1048. [1911.]
8457. ——— Die staatlichen Erdreservoirs für Rohöl bei Boryslaw. *Ibid.*, pp. 2021-2024. [1911.]
8458. **Witham, H.** Notice regarding a Vein of Asphaltum, or sluggy Mineral Pitch, found imbedded in Gneiss, in the hill of Castle Lead near Dingwall, in Ross-shire. *Mem. Wern. Soc.*, Feb. 5, 1825.
8459. **Witter, F. M.** Gas Wells near Letts, Iowa. *Amer. Geol.*, vol. ix, pp. 319-321. [1892.]
8460. **Witti, F.** Diary kept during an Excursion to the Oil-Shales of the Sekuati river, and the subsequent journey overland from Marudu Bay to Papar, Singapore, 1855.
8461. **Wittich, L. L.** Petroleum in Oklahoma. *Mines and Minerals*, vol. xxxii, pp. 291-294. [1911.]
8462. ——— History of Kansas Oil Development. *Ibid.*, p. 384. [1912.]
8463. **Witz, A.** Traité théorique et pratique des moteurs à gaz et à pétrole. 8vo, Paris, 1903.
8464. **Woas, F.** Der Asphalt, seine Geschichte, Gewinnung und Verwendung. 8vo, Berlin, 1880.
8465. **Woeikov, A.** Kaukasische Excursionen im Jahre 1888. *Mitth. Ver. Erbk. Halle*, 1890, pp. 31-57.
8466. **Wolf, T.** Geognostische Mittheilungen aus Ecuador. *N. Jahrb.*, 1874, pp. 377-398.
8467. ——— Geografía y geología del Ecuador. 8vo, Leipzig, 1892.
8468. **Wolf, G.** Die Verarbeitung des Ozokerits auf Ceresin. *Prometheus*, bd. xix, pp. 261-264. [1908.]
8469. **Wolf, K.** Der Asphalt. *Warenkunde*, bd. i, p. 91. [1906.]
8470. **Wolf, M. E.** [The Oil-burning Systems of Rumania.] *Monit. Int. Pétrol. Roum.*, t. ix. [1908.]
8471. **Wolfram, H.** Die Entwicklung der Gasreinigung. *Zeitschr. angew. Chem.*, bd. xxiii, pp. 1516, 1517. [1910.]
8472. **Wolny, R.** Ueber analytische Operationen und Apparate. *Zeitschr. anal. Chem.*, bd. xxiv, pp. 47-56, 202-216. [1885.]
8473. **Wolski, W.** Ueber die Bohrstange. *Glückauf*, bd. xxxvii, pp. 213-216. [1901.]
8474. ——— Le Système de Sondage hydrodynamique. *Compt. Rend. Congr. internat. Pétrole*, sess. 3, t. II, pp. 439-444. [1910.]
8475. **Wood, —.** Report on the Trade of the Monthon of Puket [Malay Peninsula, Siam], for the year 1909 and part of 1910. *Dipl. Cons. Rep.*, ann. ser., no. 4622. [1911.]
8476. **Wood, A. H.** Artificial Light and Heat, and New Inventions relating thereto. *Journ. Gaslight.*, vol. xxii, pp. 144, 145. [1873.]
8477. **Wood, C. G.** Report for 1894, 1895 on the Trade of Tabreez. *Dipl. Cons. Rep.*, ann. ser., no. 1569. [1895.]
8478. **Wood, E. B.**, see **Fisher, W. E.**, and **Morgan, W.**
8478. **Wood, H.** Reports of the Under Secretary for Mines, etc. *Ann. Rep. Dept. Mines, New South Wales*, 1876-1894.
8479. **Wood, H. G.** Commerce and Industries of Dutch India. *Rep. Cons. U.S.*, vol. xxxi, pp. 157-165. [1889.]
8480. **Wood, H. L.** Oil Fields of Mexico. *Oil and Gas Journ.*, vol. ix, nos. 43-45. [1911.]
8481. **Wood, J.** A Personal Narrative of a Journey to the sources of the River Oxus by the route of the Indus, Kabul and Badakshan . . . 1836, 1837, and 1838. 8vo, London, 1841.
8481. **Wood, L.**, see **Brown, H. C.**
8482. **Woodbury, C. J. H.** On the relative Efficiency of Kerosene Burners. *Journ. Franklin Inst.*, vol. xcvi, pp. 115-117. [1873.]
8483. ——— Measurements of the Friction of Lubricating Oils. *Trans. Amer. Soc. Mech. Eng.*, vol. i, pp. 73-118; vol. vi, pp. 136-167. [1880, 1885.]
8484. **Woodhouse, A.** Discovery of Naphtha in Oukhta District. *Board of Tr. Journ.*, vol. lxiii, pp. 471, 472. [1908.]
8485. **Woodruff, E. G.** The Oil Region around Cleveland, Pawnee County, Oklahoma. *Science*, n.s., vol. xxiii, p. 621. [1906.]
8486. ——— The Lander Oil Field, Fremont County (Wyoming). *Bull. U.S. Geol. Surv.*, no. 452, pp. 1-36, pls. i-vi. [1911.]
8487. **Woodward, A. S.** On a New Labyrinthodon from Oil-Shale at Airly. *Rec. Geol. Surv. N.S. Wales*, vol. viii, pp. 317-319, pl. II. [1909.]
8488. **Woodward, H. A.** Notes on the finding of Natural Grease in the Cannel Mine at Newtown Collieries of the Clifton and Kersley Coal Company, Limited. *Trans. Manch. Geol. Soc.*, vol. xxi, pp. 175-180. [1891.]
8489. **Woodward, H. B.** Notes on the Occurrence of Natural Gas at Heathfield, Sussex. *Summ. Progr. Geol. Surv. U. K.*, 1902, pp. 195-199.
8490. **Woodward, H. P.** Western Australia. Annual General Report for 1888-1889. 8vo, Perth, 1890.
8490. **Woodward, S. M.**, see **Lucke, C. E.**
8491. **Woodworth, R. B.** The Steel Oil Derrick. [U.S. Fields and Wells.] *Proc. Eng. Soc. W. Penns.*, vol. xxv, pp. 245-312. [1909.]
8492. **Woadley, L. H.** Economic Geology of the Beaver Quadrangle, Pennsylvania (southern Beaver and northwestern Allegheny counties [Pa.]). *Bull. U.S. Geol. Surv.*, no. 286. Pp. vi, 132; 8 pls. [1906.]
8493. ——— Beaver, Pa. Fo. 134, *U.S. Geol. Surv.*, 1906.
8493. **Wootton, H. A.**, see **Jones, H. O.**
8494. **Worcester, D. C.** The Philippine Islands and their People. 8vo, New York, 1898.
8495. **Worrall, G. W.**, and **J. E. Southcombe.** The effect of superheated steam on hydrocarbon cylinder oils. *Journ. Soc. Chem. Ind.*, vol. xvii, pp. 308-311. [1908.]
8496. **Worrall, N.** Report for the year 1909 on the Trade of the Consular District of Bushire (Persia). *Dipl. Cons. Rep.*, ann. ser., no. 4606. [1910.]
8497. **Worstall, R. A.** Direct Nitration of the Paraffins. *Amer. Chem. Journ.*, vol. xx, pp. 202-217; vol. xxi, pp. 210-218. [1898, 1899.]
8498. ——— Sulphonation of the Paraffins. *Ibid.*, vol. xx, pp. 664-675. [1898.]
8499. ——— Higher Primary Nitroparaffins. *Ibid.*, vol. xxi, pp. 218-238. [1899.]
8500. ——— The Absorption of Methane and Ethane by Fuming Sulphuric Acid. *Journ. Amer. Chem. Soc.*, vol. xxi, pp. 245-250. [1899.]
8501. **Worstall, R. A.**, and **A. W. Burwell.** Decomposition of Heptane and Octane at High Temperatures. *Amer. Chem. Journ.*, vol. xix, pp. 815-845. [1897.]
8502. **Worthen, A. H.** Drift Deposits of Illinois. *Economical Geology of Illinois. Geol. Surv. Illinois*, vol. viii, pp. 1-67. [1890.]
8503. **Woskresensky, A.** Untersuchungen einiger sudrussischer Brennmaterialien des Mineralreichs. *Verh. k. russ. min. Ges.*, 1842, pp. 44-54. [1845.]
8504. **Woy, R.** Ueber Beschädigungen von Asphaltpflaster durch Leuchtgas. *Zeitschr. angew. Chem.*, bd. xvii, p. 287. [1904.]

8505. **Wreden, F.** Ueber die Constitution des Naphthalin. *Ber. deutsch. chem. Ges.*, bd. ix, pp. 590-592. [1876.]
8506. — Ueber die Hydrogenisation des Benzols und seiner Homologen. *Ann. Chem. Pharm.*, bd. cxxxvii, pp. 153-167. [1877.]
8507. **Wright & Butler, Ltd.** Petroleum (illustrated). Valuable Hints to those who use it, being a Series of Articles on the Subject, by well-known scientific and practical authorities. 8vo, Birmingham, 1887.
8508. **Wright, C. E.** Report of the State Geologist (of Michigan), 1885-1888, with List of Gas and Salt Wells. *Rep. State Board Geol. Surv. Michigan for 1891-92*, pp. 35-37, 189, 190. [1893.]
8509. **Wright, C. E., and L. C. Hubbard.** The Geology of Lower Michigan, with Reference to Deep Borings. *Geol. Surv. Michigan*, vol. v, pt. 2. Pp. xxiv, 100; 73 pls. and map. 8vo, New York, 1895.
8510. **Wright, C. R. A.** Oils, Fats, Butters, and Waxes: their Preparation and Properties, and the Manufacture therefrom of Candles, Soaps and other Products. London, 1893.
8511. **Wright, J.** The Evolution of the Petrol Carbureter. *Cassier's Mag.*, vol. xxxiii, pp. 429-437. [1908.]
8512. **Wright, W.** The Oil Regions of Pennsylvania. Showing where Petroleum is found, how it is obtained, and at what cost. With hints for whom it may concern. 12mo, New York, 1865.
8513. **Wrigley, Henry E.** Special Report on the Petroleum of Pennsylvania, its Production, Transportation, Manufacture, and Statistics. *2nd Geol. Survey of Pennsylvania, J.* 8vo, Harrisburg, 1875.
8514. — On the Present and Prospective Conditions of the Petroleum Fields of Pennsylvania. *Eng. Min. Journ.*, vol. xxviii, pp. 70, 71, 164, 165, 186, 187. [1879.]
8515. — The Amount of Oil Remaining in Pennsylvania and New York. *Trans. Amer. Inst. Min. Eng.*, vol. x, pp. 354-360. [1882.]
8516. **Wüllner, F. H. A. A.** Lehrbuch der Experimentalphysik. 2 Bde. Leipzig, 1863.
- Würth, K., see Schultz, G.**
8517. **Wurtz, C. A.** Nouveau mode de formation de quelques hydrogènes carbonés. *Compt. Rend.*, t. liv, pp. 387-390. [1862.]
8518. **Wurtz, H.** Report on a Mineral Formation in West Virginia (Grahamite). New York, 1865.
8519. — On the Grahamite of West Virginia and the New Colorado Resinoid. *Proc. Amer. Assoc.*, vol. xviii, pp. 124-135. [1869.]
8520. — Examination of a New and Extraordinary Gas-Well in the State of New York. *Amer. Journ.*, ser. 2, vol. xlix, pp. 336-339. [1870.]
8521. — American Gas-Well or Fountains. *Amer. Artisan*, n.s., vol. xiii, pp. 346, 347. [1871.]
8522. — On the great Gas-well at West Bloomfield, New York. *Proc. N. York Lyc. Nat. Hist.*, vol. i, pp. 260-265. [1873.]
8523. — The Bames System of Furnace Working with Petroleum. *Amer. Chem.*, vol. vi, pp. 94-102. [1876.]
8524. — Ozokerite of S. Utah. *Eng. Min. Journ.*, vol. xxvii, p. 108. [1879.]
8525. **Wurzer, F.** Physikalisch-chemisch Beschreibung der Schwefelquellen zu Nenndorf Cassel. 1815.
8526. **Wyndham, H.** Report for 1895 on the Trade of Roumania. *Dipl. Cons. Rep.*, ann. ser., no. 1773. [1896.]
8527. **Wynne, A. B.** Note on the Petroleum Locality of Sudkal, near Futtijung, west of Rawul Pindi, Punjab. *Rec. Geol. Surv. Ind.*, vol. iii, pp. 73, 74. [1870.]
8528. — On the Geology of the Salt Range in the Punjab. *Mem. Geol. Surv. Ind.*, vol. xiv. Pp. xvi, 313; map (2 sheets) and 31 plates. [1878.]
8529. — A Geological Reconnaissance from the Indus at Kushalgarh to the Kurram at Thal on the Afghan Frontier. *Rec. Geol. Surv. Ind.*, vol. xii, pp. 100-114, map. [1879.]
8530. **Wynne, A. B.** On the Trans-Indus Extension of the Punjab Salt Range. *Mem. Geol. Surv. Ind.*, vol. xvii, pp. 211-308, 3 maps. [1880.]
8531. **Wynne, E. W.** Procédé de purification des bulles de pétrole. *Journ. Pét.*, t. ix, p. 41. [1909.]
- Yagubov, —, see Predit, A. T.**
8532. **Yalovetski, B.** [Water, Fuel and Steam-Boilers Liquid and Gas Fuel, Crude Coal-Tar and Petroleum.] *Journ. Minist. Put. Soobsch.*, 1879, t. 1, pp. 341-352.
8533. **Yarrow, A. F.** On the possible advantage of using highly volatile liquids in lieu of water for the purposes of propulsion. *Trans. Inst. Naval Archit.*, vol. xxix, pp. 248-256. [1888.]
8534. **Yashevski, —.** Bit for Rotary Boring. *Gorn. Journ.*, 1872, t. 1, pp. 411-414.
8535. **Yates, J. A.** The Ottawa Gas-wells (Kan.). *Trans. Kansas Ac. Sci.*, vol. xviii, pp. 106-108. [1903.]
8536. **Yermoloff, A.** Nouvelles Recherches et Découvertes de Naphte dans le Caucase Occidental. *Ann. Mines*, ser. 10, t. xii, pp. 511-523. [1907.]
8537. **Young, —.** Report for the year 1905 on the Trade of Kansas City. *Dipl. Cons. Rep.*, ann. ser., no. 3622, pp. 75-80. [1906.]
8538. **Young, G. A., and E. W. Brock.** A Descriptive Sketch of the Geology and Economic Minerals of Canada. *Canada Geol. Surv.*, no. 1085. Pp. 151; 82 pls., 2 maps. [1909.]
8539. **Young, H.** Report for 1885, 1889-1892 on the Trade of Bilbao. *Dipl. Cons. Rep.*, ann. ser., nos. 31, 733, 923, 1054, 1278. [1886, 1890-1893.]
8540. **Young, J.** Some Account of Paraffin and Paraffin Oils. *Proc. Scot. Soc. Arts*, vol. vii, pp. 36-41. [1868.]
- Young, J., see Thorpe, J. E.**
8541. **Young, J. R.** Petroleum Trade in China. *Rep. Cons. U.S.A.*, vol. xiii, pp. 82-102. [1884.]
8542. **Young, S.** The Vapour Pressures, Specific Volumes, and Critical Constants of Normal Pentane, with a Note on the Critical Point. *Journ. Chem. Soc.*, vol. lxxi, pp. 446-457. [1897.]
8543. — The Vapour Pressures, Specific Volumes, and Critical Constants of Normal Heptane. *Ibid.*, vol. lxxiii, pp. 675-681. [1898.]
8544. — Composition of American Petroleum. *Ibid.*, pp. 905-920. [1898.]
8545. — Action of Chlorosulphonic Acid on the Paraffins and other Hydrocarbons as a Means of Purifying the Normal Paraffins. *Ibid.*, vol. lxxv, pp. 172, 173. [1899.]
8546. — Fractional Distillation. 8vo, London, 1903.
8547. **Young, S., and E. C. Fortey.** The Vapour Pressures, Specific Volumes, and Critical Constants of Hexamethylene. *Ibid.*, vol. lxxv, pp. 873-883. [1899.]
8548. **Young, S., and G. L. Thomas.** Some Hydrocarbons from American Petroleum. *Ibid.*, vol. lxxi, pp. 440-446. [1897.]
- Young, S., see Francis, F. E., Jackson, D. H., and Thomas, G. L.**
8549. **Young, W.** Further Developments of the Peebles Process. *Journ. Gaslighting*, vol. lxiv, pp. 236-238, 326-329. [1894.]
8550. **Young, W.** Vertical Retorts for the Production of Illuminating Gas. *Journ. Gaslight.*, vol. xxiii, pp. 560-564. [1906.]
8551. **Young, W. G.** The M'Kittrick Oil Field in California. *Eng. Min. Journ.*, vol. lxxi, pp. 30, 31. [1901.]
8552. — Submarine Oil Wells in California. *Ibid.*, p. 64. [1901.]
8553. — The Coalinga Oil Field, California. *Ibid.*, pp. 403, 404. [1901.]
8554. — The Present Condition of the Petroleum Industry in California. *Ibid.*, vol. lxxii, pp. 227, 228. [1901.]
8555. — The Increased Consumption of Petroleum in California. *Ibid.*, p. 427. [1901.]
8556. — The Present Outlook for the California Oil Industry. *Ibid.*, p. 664. [1901.]

8557. **Young, W. G.**, The Present Condition of the Oil Industry of California. *Eng. Min. Journ.*, vol. lxxiv, pp. 545, 546. [1902.]
8558. **Yuill, A.** The Practical Results of Enriching Gas by the Peebles Process at the Alloa Gas-Works. *Ibid.*, vol. lxxiv, pp. 234-236, 278-280. [1894.]
8559. **Yule, H.**, and **T. Oldham.** Narrative of Major Phayre's Mission to the Court of Ava, with Notices of the Country, Government, and People; and Notes on the Geological Features of the Banks of the River Irrawady, and of the Country North of the City of Amarapura. 4to, *Calcutta*, 1856.
8560. ——— A Narrative of the Mission sent by the Governor-General of India to the Court of Ava in 1855, with Notices of the Country, Government, and People. 4to, *London*, 1858.
8561. **Yunge, G.** Estadística Minera de Chile en 1904-1909, encomendada a la Sociedad Nacional de Minería. T. II-IV. 8vo, *Santiago de Chile*, 1907-1910.
8562. **Yuschkín, E.** [Geological Sketch of the Khidirzindi Oil-field, in Reference to the Economic Results of Boring Operations.] *Trudi Bak. Old. I. R. Techn. Obsch.*, 1897, pp. 231-271, map.
8563. ——— [Search for Oil in the Baku Government, especially at Khidirzindi.] *Gorn. Journ.*, 1897, t. 2, pp. 78-91.
8564. ——— [Grozni Oil-field.] *Ibid.*, t. 4, pp. 45-59.
8565. ——— [Coal in Oil-fields.] *Ibid.*, 1898, t. 3, pp. 94-96.
8566. ——— [Geology of the Khidirzindi Oil-field.] *Ibid.*, pp. 350-362, map.
8567. ——— [Electric Lighting of Oil-Works.] *Ibid.*, 1899, t. 3, pp. 265-271.
8568. ——— [Plugging Oil-Wells in accordance with the Geological Structure of the Ground.] *Ibid.*, 1900, t. 3, pp. 36-44.
8569. ——— [Productive Wells of the Grozni Oil-field.] *Ibid.*, 1901, t. 3, pp. 334-350.
8570. ——— Note sur les lés de terrain de recherches a Grosnyl. *Journ. Pétr.*, t. 1, pp. 113, 114, 130, 131. [1901.]
8571. ——— [Statistics of Yield of Fountains and Pumping-Wells in the Grozni Field for 1901.] *Gorn. Journ.*, 1902, t. 3, pp. 360-367.
8572. ——— [Statistics of Grozni Petroleum Industry for nine months of 1903.] *Ibid.*, 1902, t. 2, pp. 106-120.
8573. ——— Geological researches in the Grozni Oil-field, 1901-1902. *Bull. Com. Géol. Russ.*, t. xxii, pp. 619-644, pl. [1903.]
8574. ——— [Sketch of the Operations in the Grozni Oil-field.] *Gorn. Journ.*, 1908, t. 2, pp. 239-250.
8575. ——— [Mining in the Kuban Province.] *Ibid.*, 1909, t. 3, pp. 274-282.
8576. ——— [The Maikop Oil Fields.] *Nepht. Dielo*, 1910.
8577. **Z., J.** Ueber Erdölseifen und ihre Löslichkeit im Petroleum. *Zeitschr. angew. Chem.*, bd. viii, pp. 225-229. [1895.]
8578. **Zadokhin, S. A.** [On the Regenerative System of Petroleum Distillation.] *Zap. Imp. Russk. Tekhn. Obsch.*, t. xliii, pp. 175-187. [1908.]
8579. **Zängerle, M.** Ueber die Anwendung des Petroleum zur Dampfkessel-Feuerung. *Kunst. Gewerbe-Bl.*, bd. liii, pp. 721-727. [1867.]
8580. ——— Ueber Aufbewahrung der Mineralöle. *Bayer. Ind.-Gewerbe-Bl.*, bd. i, pp. 155, 156. [1869.]
8581. **Zaloziecki, R.** [Olefines in Galician Petroleum.] *Kosmos*, t. xi, pp. 403-406. [1886.]
8582. ——— Ueber die Leuchtkraft von Erdöl. *Polyt. Journ.*, bd. cclx, pp. 127-137. [1886.]
8583. ——— Ueber Entfärbungsmittel und ihre Anwendung zur Entfärbung des Ozokerits. *Ibid.*, bd. cclxx, pp. 20-33, 72-79, 117-126. [1887.]
8584. ——— Ueber die Einwirkung des Schwefelsäure auf Ozokerit. *Ibid.*, pp. 178-184. [1887.]
8585. ——— Vergleichende Untersuchungen von Erdölbrennern. *Ibid.*, bd. cclxvii, pp. 265-274, 362-370. [1888.]
8586. **Zaloziecki, R.** Ueber die quantitative Bestimmung des Paraffins. *Polyt. Journ.*, bd. cclxviii, pp. 274-279. [1888.]
8587. ——— Ueber Paraffin im Erdöl. *Zeitschr. angew. Chem.*, bd. i, pp. 261-263, 318-331. [1888.]
8588. ——— Zur Entstehung des Erdöles. *Chem.-Zeit.*, bd. xv, pp. 1203-1205. [1891.]
8589. ——— Ueber die Bildung saurer Verbindungen im Erdöl. *Zeitschr. angew. Chem.*, bd. iv, pp. 416-419. [1891.]
8590. ——— Ueber die chemische Constitution der Sauerstoffverbindungen (Säuren) im Erdöl. *Ber. deutsch. chem. Ges.*, bd. xxiv, pp. 1808-1815. [1891.]
8591. ——— Zur Bildung von Erdöl und Erdwachs. *Polyt. Journ.*, bd. cclxxx, pp. 69-72, 85-89, 133-136. [1891.]
8592. ——— Bemerkungen zu der Abhandlungen von Kast und Seidner "Zur Bildung des Erdwachses." *Ibid.*, bd. cclxxxiv, pp. 252, 253. [1892.]
8593. ——— Ueber pyridinartige Basen im Erdöl. *Monatsch. Chem.*, bd. xiii, pp. 498-503. [1892.]
8594. ——— Ueber Erdölsäuren. *Chem.-Zeit.*, bd. xvi, pp. 905-907. [1892.]
8595. ——— Untersuchung einer Erdöl-Reinigungsanlage. *Polyt. Journ.*, bd. ccxc, pp. 258-261. [1893.]
8596. ——— Ueber terpenartige Kohlenwasserstoffe im Erdöl. *Ber. deutsch. chem. Ges.*, bd. xxvii, pp. 2081-2085. [1894.]
8597. ——— Ueber die Nothwendigkeit der Feststellung einheitlicher Untersuchungs-Methoden in der Petroleum Industrie. *Chem. Rev. Fett-Harz-Ind.*, bd. i, no. 25, pp. 1-3. [1895.]
8598. ——— Zur Theorie und Praxis der chemischen Reinigung von Mineralölen. *Ibid.*, no. 30, pp. 1-4. [1895.]
8599. ——— Ueber eine zur Bestimmung der Leuchtöl-ausbeute angepasste Modification des Destillierverfahrens der Rohöle. *Chem.-Zeit.*, bd. xx, pp. 645-648. [1896.]
8600. ——— Beiträge zur Kenntniss des chemischen Verhaltens der Erdöle. *Zeitschr. angew. Chem.*, bd. x, pp. 587-592, 619-623. [1897.]
8601. ——— [Remarks on the Fractional Distillation of Petroleum.] *Trudi Bak. Old. Imp. Russk. Techn. Obsch.*, kn. xii, pp. 225-230. [1897.]
8602. ——— Ueber Dissociation erdölsaurer Salze und die Bestimmung freier Säuren in Mineralölen. *Chem. Rev. Fett-Harz-Ind.*, bd. iv, pp. 25-27, 36-38. [1897.]
8603. ——— Die Verwerthung der Abfälle der Petroleumfabriken. *Ibid.*, bd. v, pp. 27-29. [1898.]
8604. ——— [Galician Export-petroleum.] *Naphta*, 1898, no. 15.
8605. ——— Der gegenwärtige Stand der Erdölindustrie. *Compt. Rend. Congr. internat. Chim. appl.*, sess. 3, t. iii, pp. 3-19. [1899.]
8606. ——— A Review of the Galician Petroleum Industry in 1898. *Petr. Rev.*, vol. 1, pp. 9-12. [1899.]
8607. ——— A Theoretical View of Ragonin's Method of Distillation. *Ibid.*, pp. 110-112. [1899.]
8608. ——— Die Selbstentzündlichkeit von Erdölproducten. *Naphta*, bd. viii, p. 33. [1900.]
8609. ——— Sind die Beabsichtigten Wirkungen der Zollerhöhung auf galizisches Rohöl eingetret, und haben die Forderungen nach einer Erhaltung dieser massregel ihre volle Berechtigung oder nicht? *Ibid.*, bd. ix, pp. 185-191. [1901.]
8610. ——— Die Projekt der Wasser-Wege vom Standpunkte der gal. Petroleum-Production. *Ibid.*, pp. 225-228. [1901.]
8611. ——— Technologische Rundschau auf dem Gebiete der Petroleum-Industrie. *Ibid.*, pp. 285-287, 303-306.
8612. ——— Die Rentabilitätsberechnung der galizischen Rohölgruben. *Ibid.*, pp. 348-351. [1901.]
8613. ——— Boryslaw—ein Zweites Baku? *Ibid.*, bd. x, pp. 260-262. [1902.]
8614. ——— Neuere Beiträge zur Hypothese der Erdölbildung. *Ibid.*, pp. 397-401. [1902.]

8615. **Zaloziński, R.** Der Export Galizischen Rohöles nach Deutschland. *Naphta*, bd. x, pp. 419-423, 442-446. [1902.]
8616. ——— Technische Rundschau auf dem Gebiet der Petroleum-Industrie. *Ibid.*, pp. 459-461, 479-484. [1902.]
8617. ——— Die Naphtafraktionierung auf kaltem Wege. *Ibid.*, bd. xi, pp. 394, 395. [1903.]
8618. ——— [On the Nitration of the Low-boiling Fractions of Galician Petroleum.] *Rozpr. Ak. Umiej. Krakow*, t. xliii, A, pp. 128-137. [1903.]
8619. ——— Das Problem des Löslichmachens der Mineralöle. *Chem. Rev. Fett-Harz-Ind.*, bd. x, pp. 158-160, 181, 182, 202, 203, 232-234, 252, 253. [1903.]
8620. ——— Der Charitchkoffsche Vorschlag der fraktionierten Trennung von Petroleum-Kohlenwasserstoffen auf kaltem Wege. *Ibid.*, bd. xi, pp. 26, 27, 43, 44. [1904.]
8621. ——— Qualität des österreichischen Exportpetroleums. *Naphta*, bd. xii, pp. 7-10, 21-23. [1904.]
8622. ——— Torf und Erdöl auf Basis eines gemeinsamen Destillations-Vorganges. *Ibid.*, pp. 53-57. [1904.]
8623. ——— Von der amerikanischem Petroleum-Industrie. *Ibid.*, pp. 212-215. [1904.]
8624. ——— Welche Wirkungen kann die Erneuerung der Handelsverträge auf die Petroleum-Industrie ausüben. *Ibid.*, pp. 273-275. [1904.]
8625. ——— Berichte aus der Technologie des Erdöls. *Ibid.*, pp. 307-312, 322-326, 338-342, 354-358, 374-379. [1904.]
8626. ——— Versuch des Torpedierens eines Rohöl-schachtes in Boryslaw, und einige daran geknüpfte Bemerkungen. *Ibid.*, bd. xiii, pp. 76-78. [1905.]
8627. ——— Statistik der russischen Petroleum-Industrie in Jahre 1904 verglichen mit 1903. *Ibid.*, pp. 111-114. [1905.]
8628. ——— Ueberproduktion von Erdöl. *Naphta*, pp. 250-254, 271-275. [1905.]
8629. ——— Eine neue Grundlage zur Feststellung der Rohölpreise. *Ibid.*, bd. xiv, pp. 63-67. [1906.]
8630. ——— Welche Mittel sind zu wählen, um eine Ausbreitung des Verwendungsgebietes der Petroleumprodukte anzustreben. *Ibid.*, pp. 183-186, 203-208, 223-225, 287-291, 307-310. [1906.]
8631. ——— Die Erdöl- (Petroleum-) und Erdwachs- (Ozokerit-) Industrie. *Boryslaw*, 1907.
8632. ——— Oelschachtbrände, ihre Ursachen und Mitte zu deren Verhütung. *Naphta*, bd. xvi, pp. 235-236. [1908.]
8633. ——— Neues Verfahren in der Paraffinfabrikation unter Verwendung von Prebshitzrohren. *Chem.-Zeit.*, bd. xxiv, p. 265. [1910.]
8634. ——— Ueber die optische Aktivität der Erdöle im Zusammenhange mit der Frage nach ihrem Ursprunge. *Compt. Rend. Congr. internat. Pétróle*, sess. 3, t. ii, pp. 719-736. [1910.]
8635. **Zaloziński, R.**, and **G. Frasch.** Untersuchung des galizischen Erdöles. *Ber. deutsch. chem. Ges.*, bd. xxxv, pp. 386-391. [1902.]
8636. **Zaloziński, R.**, and **L. Gans.** Ueber hochschmelzende feste Kohlenwasserstoffe aus den letzten Destillationsprodukten des Erdöls. *Chem.-Zeit.*, bd. xxiv, pp. 535, 536, 553-557. [1900.]
8637. **Zaloziński, R.**, and **J. Hausmann.** Studien über die chemische Zusammensetzung galizischer Erdöle. *Naphta*, bd. xv, pp. 251-254, 290-293, 311-314. [1907.]
8638. **Zaloziński, R.**, and **H. Klarfeld.** Bestimmung der Korrekturen für die spezifischen Gewichte und der Ausdehnungskoeffizienten des Boryslawer und Tustanowicer Rohöles. *Chem. Rev. Fett-Harz-Ind.*, bd. xiii, pp. 213-216. [1906.]
8639. ——— Ueber die optische Aktivität der Erdöle im Zusammenhange mit der Frage nach ihrem Ursprunge. *Chem.-Zeit.*, bd. xxxi, pp. 1155, 1156, 1170-1172. [1907.]
8640. **Zamyatin, A. N.** [Explanation of the map of the Ukhta Oilfield, Arkhangel]. *Bull. Com. géol. Russ.*, t. xxix, Journ., pp. 6-10, pl. 1. [1910.]
8641. **Zaranski, J.** Zur Frage der Einführung eines Petroleum-Monopols in Oesterreich. *Petroleum Zeitschr.*, bd. v, p. 949. [1910.]
8642. **Zaring, W. C.** Reports of State Supervisor of Oil Inspection for 1900-1902. *Ann. Rep. Dep. Geol. Indiana*, vol. xxv, pp. 477-480; vol. xxvi, pp. 445-448; vol. xxvii, pp. 473-476. [1901-1903.]
8643. **Zaringer, —**. Das Gefrierverfahren und seine neueste Entwicklung. *Org. Ver. Bohrtechn.*, bd. xvii, pp. 247-256. [1910.]
8644. **Zarubin, P.** [On Town Lighting generally, and on the "Daylight Lamp" Gas System.] *St. Petersburg*, 1875.
8645. **Zatsvilkovski, —**. [Economic Lighting, "Daylight Lamp."] *St. Petersburg*, 1876.
8646. **Zehring, W. S.** Active Development in the Oil Fields of Utah. *Mining World*, vol. xxxiv, pp. 596, 597. [1911.]
- Zelikov, I.**, see **Zelinsky, N. D.**
8647. **Zelinsky, N. D.** Versuch eines Synthese von Naphthenen. *Ber. deutsch. chem. Ges.*, bd. xxxviii, pp. 780-783. [1895.]
8648. ——— Zur Kenntniss des Hexamethylens. *Ibid.*, pp. 1022-1025. [1895.]
8649. ——— Untersuchungen in der Hexamethylenreihe. v. Ueber die Isomerisation des Hexamethylens. *Ibid.*, bd. xxx, pp. 387-391. [1897.]
8650. ——— vi. Ueber Isomerisation von Methylhexamethylen. *Ibid.*, pp. 1532-1540. [1897.]
8651. ——— Zur Kenntniss des Hexamethylens. *Ibid.*, bd. xxxiv, pp. 2799-2803. [1901.]
8652. ——— Ueber optisch active Kohlenwasserstoffe in der Cyclopenten- und Cyclohexen-Reihe. *Ibid.*, bd. xxxv, pp. 2488-2494. [1902.]
8653. ——— [Optically-active, saturated, cyclic Hydrocarbon (Naphthenes).] *Journ. Russk. Fiz. Khim. Obsch.*, t. xxxiv, otd. i, pp. 245, 246. [1902.]
8654. ——— [Cyclononane.] *Ibid.*, pp. 847, 848.
8655. ——— [Transformation of Petroleum Hydrocarbons into Fatty Acids and Fats.] *Ibid.*, pp. 968-971. [1902.]
8656. ——— [On the Production of Aromatic Hydrocarbons from Petroleum.] *Ibid.*, otd. 2, pp. 1-4. [1902.]
8657. ——— [Action of Oxygen on the Magnesi-organic Compounds of Chlorides of Petroleum Hydrocarbons. *Ibid.*, t. xxxvi, pp. 767, 768. [1904.]
8658. **Zelinsky, N. D.**, and **A. Generosow.** Untersuchungen in der Hexamethylenreihe. iv. (Synthese von Heptanaphthenen). *Ber. deutsch. chem. Ges.*, bd. xxix, pp. 729-733. [1896.]
8659. **Zelinsky, N. D.**, and **S. Naumov.** Untersuchungen in der Hexamethylenreihe. vii. Ueber 1-4-Dimethylhexamethylen (Synthese eines zweiten Octonaphthens). *Ibid.*, bd. xxxi, pp. 3206-3208. [1898.]
8660. **Zelinsky, N. D.**, and **A. N. Reformatsky.** Untersuchungen in der Hexamethylenreihe. iii. Synthese des Nononaphthens. *Ibid.*, bd. xxix, pp. 214-216. [1896.]
8661. **Zelinsky, N. D.**, and **V. Rudevitch.** Synthetische Versuche in der Hexamethylenreihe. *Ibid.*, bd. xxviii, pp. 1341-134. [1895.]
8662. **Zelinsky, N. D.**, and **M. Rudsky.** Synthetische Versuche in der Pentamethylenreihe. *Ibid.*, bd. xxix, pp. 493-495. [1896.]
8663. **Zelinsky, N. D.**, and **I. Zelikov.** Ueber Trimethyltrimethylene. *Ibid.*, bd. xxxiv, pp. 2856-2867. [1901.]
8664. **Zengelis, C.** Ueber einen Retinit in Thessalien. *Min. petr. Mitth.*, bd. xx, p. 356. [1901.]
8665. **Zeno, —**. [Mineralogy of Prague.] *Nouv. Recr. Phys.*, 1770.
8666. **Zepharovich, V. v.** Bericht über die Schürfrungen auf Braunkohle zwischen Prizlitz und Krapina und ein Vorkommen von Bergtheer zu Pekenicza an der Mur in Croatien. *Jahrb. k.-k. geol. Reichs.*, bd. vii, pp. 738-746. [1896.]
8667. ——— [Mineralogisches Lexicon für des Kaiserthum Oesterreich. 8vo, Vienna, 1859.]
- Zeppa, P.**, see **Balbiano, L.**

8668. **Zetter, J. T.** Der Asphalt und seine Verwendung in der Bautechnik. *Techn. Mith. Schweiz. Ing.-Archit. Ver.*, h. xix, p. 28. [1880.]
8669. **Zeuschner, L.** Geognostische Reise in Karpathen. *N. Jahrb.*, 1833, pp. 316-319; 1836, pp. 353-359.
8670. **Zezi, P.** Osservazioni geologiche fatte nei dintorni di Ferentino e di Frosinone nella provincia di Roma. *Boll. R. Com. geol. Ital.*, vol. vii, pp. 360-388. [1876.]
8671. **Zelenkhi, V. K.** [Oil-springs in Russian Poland.] *Verh. russ. k. min. Ges.*, f. 2, bd. xv, pp. 25-30. [1880.]
8672. ——— [Oil Deposits of Khidirzindi, Uitasch and Salyani.] *Obsch. Gorn. Ing.*, 1897.
8673. **Ziborov, M. N.** [Report on the Competition of Oil Stoves and Furnaces for the War Office Prize, 1891-92.] *Zap. Imp. Russk. Tekhn. Obsch.*, g. xxvii, Mar., pp. 9-44. [1893.]
8674. **Ziem, —** Schmiermittel und ihre Prüfung. *Zeitschr. Ver. deutsch. Ing.*, bd. li, pp. 471-472. [1907.]
- Zilkens, F.** see **Werner, A.**
8675. **Zimmermann, A. P.**, and **M. A. Unanov.** [Separate Opinions of Members of the Committee on the Continuous Still.] *Trudi Bakinsk. Od. Imp. Russk. Tekhn. Obsch.*, 1892, pp. 56-63.
8676. **Zimmermann, F.** Die Mineralöl- und Paraffin-fabrication in der Provinz Sachsen. *Zeitschr. Berg- u. Hüt.-Salinenw.*, bd. xiii, pp. 62-92. [1865.]
8677. **Zincken, C. F.** Die Fundorte von Steinöl und Asphalt. *Deutsch. Ill. Gewerbezeit.*, bd. xxix, pp. 9-11, 26, 27, 41-43, 65-67. [1864.]
8678. ——— Die Physiographie der Braunkohle. 8vo, *Leipzig*, 1867.
8679. ——— Ergänzungen zur Physiographie der Braunkohle. *Halle*, 1871.
8680. ——— Die Mineralschätze des europäischen Russlands. *Berg- u. Hüt. Zeit.*, bd. xxxix, pp. 49-51, 101-104, 116-118, 132-134, 137-139, 147-149, 163-166, 183-185, 194-196, 211-213, 224-226, 233-235, 240-242, 253-255, 301-304, 313-315, 339-341, 360-361, 376-378, 405-407, 411-414, 423-426, 429-431, 444-446, 457-460, 467-474. [1880.]
8681. ——— Gedanit. *Ibid.*, p. 73. [1880.]
8682. ——— Das Vorkommen von Bergtheer und Asphalt bei Ehlingen an der Donau in Schwaben. *Ibid.*, bd. xii, p. 63. [1882.]
8683. ——— Angeblicher Oelfund auf der Saline Neu-Sulza bei Stadt Sulza. *Ibid.*, p. 66. [1882.]
8684. ——— Die geologische Horizonte der fossilen Kohlen. Die Vorkommen der fossilen Kohlenwasserstoffe, Erdöl, Asphalt, bituminöser Schiefer, Schwellkohle, Bernstein, Kopal, etc. Nebst einem Anhang: Die Kosmischen Kohlenwasserstoffe. 3 Bde. 8vo, *Leipzig*, 1883, 1884.
8685. ——— Aphorismen über fossile Kohlen und Kohlenwasserstoffe. *Oesterr. Zeitschr. Berg-Hüt.*, bd. xxxii, pp. 745, 746. [1884.]
8686. ——— Die Vorkommen von Erdöl, Asphalt, Kohlenwasserstoffgassen, bituminösen Schiefen, Steinkohlen, etc., in Amerika. *Ibid.*, bd. xxxiv, pp. 51-53, 75-76, 88-92, 109-111, 125-129, 141-144, 175-178. [1886.]
8687. ——— Das Naturgas Amerikas, nach A. Williams, C. Zincken, C. A. Ashburner, etc. *Ibid.*, bd. xxxv, pp. 215-220, 229-234. [1887.]
8688. ——— Das Vorkommen der natürliche Kohlenwasserstoffe und der änderen Erdgase. 4to, *Halle*, 1890.
- Zincken, C. F.**, see **Hilgard, E. W.**
8689. **Zincken, J. C. L.** Ueber die Leuchtkraft der Destillationsproducte der Braunkohle, etc. *Polyt. Journ.*, bd. civ, pp. 128-139, 215-229. [1860.]
8690. ——— Untersuchungen über die Leuchtkraft der Producte der Gerstewitzer Photogen- und Paraffin-fabrik. *Zeitschr. ges. Nat.*, bd. xxii, pp. 341-360. [1863.]
- Zinina, —**, see **Butlerow, A. I.**
8691. **Zipperlen, —**. Recherches du Pétrole à Gabian (Héranit). *Compt. rend. Soc. industr. min.*, 1885, pp. 5, 6.
8692. **Ziurek, —**. [American Petroleum.] *Verh. Ver. Beford. Gewerbl. Preuss.*, bd. xii, pp. 144. [1862.]
8693. **Zmerzikar, —**. Galizische Petroleum-Industrie. *Zeitschr. angew. Chem.*, bd. x, p. 71. [1897.]
8694. **Zoëga, —**. Om den sammenhaengende Destillation. *Tidskr. Nat.*, bd. iii, pp. 161-167. [1824.]
8695. **Zolesi, D.**, and **D. Molo.** Un po' di storia sul petrolio. *Genoa*, 1878.
8696. **Zolotarev, L. A.** [Double-striking self-rotating Boring Machine, with cross-headed chisels for cable-boring deep holes.] *Trudi Bakinsk. Od. Imp. Russk. Tekhn. Obsch.*, 1889-1891, pp. 98-103. [1892.]
8697. **Zoppetti, V.** Distretto di Milano. *Rel. Serv. Min.*, 1880, pp. 206-230; *Riv. Serv. Min.*, 1891, pp. 191-235; 1892, pp. 171-198. [1883, 1893, 1894.]
8698. **Zuber, R.** [Fresh Finds of Petroleum in the Carpathians.] *Kosmos*, t. v, pp. 101-103. [1880.]
8699. ——— [Note on Olsewski's Article.] *Ibid.*, t. vi, pp. 577-580. [1881.]
8700. ——— Detail-Studien in den ostgalizischen Karpathen zwischen Delatyn und Jablonow. *Jahrb. k.-k. geol. Reichs.*, bd. xxxii, pp. 351-372. [1882.]
8701. ——— Nene Oelzone in Ostgalizien. *Gornik*, bd. iii, p. 56. [1884.]
8702. ——— Informe sobre el Pétroleo de la Laguna de la Brea (Provincia de Jujuy, Republica Argentina). *Bol. Ac. Nac. Ci. Cordoba*, t. x, pp. 442-447. [1889.]
8703. ——— Estudio geológico del Cerro de Cacheuta y sus contornos. *Ibid.*, pp. 448-472, 2 pls. [1889.]
8704. ——— Informe sobre los Terrenos Petrolíferos del Departamento de San Rafael (Provincia de Mendoza). *Ibid.*, t. xii, pp. 370-378, 2 pls. [1890.]
8705. ——— [Notes on the Theories of the Origin of Petroleum.] *Naphtha*, 1895.
8706. ——— Karte der Petroleum-Gebiete in Galizien. 4to, *Lemberg*, 1897.
8707. ——— Petroleum und Salz in Rumänien. *Zeitschr. prakt. Geol.*, bd. v, p. 224. [1897.]
8708. ——— Kritische Bemerkungen über die modernen Petroleum-Entstehungs-Hypothesen. *Ibid.*, bd. vi, pp. 84-94. [1898.]
8709. ——— Geologie der Erdöl-Ablagerungen in den Galizischen Karpathen. 8vo, *Lemberg*, 1899.
8710. ——— Geological Sketch of the Oil-fields of the Apseron Peninsula. *Petr. Rev.*, vol. i, pp. 660, 661. [1899.]
8711. ——— Ueber die Entstehung des Flysch. *Zeitschr. prakt. Geol.*, bd. ix, pp. 283-289. [1901.]
8712. ——— Die geologischen Verhältnisse von Boryslav in Ostgalizien. *Ibid.*, bd. xii, pp. 41-48. [1904.]
8713. ——— Die geologische Verhältnisse der Erdölzone Opaka-Schodnicka-Urycz in Ostgalizien. *Ibid.*, pp. 73-85. [1904.]
8714. ——— A New Oil Region in Eastern Galicia. The Development of Niebylow. *Petrol. World*, vol. ii, pp. 462, 463. [1905.]
8715. ——— Sur les Relations entre le Flysch et le Pétrole. *Compt. Rend. Congr. internat. Pétrole*, sess. 3, t. ii, pp. 139, 140. [1910.]
- Zuber, R.**, see **Hauthal, R.**; and **Kreutz, F.**
8716. **Zubkov, —**. [On a-Deknaphtene.] *Jurn. russk. fiz. khim. Obsch.*, g. xxv, otd. i, pp. 382-385. [1893.]
8717. **Zubov, P.** [Heats of Combustion of some Organic Compounds.] *Ibid.*, g. xxx, pp. 926-950. [1898.]
8718. **Zundel, C.**, and **M. Mieg.** Notice sur quelques Sondages aux environs de Mulhouse et en Alsace. *Bull. Soc. Ind. Mulh.*, t. xivii, pp. 631-641. [1877.]
8719. **Zunth, H.** De Balneo thermali Lixignano vocato, necnon de luto Barboliorum medicato in ducatu Parmensi. 4to, *Venice*, 1615.

**A SELECTION OF ANONYMOUS WORKS**  
(Chronologically Arranged).

8720. Sur l'huile de petrol. *Hist. Acad. Roy. Sci.*, 1715, pp. 15-18.
8721. [Oil of Montechiaro, Piacenza.] *Hist. Acad. Roy. Sci.*, 1736, pp. 56, 57.
8722. Description des Sources de Naphte de Baku, près Derbens sur la Mer Caspienne; tirée de l'Histoire des Découvertes faites par différens savans Voyageurs Russes. *Journ. Phys.*, t. xx, pp. 161-166. [1782.]
8723. Notice sur les produits bitumineux de Lobsann. 8vo, *Strassburg*, 1825.
8724. [Mineralogical and Statistic Notes on Grusinia.] *Gorn. Journ.*, 1825, kn. iii, pp. 1-13.
8725. Theoretical and Practical Essay on Bitumen, setting forth its Uses in remote Ages and Revival in Modern Times, and demonstrating its applicability to various Purposes. *London*, 1839.
8726. Bericht über die, im Auftrage des Königlichen Ministeriums des Innern, von der Direktion der höheren Gewerbeschule zu Hannover angestellten Versuche über Asphalt-Pflasterung. *Mitth. Gewerbe-Ver. Hannover.*, 1838-1839, pp. 295-320.
8727. Die Anwendbarkeit des Westphälischen Asphaltes zu Trottoir und Fahrbahnen. *Arch. Min. Geogn.*, bd. xiv, pp. 587-590. [1840.]
8728. Report of a Committee for the Investigation of the Coal and Mineral Resources of India, May 1845. Fo, *Calcutta*, 1845.
8729. Report from the Select Committee on Coal. . . . *Sydney*, 1847.
8730. [Description of the Transcaucasian Mineral Localities found from 1799 to 1845.] *Gorn. Journ.*, 1851, t. 1, pp. 91-128, 241-256.
8731. St. Domingo Petroleum and Trinidad Asphalt. *London*, 1860.
8732. Catalogue of the Natural and Industrial Products of New South Wales, exhibited in . . . Sydney . . . 1861. 8vo, *Sydney*, 1861.
8733. On the Carburation of Illuminating Gas by Purified Petroleum, and on the Manufacture of Gas from the Crude Petroleum of Canada and the U.S. *Journ. Board Arts Manuf. Upper Canada*, vol. ii, pp. 1-4. [1862.]
8734. The Canadian Native Oil; its story, its uses, and its profits, with some account of a visit to the oil wells. 8vo, *London*, 1862.
8735. Marietta and the Oil and Mineral Regions of South-eastern Ohio and West Virginia. *Marietta*, 1864.
8736. Derrick and Drill, or an Insight into the Discovery, Development, and Present Condition and Future Prospects of Petroleum, in New York, Pennsylvania, Ohio, West Virginia, etc. 12mo, *New York*, 1865.
8737. The Oil District of Canada. *New York*, 1865.
8738. Petroleum and Shale Oil. Report of the Experiments . . . at Woolwich Dockyard, with the view of testing the value of Petroleum and Shale Oil as substitutes for Coal in raising Steam in Marine Boilers. Admiralty Publication, Fo, *London*, 1866.
8739. A Catalogue of Minerals, Rocks, and Fossils which have been collected in the Colony by the Mining Department, Victoria. 8vo, *Melbourne*, 1866.
8740. Bericht über die Durchforschung des Naphta-Districts im Trans-Kuban Gebiete und auf der Halbinsel Taman im Sommer 1866. *Tiflis*, 1867.
8741. Correspondence, etc., respecting the Existence of Petroleum in New South Wales. Fo, *Sydney*, 1867.
8742. Notes on the Discovery of Petroleum in North Italy, and the Prospects of the "Apennine Petroleum Company, Limited." 8vo, *London*, 1868.
8743. Notice sur la Roumanie, suivi de catalogue spécial des produits exposés dans la section Roumaine à l'Exposition Universelle de Paris en 1867. *Paris*, 1868.
8744. Del Prodotti di varie Arti ed Industrie inviata all' Esposizione Universale del 1867 in Parigi. Relazione della Sottocommissione Industriale di Firenze al Ministro di Agricoltura Industria e Commercio. 1868.
8745. Punjab Administration Reports, 1868-1890. *Lahore*, 1869-1891.
8746. Report of the Committee of the New York Board of Fire Underwriters. Report of the Committees on Gas Machines, Carbureters, etc. *New York*, 1869.
8747. Report of the Commission of Inquiry to Santo Domingo. . . . Map. 8vo, *Washington*, 1871.
8748. Report from the Select Committee of the House of Lords on the Petroleum Bill (H.L.); with Proceedings, Evidence, etc. Fo, *London*, 1872. *Idem*, 1883. *Idem*, 1894-1896.
8749. Burmese Administration Reports, 1873-1884. *Rangoon*.
8750. [Report on Mining Industry of Russia for ten years.] *Gorn. Journ.*, 1874, t. 1, pp. 1-36.
8751. Descriptive Catalogue of a Collection of the Economic Minerals of Canada, and notes on a stratigraphical collection of rocks [Philadelphia Exhibition]. *Montreal*, 1876.
8752. A Brief History of Petroleum. *Philadelphia*, 1876.
8753. [On Measures for the Removal of Obstacles to the Growth of the Oil Industry.] *Zap. Imp. Russk. Tekhn. Obsch.*, g. x, otd. 1, pp. 158-169. [1876.]
8754. Aperçu des richesses minérales de la Russie d'Europe. 1878.
8755. [On the Investigation of various Methods of Testing Kerosene.] *Zap. Imp. Russk. Tekhn. Obsch.*, g. xiv, otd. 1, pp. 21-27. [1880.]
8756. Materialien zur technische Begründung eines Entwurfes von Vorschriften über den Verkehr mit Petroleum, nebst Zeichnungen vom kaiserl. Gesundheitsamte. *Berlin*, 1880.
8757. Protocoll über die Verhandlung en des Commission zur Auswahl eines Petroleumprobes. *Berlin*, 1881.
8758. [On the Question of the Baku Petroleum Industry.] *Zap. Kavk. Otd. Imp. Russk. Tekhn. Obsch.*, t. xiii, pp. 205-214. [1881.]
8759. Relazione e Memorie della Esposizione Artistica-Industriale-Didattica della Società operaie di mutuo soccorso della regione Abruzzese tenutasi nel Settembre del 1880. *Chieti*, 1881.
8760. [On fixed Methods for the flash-points of Kerosene, and on the prohibition of the sale of merchandise dangerous to use.] *Zap. Imp. Russk. Tekhn. Obsch.*, g. xvi, otd. 1, pp. 207-212. [1882.]
8761. Vorschriften, betr. den Abel'schen Petroleumprobe, etc., von der kais. Normal-Aichungs Commission. *Berlin*, 1883.
8762. The Russian Petroleum Industry. *Engineering*, vol. xxxvii, pp. 171-173, 212, 213, 258-260, 296, 301, 302, 329, 330, 376-378, 440-442, maps and plates. [1884.]
8763. Gesetze und Verordnungen über die Bollbehandlung und Besteuerung des Mineralöles. Ed. by E. Bernatzky v. Treuwart, A. Carmine, and L. Joas. 12mo, *Vienna*, 1884.
8764. Report on Natural Gas for Industrial Purposes. *Trans. Amer. Soc. Mech. Eng.*, vol. v, pp. 340-378. [1884.]
8765. Karte des Petroleumvorkommens im Unter-Elsass im Massstab 1:80,000, mit einer graphischen Uebersicht über die Tiefen der erbohten Oel-vorkommen im Massstab 1:2000. Fo, *Strassburg*, 1885.
8766. Notes on Products of the Makum Coal-measures exhibited by the Assam Railways and Trading Co., Ltd., at the Colonial and Indian Exhibition. *London*, 1886.
8767. [On the Baku-Batum Pipeline.] *Zap. Imp. Russk. Tekhn. Obsch.*, g. xx, Trudi I. Otd., pp. 160-174. [1886.]
8768. Mittheilungen über die Baku'sche Oelindustrie in Allgemeinen, sowie über die Naphtahelzung im Besonderen. *Verh. Ver. Beförd. Gewerbß. Preuss.*, bd. lxvi, pp. 535-548. [1887.]



8769. Report of the Select Committee of the Senate appointed to inquire into the resources of the Great Mackenzie Basin. *Ottawa*, 1888.
8770. Statement showing quantities and value of important Minerals produced in each British Province and Native State of India, 1888. *Fo, Calcutta*, 1889.
8771. Congress der Naphtaindustriellen. Statistische Daten über russische und amerikanische Naphtaindustrie, 1890.
8772. Die Mineralöl und Paraffinabriken der Riebeck'schen Montanwerke bei Halle. *Polyt. Journ.*, bd. cclxxvii, pp. 426-431, 460-474. [1890.]
8773. Report of the Select Committee of the Senate on certain documents relating to the resources of the Great Mackenzie Basin. *Ottawa*, 1891.
8774. Correspondence respecting the Passage of Petroleum in Bulk through the Suez Canal. *Fo, London*, 1892.
8775. [Report of the Society's Committee for determining the type of heavy Kerosene, and enquiring into the means of increasing the percentage-yield of Illuminating Oil.] *Trudi Bakinsk. Otd. Imp. Russk. Tekhn. Obsch.*, 1889-1891, pp. 139-144. [1892.]
8776. Asphalt Paving. Report . . . on asphaltic materials available for street pavements in Philadelphia (Philad. Municipal Assoc.). *8vo, Philadelphia*, 1894.
8777. Mines and Minerals. Annual General Reports upon the Mineral Industry, 1894-1896. *Fo, London*, 1895-1897.
8778. Statistics of Mineral Production in India, 1894-1898; 1899-1909. *Fo, Calcutta*, 1900, 1910.
8779. Review of the Transcaspien Province in 1893. *8vo, Askhabad*, 1895.
8780. Skizzen-Sammlung von Gas- und Petroleum-Motoren. Eine Auswahl bewährter Ausführungen Petroleum-Maschinen. *4to, Munich*, 1896.
8781. The Fuel-gas System of E. P. Reichhelm and G. Machlet. *4to, New York*, 1897.
8782. Mines and Quarries. General Reports and Statistics, 1897-1911. *Fo, London*, 1898-1912.
8783. The Derrick's Handbook of Petroleum. A complete Chronological and Statistical Review of [American] Petroleum Developments from '59 to '98. *8vo, Oil City, Pa.*, 1898.
8784. The State of Wyoming, 1898.
8785. Statement showing the Production and Consumption of Coal . . . , together with a Statement showing the Production of Petroleum in the United States and in the Russian Empire for a series of years (in continuation of Parliamentary Paper No. 1 of Session 1897). *London*, 1898.
8786. [Proceedings of Commission appointed to fix a compulsory standard for the Flashing-point of Petroleum Residues.] *Zap. Imp. Russk. Tekhn. Obsch.*, g. xxxiii, Trudi, pp. 357-371. [1899.]
8787. Mines and Minerals of California. *8vo, San Francisco*, 1899.
8788. Wyoming. A Complete and Comprehensive Description of the Agricultural, Stock-raising, and Mineral Resources of Wyoming. The Resources and Attractions of Wyoming for the Home-seeker, Capitalist, and Tourist. *8vo, Omaha*, 1899.
8789. Gas and Oil Engines in Foreign Countries. *U.S. Special Cons. Rep.*, vol. xxiii. Pt. I, pp. 188, iv. [1901.]
8790. Vorschriften für die einheitliche Prüfung von Mineral-Schmierölen. *Oesterr. Chem.-Zeit.*, bd. iv, pp. 202, 203.
8791. Durchführungserläuterungen zu den Vorschriften . . . 1901. *Ibid.*, bd. v. pp. 2-7. [1902.]
8792. [Commission on the Question of Regulations for protecting the Baku Oil sands from access of Water by Plugging Boreholes.] *Bull. Com. géol. Russ.*, t. xxii, Journ., pp. 74-81. [1903.]
8793. [Rules for the Transport of Petroleum in Ships and for the use of Oil Fuel on them.] *Zap. Imp. Russk. Tekhn. Obsch.*, g. xxxvii, pp. 705-730. [1903.]
8794. The Alaskan Petroleum Fields. *Ann. Rep. Gov. Alaska to Sec. of Interior*, 1903.
8795. Report . . . of tests conducted on the Hohenstein water tube boiler showing the relative evaporative efficiencies of Coal and Liquid Fuel under forced and natural draft conditions. U.S. Naval Liquid Fuel Board. *8vo, Washington*, 1904.
8796. Arbeiten der mit dem Studium der Petroleum-Regionen betrauten Kommission. *4to, Bucharest*, 1904.
8797. Mexico. Geographical Sketch, Natural Resources, Laws, Economic Conditions, Actual Developments, Prospects of Future Growth. *Internat. Bur. Amer. Republ.*, Washington, 1904.
8798. Handbuch der Kaliwerke, Salinen, Erdöl- und Tiefbohruntersuchungen. *Berlin*, 1905.
8799. Report of the Fuels Committee of the Motor Union of Great Britain and Ireland, with evidence, and memoranda on petroleum, petroleum spirit, paraffin, shale spirit, benzol, alcohol, etc, and a bibliography. *4to, London*, 1907.
8800. Petroleum Refining. U.S. Census of Manufactures, 1905. *Bull. Dept. Commerce*, no. 70. Pp. 57, 4 pls. [1907.]
8801. Bericht der Expertenkommission der internationalen Ausstellung für Beleuchtung zu St. Petersburg. 1909.
8802. Mining in Japan, Past and Present. (Dep. Agric. Comm. Japan), *Tokyo*, 1909.
8803. Oil, Petroleum and Bitumen Manual. *8vo, London*, 1910.
8804. Conservation as it Affects the Oil Industry of California. *Proc. Amer. Mining Congr.*, vol. xiii, pp. 62. [1910.]

## ADDENDUM.

CONSIDERABLE attention has for many years been directed to the remarkable results which have been obtained in the employment of fuel by what is known as the Bonecourt system of surface combustion, and as this system is applicable to the burning of liquid fuel some particulars of it should be given.

The process, which is the invention of Professor William A. Bone, D.Sc., F.R.S., and Mr. C. D. McCourt, may be carried out by two alternative methods. The first of these, which is termed the diaphragm process, consists in causing a homogeneous mixture of combustible gas and air in suitable proportions to flow under slight pressure through a porous diaphragm of refractory material, with the result that it burns without flame at the surface of exit, and the diaphragm is thus maintained in a highly incandescent state.

When the second method, which is termed the granular-bed process, is to be adopted, a bed of suitably sized granules of the refractory material is prepared, and the mixture of gas, or vapour, and air, in their combining proportions, is injected through a suitable orifice into this granular bed, at a speed greater than the velocity of back-firing, combustion being thus instantaneously completed without flame, with the result that a temperature of 2000° C. can be maintained. The granules can be packed into boiler tubes, round crucibles, or formed into a bed for furnace work, and it is claimed that for steam-raising an efficiency of 95 per cent. has thus been obtained.

It is further claimed that if fuel oil, effectively atomised and mixed with the proper proportion of air for complete combustion, is injected into the previously heated mass of granules it can thus be used as effectively as a gaseous fuel.

# INDEX.

*N. ote.*—The numbers following the letters *br.* (=bibliographical reference) refer to the entries in the Bibliography, vol. iii. pp. 1155-1317.

	PAGE		PAGE
ABANDONMENT of wells .....	421	Algal wax.....	<i>br.</i> 8206
Abel, Sir F., testing petroleum .....	767, 778	Algeria; crude petroleums, specific gravity and flashing-point .....	265
— and lamp accidents .....	904	— crude petroleum commercial products .....	49
— and Sir B. Redwood, lamp accidents.....	906	— petroleum deposits, historical .....	184
— — construction and management.....	775	— — distribution .....	184
— cup and stirrer .....	769	— (general) .... <i>br.</i> 719, 1184, 1186, 1187, 1277, 1892, 5208, 5555, 5563, 5600	639
— test .....	<i>br.</i> 3235, 7381, 8761	Alison, F., cooling and sweating apparatus .....	870
— apparatus and directions.....	785	Alkali test for Russian petroleum products .....	870
Abel-Pensky petroleum flash-point tester .....	793	Alkaline naphtha residues; distillation .....	<i>br.</i> 4653
— — — Braun's modification.....	183	Alkalis; regeneration.....	<i>br.</i> 6027, 6028
Abruzzo, petroleum in .....	<i>br.</i> 5602	Alkaloid bases in petroleum and paraffin .....	445, 8277
Absorption plants .....	938	Allegheny oil-fields .....	<i>br.</i> 1405, 1545, 101, 224
Accidents .....	441, 697	Allen, A. H.; detection of rosin oil .....	875
— with lamps .....	904	— neutrality test for mineral oils .....	875
Acenaphthene .....	319	Alligator grab .....	386
Acetaldehyde in petroleum products.....	<i>br.</i> 6610	“Alpha” gas-making machine.....	915
Acetone from lubricating oils .....	<i>br.</i> 2929	Alsace, <i>see</i> Elsass .....	178, 180, 182
Acetylene or alkynes .....	306, 315	Altkirch district, Alsace; petroleum deposits .....	43
— explosive properties of .....	<i>br.</i> 138	Aluminium in petroleum ash .....	303
Acid content of oils; testing .....	<i>br.</i> 3453, 3455	— action of petroleum products on .....	<i>br.</i> 3912
— sludge; valuation of .....	<i>br.</i> 4656	Amaze oil-field, Japan .....	75
— tar; use of .....	<i>br.</i> 7705	America; composition of natural gas from .....	342
Acids in petroleum .....	322, 324	— oil-fields of .....	<i>br.</i> 562, 1757, 1907, 2383, 2384, 2536, 3382, 3397, 4945, 6950
— regeneration of .....	<i>br.</i> 6027, 6028	— specific gravity of crude petroleums .....	259
— utilisation of naphthalene .....	514	( <i>See also</i> United States.)	
Acts, Petroleum .....	979	American horizontal cylindrical stills .....	479
Adipic acid from naphthalene .....	<i>br.</i> 321	— kerosene; fractions of .....	757
Admiralty storage of petroleum .....	718	— photometric tests .....	760
Aerial navigation and petroleum .....	<i>br.</i> 1752, 3157	— oil .....	87, 104
“Aerogene gas” .....	919	— industry .....	<i>br.</i> 733, 1110, 2196, 3395, 3573, 3814, 7438, 8365, 8623, 8771
Aeroplane engines .....	977	— shales .....	<i>br.</i> 506, 508
Afghanistan .....	<i>br.</i> 3627	— petroleum .....	<i>br.</i> 111, 552, 726, 729, 791, 881, 3608, 3813, 4535, 4550, 4601, 4835-4844, 4851, 4852, 4854, 4856, 4858, 4859, 5217, 5219, 5228, 5315, 6013, 6284, 6550, 6660, 6671, 6847, 6952, 6954, 7212, 7213, 7942, 8041, 8343, 8344, 8367, 8544, 8548, 8692
— distribution of petroleum in .....	212	Amiano petroleum wells, Italy .....	31
Africa, bitumen in .....	<i>br.</i> 901, 8258	Ammoniacal liquor from shale distillation .....	623
— distribution of petroleum in .....	251	Amsterdam regulations as to storage and conveyance of inflammable liquids .....	1031
— occurrences of petroleum, bitumen, etc., in.....	157	Amurland .....	<i>br.</i> 518
— petroleum in .....	<i>br.</i> 192, 901, 1891, 4735, 7369, 7370	Anesthetic; rhigolene as .....	883
Agitators for purifying petroleum .....	522	Anam; distribution of petroleum in .....	214
Agular district .....	<i>br.</i> 4373	Anapa district; petroleum deposits .....	15
Ain Zeff, Algeria; petroleum deposits .....	48	Anderson, theory of inorganic origin of petroleum .....	349
Air-gas .....	912	Anglo-Egyptian Oil Fields, Ltd. ....	51
— explosion experiments.....	708	Anglo-Persian Oil Company and Australia .....	156
— machines and carburettors.....	915	— — and New Guinea .....	156
Air-lift system of raising oil .....	446	Anglo-Russian Maximoff Company .....	<i>br.</i> 249
Aisinman, Dr., on products from Rumanian crude oils .....	569	Anglo-Saxon Petroleum Company .....	145
Alabama; distribution of petroleum and gas .....	227	Angola; petroleum in .....	<i>br.</i> 1484
— oil-fields .....	125	Aniline-toluidine oil from naphtha .....	<i>br.</i> 5740
— oil and gas .....	<i>br.</i> 1147	Animal remains; origin of petroleum from .....	557
— storage and testing regulations .....	1050	Anthracene .....	319, 537
— (general) .....	<i>br.</i> 5539	Anthracide .....	<i>br.</i> 913, 1968
Alaska; crude petroleum, specific gravity and flashing-point .....	261	Anthracite .....	642
— distribution of petroliferous deposits .....	244	— and oil strata in North America .....	353
— petroleum deposits .....	129	Anthraxolite .....	<i>br.</i> 1418
— (general) .... <i>br.</i> 1044-1046, 1587, 3416, 5110- 5115, 6281, 6282, 7418, 8794	81, 329	Anticlinical structure influence on oil .....	165, 166
Albania; bitumen mines .....	<i>br.</i> 2732	Antigua, Petroleum Acts .....	1009
Alberta; petroleum distribution .....	217	“Annapenic” burner; Rowatt's.....	892
— natural gas .....	84	Aphurdja, Kuba; crude oil from .....	<i>br.</i> 108
— petroleum .....	81	Apostalake oil-field .....	<i>br.</i> 7562
— (general) .....	<i>br.</i> 1173, 3785		
Albertainite .....	<i>br.</i> 404, 783, 1343, 1731, 2563, 3381, 3523, 5407, 5408, 5975, 6643, 6747		
Albrecht's apparatus .....	816		
Alcohol; purification by hydrocarbons .....	<i>br.</i> 7306		
Alexeef's plant for continuous distillation .....	495		
Alfreton; petroleum deposit .....	42		

	PAGE		PAGE
Appalachian field, U.S.A.; development	99	Asphalt, exports from Colombia and Cuba	1121, 1122
— hydrocarbons from petroleum	326	— from Mexico	1123
— pipe-line runs in the	1072	— from and production in Trinidad, etc.	1125
— production, value, and price of oil	1070	— felt	<i>br.</i> 6275
— pipe-lines	661	— formation	<i>br.</i> 1994, 3582, 3687, 3691, 3694, 5242, 8677
Appenzel; petroleum regulations	1047	— in France	<i>br.</i> 5896, 5897
Apscheron district, Russia; physical properties of petroleum from	287-290	— of Kerch	<i>br.</i> 4649
— oil-fields	<i>br.</i> 26, 34, 513, 515, 608, 619, 620, 2678, 2681, 2687, 2938, 2939, 2946, 2952, 3399, 4217, 4575, 4695, 7284, 7377, 7949, 8070, 8710	— lake; the "Bermudez"	144
— Peninsula; petroleum in	4, 5	— Limmer	<i>br.</i> 3436, 6631
Arabia, distribution of petroleum in	186	— manufacture	<i>br.</i> 724
Aragon, petroleum	<i>br.</i> 176	— in Mexico	<i>br.</i> 6978-6980
Aragotite	<i>br.</i> 3069	— Nenndorf	<i>br.</i> 582, 559, 3274, 4049, 4806, 5701, 6250, 6549, 6556, 6987, 6988
Arakan Islands; petroleum	65	— pavements and roads	<i>br.</i> 2078, 337, 338
Archangel Province; petroleum deposits in	<i>br.</i> 5086	— photo-chemical properties of	<i>br.</i> 1950, 3570, 7929
Archbutt, L., lubricating oil evaporation test	818	— produced and value; German Empire	1122
Argand burners; German	896	— production	<i>br.</i> 1859, 1931, 7206
Argentina; distribution of petroleum deposits	251	— in Japan	1123
— petroleum	<i>br.</i> 423, 490, 984, 2104, 3083, 3303, 4762, 5183, 5835, 5965, 6394, 6693, 6999, 7095, 7115, 8702	— in Hungary	1122
— deposits	147	— quantity and value; Italy	1123
— pipe-lines	148	— and mineral pitch; Russia	1124
— specific gravity and flashing-point of crude petroleum from	262	— refining	<i>br.</i> 2419
"Aria" lamp and burner	895	— rock	<i>br.</i> 174, 331, 880
Arizona; occurrences of petroleum in	125, 241	— in America	334
Arkansas; distribution of petroliferous deposits	234	— Californian	333
— natural gas in	126	— composition of French	334
— petroleum testing	1050	— of several descriptions	335
Armenia; bitumen and petroleum in	187	— determination of bituminous matter in	881
Armstrong, J. T.; petroleum solidification	885	— in Spain, production	1124
Arnaboldi's tester	765	— in Ross-shire	<i>br.</i> 8458
Arsenic in petroleum	303	— Russian	<i>br.</i> 2121
Artesian theory of oil-pressure	171	— Sakhalin	333
— wells in China; method of sinking	366, 371	— Sicily	<i>br.</i> 2867, 4773
Arvine's viscometer	838	— Spain, production	1124
Ash from petroleum; determination of	870	— synthetic production	<i>br.</i> 1671, 1672, 4853
Ashwick Court, Somerset; petroleum at	41	— testing	<i>br.</i> 483, 526, 916-918, 2528, 3392, 5894, 7408, 743, 880
Asia, Central	<i>br.</i> 785, 865, 7974	— Trinidad	<i>br.</i> 775, 2713, 4775, 6102, 6551, 6646, 7808, 8731
Asia Minor; petroleum deposits	<i>br.</i> 525	— in Turkey, 1901-1909, production of	1126
Asiatic Russia; distribution of petroleum in	207	— United States	<i>br.</i> 783, 1531-1534, 1670, 1990, 5584, 5977, 7432, 7963, 7964
Asphalt	<i>br.</i> 783, 835, 900, 1035-1037, 1456, 1631, 1664, 1704, 1705, 1745, 1749, 1769-1771, 1810, 1811, 1830, 1831, 1869, 1960, 2032, 2135, 2162, 2176, 2400, 2449-2452, 2494, 2797, 2813, 3300, 3301, 3437, 3552, 3555, 3688, 3692, 3694, 3798, 4019, 4102, 4162, 4163, 4173, 4175, 4227, 4228, 4434, 4580, 4613, 4757, 4804, 4811, 4982, 4998, 5000-5006, 5012, 5043, 5247, 5252, 5253, 5272, 5273, 5834, 5882, 5884, 5885, 5990, 5996, 6053, 6524, 6545, 6554, 6560, 6739, 6783, 6877, 6987, 6988, 7298, 7408, 7480, 7484, 7489, 7526, 7560, 7571, 7761, 7918, 8007, 8012, 8028, 8071, 8090, 8376, 8464, 8469, 8668	1124	
— action of chlorine on	<i>br.</i> 4742	— uses of	<i>br.</i> 724, 1287, 1702, 1703, 3236, 3735, 4674, 5054, 7019
— of nitric acid on	<i>br.</i> 2269	— Val de Travers	<i>br.</i> 690, 927, 1298, 1746-1748, 2392, 3322, 3684, 3685, 3690, 4122, 4346, 5176, 7926
— of water on	<i>br.</i> 8306	— for varnish making; testing	880
— analysis	<i>br.</i> 129, 2044, 4536, 4679, 5991, 5995, 6002, 6262, 6784, 7262, 7797	— in Venezuela	<i>br.</i> 8331
— Linton's method	818	Asphaltene	<i>br.</i> 5998
— Austria, quantity and value	1121	Asphaltic bodies	329
— Barbados, quantity and value	1121	Asphaltite	<i>br.</i> 196, 697
— Bermudez	<i>br.</i> 2275	Asphaltum, <i>see</i> Asphalt.	
— as building material	<i>br.</i> 183, 7215	Assam Oil Company	60
— California	<i>br.</i> 643, 1732, 3355-3357	— oil-fields; geological and geographical distribution	213
— Canada	<i>br.</i> 3786	— petroleum deposits	<i>br.</i> 3070, 3580, 4936, 6455, 6460, 7810
— comparison of Trinidad, Cuba, and Bermudez	332	— production	1087
— composition	<i>br.</i> 1693, 1852, 3339, 3492, 3696, 5053, 5265	— specific gravity and flashing-point of crude petroleum from	264
— of Cuba and Trinidad	331	Assaying, use of oil in	<i>br.</i> 960, 2004
— in Cuba	<i>br.</i> 394, 3065, 4442, 5356, 6624, 7617, 7831	Associated Pipe Line Co.'s line	662
— quantity of	138	Astatki, <i>see</i> Ostatki.	
— Dalmatia	<i>br.</i> 1262, 5618	Athabasca; petroleum and bitumen deposits	79, 80
— Dead Sea	<i>br.</i> 2502, 6938	Atmospheric pressure and testing oil	779
— determination of the flash-point	<i>br.</i> 4865	— — Braun's modification	793
— of the melting-point	<i>br.</i> 5051, 5738	— — use of stirrer in oil-cup	793
— distinguishing natural from coal-tar pitch	881	Atomisation of oils	<i>br.</i> 3600
— dry distillation of	<i>br.</i> 4005	Atomisers	492, 959
		Auger-rod; clay used in Canada	434
		— stem	377
		Australia; distribution of petroleum	156, 253
		— kerosene shales	<i>br.</i> 425, 699, 701, 705, 708, 709, 6160
		— oil in Northern	156
		— petroleum occurrences	<i>br.</i> 4327
		— Acts	1010
		Australian Commonwealth	1133
		Austria; asphalt production	1121
		— gas in	<i>br.</i> 3682, 4153-4159, 191, 195

	PAGE		PAGE
Austria; imports and exports of petroleum .....	1082	Barbados Petroleum Acts .....	1014
— ozokerite production and value .....	1121	— petroleum distribution .....	247
— petroleum in .... <i>br.</i> 2409, 3388, 3808, 4540	8631	— specific gravity and flashing-point of crude petroleum .....	266
— — law of 1901 .....	1012	— tar .....	140, 256
Austria-Hungary (Carpathian fields) distribution of petroleum .....	190	Barbey's Ixométre .....	839
— import duties on petroleum and products in ..	1133, 1142	Barges for kerosene .....	670, 671
— imports and exports of petroleum .....	1082	— for oil .....	<i>br.</i> 3762
— oil-fields, historical .....	19	— Thames Conservancy rules as to petroleum .....	1002
— oil and paraffin in .... <i>br.</i> 1924, 5574-5576, 7051, 7539, 7875, 7876	559	— — as to tank barge specifications .....	1005
— refining of petroleum and ozokerite in .....	559	Barnstaple oil-shale .....	<i>br.</i> 3950
Austrian Government oil refinery .....	<i>br.</i> 8454	Barrack shale .....	609
— — paraffin industry .....	<i>br.</i> 4339	Barrels for carrying petroleum .....	672
Automatic filling cock for oil .....	724	— (American oil) capacity .....	163
Automobile engines .....	975	— cleaning, glueing, and drying plant .....	721
— oils and greases .....	<i>br.</i> 1237	— filling .....	723
Automobiles .....	<i>br.</i> 4908, 5289, 7264, 7270	— lining with glue .....	721
Autoxidation .....	<i>br.</i> 1918	— for petroleum used in England .....	721
Autun; Boghead of .....	<i>br.</i> 378, 698, 707	— steel .....	723
— shales .....	<i>br.</i> 1339, 1739, 8030	Barrett oil-well jack .....	390
Auvergne .....	<i>br.</i> 277, 4522, 4533, 8003	Bartoli, A., and E. Straciaci; coefficients of expansion of petroleum fractions .....	269
Avis, J. W., see Tait, A. H. .... continuous still ..	487, 488	Bases in petroleum .....	<i>br.</i> 8593
Avonmouth Dock; petroleum regulations for discharge .....	1006	Bataafsche Petroleum Maatschappij .....	67
Azua, West Indies; occurrence of oil .....	140	Bathvillite .....	<i>br.</i> 516, 1111, 5960, 5961, 7251
BACAU oil-field; output of petroleum .....	1085	Batoum .....	746
Bacillus; the petroleum .....	<i>br.</i> 7319	Baumé and specific gravity equivalents .....	512, 529
Back pressure valve .....	402	Bavaria; petroliferous deposits .....	<i>br.</i> 2289, 2897, 2898, 2902
Bacteria; alleged in petroleum .....	<i>br.</i> 7629	— production and value of crude oil .....	1091
Baden; petroliferous deposits in .....	196	Bavarian State Railways; lubricating oil specifications .....	858
Baden State Railway; lubricating oil specifications .....	857	Beaumont oil-fields, Texas .....	<i>br.</i> 3363, 4785, 6080, 6561, 6562, 7417, 8375
Bafooi oil-field .....	<i>br.</i> 1347, 5940	Beazley, A. T.; electrical treatment of emulsified crude petroleum .....	413
Baikerite .....	<i>br.</i> 3300, 6976	Beckitt, see Clarkson .....	864
Bailers .....	377, 381	Beeswax; testing for paraffin .....	<i>br.</i> 8116
Bailing wells .....	446	Beilby, G.; Oakbank shale-oils treatment .....	634
Bailey tester .....	849	Beilstein's flash-point method and instrument .....	805
Baku boiler installation .....	444	Belfast; inflammable gas in .....	<i>br.</i> 227
— district; drilling tools used .....	439	Belgium; distribution of petroleum in .....	182
— pipe-lines .....	676	— Royal decrees as to petroleum .....	1014
— electric power for boring and pumping at, <i>br.</i> 73		Belize inflammable liquids Ordinance, 1906 .....	1015
— field; geological and geographical account, 164, 169, 204		Bell, A., see Young, W. ....	930
— geology .... <i>br.</i> 38, 118, 230, 231, 350, 511, 1691, 2318, 2684, 2691, 4555, 4556, 4650, 4652		Bene wells, Burma; crude oils .....	64
— — historical account .....	3	Benton refining process .....	579
— — number and condition of wells .....	1080	Benzene and homologues from mineral oils .....	<i>br.</i> 5625, 5741, 6826
— — production of crude oil .....	1079	— hydrocarbons in petroleum .....	308
— — yield of wells .....	443	— import duties on in various countries .....	1132 <i>et seq.</i>
— — kerosene; testing .....	559	— in petroleum .....	309
— oil industry .... <i>br.</i> 646, 810, 811, 849, 1590, 1734, 2061, 2200, 2516, 2620, 2668, 2943, 2944, 3591, 3642, 3644, 3665-3667, 3731, 4026, 4112, 4487, 4491, 4495, 4702, 5122, 5222, 5227, 5229, 5231, 5232, 5631, 5859, 5860, 6876, 6963, 7208, 7252, 7320, 7322, 7337, 7411, 7488, 7576, 7680, 7801, 7817, 7826, 7841, 8044, 8722, 8758, 8768, 8792		— in petroleum products, determination of .. <i>br.</i> 3056, 3305, 3306	538
— — wells; diameter .....	438, 439	— preparation from petroleum .....	538
— petroleum .... <i>br.</i> 390, 623, 1813, 1969, 2060, 2105, 4558, 6375, 6376		Benzin of the U.S. Pharmacopœia .....	268
— — products; yield .....	556, 557	Benzine .....	28, 315, 502, 754
— — refining plant and processes used .....	557	— American .....	<i>br.</i> 3012
— — stills used .....	558	— characters of ... <i>br.</i> 656, 657, 662, 3014, 3025	541
Balakhani field; number and condition of wells ..	1080	— explosions .....	<i>br.</i> 1957
— oil-field .....	<i>br.</i> 1579, 4194, 4196, 7249, 8074	— and fires; avoiding .....	<i>br.</i> 113
— petroleum; physical properties of .....	287	— fires .....	<i>br.</i> 3810, 6580
Balakhani-Sabuntchi oil-field; historical account ..	5, 8, 9	— fractions of .....	<i>br.</i> 5074
— yield of petroleum products .....	556	— imports and exports, Austria-Hungary .....	1082
Baltimore pipe-line .....	659	— inflammability .....	<i>br.</i> 1041, 7352
— storage and testing regulations .....	1053	— manufacture .....	<i>br.</i> 4455
Baluchistan; petroleum distribution .....	212	— from petroleum .....	502
— — deposits .....	<i>br.</i> 5749, 6244, 6455	— proportion of in various crude oils .....	284
— — production and value of crude oil .....	1087	— purification of .....	<i>br.</i> 2822, 3978
— — specific gravity and flashing-point of crude petroleum from .....	264	— in Rumania; production, consumption, and exports .....	1084, 1085, 1086
Baranga Islands; petroleum in .....	65	— rectification .....	502
Barbados bitumen .....	<i>br.</i> 1852, 2043, 2658, 6479	— Russian .....	<i>br.</i> 727, 3929
— geology of .....	<i>br.</i> 2015, 3098, 3099, 3578	— synthesis of .....	<i>br.</i> 1694
— import duties on petroleum and products in ..	1133	— testing .....	<i>br.</i> 4057, 6271, 6273
— — Manjak .....	<i>br.</i> 563, 5244	— general .....	<i>br.</i> 57, 160, 2426, 2195, 3216, 3463, 6175, 6326, 6363, 6687, 6887, 8179
— — exports .....	1121	(See also Petroleum Spirit.)	
— — naphtha .....	<i>br.</i> 7862, 8372	Benzoline lamps .....	909
		— vapour; "spontaneous" explosion .....	711
		(See also Petroleum Spirit.)	
		Berea grit oil-sand .....	<i>br.</i> 2846, 2850, 5798
		Bereczki; oil-wells near .....	25
		Berekei oil-field .....	<i>br.</i> 2679
		— — products .....	<i>br.</i> 3963

	PAGE		PAGE
Berlin police regulations as to mineral oils	1023	Boats; motor	br. 64, 1576, 1898, 5194, 5457, 5956, 6404, 6505, 7931 977
Bermuda Petroleum Act, 1887	1014	Bobrka district, Galicia; petroleum deposits; historical	20
— import duty on petroleum and products in	1133	Bog butter	43, 175
Bermudez asphalt (Venezuela)	br. 2275	Boghead of Autun	br. 378, 698, 707, 6904
— characters of at different temperatures	880	— coal	br. 2489, 2490, 2584, 2822, 5145, 6124, 6510-6512, 6514, 8383, 8384 590
— comparison with Trinidad	332	— paraffins from	328
— lake	249	Bohemia; petroliferous deposits	br. 471, 3862 194
Berne Canton, petroleum Ordinance and regulations	1048	Boiler; firing with oil-fuel	br. 940, 943, 945
Bernstein flash-point tester	803	— scale; petroleum as a preventive	br. 8405
Best burner; the W. N.	953, 954	— type used in America	376
Bibi-Eibat	br. 514, 869, 2680, 2685, 2686, 2688, 2689, 2690, 3675, 4505, 6367 164	Boilers	376, 444, 470
— field; number and conditions of wells	1080	— cleaning with petroleum	br. 3443
— historical	5, 6, 8, 9	— oil-fired	br. 692, 711, 1368, 1376, 1432, 2945, 3635, 4826, 4827, 5512, 6202, 6967, 7271, 7950, 8002, 8113, 8429, 8435, 8532, 8579
— production	1079	— used in Galicia	470
— physical properties of the petroleum	289	— used in Russia	444
— yields of petroleum products	556	Boiling-points of crude oil	280, 281, 287
Biblical references to oil	1	Boleg; mineral oils soluble in or emulsifiable with water	886
Bibliography	1155	Bolivia; import duties on petroleum and products in	1134
Biel, kerosene; fractions of	758	— occurrences of oil in	250
— of American and Russian	758	— specific gravity and flashing-point of crude petroleum from	262
Bighorn Basin, Wyoming	br. 2310, 2311	— (general)	br. 788, 3576, 6393 1134
Binagadi oil-field	br. 454, 6750	Bonaire; import duties on petroleum and products in	1134
— petroleum; properties of	br. 5526 289	“ Bonds	172
Bit; drilling	378, 434	Bone, W. A., and McCourt, C. D.; Bonecourt system of surface combustion	1318
— eccentric	452, 453	Bootjack	384
— Russian	439	Boreholes; extracting oil from	br. 7584
Bits	378	— instrument for testing inclination of	br. 1097
Bitter-almond oil; artificial	br. 8114	— temperature in	br. 4167
Bitumen (general)	br. 205, 207, 276, 282, 283, 687, 690, 702, 746, 824, 905, 947, 948, 1031, 1035-1038, 1085, 1367, 1454, 1457, 1673, 1685, 1832, 1833, 1851, 1852, 1901, 1929, 2088, 2320, 2400, 2797, 3052, 3117, 3118, 3187, 3566, 3604, 4144, 4226, 4441, 4513, 4549, 4580, 4947, 5000, 5247, 5278, 5279, 5518, 5897, 5948, 6012, 6218, 6180, 6306, 6552, 6617, 6619, 6688, 6783, 6838, 6839, 6882, 7298, 7389, 8028, 8029, 8031, 8725, 8803 1, 160, 319, 880	— water in	br. 5324
— African	br. 901	Bore waters; abnormal	br. 3255
— artificial	br. 1070	Borer; Kind's free-fall	453, 455, 457
— composition of	br. 945, 947, 1086, 2427, 3119, 3187, 3271, 4055, 4909	Boring crown for core-boring, “ Rapid ” system	458
— composition of Californian	300	— Diamond system	466
— destructive distillation of	br. 4667, 8333	— “ Express ” system	460
— determination of in asphaltum	br. 3497, 3567	— Fauc system	455, 457
— of sulphur in	872	— Fanville system	460
— geological and geographical distribution	160	— machinery (Chinese)	367
— for insulation	br. 7517	— Raky system	461
— lake of Trinidad; development of	141	— rate of progress	397
— origin of	br. 3687, 3691, 3694, 4122, 5393, 5394, 5974, 5981, 5986, 5989, 5993, 8139, 8336	(See also Drilling.)	
— for pavements, etc.	br. 3565, 3566, 3568, 6250, 7218	Borings for oil	48
— Pechelbronn	br. 946	Borneo; distribution of petroleum in	215
— salt of the Hindoos	br. 47	— petroleum in	br. 3784, 6215, 6217 70
— of sulphur mines	br. 7965	— production of petroleum	1083
— testing	br. 2357, 3965, 4431, 6555	— specific gravity and flashing-point of crude petroleum from	266
— for mixing with asphalt-rock	880	Boryslaw; geology of	br. 250, 252, 1185, 2891, 2892, 5280, 8712
— Trinidad	br. 130, 190, 1556, 1564, 6506, 6715, 6802	— ozokerite	br. 214, 391, 829, 1291, 2198, 2514, 3513-3515, 4222, 4645, 4798, 4799, 5448, 5672, 5931, 6428, 7054, 7536, 8352 22, 194
— from Trinidad and Venezuela physical characters at different temperatures	880	— petroleum in	br. 2198, 3513, 3514, 3713, 4541, 4573, 7054, 7428, 7536, 8348, 8349, 8355-8357, 8359, 8613
— varnish from	886	— Tustanowice oil-field; historical account	22
Bitumens, arsenic in	br. 1620	Bosnia and Herzegovina; distribution of oil in	189
— elastic	br. 2228, 5248, 5763	Boston, Mass.; storage regulations	1054
— solid	329	Bothwell oil-field of Canada	78
— sulphur in	br. 6003, 6004	Bothneau gas-field	br. 482
Bituminous materials; instruments for testing	br. 44	Bottoms of vessels; Board of Trade rules for carriage of oil in	689
— matter in asphalt-rock; determination of	881	Boulder, Colorado	br. 2244, 2245, 2248, 4052, 4388, 8202
— rocks	br. 291, 509, 551, 1037, 1664, 1990, 2032, 2180, 3552, 7489, 7571	Boul't's lubricant tester	851
— in Scotland	br. 193, 194	Bounties on petroleum, Canada	436
— shale, limestone, etc. in France; production of	1130	Boyd, N.; drilling a well in Polana	466
— substances, Hatchett's classification	255	Boyer, E. von; ceresin or refined ozokerite; manufacture of	565
Blaes	610	Brace, J., see Stombs, D. S.	511
Blau process of making liquefied gas	927	Bradford district, Pa. and N. Y.; oil-fields	99
“ Blatkoohl ”	642	Brady's Bend, Pennsylvania	br. 4589, 4590
Bleaching oils by fuller's earth	br. 5899	Bragni oil-field	13
“ Blown ” oils	874	Brame, J. S. S.; calorific value of Diesel engine oils	275
“ Blue ” gas	932	— specific heats and specific gravities of petroleum	279
Blundstone, E. R., see Redwood, B.	705	Brash, P., see Young, W.	613, 614

	PAGE		PAGE
Braun's flash-point tester	804	Burma; production and value of crude oil	1087
— modification of the Abel flash-point tester	793	— properties of lubricating oils	296
Brayton oil-engine	967	— specific gravity and flashing-point of crude petroleum	264
Brazil; bituminous and asphaltic deposits in	145	— yield of pit-wells in 1895	371
— substances from	br. 282, 1204, 1215	Burmese paraffin	br. 8130
— distribution of petroleum deposits	251	— petroleum	br. 2071, 6607, 6654
— geology	br. 3110	— well-diggers' wages	370
— import duties on petroleum and products in	1134	— well-sinking	369
— oil-shales in	br. 993, 7932	Burners	br. 488, 723, 1220, 2576, 2579, 5188, 5781, 7090, 7109, 7409, 7823, 7956, 8153, 8211, 8482, 8585
Bremen; laws as to mineral oils in	1025, 1026	— for liquid fuel	949
Bremerhaven; regulations of Harbour Board as to petroleum and solar oil	1027	— Best, W. N.	953, 954
Brick, burning	br. 1515	— Gordejoff	959
Brine wells in China; method of sinking	366	— Holden	949, 950, 951
Briquettes; manufacture of	br. 769, 1282, 2411	— Kermode's	954, 955, 956
Bristol Docks Committee regulations as to petroleum	1006	— Körting	957
— occurrence of petroleum near	40	— Nobel	949
British Central and East Africa Protectorate; import duties on petroleum and petroleum products	1134	— Oil City Boiler Works'	953
— Colonial Petroleum Corporation, Ltd., and Nigeria	157	— Orde	953
— Columbia; petroleum distribution	217	— Rusden-Eeles	951-953
— deposits in	80	— Russian Ostakki	951, 952
— Empire; petroleum resources	br. 2144, 3267, 3269, 3277, 5125, 5127	— Swenson	956, 957
— Guiana; occurrences of asphalt	249	— Thornycroft	958
— import duties on petroleum and products in	1134	— Urquhart's Ostakki	951, 952
— petroleum Ordinances	1015	— Walsend-Howden	960
— Honduras; dangerous goods Ordinance, 1878	1015	(See also Lamp Burners.)	
— Islands; petroleum distribution	175	— success in using	961
(See also Great Britain and United Kingdom.)		"Burning earth"	74
— laws relating to petroleum and its products	979	— fountain "	179
— New Guinea and British North Borneo; import duties on petroleum and petroleum products	1135	— water "	74
Bromination of oils	869	Burning oil; distillation test	757, 759
Bromine absorption of crude petroleum	339	— gas	932
— test of petroleum and shale products	868	— oils	br. 475, 712, 713, 1675, 2113, 3549, 3819, 4776, 5264, 5334, 7485, 7714, 8470
Brooklyn; storage and testing regulations	1055	— American	542
Brosely burning well	br. 6418	— bromine test	868
Brown-coal; ash constituents and specific gravity	645	— chemical testing	876
— composition	642, 643, 644	— French	595, 598, 599
— distillation	br. 5616, 7899-7901, 8047, 8049, 8689	— test for quality	759
— products	646	Burton-Sauer sulphur estimation method	874
— industry of Halle and neighbourhood	br. 114	Bustenari	br. 103, 265, 271, 7296
— oil	br. 816, 2743	— specific gravity of crude petroleum from	258
— estimation of solid hydrocarbons in	879	Butane	311
— properties and grouping of	643	Butanes in American petroleum	br. 4856
— tar	br. 975, 976, 1104, 1105, 1792, 2759, 2760, 3329, 3426, 3639, 4661, 4668, 4670, 5733, 6825, 6826, 6885, 7143	Butler, B. B.; lamp-black manufacture in the U.S.	939
— distillation	br. 78	Butylene; synthesis of	br. 1316
— industry	641	Butyllite	br. 4877, 6133
— oils; acid treatment of	651	Buzeu oil-field; output of petroleum	1085
— estimation of hydrocarbons in	653	Byasson; petroleum, theory of inorganic origin	349
— of Saxony; treatment of	652	CADDO FIELD, Louisiana	br. 3087, 3534
— uses of	645	Cadiz; petroliferous deposits near	47
— (general)	br. 748, 753, 1057, 2276, 2277, 2744, 2792, 3113, 3341, 3358, 3574, 3575, 5838, 6501, 6832, 8099, 8109, 8678, 8679	Cakes; paraffin	543
(See also Lignite.)		Calcium oxide in the ash from petroleum	303
Broxburn	br. 700, 7379	California asphalt	br. 3355, 3356, 4361, 5319, 5980, 5985, 5994
— oil-shales	40	— and maltha in	124
— shale retorts	br. 3257	— casing	417
Brumell; natural gas in Canada	82	— crude petroleum; specific gravities and flashing-points	260, 261
Brüner system of steam raising by liquid fuel	963, 964	— distribution of petroleum fields	405
Brunswick; petroliferous deposits	br. 921, 7480	— drilling in	405
Bryson, Jones, and Fraser; shale retort	618, 619	— oil-fields, classification of	116, 122
Buckeye Pipe Line Co.	661	— natural gas	br. 1119, 3700, 3779, 8235
Bukowina; oil-wells	24	— regions	br. 199-202, 235-237, 297-299, 300-310, 360, 362, 463, 643, 779, 955-959, 1079, 1379, 1453-1459, 1461, 1674, 1676-1680, 1991, 1993, 1995-1997, 2178, 2181-2183, 2365-2372, 2700, 3327, 3357, 3599, 3789, 3820, 4362, 4553, 5097, 5776, 5987, 6288-6294, 6518, 6519, 7119-7221, 7124, 7139, 8228-8231, 8236, 8551-8557, 8804
— petroliferous shales in	br. 8151, 8152	— petroleum	br. 111, 2242, 4839, 4841, 4846, 4858, 6291, 6292, 7120, 7121, 7123
Bulgaria; oil-shales	608	— chemical nature of	319
Bunsen; natural gas from Russia, composition of	345	— fields	121
(See Schmidt)	345	— hydrocarbons from	313
Bunte; experiments on carburetted coal gas	97	— industry; development	115
Burgos; petroleum mines in Provinces of	br. 15	— production	1066, 1067, 1068
Burma; geology of	br. 5907-5912	— pipe-line system	660
— methods of producing petroleum	369	— storage and testing regulations	1050
— oil-fields, geological and geographical description	213	— transport in	124
— petroleum deposits	br. 1500, 1501, 2294, 2441, 2838, 5594, 5644, 5645, 6455, 6607, 6653, 7496, 7497, 7531, 7671, 8311	Californian asphalt-rock	354
— production, 1912-1917	65	Caloric power; determination of	br. 815

	PAGE		PAGE
Calorific power of natural gas	343, 344	Carburettors	915
— value of liquid fuel	947	— coal-gas	917
— of petroleum products; determination of the	274, 750	— Maxim's	916, 918
— values of Texas crude oils	273	— and Sedgwick's	917
— of various kinds of petroleum	274	— Simplex	919
Calorimeters	br. 369, 687, 4965, 5895, 7246	— Weston's	916
Calorimetric bomb	279, 751	— (general)	br. 4529, 5392, 5742, 8511, 8746
Calorimetry	br. 1500, 3615, 6433, 6681, 7247	Carli, J. F.; American drilling tools	378
Calyx cutter	468	— capacity of gas strata	163
— Davis drill	466-467	— drilling operations	387
— (See Davis.)		— oil industry of Pennsylvania and New York in	
Cameron, J.; detection of fixed oils in mineral oils	875	1889	173
Campania	br. 1003, 1004	— pressure in wells	171
Camphene	890	Carniola; idrialine bitumen in	191
Campina; specific gravity of crude petroleum from	258	Carpathia	br. 2381, 3000, 3007, 3822, 5929,
— (general)	26	5934, 5935, 5937, 6478, 6689, 7107, 7549,	
Canada; asphalt	335	8669, 8698, 8700, 8709	
— burning quality tests of kerosene used in	759	Carpathian fields (Austria-Hungary)	190
— depth of oil-wells in	435	Carrington; storage and distribution of refined	
— distribution of petroleum in	217	petroleum in England	717
— geology	br. 185-187, 588-597, 1039, 1040,	Casing and casing elevator	414, 417
1063, 1064, 1066, 1067, 2007-2027, 3438,		— California	417
3439, 4752, 4753, 4779, 6592, 8310, 8538		— connecting lengths of, "Lentz" method	449
— import duties on petroleum and products in	1135	— control head	392
— Medicine Hat and Bow Island	217	— cutter	384
— methods of producing petroleum in	432	— drive-pipe	415
— minerals in	br. 1487, 1488, 3786, 4939	— inserted joint	418
— oil and gas in	br. 1477, 1489, 1494, 1725,	— oil-well	416
1726, 2194, 2280, 2537, 2538, 2806, 3366,		— perforator (Graham's)	406, 407
4833, 4836, 4845, 4945, 5025, 5635, 6417,		— spear	384
6453, 6602, 7516, 7854, 7944, 8120, 8310,		Casings used in Galicia	452
8411, 8412, 8415, 8734, 8737	1111	Casimialia field	124
— shales of	br. 507, 2770	Caspian oil region	br. 37, 395, 450, 789, 1970-1972, 6754
— Petroleum Bounty Act of 1909	1016	Caucasia; petroliferous deposits in	201
— Inspection Act of 1899	1016	Caucasian oil-fields	br. 426, 451, 604, 1632,
— and natural gas in	76	1784, 2119, 2290, 2602, 3905, 4213, 4215,	
— production and value of crude oil	1092, 1096,	4219, 4910, 5298, 5301, 5447, 6701, 6753,	
1097, 1098	554	7249, 7310, 7533, 7534, 8536	
— refining petroleum in	259	— petroleum industry	br. 2958, 2961, 2962,
— specific gravities and flashing-points of crude		4688, 4698, 5230, 6663, 6702, 6794, 6940	
petroleums of	679	— nature of	br. 578, 1818, 3955, 4612,
— storage of petroleum in	84	5057, 5058, 5066, 5081, 5298, 5302, 5939,	
— Sweetwater field	84	6311, 6391, 6965, 6966, 6993, 7294, 8059	
— total production of natural gas	1111	Caucasus; geology	br. 29, 30, 31, 32, 36, 41,
— value of natural gas production in	319	2127, 2230, 6521, 7191	
Canadian drilling system adapted for Galicia	450, 452	— ozokerite in Western	br. 134
— petroleum; chemical nature of	313	Caustic soda in petroleum refining	517
— hydrocarbons from	562	— and slaked lime	559
Candle manufacture	br. 464, 995, 1203, 1256,	Cebu; crude petroleum products from	291
1550, 2628, 3484, 3498, 4895, 5044, 6674		Celebes; petroleum at	216
— material from ozokerite	883	Cement; oil	br. 1577, 5853
— paraffin	603	— plug	412, 413
Cannel mine; natural grease in	br. 8488	— plunger	412
— coal	603	Cementing wells	408, 409, 412, 413
Caoutchouc; Australian	br. 1920	Ceramic industries; liquid fuel firing in	br. 128
— Derbyshire	br. 2228	Ceresin (Cerasin)	br. 385, 635, 977, 1082, 1108,
— mineral	br. 5405, 5536	1326, 1808, 2403, 2736, 2815, 4336-4338,	
Capacity of strata to hold gas and oil	163	4341, 4911, 5246, 7042, 7666, 8468.	
Cape Breton	br. 2330, 2615	— Austria, import duty	1133
Cape Colony; distribution of the petroleum de-		— manufacture of	565
posits in	252	— decolorising powders for	567
— occurrence of oil and gas in	158	— deacidifying powders for	567
— oil in	br. 6430	— determination of	br. 3536
— petroleum storage regulations	1016	— exports from Austria	1082
Cape Verde Islands; import duties on petroleum	1136	— Hungary, import duty	1142
and petroleum products in	293	— and paraffin wax; solubility of	330, 331
Capillary power of oil	br. 843, 946	Ceylon; import duties on petroleum and products	1136
Caracas	br. 843, 946	— petroleum Ordinances and rules	1016
Carbides, decomposition by water	349	— "Chamirak"	187
— hydrocarbons from	br. 139	Chapopote	130, 245
— origin of	br. 655	Charleston, S.C.; storage regulations	1059
Carbon burner; Curle's	954, 955	Charlottenburgh Versuchsanstalt, experiments on	
Carbon and hydrogen; direct union of	br. 892,	lubricating oils	269
6266, 6269		Chat-El-Arab basin	br. 1170
— in petroleum	299	Cheese-box still	480
— bisulphide in petroleum	302	Chelekin, see Tchelenen.	
— tetrachloride as solvent for bitumen	br. 6555	Chemical and physical properties of petroleum and	
"Cetrachloride constant" of lubricating oils	818	natural gas	255
Carbopetrocene	325	Chenhall and Chenhall; petroleum solidification	885
Carboxylic acids	322	Cherchefskey, N., refractive indices of distillates	297
— in petroleum	325	Chero valley; petroleum deposits in	35
Carbozene	325	Chesebrough Manufacturing Co.; vaseline	532
Carburetted water-gas	927	Chicago; storage regulations	1051
— processes for making	928	Chili; distribution of oil in	250
Carburetting	br. 1100, 1394, 3197, 4279, 4451,	— import duties on petroleum and products	1136
4529, 4607, 4617, 5917, 6697, 7845, 8733	915	— oil in South	152
— air	919		



	PAGE		PAGE
China; import duties on petroleum and products	1136	Colombia; distribution of petroleum deposits in	249
— methods and machinery used for producing oil	367	— import duties on petroleum and products	1136
— petroleum distribution	214	— oil in	146
— in	<i>br.</i> 5281	— petroleum and asphalt in	145
— regulations as to storage and transport of petroleum	1017	— (general) . . . . . <i>br.</i> 1229-1231, 1950, 3847-3849, 3851, 5015, 5016	
— sinking of artesian wells in	366, 367	Colorado; development of the petroleum industry	114
Chinese junk for conveying oil	682	— distribution of petroleum and gas fields	240
Chlorides, metallic	518	— oil; particulars of	115
Cholesterol . . . . . <i>br.</i> 2083, 2109, 2651, 4001, 4221, 5029, 5030, 6355, 6366, 6370, 6384, 8422		— petroleum production	1066
Cholesterol products of oil	299	— testing and storage regulations	1050
Chromometer, Wilson's; Stammer's	761	— specific gravities and flashing-points of crude petroleum	261
Chronothermometer . . . . . <i>br.</i> 6447		— (general) . . . . . <i>br.</i> 2046, 2047, 2244-2246, 2248, 2312, 2503, 2504, 4357, 4359, 4360, 4364, 4366, 4367, 4369, 4371, 4372, 4374-4377, 4379, 4387, 4388, 4527, 5590, 5592, 7432, 7528	
Chrysene and derivatives . . . . . <i>br.</i> 78, 4471	319	Colloidal earths, use of	526
Cincinnati; storage regulations	1057	Colour of lubricating oils; determination of the	813
Clack-valve for storage tanks	678	— of petroleum; Bremen exchange tests	1026
Clarkson and Beckitt; hydraulic press for paraffin testing	864	— determination of	761
Clay; affinity for petroleum	173	Columbia, Dist. of (U.S.A.); specific gravity and flashing-point of crude petroleum from	262
— auger-rod used in Canada	434	— storage and testing regulations	1051
Clermont-Ferrand, France; petroleum deposits	47	Colza; mineral	742
Clinton limestone; natural gas from	108	— "Combustible earth"	200
— sands . . . . . <i>br.</i> 969		Combustion; Bonecourt system of surface	1318
Climate and flashing-point	777	— Prof. J. S. S. Brame on	961
Cleaning tank vessels	694	Comero Is.; import duties on petroleum and products	1137
Coal; aschengrund	643	Commercial products of crude petroleum	284
— azabache	643	Comparison of lamps and oils	898
— black amber	643	— of oil-lamps and gas	897
— Boghead or Torbanehill mineral	590	Compound oils	874
— briquettes; use of petroleum in making . . . <i>br.</i> 6718		Compressing engines for use with gas-wells	430
— brown	642	Compression of gas from shale distillation	623
— camel	603	Concrete; oil. . . . . <i>br.</i> 1577, 5853	
— Cologne	643	— tank steamer	688
— composition	644	Condensation; fractional . . . . . <i>br.</i> 8191	
— distillation; early patents for producing oil by	42	— of vapours from shale distillation	622
— dysodil	643	Condensers	509
— field of Shropshire . . . . . <i>br.</i> 85		— box	509
— fire	643	— naphtha	502
— foliated shale	643	— parallel-tube	509
— gagat . . . . . 643, 649		— worm	509
— gas; carbureting with vaporised hydrocarbons	915	Conglomerates as reservoir-rocks	161
— gas carburetor; Maxim and Sedgewick's	917	Congo; import duties on petroleum products	1139
— enriching	932	Conil, Spain; petroleum at	47
— illuminating value	927	Connecticut . . . . . <i>br.</i> 6020, 6021	
— and oil gas; properties of mixtures of	931	— distribution of petroliferous deposits in	223
— gloss	643	— testing and storage regulations	1051
— grease	643	Consumption of oil and illuminating power	897
— jet	643	Continuous distillation process	484, 507, 511
— lamp-black	643	Contract for drilling	395
— leaf	643	Converters; use of crude oil in . . . . . <i>br.</i> 6724	
— manufacture of oil from, in the U.S.	87	Cooling apparatus for producing paraffin	632-635
— moor	643	Cooper, H. P.; bituminous matter in asphalt-rock, extraction of	881
— and oil	942	Cooper, see Wanklyn	507
— oils . . . . . <i>br.</i> 261, 952		Coorongite . . . . . <i>br.</i> 899, 1565, 3700	155
— explosibility of . . . . . <i>br.</i> 171		Copper oxide in ash of petroleum	303
— paper	643	<i>Coquimbo</i> ; explosion on steamer	697
— paraffin	643	Cosmolene . . . . . <i>br.</i> 4544, 4849, 5304, 5305	
— paraffins from Boghead	328	— "Cosmos" burner	896
— pitch or specular	643	Costa Rica; import duties on petroleum and products	1137
— reed	643	— oil in	152
— slate	643	Cotter pin	457
— stem or columnar	644	Cracked spirit, chemical nature	578
— stinking	643	— and diolefines	306
— Sudbury . . . . . <i>br.</i> 2006		Crackene	325
— theories of origin of petroleum from	349	Cracking	577, 578
Coalinga field, California	124	— mechanism of	578
Coalport; petroleum of	40	— process . . . . . <i>br.</i> 4235, 5973	477-479
Cobridge, Staffs; refinery at	40	— Hall's	584
<i>Cockatrice</i> ; explosion on H.M.S.	697	— Rittman's	582
Cockrell viscometer	840	— still	478
Cockshead seam, Staffs; oil in the . . . . . <i>br.</i> 3046		"Cracking" distillation of oil . . . . . 477, 518, 519, 577, 613	
Coefficient of expansion; effect of instrumental errors in determination of	270	Cresecut pipe-line (U.S.)	659
— of petroleum	268-269	Crimesa; petroleum deposits . . . . . <i>br.</i> 256, 257, 6230, 6231	201
— and specific gravity; relation between	268, 269	— in; historical	15
<i>Cœur</i> ; petroleum deposits at	47	— physical properties of petroleum	290
Coke; percentage yielded by various crude oils	284-286	Croatia; oily marshes in	191
— by petroleum . . . . . <i>br.</i> 1793, 4430, 4648, 4654, 6287		Crude oil, see Petroleum.	
— determination of in petroleum residuum	867	— shale-oil examination	877
Cokings	546		
Cold; production of . . . . . <i>br.</i> 2159			
Cold-test of lubricating oils	853		
— apparatus for testing	855		
Cole, J.; distilling process	490		
Colombia; asphalt production	1121		

	PAGE		PAGE	
Cuba; asphalt in . . . . .	br. 394, 3065, 4442, 5359, 624, 6823, 7617, 7831, 7962, 8257			
— composition of . . . . .	331, 332	Desulphurising . . . . .	br. 4803	
— exports . . . . .	1122	— mineral oils; Adiasewich's process . . . . .	525	
— and petroleum deposits . . . . .	138	Detergent; use of petrol as . . . . .	886	
— distribution of petroleum deposits in . . . . .	246	Dettmar's oil tester . . . . .	br. 4706	
— import duties on petroleum and products . . . . .	1137	Devoll's "water safety-lamp" . . . . .	902	
— mineral deposits . . . . .	br. 777, 1050, 1154, 1349, 2258, 4443, 5609	Dewar and Redwood; distillation process and apparatus . . . . .	579	
— naphtha in . . . . .	br. 6559, 7421, 7422	Diabuntite . . . . .	br. 3165	
Cumene and pseudocumene in petroleum . . . . .	315	Diamond boring system . . . . .	466	
Cumarone . . . . .	654	Diaphragm system of combustion . . . . .	1318	
Curle's carbogen burner . . . . .	954	Diesel oil-engines . . . . .	br. 175, 908, 1362, 1626, 1650, 1763-1768, 1816, 2314, 2880, 3039, 4038, 4312, 4316, 5257-5259, 5317, 5318, 5730, 6590, 6977, 6989, 7505 . . . . .	967, 972, 973 973, 974
Curly shale . . . . .	610	— semi-; oil-engine . . . . .	973, 974	
Customs duties on petroleum and its products in various countries . . . . .	1132-1151	Digboi, Assam; oil-wells at . . . . .	60	
Cycloheptanes . . . . .	br. 5075	Digging tool; Burmese . . . . .	369	
Cyclohexanes . . . . .	br. 5069	Di-isopropyl in Baku benzine . . . . .	br. 319	
Cyclohydrocarbons . . . . .	308	Dilatometer for determining coefficient of ex- pansion . . . . .	271, 272	
Cycloparaffins . . . . .	307, 513	Diolefines . . . . .	305, 306	
Cyclopentanes . . . . .	br. 5067	— and "cracked spirit" odour . . . . .	306	
Cylinder oil for Palatinat Railway; specification for . . . . .	859	Dirt in paraffin; determination of . . . . .	864	
— oils; valuation of . . . . .	br. 6567	— in tank . . . . .	717	
Cymogene; American . . . . .	541	Disinfecting power of petroleum . . . . .	br. 1690	
Cyprus; import duties on petroleum and products . . . . .	1137	Distillate (white spirit) testing . . . . .	741, 755	
— Petroleum Acts, 1883 and 1892 . . . . .	1017	Distillates; amount at various temperatures . . . . .	281, 282, 283, 284	
DAGHESTAN oil-fields; historical . . . . .	11	Distillation . . . . .	476	
— Territory. br. 18, 452, 453, 618, 2676, 7188, 7368 . . . . .	203	— continuous . . . . .	br. 102 . . . . . 484, 511, 558, 625	
— petroliferous deposits . . . . .	203	— at Baku by Nobel Bros. . . . .	558	
Daimler motor engine . . . . .	977	— "cracking" system of . . . . .	478	
Dakota; natural gas in North and South . . . . .	127	— dry . . . . .	br. 6483	
— occurrences of oil and gas in North and South Dakota, Persia; petroleum deposits . . . . .	238 52	— Engler's system of . . . . .	748	
Dalmatic asphalt . . . . .	br. 1262, 5618, 6991	— fractional . . . . .	br. 7719, 7758, 7928, 8180, 8181, 8184, 8546, 8601	
— asphalt-limestone in . . . . .	190	— of Galician crude oil; fractional . . . . .	282	
Dalton, L. V.; inorganic origin of petroleum; summary of arguments . . . . .	350	— of mineral oils . . . . .	br. 624, 625, 923, 2472, 2479, 2519, 2530, 2761, 2762, 2855, 2921, 3369, 3701, 3811, 3945, 4015, 4020, 4340, 4532, 4606, 5191, 5225, 5314, 5823, 5827, 5831, 5973, 6189, 6337, 6409, 6425, 6685, 6686, 6869, 6998, 7453, 7561, 7877, 8101, 8327, 8346, 8442, 8578, 8607	
— petroleum; theories of formation from marine organisms . . . . .	359	— of petroleum at Baku . . . . .	557	
Dambovitzka oil-field; output of petroleum . . . . .	1085	— results of fractional . . . . .	280	
Dam shale . . . . .	609	— steam . . . . .	br. 2979, 2980	
Danish flash-point tester . . . . .	767	— test for burning oil . . . . .	757	
Dardanelles . . . . .	br. 2112	— for crude petroleum; fractional . . . . .	746	
Davis-Calyx drill . . . . .	466	— use of steam in . . . . .	478	
Davson's system of petroleum field organisation . . . . .	474	— vacuum . . . . .	507	
Day, D. T.; duration of petroleum supply . . . . .	942	Distilling apparatus; Galician . . . . .	559	
— petroleum, theories of formation from marine organisms . . . . .	363	— plant used in the U.S. . . . .	539	
Dead Sea . . . . .	br. 4438, 4440, 5332, 7832	— Regnault's . . . . .	750	
Decane . . . . .	278, 304	— various forms . . . . .	750	
— oil-gas yielded by . . . . .	926	— shale-oil . . . . .	625	
— specific heat of . . . . .	277	— shale; retorts for:—		
Decolorising agents . . . . .	br. 4739, 8583	Bryson and others . . . . .	618	
— petroleum products by fuller's earth . . . . .	526	continuous . . . . .	611	
— powders for ceresin . . . . .	568	Henderson . . . . .	615, 617, 621, 622, 623, 624, 625, 626, 629, 630, 631	
"Defries" lamp; Sepulchre's . . . . .	892	Pentland . . . . .	615, 616	
Dehne filter-press for ozokerite . . . . .	562, 563	in Scotland . . . . .	611	
Delano, W. H.; asphalt . . . . .	335	Russian system . . . . .	481	
Delaware; testing and storage regulations . . . . .	1051	Young and Brash . . . . .	614	
Denmark; distribution of petroleum in . . . . .	199	Young and Fyfe . . . . .	618-621	
— import duties on petroleum and products . . . . .	1137	Distribution of kerosene in the U.S. . . . .	670	
— natural gas in . . . . .	br. 7921	— of petroleum, general . . . . .	655	
— regulations as to storage, sale, and transport of inflammable liquids . . . . .	1017	— in United Kingdom . . . . .	715	
Demulsification; Phillip's tester . . . . .	856	Docosane . . . . .	313	
"Demulsification value" of turbine lubricating oils . . . . .	855	Dodecane . . . . .	311	
Dennis well, Bradford, Pa.; drilling record . . . . .	391	Dolomite as a reservoir-rock . . . . .	162	
Denver; storage and testing regulations . . . . .	1050	Dominica; occurrence of oil in . . . . .	139	
Deplegmators . . . . .	br. 625, 3307, 481, 482, 747	— Petroleum Act, 1874 . . . . .	1018	
— for use in fractionating petroleum . . . . .	747	— and Dominican Republic; import duties on petroleum and products . . . . .	1138	
Deprez and Napoli; lubricant tester . . . . .	848	Donkin, B.; requirements of an oil-engine . . . . .	966	
Depth of American oil-wells . . . . .	392, 394, 395	Doolittle viscometer . . . . .	841	
— of wells . . . . .	84, 442	Dopplerte . . . . .	br. 136, 259, 1349, 1462, 1718, 2464, 2896, 3038, 3866, 3888, 4634, 5169, 5422, 8276	
— Russian . . . . .	442	Dorsetshire bituminous shales . . . . .	br. 8380, 8381	
Derbyshire . . . . .	br. 745, 2811, 4715, 5092, 5162, 5248, 7420	— shale; yield of volatile matter from . . . . .	697	
Derrick as used in America . . . . .	376	Doterel; explosion on H.M.S. . . . .	601	
— in Canada . . . . .	432, 433	Dotricontane . . . . .	327	
— Raky . . . . .	461, 462	Dow penetration test . . . . .	880	
— for rotary drilling system . . . . .	398, 399	Down Holland Moss . . . . .	br. 744, 748	
— steel oil . . . . .	br. 8491			
Destructive distillation, <i>see under</i> Distillation.				
Desulphurisation . . . . .	514			
— Frasch process . . . . .	515, 516, 517			

Down Holland; petroleum at . . . . . 40  
 Draught; Wallsend-Howden system for . . . . . 960  
 Drill; the Davis-Calyx . . . . . 466  
 Drilling, Bounties on Canadian oil . . . . . 436  
 — cable system . . . . . 435  
 — in California . . . . . 405  
 — Canadian, adopted for Galicia . . . . . 450  
 — circulating system . . . . . 404  
 — combination system . . . . . 404  
 — contract . . . . . 395  
 — deep in Galicia . . . . . 468  
 — Diamond system of . . . . . 466  
 — "Express" system of . . . . . 460  
 — Fauck's free-fall system of . . . . . 455  
 — Fauvelle system . . . . . 460, 473  
 — Galician hand system . . . . . 448  
 — hand . . . . . 448  
 — Kind's free-fall borer . . . . . 453  
 — machines; portable . . . . . 404  
 — methods . . . . . 449, 458  
 — in Galicia . . . . . 449  
 — operations; American . . . . . 384  
 — output; Pennsylvania . . . . . 379  
 — plant . . . . . 454  
 — American . . . . . 375  
 — portable machines . . . . . 404  
 — "Rapid" system of . . . . . 458  
 — record of Dennis well, Bradford, Pa. . . . . 391  
 — of the Lucas well, Texas . . . . . 403  
 — Rotary system . . . . . 397, 459, 440  
 — system in Pennsylvania, evolution of the present . . . . . 393  
 — Raky . . . . . 461  
 — tools; American . . . . . 377  
 — Chinese . . . . . 368  
 — dimensions and weight of American . . . . . 379  
 — used in Russia . . . . . 439  
 — wells; Canadian method . . . . . 432  
 — in Russia; methods of . . . . . 439  
 — (general) . . . . . br. 734, 962, 972, 992, 1188, 1265, 1437, 1465, 1687-1689, 1706, 1925, 1974, 2123, 2124, 2154, 2173, 2174, 2203, 2208-2211, 2215, 2218, 2219, 2221, 2226, 2227, 2252, 2316, 2486, 2487, 2499, 2557-2559, 2580, 2650, 2734, 3042, 3045, 3242, 3259, 3340, 3405, 3414, 3662, 4500, 5254-5299, 5300, 5554, 5736, 5759, 6039-6043, 6146, 6199, 6200, 6531, 6579, 6581, 6655, 6656, 6658, 6659, 6662, 6752, 6807, 6889, 6943, 6945, 7047, 7058, 7059, 7178, 7248, 7254-7257, 7266, 7267, 7339, 7348-7351, 7504, 7524, 7588, 7631, 7633, 7769-7771, 7916, 7917, 7949, 7951, 8157, 8170, 8232, 8427, 8428, 8432, 8473, 8474, 8534  
 (See also Boring.)  
 "Drips" for excluding water or oil from gas mains . . . . . 431  
 Drive-pipes; sinking . . . . . 387, 415, 434  
 Drohobycz . . . . . br. 214, 2890  
 Droobja fountain . . . . . 8  
 Dry cleaners; using mineral spirit; licensed in London . . . . . 886, 991  
 Duckham, A.; carbonisation test of lubricating oils . . . . . 818  
 Duddington shale mines . . . . . br. 7234  
 Duluth; storage regulations . . . . . 1054  
 Dunnet shale . . . . . 609  
 "Duplex" burner; Hinks . . . . . 890-892  
 Dupré; explosive mixtures of petroleum vapour and air . . . . . 702-704  
 Durand-Claye; distinguishing between natural asphalt and coal-tar pitch . . . . . 881  
 — asphalt-locks; composition of . . . . . 334  
 Duske lubricant tester . . . . . 847  
 Dust laying by "soluble oil" . . . . . 886  
 — prevention . . . . . br. 3562-3566, 3799  
 Dutch East Indies; petroleum production in the . . . . . 67  
 — — and Dutch Guiana; import duties on petroleum and products . . . . . 1138  
 — Indies . . . . . br. 812, 944, 1384, 2149-2153, 4764, 4765, 6341, 7442, 8338  
 Dutton oil-field, Canada . . . . . 79  
 Dyes from petroleum . . . . . br. 3970, 3987, 5134  
 Dysart, Fife; bitumen at . . . . . 39  
 Dysodil . . . . . br. 818, 1343, 1962, 4356, 6403, 6650, 7372 . . . . . 642  
 EAMES process of oil-firing for furnaces . . . . . 444

Earth-balsam . . . . . PAGE 1, 19  
 Earthquakes and effect on oil-wells . . . . . 87  
 Earths; use of colloidal . . . . . 526  
 Eastern Archipelago; distribution of petroleum in . . . . . 215  
 — petroleum in . . . . . 67  
 Echigo, Japan; oil-fields of . . . . . br. 372, 3641 . . . . . 75  
 Ecuador crude petroleum; specific gravity and flashing-point of . . . . . 262  
 — distribution of the oil deposits in . . . . . 250  
 — import duties on petroleum products . . . . . 1138  
 — petroleum fields of . . . . . 146  
 Effect on oil of solid masses . . . . . 272  
 Egypt; crude oil production . . . . . 51  
 — petroleum products from . . . . . 291  
 — distribution of petroleum in . . . . . 185  
 — import duties on petroleum products . . . . . 1138  
 — petroleum deposits in . . . . . br. 478, 760, 787, 1171, 1293, 1917, 3006, 3656, 3853, 4774, 7040, 8259 . . . . . 49, 50  
 Ehrenberg flash-point tester . . . . . 804  
 Elaterite . . . . . br. 136, 4715, 4963, 5410 . . . . . 39, 329  
 Elastic bitumen . . . . . 155  
 Eldridge, G.; tank steamers . . . . . 684  
 Electric flash-point testers; Engler's . . . . . 794, 795  
 — Heumann's . . . . . 796  
 — Lethby's . . . . . 794  
 — Pease's . . . . . 794  
 — Saybolt's . . . . . 767  
 — power for pumping and boring at Baku . . . . . br. 73  
 — work; use of asphalt and bitumen in . . . . . br. 7788  
 Electrical treatment of emulsified crude oil . . . . . 413  
 Electricity in oil-works; use of . . . . . br. 938, 4171  
 Elizabethpol; petroleum deposits in the province of . . . . . 16, 204  
 Elevators . . . . . 414  
 Elliot, A. H.; flash-point, comparison of systems for testing . . . . . 809  
 — test and apparatus . . . . . 798  
 Elsass bitumen . . . . . br. 1685, 2231, 5295, 7293  
 — geology . . . . . br. 218-220, 367, 602, 3730  
 — oil-fields of . . . . . 43-46  
 — petroleum . . . . . br. 814, 2751, 2854, 2949, 3728, 3729, 4330, 5465, 6136, 6372, 7988, 8284, 8285, 8289, 8765  
 — products . . . . . 571  
 — petroliferous deposits in . . . . . 195  
 — production and value of crude oil in . . . . . 1091  
 (See also Alsace.)  
 Elsass-Lothringen State Railways; lubricating oil specifications . . . . . 860  
 Emilian district, Italy; petroleum deposits in . . . . . 31, 33, 35  
 Emulsified crude petroleum . . . . . 413  
 Endecane . . . . . 311  
 "Enfleurance" . . . . . 562  
 Engine; Brayton . . . . . 967  
 — Diesel . . . . . 965, 967, 972  
 — Hoek . . . . . 967  
 — Hornsby-Akroyd . . . . . 970, 971  
 — Otto . . . . . 965  
 — Priestman . . . . . 967, 968, 969  
 — Tangye . . . . . 972  
 — Trusty . . . . . 971  
 — Warwick . . . . . 966  
 — "Zephyr" launch . . . . . 977  
 Engines; classification of oil- . . . . . 966  
 — consumption tests of oil . . . . . 972  
 — Daimler . . . . . 977  
 — Diesel . . . . . 973  
 — of flying machines . . . . . 977  
 — gas and oil . . . . . br. 432, 541, 722, 1123, 1134, 1226, 1227, 1389, 1391, 1393, 1559, 1813, 2158, 2666, 2667, 2868, 3093, 3288, 3380, 3872, 4525, 4787, 4789, 4791, 4902, 5083, 5165, 5166, 5257-5259, 5307, 5339, 5340, 5411, 5513, 6025, 6614-6616, 6673, 6813, 6841, 7047, 7077, 7155, 7177, 7373, 7457, 7483, 7507, 7724, 7763, 7786, 7787, 7805, 8150, 8213, 8298, 8406, 8789  
 — internal combustion . . . . . br. 169, 373, 908, 1022, 1153, 1255, 1390, 1392, 1903, 2140, 3526, 3529, 3530, 3699, 4736, 5143, 6473, 6616, 7806  
 — — for motor cars . . . . . 977  
 — — for road work . . . . . 974  
 — — for vessels . . . . . 975  
 — marine . . . . . br. 169, 738, 1559, 1713, 3555, 4524, 5213, 5317, 5318, 5886, 7506, 7723, 7724, 7763, 8281

	PAGE		PAGE
Engines; oil-well	377	Filling oil-barrels	723
— of motor-cars and motor-boats	975-977	Filter-presses for use in ozokerite manufacture	563
— Mercédes	977	Filtering media	518
— Petter	974, 975	Findlay gas- and oil-field, Ohio	107
— petroleum	965, 966	Finkener; test for rosin oil in mineral oil	876
— used in Russian oil-fields	445	Finland; import duties on petroleum products	1139
England; distribution of petroleum in	176	— petroliferous deposits	200
— petroleum deposits, historical	38	Fire; danger of	419
— specific gravity and flashing-point of crude petroleum	265	— engines; automobile	br. 7270
(See also Great Britain and United Kingdom.)		— extinction by foamite	713
Engler, C.; animal origin of petroleum	357	— test of lubricating oils	814
— coefficients of expansion of crude petroleum	263	— of mineral oils	763
— composition of natural gas from Pechelbrom	346	— testers; Ingram and Stapper	851
— electric flash-point tester	794	— MacNaught	847
— fractionating apparatus for German residues	576	— Thurston	849, 851
— flask and process	748	— Woodbury	847
— kerosene; Russian tests for refined	757	"Fire-wells"	72
— petroleum from organic matter; formation of	360	Fires; mineral oil	br. 113, 120, 357, 3668, 8339, 8632
— refractive indices of petroleum distillates	292	Firing benches with crude oil	br. 62
— viscometer	826, 827, 832	"Firing head"	427
— yield of Baku petroleum products	556	Firing with liquid fuel	br. 364, 1246, 1286, 2639, 3226, 4615, 5474, 5844, 6105, 6202, 6248, 6900, 7354, 7635, 8024, 8089, 8113, 8299
— and Böhm; vaseline, preparation and properties of	532	— with oil-fuel; losses in, and their elimination	946
— and Kunkler; viscometer	832	Fish; effect of petroleum oils on	br. 4118, 4873, 5622
— see Parrish.	801	Fish-tail bit	400
Enniskillen; oil-wells of	br. 2329	Fishing tools; American	381-386, 435
Erie County, Pennsylvania	br. 756	— Chinese	369
Erroneous estimates of oil-fields capacity	163	— used in Canada	435
Erythra; import duties on petroleum and products	1138	Fissures; oil in	br. 7230-7232, 7634
Etard's reagent	341	Flames	br. 7230-7232, 7634
Estonia; petroliferous deposits	200	Flannery, Sir F.; tank steamers for Suez Canal traffic	692
Eternal fire	187	— see Terry, S. H.	695
Ethane	311	Flashing-point; barometric correction,	777, 779, 780, 784, 788, 789
Ethiopia; import duties on petroleum products	1138	— Bremen petroleum exchange regulations	1026
Ethylene; effect of heat on	br. 1651, 4623	— of Canadian petroleum	259
— estimation of	br. 2999	— climatic correction	777, 778
— illuminating power of	br. 2414	— comparison of systems for testing	809
— in petroleum	315	— determination of	763
Ethylenes	305	— in lubricating oils	br. 94
Ethylenic hydrocarbons in petroleum	314, 315	— early legislation as to	764
Etna eruptions	br. 7126-7138	— legislation in India	779
Euosmite	br. 2898	— raised by "spraying"	559
Eupion	br. 6486, 6488, 6494, 8036	— Scottish method for testing for heavy mineral oil	864
Eureka Pipe Line Co.'s lines	661	— table of standard and methods in different countries	1061
Europe; transport of oil in	716	— of various crude petroleum	259, 261, 266
Evaporative values of coal and oil	br. 8347, 8795	— testers: Abel's	767 <i>et seq.</i>
Exhaust gases from motors	br. 3531	— Abel-Pensky	785 <i>et seq.</i>
Experiments in explosions	703	— Arnaboldi's	765
Explosion of benzoline vapour; spontaneous	711	— Beilstein's	804, 805
Explosions; accidental	br. 8, 10, 696, 702	— Bernstein's	803
— due to ignition of petroleum vapour	br. 890, 1388, 1395, 5243, 5597, 7592	— Braun's	804
Explosive mixtures of petroleum vapour and air, formation of	702	— Danish	767
"Express" drilling system	460	— Ehrenberg's	804
Extinguishers for lamps	901-903	— Elliott's	798
Extracting; use of light petroleum for	br. 5091	— Engler's	794, 795, 801
Extractors for use in ozokerite manufacture; Merz	565, 566	— Foster's	802
— Thorn	563	— Gawalowski's	806
— Wegelin-Hübner	564	— Granier's	800
FAIRBANK, J. H.; Canadian petroleum fields	78	— Gray's	816
Fairmont gas-well, Indiana	108, 109	— Haass's	796
Farsan Islands; petroleum in	51	— Heumann's	796
Fats; decomposition by heat	br. 2065, 2102, 2107, 3852, 5046	— Indiana State	766
Fatty oils; determination of mineral oils in	br. 2292, 2565, 2582, 3452, 4812, 5032, 5041	— Keates's	767
— detection in mineral oils	br. 6735, 7023	— Letheby's	794
Fauck's free-fall boring system	455-458	— Liebermann's	805
— under-reamer	456	— Luchaire's	801
— water-flush	461, 462	— Mann's	805, 806
Fauvelle system of drilling	460	— V. Meyer's	796
Fels shale	609	— Millsbaugh's	805
Fergana Province; petroleum deposits	br. 823, 3944, 3949	— Parrish's	801
Fergusons; explosion on s.s.	680, 699	— Parrish-Engler	801
Fichtelite	br. 442, 443, 836, 912, 1042: 1364-1366, 3231, 6162, 6916, 6918, 6930, 7018, 7291	— Pease's	794, 795
Fifeshire; geology	br. 2561, 2562	— Pensky and Pensky-Martens	814, 815
Fiji; import duties on petroleum and products	1139	— Phlog-elalo-mètre	802
— Kerosene Act and Customs Ordinances	1018	— Rosenblatt's	808
Filemonowicz, see Pawlewski	879	— Salleron-Urbain	806, 807
Filling cock; automatic, for oil-barrels	724	— Saybolt's	765
		— Squire's	764
		— Stoddard's	805
		— Tagliabue's closed	797
		— open	763

	PAGE		PAGE
Flashing-point testers; Treuman's .....	817	Fuel oil .. br. 167, 222, 1089, 1227, 1595, 1862,	
— Vette's .....	806	1977, 2852, 3103, 3104, 3106, 3535, 4523,	
— Wisconsin State .....	798	4781, 4788, 6469, 6722. 743, 860	
— (general) .....		— oil; calorific value .....	750
br. 583, 1000, 1096, 1905, 1914,		— determination of calorific value .....	750
2807, 3294, 3451, 3474, 3480, 3490, 3628,		— consumption on U.S. railways .....	1079
4662, 4663, 5034, 5104-5107, 5109, 5149,		— specification of U.S. Government .....	860
5170, 6678, 7092, 7380-7382, 7413, 7450-		— testing .....	744
7452, 7714, 8193, 8264, 8786	763	— oils in Canadian refineries; production of .....	1092
Florence oil-field, Colorado .. br. 1986, 2246, 4389	115	— specific gravities and specific heats of various	279
Florida fuller's earth .....	527	— patent .. br. 769	
— petroliferous deposits in .....	227	— petroleum as .....	940
Florida .....	br. 616	— testing the heating value of .. br. 2645,	
Flow of oil; inducing .....	420	2646, 3646, 3647, 6195, 6421	
— of wells; controlling in Russia .....	443	— specifications .....	940, 941
Fluidimeter; Phillips's .....	819	Fuller's earth and its use in purifying petroleum	
Fluidity of lubricating oils .....	269	products .. br. 2754, 5899	526
Fluorene .....	319	Furbero pipe-line, Mexico .....	673
Fluorescence in oil testing .. br. 5843	72, 310	Furnaces; oil-firing for .. br. 159, 181, 713,	
Flying-machine engines .....	977	1012, 1148, 1149, 1177, 1430, 1529, 2004,	
Foamite for fire extinction .....	713	2272, 2830, 2951, 4517, 4556, 5632, 5906,	
Forens asphalt-rock; composition .....	334	6205, 6412, 6853, 7090, 7508, 7908, 8300,	
Forges; use of oil as fuel .. br. 2143, 4554, 6202		8525, 8673. 943, 963	
Formolite reaction in petroleum .....	340	Fye, J., see Young, W. ....	618
Formosa; petroleum deposit in .. br. 1214	76	GABIAN; petroleum of .. br. 933, 5513, 6601,	
— production of crude petroleum in .....	1089	8691	
Forsunkas .....	492	Gagat; Bentheim .....	643
Fossil grease .. br. 4040		Galicia; boilers used in .....	470
Fossils .. br. 80, 125, 298, 299, 302, 509, 693,		— crude petroleum; specific gravities .....	263
710, 915, 3220, 3867, 4092, 4548, 6075,		— deep drilling in .....	468
8052, 8054, 8058	40	— methods of producing petroleum .....	448
Foster automatic flash-point tester .....	802	— ozokerite industry of .. br. 214, 829, 978, 2953,	
Foundry furnaces; gas- and oil-fired .. br. 131,		3244, 3512	
6853, 6854		— oil-field of .....	20, 192
Fountain well, U.S.A. ....	88	— production of crude petroleum .....	1081
Fountains .. br. 6130	7, 12, 445	— pumping in .....	463
Fractional distillation test for crude petroleum ..	280, 746	— (general) .. br. 178-180, 246, 358, 391, 484,	
Fractionating apparatus for German residues ..	576	497, 500, 502, 770, 848, 972, 1060, 1185,	
— flask; Engler .....	748	1273, 1387, 1502, 1921, 2000, 2164, 2196-	
— Regnault .....	750	2200, 2204, 2217, 2922, 2256, 2243, 2619,	
Fractionation; cold .. br. 3958, 3972, 5525,		2622, 2736, 2890, 3128, 3210, 3244, 3328,	
8617, 8620		3385, 3400, 3449, 4099, 4100, 4266, 4267,	
France; bituminous shale, limestone, etc., pro-	1130	4309, 4760, 5117, 5560, 5566, 5567, 5617,	
duced in .. br. 312, 689-691, 1329, 1772, 4534		5666-5690, 5765, 5767, 5769, 5874, 5943,	
— composition of asphalt-rock from .....	334	5944, 6327, 6331, 6534, 6401, 6461, 6845,	
— decrees as to petroleum .....	1019	6894, 6898, 6925, 6926, 7490, 7491, 7536,	
— distribution of petroleum .....	178	7577, 7540, 7544-7548, 7552, 7553, 7744-	
— early legislation as to flash-points .....	764	7746, 7752-7754, 8154, 8156, 8167, 8172,	
— import duties on petroleum products .....	1139	8296, 8424-8427, 8604, 8606, 8610, 8612,	
— natural gas in .. br. 3583	181	8655, 8693, 8701, 8706, 8709, 8713, 8714	
— oil-wells .. br. 1865		Galician crude petroleum; fractional distillation of	
— petroleum deposits .....	43	— distilling apparatus .....	560
— refining .....	576	— ozokerite industry; historical .....	23
— shale-oil industry .. br. 3237	598	— petroleum; deliveries of to refineries, 1907-	
Fraser, see Bryson .....	618	1910 .....	1083
French Colonies; import duties on petroleum and		— industry; historical .....	19
products .....	1139	— products .....	560
— lubricant tester .....	850	— vaseline oils .....	532
Freseun, vaseline; action of oxygen on .. 536, 537		— vaselines, composition of .....	533
Friction in fluids .. 842, 843		Galician-Canadian drilling plant .....	450
— testers for lubricating oils; Bailey .....	849	Galveston; storage regulations .....	1060
— Boulton .....	851	Gambia; import duties on petroleum products ..	1140
— Duprez and Napoli .....	848	— Petroleum Ordinance, 1905 .....	1023
— Duske .....	847	Gas; air .....	915
— French .....	850	— air-machines .....	915
— French-Staffer .....	851	— analysis .. br. 648, 660, 2739, 2823, 3959,	
— Ingram .....	847	4884, 5414, 5573, 6498, 7885, 8075	
— MacNaught .....	847	— arrangement for separating, from oil .....	425
— Schultz .....	855	— "blue" .....	932
— Tagliabue .....	855	— from brown coal-tar .. br. 4658	
— Thurston .....	849	— capacity of strata .....	163
— Woodbury .....	847	— carburation of .. br. 1100, 2652, 3595, 4607,	
— testing of lubricating oils .....	842	4617, 4621, 4622, 4628, 4889, 5917, 8549,	
Fucino Lake; inflammable gases from .. br. 127		8558, 8733	
Fuel (general) .. br. 2302, 2512, 2963, 3584,		— condition found under .....	160
3679, 4275, 4631, 4632, 6420, 7740, 8588		— detection of inflammable .. br. 1400, 1402	
— liquid .. br. 3, 65, 128, 258, 364, 374, 377,		— of sulphur in .. br. 2303	
461, 582, 711, 712, 819, 832, 903, 905, 907,		— dry .....	587, 934
991, 1022, 1128, 1148, 1149, 1246, 1286,		— duration of the supplies .....	172
1296, 1345, 1368, 1385, 1435, 1803, 1955,		— fields of Russia .....	205
2271, 2324, 2463, 2947, 2953, 3207, 3282,		— of the U.S.; natural .....	206
3390, 3391, 3560, 3590, 3599, 3634, 3635,		— fires; extinguishing natural .. br. 8274	
3886, 4025, 4026, 4494, 4630-4632, 4741,		— flames; luminosity of .. br. 4619, 4624	
4776, 5365, 5402, 5603, 5662, 5782, 5783,		— liquified; Blau process of making .....	927
5794, 5920, 5921, 5923, 5957, 6203, 6464,		— Low process for making illuminating .....	928
6563-6566, 6623, 6648, 6709, 6829, 7062-		— mantles .....	897, 899
7068, 7089, 7564, 7590, 7645, 7739, 7858,			
8211, 8292, 8396, 8401, 8455			

	PAGE		PAGE
Gas manufacture (general) . . . . .	1140, 1904, 3250, 6759, 8550	Gas oils; testing . . . . .	743
— in metalliferous mines . . . . .	<i>br.</i> 1047	— producer; Pentland . . . . .	615
— natural, in the Baku fields; historical . . . . .	11	— regulator; Westinghouse . . . . .	933
— natural; analysis . . . . .	342	— reservoir-rocks . . . . .	161
— calorific power . . . . .	343, 344	— strata; protection of . . . . .	<i>br.</i> 361
— in Canada . . . . .	<i>br.</i> 65, 185, 186, 343, 1064, 1066, 1491, 1493, 1725, 1726, 2280	— structural conditions affecting accumulation of — from tar, etc. . . . .	164 42
— composition . . . . .	<i>br.</i> 399, 765, 1020, 1166, 1167, 1305, 2389, 3321, 4903, 5361, 6068- 6072, 6076, 6077, 6251, 6423, 6777, 6798- 6801, 7070, 7760	— trap; American . . . . .	539
— of American . . . . .	343, 345, 346	— water; carburetted . . . . .	<i>br.</i> 3595, 4621, 7358, 7655
— of Canadian . . . . .	344	— paraffins in . . . . .	<i>br.</i> 5415
— of European . . . . .	345, 346	— well depths . . . . .	83, 135, 205
— of Pechelbronn . . . . .	346	— section in Ontario . . . . .	83
— of Russian . . . . .	345	— wells; estimating the production of . . . . .	429
— distribution of to consumer . . . . .	934	— of Ohio . . . . .	429
— geological and geographical distribution . . . . .	160-162	— of Pennsylvania . . . . .	429
— geology of . . . . .	<i>br.</i> 335, 736, 1159, 1350- 1361, 1566, 1614, 1770, 8317, 8318	— pressure in, and its cause . . . . .	170
— in Great Britain; occurrence of . . . . .	38, 42	— pumping and compressing engines for use in — in the U.S. . . . .	430 428
— in Heathfield, Sussex . . . . .	<i>br.</i> 1642, 1786, 3336, 5966, 8489	— record of natural, 1907-1918 . . . . .	1101
— in Hungary . . . . .	25	Gases; ignition temperatures of . . . . .	<i>br.</i> 1787
— in Indiana, 1897-1910; record of . . . . .	1103	Gasoline; absorption process . . . . .	588
— inorganic theories . . . . .	348	— American . . . . .	541
— in Italy; production of, 1903-1910 . . . . .	1112	— from Baku oils . . . . .	557
— in Kansas, 1897-1910; record of . . . . .	1107	— bromine test of . . . . .	868
— manufacture of lamp-black from . . . . .	933	— compression process . . . . .	588
— in New York, 1897-1910; record of . . . . .	1106	— evaporation of, by a current of air . . . . .	913
— in Ohio . . . . .	107	— from natural gas . . . . .	<i>br.</i> 989, 1461 . . . . . 431, 587, 934, 935
— 1897-1910; record of . . . . .	1105	— and pentane; experiments with, evaporated — in explosion chamber . . . . .	708 708
— in Oklahoma, Kentucky, and Illinois, 1906- 1910; record . . . . .	1108, 1109, 1110	— properties of . . . . .	<i>br.</i> 628
— organic theories . . . . .	353	— vapour; explosion of, mixed with air . . . . .	708
— origin of . . . . .	<i>br.</i> 1491, 1493, 2390, 3625, 3763, 5476, 5477, 6074, 6786	( <i>See also</i> Natural-Gas Gasoline.)	
— in Pennsylvania, 1897-1910; record . . . . .	1102	Gasolines; blended casing-head . . . . .	939
— production and consumption in New York and Pennsylvania . . . . .	102, 103	Gaspé oil-fields . . . . .	<i>br.</i> 2007, 2012
— in the U.S. . . . .	932	Gawalwiski, A.; flash-point tester . . . . .	806
— and value in Canada . . . . .	1111	Gedanite . . . . .	<i>br.</i> 3238, 8681
— pumping . . . . .	<i>br.</i> 4890, 6443, 8237	Gemsh; petroleum deposits . . . . .	50
— radioactivity of . . . . .	<i>br.</i> 4940	Geneva; petroleum regulations 1903 . . . . .	1049
— in Russia . . . . .	448	— regulations as to manufacture, storage, etc., of — petroleum in . . . . .	1034
— Salsomaggioire and Salsominore . . . . .	31	Geology of petroleum and natural gas . . . . .	160 <i>et seq.</i>
— transport of . . . . .	<i>br.</i> 2036, 2268, 6605, 6606	Geological conditions favouring gas collecting . . . . .	162
— in the U.K.; quantity and value of produc- tion . . . . .	1112	— oil collecting . . . . .	162
— in the U.S. . . . .	<i>br.</i> 338-342, 398, 757-758, 963-967, 970, 1119, 1232, 1530, 1663, 1834, 2306, 3060-3062, 3779, 4595-4598, 4610, 4755	Georgia; occurrence of oil in . . . . .	226
— value of production in U.S. . . . .	1099-1100	— testing and storage regulations . . . . .	1051
— in West Virginia . . . . .	103	Geran oil district . . . . .	<i>br.</i> 1094
— record of 1897-1918 . . . . .	1104	German Protectorates and Colonies; import duties — on petroleum products . . . . .	1140 857-860
(general) . . . . .	<i>br.</i> 446, 460, 562, 771, 1008, 1288, 1289, 1304, 1305, 1377, 1601, 2179, 2709, 2848, 3359, 4738, 4830, 4915, 5760, 6139, 7084, 7336, 7731, 7430-7432, 7446, 7702, 7789, 8095, 8174, 8247, 8248, 8250, 8251, 8275, 8322, 8351, 8688	— regulations as to mineral oils . . . . .	1023
( <i>See also</i> Natural-Gas Gasoline.)		Germany; asphaltum industry . . . . .	<i>br.</i> 7206
— oil . . . . .	<i>br.</i> 292, 496, 627, 873, 953, 1021, 1116, 1124, 1324, 1375, 1385, 1844, 1878, 1904, 1951, 1952, 1953, 1979, 2545, 2641, 2659, 2843, 2864, 2876, 2906, 2910, 3048, 3130, 3249, 3367, 3378, 3779, 3897, 4042, 4253, 4269, 4277, 4279, 4394, 4397, 4499, 4620, 4678, 4878, 4879, 5118, 5189, 5696, 5720, 6035, 6058, 6089, 6192, 6407, 6498, 6505, 6696, 6697, 6858, 6883-6885, 6901, 7055, 7057, 7376, 7521, 7619, 7655, 7701, 7755, 8106, 8107, 8390	— production in . . . . .	1122
— and coal-gas; properties of mixtures of . . . . .	931	— composition of asphalt-rock . . . . .	334
— Tocher's experiments with . . . . .	931	— directions for use of Abel-Pensky tester in . . . . .	787
— experiments . . . . .	932	— distribution of petroleum in . . . . .	195
— manufacture of . . . . .	921	— import duties on petroleum products in . . . . .	1140
— plant . . . . .	922-927	— petroleum in . . . . .	<i>br.</i> 617, 985, 1001, 1853, 1859, 2063, 2167, 2307, 2433, 2560, 2844, 3559, 3896, 4125, 4165, 4190, 4236, 4428, 4714, 5274, 5276, 5288, 5347, 5452, 5454, 5639, 6149, 6271, 6272, 6628, 6633, 6773, 6774, 7483
— production; Tocher's experiments . . . . .	923 <i>et seq.</i>	— industry; historical . . . . .	37
— and oil, relative costs of for illuminating . . . . .	899	— refining in . . . . .	571
— use for railway-carriage lighting . . . . .	924	— production of petroleum in (France) . . . . .	473
— oils . . . . .	<i>br.</i> 3249, 4781, 6699, 6700	— and value of crude oil in . . . . .	1091
— apparatus for distilling . . . . .	<i>br.</i> 2003	— specific gravity and flashing-point of crude — petroleum from . . . . .	265 840
— correction of specific gravity for temperature . . . . .	273	Gibb's viscometer . . . . .	809
		Gibraltar Petroleum Ordinance of 1884 . . . . .	1029
		Gibsonburg field, Ohio . . . . .	107
		Gilsonite . . . . .	<i>br.</i> 1670, 1671, 1989, 4963, 6121
		( <i>See also</i> Uintaite.)	
		Gintl, coefficient of expansion; relation of, to — specific gravity . . . . .	268, 269
		Glass industry; licensed silvers in London using — petroleum . . . . .	991
		— liquid fuel firing in the . . . . .	<i>br.</i> 128, 4986
		Glinoj Balka; borings at . . . . .	14
		Globes; lamp . . . . .	901
		Glodeni oil field . . . . .	<i>br.</i> 7078
		Gloss coal . . . . .	643
		Glove cleaners in London; licensed to use — petroleum . . . . .	991
		"Go-devil" . . . . .	427
		"squib" . . . . .	427

	PAGE		PAGE
Gold Coast; import duties on petroleum and products	1140	Hatchett; definition and classification of bituminous substances	255
— petroleum deposits	157	Hatchettine . . . . . <i>br.</i> 1285, 1307, 1448, 3037, 3772, 3773, 5198, 5401, 8105	104
— specific gravity and flashing-point of crude petroleum from	265	Hatchettite . . . . . <i>br.</i> 1756, 4754	182
Goldstein, A. H., <i>see</i> Mabery, C. F.	277	( <i>See also</i> under Ozokerite.)	
Gorjeff burner	959	Hawarden Castle; explosion on the s.s.	697
Gorlice oil-field, Galicia; historical	21	Hawking petroleum	997
Grabs . . . . . 385, 384, 385, 386		Hayti; distribution of petroleum deposits	247
— rope	383, 384	— import duties on petroleum products	1141
Grahamite . . . . . <i>br.</i> 783, 1881, 4039, 4040, 6553, 7572, 8321, 8518, 8519	329	— occurrence of oil in	139
— and allied materials, analyses of	336	Heat of combustion; estimation of . . . . . <i>br.</i> 2299, 3252, 4271, 7094, 7707	898
Graham's perforator	406, 407	— emitted by oil and by gas	280
Granier; flash-point tester and its use	800	— of vapourisation	280
Granular bed process of combustion	1318	Heathfield, Sussex; natural gas at . . . . . <i>br.</i> 1642, 1643, 1786, 3336, 5966, 4489	42
Grapeville gas-field, Pa.	<i>br.</i> 4598	Heating with hydrocarbons . . . . . <i>br.</i> 364, 488, 1413, 1977, 2511, 2553, 2632, 2945, 2965, 4027, 4517, 4959, 5212, 6308, 6516, 6595, 6709, 6806, 7271, 8022	911
Gravity petroleum	269	— oils . . . . . <i>br.</i> 2878	911
Gray's flash-point tester for heavy oils	816	— stoves	897
Greases; viscometer for	834	Heavy-oil lamps; Makaroff's	505
Great Britain; Acts, etc., relative to storage, testing, etc., of petroleum in	979	— and paraffin redistillations	703
— petroleum industry; historical	38	Ieck, J. H.; explosive mixtures of petroleum vapour and air	502, 503, 504
— use of oil-fired locomotives in	947	Heckmann naphtha stills . . . . . 502, 503, 504	505
( <i>See also</i> England and U.K.)		— still gauge	505
Greece; distribution of petroleum in	188	Heel-ball	563
— import duties on petroleum products	1141	Helena field, Ohio	107
— sale of petroleum in	1029	Helenite . . . . . <i>br.</i> 5536	991
Greenland; distribution of petroleum in	221	Helmet manufacturers in London; licensed using petroleum	41
Grenada; import duties on petroleum products	1141	Hemsworth Collieries; oil springs at the	623, 624
— Inflammable Goods Ordinance, 1891	1030	Henderson, N. M.; ammonia still	639-641
— occurrence of oil round	247	— paraffin sweating process	625, 626
Grey shale	600	— shale retorts	613, 615
Gripper, H.; estimation of hydrocarbons in compound oils	875	Heneicosane	304, 313
Growtowsky; determination of solid hydrocarbons in mineral oil	879	Hentricoutane	327
Grozni . . . . . <i>br.</i> 2, 106, 1093, 3147, 3807, 3824, 4186, 4491, 4493, 4495, 5163, 6198, 7316, 7466, 7468, 7469, 8564, 8569, 8570-8574	202	Heptanaphthylenes . . . . . <i>br.</i> 5073, 5078, 5079, 5082	278, 303, 311
— field; historical	12	Heptane	280
— particulars of the wells in the	1081	— heat of vapourisation	277
— production of crude oil	1081	— specific heat of	311
— yield of wells in	448	Heptanes from petroleum . . . . . <i>br.</i> 1486, 2406, 3929	697
— petroleum and naphtha . . . . . <i>br.</i> 111, 3902, 3917, 3931, 3940, 3941, 3945, 3946, 3980, 4014, 4187, 4198, 5074, 6379, 6731, 6817, 7470	290	Hercules; explosion on H.M.S.	196
— petroleum; physical properties of	290	Hesse and Hesse-Nassau; petroliferous deposits	858
Guadeloupe; import duties on petroleum products	1141	Hessian Ludwigsbahn Railway Co., lubricating oil specifications	796
Guam; discharges of carburretted hydrogen on	217	Heumann's electric flash-point tester	652
Guatemala; import duties on petroleum products	1141	Heusler; brown-coal tar oils at Webau; treatment of	313
Guayaquilite . . . . . <i>br.</i> 3773		Hexacosane	311, 313
Guernsey; import duty on petroleum, etc.	1141	Hexadecane	277
— petroleum laws of, 1914	1030	— specific heat of	311, 313
Gulf field, U.S.A.; development of the	113	Hexamethylene from petroleum . . . . . <i>br.</i> 2373	311
— production, value, and price of crude oil	1070	Hexane	280
Gulf Pipe-Line Co.'s line	663	— heat of vapourisation	277
"Gum oil"	125	— specific heat of	169
— beds"	58	Hildreth, S. P.; saliferous rocks in Ohio	86
Gunda, Punjab; petroleum near	15	— early use of petroleum	489, 490
Guri district, Kutais; petroleum in the	796	Hill, S. A., and C. F. Thumm; continuous still	890-892
HAASS; flash-point tester	75	Hinks's Duplex burner	1055
Hagashiyama oil-field, Japan	198	Hoboken; storage regulations	315
Halle; brown-coal industry of . . . . . <i>br.</i> 114	868	Höfer, olefines from N. American petroleum	352, 353, 355, 358, 359
Halphen, G., <i>see</i> Riche, A.	1028	— origin of petroleum	267
Hamburg; petroleum law and harbour regulations	448	— physical properties of commercial petroleum products	879
Hand-drilling system; the Galician	333	Holand, R.; estimation of solid hydrocarbons in mineral oils	879
Hanks, H. G.; Californian asphalt-rock	907	— sulphur in mineral oils; determination of	75
Hannay, <i>see</i> Lyle	197	Hokkaido; discovery of oil at	880
Hanover; asphalt in . . . . . <i>br.</i> 7827	197	Holde; separation of solid hydrocarbons from mineral oils	949-951, 960
— mineral oils of . . . . . <i>br.</i> 84		Holland; import duties on petroleum products	1031
— petroleum in . . . . . <i>br.</i> 858, 1542, 1544, 4561, 4562, 6136, 6137, 6630	37	— petroleum laws	4. 11
— in the district	1029	Holy Island petroleum; historical	246
— regulations of 1903	197	Honduras; distribution of petroleum in	1141
— petroliferous deposits	1091	— import duties on petroleum products	3008
— production and value of crude oil in	4, 5	— oil-fields	1032
Hanway, J.; Baku petroleum in 1754.	1007	Hong Kong; Dangerous Goods Ordinances	920
Harbour bye-laws; model code of	1002	Hooker's "safety-gas" process	720
— as to petroleum	1027	Horley-Sedgley water finder	382
— regulations; Bremerhaven	1028	"Horn socket"	970, 971
— Hamburg	1028	Hornsby-Akroyd oil engine	970, 971
Harburg; oil fire at . . . . . <i>br.</i> 120			
Hartite . . . . . <i>br.</i> 3033, 6738			

	PAGE		PAGE
Howard, C. C.; composition of Ohio natural gas ..	345	Hydrocarbons (general) . . . . .	1276, 1874, 1875,
Hudson Bay . . . . .	219	1878, 2458, 2460, 4244-4250, 4543, 7711	
Huidobro, Spain; petroleum in . . . . .	47	Hydrogen; natural . . . . .	br. 720, 721
Hungary; asphalt production in . . . . .	1122	— in petroleum and bitumen; determination of . . . . .	br. 4657
— natural gas in . . . . .	192	— in petroleum; percentage of . . . . .	299
— oil-fields of . . . . .	25	Hydrostatic pressure of oil . . . . .	171
— petroleum in . . . . .	262, 264, 272, 485, 486,		
839, 840, 2586, 2591, 3541, 3758, 5154,		ICHTHYOL . . . . .	883
5156, 5157, 5568, 5569, 5675-5677, 5679,		Idaho; occurrence of petroliferous deposits in . . . . .	243
5680-5683, 5745, 5746, 5771, 5858, 5928,		— petroleum and natural gas . . . . .	br. 8204
6222, 6324, 6897, 7643, 7644, 8158-8166,		— testing in . . . . .	1051
8169-8171, 8178, 8437		Idrialite . . . . .	br. 6875
— and asphalt deposits in . . . . .	191	Idryl and idrialine . . . . .	br. 844, 2669-2671, 6981,
— production and value of petroleum in . . . . .	1094, 1096, 1097	6982, 6984	191
— specific gravity and flashing-point of crude petroleum from . . . . .	265	Ignition of petroleum; temperature of, of petroleum vapour and air; conditions of . . . . .	709, 710, 711
Hunt, S.; origin of petroleum from marine organisms . . . . .	353	— point of mineral oils; testing the . . . . .	763
Huzaree district . . . . .	br. 5	— temperature of lower hydrocarbons . . . . .	710
Hydrocarbon oils; separation from fatty oils	br. 162	Illinois; distribution of petroleum and gas in . . . . .	232
Hydrocarbons . . . . .	303	— oil-fields . . . . .	br. 412, 413, 415, 418, 419, 793-
— from acetylene; formation of liquid . . . . .	350	795, 797, 798, 800-802, 804, 8303-8305	
— aliphatic . . . . .	304	— petroleum industry in . . . . .	109
— analysis of . . . . .	br. 2439	— production in . . . . .	1066
— aromatic . . . . .	308, 505	— production of natural gas in . . . . .	110
— from naphtha and bitumens . . . . .	br. 71	— record of the natural gas industry in, 1906-1918 . . . . .	1119
— boiling-point, critical temperature and pressure of the lower paraffin . . . . .	936	— storage and testing regulations in . . . . .	1051
— from brown-coal tar . . . . .	br. 1105	Illuminating agents; petroleum products as . . . . .	883
— from carbides . . . . .	br. 139	gas; Low process for making . . . . .	928
— carburetting of coal gas with vaporised . . . . .	915	hydrocarbons; synthesis . . . . .	br. 4625
— classification of natural . . . . .	br. 5857	oil; exports from U.S. . . . .	1069
— closed chain . . . . .	307	— from U.S., 1892-1918 . . . . .	1075-1078
— cold fractional separation of . . . . .	br. 3958	— imports and exports, Austria-Hungary . . . . .	1082-1083
— from compressed gas . . . . .	br. 2137	— production, consumption, and exports of Rumanian, 1890-1919 . . . . .	1084
— continuous rectification of . . . . .	br. 449	— of in Canadian refineries . . . . .	1092
— cyclo . . . . .	308	— oils . . . . .	br. 1958, 3907, 3925, 3942, 3988, 4713,
— from the distillation of fatty acids . . . . .	br. 1169	5084, 5511, 5795, 6022, 6706, 6710, 7330,	
— effect of heat on . . . . .	br. 294, 295, 654, 657,	7689, 7690, 8042, 8046, 8048, 8051-8059,	
666, 891, 893, 2098, 2998, 4668, 4669		8063, 8066, 8308, 8599, 8699, 8690	
— emulsification of . . . . .	br. 1814	— Russian . . . . .	556
— estimation in crude petroleum of solid . . . . .	877-879	— testing . . . . .	br. 1421, 2916, 4059, 4062, 4063,
— in lignite tar oils . . . . .	654	4066, 4070, 4082	
— evaporation by a current of dry air of certain . . . . .	912	— power of coal-gas . . . . .	927
— formation by action of water or carbides of . . . . .	349	— of kerosene; tests of . . . . .	760
— of . . . . .	br. 649, 671, 672, 676, 6055	— and oil consumption of lamps . . . . .	897-899
— geological distribution of . . . . .	br. 599	Illumination (general) . . . . .	br. 450, 498, 546, 817,
— have many forms . . . . .	160	902, 1059, 1130, 1309, 1685, 1721, 1722,	
— heats of vaporisation of various petroleum . . . . .	280	2281, 2413, 2491, 2507, 2532, 2533, 2549,	
— heavy, with petroleum . . . . .	582	2644, 2917, 2918, 2941, 2972, 3324, 3325,	
— ignition temperatures of lower . . . . .	710	3710, 4284, 4293, 4395, 4618, 4895, 5021,	
— from Japanese petroleum . . . . .	br. 1785	5088, 5356, 5472, 5919, 5951, 6035, 6475,	
— largest proportion in oils . . . . .	284	6904, 6927, 7076, 7338, 7447, 7476, 7525,	
— from Louisiana petroleum . . . . .	br. 1403, 1404	7848, 8023, 8078, 8234, 8243, 8244, 8582,	
— menthane or paraffin . . . . .	310	8644, 8645	
— methylene . . . . .	277, 278	— incandescence with petroleum vapour . . . . .	br. 560,
— naphthalene . . . . .	309, 310	1802, 2513, 4089, 4090, 4629, 6884, 7840	
— of the natural petroleum series . . . . .	br. 49	Imbert; sinking of artesian wells in China . . . . .	366
— nature of, in petroleum . . . . .	br. 493-495, 578,	Import duties on petroleum and its products in various countries . . . . .	1132
1943, 1947, 1982, 2128, 2810, 4098, 4843,		Incandescence oil lamps . . . . .	900
4845, 4847, 5412, 6284, 6953, 6955-6958,		Indene . . . . .	654
6966, 7180, 7201, 8390, 8581, 8596, 8636,		India rubber; mineral . . . . .	39, 329
8655-8657	303	(See also Rubber.)	
— from Ohio petroleum . . . . .	313	India; distribution of petroleum in British . . . . .	213
— open chain . . . . .	303	— flash-point legislation . . . . .	781
— oxidation of . . . . .	br. 1847, 3134	— import duties on petroleum and products in . . . . .	1135
— paraffin . . . . .	303, 304	— Petroleum Act, 1899 . . . . .	1032
— from Pennsylvania petroleum . . . . .	313	— petroleum deposits in; historical . . . . .	55
— of petroleum; solubility in acetone . . . . .	br. 6256	— legislation . . . . .	br. 5147
— specific heats of . . . . .	278	— testing schedule . . . . .	782
— physical properties of the saturated . . . . .	317	— production and value of crude petroleum in . . . . .	1087
— products yielded by various . . . . .	926	Indian Territory, U.S.A. . . . .	br. 112, 1531-1534
— properties of . . . . .	br. 652, 658, 659, 663, 664,	— specific gravity and flashing-point of crude petroleum and flashing-point of . . . . .	261
675, 684, 685, 689, 717, 2305, 2407, 2997		Indiana crude petroleum; specific gravity and flashing-point . . . . .	261
— proportion of solid, in crude oils . . . . .	284-286	— distribution of petroleum and gas-fields . . . . .	231
— for purifying alcohol . . . . .	886	— natural gas industry . . . . .	109
— solid . . . . .	879	— production, 1916 . . . . .	109
— in crude oils . . . . .	326-328	— petroleum industry in . . . . .	108
— saturated . . . . .	303	— production in . . . . .	1066, 1067
— from shale-oil . . . . .	br. 6796	— pipe-lines in . . . . .	661
— from spiegeleisen; formation of liquid . . . . .	349	— pressure of gas in . . . . .	171
— synthesis of . . . . .	br. 182, 647, 650, 2438, 4414,	— record of the natural gas industry in 1897-1918 . . . . .	1103
4625, 5024, 5159, 5360, 6267, 8010, 8282,		— State flash-point test . . . . .	766
8389, 8517			
— theory of formation in nature . . . . .	361		
— unsaturated . . . . .	br. 1135, 1136, 1138, 2717, 4659		
— viscosity . . . . .	295		



	PAGE		PAGE
Indiana; storage and testing regulations	1052	Jerker rope	387
— (general) . . . . . br. 603, 803, 805, 910, 970, 1425-1429, 1912, 2030, 2031, 2481, 2484, 2485, 2705-2708, 3790, 4051, 4115, 4501, 4600, 4610, 4900, 5708, 6086, 6568		— wheel	435
Indo-China; import duties on petroleum products	1142	Jersey; import duties on petroleum products	1142
Inducing flow from well	420	— Petroleum Law	1037
Inflammable Liquids Bill, 1891	772	Jet	br. 755, 954
Ingram and Stapfer; lubricant tester	851, 853	Jew's pitch	256
Injector; Holden oil-fuel	949	Jones, see Bryson	618
Insecticide; petroleum as	br. 4177	Joints, fitting of	377
Inserted joint casing	418	Jujuy; petroleum and asphalt in	br. 983, 1860, 4325
Inspection box; American	540	Jura asphalt	br. 6874
Insulating material from ozokerite residues	563	KACHETIKN	br. 7321
— bituminous materials	br. 7517	Kaiseröl	br. 1081
International Petroleum Commission	792	Kaitago-Tabasaran oil-field	br. 2677
Iodine value of mineral oils	br. 2742, 2747, 2748	Kal'ah Sherkat	br. 89
— absorption of oil	341	Kanawha River, Virginia; gas wells of	br. 170, 4635
Iola, Kansas	br. 3877, 5451, 5813, 5914	Kansas; distribution of the petroleum deposits in	237
Ionite	br. 6300	— geology of	br. 2839, 2840, 3170-3172, 9668-9971
Iowa; occurrences of natural gas in	233	— natural gas in	br. 398, 1267, 1530, 3168, 3169, 3173, 3175-3179, 5182
— testing and storage regulations	1052	— gas-fields in	111
— (general) . . . . . br. 60, 410, 411, 1194, 1195, 3998, 4567, 4568		— petroleum in	br. 112, 503, 504, 1825, 1912, 3168, 3169, 3173, 3174, 3176-3179, 3339, 5335, 6970, 8462
Ireland; occurrence of petroleum in	175	— industry in	110
Iron industry; use of petroleum and natural gas in	br. 2576, 4351, 5963	— production in	1066
— oxide in the ash of petroleum	303	— record of the natural gas industry in, 1897-1918	1107
Isle of Man; Dangerous Goods Acts and storage regulations	1033	— testing and inspection regulations in	1052
Isododecane	278	Karamania Coast	br. 536
Isodulor derivatives	br. 732	Kazan	br. 2120, 2130, 2582, 7521, 8124
Isoheptane	278	Keates's close-test instrument	767
Isohexane	320	Keith's oil-gas plant	922-923
Isoxylene	315	Kelth; occurrence of petroleum at	41
Istria; asphalt limestone in	191	Kent gas-field, Canada	br. 5291
Italian well-digging	371	Kentucky; asphalt-rock in	br. 1109, 5809
Italy; asphalt production in, 1900-1909	1123	— distribution of petroleum	228
— distribution of petroleum in	183	— natural gas in	br. 2306, 3422, 5809
— geology of	br. 509, 561, 3743-3745, 5178, 5354	— production	105
— import duties of petroleum products	1142	— oil-fields of	br. 2307, 3422, 4586-4588, 5809, 6791
— petroleum in	br. 383, 427, 725, 1155-1157, 1198, 1200, 1221, 1223-1225, 1279, 2129, 2184, 2325, 2385, 2386, 2749, 3747, 5449, 5467, 5855, 6207, 6323, 7440, 7971, 8021, 8742	— petroleum production in	1066
— petroleum industry; historical	31	— pipe-lines	661
— production	35, 36	— record of the natural gas industry in, 1906-1918	1109
— storage, etc., regulations in	1034	— storage and testing regulations	1052
— the petroliferous water wells of	371	Kergison Desert; oil of the	br. 930
— production of natural gas in, 1903-1915	1112	Kermode's liquid fuel burner	954, 955, 956, 958
— of petroleum, 1860-1918	1093	Kern County, California	br. 463, 5901, 6289
— specific gravity and flashing-point of crude petroleum from	265	Kern River field, California	116
Ivory Coast; specific gravity and flashing-point of crude petroleum from	265	Keroseline (anæsthetic)	br. 5878
Ixolyte	br. 3034	Kerosene Act of Newfoundland	1039
ixomètre; Barbey's	839	— alkali test for	870
JABA, Punjab	br. 1611	— from Baku oils	556
Jamaica; import duties on petroleum products	1142	— for boilers	br. 4826
— Petroleum Law of 1906	1035	— Canadian refined	554
Japan; asphalt production in, 1900-1912	1123	— colour improving	559
— distribution of petroleum in	214	— definition of, in Bahamas	1013
— import duties on petroleum products in	1142	— determination of colour of	761
— methods of producing petroleum in	365	— of flashing-point and fire-test of	763
— petroleum and natural gas in	74	— of the odour of	762
— regulations in	1035	— distillate; chemical treatment in America	541
— production of petroleum in	76, 1089	— treating	526
— specific gravity of crude petroleum from	267	— distillation residues; treatment of in the U.S.	542
— (general) . . . . . br. 56, 458, 4160, 4161, 4818-4823, 5260, 5337, 5487, 5627, 6058, 6341, 7403, 7579, 7580, 8803		— domestic storage tank for	724
Japan Oil Company	75	— flashing-point raised by "spraying"	559
Japanese petroleum	br. 4870, 5098, 6397, 7581, 8126	— fractions	757
Jar-latch	384	— of American and Russian	758
Jars	372	— grades of	556
Java; distribution of petroleum in	541	— illuminating power of	br. 141, 4694
— petroleum fields in	68	— import duties in various countries	1132
— production of petroleum in	1083	— importation into England	715
— specific gravity and flashing-point of crude petroleum from	266	— into Europe	716
— (general) . . . . . br. 2420, 2421, 2656, 3804, 3805, 4941, 6332, 6427, 6471		— Industry in the Caucasus	br. 2961
Jebel-Zeit, Egypt; petroleum deposits at	50	— neutrality	875
		— New York Produce Exchange Rules	756
		— odour, to get rid of	541
		— Petroleum Oil Exchange Rules	756
		— properties of	br. 628, 986, 1819, 2608, 3938, 3992, 4320, 8183
		— proportion of in various crude oils	284
		— purification of	br. 3967, 3978, 3989
		— redistillation	505
		— relative capillary power of three kinds of	293

	PAGE		PAGE
Kerosene shale produced in New South Wales, 1865-1909	1130	Lamp wicks	903
— shales . . . . <i>br.</i> 215, 425, 699, 701, 705, 708, 709, 1247-1250, 1627, 1641, 2814, 6160, 6608, 7203, 7860	604	Lamp-black; analysis of	<i>br.</i> 6840
— — from New South Wales	604, 605	— manufacture	<i>br.</i> 5537
— solidified	<i>br.</i> 1780	"Lampe Belge"	892
— specific heats and specific gravities of various kinds of	279	— Veritas	894
— test for neutrality of	756, 875	Lamps; construction and management of	906, 1008
— testing . . . . <i>br.</i> 574, 1821, 2001, 4319, 4711, 4712, 8755, 8760	741, 755	— explosions with	<i>br.</i> 355, 4976, 7715
— — Baku	559	— heat developed	898, 899
— tests for burning quality of	759	— illuminating power and oil consumption of	898, 899
— — of the illuminating power of	760	— mineral oil	889
— tins for carrying	673	— spirit	909
— transport and distribution of in the U.S.	670	— photometric	<i>br.</i> 2002
— use of slaked lime in refining at Baku	559	— for solid paraffin	910
— vapour and air; conditions of ignition of	710	— spray	907
— variation of specific gravity of, with temperature	273	— for use on ships	907
— water-white	755	Lamps, various types of:—	
— U.S.; Fuel Administration's specifications	755	"Anacapnic" burner	892, 893
— (general) . . . . <i>br.</i> 1308, 1478, 2035, 2595, 3644, 3940, 4321, 4693, 4871, 5739, 6339, 6340, 7069, 7523, 8184, 8332		"Arfa" lamp	895
Kerosenic acid and its salts	<i>br.</i> 7741	Benzoline	909
Kertch	15, 201	Calorific value	899
— geology of	<i>br.</i> 27, 2840	Comparison of wicks	896
Khatan, Baluchistan; petroleum deposits in	55-57	Cosmos burner	896
Khidirzindl	<i>br.</i> 8562, 8563, 8566	"Defries" lamp	892
Kimmeridge shale	<i>br.</i> 2812	Duplex burner	890-892
Kind's free-fall borer	453, 455	Kitson	900
King Wells, Pretoria, Canada	78	"Lampe Belge"	892
Kingzett, C.; determination of bituminous matter in asphalt-rock	881	"Lampe Veritas"	894
Kir	17	Legge's lamp	920
Kirwan; oil from the black clays of Persia and Media	256	"Lonie" burner	892
Kishm, Persian Gulf; petroleum in	52	Lucigen lamp	907, 908
Kissling, R.; fractionation of petroleum spirit	754	Makaroff's heavy-oil lamp	897
Kitson, A.; incandescent mantle oil-lamp	900	"Mitralleuse" burner	893, 894
Kleeburg	46	Non-luminous flame	900
Koettstorfer process of testing compound oils	874	"Perpetual" lamp	903
Kohat; oil-springs near	<i>br.</i> 7722	Robert's Gem	890
Kohinoor; explosion on the barge	697	Rochester lamp	894, 895
Korea; petroleum and gas in	<i>br.</i> 6827	Safety appliances	903
Körösmező . . . . <i>br.</i> 4559, 6216, 6218, 6221, 7339, 7555, 8160, 8164, 8169, 8232		"Sunlight" lamp	895, 896
Körting burner	957	"Victoria" lamp	902
Kotuku oil district, N.Z.	154	"Wanzer" lamp	895
Krämer; origin of petroleum	355	"Water" safety lamp	902
Kuban district; petroleum deposits in; historical	14	"Wells" lamp	907, 909
— petroliferous deposits in the	<i>br.</i> 868, 2603, 2895, 5615, 6112, 6228, 6229, 6664, 6665, 7620, 8420, 8575	(General) . . . . <i>br.</i> 12, 13, 142, 143, 229, 730, 937, 1401, 1729, 2337, 3393, 3431, 3704, 3853, 4299, 4328, 4435, 4708-4710, 4800, 4807, 4808, 5137, 5221, 5516, 5634, 5870, 6007, 6046, 6150, 6446, 6520, 6866, 6915, 7329, 7365, 7618, 7709, 7766, 8364	
— physical properties of petroleum	289	Lancashire; petroleum in	<i>br.</i> 743 . . . . 39, 40, 41, 176
Kubierschky distillation process	<i>br.</i> 923	Lander oil	<i>br.</i> 1002
Kubiki oil-field, Japan	75	Langkat; petroleum in	<i>br.</i> 6508
Kudako; petroleum deposits at; historical	15	Launch engine; "Zephyr"	977
Künkler; physical properties of various lubricating oils	293	Launches; gasoline	<i>br.</i> 1528
— viscometer; comparison of, with Engler's	838	— Thames Conservancy Byelaws for petrol motor	1152
— for greases	834	Lawrence system of surface condensation	509
— for small samples	836	Lead; action of petroleum on	<i>br.</i> 2396
— for use at low temperatures	834	— blast furnaces; use of natural gas in	<i>br.</i> 774
— see Engler	826	Leadbeater, J. W., petroleum; solidification of	885
Kutais; petroleum in the Guri district of	15	Leaf-coal	643
— petroliferous deposits	203	Leaf-shale products	648
LABARGE oil-field, Wyoming	<i>br.</i> 7000	Leases of oil properties in the U.S.	373
Labrador; specific gravity of crude petroleum from	259	Leasing oil lands	<i>br.</i> 3190
Labuan; petroleum in	71	Legge's lamp for burning oil-vapour with a mantle	920
— Petroleum Ordinance	1037	"Leutz" method of connecting lengths of casing	442
Lach, B.; ozokerite refining	569	Leptometer; Lepenau's	839
— valuation of	877	Le Roy, G. A.; refractive indices of various petroleum	297
Ladron Islands; carburetted hydrogen discharges in the	217	Lesignano de' Bagni petroleum deposits	31
Lagos; import duties on mineral oils	1142	Lesley, J. P.; oil-fields, geology of	173
Lamansky-Nobel viscometer	<i>br.</i> 8444	— petroleum; origin of	353
Lamp accidents	904	Lethey's electric flash-point tester	794
— burners	896, 898	Lewes, V. B. lamps; consumption of oil and efficiency of various	897
— for burning oil-vapour with mantle; Legge's	920	Liberia; import duties on petroleum	1143
— extinguishers	901, 902	Licenses; London County Council petroleum	994
— globes	901	— to use petroleum in industries; report to L.C.C. on	991
— oils	<i>br.</i> 4713, 5924	Liebermann's flash-point method	805
		Lietzenmayer oil motor	<i>br.</i> 8341
		Light, action on kerosene	523
		Light oil from Nigeria; characters of a	157
		Lighthouse illumination	<i>br.</i> 4875
		— oil; testing	742
		Lightning conductors and oil storage	713
		Lignite	602, 641
		— composition of various kinds of	642

	PAGE		PAGE
Lignite; distillation products from	646	Lubricating oils; coefficient of expansion	270
— in Saxony	603	— cold test of	853
— tar oils; acid treatment of	646, 651	— apparatus for	855
— — estimation of hydrocarbons in	654	— colour	813
— — refining	650	— compound	874
— — refining of	649	— correction of specific gravity of, for temperature	273
(See also Brown Coal.)		— demulsification value of turbine	855
Ligroin; distillation of	br. 6482	— determination of the colour of	813
(See also Benzine.)		— of flashing-point of	br. 94
Lima district, Ohio; oil-fields of the	br. 2573	— of flashing-point and fire test	814
— petroleum	br. 7676	— of Gray's tester	816
Limagne, France; petroleum deposits at	47	— of Pinsky-Martens tester	814
Lima-Indiana field; production, value, and price of oil at the	1070	— of Pensky's-tester	814
Lime; uses of slaked as substitute for caustic soda at Baku	559	— of Treumann's tester	817
Limestone; bituminous	br. 7211	— of U.S. fire test	818
— production in France	1130	— distillates	519
Limestones; derivation of petroleum from	353	— distillation	505
— natural gas from Trenton and Clinton	107, 108	— effect of heat on	br. 8495
— petroleum and gas in Trenton and Clinton	br. 5810	— Elsass (Alsace)	571
— as reservoir-rocks	161	— Elsass-Lothringen Railway	860
Limmer asphalt	br. 3436, 6631	— evaporation tests	818
— — rock; composition of	335	— expansion of	269, 270
Linton; asphalt analysis	881	— exports of, from the U.S.	1069
Lisenko, K., and A. Stepanoff; alkali test for Russian petroleum products	870	— 1903-1918	1075-1078
Litharge in oil refining	517	— French	598
Liverpool; discharge and storage of oil at	716	— friction tests for	819, 842
Livonia; petroliferous deposits in	200	— — testers, Bailey	849
Loading-rack for charging tank cars	668, 671	— — Bouit	851
Loanda, Benguela, and Rossamedes; import duties on petroleum products	1143	— — Deprez and Napoli	848
Lobitos oil-field, Peru	150	— — Duske	847
Lobsann asphalt-rock; composition of	334	— — France	850
— (general)	br. 1192, 1615, 1682, 1827, 2231, 3290, 4355, 8723	— — Ingram and Stapfer	857
Locomotive burners	945, 949	— — MacNaught	847
Locomotives; license for keeping petroleum for light	1001	— — Thurston	849
— oil-burning	945-947	— — Woodbury	847
— regulations for keeping and use of petroleum for	988, 991	— testing of	842
— use of oil in	br. 1838, 2315, 2446, 2447, 2809, 2945, 4053, 4904, 6804, 6806, 7398, 7407, 7512, 7853, 7908, 7911-7915, 7983	— general characteristics of	273
Lombardia	br. 762, 763	— German	857
London County Council; petroleum licenses given by the	911	— railway specifications for	858
London; discharge and storage of oil in	795	— Hessian Railway	858
— petroleum licenses	994-1002	— import duties on, in various countries	1132 et seq.
Loristan petroleum deposits, Persia	53	— imports and exports of, into and from	1081-1083
"Lorne" burner; Rowatt's	892	— Austria-Hungary	340
Lorraine (see Alsace-Lorraine and Elsass-Lothringen).	178, 180, 182	— iodine absorption of	340
— oil-springs of	182	— Main-Neckar Railway	858
Los Angeles; oil industry of	br. 456, 773	— manufacture of	br. 101, 184, 209, 210, 622, 623, 626, 980, 1072, 1999, 2286, 2304, 2990, 3947, 4243, 4724, 4810, 5913, 6108, 6257, 6296, 6338, 6445, 6706, 6707, 6896, 7976
— wells of	122	— — of in a Baku refinery	520
— storage and testing regulations	1050	— neutrality test of	875
Lothringen (now Lorraine); oil springs of	182	— Palatinate Railway	859
Louisiana crude petroleum; specific gravity and flashing-point of	261	— physical properties of various	293
— distribution of oil-fields in	234	— preparation of, in the U.S.	542, 543
— gas production	114	— proportion of, in various crude oils	284-286
— petroleum and natural gas in	br. 1669, 3087, 3090, 3091, 3092, 3350, 3351, 3354	— Prussian railways	857
— production in	1066	— purification of	512, 513
— storage, inspection, and testing regulations in	1053	— in Rumania; production and consumption of	1084-1086
Lovibond's tintometer	813	— Russian	520
Low carburetted water-gas process	927	— Saxon railways	859
Lowe, T. S. C.; oil-gas manufacture; process of	928	— stills for making, Russia	482-484
Lower field; Pennsylvania and New York	101	— testing	br. 280, 392, 925, 1011, 1734, 1942, 1959, 2059, 2300, 2605, 2606, 2845, 3442, 3451, 3454, 3458, 3462, 3464, 3465, 3469, 3470, 3476, 4286, 4287, 4289, 4290, 4518, 4616, 5034, 5085, 5102, 5107, 5284, 5788, 6367, 6912, 7273, 7364, 7367, 7429, 7443, 7737, 7865, 7866, 7898, 8397, 8483, 8674, 8790
Lowering tools into a well	391	— vacuum distillation of	742, 813
Lubricants; characters of efficient	846	— value of the viscosity test of	842
Lubricating oils; adhesion	295	— viscosity of	295, 819
— alkali test for	870	— volatility test of	818
— Baden railways	857	— Wurttemberg railways	859
— from Baku	556	(general)	br. 67, 116, 117, 119, 281, 790, 986, 1286, 1321, 1419, 1578, 1638, 1806, 1964, 2108, 2147, 2982, 3004, 3005, 3074, 3486, 3489, 3621, 3975, 3991, 4013, 4072, 4073, 4074, 4079, 4084, 4087, 4095, 4096, 4239, 4244, 4285, 4288, 4393, 4503, 4627, 4740, 4882, 4919, 5468, 5528, 5797, 5828, 5837, 5838, 6051, 6435, 6468, 6860, 6871, 6912, 7111, 7824, 7825, 7957, 8021, 8144, 8187, 8207, 8209, 8269, 8674
— from Burma; properties of	264		
— in Canadian refineries; production of	1092		
— carbonisation constant for	818		
— chemical tests of	877		

	PAGE		PAGE
Lubricating value of oils .....	819	Maple Shade well, U.S.A. ....	89
Lubrication of engines; deposits resulting from the petroleum products for .....	818	Maps; oil .....	<i>br.</i> 3764
— (general) .... <i>br.</i> 184, 281, 316, 389, 579, 598, 1637, 1773, 1796, 2860, 4860, 4882, 5371, 5399, 6818, 7157, 7663, 7736, 8309	881	Maquette on petroleum inorganic formation .....	349
Lucas well, Texas; drilling record of the .....	403	Marbela manjak mine .....	<i>br.</i> 2976, 2977
Lucerne; petroleum regulations in .....	1049	Marcusson, J.; on lubricating power of mineral oil .....	341
Lucaire; flash-point tester .....	801	<i>Maria Lee</i> ; explosion on the ship .....	697
Lucigen lamp .....	907, 908	Marine boilers .....	<i>br.</i> 692, 1089, 1376, 8738
Lineberg Forest .....	<i>br.</i> 3010, 3011	— engines .....	<i>br.</i> 169, 738, 1559, 1713, 3535, 4524, 5213, 5317, 5318, 5886, 7506, 7723, 7724, 7763, 8281
Lugo's distilling apparatus .....	87	— organisms; origin of petroleum from .....	353
Luminosity; acetylene theory of .....	<i>br.</i> 4626	— theories of formation of petroleum from .....	360
Lux; mineral oils; detection of fixed oils in .....	875	— vegetable matter; theory of formation of petroleum from .....	359
<i>Luz</i> ; explosion on the s.s. ....	698	Markownikow, W., and W. Oglobin; coefficient of expansion calculated from density .....	268
Lyle and Hannay's Lucigen lamp .....	907, 908	Marmaros .... <i>br.</i> 2587, 2588, 3597, 5747, 6219, 6934, 7106, 7108, 7554, 7742	268
Lyman, Japan; methods of producing petroleum in .....	365	Martell, B.; tank steamers .....	683
MABERY, C. F.; bromine absorption of California petroleum .....	326	Martens' viscometer; modification of the Engler-Kinkler .....	834
— hydrocarbons from California petroleum .....	314	Martin oil furnace .....	<i>br.</i> 7508
— from Canadian petroleum and their chlorides .....	313	Martinique; import duties on mineral oils .....	1143
— from Pennsylvania petroleum .....	313	Marvin; Russian petroleum fields, description of ..	3
— paraffins from Pennsylvania petroleum .....	312	Maryland .....	226
— saturated hydrocarbons; properties of .....	317	— storage and testing regulations in .....	1053
— solid hydrocarbons of Pennsylvania oils .....	327	Mason's viscometer .....	822
— sulphur in petroleum; determination of .....	874	Massachusetts; storage and testing regulations in	1053
— vaseline; composition of .....	326	Mastic; asphalt .....	<i>br.</i> 4613
— and A. H. Goldstein; specific heat and latent heat of petroleum hydrocarbons .....	277	Masut; Russian .. <i>br.</i> 3966, 4273, 6677, 7244, 8356, 300, 498	336
— and Palm; hydrocarbons from Ohio Petroleum ..	313	Matthews, J. A.; carbides, decomposition of the, by water .....	349
— and Quayle; sulphur compounds from Canadian petroleum .....	301, 302	Maumené test of oils .....	<i>br.</i> 7519
Macalpine, T.; refining process .....	518	Mauritius; import duties on petroleum products ..	1143
MacCourt, C. D.; see Bone, W. A. ....	1318	— Petroleum Ordinances .....	1058
McCutcheon; paraffin-testing press .....	863, 864	Maxim carburetors .....	916, 917
McGee, W. J.; gas pressure in the Indiana wells ..	171	— and Sedgwick's carburetor .....	916, 917
Machine oil for the Palatinate Railway; specification for .....	850	Mecca-Belden pool, Ohio; lubricating oil from ...	105
Macholle; petroleum deposits at .....	47	Melanaphalt .....	<i>br.</i> 8294
M'Ilhiney, P. C.; resin oil in mineral oil, determination of .....	876	Mellite .....	<i>br.</i> 5198
Mackenzie, Canada; distribution of petroleum deposits in .....	218	Melting-point; determination of .....	<i>br.</i> 1829, 3051, 4745, 7292, 8295, 8405
M'Kittrick district, California; petroleum deposits of the .....	120	— of paraffin; estimation of the .....	866
MacNaught; lubricant tester .....	847	Memphis, Tenn.; storage regulations in .....	1060
Madagascar; import duties on petroleum products — occurrence of petroleum in .....	1143, 252	Menat oil-shales .....	<i>br.</i> 942, 4522
Madeira; petroleum in .....	<i>br.</i> 50	Mendeleëff; petroleum, theory of inorganic origin of .....	349, 359
Madill oil pool, Oklahoma .....	<i>br.</i> 7573	Menhaden oil; production of a petroleum-like distillate from .....	257
Madison, Wis.; storage regulations in .....	1060	Mercaptans .....	802
Mahler bomb calorimeter .....	751	Meriden, Conn.; storage and testing regulations ..	1051
Maidan-i-Naphthan oil-field .....	53	Mersey Docks and Harbour Board bylaws as to petroleum .....	1006
Maikop oil-field .....	<i>br.</i> 487, 3142-3147, 3150, 3152, 3155, 3159, 3181, 3162, 3524, 4212, 4307, 5453, 5663, 6263, 6388, 7402, 7675, 7697, 8421, 8576	Merz ozokerite extractor .....	565, 566
— historical account .....	13	Mesitylene .....	<i>br.</i> 2058
— pipe line .....	676	— in petroleum .....	315
Main-Neckar Railway; lubricating oil specification .....	858	Mesopotamia .....	<i>br.</i> 1314, 3411, 5160, 7154, 7155
Maine; storage and testing regulations in .....	1053	— oil deposits .....	55
Makarov's lamp for heavy oils .....	897	— method of collecting .....	54, 187
Makum, Assam; petroleum deposits at .....	59	— petroleum deposits in .....	<i>br.</i> 2830
Malay Peninsula; distribution of petroleum in the Malay States Enactment and Petroleum Rules ..	1037	Metal polish; flash-point test of liquid .....	518
Malinrat; petroleum deposits at .....	47	Metallic chlorides .....	944
Malta; import duty on petroleum in .....	1143	Metallurgical furnaces; use of oil-firing for .....	<i>br.</i> 3801
— Petroleum Ordinances of .....	1038	— oil forces .....	<i>br.</i> 345, 2960,
Maltha or mineral pitch .....	124, 255	Metallurgy; use of petroleum in .....	<i>br.</i> 350, 4271, 2054, 2099, 2396, 3913, 4876
Manchuria petroleum .....	<i>br.</i> 3796	Metals; action of petroleum on .....	<i>br.</i> 6857
Mandrel socket .....	383, 384	— rust proofing .....	311
Manhole fittings for storage tanks .....	677	Methane .....	349
"Manifold" well .....	164	— formation of, from carbides .....	<i>br.</i> 5773
Manitoba; distribution of petroleum in .....	218	— of, in nature .....	321
Manitowlin Island; specific gravity of crude petroleum from .....	259	Methyl propane .....	278
Manjak; Barbados .....	247	Methylene hydrocarbons; specific heats of .....	320
— exports from Barbados .....	1121	Methylpentamethylene in Caucasus petroleum spirit .....	<i>br.</i> 320
— Marbela .....	<i>br.</i> 2976, 2977	Mexican Eagle Oil Company .....	132, 134
— production in Trinidad .....	1125	— oil companies .....	131-136
— Trinidad .....	<i>br.</i> 2976, 2977, 3276, 6426	— Petroleum Company .....	131
Mannington oil-field .....	103	Mexico; asphalt exports from, 1898-1912 .....	123
Mann's flash-point tester .....	806	— distribution of petroleum in .....	245
Mansfield oil-gas producer .....	922	— fleet .....	138
		— import duties on mineral oils, etc. ....	1144
		— oil-burning locomotives in .....	180
		— oil-fields of .....	136
		— pipe-lines .....	136

	PAGE		PAGE
Mexico production of crude oil and imports of American products in .....	1088	Minnesota; distribution of petroleum and gas in ..	233
— refineries .....	137	— natural gas in .....	127
— southern fields .....	135	— storage and testing regulations in .....	br. 8419 10 4
— specific gravity and flashing-point of crude petroleum of .....	262	Mississippi test-wells .....	127
— statistics .....	138	Missouri; distribution of oil- and gas-fields of ..	231
— tankage .....	138	— oil and natural gas in .....	126
— transport and distribution of petroleum in ..	673	— petroleum production in .....	1066
— (general) .. br. 81, 477, 931, 1118, 1603, 1730, 2255, 3537, 3556, 3742, 4566, 4950, 5018, 5236, 5787, 7198, 7484, 8017-8109, 8480, 8797		— storage and testing regulations in .....	1054
Meyer, V.; flash-point, method of determining ..	796	— (general) .. br. 1032-1034, 6609, 7103	
Mezohegyes gas-spring .....	br. 5700	"Mitrailleuse" burner .....	893, 894
Miano di Medesano petroleum territory .....	31	Mixer .....	431
Michigan; distribution of petroleum and gas in ..	232	Mixing oils .....	874
— natural gas in .....	127	"Mixing" oils; refining, in Russia .....	58
— petroleum testing in .....	1054	Mixtures, testing petroleum .....	77
— (general) .. br. 376, 3875, 3876, 4418-4421, 8409, 8410		Modena petroleum; historical .....	31
Mid-Continent oil-field .. br. 3178, 3179, 3623, 3765, 3767		— petroleum in .....	br. 288, 825
— U.S.A.; development of the .....	110	Moeara Ewin Company .....	70
— production, value, and price of oil in the, 1917-1918 .....	1070	Moelsi Ilir Petroleum Company .....	70
Middle field, Pennsylvania and New York .....	99	Mogalki, India; oil deposits near .....	58
Middlesbrough; composition of natural gas from Middletonite .....	br. 2034, 3773	Moluccas; occurrences of petroleum at .....	217
Midway oil-field, California .....	120	Montan wax .. br. 807, 979, 1980, 2815, 4794, 4795, 6923	
Millspangh flash-point tester .....	805	<i>Mons Petrolius</i> .....	49
Milwaukee; storage and testing regulations in ..	1060	Montana; distribution of petroliferous deposits in ..	239
Minbu oil-field, Burma .....	62	— petroleum shale in .....	127
Mineral colza or sperm oil; testing .....	545, 742	— storage and testing regulations in .....	1054
"Mineral" gamboge .....	155	Monte Chiaro .....	br. 8721 31
Mineral india rubber .....	39, 176	Montechino; petroleum of .....	br. 928 31, 32
— oil formation; hypotheses of .....	br. 92	Montserrat; import duties on petroleum and products in .....	1144
— lamps .....	889	— Petroleum Ordinance, 1892 .....	1038
— stills; recovery of waste from .. br. 3258		Moor-coal .....	643
— works .. br. 1509		Moravia; petroleum in .. br. 6270	
— oils; action of light on .. br. 2861, 5830		— petroliferous deposits in .....	194
— artificial .. br. 7011		Morgan-Prown; petroleum, solidification of .....	885
— asphaltic constituents of .. br. 5269, 5270		Morocco; import duty on petroleum in .....	1144
— decolorising, by fuller's earth .....	526-528	— specific gravity and flashing-point of crude petroleum from .....	265
— desulphurisation of .....	525	Motor boats .. br. 64, 1576, 1898, 5194, 5457, 5956, 7341, 7518, 7931	
— detection and determination of rosin oil in ..	876	— cars and motor boats; engines of .....	975
— and estimation of fixed oils in .....	875	— launches; Thames Conservancy byelaws for petrol .....	1152
— determination of, in rosin oils .. br. 66, 3055		— spirit; supply of .. br. 4721	
— effect of heat on .. br. 6972, 8206		— spirits; specific heats of some .....	279
— emulsification of .. br. 3806		— vehicles .. br. 538-543, 4733, 6626, 6672, 8328	
— in fats, etc.; estimation of .. br. 3536, 6505		Motors (general) .. br. 522-524, 605, 638, 828, 1056, 1181, 1220, 1552, 1636, 1684, 1763- 1768, 1813, 1816, 2190, 2434, 2638, 2924, 2968, 2993, 3009, 3039, 3107, 3108, 3356, 3501, 3531, 4124, 4128, 4312, 4316, 4331, 4332, 4399, 4406, 4407, 4477, 4614, 4665, 4763, 5358, 5386, 5387, 6017, 6539, 6614- 6616, 6743, 7205, 7342, 7463, 7529, 8000, 8212, 8256, 8328, 8341, 8463, 8780	
— gases yielded by various .....	924	"Mountain fats" .....	889
— import duties on, in various countries ..	1132 et seq	Mountgerald, Scotland; bituminous material from .. br. 4924	
— lowering the flash-point of .. br. 470		Mouse-trap .....	385
— optical activity of .. br. 129, 5036, 5037, 5040, 5042, 5510, 5946, 7870, 7872, 7873, 8129, 8634, 8639		Mozambique; import duties on petroleum products in .....	1144
— oxidation of .. br. 7382		Mud-volcanos .. br. 21, 24, 25, 33, 45, 133, 257, 645, 914, 1043, 1840, 1963, 2256, 2267, 2656, 2899, 4298, 4990, 4992-4996, 5197, 5400, 6226, 6345, 7036, 7053, 7072, 7112, 7181, 7183, 7184, 7187, 7192, 7200, 7210, 7642, 7970	
— reaction of .. br. 7005		— with petroleum; association of .....	172
— refining .. br. 5138, 6032, 7009, 7010, 7012, 8438		Muller's "Alpha" gas-making machine .....	915
— rendering soluble .. br. 8619		Mumia .. br. 1447, 200, 256	
— resinification of .. br. 93		Mummy .....	187
— Scottish methods of testing .....	804	Mungal shale .....	609
— separation of, from turpentine and resin oil .. br. 3381		Murindo .. br. 5303	
— of the resinous constituents of .. br. 1584		Murrayville gas-field, Pa. ....	429
— of sulphur from .. br. 3223, 4803		Muscogee oil-field .. br. 7574	
— solubility of, in alcohol .. br. 95		Musjid-i-Suleiman oil-springs .....	53
— of, in benzol .. br. 600		NACODOCES oil-field .. br. 1879	
— testing .. br. 98, 3491, 3500, 4519, 6477, 7380-7382, 7927		Namrup River; petroleum on the .. br. 740	
— testing, for animal and vegetable oils ..	br. 3054	Namchuk Pather; petroleum at .....	59
— the value of, for gas making ..	br. 3230	"Naphtha Bank" .....	206
— viscosity of American and Russian, com- pared with water and other oils ..	295	Naphtha; bromine test of .....	868
— (general) .. br. 96, 115, 132, 388, 599, 1083, 1965, 2550, 3834, 4951, 5330, 5333, 5380, 5780, 6467, 6881		— in Canadian refineries; production of ..	555
— seal oil .....	937	— in coal .. br. 5501	
— sperm oil .. 545, 742		— decomposition products of .. br. 3941	
Mining oil-shale in Scotland .....	610	— determination of, in petroleum .. br. 940	
— petroleum .. br. 145-149, 798			
— Russian regulations .....	1042		

	PAGE		PAGE
Naphtha distillates; refining	br. 4707	Newfoundland oil-shale	606
— distillation of	br. 3195, 3372, 6335, 6336	— petroleum deposits in	84
— in the United States	539	— production of crude oil in	1096
— distilling plant	502, 539, 542	— specific gravities of crude petroleum from	259
— of Monte Chiaro, Italy	31	— (general)	br. 1338, 1434, 2803
— oil-gas yielded by mineral	925	New Guinea; distribution of petroleum in	217
— residues; distillation of alkaline	br. 4653	— oil in	156
— shale	br. 7379, 7660, 8381	— Papua fields	254
— soap tests	776	— crude oil examinations	291
— stills; Heckmann's	502-505	New Hampshire; storage and testing of petroleum in	1055
— testing	br. 1635, 3963	Newhaven, Conn.; storage and testing regulations	1051
— treatment	637	New Jersey; distribution of petroliferous deposits in	223
— (general)	br. 1451, 2974, 7849, 7856, 7907, 8098, 8381, 8382	— petroleum in	127
Naphthalene	309, 318, 319, 654	— storage and testing regulations	1055
— in crude petroleum; presence of	319	New Mexico; distribution of the oil and gas deposits in	240
Naphthas; American	540	— oil and natural-gas in	125
— exports of, U.S., 1903-1918	1075	— testing regulations	1055
— import duties on, in various countries	1132 <i>et seq.</i>	New Orleans; storage and testing regulations	1053
— "Naphtéine"	br. 1750	New Plymouth, N.Z.; petroleum deposits at	153
Naphthene hydrocarbons in petroleum	316	Newry pitchstone	br. 4142
Naphthenes	br. 285, 318, 321, 322, 1062, 2106, 4011, 4971, 5061, 5065, 6129, 6305, 6716, 6767, 7207, 7294, 8443, 8447, 8647-8654, 8659-8661	New South Wales	br. 699, 701, 705, 708, 709, 746, 1247-1250, 1371, 1374, 1641, 3878, 4726, 4728, 6608, 8741
Naphthenic acids	br. 123, 285, 317, 322, 323, 1324, 1325, 2466, 3232, 3233, 3919, 3923, 4003, 4009, 4012, 4021, 5059, 5063, 5064, 7007, 7207, 8589, 8590, 8594, 8602	— kerosene shale produced in, 1865-1909	1130
— — utilisation of	514	— shales of	604, 605
Naphthometers; Parrish	801	— occurrence of petroliferous deposits in	253
— Parrish-Engler	801	New York City; explosion on the steamer	701
Naphtnia Gora, Transcaspien	16	New York State; distribution of petroleum in	223
Naphtion Island	16	— geology of	br. 548, 550, 551, 759, 1239, 1240, 1245, 3049, 6276-6279, 7945, 7946
Narragansett, tank steamer	686	— natural gas in	br. 340, 341, 757, 758, 1926, 1927, 5814, 8920, 8522
Nasmyth's apparatus	819	— — oil-fields of	99
Natal; petroleum regulations in	1058	— oil production in	102
National Transit Co.'s pipe-lines	661	— petroleum in	br. 337, 341, 757, 758, 5814, 7940, 7941, 8515
Napier's viscometers	822	— — — production in	1066-1068, 1071
Naples; petroleum storage regulations	1034	— pipe-lines	657
Napoli, <i>see</i> Deprez	848	— record of the natural-gas industry in, 1897-1918	1106
Nasmyth's viscometer	819	— storage and setting regulations	1055
Natural-gas gasoline marketed in California, 1912-1918	1119	— Produce Exchange rules for crude petroleum	744
— — in Illinois, 1914-1918	1119	— — — for kerosene	755
— — in Kansas, 1916-1918	1120	New Zealand; bituminous shales of	604
— — in Kentucky, 1916-1918	1120	— geology of	br. 548, 4727, 5369, 5370
— — in Louisiana, 1916-1918	1120	— import duties on petroleum products in	1145
— — in Oklahoma, 1911-1918	1117	— Kotuku, output of petroleum	155
— — in Ohio, 1911-1918	1118	— oil-shales	br. 1893
— — in Pennsylvania, 1911-1918	1118	— output and value of oil-shale in	1131
— — in Texas, 1916-1918	1120	— petroleum in	br. 587, 990, 1151, 3213, 3268, 4918, 5881, 6534, 6649, 7199
— — in the U.S., 1911-1918	1113	— — and natural gas in	152
— — in W. Virginia, 1911-1918	1117	— Petroleum Ordinances and Acts	1040
— — production of, 1916-1918	1114-1116	— specific gravity and flashing-point of crude petroleum from	266
Nebraska	br. 455	N'hangelite	br. 899, 6463
— occurrences of petroleum in	238	Nicaragua; import duties on petroleum products, etc.	1145
— petroleum testing regulations	1054	Niddrie Castle oil works	br. 7234
Nederlandsch-Indische Industrie en Handel Maatsch	70	Niger Territories; import duties on petroleum products	1145
Neftedegil	br. 3300	Nigeria; occurrence of petroleum in	157
Negritos oil-field, Peru	149	— Petroleum Ordinance (1889) of Southern	1040
Nenndorf	br. 6978-6980	Niitzu oil-field, Japan	74, 75
Neutrality of mineral oils; testing the	756, 875	Nishigama oil-field, Japan	74, 75
Nevada; occurrences of petroleum in	242	Nitric acid; formation of, in the Brünler firing system	964
— oil deposit in	129	Nitrogen in bitumens	300
— (general)	br. 196-198, 4905	— in gas; determination of	br. 6072
Neviano de' Rossi petroleum	34	— in petroleum; percentage of	300
Nevis; import duties on petroleum products	1144	Nitrogenous constituents of petroleum oils	br. 570, 572, 3928, 3986, 4028, 6895
Newark, N. J.; testing regulations of	1055	Nitronaphthalene; detection of, in mineral oils	br. 4570
Newberry, J. S.; petroleum, theory of organic origin of	354	Nobel, L.; steam generation in stationary boilers	949
New Brunswick; distribution of petroleum and gas in	220	Nobel Bros.; Baku refinery	557
— natural gas in	82	— — system of continuous distillation at Baku	558
— petroleum deposits in	81	— — of oil storage in Russia	677
— Petroleum Storage Act	1039	Noeltling, F., Burma; methods of obtaining petroleum in	369
— shale deposits of	606	Noene	311
— specific gravity of crude petroleum from	259	Nonocosane	328
— (general)	br. 401-403, 405-407, 2013, 2016, 2017, 2020, 2021, 2025, 3368, 3697, 6196, 7615, 7616	Nonodecane	313
New Caledonia; import duties on petroleum products	1145	Norcross; explosion on the ship	701
Newfoundland; distribution of petroleum in	221		
— import duties on petroleum products	1144		
— Kerosene Act and Inflammable Oils Acts	1139		

	PAGE		PAGE
North Borneo; Explosive and Combustible Sub- stance Storage Proclamation	1040	Oil-gas made by the Peebles plant	930
North Carolina; distribution of petroleum de- posits in	226	— manufacture of	921
— testing petroleum in	1056	— oxygenated	br. 7720
North Dakota; natural gas in	br. 4569	— plant	921-927
— testing petroleum in	1056	— production; Tocher's experiments on	931, 932
Northwich; occurrence of petroleum at	41	— for railway-carriage lighting	924
Norway; distribution of petroleum in	199	Oil and gas, separating	425
— import duties on mineral oils, etc.	1145	— lamps, <i>see</i> Lamps.	
Nova Scotia; distribution of petroleum and gas in	220	— lighthouse	742
— oil-coal of	br. 3553, 6197	— lines	166
— petroleum deposits in	81	— on fire on the sea	4
— shale deposits of	606	— "once-run"	627
OAKBANK oil-works; cooling process used at the	635	— production; cost of	br. 3749
Oakland City oil-field	br. 792	— properties; leases for in the U.S.	373
Ochsenius; petroleum, origin of	358	— valuation of	br. 5241, 8168
Octane	280, 311, 312	Oil-raising appliances	br. 7412
— heat of vaporisation of	280	— by compressed air	365
— oil-gas yielded by	926	Oil reservoir-rocks	161
— specific heat of	277	Oil-saver	392, 393
Octanes in American petroleum	br. 4856	Oil-shale in New Zealand; output and value of	1131
Octococane	313-	— output in Great Britain	1128, 1129
Octodecane	311, 313	— properties of	591
Octonaphthene from Rumanian oil	316	— and the production of oil	96
Odin Mine, Derbyshire; elaterite in	39	— in the United Kingdom; output and value of	1127
Odour of crude petroleum	257	( <i>See also under</i> Shale.)	
— of kerosene; determination of the	762	Oil; skimming from surface of water	65
Oedemissen tar-wells	br. 5875	— solar	757
Oelheim oil-field, Prussia	37	Oil Springs field of Canada	77
— petroleum industry	br. 4103, 4425, 5146, 5640, 6864	Oil-steamers; cleaning bulk, for receiving grain, etc.	694
— residuum; fractionating apparatus for	571, 576	Oil-stoves	br. 441, 4537, 6128
— products from	572, 576	Oil-strata; capacity of	162
Oglobin, V.; benzene and its homologues from Russian petroleum; preparation of	538	— protection of	br. 361
— <i>see</i> Markownikow, W.	268	Oil striking	br. 7216
Ohio; composition of natural gas from	345	— structural conditions affecting accumulation of	164
— crude petroleum; specific gravities of	260	— supplies; duration of the	172
— distribution of the oil- and gas-fields in	229	— tank gauges	677
— gas-wells of	429	— under the sea	206
— natural gas in	br. 4115, 5583, 5586, 5703, 5704, 5706-5708, 8535	Oil-well; abandonment	421
— — — industry, 1897-1900; record of the	107	— casing	416-418
— petroleum	br. 4836, 4838, 4861, 5009, 5578, 5579	— production in U.S.	420
— petroleum deposits in	br. 888, 910, 963- 966, 968, 969, 3347-3349, 5582, 5585, 5798-5808	— torpedoes	425-428
— — and hydrocarbons	105	— waste disposal	br. 961
— — production in	1066	Oil-wells in the Baku field; number and condition of	1080
— pipe-lines in	661	— cement lining	br. 871, 1712
— rock section, Cleveland gas-field	230	— drawing supplies from surrounding districts	163
— — Woodsfield quadrangle	231	— of the Grozni field; particulars of the	1081
— storage and testing regulations	1056	— plugging	br. 8568, 8792
Ohio-Indiana petroleum; hydrocarbons of	318	— pressure in, and its cause	169, 170
Ohlungen wells; petroleum from the	46	— water, excluding, cementing process	408
Oil; arrangement for separating, from gas	425	— working Galician	br. 1060
— "belt" hypothesis; the	167	Oils; analyses from different seams	594, 595
Oil-burning locomotives	945-951	— calorific value, Diesel engine	275
Oil carried in double bottom of a ship	689	— — of heavy fuel	274
Oil City Boiler Works' burner	953, 954	— — kerosenes	275
— companies	br. 363	— — petrols	275
— — Scottish	590	— crude, various, examination of	292, 293
— consumption of by lamps	897, 898, 899	— from various shales	592
Oil-cooling apparatus for paraffin production	633-637	— detection and estimation of fixed, in com- pound oils	874
Oil Creek, Pa., U.S.A.; petroleum at	85, 88	— products yielded by various	925
Oil destroyed in war	23	— U.S. Fuel Administration, specifications	755
— engines, <i>see</i> Engines.		Ojiya oil-field, Japan	75
— extraction processes	br. 5199, 5200	Oklahoma; distribution of the oil deposits in	235
Oil-fields; organisation of, Davson's system	474	— natural-gas industry of	112
— the principal, of Rumania	30	— petroleum industry in	112
— of the U.S.; principal	99	— production in	1066
Oil fire-test	763	— record of the natural-gas industry in, 1906- 1918	1108
Oil; in fissures and pockets	167	— testing petroleum in	1057
— fluorescence	72, 153, 542	— (general)	br. 2726-2730, 3624, 7217, 7572, 7573, 8461
Oil-fuel; Admiralty specification	940, 941	Okonite	563
— advantages	943	Olefines; formation of	br. 1074 305, 314
— system; pumping, testing, and straining unit installed in the Wallsend-Howden system	961	— in petroleum	314
— used industrially	944	— in shale and petroleum products	br. 161
— v. coal	942	Oleins; formation of a substance resembling petroleum from	357
Oil-gas	921	Oleuda oil-field, California	br. 1997
— burning	921	Oleomargarine; adulteration of, with paraffin	br. 2564
— and coal-gas; properties of mixtures of	921	—	br. 3199
— compressed	br. 379	Oleum asphalti; medicinal uses of	61
		<i>Oleum Terrae</i>	
		Oilphant, F. H.; gas-wells; pumping and com- pressing engines for use with	431
		— natural gas-fields of Kansas	111

	PAGE		PAGE
Oliphant, F. H.; production of natural gas in the U.S.	932	Panay islands	br. 16
Omnibuses; motor	br. 5055	Paper-coal	643
Ontario; distribution of petroleum in	218	— products of distillation of	648
— natural-gas composition	82	Pappel, A.; yields of products from Egyptian crude petroleum	291
— industry of	344	Paraffin; analysis of	br. 1783
— statistics of natural gas production in, 1902-1918	1111	— Austria-Hungary imports and exports	1082
— (general)	br. 821, 8194, 4127, 5311	— from Boghead coal	328
Optical activity	298	— bromine test of waxes	868
Oran, Algeria	br. 2156, 3757, 5551, 5554, 5565	— from brown-coal tar	br. 975, 976, 4670
Orange county, California; oil-wells in	123	— candles	883
Orange River Colony; occurrences of petroliferous deposits in	252	— chemical properties of	255
— oil indications in	158	— composition of	br. 204, 2866, 4641, 4848, 7726
— petroleum in	br. 3882, 6896	— cooling apparatus for producing	633-637
Orde burner	952, 953	— in crude petroleum	br. 1593, 3371, 5391, 5902, 6383, 310-314
Ordway, J. M.; lubricating oil tests	845	— determination of	br. 636, 1978, 2078, 2326, 3334, 3387, 3427, 3428, 3469, 3472, 3474, 3476, 3495, 3537, 3914, 4260, 5049, 5938, 5947, 7897, 8586
Ore concentration by oil	884	— of, in crude oil distillates	br. 97
— flotation	br. 904, 6648	— of dirt in	864
— roasting	br. 8373	— of the melting-point of	br. 481, 2308, 2738, 3576, 4069, 4071, 4075, 4081, 6994-6996, 7292, 7396
Oregon; gas and oil in	br. 8204, 8205	— of oil in	863
— occurrences of oil in	244	— of water in	br. 585
— storing and testing regulations	1057	— exports from Rumania	1084
Organic matter; stages in the formation of petroleum from	360	— extraction of	br. 571, 1015, 1073, 1900, 2932, 2933, 3574, 3575, 3701, 3834, 4010, 4120, 4164, 4866, 5261, 5262, 6204, 6310, 6881, 7884, 8100, 8266, 8633
Organisation of petroleum fields; Davsou's system of	474	— final treatment of	543
Orton, E.; asphalt-rocks; composition of French and German	334	— formation of	br. 5725
— Lima petroleum field in 1887	106	— (general)	br. 115, 1005, 1207, 2108, 2279, 2284, 2356, 2501, 2547, 2611, 2815, 3428, 3444, 4270, 5048, 5305, 5458, 5734, 5945, 6485-6488, 6495, 6496, 7423, 7782, 8039, 8056, 8061, 8064, 8540
— petroleum and gas-wells; geology of	161, 165, 170, 171, 172, 173	— and heavy oil redistillation	505
— petroleum; organic origin of	348, 353, 355	— history of the manufacture of	589
Osaka; petroleum regulations in	1036	— hydrocarbons in American and Canadian oils	313
Ostakli burners; Russian	951, 952	— in Pennsylvania petroleum	312, 313
— Russian	491, 951	— lamps for solid	910
— still, with dephlegmator	505-507	— mixer; Ramdohr	543
Ottawa; natural gas in	br. 185	— normal	br. 5665, 6956, 6960, 6961
Oued-Quarizane, Algeria; natural gas at	49	— oil from coal; crude	br. 5922
Oukhta, see Uchta		— poisonous effect of	br. 6834
Oxidising agents	518	— testing	br. 1845, 6446, 741, 755
Oxygen compounds in petroleum	322	— oils; manufacture of	br. 568, 599, 975, 2932, 5195, 7385
Ozokerite	562	— ointment	br. 5204, 5305
Ozokerite; composition of	330	— and paraffin candles; import duties on, in various countries	1132
— decolorising powder for refined	568	— in petroleum	311, 327
— exports from Austria	1082	— properties of	br. 878, 883, 1016, 1152, 3733, 3781, 5070, 6245
— extractors and filter presses for use in separating and refining	563-569	— purification of	br. 3003, 4107, 5306, 5459, 6408, 7661, 7973
— formation and distribution of	174	— refining by naphtha treatment	637
— industry; conditions and cost of working in the industry in Galicia	470, 23	— relation between specific gravity and melting-point	328
— manufacture of candle material from	561	— scale; crude	546
— mining in Galicia; primitive system of	470	— estimation of oil in	br. 813, 5376, 6449, 7514, 7710
— production in Austria and Russia; quantity and value of	1121	— production of	632
— properties of	330	— Scottish methods of analysis	864-867
— refining in Austria-Hungary	560	— separation of, American method	543
— residue; production of insulating material from	563	— specific gravity of	br. 110
— separation of, from the matrix	472	— sweating process for	637-641
— testing	743, 877	— testing	br. 1017, 2556, 4085, 6994-6996, 7161, 7174, 8262, 741, 862
— valuation of	877	— uses of	883
— in Western Caucasus	br. 134	— in vaseline distillates	527
— (general)	br. 137, 214, 385, 391, 580, 635, 637, 768, 829, 851, 978, 996, 1013, 1168, 1285, 1291, 1382, 1387, 1696, 2176, 2387, 2457, 2470, 2514, 2586, 2618, 2619, 2647, 2719, 2736, 2953, 3115, 3244, 3432, 3545, 3672, 3757, 3773, 3906, 4188, 4219, 4224, 4267, 4309, 4334, 4335, 4483, 4645, 4716, 4798, 4799, 4876, 4907, 4960, 4963, 4980, 5144, 5449, 5587, 5672, 5693, 5743, 5747, 5883, 5931, 5932, 6331, 6380, 6428, 6461, 6478, 6629, 6841-6846, 7375, 7665, 7919, 7955, 8258, 8296, 8352, 8425, 8468, 8524, 8583, 8584, 8631	327, 328, 328, 324	
Ozone	305, 842	— from Whitehaven colliery	br. 564, 1790
— and transformer oils	530	— works; Young's	br. 4801
Ozanna petroleum deposits	31	— from a Yorkshire seam	br. 1414
PACIFIC Coal and Iron Company	120	Paraffinum liquidum	530
Paints containing petroleum; testing flashing-point of	773	— refining	531
Palatine Railway (Germany); lubricating oil specifications	859	— molle (Brit. Pharm.)	326
Palestine	br. 787, 1562, 2032, 3571, 4439, 4440	Paraguay; import duties on petroleum products	1145
Panama; import duty on mineral oils	1145	Parianite	br. 5997
		Parker on rotary drilling	439
		Parrish-Engler "naphthometer"	801
		Parrish's "naphthometer"	801
		Parsons; purification of alcohol by paraffin	887



	PAGE		PAGE
Pavements; asphalt . . . . .	1117, 3841, 4806, 4999, 5701, 5984, 6250, 6549, 6556, 6987, 6988, 7761, 8776	Pescara valley; petroleum production in . . . . .	31, 35
Pawlewski and Pilemonowicz; estimation of solid hydrocarbons in mineral oils . . . . .	879	Petchora petroleum . . . . .	br. 874, 2675, 3071, 7625
Pease's electric flash-point tester . . . . .	794	<i>Patriana</i> ; explosion on the tank steamer . . . . .	697
Peat . . . . .	603	Petrocene . . . . .	br. 6787
— hydrocarbons of . . . . .	br. 1899	— hydrocarbons from . . . . .	325
— manufacture of oil from . . . . .	br. 5918, 8046, 8049, 8050	Petrolia (Canada) Oil Exchange rules for kerosene — oil-field . . . . .	756 77, 78
— theories of origin of petroleum from . . . . .	351	<i>Petrolia</i> ; explosion on s.s. . . . .	700
Pechebromm; composition of natural gas from . . . . .	346	Petroleum . . . . .	br. 5998, 6573
— petroleum, deposits of . . . . .	43	Petroleum; absorption of gases by . . . . .	br. 2655
— residuum; fractionating apparatus for . . . . .	576	— by wood and rocks . . . . .	br. 203
— products from . . . . .	571	— acids, <i>see</i> Naphthenic Acids. . . . .	
— (general) . . . . .	br. 4507, 4509, 5465	— Act, 1871 . . . . .	767
Peckham; nitrogen-content of Californian bitumen — origin of petroleum . . . . .	350, 354, 355	— 1879 . . . . .	985
Peebles gas plant . . . . .	930	— 1881 . . . . .	986
— process . . . . .	br. 8549, 8558	— action of formaldehyde on . . . . .	br. 5524, 5527, 5529
Pegu . . . . .	br. 7672-7674	— of aluminium-chloride on . . . . .	586
Pelekienka petroleum . . . . .	br. 6728	— Acts of Antigua . . . . .	1009
Penetrometer . . . . .	br. 2357, 6557	— of Australian Commonwealth . . . . .	1010
Pennsylvania crude oil; yield of products from . . . . .	540, 541	— of Austria . . . . .	1012
— petroleum; specific gravities of . . . . .	259	— of Barbados, Belgium, Bermuda . . . . .	1014
— distribution of petroleum in . . . . .	223-226	— of British Guiana, British Honduras . . . . .	1015
— driller's outfit . . . . .	379	— of Canada . . . . .	1016
— estimated volume of gas produced in 1916 . . . . .	103	— of Ceylon . . . . .	1016
— evolution of the present drilling system in . . . . .	393	— of Cyprus . . . . .	1017
— gas-wells in . . . . .	br. 338, 1252, 1834, 4595-4598, 5475, 5478-5481, 6527, 6779, 7087, 7221, 7265, 7433, 7437, 103, 429	— of Dominica and Fiji . . . . .	1018
— oil production in . . . . .	102	— of Falkland Islands . . . . .	1018
— oil regions . . . . .	br. 327-331, 333, 336-338, 888, 1087, 1141-1144, 1210-1213, 1238-1245, 1300-1303, 1350-1353, 1442, 2480, 2482, 2569, 2575, 2612, 3550, 4589, 4590, 5687, 6638, 6639	— of Gambia . . . . .	1023
— petroleum . . . . .	br. 493, 495, 939, 2538, 3270, 3313, 4838, 4843, 4847, 5475, 5478-5481, 6351, 6527, 6778, 6780, 7087, 7117, 7118, 7124, 7433, 7437, 7804, 8194, 8257, 8513-8515, 313, 339	— of India . . . . .	1032
— laws . . . . .	1057	— of Isle of Man . . . . .	1033
— paraffins from . . . . .	312, 313	— of Jamaica . . . . .	1035
— production in . . . . .	1066, 1068	— of New Brunswick . . . . .	1039
— specific heats of hydrocarbons from . . . . .	277	— of Newfoundland . . . . .	1039
— pipe-lines . . . . .	661	— of Norway . . . . .	1041
— record of the natural industry in, 1897-1918 . . . . .	1102	— affinity of clay for . . . . .	173
— Rock Oil Company . . . . .	87	— air-gas . . . . .	919, 920
— section of oil- and gas-sands . . . . .	224	— of America; the quality of the . . . . .	br. 111
Pensky flash-point tester for lubricating oils . . . . .	br. 3480, 3490, 814, 815	— analysis of . . . . .	br. 223, 1661, 2066, 2097, 5535, 5544, 5824, 5873, 5972, 5978, 6048
Pensky-Martens flash-point tester . . . . .	814, 815	— animal origin of . . . . .	355, 357, 358
Pentacosane . . . . .	313	— as fuel . . . . .	940
Pentadecane . . . . .	313	— association of mud-vulcanos with . . . . .	172
Pentane . . . . .	311, 314	— of salt with . . . . .	168
— evaporation of, by air-currents . . . . .	913, 915	— barges; Thames Conservancy rules as to . . . . .	1002-1005
— explosion of mixtures of, with air . . . . .	708	— barrels . . . . .	671, 672
Pentatricontane . . . . .	327	— benzenic hydrocarbons in . . . . .	315
Pentland shale retort and gas producer . . . . .	615, 616	— benzil (German Pharmacopœia) . . . . .	268
Peoria, Ill.; storage regulations . . . . .	1052	— boiling-points of crude . . . . .	280, 281
Perforator; Graham's casing . . . . .	406, 407	— Bounty Act of Canada . . . . .	1016
— "Perfumery" oils; refining, in Russia . . . . .	531	— Bristol Docks Committee regulations as to . . . . .	1006
— "Perpetual" lamps; Hampton's . . . . .	903	— British Acts relative to testing, storage, etc., of bromine absorption of crude . . . . .	979
Persia; Ahwaz-Pusht-i-Kuh region . . . . .	210	— and iodine values of . . . . .	br. 7925, 7926, 8255
— Bahrein Islands . . . . .	212	— butter . . . . .	br. 5561
— Bakhtiari country . . . . .	212	— calorific power of . . . . .	br. 121, 273, 274, 276, 947, 948
— crude-oil fractional distillation . . . . .	54	— from Campina; specific gravity of crude . . . . .	258
— distribution of petroleum in . . . . .	208-212	— chemical composition of . . . . .	299
— import duties on petroleum products . . . . .	1146	— nature of, from California . . . . .	319
— Maidan-i-Naftun oil-field . . . . .	618	— of, from Canada . . . . .	319
— Qishm Island and Persian Gulf region . . . . .	210	— chemistry of . . . . .	br. 2752, 2765, 2767, 2911, 2981, 3109, 3310, 3311
— specific gravity and flashing-point of crude petroleum from . . . . .	265, 266	— classification of . . . . .	br. 2926, 2928, 5999
— (general) . . . . .	br. 864, 2620, 3245, 3287, 3411, 4946, 5196, 6113, 6176, 6907, 6908, 7156, 7311, 7323, 7559, 7741, 7751, 8119, 8433	— of theories of organic origin . . . . .	347
Persian Gulf region . . . . .	210	— coefficient of expansion . . . . .	br. 6449
Peru; distribution of petroleum deposits in . . . . .	250	— coke . . . . .	br. 4430, 4648, 4654
— import duties on petroleum products . . . . .	1146	— combustion tests on engines . . . . .	972
— petroleum deposits . . . . .	br. 384, 510, 1348, 1625, 2523, 4422, 4761, 5139, 5388, 5708, 6177, 7695, 8263	— commercial products of crude . . . . .	284
— production of petroleum in . . . . .	1090	— composition of . . . . .	br. 820, 998, 3333, 3492, 3577, 4345, 4508, 4511, 4512, 4689, 4833-4851, 4868, 6399, 6556
— specific gravity and flashing-point of crude petroleum from . . . . .	262	— continuous distillation of, at Nobel Bros's Eaku refinery . . . . .	558
		— "cracking" . . . . .	br. 1409, 1817, 2635, 2636, 6253, 6849
		— decolorising and deodorising . . . . .	479, 577
		— deposits; locating . . . . .	br. 1512, 7216, 7374, 7509, 7632
		— derivatives of . . . . .	br. 1129, 7883
		— detection and determination of sulphur in . . . . .	br. 163, 366, 2285, 2443, 2444, 2665, 3530, 4651
		— deterioration of . . . . .	br. 4061
		— determination of ash from . . . . .	870
		— of the calorific value of crude . . . . .	750
		— of the colour of . . . . .	761

	PAGE		PAGE
Petroleum; determination of the flashing-point of	763	Petroleum; geographical and geological distribu-	
— of the specific gravity of crude	745	tion ( <i>continued</i> ):—	
— of water in	<i>br.</i> 1574, 2750, 3969, 4308, 5033, 6604	Sweden	199
— different names of petroleum substances	1	Switzerland	182
— diffusion of, through earth, clay, etc.	<i>br.</i> 1656, 1667, 2089, 2616, 3308	Thibet	214
— distillates; refractive indices of	297	Tunis	185
— Riche and Halphen test for	868	Turkestan, Eastern	214
— distillation	478	Turkish Empire	187
— residues; composition of	325	United States	221
— distribution of	655	West Indies	246
— early views on the nature of	255	Petroleum; geological and geographical distribu-	
— Eastern Archipelago; production of, 1900-1918	1083	tion	160
— from Egypt; products from crude	291	— geology of	<i>br.</i> 224, 225, 245, 252, 472, 473, 716, 735, 838, 839, 1159, 1354-1361, 1622- 1664, 3019, 3021, 3404, 3605, 3606, 4386, 4530, 5812, 6353, 7427, 7698, 7699, 7790
— electrical treatment of emulsified crude	413	— German regulations as to storage and use	
— engines, <i>see</i> Engines.		of	1023-1028
— estimation of solid hydrocarbons in	879	— in Germany; production and value of crude	1091
— ether; physical properties of	267	— in Greece; sale of	1029
— evaporation of crude, by dry air	912	— Grenada Inflammable Goods Ordinance	1030
— examination methods for chemical constituents	358	— in the Grozoi field; production of crude	1081
— explosion of air-gas	707	— Guernsey laws as to	1030
— explosions	696	— harbour of S. Sabbia, Austria; regulations of	1012
— exports of crude and refined from the U.S., 1892-1918	1075-1078	— hawking of, Act of 1881	986
— and imports, Austria and Austria-Hungary	1081	— in Hong Kong; Ordinances as to storage of	1032
— fields; Davson system of organisation	474	— in Hungary; production and value of crude, 1898-1909	1094
— flow of, in pipes	<i>br.</i> 2116	— hydrocarbons; effect of high temperatures on, <i>br.</i> 294, 295, 4668, 4669, 4701, 5925, 6285	
— formolite reaction	340	— of the Appalachian field	318
— fractional distillation of various kinds of	280-284	— evaporation of by air	912
— test for crude	746	— natural	<i>br.</i> 49
— precipitation of	<i>br.</i> 3963, 4024	— specific heat of	277
— fractions; coefficients of expansion of	269	— of various	278
— from Russian	556	— ignition point of	<i>br.</i> 356, 1007, 1096, 1905, 2093, 2877, 4720, 4732, 5149, 6014, 6050, 6319, 6678, 259, 763
— French decrees as to manufacture, storage, and sale of	1019-1023	— import duties on, in various countries	1132
— in Formosa; production of crude	1089	— increasing the illuminating value of	<i>br.</i> 7032
— in Galicia; production of crude	1082	— in India; production and value of crude	1087
— from Galicia; specific gravities of crude	263, 264	Petroleum industry; historical:—	
— Galician; deliveries of to refineries, 1907-1910	1083	Africa	157
— general distribution of	174	Algeria	48
Petroleum; geographical and geological distribu-		Australia	155
tion:—		Austria-Hungary	19
Afghanistan	212	Canada	76
Africa	251	Carpathian fields	19
Algeria	184	Central America	152
Annam	214	China	72
Arabia	186	Earliest references	1
Australia	253	Eastern Archipelago	67
Austria-Hungary	190	Egypt	49
Baluchistan	212	Farsan Islands	51
Belgium	182	Formosa	76
Bosnia and Herzegovina	189	France and Switzerland	43
British America	217	Germany	37
British India	212	Great Britain	38
British Islands	175	India	55
Carpathian fields	190	Italy and Sicily	31
China	214	Japan	74
Denmark	199	Mexico	130
Eastern Archipelago	215	Newfoundland	84
Egypt	185	New Guinea	156
France	178	New Zealand	152
Germany	195	Persia	51
Greece	188	Rumania	25
Greenland	221	Russia	3
Holland	182	South America	144
Honduras	346	Spain	47
Italy and Sicily	183, 184	Turkey	54
Japan	214	United States	85
Malay Peninsula	214	West Indies	138
Mexico	245	Zante	36
Morocco	185	Petroleum industry in Rumania; statistics of	1084-1086
Montenegro	189	— in the U.S.; development of	87
New Caledonia	254	— use of cold in the	<i>br.</i> 2927
New Guinea	254	— inorganic origin theories	348
New Zealand	254	— Isle of Man Acts and regulations as to	1033
Norway	199	— Italian regulations as to storage, etc., of	1034
Persia	208	— in Japan; productions of crude	1089
Portugal	177	— Japanese regulations	1035
Rumania	189	— lamps, <i>see under</i> Lamps.	
Russia	200	— laws of Holland	1031
— Asiatic	207	— licenses; L.C.C.	991-1001
Serbia	189	— in London, 1890; report on	991
Siam	214	— as locomotive fuel	945-951
South America	249		
Spain	177		
Spitzbergen	200		

Petroleum for locomotives, regulations for keeping and use of, 1907 . . . . . 988

— from marine organisms; summaries of theories of formation of . . . . . 359

— Mersey Docks and Harbour Board bye-laws as to Petroleum; methods of producing:—

  Burma . . . . . 369

  Canada . . . . . 432

  China . . . . . 365

  France . . . . . 473

  Galicia . . . . . 448

  Italy . . . . . 371

  Japan . . . . . 365

  Russia . . . . . 437

  United States . . . . . 371

Petroleum; Mexican . . . . . 130

— in Mexico; imports of American . . . . . 1088

— output of crude . . . . . 1088

— mixtures; directions for testing, Order in Council, 7.5.07 . . . . . 774

— motor launches; Thames Conservancy bye-laws for . . . . . 1152

— naphtha; physical properties of . . . . . 267

— naphthenes in . . . . . 316

— nature of the hydrocarbons in . . . . . 303

— New York Produce Exchange rules for crude . . . . . 744

— nitrogen content of . . . . . 299

— in North Borneo; storage regulations . . . . . 1040

— in Norway; regulations as to . . . . . 1041

— odour of crude . . . . . 257

— in Ohio; production of crude, 1889-1918 . . . . . 1073

— of the Ohio-Indiana field; chemical composition of . . . . . 318

— oils; light, for domestic use . . . . . *br.* 8123

— olefine hydrocarbons in . . . . . 314

— optical activity of . . . . . 298

— — of, as bearing on origin . . . . . 360

— properties of . . . . . *br.* 4581, 6349, 6354, 6362, 6365, 6367-6369, 6371-6373, 6375-6381, 6383, 6388, 6389, 6393, 6394, 6397, 6400, 6401

— Ordinance of Gibraltar . . . . . 1029

— of Labuan . . . . . 1037

— of Malta . . . . . 1038

— of Mauritius . . . . . 1038

— of Montserrat . . . . . 1038

— of Nigeria, Southern . . . . . 1040

— of St. Christopher and Nevis . . . . . 1043

— of St. Lucia . . . . . 1044

— of St. Vincent . . . . . 1044

— of Seychelles . . . . . 1044

— of Sierra Leone . . . . . 1045

— of Straits Settlements . . . . . 1045

— of Trinidad and Tobago . . . . . 1049

— from organic matter; stages in the formation of organic origin from marine organisms . . . . . 353

— — from terrestrial vegetation . . . . . 351

— origin of . . . . . *br.* 195, 228, 233, 234, 242, 248, 505, 557, 581, 655, 695, 696, 799, 975, 999, 1070, 1132, 1145, 1146, 1216, 1306, 1323, 1407, 1455, 1458, 1490-1493, 1495-1497, 1553, 1591, 1653, 1662, 2064, 2069, 2072, 2074, 2075, 2076, 2081, 2082, 2084-2087, 2092, 2192, 2270, 2361, 2383, 2590, 2625, 2834, 2893, 3188, 3331, 3375, 3377, 3401, 3413, 3418, 3472, 3538, 3561, 3592, 3592, 3625, 3630, 3716, 3717, 3763, 3774, 3892, 3910, 3911, 3921, 3924, 3962, 4016, 4104, 4362, 4378, 4380-4382, 4401, 4426, 4601, 5051, 5035, 5039, 5173, 5218, 5226, 5357, 5368, 5476, 5477, 5547, 5549, 5550, 5553, 5557, 5641, 5706, 5707, 5709, 5712, 5713, 5718, 5744, 5872, 5922, 6034, 6063, 6074, 6151, 6152, 6235, 6236, 6293, 6295, 6298, 6329, 6330, 6350, 6493, 6600, 6628, 6785, 6786, 6962, 7104, 7160, 7250, 7313, 7324, 7325, 7359, 7511, 7527, 7601, 7629, 7857, 7977, 7981, 7985, 8011, 8122, 8127, 8362, 8366, 8588, 8591, 8614, 8677, 8705, 8708

— oxygen compounds of . . . . . 347

— paraffins from Pennsylvania . . . . . 311-313

— percentage composition of . . . . . 299

— in Peru; production of . . . . . 1090

— physical properties of . . . . . 257

— — of, from the Apscheron district . . . . . 287, 288

— — of commercial product from . . . . . 267

Petroleum; physiological properties of . . . . . *br.* 420, 1449, 2134, 2238, 2392, 2576, 2758, 2799, 2956, 2987, 4210, 4633, 6170, 6374, 7085, 8261

— in Portugal; regulations as to . . . . . 1042

— preparation of aromatic hydrocarbons from . . . . . 537

— price of, at the wells in the U.S. . . . . 1070

— producing companies in Mexico . . . . . 132-135

— production of . . . . . *br.*

  — of crude, in the Baku field . . . . . 1079

  — calorific value of petroleum and (Russia), classification . . . . . 274

  — methods, A. Beeby Thompson . . . . . 475

  — in Pennsylvania and New York; crude . . . . . 1071

  — in Rumania, 1900, 1908, 1909, 1910 . . . . . 27

  — in the U.S.; early . . . . . 90

  — and value of crude in Canada . . . . . 1092

  — of the world, 1916, 1917, 1918 . . . . . 1096-1098

— products; alkali test for Russian . . . . . 870

  — American, yields and properties . . . . . 541

  — at Baku; yield of . . . . . 556

  — bromine test of . . . . . 868

  — Canadian . . . . . 555

  — classification of Russian . . . . . 556

  — decolorising, by fuller's earth . . . . . 526

  — detection and estimation of rosin oil in . . . . . 876

  — of sulphur in . . . . . 872

  — Eastern U.S. . . . . 546

  — from Alsace oil . . . . . 571

  — exports of, from U.S. . . . . 1069

  — percentage yield of, Eastern U.S. . . . . 546

  — soluble in, or miscible with, water . . . . . 885

  — specifications for . . . . . *br.* 7261

  — uses of . . . . . 883

  — variations of specific gravity of, with temperature . . . . . 273

  — properties of . . . . . *br.* 314, 1191, 2057, 3726, 5364, 5821, 5854, 6803, 7597, 7693

— pumping, through pipe-lines . . . . . 665

— purification, of, by agitation and by compressed air . . . . . 522

  — of, by chemical treatment . . . . . 521

— radio-activity of . . . . . *br.* 6210

— raising the flash-point of . . . . . *br.* 4328

— reagents, action of various, on . . . . . 340

— refineries in the U.S. . . . . 547-554

— refining . . . . . *br.* 468, 616, 1069, 1075, 1103, 1292, 1331, 1332, 1340, 1441, 1600, 1738, 1808, 1870, 2187, 2623, 3053, 3977, 4032, 4706, 4829, 5485, 5630, 5823, 5880, 6520, 6386, 6390, 6819, 6896, 7022, 7366, 8531, 8598, 8800

— — in Austria-Hungary . . . . . 569

— — in Canada . . . . . 554

— — early history . . . . . 476

— — in France . . . . . 576

— — at Lima . . . . . 551

— — in Rumania . . . . . 569

— — in Russia . . . . . 556

— — in Spain . . . . . 577

— — in U.S. . . . . 538

  — utilisation of waste acid and alkali from . . . . . 523

  — refractive index of . . . . . 296

  — regulations in China . . . . . 1017

  — of Denmark . . . . . 1017

— removal of sulphur from Canadian . . . . . 555

— residuum, *see under* Residuum . . . . . 743

— results of continuous distillation of Russian crude . . . . . 493, 494

— in Rumania; production of crude, 1890-1919 . . . . . 1084

  — storage, etc., of . . . . . 1042

— in various Rumanian oil-fields; output of crude . . . . . 1084-1086

— in Russia; production of crude . . . . . 1079

  — regulations as to storage, etc., and mining of . . . . . 1042

— from Russia; specific gravity and flashing-point of crude . . . . . 263

— separation of water from . . . . . *br.* 857

— solid hydrocarbons of . . . . . 326

— solidification of . . . . . 885

  — solidified . . . . . *br.* 174, 1780, 3756, 3795, 6680, 8125

— solubility of iodine and sulphur in . . . . . *br.* 4178

— of water in . . . . . *br.* 2857

— in Spain; regulations as to manufacture and storage of . . . . . 1045

— specific gravities of crude, from America . . . . . 259-262

	PAGE		PAGE
Petroleum; specific gravity of crude, from		2347, 2349, 2394, 2571, 2627, 2663, 2704,	
Bustenari	258	2796, 2818, 2922, 2954, 2974, 3068, 3196,	
— and flashing-point of, from various sources	261	3227, 3270, 3384, 3398, 3407, 3408, 3420,	
— spirit : American	541	3429, 3459, 3482, 3548, 3572, 3592, 3607,	
— analysis of	<i>br.</i> 428, 429, 1513	3775, 3868, 4000, 4022, 4060, 4061, 4083,	
— chemical treatment of	524	4101, 4116, 4204, 4205, 4209, 4230, 4234,	
— constituents of	<i>br.</i> 319-321	4276, 4317, 4478, 4542, 4552, 4692, 4704,	
— detection of sulphur compounds in	872	4722, 4749, 4920, 5013, 5123, 5126, 5128,	
— evaporation of, by a current of air	912, 913	5205, 5206, 5209-5212, 5235, 5256, 5328,	
— explosions of mixtures of, with air	706	5500, 5623, 5661, 5711, 5714, 5717, 5760,	
— fractionation of	751-754	5829, 5831, 5832, 5900, 5964, 5976, 5982-5984,	
— from heavy oil; making	582	6029, 6031, 6109, 6223, 6254, 6342,	
— lamps for burning	909	6357, 6359-6361, 6364, 6411, 6441, 6451,	
— proportion of, in various crude oils	284-286	6454, 6458, 6467, 6490-6492, 6526, 6574,	
— testing	741, 751	6575, 6578, 6640, 6641, 6660, 6733, 6821,	
— turpentine substitutes for	886	7272, 7357, 7444, 7445, 7458, 7473, 7477,	
( <i>See also Benzine.</i> )		7510, 7595, 7598, 7599, 7688, 7696, 7708,	
— spontaneous ignition of	<i>br.</i> 1139, 6258, 8608	7789, 7978, 7982, 8173, 8175, 8248, 8249,	
— stability of compounds	<i>br.</i> 8199	8251, 8254, 8369, 8370, 8439, 8440, 8441,	
— storage of, in Canada	673	8507, 8600, 8616, 8624, 8625, 8628, 8631,	
— of crude, in the U.S.	666	8720, 8738, 8752, 8753, 8783, 8803	
— and distribution of refined, in England	675	Petroliferous regions and seismic zones	<i>br.</i> 7594
— of, in Russia	714	Petrovsk	<i>br.</i> 1093
— sulphur content of	300	Petrozocene	<i>br.</i> 7859
— sulphuric acid treatment of Russian	519	Pharmacy; petroleum products in	883
— from Sumatra and Cebu; products from crude	291	Phenol in petroleum	322
sunning and reducing	547	Philadelphia pipe-line	659
supply; duration of the	172, 942	— storage and testing regulations in	1058
— Swedish laws as to storage, etc., of	1046	Phillip, A., and L. J. Steele; inflammable gas or	
— in Switzerland; regulations as to	1047	vapour detector	813
— synthesis of	<i>br.</i> 3979, 4639, 6350, 6760, 6770	Philippine Islands; distribution of petroleum in	215
— synthetic acids from	324	— import duties on petroleum products	1146
— systematic working of	<i>br.</i> 3447, 4003, 5748	— petroleum in the	72
— tank barges; Thames Conservancy specification for	1005	— industry of the	<i>br.</i> 6530
— temperature of ignition of	709	— specific gravity and flashing-point of crude petroleum from	266
— testing	<i>br.</i> 9, 11, 98, 354, 408, 574, 575, 576, 633, 640, 641, 941, 1000, 1193, 2055, 2093, 2094, 2125, 2518, 2996, 3023, 3079, 3283, 3326, 3342, 3485, 3727, 3732, 3908, 3914, 3934, 3936, 3976, 3993, 4056, 4059, 4063, 4067, 4068, 4077, 4086, 4111, 4282, 5243, 5353, 6462, 6683, 6788, 6891, 6892, 6964, 7162, 7163, 7165-7170, 7172, 7173, 7196, 7197, 7243, 7600, 7785, 7891, 7924, 7937, 8108, 8268, 8597, 8757	Phillips, F. C.; natural gas; analyses of	343-346
— Abel's investigation of	767	— petroleum, origin of	358
— apparatus; regulations under the Act of 1879	985	Phillips's fluidimeter	819
— crude	741, 744	Phillips well, U.S.A.	89
— from Texas; chemical nature of	319	Phlog-claio-mètre	802
— Thames Conservancy byelaws as to	1002	Phosphorus in petroleum	303
— transport of, early methods	655	Photogen	<i>br.</i> 884, 1083, 3574, 3701, 4218, 4912, 6703-6705, 7884, 8053, 8055, 8056, 8101-8103
— of, in Mexico	673	— industry	<i>br.</i> 2944, 2948, 6868, 6935
— by rail	668	Photometric lamps	<i>br.</i> 2002
— in Russia	674	— tests of kerosenes	760
— storage, and distribution of, in the U.K.	715	Phyosterin; separating, from mineral oils	<i>br.</i> 5029, 5030
— in the U.S.	655	Piauxite	<i>br.</i> 3035
— by water	679	Pichu-calco	<i>br.</i> 124
— in Turkey; regulations as to	1050	a-Picoline in brown-coal tar	<i>br.</i> 2429
— in turpentine; estimation of	<i>br.</i> 1126, 1498, 1499, 1966	Pin-socket	382
— in the U.K.; production of crude	1094	Pintsch's oil-gas plant	922
— in the U.S.; production of crude, from 1859-1918	1066, 1067, 1068, 1069	Pipe-line runs in the Appalachian oil-field	1072
— in the U.S.; regulations as to storage and testing of	1050	— system in California	660
— use of, as detergent	886	Pipe-lines; Mexican	673
— uses of	883	— pumping oil through	665
— vapour and air; formation of explosive mixtures of	702	— rifled	660
— inflammability of mixtures of	920	— Russian	676
— experiments with	<i>br.</i> 3208	— in the U.S.	656
— testing for	<i>br.</i> 3209	(general)	<i>br.</i> 4696, 4699, 4700, 5624, 6183, 8068, 8767
— viscosity of	295	Pipe, riveted	419
— wells of Japan; method and cost of digging	365	Pipette viscometers	821
— in West Virginia, production of crude from 1889-1910	1074	Pitch; distinguishing coal-tar, from natural asphalt.	880
— (general)	1061	— lake of Trinidad	141
<i>br.</i> 140, 189, 243, 251, 267, 287, 324, 386, 388, 417, 439, 459, 499, 645, 768, 854, 872, 941, 974, 997, 1065, 1076, 1083, 1084, 1092, 1108, 1159, 1266, 1336, 1436, 1479, 1549, 1696, 1751, 1856, 1840, 1895, 1916, 1934-1936, 1945, 1946, 1954, 2050, 2051, 2062, 2079, 2095, 2096, 2126, 2155, 2163, 2165, 2202, 2234, 2235, 2296, 2298,		— in petroleum; estimation of	<i>br.</i> 2078, 3981
		— production of mineral, in Russia	1124
		— testing	<i>br.</i> 601, 2488
		— Trinidad	<i>br.</i> 1556, 5017, 5484, 5698, 5988, 6001, 7280, 7773, 7807
		Pitch-coal	643
		Pitches from bitumen and fats	<i>br.</i> 3478
		Pitchford, Shropshire; bitumen at	39
		Pithole; history of	<i>br.</i> 1551
		— petroleum discoveries at	89
		Pittsburgh gas-fields	96
		Pochon; Pechelbronn crude oil, refining	571
		Pockets; oil in	167
		Poisoning by petroleum	<i>br.</i> 4633
		Poland; petroleum in	<i>br.</i> 6906, 7550, 8671
		Polymethylenes	307
		Port-aux-Poules, Algeria; petroleum at	49
		Port Huron oil-field	<i>br.</i> 2712

	PAGE		PAGE
Portland (Maine); storage regulations	1053	Rangoon; refining treatment at	505
— (Oregon); storage regulations	1057	“Rangoon tar”	67
Porto Rico; occurrences of petroleum in	247	“Rapid” system of drilling	458
Portugal and Colonies; import duties on petroleum		Raton, New Mexico	<i>br.</i> 4368
— products	1146	Reagent, Etard's	341
— distribution of petroleum in	177	Readers	377, 385
— petroleum in	<i>br.</i> 51	Redistillation of heavy oil and paraffin	505
— decrees	1042	Red Sea crude petroleum; specific gravity and	
Portuguese East Africa; occurrence of petroliferous		flashing-point of	265
deposits in	252	— oil deposits	49
Postlethwaite's extinguisher	902, 903	— petroleum	<i>br.</i> 283, 466, 467, 7399, 7816
Potok oil-field, Galicia; historical account	21	“Reduced bits	476
Poughkeepsie, N. Y.; storage regulations in	1056	Reducing process	547
Poverty Bay, N. Z.; geology of	<i>br.</i> 63, 103, 3360	Redwood, B.; burning quality of oils; test for	759
— petroleum deposits of	154	— explosive mixtures of petroleum vapour and air	702, 703
Power production; uses of petroleum products for	883, 965	— future supply of petroleum	942
— relative costs of different forms of, in Baku	445	— kerosene; fractions of American and Russian	758
Prahova field; output of petroleum from	1085	— photometric tests of American and Russian	760
Presses for testing paraffin	863, 864	— lamps; consumption of oil by	897
Pressure; correction of flash-point for atmospheric,		— paraffin-testing process	863
779, 780, 784, 788, 789, 791		— vapour-testing apparatus	809-813
— effect of barometric, on the flashing-point	776	— viscometer	823-825
— of gas in wells	428	— and friction-testing machine; comparative	
— in Russian wells	443	value of tests with	842
— in wells and its cause	170	— viscosity of American and Russian mineral oils	
Price of crude oil in various U.S. fields	1069-1071	compared with water and other oils	293
Priestman spray-maker and vaporiser	967-968	— and E. R. Blundstone; petroleum and distil-	
— oil-engine	967-968	lates; evaporation of, by dry-air current	912, 913
Princeton oil-field, Indiana	<i>br.</i> 805	— see Abel	904
Producer gas; plant for making enriched	928, 929	— see Dewar	579
Propane	311	— see Thomson	753, 773
Provincial Natural Gas and Fuel Co. of Ontario	83	Redwood-Barringer registering water-finder	720
Prussia; petroleum in, historical	37	Refineries (general)	<i>br.</i> 3040, 5023
Prussian railways; lubricating oil specifications	857	— in Baku district	557
— testing of lubricants for	<i>br.</i> 119	— in Rumania	30
Pseudocumene in petroleum	<i>br.</i> 2058	Refinery improvements	<i>br.</i> 1095
Pumpherton shales	<i>br.</i> 1178	— in the U.S.; description of a	544
Pumping engines in Galicia	468	— waste; utilisation of	<i>br.</i> 3919, 6507
— for gas-wells	431	Refining crude shale-oil	625
— natural gas	<i>br.</i> 4890, 6443, 8237	— petroleum in Canada	554
— by oil-engines	<i>br.</i> 1320, 3167, 4525	— in France	576
— oil through pipe-lines	665	— in Germany	571
— petroleum	<i>br.</i> 959, 3612, 3657, 3681	(See also Alsace.)	
— wells	420	— and ozokerite in Austria-Hungary	559
Pumps for forcing oil through pipe-lines	665	— in Rumania	569
— used in Galicia	468	— in Russia	556
Punjab; geology of	<i>br.</i> 2327, 2328, 8528, 8530	— in Spain	577
— oil springs in the	58	Refractive index	296, 297
— petroleum in	<i>br.</i> 2251, 4816, 4817, 4935, 6455, 8527	— indices of various petroleum distillates	297
— production and value of crude oil in	1087	Refrigerators for producing paraffin	632-637
Purification processes	512	Regnault's distilling apparatus	750
Puy-de-Dôme gas and bitumen	<i>br.</i> 4521	Reichelheim and Machlet gas-process	<i>br.</i> 8781
Puy de la Poix; bitumen from	47, 179	Relation of production and consumption	94
Pyrene	<i>br.</i> 4472	Remarks on petroleum and natural-gas production	162
Pyrenees	<i>br.</i> 1233, 7716	Reservoir-rocks; characters of	161, 162
Pyridine in shale naphtha	<i>br.</i> 8381	— oil and gas	
Pyrymont bitumen mines	<i>br.</i> 6306, 6727	Reservoirs; apparatus for examining	<i>br.</i> 2873-2875
Pyrogenic compounds	<i>br.</i> 653, 665, 669	— asphalt lining of	<i>br.</i> 7019
Pyronaphtha; fractions of Russian	757	— measuring oil in	<i>br.</i> 8350
QUARTZ crystals; petroleum inclusions in,	<i>br.</i> 6472	— oil	<i>br.</i> 2884, 3704, 4977, 5779, 7834, 8457
Quayle, see Mabery, C. F.	301	— use in Russia	677
Quebec; distribution of petroleum and gas in	220	Residual from American petroleum	541, 546
— natural gas in	<i>br.</i> 4349	— definition of	867
Queensland; petroliferous deposits in	<i>br.</i> 424	— determination of the calorific value of	750
RADIO-ACTIVITY of mineral oils	<i>br.</i> 3365, 3617-3620	— exports from the U.S.	1069
— of Rumanian oils	299	— of, from the U.S., 1903-1918	1075-1078
Raeburn shale	609	— flash-point of	<i>br.</i> 8786
Ragozine; petroleum from the Apscheron district,		— products from German	571-576
physical properties of	286, 287	(See Alsace.)	
Ragozine's distilling and fractionating process	<i>br.</i> 72, 7453, 8442, 8607	— from Russian crude oil	556-559
Railway carriage lighting; oil-gas for	924	— standard for	<i>br.</i> 1595
— oil-fuel on a State	<i>br.</i> 8455	— testing	743, 868
Railways; lubricating oil specifications of German	857-859	— utilisation of	<i>br.</i> 43, 1900, 2865, 3927, 5630, 5844, 7095, 7894, 7912-7915, 7983, 7984, 8446, 8450, 8603
— in the U.S.; consumption of fuel-oil by	1079	— (general)	<i>br.</i> 278, 519, 1838, 3486, 3487, 3496, 3829, 3927, 4867, 4868
— use of oil-fuel on	945-949	Resin from naphtha and bitumens; obtaining	<i>br.</i> 71
Raising oil by means of compressed air	446	— solid	<i>br.</i> 1875,
Raky drilling rig	461-463	Resinous products in mineral oils	3488, 3495
Ramdohr paraffin mixer	543, 544	Resins; mineral	<i>br.</i> 3771, 3773, 3792, 4093, 6037, 6985, 6986
Rangoon petroleum; Burma	<i>br.</i> 1341, 2819, 4462, 8196	Retene	<i>br.</i> 5998, 6916
		Retinasphaltum	<i>br.</i> 2287, 3773, 5292
		Retinite	<i>br.</i> 8664

	PAGE		PAGE
Retort; Oakbank .....	622	Rumania; distribution of petroleum in .....	189, 265
Retorts for shale distillation; Bryson and others ..	618, 619	— geology of .... <i>br.</i> 1837, 5431-5434, 5437-5440,	
— — — Continuous .....	611, 612	5442-5446, 6933	
— — — Henderson's .....	613-617, 621, 624, 625, 626	— import duties on petroleum products .....	1147
— — — Pentland's .....	615, 616	— oil-fields of .... <i>br.</i> 109, 144, 150, 151, 240, 266,	
— — — Young and Brash .....	614	269, 270, 606, 981, 1716, 2274, 2380, 2531,	
— — — and Beilby .....	617	5220-5328, 5439-5440, 5558, 5715, 6842,	
— — — and Fyfe .....	618	7401, 7502, 7562, 7565, 7587, 7605, 7781,	
Rettich; Mitrailleuse burner .....	893, 894	7791	30
Reunion Is.; import duties on petroleum products	1146	— petroleum analysis .....	321
Rhenish Bavaria and Rhenish Prussia; petroli-		— — deposits of, historical .....	25
ferous deposits in .....	196	— — industry of .... <i>br.</i> 152, 156, 311, 313, 530-	
— American .....	541	532, 612, 815, 1199, 1561, 1761, 1762,	
— as anesthetic .....	883	1890, 1909, 2206, 2621, 2723, 3042, 3450,	
Rhine Valley .....	<i>br.</i> 2080	3494, 3831-3833, 4400, 5215, 5441, 5511,	
Rhode Island; storage and testing regulations ..	1059	5570, 5572, 5766, 6536-6538, 7344, 7515,	
Rhodesia; occurrence of petroleum in .....	252	7596, 7767, 7792, 7861, 8340	
Richardson, C.; petroleum, constituents of .....	316	— — refining in .....	569
Riche, A., and G. Halphen; petroleum distillates,		— — regulations in .....	1042
testing of .....	868	— production in, in 1900, 1908, 1909, 1910 .....	27
Richmond, Va.; storage and testing regulations in	1060	— pipe-lines .....	28, 29, 679
Richter; Benzoline vapour, explosion of .....	711	Rumanian crude petroleum; specific gravities of ..	258, 265
Rico di PernoVA; petroleum deposits of .....	42	— petroleum .... <i>br.</i> 104, 943, 1933, 1938, 1940,	
Riddings Colliery, Alfreton; petroleum deposit at,	81	1944, 1949, 2508, 2837, 6186, 6188, 6191,	
Riebeck's oil and paraffin works .....	<i>br.</i> 8772	6356, 6391, 6679, 6814, 7003, 7586, 8451,	
Riga .....	200	8707	
Riley, J.; furnaces; oil-firing of .....	944	— — industry; statistics of the .....	1084, 1085, 1086
Rivanazzano; oil-wells at .....	34	Rumanite .....	<i>br.</i> 3671, 3673
River pollution with petroleum products. <i>br.</i> 4118,		Rusden-Eeles burner .....	951, 953
4873, 5622		Russia, Apscheron district; physical properties of	
Rivet-catcher .....	421, 424	— asphalt and mineral pitch production in .....	1124
Riveted pipe .....	419	— composition of natural gas from .....	345
Road sprinkling .....	886	— distribution of petroleum in .....	200
— treatment .. <i>br.</i> 6, 491, 1150, 1505, 2136,		— import duties on petroleum products in .....	1147
2228, 3562-3566, 3568, 3799, 4404, 4759,		— methods of producing petroleum in .....	437, 442
5005, 5006, 5660, 5851, 5852, 6552, 6558		— natural gas in .....	448
— wagons .....	721	— oil reservoirs used in .....	677
Roberts; torpeding wells .....	425	— ozokerite, production of .....	1121
Robinson, W.; oil-engines, classification of .....	966	— paraffin manufacture in .....	<i>br.</i> 4005
"Rochester" lamp .....	894	— petroleum in .... <i>br.</i> 318, 387, 552, 569, 726,	
Rock; asphalt, see <i>under</i> Asphalt.		729, 730, 830, 938, 1290, 1297, 1919, 2121,	
— tar .....	191	2825, 2969, 3149, 3150, 3152, 3155, 3159,	
Rocket oil-engine .....	<i>br.</i> 296	3520, 3684, 3871, 3927, 3928, 3951, 4218,	
Rocks; characteristics of reservoir .....	162	4510, 4690, 4708, 5072, 5120, 5343, 5925,	
— oil and gas reservoir .....	161	6264, 6781, 6805, 7315, 7397, 7628, 7682-	
— petroliferous .....	<i>br.</i> 6758, 7390	7684, 7694, 7759, 7851, 7942, 7952, 8367,	
Rocky Mountains .....	<i>br.</i> 898	8445, 8627	
Rohr, India; petroleum deposits near .....	59	— petroleum decree .....	1042
Roman oil-field .....	5, 6, 9, 206	— — industry in .... <i>br.</i> 4229, 5633, 6385, 6396,	
— — — number and condition of wells in the	1080	6450, 7144, 8762, 8771, 8785	
Rome; petroleum storage regulations in .....	1035	— — mining regulations in .....	1043
— — — province .....	<i>br.</i> 4	— production of crude petroleum in .....	1079
Rope-grab .....	383, 384	— refining petroleum in .....	556
— — — socket .....	377	— specific gravity and flashing-point of crude	
— — — spear .....	383, 384	petroleum from .....	263
— — — worm .....	386	— storage of petroleum in .....	674-678
Rose Hill, Ruabon; petroleum at .....	41	— tests for refined kerosene in .....	556
Rosebladt's flash-point method .....	876	— transport of petroleum in .....	674
Rosin oil; detection of, in mineral oils .....	808	— use of oil as fuel in .....	941
— — — determination of, mineral oils in .... <i>br.</i> 1730,		Russian crude oil; results of continuous distilla-	
2853, 3450, 3451, 4109	876	tion of .....	493, 494
— — — of mineral oils in .... <i>br.</i> 66, 2291, 3481,		— distilling system .....	481
7961		— kerosene; photometric tests of .....	759
— — — from mineral oil; separating .... <i>br.</i> 4917		— — and solar oil; fractions of .....	757
Ross, O. C. D.; petroleum, theory of inorganic		— tests applied to, at Baku .....	756
origin of .....	350	— mineral oils; calorific value and composition	
Rossmässler, F. A.; refining perfumery and mixing		of .....	<i>br.</i> 121, 135
oils .....	531	— petroleum fractions .....	520
Ross-shire; asphaltum in .....	<i>br.</i> 8458	— — — industry; historical account of the .....	3
Rotary system of drilling .....	397, 439	— — — products; alkali test for .....	870
— — — log .....	403	— — — classification of .....	556
Rotterdam; regulations as to storage and convey-		— pipe-lines .....	<i>br.</i> 2378
ance of inflammable liquids .....	1032	— stills .....	481, 482, 483
Rowan, see Mills		Rust prevention .....	<i>br.</i> 4224, 4225, 6857
Rowatt, T.; anaaptic burner .....	892, 893	<i>Ruth</i> ; explosion on the brigantine .....	697
— — — Lorne burner .....	892, 893	SABA; import duties on petroleum products in ..	1147
Royal Dutch Company .....	68	Sabatier and Senderens; hydrocarbons from	
Ruabon; occurrence of petroleum at .....	41	acetylenes, formation of liquid .....	350
Rubber industry; use of petroleum in the .....		Sabuntchi field; number and condition of wells in	
— — — manufacturers in London; licensed, using		the .....	1080
petroleum .....	991	Sacramento; storage and testing regulations .....	1050
— — — mixings .....	<i>br.</i> 2133	— "Sacred fire" .....	213
— — — solutions; use of Abel-test for .....	772, 784	— "Safety-gas" .....	920
Rumania; conditions of wells in, in 1916 .....	1086	Sagara oil-field, Japan .....	75
— — — crude oil production of, 1890-1919 .....	1084	Sailing vessels; list of tank .....	739
— — — in various oil-fields of .....	1085		

	PAGE		PAGE
St. Christopher, St. Croix, St. Eustache, St. Helena, St. Lucia, and St. Martin; import duties on mineral oils	1149	Sedgwick, <i>see</i> Maxim	916
St. Christopher and Nevis; Petroleum and Explosives Ordinance, 1909	1043	Seefeld; asphalt industry of . . . . . <i>br.</i> 2342, 3664	
St. Lucia; Petroleum Ordinances	1044	Selligie; paraffin manufacture, patents on	589, 595
St. Pierre-Miquelon, St. Thomas, and St. Vincent; import duties on mineral oils	1149, 1150	Senderens, <i>see</i> Sabatier	350
St. Vincent; Explosives and Petroleum Ordinances, Sainte-Claire-Deville; table of composition and properties of various oils	1044	Seneca Oil Company	88
Sakhalin asphalt deposits	286	Separating gas and oil from wells	425
— crude petroleum; specific gravity and flashing-point of	353	— oil and water	<i>br.</i> 7768
— petroleum deposits in	263	Separators	481, 483
(general) . . . . . <i>br.</i> 83, 517, 870, 1049, 1593, 2737, 3156, 3394, 5131, 5179, 6179, 6378, 7757, 7846	19	Sepulchre's "Deffries" lamp	892, 893
Salining process	518	Serbia; distribution of petroleum in	189
Salleron-Urban flash-point tester	807	— import duties on petroleum products in	1147
"Saloon oil"	560	— paraffin shale in	<i>br.</i> 2855
Salsomaggiore; natural gas at	55	— shale deposits of	607
— petroleum	31	Setting-point of mineral oil; determination of	<i>br.</i> 6994-6996
— production and refining at	34	Seychelles; Dangerous Goods Ordinance	1044
(general) . . . . . <i>br.</i> 7989, 7990		— import duties on mineral oils and wax	1148
Salsomnoro; natural gas at	35	Seyssel asphalt-rock; composition of	334
Salt with petroleum; the association of	168	Seyssel-Gyrmont bitumen . . . . . <i>br.</i> 5136, 7142, 7906	180
Salt Lake Basin, Utah	<i>br.</i> 951	Shale deposits in New Brunswick	606
Salt Province bitumen	<i>br.</i> 276	— in Nova Scotia	606
Salvador; import duties on petroleum products	1147	— in Serbia and Spain	607
Samaauw; occurrence of petroleum in	216	— distillation of . . . . . <i>br.</i> 4353, 6599, 6719, 8047, 8048, 8380, 8381	
Samara	<i>br.</i> 2120, 2131, 8124	— distillation; treatment of ammoniacal liquor	
Sampling oil and natural gas	1026	— from	623
— petroleum by the Bremen Exchange	1026	— distillation in Scotland	611
San Domingo; petroleum in	<i>br.</i> 2496, 8731, 8747	— in France; production of bituminous	1130
Sand-pumps; American	377, 381, 382, 385, 389	— geological formation of Scottish	609
Sandstones as oil and gas reservoir-rocks	162	— in Great Britain	1128, 1129
San Francisco; storage and testing regulations	1050	— output of oil	600 <i>et seq.</i>
San Giovanni di Incarico; oil-wells at	35	— kerosene, of New South Wales	604, 605
San Juan oil-field, Utah	<i>br.</i> 2816, 3718, 4383	— Kimmeridge	600
San Luis District, Colorado	<i>br.</i> 2045, 4385	— manufacture of oil from, in the U.S.	87
San Luis Obispo and San Mateo counties, California, oil-fields in	124	— mining and winning, in Scotland	610
Sanok-Chyrow oil-field, Galicia; historical account	21	— naphtha	632
S. Sabbia; petroleum harbour regulations	1012	— in New South Wales; production of kerosene	1130
Santa Barbara and Santa Clara counties, California, oil-wells in	124	— New Zealand bituminous	604
Sarawak; import duty on kerosene in	1147	— in New Zealand; output and value of oil	1131
— petroleum in	71	Ohio	107
— production, 1911-1917	71	Shale-oil; composition of . . . . . <i>br.</i> 2033, 2425, 3332, 3382, 6726, 6796	
(general) . . . . . <i>br.</i> 2148		— gas	<i>br.</i> 6503, 7055, 7057
Sardinia; petroleum-like substance in	184	— industry, the . . . . . <i>br.</i> 573, 1329, 2768, 3063, 3237, 3261, 6467	589
Sargent oil-field, California	<i>br.</i> 3789	— of France	595-600
Saros; geology of	<i>br.</i> 70	— phenols	<i>br.</i> 2808
Saskatchewan; natural gas in	218	— products; French	598
Savannah; storage regulations	1051	— properties and refining of crude	625
Saxony; lignite distillation in	603	— refining	<i>br.</i> 7384
— petroliferous deposits in	198	— residues	<i>br.</i> 897
— State Railways; lubricating oil specifications	859	— still, intermittent	628
(general) . . . . . <i>br.</i> 885, 2863, 3705, 5456, 8676		— stills	611 <i>et seq.</i>
Saybolt's electric flash-point tester	765	— Henderson's	623-632
— testing lamp	759	— testing crude	743, 877
— viscometer	828, 829	— yield of products from crude Scottish	641
Scale analysis; Scottish methods of	865	Shale; oilines in	<i>br.</i> 161
<i>See also under</i> Paraffin.		— products; bromine test of	868
Scheererite . . . . . <i>br.</i> 4253, 5638, 7482		— properties of oil	590
Schemakha; earthquakes at	<i>br.</i> 23	— retorts at Broxburn	<i>br.</i> 3257
Schleswig-Holstein; petroliferous deposits in	198	— Bryson and others	618, 619
Schmidt; natural gas from Russia; composition of, Schukhoff, Intehik, and Bary's continuous distilling apparatus	315	— Continentous	611-612
Schultze; lubricating oils, cold test apparatus for, Schwaeweller oil-field; the	493	— Henderson	613, 615, 622
Scotland; bitumen deposits in . . . . . <i>br.</i> 193, 194, 1527	855	— Pentland	615, 616
— distribution of petroleum in	175	— Young and Belby	617, 617
— mining of winning shale in	610	— and Brash	613, 614
— shale-oil industry of . . . . . <i>br.</i> 1329, 2768, 3063, 3237, 3262, 5174, 5382, 6467, 7386, 7610	589	— and Fyfe	618-621
Scottish methods of testing paraffin scale and heavy mineral oils	865	— seams; principal Scottish	609
— oil companies, the	590	— spirit; testing	741, 751
— oil-shales . . . . . <i>br.</i> 1158, 1160-1162, 1178, 1527, 2021, 2022, 8103-8246		— in the U.K.; output and value of oil	1127
— physical characters	591	— vapours; treatment of, compression	623
— oil works; products of the	589 <i>et seq.</i>	— condensation	622
— shale; geological formation	591	— scrubbing	623
Scrubbing gases from shale distillation	623	Shales; analysis of oil . . . . . <i>br.</i> 4611	
		— bituminous . . . . . <i>br.</i> 312, 942, 1271, 1339, 1697-1699, 1739, 2613, 4957, 5140, 5949, 5950, 7147, 8030, 8425	
		— oil . . . . . <i>br.</i> 306, 352, 425, 506-508, 691, 776, 993, 1054, 1158, 1160-1162, 1178, 1217, 1247-1250, 1527, 1641, 1861, 1893, 2021, 2027, 2262, 2697, 2770, 2835, 2919, 3604, 4469, 4470, 6529, 7379, 7609, 7611, 8246	
		— slatey, as reservoir-rocks	162
		Sherring's Victoria lamp	902
		Ships; Thames Conservancy rules as to petroleum	1002
		— use of oil-fuel on	948, 951, 959, 975
		Ships' lights	907

	PAGE		PAGE
Shropshire; bitumen in .....	br. 6585	Specific gravity of crude petroleum from various sources .....	258-267
— coal-field .....	br. 85	— — petroleum .....	745
— petroleum in .....	br. 6419	— — determination of .....	br. 1058, 3777, 5342, 5979, 6111, 6833, 6878, 7260, 7300, 7353, 7456, 7577
Siam; distribution of petroleum in .....	214	— heat of mineral oils .....	br. 2753
— import duties in mineral oils in .....	1148	— — of motor spirits, kerosenes, and fuel-oils .....	279
Siberia; petroleum deposits in Western and Eastern .....	207	— — of petroleum hydrocarbons .....	277
— (general) .....	br. 259, 866, 6523	Specular coal .....	643
Sicily; distribution of petroleum in .....	184	Spencer, A.; Report to London County Council on petroleum licenses .....	991
— petroleum industry in .....	31	Spermaeeti oil mixed with mineral oil; analysis of .....	br. 4731
— (general) .....	br. 431, 2259-2261, 2867, 3745, 4773	Spiegeleisen; formation of petroleum-like hydrocarbons from .....	349
Siemens Bros.; oil springs and refinery .....	br. 4718	Spitzbergen; distribution of petroleum in .....	200
Sierra Leone; import duties on mineral oils .....	1148	Spray lamps .....	907
— Petroleum Ordinance .....	1045	— maker; Priestman .....	968
Silesia; petroliferous deposits in .....	194	Springer carburetted water-gas process .....	927
Silliman, B.; investigations of American petroleum, — "Seneca oil" spring .....	256	"Spring pole" for boring .....	88
— "Seneca oil" spring .....	85	Spud .....	383, 384
Silver in the ash of petroleum .....	303	"Spudding" .....	387
Sivertip; explosion on the tank steamer .....	701	Squire; alcohol, purification of, by hydrocarbons, — open-test apparatus .....	886
Sobiborsk .....	br. 2120, 2130, 2582, 4666, 8124	Stacks with fuel-oil; size of .....	br. 1894
Simplex carburettor .....	919	Staffordshire; mineral oils in .....	br. 5967, 8137
Singu oil-fields, Burma .....	61	Stammer chromometer .....	761
Sinker bar .....	377	Standard Oil Co. .....	br. 279, 5374, 5571, 7154
Sisterville oil-field, U.S.A. .....	101	Stapfer, see Ingram .....	851
"Skunk" .....	515	Steam distillation .....	477
Slate-coal .....	643	— generation by oil-fuel .....	941, 945, 947
Slavonia; oily marls in .....	191	Steamers for carrying oil .....	br. 1935, 6589, 6911, 7659, 7992, 8135
Slime pits .....	187	— cleaning bulk-oil, for receiving grain, etc. ....	694
Slip-socket .....	382	— liquid-fuel firing for .....	br. 1246, 1853, 2324, 3590, 3634, 3829, 4123, 5402, 5783, 7063, 7068, 7398, 8793
Sloboda-Rungurska district, Galicia; specific gravity of crude petroleum from .....	263	— list of tank .....	725-738
— field, Galicia; the .....	20	— Russian tank .....	674
Sludge from acid treatment .....	546	— tank .....	679, 682, 725
"Slush oil" .....	99	Stearic acid in petroleum; detection of .....	br. 8117
Smelting; use of oil in .....	br. 519, 3059, 3706, 7936, 8280	Stearin pitch .....	br. 1812
Smith, G. O.; petroleum resources of California .....	116	Stearna Romana; lubricating oils from the Bucharest refinery of the .....	294
Smith's Ferry oil-field, U.S.A. .....	101	Steel barrels .....	723
Soap in mineral oil; detection of .....	br. 4301	Steele, L. J., see Phillip, A. ....	813
Soaps; mineral oil .....	br. 1742, 3806, 4302, 4655, 4953, 5130, 8577	Stepanoff, A., see Lisenko, K. ....	870
— petroleum in .....	886	Stewart shale .....	609
Sockets; horn-, slip-, pin-, and mandrel .....	382, 384, 385	Still gauge; Heckmann's .....	503
Sokoloff; petroleum, theory of inorganic origin of .....	350	Stills; American horizontal cylindrical .....	479, 480
Solar-oil .....	br. 1083, 2125, 3574, 3992, 4703, 4705, 7114, 8041	— Benton's .....	579, 580
— burner .....	br. 7109	— Canadian .....	554
— fractions of Russian .....	757	— Cheese-box .....	480, 481
— Russian .....	520, 557	— Continuous .....	488, 490, 511
Somalland; import duties on petroleum products, — oil .....	1148	— Hill and Thurm .....	489, 490
Sone, L. V.; vessels for transporting liquid oil .....	158	— Stombs and Brace .....	486
Sounding apparatus for storage tanks .....	680	— Tait and Avis .....	487, 488
South African Union (Cape Colony); import duties on mineral oils .....	719	— Dewar-Redwood .....	579, 581
South America; distribution of petroleum in .....	249	— Heckmann's horizontal .....	502, 503
— petroleum and asphalt in .....	br. 2461, 2789	— vertical .....	502, 504
— deposits in .....	144	— for making lubricating oils; Russian .....	505, 506
South Australia; Inflammable Oils Act, 1908, of .....	1011	— Russian .....	482, 483, 484
— occurrence of petroleum in .....	253	— cracking .....	478
— (general) .....	br. 1051, 1052	— for shale-oils; Henderson's .....	623-632
South Carolina; storage regulations .....	1059	— Intermittent .....	628
Southcombe, J. E.; lubrication of engines, deposits from .....	819	— for testing oils .....	br. 3732
South Dakota; storage and testing regulations .....	1059	— Trumble's .....	498, 499
Southern Nigeria .....	br. 5889, 5890, 5892	— used at Baku .....	558
Southern pipe-line (U.S.) .....	658, 659	— vacuum .....	507
Southgate Colliery, Clowne; petroleum at the .....	39	— wagon .....	481
Sözmezö; oil-wells at .....	br. 2989, 8158, 8163, 8166	Stinkstone .....	br. 7204
Spain; distribution of petroleum in .....	177	"Stirring" places .....	365
— import duties on mineral oils in .....	1148	Stoddard's flash-point method .....	805
— petroleum deposits in .....	577	Stombs, D. S., and J. Brace; continuous still and distilling process .....	486
— refining in .....	47	Storage of crude petroleum in the U.S. ....	666
— production of asphalt-rock in .....	1124	— of petroleum; British Acts relative to .....	979
— regulations as to petroleum in .....	1045	— in Canada .....	673
— shale deposits in .....	607	— French decrees as to .....	1019-1023
— specific gravity and flashing-point of crude petroleum from .....	265	— German regulations as to .....	1023-1029
— (general) .....	br. 275, 887, 1179, 2757, 4782, 8408	— London County Council licenses for .....	994-1002
Specific gravity and Baumé equivalents .....	746	— in Russia .....	677
— — and coefficient of expansion, relation between .....	268	— in the U.K. ....	715
— — of crude petroleum and petroleum products, determination of the .....	745	— tank for kerosene; domestic .....	724
		— tanks; sounding apparatus for .....	719
		— specifications for .....	667, 669



	PAGE		PAGE
Storage tanks; water finders for	720	TABASCO, Mexico; oil-wells in	136
— (general)	br. 381, 751, 859, 1263, 1280, 1438, 2166, 4480, 5141, 5463, 6093, 6736, 6910, 7327, 7834	Tagliabue, C. J.; paraffin tester	862
Stoves; oil	br. 441, 4537, 6128, 8673	Tagliabue, G.; closed flash-point tester	797
Straciotta, F., see Bartoli, A.	269	— lubricating oils; cold test, apparatus for	855
Straits Settlements; Petroleum Ordinances	1045	— open test instrument	763
Strata; capacity of various oil and gas	162, 163	Tait, A. H., and J. W. Avis; Continuous still	487, 488
— sometimes confused	205	Taman Peninsula; petroliferous deposits in	
Stratameter; Gothan's	br. 7734	br. 27, 28, 40, 45, 232, 254, 1820, 3243, 4191, 4214, 4408, 5865, 6112, 6664, 8087, 8740	201
Structural conditions affecting accumulation of oil and gas	164	Tampico oil-field	br. 435
Styria; petroliferous sandstone in	191	Tancarville; explosion on s.s.	699
Suberane	br. 5075, 5076	Tangye oil-engine	972
Submarine oil- and gas-wells	206	Tank; United Pipe-Lines specification for a	
Sucker-rod elevator	424	35,000 barrel	667
— spear	384	Tank barges	671
Sudbury district, Ontario	br. 462, 5290	— Thames Conservancy specification for	1005
Suez Canal; petroleum of	br. 177	Tank-cars; loading rack for	668, 671
— regulations for passage of ships laden with petroleum	689	— used in the U.S.	668
Sulphur in asphalt; determination of	br. 3372, 4431	Tank sailing vessels; list of	739
— compounds from Canadian petroleum	301	— steamers	725
— in mineral oils	br. 2073, 3854, 3917, 3922, 3971, 4078, 4756, 4862, 4863, 4867, 4869	— cleaning, to receive grain, etc.	694
— spirit; detection of	872	— explosions on	697-702
— in crude petroleum; percentage of	301	— list of	725
— in oils; determination of	br. 163, 366, 2285, 2442, 2443, 2524, 2665, 2741, 3315, 3330, 3425, 3999, 4182, 4651, 4834, 4962, 5148, 6011, 6789	— precautions in managing	712
— in petroleum products; detection and estimation of	872	— Russian	674
— removal of, from Canadian oils	555	— in the Suez Canal; regulations for	689
Sulphuretted hydrogen in petroleum	302	— ventilation of	695, 704, 713
Sulphuric acid in petroleum refining	512	Tank vessel types	717
— regenerated	br. 3182, 3224, 5237, 5264, 5822, 6110, 6880, 8245, 8456	Tanks; dirt	717
— treatment of Russian oils	519	— oil storage	713-715
— utilisation of waste	513, 514	— specification for storage	667, 669
Sulzer-Diesel motor	br. 5820	(general)	br. 3655, 6206, 6416
Sumatra benzine	br. 2321	Tar; acid treatment	651
— crude oil	339	— Barbados	140
— distribution of petroleum in	215	— brown-coal, and its products	646-648
— Palembang Petroleum Co.	69	— from brown-coal; refining	649
— petroleum	br. 8367	— in Diesel engines; use of	br. 175
— fields in	68	— distillation	649-651
— production in	1083	— from lignite; production of, in Saxony	641
— products from crude petroleum from	291	— oil colours	651
— specific gravity and flashing-point of crude petroleum from	266	— oil-gas, from brown-coal oils	br. 7002
Summerland field, California	118	— in oil; separation and estimation of	br. 3974
Sunbury shale	br. 6280	— oils; determination of	br. 7930
— "Sunlight" lamp	895	— estimation of hydrocarbons in lignite	654
Sunning process	547	— from lignite; acid treatment of	651
Sunset field, California	121	— refining	850
Surakhani oil-field	br. 2682, 3415	— petroleum	br. 4723, 6730, 7765
— petroleum	br. 6255, 6309, 7269, 7288	— from petroleum residues	br. 1922, 5087
— physical properties of	285	— rock	br. 8013
Surface combustion; Bonecourt system of	1318	— and tar oils; import duties on, in various countries	1132 <i>et seq.</i>
Swabbing	470	Taranaki petroleum deposits, New Zealand	br. 8210
Swan, H. F.; tank steamers	680	Tarentum; gas and oil in the brine-wells of	85
Sweating processes for paraffin	637-641	Tasmania; Inflammable Oils Act, 1910	1011
Sweden; distribution of petroleum in	199	— occurrence of petroleum in	253
— import duties on mineral oils in	1150	— resinous shales of	br. 2725, 6402
— petroleum in	br. 8044	Tasmanite	br. 1334, 3776, 5599, 7372
— laws of 1875 and 1883	1046	Tataras asphalt mine	br. 3865
Sweet-water District, Wyoming	br. 2048	Tayabas oil-field	br. 3456, 6577
Swenson burner	956, 957	Tayuven, the Burmese digging tool	369
Switch and transformer oils	887	Tchatria oil-fields, Tiflis, in the	br. 3825, 5344
— dielectric strength and specific resistance	889	Tcheleken Island crude petroleum; specific gravity and flashing-point of	263
— for electrical purposes	887	— petroleum in	16
— flash-point of	888	(general)	br. 809, 1973, 3160, 3678, 3826, 3906, 3909, 3915, 3943, 4216, 4280, 6145, 6380, 6647, 7253, 7467, 8241
— physical properties of	889	Tegernsee petroleum	br. 4148, 4149, 6369
Switzerland; distribution of petroleum in	182	Tehuantepec Isthmus, Mexico; petroleum in	378
— import duties on petroleum products in	1150	Temper-screw	377, 378
— petroleum deposits in	43	Tennessee; oil-fields of	104
— regulations in	1047	— oil- and gas-fields; distribution of the	227
Synclines and oil	165, 166	— storage and testing regulations	1059
Syracuse; storage and testing regulations in	1056	(general)	br. 346, 4035, 4036, 5482, 6791, 6792, 6936, 8416
Syria; asphalt deposits in	187	Tennis-shoe makers in London; licensed using petroleum	992
— bitumen and asphalt in	br. 1562	Terek Province; oil and asphalt in	br. 106,
— petroleum in	br. 761	3839, 3997, 7850	
Szechuen "fire-wells," China	72	— petroleum deposits of the; historical	11
		— petroliferous deposits in the	202
		Terraces	654
		Terrace structure	165
		Terry, S. H., and F. Flannery; ventilating petroleum and other steamers	695

	PAGE		PAGE
Tervet, R.; shale-oil, examination of crude.....	877	Topeka; storage regulations .....	1052
— and F. Alison; paraffin cooling and sweating apparatus .....	639	Topping plant .....	137
Tervet deplegator .....	748	Torbanehill mineral .... <i>br.</i> 613, 2489, 2490, 2593, 3284, 4928, 5175, 6313, 6442, 6608, 7200, 7815, 8136	590
Test; Indiana State .....	766	Torbanite; mineral oil from .....	<i>br.</i> 6047
Testing affected by barometric pressure .... 776, 779, 789	777	Torpedo-boat destroyers; oil-burning ..	<i>br.</i> 7485
— by climate .....	875	Torpedo-boats; oil-fuel for .....	947
— neutrality of kerosene .....	1061	Torpedoes; oil-well .....	427, 428
— petroleum in different countries; methods of..	1019	Torpedoing wells .....	<i>br.</i> 8626
— French decrees as to .....	1026	Totomi, Japan; oil-fields of .....	75
— regulations of the Bremen Petroleum Exchange .....	1032	Toyah oil-field, Texas .....	<i>br.</i> 1775
— in India .....	1041	Transcaspia; petroliferous deposits in .... <i>br.</i> 864, 3932, 4188, 4190, 4192, 4948, 7182, 7919, 8779	208
— in Norway .....	983	Transcaspia Province; petroleum in the .....	16
— under the Petroleum Acts .....	809	Transcaucasia .... <i>br.</i> 1, 767, 1094, 1602, 5542, 6026, 7356, 8730	204
Test-tube method of ascertaining flash-point .....	327, 328	Transformer oils .....	<i>br.</i> 1018 .. 529, 887, 889
Tetracosane .....	311, 313	Trans-Kuban oil-field .....	<i>br.</i> 4409, 8740
— specific heat of .....	277	Transport of heavy oil in California .....	124
Tetratricontane .....	327	— of kerosene in the U.S. ....	668, 670
Texas asphalt-rock; composition of .....	335	— of natural gas .....	<i>br.</i> 2268, 6605, 6606
— asphaltum .....	<i>br.</i> 7963, 7964	— of petroleum .....	<i>br.</i> 2268, 6605, 6606
— crude oils; calorific values of .....	273	— of petroleum; early methods .....	655
— petroleum; specific gravities and flashing-points of .....	261	— in Mexico .....	673
— distribution of the petroleum fields in .....	235	— by rail .....	668
— geology of .... <i>br.</i> 1567, 1879-1886, 6573, 6634, 6635	113	— in Russia .....	674
— natural gas in .....	319	— in the U.K. ....	715
— petroleum in .... <i>br.</i> 58, 1118, 1779, 3089, 3363, 3952, 4785, 4786, 4842, 4852, 5309, 5310, 6019, 6061, 6080-6085, 6291, 6546, 7290, 7677-7679, 8142, 8143	312	— in the U.S. ....	655
— chemical nature of .....	113	— by water .....	670
— constituents of .....	312	Transval; occurrences of petroleum in the .....	252
— industry in .....	113	Transylvania .....	<i>br.</i> 837, 846, 4150, 4151
— production in .....	113, 1066, 1067	— rock-oil .....	<i>br.</i> 806, 5471
— specific heats of hydrocarbons from .....	278	Trenton Limestone; natural gas and oil from ..	107, 160
— storage regulations .....	1060	Treumann flash-point tester for lubricating oils ..	817
Texas Company's pipe-line .....	663	Tricosane .....	313
Texas-Louisiana Gulf Coast .... <i>br.</i> 2247, 2249	319	Tridecane .....	311, 313
Thallene .....	<i>br.</i> 5413	Trieste; regulations of the petroleum harbour ..	1012
Thames Conservancy bye-laws for petrol motor launches .....	1152	Trimethylene .....	308
— byelaws under the Petroleum Acts, 1871 and 1879 .....	1005	Trinidad asphalt .... <i>br.</i> 190, 775, 1556, 1564, 2713, 3119, 3276, 4775, 5017, 5100, 5484, 6102, 6426, 6506, 6551, 6646, 6715, 6802, 7808, 8731	332, 333
— specification for tank barges .....	1005	— asphalt; comparison of, with Cuba and Bermudez asphalts ..	332
Thibet; distribution of petroleum in .....	214	— composition of .....	331
Thionaphthene of brown-coal tar .....	<i>br.</i> 855	— bitumens; characters of, at different temperatures .....	880
Thiophene in petroleum .....	304	— danger from rain .....	143
Thomas; explosion on the ship .....	697	— distribution of the petroleum deposits in .....	247
Thomson, J. H., and B. Redwood; metal polish, flash-point test of liquid .....	774	— exports of asphalt from 1899-1918 .....	1125, 1126
— petroleum spirit, test for volatility of .....	753	— general account of oil-fields .....	247
Thorndike; explosion on the ship .....	697	— geology of .... <i>br.</i> 1164, 1165, 1517, 1557, 2015, 2256, 2716, 8138, 8140	144
Thorn's ozokerite extractor .....	563	— oil facilities .....	144
Thörner; kerosene, fractionation of .....	758	— oil-fields .... <i>br.</i> 1518-1526, 1895, 2145, 2711, 3043, 3275, 6745, 6746	141
Thornycroft burner .....	958, 959	— petroleum in .....	141
Thum, C. F., <i>see</i> Hill, S. A. ....	489	— pitch-lake .... <i>br.</i> 1556, 5017, 5484, 5698, 5988, 6001, 7280, 7773, 7807	141
Thuringia; petroliferous deposits of .....	148	— history of the .....	141
Thurston, R. H.; friction-testing .....	833	— production of asphalt in, 1903-1913 .....	1125
— lubricant; characteristics of an efficient .....	844	— production of crude oil in .....	1095
— tester .....	846, 847	— specific gravity and flashing-point of crude petroleum from .....	266
Thwaite, B. H.; tank steamers .....	685	— and Tobago; import duties on petroleum products .....	1150
Thwaite oil-gas plant .....	923	— Petroleum Ordinance .....	1049
— producer-gas plant .....	928, 929	Trinidad Oil-Fields, Ltd. ....	143
Tide-water pipe-line .....	659	Triolein; preparation of hydrocarbons from .....	357
Tiflis Province; petroleum deposits in the. <i>br.</i> 861, 3557, 3842, 4107	16, 204	<i>Triumph</i> ; explosion on H.M.S. ....	697
<i>Tilbury</i> ; explosion on the barge .....	697	Trusty oil-engine .....	971
Tilsenburgh oil-field, Canada .....	79	Tubing spears and sockets .....	385
Timor; distribution of petroleum in .....	216	Tunis; distribution of petroleum in .....	185
— petroleum in .....	71	— import duties on mineral oils and wax .....	1151
— specific gravity and flashing-points of crude petroleum from .....	266	— petroleum .....	<i>br.</i> 2934
Tins for carrying kerosene .....	673	— specific gravity and flashing-point of crude petroleum of .....	265
Tintometer, the .... <i>br.</i> 4777	813	Turbine lubricating oils .....	855
Titicaca oil-field, Peru .....	151	— oil; testing .....	<i>br.</i> 3752
Tobago, <i>see</i> Trinidad.	923, 924	Turfa .....	145, 250
Tocher, J. F.; oil-gas, production of .....	923, 924	Turkestan .... <i>br.</i> 52, 4609, 5282, 5502, 5503, 6333, 6666, 6667, 6755, 8096	214
— enriching oil-gas .....	952	Turkey; asphalt production in, 1901-1909 .....	1126
Togoland; import duties on petroleum products..	1150	— distribution of petroleum in .....	187
Tokio petroleum regulations .....	1037	— import duties in petroleum products .....	1151
Toluene in petroleum .....	315		
Toluol .....	293		
Tool-joint wrenches .....	390		

	PAGE		PAGE
Turkey; petroleum in . . . <i>br.</i> 76, 932, 1801, 2111, 2160, 3088, 3246, 5099, 7305	54	United States; value of natural gas produced in the, 1911-1918 . . . . .	1100
— petroleum storage regulations in . . . . .	1151	— yield of petroleum products in Eastern . . . . .	546
Turk's and Cocos Islands; import duty on mineral oil . . . . .	1151	— (general) . . . <i>br.</i> 444, 611, 877, 971, 1121, 1311, 1605, 1652, 1660, 1662, 1663, 2967, 2968, 6591, 8686	
"Turpentine" . . . . .	886	United States Oil Company . . . . .	89
Turpetine oil; oil-gas yielded by . . . . .	926	Unmined supply of petroleum in the U.S. . . . .	92, 94, 222
— and substitutes; estimation of petroleum products in . . . <i>br.</i> 1126, 1498, 1499, 1966, 2432, 5612, 7923, 7961		Ural Mountains; petroliferous deposits in . . . . .	200
— substitutes; Import duties on, in Australia . . . . .	1133	— <i>br.</i> 4492, 7312, 7818	
— from mineral oils . . . . . <i>br.</i> 6847	886	Uralsk Province; petroleum deposits in the . . . . .	17, 207
— from petroleum spirit . . . . .	335	— <i>br.</i> 77, 5693	
Turrellite, an asphalt rock from Texas . . . . .	183	Urquhart's ostakti burner . . . . .	951, 952
Tuscany . . . . . <i>br.</i> 48		Uruguay; import duties on petroleum products in Uses of petroleum and its products . . . . .	883
Tyrol; petroliferous deposits in the . . . <i>br.</i> 762, 763, 6090, 6091, 6332, 6739, 7259	195	Ustrzyki district, Galicia; specific gravities of crude petroleum of the . . . . .	263
UCHTA oil-field . . . . . <i>br.</i> 6178, 7852, 7938, 8640	18	Utah; distribution of the petroliferous deposits of — oil and natural gas in . . . . .	241
— naphtha discovery at . . . . . <i>br.</i> 8184		— ozokerite . . . . . <i>br.</i> 4907, 4963	128
Uganda; import duty on petroleum products in . . . . .	1151	— testing petroleum in . . . . .	1060
Uнтаhite or uнтаite . . . <i>br.</i> 782, 783, 1988, 1989	329	— (general) . . . <i>br.</i> 457, 951, 1737, 4963, 6005, 6569, 6571, 6637, 7048, 7432, 7575, 8524, 8646	
(See also Gilsonite.)		VACUUM distillation . . . . .	507
Under-reamer; "Express" . . . . .	460	Vacuum Oil Company . . . . . <i>br.</i> 3346	
— Fauck's . . . . .	456	Val de Travers asphalt . . . . . <i>br.</i> 690, 927, 1298, 1746-1748, 2393, 3322, 3684, 3685, 3690, 4122, 4346, 5176, 7906	
Under-reamers used in Galicia . . . . .	451	— asphalt-rock; composition of . . . . .	334
— Russian . . . . .	439	"Valuation figure" . . . . .	932
United Kingdom; early legislation as to flash-point in the . . . . .	763	Valve-rope knife . . . . .	384
— oil-shale production in the, 1873-1919 . . . . .	1127-1129	Valve; pressure and vacuum relief for tanks in vessels . . . . .	685
— pipe-line . . . . .	679	Van der Heyden, T.; petroleum, solidification of Van Friesland; "aerogene gas" system . . . . .	919
— production of crude oil in the . . . . .	1094	Van Syckles, S.; distilling apparatus . . . . .	490
— and value of natural gas in the . . . . .	1112	Vaporisation; heat of . . . . .	280
United Pipe-Lines specification for a 35,000-barrel tank . . . . .	667	Vaporiser; Priestman . . . . .	968, 969
United States; asphalt production in the, 1898-1918 . . . . .	1124	Vapour density; estimation of . . . . . <i>br.</i> 1976	
— development of the petroleum industry in the . . . . .	87	— testing apparatus; Philip and Steele's . . . . .	813
— distribution of petroleum in the . . . . .	221, 222	— — — Redwood's . . . . .	809-812
— drilling-plant used in the . . . . .	375	Varnish from bitumen . . . . .	886
— early legislation as to flash-point in the . . . . .	764	— making; testing asphalt for . . . . .	880
— production of petroleum in the . . . . .	89-91	— substitutes . . . . . <i>br.</i> 212	
— exports of crude petroleum and products from the, 1903-1918 . . . . .	1075-1078	Vaseline; bromine test of . . . . .	868
— of petroleum products from . . . . .	1069	— chemical tests of . . . . .	877
— fire-test for lubricating oils . . . . .	818	— composition of Galician . . . . .	532, 533
— gas-fields of the . . . . .	96-98	— and properties of . . . . .	326
— gas industry, development of . . . . .	98, 432	— distillates; melting-points of . . . . .	533
— Government fuel-oil specifications . . . . .	860	— paraffins in . . . . .	534
— import duty on petroleum products in . . . . .	1151	— import duties on, in various countries . . . . .	1132 <i>et seq.</i>
— leases on oil properties in the . . . . .	373	— oils; characteristics of Galician . . . . .	532, 533
— manufacture of lamp-black in the . . . . .	939	— oxidation of . . . . .	537
— of oil from coal and shale in the . . . . .	87	— preparation of . . . . .	532
— methods of crude oil distillation . . . . .	477	— solid and liquid constituents of . . . . .	534, 535
— of producing petroleum in the . . . . .	371	— testing . . . . .	743, 744, 877
— natural gas in the . . . <i>br.</i> 335, 338-342, 3060-3062, 7871, 8521, 8687		— uses of . . . . .	883
— gas-wells; record of, 1917-1918 . . . . .	1101	— viscosity of . . . . .	536
— naval liquid-fuel tests . . . . .	947, 948	— and vaseline oil . . . <i>br.</i> 57, 728, 1328, 1696, 2091, 2431, 2624, 2626, 2633, 4252, 4404, 4730, 4849, 5130, 5305, 5421, 6573, 7362, 8032, 8118, 8283	
— oil-fields of the . . . <i>br.</i> 2950, 3264, 3450, 4035, 6448, 6453, 7871, 8005, 8368		Vegetable matter; theory of formation of petroleum from marine . . . . .	358
— oil- and gas-fields . . . . .	222	Vegetation; origin of petroleum from terrestrial . . . . .	351
— oil and gas production . . . . .	430	Veith; calorific values of various petroleum . . . . .	276
— oil-yielding shale . . . . .	606	— petroleum ether . . . . .	267
— petroleum industry in the . . . <i>br.</i> 3813, 4496, 4582, 5420, 6104, 6576, 7516, 7628, 8785		— formation of, from olefine . . . . .	357
— — in the; historical . . . . .	85	Venango, U.S.A.; oil-fields of . . . <i>br.</i> 1026, 1928, 3086, 5546	85
— — production and consumption . . . . .	97	Venezuela; asphalt exports from . . . . .	1127
— — refineries . . . . .	547-554	— from, 1904-1918 . . . . .	1127
— — refining in the . . . . .	538	— bitumen; characters of, at different temperatures . . . . .	880
— — regulations in the . . . . .	1050	— distribution of the petroliferous deposits in . . . . .	249
— — unmined supply in the . . . . .	92, 94, 222	— import duties on petroleum products . . . . .	1151
— pipe-line (Emery line) . . . . .	658	— oil output . . . . .	145
— principal oil-fields of the . . . . .	99	— petroleum and asphalt deposits in . . . . .	144
— production of crude petroleum in, from 1875-1918 . . . . .	1066	— specific gravity and flashing-point of crude petroleum from . . . . .	262
— of natural gas in the . . . . .	932	— (general) . . . <i>br.</i> 909, 2374, 3379, 5016, 6156-6158, 8331	
— railroads; consumption of fuel-oil by . . . . .	1079	Ventilation of tank-steamers . . . . .	684, 695, 713
— railways; use of oil-fuel in the . . . . .	946	Ventura County, California; oil-wells in . . . . .	123
— refinery; description of a . . . . .	544	Vermont; storage and testing regulations . . . . .	1060
— storage of crude petroleum in the . . . . .	666		
— tank cars used in the . . . . .	668		
— transport of petroleum in the . . . . .	655		
— unmined supply of petroleum . . . . .	92		
— use of liquid fuel in glass and ceramic industries in the . . . . . <i>br.</i> 128			

	PAGE		PAGE
Vessels fitted for liquid fuel; list of . . . . .	725	Washington; testing petroleum in . . . . .	1060
— oil . . . . .	<i>br.</i> 1516, 1573, 3424, 5095, 5096, 5378	Waste acid and alkali; utilisation of . . . . .	513
( <i>See also</i> Steamers and Ships.)		Water in crude petroleum; determination of . . . . .	744
Vette's flash-point tester . . . . .	806	— extractor for storage tanks . . . . .	678
Victoria; occurrence of petroliferous deposits in . . . . .	253	— finder for storage tanks . . . . .	720
"Victoria" lamp . . . . .	902	— flush drilling methods . . . . .	460, 466
Victor Meyer's flash-point instrument . . . . .	906	— level gauge for storage tanks . . . . .	678
— Haass's modification . . . . .	796	— in oils; estimation of . . . . .	<i>br.</i> 585, 1574, 2750, 5969, 4308, 5033, 6552
Vieux Jardin, Algeria; petroleum deposits at . . . . .	48	— in paraffin; determination of . . . . .	864
<i>Ville de Calais</i> ; explosion on s.s. . . . .	699	— from petroleum refining; purifying waste . . . . .	<i>br.</i> 1809, 8358
Virgin Is.; import duties on petroleum products . . . . .	1151	— In petroleum residuum; determination of . . . . .	868
— storage and testing regulations . . . . .	926	"Water" safety-lamp; Devoll's . . . . .	903
Viridine from distillation residues . . . . .	1060	Water-gas; carburetted . . . . .	927
Viscometer, comparison between Redwood's and Barbey ixiomètre . . . . .	839	— process of making . . . . .	928
Viscometers; comparison of Kunkler's and Engler's — of Redwood, Engler, and Saybolt . . . . .	838	Waterproof garment makers in London; licensed, using petroleum . . . . .	993
— conversion table . . . . .	832	Waterproofing; use of petroleum in . . . . .	<i>br.</i> 7363
— for greases . . . . .	830	Wax; analysis of . . . . .	<i>br.</i> 604, 2053
Viscometers for lubricating oils:—		— import duties on mineral, in various countries, . . . . .	1132 <i>et seq.</i>
Albrecht . . . . .	819	— mineral . . . . .	<i>br.</i> 497, 607, 635, 851, 1078, 1082, 1108, 1797, 3026-3028, 3385, 3855, 4170, 4266, 6444, 7049, 7538, 7539, 8591, 8592
Arvine . . . . .	838	— paraffin . . . . .	60, 76, 327
Barbey . . . . .	839	( <i>See also</i> Ceresin and Paraffin Wax.)	
Bubble system . . . . .	840	Weeks; gas-fields of the U.S. in 1890 . . . . .	96
Cockrell . . . . .	840	Wegelin-Hübner ozokerite extractor . . . . .	564
Coleman-Archbutt . . . . .	822	Weichowite . . . . .	<i>br.</i> 5198
Doollittle . . . . .	841	Well record, Dennis well, Bradford, Pa. . . . .	391
Engler . . . . .	826, 832, 833, 834	— of the Lucas well, Texas . . . . .	403
Engler-Kunkler . . . . .	834	Wells affected by weather . . . . .	73
Gibbs . . . . .	840	Wells; affidavit as to abandoned . . . . .	421
Kunkler . . . . .	834	— bailing, in Russia . . . . .	446
Lamansky-Nobel . . . . .	827	— in the Baku district; diameter of the, in 1903 . . . . .	438
Lepenau . . . . .	839	— broken up by earthquakes . . . . .	37
Martens . . . . .	834	— Burnese method of sinking, and its cost . . . . .	369, 370
Mason . . . . .	822	— cementing . . . . .	409, 412, 413
Napier . . . . .	822, 840	— Chinese method of sinking artesian . . . . .	366
Nasmyth . . . . .	819	— controlling outflow of, in Russia . . . . .	445
Phillips . . . . .	819	— depth of American . . . . .	394
Pipette . . . . .	821	— of Russian . . . . .	442
Redwood . . . . .	823	— estimating the production of gas . . . . .	429
— Admiralty pattern . . . . .	825	— gas, in the U.S. . . . .	428
Redwood and Saybolt . . . . .	828-830	— in the Grozni field; particulars of the . . . . .	1081
Saybolt . . . . .	828	— inducing flow in . . . . .	420
Viscometers for small samples . . . . .	836	— Japanese method of sinking petroleum, and its cost . . . . .	365, 366
— for use at low temperatures . . . . .	834	— lining, with cement . . . . .	<i>br.</i> 871, 1712
— (general) . . . . .	<i>br.</i> 1815, 2068, 2100, 4287, 7865, 7866, 8444	— methods of drilling, in Galicia . . . . .	448, 449
Viscosimeter; Saybolt Universal . . . . .	828, 829	— offsetting . . . . .	<i>br.</i> 3769
Viscosity; absolute . . . . .	831, 832	— pressing in, and its cause . . . . .	170
— Bubble system of determining . . . . .	840	— in Russian . . . . .	443
— of lubricating oils; determination of . . . . .	819	— productivity of . . . . .	<i>br.</i> 3446
— of mineral oil; Scottish method of testing . . . . .	864	— pumping . . . . .	420
— of petroleum . . . . .	295	— rate of progress in boring . . . . .	397
— test of lubricating oils; value of the . . . . .	842	— in Rumania; condition of the, in 1916 . . . . .	1086
— testing . . . . .	<i>br.</i> 1019, 1322, 1423, 1942, 2059, 2101, 3005, 3499, 3901, 4073, 5135, 5545, 5737, 6452, 7092, 7167, 7171, 7353, 7367, 7869, 7905, 8309	— spacing of . . . . .	375
Volatility of oils; estimation of the . . . . .	<i>br.</i> 3483	— torpeding . . . . .	425, 428
— test of lubricating oils . . . . .	818	— yield of American . . . . .	419
Volga oil, asphalt, etc. . . . .	<i>br.</i> 6657	— of, in Russia . . . . .	443
Vologda Province; petroleum deposits in . . . . .	18, 200	— (general) . . . . .	<i>br.</i> 2141, 5847, 7834
Von Boyen, E.; ceresin or refined ozokerite, manufacture of . . . . .	565	"Wells" lamp . . . . .	907-909
Vulcan oil . . . . .	<i>br.</i> 4750, 5829	Western Australia; natural gas in . . . . .	<i>br.</i> 5014
WAGES of Burmese well-diggers . . . . .	370	— occurrences of petroleum in . . . . .	253
Waggon stills . . . . .	481	West Indies; distribution of petroleum in the . . . . .	246
Wairarapa North County, N.Z.; occurrence of oil in . . . . .	154	Westinghouse gas regulator . . . . .	933
Wallachia; petroleum in . . . . .	<i>br.</i> 1084, 1222	Weston's carburetor . . . . .	915, 916
Wanklyn and Cooper; distillation apparatus . . . . .	507	Westphalia; petroleum and asphalt in . . . . .	<i>br.</i> 558, 5462
"Wanzer" lamp . . . . .	895	— petroliferous deposits in . . . . .	197
Warner, W.; paraffins from Pennsylvania petroleum . . . . .	312	Westrum; road-sprinkling with "soluble oil" . . . . .	886
— petroleum from Sumatra and Cebu; products from . . . . .	291	"Westrumite" . . . . .	886
Warren district oil-fields, U.S.A. . . . .	99, 100	West Virginia; distribution of oil-fields in . . . . .	225
Warsaw asphalt works . . . . .	<i>br.</i> 6499	— natural gas in . . . . .	<i>br.</i> 8316, 8319, 8326
Warships; oil-fuel for . . . . .	<i>br.</i> 1363	— oil-fields of . . . . .	<i>br.</i> 888, 987, 988, 1791, 2142, 2348, 2841, 2842, 7086, 8190, 8319, 8326, 8414, 8735
Washer; Grey Typhoon . . . . .	525	— petroleum production in . . . . .	1066, 1074
Washing-machines for mineral oils . . . . .	<i>br.</i> 2478, 3702	— pipe-lines in . . . . .	661
Washing petroleum after acid treatment . . . . .	519	— record of the natural-gas industry in, 1897-1910 . . . . .	1104
Washington crude petroleum; specific gravities of . . . . .	260	Wetoy Island (Holy Is.) petroleum; historical account . . . . .	4, 11
— distribution of petroleum in . . . . .	243	"Wet" gas . . . . .	342
— district; oil-fields of the . . . . .	101, 128	Weygang; petroleum product mixable with water . . . . .	885

	PAGE		PAGE
Weymouth, O. R.; oil-firing losses and their avoidance .....	962	Wyoming petroleum resources .....	125
Wheelrite .....		— minerals in .... <i>br.</i> 565, 566, 1987, 2310, 2311, 3724, 3725, 4130-4139, 7001, 7968, 7969	
White, I. C.; gas-wells of western Pennsylvania and West Virginia .....	165	— oil-fields of .....	124
— oil; yield of, from rock .....	420	— petroleum production in .....	1066, 1067
Whitehaven; petroleum from .....		— storage and testing regulations in .....	1061
Whittier oil-field .....			
Wick-tester for kerosene; Redwood's .....	759, 760	XYLENES in petroleum .....	315
Wicks; lamp .....	903	“Xerotine sicative” .....	697
Wiederhold; rosin oil, detecting and estimating in mineral oil .....	876		
Wietzno; oil-fields of .....		YANKTON, S.D.; storage regulations in .....	1059
Wietze petroleum district, Prussia .....	37	Yarrow's "Zephyr" launch engine .....	977
Wigan; petroleum deposits near .....	39, 42	Yenangyaung and Yenangyat oil-fields, Burma ..	61
Wilcox spouting water-well .....		Yenchang, China; oil-wells at .....	73
Wild assertion about underground lakes of oil ..	167	Yesso .....	<i>br.</i> 781
<i>Wild Flower</i> ; explosion on the s.s. ....	698	Yield of wells in America .....	419, 420
Willesden; occurrence of petroleum at .....	41	Young, J.; distillation process .....	579
Wilson chromometer .....	761	— shale-oil industry .....	589
“Winged substitute” .....	377	Young, S.; dephlegmator .....	748
Wisconsin; distribution of the petroliferous deposits in .....	233	— hydrocarbons in American petroleum .....	314
— natural gas in .....	127	Young, W., and G. Beilby; shale-oil distillation, 611, 613, 617	
— State tester .....	798	— and A. Bell; oil-gas system .....	930
— storage and testing regulations .....	1060	— and P. Brash; shale retort, intermittent .....	613
Wolongonite .....		— and J. Fyfe; shale retorts .....	618, 620, 621
Wool preservation .... <i>br.</i> 74, 3316, 4984, 6557, 7613, 8271		Young; saturated hydrocarbons; physical properties of the .....	317
Woodbury, C. H. J.; lubricating oils, friction tests for .....	845, 846	Young's paraffin works .....	<i>br.</i> 4801
— lubricant tester .....	847	Yukon; occurrence of petroleum in .....	217
Wool grease oleines; detection of mineral oil in ..			
World's production of petroleum, 1916, 1917, 1918	1096-1098	ZALA county, Hungary; oil-wells in .....	25
Worthington, H. R.; pump for forcing oil through pipe-lines .....	665	Zaloziecki; hydrocarbons in petroleum, etc., estimation of solid .....	879
Woznesensk; petroleum in .... <i>br.</i> 7314, 7317		— petroleum; animal origin of .....	358
Wrenches; tool-joint .....	390	Zante; specific gravity and flashing-point of crude petroleum from .....	265
Württemberg; petroliferous deposits in .....	196	— tar-wells of .....	36, 188
— State Railways; lubricating oil specification ..	859	— (general) .....	<i>br.</i> 4412, 5905, 7464
Wurzilite .....	128	Zanzibar; import duty on petroleum products ..	1151
Wyoming crude petroleum; specific gravities and flashing-points of .....	260, 261	— storage regulations in .....	1061
— distribution of the oil-fields in .....	239	Zaravshan; petroliferous deposits in .....	207
— gas- and oil-fields .... <i>br.</i> 368, 369, 370, 371, 400, 1440, 1604, 1606, 1608, 1609, 1610, 1826, 3164, 3343, 4358, 4390, 5607, 6437, 7000, 7081, 8253, 8254, 8486		Zempen; geology of .....	<i>br.</i> 6970
		“Zephyr” launch engine .....	977
		Zinc ores; use of crude oil for reducing. <i>br.</i> 3579	52
		Zohab, Persia; petroleum deposits at .....	149
		Zorritos oil-field, Peru .....	1090
		— production of petroleum in the .....	1049
		Zürich; petroleum regulations in .....	1049

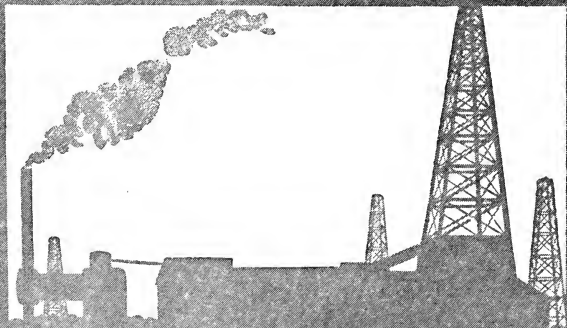

**"OILWELL"**

ESTD

1862.



TRADE

MARK

(REGISTERED)

**EVERYTHING SUPPLIED TO DRILL AND  
EQUIP OIL, GAS AND WATER WELLS.**

**OILWELL SUPPLY Co.**

EUROPEAN OFFICE—

**DASHWOOD HOUSE, LONDON, E.C.2.**

HEAD OFFICE—

**PITTSBURGH, U.S.A.**

**BRITISH MANNESMANN  
WELDLESS STEEL TUBING.**

---

**MADE FROM HIGH TENSILE STEEL**

**35/40 TONS per Sq. Inch.**

**For**

**WELL BORING.**

**DRIVE PIPE.**

**DRIVE HEADS & SHOES.**

**CASING.**

**ROTARY DRILL PIPING.**

**ROCK BORING RODS.**

**LINE PIPE, ETC.**

---

**THE**

**BRITISH MANNESMANN TUBE**

**CO. LTD.**

**SALISBURY HOUSE, LONDON WALL, E.C.2**

Telegrams: TUBULOUS, AVE., LONDON

Telephone: 4610 LONDON WALL

—THE—  
**Petroleum Times**

PUBLISHED WEEKLY.

39/- PER ANNUM (POST FREE) THROUGHOUT THE WORLD.

**The International  
Petroleum Journal**

“The Petroleum Times” (founded and edited by ALBERT LIDGETT) is the most influential and widely circulated petroleum journal printed in the United Kingdom.

*For the Oil Man and the Oil Investor  
“The Petroleum Times” is invaluable.*

**Correspondents throughout the  
World.**

Telegrams :  
“Petrofield, London.”

Phone :  
Central 6648.

Editorial and Publishing Offices :  
**4 Broad Street Place,  
London, ————— E.C. 2.**

*America : 120 Broadway, New York, U.S.A.*

*Germany : 59/60 Friedrichstr., Berlin.*





BY APPOINTMENT

# ANGLO-AMERICAN OIL CO. LTD.

## PRATT'S PERFECTION SPIRIT

The high-grade motor spirit of consistent quality, producing maximum power with clean combustion. The same standard of purity from the Golden Pump or the sealed Green Can.

## PRATT'S AVIATION SPIRIT

At the International Air Service Station at Waddon 80% of the Aviation Spirit used by British and Continental Air Travel Companies is Pratt's "Aviation"—outstanding proof of its dependability.

## ANGLO'S FUEL OIL

For Bunkers, Diesel Engines, Heating (Furnaces), Power-driving, etc. Maximum pressure of steam can be obtained in minimum time, and full pressure maintained at constant level for any length of time.

## ANGLO'S VAPORISING OIL

The Official Fuel used at the Lincoln Tractor Trials. Gives maximum power, clean combustion and reliability for all descriptions of power-driving in connection with the Farm.

## ROYAL DAYLIGHT OIL

Clean and bright-burning, with high-power illuminating qualities, it is everywhere the oil of domestic use for lighting, cooking, and heating.

ETC., ETC.

**HEAD OFFICE: 36 QUEEN ANNE'S GATE, LONDON, S.W. 1**

**Branches and Depots Everywhere**

PATENT  
**GRIPOLY  
BELTING**

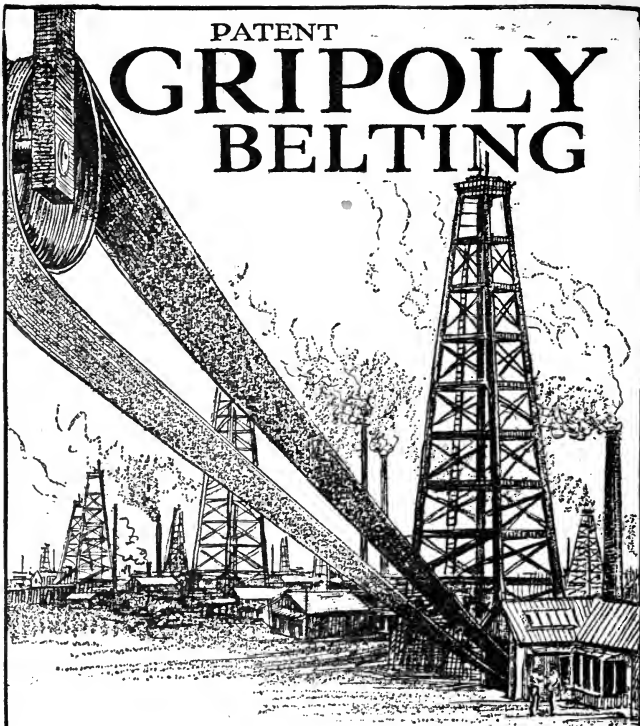

STANDARDISED BY THE  
LARGEST OIL COMPANIES  
THE SUPER BELT FOR  
OILFIELD WORK  
—AND IT COSTS NO MORE

Illustrated Booklet free on request

**LEWIS & TYLOR, LTD.**

9 ST THOMAS' STREET, LONDON, S.E.1

Works: GRANGE MILLS, CARDIFF

Branches and Stock Service Depots in the Colonies, and in all  
Principal Countries Abroad.

# OILS

*for every Power Purpose*

**PETROLEUM PRODUCTS**

*of the Highest Grade*

MOTOR **BP** SPIRIT

**DIESEL OILS**

**KEROSENE**

**FUEL OIL**

**CAS OIL**

**P.V.O.**

FOR OIL ENGINES

**T.V.O.**

TRACTOR VAPOURISING OIL

In any Quantities via Road, Rail, or Water:

**BRITISH PETROLEUM Co LTD**  
**22 FENCHURCH STREET LONDON EC3**

# **SEABOARD OIL** **CORPORATION**

**High - Grade Petroleum Lubricants.**

**Neutrals.          Cylinder Oils.**

**Mineral Colza.**

**Red and Pale Paraffin Oils.**

**Paraffin Waxes.      Petroleum Jellies.**

---

**GASOLINE.      KEROSENE.**

**FUEL OIL.**

**Bulk and Barrels.**

**DASHWOOD HOUSE,  
LONDON.**

**11 BROADWAY,  
NEW YORK.**

# MODERN OIL PLANT

*Complete Plants supplied for*

RETORTING Shale, Hard and Soft Coals, etc.

DISTILLING Crude Oil, Asphalt, Bitumen, etc.

DEBENZINATING Crude Oil.

DEBENZOLISING Coal Gas.

CRACKING for Petrol.

COKING for Carbon.

WASHING Benzine, Kerosine, etc.

EXTRACTING Paraffin Wax.

DEHYDRATING Oil Tar, etc.

LIQUEFYING Oil Gas, etc.

## STANDARD

STILLS

CONDENSERS

DEPHLEGMATORS, TANKS, etc.

Send for Catalogue,  
SECTION 10 B.R.

# W. J. FRASER & CO. LTD.

ENGINEERS

DAGENHAM.

ESSEX.

# OIL FUEL

THE FUEL OF THE 20th CENTURY

*Efficiency.*

*Economy.*

*Cleanliness.*

## The Asiatic Petroleum Co. Limited

ST HELEN'S COURT, GREAT ST HELEN'S, LONDON, E.C. 3

CAN ARRANGE SUPPLIES OF

**OIL FUEL for MOTOR SHIPS, STEAMERS' BUNKERS,  
and INDUSTRIAL PURPOSES, at**

Adelaide	Curaçao	Miri	Saitozaki
Alexandria	Gemshah	Mombasa	Salina Cruz (Pacific)
Amsterdam	Genoa	Montevideo	San Francisco
Antwerp	Glasgow	Montreal	San Pedro
Aomori	Granton	Nagasaki	Santos
Avonmouth	Hankow	Naples	Seattle (Washington)
Augusta (Sicily)	Havana	New Orleans	Shanghai
Balboa (Panama Canal)	Hong Kong	New York	Singapore
Balik Pappan	Hull	Palembang	Soerabaya
Bangkok	Hurghada	Palermo	Southampton
Barcelona	Karachi	Pangkalan Berandan	Spezia
Barrow	La Guayra (Venezuela)	Penang	Stockholm
Barton (Manchester Ship Canal)	Las Palmas	Perim	Suez
Batavia	Leghorn	Pernambuco	Sydney
Bilbao	Liverpool	Piræus	Svolvaer
Boelebaai Ceram	Lisbon	Portland (Oregon)	Tampico
Bombay	London (Shell Haven Thames Haven)	Port Said	Tarakan
Buenos Ayres	Macassar	Port Sudan	Trieste
Calcutta	Madras	Pulo Bukom	Trinidad
Canton	Malmö	Puloe Samboe	Tuxpan
Cape Town	Malta	Rotterdam	Valparaiso
Christiania (Soon)	Manila	Rouen	Vancouver
Civitavecchia	Maracaibo (Venezuela)	Rio de Janeiro	Venice
Colombo	Marseilles	Sabang	Vera Cruz
Colon (Panama Canal)	Melbourne	Saigon	Yokohama

**And New Stations are expected to be ready shortly at**

Antofagasta	Dunkirk	Havre	Port St Louis du Rhone
Bordeaux	Durban	Ilo Ilo	San Juan (Porto Rico)
Cebu	Funchal (Madeira)	Iquique	St Vincent
Constantinople	Gothenburg	Jarrow-on-Tyne	St Nazaire
Copenhagen	Hamburg	Port Louis	Vado

BUYERS desiring information regarding supplies of and price for **Oil Fuel** for use in Internal-combustion Engines or for other purposes should apply to **The Asiatic Petroleum Company, Ltd.**, at the above address.

THE Asiatic Petroleum Company also supply **Kerosene Oil** for use in the smaller Internal-combustion Engines, and are prepared to supply **Petroleum Spirits, Lubricating Oils, Wax, and Greases** in all Far Eastern Markets.

# The Whessoe Foundry & Engineering Co. Ltd.

Works: Darlington.

London Office: 106 Cannon St., E.C. 4.



THE LEADING MAKERS OF  
**OIL STORAGE TANKS**  
OF ALL CAPACITIES.

---

*Also Refinery Plant, Rivetted Steel Piping, Structural  
Steel & Iron Work, etc. etc.*



**T**AKEN from an actual photo of a trip spear with mechanic alongside for comparison of size. This is for 21 inch O.D. drive pipe. We have facilities for producing the heaviest tools required.

---

THE  
**OIL WELL ENGINEERING CO. LTD.**

Works:  
**CHEADLE HEATH, STOCKPORT**

---

The largest Manufacturers of Oil Well Drilling Plant and Oil Well Supplies in the British Empire.



# STEEL PIPES

FOR  
OIL FIELDS AND REFINERIES

PIPE LINE  
BORING AND CASING TUBES

Inserted Screwed Joints, Rounded Sockets, Shoes,  
Caps, etc., Steam Pipes, Loose Flange Pipes,  
Fittings of all kinds, Steel Plates, Steel Castings.

**STEWARTS AND LLOYDS, LIMITED.**  
GLASGOW                      BIRMINGHAM                      LONDON

**BAIRD & TATLOCK (LONDON) LTD.**

*Manufacturers of*  
**APPARATUS FOR TESTING  
OILS AND PETROLEUM**  
(Complying with Board of Trade Specification)

*Catalogues Free  
on Application*

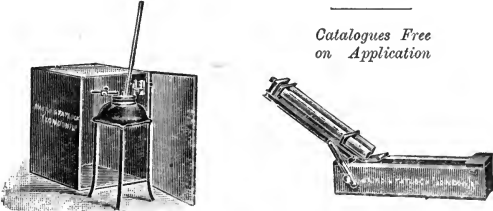

Factory - Higham Lodge - Walthamstow

**14-15 CROSS STREET HATTON GARDEN LONDON E.C.1**

N  
A  
T  
I  
O  
N  
A  
L



N  
A  
T  
I  
O  
N  
A  
L

*By courtesy of The Oil Fields Ltd.*

The first Rotary in England. Supplied by the  
National Supply Corporation.

## **THE NATIONAL SUPPLY CORPORATION**

and its associates are the

**LARGEST MANUFACTURERS OF OILFIELD MACHINERY  
AND TOOLS IN THE WORLD**

Percussion Outfits	Rotary Outfits	Combination Outfits
"Clark" Drilling Engines	"Ideal-Ajax" Single & Twin Cylinder Steam Engines	
Petrol Extraction Plants	Shaft-driven Rotaries	"National Tube" Pipe
Oil Storage Tanks	Oil and Gas Engines	Oil Refining Plants

**TECHNICAL CONSULTATIONS FREE**

## **THE NATIONAL SUPPLY CORPORATION**

European Office:—165 QUEEN VICTORIA St., LONDON E.C. 4

New York Office:—120 BROADWAY, NEW YORK, U.S.A.

Offices in all the important Oil Centres of the World.

The only Complete Series of  
OIL JOURNALS in the World.

# PETROLEUM WORLD

---

---

*(Monthly ; Green Cover.)* 12/- per year, post free.

## OIL NEWS

---

---

Weekly—Illustrated.

*Post Free :*

17/6 per year at home,

£1 per year abroad.

*(Weekly ; Tinted Cover.)*

## DAILY OIL BULLETIN

---

---

*(Every Day at Noon.)*

**SPECIMEN COPIES FREE.**

---

32 GREAT SAINT HELENS,  
LONDON, E.C. 3.

Telephone:  
CITY 8424.

Telegrams:  
GUAYARE, STOCK, LONDON.

---

**PUBLISHERS AND SUPPLIERS  
OF ALL BOOKS ON OIL.**



Oil and "Oilwell" have grown up together.

# **OIL WELL SUPPLY CO.**

**THE OLDEST AND LARGEST MANUFACTURERS OF  
OILFIELD EQUIPMENT.**

**EVERYTHING SUPPLIED AS  
REQUIRED FOR DRILLING OIL,  
GAS, AND WATER WELLS, ANY  
SIZE, ANY DEPTH, ANYWHERE.**

**DASHWOOD HOUSE,  
LONDON, E.C. 2.**



UNIVERSITY OF CALIFORNIA, LOS ANGELES

THE UNIVERSITY LIBRARY

printed below

University of California  
SOUTHERN REGIONAL LIBRARY FACILITY  
405 Hilgard Avenue, Los Angeles, CA 90024-1388  
Return this material to the library  
from which it was borrowed.

DATE DUE

OCT 16 1995

SELF  
QUARTER LOAN

RECEIVED

JUN 19 1995

EMIL LIBRARY

UNIVERSITY OF CALIFORNIA  
AT  
LOS ANGELES  
LIBRARY



A 000 583 569 9

Geology Dept.

TN

870

R24p

1922

v.3

cop.2

