

10

90697
Smith
30

THE PHILIPPINE JOURNAL OF SCIENCE

EDITED BY

PAUL C. FREER, M. D., PH. D.

WITH THE COÖPERATION OF

DEAN C. WORCESTER, A. B.; ROBERT BENNETT BEAN, M. D.
MERTON L. MILLER, PH. D.; CHARLES S. BANKS, M. S.
ALVIN SEALE, A. B.; LAWRENCE E. GRIFFIN, PH. D.
RICHARD C. MCGREGOR, A. B.; NELLIE LOUISE COOK, B. L., M. A.

PUBLISHED BY

THE BUREAU OF SCIENCE

OF THE

GOVERNMENT OF THE PHILIPPINE ISLANDS

D. ETHNOLOGY, ANTHROPOLOGY, AND GENERAL
BIOLOGY

VOLUME V

1910

WITH 45 PLATES AND 25 TEXT FIGURES



MANILA
BUREAU OF PRINTING
1910

THE STATE OF

NEW YORK

IN SENATE,
January 1, 1901.

CONTENTS.

No. 1, June, 1910.

	Page.
I. Bean, Robert Bennett, assisted by Planta, Federico S. III. Filipino Types: Racial Anatomy in Taytay. (B) The Women	1
Plates I to VII; text figure 1.	
II. Bean, Robert Bennett. Paleolithic Man in the Philippines. Homo Philippinensis	27
Plate I.	
III. Banks, Charles S. Rhynchota Palawanica, Part II: Homoptera	33
Plate III.	
IV. Distant, W. L. Rhynchota Philippinensia, Part I	57
Plate I.	
V. Viehmeyer, H. On the Myrmecophily of Caterpillars of Catochrysops Cnejus Fabr	69
VI. Viehmeyer, H. A Myrmecophilous Lycænid Chrysalis from the Philippines	73
Text figures 1 to 4.	
VII. Banks, Charles S. The Polyscopic Cell.....	79
Plates I and II.	
VIII. Banks, Charles S. An Interesting Occurrence with Sticky Grass: Eragrostis viscosa Trin	85
IX. Griffin, Lawrence E. A Method of Using Magnesium Sulphate for the Anæsthetization of Marine Animals	86

No. 2, July, 1910.

I. Seale, Alvin. The Fishery Resources of the Philippine Islands. Part III. Pearls and Pearl Fisheries	87
Plates I to VI; text figures 1 to 5.	
II. McGregor, Richard C. Birds Collected in the Island of Polillo, Philippines	103
III. Seale, Alvin. Descriptions of Four New Species of Fishes from Bantayan Island, Philippine Archipelago	115
Plates I and II.	
IV. Forel, A. Fourmis des Philippines	121
V. Banks, Charles S. A New Accessory for Dissection Work	131
Plate I.	
VI. McGregor, Richard C. Birds from Pauai and Mount Pulog, Sub-province of Benguet, Luzon	135
VII. Weise, J. Verzeichniss von Coleopteren aus den Philippinen, nebst zwei neuen Arten aus Niederländisch Ostindien	139

No. 3, August, 1910.

I. Griffin, Lawrence E. The Pearl Fishery of Bantayan.....	149
II. Seale, Alvin. The Successful Transference of Black Bass into the Philippine Islands, with Notes on the Transportation of Live Fish Long Distances	153
Plate I; text figures 1 and 2.	
III. Schultze, W. Contributions to the Lepidopterous Fauna of the Phil- ippines	161
Plate I.	
IV. Moser, J. Neue Coleoptera Lamellicornia von den Philippinen.....	183
V. Bean, Robert Bennett. Filipino Ears, II: Ears from Malecon Morgue	191
Plates I to III.	
VI. McGregor, Richard C. Additional Notes on Birds from Northern Mindanao, Philippine Islands	197
VII. McGregor, Richard C. Note on the Migration of the Tie-Wee Buz- zard in the Philippine Islands	199
Plate I.	
VIII. McGregor, Richard C. Philippine Ornithological Literature, III.....	203

No. 4, October, 1910.

I. Griffin, Lawrence E. A List of Snakes from the Island of Polillo, P. I., with Descriptions of a New Genus and Two New Species.....	211
Plate I.	
II. McGregor, Richard C. Birds from the Coast of Northern Luzon and from the Islands of Sabtan and Dalupiri	219
III. Weise, J. Ueber Chrysoliden und Coccinelliden der Philippinen....	223
IV. Ohaus, Fr. Die Ruteliden der Philippinischen Inseln	233
V. Seale, Alvin. Fishes of Borneo, with Descriptions of Four New Species	263
Plates I to IV.	

No. 5, November, 1910.

I. Griffin, Lawrence E. Euplotes Worcesteri sp. nov.: I. Structure.....	291
Plates I to III; text figures 1 to 13.	
II. Review	313

No. 6, December, 1910.

I. Griffin, Lawrence E. Euplotes Worcesteri sp. nov.: II. Division.....	315
Plates IV to VIII.	
II. Review	337



VOL. V JUNE, 1910 No. 1

THE PHILIPPINE JOURNAL OF SCIENCE

EDITED BY
PAUL C. FREER, M. D., PH. D.

WITH THE COÖPERATION OF

DEAN C. WORCESTER, A. B.; ROBERT BENNETT BEAN, M. D.
MERTON L. MILLER, PH. D.; CHARLES S. BANKS, M. S.
ALVIN SEALE, A. B.; LAWRENCE E. GRIFFIN, PH. D.
RICHARD C. MCGREGOR, A. B.; NELLIE LOUISE COOK, B. L., M. A.

PUBLISHED BY

THE BUREAU OF SCIENCE

OF THE

GOVERNMENT OF THE PHILIPPINE ISLANDS

D. ETHNOLOGY, ANTHROPOLOGY, AND GENERAL
BIOLOGY

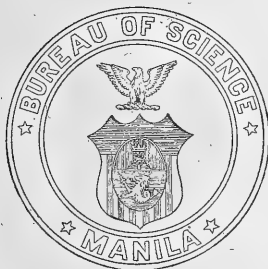

MANILA
BUREAU OF PRINTING
1910



Order No. 406.

THE HISTORY OF SULU.

By NAJEEB M. SALEEBY.

274 pages.

A complete history of the Moro People in Sulu, with maps and many translations from the original documents.

Price \$0.75 United States currency.

Order No. 405.

STUDIES IN MORO HISTORY, LAW, AND RELIGION.

By NAJEEB M. SALEEBY.

107 pages. 16 illustrations. 5 diagrams.

A treatise on the history and customs of the Moro people.

Price \$0.25 United States currency, paper; \$0.75 United States currency, half morocco.

Order No. 410.

MINDANAO.

THE SUBANUNS OF SINDANGAN BAY.

By EMERSON B. CHRISTIE.

This, together with the History of Sulu and the Studies in Moro History, Law and Religion, is one of an authentic and valuable set of works on the origin, history and customs of these tribes, who are among the most interesting people in the world.

Price \$1.25 United States currency.

Any of the above announced publications may be ordered from the Business Manager, Philippine Journal of Science, Manila, P. I., or from any of the agents listed on the cover of this Journal. Please give order number.

THE PHILIPPINE JOURNAL OF SCIENCE

D. ETHNOLOGY, ANTHROPOLOGY, AND
GENERAL BIOLOGY

VOL. V

JUNE, 1910

No. 1

III. FILIPINO TYPES: RACIAL ANATOMY IN TAYTAY.

B. THE WOMEN.

By ROBERT BENNETT BEAN, assisted by FEDERICO S. PLANTA.

(From the Anatomical Laboratory, Philippine Medical School, Manila, P. I.)

This is the third in a series of studies of Filipino types, the other two¹ of which and the first part² of the present study, "A. The men," have appeared in a previous issue of the JOURNAL.

Only 63 women were measured at Taytay and the data obtained may be consulted by referring to the table of "Actual measurements," page 17. The measurements were made at the same time and in the same manner as those of the men of Taytay, Mr. Planta doing the calculation and Doctor Bean writing the paper and making the deductions.

Casual observations lead to the conclusion that the women of Taytay are more Primitive than the men, and this may be corroborated or disproved by the present study.

THE BODY PARTS.

The comparison of the men and women of Taytay with the women of northeastern Siberia measured by Frau Jochelson Brodsky³ will constitute a feature of the present work. The comparisons will be made by using single measurements, taking the stature first.

¹ *This Journal*, Sec. A (1909), 4, 263, 297.

² *Ibid.*, 359.

³ Zur Topographie des weiblichen Körpers Nordostsibirischer Völker. *Arch. f. Anthrop.* Neue Folge (1906), 5, 158.

Stature.

Group.	Number of individuals.	Maximum.	Mean.	Minimum.
Taytay men -----	183	171	159	145.7
Taytay women -----	63	162.4	147.8	136.8
Siberian women -----	305	163	{ 146.5 to 149.1 }	137

The women of Taytay are below medium stature, accepting Topinard's classification, and they are relatively smaller than the men. The Siberian women are almost identical in stature, even to the maximum and minimum, because the extremes of 63 Taytayans are practically the same as those of 305 Siberians.

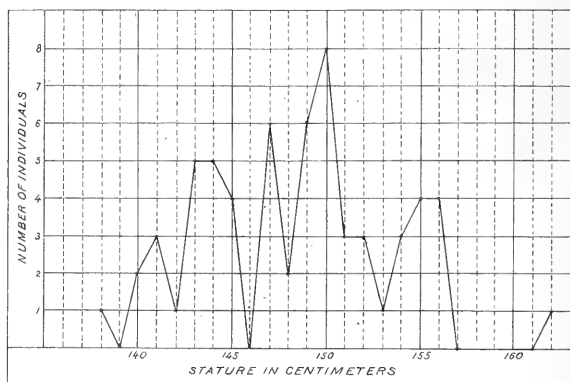

FIG. 1.

The curve of stature for the woman of Taytay is more irregular than that of any group of the Siberian women, indicating greater homogeneity for the latter, and a more complex composition for the Taytayans.

The stature is furthermore treated in groups by types as in former studies. The selection of types has been accomplished by the method adopted for previous groups of Filipinos, using the median stature of 153 centimeters for the women instead of 163 centimeters, which was used as the median for the men. In this way the following table is produced:

The stature of the types—women of Taytay.

Types.	Number of individuals.	Maximum.	Mean.	Minimum.
Primitive.....	2	142.1	141.2	140.3
Iberian.....	12	155.8	151.2	144
Australoid.....	7	149.5	144.4	136.8
Modified Primitive.....	2	149.3	149.2	149
Alpine.....	2	150.2	147.5	144.7
B. B. B.....	1		155.3	
Adriatic.....	1		155.8	
Blend.....	36	162.4	147.8	138

It is seen that the stature of all the types except the B. B. B. and Adriatic is below medium, and that of the Primitive is small. The Iberian is below medium height, whereas the Iberian of Europe is above medium height, and the student Iberian is taller than the European. This indicates that the women of Taytay are primitive in stature, even when the type is Iberian. The Australoid is intermediate in stature between the Primitive and the Iberian, although nearer the former than the latter.

The Blend has a greater extent of variability as indicated by the maximum and minimum, and the Primitive and Modified Primitive have the least variation of all. The Iberian has less distance between the extremes than the Australoid, although almost twice as numerous. The Iberian and Primitive are therefore to be considered more homogeneous than the other types and the Blend and Australoid not so homogeneous.

Sitting height.

Group.	Number of individuals.	Maximum.	Mean.	Minimum.
Taytay women.....	63	82.90	78.54	71.30
Taytay men.....	183	91.70	83.99	74.30
Jakuten (women).....	64	83.70	78.12	72.50

The sitting height is compared first by the general average, and afterwards by types. The sitting height of the women is less than that of the men, and the variation of the two groups as indicated by the extremes is about in proportion to the number of individuals in each group. The sitting height of the women is greater than that of the men relatively to stature, and that of the Taytayan women is relatively greater than that of the Siberian.

The mean sitting height of the Taytay women is nearer the maximum than the minimum, which indicates that a larger number of the women have a sitting height near the maximum than near the minimum; and as the greater sitting height is supposed to represent the Primitive type, this is an indication that a greater number of the Taytay women partake of the Primitive type than of the Iberian or the other types. The mean sitting height of the Siberian women, on the other hand, is almost exactly intermediate between the extremes, indicating an even distribution of sitting heights about the mean, therefore more homogeneity.

The relatively greater length of body in the women of Taytay seems to be due to the predominance of the Primitive type among the Blends as indicated in the following tables:

Relative sitting height by type.

MEN OF TAYTAY.

Type.	Num-ber.	Stature.	Relative sitting height.
Primitive.....	3	150.2	53.6
Modified Primitive.....	6	156.3	53.2
Australoid.....	32	157.7	53.7
Blend.....	92	158.8	52.9
Alpine.....	10	159.8	52.8
Iberian.....	17	160.8	52.8
B. B. B.....	2	165.4	53.1
Cro-Magnon.....	11	167.8	52.6

WOMEN OF TAYTAY.

Type.	Num-ber.	Stature.	Relative sitting height.
Primitive.....	2	141.20	52.66
Australoid.....	7	144.40	52.59
Alpine.....	2	147.45	51.73
Blend.....	36	147.78	53.15
Modified primitive.....	2	149.15	53.30
Iberian.....	12	151.20	52.58
B. B. B.....	1	155.30	52.93
Adriatic.....	1	155.80	52.18

The sitting height in general is relatively less for the tall than for the small individuals.

Taken by type, the Blend, with less stature than some other types, has relatively greater sitting height, and this difference is greater in the females than in the males. The Primitive type, also with less stature than any other type, has a greater relative sitting height among the males than any other type except the Australoid, and among the females a greater relative sitting height than any other except the modified Primitive, Blend, and B. B. B. This indicates that the Australoid males and the modified Primitive, Blend, and B. B. B. females are influenced in relative sitting height by the Primitive, provided, of course, we accept the conclusions of the author, that the Primitive has a relatively long body and short legs. The Australoid type resembles the Primitive among females, and the Iberian among males, in both stature and relative sitting height, which may lead us to think that the primary inhabitants were Primitive and the secondary Iberian, provided again we accept the conclusions of the author that the Australoid is a product of the Iberian and Primitive with mosaic characteristics, especially the disharmonic

physiognomy, and provided we also accept Pearson's law that males inherit more from the father, and females more from the mother.

Lower extremity.

Group.	Number.	Maximum.	Mean.	Minimum.	Relative to stature.	Stature.
Taytay men	188	95	83.08	72.8	52.10	159.47
Taytay women	63	84	76.80	69.6	51.96	147.8
Jakuten women	65	84	74.87	62.7	50.47	148.34

Turning now to the length of the lower extremity as expressed by the trochanter height, we find that the females are less than the males both in absolute measurements and in relation to stature. The latter is slight, however, and the males and females are practically identical. The Jakuten of Siberia have less trochanter height, relatively and absolutely, than the woman of Taytay. They have also less than the other Siberian women measured by the same author, but all the Siberian women are practically the same in these dimensions. The indication is that the women of Siberia have more Primitive elements than either the men or the women of Taytay, as represented by absolute and relative trochanter height, and the women of Taytay have more Primitive elements than the men, although this is a negligible fact. It may be of interest to note in this connection that the height of the pubis is, relatively to stature, 51.3 for the Taytay women, 49.4 for the Siberian women, and 52 for the Russian women measured by Teumin.

The trochanter height.

MEN OF TAYTAY.

Type.	Number.	Stature.	Relative trochanter height.
Primitive	3	150.2	50.8
Modified Primitive	6	156.3	51.2
Australoid	32	157.7	51.7
Blend	88	158.8	51.9
Iberian	17	160.8	52.4
Cro-Magnon	11	167.8	53.1

WOMEN OF TAYTAY.

Type.	Number.	Stature.	Relative trochanter height.
Primitive	2	141.2	51.6
Australoid	7	144.4	51.8
Alpine	2	147.4	52.8
Blend	36	147.8	51.5
Modified Primitive	2	149.2	51.6
Iberian	12	151.2	52.6
B. B. B	1	155.3	52.8
Adriatic	1	155.8	53.9

When the trochanter height of the types of the men of Taytay is contrasted with that of the women, it is noted that the relative trochanter height increases with increase of stature, but the Primitive, Modified Primitive, Australoid, and Blend of the women have a relative height about the same, with varying stature, and the Alpine, Iberian, B. B. B., and Adriatic also have a relative height about the same, but different from that of the other four types. The stature varies also, but is higher in the last four than in the first four, except the Alpine, which is less than the Modified Primitive and Blend.

Pfützner⁴ has demonstrated that the relative body length decreases with increase of stature in both male and female from a stature of 41 centimeters to that of 180, and the relative length of the extremities (arm and leg) increases with each increment of stature. This is corroborated by my findings, and it would appear that the greater relative leg length is no more than an additional increment of stature, or that stature and leg length are highly correlated. This is no doubt true, and as demonstrated by Martin and others the upper leg length and stature are more highly correlated than are other parts with the stature. However, the cause of the correlation is as yet, undefined. If it is a matter of stature, then additional stature causes additional and relatively longer limbs. If it is a matter of limb development, then the long extremities cause greater height, but not so great in proportion to the length of the extremities. If it is a matter of the interplay of factors in development, then the undeveloped have small stature and relatively less limb length and the fully developed, or overdeveloped, have tall stature and relatively greater limb length. This is probably the true cause, and not only is it true in the development of the individual, but also in the development of the species. The Primitive and its related types are early species of man, and the form is retained more largely in women at present, with small stature, relatively long body and relatively short extremities; whereas the Iberian and its related types are more recent species of men and have the form retained more largely in men, with tall stature, relatively short body and relatively long extremities.

UPPER EXTREMITY.

The length of the upper extremity as represented by the distance from the acromion process to the finger tip may be considered in this connection.

Group.	Relative length of the upper extremity.	Number of individuals.
Men of Taytay -----	45.8	180
Women of Taytay -----	45.0	63
Women of Siberia -----	44.5	113

⁴Pfützner, W. Social-Anthropologische Studien. IV. Die Proportionen des erwachsenen Menschen. *Ztschr. f. Morphol. u. Anthropol.* (1903), 5, 201-314.

Men have relatively longer arms than women, and the Taytayans have relatively longer arms than the Siberians. The first statement is confirmed by Frau Jockelson-Brodsky, who assembles the records of measurements made by 33 different investigators of related Siberian peoples, and in only one group does the relative arm length of the women exceed that of the men, and in only five groups does it exceed 54.0, in the Lapps, the Ainos, the Jakuten, the Kirgisen and Sojotimmen, and in each group the relative length is less than that of the men of Taytay. There is so little difference, however, that no conclusions may be drawn with safety. There is apparent correlation of stature and arm length, as there is of stature and leg length.

TROCHANTER HEIGHT AND PUBIS HEIGHT.

The difference between the height of the pubis and the trochanter is greater in the men of Taytay (difference 1.3 centimeters) than in the women (difference 1.0 centimeter), whereas the two points in the Siberian women are practically identical. There would seem to be a sexual difference, a higher trochanter in men, or a lower in women, or a higher pubis in women and a lower in men, although a greater amount of material should be utilized before this can be definitely decided.

The omphalic index.

Group.	Num-ber.	Maxi-mum.	Mean.	Mini-mum.	Author.
Men of Taytay	180	60.26	42.35	20.36	Bean.
Women of Taytay	63	73.20	48.20	32.30	Do.
Jakuten (women)	64	42	42	42	Jockelson Brodsky.
Russian women and Russian Jew- esses			33		Teumin.

The navel of the men is lower than that of the women, which has been demonstrated already for the Igorots and Morgue subjects; the navel of the women of Siberia is at about the same relative position as that of the men of Taytay. Siberian men are not to be compared with the Siberian women, but no doubt if such a comparison could be made the men would be found to have lower navels than the women. The Jewish and Russian women have lower navels than any other group under consideration. This is of interest when the omphalic index is considered in relation to type as follows:

The omphalic index.

MEN OF TAYTAY.

Type.	Num-ber.	Omphalic Index.		
		Maxi-mum.	Mean.	Minimum.
Primitive	3	56.5	44.1	37.0
Australoid	32	53.9	41.4	26.2
Iberian	15	52.8	42.9	33.5
Cro-Magnon	11	51.6	42.9	38.6
Alpine	10	52.2	42.6	36.3
Blend	88	57.6	42.2	20.4
Modified Primitive	6	46.2	43.1	35.2

The omphalic index—Continued.

WOMEN OF TAYTAY.

Type.	Number.	Omphalic index.		
		Maximum.	Mean.	Minimum.
Primitive.....	2	47.7	47.6	47.5
Australoid.....	7	68.6	48.4	36.8
Iberian.....	12	54.6	46.4	38.4
Alpine.....	2	45.4	39.2	33
Adriatic.....	1		38.8	
B. B. B.....	1		37.6	
Blend.....	36	73.2	49.9	32.3
Modified Primitive.....	2	47.8	46.2	44.6

Among the men the Primitive and Modified Primitive types have a higher omphalic index than the others and the Australoid has the lowest of all. Among the women the Australoid, the Blend and Primitive types have the highest indices, and the Alpine, Adriatic, and B. B. B. have the lowest; but only four individuals of the latter types were observed. The significant facts are that the Iberian and its related types have a lower index than the Primitive and its related types in both men and women, with slight exceptions. The Blend among the men has a low (42.2) and the Blend among the women a high index (49.9) which indicates that the female Blend is more largely Primitive and the male Blend more largely Iberian in omphalic index. It is to be supposed from the above that the women of Europe, particularly the Russian and Jewish women, are largely Iberian and the Siberian women are largely Primitive.

The omphalic index of the Igorot women and of the women measured in Malecon morgue is greater than that of the men of these groups, and the omphalic index of the Igorot boys is also greater than that of the men, all of which indicates that women are more Primitive than men in this respect.

RELATIVE UPPER-ARM LENGTH.

In the previous study of the men of Taytay it was noted that the relative upper-arm length, the brachial index and the crural index were factors that differentiated the Taytayan from other groups such as the Soudanese Negroes, the European, etc.; therefore it may be well to examine these factors in the women of Taytay.

The relative upper-arm length of the men of Taytay is greater than that of any other people except the Sikh, Chinese, and European, and since this factor is the same for the women of Taytay it may be dismissed. There is also little difference between the types in this factor, so that its varieties have relatively shorter upper arms than the Iberian and its varieties, following in this the relative length of the upper leg. This may be significant as a differential factor of the types, or only in-

cidental to stature, the types with small stature having relatively short upper arms and legs, and the types with medium or tall stature having relatively long upper arms and legs. The brachial and crural indices may throw some light on these conditions.

BRACHIAL INDEX (RADIO-HUMERAL).

The brachial index of the women of Taytay is 70.1, a little less than that of the men. It is also less than that of the Russian women measured by Teumin, 72.4, the Siberian women measured by Jochelson-Brodsky, 75.0, the Aino women of Koganei, 79.4, and the Japanese of Bälz, 80.5 to 89. The same index is 75.6 for the Igorot women. When this is examined for the types, the results are somewhat discordant; although the Primitive and related forms have a higher index than the Iberian they are practically the same, and the low index of the Australoid may be attributed to Iberian influence. The male Blend, which has heretofore seemed to have more Iberian or fewer Primitive elements than the female Blend, in this instance seems to have more Primitive elements or fewer Iberian elements. However, the Primitive, Modified Primitive, and Blend have higher indices than the Iberian, Cro-Magnon, and Australoid, which indicates that the Primitive brachial index is higher than the Iberian.

The brachial index.

Type.	Number.	Men.	Number.	Women.
Primitive.....	3	73.7	2	74.4
Australoid.....	33	70.4	6	66.2
Iberian.....	15	70.8	11	68.8
Cro-Magnon.....	11	72.5		
Alpine.....	10	68.9	2	72.8
Blend.....	87	79.8	36	72.2
Modified Primitive.....			2	70.2

If this applies to the Russians, Siberians, and Japanese, then, without doubt, the Primitive elements increase as the Orient is approached through those three peoples, certainly among the women. The Taytay women in brachial index appear to have more Iberian elements and fewer Primitive than any of the three.

Hamy⁵ gives the brachial index of infants and children as 88.88 for those aged 2 months, and 72.30 for those aged 5 to 13.5 years, which would indicate that the Primitive is more infantile than the Iberian, because the brachial index of the Primitive is higher than that of the Iberian.

⁵ Hamy, E. T. Recherches sur les proportions du bras et de l'avant bras aux differents ages de la vie. *Bull. Soc. Anthropol. Paris, deuxieme serie* (1872), 7, 495-513.

The brachial index of the Taytay women exhibits marked individual variation by reason of the great shortening of the humerus in not a few individuals. Three women were seen in Taytay, one in the neighboring barrio of Rosario, and two in the town of Pasig, about 1 kilometer distant, who had upper arms not more than 10 or 12 centimeters in length, and forearms of the usual length. Unfortunately none of these women could be measured, therefore no record may be made of their brachial index. It is probably a pathologic condition due to defective nutrition or disease, and not a type, although congenital or hereditary predisposing causes can not be excluded.

THE CRURAL INDEX (TIBIO-FEMORAL).

The index of the women of Taytay is 5 less than that of the men (95.1 and 90.1), but in no way can this be compared with the index of the women of Siberia, because of differences in measurement and computation. Considered from the standpoint of type, however, the following differences are determined:

The crural index.

Type.	Num-ber.	Men.	Num-ber.	Women.
Primitive.....	3	92.7	2	92.7
Australoid.....	33	97.3	7	94.5
Iberian.....	15	94.2	12	88.6
Cro-Magnon.....	11	93.4		
Alpine.....	10	96.0	2	88.3
Blend.....	87	95.1	35	91.1
Modified Primitive.....	7	97.9	2	89.7

The evidence from this table is that the Primitive has a smaller index than the other types except the Iberian and Alpine women, but so few as five individuals do not constitute a fair number for an average. The Modified Primitive of the men has the highest index of all, but the index of the women is low; since here again only two individuals were measured, this may be disregarded. The crural index of the Primitive Morgue subjects was calculated to be more than 100, although only 7 men and 3 women were measured. It would be advisable to measure a greater number of the Primitive type before the crural index can be determined absolutely.

There can be no doubt but that the Australoid type has a high crural index, because enough individuals have been measured to indicate this, and all the measurements are corroborative. This would make the Australoid like the Negro and Negrito. The Iberian, on the other hand, has a lower index, the Cro-Magnon and Alpine as well. The Blend, too, has a low index which denotes greater Iberian and Primitive(?) influence than Australoid.

The crural index of the women in each type except the Primitive is

less than that of the men, which means that the women have relatively shorter lower legs than the men. They are thus more Primitive, provided the Primitive is found to have a relatively low index.

To summarize the measurements of the body parts:

The stature of the women of Taytay is small, identical with that of the Siberian women, although more variable, and relatively less than the stature of the men of Taytay. The sitting height of the women of Taytay is practically the same absolutely and in relation to stature as that of the Siberian women, although the relative sitting height is greater than that of the Siberian women or of the men of Taytay.

The leg length of the women of Taytay is absolutely and relatively greater than that of the Siberian women and less than that of the men of Taytay. Leg length is highly correlated with stature, and this may be due either to ontogeny or phylogeny, or to both.

The arm length is similar to the leg length in its various relationships.

The pubis of woman is probably lower than that of man.

The omphalic index of woman is higher than that of man, and the omphalic index of the Siberian women is intermediate between that of the women of Taytay and the women of Europe, and it is exactly the same as that of the men of Taytay. The women of Europe have a very low index and the women of Taytay have a very high one.

The brachial index of the women of Taytay is a little less than that of the men, which is less than that of the Russian women.

The crural index increases in women as follows:

Taytayan	70.1
European	72.4
Siberian	75.0
Aino	79.4
Japanese	80.5-89.0

The crural index of the women is less than that of the men.

From the standpoint of type the greatest differences appear between the Primitive and the Iberian, and in practically all the measurements the women are more Primitive than the men, and the men are more Iberian than the women. The Australoid type is intermediate between the Iberian and Primitive, except in brachial index, in which it is almost exactly the same as the Iberian and the crural index, in which it is like neither, but resembles the Negrito.

THE HEAD AND FACE.

The body parts having been discussed, attention may now be devoted to the head and face. A comparison of the most important indices will be made.

Cephalic index.

Group.	Num-ber.	Maxi-mum.	Mean.	Mini-mum.
Men of Taytay -----	182	94.3	81.8	72.0
Women of Taytay -----	63	95.6	82.9	73.8
Jakuten (women) -----	57	90.0	83.3	74.0

The cephalic index is greater for the women than for the men, and the Siberian women (Jakuten) have the same index as the women of Taytay, although this group of Siberian women, the Jakuten, has a higher cephalic index than the other groups of Siberians given by Frau Jochelson-Brodsky. In this, as in the stature and other measurements, the Jakuten and the women of Taytay are alike.

The cephalic index of the types is distinctive because it is used as a differential factor in conjunction with the stature and nasal index in the segregation of types; therefore it may be presented without comment.

The cephalic index.

Type.	Num-ber.	Index.	Num-ber.	Index.
Primitive.....	3	88.5	2	86.3
Iberian.....	15	76.2	12	77.9
Australoid.....	35	78.0	7	78.3
Alpine.....	11	87.7	2	92.9
B. B. B.....	2	82.8	1	85.5
Cro-Magnon.....	12	78.3		
Blend.....	91	83.3	36	84.2

Nasal index.

Group.	Num-ber.	Maxi-mum.	Mean.	Minimum.
Men of Taytay.....	182	110.0	85.2	54.9
Women of Taytay.....	63	114.7	86.0	68.1
Jakuten (women).....	30	78.0	64.6	55.0

The women of Taytay have wider noses than the men, and a great deal wider than those of the Siberian women (Jakuten), which may be due to the fact that Frau Jochelson-Brodsky used the nasion and I used the line of greatest depression of the nose bridge as the point from which to measure the nose length. A difference of 8 to 10 points less is obtained by using the nasion instead of the line of greatest depression, and this may account for some of the difference between the two groups of women; but after all deductions are made, there remains a considerable distinction, and the nose of the women of Taytay is wider than that of the Siberians. The nasal index by type is presented without comment for the same reason that the cephalic index was so presented.

The nasal index.

Type.	Men of Taytay.		Women of Taytay.	
	Num-ber.	Index.	Num-ber.	Index.
Primitive.....	3	89.1	2	107.4
Iberian.....	15	78.5	12	77.4
Australoid.....	35	93.3	7	97.4
Alpine.....	11	70.1	2	82.0
B. B. B.....	2	67.6	1	66.0
Cro-Magnon.....	12	93.4		
Blend.....	91	83.8	36	85.2

The face index (morphologic).

Group.	Num-ber.	Maxi-mum.	Mean.	Mini-mum.
Men of Taytay	178	98.3	81.3	66.1
Women of Taytay	61	90.4	79.1	66.9
Jakuten (women)	38	95.0	84.0	76.0

The face of the women of Taytay is relatively broader than that of the men, and both are broader than the face of the Siberian women. It is to be noted in all the head and face indices that there is a greater range of variation, judging from the extremes, in the women of Taytay than in the Siberian women.

In the consideration of face index and type a combined face index is utilized because this is a better differentiation than either the morphologic or physiologic face index alone. The combined face index is obtained by dividing the morphologic by the physiognomic (combined face index = $\frac{\text{morphologic face index}}{\text{physiognomic face index}}$). The following table is the result:

The combined face index—women of Taytay.

Type.	Num-ber.	Maxi-mum.	Mean.	Minimum.
Primitive	2	86.3	83.3	80.3
Iberian	12	143.9	117.8	99.8
Australoid	7	127.8	113.8	95.2
Alpine	2	117.8	114.3	110.8
B. B. B.	1		88.0	
Modified Primitive	2	96.4	91.7	87.1
Blends	34	139.1	108.8	87.8
Adriatic	1		113.7	

A high combined face index means a relatively long and narrow face, whereas a low combined one means a relatively short and broad face.

The Primitive and the Iberian are more distantly separated in this particular than any of the other types, and the Blends are nearer the Iberian than the Primitive. The Australoid and the Alpine also resemble the Iberian in this respect. The Modified Primitive is more like the Primitive.

To summarize the head, nose and face:

The cephalic index, nasal index, morphologic face index, and combined face index demonstrate that the women of Taytay have relatively broader heads, faces and noses than the men of Taytay, and the latter have the same characters relatively broader than the Siberian women, except that the cephalic index of the men of Taytay is slightly less than that of the others. The broad head, face and nose characterize the Primitive type, which would indicate that the women of Taytay are more Primitive than the men, or than the Siberian women.

THE EAR FORM.

The ears of the women of Taytay are not definite in type, but more mixed than those of the men. Unlike the other physical characteristics which are so largely Primitive in nature, the ears of the women are more largely Iberian, 52 of the 63 having Iberian characteristics pure or mixed, whereas only 8 have Primitive. There are also 14 that partake of the B. B. B. type, entirely or in part. No other forms appear to any considerable extent, although 16 are noted as mixed, which means that the type is not pure. The inference is that the ears of the women of Taytay are impure Iberian, partaking therefore of the Australoid, with Primitive markings.

When the "Type of individuals" in the fifth column from the right side of Table II, page 20, is corrected by the use of the ear type as a factor, and removing from the Blend those individuals resembling the Iberian or the Primitive, the following changes occur, as represented by the "Species of individuals" in the first column of the same table: Eight Blends become Iberian, six Blends become Primitive, and one Blend becomes an Australoid by its similarity to the latter type. Twenty-one Blends remain Blends. It is to be noted that the Blends that become Iberian are more like the Primitive than are those becoming Primitive like the Iberian; and as the Blends which remain are also more like Primitive than the Iberian, this is additional evidence that the Blends partake more of the former than of the latter in characteristics.

In this connection refer to Plate I where the Iberian (D) on the left may be compared and contrasted with the two Primitive (Blends). This may also be done more in detail by reference to Plates II, III, and IV, where both front and profile views may be seen. There can be no mistaking the Iberian characteristics of the woman in Plate IV. The long, narrow head and face, the long nose, the long ears with pendant lobule, everted concha, and helix that is rolled out below, are morphognomic (a new word similar to pathognomic and having the same meaning in relation to pathological conditions). Likewise, the two young women are unmistakably Modified Primitive in type, with shorter, broader heads, faces, noses, and ears, the last with somewhat depressed concha and lower helix turned forward. The same is true also of the Primitive (Blend) of Plate VI.

There are only two other plates, which will be described at this time to complete their consideration.

The modified B. B. B. of Plate V is a fair representative of this type as ordinarily seem among Filipinos, although it is by no means the pure B. B. B. as found among Europeans. However, the head and face are somewhat oblong and the ear is faintly so. The photograph does not show the ear to advantage; it is somewhat more oblong in shape

than it appears. Plate I shows the figure on the right representing a woman who is square-set and solidly built, in contrast to the slender Iberian at the opposite end of the plate and the rounded lines of the other figures. There can be no doubt that these three types, the Iberian, the Primitive, and the B. B. B., exist among the women at Taytay, and the Australoid is also found, although no Australoid or Primitive of pure type could be photographed.

The dwarf of Plate VII is of a Modified Primitive type but by no means a pure Primitive. She is about 125 centimeters in height, very shy, childlike and simple-minded, and could not be prevailed upon to submit to any sort of measurements.

Disease and species.

Group.	Tubercu- losis.	Tumors.	Other af- fections.	Number.
Iberian	3	4	3	20
Primitive	0	0	2	10
Blend	1	3	2	21
Australoid	1	0	0	8

The number of diseased persons is so small that a fair comparison is impossible, but the data corroborate previous findings; therefore they may be taken as substantiating former deductions. Fifty per cent of the Iberians examined were diseased, whereas only 20 per cent of the Primitive and about 30 per cent of the Blend were diseased. Fifteen per cent of the Iberians had tuberculosis, whereas none of the Primitives were so affected, and only one Blend and one Australoid had the disease. Two of the Iberians suffered with beriberi, which indicates that the Iberian is not immune to beriberi.

It is obvious from the above that the Iberian women of Taytay are more diseased than the Primitive, and they seem to be especially liable to tuberculosis.

In conclusion it may be said that the morphology of the women of Taytay is more Primitive than that of the men and resembles the women of Siberia. The types of ears and the physical types are as definite among the women as among the men, and are thereby more firmly established as entities. The Blend is largely Primitive in character and the Australoid is between the Iberian and the Primitive.

TABLE I.—Actual measurements, in

Serial No.	Clinical No.	Body.													Head.				
		Age.	Stature.	Sitting height.	Pubic height.	Umbilical height.	Sternal height.	Chin height.	Ear height.	Ankle height.	Knee height.	Trochanter height.	Finger-tip height.	Wrist height.	Elbow height.	Acromion height.	Maximum.		
																	Length.	Breadth.	Height.
1	428	45	140.5	76.9	69.5	82.6	113.4	118.3	127.3	5.3	40.8	69.6	52.6	68.0	85.0	114.0	19.1	14.1	12.6
2	407	18	150.5	77.3	76.3	94.0	122.0	128.5	138.0	6.1	43.5	79.0	54.0	71.0	93.2	121.0	16.6	14.8	12.1
3	393	40	147.0	81.8	73.5	89.8	118.7	123.6	133.6	5.1	36.5	75.0	53.0	70.7	89.7	120.0	17.5	15.2	12.0
4	429	30	150.8	80.1	75.4	92.5	120.6	127.2	137.3	5.0	38.2	77.8	52.3	68.0	90.2	123.0	17.6	15.3	12.9
5	427	40	145.1	77.3	75.0	92.5	119.0	123.4	133.0	5.3	38.6	75.2	54.2	70.6	91.0	121.4	17.9	13.8	12.0
6	468	45	149.4	78.1	77.8	91.0	120.5	128.0	137.4	5.6	41.3	78.2	58.0	74.8	94.4	124.6	18.2	14.3	11.6
7	445	27	141.4	75.7	74.7	85.2	116.0	122.0	130.4	6.1	36.5	73.0	53.4	69.4	88.0	116.4	17.2	14.5	11.6
8	443	37	143.0	78.7	70.5	84.0	114.8	119.8	130.7	5.5	36.0	71.2	53.8	70.0	89.0	116.5	18.1	14.9	12.3
9	444	20	142.1	75.5	73.0	86.4	114.6	121.4	130.5	4.9	38.2	74.0	49.5	65.8	86.7	115.2	16.3	14.2	-----
10	-----	49	142.7	77.5	70.6	84.5	113.4	119.4	130.0	4.8	38.7	72.3	50.6	67.0	84.8	115.3	17.2	14.5	11.7
11	460	50	146.6	78.7	77.7	90.5	117.2	124.8	134.2	5.4	38.2	76.5	54.5	70.8	91.5	119.7	17.7	14.6	11.0
12	-----	50	146.5	76.1	75.6	88.0	118.4	126.2	133.5	6.0	37.3	76.5	51.8	67.2	89.0	119.5	18.1	14.4	11.3
13	468	50	149.3	80.3	79.2	92.4	122.0	129.2	137.8	6.1	39.8	77.0	56.0	71.5	92.0	122.7	16.9	14.3	11.4
14	499	50	150.2	77.2	80.8	93.2	120.5	127.0	136.0	6.2	40.0	78.2	58.0	73.4	94.3	126.0	16.9	15.3	11.2
15	-----	45	149.2	82.5	74.5	92.0	119.2	126.3	135.5	6.0	38.5	75.0	57.0	72.2	93.5	121.5	17.1	15.0	12.0
16	262	25	149.0	78.7	75.0	91.3	121.2	128.3	137.2	5.8	39.3	77.0	57.2	72.8	94.4	123.6	15.8	15.1	11.6
17	498	31	150.3	80.3	72.0	92.8	121.2	128.7	136.2	5.9	42.5	74.0	56.8	70.8	93.8	124.0	18.0	14.3	12.3
18	-----	30	143.8	78.8	73.5	89.4	115.5	123.5	131.0	5.5	35.6	73.4	50.0	67.8	87.0	117.5	16.3	14.0	11.8
19	507	60	149.7	80.7	76.6	88.0	120.2	127.0	137.3	5.0	39.3	78.8	53.8	71.5	95.0	124.5	17.5	14.6	12.0
20	433	60	155.3	82.2	79.8	92.2	125.2	132.0	141.3	6.5	40.5	82.0	59.3	76.8	95.9	127.2	17.2	14.7	12.0
21	512	50	155.3	79.1	80.8	95.6	125.5	130.8	140.0	6.0	42.2	82.7	55.6	72.8	95.8	126.0	18.4	14.3	12.5
22	-----	20	155.8	81.3	82.8	95.5	128.2	133.6	144.2	5.8	40.0	84.0	58.0	74.3	95.6	129.3	17.7	15.4	12.2
23	506	36	149.5	81.1	74.8	88.0	118.7	127.2	135.7	5.0	38.5	76.5	50.5	66.8	87.3	121.8	17.6	14.1	12.4
24	213	80	156.0	81.5	80.4	91.6	126.2	132.5	142.0	6.2	40.2	81.1	54.8	71.4	94.5	126.5	18.5	14.9	12.3
25	524	24	154.0	-----	78.4	93.5	125.6	133.0	141.3	5.8	42.8	79.6	62.0	78.0	99.0	129.0	18.0	14.0	12.7
26	2	50	153.8	79.4	81.2	97.5	124.7	131.0	140.5	6.1	44.0	82.0	56.6	74.0	95.0	127.5	17.1	13.9	11.6
27	221	37	155.3	81.3	77.5	92.7	123.3	131.4	140.5	5.5	40.4	82.3	58.5	72.6	96.0	127.2	18.9	14.9	12.3
28	253	43	151.8	80.1	78.0	94.7	124.3	129.8	140.4	5.6	38.0	78.5	61.0	78.6	100.0	128.0	18.1	14.3	12.6
29	-----	22	150.3	79.2	75.8	90.5	121.0	127.0	137.0	6.2	38.4	78.7	53.2	70.4	92.3	123.0	18.2	14.1	12.5
30	572	34	144.1	75.5	75.6	87.2	116.8	123.0	132.0	5.8	42.4	77.4	54.4	70.2	89.6	118.0	18.3	14.4	11.5
31	578	30	143.7	79.5	70.2	84.2	116.5	123.4	131.3	5.3	35.4	70.7	50.8	66.8	86.8	117.8	16.8	14.0	12.0
32	645	39	144.0	78.9	71.4	87.5	117.0	122.5	132.6	4.7	36.7	71.3	53.4	69.7	88.8	116.4	18.7	14.7	12.0
33	677	50	162.4	81.2	79.2	90.5	123.7	131.0	140.5	5.7	39.5	78.7	55.4	72.2	93.0	123.5	16.6	14.9	12.3
34	652	23	155.6	81.3	82.4	94.0	125.5	133.2	141.5	6.3	39.5	79.8	56.0	73.0	94.4	126.7	17.8	14.8	12.6
35	664	50	146.8	79.7	71.0	87.5	118.0	124.7	134.2	5.8	37.7	72.3	53.5	69.0	90.0	120.5	16.8	14.7	12.4
36	699	50	148.3	77.9	73.8	87.8	117.0	123.0	133.5	6.4	39.0	78.0	55.0	72.0	90.5	119.7	17.9	14.5	13.0
37	70	45	151.3	80.3	78.6	93.0	121.5	127.3	137.8	5.5	40.0	80.0	55.0	72.4	93.0	123.0	18.8	14.3	12.2
38	690	60	145.4	79.7	72.6	81.6	115.8	123.7	133.0	4.9	37.0	73.5	53.4	69.2	88.7	-----	17.5	13.8	12.3
39	-----	48	144.7	75.3	75.0	85.3	116.5	124.0	133.3	5.5	39.3	77.6	47.0	64.3	83.2	118.0	16.8	16.0	12.5
40	698	50	149.3	79.8	75.5	88.5	118.0	129.5	137.3	5.8	40.5	77.8	55.0	71.5	94.0	123.2	18.0	14.1	11.8

centimeters—the women of Taytay.

Head.

Forehead width.	Bi-zygomatic diameter.	Bi-mastoid diameter.	Bi-goniac diameter.	Naso-buccal.	Naso-alveolar.	Nose-buss.	Nasion hair-line.	Chin-masson.	Nose width.	Nose length.	Mouth width.	Mouth length.	Ear length.	Ear length.	Ear cartilage.	Interocular distance.	Eye length.	Eye color.	Frontal circumference.	Parietal circumference.	Forehead circumference.	Occipital circumference.
10.3	13.0	12.6	10.6	6.7	5.6	2.1	8.0	10.2	4.5	4.2	1.1	4.8	3.0	6.4	4.6	3.1	3.10	7	29.5	36.4	26.0	31.0
10.0	13.6	12.6	10.6	6.3	6.1	2.2	7.6	9.6	3.6	4.0	1.5	4.3	3.6	6.0	4.9	3.3	2.95	2	29.8	33.8	26.8	26.0
10.6	13.6	11.6	10.6	6.8	6.0	2.8	7.0	10.0	4.0	4.8	1.3	4.8	3.6	5.9	4.8	3.7	3.10	2-3	29.1	36.7	27.2	28.0
10.6	13.5	12.1	10.6	6.8	6.4	2.5	7.0	10.5	3.8	4.2	2.0	4.4	3.7	6.0	4.4	3.4	3.15	3	33.0	37.2	26.6	27.8
9.8	12.7	11.6	10.0	6.7	5.8	2.4	8.2	10.4	4.3	4.2	1.3	4.6	3.4	6.0	4.8	3.1	3.00	4	28.0	34.2	25.0	29.0
10.6	13.0	12.1	10.0	6.9	6.0	2.2	6.9	11.0	3.9	4.5	1.5	4.4	3.7	6.5	5.0	3.4	3.15	4	29.9	34.7	27.6	28.0
10.7	12.9	12.0	9.8	6.4	6.2	2.2	7.4	10.0	3.6	4.2	1.2	4.1	2.9	5.8	4.8	3.4	2.95	3	28.8	32.6	26.7	28.0
10.2	13.0	12.0	10.2	7.4	7.0	2.5	8.4	11.7	3.6	4.8	2.1	4.0	3.2	6.3	4.7	3.1	2.90	3	31.9	37.0	28.0	28.4
10.3	13.0	-----	10.0	5.7	5.2	2.6	6.9	8.7	3.9	3.4	1.8	4.6	-----	-----	-----	3.4	2.95	-----	-----	-----	-----	-----
10.3	13.1	12.0	9.6	7.0	6.1	2.2	7.9	10.4	3.7	4.8	1.8	4.1	3.3	6.1	4.7	3.4	3.00	2	30.4	36.4	26.7	27.5
10.3	12.7	12.1	9.5	7.0	6.0	2.3	7.6	11.0	3.9	4.8	1.6	4.1	3.4	6.3	4.9	3.3	2.95	4	28.6	34.0	25.2	27.8
10.1	12.5	12.1	10.1	6.1	5.6	2.5	9.6	9.3	3.5	4.6	1.4	4.3	3.5	6.7	5.2	3.0	2.85	3	28.0	35.9	25.8	28.3
9.4	13.3	12.4	10.2	5.8	5.4	2.4	7.9	9.7	4.4	4.4	1.7	4.5	3.3	6.3	4.9	3.5	2.70	3	27.5	34.8	25.5	27.5
10.4	13.0	13.0	10.4	7.6	6.8	2.6	8.4	10.8	4.2	5.0	1.8	4.6	3.5	6.3	4.8	3.5	2.80	2	28.6	36.0	26.7	27.8
10.8	13.8	12.2	10.3	6.8	6.0	2.5	-----	-----	3.7	4.6	1.4	5.0	3.5	6.3	4.7	3.5	3.00	1	30.3	36.2	28.2	26.0
10.8	13.7	12.1	10.1	6.0	5.4	2.5	8.0	9.4	3.5	3.8	1.3	4.5	3.4	5.6	4.5	3.4	2.95	3	29.3	35.7	27.3	24.8
10.0	13.2	12.2	10.0	6.6	6.4	2.1	8.5	10.8	3.7	4.4	1.9	4.3	3.4	6.3	5.0	3.1	3.20	1	30.0	36.0	26.5	28.0
9.8	12.8	11.4	9.8	6.0	5.4	2.2	7.3	9.4	3.7	3.9	1.8	4.5	3.5	6.0	4.8	2.9	3.05	3	27.6	34.0	25.3	24.2
9.8	12.8	11.9	9.7	7.1	5.6	2.1	8.0	10.6	4.0	4.5	2.0	4.2	3.5	7.8	5.2	3.3	2.95	4	28.3	36.1	26.1	28.2
11.0	14.1	13.7	10.5	7.3	6.3	2.7	7.5	10.0	3.3	5.0	1.0	4.5	3.7	7.1	5.5	3.3	2.65	4	28.7	33.6	26.4	28.3
10.5	13.6	12.7	10.5	6.6	5.3	2.9	8.8	10.9	3.7	4.8	1.6	4.0	3.5	7.0	5.1	3.7	7.95	4	30.3	36.8	28.7	27.0
10.5	13.4	12.7	10.0	6.2	6.0	2.5	7.6	11.0	4.0	3.8	2.5	4.8	3.0	5.7	4.7	3.7	2.90	3	-----	-----	-----	-----
10.4	13.4	12.2	10.4	6.3	5.7	2.4	7.1	10.0	4.3	4.4	1.5	5.1	3.2	7.0	4.7	3.4	2.95	-----	30.0	35.7	27.0	28.4
10.3	13.6	12.5	10.0	7.4	6.8	3.0	6.7	11.6	4.0	5.2	2.0	4.5	4.2	7.0	5.6	3.0	3.00	-----	29.0	36.0	28.6	29.0
10.7	13.3	12.0	10.1	6.2	5.8	2.1	8.7	10.0	3.5	4.3	1.7	4.3	3.6	6.0	4.7	3.3	3.00	2	29.3	33.4	28.0	27.6
9.8	13.0	11.6	9.6	6.7	6.3	2.5	7.8	10.4	3.5	4.5	1.5	4.2	3.4	6.4	4.8	3.2	2.60	2	29.5	34.2	26.6	25.1
10.8	12.9	12.0	9.7	6.9	6.4	2.6	8.8	11.1	3.7	4.9	2.1	4.3	3.5	6.2	5.1	3.5	2.80	3	30.7	36.8	27.3	29.2
10.2	13.5	12.4	10.2	7.1	6.3	2.2	8.8	10.6	3.9	4.6	1.7	5.0	3.7	6.9	5.3	3.5	2.75	3	30.0	35.4	29.0	26.5
10.6	12.6	11.5	10.2	6.6	6.1	2.5	8.0	10.5	3.6	4.2	2.3	4.5	3.4	5.7	4.5	3.4	2.80	3	30.7	35.0	28.0	25.5
10.0	12.0	11.1	9.6	6.2	5.9	2.2	8.2	9.7	3.2	4.7	1.0	4.5	3.2	5.7	4.4	3.1	2.70	4-5	28.4	36.0	26.0	28.4
10.0	13.0	11.8	9.5	6.2	5.7	2.5	8.0	10.1	3.4	4.1	1.5	3.9	3.0	6.0	4.1	3.4	2.90	-----	28.0	34.0	26.8	25.3
9.8	12.8	12.3	10.0	6.8	6.1	2.4	6.7	10.7	3.6	4.4	1.7	4.3	3.3	6.1	4.3	3.4	2.80	4	29.8	36.0	27.0	28.0
10.0	13.1	12.3	10.1	6.7	6.0	3.0	8.4	10.0	3.7	4.7	1.5	5.0	3.5	6.3	4.8	3.2	2.90	3	29.0	36.0	26.0	26.0
10.1	13.6	12.5	10.3	6.0	5.8	2.1	7.2	10.0	3.4	3.9	2.2	4.7	3.4	6.0	4.6	3.7	2.65	2	29.6	36.2	26.5	28.4
10.0	13.0	12.0	10.4	6.4	6.2	2.0	8.6	10.6	3.7	4.5	1.7	4.5	3.3	5.4	4.1	2.7	2.70	2	28.0	35.0	26.0	24.0
9.7	13.7	12.1	11.1	7.0	6.5	2.6	7.1	10.7	4.0	4.7	1.8	4.8	3.3	6.8	4.6	3.4	2.80	3-4	30.2	35.7	28.0	25.0
9.6	12.5	11.6	10.0	7.2	6.4	2.8	8.6	11.3	3.7	5.0	2.0	5.0	3.4	6.7	4.9	3.2	2.90	3	29.8	36.5	26.0	27.3
9.5	12.3	11.2	9.5	6.4	6.0	3.1	7.8	9.0	3.7	4.9	1.2	5.0	3.6	6.2	4.5	3.4	2.55	3	27.8	34.2	26.0	26.5
10.0	13.5	12.8	10.2	7.8	7.0	2.0	5.4	12.2	4.0	5.0	2.0	4.7	3.5	6.3	5.0	3.7	2.70	4-5	31.3	37.0	28.0	26.0
10.1	13.1	12.2	10.0	7.4	6.7	2.9	8.0	10.8	3.8	4.9	2.0	4.8	3.2	6.3	4.9	4.0	2.75	5	29.0	33.7	27.0	26.0

TABLE 1.—Actual measurements, in

Serial No.	Clinical No.	Age.	Stature.	Body.														Head.		
				Sitting height.	Pubic height.	Umbilical height.	Sternum height.	Chin height.	Ear height.	Ankle height.	Knee height.	Trochanter height.	Finger-tip height.	Wrist height.	Elbow height.	Acromion height.	Maximum.			
																	Length.	Breadth.	Height.	
41	712	65	143.0	72.3	77.5	90.2	116.5	125.5	132.4	5.2	38.6	76.0	48.0	65.5	87.8	117.0	16.8	14.2	11.5	
42	711	30	140.8	73.8	72.5	87.6	114.0	119.4	129.0	5.3	37.4	74.4	48.0	63.2	84.7	115.5	17.2	14.0	12.1	
43	735	30	153.7	79.9	85.8	96.2	124.0	130.5	140.2	5.6	39.6	80.8	58.0	74.0	95.0	126.0	17.6	14.5	12.5	
44	741	36	147.2	78.9	74.70	88.5	117.0	124.0	135.0	5.0	38.5	74.0	46.7	64.0	87.3	119.7	17.1	14.0	12.0	
45	762	(*)	152.2	80.5	77.2	93.0	122.0	128.0	138.5	4.9	41.4	80.5	55.0	71.7	92.7	122.8	17.2	14.6	12.3	
46	822	70	136.8	73.3	70.5	81.0	109.5	115.0	125.0	5.2	36.3	71.0	53.0	67.0	86.0	112.0	17.5	14.3	12.5	
47	824	25	148.5	78.1	73.0	87.0	117.0	122.5	132.5	4.5	35.0	73.0	56.8	71.3	92.3	118.0	17.4	14.8	12.4	
48	823	38	152.2	82.9	76.5	91.8	122.5	131.3	141.0	5.3	38.2	78.0	53.2	70.0	90.5	124.4	18.1	13.8	11.8	
49	771	50	140.3	73.2	72.8	85.8	113.0	120.5	130.5	4.5	36.8	71.8	50.0	66.2	86.3	113.0	16.5	14.1	11.3	
50	752	18	149.8	76.3	80.8	92.5	122.3	128.6	138.0	5.2	40.5	80.0	55.0	71.6	93.2	123.0	16.2	14.1	11.5	
51	745	30	154.8	82.7	80.0	94.3	125.4	131.0	142.5	6.2	41.6	83.0	55.3	73.0	93.5	127.5	18.1	14.2	12.3	
52	-----	46	150.3	79.0	77.0	89.8	118.0	127.3	136.4	6.2	38.8	76.7	52.5	68.0	90.5	121.0	17.3	14.6	12.0	
53	-----	30	145.2	79.3	74.3	90.6	116.2	122.3	133.0	4.5	37.5	75.8	50.8	67.5	88.5	119.0	17.9	15.1	12.8	
54	957	25	147.8	78.8	75.5	90.0	119.0	125.6	135.5	5.5	40.2	80.7	54.5	69.0	91.2	117.6	17.5	14.2	12.0	
55	859	33	142.5	76.0	73.0	87.3	114.5	121.8	130.0	5.0	39.0	73.8	53.0	69.0	89.5	116.0	16.7	14.6	11.8	
56	729	35	153.0	79.9	75.6	94.0	122.6	129.5	138.8	6.8	42.8	79.7	56.4	72.7	95.2	125.0	17.2	15.0	12.0	
57	818	25	150.4	77.7	79.7	93.0	123.0	130.0	137.0	5.1	43.4	81.0	54.5	70.3	92.3	123.0	18.8	14.9	12.4	
58	817	60	138.0	71.3	72.5	87.0	112.0	117.0	127.5	5.0	37.0	72.7	47.0	62.0	82.5	110.0	17.5	14.5	11.8	
59	821	50	142.8	77.0	72.3	83.0	113.6	120.0	129.0	5.7	38.5	71.8	51.8	68.5	89.3	114.4	17.5	15.1	13.0	
60	-----	38	155.8	79.0	79.70	95.6	126.0	131.0	142.0	5.8	44.0	84.5	58.4	74.0	95.8	128.6	18.0	14.1	12.3	
61	-----	32	147.0	76.78	70.8	88.0	119.1	124.0	135.0	5.3	38.0	73.3	54.0	69.6	90.5	119.6	17.5	15.0	12.5	
62	955	30	140.0	75.1	72.5	84.4	113.0	120.5	126.7	5.6	38.8	72.0	50.8	64.2	87.6	114.4	16.6	14.5	12.0	
63	920	30	148.8	81.0	75.8	91.7	118.6	125.4	135.2	4.7	40.0	78.3	52.0	68.0	87.8	118.3	18.5	14.0	11.7	
Average.	39.8	147.8	78.5	75.8	89.9	119.3	125.9	135.3	5.5	39.5	76.8	53.9	70.15	91.1	121.0	17.5	14.5	12.1		

* Adult.

centimeters—the women of Taytay—Continued.

Head.

Forehead width.	Bizygomatic diameter.	Bimastoid diameter.	Bigoniac diameter.	Naso-buccal.	Naso-alveolar.	Nose base.	Nasion hair-line.	Chin-nasion.	Nose width.	Nose length.	Mouth width.	Mouth length.	Ear width.	Ear length.	Ear cartilage.	Interocular distance.	Eye length.	Eye color.	Frontal circumference.	Parietal circumference.	Forehead circumference.	Occipital circumference.
9.5	12.7	11.7	10.0	6.6	6.2	2.6	6.6	9.5	4.3	4.6	0.5	4.8	3.8	6.7	5.1	3.8	2.50	2-3	28.2	34.0	26.3	24.5
9.5	12.4	11.6	9.6	6.3	5.8	2.4	7.3	9.7	3.7	3.8	2.2	4.2	3.6	6.4	5.2	2.7	2.65	2	27.5	34.2	25.5	26.5
10.1	12.7	12.0	9.6	6.7	6.7	2.4	8.0	11.3	3.4	4.5	1.8	4.2	3.0	6.0	4.5	3.4	2.65	2	28.8	36.0	27.0	28.0
10.4	12.8	11.5	10.1	6.4	5.6	2.8	-----	-----	3.5	4.6	2.1	4.7	3.4	6.1	4.6	3.2	2.90	1-2	28.8	35.0	26.2	25.4
10.2	13.7	12.6	10.0	6.8	5.8	2.7	8.0	10.3	4.0	4.6	1.8	4.3	3.6	6.6	5.2	3.1	3.15	2-3	28.7	35.5	27.7	27.7
10.2	12.7	11.7	9.4	6.5	5.8	2.1	8.5	10.3	4.3	4.1	2.3	4.5	3.7	6.3	4.9	3.8	2.55	3-4	28.6	34.5	27.0	28.0
10.1	13.5	12.1	10.2	6.8	5.9	2.3	7.5	10.3	3.9	4.4	1.8	5.0	3.5	6.3	4.7	3.7	2.95	2	30.0	34.4	28.0	24.5
10.0	12.8	11.6	9.7	6.6	5.8	2.6	7.1	10.4	3.5	4.3	2.0	4.6	3.4	6.6	4.7	3.0	2.90	3	29.0	33.4	27.6	26.2
10.5	13.0	11.5	10.0	5.8	5.3	1.8	6.4	9.3	3.7	3.7	1.7	4.1	3.0	5.4	4.2	3.5	2.75	4	29.4	33.5	27.0	24.78
10.0	12.7	12.0	9.7	6.1	5.3	2.4	7.3	9.1	3.6	4.3	2.1	4.2	3.0	6.0	4.9	3.3	3.00	1-2	28.4	33.3	24.5	26.5
10.5	13.1	12.5	10.1	6.6	6.0	3.0	7.4	11.2	3.7	4.6	1.8	4.3	3.3	6.1	4.8	3.6	2.80	3	28.5	33.0	27.0	27.0
10.0	13.3	13.0	11.0	6.5	5.8	2.8	9.0	9.5	4.3	4.7	1.7	5.5	3.5	6.8	5.5	3.0	2.80	3	28.0	35.0	27.0	26.5
11.5	13.8	12.5	10.7	7.0	6.0	2.6	6.2	10.2	4.0	4.4	2.0	4.4	3.0	5.8	4.5	3.6	3.25	3	29.5	35.3	28.5	27.5
10.3	12.4	12.0	9.3	6.5	6.0	2.7	7.8	10.5	3.5	4.1	2.0	4.2	3.7	5.5	4.5	3.2	2.90	3	29.8	35.5	26.7	26.7
9.8	12.5	10.8	10.0	6.3	5.5	2.4	7.4	9.6	3.7	4.4	2.0	4.8	2.7	5.7	4.2	3.3	2.85	2-3	28.2	34.8	26.0	25.0
10.2	13.2	12.4	10.5	6.6	5.4	2.6	8.2	10.4	4.2	4.6	1.9	4.0	3.6	6.5	5.2	3.2	2.75	3	28.6	36.5	25.8	27.3
10.4	13.2	12.7	9.6	6.0	5.6	2.6	9.2	10.2	4.2	4.3	2.0	5.0	3.3	6.2	4.8	3.3	3.25	2	30.6	37.2	27.8	28.5
10.4	13.3	12.3	10.2	7.0	6.2	2.8	9.8	10.5	3.8	4.5	2.0	4.5	3.8	6.7	5.0	3.6	2.60	4	29.4	33.0	23.0	25.0
10.7	13.2	12.4	10.3	7.0	6.3	2.7	7.7	11.2	3.7	4.5	2.8	4.0	3.7	6.9	5.1	3.4	2.80	-----	31.0	35.7	27.7	25.7
10.5	14.1	12.6	11.0	6.8	6.2	3.0	7.7	11.4	3.8	4.9	1.7	5.0	3.2	6.3	5.1	3.3	3.15	4	29.3	36.0	27.0	28.0
10.5	13.2	12.3	10.0	6.2	5.9	2.4	8.4	10.0	3.7	4.0	2.4	4.8	3.1	6.1	4.3	3.5	2.75	3	31.0	36.5	28.0	27.0
10.5	13.2	13.2	9.7	6.7	5.9	2.6	8.4	10.2	3.8	4.1	2.3	4.4	3.3	5.7	4.3	3.4	2.90	2	29.2	33.8	26.4	25.5
10.4	13.1	12.1	10.0	6.8	6.2	2.7	8.4	11.2	3.7	4.3	1.7	4.8	3.4	6.2	-----	3.8	2.80	4	29.8	34.2	28.0	26.6
10.2	13.1	12.1	10.0	6.6	5.9	2.45	7.8	10.3	3.75	4.4	1.7	4.5	3.4	6.2	4.7	3.3	2.93	3	29.3	35.1	26.8	26.9

TABLE II.—Indices and calculated

Species of individuals.	Number.	Clinical No.	Absolute lower leg length.	Relative lower leg length.	Absolute upper leg length.	Relative upper leg length.	Absolute hand length.	Relative hand length.	Absolute forearm length.	Relative forearm length.	Absolute upper arm length.	Relative upper arm length.	Fibula to umbilicus.	Umbilicus to sternum.	O m p h a l i c Index.
Australoid	1	428	35.5	25.2	28.8	20.5	15.4	10.9	17.0	12.1	29.0	20.6	13.1	30.8	42.5
Primitive	2	407	37.4	24.8	35.5	23.5	17.0	11.2	22.2	14.7	27.8	18.4	17.7	28.0	63.2
Primitive	3	398	31.4	21.3	38.5	26.1	17.7	12.0	19.0	12.9	30.3	20.6	16.37	28.9	56.3
Primitive	4	429	33.2	22.0	39.6	26.2	15.7	10.4	22.2	14.6	32.8	21.7	17.1	28.1	60.8
Australoid	5	427	33.3	22.8	36.6	25.2	16.4	11.1	20.4	13.8	30.4	20.6	17.5	27.5	63.6
Australoid	6	468	35.7	23.8	36.9	24.7	16.8	11.2	19.6	13.1	30.2	20.2	13.2	29.5	44.5
Blend	7	445	30.4	21.5	36.5	25.8	16.0	11.3	18.6	13.1	28.4	20.0	10.5	30.8	34.0
Iberian	8	443	30.5	21.3	35.2	24.6	16.2	11.3	19.0	13.2	27.5	19.2	13.5	30.8	43.8
Primitive	9	444	33.3	23.4	35.3	25.1	16.3	11.4	20.9	14.7	28.5	20.0	13.4	28.2	47.5
Iberian	10	-----	33.9	23.7	33.6	23.5	16.4	11.4	17.8	12.4	30.5	21.3	13.9	28.9	48.1
Blend	11	460	32.8	22.3	38.3	26.1	16.3	11.1	20.7	14.1	28.2	19.0	17.5	27.7	47.9
Iberian	12	-----	31.3	21.3	39.2	26.7	15.4	10.5	21.8	14.8	30.5	20.8	12.4	30.4	40.7
Primitive	13	468	33.7	22.5	37.2	24.9	15.5	10.3	20.5	13.7	30.7	20.5	13.2	29.6	44.6
B. B. B.	14	499	33.8	22.5	38.2	25.4	15.4	10.2	20.9	13.9	31.7	21.1	12.4	27.3	45.4
Blend	15	-----	?	-----	?	-----	15.2	10.1	21.3	14.2	28.0	18.7	17.5	27.2	64.3
Primitive	16	262	33.5	22.4	37.7	25.3	15.6	10.4	21.6	14.5	29.2	19.6	14.3	29.9	47.8
Iberian	17	498	36.6	24.3	31.5	20.9	14.0	9.3	23.0	15.3	30.2	20.0	20.87	25.4	73.2
Blend	18	-----	30.1	20.9	37.8	26.2	17.8	12.3	19.2	13.3	30.5	21.2	15.9	26.1	60.9
Blend	19	507	34.3	22.9	39.5	26.3	15.7	10.4	23.5	15.7	29.5	19.7	11.4	32.2	35.4
B. B. B.	20	433	34.0	21.8	41.5	26.7	17.5	11.2	19.1	12.3	31.3	20.1	12.4	33.0	37.6
Iberian	21	512	36.2	23.3	40.5	26.0	17.2	11.0	23.0	14.8	30.2	19.4	14.8	29.9	49.5
Adriatic	22	-----	34.2	21.9	44.0	28.2	16.3	10.4	21.3	13.6	33.7	21.6	12.7	32.7	38.8
Australoid	23	506	33.5	22.4	38.0	25.4	16.3	10.9	20.5	13.7	34.5	23.0	13.2	30.7	42.9
Iberian	24	213	34.0	21.8	40.9	26.2	16.6	10.6	23.1	14.8	32.0	20.5	11.2	34.6	32.3
Iberian	25	524	37.0	24.0	36.8	23.9	16.0	10.3	21.0	13.6	30.0	19.4	15.1	32.1	47.0
Iberian	26	2	37.9	24.6	38.0	24.7	17.4	11.3	21.0	13.6	32.5	21.1	16.3	27.2	59.9
Iberian	27	221	34.9	22.4	41.9	26.9	14.1	9.1	23.4	15.0	31.2	20.0	15.2	30.6	49.6
Iberian	28	253	32.4	21.3	40.5	26.6	17.6	11.5	21.4	14.0	28.0	18.4	16.7	29.6	56.4
Iberian	29	-----	32.2	21.4	40.3	26.8	17.2	11.4	21.9	14.5	30.7	20.4	14.7	30.5	48.2
Iberian	30	572	36.6	25.4	35.0	24.2	15.8	10.9	19.4	13.3	28.4	19.7	11.6	29.6	39.2
Blend	31	578	30.1	20.9	35.3	24.5	16.0	11.1	20.0	13.9	31.0	21.5	14.0	32.3	46.4
Iberian	32	645	32.0	22.2	34.6	24.0	16.3	11.3	19.1	13.2	27.6	19.1	16.1	29.5	54.5
Blend	33	677	33.8	20.8	39.2	23.9	16.8	10.3	20.8	12.8	30.5	18.7	11.3	33.2	34.0
Blend	34	625	33.2	21.3	40.3	25.9	17.0	10.9	21.4	13.7	32.3	20.7	11.6	31.5	36.8
Blend	35	664	31.9	21.7	34.6	23.5	15.5	10.5	21.0	14.3	30.5	20.7	16.5	30.5	54.0
Blend	36	699	32.6	21.8	39.0	26.1	17.0	11.4	18.5	12.4	29.2	19.6	14.0	29.2	47.9
Iberian	37	70	34.5	22.8	40.0	26.4	17.4	11.5	20.6	13.6	30.0	19.8	14.4	28.5	50.5
Iberian	38	690	32.1	22.0	36.5	25.1	15.8	10.8	19.5	13.4	-----	-----	12.0	31.2	38.4
Alpine	39	-----	33.8	23.3	38.3	26.4	17.3	11.9	23.9	16.5	29.8	20.5	10.3	31.2	33.0
Iberian	40	698	34.7	23.2	37.3	24.9	16.5	11.0	22.5	15.0	29.2	19.5	13.0	29.5	44.0
Blend	41	712	33.4	23.3	37.4	26.1	17.5	12.2	22.3	15.6	29.2	20.4	12.7	26.3	48.2
Australoid	42	711	32.1	22.8	37.0	26.2	15.2	10.7	21.5	15.2	30.8	21.8	15.1	26.4	57.2
Blend	43	735	34.0	22.1	41.2	26.8	16.0	10.4	21.0	13.6	31.0	20.1	10.4	27.8	37.4
Iberian	44	741	33.5	22.7	35.5	24.1	17.3	11.7	23.3	15.8	32.4	21.9	14.5	28.5	50.8

factors—women of Taytay.

Total head height.	Upper face height.	Cephalic index.	Nasal index.	Type of individuals.	Physiognomic face index.	Morphologic face index.	Combined face index.	Ear type.
22.2	12.0	73.80	107.14	Australoid	71.4	78.4	109.8	Iberian C.
22.0	12.4	89.15	90.00	Blend	79.0	70.5	89.1	Mixed B. B. B.
23.4	12.4	86.85	83.33	Blend	80.0	73.5	91.8	Primitive.
23.5	13.0	86.98	90.47	Blend	77.1	77.7	100.7	Mixed.
21.77	11.37	77.10	102.40	Australoid	68.2	81.9	120.0	Iberian C.
21.4	10.4	78.57	86.66	Australoid	72.6	84.6	116.5	Iberian C.
19.4	9.4	84.30	85.71	Blend	74.1	77.5	104.5	Iberian A, D, C, Primitive.
23.2	11.5	82.32	75.00	Blend	64.6	89.9	139.1	Iberian C.
20.7	12.0	87.11	114.70	Primitive	83.3	66.9	80.3	
23.3	12.9	84.30	77.08	Blend	71.5	79.3	110.9	Mixed.
21.8	10.8	82.49	81.25	Blend	68.2	86.6	126.9	Iberian C and D.
20.3	11.0	77.89	74.78	Iberian	66.1	74.4	112.5	Iberian C and D.
20.1	10.4	84.61	100.00	Modified Primitive	75.6	72.9	96.4	Iberian D.
23.2	12.4	90.53	84.00	Alpine or B. B. B.	71.3	79.0	110.8	Mixed Iberian, B. B. B.
22.9	11.5	87.71	80.43	Blend				Iberian C and D.
20.7	11.3	95.57	92.10	Modified Primitive	78.7	68.6	87.1	Primitive, odd type.
21.6	10.8	79.44	84.10	Blend	68.6	81.8	119.2	Iberian D and C.
20.3	10.9	85.88	94.87	Blend	76.6	73.4	95.8	Iberian B and C.
22.7	12.1	83.43	88.88	Blend	68.8	82.8	120.3	Iberian C.
23.3	13.3	85.50	66.00	B. B. B.	80.5	70.9	88.0	Iberian C.
24.5	13.6	77.72	77.07	Iberian	69.0	80.1	116.0	Iberian C and D.
22.2	11.2	87.00	105.26	Adriatic	72.0	81.9	113.7	Mixed Iberian ?
22.3	12.3	80.11	97.75	Australoid	78.3	74.6	95.2	Iberian C and D.
23.5	11.9	80.54	76.92	Blend	74.3	85.2	114.6	B. B. B., Iberian D.
21.0	11.0	77.77	81.39	Iberian	71.1	75.1	105.6	Iberian, B. B. B., Primitive.
22.8	12.4	81.28	77.77	Blend	71.4	80.0	112.0	Iberian D.
23.9	12.8	78.33	75.51	Iberian	64.8	86.0	132.7	Iberian and Primitive.
22.0	11.4	79.00	84.78	Blend	69.5	78.5	112.9	B. B. B.
23.3	12.8	77.46	85.71	Iberian	68.1	83.3	122.3	Iberian C and D.
21.1	11.4	78.68	68.08	Iberian	67.0	80.8	120.6	Iberian A.
20.3	10.2	83.33	82.92	Blend	71.8	77.6	108.0	Iberian D.
21.5	10.8	79.46	81.81	Blend	73.5	83.5	113.6	B. B. B., Iberian.
31.47	21.47	89.75	78.72	Blend	71.1	76.3	107.3	Iberian C and D.
22.4	12.4	83.14	87.17	Blend	79.0	73.5	93.0	Mixed Primitive.
22.1	11.5	87.50	82.22	Blend	67.7	81.5	120.4	Mixed Iberian.
23.3	14.6	81.00	85.10	Blend	76.9	78.1	101.5	B. B. B., Iberian.
24.0	12.7	76.06	74.00	Iberian	62.8	90.4	143.9	Iberian D.
21.7	12.7	78.85	75.51	Iberian	73.2	73.1	99.8	Iberian D.
20.7	8.5	95.23	80.00	Alpine	76.7	90.3	117.7	Iberian B, Alpine.
19.8	9.0	78.33	77.50	Iberian	69.6	82.4	118.4	Iberian D.
17.5	8.0	84.52	93.47	Blend	78.8	74.8	94.9	Iberian D.
21.4	11.7	81.39	97.30	Australoid	72.9	78.1	107.1	Iberian D.
23.2	11.9	82.38	75.55	Blend	65.8	88.9	135.1	Odd type Iberian.
23.2	11.5	81.87	76.08	Blend				B. B. B., Iberian.

TABLE II.—Indices and calculated

Species of individuals.	Number.	Clinical No.	Absolute lower leg length.	Relative lower leg length.	Absolute upper leg length.	Relative upper leg length.	Absolute hand length.	Relative hand length.	Absolute fore-arm length.	Relative fore-arm length.	Absolute upper arm length.	Relative upper arm length.	Pubis to umbilicus.	Umbilicus to sternum.	O m p h a l i c index.
Blend	45	762	36.5	23.9	39.1	25.6	16.7	10.9	21.0	13.8	30.1	19.7	15.8	29.0	54.4
Australoid	46	822	31.1	22.7	34.7	25.3	14.0	10.2	19.0	13.8	26.0	19.0	10.5	28.5	36.8
Blend	47	824	30.5	21.2	38.0	26.4	14.5	10.1	21.0	14.6	25.7	17.9	14.0	30.0	46.6
Iberian	48	823	32.9	21.6	39.8	26.1	16.8	11.0	20.5	13.4	33.9	22.2	15.3	30.7	49.5
Primitive	49	771	32.3	23.0	35.0	25.6	16.2	11.5	20.1	14.3	26.7	19.0	13.0	27.2	47.7
Blend	50	752	35.3	23.5	39.5	26.3	16.6	11.0	21.6	14.4	29.8	19.8	11.7	29.8	39.2
Iberian	51	745	35.4	22.8	41.4	26.7	17.7	11.4	20.5	13.2	34.0	21.9	14.3	31.1	45.9
Blend	52	-----	32.6	21.6	37.9	25.2	15.5	10.3	22.5	14.9	30.5	20.2	12.8	28.2	45.3
Blend	53	-----	33.0	22.7	38.3	26.3	16.7	11.5	21.0	14.4	30.5	21.0	16.3	25.6	63.6
Blend	54	957	34.7	23.8	40.5	27.1	14.5	9.9	22.2	15.2	26.4	18.1	14.5	29.0	50.0
Primitive	55	859	34.0	23.8	34.8	24.4	16.0	11.2	20.5	14.3	26.5	18.5	14.3	27.2	52.5
Blend	56	729	36.0	23.5	36.9	24.1	16.3	10.6	22.5	14.6	29.8	19.5	18.4	28.6	64.3
Australoid	57	818	38.3	25.4	37.6	25.0	15.8	10.5	22.0	14.5	30.7	20.4	13.3	30.0	44.3
Blend	58	817	32.0	23.1	35.7	25.8	15.0	10.8	20.5	14.8	28.0	20.2	14.5	25.0	58.0
Blend	59	821	32.8	22.9	33.3	23.3	16.7	11.7	20.8	14.5	25.1	17.5	10.7	30.6	34.9
Iberian	60	-----	38.2	24.5	40.5	25.9	15.6	10.0	21.8	13.9	32.8	21.0	16.6	30.4	54.6
Primitive	61	-----	32.7	22.2	35.3	24.0	15.6	10.6	20.9	14.2	29.1	19.8	17.2	31.0	55.4
Primitive	62	955	33.2	23.7	33.2	23.7	13.4	9.5	23.4	16.7	26.8	19.1	11.9	23.6	41.6
Australoid	63	920	35.3	23.7	38.3	25.7	16.0	10.7	19.8	13.3	30.5	20.4	15.9	26.9	59.1
Average	-----	-----	33.7	22.7	37.5	25.2	16.1	10.8	20.9	14.1	29.8	20.1	14.0	29.4	48.2

factors—women of *Taytay*—Continued.

Total head height.	Upper face height.	Cephalic Index.	Nasal Index.	Type of individuals.	Physiognomic face index.	Morphologic face index.	Combined face index.	Ear type.
24.2	13.9	84.88	86.95	Blend	74.8	75.1	100.4	B. B. B., Iberian mixed.
21.8	11.5	81.71	104.80	Australoid	67.5	81.1	120.1	Mixed B. B. B.
21.0	10.7	87.06	88.63	Blend	75.8	76.3	100.6	Iberian C.
20.9	10.5	76.42	81.39	Iberian	73.1	81.2	111.0	Iberian C.
19.8	10.5	85.45	100.00	Primitive	82.8	71.5	86.3	Iberian mixed.
21.8	12.7	87.03	83.71	Blend	77.4	71.6	92.5	Primitive, Iberian.
23.8	12.6	78.45	80.43	Iberian	70.4	85.4	121.3	B. B. B., Iberian.
23.0	13.5	84.39	91.48	Blend	71.8	71.4	99.4	Iberian D.
22.9	12.7	84.35	90.90	Blend	84.1	73.9	87.8	Iberian C mixed.
22.2	11.7	81.14	85.36	Blend	67.7	84.6	124.0	Iberian B.
20.7	11.1	87.42	84.09	Blend	73.5	76.8	104.4	Primitive.
23.5	13.1	87.20	91.30	Blend	70.9	78.7	111.0	Mixed.
20.4	10.2	79.20	97.60	Blend	68.0	77.2	113.5	B. B. B., Iberian.
21.0	10.5	82.09	84.44	Blend	65.5	78.9	120.4	Mixed Iberian.
22.8	11.6	86.20	82.20	Blend	69.8	84.8	121.3	Iberian., B. B. B.
24.8	13.4	78.33	77.55	Iberian	73.8	80.8	109.4	Mixed Iberian.
23.0	13.0	85.71	92.50	Blend	71.7	75.7	105.5	B. B. B. mixed.
19.5	9.3	87.35	92.68	Blend	70.9	77.2	108.8	Mixed Primitive.
23.4	12.2	75.70	86.04	Australoid	66.8	85.4	127.8	Iberian.
22.2	11.8	82.93	86.00			79.1		



ILLUSTRATIONS.

PLATE I. WOMEN OF TAYTAY.

- FIG. 1. Iberian (D).
2. Primitive (Blend).
3. Dwarf.
4. Primitive (Blend).
5. B. B. B.

PLATE II. WOMAN OF TAYTAY.

- FIG. 1. Primitive (Blend). Side view
2. Primitive (Blend). Front view.

PLATE III. WOMAN OF TAYTAY.

- FIG. 1. Primitive (Blend). Front view.
2. Primitive (Blend). Side view.

PLATE IV. WOMAN OF TAYTAY.

- FIG. 1. Iberian (D). Front view.
2. Iberian (D). Side view.

PLATE V. WOMAN OF TAYTAY.

- FIG. 1. A Modified B. B. B. type. Front view.
2. A Modified B. B. B. type. Side view.

PLATE VI. WOMAN OF TAYTAY.

- FIG. 1. Primitive (Blend). Front view.
2. Primitive (Blend). Side view.

PLATE VII. A DWARF OF TAYTAY.

- FIG. 1. Front view.
2. Side view.

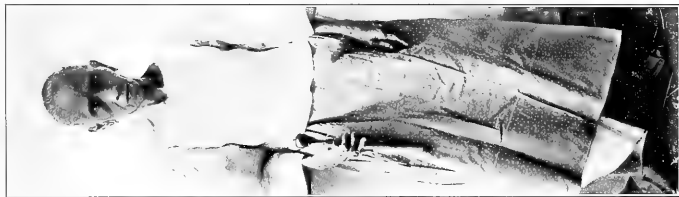

FIG. 1. IBERIAN (D).

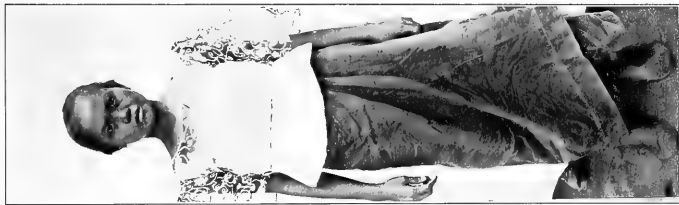

FIG. 2. PRIMITIVE (BLEND).



FIG. 3. DWARF.



FIG. 4. PRIMITIVE (BLEND).



FIG. 5. B. B. B.

PLATE I.



FIG. 1. SIDE VIEW.



FIG. 2. FRONT VIEW.

PLATE II.



FIG. 1. FRONT VIEW.



FIG. 2. SIDE VIEW.

PLATE III.



FIG. 1. FRONT VIEW.



FIG. 2. SIDE VIEW.

PLATE IV.



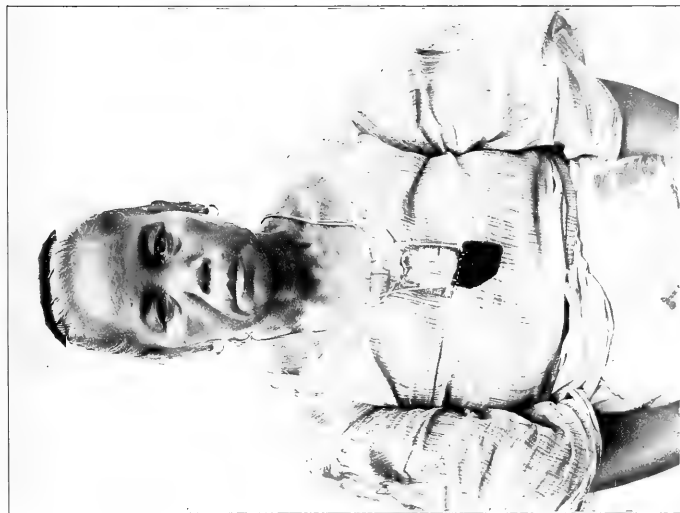

FIG. 1. FRONT VIEW.



FIG. 2. SIDE VIEW.

PLATE V.





FIG. 1. FRONT VIEW.



FIG. 2. SIDE VIEW.





FIG. 1. FRONT VIEW.



FIG. 2. SIDE VIEW.

PLATE VII.



ILLUSTRATION.

PLATE I.

FIGS. 1 and 2. *Homò Philippinensis*.

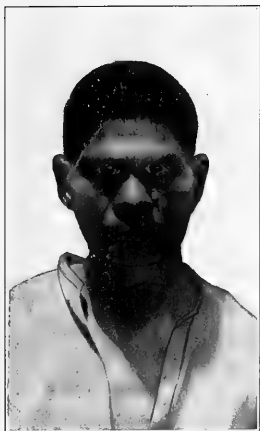

PLATE I.



PALEOLITHIC MAN IN THE PHILIPPINES. HOMO PHILIPPINENSIS.

By ROBERT BENNETT BEAN.

(From the Anatomical Laboratory, Philippine Medical School, Manila, P. I.)

The discovery of a lower jaw at Mauer, near Heidelberg, by Dr. Otto Schoetensack, on October 21, 1907, marks the earliest form of man yet found in Europe. This man has been called *Homo heidelbergensis*, and the jaw is peculiar in that it unites two seemingly contradictory qualities: massiveness of jaw with absence of chin ("negative chin formation," H. Klaatsch), and an especially square, ascending ramus, qualities called pithecoïd. *Homo heidelbergensis* belongs to the earliest paleolithic age, or to the transition period from Diluvium to late Tertiary (pliocene).

Another early paleolithic form was recently discovered in the lower grotto of Le Moustier (Dordogne), where a skeleton was unearthed bearing the marks of the older Diluvial race, resembling the Neanderthal type. The massive proportions of the chinless jaw are remarkable. The femur is extraordinarily short, the length is estimated at 19.5 centimeters, and the lower extremities are necessarily short.

Another find of great importance occurred in France near La Chapelle-aux-Saints (Correze) on August 3, 1908, in the form of a skeleton of a man in an absolutely undisturbed stratum, by the Abbés A. and J. Bouyssonie and L. Bardon. The subject was an old man of about 160 centimeters stature. The skull is dolichocephalic, with an index of 75; its height is small; the huge round orbits and wide nasal apertures resemble the Neanderthal skulls. The face is prognathous and the mandible is very large, with absence of chin.

The cultural and fossil findings in connection with the remains place them in three succeeding periods of time, *Homo heidelbergensis* being older, and the other two more recent and of about the same date, but all of great antiquity.

Men of similar form may be seen in the Philippines to-day, rarely, it is true, but the close observer who lives among the people of different parts of the Archipelago for years can hardly fail to notice such types. It was my good fortune to make observations and measurements of such a man at Taytay, in the Province of Rizal, Island of Luzon, on April 5, 1909, during my anthropometric survey of the town. The man came to the clinic of the Free Dispensary which was being operated during the survey and was treated for sexual neurasthenia. He disappeared as

quietly as he came, and I was unable to find him again. He did not live in Taytay, and some of the people there said that he came in from the hills that lie immediately back of the town. I endeavored to obtain a photograph, but unfortunately the Government photographer was absent on that day and the only camera available was inadequate. However, this was utilized and the resulting photographs are reproduced here for the first time. (See Plate I, figs. 1 and 2.)

The features of this man are large and heavy, the lower jaw is heavy, long, square and narrow, with "negative chin formation." The brow ridges protrude, the cheeks are large and prominent, the nose is massive, wide, straight and depressed at the nasion, and the lips are full and thick. The brow ridges are noticeably prominent. The upper lip is broad from its border to the nasal spine, a distance of 2.7 centimeters, and the peculiarity of it is the rounded contour between the nasal spine and lip margin as seen in profile. The face is prognathous, the facial angle 70° —glabella, nasal spine, external auditory meatus—is not greater nor less than that of many other Filipinos, although it is 7° to 8° less than that of the Igorots measured in the same way. Nevertheless, about 30 per cent of the Igorots have the same index and 4 per cent one of less than 70° . The nasal index is 102.2, the cephalic 73.68, and the stature 156.8 centimeters. The head height from the upper part of the external auditory meatus to the bragma is 12.5 centimeters. The ear is a combination of Primitive and Iberian, and should be called the Australoid ear. The orbits are large and round, the forehead is low and the glabella is prominent. The sagittal head outline is low, long, and somewhat flat over the lambda, and might very well represent the combined Primitive and Iberian head outline in the form of the Australoid. The type falls within the group I have designated as Australoid, because it is long headed, broad nosed, and small in stature, but this man is a form somewhat apart, typical of neither the *primary* nor the *secondary* Australoid. The following actual dimensions are given to complete the description:

[Name, Alejandro Mesa; age, 55 years.]

	Centi- meters.		Centi- meters.		Centi- meters.
Stature.....	156.8	Head breadth.....	14.0	Lip width (2).....	1.8
Sitting height.....	84.5	Head height.....	12.5	Lip length.....	1.9?
Heel to umbilicus.....	95.5	Bizygomatic diam- eter.....	14.1	Ear breadth.....	3.6
Heel to sternum.....	125.7	Narrowest forehead.....	10.0	Ear length.....	6.2
Heel to pubis.....	81.2	Chin to nasion.....	10.6	Distance between the eyes.....	3.5
Heel to ankle.....	6.7	Nasion to hair line.....	6.0	Distance between the outer corners.....	9.7
Heel to knee.....	44.0	Bimastoid diameter.....	13.0	Eye color by Mar- tin's artificial eyes, No. 3.	
Heel to trochanter.....	80.1	Bigonial diameter.....	10.2	Right handed.	
Heel to finger tip.....	54.0?	Naso-buccal distance.....	7.2		
Heel to wrist.....	73.4	Naso-alveolar dis- tance.....	5.8		
Heel to elbow.....	95.0	Nose height.....	2.3		
Heel to acromion.....	125.6	Nose breadth.....	4.6		
Head length, gla- bella—maximum occipital.....	19.0	Nose length.....	4.5		

The upper leg length, or approximately the femur length, is less than that of the lower leg or tibia, which would give a high crural index, a characteristic of the Australoid type.

A fair consideration of the physical characteristics of this man will show necessarily his close relationship to the Neanderthal type. The massive lower jaw with its square ramus and receding chin; the low cephalic index, heavy brow ridges, rounded orbits, large nasal apertures and high nasal index; the small stature, but muscular frame and the short upper leg or femur, all betoken a form similar to that of the antediluvial man of Europe, *Homo heidelbergensis*.

I believe this is the fundamental type of the Philippines, and it is closely allied to the Australoid, which I have found in groups of individuals from all parts of the Archipelago. Whether this form originated here or elsewhere may not be known, but the probability is that it is a production of the East rather than of Europe, although it may have wandered away from Europe during the ages of ice and cold, coming to the East for a more equable climate. A form resembling the Australoid that has been found in the great islands of the Pacific Ocean, Borneo, Java, Sumatra, Ceylon, Celebes, and in the Malay Peninsula indicates that this may have been their original home.

Whatever the origin of this man there can be no doubt of the presence in considerable numbers of nearly related forms in the Philippine Islands, therefore I propose the name *Homo philippinensis* for this type. The description and measurements given above serve to characterize the type.



RHYNCHOTA PALAWANICA, PART II. HOMOPTERA.

By CHARLES S. BANKS.

(From the Entomological Section, Biological Laboratory, Bureau of Science,
Manila, P. I.)

The first part of this paper, published in this JOURNAL, November, 1909, contained that portion of the Rhynchota of Palawan belonging to the suborder Heteroptera. The remainder of the collections of Messrs. Weber and Schultze, containing the Homoptera, is much smaller but consists of some very interesting forms. A total of 45 species, including 8 new species in 38 genera, one of which is new, is here recorded. Many of the species are noted from these Islands for the first time. The total number of species recorded in this and the previous paper is 130, of which 20 are new, comprising 103 genera, 2 of which are new.

It will be noted that, with the exception of Tara Island and Bacuit, the chief collecting was done in the immediate vicinity of Iwahig, located at about the central portion of the Island of Palawan. There is no doubt but that careful collecting by one familiar with this order would result in our obtaining four or five times as many species both in Heteroptera and Homoptera.

RHYNCHOTA.

HOMOPTERA.

Fam. CICADIDÆ.

Subf. CICADINÆ.

Div. POLYNEURARIA.

PLATYPLEURA Amyot et Serville.

Hist. des Hém. (1843) 465.

Type: *P. stridula* Linn.

1. PLATYPLEURA FULVIGERA Walk.

Platypleura fulviger Walk., List Hom. (1850) 1, 9.

Pacilopsaltria fulviger Stål, Berl. Ent. Ztschr. (1866) 10, 169, Ö. V. A. F.

(1870) 707; Butl., Cist. Ent. (1874) 1, 185; Dist., Mono. Orient.

Cicadid. (1889-1892) 13, pl. 1, fig. 2, a, b, (var.).

PALAWAN, Bacuit and Tara Island, P. I. (11655 and 11721 *C. M. Weber*), 2 specimens. This species is common in all parts of the Philippines. During the months of August and September its songs may be heard at certain hours of the day in any part of the city of Manila.

Div. CICADARIA.

CRYPTOTYMPANA Stål.

Ann. Soc. Ent. Fr. (1861) (4) 1, 613.

Type: *C. pustulata* Fabr.

2. CRYPTOTYMPANA ?VARICOLOR Dist.

Cryptotympana varicolor Dist., *Ann. Mag. Nat. Hist.* (1904) (7) 14, 430,
Fauna British Ind., Rhyn. (1906) 3, 86.

I doubtfully refer the seven specimens to this species. The chief differences between the specimens before me and *C. acuta* Sign., appear to be in their lacking the dorso-lateral white fasciæ on the abdomen and in having the ♂ opercula very long and acute. They extend beyond the caudo-lateral margins of the abdomen and their apices, which are strongly hairy, are about in line with the apex of the penultimate abdominal segment. There is a dark brown median ventral fascia on the abdomen extending to the base of the penultimate segment only in the ♂, while in the ♀ this fascia extends to the apex of the ovipositor. The lateral portions of the sternites in both sexes are covered with golden yellow or white sericeous pile. Distant gives a description of the ♀ only.

PALAWAN, Iwahig, P. I. (10891 *W. Schultze*; 11968 *C. M. Weber*), 7 specimens, 4 ♂ and 3 ♀. This is the first record of this species as from the Philippines if it prove to be *varicolor*.

Div. DUNDUBIARIA.

LEPTOPSALTRIA Stål.

Hcm. Afr. (1866) 4, 5.

Type: *Leptopsaltria tuberosa* Sign.

3. LEPTOPSALTRIA QUADRITUBERCULATA Sign.

Cicada quadrituberculata Sign., *Ann. Soc. Ent. Fr.* (1847) (2) 5, 297.

Dundubia quadrituberculata Walk., *List Hom.* (1850) 1, 78. Stål, *Ann. Soc. Ent. Fr.* (1864) (4) 4, 60.

Leptopsaltria quadrituberculata Stål, *Berl. Ent. Ztschr.* (1866) 10, 170;
Ö. V. A. F. (1870) 710; *Dist., Mono. Orient. Cicadid.* (1892) 31, *pl.* 8, *fig. 6, a, b.*

This fine species, described from Java by Signoret, has been found in China and also in the Philippines, having been taken by Semper. The most striking feature is the presence of the four ventral abdominal tubercles.

PALAWAN, Iwahig, P. I. (10889 W. *Schultze*), 2 ♂ specimens.

DUNDUBIA Amyot et Serville.

Hist. des Hém. (1834) 470.

Type: *D. mannifera* Linn.

4. DUNDUBIA MANNIFERA Linn.

Cicada mannifera Linn., Mus. Ad. Fried. (1754) 84, excl. syn.

Tettigonia vaginata Fabr., Mant. Ins. (1787) 2, 266.

Cicada virescens Oliv., Encycl. Méth. (1790) 5, 747.

Dundubia vaginata Am. et Serv., Hist. des Hém. (1843) 471; *varians*

Walk., List Hom. (1850) 1, 48; *immacula* Walk., *ibid.*, 50; *nigrimacula*

Walk., *ibid.*, 63; *sobria* Walk., *ibid.*, 63.

Cephalowys terpsichore Walk., *ibid.*, 239.

Fidicina confinis Walk., J. Linn. Soc., Zool. (1867) 10, 92.

Dundubia mannifera Stål, Berl. Ent. Ztschr. (1866) 10, 170; Ö. V. A. F.

(1870) 707; Dist., Mono. Orient. Cicadid. (1892) 39, pl. 4, fig. 10,

a, b; Fauna British Ind., Rhyn. (1906) 3, 94, fig. 44.

Mogannia terpsichore Atkins., J. A. S. B. (1885) 53, 233.

This species is found over the entire East, as far north as China. It has been taken in Mindanao (6687, 7299 Mrs. M. S. Clemens) and on Sibuyan Island (2010 R. C. McGregor).

PALAWAN, Iwahig and Tara Island, P. I. (10893 W. *Schultze*, and 11722, 11972, 11978 C. M. Weber), 16 specimens.

COSMOPSALTRIA Stål.

Hem. Afr. (1866) 4, 5.

Type: *C. doryca* Boisd.

5. COSMOPSALTRIA INERMIS Stål.

Cosmopsaltria inermis Stål, Ö. V. A. F. (1870) 708; Dist., Mono. Orient.

Cicadid. (1892) 49, pl. 6, fig. 15, a, b.

This quite rare insect is very well figured by Distant. It has not been brought previously to this laboratory by any collector. Mr. Schultze was fortunate in securing a ♂ and a ♀ specimen.

PALAWAN, Iwahig, P. I. (10892 W. *Schultze*), 2 specimens.

Subf. GÆANINÆ.

Div. MOGANNIARIA.

MOGANNIA Amyot et Serville.

Hist. des Hém. (1843) 467.Type: *Mogannia conica* Germ.

6. MOGANNIA CONICA Germ.

Cicada conica Germ., Thon's Arch. (1830) 2, pt. 2, 39.*Mogannia illustrata* Amy. et Serv., Hém. (1843) 467, pl. 9, fig. 4.*Cephalows hemelytra* Sign., Ann. Soc. Ent. Fr. (1847) (2) 5, 295.*Mogannia indicans, ignifera et avicula* Walk., List Hom. (1850) 1, 249, 250; (1852) 4, pl. 2, fig. 5.*Mogannia recta* Walk., List Hom., Suppl. (1858) 39.*Mogannia conica* Stål, Ö. V. A. F. (1862) 483; Dist., Mono. Orient. Cicad. (1892) 122, pl. 14, fig. 18, a, b, Fauna British Ind., Rhyn. (1906) 3, 152.*Mogannia histrionica* Uhler, Proc. Acad. Nat. Sci. Philadelphia (1862), 283.*Mogannia venutissima* Stål, Ö. V. A. F. (1865) 154.

PALAWAN, Bacuit, P. I. (11654 *C. M. Weber*), 1 specimen, which is the typical form. There is much variation in this species according to Distant *et al.*, although all the Philippine specimens appear to conform to the description of the typical form.

Subf. TIBICININÆ.

Div. HUECHYSARIA.

HUECHYS Amyot et Serville.

Hist. des Hém. (1843) 464.Type: *H. sanguinea* De Geer.

7. HUECHYS SANGUINEA De Geer.

Cicada sanguinea De Geer, Mém. (1773) 3, 221, pl. 33, fig. 17.*Tettigonia sanguinolenta* Fabr., Syst. Ent. (1775) 681; Stoll, Pun. et Cig. (1788-1790) fig. 62; Fabr., Syst. Rhyng. (1803) 42.*Cicada sanguinolenta* Oliv., Enc. Méth. (1790) 5, 756.*Huechys sanguinea* Amy. et Serv., Hist. des Hém. (1843) 465; Dist., Mono. Orient. Cicadid. (1892) 111, 112, Fauna British Ind., Rhyn. (1906) 3, 157, fig. 69.

There is considerable variation in the color and markings of this species, but as all grades may often be seen in individuals of the same community, these should hardly be considered as even of varietal value. The insects lose their color in alcohol, the red changing to golden yellow, so that such specimens might even be considered as distinct species.

PALAWAN, Iwahig, P. I. (10955 *W. Schultze* and 11707 *C. M. Weber*), 140 specimens in many of which the mesonotum is nearly completely suffused with red.

Fam. FULGORIDÆ.

Subf. FULGORINÆ.

Div. APHANARIA.

APHÆNA¹ Guérin.

Voy. Bélang. Ind. Orient., Zool. (1834) 451.

Type: *A. farinosa* Weber.

8. APHÆNA FARINOSA Weber.²

Cicada farinosa Weber, *Obs. Ent.* (1801) 114.

Lystra farinosa Fabr., *Syst. Rhyng.* (1803) 57; *Germ., Thon's Ent. Arch.* (1830) pt. 2, 52.

Aphana farinosa Burm., *Handb. der Ent.* (1835) 2, pt. 1, 166; Stål, *Stett. Ent. Zeit.* (1863) 24, 232, Ö. V. A. F. (1870) 742; Atkins, *J. A. S. B.* (1885) 54, 142; Distant, *Fauna British Ind., Rhyng.* (1906) 3, 201.

Aphana farinosa Spin., *Ann. Soc. Ent. Fr.* (1839) 8, 244; Walk., *List Hom.* (1851) 2, 274.

Aphana scutellaris White, *Ann. Mag. Nat. Hist.* (1846) 17, 330; Westw., *Cab. Orient. Ent.* (1848) 73, *pl. 36, fig. 3.*

Aphaena saundersii Walk., *tom. cit.* 277.

This species, known in India, Malay Peninsula, Java, Borneo and Sumatra, has been previously reported from the Philippines by Stål.

PALAWAN, Iwahig, P. I. (10957 *W. Schultze*), 2 specimens, which having been put into alcohol, show no white tomentum.

SCAMANDRA Stål.

Stett. Ent. Zeit. (1863) 24, 232.

Type: *S. rosea* Guér.

9. SCAMANDRA HERMIONE Stål.

Scamandra hermione Stål, *Ann. Soc. Ent. Fr.* (1864) (4) 4, 62, Ö. V. A. F. (1870) 743.

The specimen in my possession has a somewhat greater alar expanse than that designated by Stål for his type, it being 67 millimeters across. It is slightly longer also, its length being 21.5 mm.

PALAWAN, Iwahig, P. I. (10954 *W. Schultze*). A single specimen, agreeing perfectly with the description except as to size.

¹ According to the rules of priority there is no doubt that Guérin's name should stand as he originally wrote it. There appears no special warrant for the change by Burmeister and much less for the following of his lead by modern entomologists. Spinola, in 1839, reverted to Guérin's name, with reason.

² Weber *not* Fabricius.

Subf. DICTYOPHARINÆ.

DICTYOPHORA Germar.

Silb. Rev. Ent. (1883) 1, 175.

Type: *D. europæa* Linn.

10. DICTYOPHORA PALLIDA Don.

Fulgora pallida Don., Ins. Ind. (1800) 8, fig. 2.

Fulgora graminea Fabr., Syst. Rhyng. (1803) 4.

Flatta lyrata Germ., Thon's Ent. Arch. (1830) (2) 2, 47.

Pseudophana lyrata Burm., Handb. Ent. (1835) 2, 160

Pseudophana pallida Westw., Tr. Linn. Soc. (1841) 18, 150.

Dictyophora despecta Walk., List Hom. (1851) 2, 314; Atkins, J. A. S. B. (1886) 55, 27.

Dictyophora albivitta Walk., loc. cit. 319; Melich., Hom. Fauna Ceyl. (1903) 22.

Dictyophora lepthorina Walk., loc. cit. 321; Atkins, loc. cit. 30.

Dictyophora pallida Atkins, loc. cit. 27; Dist., Fauna British Ind., Rhyn. (1906) 3, 243.

Dictyophora ?albivitta Atkins, loc. cit. 29.

Dictyophora percarinata Kirby, J. Linn. Soc., Zool. (1891) 24, 134; Melich., loc. cit. 24.

Dictyophora hastata Melich., ibid. 25.

Kirkaldy³ in his description of insects affecting sugar cane indicates an entirely different position and name for the insect described by Distant as cited above, and doubts the identity of *Fulgora pallida* Don., with the species above indicated.

There is certainly nothing in the essential structure of the insect under my hand which would ally it with *Zamila aberrans* Kirby. On the contrary, while Distant's figure of *Dictyophara* [sic] *lineata* Don., is extremely poor as to neurulation of the tegmina, my specimen conforms closely to the figure of *Pibrocha egregia* Kirby, of a closely related genus, as given both by Kirby⁴ and Distant.⁵

As to the term *Dictyophara*, I find the citation for Germar's genus in Agassiz's Nomenclator Zoologicus as *Dictyophora*. I have not Germar's original, but Kirkaldy states that Germar gave it *Dictyophora*,⁶ and as Stål⁷ gave it *Dictyophora*, I imagine that this change to *Dictyophara* is a typographical error which has been transmitted. Distant in his citations gives *Dictyophara percarinata* Kirby, whereas Kirby in his original description gives *Dictyophora percarinata*. I see no reason why the name should have been changed and agree with Kirkaldy's statement cited.

PALAWAN, Iwahig and Bacuit, P. I. (10973 W. *Schultze* and 11663

³ *Ann. Soc. Ent. Belg.* (1907), 51, 123.

⁴ Kirby, *J. Linn. Soc. Zool.* (1891), 24, pl. 5, fig. 4.

⁵ Distant, *Fauna British Ind., Rhyn.* (1906), 3, 240, fig. 104.

⁶ Kirkaldy, loc. cit. p. 124, footnote.

⁷ Stål, *Hem. Fabr.* (1869), 2, 91.

C. M. Weber). A single specimen of this insect was taken at each place. It is common in other parts of the Islands, but has not been reported previously.

CENTROMERIA Stål.

Ö. V. A. F. (1870) 745.

Type: *C. longipennis* Walk.

11. **CENTROMERIA LONGIPENNIS** Walk.

Centromeria longipennis Walk., List Hom. (1851) 2, 316; Stål, Ö. V.

A. F. (1870) 745; Dist., Fauna British Ind., Rhyn. (1906) 3, 250, ref.

This species was originally described from the Philippines.

PALAWAN, Bintuan and Tara Island, P. I. (11691, 11712 *C. M. Weber*), 4 specimens, the single one from Tara Island somewhat mutilated and discolored.

Subf. **ACHILINÆ**.

FAVENTIA Stål.

Hem. Afr. (1866) 4, 181.

Type: *F. pustulata* Walk.

12. **FAVENTIA PUSTULATA** Walk.

Cixius pustulatus Walk., J. Linn. Soc., Zool. (1856) 1, 87.

Faventia pustulata Stål, Berl. Ent. Ztschr. (1866) 10, 392; Dist., Fauna British Ind., Rhyn. (1906) 3, 287, fig. 135.

This species has not been recorded hitherto from the Philippines. It is known from Tenasserim and Singapore.

PALAWAN, Iwahig, P. I. (10977 *W. Schultze*). A single specimen.

Subf. **DERBINÆ**.

PHENICE Westwood.

Tr. Linn. Soc. (1845) 19, 10.

Type: *P. fritillaris* Westw.

13. **PHENICE MOESTA** Westw.

Derbe moesta Westw., Ann. Mag. Nat. Hist. (1851) (2) 7, 209.

Phenice moesta Stål, Ö. V. A. F. (1870) 750; Atkins., J. A. S. B. (1886)

55, 41; Melich., Hom. Fauna Ceyl. (1903) 54, pl. 2, fig. 11.

Assamia dentata Buckt., Ind. Mus. Notes (1896) 4, 1.

This insect is rather common on sugar cane in the Philippines at certain seasons of the year. It might eventually prove to be a serious pest.

PALAWAN, Iwahig, P. I. (10952 *W. Schultze*), 2 specimens.

JADA Distant.

Fauna British Ind., Rhyn. (1906) 3, 299.

Type: *J. nitagalensis* Dist.

14. **Jada maculipennis** sp. nov. (Plate III, fig. 8.)

Fuliginous, facial carinæ slightly ferruginous; clypeus and rostrum sanguineous; second antennal segment yellowish, passing lower margin of eye; prothorax

obscure brown-ochraceous; mesonotum glabrous medially; abdomen dull ochraceous dorsally and ventrally, segments with brown margins; genitalia slightly sanguineous.

Tegmina fuliginous, veins brown, except apical which are spotted with sanguineous; entire costal margin with pale ochraceous spots more or less confluent basally; a spot at angle of ultimate and penultimate branches of upper longitudinal vein;⁸ two or three subcostal, subapical spots on costal vein and three pale spots on apex, the upper and lower with a brown point in its margin. Hind wings uniformly fuliginous with brown veins.

Length 3.5 millimeters, length of tegmina 9.5 millimeters.

PALAWAN, Tara Island, P. I. (*C. M. Weber* collector).

Type ♂ No. 11711 in Entomological Collection, Bureau of Science, Manila, P. I. A single specimen.

This species resembles *J. nitagalensis* Dist., in general pattern, but the wing maculation is quite different and the ♂ genitalia are not so markedly hooked as in Distant's species. The right hind wing of the type is mutilated, the left one has been removed from the specimen and mounted on a card attached to the same pin.

ZORAIDA Kirkaldy.

Entomologist (1900) 242 (*nom. nov.*)

Type: *Z. sinuosa* Westw.

15. ZORAIDA JAVANICA Westw.

Thracia javanica Westw., Tr. Linn. Soc. (1842) 19, 19, pl. 2, fig. 9;
Walk., List Hom. (1851) 2, 400; Stål, Ö. V. A. F. (1870) 750.

This species is a true *Zorida*. It has been taken at Montalban Gorge near Manila, but is not abundant.

PALAWAN, Iwahig, P. I. (12044 *C. M. Weber*). A single specimen, somewhat damaged.

Subf. LOPHOPINÆ.

SERIDA Walker.

J. Linn. Soc., Zool. (1857) 1, 158.

Type: *S. latens* Walk.

16. SERIDA LATENS Walk.

Serida latens Walk., J. Linn. Soc., Zool. (1857) 1, 158.

Lerida fervens id., loc. cit. pl. 7, fig. 8.²

Serida fervens Dist., Fauna British Ind., Rbyn. (1906) 3, 325, fig. 160.

PALAWAN, Iwahig, P. I. (11900 *C. M. Weber*), 2 specimens.

The specimens from the Philippines agree with the description and figure in every particular, except that the markings are slightly paler and the tibiæ are somewhat ampliate, not prominently so, while Distant's figure shows absolutely no ampliation.

⁸ As indicated in Distant's description.

² Figured as *Lerida fervens* by Walker, probably in error or as an error of the artist.

ZAMILA Walker.

Journ. Ent. (1862) 1, 304.

Type: *Z. lycoides* Walk.

17. ZAMILA PERPUSILLA Walk.

Pyrops perpusilla Walk., List Hom. (1851) 2, 269.

Zamila perpusilla Dist., Fauna British Ind., Rhyn. (1906) 3, 327.

PALAWAN, Iwahig, P. I. (10978 W. *Schultze*). A single specimen, which lacks the abdomen.

Originally described from India, this is the first record of this species for the Philippines.

JIVATMA Distant.

Fauna British Ind., Rhyn. (1906) 3, 328.

Type: *J. metallica* Dist.

18. *Jivatma triangulata* sp. nov. (Plate III, fig. 5.)

Vertex, face and clypeus pale ochraceous, the face apically, transversely white, the clypeus with oblique, brown hair-lines and black apex; pronotum slightly darker; mesonotum brown between lateral carinae and in lateral angles; all carinae and margins slightly paler. Antennae white, base of third segment beneath with a black spot.

Abdominal segments dorsally dark brown with cretaceous exudate at segmental articulations.

Tegmina brown, very dark in claval areas and with a triangular, hyaline area on middle of costa, its apex reaching disc of tegmen. Costal margin pale hyaline before and after triangular area with a series of about seven oblique brown lines crossing it and coalescing with brown of tegmen; beginning at proximal end of triangular area and extending to apex of the tegmen, a continuation of this series, consisting of about nine other brown, oblique lines, the first two short, the next five twice as long, the next or eighth a brown curved-sided triangle and the ninth like the 3-7. In the posterior apical angle a small dark brown spot, preceded anteriorly by a hyaline streak. Veins on the apical third pale brown. Wings fuliginous, veins black. Ventral surface ochraceous, more or less suffused with cretaceous; legs ochraceous, anterior femora with three pale brown annulations, anterior and mid tarsi with three, the apical being nearly black; spines of posterior tibiae broadly black at their bases and with black tips; first tarsal segment more than twice length and breadth of remaining. Rostrum extends to posterior coxae.

Length 6 millimeters. Length of tegmen 8.5 millimeters.

PALAWAN, Bintuan, P. I. (*C. M. Weber* collector).

Cotypes No. 11679 in Entomological Collection, Bureau of Science, Manila, P. I. Described from two specimens.

Subf. ISSINÆ.

HEMISPHERIUS Schaum.

Ersch & Gruber's Allg. Enc. Wiss. Künste (1850) 1, 71.

Type: *H. coccinelloides* Burm.

19. *Hemispærius parenthesis* sp. nov. (Plate III, fig. 3.)

Obovoidal, pale ochraceous with dark brown, transverse markings on the tegmina; head ochraceous, the margins diffusely sanguineous; eyes brown; ocelli rufous; clypeus pitchy brown, except basal portion which is ochraceous; pronotum

concolorous with head and similarly margined; propleura black, as is also a broad band on anterior and mid coxæ; scutellum concolorous with head but not red-margined; tegmina convex, costal margin decidedly convex; the entire disc to claval and sutural margins, but excepting the costal and apical marginal areas which are ochraceous, dark chestnut brown with two transverse curved fasciæ, one anteriorly arched, across the middle of the tegmen, the other parenthesis-shaped on the apical third; these fasciæ do not attain the margins of the brown area on either side. The extreme external margin of the tegmen is slightly reflexed and is dark brown. Wings minute, translucent, brown apically, with yellow veins, pale basally.

Legs dark ochraceous; anterior and mid tibiæ with two brown annulations; those of the latter, which is externally sulcate, are not complete; apical spines to posterior tibiæ black, as is the single spine on apical third.

Basal ventral, abdominal segments dark brown, their margins ochraceous, apical segments dark ochraceous. Genitalia ochraceous; black apically.

Length, including tegmina, 3.7 millimeters, width 2.75 millimeters.

PALAWAN, Tara Island, P. I. (*C. M. Weber* collector).

Type ♀ No. 11720 in Entomological Collection, Bureau of Science, Manila, P. I.

Three other specimens, two from the same locality and one from Bintuan, P. I. (11697 *C. M. Weber*), labeled paratypes, are somewhat paler in color with the ochraceous color of the tegmina more diffuse. The specimen No. 11697 has the facial disc brown, its margins ochraceous and mid coxæ somewhat broader.

20. *Hemisphærius transfasciatus* sp. nov. (Plate III, fig. 4.)

Obovoidal, pale brown, with three transverse yellow lines on tegmina.

Head, pronotum and scutellum pale ochraceous, all margined with ferruginous; face slightly darker on disc; clypeus and rostrum black, glabrous; former pale yellow basally. Tegmina pale brown with a transverse basal interrupted yellow fascia, another, sinuate, on basal third from near internal suture externad for two-thirds width of tegmen, and a third, crescentic, across apical third not attaining either margin; wings fuliginous apically, with white veins, yellow basally.

Abdominal segments dorsally, ochraceous, narrowly red-margined, ventrally obsolescently brown, widely yellow-margined; genitalia brown.

Legs ochraceous, apices of anterior and mid femora and two annulations on anterior and mid tibiæ dark brown, posterior tibiæ dark ochraceous; tibial spine on apical third not conspicuous, black, as are the apical and subapical.

Length 3.75 millimeters, width 2.75 millimeters.

PALAWAN, Iwahig, P. I. (*W. Schultze* collector).

Type ♂ No. 11961 in Entomological Collection, Bureau of Science, Manila, P. I. Described from a single specimen.

While this species might be taken for the ♂ of *H. parenthesis* at first sight, the pleural and coxal markings together with the entirely

different pattern of the tegminal markings will at once aid in differentiating it.

21. *Hemisphærius trimaculatus* sp. nov. (Plate III, fig. 1.)

Obovoidal, brown, with ochraceous spots on tegmina. Occiput dark ochraceous, face brown except at union with clypeus, where it is pale ochraceous; clypeus and rostrum black, glabrous, base pale ochraceous, medially prominent; eyes brown, narrowly pale-margined; pronotum pale yellow, red-margined; scutellum brown, margins rufous; pleuræ pale yellow with a longitudinal dark brown stripe on pro- and mesopleuræ; anterior and mid coxæ pale yellow, each with a broad, black median band. Tegmina brown, pale-margined and with three irregular, pale, ochraceous spots, one on basal third and two across apical third; wings black, the veins and basal areas yellow. Abdominal segments dorsally brown with sanguineous margins, ventrally with yellow margins. Genitalia yellow, brown at apices of lobes. Legs ochraceous; fore and mid tibiæ with two brown annulations, the subbasal obsolescent. Posterior tibiæ apically black, with a subapical black-tipped spine and another on apical third.

Length 3.75 millimeters, width 2.75 millimeters.

PALAWAN, Iwahig, P. I. (*W. Schultze* collector).

Type ♀ No. 10962 in Entomological Collection, Bureau of Science, Manila, P. I. Described from a single specimen.

22. *Hemisphærius stáli* sp. nov. (Plate III, fig. 2.)

Obovoid, ochraceous and red, with three longitudinal red lines on face, and basal half of tegmina brown.

Head deep yellow; face margined with vermilion and with a broad, median, vermilion, longitudinal line which, together with marginal red, terminates at base of clypeus which is uniformly yellow except apical half and rostrum which are pitchy black. Occiput yellow, red-margined; eyes brown with paler margins. Pronotum lens-shaped, the anterior margin slightly more convex than the posterior and both with vermilion margins; scutellum equilateral, yellow, with vermilion margins of which the lateral are quite narrow and a median vermilion fascia from anterior margin halfway to apex. Tegmina ochraceous, basal half dark, pitchy brown except tumeral angles which are paler and internal sutures which are broadly yellow, margined with red to apex of claval region. Wings exceedingly small, not measuring a millimeter in length, and of a pale ocher.

Abdominal segments dorsally ochraceous, obsoletely red-margined, ventrally brown with pale ochraceous margins.

Legs ochraceous; apices of tibiæ black. Apices of tarsi brown. Posterior tibial spines black-tipped.

Length 4.5 millimeters; width 3.4 millimeters.

PALAWAN, Mount Kapuas, P. I. (*C. M. Weber* collector).

Type No. 12399 in Entomological Collection, Bureau of Science, Manila, P. I. Described from a single specimen in perfect condition.

Somewhat like *H. reticulatus* Dist., in general pattern, but differing decidedly in color and facial marking.

Dedicated to the memory of Dr. Carolus Stål.

Subf. RICANIINÆ.

Div. RICANIINARIA.

POCHAZIA Amyot et Serville.

Hist. des Hémi. (1843) 528.Type: *P. fasciata* Fabr.

23. POCMAZIA GUTTIFERA Walk.

Pochazia guttifer Walk., List. Hom. (1851) 2, 427; Melich., Ann. Hoffm. Wien. (1898) 13, 216, pl. 9, fig. 22, Hom. Fauna Ceyl. (1903) 83; Dist., Fauna British Ind., Rhyn. (1906) 3, 374.

Ricania guttifer Stål, Ö. V. A. F. (1862) 491; Atkins., J. A. S. B. (1886) 55, 57.

This species, described by Walker from Silhet, and known also in Darjiling and Tenasserim, has not been reported before from the Philippines.

PALAWAN, Iwahig, P. I. (10972 *W. Schultze*). A single somewhat dilapidated specimen was taken.

RICANIA Germar.

Mag. Ent. (1818) 3, 221.Type: *R. fenestrata* Fabr.

24. RICANIA SPECULUM Walk.

Platoides speculum Walk., List. Hom. (1851) 2, 406.

Platoides tenebrosus et perforatus, Ibid., pp. 406 and 407.

Ricania malaya, Stål, Ö. V. A. F. (1854) 247.

Ricania speculum Stål, loc. cit. (1870) 765; Atkins., J. A. S. B. (1886) 55, 54; Melich., (part) Ann. Hoffm. Wien. (1898) 13; 223; Dist., Fauna British Ind., Rhyn. (1906) 3, 377.

A well-known species in the Philippines. There is a slight variation in the piceous markings of the apical clear spots and of the costal spots as to coalition.

PALAWAN, Bacuit, P. I. (11673 *C. M. Weber*), 3 specimens.

25. RICANIA SUBSINUATA Stål.

Ricania subsinuata Stål, Ö. V. A. F. (1870) 768.

PALAWAN, Iwahig, P. I. (10965 *W. Schultze*), 2 specimens.

This species has two costal transparent spots, another at the apical angle and two on the apical margin, but it also has what Stål calls "albido-hyaline" spots or areas over the whole tegmen, or "corium" as he demonstrates it, in his description, *q. v.*

26. RICANIA TÆNIATA Stål.

Ricania tæniata Stål, Ö. V. A. F. (1870) 766.

PALAWAN, Iwahig, P. I. (10971 *W. Schultze* and 11982 *C. M. Weber*), 4 specimens. This species is easily distinguishable by the broad, medial,

dark band on the tegmina and the absence of the spot at the exterior apical angle.

27. *RICANIA FUMOSA* Walk.

Flatoides fumosus Walk., List. Hom. (1851) 2, 414.

Ricania proxima Melich., Ann. Hoffm. Wien. (1898) 13, 226, pl. 11, fig. 22.

Ricania fumosa Stål, Ö. V. A. F. (1862) 491; Atkins., J. A. S. B. (1886) 55, 55; Melich., loc. cit. p. 230; Dist., Fauna British Ind., Rhyn. (1906) 3, 382.

This species has been collected in Sumatra, Siam, Assam, Java, and Celebes, but has not been recorded previously from the Philippines.

PALAWAN, Iwahig, P. I. (10970 *W. Schultze*), 7 specimens. The chief point of difference between this species and *R. tæniata* is that the apex of the tegmen in *tæniata* is more acute than in *fumosa*.

Subf. FLATINÆ.

Div. CERYNIARIA.

CERYNIA Stål.

Rio Jan. Hem. (1862) 2, 68.

Type: *C. albata* Stål.

28. *CERYNIA MARIA* White.

Peciloptera maria White, Ann. Mag. Nat. Hist. (1846) 18, 25, pl. 1, fig. 3.

Flatta maria Walk., List. Hom. (1851) 2, 436.

Flatta completa Ibid. p. 436.

Flatta tenella Ibid. p. 437.

Cerynia lutescens Melich., Ann. Hoffm. Wien. (1901) 16, 220.

Cerynia maria Stål, Ö. V. A. F. (1862) 490; Dist., J. A. S. B. (1879) 48, 38, Ann. Mag. Nat. Hist. (1883) (5) 11, 172; Atkins., J. A. S. B. (1886) 55, 64; Dist., Fauna British Ind., Rhyn. (1906) 3, 408, fig. 210.

This beautiful insect has never before been recorded from the Philippines. It was described by White from Silhet, India, and it has been taken outside of India only in west China and Sumatra (*fide Melichar*). The Philippine specimens have the subbasal spot on the tegmina more luteo-chraceous.

PALAWAN, Iwahig, P. I. (10980 *W. Schultze*), 2 specimens.

SALURNIS Stål.

Ö. V. A. F. (1870) 773.

Type: *S. granulosa* Stål.

29. *SALURNIS GRANULOSA* Stål.

Salurnis granulosa Stål, Ö. V. A. F. (1870) 774.

This species, the type of the genus, was originally described from the Philippine Islands. Since the time of its first description it has apparently not been taken previous to the present record. A species

somewhat similar was taken in Manila in 1905, but I have, as yet, not placed it positively. This second species was identified by Distant as *S. granulosa*, but certainly does not conform with Stål's description, either generically or specifically.

PALAWAN, Iwahig, P. I. (10979 *W. Schultze*). A single well-marked specimen.

NEPHESA Amyot et Serville.

Hist. des Hém. (1843) 527.

Type: *N. rosea* Spin.

30. **NEPHESA ROSEA** Spin.

Ricania rosea Spin., *Ann. Soc. Ent. Fr.* (1839) 8, 400.

Nephesa rosea Amy. et Serv., *Hist. des Hém.* (1843) 528; Walk., *List Hom.* (1851) 2, 433; Stål, *Ö V. A. F.* (1870) 773.

PALAWAN, Iwahig, P. I. (10981 *W. Schultze*), 33 specimens. There is considerable variation in this species as to color, the tints ranging from pale green through yellow and white to rose. Some of the green specimens have the tegmina bordered with yellow-orange. Found by Schultze on cacao (*Theobroma cacao* Linn.).

DÆDA gen. nov.

Type: *Dæda puncticlava* sp. nov.

Head, including eyes, somewhat narrower than pronotum; vertex one-third as long as its width, anterior margin (viewed from dorsad) straight, obtusely angulate medially, laterally carinate and slightly laminate before eyes; ocelli widely separate, their distance from eyes one-fifth their interspace. Face confluent with vertex, as broad as long, lateral margins convex and carinate apically; submedian area broadly foveate before clypeus; median carination strongly tumescent ventrad to juncture of face and vertex, less elevate toward clypeus, which is separated from face by profound transverse sulcus; rostrum just passes mid coxæ.

Pronotum slightly longer than head, its anterior margin convex and in line with middle of eyes, its posterior margin evenly concave. Mesonotum three times length of pronotum, its disc evenly convex and medially *sulcate*, its posterior-medial angle tumescent-tuberculate.

Tegmina twice as long as wide, costal margin arched at base; costal area twice width of radial and with parallel and reticulated oblique veins and sparse granulations. Radial area with cross-veins on posterior third. Outer half of disc with reticulated parallel veins, apical area beyond transverse line with most of veins furcate; entire clavus, interiad to its exterior vein, strongly granulate, the granulations disposed in parallel lines. Posterior tibiæ with two subapical spines.

Most closely resembles *Ketumala* Dist., from which, however, it differs in the shape of the tegmina, the tumescent facial carination, the number of spines on the posterior tibiæ and the position of the transverse preapical tegminal line.

It differs from all other related genera in the presence of the mesonotal sulcation.

31. *Dæda puncticlava* sp. nov. (Plate III, fig. 6.)

Compactly ovate, the tegmina compressed so that their apical margins are vertical; dark ochraceous, the posterior apical region of the tegmina fuscous.

Head, pro- and mesonota pale ochraceous, glabrous, eyes brown, ocelli vitreous; clypeus sparsely pubescent; tegmina olivaceo-fuscous apically, pale ochraceous basally; clavus with an oval, black foveate puncture at apical third between longitudinal veins. Legs pale ochraceous.

Length 4 millimeters, including tegmina 7 millimeters; length of tegmen 6 millimeters.

PALAWAN, Tara Island, P. I. (*C. M. Weber* collector).

Type No. 11719 in Entomological Collection, Bureau of Science, Manila, P. I. Described from a single specimen.

Div. FLATOIDESARIA.

UXANTIS Stål.

ö. V. A. F. (1870) 775.

Type: *U. consputa* Stål.

32. *UXANTIS SICCIFOLIA* Stål.

Uxantis siccifolia Stål, ö. V. A. F. (1870) 776.

This species, of which Stål possessed only the ♂, is fairly common in Manila. It may usually be taken on *Casuarina equisetifolia* Forst.

PALAWAN, Bacuit, P. I. (11672 *C. M. Weber*), 1 specimen.

Fam. MEMBRACIDÆ.

Subf. CENTROTINÆ.

Div. MICREUNARIA.

LEPTOBELUS Stål.

Hem. Afr. (1866) 4, 86.

Type: *L. dama* Germ.

33. *LEPTOBELUS DAMA* Germ.

Centrotus dama Germ., Silb. Rev. Ent. (1835) 3, 258; Fairm., Ann. Soc.

Ent. Fr. (1846) 4, 510, pl. 3, fig. 14.

Leptobelus dama Stål, Berl. Ent. Ztschr. (1866) 27, 386; Atkins.,

J. A. S. B. (1885) 54, 81; Dist., Fauna British Ind., Rhyn. (1908)

4, 15, fig. 11.

This is the first record of this species from the Philippine Islands.

PALAWAN, Tara Island, P. I. (11715 *C. M. Weber*), 2 specimens, one having the corneous processes broken.

Div. LEPTOCENTRARIA.

LEPTOCENTRUS Stål.

Hem. Afr. (1866) 4, 87 and 90.

Type: *L. bos* Sign.

34. LEPTOCENTRUS TAURUS Fabr.

Membracis taurus Fabr., Syst. Ent. (1775) 676; Oliv., Enc. Méth. (1792) 665.

Membracis rupicapra Fabr., Ent. Syst. Suppl. (1798) 514.

Centrotus rupicapra Id., Syst. Rhyng. (1803) 18.

Centrotus taurus Ibid., p. 20.

Membracis tricornis Hardw., Zool. Journ. (1828) 4, 114, Suppl. pl. 30, figs. c, d, f.

Centrotus terminalis Walk., List. Hom. (1851) 2, 604; Stål, Ö. V. A. F. (1862) 491; Melich., Hom. Fauna Ceyl. (1903) 109.

Centrotus vicarius Walk., loc. cit., p. 605.

Leptocentrus taurus Stål, Hem. Fabr. (1869) 2, 50; Atkins., J. A. S. B. (1885) 54, 85; Dist., Fauna British Ind., Rhyn. (1908) 4, 28, fig. 24.

Leptocentrus gazella Buckt., Mono. Membrac. (1903) 235, pl. 53, fig. 5a.

I am inclined to believe that the species heretofore called *L. reponens* Walk. and *L. antilope* Stål are the same as the above, the only difference indicated by Distant being a slightly greater anterior foliation of the transverse processes of the pronotum.

PALAWAN, Bacuit, Bintuan, and Iwahig, P. I. (11669, 11690, 11924 *C. M. Weber*), 5 specimens.

Div. GARGARARIA.

GARGARA Amyot et Serville.

Hist. des Hém. (1843) 537.

Type: *G. genistæ* Fabr.

53. GARGARA PYGMÆA Walk.

Centrotus pygmaeus Walk., List Hom. (1851) 2, 630.

This minute species, described originally from the Philippines and, apparently, not noted since its description, may be distinguished from its allies by the albescent apices of the tegmina.

PALAWAN, Bacuit and Iwahig, P. I. (11668, 11925 *C. M. Weber*), 3 specimens.

Fam. CERCOPIDÆ.

Subf. MACHÆROTINÆ.

MACHÆROTA Burmeister.

Handb. der Ent. (1835) 2, pt. 1, 128.

Type: *M. ensifera* Burm.

36. MACHÆROTA ENSIFERA Burm.

Machærota ensifera Burm., *Handb. der Ent.* (1835) 2, pt. 1, 128; Stål, Ö. V. A. F. (1870) 727; Sign., *Ann. Soc. Ent. Fr.*, Bull. (1879) (5) 9, xlviii; Atkins., J. A. S. B. (1885) 54, 22; Dist., *Fauna British Ind.*, Rhyn. (1908) 4, 80, fig. 65.

An abundant species in the Philippines. It builds its calcareous, tube-like nests on shrubs of *Sida acuta* Burm., and all the stages of its development may be easily observed.

PALAWAN, Iwahig, P. I. (11928 C. M. Weber). A single specimen.

Subf. APHROPHORINÆ.

CLOVIA Stål.

Hem. Afr. (1866) 4, 75.

Type: *C. bigoti* Sign.

37. CLOVIA CONFIFER Walk.

Ptyelus confifer Walk., *List Hom.* (1851) 3, 711.

Ptyelus simulans Ibid. p. 717.

Ptyelus frenulatus Stål, Ö. V. A. F. (1854) 250; Freg. Eug. Resa, Ins. (1859) 286, Ö. V. A. F. (1862) 493.

Clovia frenulata Stål, loc. cit. (1870) 726.

Clovia confifer Atkins., J. A. S. B. (1885) 54, 114; Dist., *Fauna British Ind.*, Rhyn. (1904) 4, 93, fig. 72.

This species, though reported previously from the Philippines, has not, up to this time, appeared in our collection.

PALAWAN, Iwahig, P. I. (10964 W. Schultze and 11930 C. M. Weber), 2 specimens.

MANDESA Distant.

Fauna British Ind., Rhyn. (1908) 4, 106.

Type: *M. amplificata* Dist.

38. MANDESA VITTIFRONS Stål. (Plate III, fig. 7 ♂.)

Clovia vittifrons Stål, Ö. V. A. F. (1870) 725.

In this species, which is undoubtedly referable to this genus, the discal transverse raised ridge mentioned by Distant in his generic diagnosis crosses only the inner two-thirds of the tegmina but the other characters are not to be mistaken. The ♀ is considerably larger than the ♂ and is more pallid with all dark markings less pronounced.

In the specimens before me the measurements are as follows: ♂ length

7 millimeters, width at widest portion of tegmina 3.25 millimeters, ♀ length 8.25–9.25 millimeters, width 3.75 millimeters.

Thus far known only from the Philippines.

PALAWAN, Iwahig, P. I. (10963 *W. Schultze* and 11981 *C. M. Weber*); Tara Island (11713 *C. M. Weber*), 5 specimens.

Subf. CERCOPINÆ.

COSMOSCARTA Stål.

Hem. Fabr. (1869) 2, 11.

Type: *C. heros* Fabr.

39. COSMOSCARTA INCLUSA Walk.

Cercopis inclusa Walk., List Hom. (1851) 3, 658; Stål, Ö. V. A. F. (1865) 147.

Cosmoscarta inclusa Butl., Cist. Ent. (1874) 1, 265; Melich., Hom. Fauna Ceyl. (1903) 125. pl. 4, fig. 5; Dist., Fauna British Ind., Rhyn. (1908) 4, 140.

This species, originally described from Ceylon and not thus far reported from any other locality, is here recorded from the Philippines for the first time.

PALAWAN, Iwahig, P. I. (11973 *C. M. Weber*), 2 specimens.

Fam. JASSIDÆ.

Subf. LEDRINÆ.

PETALOCEPHALA Stål.

Ö. V. A. F. (1853) 266.

Type: *P. bohemani* Stål.

40. PETALOCEPHALA PHILIPPINA Stål.

Petaloccephala philippina Stål, Ö. V. A. F. (1870) 732.

PALAWAN, Iwahig, P. I. (10982 *W. Schultze*), 1 specimen.

Subf. TETTIGONIELLINÆ.

TETTIGONIELLA Jacobi.

Zool. Jahrb. Syst. (1904) 19, 778 (nom. nov.)

Type: *T. viridis* Linn.

41. TETTIGONIELLA IMPUDICA Sign.

Tettigonia impudica Sign., Ann. Soc. Ent. Fr. (1853) (3) 1, 677.

Tettigonia impudica? Stål, Ö. V. A. F. (1870) 733.

This species was originally described from the Philippines in Signoret's monograph.

PALAWAN, Iwahig and Tara Island, P. I. (10974 *W. Schultze*, 11714 *C. M. Weber*), 5 specimens.

KOLLA Distant.

Fauna British Ind., Rhyn. (1908) 4, 223.

Type: *K. insignis* Dist.

42. **Kolla tripunctifrons** sp. nov.

Head and pronotum more or less pale ochraceous; tegmina albescent, semi-opaque, apical veins fuscous. Two black spots on anterior margin and another before middle of vertex. Eyes black. Ventral surface of body slightly virescent white. Legs very pale ochraceous or nearly white, tarsi slightly darker.

Length, including tegmina, 8 millimeters; width 2 millimeters.

PALAWAN, Iwahig, P. I. (*W. Schultze* collector).

Type No. 10976 in Entomological Collection, Bureau of Science, Manila, P. I. Another specimen taken by Weber at the same place (11702 *C. M. Weber*) is 10 millimeters long and 2.25 millimeters wide but is otherwise identical with the type.

Subf. JASSINÆ.

Div. TARTESSUSARIA.

TARTESSUS Stål.

Ö. V. A. F. (1865) 156.

Type: *T. ferrugineus* Walk.

43. **TARTESSUS FERRUGINEUS** Walk.

Bythoscopus ferrugineus Walk., List Hom. (1851) 3, 865.

Bythoscopus malayus Stål, Freg. Eug. Resa, Ins. (1859) 290.

Bythoscopus biarcuatus, unilineatus, unifascia, Walk., MS.

Tartessus malayus Stål, *Ö. V. A. F.* (1865) 156; Sign., Ann. Soc. Ent. Fr. (1880) (5) 10, 357.

Tartessus ferrugineus Stål, loc. cit. (1870) 738; Spangb., loc. cit. (1877) 7; Sign., *ibid.* 356; Dist., *Fauna British Ind., Rhyn.* (1908) 4, 303, fig. 193.

This species appears to be quite well distributed over the oriental region as far north as Japan. It has been taken frequently in the Philippines.

PALAWAN, Bacuit and Bintuan, P. I. (11657, 11680 *C. M. Weber*), 2 specimens.

44. **TARTESSUS FIEBERI** Stål.

Tartessus fieberi Stål, *Ö. V. A. F.* (1865) 156, loc. cit. (1870) 738.

PALAWAN, Bacuit, P. I. (11708 *C. M. Weber*) a single specimen.

Div. JASSUSARIA.

JASSUS Fabricius.

Syst. Rhyng. (1803) 85.

Type: *J. nervosus* Fabr.

45. JASSUS ELEGANS Dist.

Jassus elegans Dist., Fauna British Ind., Rhyng. (1908) 4, 329.

PALAWAN, Iwahig, P. I. (10960 W. *Schultze*), 1 specimen.

This species, described from India, is here recorded from the Philippines for the first time.

ERRATA.

The following corrections should be made in Part I of *Rhynchota Palawanica*.
Vol. IV, Sec. A, 553.

Page 557, in middle of page, for *Coscomoris* read *Cosmocoris*.

Page 562, line 16, a period follows *Amy*.

Page 564, line 1, for *Tessaratominiæ* read *Tessaratominæ*

Page 564, page 11, from bottom of page, for ————— *Stål* read *Eumenotes*
obscura Stål.

Page 565, above Subf. *COREINÆ* insert Fam. *COREIDÆ*.

Page 572, line 15, delete comma after *British*.

Page 584, line 3, and page 588, line 12, for *and* read *&*.

Page 593, line 11, for *anadymone* read *anadyomene*.

ILLUSTRATIONS.

PLATE III.

- FIG. 1. *Hemispærius trimaculatus* Banks, sp. nov.
2. *Hemispærius stáli* Banks, sp. nov.
3. *Hemispærius parenthesis* Banks, sp. nov.
4. *Hemispærius transfasciatus* Banks, sp. nov.
5. *Jivatma triangulata* Banks, sp. nov.
6. *Dæda puncticlava* Banks, gen. et sp. nov.
7. *Mandesa vittifrons* Stål.
8. *Jada maculipennis* Banks, sp. nov.

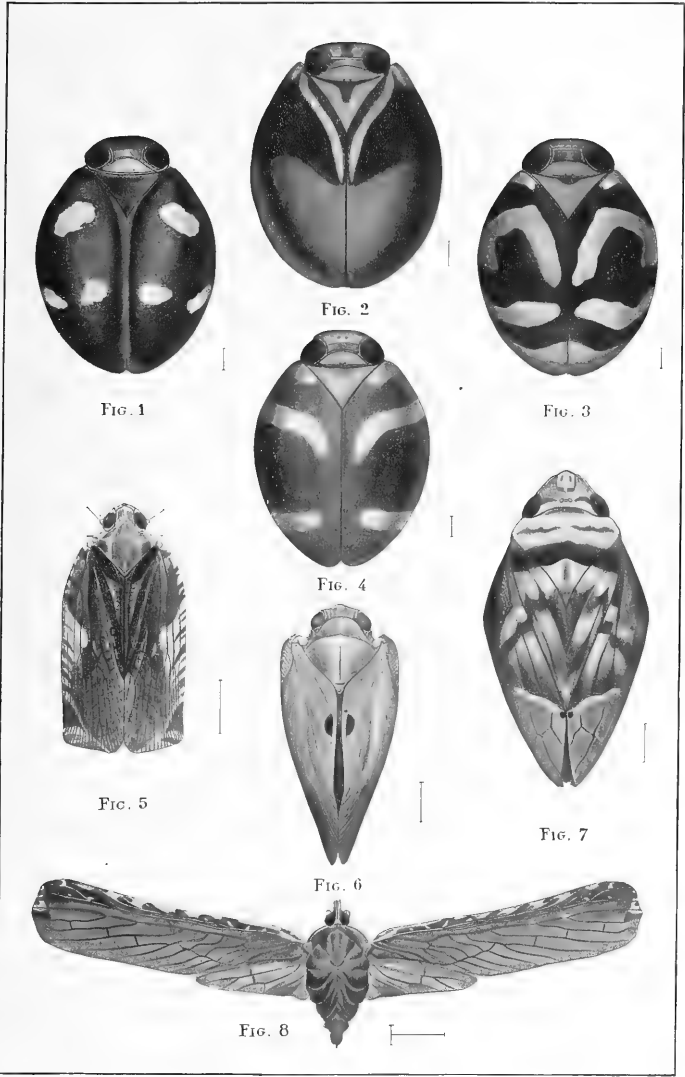

W. Schultze and J. Castro, ad nat. del. 1910.

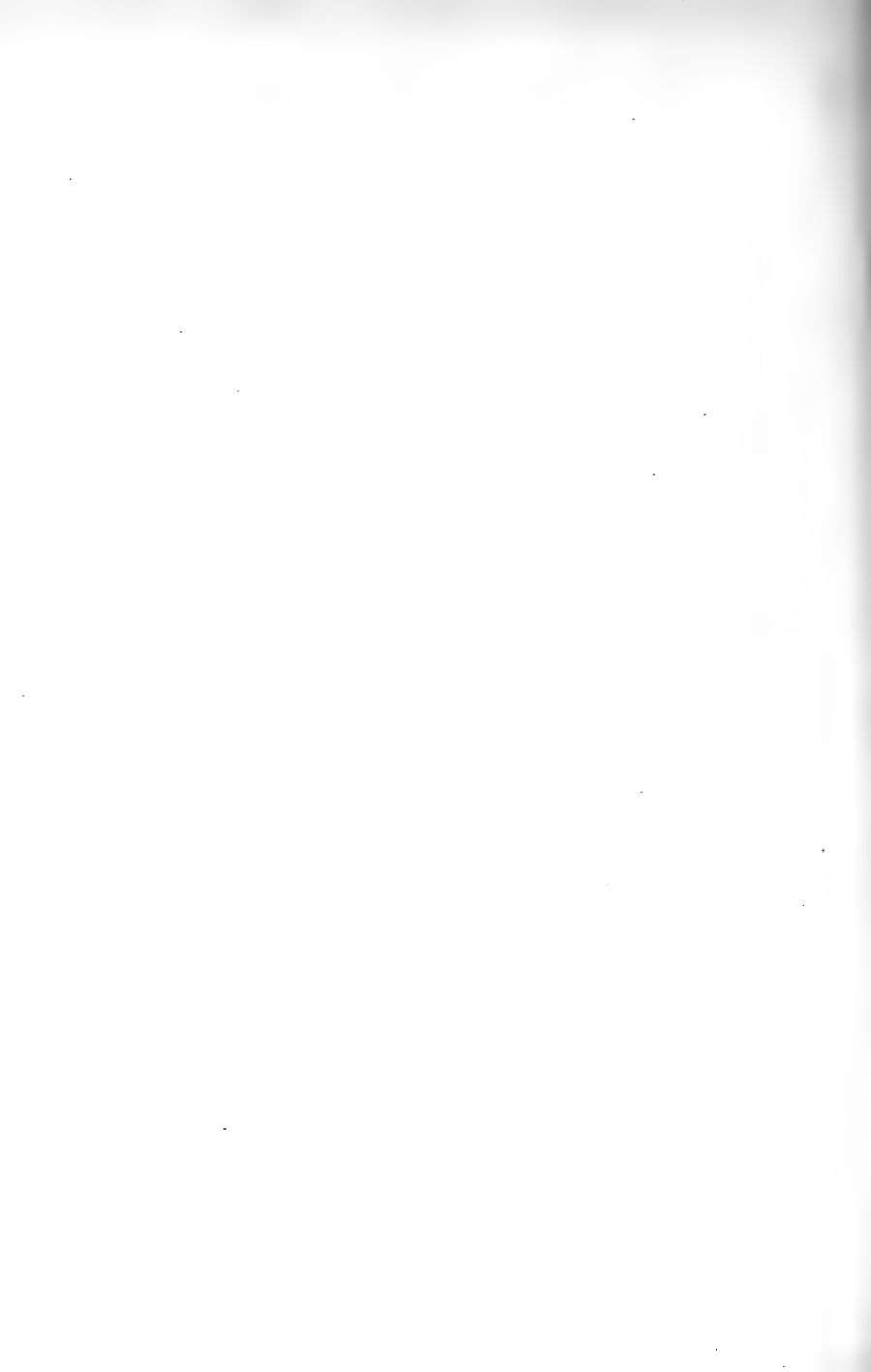

RHYNCHOTA PHILIPPINENSIA, PART I.

By W. L. DISTANT.

(London and Norwood Junction, England.)

When visiting London in 1908, Mr. Charles S. Banks, the Government Entomologist at Manila, brought a collection of Rhynchota for determination. This collection contained the following apparently undescribed species, and three others which have been described elsewhere, viz:

Macropes philippinensis Dist., *Rec. Ind. Mus.* (1909) 3, 165, Pl. 11, fig. 7, a. (Lygæidæ)

Catara philippinensis Dist., *loc. cit.* 172, Pl. 11, fig. 12, a. (Fulgoridæ)

Rihana atra Dist., *Entomologist* (1909) 207. (Cicadidæ)

There was also a number of species not enumerated in Stål's "Hemiptera Insularum Philippinarum," but these will be included in a complete list of the known species when more material has accumulated. These Islands probably contain a very exclusive Rhynchotal fauna.

Order RHYNCHOTA.

Suborder HETEROPTERA.

Family PENTATOMIDÆ.

CANTAO Amyot et Serville.

Hém. (1843) 29.

Type: *C. ocellatus* Thunb.

Cantao intermedius sp. nov.

Dull brownish ochraceous; basal area of head centrally continued along middle lobe, but not reaching apex, bluish black; pronotum usually with six small black spots arranged transversely in three pairs, of which those of the middle pair are usually closer together than the others; scutellum with eight black spots, two basal, two on each lateral area (one before, the other beyond middle) and two central (one near base, the other near apex); sternum and legs bluish black; lateral margins of sternum and abdomen beneath ochraceous; the latter with marginal and a double series of central bluish black spots; antennæ black, second joint very slightly longer than first, third, fourth and fifth subequal in length; rostrum black and reaching the base of the third abdominal segment; pronotum

thickly, finely punctate, except on anterior marginal area, the lateral margins nearly obliquely straight, the lateral angles broadly subacute and subprominent; scutellum thickly, finely punctate, except on basal area, with a central, longitudinal carination neither reaching base nor apex.

Long. incl. tegm. 17-19 millimeters, Exp. pronot. angl. 9-9.5 millimeters.

Hab. Philippine Islands; Batan Island (*R. C. McGregor* collector).

Separated from *C. ocellatus* Thunb., and allied to *C. rufipes* Dall., by the length of the rostrum. From *C. rufipes* it is to be distinguished by the more oblique and less sinuate lateral margins of the pronotum, the lateral angles of which are also much more obtuse; the scutellum is broader and somewhat shorter; color different; from both species it differs by having the posterior lateral spots to the scutellum transverse and not oblique.

PEGALA Stål.

Öfv. Vet-Ak. Förh. (1867) 522.

Type: *P. biguttula* Hagl.

Pegala clemensæ sp. nov. (Plate I, fig. 2.)

Head, pronotum and scutellum pale ochraceous; head with the lateral margins and the anterior lateral margins of the central lobe, black; pronotum with the posterior margin (broadly) and the margins of the lateral angles (narrowly) castaneous; scutellum with the basal half (in type) sordidly pale ochraceous; corium castaneous brown, with a pale ochraceous subcostal spot behind middle; membrane hyaline with a transverse pale fuscous fascia behind middle; body beneath and legs pale luteous, two black spots on each side of mesosternum and one on each side of metasternum, anal processes more or less castaneous; legs minutely spotted with piceous; first, second and third joints of antennæ ochraceous with their apices piceous, fourth and fifth joints piceous, third joint longer than second, third, fourth and fifth almost subequal in length; pronotum sparsely, brownly punctate on central disk, the castaneous posterior margin more thickly punctate; scutellum sparsely punctate, on posterior area centrally longitudinally sulcate, an elongate marginal castaneous spot on each side beyond middle; corium thickly, coarsely punctate; rostrum about reaching the posterior coxæ, its apex and the upper surface of second and third joints piceous; mesosternal laminate carination continued before the anterior margin of the prosternum; apex of scutellum obtusely angulate; posterior pronotal angles not prominent; posterior angles of the sixth abdominal segment spinously produced.

Long. 9 millimeters, Exp. pronot. angl. 5.5 millimeters.

Hab. Philippine Islands; Mindanao, Camp Keithley (*Mrs. M. S. Clemens* collector).

Allied in general form and appearance to *P. metaphœa* Walk., but pronotum and scutellum much less punctate; corium paler with pale ochraceous subcostal spot, antennæ with the first three joints pale, with their apices piceous; rostrum shorter, etc.

Family LYGÆIDÆ.

PACHYGRONTHA Germar.

Silb. Rev. Ent. (1837) 5, 152.

Type: *P. lineata* Germ.

Pachygrontha nigrolineata sp. nov. (Plate I, fig. 3.)

Ochraceous, somewhat thickly, coarsely and darkly punctate; pronotum with the extreme lateral margins pale ochraceous and levigate preceded by a submarginal fascia formed by black punctures on each side; a longitudinal black fascia on each corium commencing near middle of clavus and continued on membrane to about one-fourth before apex where it is obliquely deflected to margin by a broken continuation; apical fourth of membrane exhibiting a central black longitudinal line probably a reflection from the abdomen beneath it and with two small piceous spots on apical margin, the membrane between the black longitudinal lines distinctly paler in color; head beneath and sternum brownish grey, thickly darkly punctate; abdomen beneath pale ochraceous, with a sublateral fascia on each side and a central fascia on the last two segments piceous brown; stigmal spots black; legs ochraceous, somewhat thickly speckled with piceous, anterior femora, above, more prominently speckled with black; antennæ with the first and second joints subequal in length, apex of first joint moderately thickened and piceous, third shorter than second, fourth mutilated in type; head, including eyes, about as broad as anterior margin of pronotum, anteriorly shortly, spinously produced on each side; pronotum scarcely or but little longer than broad at base, more thickly punctate on lateral areas than on middle area; scutellum with a central pale levigate line and a small pale spot near each basal angle; corium with the extreme lateral margin levigate, except on basal fourth where it is punctate; clavus longitudinally punctate; anterior femora somewhat strongly spined beneath, anterior tibiæ curved.

Long. 12 millimeters.

Hab. Philippine Islands; Manila (*Charles S. Banks* collector).

Family TINGIDIDÆ.

HORMISDAS gen. nov.

Type: *H. pictus* sp. nov.

Head with seven porrect spines of which three are apical, the central one considerably the longest, a shorter and more robust spine on each side between eyes and base of antennæ and two long spines extending from base of head to about base of antennæ; antennæ long, distinctly pilose, first and second joints short, robust, second shorter than first and more globose, third slightly more than twice as long as fourth; rostrum reaching the intermediate coxæ; pronotum longer than broad, continuously tricarinate, the lateral margins ampliate, bi-areolate and longly, porrectly spined at the anterior angles; scutellum concealed; elytra elongate, concavely sinuate on costal margin beyond middle, the apex a little widened and rounded, discoidal area small, about as long as pronotum, subcostal area with a single series of areolets, costal area bi-areolate, the areolets and those on sutural area somewhat large and prominent; mesosternum with two longitudinal central ridges between which the rostrum is enclosed; legs slender.

This genus has a superficial resemblance to *Hædus* Dist., from South Africa, but its real affinity is with the Ceylonese genus *Celantia* Dist.

Hormisdas pictus sp. nov. (Plate I, fig. 1, a, b.)

Head, antennæ and pronotum pale fuscous brown, the latter with the amplified lateral margins hyaline, with the edges of the areolets pale brownish; elytra with the discoidal and sutural areas pale fuscous, the disks of the first and the margins of the latter piceous, the narrow subcostal area greyish brown and the costal area hyaline with the edges of the areolets pale brownish; body beneath piceous brown; legs pale greyish; structural characters as in generic diagnosis.

Long. 3.5 millimeters.

Hab. Philippine Islands; Manila (*Charles S. Banks* collector).

Family HEBRIDÆ.

MERRAGATA Buchanan White.

Ann. Mag. Nat. Hist. (1877) (4) 20, 113.

Type: *M. hebroides* White.

Merragata cruciata sp. nov. (Plate I, fig. 7.)

Head, pronotum and scutellum black, somewhat palely, finely pilose; anterior margin of pronotum piceous brown; corium brownish ochraceous, the apical margin paler; membrane piceous, almost completely crossed each way by a large cruciform pale ochraceous fascia; body beneath black, legs, antennæ and rostrum ochraceous; antennæ five-jointed, first joint a little longer than second, third a little longer than either fourth or fifth, the latter (excluding base) a little darker in hue; pronotum with the posterior angles a little tuberculately prominent; scutellum with the apex broadly, angularly incised.

Long 2.33 millimeters.

Hab. Philippine Islands; Rizal, Montalban Gorge (*Charles S. Banks* collector).

Family REDUVIDÆ.

ACANTHASPIS Amyot et Serville.

Hém. (1843) 336.

Type: *A. flavovaria* Hahn.

*ACANTHASPIS DISTANTI*¹ Banks. (Plate I, fig. 12.)

Acanthaspis distanti Banks, *This Journal*, Sec. A (1909), 4, 584.

Hab. Philippine Islands, Bohol (*A. Celestino* collector).

Sibuyan Island (*R. C. McGregor* collector).

¹At the time of the receipt of this MS. from Mr. Distant, a paper of my own containing this species under a different name was in press, and so could not be changed. I was, however, able to have the name *distanti* substituted before the publication of my paper. (C. S. BANKS.)

SCADRA Stål.

Öfv. Vet.-Ak. Förh. (1859) 176 and 182.

Type: *S. lanius* Stål.

Scadra illuminata sp. nov.

Head, pronotum and sternum shining black; eyes testaceous; pronotum with the lateral margins of the posterior lobe and a central basal longitudinal spot pale ochraceous; scutellum black, the two spinous apical angulations connected with raised marginal carinae, pale ochraceous; hemelytra dull black, extreme base of clavus, costal margin of corium (not extending to apical angle), connexivum and abdomen beneath pale ochraceous, the latter with four transverse segmental spots on each lateral area and the anal segment, black; rostrum and intermediate legs (remaining legs mutilated in type) black; rostrum with the first joint about as long as remaining joints together; pronotum broadly centrally sulcate, the sulcation not reaching the basal margin; scutellum with two apical spinous angulations. (Antennæ mutilated.)

Long. 12 millimeters.

Hab. Philippine Islands; Negros Occidental, Maa (*Charles S. Banks* collector).

Allied to *S. lanius* Stål.

PHEMIUS Stål.

Öfv. Vet.-Ak. Förh. (1859) 200.

Type: *P. tibialis* Westw.

Phemius minor sp. nov. (Plate I, fig. 9.)

Uniformly black or piceous; tibiæ and tarsi ochraceous, apices of the latter black; antennæ ochraceous, bases and apices of the joints more or less black; rostrum reddish, basal joint black; anterior lobe of pronotum with two erect tubercles.

Allied to *P. tibialis* Westw., but a smaller species with the connexivum much less and more angularly developed; apices of femora not ochraceous; basal joint of rostrum black, etc.

Long. ♂ and ♀ 21–29 millimeters.

Hab. Philippine Islands; Benguet, Irisan River (*R. C. McGregor* collector).

AGA gen. nov.

Type: *A. albomarginalis* sp. nov.

Body subelongate; head longer than the pronotum, the postocular area longer than the anteocular and behind eyes wider than the anteocular, moderately attenuated toward base; ocelli distinctly elevated; antennæ about as long as the body (excluding membrane), first joint about as long as head and anterior lobe of pronotum; rostrum reaching the anterior coxæ, second joint longer than the first which extends to the eyes; pronotum distinctly, transversely constricted before middle, the anterior lobe convex and broadly, longitudinally sulcate, posterior lobe moderately convex, centrally, foveately depressed, strongly, longitudinally impressed before the lateral angles, posterior lobe about twice as broad as anterior lobe; scutellum triangular, apex obtuse; membrane longly passing the

abdominal apex, about half as long again as corium; legs of moderate length, longly, strongly pilose, not nodulose, tibiæ as long as femora and coxæ together; abdomen with the fourth and fifth segments not dilated.

Allied to *Stachyomerus* by the pilose legs, but differing in the absence of the femoral spines; the shorter and pilose legs, etc., separate it from *Lamprospodrus*; from *Pacilosphodrus* it is to be distinguished by the longer head, etc.

Aga albomarginalis sp. nov. (Plate I, fig. 5, a.)

Head, anterior lobe of pronotum, rostrum, sternum and legs castaneous brown; posterior lobe of pronotum, scutellum, corium, membrane and abdomen beneath pale ochraceous; anterior margins of anterior and posterior pronotal lobes, basal margin of scutellum connected with a transverse fascia crossing base of corium, and strong lateral suffusio to sternum tomentosely white; abdomen beneath finely, somewhat longly pilose; legs longly, coarsely pilose; structural characters as in generic diagnosis.

Long. incl. membrane 13 millimeters, Exp. post. pronot. angl. 3 millimeters.

Hab. Philippine Islands; Negros Occidental, Mailum, Bago (*Charles S. Banks* collector).

PHORTICUS Stål.

Rio Jan. Hem. (1858) 1, 69.

Type: *P. viduus* Stål.

Phorticus cardui sp. nov. (Plate I, fig. 4.)

Above orange-red; head, a large quadrate spot at each basal angle of the pronotum, scutellum, two somewhat large rotundate spots to corium (one near apex of scutellum, the other near the posterior angle) and the membrane black; apex of scutellum and margins of membrane orange-yellow; body beneath orange-red; head beneath and a spot at each basal angle of the prosternum black; legs and antennæ ochraceous; body and legs pilose; antennæ with the first and second joints incrassate, first joint slightly passing apex of head, second longer than first, attenuate at base; pronotum obscurely, transversely impressed behind middle and near base, the lateral margins from this impression narrowed and rounded to head, and longly pilose; scutellum with a faint central longitudinal ridged line; connexivum exposed from about one-third from base; rostrum about reaching middle of mesosternum.

Long. 6 millimeters.

Hab. Philippine Islands; Manila (*Charles S. Banks* collector).

NABIS Latreille.

Gen. (1807) 3, 127 (part).

Type: *A. apterus* Fabr.

Nabis latreillei sp. nov.

Head and anterior lobe of pronotum pale brownish ochraceous, posterior pronotal lobe pale ochraceous; scutellum brownish ochraceous, with a spot on each side and the apex pale ochraceous; corium pale ochraceous, clavus, a broad irregular medial fascia just beyond apex of clavus and the apical angular area dark brownish ochraceous; membrane hyaline, the basal angle and a transverse fascia near middle dark brownish ochraceous; body beneath, rostrum and legs

ochraceous, apices of intermediate and posterior tibiae more or less pale sanguineous; head with the ante- a little longer than the postocular area, the apex subacutely produced; antennæ finely pilose, first joint shorter than second; rostrum with the first joint a little longer than second, third a little more than half the length of second, first joint shorter than first joint of antennæ, pronotum with the anterior lobe centrally, longitudinally impressed, posterior lobe thickly, finely granulate, lateral margins finely, shortly pilose; membrane considerably passing the abdominal apex.

Long. 9 millimeters.

Hab. Philippine Islands; Rizal, Montalban Gorge (*Charles S. Banks* collector).

Allied to *N. brevilineatus* Scott, from Japan.

Family CAPSIDÆ.

DISPHINCTUS Stål.

Öfv. Vet-Ak. Förh. (1870) 668.

Type: *D. falleni* Stål.

Disphinctus stáli sp. nov. (Plate I, fig. 6.)

Black, or piceous black; anterior collar to pronotum ochraceous; a central longitudinal fascia to posterior pronotal lobe (narrow anteriorly and broadened and amplified at basal margin), scutellum and abdomen beneath stramineous, the latter with black suffusions, principally a spot on each side behind base and the greater part of the apical area; legs ochraceous, apices of anterior and intermediate femora and the whole of the tibiae pale castaneous brown, posterior legs black, posterior femora with a central pale ochraceous annulation, tarsi more or less piceous or black; antennæ black, first joint ochraceous at base, second about five times as long as first, remaining joints mutilated in typical specimen; corium piceous black, the cuneus distinctly paler and more brownish, membrane brownish ochraceous.

Long. 9 millimeters.

Hab. Philippine Islands; Bataan, Lamao (*H. Cuzner* collector).

Allied to *D. sahlbergii* Stål.

Disphinctus philippinensis sp. nov.

Above brownish ochraceous; head above, rostrum, pronotal collar, a central narrow longitudinal fascia and narrow posterior angular margins to posterior pronotal lobe, a lateral fascia on each side of scutellum, and cuneus pale ochraceous; a small, obscure, linear reddish spot on disk of corium; membrane obscure semihyaline, the basal area piceous; head beneath, sternum and legs, reddish ochraceous, abdomen beneath dull ochraceous; antennæ with the first joint castaneous, its base ochraceous, second joint black, nearly three times as long as first (remaining joint mutilated in typical specimen); connexivum projecting beyond posterior half of corium, ochraceous but more or less black inwardly. Intermediate and posterior legs mutilated in specimen described.

Long. 8.5 millimeters.

Hab. Philippine Islands; Rizal, Montalban Gorge (*Charles S. Banks* collector).

Allied to *D. reuteri* Stål.

Suborder HOMOPTERA.

Family FULGORIDÆ.

SCAMANDRA Stål.

Stett. Ent. Zeit. (1863) 24, 232.

Type: *S. rosea* Guér.

Scamandra banksi sp. nov. (Plate I, fig. 8.)

Head and pronotum olivaceous brown, eyes ochraceous; mesonotum castaneous; abdomen above brownish, thickly covered with a white, waxy secretion; body beneath pale chocolate-brown, face and legs dark olivaceous brown; tegmina with a little less than basal half dark olivaceous, remaining area and the extreme base brownish testaceous, the basal olivaceous area with two transverse pale ochraceous fasciæ, the first obliquely directed inward, the second irregular and marking the boundary line of the olivaceous area, the brownish testaceous area containing a number of very obscure, slightly paler spots; wings brownish testaceous, the anal area suffused with a white, waxy secretion, posterior margin from anal margin to commencement of apical area, greyish white, veins and cross-veins on central area olivaceous or greyish, the basal half of upper half of wing olivaceous, outer margin of apical area pale brownish; tubercle at base of upper surface of posterior tibiæ short, obtuse; pronotum and mesonotum more or less finely wrinkled, the first with an obscure fine longitudinal carinate line, the latter centrally, longitudinally sulcate; face with two strong central carinations, the lateral margins also strongly carinate.

Long. excl. tegm. 21 millimeters, Exp. tegm. 73 millimeters.

Hab. Philippine Islands; Mindanao, Camp Keithley (*Mrs. M. S. Clemens* collector).

Allied to *S. saturata* Walk., and *S. lydia* Stål.

NEODICTYOPHARA gen. nov.

Type: *N. nasuta* sp. nov.

General characters of *Dictyophara*. Head in type longly produced; face and clypeus centrally longitudinally carinate; rostrum reaching the intermediate coxæ; pronotum angularly emarginate at base, tricarinate; mesonotum tricarinate, the carinations united near anterior margin; femora shorter than tibiæ, posterior tibiæ (in type) armed with about four spines, the one near base very short; tegmina about three times longer than broad, costal margin somewhat strongly arched at base, moderately narrowed at apex, costal area with transverse veins, subcostal area much broader, near base nearly twice as broad; from end of cell three longitudinal veins, the upper and lower apically bifurcated for about half their length; clavus without a transverse vein, apical area reticulate, preceded by a series of prominent transverse veins; wings of moderate size, the veins bifurcating toward apical area and forming a series of irregularly sized and shaped apical cells.

Neodictyophara nasuta sp. nov. (Plate I, fig. 11, a, b.) -

Head, pronotum, mesonotum, body beneath and legs virescent; abdomen above greyish white; tegmina virescent; wings greyish white; head in front of eyes

about twice as long as pronotum and mesonotum together, somewhat strongly, upwardly recurved, its extreme apex subtruncate and piceous, the lateral margins above strongly ridged as are also the lateral margins of the face, central carination to face and clypeus sharply prominent; tegmina transversely veined in costal area, irregularly transversely wrinkled in subcostal area; other structural characters as in generic diagnosis.

In the unique ♀ type the genital apparatus above consists of two long parallel spinous appendages, the apices of which are piceous.

Long. ♀ excl. tegm. 15 millimeters, Exp. tegm. 29 millimeters.

Hab. Philippine Islands; Manila (*Charles S. Banks* collector).

SYRGIS Stål.

Öfv. Vet-Ak. Förh. (1870) 758.

Type: *S. acutus* Walk.

SYRGIS ACUTUS Walk.

Issus acutus Walk., List Hom. (1851) 2, 369.

Syrgis simplex Stål, (part) *Öfv. Vet-Ak. Förh.* (1870) 759.

Syrgis acutus Melich. (part) *Abh. K. K. Zool.-Bot. Ges. Wien.* (1906) 308.

SYRGIS SIMPLEX Walk.

Issus simplex Walk., List Hom. Suppl. (1858) 92.

Syrgis simplex Stål, (part) *Öfv. Vet-Ak. Förh.* (1870) 759.

Syrgis acutus Melich. (part) *Abh. K. K. Zool.-Bot. Ges. Wien.* (1906) 308.

The above two species are quite distinct. In *S. acutus* the anteocular portion of the head is longer than the basal space between the eyes; in *S. simplex* the head only projects a little in front of the eyes and is only about one-third the length of the basal space between the eyes.

Syrgis fasciatus sp. nov. (Plate I, fig. 10.)

Fuscous brown; body beneath and legs a little darker; face castaneous brown, the base narrowly black and with two somewhat ill-defined transverse fasciæ (the first before and the second beyond middle), apical margin before clypeus and the posterior portions of lateral margins, pale ochraceous; tibiæ, tarsi and annulations to femora, piceous; sternum mottled with piceous; tegmina with three irregular transverse piceous fasciæ, the first basal, the second broad and at about middle, its costal half broad and sub-triangular and then continued to clavus by two narrow bifurcations, the third fascia narrow, continuous and subapical, apical margin spotted with piceous; vertex longer than in *S. acutus* Walk., the anteocular portion longer than the basal space between the eyes, vertex and pronotum strongly, centrally, longitudinally carinate; mesonotum more faintly tricarinate; face strongly, centrally, longitudinally carinate.

Long. 7 millimeters.

Hab. Philippine Islands; Manila (*Charles S. Banks* collector).

Allied to *S. acutus* Walk., from which it differs by the longer and more produced vertex and the fasciated face and tegmina.

MINDURA Stål.

Rio Jan. Hem. (1862) 2, 69.

Type: *M. alligata* Walk.

MINDURA ALLIGATA Walk.

Mogodina alligata Walk., Journ. Linn. Soc. Lond., Zool. (1868) 10, 170.

Mindura subfasciata Stål, Öfv. Vet-Ak. Förh. (1870) 770; Melich. Mon.
Ricaniid. (1898) 302.

Melicher has given Stål's name priority, but he has given 1870 instead of 1868 as the date of Walker's description.

ILLUSTRATIONS.

PLATE I.

- FIG. 1, *a, b*. *Hormisdas pictus* Dist., gen. et sp. nov.
2. *Pegala clemensæ* Dist., sp. nov.
3. *Pachygrontha nigrolineata* Dist., sp. nov.
4. *Phorticus cardui* Dist., sp. nov.
5. *a*. *Aga albomarginalis* Dist., gen. et sp. nov.
6. *Disphinctus stáli* Dist., sp. nov.
7. *Merragata cruciata* Dist., sp. nov.
8. *Scamandra banksi* Dist., sp. nov.
9. *Phemius minor* Dist., sp. nov.
10. *Syrgis fasciatus* Dist., sp. nov.
11, *a, b*. *Neodictyophara nasuta* Dist., gen. et sp. nov.
12. *Acanthaspis distanti* Banks.

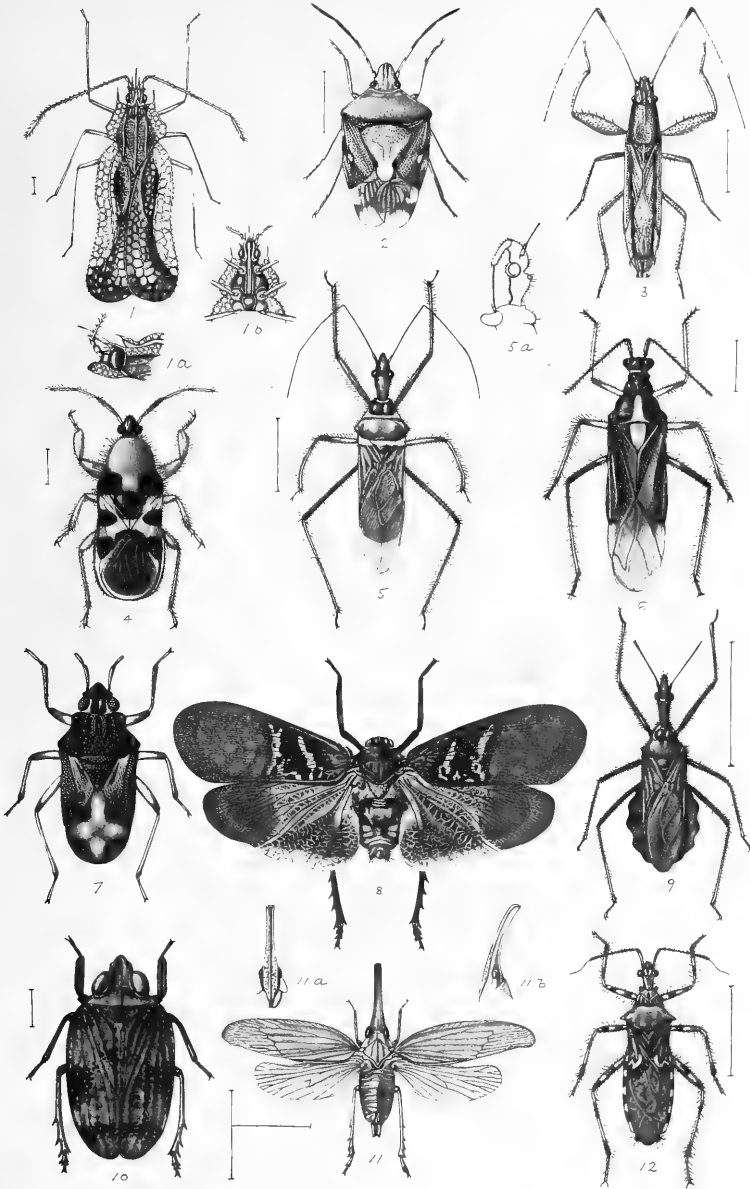

H. Knight, ad nat. del. 1909.

PLATE I.

ON THE MYRMECOPHILY OF CATERPILLARS OF CATO-
CHRYSOPS CNEJUS FABR.

By H. VIEHMEYER.

(Dresden, Germany.)

[Translated and edited by Charles S. Banks.]

In a collection of larvæ of Lycænidae received from Mr. W. Schultze, of the Bureau of Science, Manila, P. I., I have noted, among other interesting forms, the species designated in the title of this paper.

The larvæ belong to those species which bear a symbiotic relationship to ants. De Nicéville¹ thus designates them and in doing so says, "Extensile organs on the twelfth segment small." He mentions *Camponotus rubripes* Drury, subspecies *compressus* Fabr. (det. Forel.) as visiting ants. In the same work he gives the following notes by Green, of Ceylon: "Both species (*Tarucus theophrastus* Fabr. and *Catochrysops cnejus* Fabr.) have the power of emitting some agreeable odor or juice from the small movable horns situated on the upper side near the tail. These horns are capable of being projected and retracted at pleasure." What De Nicéville here says regarding the peculiar organs of the larvæ of *C. cnejus* is very incomplete and is therefore liable to give a false impression.

The ant-attracting organs of the lycænid larvæ were first fully described and figured by Brants² (1865) and Guenéé³ (1867), apparently independently of each other. According to them, these larvæ possess two distinct organs: The first on the dorsal surface of the third from the last abdominal segment (the eleventh body-segment, including the head), on the median line and near the posterior margin of the segment having the form of a straight sulcus surrounded by two swellings or lips; upon the penultimate (twelfth body-segment) toward the outer half and behind the last pair of stigmata is another pair of eversible (evaginating) and inversible (invaginating) cylinders, the upper edges

¹ The Butterflies of India, Burmah and Ceylon (1890), 3, 17.

² Sepp. Jan. Christian, Nederlandsche Insekten (1870), (2) pt. 2, 59, pl. 13.

³ D'un Organe particulier que présente une chenille de Lycæna. *Ann. Soc. Ent. Fr.* (1867), (4) 7, 665-668, pl. 13, figs. 9-12.

of which are provided with a crown of short, hair-like bristles. Edwards⁴ discovered on the caterpillars of *Lycæna pseudargiolus* Boisd., that the slit-like pores gave forth a drop of liquid which was quickly licked up by the ants and positively carried off and that the tubes upon the twelfth segment neither voided a drop of liquid nor did the ants pay any attention to them.

In spite of the exceedingly clear and detailed description and differentiation of the organs as given by Edwards, later observers have repeatedly put forth the assertion that only one of the two pairs is functional or that the ants lick the evaginating tubes. Both these latter statements are certainly false in so far as they apply to the larvæ before the second moult. Moreover, the caterpillars of *C. cnejus* show clearly the fluid-producing pore upon the third from the last segment, if De Nicéville does not err. I do not doubt but that when more careful research is made the pore will be found upon all larvæ in which De Nicéville has indicated only tubes.

For *C. pandava* Horsf. and *Polyommatus bæticus* Linn., at least, I am able to demonstrate both organs. Apparently the only exception seems to be *Curetis thetis* Dru., but according to De Nicéville they appear not to be visited by ants, and their tubes are to be differentiated from those of the myrmecophilous lycænid caterpillars as well by their form as by their habits. It is therefore equally as possible that we have to deal in this case with a substantially different organ.

The more important of the two organs are the secreting pores, for they furnish the attraction for the ants; but what the relationship of the tubes is appears still uncertain. One might consider them as defensive weapons or at least as the rudiments of such, as signal tubes, or as scent organs for attracting the ants. A partial explanation of their relationship is given by the earlier stages of the caterpillars of *C. cnejus*. It should be noted that the development of both organs is not symmetrical, but that they are drawn toward each other. Edwards appears to have studied the earlier stages of these caterpillars in order to determine the existence of the myrmecophilous organs. He says, "The outward openings (the tubes) and the orifice in [segment] 11 are visible in the youngest larval stages, but till near maturity the larva has no use for the tubes and can not emit the secretion."

In the caterpillars of *C. cnejus* the relationship is different. At the time of leaving the egg it possesses neither pore nor tubes. After the first moult the pore appears; after the second, the tubes. This agrees perfectly with the observations of Scudder⁵ on the caterpillars of *Everes*

⁴ On the Larvæ of *Lycæna Pseudargiolus* and Attendant Ants. *Can. Ent.* (1878), 10, 131-136.

⁵ The Butterflies of the Eastern United States and Canada. (1882), 2, 914 and 959.

comyntas Godt. He disposes of the question of the presence of evaginating tubes, or "caruncles" as he calls them in parentheses, by, "First noticed in the third stage." Indeed, of the caterpillars of the genus *Rusticus* Hübn., he then says, "A transverse slit in the middle of the dorsum of the seventh abdominal segment appears in the third stage, but apparently the caruncles of the eighth segment do not appear until the fourth stage."

From the extraordinary similarity of the caterpillars and the almost perfect similarity of structure of the myrmecophilous organs, I do not believe that such a striking difference could exist, but rather think that an error lies therein. Another question here arises, and that is as to whether the organs, as Edwards questioned, are really functional in the earlier stages of the caterpillar's existence.

I have recently noticed that Gillmer⁶ also affirms that in caterpillars of *Lycæna argyrognomon* Bergstr., the pore is developed first in the second stage and the tubes first in the third stage. It is then certain that the earlier statements concerning this are not exact.

Finally, the first stages of the caterpillar of *C. cnejus* must be considered from another standpoint. Thomann⁷ has made certain careful studies upon the integument of the caterpillars of myrmecophilous Lycænidæ. He found that the skin is covered with "star-shaped warts so exceedingly small that they can not be seen by the naked eye and that from their centers grows a single minute bristle with, usually, a tuft of fine hairs at its tip." He sees in these growths possible organs of touch, which may serve to notify the caterpillars of the return of the ants.

This view appears to be reasonable, especially as in the region of the myrmecophilous organs there is usually to be found an accumulation of these tufted hairs. In the young caterpillars of *C. cnejus* there are three interesting facts to be noted: That the tufted hairs appear after the first moult simultaneously with the opening of the pore; in this stage they remain proportionately sparse and appear especially around the pore, but not in masses; after the second moult, they show in the same numbers and with the same arrangement as in the fully developed larvæ.

The ant which visits this caterpillar is *Polyrhachis dives* Smith (det. Forel.) Green's supposition that the pupation of the caterpillar takes place in the ant's nest appears to be without foundation. The appearance of caterpillars of Lycænidæ in ants' nests seems to me, at least for the European species, to be more or less accidental and then only if the ants' nests are upon the ground in the immediate vicinity of the food plant of the caterpillar.

⁶Ein literarischer Beitrag zur Grossschmetterlingsfauna von Lübeck. *Arch. d. Ver. d. Naturgesch. in Meck.* (1907), 61.

⁷Schmetterlinge und Ameisen. (1901).

LIST OF THE MYRMECOPHILOUS LYCÆNIDÆ OF THE INDO-AUSTRALIAN REGION.

Gerydus symethus Cramer.	Catochrysops cnejus Fabr.
Cyaniris puspa Horsf.	Tarucus theophrastus Fabr.
Lycæna astrarche Bergstr.	Castalius ananda deNicév.
Lycæna icarus Rotb.	Polyommatus bœticus Linn.
Lycæna hylas W. V.	Liphyra brassolis Westw. ⁵
Zizera lysimon Hübn.	Hypolycæna phorbas Fabr.
Azanus ubaldus Cram.	Arhopala meander Boisd.
Chilades laius Cram.	Aphnæus vulcanus Fabr.
Chilades trochilus Freyer.	Rapala schistacea Moore.
Lycænesthes emolus Godart.	Ogyris genoveva Hewits.
Lampides celeno Cram. (ælianus Fabr.)	Jalmenus evagoras Don.
Catochrysops pandava Horsf.	Jalmenus ictinus Hewits.

⁵ Doubtfully myrmecophilous, at least in the sense here indicated.

A MYRMECOPHILOUS LYCÆNID CHRYSALIS FROM THE
PHILIPPINES.

By H. VIEHMEYER.

(Dresden, Germany.)

[Translated by W. Schultze.]

At the beginning of the year 1908, Mr. W. Schultze, of Manila, sent me a very interesting lepidopterous chrysalis, together with some ants, for which I here wish to express my thanks. Concerning the locality the following information is taken from his letter:

"One of my friends (Mr. H. M. Curran) had a large, old tree in Santa Maria, Laguna Province, cut down in order to obtain certain epiphytic plants. As the tree lay on the ground, he observed that ants had built an earthen nest among the roots of one of the epiphytes, and that the nest had been broken by the fall of the tree. His interest was further aroused when he noticed that the furious ants had grouped themselves around certain objects within special cells fastened to the bark of the tree as if to defend these objects. His astonishment was great when he found that the immovable objects were lepidopterous chrysalids. He counted about sixteen specimens. In using a forceps for their extraction from the nest he crushed three, after which he succeeded in loosening six more with his hands. These he placed in a glass bottle and brought them, four days later, to the laboratory."

So much for the facts. Unfortunately, no butterflies emerged from the chrysalids, although they were in an advanced stage of development.

We are in all probability dealing with a species of the genus *Arhopala*. The ants were *Camponotus quadrisectus* Smith (det. Forel). First of all, so far as the particular nest design of *Camponotus* is concerned, one is strikingly reminded of the hanging nests or "ant gardens" which E. Ule observed in the Amazon region.¹ In our case, what he says about *Camponotus femoratus* Fabr., would appear to best apply to the question namely:²

"The nests of these ants are often built high up in the trees, though they are found just as abundant in shrubs more or less close to the ground. The primary

¹ Ameisengärten im Amazonengebiet. In *Engler's bot. Jahrb.* (1902), 30, No. 68, 45-52.

² Blumengärten der Ameisen am Amazonenstrome. In Karsten u. Schenck, *Vegetationsbilder, 3te Reihe, Heft I, Taf. 1-6.*

foundations of these nests consist for the most part of very small, irregular accumulations of earth. The whole structure rarely attains the size of a man's head and is surrounded by a somewhat thin, earthy, crust-like cover. Inside it consists of numerous irregular chambers having no particular design. Plants soon begin to grow over the entire surface of the nest from seeds previously carried in by the ants. Some of these plants attain a considerable size. Still more earth is now carried in by the ants so that the plants do not lack material for nutrition and can develop into enormous clusters. Since in this manner the ants often cultivate flowering plants, their nests may be called 'flower gardens of ants' in analogy with Möller's 'fungus gardens.' As these plants, thus bred by the ants, are, by reason of their care, able to live in the air in the same manner as epiphytes on other plants, I shall call them 'ant-epiphytes.'

In this comparison too much importance should not be attributed to the fact that the plant was probably a true epiphyte and received no direct benefit from the accumulation of earth by the ants. The relationship between the plants and the ants here existing is not symbiotic in the strictest sense, because it directly benefits only the ants, in that the interlacing of the plant roots increases the stability of the nests. The benefit which the plants receive from this relationship is a very equivocal and incidental one. As a rule, one does not speak of benefit, but rather of injury, so long at least as it is not proved that the ants make selections among plant species. It is therefore not difficult to imagine similar conditions in the case of *Camponotus quadrisectus* Smith; on the other hand, it is also easily possible that the ants take possession of the interlacing roots simply as a suitable place for their nest. I simply wish to indicate here the probability of the first-mentioned association, in order to call attention to these relations, further observations upon the construction of the nests of *C. quadrisectus* being needed in order to show which of the two possibilities applies to the case in question.

The relation of the ants to the lycænid chrysalids is, however, clearer and more interesting. The pupa sent to me is about 17 millimeters long and shows the closest similarity to the dominant forms in the genus *Arhopala*. The abdominal extremity is developed into a large cupule or pulvillus-like depression, presumably similar to that of many of its closely related allies, at present unknown, and by means of which it was fastened to the bark of the tree within the ants' nest. Dorsally, on the seventh abdominal segment, exactly in the place where the myrmecophilous lycænid larvæ have the opening of the secretory gland, there is situated an oval, chitinous, crater-shaped cavity 1.3 millimeter in length and 0.7 millimeter in width. Its edges consist of strong, dark-colored chitin and project considerably above the surrounding surface. Inside the oval zone the chitin is much thinner and readily distinguishable by its yellowish color, though especially so when viewed by transmitted light. When the butterfly is withdrawn from the skin of the pupa, one notices plainly that a fine transverse incision is present between two chitinous lamellæ, which extend into the crater from the cephalic and

caudal borders, respectively. A direct connection is thus indicated as existing between the interior of the body of the pupa and the chitinous crater.

It is a great pity that the pupa sent to me was not suitable for sectioning. From the striking size of the chitinous crater and the connection with the inside of the pupa, we may conclude with comparative safety that secretory glands are also present. This pupa must therefore be considered myrmecophilous, and certainly, as such, of a species which actually supplies the ants with some kind of secretion. It is an ascertained fact that the pupæ of myrmecophilous Lycænidæ are often found in ant nests. So far as all the palearctic species are concerned, the presence of lepidopterous pupæ in colonies of ants is not usual, but more or less accidental. At the time of pupation, when the caterpillars leave the food plant, they very often wander into the immediate vicinity or even into the nests of ants which frequently have their colonies located at the roots of the plant. That the pupæ are permitted in the nests of ants is easy to understand on the basis of the symbiotic relationship existing between the caterpillar and the ants. The ants experience the transformation of the caterpillar into the pupa in their very midst, as it were. Very probably their toleration of the pupa is enhanced by the existence of some pleasantly scented substance, secreted by glandular cells situated in its epidermis; at least the action of the ants seems to point in that direction. In none of the lycænid pupæ hitherto known to me is the reason for this tolerance to be sought in the presentation of some kind of gift by the pupa to the ants, because all pupæ of this family so far known are without a secretory organ.

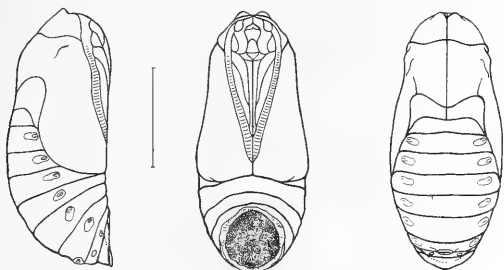

FIGS. 1, 2, 3.—LATERAL, VENTRAL AND DORSAL ASPECTS.

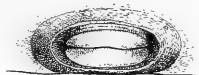

FIG. 4.—MYRMECOPHILOUS ORGAN.

The possession of the organ used in serving the symbiotic relationship appears very strange, in view of the profound histolytic and histogenetic processes during the pupal stage. One might be induced to consider the organ as rudimentary, in a manner similar to the abdominal feet of some caterpillars, indications of which are still visible upon the pupa. A comparison of pupa and caterpillar should then show the development of the secretory organ in the former to be much less than in the latter. The caterpillar producing this pupa is still unknown. A short time ago I received from India caterpillars and pupæ of *Arhopala amantes* Hewits., which show similar relationship when compared from this point of view. The pupæ of this latter species are larger than that under discussion and have also a myrmecophilous organ, though not nearly as well developed. In a comparison between pupa and caterpillar of *A. amantes*, with reference to their myrmecophilous organ it becomes apparent that externally they are exactly alike. As the pupa from the Philippines is much smaller than that from India, though having a much larger and more strongly developed chitinous crater, it can not possibly be assumed that this organ is rudimentary, but it must be considered as being completely functional. This would therefore indicate that the living together of this pupa and the ants is no longer accidental, but has become an obligatory relationship.

The myrmecophilous lycænid caterpillars, as is well known, have, besides the glands for producing honeydew, another organ which has a relation to the symbiosis. On the eighth or penultimate abdominal segment there are two tubes provided with a bristly rim which can be drawn in or extruded like a pair of snail tentacles. In all probability these two epidermal tubes strengthen the symbiosis by attracting ants through the secretion of a scent substance. By no means do the tubes produce any kind of liquid secretion. It is therefore very worthy of note that the tubes in the pupa from the Philippines are entirely rudimentary. They appear only as a pair of slight depressions in the chitin. In concluding that the epidermal tubes are scent organs for attracting ants, it is at once apparent why the tubes and not the secretory organs have become rudimentary in the pupal stage. The attracting of the ants and, therewith, the functioning of the organs serving that purpose, naturally become unnecessary in the ant nest, while the organs which serve in the real symbiosis retain their significance and utility.

To sum up: We have here undoubtedly the peculiar spectacle of a lepidopterous pupa acting as a food purveyor to ants, as it gives them, from a chitinous crater, the secretion of two glands (in analogy with the caterpillars) at least during the first part of the pupal stage.

This singular occurrence induced me first of all again to make a thorough investigation of all lycænid pupæ obtainable. But on none could I discover myrmecophilous organs, and the symbiosis of the Phil-

ippine pupæ with *C. quadrisectus* would therefore have become a very interesting but doubtful case had I not received the aforementioned material from Mr. T. R. Bell, of Karwar, India. The pupæ of *A. amantes* represent, so to speak, the missing link between those lycænid pupæ which are simply permitted to remain, or are more or less accidentally found, in ant nests and those which we may legitimately assign as dwelling in ant colonies.

It would be very interesting to search further for the reciprocal relationship of the symbionts on the spot, chiefly to find out if the butterflies when emerging are not possibly in need of assistance from the ants, as well as to verify the secretion by actual observation. In this wise it would be easier to understand the symbiotic relationship than if the retention of the honeydew glands were credited merely to their use in repaying the ants for the protection afforded the pupæ. For the latter reason no secretory organs such as are demonstrable in many examples, would be needed. As Thomann has demonstrated, the pupæ of palearctic Lycænidæ do not need the help of the ants. This I have been able also to verify on a number of species.

THE POLYSCOPIC CELL. A NEW MICROSCOPICAL ACCESSORY.

By CHARLES S. BANKS.

(From the Entomological Section, Biological Laboratory, Bureau of Science,
Manila, P. I.)

For many years I have found myself handicapped in the study of the anatomy of microscopic animals, especially insects, by having no means whereby parts might be mounted either temporarily or permanently in such manner as to obviate their distortion and at the same time to enable the observer to view them from all sides. Those who have had to study mouth parts, thoracic sclerites and genitalia of minute Coleoptera, Hymenoptera, Lepidoptera and Diptera, will appreciate what I mean when I say that it is next to impossible to get, for example, the proper relationships of the parts of male genitalia in Culicidae in preparations mounted according to the ordinary *modus operandi*.

One needs but to take up any of the more recent publications dealing with mosquitoes in which photomicrographs of the genitalia appear, to be struck immediately by the very unsatisfactory appearance of most of these, owing to displacement of parts, due to pressure of the cover glass in making the preparations.

Furthermore, everyone who has observed the genitalia in living mosquitoes and those recently dead knows that the parts lie in many planes and that no satisfactory idea of their relationships can be secured from a slide which gives only a ventral or a dorsal aspect. It is true that by using a "built-up" cell, this distortion of parts may, to a certain extent, be overcome, but at best it is exceedingly difficult so to mount one of these preparations by ordinary methods as to get a lateral view; and then, if one should succeed in thus mounting the specimen, he must either prepare a second mount showing the dorsal surface and a third one showing the ventral surface, or else reverse the slide, which is not always feasible because of its thickness or of the position of the cover glass.

After having tried every one of the classical cells, as well as numerous others devised by myself, I have at last, I believe, secured a cell which will prove useful not only to the entomologist but likewise to the general biologist.

As the name would suggest, this cell enables the worker to observe all sides of an object parallel to its longitudinal axis, provided this corresponds with the longitudinal axis of the cell itself. For example, in a preparation of the male genitalia of any species of mosquito, if the last three abdominal segments be mounted in this cell, one may obtain both lateral, ventral and dorsal aspects. The only aspect not possible would be the caudal, and this, for anatomical purposes, is quite unnecessary, as all essential features are demonstrable in the other four.

The polyscopic cell, which is really nothing more than a section of glass tubing of small caliber, is made by grinding it to the form of a square prism instead of a cylinder. This, as I shall describe in detail, is easily accomplished in any institution having a rock grinding apparatus; and three or four dozen of these cells can be prepared in a day by the plan which I have adopted.

METHOD OF PREPARATION.

Lengths of glass tubing of small diameter, say 4 to 6 millimeters, and of the required caliber, are cut up into pieces of the desired length, usually 15 to 20 millimeters. It would be better to keep pieces cut from the same tubing together, as these are most likely to have the same caliber and the cells will be kept uniform in this way. Nine to a dozen of these short tubes are fastened to a small plate of glass such as is used in grinding rock specimens.

The best preparation for cementing to the glass is a mixture composed of 20 parts of white shellac and 7 parts Canada balsam. This, in the form of a pencil, is applied to the glass plate held over the gas flame, until a sufficient quantity has melted upon the plate. The short tubes are then placed close together and pressed down upon the plate so that they will all be parallel. (See Plate I, fig. 2.) The cement having become hard, the tubes are ground down upon the steel wheel of a rock-grinding machine, the operator employing first coarse emery and then finer until their surfaces have become worn to the desired degree and have the velvety appearance of ground glass. A still finer polish may be obtained by next grinding for a short time on a plate glass with pumice and water. (See Plate I, fig. 3.)

The next step is to dry the plate and gently heat it until the tubes become loose enough for removal. The entire mass of adherent tubes may be slipped off, turned completely over, pressed firmly to the glass plate to remove air bubbles and, after cooling, the operation of grinding the faces on the opposite side begun. (Plate I, fig. 4.) This being completed, the tubes are now removed as before, set up on edge so that their plane faces are contiguous, recemented to the plate and the third face ground. (Plate I, fig. 5.) For the fourth face, the mass may be slipped off entire and turned over, the same precautions being taken to press the mass flat to the plate. (Plate I, fig. 6.) The finished cells will then appear as in Plate I, fig. 7.

The cells may now be removed from the plate and, after cleaning off the cement, they are ready for use. They may, however, be polished even more finely if it is so desired, to remove the ground surface and render them perfectly transparent like ordinary glass slides; but this is not absolutely necessary, for

the following reasons: After mounting the specimen, the only thing necessary when it is desired to study it under the microscope is to place a drop of immersion oil on the top of the cell and press over it a tiny piece of cover glass. This causes a perfect transparency of the top of the cell and makes the inclosed specimen visible. The only special advantage of having the cell polished is to enable one to determine quickly the position of the specimen within. An advantage of leaving the cell with ground sides is that the number and name of the specimen may be written easily upon the surface with India ink.

METHOD OF USE.

The slide once made (Plate I, fig. 8), the method of preparing and mounting the specimen is a very simple one. Having passed it through all the fluids to the xylene, the portion of the insect which it is desired to preserve is dissected away and placed in the tube of the cell which has previously been filled with Canada balsam dissolved in xylene. The specimen, which should be just large enough to slip into the tube readily, is pushed in by means of a pin or other suitable instrument and the ends of the tube sealed with slide cement of the kind generally used by the worker.

Sometimes it may occur that the specimen is slightly smaller than the caliber of the tube and, in order to hold it in a fixed position therein, recourse may be had to a bent bristle which is pushed in until it comes in contact with the specimen. (Plate I, fig. 9.) A tiny piece of filter paper or other convenient substance will serve the same purpose, as shown in the figure indicated.

Cells of the kind described here may be stored as easily as ordinary microscopical slides by either placing them in a drawer with compartments numbered to correspond with their numbers or else in small envelopes. Where slide cabinets with compartments of sufficient depth are available, an excellent plan is to fasten each cell to an ordinary slide by means of a minute drop of balsam which, while retaining it in place for storage, may be dissolved easily when it is necessary to work with the specimen.

CELL HOLDER.

When using the preparation for study, the cell may be held in place upon a special holder which I have devised for this purpose. It consists of an aluminium plate 25 by 75 millimeters, having an opening 10 by 30 millimeters, in which a small glass slide may rest upon a flange and upon which the cell may be placed and clamped as shown on Plate II, figs. 1 and 2. This piece of apparatus is not necessary if one has slide clips on his microscope long enough to rest upon the ends of the cell, and thus retain it in position for work with the camera lucida or in making photomicrographs.

USES OF THE CELL.

This cell will be found useful not only for minute insects and parts of insects, but it can also be employed to great advantage in the study of Crustacea, Arachnida, Infusoria, Rhizopoda, Vermes, etc. In reality, there is no minimum limit to the size of the cell provided one can obtain glass tubes of small bore. I have cells which have a caliber of less than 0.45 millimeter, and an outside diameter of less than 1 millimeter, thus obtaining a distance of less than 0.625 millimeter between the lower surface of the "Zeiss DD" lens and the floor of the cell tube. The distance between the upper surface of an object lying in a cell of this size and the lens would be small enough to make it possible to examine the object with ease, using a high-power lens.

However, it must be borne in mind that the greater utility of this cell will be in connection with lower power lenses and the camera lucida or the photomicrographic apparatus, and that it serves primarily as a means of preserving parts undistorted by pressure, such as is inevitable in the ordinary technique of flat slide and cover glass, and enables the worker to see successively four sides of the specimen.

ILLUSTRATIONS.

PLATE I.

- FIG. 1. Glass cell cemented to plate and ready for grinding.
FIGS. 2-7. Successive positions in grinding a number of the polyscopic cells.
FIG. 8. The finished polyscopic cell ready for the specimen.
9. The cell with specimen mounted showing means of holding the object in place therein; ready for microscopical examination.

PLATE II.

- FIGS. 1 and 2. Slide devised by the author for holding the cell when microscope is inclined.
FIG. 3. Photomicrograph of ♂ genitalia of *Culex fatigans* Wied., mounted in polyscopic cell, using Zeiss AA objective and No. 3 ocular.
4. Lateral view of same mount, the cell having been given a quarter turn.

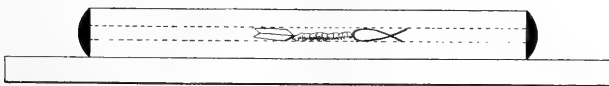
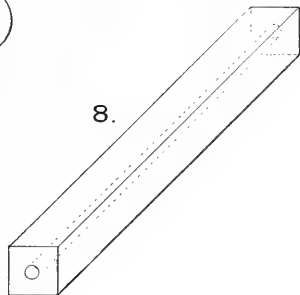
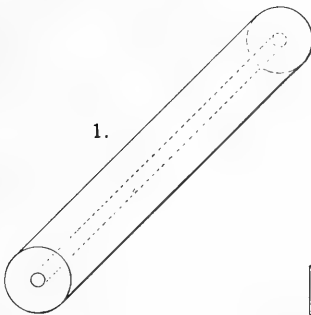
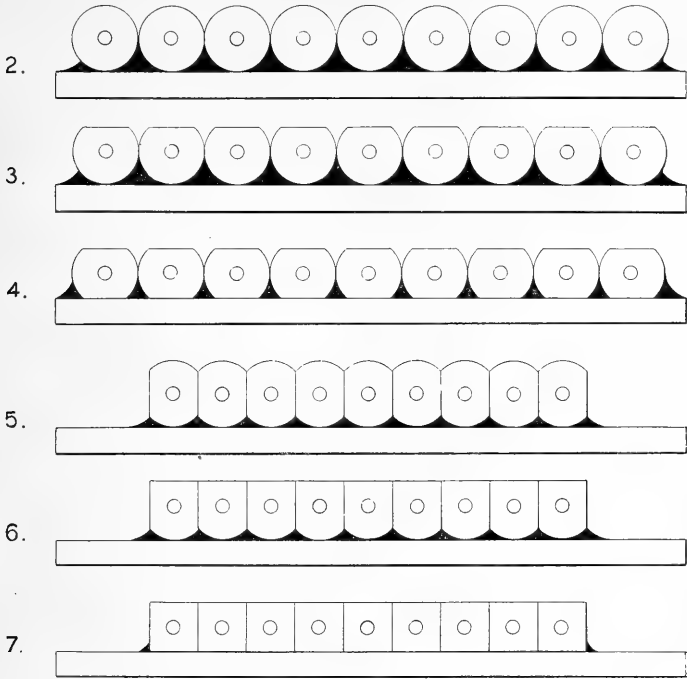

9.

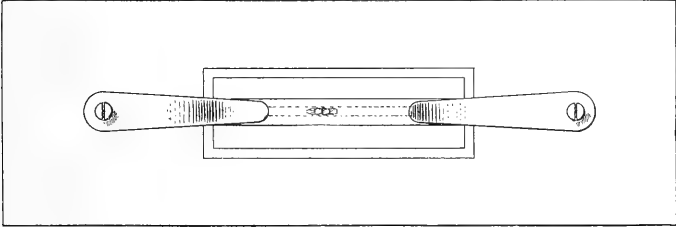

1

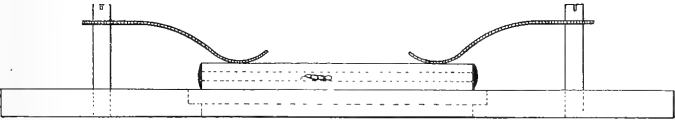

2.



3.



4



EDITORIAL.

AN INTERESTING OCCURRENCE WITH STICKY GRASS: *ERAGROSTIS VISCOSA* TRIN.

While sitting on the veranda at my home several days ago, my attention was attracted by the pitiful wailing peep of a small chicken. I thought at first that it was simply lost and was crying for its mother, but as the wail continued unremittingly for about half an hour, I sent my boy out to find the chick. He returned in a moment bringing a two-day old chicken, still peeping. Upon glancing at it I discovered that three flower stalks of sticky grass were firmly attached to its neck, and two more were twisted in the downy feathers under one wing, the boy in releasing the chick having pulled up the grass.

It required considerable manipulation to disentangle the down of the chick from the grass, but it is quite certain that it could never have freed itself had not help come as it did. In running along, the chick had evidently become enmeshed by a couple of the grass stalks and then, in its efforts to get free, had involved itself to a more serious extent.

An examination of the grass shows that when it is in flower and fruit there exudes from a series of longitudinal pores, beginning from 5 to 10 millimeters below the panicle and extending downward for 10 to 15 millimeters, a viscid substance of great tenacity. This substance serves the plant primarily for protection against ants and other insects which might climb the stalk and damage or remove the flowers or unripe seeds.

As *Eragrostis viscosa* Trin. is very widely distributed in the Philippines as well as in other parts of the Tropics, the possibility of its doing greater damage than would have occurred in this single instance makes its eradication, especially in chicken yards or in other places to which young chickens have access, a problem worthy of consideration.

CHARLES S. BANKS.

A METHOD OF USING MAGNESIUM SULPHATE FOR THE ANÆSTHETIZATION OF MARINE ANIMALS.

While on a collecting trip in the Philippine Islands this spring, I used a method of anæsthetizing marine forms with magnesium sulphate which proved very successful. The method may not be new to many workers, certainly the principle is not. Since I do not know of any zoölogist who uses magnesium sulphate in just this way, I venture to publish the method and hope some one else may find it useful. Success in using magnesium sulphate lies in securing its quick diffusion through the water in sufficient quantity, without causing any mechanical disturbance of the animals to be anæsthetized. If a heap of crystals of the salt is placed on the bottom at one side of a dish of water, solution and diffusion are very slow, and attempts to hasten these processes are apt to result in the contraction of sensitive forms. Some workers have made a large quantity of a saturated solution of the salt, which was then led through a tube to the surface of the dish in which were the animals to be stupefied. I believe this method gives good results; but it is a difficult one to use in ordinary field collecting, where room and apparatus are limited.

The forms on which I have been working this year have been mostly corals, alcyonaria, and gorgonians, with some hydroids and worms. Most of these are quite sensitive. Many of the gorgonians are very slow to expand after they are brought in, and are extremely ready to contract at any time; and I have failed completely in securing well-expanded specimens by the first method mentioned.

The method which I have used successfully is as follows:

A considerable quantity of the magnesium sulphate, say 50 to 250 grams, is tied in a piece of cheese cloth and hung over a dish of water so that the bottom of the bag barely dips into the water. It does not seem to matter whether the bag is directly over or to one side of the specimen to be anæsthetized. Streams of the sulphate solution can be seen descending at once through the water in the dish. Even extremely sensitive zoöids do not seem to be disturbed by the streams of the salt solution. I have sometimes used two bags of the sulphate when a considerable number of specimens were in one large dish. In order to preserve some of the larger specimens, I have anæsthetized them in dishes holding 6 gallons of water. Anæsthesia of some of the alcyonaria can be completed in fifteen minutes, and of most gorgonians in half an hour.

On this same trip I used successfully A. G. Mayer's method of anæsthetizing medusæ by carbon dioxide. The charged water is also helpful in the case of some alcyonarians and gorgonians, although it must be used in conjunction with magnesium sulphate. To other related forms the carbon dioxide is an irritant.

LAWRENCE E. GRIFFIN.

Order No. 401.

THE BONTOC IGOROT.

By A. E. JENKS.

110 pages. 3 maps. 154 photographic plates. 9 figures.

An interesting study; the result of almost a year's residence among the Bontoc Igorots.

Price \$1 United States currency.

Order No. 402.

THE NEGRITOS OF ZAMBALES.

By WILLIAM ALLEN REED.

90 pages. 60 full-page photographic plates. 2 maps. 2 figures.

A valuable ethnological study of the pigmy blacks of Zambales.

Price \$0.25 United States currency, paper; \$0.75 United States currency, half morocco.

Order No. 403.

THE NABALOI DIALECT.

By OTTO SCHEERER.

TOGETHER WITH

THE BATAKS OF PALAWAN.

By EDWARD Y. MILLER.

199 pages. 1 map. 28 full-page photographic plates. 6 figures.

The result of research work among this interesting tribe of primitive people.

Price \$0.25 United States currency, paper; \$0.75 United States currency, half morocco.

Any of the above-mentioned publications may be ordered from the Business Manager, Philippine Journal of Science, Manila, P. I., or from any of the agents listed on the cover of this Journal.

Beginning with Volume V, a new section, "Section D, Ethnology, Anthropology, and General Biology," will be added to the Journal. The price for the whole series to subscribers for 1910 will be as heretofore, \$5 United States currency. Single subscriptions to Section D will be \$2 United States currency.

Beginning with 1911, the price of the entire Journal will be increased to \$7 United States currency. Section D will appear as often as material is available.

CONTENTS.

	Page.
BEAN, ROBERT BENNETT. III. Filipino Types: Racial Anatomy in Taytay. (B.) The Women	1
BEAN, ROBERT BENNETT. Paleolithic Man in the Philippines. Homo Philippinensis	27
BANKS, CHARLES S. Rhynchota Palawanica, Part II: Homoptera	33
DISTANT, W. L. Rhynchota Philippinensia, Part I	57
VIEHMEYER, H. On the Myrmecophily of Caterpillars of Catochrysops Cnejus Fabr.	69
VIEHMEYER, H. A Myrmecophilous Lycænid Chrysalis from the Philippines	73
BANKS, CHARLES S. The Polyscopic Cell	79
EDITORIAL	85

The "Philippine Journal of Science" is issued as follows:

Section A, Chemical and Geological Sciences and the Industries, \$2 United States currency per year.

Section B, Medical Sciences, \$3 United States currency per year.

Section C, Botany, \$2 United States currency per year.

Section D, Ethnology, Anthropology, and General Biology, \$2 United States currency per year.

The entire "Journal," \$5 United States currency for Volumes II, III, IV, and V. Thereafter, \$7 United States currency per year.

Authors receive 100 copies of their papers free.

Subscriptions should be sent to the Business Manager, Philippine Journal of Science, Bureau of Science, Manila, P. I., or to any of the agents listed below. Please give order number.

A limited number of unbound copies of previous volumes are available, which may be secured from the Business Manager, Philippine Journal of Science, Manila, P. I., at the following rates: Volume I, 1906 (not divided into sections), \$10 United States currency; Supplement to Volume I, \$3.50 United States currency; Volume I (without supplement), \$6.50 United States currency; all later volumes at current subscription prices.

Vol. V

JULY, 1910

No. 2

THE PHILIPPINE JOURNAL OF SCIENCE

EDITED BY

PAUL C. FREER, M. D., Ph. D.

WITH THE COÖPERATION OF

DEAN C. WORCESTER, A. B.; ROBERT BENNETT BEAN, M. D.
MERTON L. MILLER, Ph. D.; CHARLES S. BANKS, M. S.
ALVIN SEALE, A. B.; LAWRENCE E. GRIFFIN, Ph. D.
RICHARD C. MCGREGOR, A. B.; NELLIE LOUISE COOK, B. L., M. A.

PUBLISHED BY

THE BUREAU OF SCIENCE

OF THE

GOVERNMENT OF THE PHILIPPINE ISLANDS

D. ETHNOLOGY, ANTHROPOLOGY, AND GENERAL
BIOLOGY

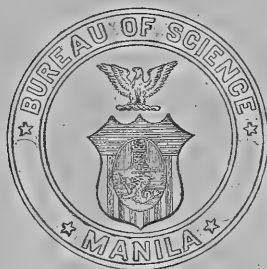

MANILA
BUREAU OF PRINTING
1910

Order No. 405.

STUDIES IN MORO HISTORY, LAW, AND RELIGION.

By NAJEEB M. SALEEBY.

107 pages. 16 illustrations. 5 diagrams.

A treatise on the history and customs of the Moro People.

Price \$0.25, United States currency, postpaid.

THE HISTORY OF SULU.

Order No. 406.

By NAJEEB M. SALEEBY.

275 pages.

A complete History of the Moro People in Sulu, with maps and many translations from the original documents.

Price \$0.75, United States currency, postpaid.

MINDANAO.

Order No. 410.

THE SUBANUNS OF SINDANGAN BAY.

By EMERSON B. CHRISTIE.

122 pages.

Profusely illustrated.

This, together with the History of Sulu and the Studies in Moro History, Law and Religion, is one of an authentic and valuable set of works on the origin, history and customs of these tribes, who are among the most interesting peoples of the world.

Price \$1.25, United States currency, postpaid.

NOTE.

Orders should be sent to the Business Manager, Philippine Journal of Science, Manila, or to any of the below-listed agents. *Please give Order Number.*

FOREIGN AGENTS.

The Macmillan Company, 64-66 Fifth Avenue, New York City, U. S. A.
Messrs. Wm. Wesley & Son, 28 Essex Street, Strand, London, W. C., England.
Mr. Martinus Nijhoff, Nobelstraat 18, The Hague, Holland.
Messrs. Mayer & Muller, Prinz Louis Ferdinandstrasse 2, Berlin, N. W., Germany.
Messrs. Kelley & Walsh, Limited, 32 Raffles Place, Singapore, Straits Settlements.
Messrs. A. M. & J. Ferguson, 19 Baillie Street, Colombo, Ceylon.

CIRCULARS AND DESCRIPTIVE MATTER SENT ON APPLICATION.

THE PHILIPPINE
JOURNAL OF SCIENCE

D. ETHNOLOGY, ANTHROPOLOGY, AND
GENERAL BIOLOGY

VOL. V

JULY, 1910

No. 2

✓ THE FISHERY RESOURCES OF THE PHILIPPINE ISLANDS.
PART III, PEARLS AND PEARL FISHERIES.¹

By ALVIN SEALE.

(From the Section of Fisheries, Biological Laboratory, Bureau of Science, Manila,
P. I.)

INTRODUCTION.

During the past ten years the writer has been engaged, as time would permit, in making a study of pearls and pearl fisheries. In 1900, a year was spent in the fisheries of Paumotu and Gambier Islands and in 1902 the fisheries of Australia and the Solomon Islands were visited; during the past year considerable time was given to a study of the pearling grounds of the Philippine Islands.

So far as possible, a careful study has been made of the development, life history and habits of the pearl oyster, chiefly with the view of increasing its value as a commercial asset. Experiments relating to pearl growth, development and culture have been inaugurated; and a large number of both hard and soft sections through pearls from various localities have been made in order to throw additional light on the direct cause of their origin and growth.

The object of the present paper is to give the results of these observations and a general review of our present knowledge of the subject, with the hope that such results may lead to increased interest in the Philippine pearl fisheries and to their greater development.

¹ Part I of this series appeared in *This Journal* Sec. A (1908), 3, 513; Part II, *Ibid.* (1909), 4, 57.

PHILIPPINE PEARL OYSTERS.

There are two varieties of pearl oysters in the Philippines which are of considerable commercial importance: One, called the gold lip pearl shell, Doctor Pilsbury kindly informs me is doubtless *Margaritifera maxima* Jamson² (see Plate III, figs. 1 and 2); the other, the black lip pearl shell, is *Margaritifera margaritifera* (Linnæus). (See Plate IV, figs. 1 and 2.) The gold lip shell is by far the most important, it being the variety chiefly sought in commercial ventures, its market value being from 30 to 80 pesos³ per picul of 63.3 kilos (139.5 pounds). This shell, when mature, is usually from 180 to 230 millimeters (7 to 9 inches) in diameter and weighs from 1.82 to 2.3 kilograms (4 to 5 pounds); shells weighing more than 5 kilograms (11 pounds) have been found. This species occurs in waters of from 5 to 20 fathoms throughout the Sulu Archipelago, and is probably more or less abundant throughout the entire Philippine group.

The black lip shell is a much smaller variety, rarely exceeding 150 or 180 millimeters (6 or 7 inches), with a weight of from 1 to 1.5 kilograms (2 to 3 pounds), although usually it is much smaller. It is common along the shores of almost all the islands of the Philippine Archipelago, and is of much less value commercially than the gold lip shell, being in but little demand and selling for about 13 pesos per picul. This form usually gives a large yield of pearls which are of comparatively little value, as they generally are small, irregular in shape and of a gray or dusky color.

In the year 1886 a paper was published in Bergen, Norway, which contained the following interesting statement regarding the Philippine pearl fisheries:

The Philippine Islands produce great quantities of pearl shell. In 1877, 155 tons were exported. In 1878, 152 tons, valued at 164,720 pesos were exported. In 1879 the value of exported pearl shell was 155,802 pesos. The entire region from Tawi-Tawi to Basilan is a continuous pearl oyster bed; the Sulu fisheries are the largest and most productive of any in the East Asiatic waters. The pearls are famous, and the shell has a fine luster. Labuan is the chief market. The yield is decreasing.

It will be of interest to compare the above account of the fisheries of thirty years ago with those of the present time. During the year 1907 there were exported from the port of Jolo 154,918 kilos (340,820 pounds) of pearl shell, valued at 119,045 pesos; and during the same period the product exported from Zamboanga was valued at 45,254 pesos, making a total of 164,399 pesos from the Moro Province alone, which shows a substantial increase rather than a decline in the fisheries. The above value

² Revised Nomenclature of Pearl Oysters. *Proc. Zool. Soc. London*, (1901), 1, 392.

³ One peso equals fifty cents U. S. currency.

is of the shell alone; that of the pearls secured during this time is unknown, but doubtless it amounted to several thousand pesos.

No export duty is charged on shell, but wharfage to the amount of 1.50 pesos per ton is collected.

The price of shell at the present time is from 60 to 100 pesos per picul for those of the first class of the gold lip variety, and about 20 pesos per picul for the black lip variety. The picul is counted at 63.3 kilograms (139.5 pounds, 16 piculs to the ton). Almost all the shell is sent either to Singapore or to Europe. There is one button factory located in Manila which has a capacity, when running constantly, of about 6,000 gross per month, requiring about 300 tons of shell per year; otherwise, all the shell is exported.

During the past year about 56 tons of shell were taken from the Davao pearl bed. These were of very large size and first class in every respect. They gave a very small yield of pearls, the value of which was probably not more than 6,000 pesos. Some very beautiful pearls are to be found in the Sulu fisheries, and it was my pleasure to examine two of these, each valued at 5,000 pesos, secured from this region during the past year.

Almost all the fishing for pearl oysters is carried on by the use of diving armor, in water of from 15 to 20 fathoms. Shells are occasionally found in shallower water, but in such cases naked Moros usually dive for them, or they are secured by a primitive rake-dredge worked by a rattan line from a native canoe and which can be used only in smooth water. The natives frequently soak dry shell in water for several days before it is sold, in order to increase the weight; and I have seen Chinese and other middlemen doing the same thing. The shells are usually opened on the boats and all the pearls extracted soon after the oysters are brought up.

THE PEARLING FLEET.⁴

At present about 30 vessels are engaged in pearling in the Sulu Archipelago. These boats range from 5 to 15 tons, and usually carry a crew of seven men, including the diver. All boats with armored divers

⁴The following boats constituted the Zamboanga pearling fleet for the year 1908: *Sirena* and *Nautilus*, owned by J. F. Maddy; *Cleopatra*, *Galatea*, and *Maritima*, owned by J. Wilson; *Ioenia* and *Placido Reyes*, owned by the Cebu Pearling Company; *Mina*, *Burtandy*, *Ida*, and *Manny*, owned by Capt. Chas. Linberg; *Paragua*, *Zamboanga*, and *Sapit*, owned by G. W. Langford; *Alice Holmes*, *Rosario*, and *Olinga*, owned by Mr. Holmes; *Mindanao*, owned by Mr. Teck; *Pruno*, owned by V. Sision. All of these boats carried on more or less active operations during the past year.

The Jolo pearling fleet is composed of the following boats: *Victoria*, *Helena*, *Santa Maria*, and *Elisabet*, owned by Ong Tiam Teng; *Almosouth*, owned by Hadji Abubacal; *King of Spades*, owned by Richard H. Gibbs; *Ramon*, owned by Hernandez & Co.; and *Alfonso* and *Nena*, owned by Asing.

are required to take out a license, for which the charges are 300 pesos a year for a first-class license, or a three months' license may be secured for one-fourth of this amount. These are obtained from the provincial treasurer at Jolo, Zamboanga, or Davao. The divers are usually natives or Japanese. Each boat is equipped with one complete diving outfit, consisting of armor, pump, tubes, weights, etc. The diver receives a wage of from 20 to 80 pesos per month, in addition to a percentage of the shell, but the terms upon which both men and divers are hired vary with almost every pearler.

The treasurer of Davao reports that nine first-class licenses have been taken out at that place since January, 1908, chiefly by local firms, and for the purpose of working the newly opened Davao pearl bed.

It costs about 55 pesos a month, aside from wages, to navigate a pearling boat. The diving armor used is nearly all of a modern type, and of English manufacture. The air pumps used are worked by hand, two men being stationed constantly at the pump when diving is in progress. The diver has from 18 to 20.4 kilos (40 to 50 pounds) of weight attached to him in order to reach the bottom. Divers usually remain under water until they fill the net basket which they carry, this requiring from ten minutes to an hour. The diver of a boat on which I was a guest for some time, usually made about three descents in one hour; this was on the Davao bank in a depth of 20 fathoms and where the man experienced great difficulty in working because of strong currents. The length of time during which an armored diver can remain under water is very indefinite, depending on the depth of water, strength of current, strength of the diver, and other factors. In calm water, but a few feet in depth and of an even temperature, a man should be able to remain for almost an indefinite period. The naked diver scarcely ever stays down for more than one minute. Fishing is carried on at all seasons of the year.

THE PHILIPPINE PEARLING BANKS.

Practically the entire region from Sibutu Passage to Basilan Straits and around the southern shore of Mindanao Island is a continuous potential pearling bank. However, the greater number of the known localities have so constantly been fished that they have had small chance to recover, and, as a result, much of the pearlery's time is lost in prospecting for new beds in various parts of this wide area; but the ground never seems to become completely exhausted, for we found pearling boats operating successfully directly in front of the town of Jolo, within half a mile of the beach. Fishing for shell had doubtless been carried on at this point for over a hundred years.

Occasionally, a pearler will locate a bank on which the oysters are

very abundant. Such a bank was found just south of Basilan Island; another near the Tapu Islands, and another in Tataan Pass of Tawi-Tawi Island. A large yield of shell has been secured near the Samales group. Shell has been reported from Illana Bay, and during the past year an extremely valuable bank was located in the Gulf of Davao in Pakiputan Strait between Samal Island and the mainland. The most prolific portion of the bank was in the narrow part of the passage directly between Point Lanang and Point Linao. The depth of water is from 20 to 25 fathoms. The bank is well protected above by the large reef known as Arboles Island. Usually, there is a very strong current pouring through this strait, but at the point where the pearl bank occurs the tides and currents form a strong eddy which has doubtless contributed to the formation of the bank by giving an opportunity for the spat to settle and attach. The bottom is of coral, sand, and gravel, and is comparatively smooth. The width of the strait at this place is less than 1.6 kilometer (1 mile); the beach on one side slopes steeply down, and on the other drops abruptly into several fathoms of water from a live coral reef. The water is quite clear, its temperature about 24° C., and its specific gravity 1.022. At the time of my visit (May, 1908), there were only four pearling boats operating on this bank; two others were prospecting in adjacent waters.

The currents were so swift that diving could be carried on only between the hours of 6 and 7 o'clock in the morning. The diver, a Filipino, during this hour made three trips to the bottom; on the first he secured three shells; on the second, eight; and on the third, two. These were all large, first-class shells, each weighing about 3.2 kilos (7 pounds). One contained a small pearl.

The diver brought up some young shells for our inspection, and reported that they were abundant on the bed. All the large oysters were in a breeding condition, so probably this bank will be able to keep up a moderate yield, unless overfished at the beginning. So far, the Davao pearl bank has yielded about 56 tons of first-class shell.

Pearl shells in considerable numbers are found in Tañon Strait, between Cebu and Negros Islands; in the vicinity of Guimaras; and also along the west and the north coast of Samar. Shell has also been reported from Palawan and Cagayan Sulu. It is more probable that as the Islands become better known, many new pearling banks will be found, and those now known will be mapped and better defined.

The most desirable bottom for a pearl bank is coarse sand, with dead coral and rock to which the young may attach. They can not grow on live coral, and they are very apt to be covered up and smothered on fine sand.

LIFE HISTORY OF THE PEARL OYSTER.

The oysters are of separate sex, male and female. The eggs of the female, when ripe, are extruded into the sea water, where they are fertilized by the spermatozoa of the male, if by chance the currents bring the two elements together. Doctor Hornell⁵ observed in regard to the Ceylon pearl oyster, "that a ripe female, in close proximity to a mature male, was sufficient cause to excite the male to throw off spermatozoa." The meeting of the spermatozoa and ova is left entirely to chance.

The eggs of the Philippine pearl oyster (*M. maxima* Jamson) are at first pyriform (see fig. 1) and float on the water; as soon as they are

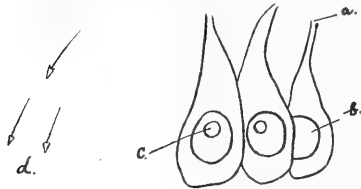

FIG. 1.—Spermatozoa and ova of Philippine pearl oyster.

- (a) Micropyle through which the spermatozoa enters the ova.
 (b) Nucleus.
 (c) Nucleolus.
 (d) Spermatozoa of male.

fertilized, they become round; and when from three to six hours old, they move about by means of small, hair-like cilia. Segmentation is complete, but unequal. The shell begins to form at the end of the second day, and in from four to eight days the young oysters settle and become attached to the bottom, or to any object they chance to fall upon. At this stage they are known as spat and

are about 1 millimeter (0.04 inch) in length. They attach by means of a small tuft of coarse, hair-like bristles, known as the byssus.

Each mature female contains several thousand eggs, but no doubt the destruction of eggs and young is very great, many being swept into great depths by strong currents, where they either perish or settle on the bottom so thickly as to smother each other; or else they become covered with sand, or attach to some floating object and are washed ashore. Apparently, there is no fixed time in the Philippines for the maturing of the ova, as sexually ripe individuals are found at all seasons of the year.

The shells are supposed to reach a maximum size and are most valuable commercially in from four to five years, although they doubtless continue to grow for several years longer. I have examined specimens weighing 5 kilos (11 pounds) which I believe were ten to twelve years old. However, shells older than five or six years are apt to be worm-eaten or full of holes caused by boring sponges, and so are of less value. More

⁵ Report on the operations of the Ceylon pearl banks during the fishery of 1905. *Rep. Ceylon Marine Biol. Lab.* (1906), 55.

accurate information regarding the age and growth of shells obtained from direct observations and measurements is very desirable.

Mr. Seville Kent states in regard to the rate of growth of the pearl oyster:

Under favorable conditions a period not exceeding three years suffices for the shell to attain to the marketable size of 200 to 230 millimeters (8 or 9 inches) in diameter, and heavy shells of 2.3 kilos (5 pounds) weight per pair may be the product of five years growth.

The food of the pearl oyster consists of minute marine infusoria, *Diatomaceæ*, etc. We discovered that in fully 75 per cent of the specimens examined, the food consisted of *Diatomaceæ* with a small amount of vegetable matter.

The pearl oyster does not travel to any great distance; in fact, after the spat stage, it remains in one spot for the greater part of its life, although it can, and does at times, cast off the byssus attachment and reattach to some more desirable place, moving very slowly by means of its small foot. The very old shells of *M. maxima* Jamson were, with but few exceptions, without attachment, probably the weight of the shell being sufficient to keep them in place.

ENEMIES OF THE PEARL OYSTER.

The pearl oyster, especially in its younger stages, is exposed, to constant danger. Numerous fishes consider it a great delicacy, and such fish are found in large numbers about the pearl banks. The various species of sharks, rays, sparoides, and balistes feed largely upon shell fish, including the pearl oyster. However, these are not wholly an evil, as they are probably the intermediate host for the cestode which is the cause of the growth of pearls; the fish becoming infested with this cestode by eating the oyster. Doubtless, star fishes also cause much destruction to the banks, and, in old specimens, the boring sponges, boring worms, and gastropods, do great damage.

In addition to these enemies which affect the oyster directly, there are an enormous number of marine animals and plants that, by using up the available space and food which otherwise would fall to the lot of the pearl oyster, affect the life of the oyster indirectly.

One pearl diver reported the finding of a very large pearl bank south of Basilan Island, where the shells were abundant and of very large size, but of no value, as they were dead and had lost their luster. In cases of this kind, it is almost impossible to state the cause of the destruction. It may have been brought about by some epidemic due to the crowded condition of the shells, or possibly by some volcanic disturbance, or a dozen other causes might be assigned, but without facts it is useless to theorize on the subject.

TRANSPANTING AND CULTIVATING THE PEARL OYSTER.

Pearl oysters may with but little difficulty be transported for several days, if they are kept in running salt water, or if the water is changed frequently; thus the question of transplanting them from one bed to another in a more convenient locality, or in water of less depth, becomes a comparatively simple one and will doubtless play an important part in the pearl oyster industry of the future.

As a matter of fact, the Ceylon government is, or was at a recent date, engaged extensively in the transplanting of young oysters and the distributing of "clutch," i. e., rock of small size which is scattered over the bottom of the oyster beds, and to which the young oysters become attached. The young pearl oysters are removed from beds which are overcrowded to others which are less productive.

It would be an easy matter for men engaged in pearling to keep suspended over the side of their vessels bamboo crates or cars in which they could place the young oysters which are frequently brought up, and so transport them to a favorable place for development, as is the case in the sponge fisheries.⁶ In this way they might, with but little effort, accumulate a valuable pearl farm where a number of oysters could be harvested each year and the bed looked after just as in the case of the edible oyster. The yield of pearls and shell would doubtless pay a good dividend. This process would especially be easy to carry out in the Davao fisheries which are near shore and where local people are engaged in the fishing. Such farms should simulate the natural beds so far as practicable, but improvements over natural conditions could be effected by supplying an abundance of small, broken rock as "clutch," upon which the young could attach; the keeping of the beds free from undesirable tenants, such as star fish, holothurians, etc., could be accomplished by dredging.

LAWS RELATING TO PEARL FISHING.

I have abstracted the laws,⁷ or at least such portions of them not repealed by amendments, as are now in force in the Islands.⁸ They are of undoubted benefit in protecting the young shells, and, for the greater part, relate to the waters of the Moro Province. In other portions of the Archipelago, various local acts and provincial legislation greatly handicap the pearling industry.

⁶ *This Journal*, Sec. A (1909), 4, 62, 63.

⁷ These laws were enacted by the legislative council of the Moro Province. A copy of them may be secured from the provincial treasurer of either Jolo or Zamboanga.

⁸ Sec. 23, Act No. 51, of the Philippine Commission should read: "The words 'pearl shell and shell of the pearl oyster as used in Act No. 43 of the Legislative Council and in this Act shall be construed to mean the shell of the marine bivalve mollusk *Margaritifera maxima* Jamson, commonly known as the Philippine gold lip pearl oyster."

The laws should be extended to include the entire Archipelago, and all local regulations should be repealed. In this way only can the young shell properly be protected. Additional legislation protecting the black lip pearl shell, *Margaritifera margaritifera* (Linnæus), should be enacted.

Act No. 43 provides for the protection of pearl fisheries within the jurisdiction of the Moro Province, and was passed February 29, 1904. It forbids the taking of pearl oysters less than 100 millimeters (4 inches) in diameter.

Act No. 51 regulates the fishing for shells of marine mollusks and was enacted June 7, 1907, at the urgent request of the pearl fishers. It prohibits from engaging in pearl fishing all vessels not built in the Philippine Islands or in the United States, or not wholly owned by citizens of the United States or by people having the political rights of the natives of the Philippine Islands. It prescribes the places at which licenses to engage in pearl fishing may be secured, the price for such licenses, and the length of time for which they are granted. It states that the master of every vessel operating under a first-class license shall record the date of every operation and the number of shells taken each day. Before any shell can be landed, these records must be verified under oath in the presence of the collector of customs of Jolo or Zamboanga. This Act also amends Act No. 43 and requires the size of the shell to be 180 millimeters (7 inches) in diameter from the outer margin to the middle of the hinge, measured at a right angle to the hinge. A fine of not less than 50 pesos is provided for the violation of any provisions of this Act.

Act No. 131 amends Act No. 51 by reducing the price of first-class shell licenses to 300 pesos per annum, and provides for the issuance of such licenses for periods of three months. The enforcement of Act No. 51 resulted in such a decrease of revenues, owing to the excessive cost of licenses, that this amendment was made necessary, and it was enacted August 22, 1905.

Act No. 176 amends section 2 of Act No. 51 and was enacted October 12, 1906. It provides for the issuance of licenses only to those vessels wholly owned by citizens of the United States, to honorably discharged soldiers or sailors of the United States Army and Navy, to natives of the Philippine Islands, or to those having the political rights of natives.

Act No. 200 repeals Act No. 176 and was enacted September 19, 1907, and approved by the Philippine Commission October 7, 1907.

PEARLS.

The Philippine fisheries give a fair yield of pearls; in fact, some of the most beautiful specimens ever discovered have come from the Sulu fishery. The yield is fully as large as that in either the Gambier Islands or the Pearl Islands. The number of pearls secured in Ceylon is much greater. In that country the commercial pearl oyster is of a different species (*Margaritifera vulgaris* Schum.), a very small oyster prolific in pearls, but with shells of practically no value.

The composition of a pure pearl as given by Harley and Harley⁹ is as follows:

Carbonate of lime	91.72
Organic matter	5.94
Water	2.23
Loss	0.11

⁹ The Chemical Composition of Pearls. *Proc. Roy. Soc. London* (1888), 43, 461.

and that of the Ceylon mother-of-pearl, as given by Herdman and Hornell¹⁰ is—

Calcium carbonate	88.79
Calcium sulphate	4.93
Organic matter	2.32
Water	2.28
Loss (no magnesium, no phosphates, faint trace of iron)	1.68

It is well known that the organic basis of the shell, conchiolin, is a cuticular product excreted by the underlying epidermis of the mantle.

Passing without comment the many fanciful theories regarding the formation of pearls which have been held from historic times up to a comparatively recent date, we will consider only such facts as have been revealed by modern scientific investigation.

I have in my work dissected a large number of pearls from our large gold lip pearl oyster (*M. maxima* Jamson). Of this number, forty were prepared as "hard sections," each side being ground down so that a small transparent section through the center of the nucleus was obtained for microscopic examination. (See Plate V, figs. 1 to 3.) Ten were prepared as microtomic sections, and the remainder, and by far the greatest number, were dissolved in acids of various kinds and dissected.



FIG. 2.—Cestode from center of a Philippine pearl.

material that had become calcified and could not be identified with any degree of certainty. Three had what I believe to be the ova of the small

The results show that the round orient Philippine pearl may have various objects in the center forming the so-called nuclei, which, because of stimulation or irritation, have become incased in nacre, thus forming pearls. Fully 50 per cent of the pearls examined contained larval cestodes, two only contained sand, one a bit of seaweed, one a spicule of calcareous sponge, two, forms which with but little doubt were larval Distomids. One rather interesting form (see fig. 2) obtained from a perfectly round pearl appears very closely to resemble the free-swimming larval cestodes secured by Mr. Hornell in Ceylon,¹¹ and is doubtless a related form. Several pearls contained

¹⁰ Report of the government of Ceylon on the pearl fisheries of the Gulf of Manaar. *Roy. Soc. London* (1906), Part V, 6.

¹¹ Hornell & Shipley. Reports on Parasites of the Pearl Oyster. *Rep. Ceylon Pearl Fishery* (1903-1906), Part II, 77; Part III, 49; Part V, 43.

crab (*Alpheus avarus* Fabricius) which is almost without exception found living in pearl oysters as a commensal.

Pearls may be found in any part of the oyster, or in the shell. The free pearls and those attached to the shell result from some injury, while those in the muscles are formed around small, calcareous bodies called calcospherules. The so-called "blisters" on the inside of the pearl shell are usually produced by boring worms or by some external injury. How-

ever, in one case at least, a very fine blister now in my possession was caused by a small black pebble which was completely embedded in the shell. Blisters frequently contain pearls of value, and specimens of good shape and luster may become fully embedded in the shell. I now have a shell before me which, when found, exhibited no sign of a pearl, but when broken, showed two fine pearls, embedded and completely hidden in the shell. (For similar examples see figs. 3 and 4.)

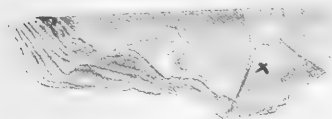

FIG. 3.

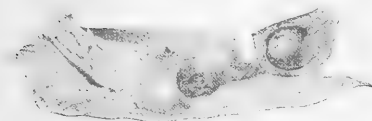

FIG. 4.

A bit of shell in which a pearl valued at 500 pesos was hidden. The X, fig. 3, shows where the pearl was located. Fig. 4 is the same shell cracked open, showing the pearl.

Cyst pearls are found in the mantle or soft parts of the oyster. These are formed by a larva, usually a cestode, which enters some portion of the connective tissue where, as stated by Doctor Jamson,¹² it at first occupies a space lined with connective tissue fiber; but the oyster soon gives rise to a pearl-secreting, epithelial layer which lines this space and becomes the pearl sac. I am of the opinion held by Mr. Herdman and Mr. Hornell¹³ that this pearl-secreting epithelium is of ectodermal origin.

ARTIFICIAL PRODUCTION OF PEARLS.

From the time of Linnæus, who claimed to have discovered a method whereby the oyster could be made to produce pearls, up to the present date, the attempt to force the passive oyster into producing culture pearls has never ceased, so that almost each year some one announces in the press of the country that he has at last reached the true solution of the problem and can produce pearls at will. There is no question but that,

¹² The Formation of Pearls in European Mussels by Action of Trematodes. *Proc. Zool. Soc. London* (1902), 140.

¹³ Notes on Pearl Formation in the Ceylon Pearl Oyster. *Rep. Brit. Assoc.* (1903), 695.

in some cases at least, cultural pearls have been produced; but when the methods have been brought to the crucial test there is always some small point or flaw which has prevented their application with profitable results. This is at least true concerning the forming of the free, round, cyst pearls of fine luster, but in so far as the production of half-pearls and blisters is concerned, the Mikimoto pearl farm in the Bay of Ago, Japan, need only be visited to carry conviction that the artificial production of pearls is both practicable and profitable, for at this place several hundred people are employed in the work, and the cultural pearls harvested find a ready market at a good price. In fact some of the "antique" jewelry sold in Manila was found to be set with these. (See photograph of some of these culture pearls, natural size, Plate VI, fig. 1.)

From 200,000 to 300,000 oysters are treated each year at this pearl farm. The method employed is similar in most respects to that used by the Chinese hundreds of years ago, when small, rough images of Buddha were placed between the mantle and shell of the live river clam, which was then returned to the water until the images were coated over with nacre, after which they were taken out and sold as charms. The Japanese use a small canula to insert a minute mother-of-pearl bead which is flat on the side and which fits against the shell. The oyster is then again placed in the water and allowed to grow for six or seven years, when the pearls are harvested. The undertaking is profitable, owing to the large number of oysters treated.

However, the chief object to be desired is to grow round, perfect, cultural pearls of fine luster; in other words, to produce a cyst pearl, or one so closely resembling it as to be indistinguishable from it. Our efforts have been directed to this end, but the results so far obtained do not warrant publication. As an illustration of some of the difficulties encountered by those engaged in experimenting in pearl growing, a gentleman from Australia, who some time ago purchased the experimental pearl farm inaugurated at Tuesday Island by Seville Kent, and who had spent several thousand pounds in attempting to grow cultural pearls, remarked to me, "I have succeeded in growing the perfectly round pearls, but my great difficulty is to prevent their discoloration."

It may be predicted that within the next few years perfectly round cultural pearls of fine luster will be produced commercially and that the undertaking will prove to be the most profitable achievement of modern zoölogy.

Pearls of value sometimes are found in other mollusks of the Philippines, as, for instance, in the Taclobo (*Tridacna gigas* Linn.) which occasionally contains pearls of great beauty. (See Plate VI, fig. 2.) However, these usually are without luster and hence valueless.

DETERMINATION AND VALUATION OF PEARLS.

Pearls have a hardness of 4, they are so compact that they do not break when stepped upon; their specific gravity is 2.65 to 2.68. To be of much value they must be round or drop-shaped and either pure white, or dark, or of a golden color, with a peculiar luster and slight translucency. They must be free from spot, speck, or blemish. As they are formed, layer upon layer, around a central point, like the layers of an onion, they are sometimes peeled or "doctored" to remove spots or flaws, in the hope that the new layer will be of better luster. Such pearls are obviously of much less value than those found perfect, in their natural condition. However, any such tampering with a pearl can usually be detected by the use of a good glass, which shows any minute band-like stripes or slight scratches. It is also a very easy matter to detect whether a trifle more than one layer of a pearl has been taken off, and equally as easy to tell the difference between a pearl that has been ground into a round shape and one naturally round; such specimens are of but little greater value than marbles. The following is a table of the actual size of pearls of from 0.1296 to 1.944 grams (2 to 30 grains).



















Grains.		Grains.		Carats.
2		3		$\frac{1}{2}$
4		5		$\frac{2}{3}$
6		7		1
8		9		$\frac{1}{4}$
10		11		$\frac{1}{2}$
13		14		2
15		16		$2\frac{1}{4}$
17		18		$2\frac{1}{2}$
20		22		3
25		30		4

FIG. 5.—Exact sizes of pearls from 2 to 30 grains in weight.

No one but an experienced buyer can properly estimate the value of a pearl, as many conditions, such as size, shape, luster, flaws, etc., must be taken into consideration. In 1896 a very interesting publication was issued by the United States Government,¹⁴ giving the value of pearls all over the world, together with an estimate of the yield. In Manila, a perfect pearl of 0.0643 gram (1 grain) with good luster and shape retails for about 5 pesos. The price increases more rapidly than the size of the pearl, as from 70 to 100 pesos per 0.205 gram (1 carat) is asked for perfect pearls over 0.41 gram (2 carats) in weight.

¹⁴ Pearl Fisheries and Pearl Supply. *U. S. Consular Report*. (1896), 51, 622.

ILLUSTRATIONS.

PLATE I.

Landing pearl shell at Jolo.

PLATE II.

- FIG. 1. Jolo pearling fleet.
2. Pearl diver in the water.
3. Pearl diver coming out of the water.

PLATE III.

Philippine gold lip pearl shell (*Margaritifera maxima* Jamson).

- FIG. 1. Inside view.
2. Outside view.

PLATE IV.

Philippine black lip pearl shell (*Margaritifera margaritifera* Linnæus).

- FIG. 1. Inside view.
2. Outside view.

PLATE V.

- FIG. 1. Section through center of Philippine pearl, showing an encysted cestode.
2. Section through a Philippine pearl, showing a calcified cestode in the center.
3. Section through a Philippine pearl which had a grain of sand in the center. It is also shown how a perfectly round pearl may become irregular and how it may be peeled to form a perfectly round pearl.

PLATE VI.

- FIG. 1. Culture pearls from the pearl farm in the Bay of Ago, Japan.
2. Pearls, found at Siasi Island in Tacloban shells.

TEXT FIGURES.

- FIG. 1. Spermatozoa and ova of Philippine pearl oyster.
(a) Micropyle, through which the spermatozoa enters the ova.
(b) Nucleus.
(c) Nucleolus.
(d) Spermatozoa of male.
2. Cestode from center of a Philippine pearl.
3. A bit of shell in which a pearl valued at 500 pesos was hidden. The *x* indicates the spot where the pearl was hidden.
4. The same shell as in fig. 3, but cracked open showing the pearl.
5. Exact sizes of pearls from 0.1296 to 1.944 grams (2 to 30 grains) in weight.



LANDING PEARL SHELL AT JOLO.
PLATE I.

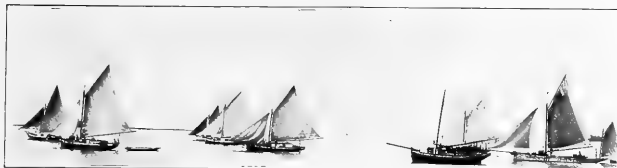

FIG. 1.



FIG. 2.

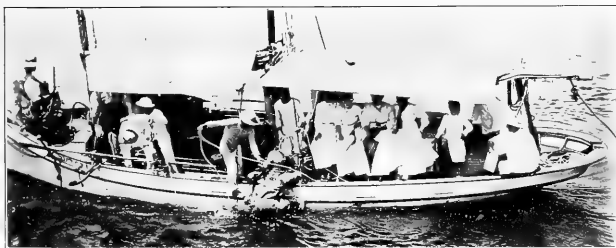

FIG. 3.

PLATE II.

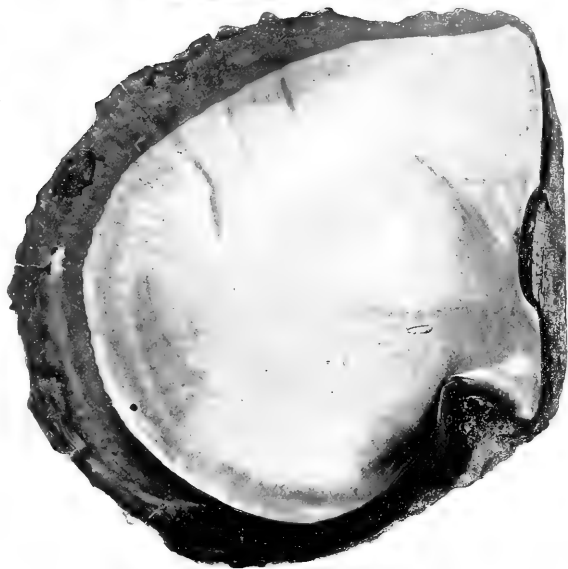

FIG. 1.

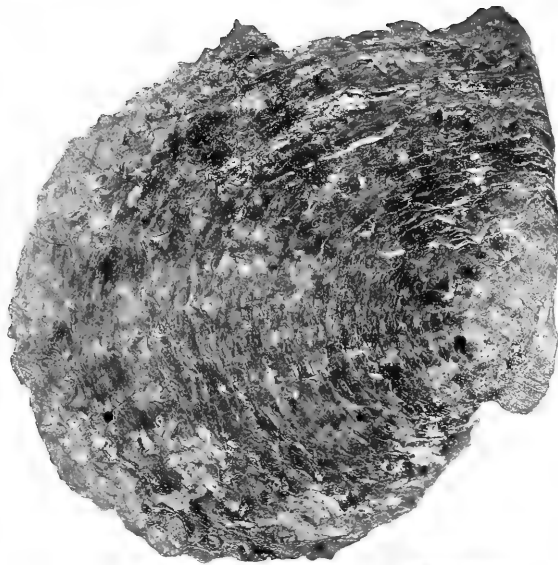

FIG. 2.

PHILIPPINE GOLD LIP PEARL SHELL (*MARGARITIFERA MAXIMA* JAMISON).

PLATE III.

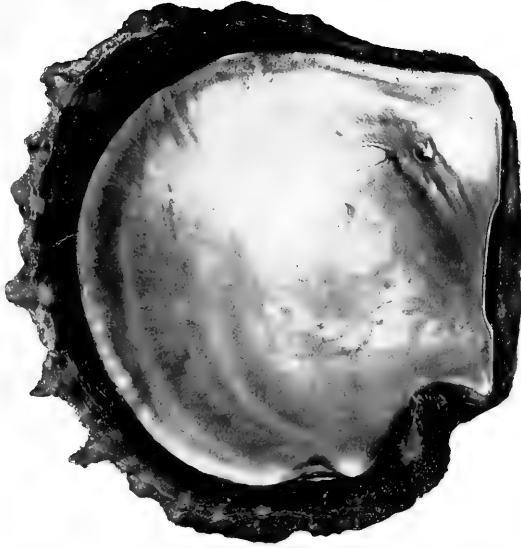
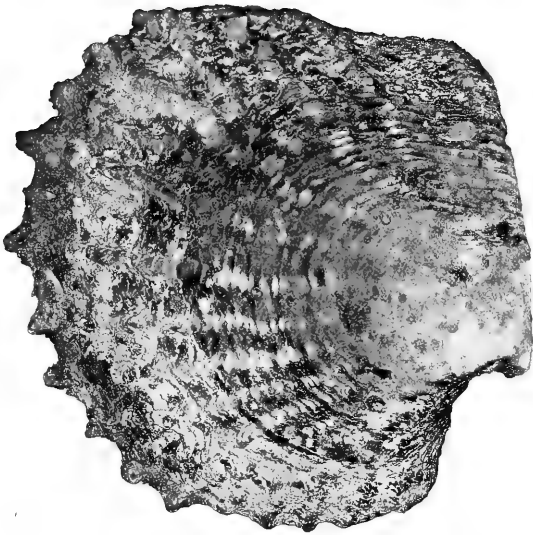

FIG. 1. PHILIPPINE BLACK LIP PEARL SHELL (*MARGARITIFERA MARGARITIFERA* LINNAEUS).
PLATE IV.

FIG. 2.

1
2
3
4
5
6
7
8
9
10
11
12
13
14
15
16
17
18
19
20
21
22
23
24
25
26
27
28
29
30
31
32
33
34
35
36
37
38
39
40
41
42
43
44
45
46
47
48
49
50
51
52
53
54
55
56
57
58
59
60
61
62
63
64
65
66
67
68
69
70
71
72
73
74
75
76
77
78
79
80
81
82
83
84
85
86
87
88
89
90
91
92
93
94
95
96
97
98
99
100

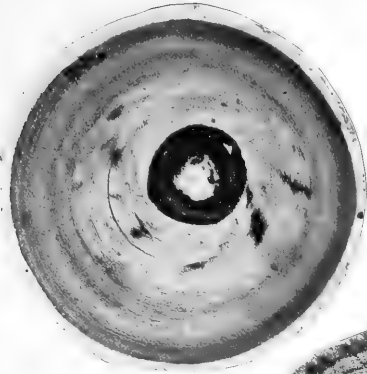

FIG. 1.

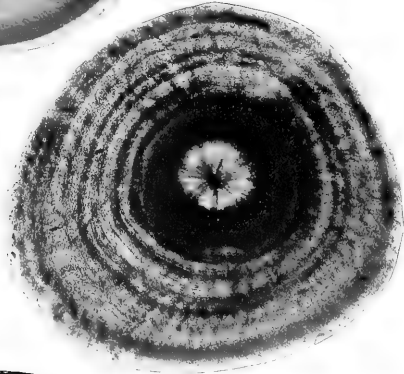

FIG. 2.

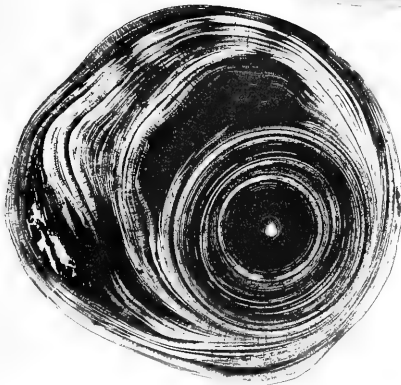

FIG. 3.

PLATE V.

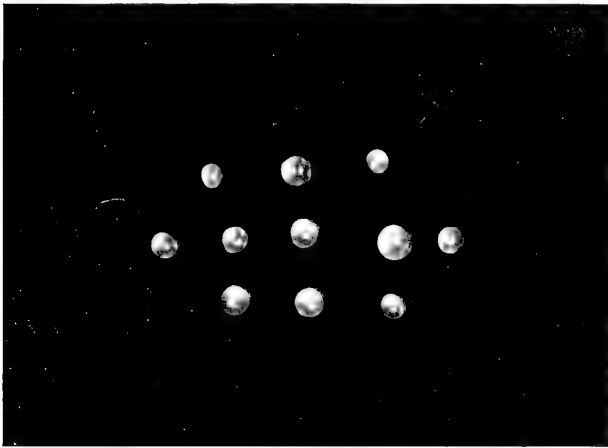

FIG. 1.

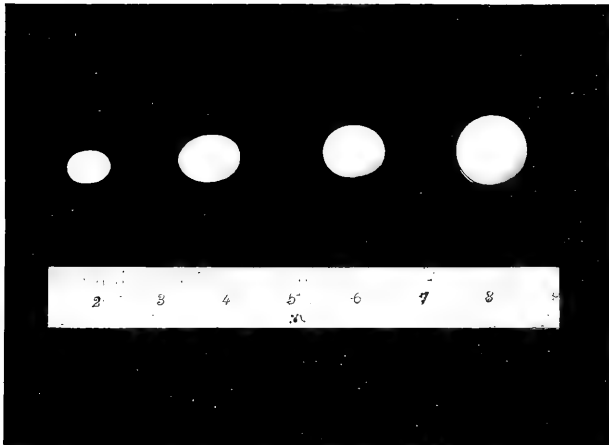

FIG. 2.



BIRDS COLLECTED IN THE ISLAND OF POLILLO,
PHILIPPINE ISLANDS.

By RICHARD C. MCGREGOR.

(From the Ornithological Section, Biological Laboratory, Bureau of Science,
Manila, P. I.)

INTRODUCTION.

The Island of Polillo is situated some 36 kilometers from the nearest coast of Luzon in about the same latitude as Manila. Its area is roughly 900 square kilometers and its length, north and south, 56 kilometers. Although nearly the entire island is mountainous, no part of the surface has a great elevation, the highest point, Mount Malulud in the north-central part, being but 350 meters. With the exception of a few small areas planted in rice, mostly along the western coast, Polillo is heavily forested. No grass land was discovered and in no island have I seen so large a proportion of the area covered with trees.

In May, 1907, Mr. H. M. Ickis brought me a specimen of *Collocalia marginata* with nests and eggs which he had collected near the settlement of Burdeos on the eastern side of Polillo. Beyond this nothing has been known concerning the fauna of the island.

In September, 1909, with two Filipino assistants, I was landed at the town of Polillo and for two and one-half months we made collections of birds, insects, reptiles, mollusks, and plants.¹ The greater part of our collecting was done in the vicinity of the town and along the coast north and south of the town; a little time was spent near Burdeos. The birds collected, or certainly identified, number 101 species, of which I venture to describe the following as new: *Tanygnathus freeeri*, *Penelopides subnigra* and *Kittacincla parvimaculata*.

Rejecting migrants and other species of wide distribution, we find that Polillo has more in common with Luzon than has Marinduque, Catanduanes, Lubang, or the Babuyanes. Of the seventeen species found

¹Dr. C. B. Robinson of the Bureau of Science visited Polillo during August, 1909, and he will publish in the botanical section of *This Journal* a paper on the plants collected by him and by my party.

in Luzon, but not known from Mindoro, Masbate, Samar, nor any of the other more southern islands, we find ten in Polillo, nine in Marinduque, five in Catanduanes, one in Lubang, and one in the Babuyanes. This is most clearly shown in tabular form.

List of species of birds confined to Luzon and smaller adjacent islands.

Species.	Luzon.	Polillo.	Marin- duque.	Catan- duanes.	Lubang.	Babu- yanes.
<i>Leucotreron marchei</i>	×	>				
<i>Phleganus luzonica</i>						
<i>Prioniturus luzonensis</i>						
<i>Loriculus philippineis</i>						
<i>Ceyx melanura</i>	×					
<i>Hydrocorax hydrocorax</i>						
<i>Penelopides manilla</i>						
<i>Centropus viridifus</i>						
<i>Dasylophus superciliosus</i>						
<i>Lepidogrammus cumingi</i>						
<i>Cryocolaptes hamatrimon</i>						
<i>Lichtensteinipicus funebris</i>						
<i>Artamides striatus</i>						
<i>Irena cyanogastra</i>						
<i>Kittarivinda luzonensis</i>						
<i>Cinnyris henkei</i>						
<i>Cinnyris flaucus</i>						
Totals	17	10	9	5	1	1

In Polillo, as in nearly all of the smaller islands, several of the genera which are most conspicuous in the large islands are not represented. Not one species of any of the following genera was found in Polillo:

<i>Caprimulgus.</i>	<i>Pycnonotus.</i>	<i>Hyloterpe.</i>
<i>Hemiprocne.</i>	<i>Copsychus.</i>	<i>Pardaliparus.</i>
<i>Cacomantis.</i>	<i>Orthotomus.</i>	<i>Callisitta.</i>
<i>Xantholama.</i>	<i>Cisticola.</i>	<i>Zosterops.</i>
<i>Pitta.</i>	<i>Megalurus.</i>	<i>Anthreptes.</i>

LIST OF BIRDS.

MEGALOPIDIIDÆ.

Megapodius cumingi Dillwyn.

Apparently very rare; two fresh eggs were purchased, September 27.

PHASIANIDÆ.

Gallus gallus (Linnaeus).

The only specimen of the jungle fowl seen in Polillo was a female which had been caught in a trap.

TRERONIDÆ.

Osmotreron axillaris (Bonaparte).

This little pigeon was very abundant in thickets bordering the forest; it was frequently noticed feeding on the fruits of *Pandanus copelandi* Merrill. Name in Polillo, "punai."

Phapitreron amethystina Bonaparte.

The amethystine brown pigeon is known in Polillo as "cu-lu-cu-lu." It was usually killed in fruiting trees of various species of *Ficus* § *Urostigma*, but when not found in these trees it was rarely seen. Specimens from Polillo, Luzon, and Bohol appear to be identical in size and coloration.

Leucotreron marchei (Oustalet).

On October 19 a female fruit pigeon, presumably *L. marchei*, was killed from a tree in deep forest. The plumage agrees in many points with Grant's description of the young male,² but for the present this identification must be considered provisional.

Muscadivores chalybura (Bonaparte).

This "balud," or imperial pigeon, was fairly abundant until a typhoon swept the island during the night of October 24. After that date not a bird of this species was heard. Possibly they moved to a part of the island where the trees were less damaged. September 14 a male bird was shot from a nest containing a single, heavily incubated egg. The nest had been built in a large tree at a height of about 10 meters. The egg is pure white and measures 46.5 by 32.3 millimeters.

I recently have seen two living examples of a pigeon from Bulacan Province, Luzon. I have no doubt these were *M. nuchalis* (Cabanis). This is a very distinct species with a large, well-defined patch of dark chestnut on the neck. A note on this species will be published as soon as specimens can be collected and compared with other material.

Myristicivora bicolor (Scopoli).

Early in October the nutmeg pigeon was found in some numbers near the barrio of Burdeos on the east coast, and specimens were collected at a later date near the town of Polillo.

COLUMBIDÆ.

Macropygia tenuirostris Bonaparte.

One male and one female were collected; the species seemed to be rare.

² *Ibis* (1895), 469.

PERISTERIDÆ.

Streptopelia dussumieri (Temminck).

This common species was usually found near the beach.

Chalcophaps indica (Linnaeus).

This widely distributed dove is known in Polillo by the name "u-man-ban."

Phlegoenas luzonica (Scopoli).

A male in molt, collected October 31, does not differ from typical specimens. This species is known in Polillo as "la-ga-ran."

RALLIDÆ.

Hypotænidia torquata (Linnaeus).

A living, immature female was purchased September 24 and another was seen at a later date.

LARIDÆ.

Sterna sinensis Gmelin.

Two pairs of this little tern were killed September 7; the species was not noted again.

CHARADRIIDÆ.

Arenaria interpres (Linnaeus).

Two females were killed October 6 and others were seen subsequently.

Squatarola squatarola (Linnaeus).

Fairly common on tide flats and sandy beaches during October and November.

Charadrius fulvus Gmelin.

Two males in molt were taken, September 7 and 15, respectively.

Ochthodromus geoffroyi (Wagler).

Two females and one male were collected September 7 and one female November 4.

Ochthodromus mongolus (Pallas).

Four females were killed from a large flock on November 17.

Ægialitis dubia (Scopoli).

One male and one female.

Ægialitis peroni (Bonaparte).

One male was collected November 12.

Ægialitis alexandrina (Linnaeus).

One female killed November 8.

Numenius variegatus (Scopoli).

Not abundant; a male was collected September 11.

Totanus eurhinus (Oberholser).

One female was collected October 1.

Helodromas ochropus (Linnæus).

One female was collected November 11.

Heteractitis brevipes (Vieillot).

The Polynesian tattler was one of the most abundant beach-birds; a specimen in mottled plumage was killed September 7.

Actitis hypoleucos (Linnæus).

Fairly abundant.

Glottis nebularius (Gunnerus).

One female was killed from a flock November 3.

Rhyacophilus glareola (Linnæus).

Three females were collected November 11.

Calidris leucophæa (Pallas).

One male was collected November 4.

Pisobia ruficollis (Pallas).

One female was collected November 4.

Gallinago megala Swinhoe.

Abundant during October and November; the native name is "u-suc-u-suc."

CEDICNEMIDÆ.**Orthorhamphus magnirostris** (Vieillot).

One male, collected September 13, was the only individual seen on the island.

CICONIIDÆ.**Dissoura episcopus** (Boddaert).

This species is known as "a-mo-bú" on Polillo; individuals were seen from time to time, but not one was killed.

ARDEIDÆ.**Egretta garzetta** (Linnæus).

Two specimens were collected.

Demigretta sacra (Gmelin).

Rare; one or two seen.

Nycticorax manillensis Vigors.

A few individuals seen in trees along small streams.

Butorides javanica (Horsfield).

Abundant.

Bubulcus coromandus (Boddaert).

Abundant in fields wherever carabaos were feeding.

Nannocnus eurhythmus (Swinhoe).

Two males were collected, September 30 and October 13, respectively.

ANATIDÆ.

Anas luzonica Fraser.

This mallard is known in Polillo as "pá-pan."

Spatula clypeata (Linnaeus).

Three shoveler ducks were killed November 1; this species is called "ba-li-uis."

FALCONIDÆ.

Astur trivirgatus (Temminck).

One immature male was collected September 26.

Accipiter gularis (Temminck and Schlegel).

An immature female was collected November 17.

Spilornis holospilus (Vigors).

One male was killed near the barrio of Burdeos.

Butastur indicus (Gmelin).

A few individuals noted.

Haliastur intermedius Gurney.

Occasionally seen.

Pernis ptilorhyncus (Temminck). *

A female honey buzzard, taken September 30, is in immature plumage. Entire under parts white, lightly washed with buff; feathers of throat and fore breast with blackish shafts; forehead, cheeks, ear-coverts, and a wide band over each eye white; a large patch in front of each eye, and a smaller space behind each eye, blackish brown. Another female, in adult plumage, was collected October 2.

STRIGIDÆ.

Ninox philippensis Bonaparte.

One female was killed in deep forest; others were heard in coconut trees about the town.

CACATUIDÆ.

Cacatua hæmaturophygia (P. L. S. Müller).

Several hundred cockatoos roosted every night in a large, dead tree in the center of a rice field. This species is called "ca-lang-ai" in Polillo.

PSITTACIDÆ.

Tanygnathus lucionensis (Linnaeus).

Abundant.

Tanygnathus freeri sp. nov.

Specific characters.—Similar to *Tanygnathus everetti* Tweeddale, but much larger; wings and tail much longer; blue of the back lighter; green of the crown lighter; a distinct yellow collar on the hind neck.

Type.—No. 7219, adult male, Bureau of Science collection; collected near Polillo, Island of Polillo, November 8, 1909, by R. C. McGregor and

A. Celestino. Length, about 400 millimeters; wing, 235; tail, 170; chord of culmen from front of cere, 37; bill from nostril, 36; tarsus, 18. Upper mandible bright red, light yellow near the tip; lower mandible light orange-yellow; feet black.

Description.—Top and sides of head green; hind neck, sides of neck, chin, and throat golden-yellow, the yellow collar being quite distinct from the green occiput; interscapulars dark green, edged with blue; entire back and rump blue; tail-coverts green; rectrices green above, the tips narrowly golden-yellow, shafts black, below golden-yellow, shafts gray; exposed portions of wing-feathers green, shafts black, and more or less of the inner webs black; first primary with the entire inner web as well as much of the outer web black; median and greater secondary-coverts conspicuously edged with golden-yellow; below, wing-quills and greater under wing-coverts slate-black, very narrowly edged with yellow; lesser coverts, axillars, abdomen, flanks, and thighs green.

Female.—No. 7175, Polillo, Island of Polillo, October 21, 1909. McGregor and Celestino. The female is similar to the male. Length, 400 millimeters; wing, 230; tail, 165; chord of culmen from anterior margin of cere, 35; bill from nostril, 35; tarsus, 20. Bill white; iris bright red; legs and feet dirty, pale blue; nails horn-gray.

Freer's parrot was not detected until after the typhoon of October 24 and then it was found feeding in "camansi" (*Artocarpus camansi* Blanco) and "catmon" (*Dillenia philippinensis* Rolfe). The individuals observed by us were silent, thus presenting a marked contrast to the noisy Philippine green parrot, *T. lucionensis* (Linnæus). This species is named for Dr. Paul C. Freer, director of the Bureau of Science, Manila.

Loriculus philippensis (P. L. S. Müller).

Our efforts to secure specimens of this species met with little success. Of the two males collected, one only has the red plastron on the breast. This specimen resembles *L. philippensis* of Luzon, except that there is no trace of orange behind the red forehead; this, if constant, would be a perfectly good specific character, but as it may be due to immaturity, I shall not attempt to found a species upon it.

CORACIIDÆ.

Eurystomus orientalis (Linnæus).

Rare.

ALCEDINIDÆ.

Pelargopsis gigantea Walden.

Fairly common; one would expect to find *P. gouldi* Sharpe in Polillo, but a male *Pelargopsis*, collected October 2, is certainly *P. gigantea*, the light-colored species.

Alcedo bengalensis Gmelin.

Fairly abundant.

Alcyone cyanopectus (Lafresneye).

Four males and one female from Polillo do not differ from Mindoro and Masbate skins of this species.

Ceyx melanura Kaup.

Two males and two females are easily distinguishable from *C. mindanensis* Steere by their smaller size and much shorter bills.

Halcyon gularis (Kuhl).

One immature female was preserved.

Halcyon chloris (Boddaert).

One female was collected.

BUCEROTIDÆ.

Penelopides subnigra sp. nov.

Specific characters.—Most nearly allied to *Penelopides manilla* (Boddaert), but noticeably larger with longer bill, wings, and tail. Back, rump, tail-coverts, and wings black, glossed with dark green, instead of being dark brown.

Type.—No. 7038, adult male, Bureau of Science collection. Collected near Polillo, Island of Polillo, September 19, 1909, by R. C. McGregor and A. Celestino. Wing, 260 millimeters; tail, 235; bill from nostril, 93.

The female is almost entirely black, thus resembling the females of *P. affinis* Tweeddale and *P. basilanica* Steere, but the rufous on the rectrices is confined to a small area near the middle of the tail as in *P. manilla* (Boddaert).

This hornbill is abundant in Polillo; it was often found feeding on the fruit of a species of *Ficus* § *Urostigma* and on the fruit of a tree belonging to the genus *Dysoxylum*.

MICROPODIDÆ.

Collocalia marginata Salvadori.

Salvadori's swiftlet was abundant in and near the town of Polillo and was found nesting in a small cave near Burdeos; nests containing young birds were examined October 5.

Tachornis pallidior McGregor.

This palm swift was noticed only in the town of Polillo. Specimens of this species and of *Collocalia marginata* were knocked down with bamboo poles in front of our house.

TROGONIDÆ.

Pyrotrogon ardens (Temminck).

Fairly abundant in deep forest; one male was collected.

CUCULIDÆ.

Centropus unirufus (Cabanis and Heine).

Six specimens from Polillo are darker in color than one specimen from Bataan Province, Luzon. The species is abundant in Polillo.

Centropus viridis (Scopoli).

Rare.

Dasylophus superciliosus (Cuvier).

Abundant.

PICIDÆ.

Chrysocolaptes hæmatribon (Wagler).

Fairly abundant; two females were collected.

Lichtensteinipicus funebris (Valenciennes).

Very rare; one male was collected.

HIRUNDINIDÆ.

Hirundo gutturalis Scopoli.

Two immature males were collected in September.

MUSCICAPULIDÆ.

Hemichelidon griseosticta Swinhoe.

Rare; one female September 29.

Cyornis philippinensis Sharpe.

Abundant; in one male, collected September 4, the flanks and basal tail-coverts are washed with reddish orange, thus approaching *Cyornis mindorensis* Mearns.

Hypothymis occipitalis (Vigors).

Abundant; one male was collected.

Rhipidura nigritorquis Vigors.

Abundant; one young male was collected.

Xeocephus rufus (Gray).

Two males and one female.

CAMPOPHAGIDÆ.

Artamides striatus (Boddaert).

Fairly abundant; specimens from Polillo do not differ from others taken in Luzon.

Pericrocotus cinereus Lafresneye.

One specimen was killed November 1; others were seen a few days earlier.

Lalage niger (Forster).

Fairly abundant.

PYCNONOTIDÆ.

Irena cyanogastra Vigors.

Abundant; many specimens were collected and do not differ from others from Luzon.

Iole gularis (Pucheran).

This fruit thrush fed in great numbers at a species of *Ficus* of the section *Urostigma*. Other birds feeding on the fruit of the same tree were: *Ircna*, *Phapitreron*, *Poliolophus*, and *Penelopides*. In Polillo the fruit thrush is known as "tu-tu-riác."

Poliolophus urostictus (Salvadori).

A very common species.

TURDIDÆ.

Petrophila manillensis (J. R. Forster).

First seen on September 22 when a male was killed.

Kittacincla parvimaculata sp. nov.

Specific characters.—Similar to *Kittacincla luzoniensis* (Kittlitz), but the terminal white spots on the rectrices much shorter. On the outermost pair the spots are 7 to 8 millimeters, when measured on the shafts (in *K. luzoniensis*, 13 millimeters); on the second pair, about 7 millimeters (in *K. luzoniensis*, 13 millimeters); a trace, or no white, on the third pair; no white on the fourth pair. In *K. luzoniensis* the white spots are always well developed on three, usually on four, pairs of outer rectrices. White superciliary stripes about as wide as in *K. luzoniensis*, but not united across the forehead in any of the eleven males from Polillo.

Type.—No. 7151, adult male, Bureau of Science collection; collected in Polillo, October 15, 1909, by R. C. McGregor and A. Celestino. Wing, 76 millimeters; tail, 77; culmen from base, 18.5; tarsus, 25.

SYLVIIDÆ.

Acanthopneuste borealis (Blasius).

Rare.

ARTAMIDÆ.

Artamus leucorhynchus (Linnæus).

Abundant; native name, "man-da-ra-gít."

LANIIDÆ.

Otomela lucionensis (Linnæus).

A female, collected October 30, is probably *O. lucionensis*, but two males, collected October 2 and September 23, respectively, seem to be much nearer *O. cristata*.

DICÆIDÆ.

Dicæum xanthopygium Tweeddale.

A very abundant species, indistinguishable from Mindoro specimens. This flowerpecker feeds at the flowers of *Conocephalus violaceus* (Blanco) Merrill and also at the fruit of *Ficus minahassæ* Miquel.

Dicæum pygmæum (Kittlitz).

Two females were collected.

NECTARINIIDÆ.

Æthopyga flavipectus Grant.

Grant's sunbird was found in abundance. Immature males were taken throughout September, and three males, collected late in October, show gray on the sides of the throat.

Cinnyris sperata (Linnæus).

Fairly abundant.

Cinnyris jugularis (Linnæus).

Abundant in mangrove-swamps.

MOTACILLIDÆ.

Motacilla melanope Pallas.

First specimens obtained September 10; rather abundant in rice-land; known to the residents of Polillo as "pi-yug-yug."

Budytes leucostriatus Homeyer.

Rare and shy; first seen early in October.

Anthus rufulus Vieillot.

Fairly abundant in rice-land.

Anthus gustavi Swinhoe.

First specimen was collected September 29.

PLOCEIDÆ.

Munia jagori Martens.

Abundant; a nest with four eggs was found late in September.

Uroloncha everetti (Tweeddale).

Abundant.

ORIOIIDÆ.

Oriolus acrorhynchus Vigors.

Abundant.

DICRURIDÆ.

Dicrurus balicassius (Linnæus).

The only specimen of *Dicrurus* collected, a female, appears to be of this species.

STURNIDÆ.

Lamprocorax panayensis (Scopoli).

Flocks of glossy starlings were noted several times, but none was collected.

Sarcops calvus (Linnæus).

The only specimen of bald starling from Polillo is intermediate between *S. calvus* and *S. melanonotus*.

CORVIDÆ.

Corone philippina (Bonaparte).

Abundant.

DESCRIPTIONS OF FOUR NEW SPECIES OF FISHES FROM
BANTAYAN ISLAND, PHILIPPINE ARCHIPELAGO.

By ALVIN SEALE.

(From the Section of Fisheries, Biological Laboratory, Bureau of Science, Manila,
P. I.)

Chaetodon carens Seale, sp. nov.

Head 3.10; depth 1.75; eye 2.80 in head; snout 3.25; interorbital 3; dorsal XIII, 21; anal III, 17; scales 7-38-20, the scales are larger on middle of sides; maxillary 4.50 in head, its distal end under nostril. Body slightly more elongate than is usual in this genus, strongly compressed, length of caudal peduncle 1.10 in its depth. Head of moderate size, characterized by the large eye, and short pointed snout; profile from tip of snout to origin of dorsal forms an angle of about 45° , the line from tip of snout to nuchal region is straight, slightly concave on the shoulder; the depth of the fish at origin of dorsal 1.75 in length to end of vertebra; origin of soft dorsal and origin of anal about on line. Mouth small; teeth brush-like in several rows, slightly projecting; gill openings wide, being carried forward to below eye; nostrils small, close together, in front of eye; gill rakers few, short and weak; dorsal spines rather long and saber-like, the third, fourth, and fifth the longest, the fourth 1.30 in head; dorsal and anal rounded; the origin of anal midway between middle of opercle and end of caudal vertebra; the second anal spine is the strongest and equal in length to the third spine, its length 1.50 in head; origin of ventrals midway between origin of anal and middle of cheeks, its tip extending slightly past anal pore; pectorals 1.10 in head.

Color in alcohol sepia-brown; no ocular band; nuchal region and top of head slightly darker, being a clove-brown; a wide black band on middle of spinous dorsal extends back and occupies almost the entire anal, except a narrow white tip and a small portion at the base of the anal spines; caudal yellow with a slight dusky wash on its posterior third; ventral brown with some indistinct yellowish blotches; pectorals yellowish white.

Type, No. 6173 in collection of Bureau of Science, from Bantayan Island, P. I. Length, 108 millimeters.

Chaetodon adiergastos Seale, sp. nov.

Head 3; depth at middle of dorsal 1.30; eye 3 in head; snout 3; interorbital 3; dorsal XII, 26; anal III, 21; scales 4-31-14; maxillary 4, its tip below nostril. Body short, deep, and strongly compressed; scales large on sides, small on head, soft dorsal, anal, and base of caudal. Head small, the profile steep, concave; snout small and pointed, its length about equal to width of eye; mouth small; teeth setiform, in several rows in each jaw, somewhat curved and projecting; nostrils small, close together and in front of eye; interorbital space slightly convex; gill openings large, being carried forward to below middle of eye; gill rakers few, short and weak; dorsal spines short and strong, the middle ones the longest, about 1.80 in head; soft dorsal rounded, similar to anal; origin of anal midway between anterior margin of eye and tip of caudal, the second anal spine strong and equal in length to the third which is slim; caudal truncate, its length 1.75 in head; ventrals midway between middle of cheek and origin of anal, the tip extending beyond the anal pore, the axil with an elongate scale; pectorals slightly less than head. Lateral line arched and high, ending at posterior angle of dorsal.

Color in alcohol is yellowish with numerous oblique brown lines extending down and forward over the entire side, each line marking the center of a row of scales, a jet-black ocular band of greater width than eye, the band not uniting above with its fellow, and its lower margin ending on the suboperculum. This band is very distinct and sharply defined, and is without marginal white borders, although the opercles and chin are almost white. On the shoulder midway between the first dorsal spine and the interorbital space is a small black saddle, not connected with the ocular band. Snout yellow, unmarked; soft dorsal and anal brown, with dark tips which have a rather narrow band across the posterior yellowish white area, basal third of fin brown; ventrals yellowish with some very indistinct darker blotches; pectorals yellowish.

Type, No. 5800 in collection of Bureau of Science, from Bantayan Island, P. I. Length, 116 millimeters. Also cotype No. 5791, length 111 millimeters.

This species is related to *C. flavirostris* Günther, but lacks the wide, dusky band from dorsal to anal which characterizes that species. Our species is more distinctly striped than *C. xanthurius* Bleeker. It differs also in having a wide ocular band and in being distinctly striped, the stripes running obliquely forward over the entire sides. It also has no "broad yellow band occupying the posterior part of the body," and neither the ocular band nor the saddle is bordered by a white line.

Amblygobius insignis Seale, sp. nov.

Head 3.60; depth 4.70; eye 4 in head; snout 4.10; maxillary 2.50; interorbital less than width of pupil; dorsal VI, 13; anal 13; scales 60-70 in lateral series. Head naked; no barbules; no serri. Teeth in two

or more rows with an outer row of enlarged curved canines in the anterior part of each jaw. Tongue rounded, not adnate to floor of mouth. Head rounded, angle of mouth under anterior third of eye.

Body oblong compressed; depth of caudal peduncle 2.30 in head; its length 1.75 in head. No hair-like filaments at upper part of pectorals. Origin of dorsal fin midway between tip of snout and base of sixth dorsal ray, the second, third and fourth dorsal spines slightly elongate, the second spine the longest, being almost equal to head; anal similar to soft dorsal, its longest ray 2.10 in head, its origin under the second ray of soft dorsal, its posterior rays not reaching to caudal; caudal rounded, 1.10 in head; ventrals fully united, their origin midway between tip of snout and origin of anal, their length 1.25 in head, their tips not reaching to anal opening; pectorals 1.10 in head.

The color markings of this species are very striking and characteristic, the posterior half of the body being covered with oblique bands of brown alternating with yellowish. These run downward and backward at an angle of about 70° ; the yellow bands are slightly less in width; below the spinous dorsal they are broken up. The coloring of the belly is lighter, with about six narrow white lines which extend entirely around the belly and nearly to the median line on sides. Two oblique narrow dusky lines extend forward across cheeks and around the throat, the anterior one just back of angle of jaw; some small black dots scattered over head and shoulders; about three very indistinct darker bands over nuchal region. Spinous dorsal yellowish with a dusky stripe near the margin and some dusky punctulations at base, soft dorsal with the alternating brown and yellowish bands of body extending into the fin and forming the markings; caudal grayish with indistinct yellowish vertical lines; some black dots on upper portion of fin; anal yellowish, the distal half black in which color are small scattered yellow dots; ventrals grayish, with a dusky wash on the posterior portion of the interior; pectorals yellowish, slightly darker at base.

Type, No. 5779 in collection of Bureau of Science, from Bantayan Island, P. I. Length, 58 millimeters. One specimen.

Amia griffini Seale, sp. nov.

Head 2.50 (including opercular flap); depth 2.25; eye 3.10 in head; snout 4.50; interorbital space 4; dorsal VII, 19; anal II, 8; scales 2-26-7; lateral line complete; two rows of scales on cheeks; posterior limb only of preopercle serrated. Mouth large, oblique, the maxillary ending under middle of eye; minute teeth in jaws, vomer and palatines; gill rakers rather long and strong, 15 on lower arch; gill openings large, being carried forward to below anterior third of eye.

Body oblong, compressed, the depth appearing greater than is usual in members of this genus; depth of caudal peduncle 1.25 in its length. Head deep and pointed, the profile almost straight; fins long, the soft

dorsal with the three anterior rays elongate, greater than length of head; first dorsal spine very minute, the second 1.30 in eye, the third and fourth the longest, 1.85 in head; origin of anal midway between base of caudal and posterior margin of eye, its second spine equal to width of orbit, its longest ray 1.75 in head; origin of ventrals on a line with origin of first dorsal, its rays reaching anal spines, its length 1.30 in head; pectorals 1.50 in head.

General color in alcohol mars-brown; yellow on belly; margins of the scales on sides above belly are shaded with minute brown dots. There is a very indistinct indication of five or six narrow dark stripes on the middle of the rows of scales anteriorly, scarcely to be distinguished in the cotypes; no marking on head; a brownish blotch on base of pectorals; a small black dot on base of caudal just above the lateral line, one of the cotypes is without dot. Dorsal fin grayish, the spinous dorsal slightly darker on margin; caudal yellowish, the margin grayish; anal yellowish at base shading into grayish on outer half; ventrals yellowish, their margins grayish; pectorals yellowish.

Type, No. 5701 in collection Bureau of Science, from Bantayan Island, P. I. Length, 125 millimeters. Cotypes, Nos. 5696 and 5698, from same locality. Length, 124 and 135 millimeters.

Named in honor of Dr. L. E. Griffin, the collector.

ILLUSTRATIONS.

PLATE I.

- FIG. 1. *Chatodon carens* Seale.
2. *Chatodon adiergastos* Seale.

PLATE II.

- FIG. 1. *Amblygobius insignis* Seale.
2. *Amia griffini* Seale.

96836—3



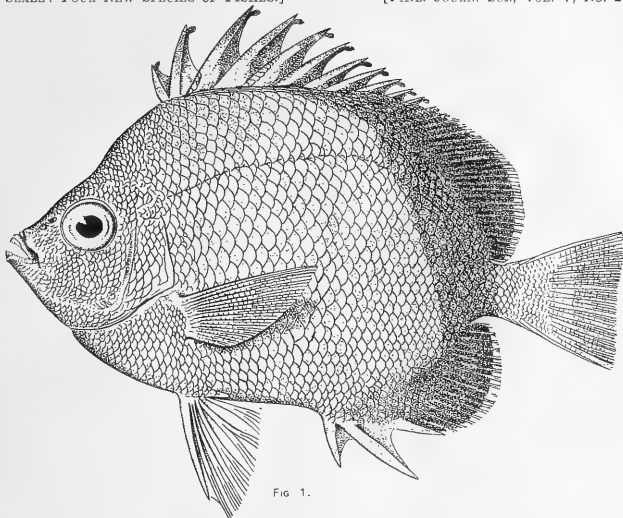

FIG. 1.

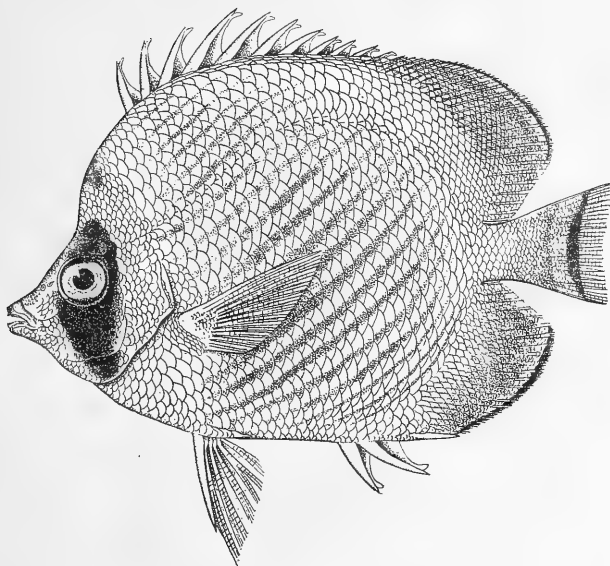

FIG. 2.

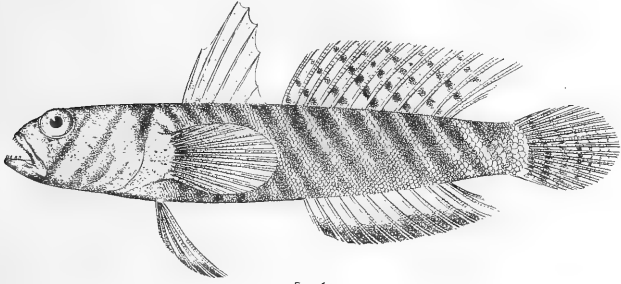

FIG. 1.

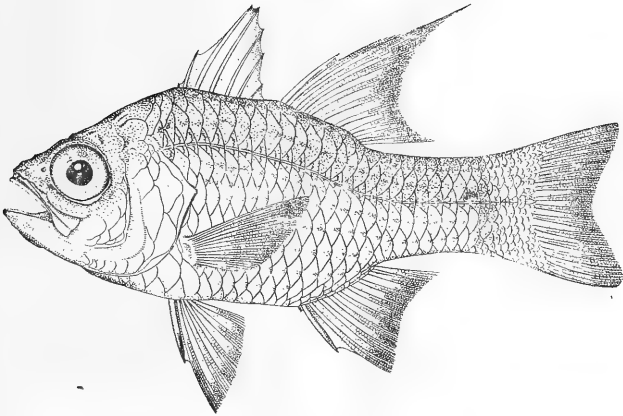

FIG. 2.

PLATE II.

✓ FOURMIS DES PHILIPPINES.

Par A. FOREL.

(Yvorne, Switzerland.)

Les fourmis énumérées ci-dessous et décrites font partie d'une collection reçue de M. Charles S. Banks, Entomologiste du Gouvernement au Bureau of Science à Manille, avec l'addition d'une espèce de l'île Sumatra récoltée par feu le Dr. Moesch.

1. *Odontomachus banksi* sp. nov.

♀ Long. 13 à 14 mill. Mandibules lisses, longues de presque 2 mill., ayant à l'extrémité 3 dents pointues, dont l'intermédiaire ou préapicale est la plus courte. Leur bord interne a de 3 à 4 fortes dents vers l'extrémité et de 6 à 8 petites dents vers la base. Tête longue de 3.5 mill., et large de 2.5 à la hauteur des yeux et de 2.0 à l'occiput. Bord antérieur de l'épistome presque droit. Yeux ovales, allongés dans le sens oblique. Sillon occipital profond. Bord postérieur de la tête non relevé en collerette; tête fortement échancrée derrière. Le scape dépasse le bord occipital de 2 fois son épaisseur. Second article du funicle $1\frac{1}{2}$ fois plus long que le premier. Mésonotum fortement et largement échancré, comme chez les *O. rivosus* et *papuanus* Em. Face déclive de l'épinotum très courte et abrupte. Nœud conique, n'ayant qu'un seul pan antérieur de la base au sommet de l'épine. Celle-ci longue et pointue, un peu courbée en arrière. Le pan postérieur présente sur le profil une convexité médiane en feston à chacun de ses bords. Une large dent en dessous, devant.

Lisse et luisant. Front strié en long de stries divergentes qui atteignent la portion postérieure des profondes fossettes antennaires. Les fossettes latérales d'Emery n'ont qu'une fine punctuation espacée. Thorax assez mat, transversalement strié; les stries de l'épinotum plus grossières, celles du pronotum fines et serrés, parfois longitudinales au milieu. Pilosité dressée, nulle sauf deux ou trois poils jaunes sur la tête et l'abdomen. Une pubescence jaunâtre, oblique soulevée et assez abondante, mais espacée, se trouve partout sur le corps et sur les membres.

Tête d'un roux jaunâtre. Thorax et écaille d'un brun noirâtre; abdomen d'un noir brunâtre. Mandibules, antennes, tarsi et articulations des pattes roux. Hanches, cuisses et tibia d'un jaune testacé clair.

Très voisin du *papuanus* Em., dont il diffère surtout par sa tête plus grande et plus large et par sa couleur.

Luzon, Province of La Laguna, Mount Banajao, P. I. (*Charles S. Banks* collector).

Type No. 7181 dans la collection entomologique du Bureau of Science, Manila. P. I.

2. ODONTOMACHUS INFANDUS Sm. ♀

Correspond assez bien à la description de Smith et montre une tendance du nœud du pédicule à prendre devant une forme ressemblant à celle de l'*imperator* Emery. Les stries de l'occiput sont superficielles et la tête derrière légèrement plus étroite que chez le *papuanus* dont il est bien voisin. Je ne connais pas le vrai *savissimus*, qui, m'assure M. Emery, diffère du *papuanus* par sa tête plus longue et plus étroite derrière.

NEGROS OCCIDENTAL, Pinalayan, Bago, P. I. (6908 *Banks*).

3. ODONTOPONERA TRANSVERSA Sm. ♀

NEGROS OCCIDENTAL, Nakalang, Bago, P. I. (35 *Banks*); MINDANAO, Camp Keithley, P. I. (7319 *Mrs. M. S. Clemens*).

4. DIACAMMA RUGOSUM LeGuill. subsp. GEOMETRICUM Sm. ♀

MINDANAO, Province of Davao, Davao, P. I. (2219 *E. B. Copeland*).

4. DIACAMMA RUGOSUM LeGuill. subsp. GEOMETRICUM Sm. var. VIRIDIPURPUREA Emery.

Luzon, Province of Rizal, Montalban, P. I. (5321 *Banks*).

6. *Platythyrea inermis* sp. nov.

♀ Long. 5.2 mill. Mandibules subopaques, densément ponctuées et pubescentes, longues, à bord terminal très distinctement denticulé et bien plus long que le bord interne. Epistome et front formant une forte convexité antéro-postérieure, sans sutures. Bord antérieur de l'épistome en arc convexe. Yeux assez plats, plutôt grands, situés en avant du milieu des côtés. Tête rectangulaire, médiocrement élargie derrière, à côtés médiocrement convexes et à bord postérieur faiblement échancré. Le scape atteint à peu près le bord postérieur de la tête. Les articles 6 à 10 du funicule sont un peu plus épais que longs. Suture promésotale profonde; suture mésoépilotale nulle. Dos du thorax à peine convexe. Face déclive de l'épilotum haute, abrupte, concave, régulièrement bordée en ovale de côté et en haut, sans trace de dent, ni de tubercule, ni d'angle. Nœud du pédicule aussi haut que le 1^{er} segment de l'abdomen, plus haut que long, mais un peu plus long qu'épais, verticalement tronqué devant et derrière, mais à face antérieure convexe, tandis que sa face postérieure est concave et bordée comme la face déclive de l'épilotum, mais obtusément. Abdomen médiocrement étranglé entre ses deux premiers segments; le 2^{me} un peu plus long que le 1^{er}. Hanches postérieures sans trace d'épine.

Densément et finement ponctuée, subopaque ou à peu près mate. La ponctuation superposée (espacée) n'est pas grossière; elle est distincte, régulièrement espacée et luisante sur la tête, moins distincte sur le pédicule et à la base de l'abdomen, très effacée ou nulle ailleurs. Pubescence pruinuse extrêmement fine assez abondante partout, sans être très dense.

Noire. Pattes, funicules, mandibules et arêtes frontales d'un brun rougeâtre, devant de l'épistome et scapes bruns.

LUZON, Province of Rizal, Montalban Gorge, P. I. (*Charles S. Banks*, collector).

Type No. 5431 dans la collection entomologique du Bureau of Science, Manila, P. I.

7. *SOLENOPSIS GEMINATA* Forel, subsp. *RUFa* Jerdon ♀ ♂.

NEGROS OCCIDENTAL, Maaao, P. I. (878 *Banks*); LUZON, Manila, P. I. (3133 *Banks* and 8931 *P. L. Jones*).

8. *PHEIDOLOGETON DIVERSUS* Jerdon ♂

LUZON, Manila, P. I. (4200 *Banks*).

9. *Monomorium floricola* Jerdon, var. *philippinensis* var. nov.

♀ Identique à la forme typique. Tout au plus l'échancrure thoracique est elle un peu plus faible et les nœuds sont ils un peu plus comprimés d'avant en arrière, moins épaissement arrondis au sommet.

♀ Long. 3.2 à 3.3 mill. Plus grande, surtout plus robuste que l'espèce typique et d'un brun unicolore, avec les pattes et les antennes (sauf la massue et les cuisses brunes) jaunâtres. Epinotum plus court. Second nœud bien plus comprimé, plus court et plus large, moins arrondi.

La femelle se distingue de prime abord du *floricola*, tandis que l'ouvrière est bien difficile à différencier.

LUZON, Manila, P. I. (*Charles S. Banks*, collector).

Type No. 5862 dans la collection entomologique du Bureau of Science, Manila, P. I.

10. *MONOMORIUM (MARTIA) ORIENTALE* Mayr ♂

NEGROS OCCIDENTAL, Nakalang, Maaao, P. I. (47 *Banks*).

11. *Monomorium (Martia) banksi* sp. nov.

Long. 1.4 mill. Légèrement plus grand que l'*atomus* Forel, mais plus petit que l'*orientale* Mayr. Mandibules lisses, plus larges que chez l'*atomus*. Epistome armé de deux carènes plus aiguës, divergeant beaucoup moins en avant. Tête rectangulaire, un peu plus longue que large, distinctement échancrée derrière, à côtés pas ou à peine convexes. Yeux avec une dizaine de facettes, comme chez l'*atomus*. Antennes de 11 articles, comme chez l'*atomus*. Nœuds presque anguleux au sommet, moins arrondis que chez l'*atomus* et beaucoup moins que chez l'*orientale*.

Entièrement lisse et luisant, avec quelques poils dressés épars comme chez l'*atomus* (moins que chez l'*orientale*).

Entièrement d'un jaune sale ou brunâtre un peu moins foncé que chez l'*orientale*, mais bien moins vif que chez l'*atomus*. Pattes et antennes d'un jaune plus pâle. Les ondes transversales un peu plus brunes, à peine perceptibles au milieu de segments abdominaux. Du reste comme l'*atomus*.

Intermédiaire entre *atomus* et *orientale*, mais avec les carènes de l'épistome plus vives et les nœuds plus anguleux que chez ces deux espèces.

♀ Long. 3 mill. D'un brun jaunâtre clair, avec l'extrémité des segments abdominaux, les pattes et les antennes d'un brun jaune pâle. Premier nœud, vu de profil, conique, le 2^{me} bien plus large que long (tous deux arrondis, le 2^{me} aussi long que large chez l'*atomus* var. *integrius*). L'épinotum beaucoup plus court que chez l'*atomus*. Tête bien plus étroite et plus allongée que chez l'*orientale*.

Moins grêle que l'*atomus*, mais beaucoup plus petite et plus grêle que l'*orientale*.

NEGROS OCCIDENTAL, Nakalang, Maa, P. I. (Charles S. Banks collector).

Type ♀ ♂ No. 53 dans la collection entomologique du Bureau of Science, Manila, P. I.

12. CREMATOGASTER DEFORMIS Sm. ♂

MINDANAO, Province of Davao, Davao, P. I. (2214 E. B. Copeland).

13. CREMATOGASTER ROGENHOFERI Mayr ♂ ♀ ♂

MINDANAO, Province of Davao, Davao, P. I. (2220 E. B. Copeland).

14. CREMATOGASTER SIMONI Emery ♂

LUZON, Manila, P. I. (3041 Banks).

15. *Cremastogaster subnuda* Mayr, subsp. *politula* Forel, var. *tagala* var. nov.

♀ Long. 2.7 mill. Très voisine de la var. *ruginota* Forel de l'Inde, et avec la même sculpture sur le thorax, mais les épines épinotales sont bien plus longues, le premier nœud est un peu plus large et plus court, et la couleur plus foncée (tête et abdomen d'un brun foncé; thorax et pédicule d'un rouge brun).

♀ Long. 5.6 mill. D'un brun roussâtre. Abdomen d'un brun plus foncé. Epinotum presque absolument inerme ou avec deux tubercules très obtus. Plus petite espèce. Ailes hyalines. (La ♀ de la var. *ruginota* n'est pas connue; celle de la subsp. *politula* typique est noire, faiblement subdentée à l'épinotum et longue de 7 mill.).

♂ Long. 2.3 mill. D'un jaune brunâtre sale; tête d'un brun noir. Plus petit et plus grêle que celui du *politula* typique, et avec l'épinotum subopaque, finement sculpté (celui du *politula* est noir et a l'épinotum luisant et les ailes plus longues).

Il est fort possible que la var. *ruginota* doive être élevée au rang de sous-espèce et séparée ainsi de *politula*, auquel cas la var. *tagala* devra se

rattacher non au *politula* typique, dont il diffère beaucoup, mais au *ruginota*.

LUZON, Manila, P. I. (*Charles S. Banks* collector).

Type ♂ ♀ § No. 2792 dans la collection entomologique du Bureau de Science, Manila, P. I.

16. *Cremastogaster modiglianii* Emery, var. *clemensæ* var. nov.

§ Long. 2.7 à 3.2 mill. Diffère de la forme typique par sa sculpture plus faible (derrière de la tête luisant) et de la var. *annamita* Em., en outre par l'absence de la petite carène médiane du pronotum qu'on voit chez cette dernière (dont la couleur est en outre plus foncée et la sculpture plus forte que chez la forme typique).

MINDANAO, Camp Keithley, P. I. (*Mrs. M. S. Clemens* collector).

Type § No. 5537 dans la collection entomologique du Bureau de Science, Manila, P. I.

17. *Vollenhovia oblonga* Sm., subsp. *dispar* subsp. nov.

§ Long. 3.2 mill. Mandibules plus courtes et plus larges que chez le type de l'espèce, armées de 6 dents, et de forme nettement triangulaire, formant un angle net entre le bord terminale et le bord interne. Les carènes de l'épistome sont plus élevées, moins divergentes devant et plus prolongées en arrière que chez la subsp. *levithorax* Em.; pronotum court, déprimé et plus épaulé devant; premier nœud du pédicule plus court, plus large que long, avec un pan antérieur absolument vertical (oblique chez *levithorax*). Pattes entièrement d'un rouge jaunâtre. Du reste comme la subsp. *levithorax*.

♀ Long. 8 mill. Mandibules armées de 7 dents, ponctuées. Tête en trapèze, rétrécie devant, un peu plus large derrière qu'elle n'est longue. Thorax plus large que la tête. Tête striée-ridée en long; les rides divergent en arrière et leurs intervalles sont rugueux, subopaques. Thorax avec de rides longitudinales effacées et des séries de points allongés entre deux; une bande médiane, longitudinale lisse. Epinotum et une partie des nœuds irrégulièrement ridées. Abdomen lisse, à points épars, piligères très fins.

Noire. Bord antérieur de la tête, mandibules, antennes et pattes rougeâtres. Ailes brunes, avec une cellule cubitale allongée et une cellule discoïdale. Du reste comme l'ouvrière.

♂ Long. 3.8 mill. Mandibules courtes, étroites, jaunes, obtusément unidentées. Tête arrondie derrière, au moins aussi large que longue. Epistome très convexe et proéminent. Les yeux occupent la moitié antérieure de la tête. Antennes de 13 articles. Scape long comme les 3 premiers articles du funicule pris ensemble. Ceux-ci sont courts, presque aussi épais que longs; les quatre ou cinq derniers sont longs, formant une massue fort indistincte. Thorax plus large que la tête. Epinotum et tête assez mats densément et finement sculptés. Le reste

plus ou moins lisse et ponctué. Sauf sur le dos de l'abdomen, la pilosité dressée brun roussâtre est plus abondante que chez les ♂ et ♀.

D'un noir un peu brunnâtre. Pattes brunes. Articulations, mandibules et antennes jaunâtres. Ailes d'un brun plus clair que chez la ♀. Cellule discoïdale distincte.

La ♀ est beaucoup plus grande, presque double de celle de l'espèce typique d'après Smith et Emery. Les caractères génériques du ♂ correspondent assez bien à ceux indiqués par Mayr (var. *samoensis*).

Luzon, Province of La Laguna, Mount Banajao, P. I. (*Charles S. Banks* collector).

Type ♂ ♀ ♂ No. 7189 dans la collection entomologique du Bureau of Science, Manila, P. I.

18. *Vollenhovia banksi* sp. nov.

♂ Long. 1.8 à 2 mill. Mandibules lisses, luisantes, assez triangulaires, avec trois dents peu distinctes sur la partie antérieure de leur bord terminal que est à peu près tranchant derrière elles. Epistome court, avec une faible impression médiane. Tête rectangulaire d'un bon sixième plus longue que large, à peine rétrécie derrière. Le scape atteint ou dépasse un peu le quart postérieur de la tête. Chassue très distinctement de 3 articles, dont les deux derniers fort renflés. Bord postérieur de la tête faiblement échanuré. Yeux médiocres légèrement en arrière du tiers antérieur de la tête. Arêtes frontales très courtes. Thorax allongé, à dos subdéprimé, presque rectiligne sur son profil d'avant en arrière (à peine convexe). Sutures très peu marquées, la promésotale presque obsolète. Pas trace d'échancre. La face basale de l'épinotum bien plus longue que large et plus longue que la face décline. Premier nœud plus long que large. Second nœud légèrement plus large que long. Cuisses médiocrement renflées, bien moins que chez la *subtilis* Emery.

Tête et pronotum à peu près mats, finement et densément ridés en long; épistome luisant avec peu de rides. Une raie luisante et lisse à la place du sillon frontal; milieu du pronotum, devant, un peu luisant. Mésonotum à la fois ridé et réticulé. Epinotum, côtés des nœuds et côtés du mésonotum mats et densément réticulés—ponctués. Abdomen, sommet des nœuds et pattes lisses. Tout le corps, les pattes et les scapes recouverts d'une pubescence jaunâtre oblique (soulevée), assez abondante, quoique espacée. Pilosité dressée jaunâtre, fine pointue, éparsée sur le corps, nulle sur les tibias et les scapes.

Corps et cuisses bruns; pattes, antennes et mandibules d'un jaune sale.

NEGROS OCCIDENTAL, Nakalang, Maa, P. I. (*Charles S. Banks* collector).

Type ♂ No. 67 dans la collection entomologique du Bureau of Science, Manila, P. I.

19. *DOLICHODERUS BITUBERCULATUS* Mayr ♂
 LUZON, Manila, P. I. (4490 W. *Schultze*).
20. *DOLICHODERUS PATENS* Mayr subsp. *PUBIVENTRIS* Emery ♀ ♂
 PALAWAN, Iwahig, P. I. (8897 F. W. *Foxworthy*).
 Cette forme constitue, plus ou moins, un intermédiaire entre *patens* Mayr, dont elle a la sculpture, et *semirugosus* Mayr, dont elle a la couleur; mais l'abdomen est plus pubescent que chez tous les deux.
21. *PRENOLEPIS LONGICORNIS* Latr. ♀ ♂
 Cosmopolite. LUZON, Manila, P. I. (2890 *Banks*).
22. *PLAGIOLEPIS LONGIPES* Jerdon ♀.
 NEGROS OCCIDENTAL, Pinalayan, Bago, P. I. (6907 *Banks*).
23. *CAMPONOTUS (COLOBOPSIS) VITREUS* Smith ♀. ♂.
 LUZON, Province of Zambales, Olongapo, P. I. (12860 *Banks*).
24. *CAMPONOTUS (COLOBOPSIS) PUBESCENS* Mayr ♂
 LUZON, Province of Lepanto-Bontoc, Cervantes, P. I. (8790 *Banks*).
25. *CAMPONOTUS MACULATUS* Fabr. subsp. *PALLIDUS* Sm. ♂
 LUZON, Manila, P. I. (2579 *Banks*).
26. *CAMPONOTUS MACULATUS* Fabr. subsp. *SUBNUDUS* Em. ♀ ♂
 LUZON, Manila P. I. (2506 W. *Schultze*).
27. *CAMPONOTUS QUADRISECTUS* Sm. ♂
 LUZON, Province of La Laguna, Santa Maria, P. I. (8606 H. M. *Curran*).
28. *Camponotus horrens* sp. nov.
 ♂ Long. 5.5 mill. Mandibules lisses, luisantes, étroites, armées de 5 dents; l'angle entre le bord interne et le bord terminal très obtus. Epistome très convexe, subcaréné au milieu, à bord antérieur biéchancré, sublobé entre les échancrures, faiblement imprimé au milieu dudit bord antérieur. Aire frontale bien plus large que longue, mal délimitée en arrière. Sillon frontal remplacé par une carène longitudinale assez courte. Arêtes frontales plutôt courtes, très divergentes. Tête large, fort convexe, trapézoïdiforme, à côtés convexes, fortement rétrécie devant, au moins aussi large derrière que longue, à bord postérieur presque droit. Yeux convexes, situés au quart postérieur de la tête. Le scape dépasse le bord occipital des $\frac{2}{5}$ à la moitié de sa longueur. Thorax conformé comme chez le *C. sexguttatus* Fabr., mais encore plus profondément échancré entre le mésonotum et l'épinotum. Ce dernier forme une bosse allongée, dont l'extrémité antérieure, arrondie en haut, tombe en haute marche d'escalier sur la suture méso-épinotale. Vue de dessus cette bosse est subdéprimée, plus longue que large, mais à peine plus étroite que le mésonotum; face déclive mal délimitée, plus courte que la face basale.

Quoique un peu plus haute et à bord supérieur plus arrondi (plus obtus), l'écaïlle a la forme de celle du *C. quadrilaterus* Mayr; tres épaisse en bas, avec un pan antérieur vertical très court, puis avec une surface oblique montant au bord supérieur, et enfin avec un pan postérieur haut et vertical. Abdomen court; pattes longues, sans piquants. Tibias cylindriques.

Luisant, superficiellement et peu distinctement réticulé; épinothum subopaque, transversalement chagriné. Des points piligères espacés fort distincts et formant de petites élévations, surtout sur la tête, le thorax et les membres. Tout le corps, les pattes et les scapes hérissés de longs poils grossiers et pointus, d'un brun foncé, en partie presque noirâtres vers leur base, plus clairs à l'extrémité, très abondants sur l'épinothum, les tibias et les scapes. En outre une pubescence fauve dispersée partout ailleurs, mais assez abondante sur l'abdomen où elle forme un léger duvet.

Entièrement d'un brun roussâtre, rappelant beaucoup celui des *Myrmicaria eumenoides* Gerst et *brunnea* Saunders. Abdomen d'un brun foncé.

L'analyse de couleur, de forme, de pilosité, d'éclat et de taille avec la *Myrmicaria brunnea* qui habite les mêmes parages est telle que je soupçonne fortement cette espèce d'être mimétique et d'avoir quelque relation correspondante avec la *Myrmicaria brunnea*.

LUZON, Province of Rizal, Montalban Gorge, P. I. (*Charles S. Banks* collector); NEGROS OCCIDENTAL, Mailum, Bago, P. I. (6906 *Banks*).

Type ♀ No. 5433 dans la collection entomologique du Bureau of Science, Manila, P. I.

29. *ECHINOPLA STRIATA* Smith ♀.

NEGROS OCCIDENTAL, Pinalayan, Bago, P. I. (6909 *Banks*).

30. *POLYRHACHIS CYANIVENTRIS* Smith ♀ ♀.

LUZON, Province of Rizal, Montalban Gorge, P. I. (5427 *Banks*); MINDORO, Mount Halcon, P. I. (6232 *E. D. Merrill*).

♀ Long. 11.2 mill. Du reste toute semblable à l'ouvrière. Ailes brunes. Les scapes de cette espèce, très large et robuste, sont fortement renflés à l'extrémité chez la femelle et l'ouvrière, ce que Smith et Mayr n'ont pas mentionné.

31. *POLYRHACHIS ARMATA* LeGuillon ♀.

NORTH CAMIGUIN ISLAND, P. I. (7791 *R. C. McGregor*).

32. *POLYRHACHIS SCULPTURATA* Smith ♀ ♀.

NEGROS OCCIDENTAL, Mailum, P. I. (6070 *Banks*).

33. *POLYRHACHIS BIHAMATA* Drury ♀.

NEGROS OCCIDENTAL, Mount Canlaon, Tabidiao, P. I. (5719 *Banks*).

34. *POLYRHACHIS SEXSPINOSA* Latr. var. *ESURIENS* Em., ♀.

NEGROS OCCIDENTAL, Nakalang, Maa, P. I. (2170 *Banks*).

35. *Polyrhachis bicolor* Smith. var. *concolor* var. nov.

♀ Diffère du type de l'espèce par sa couleur entièrement noire, avec les antennes, les mandibules, les pattes et tout au plus la base de l'abdomen d'un brun un peu roussâtre. Tout le corps, y compris l'abdomen, est recouvert d'une pelisse argentée aussi brillante que celle de *P. acantha* var. *argentea*. Du reste la forme et les épines grêles sont identiques à celles du type de la espèce. La ♀ et le ♂ sont comme l'ouvrière, avec les ailes enfumées de brunâtre et les nervures brunes. Chez le ♂ la pubescence est diluée.

Luzon, Manila, P. I. (*Charles S. Banks* collector).

Type ♂ ♀ ♀ No. 4224 dans la collection entomologique du Bureau of Science, Manila, P. I.

36. *Polyrhachis textor* Smith var. *æqualis* var. nov.

♀ Long 4.6 à 5.2 mill. Correspond bien exactement à la description de Smith, mais les trois épines de l'écaille sont de longueur égale.

♀ Long. 6.5 mill. Pronotum avec deux angles obtus; épinothum avec deux larges dents, fortes et obtuses. Les 3 épines de l'écaille de longueur égale. Ailes jaunâtres, avec les nervures et la tache marginale jaunes.

Luzon, Province of Zambales, Olongapo, P. I. (*Charles S. Banks* collector); NEGROS OCCIDENTAL, Maaao, P. I. (866 *Banks*).

Type ♀ ♀ No. 12869 dans la collection entomologique du Bureau of Science, Manila, P. I.

***Camponotus mœschii* sp. nov.**

♀ Long. 4.5 mill. Mandibules assez luisantes, finement chagrinées et abondamment ponctuées, assez étroites, armées de 5 dents au bord terminal et d'un denticule au bord interne. Epistome caréné avec un lobe arrondi devant. Tête peu large en trapeze peu marqué, plus longue que large, médiocrement élargie derrière, à bord postérieur convexe. Yeux grands, au tiers postérieur. Le scape dépasse le bord postérieur d'un bon tiers. Arêtes frontales divergentes; aire frontale transversale; sillon frontal peu distinct. Suture promésonotale profonde, constituant une échancrure distincte, quoique faible, du dos du thorax. Echancrure mésoépinothale moins profonde que chez le *C. horrens* (moins abrupte surtout), environ comme chez le *sexguttatus* (♀ major), mais l'épinothum est un peu plus court, plus convexe d'avant en arrière, et plus comprimé, beaucoup plus étroit que chez l'*horrens*, nullement déprimé dessus (sans face supérieure distincte). Face déclive légèrement concave, plus courte que le dos ou face basale. Ecaille mince, comprimée, à bord supérieur subrectiligne. Abdomen court; pattes plutôt grêles; tibias cylindriques, sans piquants.

Luisant, superficiellement et peu distinctement chagriné (épinothum inclusivement), avec les mêmes points piligères élevés que chez l'*horrens*. Pilosité dressée jaunâtre, pointue, assez abondante et longue sur l'ab-

domen et le derrière de la tête, plus courte sur le thorax et le devant de la tête. Les tibias et les scapes n'ont qu'une pilosité oblique (demi-conchée) et courte. Pubescence adjacente presque nulle.

Entièrement d'un roux jaunâtre, en partie un peu brunâtre; funicules et pattes d'un jaune roussâtre, ainsi que l'épistome et les joues.

SUMATRA, récolté par feu le Dr. Moesch. J'avais pris cette espèce autrefois pour le *C. nutans* Mayr, mais c'est autre chose. Elle est parente du *C. horrens*, mais néanmoins bien différente. Les ♀ sont toutes de même grandeur (♀ minor ou media?).

Type dans ma collection.

V A NEW ACCESSORY FOR DISSECTION WORK.

By CHARLES S. BANKS.

(From the Entomological Section, Biological Laboratory, Bureau of Science,
Manila, P. I.)

In the course of my studies in insect anatomy, I have had occasion to use a small, easily made piece of apparatus with such excellent results that I believe it to be worth noting, especially as I have never seen mention of a similar accessory.

This apparatus is especially adapted for such delicate work as that of differentiating the parts of the alimentary canal and the reproductive organs in small, adult insects such as *Bombyx mori* Linn., and it also serves admirably for all kinds of larvæ and for larger adult insects: Arachnida, Lumbricidæ, Cestodea, Nematodea and Myriapoda, as well as for small vertebrates, the dissection of which could be performed in normal salt solution, or other similar liquid.

The apparatus is really nothing more than the classical pin of our school days, fashioned on slightly different lines from that well-known weapon of offense and defense, and is made from brass or nickel insect pins No. 3 or No. 5. I have used two styles of this pin, one in which the base forms two sides of an equilateral triangle, the other in which the triangular base is complete. (See Plate I, *a* and *b*.) A bend is made 5 to 10 millimeters from the point so as to form an angle of 60° ; the other bends are made so that when completed the point comes over the center of the triangular base. The only advantage in using style *a* is that the base is larger and somewhat greater stability is thereby secured.

The subject to be dissected is cut open, laid in normal salt solution in the dissecting pan with paraffine in the bottom, and the flaps of integument are stretched open and fastened with ordinary pins.

With a number of the bent pins at hand, lying loose upon the paraffine, one may begin tearing away any part desired, the trachea probably first demanding attention. As each part is freed, a bent pin is seized by the forceps and its point hooked under a loop of the tissue. The bent pin is then gently pulled away as far as possible and set down upon its base on the paraffine. As other parts are dissected, successive bent pins are

used. Where overlapping parts occur it is an easy matter to release them, pick them up from beneath and drop the bent pin where most convenient for holding the tissue apart. While its own weight and the adhesion of the base of the bent pin to the paraffine are amply sufficient to hold the tissues apart, yet it can so easily be moved that there is practically no danger of tearing important organs by an inadvertent pull with the forceps, and in this lies the chief value of this method.

I have found that organs as delicate and as intricately enmeshed in tracheæ as are the ovaries or the abdominal nerve fibers and ganglia of *Bombyx mori* Linn., and *Attacus ricini* Boisd., may be admirably dissected by the use of the bent pin, whereas an attempt to hold them with ordinary pins stuck into the paraffine would result in disaster to the specimen. Another value of this apparatus is that it may be picked up with the engaged tissue and moved here and there at will and with greater dispatch than if ordinary pins were used. There is also no danger of pinning the part into the paraffine.

Perhaps a no less useful feature of the bent pin is that it may be used most successfully in glass vessels, e. g., Petri dishes, where obviously no other method of holding tissues could be devised.

This apparatus will be found particularly useful in the class room or in the anatomical laboratory where a lack of skill on the part of students would be compensated for by a diminished liability to spoil specimens upon which hours of careful dissection had been spent. In making the apparatus it is better to use the pointed end of the pin for a hook, as the tissue can be more readily slipped off.

Plate I shows several of these bent pins in use in the dissection of a silkworm in a Petri dish.

ILLUSTRATION.

PLATE I. *a* and *b*, showing different methods of using bent pins, in dissection work.

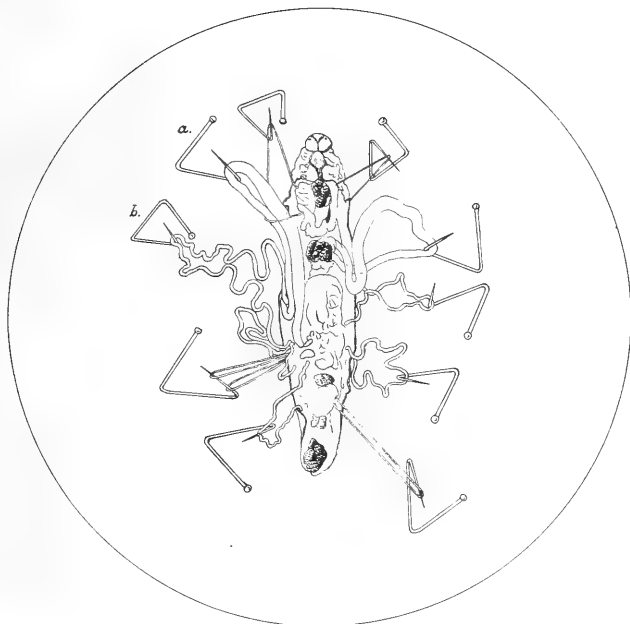

PLATE I.

✓ BIRDS FROM PAUAI AND MOUNT PULOG, SUBPROVINCE
OF BENGUET, LUZON.

By RICHARD C. MCGREGOR.

(From the Ornithological Section, Biological Laboratory, Bureau of Science,
Manila, P. I.)

INTRODUCTION.

Pauai, or Haight's, is some 56 kilometers from Baguio, near the main mountain trail between Baguio and Bontoc, in the subprovince of Benguet, Luzon, and has an approximate elevation of 2,250 meters. The trail is built through forests of island pine, *Pinus insularis* Endl., while the vegetation about Pauai is the mossy forest, characteristic of many mountain tops in the Philippine Islands.

The change in the flora from pine forest to mossy forest is very abrupt and the line of demarcation between the two is as distinct as can be imagined. The trunks and branches of the trees are covered with masses of ferns, orchids, lichens, and mosses producing a striking and characteristic appearance and many of the shrubs, grasses, and other small plants are of genera different from those inhabiting the pine woods.¹

During May and June, 1908, with my assistant, Andres Celestino, I made a collection of birds at Pauai. Of the twenty-two species collected or noted in the mossy forest, only two, *Pyrrhula leucogenys* Grant and *Rhinomyias insignis* Grant, appear to be confined to the mossy forest, as all of the others have been collected at lower altitudes. The poverty of the avian fauna of these high mountains is emphasized when it is remembered that seventy-two species were recorded from Irisan, near Baguio.

In July we spent three days collecting in the mossy forest on Mount Pulog, a peak some 10 kilometers east of Pauai and 2,800 meters in elevation. On our return from Mount Pulog we were detained for a few days at Lutab, a barrio of Cabayan, elevation about 1,000 meters. Very few birds were noted in the vicinity of Lutab. *Hirundo striolata* (Boie) was seen on July 5 and 6, an immature male of *Chaimarrornis*

¹ This *Journal Sec. C* (1910) 5, Nos. 4, 5, with a paper on the flora of Mount Pulog by Merrill and Merritt, will be found plates showing some of the botanic and physiographic features of this section of Benguet.

bicolor Grant was collected, and the following species were seen in some numbers: *Iole gularis* (Pucheran), *Cacomantis merulinus* (Scopoli), *Anthus rufulus* Vieillot, *Cisticola exilis* (Vigors and Horsfield), *Munia cabanisi* Sharpe, and *Pycnonotus goiavier* (Scopoli).

BIRDS OF PAUAL.

Prioniturus montanus Grant.

Abundant; many specimens.

Batrachostomus microrhynchus Grant.

One male, collected June 4, is in the gray phase of plumage. Wing, 140 millimeters; tail, 114; bill from nostril, 14; greatest width of bill, 30; internasal line, 16; tarsus, 17. The stomach contained beetles.

Collocalia species.

Swiftlets were frequently seen, but it was impossible to obtain specimens of them.

Yungipicus validirostris Blyth.

This little woodpecker was not uncommon.

Chrysocolaptes hæmatribon (Wagler).

One pair of this species was collected.

Thriponax javensis (Horsfield).

Seen but once.

Muscicapula westermanni Sharpe.

Westermann's flycatcher is represented in this collection by two adult males, and one male and one female in spotted plumage.

Muscicapula luzoniensis Grant.

One female was taken June 12.

Rhipidura cyaniceps (Cassin).

Fairly abundant and usually found in flocks with other species of small birds.

Rhinomyias insignis Grant.

Very rare; one male was collected June 15. Length, 170 millimeters. Iris light brown; bill black; legs and feet lead-blue.

Culicicapa ceylonensis (Swainson).

Two males collected.

Cryptolopha nigrorum Moseley.

This inconspicuous little bird was one of the most abundant species recorded.

Eumyias nigrimentalis (Grant).

The black-masked verlitter flycatcher was abundant. Many specimens, both immature and adult, were collected.

Zosterornis whiteheadi Grant.

Whitehead's tree babbler was very abundant and was often observed in company with other small birds.

Brachypteryx poliogyna Grant.

Very abundant, but shy and difficult to collect. A young female, May 24, may be described as follows: Above dark brown; feathers of the crown, nape, sides of neck, and breast with rusty-brown median lines; chin and throat rusty-brown; no blue anywhere in the plumage.

Planesticus thomassoni (Grant).

Very abundant. A young male, with tail just showing, has the plumage nearly all black; head, neck, and throat black; middle of lower breast and abdomen with shaft-lines of rusty-brown; feathers of abdomen, thighs, and under tail-coverts fringed with rusty brown.

Hörornis seebohmi (Grant).

The plumage of young birds differs somewhat from that of the adult. Above blackish-brown, head like the back; under parts dusky olive-brown; chin and middle of abdomen light ochreous-brown.

Cephalophoneus validirostris (Grant).

Three specimens collected; not common.

Hyloterpe albiventris Grant.

Fairly abundant; three males collected.

Pardaliparus elegans (Lesson).

This titmouse is one of the most conspicuous elements in the flocks of small birds seen in the mossy forest. A young male, collected May 24, has the upper plumage suffused with dark olive-green; below yellow, throat and chin yellow, but with a dark streak along each side of the throat.

Callisitta mesoleuca (Grant).

Very common in flocks of small birds.

Pyrrhula leucogenys Grant.

This bullfinch is one of the few birds the range of which is limited to the mossy forest. Two, three, or four individuals were usually observed together and feeding, nearly always, in the larger evergreens. Single birds could at times be attracted by imitating their plaintive whistle. Iris dark brown; legs and feet clay-color or pale flesh-color; nails gray; bill mostly black, more or less of the basal portion of the lower mandible yellowish white. The young is similar to the adult, but crown and nape brown, slightly darker than the back; the white cheek-patch small and ill-defined; chin brown like the throat.

BIRDS OF MOUNT PULOG.

Prioniturus montanus Grant.

Several individuals seen in the mossy forest.

Collocalia whiteheadi Grant.

A small flock of swiftlets was seen near the summit of the mountain. The single specimen collected is doubtfully identified with *C. whiteheadi*. Compared with skins from Irian, Benguet, this specimen is somewhat darker and more blackish on the head and back, while the wing is shorter. A smaller species of swiftlet was noted, possibly it was *C. isonota*.

Rhipidura cyaniceps (Cassin).**Cryptolopha nigrorum** Moseley.**Eumyias nigrimentalis** Grant.

These three species of flycatchers were more or less abundant in the mossy forest.

Iole gularis (Pucheran).

Several fruit thrushes were noted near the Igorot barrio of Ankiki, just below the mossy forest.

Zosterornis whiteheadi Grant.

Two specimens collected July 3.

Brachypteryx poliogyna Grant.

Several seen in the mossy forest.

Planesticus thomassoni (Seebohm).

One specimen collected July 4.

Horornis seebohmi (Grant).

A young spicemen was caught with an insect net, near the base of the mountain.

Zosterops whiteheadi Hartert ?

A female silvereye, killed near Ankiki, is doubtfully referred to *Z. whiteheadi*.

Pyrrhula leucogenys Grant.

A pair of bullfinches was collected near timber-line and others were seen.

VERZEICHNISS VON COLEOPTEREN AUS DEN PHILIPPINEN,
NEBST ZWEI NEUEN ARTEN AUS NIEDERLÄNDISCH-
OSTINDIEN.

Von J. WEISE.
(Berlin, Germany.)

Herr W. Schultze, Assistent-Entomolog am Bureau of Science in Manila, welcher seinen Urlaub in Europa verlebte, brachte eine Anzahl von Coleopteren zur Bestimmung mit, die in den Philippinen gefangen wurden. Von den Chrysomeliden und Coccinelliden gebe ich hier eine Aufzählung in der die im Cataloge von Baer nicht genannten Arten mit einem * versehen sind.

I. CHRYSOMELIDEN.

*1. *DONACIA WIEPKENI* Ws., Arch. f. Nat. (1898), 178.

LUZON, Province of Tarlac, Tarlac, P. I. (4688 *C. S. Banks*).

*2. *LEMA SEMPERI* Jac., Ann. Soc. Ent. Belg. (1893), 267; var.

Flügeldecken einfarbig metallisch grünlich-blau; Spitze der Schienen und Tarsen schwärzlich.

BATANES ISLANDS, Calayan, P. I. (944 *R. C. McGregor*).

*3. *CRIO CERIS SEMIPUNCTATA* Fabr., Syst. Eleut. (1801), 1, 472.

ROMBLON, P. I. (1985 *R. C. McGregor*).

*4. *Phytorus latus* sp. nov.

Subrotundus (♀) vel transversim rotundatus (♂), fulvescens, capite prothoraceque obscure aut saturate brunneo-rufis, hoc crebre punctato, juxta marginem anticum sublaevi, elytris prothorace duplo latioribus, punctulato-striatis, intersticiis convexiusculis, stria duodecima integra. — Long. 6 mm., lat. ♂ 7, ♀ 5.5 mm.

ROMBLON, P. I. (*R. C. McGregor* collector).

Type No. 1973, in der Entomologischen Sammlung des Bureau of Science, Manila, P. I.

Von den übrigen Arten durch den sehr breiten Körperbau, besonders aber durch den Verlauf des zwölften Punktstreifens ausgezeichnet. Derselbe bildet bei den typischen Arten nur einen Strich, der bald hinter der Schulter erlischt, in der vorliegenden Art ist er vollständig,

höchstens fehlt zuweilen eine Spur an der Basis; hinten verbindet er sich regelmässig mit dem dritten Streifen.

Gerundet, fast so breit (φ), oder breiter als lang (δ), hell und lebhaft bräunlich rotgelb, glänzend, Fühler mehr rostrot, Kopf und Thorax hell kastanienbraun, letzterer nach hinten zu allmählich dunkler. Kopfschild und Stirn sehr fein gewirkt und verloschen punktiert, die Trennungslinie zwischen beiden und die Augenrinnen schmal, doch scharf und tief. Thorax halb so breit als die Flügeldecken, hinten fast dreimal so breit als lang, nach vorn in mässiger Rundung stark verengt, oben schwach querüber gewölbt, aber in den Vorderwinkeln stärker abfallend, dicht punktiert. Die Punkte sind nabe dem Vorderrande und auf einem grösseren Raume in den Vorderecken flach, verloschen und weiter auseinander gerückt. Schildchen gross, flach, hinten kurz, doch scharf zugespitzt, zart gewirkt. Flügeldecken mit regelmässigen feinen, aber scharfen und tiefen Streifen, in denen sehr kleine Punkte stehen. Letztere fallen dadurch mehr in die Augen, dass ihre nächste Umgebung dunkel durchscheint. Der erste (abgekürzte) Streifen ist mässig lang, der siebente und der achte sind vorn nach innen gebogen und dann nahe der Schulterbeule abgekürzt, der neunte und zehnte vereinigen sich weit hinter der Schulter mit einander, der elfte nähert sich dicht hinter der Schulter dem achten bedeutend. Der abgesetzte Seitenrand ist dachförmig, ähnlich wie bei den Cassiden, beim φ kaum ein drittel so breit, beim δ ziemlich so breit als die Scheibe der Flügeldecken und fällt mit der Scheibe fast in einer Flucht ab. Er ist nicht dicht punktiert, die Punkte scheinen bei gewissem Lichte dunkel durch. Beim δ sind die Tarsen der Vorderbeine etwas erweitert.

5. CORYNODES INDAGACEUS Chev., Rev. et Mag. Zool. (1841), 228.

LUZON, Province of Benguet, Irisan River, P. I. (1300 R. C. McGregor).

6. COLASPOSOMA species.

7. AULACOPHORA QUADRIMACULATA Chap., Ann. Soc. Ent. Belg., Bull. (1876), 19, 100.

NEGROS OCCIDENTAL, Maa; LUZON, Province of Rizal, Montalban Gorge, P. I. (277, 5564 C. S. Banks).

8. AULACOPHORA ROSEA Chap., Ann. Soc. Ent. Belg., Bull. (1876) 19, 99.

LUZON, Province of Benguet, Irisan River, P. I. (1299 R. C. McGregor).

*9. HOPLASOMA PHILIPPINENSIS Jac., Ann. Soc. Ent. Belg. (1894), 197.

Der Bauch ist nur in der Mitte schwarz, an den Seiten blass gelblich gesäumt, der erste Bauchring ganz, sowie der Hinterrand der folgenden Ringe gelblich. Der zweite Ring trägt in der Mitte einen breiten, dicken pechschwarzen Anhang, der hinten in zwei lange, dicke, allmählich zugespitzte Zähne endet. Diese sind an der Spitze rötlich gelb, der

ganze Anhang ist dicht gerunzelt, sehr dicht behaart und erscheint daher rauh. Die *Hoplasomen* lassen sich überhaupt an der mannigfaltigen Bildung des Bauchanhanges beim ♂ sicher unterscheiden.

LUZON, Province of Pampanga, Mount Arayat, P. I., 2,500 feet (2977 W. *Williamson*).

In Allard's Tabelle, Ann. Soc. Ent. Fr. (1888) 327, ist die Angabe unter *g*¹: "Philippines 5. *picifemora* All." an eine falsche Stelle geraten; sie muss hinauf an den Satz unter *g* gerückt werden, wonach die Anmerkung Jacoby's, Ann. Soc. Ent. Belg. (1896) 271 unten und p. 272 unter *H. abdominalis* zu berichtigen ist. Zugleich muss in dieser Arbeit, pp. 271–273 für *Haplosoma* immer *Hoplasoma* gelesen werden.

10. HAPLOSOMYX SPECIOSUS Baly., Ann. Mag. Nat. Hist. (1879), (5) 3, 113.
Ein Exemplar mit einfarbig weisslichgelben Fühlern.

SIBUYAN ISLAND, P. I. (2001 R. C. *McGregor*).

11. HAPLOSOMYX ?SMARAGDIPENNIS Chev., Rev. Zool. (1839) 288.

LUZON, Province of Benguet, Irian River, P. I. (1070 R. C. *McGregor*).

*12. CNECODES SUTURALIS Motsch., Etud. Ent. (1858) 100.

Ein ♀. Von Birma beschrieben, über Vorder- und Hinterindien, China, etc., verbreitet. Das ♀, welches der Autor nicht erwähnt, hat in der Regel nur Glied 8 und 9 der Fühler weisslich.

LUZON, Manila, P. I. (4868 C. S. *Banks*).

13. MENIPPUS VIRIDIS Duvivier, Ann. Soc. Ent. Belg., Bull. (1884), 28, 315.

NEGROS-OCCIDENTAL, Maaao, P. I. (327 C. S. *Banks*).

14. *Monoleppta* (*Candezea*) *bifoveolata* sp. nov.

♂ Oblongata, fulvo-rufa, nitida, antennis articulis 3–7 nigris, 8–11 flavis, articulo ultimo apice infuscato, tibiis apice tarsisque infuscatis, capite laevi, prothorace subquadrato obsolete punctulato, clytris subtilissime punctatis, singulo fovea sublaterali ante medium impressis.—Long. 5.8 mm.

MINDORO, Rio Baco, P. I. (R. C. *McGregor* collector).

Type No. 3393 in der Entomologischen Sammlung des Bureau of Science, Manila, P. I.

Die Fühler sind ziemlich so lang als der Körper, Glied 3 ist doppelt so lang als 2, 4 länger als 3 und etwas kürzer als 1, die folgenden sind dem 4ten ähnlich; die beiden ersten Glieder sind rostrot gefärbt wie der Körper, 3–7 nicht besonders tief schwarz, 8–11 weisslichgelb, die Spitze des letzten Gliedes und der Schienen, sowie die Tarsen angedunkelt. Thorax wenig breiter als lang an den Seiten hinter der Mitte leicht verengt, auf der Scheibe verloschen und sehr fein punktiert, in der Mitte jederseits leicht eingedrückt. Schildchen glatt. Flügeldecken an der Basis nicht ganz doppelt so breit wie der Hinterrand des Thorax, bis ein viertel der Länge leicht erweitert, dann ziemlich parallel, im letzten

Viertel wieder etwas verengt und hinten gerundet abgestutzt; sehr fein punktiert und in den Zwischenräumen mit zahlreichen noch feineren Pünktchen besetzt. Jede Decke hat hinter dem ersten Viertel der Länge über dem Seitenrande eine gerundete Grube, deren Umgebung etwas wulstartig erhöht, äusserst dicht und fein punktiert und ziemlich matt ist. Die Grube ist tief, aber viel kleiner wie beim ♂ von *cavipennis* Baly. Hinterschienen mit mässig langem Enddorne, Metatarsus beinahe halb so lang als die Schiene.

15. *SPHAERODERMA* species.

Ein Exemplar, einer gelbbraunen Art, deren Fühler vom fünften Gliede ab schwärzlich gefärbt sind.

*16. *PSYLLIODES SPLENDIDA* Harold, Deutsche Ent. Zeit. (1877), 364.

LUZON, Manila, P. I. (2466 C. S. Banks).

*17. *PHYLLOTRETA SERRICORNIS* Duviv., Stett. Ent. Zeit. (1885), 46, 387.

Ein ♀. Nach der Grösse, Färbung und namentlich nach der Form der weissen Längsbinde jeder Flügeldecke dürfte das vorliegende Exemplar zu dieser Art gehören, die nur nach dem ♂ beschrieben ist. Beim ♀ sind die Fühler einfach, Glied 2 und 3 klein, 3 unbedeutend länger als 2, 4 und die folgenden dicker als die beiden vorhergehenden, allmählich bis zum 6ten Gliede verbreitert, dann gleichbreit, Glied 4 so lang als 2 und 3 zusammen, 5 und die folgenden etwa 1/2 so lang als 4, nur das Endglied etwas länger.

NEGROS OCCIDENTAL, Nakalang, P. I. (1148 C. S. Banks).

*18. *Blepharida manilensis* sp. nov.

Elongata, dilute ferruginea, elytris citrinis, ferrugineo-vel brunneo-variegatis, prothorace ante medium dilatato, hic illic parce punctato, basi sulco brevi, antice sulco longo apice bifurcato impresso, prosterno basi subtruncato. Long. 11–12 mm.

SIBUYAN ISLAND, P. I. (R. C. McGregor collector).

Type No. 1913 in der Entomologischen Sammlung des Bureau of Science, Manila, P. I.

Nach der Beschreibung mit *Bl. flavopustulata* Baly von Assam am nächsten verwandt, aber der Thorax mit gut ausgeprägten punktierten Furchen versehen, ähnlich wie bei der kleineren *Bl. xanthospilota* Baly aus China.

Der Körper ist schlank gebaut, namentlich beim ♂, hell rotbraun, die vier Vorderbeine und die Fühler blasser, die Flügeldecken citronen- oder weisslichgelb, mit zahlreichen, unregelmässigen rotbraunen Flecken bestreut, welche teilweise der Quere nach, oder schräg unter einander verbunden sind; die Punkte in den regelmässigen Reihen ebenfalls rotbraun: Zuweilen nimmt die dunkle Färbung so zu, dass auf der Scheibe nur zahlreiche kleine, gelbe Fleckchen übrig bleiben, während

die Basis fast zusammenhängend gelb gefärbt ist und auch der letzte Zwischenstreifen zwei grössere gelbe Makeln trägt. Die Stirn ist sehr fein punktiert, die gebogenen Stirnrinnen sind tief und scharf und setzen die glatten Beulen über der Fühlerwurzel scharf ab. Thorax mehr als doppelt so breit wie lang, die Seiten von der Basis bis zur Mitte ziemlich parallel, dann im Bogen erweitert und nach den Vorderecken wieder verengt, letztere wie gewöhnlich nach aussen vortretend. Die Scheibe ist vor der Mitte fast glatt, unter stärkerer Vergrösserung zart punktuert, hinter derselben jederseits von der Mittellinie mit einer Gruppe von kräftigen Punkten versehen; die Furchen sind tief, die an der Basis kurz, glatt, die vom Vorderrand ausgehenden lang, punktiert, noch vor der Mitte des Thorax gegabelt, ein Ast läuft gradlinig bis in den Seitenrand, der andere schräg nach hinten und innen. Die Punktstreifen der Flügeldecken sind wenig tief, die Zwischenstreifen fast glatt, eben.

19. *ASPIDOMOPHA MILLARIS* Fabr., Syst. Ent. (1775) 91.

Die hellste Form, aberration *flaveola*, liegt von den Philippinen zwar nicht vor, dürfte dort aber kaum fehlen, da sie überall mit der Stammform zugleich auftritt. Bei ihr besitzen die Flügeldecken nur wenige, kleine, punktförmige, schwarze Flecken, das Seitendach ist ganz ungefleckt, oder hat zwei bis fünf schwarze Punkte: 1, hinter der Basis, neben der Schulterbeule, 2 und 3 dahinter, neben einander nahe dem Ausserrande, und zwei ähnliche (4 und 5) hinter der Mitte, alle frei.

Übergänge zur typischen Form, bei der auf dem Dache 2 schwarze Querbänder liegen, bilden solche Stücke, bei denen entweder der 2te und 3te, oder der 4te und 5te Fleck sich der Quere nach vereinigt haben.

Häufig scheinen bei Manila Übergänge zur dunkelsten Form, der aberration *inundata*, zu sein, bei welcher zuletzt die Flügeldecken tief schwarz sind, ausgenommen ein grosser Fensterfleck auf dem Dache, von ein viertel der Länge bis hinter die Mitte, und eine kleine, gemeinschaftliche gelbe Makel am Schildchen. Stücke bei denen ausserdem das Seitendach im letzten Viertel, oder eine gemeinschaftliche Makel in der Mitte der Flügeldecken, oder noch mehrere punktförmige Makeln auf der Scheibe jeder Decke gelb sind, können ebenfalls schon zu dieser Farbenabänderung gerechnet werden.

20. *ASPIDOMORPHA* species.

Ein ♂ aus der Verwandtschaft von *dorsata* und *bilobata*, aber von diesen Arten durch längere Endglieder der Fühler verschieden. Bei den hierher gestellten Species hat Boheman ausser kleinen Farbenabweichungen eigentlich keine positiven Unterschiede genannt und sie bedürfen daher einer gründlichen Bearbeitung.

*21. *Lacoptera manilensis* sp. nov.

Subtriangularis, convexa, rufo-testacea, subopaca, antennis articulis 5 ultimis pectoreque macula postica utrinque nigris, prothorace in disco subtiliter aciculato-punctato, nigro bimaculato, elytris crebre-, interne substriato-punctatis et bicarinulatis, macula subscutellari communi maculisque sex rotundatis in singulo nigris, protecto deflexo, crebre sat fortiter punctato.—Long. 7–7.5 mm.

Aberration a. *nigripennis*.

Elytris nigris, protecto maculis duabus rufescentibus, prima baseos, secunda in medio.

Luzon, Province of Benguet, Irisan River, P. I. (*R. C. McGregor* collector).

Type No. 6360 in der Entomologischen Sammlung des Bureau of Science, Manila, P. I.

Körpergestalt von *L. tredecimpunctata* Fabr., aber nach hinten etwas mehr verengt, auf den Flügeldecken ohne einen gemeinschaftlichen kleinen Höcker in der Spitze des Basaldreieckes und durchweg feiner punktiert, nur die zwei ersten Punktreihen sind ziemlich regelmässig, die beiden folgenden schon sehr gestört und die übrigen ganz verworren, auch die Zeichnung ist abweichend, namentlich dadurch, dass die vordere Randmakel und die daneben liegende Makel 3 nahe der Mitte der Scheibe gross und gerundet sind; *L. philippinensis* Boh. ist etwas glänzender als die vorliegende Art, auf den Flügeldecken ähnlich punktiert und mit der gleichen Zahl schwarzer Flecken gezeichnet, aber das Seitendach fällt weniger ab, ist weitläufiger und viel flacher punktiert und neben der Schulter, sowie zwischen den beiden Randmakeln convex aufgetrieben, ausserdem hinter der zweiten Makel weniger verengt aber tiefer von der Scheibe abgesetzt und die erste Randmakel tritt kaum auf das Dach hinaus.

Flügeldecken in den Schultern am breitesten, hierauf allmählich verengt und hinten gemeinschaftlich schmal abgerundet; auf ihnen befinden sich zusammen dreizehn gerundete schwarze Makeln, eine gemeinschaftliche vor der höchsten Stelle der Decken, breiter als lang, sowie sechs auf jeder Flügeldecke. Hiervon liegt Makel 1 auf dem vorderen Teile der Schulterbeule, 2 in der Seitengrube vor ein drittel der Länge, mit dem grössten Teile auf dem Seitendache, 3 und 4 bilden mit ihr eine Schrägreihe nach hinten und innen, 3 ist gross, innen von der zweiten Rippe begrenzt, oder wenig darüber hinwegreichend, 4 klein, auf der ersten Rippe, 5 und 6 bilden eine weniger schräge, zuweilen fast grade Querreihe. Makel 5 befindet sich unmittelbar vor zwei drittel der Länge auf dem Dache und reicht nur wenig auf die Scheibe hinauf, 6 zwischen der zweiten Rippe und der Naht.

Öfter verbindet sich Makel 3 mit 4; äusserst selten (Herr Schultze fand unter Hunderten von Exemplaren nur ein Stück) sind die Flügel-

decken schwarz, eine grosse, ziemlich dreieckige Makel in der Schulterecke, sowie der Raum des Daches zwischen den Normalmakeln 2 und 5 rotbraun. (ab. *nigripennis*).

Zwei ähnlichen Arten von Niederländisch Ostindien scheinen ebenfalls unbekannt zu sein:

22. *Lacoptera insulana* sp. nov.

Breviter ovalis, convexa, testacea, nitidula, antennis articulis 5 ultimis pectoreque utrinque macula postica nigris, prothorace disco obsolete reguloso-punctato, nigro-bimaculato, elytris crebre et fortiter punctato-striatis, rugosis, nigro-irroratis, protecto crebre rugoso, nigro-bimaculato. Long. 7 mm.

INSULA WETTA, Niederländisch Ostindien April, 1901.

Diese Art von der ich fünf Exemplar von Herrn Hauptmann Moser erhielt, und noch andere sah, lässt sich mit der mir unbekanntem *sculpturata* Boh., aus Celebes nicht vereinigen, weil die drei Gruben an der Basis der Flügeldecken, die Boheman ausführlich beschreibt, nicht vorhanden sind, und die Körperform und die Zeichnung abweicht.

Der Umriss ist länglich oval, indem die Flügeldecken an der Basis nur mässig breiter sind als der Thorax, sich im ersten Viertel etwas erweitern, dahinter gradlinig und sehr wenig verschmälern, und erst im letzten Drittel stärker gerundet-verengt und hinten breit abgerundet sind. Auf der Scheibe sind sie stark in Reihen punktiert, die an einigen Stellen durch Querrunzeln gestört werden, welche die sehr schmalen, erhöhten Zwischenstreifen verbinden. Das Seitendach ist dicht querrunzelig, ohne deutlich hervortretende Punkte.

Hell rötlich gelbbraun, das Seitendach gelblich, die beiden schwarzen Makeln des Thorax ziemlich gross, auf jeder Decke sind fünf regelmässige Makeln, zwei auf dem Seitendache, gross und drei vor der Mitte der Scheibe, kleiner. Die erste Dachmakel liegt bald hinter der Schulterecke am Seitenrande, ist dreieckig, nach innen zugespitzt, und erreicht hier die 10te Punkteihe vor der normalen tiefen Grube. Über dieser liegt zwischen der 9ten und 6ten Reihe die dritte Scheibenmakel, die gewöhnlich etwas breiter als lang ist. Die beiden andern Scheibenmakeln sind gerundet, 1 vor der Schulterbeule, 2 vor der Spitze des Basaldreieckes, in der Regel frei. Ausserdem ist die Scheibe hinter der Mitte unregelmässig mit kleinen schwarzen Flecken bestreut, die aus der Vereinigung von 2 bis 3 schwarz gefärbten Punkten entstehen, auch der Spitzenwinkel ist mehr oder weniger breit schwarz. Die zweite Dachmakel liegt normal, reich vom Seitenrande bis zum 10ten Punktstreifen und ist meist viereckig.

23. *Lacoptera fallax* sp. nov.

Subrotundata, convexa, rufo-testacea, nitidula, protecto flavescente, antennis articulis 5 ultimis et plerumque maculis duabus metasterni nigris; prothorace disco sublaevi, nigro-bimaculato, elytris in disco crebre

et fortiter punctato-striatis, maculis parvis cerciter 22 signatis, protecto fortiter rugoso-punctato, maculis duabus magnis nigris, postica in discum nonnihil excurrente.—Long. 8 mm.

INSULA LARAT vel TENIMBER Niederländisch Ostindien (*Moser*).

Der vorigen sehr ähnlich und nahe verwandt, jedoch breiter gebaut und an den Seiten mehr gerundet, die Scheibe des Thorax fast glatt, das Seitendach dagegen stark und tief runzelig punktiert und die zweite Makel desselben bis in die 9te Punktreihe reichend und auf dem letzten Zwischenstreifen nach vorn ausgezogen. Die drei ersten Scheibenflecke sind ähnlich, nur liegt der erste mehr auf der Schulterbeule und weiter von der Basis entfernt, dahinter befinden sich noch acht kleine schwarze Flecken: zwei in der Mitte neben einander, drei hinter derselben und drei auf dem Abfalle zur Spitze. Diese selbst ist ebenfalls schwarz.

24. METRIONA TRIVITTATA Fabr., Syst. Eleuth. (1801) 1, 397.

Wurde auch von Herrn Ribbe bei Manila häufig gefangen.

LUZON, Manila, P. I. (304 W. *Schultze*).

25. PROMECOTHECA CUMINGI Baly, Cat. Hispid. (1858) 88.

Da die Färbung der hellen Hispinen oft erheblich variiert, rechne ich das vorliegende ♂ noch zu dieser Art. Es ist 8 mm. lang, rostrot, Flügeldecken blässbräunlich gelb, die letzten drei bis vier Fühlerglieder schwärzlich. Alle acht Punktreihen der Flügeldecken sind durchaus regelmässig, nur schiebt sich zwischen Reihe 5 und 6 vor der Mitte noch eine überzählige Reihe, die auf der Schulterbeule beginnt. Der Zahn an den vier Vorderschenkeln ist klein, breit, stumpf, der an den langen Hinterschenkeln grösser, spitz, und bedingt eine ziemlich tiefe, bogenförmige Ausrandung in den Hinterschienen.

LUZON, Manila, P. I. (2448 C. S. *Banks*).

*26. AGONIA VANDEPOLLI Gestro, Ann. Mus. Genova (1877) 38, 120.

Ein Exemplar; heller als normal gefärbt, der Bauch einfarbig rostrot, die Flügeldecken an der Spitze mit einem kleinen schwärzlichen Wische. Innen sind die beiden ersten Fühlerglieder rötlich.

LUZON, Manila, P. I. (2621 C. S. *Banks*).

27. DACTYLISPA CLADOPHORA Guér., Rev. Zool. (1841), 7.

LUZON, Manila, P. I. (2138 W. *Schultze*).

II. COCCINELLIDEN.

*28. EPILACHNA PUSILLANIMA Muls., Spec. (1851), 784.

LUZON, Manila, P. I. (248 C. S. *Banks*).

29. EPILACHNA VIGINTIOCTO-PUNCTATA Fabr., Syst. Ent. (1775), 84.

LUZON, Manila, P. I. (2236 C. S. *Banks*).

30. HARMONIA OCTO-MACULATA Fabr., Spec. Ins. (1781), 1, 97, und deren ab. PHILIPPINENSIS Muls.

LUZON, Manila, P. I. (1376 and 2874, W. Schultze).

*31. THEA CINCTA Fabr., Ent. Syst., Suppl. (1798), 77.

LUZON, Manila, P. I. (2137 W. Schultze).

*32. COELOPHORA VIDUA Muls., Spec. (1851), 393.

Var.? 1 Exemplar in der Färbung mit *Synia melanaria* Muls., übereinstimmend: Oberseite schwarz, glänzend, der Mund und ein feiner Saum des Kopfschildes, ein nicht breiter Saum in den Vorderecken des Thorax (vom inneren Augenrande bis zur Mitte des Seitenrandes reichend) nebst Fühlern, Beinen und der Unterseite (die Epipleuren der Flügeldecken ausgenommen) rötlich gelbbraun. Die Punktierung der Oberseite ist feiner wie in der typischen *vidua*.

LUZON, Manila, P. I., (752 W. Schultze).

*33. *Coelophora personata* sp. nov.

Subhemisphaerica, nigra, nitida, fronte utrinque tarsisque testaceis, prothorace subtilius punctato, limbo angusto apicali maculaque magna laterali albides, elytris coccineis, macula rotunda subhumerali, fascia communi pone medium limboque suturali utrinque abbreviato nigris.

Mas: capite albedo, pedibus anticis testaceis. Long. 4-5.5 mm.

LUZON, Manila, P. I. (C. S. Banks collector).

Type No. 2678 in der Entomologischen Sammlung des Bureau of Science, Manila, P. I.

An der Zeichnung der Flügeldecken sofort zu erkennen. Dieselben sind lebhaft und glänzend gelblich rot gefärbt, eine runde Makel nahe der Basis an der Innenseite der Schulterbeule, eine gemeinschaftliche Querbinde hinter der Mitte sowie ein Naht- und oft auch ein Seitensaum schwarz. Die Querbinde ist gerade, ziemlich von gleicher Stärke und dehnt sich bis zum Seitenrande aus, seltener erreicht sie denselben nicht ganz. Mit ihr ist der Nahtsaum verbunden, der sich vorn, nahe dem Schildchen, teilt und jederseits etwas von der Naht entfernt; jeder Ast bleibt von der Basis und der Schultermakel ungefähr gleichweit getrennt. Der Seitensaum ist rot-, oder pechbraun und reicht von der Basis bis neben, oder wenig hinter die Querbinde.

Taster und Fühler rötlich gelbbraun, Kopf beim ♂ weisslich, beim ♀ schwarz, Vorderrand der Oberlippe und eine Längsmakel der Stirn jederseits rötlich gelbbraun. Thorax schwarz, ein Saum des Vorderandes und eine damit verbundene grosse Makel in den Vorderecken, innen bogenförmig ausgerandet und hinten gerundet, nicht ganz die Basis erreichend, gelblich weiss. Schildchen schwarz, in der Mitte oft rötlich durchscheinend. Unterseite und Beine schwarz, Epipleuren der Flügeldecken, Seiten der Vorderbrust und des Bauches nebst der Tarsen (beim ♂ auch die Vorderbeine) rötlich gelbbraun, Epimeren der Mittel- und Hinterbrust gelb.

*34. *Coelophora schultzei* sp. nov.

Subhemisphaerica, dilute fulva, nitida, fronte, lateribus prothoracis guttisque 12 elytrorum, 1, 2, 2, 1 collocatis, albidis. Long. 5 mm.

LUZON, Manila, P. I. (*C. S. Banks* collector).

Von den sechs gelblich weissen Tropfen jeder Flügeldecke liegen drei, nämlich 1, 2, 4, in einem Bogen hinter einander innen, die andern drei in einem schwächeren Bogen am Seitenrande, die inneren sind kleiner, die äusseren grösser. Der erste Tropfen befindet sich an der Basis nahe dem Schildchen, der zweite viel weiter von der Naht abgerückt in ein drittel der Länge, etwas schräg nach hinten und innen von 3, welcher unmittelbar am Seitenrande liegt und schwach quer ist. Tropfen 4 und 5 bilden mit dem entsprechenden Tropfen der anderen Decke eine grade oder nach vorn leicht convexe Querreihe wenig hinter der Mitte, 6, in der Spitze, ist der grösste von allen. Am Thorax ist ungefähr das äussere Viertel gelblich weiss gefärbt.

Es macht mir besonderes Vergnügen, diese hübsche Art Herrn W. Schultze in Manila widmen zu können.

35. *CHILOMENES SEXMACULATUS* Fabr., Spec. Ins. (1781) 1, 96.

LUZON, Manila, P. I. (264 *W. Schultze*).

36. *HETERASPIS BILLARDIERI* Crotch, List Coccinel. (1871), 6; (*reticulata* Fabr.) Syst. Eleut. (1801), 1, 362.

LUZON, Manila, P. I. (2087 *W. Schultze*).

37. *SYNONYCHA GRANDIS* Thunb., Nov. Ins. Spec. (1781), 12.

LUZON, Manila, P. I. (2136 *W. Schultze*).

*38. *VERANIA NIGRILABRIS* Muls., Monogr. Coccin. (1866), 73.

Var.? Die Oberlippe ist nicht schwarz, sondern hell gefärbt wie der ganze Körper, der Bauch nur in der Mitte der ersten Segmente dunkler, gebräunt.

LUZON, Manila, P. I. (266 *P. L. Stangl*).

*39. *CHILOCORUS CERBERUS* Muls., Opusc. (1856), 148.

LUZON, Manila, P. I. (1356 *C. S. Banks*).

*40. *BRUMUS SUTTURALIS* Fabr., Ent. Syst., Suppl. (1793), 78.

LUZON, Manila, P. I. (3765 *C. S. Banks*).

*41. *CRYPTOGONUS ORBICULUS* Gyllh., Schönh., Synon. Ins. (1808), 1, 2, 205.

LUZON, Manila, P. I. (4738 *C. S. Banks*).

THE BONTOC IGOROT.

Order No. 401.

By A. E. JENKS.

110 pages. 3 maps. 154 photographic plates. 9 figures.

An interesting study; the result of almost a year's residence among the Bontoc Igorots.

Price \$1 United States currency, postpaid.

NEGRITOS OF ZAMBALES.

Order No. 402.

By WILLIAM ALLAN REED.

62 photographic illustrations. 91 pages.

An interesting ethnological study of the pygmy blacks of Zambales.

Price \$0.25, United States currency, postpaid.

THE NABALOI DIALECT.

Order No. 403.

By OTTO SCHEERER.

TOGETHER WITH

THE BATAKS OF PALAWAN.

By EDWARD Y. MILLER.

199 pages. 1 map. 28 full-page photographic plates. 6 figures.

The result of research work among this interesting tribe of primitive people.

Price \$0.25, United States currency, paper, postpaid.

NOTE.

Orders should be sent to the Business Manager, Philippine Journal of Science, Manila, or to any of the below-listed agents. *Please give Order Number.*

FOREIGN AGENTS.

The Macmillan Company, 64-66 Fifth Avenue, New York City, U. S. A.
Messrs. Wm. Wesley & Son, 28 Essex Street, Strand, London, W. C., England.
Mr. Martinus Nijhoff, Nobelstraat 18, The Hague, Holland.
Messrs. Mayer & Muller, Prinz Louis Ferdinandstrasse 2, Berlin, N. W., Germany.
Messrs. Kelley & Walsh, Limited, 32 Raffles Place, Singapore, Straits Settlements.
Messrs. A. M. & J. Ferguson, 19 Baillie Street, Colombo, Ceylon.

CIRCULARS AND DESCRIPTIVE MATTER SENT ON APPLICATION.

Beginning with Volume V, a new section, "Section D, Ethnology, Anthropology, and General Biology," will be added to the Journal. The price for the whole series to subscribers for 1910 will be as heretofore, \$5 United States currency. Single subscriptions to Section D will be \$2 United States currency.

Beginning with 1911, the price of the entire Journal will be increased to \$7 United States currency. Section D will appear as often as material is available.

CONTENTS.

	Page.
SEALE, ALVIN. The Fishery Resources of the Philippine Islands. Part III. Pearls and Pearl Fisheries	87
MCGREGOR, RICHARD C. Birds Collected in the Island of Polillo, Philippines	103
SEALE, ALVIN. Descriptions of Four New Species of Fishes from Bantayan Island, Philippine Archipelago	115
FOREL, A. Fourmis des Philippines	121
BANKS, CHARLES S. A New Accessory for Dissection Work	131
MCGREGOR, RICHARD C. Birds from Pauai and Mount Pulog, Sub-province of Benguet, Luzon	135
WEISE, J. Verzeichniss Von Coleopteren Aus Den Philippinen, Nebst Zwei Neuen Arten Aus Niederlandisch Ostindien	139

The "Philippine Journal of Science" is issued as follows:

Section A, Chemical and Geological Sciences and the Industries, \$2 United States currency per year.

Section B, Medical Sciences, \$3 United States currency per year.

Section C, Botany, \$2 United States currency per year.

Section D, Ethnology, Anthropology, and General Biology, \$2 United States currency per year.

The entire "Journal," \$5 United States currency for Volumes II, III, IV, and V. Thereafter, \$7 United States currency per year.

Authors receive 100 copies of their papers free.

Subscriptions should be sent to the Business Manager, Philippine Journal of Science, Bureau of Science, Manila, P. I., or to any of the agents listed below. Please give order number.

FOREIGN AGENTS.

The Macmillan Company, 64-66 Fifth Avenue, New York City, U. S. A.

Messrs. Wm. Wesley & Son, 28 Essex Street, Strand, London, W. C., England.

Mr. Martinus Nijhoff, Nobelstraat 18, The Hague, Holland.

Messrs. Mayer & Muller, Prinz Louis Ferdinandstrasse 2, Berlin, N. W., Germany.

Messrs. Kelley & Walsh, Limited, 32 Raffles Place, Singapore, Straits Settlements.

Messrs. A. M. & J. Ferguson, 19 Baillie Street, Colombo, Ceylon.

A limited number of unbound copies of previous volumes are available, which may be secured from the Business Manager, Philippine Journal of Science, Manila, P. I., at the following rates: Volume I, 1906 (not divided into sections), \$10 United States currency; Supplement to Volume I, \$3.50 United States currency; Volume I (without supplement), \$6.50 United States currency; all later volumes at current subscription prices.

Vol. V

AUGUST, 1910 No. 3

THE PHILIPPINE
JOURNAL OF SCIENCE

EDITED BY

PAUL C. FREER, M. D., PH. D.

WITH THE COOPERATION OF

DEAN C. WORCESTER, A. B.; ROBERT BENNETT BEAN, M. D.
MERTON L. MILLER, PH. D.; CHARLES S. BANKS, M. S.
ALVIN SEALE, A. B.; LAWRENCE E. GRIFFIN, PH. D.
RICHARD C. MCGREGOR, A. B.; NELLIE LOUISE COOK, B. L., M. A.

PUBLISHED BY

THE BUREAU OF SCIENCE

OF THE

GOVERNMENT OF THE PHILIPPINE ISLANDS

D. ETHNOLOGY, ANTHROPOLOGY, AND GENERAL
BIOLOGY



MANILA
BUREAU OF PRINTING
1910



Order No. 405.

STUDIES IN MORO HISTORY, LAW, AND RELIGION.

By NAJEEB M. SALEEBY.

107 pages. 16 illustrations. .5 diagrams.

A treatise on the history and customs of the Moro People.

Price \$0.25, United States currency, postpaid.

Order No. 406.

THE HISTORY OF SULU.

By NAJEEB M. SALEEBY.

275 pages.

A complete History of the Moro People in Sulu, with maps and many translations from the original documents.

Price \$0.75, United States currency, postpaid.

Order No. 410.

MINDANAO.

THE SUBANUNS OF SINDANGAN BAY.

By EMERSON B. CHRISTIE.

122 pages.

Profusely illustrated.

This, together with the History of Sulu and the Studies in Moro History, Law and Religion, is one of an authentic and valuable set of works on the origin, history and customs of these tribes, who are among the most interesting peoples of the world.

Price \$1.25, United States currency, postpaid.

NOTE.

Orders should be sent to the Business Manager, Philippine Journal of Science, Manila, or to any of the below-listed agents. *Please give Order Number.*

FOREIGN AGENTS.

The Macmillan Company, 64-66 Fifth Avenue, New York City, U. S. A.
Messrs. Wm. Wesley & Son, 23 Essex Street, Strand, London, W. C., England.
Mr. Martinus Nijhoff, Nobelstraat 18, The Hague, Holland.
Messrs. Mayer & Muller, Prinz Louis Ferdinandstrasse 2, Berlin, N. W., Germany.
Messrs. Kelley & Walsh, Limited, 32 Raffles Place, Singapore, Straits Settlements.
Messrs. A. M. & J. Ferguson, 19 Baillie Street, Colombo, Ceylon.

CIRCULARS AND DESCRIPTIVE MATTER SENT ON APPLICATION.

THE PHILIPPINE JOURNAL OF SCIENCE

D. ETHNOLOGY, ANTHROPOLOGY, AND
GENERAL BIOLOGY

VOL. V

AUGUST, 1910

No. 3

THE PEARL FISHERY OF BANTAYAN.¹

By LAWRENCE E. GRIFFIN.²

The Island of Bantayan lies between the northern ends of Negros and Cebu, at the head of the Tañon Channel. It is about 11 kilometers wide and 18 kilometers long. A string of islets, sometimes called the Don Islands, stretches 13 or 14 kilometers from its southwestern corner toward Negros. A single islet is located about 13 kilometers north of the outermost of the Dons. These islands, Bantayan on the east, the Dons on the south, and the last islet to the northwest, bound a shoal about 260 square kilometers in area. On the east and south of Bantayan, and south of the Dons, the shallow water extends for from 1 to 2 kilometers and then gradually deepens. At only one point, Santa Fé, on the southeast corner of Bantayan, does the water deepen suddenly. This is the only place where large boats can come to within half a kilometer of the main island. Almost all the small islands are inhabited, but their total population being is not much more than 1,000; that of Bantayan Island is over 37,000.

The islands are formed entirely of coral, all except Bantayan being flat, with an elevation not exceeding 5 meters. Curiously enough, the outermost of the Dons, Lipayran, is densely covered with virgin forest of first-group woods; the other islands have few trees except the coconut.

The passages between the Don Islands are all shallow, except between

¹ Contribution from the Biological Laboratory, Bureau of Science, Manila, P. I.

² Associate professor of zoölogy, Philippine Medical School, Manila, P. I.

the last two, Doong and Lipayaran, where the channel is at least 4 fathoms deep. At the rise and fall of every tide, the water pours through these passages, at one place making whirlpools which are much feared by the pearl divers and fishermen. A strong current sweeps over the entire shoal.

During the months of May, June, November, and December, when usually the winds are light and calms prevail, the water is so clear that the bottom can plainly be seen in eight fathoms. At such times the divers float around over the shoal looking for pearl shells. There is nothing here that can be called a pearl bank, such as is found near Mindanao, Jolo, or Ceylon. The pearl shells are scattered singly over the sandy bottom, and it is a rare occurrence for a diver to be so fortunate as to find half a dozen shells in a day's search; he is generally satisfied with one or two shells in a day. As a compensation for the small number of shells, the number of pearls found is proportionally very high and their quality good.

One pearl found this year was valued at 800 pesos (400 dollars United States currency); others, worth from 200 to 500 pesos (100 to 250 dollars United States currency) have not been rare. One of the Bantayan pearls was sold in Cebu about three years ago for 800 pesos (400 dollars United States currency). The mother-of-pearl gathered at Bantayan and disposed of to the local dealers for the year 1908 was worth 1,548 pesos (774 dollars). The pearls bought by the same dealers during this period were worth 4,584 pesos and 50 centavos (2,292 dollars and 25 cents United States currency). The *presidente* of Bantayan estimates that mother-of-pearl and pearls of about half this value are sold in such a way that there is no record of them. The total value of the pearl fisheries at this place is then not far from 9,000 pesos (4,500 dollars United States currency) per annum. The competition among the local Chinamen is so great that the prices for shell are almost equal to those paid in Cebu.

The shells are generally second grade in size, but of good quality. The search for them during the favorable season is so keen that the full-grown oysters have nearly all been gathered. If the shoal were smaller or the season longer, the pearl oyster would have disappeared long ago from this place.

The municipal council recently has passed an ordinance regulating the size of shells which may legally be taken. While this is the proper thing for the council to do, it is doubtful if the ordinance will have the slightest effect upon the pearl fishery.

This pearl fishery of Bantayan is illustrative of many native Philippine industries: while collectively bringing considerable money into the municipality and increasing to that extent the income of a part of the population, there is not the slightest chance of its attracting capital to Bantayan or of its being expanded by any modern method of working. However, Bantayan seems to be an ideal place for experiments in the

artificial culture of pearl oysters. If a practical method³ of rearing the young oysters through the larval period to the time when they settle upon the bottom, and also for planting them over this great shoal could be discovered, the value of the Bantayan pearl fishery would be multiplied many hundred times, for every part of the shoal seems equally adapted to the needs of the oyster.

The pearl button factories of the United States for many years have been using the shells of clams found in the Mississippi River and its tributaries. These, once so numerous, are reduced now to such an extent that the industry is in danger of extinction. A knowledge of these facts led Prof. W. C. Curtis in 1898 to commence a study of the development of the clams and to experiment in rearing them under artificial conditions. Later he was joined in this work by Prof. George Lefevre. The experiments have reached a stage where they promise success, and lately the United States Fish Commission has built a laboratory on the upper Mississippi to enable these two men to carry on their experiments on a larger scale.

We have similar conditions affecting the pearl fisheries in the Philippines. Pearl shells are found in limited numbers in nearly all parts of the Archipelago. They are of a finer quality than the Ceylon or Persian shells, and consequently available for an immense variety of uses. All requisites for the growth of the oyster seem to be favorable, excepting some condition affecting the young at the time when they cease swimming and settle down. If a practical means of artificial planting could be introduced such as is now employed in Ceylon, the shores of the Philippine Islands could be lined with pearl.

The food fisheries of Bantayan are second in the Philippines, ranking next to those of Zamboanga. The value of the fishes disposed of to dealers (probably for export) during 1908 was 18,250 pesos (9,125 dollars United States currency). Boats come here from Cebu, Negros, and even Panay, to take cargoes of dried or pickled fish. At present there are 380 fish traps licensed by the municipality. In addition, large quantities of dried Holothurians (trepang, *Bêche de mér*) are prepared here, the export sales for last year amounting to 3,277 pesos and 11 centavos (1,638 dollars and 56 cents United States currency). This figure can be raised very considerably by increased industry on the part of the Bantayanos.

³ One practical measure would be the complete closing of this bed, or at least half of it, for three years, so that there will be enough mature oysters left to repopulate it, and "clutch," i. e., dead coral, rocks, old shells, etc., should be scattered over the bottom so that the young may have material to which they can attach. In this way the bed could be made much more productive than when first opened.

THE SUCCESSFUL TRANSFERENCE OF BLACK BASS TO
THE PHILIPPINE ISLANDS, WITH NOTES ON THE
TRANSPORTING OF LIVE FISH LONG
DISTANCES.

By ALVIN SEALE.

(From the Section of Fisheries, Biological Laboratory, Bureau of Science,
Manila, P. I.)

In April, 1907, I was authorized by the Insular Government to secure and bring to the Philippine Islands a shipment of live large-mouthed black bass [*Micropterus salmoides* (Lacépède)]. One hundred and seventy-five fingerlings, alive and in good condition, were secured at Folsom, California, upon the payment of a fee to the California State Fish Commission. Permission was secured from the United States Army Transport Service to ship the fish on the transport *Sherman*, and the success of this enterprise was due largely to the interest of both officers and men of that ship.

A small motor, driven by the electric current of the ship, was installed on the mess deck. An iron boiler, capacity 265 liters, was secured from the transport as an air reservoir, and a small air pump was connected with the boiler. A system of rubber pipes conducted the air from the boiler to the bottom of the cans in which the fish were carried and by working the motor only a short time sufficient air could be pumped into the reservoir to circulate through each can for four hours, the advantage of the reservoir being to maintain an even pressure and allow the air to cool. By means of a pipe, cold water could be kept running over the reservoir, which was also arranged so that ice could easily be packed around it.¹ The end of each of the rubber pipes leading

¹A system of cold-water coils inside the reservoir would perhaps be a better, but more expensive method.

into the cans was drawn to a very minute point so that the air simply bubbled up through the water in a very small stream. (See fig. 1.)

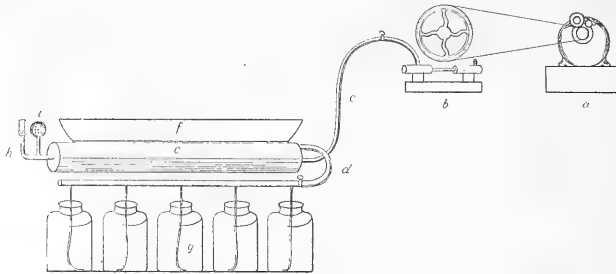

FIG. 1.—APPARATUS USED IN TRANSPORTING BLACK BASS TO THE PHILIPPINE ISLANDS.

When everything was ready, the fish were placed in six 38-liter milk cans which had previously been scalded and cleaned; about twenty-nine fish being allotted to each can. The temperature of the Spring Valley water in which the fish started was 11°; that of the air, 16°; and of the sea-water, 14°.

We sailed from San Francisco April 5, 1907. The next morning, while washing down decks, a sailor carelessly allowed some salt water to run into one can and fourteen of the fish therein were dead before we discovered the cause. However, not another fish was lost until we reached Honolulu. The second day out, food in the form of hard-boiled eggs, was offered the fish, but they would not eat. In the meantime the temperature of the water in the cans had been increased gradually to 21°, the air was 26°, and the sea water 25°.5.

When the transport coaled at Honolulu, despite all efforts to prevent it, more or less coal dust sifted into the cans; and six fish died during the two days' stay at that port. The remaining fish were alive when we reached Manila, May 4, twenty-eight days after starting from San Francisco.

When we were two days out from Honolulu the fish began to eat. They were fed on chopped crabs secured from the cold storage on the ship. They were given a small amount of food once a day, and they ate greedily. Shrimps were substituted occasionally for crabs.

A large pailful of water was taken from each can every day and replaced by one of fresh water from the ship's reservoir. On every third day each can, after the fish were poured into another, was thoroughly cleaned and scalded in order to prevent the growth of fungus; and every morning and evening the excreta and refuse in the bottom of the cans were siphoned out with a rubber pipe 18 millimeters in diameter. After leaving Honolulu the temperature of the water in

the cans was kept at about 21° until within two days of Manila, when it was increased gradually to 23°. When we arrived in Manila the temperature of the water in the cans was 23°, that of the air was 29°, and of the sea water 28°.

The fish had to be transported from Manila to Dagupan by rail, a distance of 193 kilometers, and thence 120 kilometers overland to Baguio, a mountain town in the Province of Benguet. This was the most difficult part of the trip, but it was accomplished in two days, with the loss of but one fish. The temperature of the water was lowered considerably during the last stages of the trip to Baguio, at which place the fish were planted in three distinct spots: One lot in the small lake near the Hotel Pines, another in a deep pool in the Trinidad River, and a third in the large Trinidad Lake. (See diagram, fig. No. 2.)

In December, 1909, I visited the places where these fish had been planted, and found that those placed in the small lake near the Hotel Pines had escaped early in the year; nothing was seen or heard of those planted in Trinidad River, but a tale was current of the capture of some large fish by the natives. The bass planted in Trinidad Lake had flourished and multiplied exceedingly well. A short trial with a fly gave sufficient proof that the lake was well stocked, as not only one of the original fish, but also one of the offspring was hooked; the latter (see Plate I) was 190 millimeters long and the parent fish was almost twice this length.

During February of the past year the small artificial lake in front of the Hotel Pines at Baguio was transformed into a good spawning pond by raising its walls, putting in concrete gates, and adding several loads of gravel for spawning beds. Twelve large bass caught in Trinidad Lake with a fly hook were transferred to this breeding pond on February 23. By May 4 they had spawned and there were hundreds of young bass in the pond, many of these have since been planted in other places, and some large bass were placed in Cayman Lake at Los Baños, Laguna Province. It is now an assured fact that people who live far inland may have this most desirable addition to their diet, and for those who care for it there is the pleasure and excitement of angling for this noble game fish.

TRANSFERRING MOSQUITO-EATING FISH.

In the year 1905 I was authorized by the Government of the Hawaiian Islands to secure and bring to Honolulu a shipment of live top minnows, *Fundulus heteroclitus* (Linn.), *Gambusia affinis* (B. & G.) and *Mallinnesia latipinna* La S. to assist in ridding that place of the pest of mosquitoes. These fishes belong to the family *Poeciliidae* and are found in the southern United States. They feed almost exclusively on the eggs and young of the mosquito. Fifteen hundred dollars United States currency was

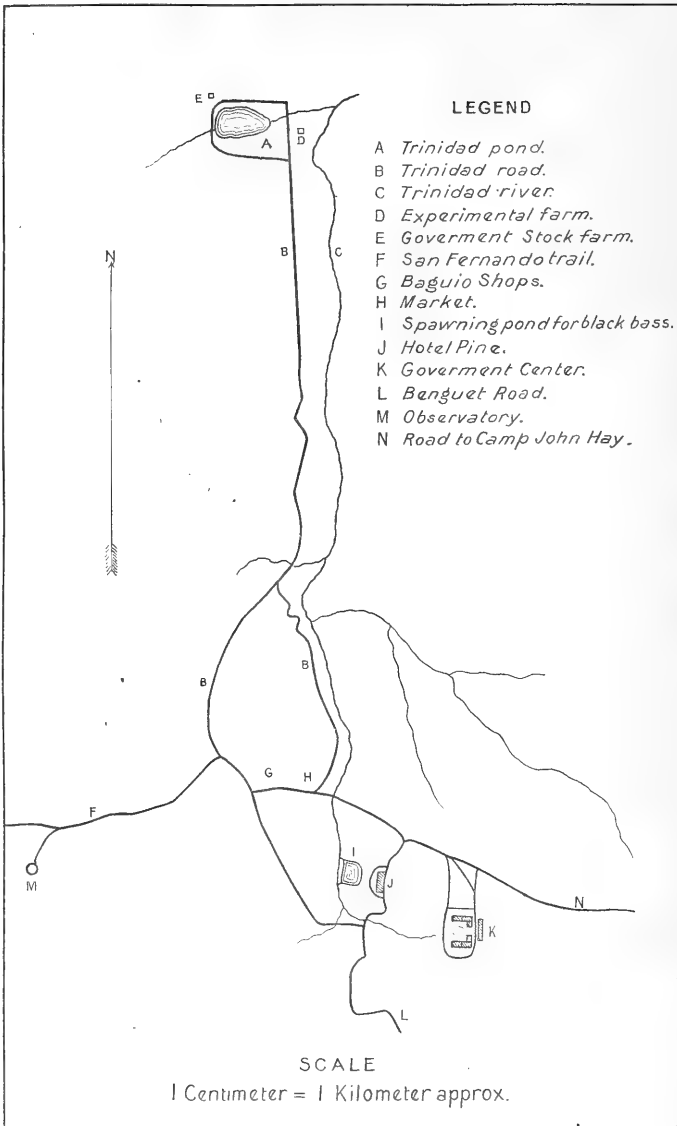

FIG. 2.—DIAGRAM OF BAGUIO AND VICINITY, SHOWING LOCATION OF BASS PONDS.

provided by the Territorial legislature for this venture. The fish were secured at Seabrook, Texas, and two weeks were spent in experimenting on conditions under which they could be transported through this long distance. It was proved that they could not successfully be iced and carried at a low temperature, a method which is usually most satisfactory, but that at a temperature of 23° they could be kept in ordinary milk cans with but little trouble.

On September 4, 1905, I left Seabrook, Texas, for Honolulu, with six 38-liter milk cans and 75 top minnows in each can. By adhering to the following routine, but little difficulty was experienced in the transportation of the fish. At 8 o'clock in the morning the fish were fed sparingly on prepared fish food, finely ground liver or hard-boiled eggs;² at 9.30 half the water in each can was siphoned from the bottom, thus cleaning out the can and removing all uneaten food and excrement, and an equal amount of fresh water was added. At noon, all the cans were aerated by means of a large bicycle pump, a sponge being tied over the hose to separate the air into fine particles. At 4 o'clock in the afternoon 8 liters of water were siphoned from the bottom of the cans and fresh water added; and late in the evening the cans were again aerated. At each place where the water was changed it was first tested by placing two fresh fish in a bucket containing the new water at the proper temperature.

Twelve fish died between Galveston, Texas, and San Francisco, California, and fifteen between San Francisco and Honolulu. I landed in Honolulu from the steamship *Alameda* on September 15, 1905, after a twelve days' trip from Texas. Only 27 of the 450 fish were lost. They were in good condition when they arrived and were at once transplanted to small breeding ponds which had already been prepared for them, and they at once began work on the mosquito larvæ. There was but 0.56° difference between the natural temperature of the water at Seabrook and that at Honolulu.

At the present time, these fish have multiplied to such an extent that there are now several hundred thousand of them and they have been distributed to all the large islands and have very perceptibly diminished the mosquito pest, as is evidence by the following statement quoted from a letter from the governor of Hawaii written on May 23, 1910:

* * * I am glad to state that top minnows have been a decided success here. They were introduced, I believe, about six years or so ago, and have been placed in all the different districts of this island and in a number of places on the other islands. They have multiplied rapidly and the streams and ponds about Honolulu are full of them. I understand that in some cases where ponds have swarmed with the larvæ of mosquitoes, the top minnows have entirely cleaned them out within a few days after their introduction. At Waimanalo, on this island, where mosquitoes were usually plentiful, there are now scarcely

² It would be better to feed every third day.

any, owing to the introduction of this fish. One difficulty has been experienced, and that is that the natives and Chinese catch them in considerable quantities to eat and for bait.

As a result of my experience in carrying live fish great distances, I have found that there are three important things which must not be lost sight of. *First, cleanliness.* All cans in which the fish are transported must be cleaned thoroughly at least every third day with hot water; this prevents the growth of fungus. The water in the cans must always be pure and the excrement and uneaten food must be siphoned out each day. The fish must never be touched with the hands. *Second, temperature.* Above all else a sudden change in the temperature of the water must be avoided; it must never be changed all at once, but the fresh water must gradually be mixed with that in which the fish already are. It should take at least several hours to lower the temperature one or even one-half degree. *Third, vigilance.* Success in this work is attained only at the cost of eternal vigilance. When the fish are suffering from any cause whatsoever, they come to the top of the can continually and only by constant care and watching can the proper remedy be learned.

ILLUSTRATIONS.

PLATE I.

Large-mounted black bass [*Micropterus salmoides* (Lacépède)] from Trinidad Lake, Baguio, Benguet.

TEXT FIGURES.

FIG. 1. Apparatus used in transporting black bass to the Philippine Islands.

- (a) Three-fourth horsepower electric motor.
- (b) Air pump.
- (c) Air supplying pipe to reservoir.
- (d) Air supplying pipe from reservoir.
- (e) 265-liter air reservoir (old iron hot-water boiler).
- (f) Box for holding ice.
- (g) 38-liter milk-can containing fish.
- (h) Safety valve.
- (i) Pressure indicator.

FIG. 2. Diagram of Baguio and vicinity, showing location of bass ponds.

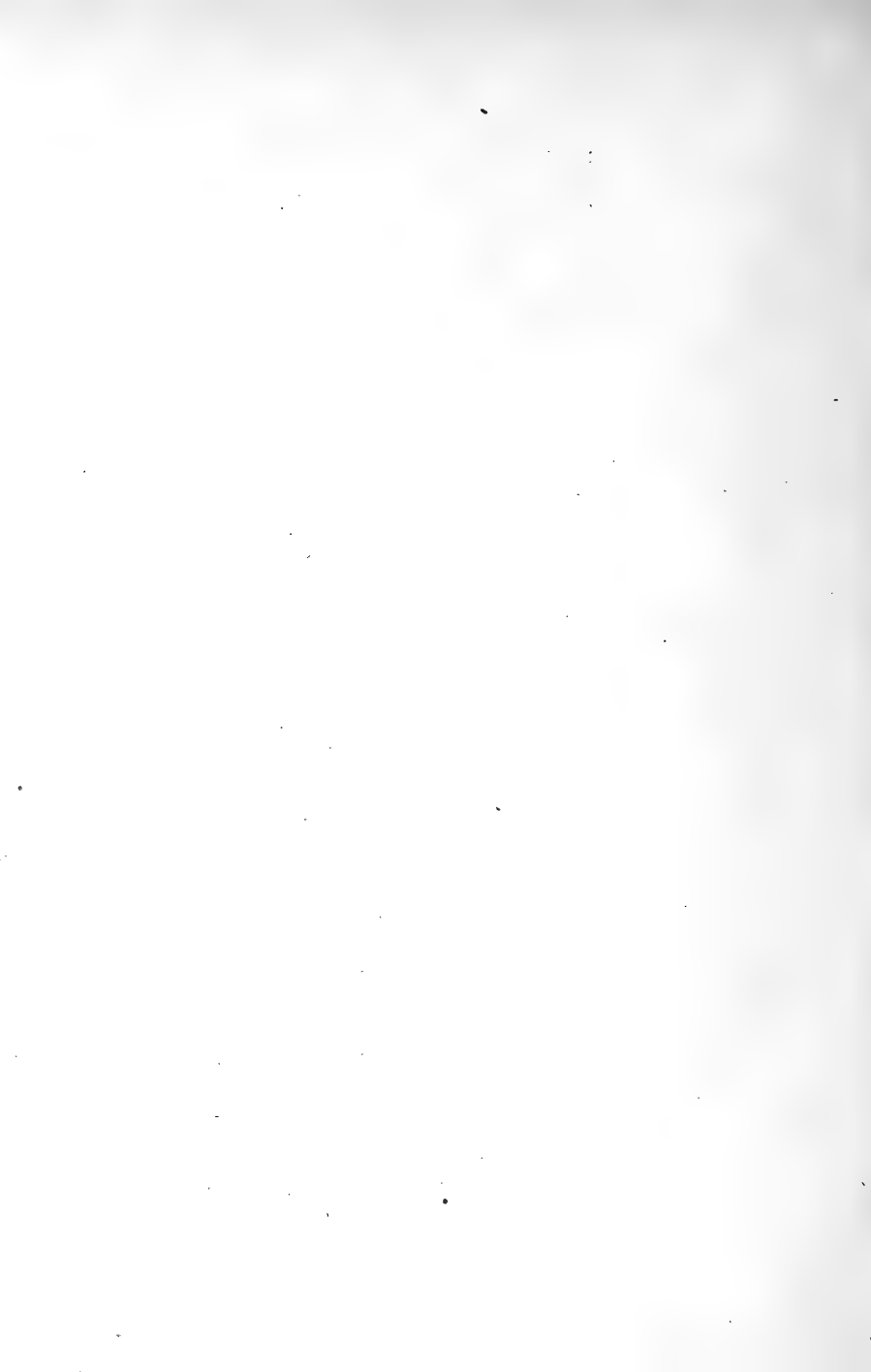

SCALE: TRANSPARENCE OF BLACK BASS.]

[PHIL. JOURN. SCI., VOL. V, NO. 3.

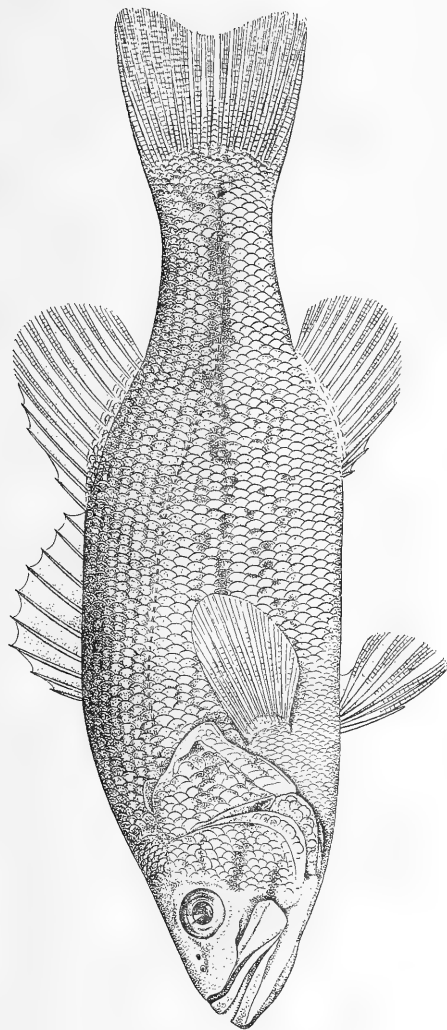

PLATE I.

W
31

CONTRIBUTIONS TO THE LEPIDOPTEROUS FAUNA OF
THE PHILIPPINES.

By W. SCHULTZE.

(From the Entomological Section, Biological Laboratory, Bureau of Science,
Manila, P. I.)

A. NEW LEPIDOPTERA.

Fam. LYCENIDÆ.

TARUCUS Moore.

Lep. Ceylon (1881), 1, 81.

Type: *T. theophrastus* Fabr.

Tarucus leopardus sp. nov. Pl. I, fig. 9.

♂. Upperside of wings iridescent purplish blue with a narrow dull black line along outer margin; cilia white. Tail black, tipped with white. Hind wing with two indistinct submarginal spots at posterior angle. Underside of wings white with a faint ochraceous tinge and numerous dark brown markings as follows: A narrow subcostal band from base to middle of fore wing, thence obliquely toward posterior outer angle; basal area with three triangular patches, the medial one being most prominent; outer area with three oblique bars from the costa, the second, which is the longest, reaching vein IV; a prominent, nearly round, postmedial spot between veins III and IV; a submarginal band and a marginal row of six very small spots, each between two veins and a very fine marginal line. Cilia white. Hind wing with a basal bar, six antemedial transverse streaks, two medial transverse streaks, two postmedial streaks, and a postmedial band from inner margin to vein VI; a prominent submarginal band, six submarginal spots and a fine anteciliary line. The submarginal area between veins I and III is dark ochraceous and the two black spots upon it are surrounded by a highly metallic, green line.

♀. Upperside of wings grayish brown with a bluish iridescence on basal half. Discal area whitish. All markings on underside similar to those above although less diffused. Hind wing with the submarginal row of spots large and distinct. Underside similar to that in ♂; all markings somewhat larger.

Length of wing: ♂, 11 millimeters; ♀, 13.5 millimeters.

Luzon, Province of Camarines, Paracale, P. I. (*J. P. Iddings* collector).

Type ♂, ♀ and cotype ♂ No. 12743 in Entomological Collection, Bureau of Science, Manila, P. I.

Fam. EUPTEROTIDÆ.

PSEUDOGANISA gen. nov.

Type: *P. currani*.

Palpi upturned and thickly fringed with hair. Fore wing broad, the apex rounded, outer margin produced at vein IV. Veins VII, VIII, IX, stalked. Outer margin of hind wing very much pronounced at vein IV and sharply angulate. Closely related to *Ganisa*.



Pseudoganisa currani sp. nov. *Pl. I, fig. 2.*

♂. Head ochraceous brown. General color of thorax, abdomen and wings tawny above; collar cream-white; basal half of the fore wing with shiny scales in certain lights. Fore wing with a dark brown spot at the end of cell and straight oblique postmedial line and two brownish submarginal patches between veins II and IV. Hind wing with the basal half hairy, the postmedial line slightly curved outward. Underside of thorax, abdomen and wings yellowish ochraceous. All markings as on upper side, with reddish suffusions, especially between postmedial line and margin.

♀ unknown.

Length of wing: ♂, 28 millimeters.

MINDANAO, Port Banga, District of Zamboanga, P. I. (*W. I. Hutchinson* collector).

Type ♂ No. 8748 in Entomological collection, Bureau of Science, Manila, P. I.)

I take pleasure in naming this species in honor of Mr. H. M. Curran, who has contributed a large number of insects to our collection.

Fam. LYMANTRIIDÆ.

NUMENES Walker.

Cat. Lep., Het., British Mus. (1855), 3, 662.

Type: *N. siletti* Walk.

Numenes insolita sp. nov. *Pl. I, fig. 4.*

♂. Head and thorax above dark brown, fore legs fuscous. Palpi, thorax below, middle and hind legs, as well as abdomen, yellow. Latter

with a dark brown spot on the second segment dorsally. Fore wing creamy white, with a dark brown band from the base, along inner margin, to posterior outer angle. A narrow oblique antemedial and a broad postmedial band from costa to inner margin. The postmedial band somewhat amplified beyond the cell. Hind wing yellow with an irregular, dark brown, marginal band. Underside of wings pale yellow. Fore wing with the postmedial band and hind wing with the marginal band as above.

♀ unknown.

Length of wing: ♂, 21 millimeters.

PALAWAN, Iwahig, P. I. (*W. Schultze* collector).

Type ♂ No. 10873 in Entomological Collection, Bureau of Science, Manila, P. I.

This species seems to be closely related to *N. contrahens* Walker, from Sarawak, Borneo, which has the fore wings testaceous.

ADULLIA Walker.

Cat. Lep., Het., British Mus. (1865), 33, 392.

Type: *A. lunifera* Walk.

Adullia benguetana sp. nov. *Pl. I, figs. 6, 7.*

♂. Head, thorax and abdomen ventrally, anal tuft and legs ochraceous. Thorax dorsally, and fore wing red-brown, the latter with the discal area of posterior margin irrorated with black scales. Abdomen dorsally and hind wing dark fuscous.

♀. Head, thorax above, and front and middle legs yellow, the latter somewhat paler; hind legs and thorax below fuscous. Abdomen dark brown, the anal tuft cream-white. Fore wing dark, fuscous brown; costal area, veins and cilia bright yellow. The interspaces between the veins irrorated with yellow scales, especially toward outer margin. Hind wing dark brown, the cilia fuscous brown.

Length of wing: ♂, 13.5 millimeters; ♀, 20 millimeters.

Found in *copulâ*: LUZON, Benguet, Baguio, P. I. (*J. P. Iddings* collector).

Types, ♂ and ♀, No. 12733 in Entomological Collection, Bureau of Science, Manila, P. I.

Adullia samarensis sp. nov. *Pl. I, fig. 1.*

♀. Head, antennæ and legs yellow, the latter irrorated with brown scales. Thorax above pale reddish brown with a few very long yellowish hairs. Thorax below and abdomen dark brown. Fore wing reddish brown; a large, lunular, cream-white, discal spot between veins III and V. A dentated row of yellow spots along outer margin and cilia. Posterior margins with a few very long, yellow hairs. Hind wing with the basal

half dark brown, the apical half yellow. Underside of wings similar to upper, though the discal spot of the fore wing is not as prominent.

♂ unknown.

Length of wing: ♀, 30 millimeters.

SAMAR, P. I. (*G. L. Parks* collector).

Cotypes, ♀ No. 12783 in Entomological Collection, Bureau of Science, Manila, P. I.

Fam. ARCTIIDÆ.

Subf. LITHOSIINÆ.

DEILEMERA Hübner.

Verz. bek. Schmetterl. (1818), 178.

Type: *D. evergista* Stoll.

DeilemERA gratia sp. nov. *Pl. I, fig. 3.*

♂. Head, collar and thorax cream-white. Palpi with a black spot on second and third joints laterally. A black spot on front and one on top of head, two on the collar, one on each tegula and three medially on the thorax. Legs white; coxæ and thorax below black-spotted. Abdomen pale yellow, with black segmental bands dorsally and two rows of lateral spots. Wings snow-white, semi-transparent. Fore wing with the veins more or less fuscous. Underside similar to upper, the fuscous color more pronounced especially along the costal margin of the fore wing.

♀. The black, abdominal band on the penultimate segment very wide and bi-emarginate posteriorly; anal segment cream-white.

Length of wing: ♂, 28.5 millimeters, ♀, 29 millimeters.

Luzon, Province of Benguet, Pauai, P. I., 2,250 meters (*R. C. McGregor* collector).

Types, ♂ and ♀, No. 11136 in Entomological Collection, Bureau of Science, Manila, P. I.

MONOTAXIS Hampson.

Cat. Lep., Phal., British Mus. (1900), 2, 181.

Type: *M. trimaculata* Hamps.

Monotaxis montanus sp. nov. *Pl. I, fig. 10.*

♀. Head, collar, tegulae, thorax and abdomen below ochraceous. Thorax and extremities of tegulae metallic blue-green. Abdomen fuscous. Fore wing ochraceous, the costal margin metallic blue-green except the apical third. A band from base along posterior margin expanding into a large patch below the cell and another wedge-shaped, postmedially. Hind wing pale ochraceous, the apical area fuscous.

♂ unknown.

Length of wing: ♀, 18 millimeters.

Luzon, Province of Benguet, Lutab, P. I., 1,000 meters (*R. C. McGregor* collector).

Type ♀ No. 12701 in Entomological Collection, Bureau of Science, Manila, P. I.

Fam. GEOMETRIDÆ.

Subf. LARENTIINÆ.

PHTHONOLOBA Warren.

Nov. Zool. (1894), 1, 397.

Type: *P. decussata* Moore.

Phthonoloba benguetana sp. nov. *Pl. I*, fig. 5.

♀. Head, collar and thorax bright green, a dark brown spot on each tegula. Abdomen and legs pale green, the latter streaked with brown and the former with a brown spot on the first segment. Fore wing bright green with a brown discocellular spot and double antemedial, medial, postmedial and submarginal brown zig-zag lines. The post-medial lines form a brown patch in the discal area and at the posterior margin. Hind wing pale green with a brown discocellular spot, a curved postmedial line and an internal fuscous marginal band. Cilia with a series of fuscous spots at the ends of the veins.

♂ unknown.

Length of wing: ♀, 19 millimeters.

Luzon, Province of Benguet, Pauai, P. I., 2,250 meters (*R. C. McGregor* collector).

Cotypes, ♀ No. 11177 in Entomological Collection, Bureau of Science, Manila, P. I.

Fam. TINEIDÆ.

Subf. GELECHIINÆ.

HYPERPERISSA Walsingham.

Cat. East. Lep., Het. (1900), 2, 546.

Type: *H. aurantiaca* Semper.

Hyperperissa pulchella sp. nov. *Pl. I*, fig. 8.

♀. Head, thorax, abdomen and legs dark, metallic blue. Wings golden yellow. Fore wing with a streak at the base and the apical third dark, metallic blue. Hind wing with the apical dark metallic blue, the inner margin of which is nearly straight.

♂ unknown.

Length of wing: ♀, 14 millimeters.

Luzon, Province of Benguet, Lutab, 1,000 meters, and Pauai, P. I., 2,250 meters (*R. C. McGregor* collector).

Type ♀ No. 12686 and paratype No. 11148 in Entomological Collection, Bureau of Science, Manila, P. I.

B. SPECIES OF LEPIDOPTERA HITHERTO UNRECORDED FROM THE PHILIPPINES.

Suborder RHOPHALOCERA.

Fam. LYCÆNIDÆ.

CHILADES Moore.

Lep. Ceyl. (1881), 1, 76.

Type: *C. laius* Cram.

CHILADES TROCHILUS Frey.

Lycæna trochilus Freyer, Neuere Beitr. Schmetterl. (1844), 5, 98, pl. 140, fig. 1.

Lycæna putli Kollar, Hügel's Kaschmir (1848), 4, pt. 2, 422.

Chilades putli Moore, *Lep. Ceyl.* (1881), 1, 77, pl. 35, fig. 4.

Chilades trochilus de Nicev., Butterfl. of India, Burma, and Ceylon (1890), 3, 91.

Zizera putli Semper,¹ Schmetterl. d. Phil. Ins. (1892), 5, 172, footnote.

LUZON, Mountain Province, Kalinga, Sabuc, P. I. (10561 *H. M. Curran*).

ZIZERA Moore.

Lep. Ceyl. (1881), 1, 78.

Type: *Z. alsus* Wien. Verz.

ZIZERA MORA Swinh.

Zizera mora Swinhoe, Proc. Zoöl. Soc., Lond. (1884) 506, pl. 47, fig. 2; de Nicev., Butterfl. of India, Burma and Ceylon (1890), 3, 118.

LUZON, Manila, P. I. (8019 *W. Schultze*).

ZIZERA GAIKA Trim.

Lycæna gaika Trimen, Trans. Ent. Soc. Lond., ser. 3 (1862), 1, 403.

Zizera gaika Butl., Proc. Zoöl. Soc. Lond. (1884), 484; de Nicev., Butterfl. of India, Burma and Ceylon (1890), 3, 118, pl. 26, fig. 174.

LUZON, Manila, P. I. (7351 *W. Schultze*); Laguna, Sta. Maria, P. I. (8532 *H. M. Curran*); Rizal, Montalban Gorge, P. I. (9128 *F. D. Nash*).

CASTALIUS Hübner.

Verz. bek. Schmetterl. (1816), 70.

Type: *C. rosimon* Fabr.

CASTALIUS ELNA Hewits.

Lycæna elna Hetwits., Ex. Butterfl. (1876), 5, *Lycæna* pl. 1, fig. 8.

Castalius elna Moore, Proc. Zoöl. Soc. Lond. (1877), 587; de Nicev., Butterfl. of India, Burma and Ceylon (1890), 3, 201; Bingham, Fauna British Ind., Butterfl., (1907), 2, 430.

PALAWAN, Iwahig, P. I. (11166 *W. Schultze*).

¹I quote this species again, as Semper mentions it as rather doubtful from the Philippines.

Fam. PAPILIONIDÆ.

Subf. PAPILIONINÆ.

PAPILIO Linnæus.

Syst. Nat. (1758), 1, 458.

Type: *P. priamus* Linn.

PAPILIO XUTHUS Linn.

Papilio xuthus Linn., *Syst. Nat.* (1767), 1, 751.

Papilio xanthus Rothsch., *Nov. Zool.* (1895), 2, 278.

Papilio xuthus Bingham, *Fauna British Ind., Butterfl.* (1907), 2, 38.

LUZON, Province of Benguet, Pauai, P. I., 2,250 meters (11130 *R. C. McGregor*).

PAPILIO NEPTUNUS Guér.

Papilio neptunus Guérin, *Deless. Souv. Inde* (1843), 2, 69; Wall., *Trans.*

Linn. Soc. (1865), 25, 42; Druce, *Proc. Zoöl. Soc. Lond.* (1873), 357;

Distant, *Rhop. Malay.* (1886), 335.

MINDANAO, P. I. (13196 *C. I. Overman*).

Fam. HESPERIDÆ.

PADUKA Distant.

Rhopal. Malay. (1886), 375.

Type: *P. glandulosa* Dist.

PADUKA GLANDULOSA Dist.

Paduka glandulosa Distant, *loc cit.* 376, *pl. 35, fig. 5.*

PALAWAN, Puerto Princesa, P. I. (8757 *C. M. Weber*).

Suborder HETEROCCERA.

Fam. SPHINGIDÆ.

Subf. PHILAMPELINÆ.

ANGONYX Boisduval.

Spec. Gen. Lep. Het. (1875), 1, 317.

Type: *A. testacea* Walk.

ANGONYX TESTACEA Walk.

Perigonia testacea Walk., *Cat. Lep., British Mus.* (1856), 8, 102.

Angonyx testacea Rothsch. and Jord., *Rev. Lep. Fam. Sphing.* (1903), 544.

LUZON, Manila, P. I. (11050 *R. Wern*).

Subf. SESSIINÆ.

CEPHONODES Hübner.

Verz. bek. Schmetterl. (1816), 131.

Type: *C. hylas* Linn.

CEPHONODES TITAN Rothsch.

Cephonodes titan Rothschild, *Nov. Zool.* (1899), 6, 69; Rothsch. and

Jord., *Rev. Lep. Fam. Sphing.* (1903), 469.

LUZON, Province of Benguet, P. I., 1,850 meters (12726 *J. P. Iddings*).

Fam. NOTODONTIDÆ.

GARGETTA Walker.

Cat. Lep. Ins., British Mus. (1864), 32, 455.

Type: *G. costigera* Walk.

GARGETTA COSTIGERA Walk.

Gargetta costigera Walk., *loc. cit.* 455; Hamps., Fauna British Ind. Moths (1892), 1, 135.

LUZON, Province of Cagayan, Tuguegarao, P. I. (9447 *W. Williamson*).

Fam. COSSIDÆ.

COSSUS Fabricius.

Ent. Syst. (1794), 3, pt. 2, 3.

Type: *C. ligniperda* Fabr.

COSSUS ACRONYCTOIDES Moore.

Brachylia acronyctoides Moore, *Proc. Zool. Soc. Lond.* (1879), 411, *pl.* 34, *fig.* 4.

Cossus acronyctoides Hamps., Fauna British Ind., Moths (1892), 1, 305.

LUZON, Province of Laguna, Los Baños, P. I. (12901 *E. M. Ledyard*).

Fam. LIMACODIDÆ.

NAGODA Moore.

Lep. Ceyl. (1887), 3, 542.

Type: *N. nigricans* Moore.

NAGODA NIGRICANS Moore.

Nagoda nigricans Moore, *loc. cit.*, 542, *pl.* 211, *fig.* 10; Hamps., *Ill. Typ.*

Lep. Het. British Mus. (1893), 9, *pl.* 161, *fig.* 1; Fauna British Ind., Moths (1892), 1, 401.

LUZON, Province of Benguet, Trinidad, P. I. (8352 *C. S. Banks*).

Fam. LASIOCAMPIDÆ.

ODONESTIS Germar.

Prod. (1811), 49.

Type: *O. potatoia* Fabr.

ODONOSTIS PLAGIFERA Walk.

Lebeda plagifera Walk., *Cat. Lep. Ins., British Mus.* (1855), 6, 1459;

Butl., Ill. Typ. Lep. Het., British Mus. (1881), 5, 73, *pl.* 99, *fig.* 5.

Odonestis plagifera Hamps., Fauna British Ind., Moths (1892), 1, 427.

LUZON, Province of Benguet, Baguio, P. I. (10494 *W. Schultze*).

Fam. LYMANTRIIDÆ.

AROA Walker.

Cat. Lep. Het., British Mus. (1855), 4, 791.

Type: *A. discalis* Walk.

AROA MAJOR Hamps.

Aroa major Hamps., Ill. Typ. Lep. Het. British Mus. (1893), 9, 74, pl. 159, fig. 3; Fauna British Ind., Moths (1892), 1, 437.

LUZON, Province of Benguet, Baguio, P. I. (10451 *W. Schultze*).

LÆLIA Stephens.

Syst. Cat. Brit. Ins. (1829), 2, 52.

Type: *L. cænosa* Hubn.

LÆLIA SUFFUSA Walk.

Ricine suffusa Walk., *Cat. Lep. Het.*, British Mus. (1855), 4, 824.

Prodoxa angulifera Walk., *loc. cit.*, 919.

Lælia suffusa Hamps., Fauna British Ind., Moths (1892), 1, 441.

LUZON, Manila, P. I. (3123, 5215, *W. Schultze*); NEGROS OCCIDENTAL, Bago, P. I. (6282 *C. S. Banks*).

DASYCHIRA Stephens.

Ill. Brit. Ent., Haust. (1829), 2, 58.

Type: *D. pudibunda* Linn.

DASYCHIRA HORSFIELDI Saund.

Arctia horsfieldii Saund., *Trans. Ent. Soc. Lond.* (1851), 1, 126, pl. 12, figs. 1, 2.

Dasychira horsfieldi Hamps., Fauna British Ind., Moths (1892), 1, 448.

PALAWAN, Iwahig, P. I. (10870 *W. Schultze*).

Fam. ARCTIIDÆ.

Subf. LITHOSIINÆ.

MANOBA Walker.

Journ. Linn. Soc., Zool. (1863), 7, 62.

Type: *M. implens* Walk.

* MANOBA FRACTILINEA Snell.²

Pitane fractilinea Snell., *Veth's Midd.-Sumatra Lep.* (1880), 38; Kirby, *Cat. Het.* (1892), 364.

Eugoa multipuncta Hamps., Ill. Lep. Het., British Mus. (1893), 9, 81, pl. 158, fig. 3.

Æmene multipuncta Hamps., Fauna British Ind., Moths (1894), 2, 93.

Stictane fractilinea Hamps., *Cat. Lep., Phal.* (1900), 2, 259.

LUZON, Manila, P. I. (4908 *C. S. Banks*).

²All species preceded by an * were determined by Sir George Hampson of the British Museum.

MILTOCHRISTA Hübner.

Verz. *bel. Schmetterl.* (1818), 166.

Type: *M. miniata* Forst.

MILTOCHRISTA SEMIFASCIA Walk.

Setina semifascia Walk., Cat. Lep. Ins. British Mus. (1854), 2, 521.

Lyclene scmfascia Moore, Lep. Ceylon (1882), 2, pl. 103, fig. 7.

Miltochrista semifascia Hamps., Fauna British Ind., Moths (1894), 2, 109.

LUZON, Province of Benguet, Baguio, P. I. (8818 *C. S. Banks*).

DARANTASIA Walker.

Journ. Linn. Soc. Lond. (1859), 3, 186.

Type: *D. cuneiplena* Walk.

DARANTASIA CUNEIPLENA Walk.

Darantasia cuneiplena Walk., *loc. cit.* Swinh., Cat. Het. Lep. (1892), 1, 99, pl. 3, fig. 17; Hamps., Cat. Lep., Phal. (1900), 2, 273.

NEGROS, Mount Canlaon, P. I. (12892 *C. S. Banks*).

Subf. NOLINÆ.

CELAMA Walker.

Cat. British Mus. (1864), 32, 500.

Type: *C. bifascialis* Walk.

CELAMA TANIATA Snell.

Nola taniata Snell., Tijdschr. v. Ent. (1874), 17, 65, pl. 6, fig. 1; Kirby, Cat. Het. (1892), 372.

Roesella fragilis Swinh., Trans. Ent. Soc. Lond. (1890), 184; Hamps., Fauna British Ind., Moths (1894), 2, 139; Kirby, *loc. cit.* 376.

Sorocostia mesozana Lucas, Proc. Linn. Soc. N. S. W. (1890), 4, 1075; Kirby, *loc. cit.* 377.

Celama taniata Hamps., Cat. Lep., Phal. (1900), 2, 17.

LUZON, Manila, P. I. (2377, 3978, 5148, *C. S. Banks*).

Subf. NYCTEOLINÆ.

EARIAS Hübner.

Verz. (1818), 395.

Type: *E. clorana* Linn.

*EARIAS INSULANA Boisd.

Tortrix insulana Boisd., Faune Ent. Madag. (1833), 121, pl. 16, fig. 9.

Earias insulana Rogenh., Verh. Zoöl. Bot. Ges. Wien. (1870), 20, 869.

Earias smardinana Zell., Lep. Mic. Wahlb. Caffr. (1852), 79.

Earias frondosana Walk., Cat. Lep. British Mus. (1863), 27, 204.

Earias similima Walk., *op. cit.* (1866), 35, 1775.

Earias siliquana Stainton, Trans. Ent. Soc. Lond. (1865), ser. 3, 5, 89.

Earias gossypii Frauentf., Verh. Zoöl. Bot. Ges. Wien. (1867), 17, 791.

Earias tristrigosa Butl., Proc. Zoöl. Soc. Lond. (1881), 614; *op. cit.* (1883), 157.

Earias insulana Swinh., Cat. Lep. Het. (1892), 1, 133; Hamps., Fauna British Ind., Moths (1894), 2, 133.

LUZON, Manila, P. I. (2936 *C. S. Banks*).

Fam. NOCTUIDÆ.

Subf. TRIFINÆ.

AGROTIS Ochsenheimer.

Eur. Schmetterl. (1816), 4, 66.

Type: *A. segetis* Schiff.

AGROTIS SEGETIS Schiff.

Noctua segetum Schiff., Wien. Verz. (1876), 252.

Agrotis segetum Leech, Proc. Zool. Soc. Lond. (1889), 499; Meyr., Handb. British Lep. (1895), 91.

Agrotis segetis Hamps., Fauna British Ind., Moths (1894), 2, 181.

LUZON, Province of Benguet, Pauai, P. I., 2,250 meters (11385 *R. C. McGregor*).

AGROTIS BICONICA Koll.

Agrotis biconica Koll., Hügel's Kaschmir. (1844), 4, 480.

Agrotis exigua Koll., *loc. cit.* 481.

Agrotis spiculifera Guen., Noct., (1852), 1, 266.

Agrotis aristifera Guen., *op. cit.*; Moore, Lep. Ceylon (1884), 3, 32, pl. 147, fig. 5.

Agrotis biconica Hamps., Fauna British Ind., Moths (1894), 2, 182.

LUZON, Province of Benguet, Pauai, P. I., 2,250 meters (11377 *R. C. McGregor*).

AGROTIS C-NIGRUM Linn.

Phalæna-Noctua c-nigrum Linn., Syst. Nat. (1758), 852.

Noctua c-nigrum Schiff., Wien. Verz. (1776), 77.

Graphiphora c-nigrum Steph., Ill. British Ent. Haust. (1829), 2, 136.

Agrotis c-nigrum Hamps., Fauna British Ind., Moths (1894), 2, 188.

LUZON, Province of Benguet, Pauai, P. I., 2,250 meters (11380 *R. C. McGregor*).

AGROTIS YPSILON Rott.

Noctua ypsilon Rott., Naturf. (1776), 11, 141.

Bombyx spinula Esp., Schmetterl. Eur. (1782), 3, pl. 63, fig. 6, 7.

Noctua suffusa Fabr., Mant., Ins. (1787), 2, 157.

Agrotis suffusa Treit., Schmetterl. Eur. (1825), 5, 152.

Agrotis ypsilon Hamps., Fauna British Ind., Moths (1894), 2, 182.

LUZON, Manila, P. I. (9748 *W. Schultze*).

AGROTIS INGRATA Butl.

Agrotis ingrata Butl., Ann. Mag. Nat. Hist. (1878), V, 1, 162; Ill. Typ.

Lep. Het., British Mus. (1878), 2, 27, fig. 9.

LUZON, Province of Benguet, Pauai, P. I., 2,250 meters (11185, 11384, *R. C. McGregor*).

ACRONYCTA Ochsenheimer.

Eur. Schmetterl. (1816), 4, 62.

Type: *A. leporina* Linn.

ACRONYCTA SINENS Walk.

Orthosia sinens Walk., Cat. Lep. Ins., British Mus. (1857), 11, 746.

Acronycta sinens Hamps., Fauna British Ind., Moths (1894), 2, 241.

LUZON, Manila, P. I. (9645); Benguet, Baguio, P. I. (10462 W. *Schultze*).

CURGIA Walker.

Journ. Linn. Soc. Lond. (1864), 7, 166.

Type: *C. nonagrica* Walk.

CURGIA NONAGRICA Walk.

Curgia nonagrica Walk., *loc. cit.*

Radinacra euthusa Hamps., Ill. Typ. Lep. Het., British Mus. (1891), 8, 79, pl. 145, fig. 1.

LUZON, Manila, P. I. (3821, 7880 W. *Schultze*); Tarlac, Anao, P. I. (9455 R. C. *McGregor*).

LEUCANIA Oechsenheimer.

Eur. Schmetterl. (1816), 4, 81.

Type: *L. comma* Linn.

LEUCANIA INFRAMICANS Hamps.

Leucania inframicans Hamps., Ill. Typ. Lep. British Mus. (1893), 9, 90, pl. 161, fig. 2; Fauna British Ind., Moths (1894), 2, 270.

MINDANAO, Camp Keithley, P. I. (7392 Mrs. M. S. *Clemens*); LUZON, Manila, P. I. (9680 R. *Werm*).

LEUCANIA NIGRILINEA Leech.

Leucania nigrilinea Leech, Proc. Zool. Soc. Lond. (1899), 483, pl. 50, fig. 8.

LUZON, Province of Benguet, Lutab, P. I., 2,250 meters (12709 R. C. *McGregor*).

PHYCIDOPSIS Hampson.

Ill. Typ. Lep. Het., British Mus. (1893), 9, 91.

Type: *P. albovittata* Hamps.

PHYCIDOPSIS ALBOVITTATA Hamps.

Phycidopsis albovittata Hamps., *loc. cit.*, pl. 161, fig. 13; Fauna British Ind., Moths (1894), 2, 288.

LUZON, Province of Benguet, Lutab, P. I. (12699 R. C. *McGregor*).

Subf. **ACONTIINÆ**.

EUBLEMMA Hübner.

Verz. (1816) 256.

Type: *E. respersa* Hübn.

* **EUBLEMMA VERSICOLOR** Walk.

Autoba versicolor Walk., *Journ. Linn. Soc. Lond.* (1864), 7, 58.

Mestleta angulifera Moore, Desc. Ind. Lep. Ins. Coll. Atk. (1879), 179; Lep. Ceylon (1885), 3, 208, pl. 175, figs. 2, 2a.

Eublemma angulifera Hamps., Fauna British Ind., Moths (1894), 2, 343. *Eublemma versicolor* Swinh., Cat. Lep., Het. (1900), 2, 65.

LUZON, Manila, P. I. (2938 W. *Schultze*).

Subf. SARROTHRIPINÆ.

BLENINA Walker.

Cat. Lep. Het., British Mus. (1857), 13, 1214. •

Type: *B. donans* Walk.

BLENINA DONANS Walk.

Blenina donans Walk., *loc. cit.*, 1215; Moore, *Lep. Ceylon* (1885), 3, 129, pl. 160, fig. 2; Hamps., *Fauna British Ind., Moths* (1894), 2, 377.

LUZON, Manila, P. I. (9689 *R. Werm.*).

BLENINA QUINARIA Moore.

Blenina quinaria Moore, *Descr. Ind. Lep. Ins. Coll. Atk.* (1879), 158, pl. 5, fig. 5; Hamps., *Fauna British Ind., Moths* (1894), 2, 379.

LUZON, Manila, P. I. (9191 *M. Garcia.*).

CLETTHARRA Walker.

Cat. Lep. Ins. British Mus. (1863), 27, 101.

Type: *C. valida* Walk.

CLETTHARRA ALBONOTATA Hamps.

Cletharra albonotata Hamps., *Fauna British Ind., Moths* (1894), 2, 384.

LUZON, Manila, P. I. (6388 *W. Schultze.*).

Subf. STICTOPTERINÆ.

MACEDA Walker.

Cat. Lep. Het. British Mus. (1857), 13, 1140.

Type: *M. mansueta* Walk.

MACEDA MANSUETA Walk.

Maceda mansueta Walk., *loc. cit.* 1141.

Calduba obdenta Walk., *op. cit.* (1858), 15, 1815.

Maceda discalis Walk., *Journ. Linn. Soc. Lond.* (1864), 7, 176.

Maceda mansueta Moore, *Lep. Ceylon* (1884), 3, 82, pl. 154, fig. 4, 5; Hamps., *Fauna British Ind., Moths* (1894), 2, 397.

LUZON, Manila, P. I. (9229 *R. Parás.*).

GYRTONA Walker.

Cat. Lep. Het., British Mus. (1863), 27, 89.

Type: *G. proximalis* Walk.

GYRTONA LAPIDARIA Walk.

Gyrtona lapidaria Walk., *op. cit.* (1864), 31, 257; Hamps., *Ill. Lep. Het. British Mus.* (1889), 7, pl. 143, fig. 20; *Fauna British Ind., Moths* (1894), 2, 406.

LUZON, Bataan, Lamao, P. I. (6961 *H. Cuzner.*).

GYRTONA HYLUSALIS Walk.

Gyrtona hylusalis Walk., *Cat. Lep. Ins. British Mus.* (1863), 27, 93; Hamps., *Ill. Het. British Mus.* (1893), 9, pl. 163, fig. 18; *Fauna British Ind., Moths* (1894), 2, 405.

LUZON, Province of Benguet, Baguio, P. I. (10458 *W. Schultze.*).

Subf. QUADRIFINÆ.

SYPNA Guenée.

Noct. (1852), 3, 144.

Type: *S. smicronigera* Guen.

SYPNA PUNCTOSA Walk.

Tavia punctosa Walk., Cat. Lep. Ins. British Mus. (1865), 33, 939.

Sypna ochreicilia Hamps., Ill. Het. British Mus. (1891), 8, 89, pl. 147, fig. 1.

Sypna punctosa Hamps., Fauna British Ind., Moths (1894), 2, 447.

LUZON, Province of Benguet, Pauai, P. I., 2,250 meters (11138 R. C. McGregor).

ERCHEIA Walker.

Cat. Lep. Het. British Mus. (1857), 13, 1107.

Type: *E. cyllaria* Cram.

ERCHEIA CYLLOTA Guen.

Achaea cyllota Guen., Noct. (1852), 3, 248.

Ercheia cyllota Moore, Lep. Ceylon (1885), 3, 115, pl. 157, fig. 2.

LUZON, Manila, P. I. (2585 W. Schultze).

NYCTIPAO Hübner.

Verz. (1818), 271.

Type: *N. crepuscularis* Linn.

NYCTIPAO STRINGIPENNIS Moore.

Nyctipao stringipennis Moore, Proc. Zool. Soc. Lond. (1883), 25; Hamps.,

Fauna British Ind., Moths (1894), 2, 460.

LUZON, Manila, P. I. (5086 C. S. Banks).

CHRYSOPERA Hampson.

Fauna British Ind., Moths (1894), 2, 493.

Type: *C. combinans* Walk.

CHRYSOPERA COMBINANS Walk.

Achaea combinans Walk., Cat. Lep. Het. British Mus. (1858), 14, 1399;

Moore, Lep. Ceylon (1885), 3, 165, pl. 169, fig. 3.

Chrysopera combinans Hamps., loc. cit. 493.

LUZON, Province of Tarlac, Anao, P. I. (9449 R. C. McGregor).

HYPÆTRA Guenée.

Noct. (1852), 3, 259.

Type: *H. noctuoides* Guen.

HYPÆTRA NOCTUOIDES Guen.

Hypætra noctuoides Guen., loc. cit.; Hamps., Fauna British Ind., Moths (1894), 2, 507.

LUZON, Manila, P. I. (4761 E. D. Merrill).

HYPÆTRA BUBO Hübn.

Athyra bubo Hübn., Zutr. (1832), 4, 13, figs. 633, 634.

Hypætra bubo Hamps., Fauna British Ind., Moths (1894), 2, 508.

LUZON, Manila, P. I. (1432 W. Schultze).

DORDURA Moore.

Descr. Ind. Lep. Ins. Coll. Atk. (1879), 170.

Type: *D. aliena* Walk.

DORDURA ALIENA Walk.

Hypætra aliena Walk., *Cat. Lep. British Mus.* (1865), 33, 964.

Dysgonia tincta Hamps., *Ill. Typ. Het. British Mus.* (1893), 9, 112,
pl. 165, fig. 3.

Dordura aliena Hamps., *Fauna British Ind., Moths* (1894), 2, 511.

LUZON, Manila, P. I. (8798 *J. Guerrero*).

HAMODES Guenée.

Noct. (1852), 3, 202.

Type: *H. propitia* Guen.

HAMODES AURANTIACA Guen.

Hamodes aurantiaca Guen., *loc. cit.* 203.

Ophisma atticicola Walk., *Cat. Lep. Het. British Mus.* (1858), 14, 1383.

Hamodes atticicola Swinh., *Proc. Zoöl. Soc. Lond.* (1885), 463.

Hypernaria dicistriga Moore, *Proc. Zoöl. Soc. Lond.* (1867), 78.

Hamodes dicistriga Moore, *op. cit.* (1877), 609.

Hamodes marginata Moore, *Descr. Ind. Lep. Ins. Coll. Atk.* (1882), 169.

Hamodes aurantiaca Hamps., *Fauna British Ind., Moths* (1894), 2, 547.

LUZON, Manila, P. I. (12683 *C. S. Banks*).

ENMONODIA Walker.

Cat. Lep. Het. British Mus. (1858), 14, 1332.

Type: *E. pudens* Walk.

ENMONODIA PUDENS Walk.

Hypopyra pudens Walk., *loc. cit.* 1329.

Spirama pudens Hamps., *Fauna British Ind., Moths* (1894), 2, 555.

Enmonodia pudens Butl., *Entom.* (1893), 26, 353.

Enmonodia hypopyroides Walk., *loc. cit.*, 1333.

Hypopyra grandæva Feld., *Reise Nov., Lep.* (1873), pl. 115, fig. 2.

Hypopyra persimilis Moore, *Proc. Zoöl. Soc. Lond.* (1877), 608.

LUZON, Province of Laguna, Los Baños, P. I. (12902 *E. M. Ledyard*).

Fam. EPIPLEMIDÆ.

ORUDIZA Walker.

Cat. Lep. Ins. British Mus. (1861), 23, 857.

Type: *O. protheclaria* Walk.

ORUDIZA PROTHECLARIA Walk.

Orudiza protheclaria Walk., *loc. cit.* 858; Hamps., *Fauna British Ind., Moths* (1895), 3, 124.

LUZON, Province of Bataan, Lamao, P. I. (9149 *W. Schultze*).

Fam. GEOMETRIDÆ.

Subf. BOARMIINÆ.

ORZONOBA Walker.

Cat. Lep. Het. British Mus. (1860), 20, 218.

Type: *O. clelia* Cram.

ORZONOBA CLELIA Cram.

Phalæna clelia Cram., *Pap. Exot.* (1782), 3, 172, *pl. 288, figs. B, C.*

Orzonoba clelia Moore, *Lep. Ceylon* (1887), 3, 395, *pl. 187, fig. 2; Hamps.,*

Fauna British Ind., Moths (1895), 3, 212.

LUZON, Manila, P. I. (7138 W. *Schultze*).

APLOCHLORA Warren.

Proc. Zool. Soc. Lond. (1893), 386.

Type: *A. vivilaca* Walk.

APLOCHLORA VIRIDIS Warren.

Aplochloa viridis Warren, *loc. cit., pl. 31, fig. 7.*

LUZON, Province of Benguet, Pauai, P. I., 2,250 meters (1137? *R. C. McGregor*).

Subf. LARENTIINÆ.

PHOTOSCOTOSIA Warren.

Proc. Zool. Soc. Lond. (1888), 328.

Type: *P. miniosata* Walk.

PHOTOSCOTOSIA MINIOSATA Walk.

Scotosia miniosata Walk., *Cat. Lep. Het. British Mus.* (1862), 25, 1354.

Photoscotosia miniosata Hamps., *Fauna British Ind., Moths* (1895), 3, 380.

LUZON, Province of Benguet, Panai, P. I., 2,250 meters (11134 *R. C. McGregor*).

CATACLYSME Hübner.

Verz. bek. Schmetterl. (1818), 329.

Type: *C. riguata* Hübn.

CATACLYSME CONTURBATA Walk.

Larentia conturbata Walk., *Cat. Lep. Ins. British Mus.* (1862), 26, 1703.

Cataclysmo conturbata Hamps., *Fauna British Ind., Moths* (1895), 3, 349.

LUZON, Province of Benguet, Pauai, P. I., 2,250 meters (11379 *R. C. McGregor*).

PHTHONOLOBA Warren.

Nov. Zool. (1894), 1, 397.

Type: *P. decussata* Moore.

PHTHONOLOBA DECUSSATA Moore.

Phthonoloba decussata Moore, *Proc. Zool. Soc. Lond.* (1867), 655, *pl. 33, fig. 10.*

NEGROŚ, Mount Canlaon, 850 meters (6448 *C. S. Banks*).

Subf. ACIDALIINÆ.

ACIDALIA Treitschke.

Eur. Schmetterl. (1825), 5, 438.Type: *A. ochrata* Scop.

*ACIDALIA RUFULA Swinh.

Acidalia rufula Swinh.

LUZON, Manila, P. I. (3506 C. S. Banks).

Subf. GEOMETRINÆ.

DYSPHANIA Hübner.

Verz. (1816), 175.Type: *D. militaris* Linn.

DYSPHANIA PALMYRA Stoll.

Phalæna Bombyx palmyra Stoll, *Cram. Pap. Exot.* (1790), 5, 159, pl. 36, fig. 1.*Eüschema palmyra* Hübn., *Verz.*, (1816), 175; *Hamps., Fauna British Ind., Moths* (1895), 3, 470.*Eüschema transversa* Moore, *Lep. Ceylon* (1887), 3, 422, pl. 189, figs. 3, 3a.*Dysphania palmyra* Swinh., *Cat. Lep. Het.* (1900), 2, 381.

PALAWAN, Iwahig, P. I. (9445 C. M. Weber, 11106 W. Schultze).

AFRENA Hampson.

Trans. Ent. Soc. Lond. (1895), 314.Type: *A. esmeralda* Hamps.

*AFRENA ESMERALDA Hamps.

Afrena esmeralda Hamps., *Trans. Ent. Soc. Lond.* (1895), 314; *Fauna British Ind., Moths* (1896), 4, 565.

LUZON, Manila, P. I. (11545 W. Schultze).

Fam. PYRALIDÆ.

Subf. ANERASTIINÆ.

ANERASTIA Hübner.

Verz. (1816), 367.Type: *A. lotella* Hübn.

*ANERASTIA CELSELLA Walk.

Anerastia celsella Walk., *Cat. Lep. British Mus.* (1863), 27, 193; *Hamps., Fauna British Ind., Moths* (1896), 4, 56.

LUZON, Manila, P. I. (3831 C. S. Banks).

*ANERASTIA PALLIDICOSTA Walk.

Pempelia cautella Walk., *Cat. Lep. British Mus.* (1863), 27, 73.*Cadra defectella* Walk., *op. cit.* (1864), 30, 962.*Ephestia cautella* Hamps., *Fauna British Ind., Moths* (1896), 4, 66.

LUZON, Manila, P. I. (117, 3828, 3876 C. S. Banks).

NEPHOPTERYX Hübner.

Verz. (1816), 370.

Type: *N. rhenella* Zinck.

* NEPHOPTERYX SYNTARACTIS Turn.

Nephoptyx syntaractis Turner, Proc. Roy. Soc. Queensl. (1904), 18, 145.

LUZON, Manila, P. I. (4169 *C. S. Banks*).

CANTHELEA Walker.

Cat. Lep. British Mus. (1866), 35, 1726.

Type: *C. ægnusalis* Walk.

* CANTHELEA ÆGNUSALIS Walk.

Pyralis?ægnusalis Walk., *op. cit.* (1859), 19, 905.

Homacrosoma gratella Walk., *op. cit.* (1863), 27, 26.

Homacrosoma derasella Swinh., Proc. Zool. Soc. Lond. (1885), 877, pl. 57, fig. 19.

Epicrocis ægnusalis Hamps., Fauna British Ind., Moths (1896), 4, 85.

LUZON, Manila, P. I. (2376, 2632 *C. S. Banks*).

PHYCITA Curtis.

British Ent. (1840), 6, 233.

Type: *P. spissicella* Fabr.

* PHYCITA PROXIMALIS Walk.

Nephoptyx proximalis Walk., *Cat. Lep. British Mus.* (1863), 27, 68.

Phycita proximalis Hamps., Fauna British Ind., Moths (1896), 4, 94.

LUZON, Manila, P. I. (5864 *C. S. Banks*).

* PHYCITA CLIENTELLA Zell.

Nephoptyx clientella Zell., *Stett. Ent. Zeit.* (1867), 396.

Phycita clientella Hamps., Fauna British Ind., Moths (1896), 4, 94.

LUZON, Manila, P. I. (2628 *C. S. Banks*; 5246 *W. Schultze*).

RHODOPHÆA Guenée.

Eur. Microl. Ind. Meth. (1845), 74.

Type: *R. advenella* Zinck.

* RHODOPHÆA HERINGII Rag.

Rhodophæa heringii Rag., *Ann. Soc. Ent. France* (1888), 282; Hamps.,

Fauna British Ind., Moths (1896), 4, 99.

LUZON, Manila, P. I. (2631 *C. S. Banks*).

Subf. ENDOTRICHINÆ.

ENDOTRICHIA Zeller.

Iris (1847), 293.

Type: *E. flammealis* Schiff.

* ENDOTRICHIA PUNCTICOSTALIS Walk.

Rhisina puncticostalis Walk., *Cat. Lep. British Mus.* (1865), 34, 1324.

LUZON, Manila, P. I. (4176 *C. S. Banks*; 4244 *Geo. L. Aranceta*).

Subf. PYRALINÆ.

PYRALIS Linnæus.

Syst. Nat. (1767), 12, 881.Type: *P. farinalis* Linn.

*PYRALIS PICTALIS Curt.

Asopia pictalis Curt., *British Ent.* (1834), 11, pl. 527.*Pyralis pronæalis* Walk., *Trans. Ent. Soc. Lond.* (1859), 19, 906.*Pyralis proximalis* Walk., *Trans. Ent. Soc. Lond.* (1864), 120.*Myclois bractiatella* Walk., *Cat. Lep. British Mus.* (1863), 27, 36;
Moore, *Lep. Ceyl.* (1887), 3, 262, *pl. 178, fig. 3.*LUZON, Manila, P. I. (2592 *C. S. Banks*).

Subf. HYDROCAMPINÆ.

NYMPHULA Schrank.

Fauna Boica (1802), 2, 162.Type: *N. nymphaea* Linn.

*NYMPHULA TURBATA Butl.

Nymphula turbata Butl., *Trans. Ent. Soc. Lond.* (1881), 586; *Hamps.*,*Fauna British Ind., Moths* (1896), 4, 192.LUZON, Manila, P. I. (2934 *W. Schultze*, 4172 *C. S. Banks*, 5898
G. M. Nell).

MUSOTIMA Meyrick.

Trans. Ent. Soc. Lond. (1884), 288.Type: *M. anducalis* Feld.

*MUSOTIMA SUFFUSALIS Hamps.

Musotima suffusalis Hamps., *Ill. Lep. Het. British Mus.* (1893), 9, 178.
pl. 174, fig. 20; *Fauna British Ind., Moths* (1896), 4, 199.LUZON, Manila, P. I. (5884 *G. M. Nell*).

ORPHNOPHANES Lederer.

Wien. Ent. Mon. (1863), 428.Type: *O. eucerasalis* Walk.

*ORPHNOPHANES ALBISIGNALIS Hamps.

Orphnophanes albisignalis Hamps., *Fauna British Ins., Moths* (1896),
4, 231.LUZON, Province of Benguet, Trinidad, P. I. (8688 *C. S. Banks*).

Subf. MARGARONIINÆ.

LOMOTROPA Lederer.

Wien. Ent. Mon. (1863), 7, 404.Type: *L. costiflexalis* Guen.

LOMOTROPA COSTIFLEXALIS Guen.

Pygospila costiflexalis Guen., *Delt. et Pyral.* (1854), 313; *Hamps.*,*Fauna British Ind., Moths* (1896), 4, 362.*Lomotropa costiflexalis* Led., l. c. 405, *pl. 14, fig. 8.*LUZON, Manila, P. I. (3549 *R. E. Brown*, *S. J.*).

Subf. PYRAUSTINÆ.

OMPHISA Moore.

Lep. Ceylon (1886), 3, 317.

Type: *O. anastomosalis* Guen.

OMPHISA ANASTOMOSALIS Guen.

Pionea anastomosalis Guen., Delt. et Pyral. (1854), 373.

Omphisa anastomosalis Hamps., Fauna British Ind., Moths (1896), 4, 382; Swinh., Cat. Lep., Het. (1900), 2, 521.

LUZON, Manila, P. I. (8049 *C. S. Banks*).

CHROCHIPHORA Hübner.

Geyer, Samml., Exot. Schmetterl. (1838), 4, 12.

Type: *C. testulalis* Hubn.

CHROCHIPHORA TESTULALIS Hubn.

Chrochipora testulalis Hubn., *loc. cit.*, figs. 629, 630.

Stenia testulalis Guen., Delt. et Pyral. (1854), 230.

Siriocauta testulalis Led., Wien. Ent. Mon. (1863), 7, 424.

Maruca testulalis Moore, *Lep. Ceylon* (1885), 3, 298; Hamps., Fauna British Ind., Moths (1896), 4, 393.

LUZON, Manila, P. I. (9757 *R. Werm*).

ACHARANA Moore.

Lep. Ceylon (1885), 3, 285.

Type: *A. phœopteris* Guen.

ACHARANA LICARSISALIS Walk.

Botys licarsisalis Walk., Cat. Lep. Het., British Mus. (1859), 18, 686.

Pachyzancla licarsisalis Hamps., Fauna British Ind., Moths (1896), 4, 402.

Acharana licarsisalis Swinh., Cat. Lep., Het. (1900), 2, 526.

LUZON, Manila, P. I. (3124, 3926, 4323, 4727, *W. Schultze*).

Fam. TINEIDÆ.

MICROCOSSUS Moore.

Lep. Ceylon (1885), 3, 497.

Type: *M. mackwoodii* Moore.

MICROCOSSUS MACKWOODII Moore.

Microcossus mackwoodii Moore, *loc. cit.*, 498, pl. 208, fig. 9.

LUZON, Manila, P. I. (4757, 8047 *W. Schultze*).

ILLUSTRATIONS.

PLATE I.

- FIG. 1. *Adlullia samarensis* Schultze ♀.
2. *Pseudoganisa currani* Schultze ♂.
3. *Deilemera gratia* Schultze ♀.
4. *Numenes insolita* Schultze ♂.
5. *Phthonoloba benguetana* Schultze ♀.
6. *Adlullia benguetana* Schultze ♂.
7. *Adlullia benguetana* Schultze ♀.
8. *Hyperperissa pulchella* Schultze ♀.
9. *Tarucus leopardus* Schultze ♂ (underside):
10. *Monotaxis montanus* Schultze ♀.



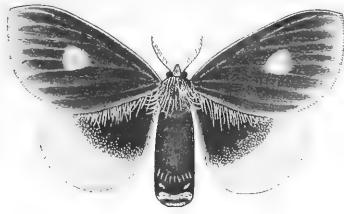

1

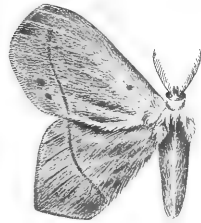

2

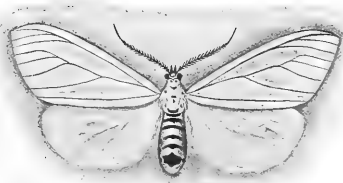

3



4



6



5



7



9



8



10

J. Castro, ad nat. del. 1910.

PLATE I.

NEUE COLEOPTERA LAMELLICORNIA VON DEN
PHILIPPINEN.

Von J. MOSER.
(Berlin, Germany.)

Die im folgenden beschriebenen Arten befanden sich unter dem Material, welches mir das Bureau of Science in Manila zur Bestimmung übersandte, und wurden mir von diesen Arten Doubletten gütigst überlassen.

Macronota luctuosa Voll., subsp. *palawanica* subsp. nov.

Differt a *luctuosa* Voll.: Minor, clyper femoribus tibiisque rufis.—
Long. 17 mill.

Typus No. 10725 in Coll. Ent., Bureau of Science, Manila, P. I.

Hab: PALAWAN, Iwahig, P. I. (W. Schultze collector).

Auf Palawan kommt eine kleine Lokalform der *Macronota luctuosa* Voll., vor. Die Exemplare von Amboina, Sumatra und Nias sind von gleicher Grösse. Während jedoch bei den Exemplaren von Sumatra und Nias, Clypeus und Fühler schwarz sind, sind bei solchen von Amboina der Clypeus und Fühler rotbraun. Auch zeigen bei einigen Exemplaren von letzterer Lokalität die Beine eine pechbraune Färbung. Exemplare von Palawan sind nun bedeutend kleiner und sind bei ihnen der vordere Teil des Clypeus, die Fühler, Schenkel und Schienen rotbraun gefärbt.

Astræa multimaculata sp. nov.

Nigra, supra opaca flavomaculata. Capite punctato, fronte flavo-bivittata, clypeo nitido, antice emarginato; antennis piceis; prothorace disco sparsim lateraliter paulo densius punctato, vittis 5 maculisque 2 an 4 flavis ornato; scutello vitta media flava; scapulis flavis; elytris disco striatis lateraliter aciculato-punctatis, singulis maculis 13–15 flavis ornatis; pygidio flavo, nigro-bivittato, aciculato-punctato, punctis setas minutas flavas ferentibus. Corpore infra medio nitido, lateribus flavo-tomentosis.—Long. 11 mill.

Typus No. 7294 in Coll. Ent., Bureau of Science, Manila, P. I.

Hab: MINDANAO, Camp Keithley, P. I. (Mrs. M. S. Clemens collector).

Die Art, von der zwei männliche Exemplare vorliegen, ist etwas kleiner als *A. tigrina* Mohn., hat dieselbe Zeichnung des Halsschildes aber

zahlreichere gelbe Flecke auf den Flügeldecken. Der glänzende Clypeus ist vorn in der Mitte bogenförmig ausgeschnitten, die Lappen sind abgerundet; Scheitel und Stirn sind matt und mit zwei gelben Längsbinden versehen. Die Fühler sind pechbraun. Das Halsschild hat fünf gelbe Längsbinden, von denen die mittlere weder den Vorder- noch den Hinterrand erreicht, während die vier übrigen, vom Vorderrande ausgehend, hinten verkürzt sind. Vor dem Hinterrande befindet sich jederseits des Schildchens ein gelber Makel und bei dem einen Exemplar ist auch ein kleiner punktförmiger Fleck zwischen den beiden äusseren Binden vorwärts der Mitte vorhanden. Der Discus des Halsschildes zeigt nur eine zerstreute und schwache Punktierung, während die Punkte an den Seiten etwas dichter stehen und hier hufeisenförmig sind. Das Schildchen trägt eine gelbe Längsbinde. Die Flügeldecken zeigen auf dem Discus neben der Naht drei nach vorn und hinten verschwindende Längsnadelrisse und daneben nach dem Aussenrande zu Reihen von nadelrissigen Punkten. Die Naht ist nicht wie bei *tigrina* in eine Spitze ausgezogen. Jede Flügeldecke trägt 13–15 gelbe Flecke, von denen 8 ungefähr an derselben Stelle stehen wie bei *tigrina*, aber eine mehr quere Gestalt haben, während die übrigen, kleineren, auf dem Discus neben der Naht liegen. Das gelb tomentierte Pygidium trägt zwei schwarze Längsbinden. Es hat eine zerstreute hufeisenförmige Punktierung und ist jeder Punkt mit einem gelblichen Börstchen versehen. Die Unterseite ist in der Mitte glänzend und mit vereinzelt Punkten besetzt. Die Seiten sind breit gelb tomentiert und zeigen sich auf dem Abdomen in dieser Tomentbedeckung an jeder Seite drei quere schwarze unbedeckte Flecke. Bei dem einen der beiden vorliegenden Exemplare stehen diese schwarzen Flecken auf dem dritten und vierten Bauchsegment mit der schwarzen Mitte in Verbindung. Die Seiten der Brust sind mit nicht dicht stehenden gelben Haaren besetzt, während die weitläufigen nadelrissigen Punkte des Abdomens kleine gelbliche Borsten tragen. Der Brustfortsatz ist kurz, vorn breit gerundet. Die Vorderschienen sind beim ♂ zweizählig, die inneren Sporen der Hinterschienen sind bei den vorliegenden beiden Exemplaren nicht länger als die äusseren. Der Forceps ist ganz anders gebildet als bei *tigrina*.

Hoplia philippensis sp. nov.

Rufo-picea, dense aureo-squamulata et sparsim flavo-pilosa. Clypeo leviter coriaceo, nitido, postice punctis grossis setiferis tecto; tibiis anticis tridentatis, antennis 9-articulatis.—Long. 5.5 mill.

Typus No. 6026 in Coll. Ent., Bureau of Science, Manila, P. I.

Hab: NEGROS OCCIDENTAL, Maaao, P. I. (*Charles S. Banks* collector).

Die Art gehört zur *aurantiaca*-Gruppe. Sie ist von rotbrauner Färbung und dicht mit goldigen Schuppen bedeckt. Der Clypeus ist unbeschuppt, schwach lederartig glänzend, im hinteren Teile mit sehr groben gelblich beborsteten Punkten. Sämtliche Schuppen sind von

rundlicher Gestalt und unterscheidet sich die Art dadurch leicht von der gleichfalls auf den Philippinen vorkommenden *simplex* Sharp, bei der die Schuppen der Flügeldecken länglich geformt sind. Die kurzen gelblichen Borstenhaare der Flügeldecken stehen in regelmässigen Reihen und zwar fehlt da, wo sich ein Borstenhaar befindet, die Schuppe. In Gestalt und Form der Schuppen hat die Art Ähnlichkeit mit *aurifera* Brnsk. von Borneo, doch sind bei letzterer Art die Vorderecken des Halsschildes stärker vorgezogen und spitzwinklig, bei *philippensis* rechtwinklig.

Hoptia maculifera sp. nov.

Picea, supra dense flavo-squamosa, vittis duabus maculisque nonnullis elytrorum nigro-brunneis, subtus dense aureo-squamulata. Clypeo haud squamoso, subrugoso; tibiis anticis tridentatis, antennis 9-articulatis.—Long. 7 mill.

Typus No. 7225 in Coll. Ent., Bureau of Science, Manila, P. I.

Hab: LUZON, Province of Benguet, Irisan River, P. I. (*R. C. McGregor* collector).

Etwas grösser als die vorhergehende Art, die Form der Schuppen und die borstenartige Behaarung ebenso, aber die Schuppen anders gefärbt, der Clypeus runzelig, so dass die grösseren beborsteten Punkte nicht hervortreten wie bei der vorhergehenden Art. Die Schuppen der Oberseite sind heller oder dunkler gelb gefärbt, die Zeichnungen sind mehr oder weniger dunkelbraun. Auf dem Halsschild befinden sich in der Mitte zwei Längsbinden und sind ausserdem noch zwei äussere angedeutet. Auf den Flügeldecken befindet sich ein Längsfleck unterhalb der Schulter, einer auf dem Discus vor der Mitte und ein fast nierenförmiger hinter der Mitte. Die Schuppen der Unterseite schimmern schwach goldig. Wegen des anders skulptierten Clypeus glaube ich nicht, dass diese Art nur eine Varietät der vorhergehenden ist, wenn gleich auch die Arten der *aurantiaca*-Gruppe ähnlich gefärbte Varietäten zu bilden pflegen.

Lepidiota corpulenta sp. nov.

♀ castanea, supra nitida, parce flavo-squamulata. Capite, fronte sparsim fortiter punctulata, clypeo lateribus rotundatis, margine antico haud exciso, ruguloso-punctato, punctis omnibus flavo-squamosis; antennis 9-articulatis; prothorace antice et postice attenuato, angulis posticis obtusis, anticis fere rectis, paulo prominulis, haud dense fortiter et ruguloso-punctato, punctis squamas minutas ferentibus; scutello semicirculari, parce punctulato; elytris subcostatis, rugoso-punctatis, punctis squamulatis, sutura laevi; pygidio densius cinereo-squamulato-setoso. Subtus pectoris lateribus griseo-villosis, abdominis medio sparsim, lateribus dense cinero-squamulatis; tibiis anticis tridentatis.—Long. 26 mill.

Typus No. 6883 in Coll. Ent., Bureau of Science, Manila, P. I.

Hab: MINDANAO, Camp Keithley, P. I. (*Mrs. M. S. Clemens* collector); CEBU (7431 *A. Celestino*).

Die Art, von der drei weibliche Exemplare vorliegen, gehört zu den kleineren Arten der Gattung Lepidiota, ist von robuster Gestalt und durch neungliedrige Fühler ausgezeichnet. Die Färbung ist braun, die Oberseite ist glänzend und mit nicht dicht stehenden kleinen gelblichen Schüppchen bedeckt. Die Stirn ist kräftig aber zerstreut, der Clypeus grob runzelig punktiert, alle Punkte tragen gelbe borstenartige Schuppen. Das dritte Fühlerglied ist um die Hälfte länger als das vierte. Das Halsschild ist bedeutend breiter als lang, in der Mitte am breitesten, die Hinterecken sind stumpfwinklig, die schwach vorgezogenen Vorderecken fast rechtwinklig. Die Oberfläche ist ebenso wie die des Schildchens nicht dicht aber grob runzelig punktiert und jeder Punkt mit einem kleinen gelblichen Schüppchen versehen. Die Flügeldecken zeigen ausser der glatten, schwach erhabenen Naht, noch 2-3 Rippen, welche sich schwach von der runzelig punktierten und mit kleinen Schuppen versehenen Oberfläche abheben. Das Pygidium ist dichter nadelrissig punktiert und weisslich beschuppt. Die Seiten der Brust sind gelblich-grau behaart, die Mitte der Brust zeigt nur vereinzelte grobe Punkte. Die Mitte des Abdomens ist zerstreut punktiert, die Seiten sind dicht mit borstenartige weissliche Schuppen tragenden Punkten bedeckt. Die Beine sind weiss beborstet, die Vorderschienen dreizählig.

Apogonia metallescens sp. nov.

Nigro-brunnea, nitida, supra vividi et cupreomicans. Capite haud dense punctulato, clypea antice parum emarginato, fortius punctato; antennis piceis; prothorace transverso, angulis posticis rotundatis, angulis anticis prominulis, acutis, disco haud crebre, lateraliter paulo densius punctato et leviteo impresso; scutello dere laevi; elytris postice paulo ampliatis, subrugoso-punctatis, vix costatis; pygidio ruguloso-punctato. Subtus medio subtiliter et sparsim, lateraliter densius et fertius umbilicato-punctata, tibiis anticis bidentatis.—Long. 10-11 mill.

Typus No. 6901 in Coll. Ent., Bureau of Science, Manila, P. I.

Hab.: MINDANAO, Camp Keithley, P. I. (*Mrs. M. S. Clemens* collector).

In Grösse und Gestalt der *A. major* Waterh., von Japan ähnlich, die Flügeldecken jedoch ohne deutliche Rippen. Die Färbung ist schwarzbraun, die Oberseite metallisch grün, teilweise auch kupfrig schimmernd. Die Stirn ist nicht dicht, der Clypeus dichter und etwas gröber punktiert, vorn flach ausgerandet. Das Halsschild ist mehr als doppelt so breit wie lang, die Vorderecken sind etwas vorgezogen, die Hinterecken breit abgerundet; der Discus ist bei dem einen der beiden vorliegenden Exemplare zerstreut, bei dem anderen mässig dicht punktiert; neben den Seitenrändern stehen die Punkte etwas dichter und sind gröber und findet sich hier ein flacher Eindruck. Das Schildchen ist bei dem einen Exemplar ganz glatt, bei dem anderen trägt es einige sehr schwache Punkte. Die Flügeldecken zeigen nur bei schräger Betrachtung

tung schwache Andeutungen von drei Rippen. Sie sind mässig dicht runzelig punktiert, nach den Seiten hin gröber und hier querrunzelig. Das Pygidium zeigt eine sehr kräftige runzelige Punktierung. Unterseits ist die Mitte nur zerstreut und fein punktiert, während an den Seiten die Punkte dichter stehen, gröber sind und äusserst kleine, nur mit der Lupe sichtbare Börstchen tragen. Die Vorderschienen sind zweizählig.

Apogonia nigrobrunnea sp. nov.

Nigro-brunnea, nitida. Capite sat crebre punctato, clypeo brevi, antice subtruncato, ruguloso-punctato; antennis rufis; prothorace transverso, sat dense punctato, lateraliter leviter impresso, angulis posticis rotundatis, angulis anticis paulo prominulis, fere rectis; scutello linea media laevi; elytris postice parum ampliatis, disco subtiliter, lateraliter paulo fortius punctatis, subtricotatis; pygidio dense et fortiter punctato, subcarinato. Subtus medio sparsim, lateraliter densius punctata, punctis setas minutas ferentibus; tibiis anticis tridentatis.—Long. 1 $\frac{1}{2}$ mill.

Typus No. 991 in Coll. Ent., Bureau of Science, Manila.

Hab: Luzon, Province of Benguet, Irisan River, P. I. (*R. C. McGregor* collector).

In Gestalt der vorigen Art ähnlich von schwarzbrauner Färbung, stark glänzend, metallisch schimmernd. Der Kopf ist mässig dicht, an der Clypeusnaht weitläufiger punktiert, der Clypeus ist vorn fast gerade abgestutzt und grob, beinahe runzelig punktiert. Die Fühler sind rotgelb. Das Halsschild ist sehr quer, mässig dicht, auf den Seiten etwas runzelig punktiert, jederseits neben den Seitenrändern mit schwachem Eindruck. Die Hinterecken sind breit abgerundet, die etwas vorgezogenen Vorderecken beinahe rechtwinklig. Das Schildchen lässt eine glatte Mittellinie erkennen. Die nach hinten schwach erweiterten Flügeldecken sind etwas weitläufiger punktiert als das Halsschild. Auf dem Discus sind die Punkte schwach, an den Seiten etwas kräftiger. Ausserdem erscheinen die Flügeldecken schwach quergorunzelt. Die drei Rippen sind sehr undeutlich, die erste verbreitert sich nach hinten. Das Pygidium ist sehr grob punktiert und trägt in der Mitte einen undeutlichen Längskiel. Die Unterseite zeigt in der Mitte zerstreute, an den Seiten dichter stehende Punkte und ist jeder Punkt mit einem sehr kleinen gelblichen Börstchen versehen. Die Vorderschienen sind kräftig dreizählig.

Apogonia viridana sp. nov.

Convexa, viridis, nitida; antennis, pygidio pedibusque brunneis. Capite, fronte fortiter punctulata, clypeo antice truncato, ruguloso-punctato; prothorace longitudine duplo latiore, sparsim punctato, angulis posticis obtusis, subrotundatis, angulis anticis fere rectis, paulo prominulis; scutello fere laevi; elytris subrugoso-punctatis, indistincte bicostatis; propygidio pygidioque fortiter ruguloso-punctatis, punctis squami-

feris. Corpore infra medio sparsim punctato, lateribus sat dense flavo-squamosis; tibiis anticis bidentatis.—Long. 7 mill.

Typus No. 10660 in Coll. Ent., Bureau of Science, Manila, P. I.

Hab: LUZON, Cagayan, Camalaniogan, P. I. (*H. M. Curran* collector).

Eine kleinere gewölbte Art, grün, glänzend, Fühler, Propygidium, Pygidium und Beine braun, Halsschild und Kopf bei dem einen der beiden vorliegenden Exemplare etwas kupferig. Die Stirn ist mässig dicht mit tiefen Punkten bedeckt, der vorn fast gerade abgestutzte Clypeus ist dicht, fast runzelig punktiert. Das Halsschild trägt nur eine zerstreute Punktierung, die stumpfen Hinterecken sind fast abgerundet, die etwas vorgezogenen Vorderecken ungefähr rechtwinklig. Das Schildchen ist bei dem einen der beiden Exemplare ganz glatt, bei dem anderen sind einige schwache Punkte erkennbar. Die Flügeldecken sind zwar nicht sehr dicht aber grob und namentlich nach den Seitenrändern zu runzelig punktiert. Zwei Rippen auf dem Discus treten nur wenig hervor, die Naht ist fast glatt, neben den Seitenrändern befinden sich fünf regelmässige Punktreihen. Propygidium und Pygidium sind mit groben Punkten bedeckt, so dass sie stark runzelig erscheinen. Jeder dieser Punkte trägt ein kleines gelbes Schüppchen. Die Mitte der Brust ist zerstreut punktiert, die Bauchsegmente zeigen in der Mitte eine Querreihe von beborsteten Punkten, die Seiten der Brust und des Abdomens sind ziemlich dicht mit gelblichen Schuppen bedeckt. Die Vorderschienen sind zweizählig.

Die Art scheint der mir unbekannteren *A. magnifica* Rits. nahe zu stehen, doch ist diese grösser und hat dreizählige Vorderschienen.

Apogonia lutea sp. nov.

Elongata, lutea, nitida, capite thoraceque obscurioribus. Fronte haud dense punctulata, clypeus antice parum emarginato, fortiter punctato; antennis testaceis; prothorace valde transverso, disco sparsim versus margines laterales densius punctato, angulis posticis rotundatis, angulis anticis prominulis; scutello laevi; elytris haud crebre fortiter punctatis, disco bicostatis, sutura costique fere laevibus; pygidio sparsim punctato, punctis in posteriore parte flavo-pilosis. Subtus medio fere laevi, lateribus fortiter haud dense punctatis, punctis setas minutas ferentibus; tibiis anticis tridentatis.—Long. 9 mill.

Typus No. 7223 in Coll. Ent., Bureau of Science, Manila, P. I.

Hab: LUZON, Province of Benguet, Irisan River, P. I. (*R. C. McGregor* collector).

Von länglicher Gestalt, nach hinten schwach verbreitert schmutzig gelb, Kopf, Halsschild, Schienen und Tarsen bräunlich. Die Stirn ist mässig dicht mit ziemlich kräftigen Punkten besetzt, der vorn schwach ausgerandete Clypeus trägt eine sehr grobe Punktierung, so dass er fast runzlig erscheint. Das Halsschild ist auf dem Discus weitläufig, nach

den Seiten zu enger punktiert, die Hinterecken sind abgerundet, die Vorderecken etwas vorgezogen. Die Flügeldecken zeigen auf dem Discus eine unregelmässige, ziemlich grobe Punktierung und markieren sich zwei Rippen dadurch, dass sie ebenso wie die Naht fast punktfrei sind und von Punktreihen begrenzt werden. Neben den Seitenrändern der Flügeldecken befinden sich mehrere regelmässige Punktreihen. Das Pygidium zeigt eine weitläufige Punktierung und tragen die Punkte im hinteren Teile abstehende gelbe Haare. Die Unterseite ist in der Mitte fast glatt, dagegen findet sich an den Seiten eine kräftige aber nicht besonders dichte Punktierung; die Punkte sind mit kleinen gelblichen Börstchen besetzt. Die Vorderschienen sind dreizählig.

Apogonia rugipennis sp. nov.

Elongata, fusca, nitida, flavo-pilosa. Capite rugoso-punctato, clypeo antice emarginato; prothorace transverso, sat dense fortiter subruguloso-punctato, angulis posticis rotundatis, angulis anticis fere rectis, vix prominulis; scutello dense punctato; elytris rugoso-punctatis, indistincte bicostatis; pygidio conico, fortiter et profunde punctato. Subtus sat dense punctata; tibiis anticis tridentatis.—Long. 9 mill.

Typus No. 7235 in Coll. Ent., Bureau of Science, Manila, P. I.

Hab: LUZON, Province of Benguet, Irisan River, P. I. (*R. C. Mc-Gregor* collector).

Von länglicher Gestalt, unten heller oben dunkler braun, das Halsschild und der Kopf, mit Ausnahme des Clypeus, schwach grün metallisch schimmernd. Die ganze Oberseite und Unterseite sind mit sehr feinen, nicht dicht stehenden Härchen bedeckt, welche auf der Unterseite anliegen, auf der Oberseite schwach aufgerichtet sind. Der Kopf ist sehr runzelig punktiert, der Clypeus vorn ausgerandet. Das Halsschild zeigt eine grobe Punktierung, die Zwischenräume zwischen den Punkten sind schwach runzelig; die Hinterecken sind abgerundet, die fast rechtwinkligen Vorderecken kaum vorgezogen. Das Schildchen ist auf der ganzen Fläche punktiert. Auf den grob und runzelig punktierten Flügeldecken markieren sich zwei Rippen nur sehr undeutlich. Das Pygidium ist stumpf kegelförmig und trägt sehr grosse und tiefe Punkte. Die ganze Unterseite ist ziemlich dicht punktiert, nur auf der Mitte der Brust stehen die Punkte etwas weitläufiger. Die Vorderschienen tragen drei Zähne, von denen die beiden untersten sehr kräftig sind.

FILIPINO EARS, II: EARS FROM THE MALECON MORGUE.

By ROBERT BENNETT BEAN.

(From the Anatomical Laboratory, Philippine Medical School.)

The ears of all the unclaimed bodies that remained in the Manila City Morgue during a short period of time are presented here in three plates to illustrate the Primitive, the Iberian, and various forms of blended ears. The individuals represent a small section of a random sample of the lower strata of Manila's population. There are in all 19 adult male and 7 adult female Filipinos and 1 adult male Russian. A table containing the stature, cephalic index and nasal index of the subjects is given so that the physical characteristics of the individual may be compared with the ear type.

The Iberian ears are shown in Plate I. The ears in the upper row are Iberian Type A; those in the middle row are Iberian Type B; and those in the lower row are Iberian Type D. The most characteristic ear of each type is placed on the left; the others are modified forms. Photographs of both the right and left ear of each subject are reproduced in two positions: First, the side view of each; then the right ear from behind and the left ear from in front.

Detailed descriptions are unnecessary, but a few salient facts may be mentioned. The essential characteristics of the Iberian ear are seen in the inversion of the concha and the rolling out of the helix. This gives a shallow bowl in the concha and a flat helix below. The whole ear assumes a flat appearance and is usually placed parallel to the head rather than at right angles. The rim of the helix is shaped like the italic letter *f* or the old English or German *ff*, which can be seen when the ear is looked at from behind. The ear is thin, the lines of the skin are fine, and the skin is smooth in appearance, but harsh to the touch.

The Modified Primitive ears of Plate II are arranged in the order of increasing modification from the upper left-hand corner to the lower right-hand corner of the plate. The Primitive ear is characterized by inversion of the concha and rolling in of the helix. The upper and lower parts of the latter project in the formation of a shelf. The concha is deep and resembles a bowl. Viewed from behind, the flat dorsal surface

of the bowl may be seen, and the upper part of the helix and the lower part of the lobule appear to be the lips of the bowl. The ear is thick, the skin lines are coarse, and the skin is rough in appearance, but feels like velvet.

Ear No. 87 is notable because it was removed from the head of a Russian; on the right it is Modified Iberian, whereas on the left it is Modified Primitive. The physical characteristics of this individual resemble the Blends, moderately brachy-cephalic, leptorrhine and tall. The man was no doubt a mixture of the Iberian from Europe and the Primitive from Siberia.

Plate III represents ears that appear to be fused Iberian and Primitive. In each ear there are characteristics of both, but they are different from either, and the physical characteristics are those of the Australoid type. It may also be worthy of note that the physical characteristics of the individuals with the modified Iberian ears of Plate I are largely Iberian and the physical characteristics of the individuals with the Modified Primitive ears of Plate II are largely Primitive.

The cephalic index is not so good a criterion of type as the ear form, because it is seen that the average cephalic index of the subjects with Iberian characteristics is almost as great as that of those with Primitive markings. The nasal index for the same reason is a better indicator than the stature. Stature and cephalic index may be so altered by the environment as to become of no service in the determination of type; therefore, other factors should be emphasized for this purpose. The ear form and the nasal index are more stable and less influenced by environment; therefore they are better factors than the other two.

TABLE I.—(See PLATE I.)

Type.	No.	Cephalic index.	Nasal index.	Stature.
Iberian	93	78.0	86.0	151.0 ♀
B. B. B	94	88.4	71.4	170.8 ♂
Blend	96	83.3	80.0	166.8 ♂
Iberian	74	81.0	73.0	153.0 ♀
Blend	72	85.3	90.5	160.0 ♂
Iberian	95	78.0	76.0	163.5 ♂
Iberian	79	77.6	78.8	161.2 ♀
Alpine	69	86.0	72.0	150.0 ♀
Blend	80	82.0	78.0	154.2 ♀
Average		{ 83.8 ♂ 80.9 ♀ }	78.4	{ 165.3 ♂ 153.9 ♀ }

TABLE II.—(See PLATE II.)

Type.	No.	Cephalic index.	Nasal index.	Stature.
Modified Primitive.....	76	82.5	97.0	165.2 ♂
Modified Primitive.....	77	84.8	102.5	160.0 ♂
Adriatic.....	90	80.0	91.0	170.5 ♂
Adriatic.....	70	90.2	89.0	173.0 ♂
Modified Primitive.....	82	80.0	105.0	164.5 ♂
Blend.....	85	84.0	80.0	162.7 ♂
Blend.....	66	82.0	79.0	150.4 ♂
Blend.....	78	81.0	84.0	162.7 ♂
Blend.....	87	82.0	71.0	175.5 ♂
Average.....		83.1	90.3	163.6 ♂

TABLE III.—(See PLATE III.)

Type.	No.	Cephalic index.	Nasal index.	Stature.
Primitive.....	64	89.7	91.0	140.5 ♀
Blend.....	84	87.0	82.0	168.5 ♂
Australoid.....	91	83.9	108.1	143.5 ♂
Australoid.....	71	86.0	98.0	155.0 ♀
Australoid.....	86	71.0	85.0	146.0 ♂
Iberian.....	92	77.9	81.6	162.7 ♂
Blend.....	100	85.0	87.0	157.7 ♂
Australoid.....	89	77.0	102.5	153.6 ♂
Iberian.....	98	78.0	78.0	160.3 ♂
Average.....		81.7	90.3	143.3 ♀

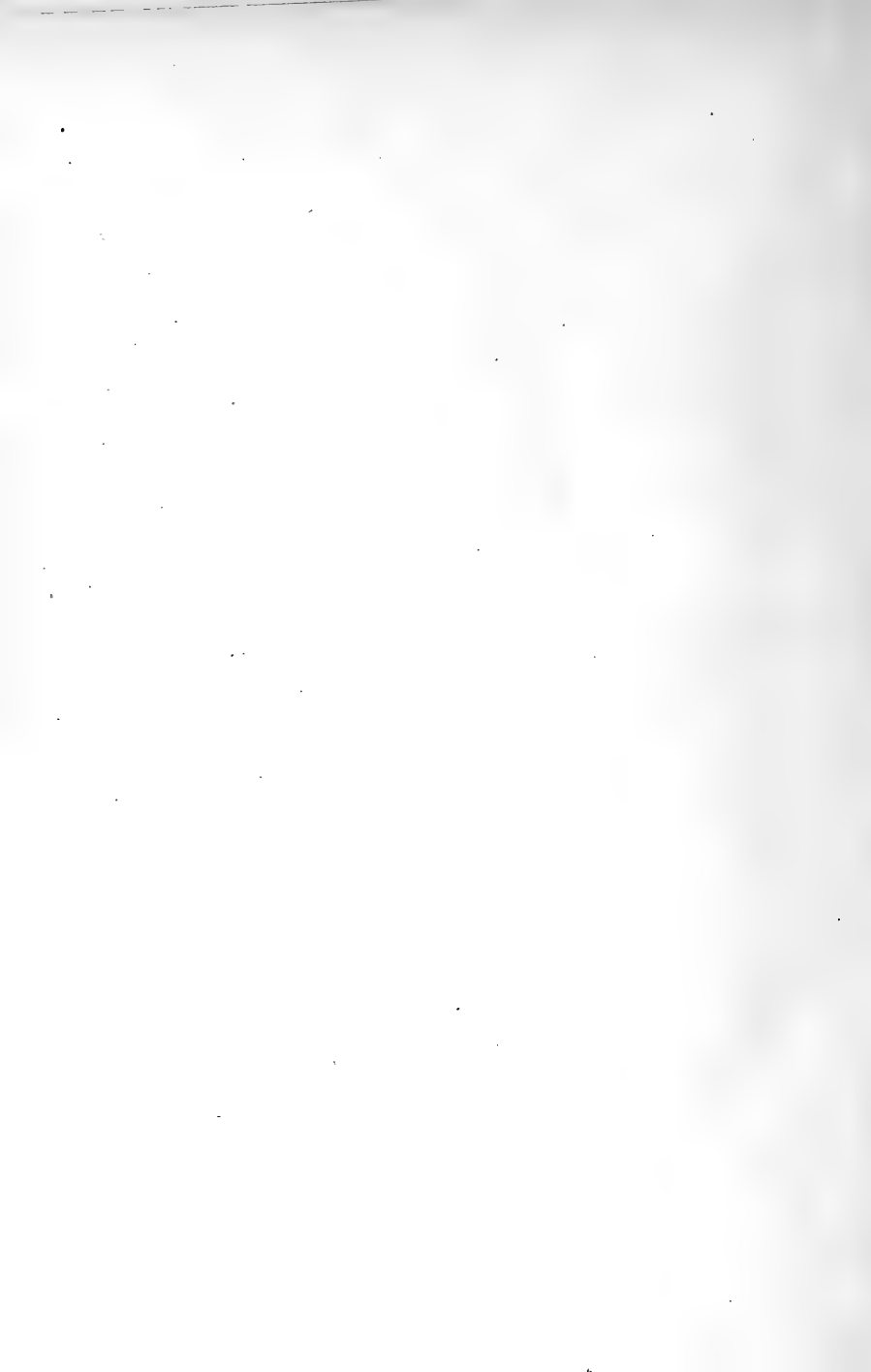

ILLUSTRATIONS.

PLATE I. Modified Iberian ears.

- No. 93, Iberian.
- No. 94, B. B. B.
- No. 96, Blend.
- No. 74, Iberian.
- No. 72, Blend.
- No. 95, Iberian.
- No. 79, Iberian.
- No. 69, Alpine.
- No. 80, Blend.

II. Modified Primitive ears.

- No. 76, Modified Primitive.
- No. 77, Modified Primitive.
- No. 90, Adriatic.
- No. 70, Adriatic Modified.
- No. 82, Primitive.
- No. 85, Blend.
- No. 66, Blend.
- No. 78, Blend.
- No. 87, Blend.

III. Blended ears.

- No. 64, Primitive.
- No. 84, Blend.
- No. 91, Australoid.
- No. 71, Australoid.
- No. 86, Australoid.
- No. 92, Iberian.
- No. 100, Blend.
- No. 89, Australoid.
- No. 98, Iberian.



93



93



49



49



94

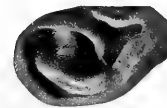

94

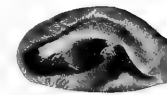

96



96

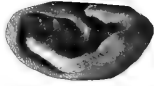

74



74



72



72

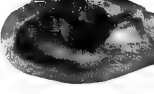

95

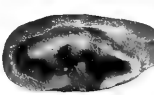

95

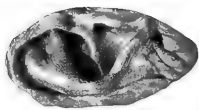

79



79

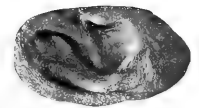
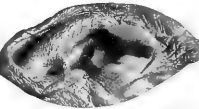

69



69



80

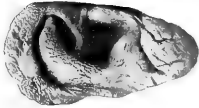

80





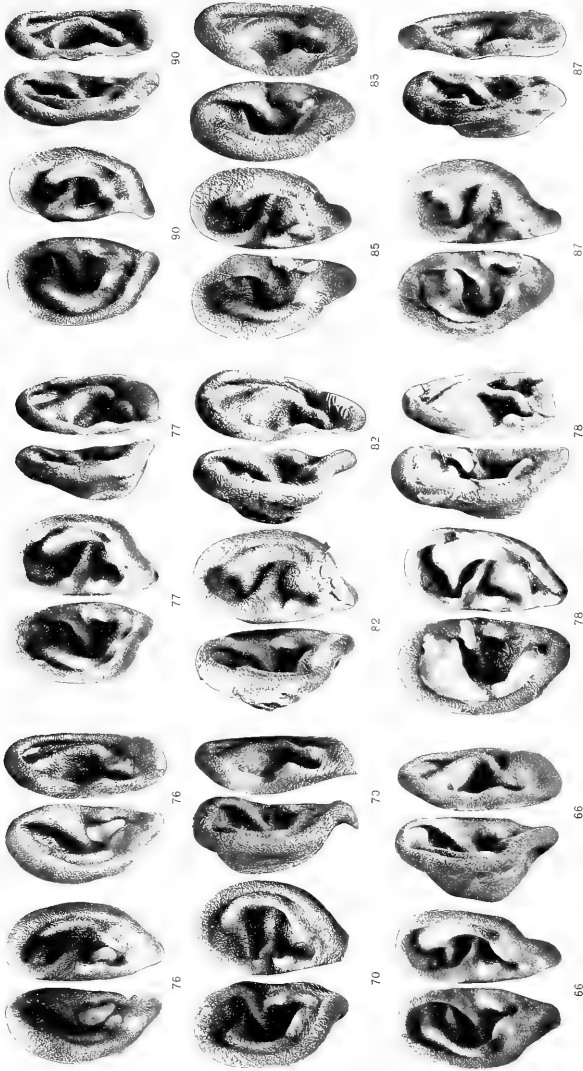

MODIFIED PRIMITIVE EARS.
PLATE II.



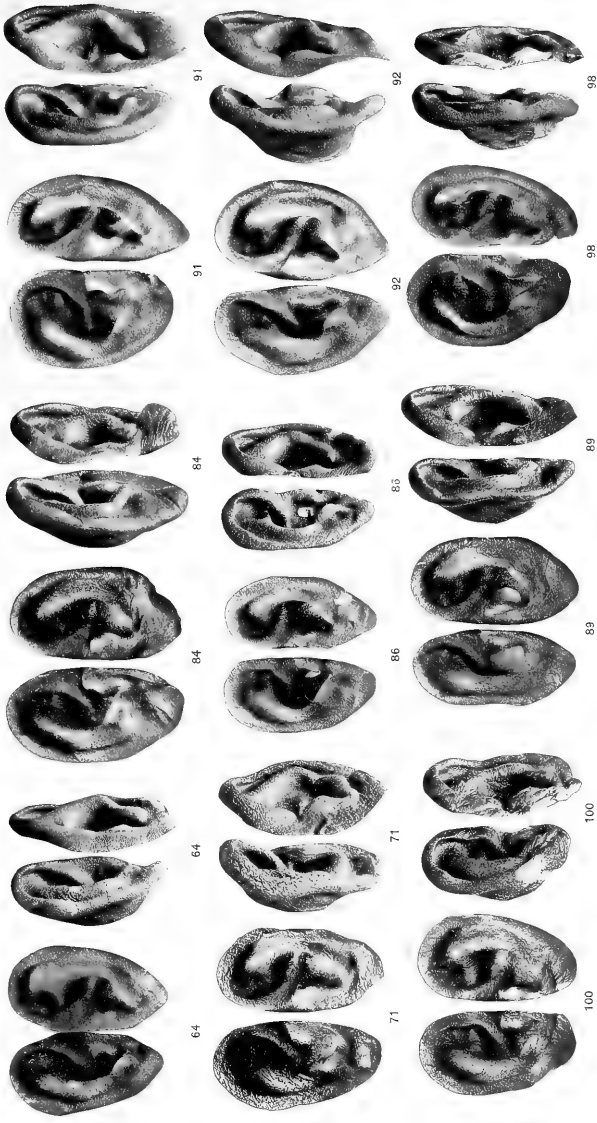

BLENDED EARS.
PLATE III.

ADDITIONAL NOTES ON BIRDS FROM NORTHERN
MINDANAO, PHILIPPINE ISLANDS.

By RICHARD C. MCGREGOR.

(From the Ornithological Section, Biological Laboratory, Bureau of Science,
Manila, P. I.)

In 1907 Mr. Andres Celestino made a small collection of birds in northern Mindanao;¹ recently (1909) he again collected on the Agusan River, securing several specimens worthy of record.

Anous stolidus (Linnaeus).

A male was caught on the Agusan River on the last day of December. The collector tells me that the bird made no effort to fly and seemed to have been wounded.

Herodias timoriensis (Lesson).

A female was taken, December 17, on the Agusan River at some distance from the coast. The longer dorsal plumes extend 30 to 40 millimeters beyond the tip of tail; tarsus, 126 millimeters.

Mareca penelope (Linnaeus).

One male in worn plumage was killed near Bunauan, Agusan River, on December 17.

Lophotriorchis kieneri (Geoffroy St. Hillaire).

One specimen from Bunauan is similar to the immature male from Tablas² except that the thighs are banded with light brown and the upper parts are whiter.

Baza magnirostris Gray.

One female from Bunauan, December 17, is the third specimen of this species to be recorded from Mindanao.

Polioaëtus ichthyætus (Horsfield).

One female from Bunauan, December 17.

Alcyon argentata (Tweeddale).

One male from Bunauan.

¹ *This Journal*, Sec. A (1909), 4, 67-77.

² *This Journal* (1906), 1, 772.



NOTE ON THE MIGRATION OF THE TIC-WEE BUZZARD IN THE PHILIPPINE ISLANDS.

By RICHARD C. MCGREGOR.

(From the Ornithological Section, Biological Laboratory, Bureau of Science,
Manila, P. I.)

The gray-faced buzzard-eagle or Javan buzzard, *Butastur indicus* (Gmelin), is the commonest and most widely distributed falconid in the Philippines. It has been definitely recorded from not less than twenty-seven islands of the Archipelago. Its general distribution as given by Blanford¹ is Eastern Asia from Japan and China to the Malayan Peninsula and Islands as far as the Philippines, Celebes, and New Guinea.

This species is migratory in a large part of its range and it is on this phase of its life history that I wish to record a few notes. I will first quote a paragraph from Meyer and Wigglesworth² as being of particular interest in this connection.

It is possible to show that this species occurs in the East Indian Archipelago only as a migrant from China, Ussuriland, and Japan during the northeast monsoon, the winter in the latter countries. Such Mr. Whitehead considered it undoubtedly to be in Borneo, and Mr. Everett states that "it appears in Labuan and Northern Borneo in September and remains through the winter. It is quite the most abundant of the migratory as *Haliastur intermedius* is of the [page 47] resident birds of prey in those parts of the island." Mr. Whitehead also remarks it as a migrant in Palawan. Abbé David states that it breeds in the mountains near Peking, although it appears not to be plentiful in China; further south it passes through the lower Yangtse country, as Mr. F. W. Styan writes, "on migration in March and April. A good number travel together, and remain a week or so among the hills on their way; they seem to avoid the plains." Apparently the species is resident, or some remain to breed, in the Philippines, an egg, which appears to belong to this species, having been obtained in Mindanao by Schadenberg and Koch.

Oates³ records an egg of this species from "Eastern Siberia 29th April (*Dörries*)." This egg is "a regular oval in shape, smooth, fairly glossy, and plain white with a very slight tinge of blue."

¹ Fauna Brit. Ind., Birds (1895), 3, 365.

² Birds of Celebes (1898), 1, 46.

³ Cat. Birds' Eggs (1902), 2, 278.

At favorable points in the Philippine Islands the tic-wee buzzard may be observed passing in great numbers during its autumn migration. In the Island of Calayan I noted this species first on September 18, 1903. On October 14 large flocks were seen and, on the 17th and 18th of the same month, great numbers of birds passed overhead, in a southerly direction, in long, straggling bands.

While I was on Batan Island in 1907, Mr. William Edmonds informed me that numbers of hawks visited Batan each year between October 10 and 20. Later, Mr. Edmonds sent me a specimen of *Butastur indicus*. In December 1908, through the courtesy of Lieutenant-Commander McCormick, of the *Albatross*, three living specimens of *B. indicus* were brought to the Bureau of Science. Two of these had been forwarded by Mr. Otto Sheerer and one had been caught aboard the *Albatross* in the vicinity of Camiguin Island.⁴ The following letter to Mr. Dean C. Worcester from Mr. Sheerer contains interesting notes on the habits of the tic-wee buzzard and on the methods of its capture by the natives.

By U. S. ship *Albatross* I beg to send you a pair of those falcons which visit our islands every year in the month of October. At that time the natives of Ivana (Batan) erect on the loftiest ridges behind the pueblo rude watch towers consisting of nothing more than four poles some 15 to 20 feet long stuck in the ground upright, or, better, in a slanting position, overhanging the steep side of the mountain and forming a square of some 4 feet each side, joined in the middle by crosspieces and covered in on top with a mass of branches and leaves. Some 3 feet underneath this thin thatch there is a sort of flooring on which the hunter mounts. The birds arrive regularly at dusk, say 6 p. m. They arrive pretty much tired out and gladly avail themselves of these tree-resembling scaffolds or towers to rest their wings over night. Scarcely settled down to rest, the man underneath reaches out and pulls the struggling bird in by the feet. Thus, a lucky hunter may secure two or three at a sitting. I have tried the thing myself, but the night happened to be cloudy and stormy, and as by 7 o'clock no birds had arrived, as it sometimes happens in such weather, my guide called the game off. I secured, however, these two which had been caught the previous night. They came from the northwest and leave the next day for the southwest. They are fed best on chicken entrails or fish and they seem to prefer their food presented to them stuck on the sharp point of a split bamboo stick.

One of the birds sent by Mr. Sheerer was photographed in Manila and is shown on Plate I.

⁴Man. Philippine Birds (1909), 230.

ILLUSTRATIONS.

PLATE I. *Bustatur indicus* (Gmelin). (From photographs by Charles Martin.)

McGREGOR: MIGRATION OF THE TIC-WEE BUZZARD.]

[PHIL. JOURN. SCI., VOL. V, NO. 3.



PLATE I.



PHILIPPINE ORNITHOLOGICAL LITERATURE, III.

By RICHARD C. MCGREGOR.

(From the Ornithological Section, Biological Laboratory, Bureau of Science,
Manila, P. I.)

Bourns, F. S. and Worcester, D. C.: Preliminary notes on the birds and mammals collected by the Menage scientific expedition to the Philippine Islands. *Minnesota Acad. Nat. Sci. Occ. Papers* (1884), **1**, No. 1, 1-64.

A very interesting paper containing descriptions of 36 new species of birds; new localities for 226 species previously known from the Islands; two species, *Caprimulgus jotaka* and *Prionochilus modestus*, recorded from the Philippines for the first time; and additional descriptions and notes concerning some 40 previously little known species. The new species described are: *Ninox spilonotus*, *Phabotreron cinereiceps*, *P. brunneiceps*, *P. maculipectus*, *P. frontalis*, *Phloganas menagei*, *Batrachostomus menagei*, *Ceyx nigrirostris*, *Centropus steerii*, *Iyngipicus menagei*, *Chibia menagei*, *Oriolus cinereogenys*, *O. nigrostriatus*, *Æthopyga arolasi*, *Æ. bonita*, *Æ. minuta*, *Dicaeum pallidior*, *D. sibuyanica*, *D. intermedia*, *D. assimilis*, *Prionochilus ceruginosus*, *P. bicolor*, *Zosterops siquijorensis*, *Hyloterpe winchelli*, *H. major*, *H. mindorensis*, *Cryptolopha flavigularis*, *Geocichla cinerea*, *Cittocinclia superciliaris*, *Ptilocichla minuta*, *Iole cinereiceps*, *I. monticola*, *Muscicapula samarensis*, *Rhipidura sauli*, *Rhinomyias albigularis*, and *R. ocularis*.

Bourns, F. S.: A list of the birds known to inhabit the Philippine and Palawan Islands, showing their distribution within the limits of the two groups. See under Worcester and Bourns.

Clarke, W. E.: On some birds from the Island of Negros, Philippines. *Ibis*. (1894), **VI**, 6, 532-535.

A list of 25 species of which *Chatura celebensis* is recorded from the Philippines for the first time and *Cinnyris guimarasensis*, *Pelargopsis gigantea*, *Thriponax hargitti*, *Spilornis holospilus*, and *Gallierex cinerea* are recorded as new to Negros.

Clarke, W. E.: On some birds from the Island of Negros, Philippines. (Second contribution). *Ibis* (1895), **VII**, 1, 472-479.

Notes on 12 species; *Falco atriceps* is recorded as new to the Philippines.

Clarke, W. E.: On some birds from the Island of Negros, Philippines. Part III. *Ibis* (1898), **VII**, 4, 119-124.

Notes on 41 species, of which 6 are recorded as new to Negros, viz: *Hirundo gutturalis*, *Caprimulgus manillensis*, *Microhierax erythrogenys*, *Porzana fusca*, *Amaurornis olivacea*, and *Gallinula chloropus*.

Clarke, W. E.: On some birds from the Island of Negros, Philippines. Part IV. *Ibis* (1900), VII, 6, 351-361, pl. 8.

Notes on 26 species, of which *Phlogocanus keayi*, new species, is described and figured; an unknown *Batrachostomus* and the female of *Caprimulgus griseatus* are described; *Ardea sumatrana*, *Dupetor flavicollis*, and *Nannocnus eurythmus* are recorded as new to Negros.

Dillwyn, L. L.: On an undescribed species of *Megapodius*. *Proc. Zool. Soc. London* (1851), 118-120, pl. 39.

Description and plate of *Megapodius cummingii*, new species, with notes on the nesting habits of the Bornean species.

Elliot, D. G.: On the fruit-pigeons of the genus *Ptilopus*. *Proc. Zool. Soc. London* (1878), 500-575, pls. 33 and 34, text figs. 1-6.

An elaborate review of the genus and of its literature with descriptions, synonyms, and key to the species.

Finsch, O.: Ueber einen Neuen Nashornvogel der Gattung *Penelopides* Reichb. *Notes Leyden Mus.* (1903), 23, 190-194.

Description of *Penelopides talisi*, new species, from Cagayan, northern Luzon.

McGregor, R. C.: On birds from Luzon, Mindoro, Masbate, Ticao, Cuyo, Cagayan Sulu, and Palawan. *Bull. Philippine Mus.* (1903), No. 1, 1-12.

Chibia cuyensis is described as new. Six species, either new to the Islands or of uncertain status, are noted: *Querquedula querquedula*, *Spatula clypeata*, *Phalacrocorax carbo*, *Tachornis infumata*, *Uroloncha fuscans*, and *Sturnia sinensis*. Descriptions or notes of interest are recorded for the following: *Caprimulgus griseatus*, *Oriolus albiloris*, *O. isabellæ*, *Orthotomus chloronotus*, *Nettopus coromandelianus*, *Fuligula fuligula*, *Collocalia marginata*, *Cinnyris whiteheadi*, *Anthothreptes griseigularis*, *Cittocincla superciliaris*, and *Cyanomyias caelestis*. New localities for species are recorded as follows: Luzon, 5 species; Mindoro, 1 species; Culion, 3 species; Palawan, 1 species; Cagayan Sulu, 12 species; Cuyo, 22 species; Masbate, 10 species; Ticao, 91 species.

McGregor, R. C.: Birds from Benguet Province, Luzon, and from the Islands of Lubang, Mindoro, Cuyo, and Cagayancillo. *Bull. Philippine Mus.* (1904), No. 3, 1-16.

Pericrocotus novus is fully described for the first time and notes of interest on about 40 species are recorded. From Lubang 73 species are recorded; from Verde, 35 species; from Agutaya, 8 species; from Cagayancillo, 45 species; to the Mindoro list 16 are added; to the Cuyo list 15 are added. This paper ends with a list of 72 species from Benguet Province, Luzon.

McGregor, R. C.: The Birds of Calayan and Fuga, Babuyan Group. *Bull. Philippine Mus.* (1904), No. 4, 1-34.

This paper includes descriptions and records of several species which come from neither Calayan nor Fuga and unfortunately their places of capture are not always clearly indicated. The new species are: *Turnix worcesteri*, *Macropygia phæa*, *Otus cuyensis*, *O. calayensis*, *Eudynamis frater*, *Zosterops flavissima*, and *Hyloterpe fallax*. The following are recorded as new from the

Philippines: *Oceanodroma*, species, *Sterna fluviatilis*, *Polionetta zonorhyncha*, *Mareca penelope*, *Spodiopsar sericeus*, *Chrysomitris spinus*, *Saxicola ananthe*, *Acrocephalus sorgophilus*, *Chelidon dasyopus*, *Clivicola riparia*, *Astur cuculoides*, *Turdus pallidus*, *Antigone sharpei*, and *Fringilla montifringilla*.

- **McGregor, R. C. and Worcester, D. C.:** A handlist of the birds of the Philippine Islands. *Publ. Bu. Govt. Labs. Manila* (1906), No. 36, 1-100.

An enumeration of 693 species with their orders, families, and genera, and with the exact distribution of each species within the Archipelago. This is a useful list.

- Mearns, E. A.:** Descriptions of a new genus and eleven new species of Philippine birds. *Proc. Biol. Soc. Washington* (1905), 18, 1-8.

Leonardia, new genus; *Leonardia woodi*, *Pseudotharrhaleus mindanensis*, *Macronus mindanensis montanus*, *Æthopyga boltoni*, *Cyrstostomus dinagatensis*, *Anthreptes cagayanensis*, *Merula kelleri*, *Gerygone rhizophoræ*, *Muscicapula montigena*, *Pardaliparus elegans mindanensis*, new species.

- Mearns, E. A.:** Descriptions of eight new Philippine birds, with notes on other species new to the Islands. *Proc. Biol. Soc. Washington* (1905), 18, 83-90.

Turnix suluensis, *Muscadivora langhornei*, *Caprimulgus affinis mindanensis*, *Phyllergates heterolæmus*, *Cephalophonus suluensis*, *Hyloterpe apoensis*, *Dicaeum davao*, and *Lamprocorax todayensis* are described as new. *Leonardina* is proposed in place of *Leonardia* Mearns, preoccupied. Seven species are recorded from the Islands for the first time, namely: *Limonites minutus*, *Hydractator gallinaceus*, *Plegadis falcinellus*, *Herodias timoriensis*, *Loriculus galgulus*, *Collocalia francaica inexpectata*, and *Hirundo rustica rustica*.

- Mearns, E. A.:** Note on a specimen of *Pithecophaga jefferyi* Ogilvie-Grant. *Proc. Biol. Soc. Washington* (1903), 18, 73.

Record and measurements of a specimen from Mindanao.

- Mearns, E. A.:** Two specimens of *Chatura celebensis* (Sclater). *Proc. Biol. Soc. Washington* (1905), 18, 185.

Record and measurements of two specimens from Basilan.

- Mearns, E. A.:** Two additions to the avifauna of the Philippines. *Phil. Journ. Sci.* (1907), 2, Sec. A, 353.

Butorides spodiogaster and *Spodiopsar cineraceus* recorded for the first time from the Philippines.

- Mearns, E. A.:** Descriptions of a new genus and nine new species of Philippine birds. *Phil. Journ. Sci.* (1907), 2, Sec. A, 355-360.

Malindangia, new genus; *Malindangia mcgregori*, *Cyornis mindorensis*, *Centropus carpenteri*, *Rhipidura hutchinsoni*, *Hypsipetes batanensis*, *Merula malindangensis*, *M. mayonensis*, *Geocichla mindanensis*, *Zosterops halconensis*, new species. A key to the Philippine species of *Merula* is also given.

- Moseley, E. L.:** Descriptions of two new species of flycatchers from the Island of Negros, Philippines. *Ibis* (1891), VI, 3, 46-47, pl. 2.

Cryptolopha nigrorum and *Abrornis olivacea* are described and figured.

Slater, P. L.: Report on the birds. Report on the scientific results of the voyage of H. M. S. *Challenger* during the years 1873-76 under the command of Capt. George S. Nares, R. N., F. R. S. and Capt. Frank Tule Thomson, R. N. prepared under the superintendence of Sir C. Wyville Thomson Knt. F. R. St. etc. (1881), Zool. 2, 5-25, pls. 1-6.

Two of the papers deal with Philippine birds. I. On the birds collected in the Philippine Islands, pp. 5-25, pls. 1-6, being a republication from the Proc. Zool. Soc., 1877. The species figured are: *Loriculus panayensis*, *Batrachostomus septimus*, *Buceros mindanensis*, *Dicrurus striatus*, *Dicaeum mindanense*, *Nectarophila julie*, and *Phabotreron brevirostris*.

The other paper is: X. On the Laridæ collected during the Expedition, pp. 133-140, being a republication of Saunder's paper from the Proc. Zool. Soc. 1877. The Philippine specimens recorded are: *Hydrochelidon hybrida* and *Larus ridibundus* from Manila, and *Sterna bergii* from Zamboanga.

Sharpe, R. B.: List of a collection of birds made by Mr. L. Wray in the main range of mountains in the Malay Peninsula, Perak. Proc. Zool. Soc. London (1888), 268-287.

Muscicapula westermanni, new species, is described in this paper.

Sharpe, R. B.: Notes on some species of birds of the family Dicæidæ. Proc. Zool. Soc. London (1883), 578-580.

In this paper *Dicaeum schistaceum* Tweeddale is considered to be the young of *D. rubriventer* Lesson and *D. modestum* Tweeddale the young of *D. evretti*.

Sharpe, R. B.: Contributions to a history of the Accipitres or birds of prey.—I. On the females of the common and South-African Kestrels. Proc. Zool. Soc. London (1874), 550-584; pl. 68.

The female of *Cerchneis tinnunculus* is figured.

Sharpe, R. B.: On the genus *Alcyone*. Proc. Zool. Soc. London (1869), 351-357.

Key to and descriptions of all the then known species of *Alcyone*.

Sharpe, R. B.: Additional notes on the genus *Ceyx*. Proc. Zool. Soc. London (1869), 507-511.

A comparison of the arrangement of the species of *Ceyx* as given by Sharpe and by Salvadori, with a key, and with remarks on *Ceyx rufidorsa* and *C. sharpii*.

Sharpe, R. B.: On the genus *Ceyx*. Proc. Zool. Soc. London (1868), 587-599.

A review of the genus with key to and descriptions of the species.

Sharpe, R. B.: On the genus *Pelargopsis*, Gloger. Proc. Zool. Soc. London (1870), 61-69.

A review of the genus with key to the species and description of *P. gouldi*, new species.

- Sharpe, R. B.:** [Classification of the Rallidæ.] *Bull. Brit. Orn. Club* (1893), **1**, No. V, 26-28.
Includes the diagnosis of *Poliolimnas*, new genus, type *P. cinereus* Vieillot).
- Sharpe, R. B.:** [New birds from the Sulu Archipelago.] *Bull. Brit. Orn. Club* (1893), **3**, No. XII, 9, 10.
Diagnosis of *Scops sibuense*, *Prioniturus verticalis*, *Dicæum sibuense*, and *Edoliisoma everetti*, new species.
- Sharpe, R. B.:** [On the distribution of the species of the genus *Butorides*.] *Bull. Brit. Orn. Club* (1893), **3**, No. XII, 17, 18.
Notes on *Butorides javanica* and *B. amurensis*; diagnosis of *B. spodiogaster*, new species.
- Sharpe, R. B.:** [On two new owls.] *Bull. Brit. Orn. Club* (1897), **6**, No. XIV, 47; also *Ibis* (1897), VII, **3**, 449.
Ninox everetti, new species, described from Siasi.
- Sharpe, R. B.:** [Notes on the bitterns and herons.] *Bull. Brit. Orn. Club* (1894), **3**, No. XVII, 30-33.
Gives the distribution of the various species of *Ardetta* and calls attention to the name *Ardea manillensis* of Meyen which must be used for the Asiatic race of *A. purpurea*.
- Sharpe, R. B.:** [On *Micropus nehrkorni*.] *Bull. Brit. Orn. Club* (1894), **4**, No. XX, 4, 2.
Sharpe shows that *Micropus nehrkorni* of Blasius is really a *Melaniparus*.
- Sharpe, R. B.:** [Notes on the Muscipidæ.] *Bull. Brit. Orn. Club* (1901), **11**, No. LXXIX, 60.
Siphia enganensis Grant is referred to *S. herioti* Ramsay; *Dendrobiaestes basilanica* Sharpe is said to be without doubt the female of *Muscicapula mindanensis* Blasius and this species should stand as *Muscicapula basilanica* (Sharpe).
- Sharpe, R. B.:** [Notes on the Ardeinæ.] *Bull. Brit. Orn. Club* (1894), **3**, No. XVII, 37-39.
Sharpe accepts the name *Phoyx* for the large purple herons and proposes, among other new generic names, that of *Mesophoyx* for *Herodias intermedia*.
- Sharpe, R. B.:** [List of the species of Ardeidæ.] *Bull. Brit. Orn. Club* (1895), **5**, No. XXXI, 10-13; also *Ibis* (1896), VII, **2**, 253-257.
A list of the species of herons and bitterns as determined for the Catalogue of Birds in the British Museum, volume 26.
- Steere, J. B.:** On the distribution of genera and species of non-migratory land-birds in the Philippines. *Ibis* (1894), VI, **6**, 411-420; also *Auk* (1894), **11**, 232-240.
An elaborate essay in which the author attempts to prove that the law of distribution of non-migratory land-birds of the Philippines may be stated as follows: "The genus is represented by but a single species in a place. Or in more general terms as follows: No two species near enough alike structurally to be adapted to the same conditions will occupy the same area." On this subject see Worcester, *Proc. U. S. Nat. Mus.* (1898), **20**, 567.

Steere, J. B.: The Philippine Islands. *Nature*, Nov. 8 (1888), **39**, 37.

A letter dated Manila, July 2, 1888. The Philippine Islands defined as a zoological province comprising a number of subprovinces, each characterized by representative species of birds and probably of mollusks.

Steere, J. B.: A list of the birds and mammals collected by the Steere Expedition to the Philippines, with localities and with brief preliminary descriptions of supposed new species. *Ann Arbor, Mich.*, July 14 (1890), 1-27.

A list of 367 species with islands on which they were found by the members of this expedition: J. B. Steere, D. C. Worcester, F. S. Bourns, and E. L. Moseley, and with descriptions of the following new species: *Prioniturus luconensis*, *P. mindorensis*, *Cyclopsitta mindanensis*, *Loriculus siquijorensis*, *L. mindorensis*, *L. worcesteri*, *Circus philippinensis*, *Spilornis panayensis*, *Thriponax philippinensis*, *T. mindorensis*, *Chrysocolaptes samarensis*, *Yungipicus basilanicus*, *Y. leytenis*, *Ceyx samarcensis*, *C. mindanensis*, *C. basilanica*, *C. fluminicola*, *C. bournsi*, *C. malamau*, *Actenoides moseleyi*, *Centrococyx mindorensis*, *Penelopides basilanica*, *P. samarensis*, *P. mindorensis*, *Artamides mindorensis*, *A. mindanensis*, *A. panayensis*, *Edolisoma (Graucalus) panayensis*, *Pseudolalage minor*, *Pericrocotus leytenis*, *Hypothymis samarensis*, *Cyanomyias helenæ*, *Setaria samarensis*, *Oriolus samarensis*, *Macronus mindanensis*, *Mizornis nigrocapitatus*, *Ptilocichla* (?) *basilanica*, *Ptilocichla* (?) *mindanensis*, *Ircna ella*, *Poliolophus basilanicus*, *Iole guimarasensis*, *I. mindanensis*, *I. siquijorensis*, *Cittocinclera cebuensis*, *Orthotomus panayensis*, *O. samarensis*, *Zosterops basilanica*, *Philemon philippinensis*, *Dicaeum besti*, *Prionochilus samarensis*, *Cinnyris guimarasensis*, *Corvus samarensis*, and *Sarcophanops samarensis*. Although the descriptions are usually extremely meager and often altogether too short, this is the most important single paper on Philippine birds since Sharpe's report on the Steere collection.

Waterhouse, F. H.: Avium generum index alphabeticus. *Bull. Brit. Orn. Club* (1899), **9**, 1-31.

An index to the genera adopted in the 27 volumes of the Catalogue of the Birds in the British Museum.

Whitehead, J.: Notes on the birds of Palawan. *Ibis* (1893), **VI**, **5**, 38-61, pl. 2.

A list, with notes, of 157 species collected by Whitehead. *Buchanga palawanensis* is described as new, and *Baza leucopais* is the subject of the colored plate.

Whitehead, J.: Field-notes on birds collected in the Philippine Islands in 1893-6. *Ibis* (1899), **VII**, **5**, (part I) 81-111; part II, 210-264; part III, 381-399; part IV, 485-501.

An enumeration of 359 species collected or observed by Whitehead, with notes of considerable interest and importance. Most of the species were previously recorded in the series of articles by Grant.

Whitehead, J.: [On a new pigeon.] *Bull. Brit. Orn. Club* (1897), **6**, No. XLIII, 34; also *Ibis* (1897), **VII**, **3**, 439.

Ptilocolpa nigrorum, new species, described from Negros.

Whitehead, J.: [A new flycatcher.] *Bull. Brit. Orn. Club* (1893), **1**, No. VI, 31.

Diagnosis of *Cryptolopha xanthopygia*, new species, from Palawan.

Whitehead, J.: [On the genus *Dendrophila*.] *Bull. Brit. Orn. Club* (1897), 6, No. XLV, 49; also *Ibis* (1897), VII, 3, 450, 451.

Dendrophila lilacea, new species, described from Samar.

Whitehead, J.: [On a new flycatcher.] *Bull. Brit. Orn. Club* (1897), 6, No. XLIV, 43; also *Ibis* (1897), VII, 3, 446.

Muscicapula nigrorum, new species, described from Negros.

Worcester, D. C.: Contributions to Philippine ornithology. Part II.—Notes on the distribution of Philippine birds. *Proc. U. S. Nat. Mus.* (1898), 20, 567–625, pls. 55–61.

This paper consists of a discussion of the zoölogical relationships of the various island groups based upon the evidence furnished by their birds. The divisions are mainly the same as those advocated by Steere, but Bohol is grouped with Leyte instead of with Cebu. Cebu is separated from the central islands, and Balabac and Palawan with the Calamianes are shown to be more closely related to Borneo than to the rest of the Philippines. The conclusions reached are too extended to be repeated here. Steere's law of distribution is fully discussed and shown to be unwarranted by the evidence. The factors of the origin and distribution of the genera and species of resident Philippine land birds are set forth in considerable detail; the conclusions are too lengthy for repetition. A bibliography concludes the paper. Plate 55 is a map of the Philippine Islands. The remaining plates are diagrammatic.

Worcester, D. C.: On a nesting specimen of *Caprimulgus griseatus* Walden. *Phil. Journ. Sci.* (1907), 2, Sec. A, 275, pl. 1–2.

Nesting of this species in northern Luzon with reproductions of three photographs of the bird and one photograph of its eggs.

Worcester, D. C.: On a nesting place of *Sula sula* (Linnæus) and *Sterna anæstheta* Scopoli. *Phil. Journ. Sci.* (1907), 2, Sec. A, 275–276, pl. 1.

States that these two species probably nest on Didikas Rocks. The plate is from a photograph of these rocks.

Worcester, D. C. and Bourns, F. S.: Contributions to Philippine ornithology. Part I.—A list of the birds known to inhabit the Philippine and Palawan Islands, showing their distribution within the limits at the two groups. *Proc. U. S. Nat. Mus.* (1898), 20, 549–566.

This is a most useful list; the species and islands are arranged in tabular form with indication of the species collected by the Menage Expedition. See also under Bourns and Worcester.

Worcester, D. C.: Preliminary notes on the birds and mammals collected by the Menage scientific expedition to the Philippine Islands. See under Bourns and Worcester.

Worcester, D. C.: A hand-list of the birds of the Philippine Islands. See under McGregor and Worcester.

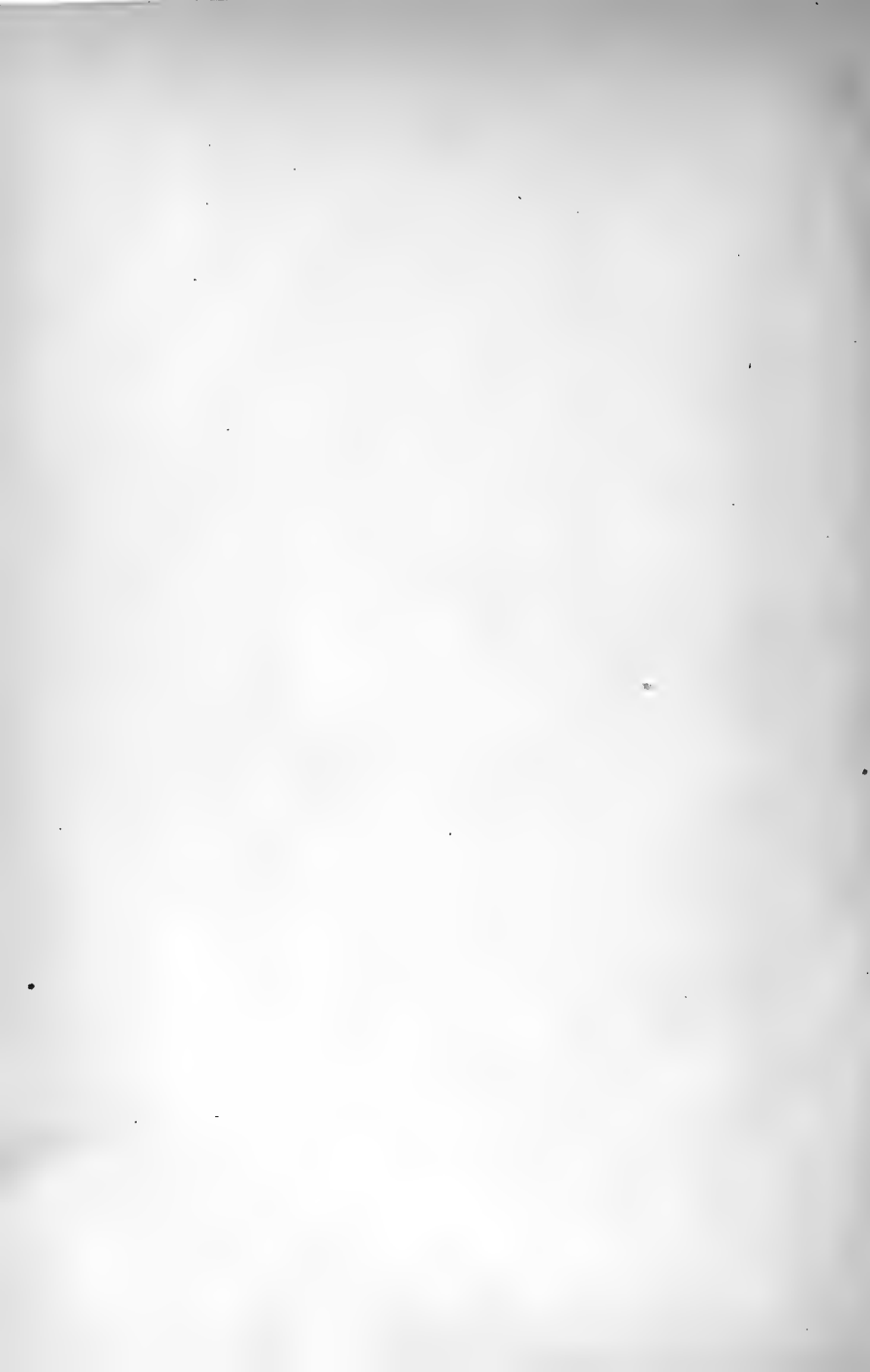

THE BONTOC IGOROT.

Order No. 401.

By A. E. JENKS.

110 pages. 3 maps. 154 photographic plates. 9 figures.

An interesting study; the result of almost a year's residence among the Bontoc Igorots.

Price \$1 United States currency, postpaid.

NEGRITOS OF ZAMBALES.

Order No. 402.

By WILLIAM ALLAN REED.

62 photographic illustrations. 91 pages.

An interesting ethnological study of the pygmy blacks of Zambales.

Price \$0.25, United States currency, postpaid.

THE NABALOI DIALECT.

Order No. 403.

By OTTO SCHBERER.

TOGETHER WITH

THE BATAKS OF PALAWAN.

By EDWARD Y. MILLER.

199 pages. 1 map. 23 full-page photographic plates. 6 figures.

The result of research work among this interesting tribe of primitive people.

Price \$0.25, United States currency, paper, postpaid.

NOTE.

Orders should be sent to the Business Manager, Philippine Journal of Science, Manila, or to any of the below-listed agents. *Please give Order Number.*

FOREIGN AGENTS.

The Macmillan Company, 64-66 Fifth Avenue, New York City, U. S. A.
Messrs. Wm. Wesley & Son, 28, Essex Street, Strand, London, W. C., England.
Mr. Martinus Nijhoff, Nobelstraat 13, The Hague, Holland.
Messrs. Mayer & Müller, Prinz Louis Ferdinandstrasse 2, Berlin, N. W., Germany.
Messrs. Kelley & Walsh, Limited, 32 Raffles Place, Singapore, Straits Settlements.
Messrs. A. M. & J. Ferguson, 19 Baillie Street, Colombo, Ceylon.

CIRCULARS AND DESCRIPTIVE MATTER SENT ON APPLICATION.

Beginning with Volume V, a new section, "Section D, Ethnology, Anthropology, and General Biology," will be added to the Journal. The price for the whole series to subscribers for 1910 will be as heretofore, \$5 United States currency. Single subscriptions to Section D will be \$2 United States currency.

Beginning with 1911, the price of the entire Journal will be increased to \$7 United States currency. Section D will appear as often as material is available.

CONTENTS.

	Page.
GRIFFIN, LAWRENCE E. The Pearl Fishery of Bantayan	149
SEALE, ALVIN. The Successful Transference of Black Bass into the Philippine Islands, with Notes on the Transportation of Live Fish Long Distances	153
SCHULTZE, W. Contributions to the Lepidopterous Fauna of the Phil- ippines	161
MOSER, J. Neue Coleoptera Lamellicornia Von Den Philippinen	183
BEAN, ROBERT BENNET. Filipino Ears, II: Ears From Malecon Morgue	191
MCGREGOR, RICHARD C. Additional Notes on Birds from Northern Mindanao, Philippine Islands	197
MCGREGOR, RICHARD C. Note on the Migration of the Tic-Wee Buzzard in the Philippine Islands	199
MCGREGOR, RICHARD C. Philippine Ornithological Literature III	203

The "Philippine Journal of Science" is issued as follows:

Section A, Chemical and Geological Sciences and the Industries, \$2 United States currency per year.

Section B, Medical Sciences, \$3 United States currency per year.

Section C, Botany, \$2 United States currency per year.

Section D, Ethnology, Anthropology, and General Biology, \$2 United States currency per year.

The entire "Journal," \$5 United States currency for Volumes II, III, IV, and V. Thereafter, \$7 United States currency per year.

Authors receive 100 copies of their papers free.

Subscriptions should be sent to the Business Manager, Philippine Journal of Science, Bureau of Science, Manila, P. I., or to any of the agents listed below. Please give order number.

FOREIGN AGENTS.

The Macmillan Company, 64-66 Fifth Avenue, New York City, U. S. A.

Messrs. Wm. Wesley & Son, 28 Essex Street, Strand, London, W. C., England.

Mr. Martinus Nijhoff, Nobelstraat 18, The Hague, Holland.

Messrs. Mayer & Muller, Prinz Louis Ferdinandstrasse 2, Berlin, N. W., Germany.

Messrs. Kelley & Walsh, Limited, 32 Raffles Place, Singapore, Straits Settlements.

Messrs. A. M. & J. Ferguson, 19 Baillie Street, Colombo, Ceylon.

A limited number of unbound copies of previous volumes are available, which may be secured from the Business Manager, Philippine Journal of Science, Manila, P. I., at the following rates: Volume I, 1906 (not divided into sections), \$10 United States currency; Supplement to Volume I, \$3.50 United States currency; Volume I (without supplement), \$6.50 United States currency; all later volumes at current subscription prices.

Vol. V. OCTOBER, 1910 No. 4

THE PHILIPPINE JOURNAL OF SCIENCE

EDITED BY

PAUL C. FREER, M. D., PH. D.

WITH THE COÖPERATION OF

DEAN C. WORCESTER, A. B.; ROBERT BENNETT BEAN, M. D.
MERTON L. MILLER, PH. D.; CHARLES S. BANKS, M. S.
ALVIN SEALE, A. B.; LAWRENCE E. GRIFFIN, PH. D.
RICHARD C. MCGREGOR, A. B.; NELLIE LOUISE COOK, B. L., M. A.

PUBLISHED BY

THE BUREAU OF SCIENCE

OF THE

GOVERNMENT OF THE PHILIPPINE ISLANDS

D. ETHNOLOGY, ANTHROPOLOGY, AND GENERAL
BIOLOGY

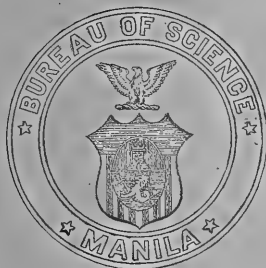

MANILA
BUREAU OF PRINTING
1910

Order No. 405.

STUDIES IN MORO HISTORY, LAW, AND RELIGION.

By NAJEEB M. SALEEBY.

107 pages. 16 illustrations. 5 diagrams.

A treatise on the history and customs of the Moro People.

Price \$0.25, United States currency, postpaid.

Order No. 406.

THE HISTORY OF SULU.

By NAJEEB M. SALEEBY.

275 pages.

A complete History of the Moro People in Sulu, with maps and many translations from the original documents.

Price \$0.75, United States currency, postpaid.

Order No. 410.

MINDANAO.

THE SUBANUNS OF SINDANGAN BAY.

By EMERSON B. CHRISTIE.

122 pages.

Profusely illustrated.

This, together with the History of Sulu and the Studies in Moro History, Law and Religion, is one of an authentic and valuable set of works on the origin, history and customs of these tribes, who are among the most interesting peoples of the world.

Price \$1.25, United States currency, postpaid.

NOTE.

Orders should be sent to the Business Manager, Philippine Journal of Science, Manila, or to any of the below-listed agents. *Please give Order Number.*

FOREIGN AGENTS.

The Macmillan Company, 64-66 Fifth Avenue, New York City, U. S. A.
Messrs. Wm. Wesley & Son, 28 Essex Street, Strand, London, W. C., England.
Mr. Martinus Nijhoff, Nobelstraat 18, The Hague, Holland.
Messrs. Mayer & Muller, Prinz Louis Ferdinandstrasse 2, Berlin, N. W., Germany.
Messrs. Kelley & Walsh, Limited, 32 Raffles Place, Singapore, Straits Settlements.
Messrs. A. M. & J. Ferguson, 19 Baillie Street, Colombo, Ceylon.

CIRCULARS AND DESCRIPTIVE MATTER SENT ON APPLICATION.

THE PHILIPPINE
JOURNAL OF SCIENCE

D. ETHNOLOGY, ANTHROPOLOGY, AND
GENERAL BIOLOGY

VOL. V

OCTOBER, 1910

No. 4

✓ A LIST OF SNAKES FROM THE ISLAND OF POLILLO, P. I.,
WITH DESCRIPTIONS OF A NEW GENUS AND
TWO NEW SPECIES.¹

By LAWRENCE E. GRIFFIN.

(Associate Professor of Zoology in the Philippine Medical School.)

Python reticulatus (Schneider), Nos. 811, 824, 825, 826.

Four specimens, from 0.9 to 2.5 meters in length.

Natrix spilogaster Boie, No. 808.

Cyclocorus lineatus (Reinhardt), Nos. 809, 810.

HAPLONODON² gen. nov.

Maxillary teeth in two series, separated by a short interspace; the posterior teeth of each series largest, 14 or 15 in all. Anterior end of maxilla bent slightly inward.

Anterior mandibular teeth enlarging to the fourth, followed by smaller teeth of equal size. Head distinct from neck. Eye moderate, pupil vertically elliptic. Body slender, slightly compressed; tail long. Scales smooth, in 17 longitudinal rows, without apical pits; subcaudals in two rows.

¹ Contribution from the Biological Laboratory, Bureau of Science, Manila, P. I.

² ἀπλός, single; νωδός, toothless.

Haplonodon philippinensis sp. nov. [Plate I.]

The anterior end of the maxillary is curved inward but slightly. The maxillary teeth are arranged in three series; the eight or nine anterior increase in size from the first to the last; after a short interspace come three small teeth, followed by three which are much larger, laterally compressed, and almost fang-like. There is no interspace between the last tooth of the middle series and the first one of the posterior series. The four anterior mandibular teeth increase in size to the fourth and are considerably larger than the remaining ones, which are all of about equal size.



Maxilla of *Haplonodon philippinensis*. $\times 6$.

Eye moderate, pupil vertically elliptic. Body slender, slightly compressed; tail long; a well-defined keel along each side of the belly and tail; subcaudals in two rows. Scales smooth, arranged in longitudinal rows, without apical pits; the vertebral and lateral rows are not noticeably larger than the others; scales in 17 rows; ventrals 203; anal entire; subcaudals 95+ (the tip of the tail is broken off). Rostral considerably broader than deep, its upper point entering deeply between the internasals, the portion visible from above being equal to one-third of its distance from the frontal; nostril quite large, in a single concave nasal; internasals much shorter and narrower than praefrontals; frontal almost as broad as long, twice as wide as the supraoculars, measuring each on the line joining the middle of the eyes; much shorter than the parietals, a little longer than its distance from the point of the rostral; loreal about three times as long as broad, entering the eye; one small praecular above the loreal, nearly reaching the frontal; two postoculars; temporals 2+2; nine upper labials, fourth and fifth entering the eye, seventh and eighth largest and of equal size; five lower labials in contact with the anterior chin-shields, which are longer and broader than the posterior.

The dorsal surface of the body and tail are crossed by 79 dark brown bands, separated by narrow bands of white finely dotted with brown. The edges of the latter bands are pure white, which outlines the darker and broader bands very distinctly and prettily. In the dorsal portions of the lighter bands the brown dots are often confluent, producing a grayish brown color. The dots are finer and more separated toward the ventral surface. The ventral portions of most of the brown bands are narrowly separated from the dorsal parts by fine white lines. A large brown spot lies upon each lateral end of most of the ventral scales; the ventral surface of the head and body is white. Brown dots become increasingly numerous on the lower surface as the anus is approached; the lower surface of the tail is closely covered with brown dots. The upper surface

of the head is very dark dull brown, almost black, adorned by a reticulate pattern of fine white lines. The centers and lower edges of the upper labial scales are white, their adjoining edges brown. All the scales are extremely smooth and glossy. The colors did not change upon preservation of the specimen in formalin.

This snake seems to be very rare. The natives to whom it was shown had never seen it before, and none of them knew a native name for it.

List of specimens of Haplonodon philippinensis sp. nov.

Museum.	Number.	Sex.	Locality.	When collected.	Collector.	Scale rows.	Ventrals.	Anal.	Subcaudals.	Temporals.	Supralabials.	Total length.	Length of tail.
Bureau of Science.	883	Male	Polillo.	Oct. 1909.	C. Cananizado.	17	203	1	95+	2+2	9	mm. 0.800	mm. 0.196

This species combines characters of both Ophites (*Lycodon*) and *Dinodon*; and might easily represent an intermediate genus. It differs from *Ophites* in the lesser inward curvature of the anterior end of the maxilla, the greater number of anterior maxillary teeth, the small number of middle maxillary teeth, abruptly succeeded by three greatly enlarged posterior teeth, and by the gradual and lesser enlargement of the four anterior mandibular teeth, which are followed by small teeth without an interspace. It differs from *Dinodon* in having only a single interspace between the maxillary teeth, that between the last enlarged anterior tooth and the first small middle tooth. The tail is also longer in proportion to the body than in any species of *Dinodon*. It differs from both genera in the absence of apical pits.

Elaphe erythrura (Dumeril & Bibron), No. 804.

Dendrophis pictus (Gmelin), Nos. 773, 774, 775, 776, 790, 791, 792.

These snakes are colored a uniform dark brown above. The lateral rows of scales and the ventral surface are a uniform light blue. A narrow black line runs along the outer edges of the ventrals. When the scales of the dorsal surface are rubbed off, the underlying skin is a uniform rich, dark blue. These specimens are colored almost exactly like *Dendrelaphis cæruleatus*.

The natives of Polillo call all *Dendrophis* and *Dendrelaphis*, and probably other similar snakes, *calapiin matulin*. *Calapiin* means "poisonous snake," *matulin*, "quick."

Dendrelaphis cæruleatus Griffin, Nos. 760, 761, 762.

Hurria rhynchops (Schneider), No. 788.

Boiga cynodon (Boie), No. 803.

Boiga angulata (Peters), No. 789.

The specimen does not agree exactly in all respects with the description given by Boulenger in the Catalogue of the Snakes in the British Museum, but it probably is one of this species. The stomach of this specimen contains a large lizard (*Calotes*).

Boiga dendrophila (Boie), Nos. 805, 806.

Psammodynastes pulverulentus (Boie), No. 812.

Dryophis prasinus Boie, Nos. 796-802.

Chrysopelea ornata (Shaw), Nos. 777-787.

Hemibungarus sp. No. 807. Said to be the young of *H. calligaster* (Wiegmann).

Trimerisurus halieus³ sp. nov.

Subcaudals in two rows. Tail but slightly prehensile. Scales between eyes smooth, gular scales smooth. Upper surface of head flat and depressed, snout with distinct canthus. First pair of lower labials in contact behind the symphysial. Scales in 21 rows; ventrals 170-182, anal entire, subcaudals 52-59; 10-13 scales between the supraoculars. Supraocular narrow, often partially or completely broken up. Length of eye not more than half the distance from the eye to the tip of the snout, and in most specimens less. Dimensions of rostral equal, or the width slightly more than the depth. Nasal semidivided; internasals separated by one, two or three scales; upper head scales of moderate size, flat, subimbricate; two or three postoculars; a subocular, in contact with the third and fourth labials, separated from the fifth and sixth (and sometimes from the fourth) by one series of scales. 9-11 upper labials, usually 10; the fifth to the last small; the first not fused with the nasal; the second forming the anterior border of the loreal pit; the third the largest, touching the subocular; the fourth also large, its upper portion occasionally separated as a distinct scale; temporal scales smooth and large, scales of body distinctly but not strongly keeled, lateral rows and scales of tail smooth.

The back and sides are dark blue to brownish-purple, either uniform or crossed by irregular dull, reddish-brown bars. The ventral surface is a light shade of the body color, generally bluish. The posterior border of each ventral scale is more lightly colored, thus forming an alternating series of light and dark transverse bands which correspond to the ventral scales. There are no lateral stripes as in *T. gramineus* and *T. flavomaculatus*. The tail is colored like the body, never red.

³ ἅλιευσ, a fisherman.

List of specimens of Trimerisurus haliens sp. nov.

Museum.	Number.	Sex.	Locality.	When collected.	Collector.	Total length.	Length of tail.	Scale rows.	Anals.	Ventrials.	Subcaudals.	Scalcs between	Number of
						mm.	mm.					supracaudals.	
Bureau of Science.	763	Female.	Polillo.	Oct. 1, 1909.	Canonizado.	0.810	0.110	21	1	181	55	10	10
Do	764	do	do	do	do	.830	.120	21	1	181	59	13	11
Do	765	do	do	do	do	.970	.140	21	1	175	54	10	10
Do	766	do	do	do	do	.730	.090	21	1	177	57	11	10
Do	767	do	do	do	do	.650	.090	21	1	178	52	11	11
Do	768	do	do	do	do	1.100	.140	21	1	181	58	13	10
Do	769	do	do	do	do	.900	.110	21	1	181	53	11	10
Do	770	Male.	do	do	do	.740	.100	21	1	170	58	10	10
Do	771	Female.	do	do	do	.820	.110	21	1	182	54	10	10
Do	772	(?)	do	do	do	1.040	.130	21	1	179	55	12	10

The specimens were all collected along the banks of streams or in damp localities.

This snake seems to leave the ground very rarely. When the natives of the islands go at night along the streams to catch mudfish by torchlight, the snakes are commonly seen near the edge of the water, and the fishermen say that they are there for the same purpose as themselves, and for this reason call the snake *mánda-dalág*, which, literally translated, means "the fisher of the *dalág* (or mud-fish)." Sr. Cesario Canonizado captured one specimen which had buried most of its body in the sand close to the water's edge. The place where the snake was lying was partly covered with water, while a few inches away was deeper water in which numerous small fish were swimming about for which the snake appeared to be lying in wait.

On another occasion Canonizado noticed a commotion in the rice near the edge of a paddy. The disturbance was caused by a struggle between a large *Varanus* and a snake of this species. On the approach of Canonizado the *Varanus* ran away, so he could not see which was the attacking party. The snake was easily lassoed, for this species seems to be much more inclined to fight than to retreat from men. When the fishermen, in their night fishing, walk along the water's edge holding their torches ahead of them the snakes frequently strike at the lights, and occasionally the fishermen are bitten with fatal results.

The stomach of No. 764 contained an entire frog. In the intestine of No. 763 were found a few scales, probably of a fish. The intestine of No. 765 contained a large ball of hair of a rat.

ILLUSTRATIONS.

PLATE I. *Haplonodon philippinensis* Griffin, sp. nov., natural size.



T. Espinosa, del.

PLATE I.



BIRDS FROM THE COAST OF NORTHERN LUZON AND
FROM THE ISLANDS OF SABTAN AND DALUPIRI.

By RICHARD C. MCGREGOR.

(From the Ornithological Section, Biological Laboratory, Bureau of Science,
Manila, P. I.)

In August, 1909, through the courtesy of Dean C. Worcester, Secretary of the Interior, I was enabled to visit Sabtan Island in the Batanes, Dalupiri Island in the Babuyan, and several localities on the coast of northern Luzon. Although but a short time, usually one hour to one day, was spent in each locality, some interesting birds were secured, and it seems worth while to record the species noted.

Tagudin, August 14.—Tagudin is situated on the coast, in the southern part of Ilocos Sur. A small colony of the starling, *Ætheopsar cristatellus* (Linnæus), was found established here and the large-nosed shrike, *Cephalophoneus nasutus* (Scopoli) was abundant. Three night-jars, *Caprimulgus griseatus* Walden, were flushed from among small bushes at 200 meters from the beach.

Sabant Island, August 16.—Thorough collections were made on Batan Island in 1907,¹ and it is improbable that Sabtan will yield any additional species. The following were seen during a few hours spent in the hills back of San Vicente, Sabtan: *Munia jagori* Martens, *Anthus rufulus* Vieillot, *Zosterops batanis* McGregor, and *Micropus pacificus* (Latham).

Dalupiri Island, August 19.—Dalupiri is the one island of the Babuyan from which we have had no zoological nor botanical collections. From the sea this island presented a low, even outline with but a slight elevation in the central part, and the vegetation appeared to consist of grass and small shrubs, thus resembling Fuga and contrasting strongly with Calayan and Camiguin. Upon landing and working inland a short distance there was discovered a considerable growth of small trees, but the soil was very thin and scarcely covered the coral-limestone. It is not to be expected that this island sustains so varied or interesting a fauna as does either Calayan or Camiguin. The birds identified on Dalupiri

¹ *This Journal*, Sec. A (1907), 2, 337.

belong to the following species: *Demigretta sacra* (Gmelin), *Centropus viridis* (Scopoli), *Hypsipetes fugensis* Grant, *Oriolus acrorhynchus* Vigors, and *Corone philippina* (Bonaparte).

Abúlug River, August 21 to 26.—The Abúlug River enters the sea on the northern coast of Luzon at a distance of some twenty-five kilometers from the mouth of the Rio Grande de Cagayan. While Mr. Worcester and his party went to the headwaters of the river for the purpose of visiting a tribe of mountain people, I was left with my assistants at a camp a few kilometers from the coast. This part of the valley is covered with thick, lowland jungle, and the difficulties of travel by land are increased by masses of débris brought down by the yearly floods which cover large areas with water from two to five meters in depth. The most interesting birds secured in the vicinity of the camp were *Halcyon lindsayi*, male and female, and a specimen of *Hyloterpe albiventris*. In the following list an asterisk indicates that specimens were collected:

BIRDS FROM ABÚLUG RIVER CAMP.

<i>Osmotreron axillaris</i> (Bp.).*	<i>Iole gularis</i> (Pucheran).*
<i>Phapitreron leucotis</i> (Temm.).*	<i>Pycnonotus goiavier</i> (Scop.).
<i>Leucotreron leclancheri</i> (Bp.).*	<i>Kittacincla luzoniensis</i> (Kittlitz).
<i>Macropygia tenuirostris</i> Bp.*	<i>Orthotomus chloronotus</i> Grant.*
<i>Streptopelia dussumieri</i> (Temm.).*	<i>Artamus leucorhynchus</i> (Linn.).
<i>Bubulcus coromandus</i> (Bodd.).	<i>Hyloterpe albiventris</i> Grant.*
<i>Eurystomus orientalis</i> (Linn.).	<i>Dicaeum pygmaeum</i> (Kittlitz).*
<i>Halcyon lindsayi</i> (Vig.).*	<i>Cinnyris henkei</i> Meyer.*
<i>Collocalia troglodytes</i> Gray.*	<i>Munia cabanisi</i> Sharpe.*
<i>Yungipicus validirostris</i> Blyth.*	<i>Oriolus acrorhynchus</i> Vig.
<i>Cyornis philippinensis</i> Sharpe.	<i>Corone philippina</i> (Bp.).
<i>Rhipidura cyaniceps</i> (Cass.).	

Claveria, August 27.—Claveria is a small town on the northern coast of Luzon, some thirty-five kilometers northwest of the mouth of the Abúlug River. There is considerable forest in the vicinity of this town, where large hornbills (*Hydrocorax*) were heard calling. The only birds collected at Claveria were *Artamides striatus* (Boddaert) and *Anthreptes griseigularis* Tweeddale.

Northeastern coast of Luzon, August 28 and 29.—Between Cape Engaño and Palanan several brief landings were made at places for which no names appear on charts. There was not sufficient time to get into the forest at any of these points and very little of interest was found near the beach. A pair of *Orthorhamphus magnirostris* (Vieillot) and several examples of *Ardea sumatrana* Raffles were seen at our fifth landing.

Palanan, August 30.—One male specimen of *Charadius fulvus* Gmelin was killed at Palanan.

Casiguran, August 31.—Two species, *Hirundo striolata* (Boie) and *Uroloncha everetti* (Tweeddale), were abundant at Casiguran and specimens of them were collected.

Baler, August 31 and September 1.—At Baler species of *Dasylophus*, *Dicrurus*, *Kittacincla*, and *Iole* were abundant in small trees and thickets near the beach, while hornbills, *Hydrocorax* and *Penelopides*, seemed to be abundant on a heavily wooded hillside. Specimens collected at Baler belong to the following species:

<i>Bolbopsittacus lunulatus</i> (Scop.).	<i>Yungipicus validirostris</i> (Blyth).
<i>Loriculus philippensis</i> (P. L. S. Müll.).	<i>Artamides striatus</i> (Bodd.).
	<i>Iole gularis</i> (Pucheran).
<i>Collocalia fuciphaga</i> (Thunb.).	<i>Rhabdornis mystacalis</i> (Temm.).
	<i>Anthreptes griseigularis</i> Tweed.

V
UEBER CHRYSOMELIDEN UND COCCINELLIDEN DER
PHILIPPINEN.

VON J. WEISE.
(Berlin, Germany.)

Herr Charles S. Banks sandte mir eine Anzahl von Insekten des Bureau of Science in Manila aus den oben genannten Familien zur Durchsicht ein. Sie geben Anlass zu folgenden Bemerkungen und Beschreibungen.

I. CHRYSOMELIDEN.

1. *Cleorina philippinensis* Jac., Ann. Soc. Ent. Belg. (1898) 42, 364.

Es ist fraglich, ob sich diese Art wirklich von *C. morosa* Lef., Cat. 144, spezifisch unterscheidet. Die echte *philippinensis* entfernt sich von anderen Arten z. B. *Cleorina aeneomicans* Baly durch die abgekürzte Punktreihe der Flügeldecken, welche nicht neben der Naht, sondern zwischen der *ersten* und *zweiten* ganzen Punktreihe liegt. Die Hinterbrust ist dicht und grob punktiert, der Bauch fein chagriniert, die Mitte des ersten Segmentes runzelig punktiert. Ungenau ist die Angabe Lefèvèrès in der Gattungsdiagnose: „die 5 letzten Fühlerglieder wenig verdickt;“ es sind vielmehr nur die Glieder 2 bis 4 dünner als die übrigen. (5489, *C. S. Banks.*)

2. *Aulacophora uniformis* Chap., Bull. Ann. Soc. Ent. Belg. (1876) 19, 99.

Die vorliegenden Stücke sind 7 bis 9 mm. lang (Chapius gibt 11 mm. an) und haben ungefähr dieselbe Grösse wie *rosea* Fabr. und *positica* Chap. Das letzte Fühlerglied kann rötlichgelb oder schwarz sein; letztere Farbe dehnt sich zuweilen auch über das vorletzte Glied aus.

3. *Antipha punctata* All., Bull. Ann. Soc. Ent. Belg. (1889) 33, 107.

Der Thorax ist völlig oder fast glatt und hat nur wenige Punkte über den Vorderecken. Die Flügeldecken sind mit nicht besonders starken, teilweise gereihten Punkten besetzt, die im letzten Drittel schwächer werden, eine Basalbeule wird durch einen leichten Quereindruck angedeutet. Jede Flügeldecke hat zwei schwarze Querbinden, eine an der Basis, die andere hinter der Mitte. Die erste ist gemeinschaftlich, ziemlich von gleicher Breite, oder am Seitenrande erweitert, sie nimmt

ungefähr ein Sechstel der Länge ein. Die zweite berührt weder Naht noch Seitenrand, ist gewöhnlich in der Mitte eingeschnürt und jederseits etwas nach hinten ausgezogen; sie scheint aus zwei Flecken entstanden zu sein.

Diese Zeichnung ist sehr variabel. Öfter ist die vordere Binde auf einen kleinen Fleck am Seitenrande, dicht hinter der Schulterbeule beschränkt und die innere Hälfte der zweiten Binde ist erloschen; jedenfalls kommen auch Stücke mit einfarbig rötlich gelbbraunen Flügeldecken vor. (295, *C. S. Banks*; 6368, *E. D. Merrill*.)

4. *Cynorta cavifrons* Duviv., Stett. Ent. Zeit. (1885) 46, 247.

Grösse und Farbe scheinen bei dieser Art zu variieren. Von den beiden vorliegenden Exemplaren (δ), ist das eine 4.5 mm. lang, das andere 5.5, der Bauch bei dem kleineren einfarbig bläulich schwarz bei dem grösseren sind die beiden ersten Ringe und der Mittelzipfel des letzten rötlich gelb. (5344, *C. S. Banks*.)

5. *Cynorta citrina* Jac., Ann. Soc. Ent. Belg. (1894) 38, 190.

Die Exemplare sind 6–6.5 mm. lang. Wenn Allard die Bildung der vorderen Gelenkhöhlen und die unbewehrten Schienen bei seiner Gattung *Brachita*, Ann. Soc. Ent. Belg. 1889, C. r. 103, richtig beobachtet hat, so gehört diese nicht zu *Cynorta*, obwohl man aus den sonstigen Angaben, darauf schliesen dürfte. Die folgende Art, von der nur 1 ♀ vorliegt, scheint ebenfalls einfache Schienen zu haben. (6408, *H. M. Curran*; 12950, *E. D. Merrill*.)

6. *Cynorta longicornis* sp. nov.

Elongata, citrina, antennis (basi excepta) tibiis tarsisque nigricantibus, macula verticis apiceque elytrorum fuscis. Prothorace quadrifoveolato, obsolete punctulato, elytris sericeo-micantibus crebre subtiliter punctatis, obsolete costulatis. Long. 9 mm.

Luzon, Manila, P. I. (*Charles S. Banks*, collector).

Type ♀ No. 5308 in der Entomologischen Sammlung des Bureau of Science, Manila, P. I.

Schlank gebaut, auf dem Rücken abgeflacht, mit auffällig langen Fühlern und Beinen, die beide ungefähr so lang wie der Körper sind. Letzterer ist citronengelb, weniger lebhaft als in *citrina* gefärbt, Kopf und Thorax glänzend, Flügeldecken etwas seidenschimmernd. Fühler schwärzlich, die beiden ersten Glieder, namentlich unterseits, rötlich gelbbraun, Schienen und Tarsen ebenfalls schwärzlich, die Oberseite des vorletzten Gliedes der Maxillartaster, ein kleiner Längsfleck des Scheitels und die äusserste Spitze der Flügeldecken angedunkelt. Augen stark gewölbt, die Fühler auf einem grossen Höcker der Stirn eingefügt, der oben durch eine feine Längsrinne halbiert ist. Kopfschild sehr lang

dreieckig, Nasenkiel und Vorderrand wulstartig erhöht, Oberlippe sehr gröss, Mandibeln an der Spitze pechscharz. Thorax etwas länger als breit, von der Basis bis vor die Mitte schwach erweitert, davor verengt und die Vorderecken nach aussen vortretend, die Scheibe ganz verloschen punktuert, mit vier schwachen Gruben, zwei kleinen, dicht nebeneinander, hinter dem Vorderrande, die beiden anderen dahinter, gross, quer. Flügeldecken sehr fein, doch deutlich punktiert, mit zahlreichen verloschenen Längsvertiefungen, welche durch sehr feine und niedrige Rippen getrennt werden.

Die in der Färbung ähnliche *Brachita terminata* All. lässt sich ohne Weiteres durch den Thorax unterscheiden, welcher doppelt so breit als lang angegeben ist.

7. *Cynorta quadriplagiata* sp. nov.

Elongata, citrina, nitida, postpectore, abdomine elytrisque nigris, his in singulo maculis duabus magnis citrinis, prima subbasali, subquadrata, secunda oblonga. Long. 6–6.5 mm.

CALAYAN ISLAND, P. I. (*R. C. McGregor*, collector).

Type No. 638 in der Entomologischen Sammlung des Bureau of Science, Manila, P. I.

Leuchtend citronengelb, die Hinterbrust, der Bauch, ein Saum um jede Flügeldecke und eine gemeinschaftliche Querbinde der letzteren tief schwarz. Von der gelben Farbe bleiben auf jeder Flügeldecke zwei grosse Makeln übrig. Die erste ist quadratisch, mit verrundeten Ecken, reicht nahe an den Vorder-, Seiten- und Nahtrand und endet in kaum ein drittel der Länge. Die zweite ist ungefähr doppelt so lang als breit, beginnt schräg etwas vor der Mitte und endet, leicht zugespitzt, vor der Spitze. Sie liegt der Naht näher als der Makel 1 und dem Seiten- und Hinterrande. Die Spitze der Mandibeln ist pechscharz. Fühler etwas kürzer als der Körper, normal gebaut, Glied 4 etwa so lang als die beiden vorhergehenden zusammen. Thorax breiter als lang, von der Basis bis weit vor die Mitte allmählig erweitert, nahe den Vorderecken gerundet verengt, die Scheibe grösstenteils von einem glatten, weiten Quereindrucke eingenommen, neben dem die Seiten und der gewölbte, ziemlich grosse Raum über den Vorderecken dicht und fein punktiert sind. Schildchen vorn rotbraun, hinten schwarz. Flügeldecken ziemlich dicht, fein und flach punktiert.

Die Beschreibung ist nach dem ♀ entworfen, das ♂ dürfte eine Auszeichnung auf dem Kopfschilde haben.

8. *Monolepta bifasciata* Hornst.

Diese Art ist über die Sunda Inseln und Philippinen verbreitet und von Manila durch Boheman als *rubrosignata* beschrieben worden. Das letzte Fühlerglied, der Anus und das Pygidium sind dunkel gefärbt, die

Basalbinde der Flügeldecken ist innen erweitert und an der Naht beinahe doppelt so breit als an der Schulter. Die Übersicht der Art ist folgende:

Chrysomela bifasciata Hornst., Schrift. naturf. Freunde, Berlin, (1788) 3. Java.
Galleruca bifasciata Fabr., Ent. Syst. (1792) 1, 2, 27; Jac., Notes Leyd. Mus., (1884) 53. (*Monolepta*) Sumatra, Java.

Crioceria 4-notata Fabr., Syst. Eleuth., (1801) 1, 460. Sumatra.

Galeruca 4-notata Oliv., Entom. (1808) 6, 665, t. 5, fig. 90. Java.

Monolepta rubrosignata Bohem., Res. Eugen. (1859) 182. Manila.

9. *Phyllotreta serricornis* Duviv.

Diese Art kann nicht bei der Gattung *Phyllotreta* bleiben, sondern gehört zu *Luperomorpha* Ws. An den Fühlern sind die Glieder 2 und 3 beim ♂ sehr kurz, 2 kugelig, 3 quer und bedeutend kürzer als 2; beim ♀ sind sie länger, 2 kugelig, wenig grösser als beim ♂, 3 schmäler und merklich länger als 2, die folgenden Glieder sind verdickt, beim ♂ bis zum zehnten Gliede gesägt. Das vierte Glied ist so lang wie Glied 2 und 3 zusammen (♀), oder wie die drei vorhergehenden Glieder zusammen (♂). Der Thorax hat eine verloschene Quervertiefung in der Mitte, die Seiten sind fast gradlinig und parallel und treten an der Borstenpore in den Vorderecken nach aussen vor. Der Enddorn der Hinterschienen steht ziemlich in der Mitte und ist grade nach hinten gerichtet, der Metatarsus endlich hat eine schmale, völlig glatte Basis.

10. *Erystus banksi* sp. nov.

Subrotundatus, convexus, pallide testaceo-flavus, nitidus, prothorace sublaevis, basi rotundatim angustato, elytris subtiliter punctatis, protecto laterali lato, paullo fortius punctato a dorso stria punctata sat profunda separato. Long. 5-5.5 mm.

Luzon, Province of Rizal, Montalban Gorge, P. I. (*Charles S. Banks*, collector.)

Type No. 5310 in der Entomologischen Sammlung des Bureau of Science, Manila, P. I.

An dem einfarbig blass bräunlich-gelben, oberseits eine Spur durchscheinenden Körper und den verworren punktierten Flügeldecken, auf denen weder vertiefte Längsreihen noch gewölbte Zwischenstreifen zu bemerken sind, von den bis jetzt bekannten vier Arten zu unterscheiden, von *podagroides* und *villicus* Ws. ausserdem durch die gerundeten Hinterecken des Thorax.

Gerundet, etwas länger als breit, gleichmässig, aber nicht besonders stark gewölbt. Stirnhöcker verloschen umgrenzt oder kaum angedeutet. Die Fühler reichen ziemlich bis zur Mitte der Flügeldecken, Glied 2 ist das kürzeste, 3 länger, aber nicht ganz so lang als 4. Thorax kurz, dreimal so breit wie lang, die Seiten stark gerundet und mit den Hinterecken in einer Flucht abgerundet. Es tritt jedoch weiter nach innen ein kleiner Winkel vor, welcher die eigentlichen Hinterecken andeutet.

In diesen ist die Thoraxbasis viel schmaler als der Vorderrand, und über ihnen ist der Basalrand der Flügeldecken in leichtem Bogen ausgerandet. Die Flügeldecken sind scheinbar ganz verworren fein und flach punktiert, die Punkte von einem dunkel durchscheinenden Kreise umgeben; bei genauer Betrachtung bemerkt man aber dass die Punkte zu unregelmässigen Doppelreihen geordnet sind. Die Scheibe ist aussen durch einen starken Punkstreifen vom Seitendache getrennt. Dieses erinnert durchaus an das Seitendach der Cassiden, ist in der inneren Hälfte fast glatt, in der äusseren unregelmässig punktiert.

11. *Agonia banksi* sp. nov.

Elongata, parum convexa, fulva, nitida, antennis subfiliformibus, nigris, articulo primo rufescente, elytris fortiter punctatis, bicarinatis, apice leviter singulatum-rotundatis, vitta suturali et laterali, antice abbreviatis, postice late conjunctis abdominisque segmentis duobus ultimis nigris. Long. 3.5–3.8 mm.

Luzon, Manila, P. I. (*Charles S. Banks*, collector).

Type No. 5346 in der Entomologischen Sammlung des Bureau of Science, Manila, P. I.

Ähnlich gebaut, aber bedeutend kleiner als *Ag. vandepolli* Gestro und durch die Spitzenbildung der Flügeldecken leicht von dieser und den anderen ähnlichen Arten zu unterscheiden. Die Flügeldecken sind hinten nicht gemeinschaftlich, sondern einzeln abgerundet, denn sie haben an der Naht einen schwachen dreieckigen Ausschnitt in welchem die Nahtcke eine Spur vorgezogen ist. Der Thorax ist breiter als lang, an den Seiten sanft gerundet, oben glatt, eine Reihe hinter dem Vorderende und eine kurze Schrägreihe jederseits dahinter sind aus starken Punkten gebildet, vier grosse, sparsam punktierte Gruben befinden sich vor der Basis. Die Punkte der Flügeldecken sind sehr gross und tief; die schwarze Nahtbinde ist schmal, vorn auf die Kante selbst beschränkt, dann schwach erweitert, die Seitenbinden fangen vorn ebenfalls schmal an und verbreitern sich so, das sie in zwei drittel Länge, von wo aus die ganze Spitze schwarz gefärbt ist, die äussere Rippe berühren. Die Binden beginnen in ein drittel Länge.

12. *Agonia manilensis* sp. nov.

Elongata, parum convexa, pallide fulva, antennis (articulo primo ferrugineo excepto) maculaque apicali elytrorum nigris, tarsis segmento ultimo ventrali infuscatis, prothorace sublaevi, foveis quator ante basin lineaque sub apicali parce punctatis, elytris bicostatis. Long. 4–4.3 mm.

Luzon, Manila, P. I. (*Charles S. Banks*, collector).

Type No. 2621 in der Entomologischen Sammlung des Bureau of Science, Manila, P. I.

Breiter gebaut als die vorige, mit kleineren Punkten in den Reihen

der Flügeldecken, letztere hinten gemeinschaftlich abgerundet und am Rande daselbst deutlicher gekerbt, der Thorax sparsamer punktiert, die Fühler etwas kürzer, aber in den fünf letzten Gliedern stärker, in der Spitze der Flügeldecken endlich nur eine aussen verengte schwarze Quermakel, welche ungefähr das letzte Fünftel einnimmt. Der Thorax ist glatt, hinter dem Vorderrande mit einer weitläufigen starken Punktreihe, dahinter folgen jederseits 2 Punkte, dann die vier Gruben vor der Basis, die mit wenigen grossen Punkten besetzt sind.

13. *Prioptera immaculata* Wagener, *Mittel. Münch.* (1881) 26.

Die kurze Beschreibung dieser Art lässt sich verschieden z. B. auch auf einfarbige Stücke der *sinuata* Oliv. anwenden, denn Wagener hat ein wesentliches Merkmal, die Grösse und Tiefe der drei Gruben jeder Flügeldecke übergangen. Es ist daher ungewiss, ob die bei Manila, (No. 6541) von *R. C. McGregor* gesammelten Exemplare dazu gehören. Ich betrachte sie deshalb vorläufig nur fraglich als:

Prioptera immaculata Wagener, var. *fuscopunctata* var. nov.

Flavo-testacea, nitida, prothorace sublaevi, elytris sat dense fuscopunctatis, trifoveolatis, fovea interna profunda, macula nigra notata. Long. 8–9 mm.

An der Skulptur der Flügeldecken leicht kenntlich. Dieselben sind verworren, fein und ziemlich dicht punktiert, die Punkte erscheinen aber grösser, weil sie in einem durchscheinenden schwärzlichen Kreise stehen. Von den drei Gruben jeder Decke ist die innere gross und tief, mit einer schwarzen Makel versehen, die beiden äusseren sind flacher, die hintere rund, die vordere länglich, undeutlich, eigentlich nur eine Erweiterung des Punktstreifens, welcher die Schulterbeule innen absetzt. In der Basalhälfte der Flügeldecken heben sich drei, von Punktreihen begrenzte, glatte, hellere Längslinien heraus, von denen die erste den Innenrand der tiefen Grube bildet, aber oft bis vor die Spitze sichtbar bleibt. Die zweite endet am Aussenrande der tiefen Grube, die dritte läuft vom Schulterhöcker über dem Aussenrande der Scheibe bis zur Mitte. Das Basaldreieck ist kurz und sehr breit, und steigt zu einer sehr undeutlichen Kante auf, die an der Naht nicht höckerartig erhöht ist.

14. *Prioptera sinuata* Oliv.

Diese Art wurde ebenfalls bei Manila (No. 552 und 8035, *W. Schultze*) gesammelt. In der Normalfärbung hat jede Flügeldecke 6 schwarze Makeln (1, 1, 1, 2, 1), von denen die kleinste, Makel 6, welche Boheman, *Mon. I*; 1850, p. 59 nicht erwähnte, sondern erst *Mon IV*, 1862, p. 25 anführte, unmittelbar neben der Naht vor der Spitze liegt und zuweilen mit dem entsprechenden Flecke der anderen Decke eine gemeinschaftliche Makel bildet. Die drei Gruben jeder Flügeldecke sind klein, äusserst flach und verloschen, aber stärker als die Scheibe punktiert. Boheman

erwähnt (Mon. IV. 25) eine Abänderung „b.“ „Elytrorum maculis parvis, punctiformibus;“ sie bildet den Übergang zur ab. *deficiens*: *Maculis elytrorum plus minusve deficientibus*. Zuerst verschwinden in der Regel die Makeln 6 und 4.

15. *Metriona manilensis* sp. nov.

Subrotundata, sat convexa, subtus dilute testacea, supra rufa, nitida, protecto late explanato flavescente, antennis articulis quinque ultimis albidis, prothorace transversim elliptico, lævi, elytris striato-punctatis, antice vix gibbosis. Long. 7–7.5 mm.

Luzon, Manila, P. I. (*Charles S. Banks*, collector).

Type No. 5343 in der Entomologischen Sammlung des Bureau of Science, Manila, P. I.

Durch die Farbe des Körpers und der Fühler sehr ausgezeichnet. Letztere sind ähnlich wie die ganze Unterseite, blass rötlich gelbbraun die fünf verdickten Endglieder aber weiss. Die Oberseite ist hell und ziemlich lebhaft bräunlich rot, das breite Seitendach durchscheinend und blass gelb. Der Körper ist wenig länger als breit, und der Thorax ist mit den Flügeldecken gleichmässig gerundet. Thorax doppelt so breit als lang, quer elliptisch, die Ecken liegen in der Mitte des Seitenrandes und sind nicht völlig verrundet, sondern bilden einen schwachen, stumpfen Winkel; die Scheibe ist ziemlich glatt. Flügeldecken an der Basis im Bogen ausgeschnitten und so breit als der Thorax, bis zur Mitte gerundet-erweitert, dahinter ähnlich verengt, die Scheibe mässig gewölbt, regelmässig in Reihen punktiert, im Basaldreieck stark abfallend. Von hinten betrachtet bildet die höchste Stelle an der Naht einen sehr schwachen, stumpfen Höcker, der niedriger ist als die Schulterbeulen.

II. COCCINELLIDEN.

1. *Coelophora octopunctata* sp. nov.

Subhemisphærica, testaceo-flava, nitida, prothorace subtiliter punctulato, lateribus haud sinuato, elytris subtiliter punctatis, singulo punctis quatuor (3, 1) nigris. Long. 6.5–7 mm.

Luzon, Manila, P. I. (*P. L. Stangl*, collector).

Type No. 260 in der Entomologischen Sammlung des Bureau of Science, Manila, P. I.

Einer grossen *C. newporti* Muls. ähnlich, aber die Seiten des Thorax vor der Mitte nicht ausgerandet, die Punktierung der Oberseite erheblich feiner und die beiden schwarzen Makeln, die der Basis von Thorax und Flügeldecken bei *newporti* gemeinsam sind, fehlen gänzlich. Die vier schwarzen Punkte der Flügeldecken sind mässig gross und liegen ungefähr wie die von *newporti*: 3 in einer schwach nach hinten gebogenen Querreihe vor der Mitte, der vierte hinter der Mitte, etwas weiter vom Seitenrande entfernt, wie Punkt 3.

Ein anderes Exemplar erhielt ich von Plason aus Java.

2. *Coelophora sexguttata* sp. nov.

Subhemisphaerica, flavo-testacea, prothorace, scutello elytrisque nigris, nitidis, prothorace subtilissime punctato, flavo-marginato, elytris subtiliter punctatis, singulo guttis tribus fulvis, 1, 2 collocatis. Long. 5 mm.

BATAN ISLAND, P. I. (*B. C. McGregor*, collector).

Type No. 7767 in der Entomologischen Sammlung des Bureau of Science, Manila, P. I.

In der Körperform ungefähr mit *inaequalis* Fabr. übereinstimmend, etwas weniger gewölbt als halbkugelig, bräunlich gelb, der Thorax (ausgenommen ein fast gleichbreiter Saum am Vorder- und Seitenrande), das Schildchen und die Flügeldecken schwarz, letztere mit je 3 rötlich gelben Tropfen: 1, 2. Der erste liegt an der Basis am Schildchen, ist wenig länger als breit und hat keinen gerundeten, sondern einen ziemlich geraden Innenrand, der sich allmählich von der Naht entfernt. Die andern Tropfen bilden auf beiden Decken eine leicht nach hinten gebogene Querreihe. Der äussere Tropfen jeder Decke beginnt etwa in der Mitte, der innere wenig hinter derselben, beide sind gerundet und von ähnlicher Grösse als der erste; der äussere ist vom Rande eben so weit entfernt wie vom inneren Tropfen. Dieser liegt der Naht etwas näher.

Die Stirn ist gewirkt, zart punktuiliert, der Thorax verloschen gewirkt, aber stärker als die Stirn punktiert. Die Punkte der Flügeldecken sind doppelt so stark wie die des Thorax.

3. *Sticholotis banksi* sp. nov.

Hemisphaerica, fulva, nitida, creberrime punctata, elytrorum disco, meso- et metasterno nigris. Long. 2.2.-2.5 mm.

Luzon, Manila, P. I. (*Charles S. Banks*, collector).

Type No. 5462, in der Entomologischen Sammlung des Bureau of Science, Manila, P. I.

Gehört in die Abteilung, die einen geflügelten Körper und gleichmässig verworren punktierte Flügeldecken besitzt und ist in Körperform und Farbe der *Sticholotis limbata* Motsch. am ähnlichsten, jedoch höher gewölbt und bedeutend stärker punktiert als diese.

Head finely and closely punctured, fulvous, the apex of the mandibles piceous. Thorax fulvous, three times broader than long, the sides strongly rounded, the surface closely punctured. Elytra closely and moderately strongly punctured, black, the lateral margins broadly fulvous.

4. *Sticholotis ovata* sp. nov.

Breviter-ovalis, convexa, testaceo-flava, nitidula, prothorace sat crebre subtilissime punctato, elytris vitta suturali et laterali, hac medio sub-interrupta fuscis, disco subtiliter punctatis, punctis apicem et latera versus subtilioribus, area elongata communi ante medium sublævi extus stria punctata terminata. Long. 2 mm.

Luzon, Manila, P. I. (*Charles S. Banks*, collector).

Type No. 3033 in der Entomologischen Sammlung des Bureau of Science, Manila, P. I.

Von allen anderen Arten durch breit-eiförmige Körperform und die Bauchlinien verschieden, welche einen Viertelkreis bilden, aber nicht den Hinterrand des 1. Segmentes erreichen, sondern diesem parallel zum Seitenrande ziehen. Blass rötlich gelb, mässig glänzend, ein wenig breiter, vorn erweiterter Nahtsaum und ein in der Mitte eingeschnürter, fast unterbrochener Seitensaum, der hinten mit dem Nahtsaume verbunden ist, hell braun bis schwärzlich. Stirn breit, eben, an den Seiten dichter als in der Mitte punktuert, clypeus jederseits gradlinig nach vorn verengt und für die Fühlerwurzel nicht ausgeschnitten. Thorax mehr als doppelt so breit wie lang, mit ziemlich parallelen, vor der Mitte convergierenden Seiten; auf der Scheibe gleichmässig weniger dicht, aber stärker als die Gegend der Stirn neben den Augen punktiert und äusserst fein und kurz, schlecht bemerkbar behaart. Flügeldecken an der Basis unbedeutend breiter als der Hinterrand des Thorax, bis zur Mitte leicht erweitert, dann verengt und am Ende gemeinschaftlich sehr schmal abgerundet; die Scheibe gewölbt, ziemlich dicht und sehr fein punktiert. Die Punkte sind innen stärker als aussen und hinten. Vor der Mitte ist ein gemeinschaftlicher ovaler Längsraum fast glatt; er wird aussen von einer einreihig stark punktierten, gebogenen, feinen Rinne begrenzt, die hinten in eine kurze, der Naht parallele Punktreihe übergeht. Jede Flügeldecke hat eine gemeinschaftliche schwärzliche Binde an der Naht und eine bräunliche am Seitenrande. Erstere ist mässig breit und erweitert sich vor der Mitte ganz allmählich bis zur Basis. Die Seitenbinde hat in der Mitte einen winkeligen Ausschnitt, welcher sie fast unterbricht. Die Schulterbeule ist sehr klein und niedrig, der Körper aber vollkommen geflügelt.

Das nur stumpf zugespitzte Endglied der Maxillartaster, der eiförmige Körper und die vom Hinterrande des ersten Bauchsegmentes entfernten Schenkellinien dürften später eine Trennung des Tieres von *Sticholotis* nötig machen.

5. *Aspidimerus tristis* sp. nov.

Subrotundatus, convexiusculus, niger, crebre brevissimeque griseo-pubesens, quasi pruinosis, margine antico clypei, limbo laterali prothoracis, pectore abdomineque piceo-rufis; supra dense subtilissimeque punctulatus. Long. 2.5 mm.

Luzon, Manila, P. I. (*Charles S. Banks*, collector).

Type No. 4903, in der Entomologischen Sammlung des Bureau of Science, Manila, P. I.

Gerundeter und merklich flacher als die übrigen Arten, durch die schwarze Farbe der Oberseite leicht kenntlich. Diese Farbe wird durch eine dichte äusserst zarte und kurze greise Behaarung zum Teil verdeckt.

Die Unterseite und der grösste Teil der Beine sind rötlich pechbraun gefärbt, ebenso ein feiner Saum am Vorderrande des Kopfschildes und ein breiterer Streifen an den Seiten des Thorax. Die Punktierung der Oberseite ist sehr dicht und fein.

Durch die Tätigkeit der Mitglieder des Bureau of Science in Manila ist die Zahl der auf den Philippinen gefundenen Coccinelliden von 18 Arten, die der Catalog von G. A. Baer, Ann. Soc. Ent. Fr. (1886) 173, anführt, auf 42 gestiegen. Besondere Erwähnung verdienen:

6. *Leis dunlopi* Crotch. (6406, H. M. Cuzner).
7. *Leis dimidiata* Fabr. ab. *bicolor* Hope (255, P. L. Stangl).
8. *Rodolia rufopilosa* Muls. (249 und 5570, C. S. Banks).
9. *Rodolia podagrica* Ws. (252, C. S. Banks).
10. *Ortalia pusilla-mesta* Ws. (5462, C. S. Banks).
11. *Platynaspis nigra* Ws. (2250 und 5027, C. S. Banks).
12. *Stethorus pauperculus* Ws. (4737, C. S. Banks).
13. *Stethorus rotundatus* Motsch. (4950, C. S. Banks).

Alle *Stethorus*-Arten nähren sich von der sehr schädlichen „Spinnmilbe,“ „red spider,“ „red mite,“ *Tetranychus telarius* Linn. Die beiden vorstehend genannten Arten unterscheiden sich leicht durch folgende Punkte: *pauperculus* Ws. ist breit oval, auf den Flügeldecken verhältnissmässig kräftig, sehr dicht narbig punktiert, hat aber einen gemeinschaftlichen schmal ovalen glatten Raum an der Naht vor der Mitte, an dessen Aussenrande die Punkte eine oder mehrere nicht ganz regelmässige Reihen bilden; *rotundatus* Motsch. ist etwas grösser, gerundet, auf den Flügeldecken ziemlich gleichmässig und äusserst fein punktiert. Die Punkte werden nach aussen unbedeutend stärker.

✓ DIE RUTELIDEN DER PHILIPPINISCHEN INSELN.

VON FR. OHAUS.

(Steglitz-Berlin, Germany.)

In einer kleinen Sendung von Ruteliden aus der Sammlung des Bureau of Science in Manila, die mir im Sommer 1909 zur Bestimmung zugeht, befanden sich auch einige neue Arten, deren Beschreibung mir Anlass gab, auch die von Prof. Carl Semper und Mr. J. Whitehead auf den Philippinen gesammelten Ruteliden, die sich in meiner Sammlung befinden, zu studieren. Der ersten Sendung des Bureau of Science folgte im Januar eine bedeutend reichhaltigere zweite, dieser im April dieses Jahres eine dritte, beide wieder eine ganze Reihe neuer Arten enthaltend. Meine ursprüngliche Absicht, eine Monographie der Ruteliden der Philippinen zu liefern gab ich angesichts des so reichlich zuströmenden Materials vorläufig auf, weil ich mir sagte, dass eine solche bei dem wissenschaftlichen Eifer und der regen Sammeltätigkeit der Herren vom Bureau of Science doch in kurzer Zeit nicht mehr genügen würde. Im Folgenden gebe ich daher nur eine Beschreibung der neuen Arten und eine alphabetische Liste aller bis jetzt bekannten Ruteliden der Philippinen mit Literatur- und Fundortsangaben; von den Beziehungen, die die Ruteliden der Philippinen zu denen der übrigen Teile der orientalischen Region haben, möchte ich kurz die folgenden hervorheben. Von den beiden Hauptgruppen der Ruteliden, den Arten mit vertical gestellter Oberlippe—Rutelinae psalidochilidae—und denen mit horizontal liegender Oberlippe—Rutelinae ptyeladenochilidae—sind die ersteren, wie in der ganzen orientalischen Region, nur durch die Gattung *Adoretus* vertreten. Von dieser sind bisher nur 4 Arten gefunden worden, darunter der weit verbreitete *Adoretus umbrosus* Fabr. und sein nächster Verwandter, der auch auf Malakka und Formosa vorkommende *A. ranunculus* Burm. Von dem, den beiden genannten Arten sehr nahe stehenden *A. tenuimaculatus* Waterh. aus China und Japan wissen wir bestimmt, dass er im Larvenstadium mit Kulturpflanzen (Zuckerrohr, Bananen), die nur durch Wurzelschösslinge verbreitet werden, verschleppt wird, von einem anderen nahen Verwandten, dem *A. versutus* Har. macht dies die eigentümliche geographische Verbreitung —St. Helena, Seychellen, Ceylon und Vorderindien, Singapur, Canton, Batavia, Viti, Samoa—höchst

wahrscheinlich, und darum halte ich auch die Einschleppung von *umbrosus* und *ranunculus* auf den Philippinen für höchst wahrscheinlich. Auch *A. philippinicus* Pic ist mir in dieser Beziehung verdächtig und nur den *A. luridus* Blanch. der einer ganz anderen Gruppe der Gattung angehört und seine nächsten Verwandten im Himalaya und auf Celebes hat, halte ich für wirklich endemisch.

Die zweite Hauptgruppe, die Ruteliden mit horizontaler Oberlippe, sind durch die Abteilungen der Anomalini (mit 9-gliedrigen Fühlern) und die sogenannten echten Ruteliden (mit 10-gliedrigen Fühlern) vertreten. Aus der Abteilung der Anomalini ist die artenreiche Gattung *Anomala* auch hier mit der höchsten Artenzahl vertreten. Alle bis jetzt hier gefundenen Arten sind endemisch mit Ausnahme der weit verbreiteten *A. varicolor* Gyllenh. die aber auch eine gut charakterisierte Lokalform bildet. Die Gattung *Mimela*, in Vorder- und Hinter-Indien, China, Japan und den grossen Sunda-Inseln mit etwa 80 Arten verbreitet, ist auf den Philippinen nur durch 3 Arten vertreten; davon ist nur eine Art endemisch, die zweite, *maculicollis* von Sibay, ist in ganz Borneo verbreitet, und die dritte, die in Java häufige *blumei* Hope, wurde mir bisher nur einmal von einem Händler mit der Fundortsangabe Manila zugeschickt und muss daher vorläufig noch als zweifelhaft aufgeführt werden.

Von den Popillien ist die Gattung *Pseudomalaia* mit allen bekannten 4 Arten endemisch, und auch die hier vorkommenden Arten der Gattung *Popillia* sind alle endemisch und —vielleicht mit Ausnahme der *variabilis*—so abweichend von den übrigen Arten der Gattung, dass man für sie eine besondere Untergattung gründen müsste. Ihre nächsten Verwandten hat *Pseudomalaia* auf Celebes, Saleyer und Sangir, während die *Popilla*-Arten teils eine Weiterentwicklung von *Pseudomalaia*—mit stärkerem Mesosternalfortsatz—darstellen, teils Anklänge an Celebes- und Himalaya-Formen zeigen.

Die ganze Abteilung der Anomalini ist relativ jung und noch in voller Entwicklung begriffen, was sich einerseits daraus ergibt, dass sich alle Unterabteilungen und Gattungen noch durch vermittelnde Formen mit einander verbinden lassen, andererseits daraus, dass sie in früh isolirten Gebieten, wie Australien (hier abgesehen von der mit Zuckerrohr eingeschleppten *Anomala antiqua* Gyllenh. aus China), Madagascar und Chile-Patagonien vollständig fehlen.

Die echten Ruteliden, in der orientalischen Region durch die Gruppe der Parastasiiden vertreten, sind ausgezeichnet durch ihren ungemein mannigfaltigen sexuellen Dimorphismus; es giebt kaum irgend einen Teil des Körpers, der hier nicht Träger sekundärer sexueller Merkmale wäre und gerade die sekundären Geschlechtsmerkmale sind es, die hier in ersten Linie zu einer Differenzierung der Formen geführt haben. So sind die ♂ der *Peperonta harringtoni* Westw. vom Himalaya, der *Dicaulo-*

cephalus feae Gestro. resp. *fruhstorferi* von Sumatra resp. Tonkin, der *Ceropliphana modiglianii* Gestro von Sumatra und Borneo so verschieden, dass man für sie eigene Gattungen aufgestellt hat; ihre ♀ aber sind einander so ähnlich, dass man Mühe hat, sie als Arten von einander zu unterscheiden und für sich allein betrachtet, sicher nie auf den Gedanken kommen würde, sie in verschiedene Gattungen zu stellen. Soweit bis jetzt bekannt, sind die Parastasiiden Bergbewohner und leben im Larvenzustand, wahrscheinlich auch zumeist als ausgebildete Insekten in abgestorbenen Bäumen, einige Arten in den Wurzeln abgestorbener Bäume, die sie nur gelegentlich zur Paarung oder zum Aufsuchen neuer Brutstellen verlassen. Entsprechend dieser zumeist versteckten Lebensweise werden die Käfer selten gefunden. Nach unserer Kenntniss von ihrer Biologie müssen wir es für unwahrscheinlich halten, dass die Arten innerhalb der Region verschleppt werden könnten und tatsächlich ist uns auch kein sicherer Fall einer solchen Verschleppung bekannt. Wenn wir nun ausserdem berücksichtigen dass wir in den Parastasiiden sehr alte Formen vor uns haben, aus der Gruppe der echten Ruteliden wohl die ältesten, dann dürfen wir diejenigen philippinischen Arten, die sich neben den Philippinen auch in anderen Teilen der orientalischen Region finden, unbedenklich als Relikte auffassen, als Überbleibsel aus der Zeit, da die Philippinen noch mit dem Festland und den grossen Sunda-Inseln zusammenhingen. Von diesem Gesichtspunkte aus betrachtet ist jede der hier vorkommenden Arten interessant.

Parastasia confluens Westw. eine der ältesten Formen der Gruppe, findet sich ausser auf Luzon auch auf Malakka, Sumatra, Java, Borneo, Celebes, Salayer, Amboina, Ceram, Buru, Aru, Sangir, Ternate, Salawati und Neu-Guinea.

Parastasia indica Ohs. findet sich ausser auf Nord-Luzon im Himalaya und in Tonkin.

Parastasia westwoodi Waterh. findet sich auf Mindoro, Malakka, Sumatra und Java.

Parastasia nonfriedi Ohs. von Palawan hat dieselbe Verbreitung.

Die genannten 4 Arten haben sich in den verschiedenen Teilen ihres Verbreitungsgebietes unverändert erhalten, so dass es nirgends zur Bildung von Lokalrassen gekommen ist. Anders ist es mit der weitverbreiteten *P. bimaculata* Guer. Diese findet sich unverändert auf Malakka, Sumatra, Borneo, Bangka, Banguay, Celebes, Ternate, Halmahera, Buru, Amboina, Ceram und im Westen von Neu-Guinea; zur Bildung von Lokalrassen, die zumeist als selbständige Arten beschrieben wurden, kam es auf den Andamanen und Nicobaren, in bestimmten Teilen von Celebes, auf den Salomon Inseln, Tonga Inseln und im Osten von Neu-Guinea (Sattelberg). Auch die *P. nigriceps* Westw. und *nigroscutellata* Ohs. von Nord-Luzon und Negros sind als solche Lokalformen der *bimaculata* Guer. zu betrachten.

Parastasia discolor Westw. von Nord-Luzon hat ihre nächsten Verwandten, die *scutellaris* Erichs. auf Malakka, Sumatra und Borneo, die *unicolor* Arrow auf Borneo; auch diese 3 Arten kann man als relativ noch junge und darum noch wenig differenzierte Lokalformen einer früher einheitlichen Art auffassen. Als ich in meiner Monographie der Parastasiiden¹ die Unterschiede dieser drei Arten auseinandersetzte, gelang mir dies ziemlich leicht, weil ich nur wenige Stücke vor mir hatte; inzwischen habe ich aus Sumatra und Borneo mehrere Stücke erhalten, durch welche die Unterschiede zwischen *scutellaris* Erichs. und *unicolor* Arrow schon bedenklich verwischt werden.

Stärker ist die Differenzierung bei *P. canaliculata* Westw. die sich von ihren nächsten Verwandten, der *rufopicta* Westw. und *birmana* Arrow aus dem mittleren und östlichen Himalaya durch den eigenartigen sexuellen Dimorphismus unterscheidet.

Die *Lutera nigromaculata* Ohs. von Camarines ist dagegen von ihrer nächsten Verwandten, der *L. luteola* Westw., deren Verbreitungsgebiet den Himalaya, die Nicobaren, Adonara, Sumatra und Java umfasst, durch eine Reihe guter Merkmale geschieden.

Von philippinischen Ruteliden habe ich für meine Sammlung schon früher erworben einen Teil der Ausbeute von Prof. Semper, die ich teils von seinem Bruder, G. Semper, in Altona, teils mit der Sammlung des Herrn W. L. C. Weber in Hamburg erhielt; sodann die ausserordentlich reiche und interessante Ausbeute von J. Whitehead aus dem Tring-Museum; ferner lagen mir vor die Ruteliden des Madrider Museums, die ausser einer spärlichen Anzahl bekannter Arten zwei neue, die *Popillia conopyga* Ohs. und *Lutera nigro-maculata* Ohs. enthielten; auch Herr G. A. Baer, der Verfasser des Katalogs der philippinischen Käfer, schickte mir seine Sammlung und überliess mir daraus die mich interessierenden Arten; ihm widme ich die einzige darin enthaltene neue Art *Euchlora baeri*.

ANOMALA Samouelle.

In der Anordnung der neuen Arten folge ich Burmeister's Handb. IV. 1. und benutze auch dessen Einteilung der Gattung in wenige Undergattungen.

Anomala (Rhinoplia) infans sp. nov.

Parva, tota testacea, nitida, capite rufo tarsis tibiatarumque dentibus paulo obscurioribus. Clipeus trapezoidalis planus marginibus lateralibus et apicali alte elevatis, angulis anterioribus acutis, politus impunctatus; sutura frontalis recta impressa; oculi permagni globosi; frons cum vertice disperse punctulata. Thorax fere quadratus convexus undique anguste marginatus lateribus arcuatus disperse punctulatus. Scutellum parvum cordatum sat dense punctulatum. Elytra parallela convexa

¹ Deutsche Ent. Ztschr. (1900), 244.

humeris prominentibus regulariter striata et in striis sat fortiter punctata. Propygidium pygidii fere longitudine margine posteriore disperse punctulatum. Pygidium triangulare apice parum rotundatum sat dense punctatum, nudum, lateribus solum disperse ciliatum. Segmenta abdominalia disperse punctulata nitida linea punctorum piligerorum praedita. Metasternum nitidum, punctulatum vix pilosum. Tibiæ anticæ tridentatæ, dente apicali magno, tarsi graciles longi, ungue majore tarsorum anticorum mediorumque longo gracili vix perspicue inciso. Antennæ flavæ, clava quam funiculus brevior.

Long. 6.5, lat. hum. 3 mm.

LUZON, P. I. (*C. Semper*, collector).

Type, ein einzelnes ♂ in meiner Sammlung.

Die Mundteile sind sehr klein. Am Oberkiefer ein kräftiger Mahlzahn und ein einfacher, scharf vorspringender Spitzenzahn; am Unterkiefer trägt die äussere Lade an der Spitze einen grossen oben abgeflachten, unten leicht ausgehöhlten, vorn zugerundeten Zahn (ähnlich wie bei *Pharaonus* und *Gnatholabis*), darunter jederseits einen kleineren ähnlichen Zahn und ganz an der Basis eine Querreihe von 3 scharf zugespitzten Zähnen. Die Flügeldecken sind regelmässig gefurcht und in den Furchen kräftig punktiert, primäre Rippen und Interstitien gewölbt, das Interstitium subsuturale durch eine nur ganz am Anfang etwas unregelmässige Punktreihe in 2 sekundäre Rippen geteilt. Das lange Klauenglied ist gezähnt, die grössere Klaue an Vorder- und Mittelfüssen sehr lang und schlank, kaum sichtbar auf der oberen Kante eingeschnitten.

Anomala (Heteroplia) flavoscutellata sp. nov.

Oblongo-ovata, parva, postice paulo deplanata, nitida, flavotestacea vertice rufescente, thorace maculis duabus fusco-brunneis, elytris totis brunneis, supra glabra, subtus dispersissime pilosa. Clipeus trapezoidalis margine anteriore alte elevatus, leviter excavatus, cum fronte et vertici rufescentibus disperse punctatus, sutura frontalis postice arcuata vix perspicua; oculi sat magni globosi, antennæ clava (♂) magna stipitis longitudine. Thorax longitudine dimidio fere latior lateribus regulariter arcuatus undique anguste marginatus, sat dense at non confluentur punctulatus, medio subtiliter sulcatus. Scutellum parvum dense punctatum. Elytra postice paulo ampliata et deplanata regulariter punctato-striata, interstitio subsuturali lato disperse punctato. Pygidium latum, parum convexum, disperse punctatum lateribus ciliatum. Segmenta abdominalia et pectus sat fortiter punctata sparsim pilosa. Pedes breviores sat robusti, tibiæ anticæ fortiter bidentatæ, tarsi graciles longi, anteriorum unguis major incrassatus incurvatus, supra dente parvo armatus, intermediorum unguis major longus gracilis apice æqualiter fissus.

Long. 8, lat. max. 4.5 mm.

Luzon, Province of Cagayan, Cape Engaño, P. I. (*J. Whitehead*, collector).

Type, ein ♂ in meiner Sammlung.

Kopf rötlichgelb, Halsschild mit 2 grossen dunkelbraunen Flecken, neben denen nur am Rand und auf einem schmalen Mittelstreifen die gelbe Grundfarbe sichtbar wird. Schildchen blassgelb, Flügeldecken dunkelbraun, nur die Schulter und ein schmaler Längsstreifen gelblich, Afterdecke, Unterseite, Beine und Fühler gelb. Die Mundteile sind klein aber kräftig gebaut, am Oberkiefer ist der Spitzenzahn gespalten, der Unterkiefer trägt an der äusseren Lade sechs kurze spitze Zähne in der gewöhnlichen Reihenfolge 1, 2, 3. Am Forceps (Periphallium) sind die Parameren symmetrisch, an der Basis verschmälert und etwa im Winkel von 45° nach aussen divergierend, die Spitzen verbreitert, zugrundet und auf der Oberseite gekielt; die Ventralplatte des Mittelstückes ist verlängert, mit der Spitze zwischen die Parameren reichend; ausserdem trägt das vas deferens eine lange hornige gebogene Spitze die zwischen den Parameren hervortritt.

Anomala (Heteroplia) macrophthalma sp. nov.

A. macrophylla Wied. et *A. castelnaui* Ohs. proxime affines. Oblongovata, parum convexa, testacea capite rufescente, nitida, supra glabra, subtus femoribus et pectore dense ac longe villosis.

Long. 11, lat. max. 5.5 mm.

Luzon, Province of Cagayan, Aparri, P. I. (*R. C. McGregor*, collector).

Type, ♂ in meiner Sammlung. (No. 12456 des Bureau of Science.)

Aus der nächsten Verwandtschaft der *A. macrophylla* Wied. von Java und *castelnaui* Ohs., die ich irrthümlicher Weise mit dem Fundort „Brasilien“ erhielt, während sie in Wirklichkeit auf Malakka, in Siam und Cochinchina und auf Sumatra vorkommt. Die genannten drei Arten sind nahe verwandt, unterscheiden sich aber leicht durch die Bezeichnung der Vorderschienen, die bei der *macrophylla* neben dem Spitzenzahn einen grossen, weit abstehenden Seitenzahn tragen, bei der *macrophthalma* einen schwachen, aber deutlichen Seitenzahn, während sie bei der *castelnaui* zahllos sind.

Körperform gestreckt oval, nach vorn und hinten gleichmässig verbreitert, leicht gewölbt, Farbe blassgelb, glänzend, nur der Kopf leicht rotgelb, Oberseite kahl, unten die Brust und Schenkel lang und dicht behaart. Kopfschild so lang als breit, die Vorderecken ganz schwach gerundet, der Rand ringsum fein aufgebogen, dicht und fein punktiert; die Stirnnaht ist deutlich, gerade, Stirn und Scheitel ziemlich dicht fein punktiert. Die Augen ganz auffallend gross, stark vorgequollen, nur etwa zu einem Drittel von den schmalen Augenkielen überzogen. Fühlerkeule so lang wie Stirn und Scheitel zusammengenommen, verbreitert, grau, die Geissel gelb. Die Mundteile sind stark zurückgebildet,

Unterkieferhelm mit drei starken Borsten statt der Zähne, Halsschild doppelt so breit als lang, vor der Mitte verbreitert, Vorder und Hinterecken stumpf, nicht vorgezogen, die Mitte der Länge nach leicht gewölbt mit feiner Längsfurche, die Oberfläche zerstreut fein punktiert. Schildchen relativ gross, zerstreut punktiert. Flügeldecken auf der Scheibe regelmässig und tief gefurcht, Rippen und Interstitium gut gewölbt, im Interstitium subsuturale zwei sekundäre Rippen, zwischen die sich von der Basis bis zur Mitte eine feine tertiäre schiebt; im zweiten und dritten Interstitium eine unregelmässige Reihe grober Punkte; an den Seiten sind die Furchen und Punkte seichter. Afterdecke fein punktiert und zerstreut kurz behaart, ebenso die Bauchringe. Vorderschienen lang und schmal, mit einem langen, schlanken Spitzenzahn und kurzem, schwachen Seitenzahn; Mittelschienen in der Mitte verbreitert und hier mit einer langen Stachelkante, nach der Spitze hin verschmälert; Hinterschienen kurz, an der Spitze am breitesten, vor der Spitze nicht eingeschnürt, mit einer Stachelkante. Von den Vorderklauen ist die innere länger, leicht verdickt und gespalten; von den Mittelklauen ist die äussere an der Spitze leicht eingeschnitten, nicht grösser als die innere; die Hinterklauen sind beide gleich lang, einfach; alle Klauenglieder mit einzelnen langen Borsten.

Anomala (in specie) proctolasia sp. nov.

Præcedenti similis plerumque minor, differt præcipue clipeo quadrato angulis vix rotundatis, thorace ante elytrorum basim angustato, tibiis fortiter dentatis, pygidio dense piloso. Parva, oblonga, convexa, nitida, aut tota flavo-testacea vix ænescens abdomine fusco-æneo, aut fusco-ænea, capite et thorace cum pedibus testaceis, viridi-ænescentibus, thorace maculis duabus fusco-æneis ornato. Clipeus transversus angulis vix rotundatis margine undique elevato fusco, planus dense rugose-punctatus; sutura frontalis recta infuscata; frons cum vertice testacea macula fusco-viridi pone oculos ornata, dense rugose punctulata punctis majoribus prope oculos intermixtis. Thorax transversus medio dilatatus antice et postice æqualiter fere angustatus angulis anticis acutis paulo productis, posticis obtusis rotundatis, undique grosse, hic illic confluentur punctatus, sulculo basali non interrupto. Scutellum grosse punctatum. Elytra parallela regulariter et profunde sulcata et in sulcis transversim punctata. Pygidium opacum dense rugulose-punctatum et pilis appressis vestitum; segmenta abdominalia dense punctata linea piligera solum prædita, metasternum densius pilosum. Pedes robusti, tibiæ anticæ dentibus duabus validis fuscis armatæ. Antennæ testaceæ clava quam stipes in utroque sexu brevior.

♂ ♀. Long. 9.5, lat. 5 mm.

LUNZON, Manila, P. I. (*Donckier*, collector); POLILLO, P. I. (*R. C. McGregor*, collector).

Das Kopfschild ist viereckig, etwas breiter als lang, die Ecken kaum gerundet, der Rand ringsum deutlich aufgebogen, schwarzbraun. Das Halsschild ist ziemlich hochgewölbt, in der Mitte verbreitert, vor den Flügeldecken deutlich eingeschnürt, die stumpfen Hinterecken leicht gerundet, nach vorn stärker verschmälert, die spitzen Vorderecken vorgezogen, die Oberfläche dicht und grob punktiert, die Mitte hie und da runzelig. Die Flügeldecken sind regelmässig gestreift, die Punkte in den Furchen meist quergestellt, im ersten oder subsuturalen Interstitium 2 regelmässige secundäre Rippen, zwischen die sich an der Basis der Anfang einer tertiären schiebt; in dem zweiten und dritten Interstitium sind je 2 secundäre regelmässige Rippen, in den seitlichen Interstitien nur eine secundäre Rippe. Die Oberkiefer haben zwei Spitzenzähne. Am Forceps ist das Mittelstück sehr gross, die Parameren sind symmetrisch, von der Basis rasch sehr stark verengt und nach unten in einen Lappen ausgezogen, der eine nach vorn gerichtete Spitze trägt.

Anomala ovatula sp. nov.

Parva, ovata, alte convexa, testacea variis fusco-æneis signaturis ornata, nitida, supra glabra, subtus sparsissime griseo-hirsuta.

♂ ♀ Long. 9-10, lat. 5.5-6 mm.

MINDANAO, Camp Keithley, P. I. (*Mrs. M. S. Clemens*, collector); LEYTE, P. I. (*J. Whitehead*, collector); PALAWAN, P. I. (*C. M. Weber*, collector).

Eine kleine, hochgewölbte, eiförmige Art, die auf den ersten Blick einer kleinen *Mimela discoidea* von Java recht ähnlich sieht. Die Grundfarbe ist ein helles Scherbengelb, das in verschiedener Ausdehnung dunkel erzgrüne Zeichnung trägt. Bei dem hellsten Stück ist alles hell scherbengelb, nur der Kopf (ohne Kopfschild), eine grosse Makel auf dem Thorax, die Vorder- und Hinterrand berührt und nur die Seiten breit freilässt, und die Umgebung des Schildchens in geringer Ausdehnung dunkel erzgrün. Beim dunkelsten Stück ist der ganze Kopf mit dem Kopfschild, das Halsschild bis auf einen schmalen Saum, das Schildchen, die Flügeldecken mit Ausnahme eines Längswisches innen neben der Schulter und des Hinterrandes, sowie die Schienen dunkel erzgrün. Das Kopfschild ist um die Hälfte breiter als lang, die Ecken stark gerundet, der Rand fein aufgebogen und schwarz gesäumt, die Oberfläche fein gerunzelt. Die Stirnnaht ist fein erhaben, gerade, die Stirn schwach abgeflacht, dicht runzelig, der Scheitel gewölbt, ziemlich dicht und kräftig punktiert. Die Mundteile sind trotz ihrer Kleinheit kräftig, die Oberkiefer mit drei, die Unterkiefer mit sechs spitzen Zähnen; die Fühlerkeule in beiden Geschlechtern nahezu gleich lang. Das Halsschild ist in der Mitte verbreitert, nach vorn und hinten gleichmässig verengert, die Vorderecken deutlich, vorgezogen, überall dicht und kräftig punktiert; das Schildchen ähnlich, aber etwas weit-

läufiger. Die Flügeldecken sind regelmässig tief gefurcht und in den Furchen punktiert, die Punkte in den Furchen fein unwallt, die Rippen glatt, punktfrei. Im ersten oder subsuturalen Interstitium stehen 2 gut gewölbte secundäre Rippen, die durch eine nur vorn unregelmässige und verbreiterte Punktreihe getrennt sind; das zweite und dritte Interstitium enthalten je zwei secundäre Rippen mit regelmässiger trennender Punktreihe, das vierte und fünfte nur je eine secundäre Rippe. Die Afterdecke ist höckerig mit grossen grubigen Punkten, glänzend, nur am Rand spärlich gewimpert. Die Unterseite ist grob und dicht punktiert, glänzend, die Vorderschienen mit einem kräftigen Seitenzahn neben dem Spitzenzahn, die Mittel- und Hinterschienen leicht verdickt mit zwei Stachelkanten.

Anomala palawana sp. nov.

Præcedenti proxime affinis, minor, differt capite, thorace scutelloque viridi-aneis nitidissimis subtiliter sparsim punctatis, pygidio dense aciculato sericeo, opaco.

♂ Long. 7.5, lat. max. 4.5 mm.

PALAWAN, P. I. (von *G. Semper* erhalten).

Körperform der vorhergehenden Art, etwas flacher und kleiner. Grundfarbe braun, erzgrün, lebhaft glänzend, die Flügeldecken gleichmässig bräunlichgelb. Kopf, Halsschild und Schildchen sind zerstreut und fein punktiert, glänzend poliert, das Halsschild mit tiefem Seitengrübchen. Die Flügeldeckenskulptur ist wie bei der vorhergehenden Art. Die Afterdecke ist dicht runzelig mit feinsten Höckerchen, matt seidenartig glänzend, über die ganze Oberfläche zerstreut gelbgrau behaart; auch Brust, Bauchringe und Schenkel sind etwas dichter behaart.

Anomala semperia sp. nov.

A. ovatulæ affinis, minor, sat deplanata, differt præcipue elytris tota superficie punctis minimis sat dense obtectis et leviter punctato-striatis, striis vix impressis, pygidio quadrimaculato, maculis leviter foveolatim impressis.

♂ ♀ Long. 8–8.5, lat. max. 4–4.5 mm.

Luzon, P. I. (*C. Semper*, collector).

Hellgelb mit lebhaftem grünem Erzschilder, zwei sich hinten berührende Makeln auf dem Scheitel, eine grosse zackige Makel auf dem Halsschild und beim ♂ vier Makeln auf der Afterdecke braungrün. Die Punktierung ist auf Kopf, Vorderrücken und Schildchen fein, wie bei der vorhergehenden Art, aber dichter und diese Teile nicht so glänzend. Die Flügeldecken sind regelmässig, aber seicht gefurcht und in den Furchen einfach punktiert, das subsuturale Interstitium mit einer Punktreihe, die vor der Spitze erlischt und bei der Basis furchenartig eingedrückt ist; das zweite und dritte Interstitium mit unregelmässigen Punkten; die ganze Oberfläche der Flügeldecken ist mit feinen

Pünktchen überall bedeckt und erhält dadurch einen leichten Seidenglanz. Die Afterdecke ist gelb, glänzend, nur am Rand spärlich gewimpert, beim ♂ mit vier braungrünen Makeln, von denen die zwei grösseren bei den Vorderecken, die zwei kleineren bei der Spitze in flachen Grübchen stehen; beim ♀ ist sie gleichmässig rötlichgelb (es liegen mir nur 1 ♂ und ♀ vor). Unterseite fast kahl, an den Vorderschienen in beiden Geschlechtern der Seitenzahn klein, Mittel- und Hinterschienen nicht wadenartig verdickt.

Es ist möglich, dass man die genannten 3 Arten, wie auch die nahe verwandte *leotaudii* Blanch. die eine grosse *ovatula* mit dichter feiner Punktierung und tiefer Furchung der Flügeldecken ist, später einmal als Rassen einer Art auffassen wird, so lange nur so spärliches Material vorliegt, lässt sich diese Frage noch nicht entscheiden.

Anomala leotaudii Blanch. var. **fuscoviridis** var. nov.

Oben und unten gleichmässig dunkel erzgrün, mässig glänzend, nur die Fühler rötlich.

Luzon, Province of Cagayan, Cape Engaño, P. I. (*J. Whitehead*, collector).

Anomala humeralis Burm.

A. eydouxi Blanch. ist synonym zu *A. humeralis* Burm. Das Stück der *humeralis*, welches Blanchard vorlag, ist ein grosser ♂, bei welchem sich von dem breiten tiefschwarzen Schulterfleck eine etwas verwaschene und unterbrochene dunkle Binde quer über die Flügeldecken zur Naht herüberzieht, bei welchem auch die Spitzenbuckel eine dunkle Makel tragen und der Vorderkörper dunkel erzgrün gefärbt ist. Solche dunkle Stücke sind auf den Philippinen recht selten; sie sind häufiger bei der nächst verwandten *aneiventris* Fairm. die auf Neu-Guinea eine rein schwarzflügelige Varietät hat. Im Gegensatz zu dieser dunklen Form der *humeralis* hat Blanchard die hellen Stücke, bei welchen der Vorderkörper zuweilen rötlich durchscheint und die hellgelben Flügeldecken nur einen kleineren dunklen Fleck aussen neben der Schulter, aber keine Querbinde und keinen Fleck auf dem Spitzenbuckel haben, als *A. eydouxi* beschrieben. Da sich bei reichlichem Material alle Färbungsübergänge von solchen mit rein hellgelben Flügeldecken, bei welchen die Partie aussen neben der Schulter nur leicht dunkler gefärbt ist, bis zu dem oben erwähnten dunklen Stück, das Blanchard vorlag, feststellen lassen, so hat es keinen Sinn, den von Blanchard gegebenen Namen für die hellen Stücke beizubehalten; man müsste ja sonst alle davon abweichenden dunkler gefärbten Stücke auch mit besonderen Namen bezeichnen.

A. exarata Burm. unterscheidet sich von der zunächst verwandten *A. sulcatula* Burm. hauptsächlich durch die Sculptur der Flügeldecken. Bei der *exarata* sind die primären Rippen auf der Scheibe etwas höher gewölbt und sind entweder ganz punktfrei oder tragen nur vereinzelte

grobe Punkte. Das erste oder subsuturale Interstitium hat zwischen 2 sekundären Rippen eine tertiäre, die an der Basis unregelmässig und abgeflacht, weiterhin durch quereingedrückte grobe Punkte in einzelne Höckerchen aufgelöst ist. Bei der *sulcatula* sind die primären Rippen von der Basis bis zum Hinterrand mit einer Reihe grober Punkte versehen. Das subsuturale Interstitium hat zwischen den beiden sekundären Rippen einen breiteren Zwischenraum, der ganz unregelmässig dicht punktiert ist. Ausserdem ist die ganze Oberfläche der Flügeldecken mit feinen Pünktchen bedeckt, die der *exarata* fehlen. Beide Arten sind durch ein sekundäres sexuelles Merkmal ausgezeichnet, das den nächst verwandten Arten fehlt. Beim ♂ tragen die Hinterschienen einen kräftigen Zahn an der unteren Kante, der an der Spitze mit 2-3 in Grübchen stehenden Gelenkborsten versehen ist. Bei einigen ♂ der *exarata* sind die Trochanteren der Hinterbeine zahnartig verlängert, bei der *sulcatula* nicht. Die letztere Art fand Herr Baer bei Manila auch in nahezu schwarzen Stücken.

Anomala whiteheadi sp. nov.

Anomala exarata proxime affinis. Plerumque minor; ovata, tota fusco-cupreo-ænea, nitidissima, splendore aurichalceo suffusa. Clipeus transversus angulis parum rotundatis subtiliter rugulose-punctulatus; sutura frontalis recta pone latera foveatim impressa; frons cum vertice dispersus ac fortius punctata. Thorax sicut caput punctatus ad latera foveatus medio dilatatus antice valde angustatus angulis anticis subrectis vix productis, basi ante scutellum sat fortiter producta sulculoque basali non interrupto. Scutellum disperse punctatum. Elytra regulariter punctato-seriata, seriebus pone apicem solum in disco sulcatis, ad latera transversim plicata. Pygidium sericeum dense subtiliter aciculatum undique sparsim pilosum; pectus rugulose-punctatum fere opacum densius vulpino-hirsutum. Pedes robusti, tibiæ anticæ bidentatæ; antennæ fuscæ, clava ♂ stipitis longitudinali, ♀ brevior.

♂ ♀ Long. 10.5-12, lat. 6-6.5 mm.

LUZON, Province of Albay, P. I. (*J. Whitehead*, collector).

Die Flügeldecken sind mit feinen Punktreihen versehen, die nur auf der Scheibe nahe dem Hinterrand furchenartig eingedrückt sind. Es sind nur die, die primären Rippen begrenzenden primären Punktreihen vorhanden, im ersten Interstitium 2, im zweiten und dritten nur je eine einfache Punktreihe; an den Seiten und bei der Naht befinden sich einige wenige grobe Querrunzeln, als wären die Käfer beim Ausschlüpfen verkrüppelt.

Anomala despumata sp. nov.

Anomalæ sulcatulæ proxime affinis differt præcipue elytrâ nitidissimis subtilissimè punctulatis, non striatis. Ovalis, parum convexa, nitidissima aut viridi- aut cupreo-ænea aurichalceo splendore suffusa. Clipeus

transversus margine elevato angulis parum rotundatis, subtiliter ac confluentur punctulatus; frons confluentur, vertex disperse sat grosse punctata. Thorax a basi antice æqualiter angustatus angulis anticis vix productis, sulculo basali medio interrupto, sicut vertex disperse sat fortiter punctatus. Scutellum politum vix perspicue punctulatum. Elytra regulariter at subtiliter punctato-seriata, haud sulcata, polita, ad latera transversim plicata. Pygidium subsericeum dense transversim aciculatum sat dense breviter pilosum. Segmenta abdominis polita linea punctorum piligera postmediana prædita, pilis ad latera in fasciculus aggregatis. Pectus dense flavo-pilosum; tibiæ anteriores bidentatæ, dente basali in utroque sexu perparvo; antennæ fusco-rufæ clava quam stipes in utroque sexu brevior.

♂ Long. 14, lat. 8; ♀ Long. 16.5, lat. 8-8.5 mm.

LUZON, Manila and Dolores, P. I.

Die drei mir vorliegenden Stücke sind in der Färbung verschieden. Das eine ist satt erzgrün, das zweite hell bronzefarben, das dritte satt kupferbraun, alle mit starkem Messingglanz. Die Sculptur der Flügeldecken ist fast diesselbe wie bei der *sulcatula*, aber alle Erhabenheiten auf diesen, die Rippen und Rippenhöcker erscheinen wie abgeschliffen und man erblickt auf den glatt polierten Flügeldecken unter der Lupe nur noch feine Punktreihen, die primären Punktreihen; im subsuturalen Interstitium zwei regelmässige Punktreihen und dazwischen von der Basis bis zur Mitte unregelmässige Punktierung, im zweiten Interstitium zwei regelmässige Punktreihen, ebenso im dritten, zwischen die sich aber auf den breiten Schultern und auf den Spitzenbuckeln wieder unregelmässige Punkte schieben; auch die Punktreihe auf der zweiten primären Rippe ist vorhanden. An den Seiten haben alle drei Stücke einige grobe Querrunzeln. Ganz eigentümlich ist der Forceps gebaut. Die Parameren sind symmetrisch und jede mit einem grossen zahnartigen Fortsatz in der Mitte der Innenseite versehen; die Ventralplatte des Mittelstückes trägt zwei symmetrische Fortsätze, die löffelartig ausgehöhlt sind.

Anomala catenatopunctata sp. nov.

Ex affinitate *A. exaratae*. Ovata, convexa, saturate viridi-ænea, polita, interdum aureo splendore suffusa. Clipeus trapezoidalis angulis vix rotundatis margine elevato, cum fronte dense confluentur et rugose punctatus, vertice ad oculos præcipue dispersius et grossius punctato. Thorax lateribus medio paulo ampliatus a basi antice versus gradatim angustatus sicut vertex et scutellum disperse profunde punctatus, sulculo basali medio non interrupto. Elytra pone humeros prominentia impressa profunde sulcato-striata et in sulcis punctata, punctis circumvallatis confluentibus, costis et interstitiis æqualiter alte elevatis. Pygidium dense aciculatum et rugulosum lateribus sparsim hirsutum. Segmenta abdominis linea simplici piligera prædita, pectus sparsim flavo-

pilosum, tibiæ anteriores bidentatæ, dente basali sat forti, antennæ fuscæ, clava ♂ stipitis longitudine, ♀ paulo brevior.

Long. ♂ 10.5, ♀ 14; lat. ♂ 6, ♀ 6.5 mm.

LUZON, Province of Bataan, Lamao, P. I. (*H. Cuzner*, collector): Province of Albay, P. I. (*J. Whitehead*, collector).

Die Flügeldecken sind tief und ziemlich breit gefurcht, die primären Rippen und Interstitien hoch gewölbt. Die Punkte in den Furchen sind, wie man bei starker Vergrößerung beobachten kann, scharf umwallt und mit einem feinen Nabelpunkt versehen; wo die Punkte dicht hintereinander stehen, verschmelzen die feinen Umwallungen vorn und hinten mit einander und es entstehen so Kettenreihen. Im ersten Interstitium stehen zwei regelmässige sekundäre Rippen; die sie trennende Punktreihe ist nahe der Basis auf eine kurze Strecke verdoppelt. Das zweite Interstitium trägt nur eine Reihe quereingedrückter Punkte und kurzer Runzeln, ebenso das dritte, in welchem die Runzeln auf der Schulter, die flachen, zumeist einfachen Punkte weiterhin stehen; das vierte und fünfte Interstitium ist einfach gewölbt, ohne Punktreihen. Die beiden ♂ aus Bataan sind hell erzgrün, das ♀ aus Albay etwas blaugrün, auch ist seine Sculptur etwas feiner und flacher.

Anomala vietipennis sp. nov.

Anomalæ marginatæ Fabr. primo visu similis. Oblongo-ovata, convexa fusco-viridis ænea, interdum cupreo splendore suffusa, sat nitida. Clipeus trapezoidalis brevis, margine anteriore elevato, dense confluentur punctatus; sutura frontalis vix perspicua, frons confluentur, vertex disperse punctata. Thorax transversus basi nullo modo marginatus parum convexus, ad latera medio paulo dilatatus, angulis posticis obtusis non rotundatis, anticis acutis sat productis, foveola laterali instructus, cum scutello punctis circumvallatis et in fundo umbilicatis, ad latera hic illic confluentibus dense obtectus. Elytra sat late at non profunde sulcata et in sulcis punctata, punctis circumvallatis et umbilicatis, præterea tota superficie punctis minimis disperse obtecta, margine laterali incrassato sparsim breviter setosa. Pygidium cum propygidii parte posteriore dense aciculatum, undique sparsim et breviter hirsutum. Segmenta abdominis linea punctorum piligerorum simplici instructa, pilis ad latera densioribus; pectus sat dense breviter flavo-pilosum. Tibiæ anticæ bidentatæ, dente basali brevi acuto. Antennæ fuscæ clava testacea quam funiculus brevior.

Long. 13.5, lat. 7.5 mm.

LUZON, Manila, P. I. (*P. G. Woolley*, collector).

Die Flügeldecken sind breit, aber nicht tief gefurcht, die Rippen und Interstitien ziemlich hoch gewölbt, die Grübchenpunkte in den Furchen scharf umwallt und im Grunde meist fein genabelt. Dadurch, dass die Umwallung dieser Grübchenpunkte nach hinten vielfach verlischt und sich parabolisch nach den Seiten erstreckt, erscheinen die Flügeldecken

wie verrunzelt, ein Eindruck, der durch die vielen feinen Pünktchen auf Rippen und Interstitien noch verstärkt wird. In den discalen Interstitien stehen je zwei, in den lateralen je eine secundäre Rippe, im subsuturalen Interstitium zwischen den beiden secundären eine bis etwa zur Mitte reichende unregelmässige tertiäre. Die drei mir vorliegenden ♂ sind in der Färbung etwas verschieden, das eine ist rein erzgrün, das andere mehr kupfrig, beim dritten scheinen die Flügeldecken gelbbraun durch.

Anomala noctivaga sp. nov.

Præcedenti proxime affinis, differt clipeo et antennarum clava longioribus, elytris costis planioribus quasi transversim aciculatis. Oblonga, convexa, fusco-testacea viridi-ænea parum nitida. Clipeus trapezoidalis longior marginibus infuscatis sat alte elevatis, dense conflueret circumvallato-punctatus; sutura frontalis arcuata infuscata, frons dense et conflueret, vertex disperse punctata. Thorax parum convexus basi non marginatus lateribus a basi ad medium parallelis angulis posticis rectis haud rotundatis, antice sat angustatus angulis anticis acutis minus productis, lateribus conflueret, medio dispersius punctatus. Elytra fere parallela postice vix ampliata indistinctius sulcata costis evanescentibus subtiliter at dense transversim rugulosa et aciculata, tota superficie subtilissime punctulata. Pygidium grossius transversim aciculatum. Elytrorum margo incrassatus, pygidium, segmentorum abdominalium linea punctorum setis sat longis distantibus flavidis obsita, pectus densius hirsutum. Antennæ testaceæ clava quam funiculus longiore; oculi magni globosi; tibiæ anticæ sat fortiter bidentatæ.

♂ Long. 12.5, lat. 6.5-7 mm.

BATANES ISLANDS, P. I. (*R. C. McGregor*, collector).

Kleiner und relativ schlanker als die vorhergehende Art, braungelb mit grünem Erzschimmer, wenig glänzend, die Seiten der Flügeldecken, die Afterdecke, die Punktreihen der Bauchringe mit ziemlich langen gelben abstehenden Borsten besetzt. Die Flügeldecken sind seicht gefurcht, die Rippen und Interstitien flach gewölbt, die Punkte in den Furchen nur selten mehr rings unwallt, meist geht die Umwallung als feine, hinten scharf abfallende Querrunzel oder als querer Nadelriss auf die Rippen über. Die blässere Färbung, die abstehenden Borsten, die grossen Augen und lange Fühlerkeule sprechen für die nächtliche Lebensweise dieser Art.

Anomala camarinensis sp. nov.

Ovata, sat depressa, fusco-testacea. Clipeus transversus lateribus parallelis angulis vix rotundatis margine anteriore solum elevato, dense rugulosus, parum nitidus, cum fronte et vertice fuscus viridi-æneus; sutura frontalis arcuata, frons dense rugulose, vertex paulo sparsius punctata. Thorax medio dilatatus lateribus postice arcuatis angulis posticis rectis paulo productis, antice lateribus valde convergentibus,

angulis anticis rectis non productis, sulculo basali nullo, undique dense et grosse, lateribus confluentur circumvallato-punctatus, cum scutello aequaliter punctato fusco-viridis haud aenescens, lateribus testaceis. Elytra sat late et profunde sulcata costis sat convexis in sulcis fortiter punctata et tota superficie punctis minoribus disperse obtecta. Pygidium medio fuscum paulo elevatum ibique subtilius punctatum lateribus testaceis rude ac grosse confluentur punctatum, circa anum setis rufis longioribus instructum. Segmenta abdominis glabra ad latera solum sparsissime pilosa, pectus vix vel non hirsutum. Tibiae anticae breviter bidentatae, antennae rufo-testaceae, clava stipitis longitudine. Supra cum femoribus testacea, tibiae posticae tarsisque cuprascentes.

Long. ♂ 14, ♀ 15.5; lat. ♂ 8, ♀ 8.5 mm.

Luzon, Province of Camarines, P. I., 10–13 Juni, 1903 (*H. Hallier*, collector).

Die Flügeldecken sind ziemlich tief und breit gefurcht, in den Furchen stehen dichte Reihen von umwallten hufeisenförmigen, nach hinten offenen Punkten ausserdem ist die ganze Oberfläche mit feineren Pünktchen übersät. Alle Interstitien haben zwei sekundäre Rippen, die an den Seiten dicht neben einander verlaufen, stellenweise nur schwach getrennt sind, auf der Scheibe dagegen durch einen breiten Zwischenraum, in dem sich auf dem subsuturalen Interstitium Stücke einer tertiären Rippe zeigen. Eigenartig ist der Bau des Pygidiums, das in der dunkler gefärbten Mitte mit feinen, scharf unwallten Punkten bedeckt ist, während die gelben Seiten auffallend grob und runzelig punktiert sind.

Anomala schultzeana sp. nov.

Ovata, parum convexa, robusta, testacea capite, thorace marginibusque plus minus fuscata, interdum aenescens, supra glabra, subtus cum pygidio pilis longis flavidis vestita.

Long. ♂ 11, ♀ 13; lat. ♂ 6, ♀ 7.5 mm.

Luzon, Manila, P. I. (*W. Schultze*, collector).

Diese Art bildet gewissermassen den Übergang von der Untergattung *Anomala* (*sensu stricto*) zu *Aposterna*. Sie ist greit oval, flach gewölbt, ihre Farbe ist hell scherbengelb, zuweilen mit leichtem grünem Metallschimmer, der Kopf und die hintere Hälfte des Kopfschildes, eine grössere oder kleinere Makel auf dem Halsschild, zuweilen auch das Schildchen und die Ränder der Flügeldecken sind braunschwarz. Das Kopfschild ist um die Hälfte breiter als lang, die Seiten parallel, die Ecken schwach gerundet, der Rand deutlich aufgebogen. Das Halsschild ist vor der Mitte verbreitert, nach vorn stark verschmälert, die Vorderecken vorgezogen, die Hinterecken nahezu rechtwinklig, der Hinterrand etwas nach hinten geschwungen, die basale Randfurche deutlich, aber in der Mitte unterbrochen; Kopf, Vorderrücken und Schildchen dicht, aber ziemlich fein punktiert. Die Flügeldecken tragen regelmässige, seichte, aber scharf eingedrückte Streifen mit Punktreihen

(primäre Punktreihen), alle Interstitien sind unregelmässig ziemlich kräftig punktiert und ausserdem ist die ganze Oberfläche mit feinen Pünktchen dicht übersät. Afterdecke in beiden Geschlechtern gewölbt, dicht und fein quernadelrissig mit kleinen Höckerchen, von deren Grund lange gelbgraue Borsten entspringen. Die Vorderschienen sind mit einem kräftigen Seitenzahn versehen, die Mittel- und Hinterschienen sowie die zumeist erzgrünen Tarsen mit einzelnen langen Borsten besetzt; die Fühler rötlichgelb.

Anomala planata Candèze. Von dieser Art habe ich ausser den drei typischen Exemplaren aus der Candèze'schen Sammlung noch etwa ein halbes Dutzend gesehen, darunter nur ein ♀. Alle diese Stücke sind in Färbung und Sculptur ganz konstant. Die Hauptunterschiede gegenüber der vorhergehenden Art liegen in der feineren Punktierung auf Kopf, Thorax und Schildchen, der verloschenen Sculptur der Deckflügel, die keine Spur von Furchen oder Streifen mehr zeigen, nur noch unter der Lupe sichtbare Punktreihen und vereinzelte feine Pünktchen, und in der wesentlich größeren Skulptur der Afterdecke, die auf dunkel erzgrünem Grunde zwei rotgelbe, V-förmig gestellte Makeln trägt; die Schienen sind immer kupferrot, lebhaft glänzend, die ganze Oberseite hell erzgrün, die vordere Hälfte des Kopfschildes, die Seiten des Halsschildes und die Flügeldecken, mehr oder weniger gelb durchscheinend. Die ♂ messen zumeist 12×7 , mein ♀ 14.5×8.5 mm.

Anomala andradei Heller ist eine auf der Oberseite violette *planata*, bei welcher der Rand des Kopfschildes und die Seiten des Halsschildes rotgelb gefärbt sind; die Unterseite ist erzgrün, Schenkel und Schienen kupferrot, die Tarsen dunkler kupferbraun, der Hinterrand der Bauchringe scheint gewöhnlich, die zwei schiefgestellten Makeln auf der Afterdecke, seltner rotgelb durch. Die Sculptur ist wie bei der *planata*, auf den Flügeldecken treten neben der Schulter-Spitzenbuckel-Linie zuweilen die feinen Querrunzeln auf, die für die *chalybæa* und *corruscans* so charakteristisch sind; auch sind die Seiten der Flügeldecken hinten beim Aussenwinkel ebenso nadelrissig. Ob beide Arten zusammenfallen, lässt sich erst entscheiden, wenn grösseres Material vorliegt—von der *andradei* kennt man bisher nur ♂—und wenn man die Fundorte und Erscheinungszeit beider Arten erforscht hat; für beide liegt bisher nur die Fundortsangabe „Philippinen“ resp. Luzon vor, nur für mein ♀ der *planata* habe ich den genaueren Fundort.

Luzon, P. I., 5–6000 feet (*J. Whitehead*, collector).

Anomala (*Aprosterna*) *heteroglypha* sp. nov.

Anomala chalybæa Burm. proxime affinis, differt longitudine, sculptura et plerumque colore, praecipue autem sexuum difformitate. ♂ ovatus, parum convexus, aut testaceus, plus minusve fusco-viridi-signatus,

viridi-æneo sive violaceo-splendore suffusus, aut fusco-viridis æneus, politus. Caput, thorax, et scutellum subtiliter ac disperse, interdum vix perspicue punctulata; elytra in disco plerumque politissima, ad latera solum punctato-seriata et irregulariter disperse, pone angulum exteriorem confluentem densius punctulata, rarius in disco quoque seriato-punctata et inter series punctorum majorum irregulariter subtilius punctulata. Pygidium dense transversim aciculatum et confluentem punctato-rugulosum. ♀ plerumque gracilior, i. e. postice minus ampliata, magis convexa, aut viridi-ænea, aut cuprea, aut violacea, aut nigra. Caput, thorax et scutellum punctis magnis singulis circumvallatis oblecta; elytra regulariter et sat fortiter punctato-seriata, inter series haud punctulata, rarius punctis in disco evanescentibus. Pygidium punctis magnis profundis plerumque singulis, rarius confluentibus dense obsitum.

♂ Long. 9.5–11.5, lat. 6–6.5; ♀ long. 12.5–14, lat. 6.5–7 mm.

LUZON, P. I.

Aus einer grösseren Suite, die mir ein Händler vor Jahren mit dem Fundort „Luzon“ zuschickte, suchte ich mir 5 ♂ und 5 ♀ aus, alle verschieden. Die Art ist ungemein variabel in der Färbung; beim ♂ lassen sich folgende Färbungen unterscheiden, 1.) ähnlich wie eine kleine *planata*, hell scherbengelb mit lebhaftem grünem Erzschilder, zwei schiefe Streifen auf dem Kopfschild, der Kopf, das Halsschild mit Ausnahme des breiten Seitenrandes, das Schildchen, auf den Flügeldecken die Partie um das Schildchen, die Naht und der Aussenwinkel, die Afterdecke mit Ausnahme von zwei schiefen Makeln bei der Spitze, unten die Brust und der Vorderrand der Bauchringe dunkel erzgrün, die Schienen und Tarsen kupfrig. 2.) sonst wie 1.) nur die Flügeldecken rein rötlich-gelb mit lebhaftem violetttem Schiller. 3.) oben erzgrün, die Seiten des Thorax, eine Makel auf der Scheibe der Flügeldecken, die zwei schiefen Makeln auf der Afterdecke, unten die Seiten der Bauchringe gelb durchscheinend, die Beine ganz kupferrot. 4.) oben hell erzgrün, die Flügeldecken blaugrün, unten wie 3.) also die Seiten der Bauchringe stets gelb, die Beine kupferrot. Vom ♀ liegen mir folgende Färbungen vor, 1.) hell erzgrün oben und unten, ohne Spur von gelb. 2.) ebenso dunkel erzgrün. 3.) erzgrün mit kupfrigen und gelben Reflexen, die Deckflügel leuchtend kupferrot. 4.) blaugrün, die Deckflügel violett. 5.) oben und unten gleichmässig glänzend schwarz. Die ♂ lassen sich, abgesehen von Grösse und Färbung, leicht durch die feine Sculptur auf dem Vorderkörper und die zumeist ganz verloschene Punktierung auf den Deckflügeln von den anderen Arten der Gruppe unterscheiden; auch die ♀ wird man wohl nicht mit denen der *chalybæa* verwechseln, weil sie—abgesehen von der geringeren Grösse und schlankeren Form—wohl eine kräftige Punktierung auf Kopf, Thorax und Flügeldecken, dagegen viel weitläufigere, mehr vereinzelte Punktierung auf der Afterdecke haben und weil ihnen die Querrunzeln auf den Flügeldecken fehlen. Beim ♂

sind die Flügeldecken am Seitenrand beim Aussenwinkel, da wo der Seitenrand zum Hinterrand umbiegt, dicht gerunzelt und nadelrissig—wie bei der *planata* und *andradei*—beim ♀ nicht.

Anomala chalybaea Burm. unterscheidet sich von den vorhergehenden Arten durch die grobe Sculptur von Kopf und Kopfschild, die Furchen auf den Flügeldecken hinten zwischen Naht und Spitzenbuckel und die Längsreihe von kurzen Querrunzeln zwischen Schulter und Spitzenbuckel. Zu den bekannten Varietäten kommt noch folgende: „Hell erzgrün, oben die Seiten des Halsschildes, die ganze Unterseite, Afterdecke und Beine rötlichgelb, nur die Tarsen braungrün.“

Anomala relucens Har. pro *polita* Blanch., Cat. Coll. Ent. (1850) 196. ist synonym zur *A. chalybaea* Burm., wie ich durch Untersuchung der Blanchard'schen Typen aus dem Pariser Museum feststellen konnte.

Anomala corruscans Chevr. Die Körperfarbe ist zumeist ein helles Erzgrün. Ganz vereinzelt finden sich Stücke, bei denen die Oberseite, zumal auf den Deckflügeln schön kupferbronzefarben gefärbt ist—var. *cuprea* Ohs. Ein auffallend kleines, nur 14 mm. langes Stück mit stark verloschener Sculptur erhielt ich von PALAWAN (*G. Semper* dedit).

***Anomala (Euchlora) inconsueta* sp. nov.**

Oblonga, postice vix ampliata, fusco-viridis aenescens, elytra graminea certo visu rufescentia, tibiae cum tarsis rufo-cuprea, antennae rufo-testaceae, supra cum pygidio dense confluentur punctulata, subsericea, pygidio et pectore sat dense ac longe vulpino-pilosa. Clipeus transversus lateribus parallelis angulis paulo rotundatis margine anteriore paulo elevato anguste cupreo deinde fusco-limbato, dense ac confluentur punctis circumvallatis et umbilicatis obtectus; sutura frontalis recta, frons sicut clipeus, vertex dispersius et postice subtilius punctata.

♂ Long. 22–24, lat. 11.5–12 mm.

Variat tota rufobrunnea.

NEGROS, P. I., März, April, 1896 (*J. Whitehead*, collector); LUZON, Province of Benguet, P. I. (*R. C. McGregor*, collector).

Eine ganz eigentümliche Form, zu der mir keine Parallele aus der indomalayischen Region bekannt ist, die dagegen beim ersten Anblick lebhaft an gewisse grüne Anomalen des west- und centralafrikanischen Faunengebietes erinnert. Die Körperform ist gestreckt, die Flügeldecken nahezu parallel, nicht nach hinten verschmälert wie die meisten Euchloren. Die Farbe ist ein mässig dunkles Erzgrün mit leicht seidartigem Glanz, die Flügeldecken grasgrün mit rotem Schimmer bei bestimmter Beleuchtung; zuweilen ist der ganze Käfer rotbraun. Der Kopf ist mässig gross, das Kopfschild rechtwinklig mit schwach gerundeten Ecken, der Vorderrand leicht aufgebogen, mit schmalem kupfrigen

und darauf schwarzem Randsaum; die Fühler sind gross, die Keule so lang als die Geissel, braungelb mit leichtem Erzschilder. Die ganze Oberfläche ist mit umwallten und im Grunde fein genabelten Punkten dicht bekleidet, die auf Kopfschild und Stirn sowie an den Seiten des Halsschildes vielfach zusammenfliessen. Auf den Flügeldecken ist von der primitiven Sculptur nur noch die erste primäre Punktreihe (neben der Naht) erhalten, die ganze Oberfläche ist mit umwallten, bald kreisförmigen, bald hufeisenförmigen Punkten übersät, während das Gewebe zwischen ihnen sich vielfach zu kleinen Querrunzeln erhebt. Die Afterdecke ist relativ kurz, an der Spitze breit zugerundet und im Spitzenteil mit langen gelben Haaren bekleidet; auch neben den Augen, am Seitenrand des Halsschildes und an der Schildchenbasis stehen lange gelbe Haare. Die Bauchringe tragen die gewöhnliche Querreihe von borstentragenden Punkten, die an den Seiten dichter zusammen stehen, Vorder- und Hinterbrust sind dicht und lang rotgelb behaart, die Vorderschienen zweizählig.

Anomala (Euchlora) præmatura sp. nov.

Elliptica, antice et postice aequaliter fere acuminata, fusco-cupreo-aenea thoracis lateribus, coxis, femoribus antennisque testaceis, caput, thorax et scutellum dense punctata, sat nitida, elytra densissime confluentur punctatis subsericeis.

♂ ♀ Long. 16.5–18, lat. 9–10 mm.

Luzon, P. I., 5–6000 feet; Province of Albay, P. I.; NEGROS, P. I., März, April, 1896 (*J. Whitehead*, collector).

Vom richtigen Euchlorentypus, elliptisch, nach vorn und hinten nahezu gleichmässig verschmälert, glänzend wie Kupferbronze, der Vorderkörper etwas heller, die Flügeldecken etwas dunkler und matter, die Seiten des Halsschildes, die Hüften und Schenkel sowie die Fühler rötlichgelb. Das Kopfschild ist breiter als lang, rechtwinklig mit leicht gerundeten Ecken, der Rand ganz schwach aufgebogen, die Fläche wie die Stirn dicht und fein runzelig, während der Scheitel einzeln zerstreut punktiert ist. Das Halsschild ist wie der Scheitel punktiert, doch stehen die Punkte an den Seiten wie gewöhnlich etwas dichter, die basale Randfurche ist in der Mitte breit unterbrochen. Das Schildchen ist zerstreut fein punktiert. Auf den Flügeldecken sind die primären Punktreihen an der Seite und neben der Naht erhalten, alles übrige ist untergegangen in einer äusserst dichten feinen Punktierung, die auch zum Teil auf die Nahtrippe übergeht; der Seitenrand ist rippenartig scharf abgesetzt. Die spitze Afterdecke ist dicht nadelrissig, mässig glänzend und ganz spärlich kurz behaart. Glänzender als die Oberseite ist die Unterseite, zumal die nahezu kahlen Bauchringe und Beine, während die Brust an den Seiten dichter punktiert und dünn behaart ist. Die Vorderschienen sind kräftig zweizählig, die Fühlerkeule bei

♂ und ♀ gleich lang, kürzer als die Geißel. Bei unreifen Stücken sind auch die Epimeren der Mittel- und Hinterbrust, zuweilen sogar die Bauchringe gelb und die rotgelb durchscheinenden Flügeldecken haben einen opaleszierenden blauen Schiller.

Anomala (Euchlora) baeri sp. nov.

Præcedentis magnitudine et statura, tota fusco-cupreo-ænea segmentis abdominalibus solum ad latera rufomaculatis, minus nitida, dense confluentur punctata, elytris præterea transversim aciculata.

♂ ♀ Long. 17–19, lat. 10–10.5 mm.

LUZON, Province of Albay, P. I. (*J. Whitehead*, collector); Manila, P. I. (*G. Baer*, collector); NEGROS, P. I., März, April, 1896 (*J. Whitehead*, collector); SAMAR, P. I., Juni, Juli, 1896 (*J. Whitehead*, collector).

Der vorhergehenden Art zunächst verwandt, aber gleichmässig dunkler bronzefarben ohne erzgrüne Reflexe, nur an den Bauchseiten mit einigen rotgelben Fleckchen. Der ganze Käfer hat schwachen seidenartigen Glanz in Folge der dichten und feinen, vielfach zusammenfließenden Punktierung. Die Flügeldecken tragen an Stelle der primären Punktreihen zuweilen ganz feine Streifen oder Furchen und sind, zumal an den Seiten dicht mit querverlaufenden feinen Nadelrissen bedeckt, die durch das Zusammenfließen von umwallten und hufeisenförmigen Punkten entstanden. Die basale Randfurche auf dem Thorax fehlt ganz, ebenso zuweilen der basale Zahn an den Vorderschienen, beim ♂. Die Forcepsparameren, bei der vorhergehenden Art von der Basis bis zur Spitze gleichmässig verschmälert, sind hier in der Mitte auffallend verbreitert und mit der Spitze nach unten gebogen.

Anomala (Euchlora) chloropyga Burm. Neben den Stücken mit hell- oder olivengrüner Oberseite und schwachem Erzschimmer finden sich auch solche, bei denen die Oberseite bronzefarben ist, solche mit rotem bis violettem Schiller. Gewöhnlich ist die Afterdecke rein gelb, seltener tritt auf der Mitte des Vorderrandes ein braungrüner dreieckiger Fleck auf, der in einzelnen Fällen, zumal beim ♀ bis zur Spitze der Afterdecke reicht.

MIMELA Kirby.

Mimela palawana sp. nov.

Mimela xanthorrhina Hope similis. Parva, ovata, alte convexa, flavotestacea abdomine infuscato, viridi-ænea, elytra sola viridi-pomacea, antennæ flavotestacea.

♂ ♀ Long. 11–12, lat. 6.5–7 mm.

PALAWAN, Bacuit, Mt. Capoas P. I. (*C. M. Weber*, collector).

Vom Aussehen einer kleinen *M. xanthorrhina*, hell scherbengelb mit lebhaftem grünem Erzschiller, Brust und Bauch etwas dunkler, die Flügeldecken schön apfelgrün, die Fühler gelb. Das Kopfschild wie

bei den meisten Arten der Gattung breiter als lang mit parallelen Seiten und schwach gerundeten Vorderecken, der ganze Vorderkörper, Kopf, Halsschild und Schildchen mässig dicht und mässig stark punktiert. Flügeldecken mit regelmässigen, nicht furchenartig vertieften, primären Punktreihen; die Interstitien ziemlich weitläufig punktiert. Afterdecke beim ♂ mässig dicht und zerstreut, beim ♀ gröber und dichter punktiert, nur am Rande mit einzelnen Borsten. Bauchringe und Brustseiten ziemlich dicht und grob sculptiert, die letzteren spärlich behaart, Mittelbrust ohne Vorsprung, Vorderbrust mit grosser, unten abgeflachter Lamelle. Vorderschienen mit kräftigem Seitenzahn neben dem Spitzenzahn, die Mittel- und Hinterschienen leicht wadenartig verdickt; Fühlerkeule beim ♂ um die Hälfte länger, als beim ♀.

MALAIA Heller.

Malaia thoracica sp. nov.

Magnitudine et statura *M. ornata* Schaaf., crassa, supra sat deplanata, capite, thorace scutelloque sat laete viridi-aeois, elytris nigris plaga magna rufa ornatis, subtus cum pedibus obscurius fusco-viridi-aeois hic illic cuprascens, supra thorace solum sparsim griseo-hirsuta, subtus cum pygidio albo-flavido-squamosa.

♂ Long. 9.5, lat. 5.5 mm.

Luzon, P. I. (*J. Whitehead*, collector).

Von der Grösse und Körperform eines grossen ♀ der *M. ornata*, Kopf, Thorax und Schildchen ziemlich hell erzgrün, die Flügeldecken glänzend schwarz mit einer grossen rotgelben Makel, die neben der Schulter von der Basis bis zum Hinterrand reicht, Afterdecke, Unterseite und Beine sind dunkler erzgrün mit kupfrigen Reflexen. Kopfschild trapezoidal mit leicht aufgebogenem Rand, dicht nadelrissig, seidenartig glänzend, vorn kupfrig; der Kopf ebenso dicht quernadelrissig, die Stirn breit dreieckig abgeflacht. Das Halsschild ist dicht quernadelrissig, nur an den Seiten sind diese Nadelrisse in einzelne Punkte aufgelöst und an dem Hinterrand steht beiderseits ein länglicher dreieckiger ganz glatter, kupfrig glänzender Fleck, der sich von dem matt seidenartigen Teil des Thorax scharf abhebt; nur am Seitenrand und bei den Vorderecken stehen einzelne spärliche graugelbe kurze Härchen. Schildchen ziemlich dicht punktiert mit glatter Mitte. Flügeldecken mit stark vorspringenden Schultern, abgeflacht oben, mit regelmässigen seichten Furchen und Punktreihen darin, innen neben der Schulter und hinter dem Schildchen leicht eingedrückt. Afterdecke hochgewölbt, mit Hufeisenpunkten, die vielfach zu bogigen Strichen zusammenfliessen, mit zwei geschwungenen langen Makeln von gelben Schuppenhaaren. Bauchringe mit doppelten Querreihen von gelben Schuppenhaaren, die vordere Reihe spärlich und seitlich verkürzt, die hintere dichter und an den Seiten zu kleinen Makeln verbreitert. Brust in der Mitte kahl, an den Seiten spärlich mit Schuppenhaaren bekleidet, ebenso die Beine ziemlich

spärlich behaart. Hinterbrust vorn breit zwischen den Mittelhüften; darauf setzt sich ein nach hinten halbkreisförmiger Fortsatz der Mittelbrust, der von der Seite gesehen, als feine kurze Spitze schief nach unten vorspringt. Hinterbeine sehr kräftig, Mittel- und Vorderbeine schwach, Vorderschienen zweizählig die Tarsen kurz und dünn, die grössere Klaue vorn beim ♂ kaum verdickt.

POPILLIA Serville.

Popillia mcgregori sp. nov.

P. conopyga Ohs. proxime affinis: Supra cum tibiis tarsisque viridivirena, nitida, subtus cum pygidio, femoribus et antennis rufo-testacea, deplanata, pygidio parum descendente fortiter acuminato lateribus sparsim flavo-hirsuto, haud fasciculato.

♂ Long. 9.5, lat. 5.5 mm.

Luzon, Province of Benguet, Pauai, P. I. (*R. C. McGregor*, collector).

Eine kleine, auffallend stark abgeflachte Form. Die Oberseite, die Schienen und Tarsen sind glänzend erzgrün, die Afterdecke, Unterseite, Schenkel und Fühler rotgelb. Das Kopfschild ist trapezförmig, vorn gerade abgestutzt und hier so breit wie lang, der Rand schwach aufgebogen; die Stirnnaht gerade, leicht erhaben, der ganze Kopf grob runzelig punktiert. Das Halsschild ist von der Basis nach vorn stark verschmälert, die Seiten vor der Mitte winkelig gebogen, von diesen Winkel nach vorn stark convergierend, die Vorderwinkel kräftig vorspringend, von dem Winkel nach hinten und nach innen geschwungen, die Hinterwinkel scharf vorspringend, die Mitte mit kräftiger Längsfurche und schwachen schiefen Eindrücken von der Mitte nach den Vorderwinkeln, die Oberfläche mit tiefen Punkten bedeckt, die vielfach zu kurzen Furchen zusammenfliessen. Schildchen relativ gross, zerstreut mässig stark punktiert. Flügeldecken stark abgeflacht, in der Mitte verbreitert, wesentlich breiter als das Halsschild, mit vorspringenden Schultern- und Spitzenbuckeln, die Naht verkürzt, regelmässig und tief gefurcht; Rippen und Interstitien gewölbt, im ersten und zweitem je zwei secundäre Rippen; im dritten, (zwischen Schulter und Spitzenbuckel) nur eine, an den Seiten die Sculptur undeutlich. Afterdecke nur wenig nach unten gesenkt, scharf zugespitzt, leicht quernadelrissig und mit Ausnahme der Mitte überall mit kurzen graugelben Härchen bekleidet. Bauchringe und Brust dicht graugelb, behaart, der Mesosternalfortsatz hoch, mässig vorspringend. Vorderschienen mit kräftigem Seitenzahn, die grössere Klaue an allen Füssen stark verlängert und verdickt, vorn und in der Mitte nur ganz schwach eingeschnitten.

Popillia scalpta Newm.

Herr, G. J. Arrow vom British Museum hat in den *Trans. Ent. Soc. London*, (1899) p. 272 die *Pop. amula* Newm. wie auch die *Pop. picticollis* Kraatz als Synonyme zur oben genannten Art gestellt. Da die *Pop.*

picticollis Kraatz und die *Pop. amula* Newm. im Sinne von Kraatz in dessen Sammlung fraglos zwei verschiedene Arten sind, so schickte ich meine Stücke, nachdem ich sie mit denen in der Kraatz'schen Sammlung sorgfältig verglichen, an Herrn Arrow mit der Bitte, sie mit der Newman'schen Type nochmals zu vergleichen was er in gewohnter liebenswürdigster Weise umgehend erledigte. Hierbei ergab sich, dass die *picticollis* Krtz. sicher synonym zur *scalpta* Newman, die *amula* Newman im Sinne von Kraatz aber eine neue Art ist. Es liegen mir von dieser Form zwei ♂ und vier ♀ vor, die sich von den mir vorliegenden fünf ♂ und vier ♀ der *scalpta* in folgenden Punkten unterscheiden:

Popillia oculata sp. nov.

Magnitudine et statura *P. scalptæ* Newm.; tota nigra, nitida, differt thorace politissimo, sub lente vix perspicue punctulato et margine sparsim albido-squamoso, macula elytrorum flavida postscutellari semper circulari, parva.

Long. 9.5–11, lat. 5.5–6 mm.

Luzon. (*C. Semper, J. Whitehead*, collectors).

Kopfschild und Kopf sind seichter und zerstreuter punktiert, als bei der *scalpta* Newm. Das Halsschild ist in seiner mittleren und hinteren Partie glänzend poliert, punktfrei, vorn ist es fein punktiert, die Punkte nach den Vorderecken hin kräftiger und dichter werdend; die Schuppenhaare sind im Allgemeinen etwas mehr gelblich als bei der *scalpta*, am Seitenrand ganz spärlich, beim ♀ vielfach fehlend, am Hinterrand nur vom Hinterwinkel bis halbwegs zum Schildchen reichend, immer stärker als an den Seiten, am Vorderrand nur einige wenige (vier bis fünf) Borsten, neben den Vorderecken; das Seitengrübchen meist sehr gross. Schildchen gross, stets frei von Punkten und Schuppen. Flügeldecken schwarz., seltener schwarzbraun, mit einer kleinen kreisrunden rotgelben Makel hinter dem Schildchen. Der Querstreifen von Schuppenhaaren am Hinterrand des Propygidiums und die 4 Makeln auf dem Pygidium dünn und spärlich, die Schuppenhaare im einzelnen auch feiner als bei der *scalpta*. Die Parameren des Forceps sind symmetrisch, bei der *scalpta* nach der Spitze hin gleichmässig verschmälert, bei der *oculata* mit zwei kräftigen Zähnen, die rechtwinklig zur Längsachse des Organes an der Spitze seitlich vorspringen.

Popillia cetrata Newm. ist von den beiden vorhergehenden Arten leicht zu unterscheiden durch ihre erzgrüne Grundfarbe und das beschuppte Scutellum. Die Art scheint in der Färbung ziemlich variabel zu sein; von den drei mir vorliegenden ♀—den ♂ kenne ich noch nicht—hat das eine hellgelbe Flügeldecken mit leichtem grünem Erzschilder und ganz schmalem grünem Saum an Schulter und Seitenrand, das zweite dunklergrüne Flügeldecken mit einem unbestimmten grossen rotgelben Längswisch von der Basis bis nahe an den Hinterrand, das dritte schwarze,

erzgrün schillernde Flügeldecken. Die Schuppen sind bald mehr gelb und dann breit und dicht, bald weisslich und dann etwas dünner. Auf dem Halsschild ist die Mitte der Länge nach leicht gewölbt, daneben beiderseits vom Vorderwinkel bis nahe an die Schildchenecken eine schiefe Furche, diese bald tief, bald flach und dann nahe dem Anfang schon verlöschend; in dieser Furche stehen ebenso wie am Seitenrand, Hinterrand und Vorderrand, mit Ausnahme der Mitte, dicht gedrängte Schuppenhaare. Die Afterdecke trägt vier kräftige Schuppenflecke, die zuweilen in zwei Längsstreifen vereinigt sind.

LISTE DER RUTELIDEN DER PHILIPPINISCHEN INSELN.

I. ANOMALINI.

ANOMALA Samuelle.

Ent. useful Compend. (1819) 1, 191.

Subgenus **Rhinoplia** Burmeister.

Handb. (1844) IV, 1, 232.

1. **A. infans** Ohs. sp. nov.

LUZON, P. I. (*C. Semper*, collector).

Subgenus **Heteroplia** Burmeister.

Handb. (1844) IV, 1, 233.

2. **A. flavoscutellata** Ohs. sp. nov.

LUZON, Province of Cagayan, Cape Engaño, P. I. (*J. Whitehead*, collector).

3. **A. macrophthalma** Ohs. sp. nov.

LUZON, Province of Cagayan, Aparri, P. I. (*R. C. McGregor*, collector).

Subgenus **Anomala** Samuelle.

In species sec. Burm. Handb. IV, 1, 246.

4. **A. camarinensis** Ohs. sp. nov.

LUZON, Camarines, P. I., 10–13 Juni, 1903. (*H. Hallier*, collector).

5. **A. catenatopunctata** Ohs. sp. nov.

LUZON, Province of Albay, Albay, P. I. (*J. Whitehead*, collector); Province of Bataan, Lamac, P. I. (*H. Cuzner*, collector).

6. **A. despumata** Ohs. sp. nov.

LUZON, Manila, Dolores, P. I.

7. **A. exarata** Burm., Handb. (1844) IV, 1, 260.

LUZON, Manila, P. I.; NEGROS, P. I., März, April, 1896 (*J. Whitehead*).

8. *A. humeralis* Burm., Handb. (1844) IV, 1, 262.

eydouæii Blanch. Cat. Coll. Ent. (1850) 192.

LUZON, P. I. (*C. Semper*, *J. Whitehead*); Manila, P. I. (*Schadenberg*, *C. S. Banks*); Province of Bulacan, Quingua, P. I. (*E. Simon*); Province of Tarlac, Pura, P. I. (*M. Fernandez*); LEYTE, P. I., März, April, 1896 (*J. Whitehead*); MINDORO, P. I. Dezember 1894 (*Everett*); PALAWAN, P. I. (*C. Semper*).

9. *A. leotaudii* Blanch., Cat. Coll. Ent. (1850) 191.

LUZON, Manila, P. I. (*W. Schultze*).

Var. *fuscoviridis* Ohs.

LUZON, Province of Cagayan, Cape Engaño, P. I.

10. *A. noctivaga* Ohs. sp. nov.

BATANES ISLANDS, P. I. (*R. C. McGregor*, collector).

11. *A. ovatula* Ohs. sp. nov.

MINDANAO, Camp Keithley, P. I. (*Mrs. M. S. Clemens*, collector); LEYTE, P. I. (*J. Whitehead*, collector); PALAWAN, P. I. (*C. M. Weber*, collector).

12. *A. palawana* Ohs. sp. nov.

PALAWAN, P. I. (*C. Semper*, dedit); Bacuit, P. I. (*C. M. Weber*, collector).

13. *A. planata* Cand., Col. Hefte, (1869) V, 42.

MINDANAO, Camp Keithley, P. I. (*Mrs. M. S. Clemens*); LEYTE, P. I. August, 1896 (*J. Whitehead*); LUZON, Province of Benguet, Irian, P. I. (*R. C. McGregor*); Province of Cagayan, Lal-loc, P. I. (*H. M. Curran*).

14. *A. proctolasia* Ohs. sp. nov.

LUZON, Manila, P. I.; POLILLO, P. I. (*R. C. McGregor*, collector).

15. *A. schultzeana* Ohs. sp. nov.

LUZON, Manila, P. I. (*W. Schultze*, collector).

16. *A. semperiana* Ohs. sp. nov.

LUZON, P. I. (*C. Semper*, collector).

17. *A. sulcatula* Burm., Handb. (1844) IV, 1, 261.

LUZON, P. I. (*J. Whitehead*); Manila, P. I. (*G. A. Baer*, *C. S. Banks*, *Mrs. H. Otto*, *Schadenberg*); Province of Albay, P. I. (*J. Whitehead*); Province of Bataan, Limay, P. I. (*R. J. Alvarez*); POLILLO, P. I. (*R. C. McGregor*); PALAWAN, P. I. (*C. Semper*); Mt. Capoas, P. I. (*C. M. Weber*).

18. *A. varicolor* Gyllenh., Schönh. Syn. Ins. App. I, 3, 114.

LUZON, P. I. (*J. Whitehead*); Manila, P. I. (*W. Schultze*); MINDORO, Rio Baco, Balete, P. I. (*R. C. McGregor*); PALAWAN, P. I. (*C. M. Weber*).

19. *A. vietipennis* Ohs. sp. nov.

LUZON, Manila, P. I. (*P. G. Woolley*, collector).

20. *A. whiteheadi* Ohs. sp. nov.

LUZON, Province of Albay, P. I. (*J. Whitehead*, collector).

Subgenus *Aprosterna* Hope.

Trans. Ent. Soc. London (1835) 1, 117; Burm., Handb. (1844) IV, 1, 281.

21. *A. andradei* Heller, Ent. Nach. (1893) 323.

LUZON, Manila, P. I.; Province of Cagayan, Misiones River, P. I.

22. *A. chalybæa* Burm., Handb., (1844) IV, 1, 282.—Heller, Ent. Nachr. (1893) 321.

A. polita Blanch., Cat. Coll. Ent. (1850) 196.

A. relucens Har.

LUZON, Manila, P. I. (*Schadenberg*); Province of Benguet, Irisan, P. I. (*R. C. McGregor*); Province of Rizal, Montalban Gorge, P. I. (*W. Schultze*).

23. *A. corruscans* Chevrol., Rev. Zool. (1841) 222.—Burm., Handb. (1844) IV, 1, 282.—Heller, Ent. Nachr. (1893) 321.

LUZON, P. I. (*C. Semper*, 5–6000 feet; *J. Whitehead*); Manila, P. I. (*Schadenberg*); Province of Benguet, Baguio, P. I. (*R. C. McGregor*); Province of Abra, Bangued, P. I. (*C. S. Banks*).

24. *A. heteroglypha* Ohs. sp. nov.

LUZON, P. I.

Subgenus *Spilota* Burmeister.

Handb. (1844) IV, 1, 266.

25. *A. picturata* Cand., Col. Heftte (1869) 5, V, 42.

N. LUZON, P. I. (*C. Semper*; *J. Whitehead*); S. LUZON, P. I. (*Donckier*); CATANDUANES ISLANDS, P. I. (*J. Whitehead*); MINDORO, Balete, Rio Baco, P. I. (*R. C. McGregor*); NEGROS OCCIDENTAL, Siya-Siya, Mt. Canlaon, P. I. (*C. S. Banks*).

Subgenus *Euchlora* MacLeay.

Hor. Ent. (1819) I, 148.—Burm., Handb. (1844) IV, 1, 274.

26. *A. anoguttata* Burm., Handb. (1844) IV, 1, 280.

N. LUZON, P. I. (*J. Whitehead*); Manila, P. I., (*Schadenberg*; *M. Herzog*); LUZON, Province of Albay, Albay, P. I. (*J. Whitehead*); Camarines, P. I., 10–13 Juni, 1903 (*H. Hallier*); Province of Zambales,

- P. I., Mai, 1880 (*C. Semper*); MINDORO, P. I., November, 1895, Januar, 1896 (*J. Whitehead*).
27. *A. atrocyanea* Burm., Handb. (1844) IV, 1, 277.
LUZON, Manila, P. I.; SIBUYAN, P. I. (*R. C. McGregor*).
28. *A. baeri* Ohs. sp. nov.
N. and S. LUZON, Manila, P. I. (*G. A. Baer*, collector); Province of Albay, P. I.; NEGROS, P. I., SAMAR, P. I., Juni, Juli, 1896 (*J. Whitehead*, collector); MINDANAO, Camp Keithley, P. I. (*Mrs. M. S. Clemens*, collector); PALAWAN, Bacuit, P. I. (*C. M. Weber*, collector).
29. *A. chalcoptera* Burm., Handb. (1844) IV, 1, 281.
MINDANAO, P. I.
30. *A. chloropyga* Burm., Handb. (1844) IV, 1, 281.
N. and S. LUZON; Manila, P. I. (*Schadenberg*); Province of Albay, P. I. (*J. Whitehead*).
31. *A. dasypyga* Burm., Handb. (1844) IV, 1, 280.
LUZON, P. I.
32. *A. encausta* Cand., Col. Heft. (1869) V, 42.
LUZON, Manila, P. I.; MINDANAO, P. I.
33. *A. inconsueta* Ohs. sp. nov.
NEGROS, P. I. März, April, 1896 (*J. Whitehead*, collector); LUZON, Province of Benguet, P. I. (*R. C. McGregor*, collector).
34. *A. nitidissima* Blanch., Cat. Coll. Ent. (1850) 194.
LUZON, Province of Albay, P. I. (*J. Whitehead*); NEGROS OCCIDENTAL, Bago, Louisiana, P. I. (*R. M. Araneta*).
35. *A. obesa* Cand., Col. Hefte, (1869) V, 41.
LUZON, Manila, P. I.
36. *A. præmatura* Ohs. sp. nov.
LUZON, P. I., 5–6000 feet; Albay, P. I., März, April, 1896. (*J. Whitehead*, collector); NEGROS OCCIDENTAL, Mailum, P. I. (*C. S. Banks*, collector).
37. *A. prasina* Burm., Hand. (1844) IV, 1, 277.
LUZON, Province of Albay, Albay, P. I.; MINDORO, P. I., November, 1895, Januar, 1896 (*J. Whitehead*).
38. *A. smaragdina* Eschsch., Entomogr., (1822) 18; Burm., Handb. (1844) IV, 1, 276.
LUZON, Manila, P. I.; CATANDUANES ISLANDS, P. I. (*J. Whitehead*).

MIMELA Kirby.

Trans. Linn. Soc. (1825) XIV, 101.—Burm., Handb. (1844) IV, 1, 285.

39. **M. blumei** Hope, Trans. Ent. Soc. London (1835) I, 116; Burm., Handb. (1844) IV, 1, 289.

PHILIPPINE ISLANDS.

40. **M. maculicollis** Ohs., Deutsche Ent. Zeitschr. (1908) 636.

LUZON, Province of Albay, Albay, P. I. (*J. Whitehead*); SIBAY, P. I. (*D. C. Worcester*).

41. **M. palawana** Ohs. sp. nov.

PALAWAN, Bacuit, Mt. Capoas, P. I. (*C. M. Weber*, collector).

MALAIA Heller.

Deutsche Ent. Zeitschr. (1891) 298.

42. **M. thoracica** Ohs. sp. nov.

N. LUZON, P. I. (*J. Whitehead*, collector).

PSEUDOMALAIJA Kraatz.

Deutsche Ent. Zeitschr. (1892) 296.

43. **P. flavopilosa** Ohs. Deutsche Ent. Zeitschr. (1905) 91.

NEGROS, P. I., März, April, 1896 (*J. Whitehead*).

44. **P. pilifera** Burm., Handb. (1844) IV, 1, 309.

LUZON, P. I., 5–6000 feet (*C. Semper*); Province of Cagayan, Cape Engaño, P. I.; Province of Albay, Albay, P. I. (*J. Whitehead*); Province of Benguet, Irian, P. I.; (*R. C. McGregor*); MINDANAO, P. I.

45. **P. semperi** Kraatz, Deutsche Ent. Zeitschr. (1892) 178.

LUZON, P. I. (*C. Semper*); NEGROS, P. I., März, April, 1896; LEYTE, P. I.; SAMAR, P. I., Juli, 1896 (*J. Whitehead*).

46. **P. tagala** Heller, Deutsche Ent. Zeitschr. (1891) 305.

LUZON, P. I. (*C. Semper*; *G. A. Baer*); N. LUZON, P. I., 5–6000 feet (*J. Whitehead*); Province of Benguet, Irian River, P. I. (*R. C. McGregor*); MINDANAO, Agusan River, P. I. (*A. Celestino*).

POPILLIA Serville.

Encycl. Method. (1825) X, 367.—Kraatz, Deutsche Ent. Zeitschr. (1892) 283.

47. **P. conopyga** Ohs., Deutsche Ent. Zeitschr. (1905) 92.

LUZON, Province of La Laguna, P. I.: Manila, P. I.

48. **P. cetrata** Newm., The Entom. (1841) I, 223.

N. LUZON, P. I. (*C. Semper*); Province of Benguet, Irian River, P. I. (*R. C. McGregor*); NEGROS OCCIDENTAL, Bago, Mailum, P. I. (*C. S. Banks*).

49. **P. depressa** Kraatz., Deutsche Ent. Zeitschr. (1892) 287.
 N. LUZON, P. I. (*C. Semper*); Province of Benguet, Irisan River, Baguio, P. I. (*R. C. McGregor*).
50. **P. depressiuscula** Kraatz., Deutsche Ent. Zeitschr. (1892) 286.
 LUZON, P. I. (*C. Semper*; *J. Whitehead*); Manila, P. I. (*Scha-
 denberg*).
51. **P. mcgregori** Ohs. sp. nov.
 LUZON, Province of Benguet, Pauai, P. I. (*R. C. McGregor*, collector).
52. **P. mutans** Newm., Trans. Ent. Soc. London (1841) III, 39.
 Var. *relucens* Blanch., Cat. Coll. Ent. (1850) 199.
 LUZON, Manila, P. I.
53. **P. oculata** Ohs. sp. nov.
 N. LUZON, P. I. (*C. Semper*; *J. Whitehead*, collectors).
54. **P. scalpta** Newm. The Entom. (1841) 222.—Arrow, Trans. Ent. Soc. London (1899) 274.
P. aemula Newm., l. c. 222.
P. pictalis Kraatz, Deutsche Ent. Zeitschr. (1892) 284.
 N. LUZON, P. I. (*C. Semper*; *J. Whitehead*).
55. **P. variabilis** Kraatz, Deutsche Ent. Zeitschr. (1892) 283.
 LUZON, P. I. (*C. Semper*); Province of Cagayan, Cape Engaño, P. I. (*J. Whitehead*); Province of Benguet, Irisan River, Cabayan, P. I. (*R. C. McGregor*).

II. RUTELINI GENUINI.

PARASTASIA Westwood.

- Ann. Nat. Hist. (1841) VIII, 204.—Ohaus, Monographie; Deutsche Ent. Zeitschr. (1900) 225–266.
56. **P. canaliculata** Westw., Ann. Nat. Hist. (1841) VIII, 204 u. 304 ♀.
 ♂ *bipunctata* Westw., l. c. p. 304.
 ♂ *rubrotessellata* Blanch., Cat. Coll. Ent. (1850) 217.
 LUZON, P. I. (*C. Semper*; *J. Whitehead*); Manila, P. I. (*T. Roeseler*); SAMAR, P. I., Juni, Juli, 1896 (*J. Whitehead*).
57. **P. confluens** Westw., Ann. Nat. Hist. (1841) VIII, 304 ♂.
 ♂ *rugosicollis* Blanch., Cat. Coll. Ent. (1850) 217.
 ♂ *degenerata* Snell. v. Vollenh., Tijdschr. v. Ent. Nederl. (1864) VII, 147.
 ♀ *pileus* Snell. v. Vollenh., l. c. p. 147 t. IX, f. 3.
 LUZON, P. I. (*C. Semper*); MINDANAO, Camp Keithley, P. I. (*Mrs. M. S. Clemens*); SIBUYAN ISLAND, P. I. (*R. C. McGregor*).
58. **P. discolor** Westw., Ann. Nat. Hist. (1841) VIII, 304.
 LUZON, P. I. (*C. Semper*).

59. *P. indica* Ohs., Stettin. Ent. Zeit. (1898) 9; Deutsche Ent. Zeitschr. (1900) 257.

PHILIPPINE ISLANDS.

60. *P. nigriceps* Westw., Ann. Nat. Hist. (1841) VIII, 304.

NEGROS, P. I., März, April, 1896 (*J. Whitehead*); PHILIPPINE ISLANDS (*C. Semper*).

61. *P. nigroscutellata* Ohs., Deutsche Ent. Zeitschr. (1901) 125.

LUZON, Province of Cagayan, Cape Engaño, P. I. (*J. Whitehead*).

62. *P. nonfriedi* Ohs., Stettin. Ent. Zeit. (1898) 10.

PALAWAN, P. I. (*W. Schultze*).

63. *P. westwoodi* Waterh. ex Westw., Ann. Nat. Hist. (1841) VIII, 304.

MINDORO, Balete, Baco River, P. I. (*R. C. McGregor*); MINDANAO, Zamboanga, Port Banga, P. I. (*W. I. Hutchinson*).

LUTERA Westwood.

Trans. Ent. Soc. London (1875) 236.

64. *L. nigromaculata* Ohs., Deutsche Ent. Zeitschr. (1900) 261; l. c. (1905) 97.

LUZON, Province of Camarines, P. I.

III. ADORETINI.

ADORETUS Castelnau.

Hist. Nat. (1840) II, 142.

65. *A. luridus* Blanch., Cat. Coll. Ent. (1850) 234.

LUZON, P. I. (*C. Semper*; *O. Warburg*); Manila, P. I. (*C. S. Banks*; *W. Schultze*).

66. *A. philippinicus* Pic, Le Naturaliste (1905) 131.

LUZON, P. I. (*C. Semper*; *J. Whitehead*); Manila, P. I.; ROMBLON, P. I. (*R. C. McGregor*).

67. *A. ranunculus* Burm., Handb. (1844) IV, 1, 474.

LUZON, P. I. (*C. Semper*; *J. Whitehead*); Manila, P. I. (*C. S. Banks*; *W. Schultze*).

68. *A. umbrosus* Fabr., Ent. Syst. (1892) I, 2, 169.—Burm., Handb., (1855) IV, 2, 532. Blanch., in Hombroen et Jacquinet, Voy. Pol. Sud. (1853) IV, 109.

A. mutabilis Blanch., l. c. Atlas pl. 8, fig. 7.

PHILIPPINE ISLANDS.

FISHES OF BORNEO, WITH DESCRIPTIONS OF FOUR NEW SPECIES.

By ALVIN SEALE.

(From the Section of Fisheries, Biological Laboratory, Bureau of Science,
Manila, P. I.)

The following collection of fishes was secured by me at Sandakan, British North Borneo, February 10 to 14, 1908. Of the one hundred and seventeen species, ninety-one were common to Borneo and the Philippines. Twenty-six only were recorded from Borneo and not from the Philippines. The method of measurement is the same as that used by Jordan and Evermann.¹ The color markings recorded are all from specimens which have been two years in alcohol.

Family CARCHARIIDÆ. Sharks.

Charcharias borneensis Seale, sp. nov. Plate I.

Head 4; depth 5.1; eye 6.50 in head; snout but slightly less than interorbital; middle of eye exactly midway between tip of snout and second gill arch; no spicules; nostrils considerably nearer mouth than to tip of snout; length of under jaw 1.60 in snout; width of mouth at angle 1.25 in snout; five gill arches, the posterior ones above base of pectorals. Teeth all oblique in two rows at least $\frac{3}{4}$ on each side; all with swollen bases; those of the upper jaw have one large, sharp point and three smaller points on the inner side, the longest about one-third the size of the large point; these graduate in size, both the large and small points are denticulate. Each tooth of the under jaw consists of a single, smooth, sharp point on a swollen base. I was unable to detect any denticulations on the lower teeth. (See Plate I, figs. 3 and 4).

The origin of the ventral is located posteriorly to the pectorals by a distance one-third greater than the eye, the fin being midway between the tip of snout and the middle of the base of the second dorsal; height of dorsal 1.50 in head, its base 1.75 in its height; origin of second dorsal midway between tip of caudal and fourth gill opening; height of second

¹ *Bull. U. S. Nat. Mus.* (1896), 47, pt. 1, ix.

dorsal about equal to its base; caudal with two notches, its length one-third greater than head; a distinct pit at base of caudal both above and below; origin of anal midway between origin of ventrals and origin of caudal, being directly below the second dorsal; origin of ventrals midway between under part of caudal and anterior gill opening; length of outer margin of pectorals 1.10 in head, the inner margin 2.60 in outer, the posterior margin concave.

Color in alcohol uniform pale drab above, yellow below; fins uniform with coloring of body, except the second dorsal which has its upper two-thirds black.

This species in appearance resembles *C. dussumieri* (Val.), but the location of the fins and the form of the teeth are different. This is also true of *C. acutus* (Rüppell) which it also resembles.

Type, No. 2720 in the collection of the Bureau of Science, from Sandakan, Borneo. Length, 372 millimeters.

Family DASYATIDÆ. Sting Rays.

Dasyatis kuhli (Müller and Henle).

Color brown above, with large round blue spots; belly yellowish-white. No. 2503; disk 140 millimeters in diameter.

A common sting ray of Borneo, used as food; also found in the Philippines.

Family CLUPEIDÆ. Herrings.

Ilisha xanthoptera Bleeker.

Head 4.25, measured to tip of upper jaw; eye 3.75; adipose eyelid well developed; snout 3.35; depth 3.85; scutes strong, 7 on gular region and 27 on belly, a total of 34; dorsal 17; anal 49; villiform teeth on palatines and minute teeth in each jaw; none on vomer. Origin of anal below posterior rays of dorsal.

Color silver bluish from above; a dusky blotch on upper anterior part of opercle, and another posterior to upper portion of opercle; tip of jaws dusky. No. 2713; length, 370 millimeters.

A food-fish of Borneo, not recorded from the Philippines.

Family SYNODONTIDÆ. Lizard-fishes.

Saurida tumbil (Bleeker).

This specimen agrees with Bleeker's² description and figure. It is common in Borneo and used as food. It has not been recorded from the Philippines. No. 2587; length, 195 millimeters.

² Atlas Ichthyologique (1866-1872), 6, 155, pl. 277, fig. 4.

Family MURÆNESOCIDÆ. Eels.

Murænesox cinereus (Forskål).

Color drab-brown above, paler below. The lateral line very distinct; fins yellowish, the tips of dorsal and anal black, these fins becoming entirely dusky near and at end of caudal. Snout long; teeth large, the vomerine teeth with cusps on each side. Nos. 2498, 2500; length 490 to 556 millimeters.

A fish of considerable food importance in Borneo; also recorded from the Philippines.

Family CYPRINIDÆ. Minnows.

Barbus elongatus Seale, sp. nov. Plate II, fig. 1.

Head 4; depth 3.1; dorsal 12; anal 8; scales 5-27 (to end of caudal vertebra)-4; the lateral line curves down to a little below the median line of sides, then up to middle of base of caudal; eye 3.75 in head; snout 4; interorbital 2.70; maxillary scarcely reaching to anterior margin of eye; two maxillary barbules on each side, the longest 2 in head; pectorals about equal to head; ventrals 1.15 in head. No teeth except pharyngeals which are 4-3-2, the larger ones slightly hooked and each with a small shoulder.

Body oblong, compressed, the outline between origin of dorsal and tip of snout somewhat gibbous and with a concave area above the eye; caudal peduncle rather long and slim, its depth being 1.75 in its length; origin of dorsal midway between tip of snout and end of caudal vertebra, the second large ray enlarged and serrated on its upper two-thirds; the enlarged hard portion equal to distance from middle of eye to end of opercles; origin of anal much nearer origin of ventrals than the end of caudal vertebra, longest anal ray 1.70 in head; origin of ventrals midway between origin of anal and posterior margin of opercles; caudal deeply emarginate, its length greater than head. Gill openings restricted, ending on a line with angle of preopercle. Gill rakers small, rather sharp pointed, about 9 on lower arch.

Body entirely covered with large smooth scales which have 4 to 8 striate lines; tubes of lateral line unbranched; ventral with axillary scale; scaly sheaths to dorsal and anal; head entirely naked.

Color silvery with a slight shade of yellowish; four round black spots on middle line of sides, one at base of caudal, one at origin of lateral line, two on the lateral line near the middle. A black spot at origin of anal. Upper rays of dorsal, anal, and caudal, dusky.

This species is nearly related to *Barbus ivis* Seale from Balabac Island, from which it is easily distinguished by its more elongated form, long caudal peduncle, the more anterior location of the anal, and the less distance between the anal and ventrals. This species also has a larger eye.

Type, No. 2566 in the collection of the Bureau of Science, from Sandakan, Borneo. Length 80 millimeters.

Family SILURIDÆ. Catfishes.

Arius sagor Hamilton.

Hexanematichthys sundaicus Bleeker, Atlas Ichth. (1862), 2, 26, pl. 62.

Bleeker³ gives an excellent figure of this species. It is easily recognized by the banded appearance of the upper half of the body. These bands extend down to, or slightly below, the single lateral line and are evident even in specimens which have been long in alcohol. The young do not show the banded markings.

There are four patches of teeth on the palatine, separated by inter-spaces. The bony shield at base of dorsal spine is separated from the head shield. No. 2497; length, 370 millimeters; Nos. 2437, 2462 and 2518; length, 115 to 135 millimeters, young.

The species is regarded as an excellent food-fish and is common in the market of Sandakan. It has not been reported from the Philippines.

Tachysurus venosus (Cuvier and Valenciennes).

Arius venosus Bleeker, Atlas Ichth. (1862), 2, 33, pl. 54, fig. 1.

Grayish with a silvery wash; the fins have a slightly darker shade; under parts white. Nos. 2514 and 2625; length, 135 to 170 millimeters.

Characterized by an almost smooth head. Two triangular shaped areas of villiform teeth on the palate. A common food fish of Borneo. This species is recorded by Cuvier and Valenciennes from Manila.

Arius argyropleuron (Kuhl and Van Hasselt).

Grayish with a yellowish wash; yellowish white below. No. 2682; length, 145 millimeters.

Characterized by the ovate maxillary patch of granular teeth, the elongate snout, and the dusky, adipose fin. A food fish of Borneo, not reported from the Philippines.

Family PLOTOSIDÆ. Sea Catfishes.

Plotus anguillaris (Bloch.).

Color drab-gray; three longitudinal white stripes on each side from tip of head to tip of tail; fins all washed with slate-gray, darker at extremities; chin, belly, and throat yellowish cream. Nos. 2683, 2446, 2677, 2655; length, 160 to 195 millimeters.

This species is regarded as a good fish, but owing to the stinging wounds inflicted by its spines and because of its small size, it is not often seen in the market. It is also common throughout the Philippines.

³ Atl. Ichth. (1862), 2, pl. XIV.

Family BELONIDÆ. Needlefishes.

Tylosurus strongylurus (Kuhl and Van Hasselt).

Head 2.60; eye 3 in postocular portion of head; origin of ventrals midway between origin of pectorals and middle of base of anal. Nos. 2538 and 2696; length, 250 millimeters.

This species is easily distinguished by the round black spot on the base of the rays of caudal.

A food-fish of Borneo; also recorded from the Philippines.

Tylosurus anulatus (Cuv. and Val.).

Head 3; eye 2 in postorbital portion of head; origin of ventrals midway between end of caudal vertebra and anterior margin of eye.

Color silvery, washed with brownish above; pectorals, dorsal, caudal, and anterior part of anal, dusky. Nos. 2667 and 2718; length, 290 to 300 millimeters.

A food-fish of Borneo; also recorded from the Philippines.

Family EXOCETIDÆ. Half-beaks and Flying-fishes.

Zenarchopterus buffonis Cuv. and Val.

Head 4; depth 6; eye 1.50 in postorbital portion of head; snout 2 in head; interorbital space considerably greater than eye; dorsal 11; anal 12; origin of ventrals midway between tip of caudal and the posterior margin of opercle. Prolonged portion of under jaw beyond the upper 3.75 in head. Length from posterior margin of opercle to tip of under jaw much less than from posterior margin of opercle to end of caudal vertebra. Nos. 2622, 2672, and 2699; length, 170 to 215 millimeters.

A small brackish-water fish, dried and sold for food in considerable numbers in Borneo; also recorded from the Philippines.

Hemirhamphus gaimardi (Cuv. and Val.).

Head 4.25; depth 1.75 in head; exposed under jaw, beyond the upper, 1.75 in head; ventrals located midway between end of caudal vertebra and anterior margin of eye; dorsal 15; anal 15; origin of dorsal very slightly in advance of origin of anal; caudal forked.

Color silvery, bluish above; a blue and a silver line along the side; tip of dorsal and posterior portion of caudal dusky. Nos. 2473, 2640, 2664 and 2666; length, 145 to 195 millimeters.

A food-fish of Bornéo; also recorded from the Philippines.

Zenarchopterus dux Seale, sp. nov. Plate II, fig. 2.

Head, from tip of upper jaw, 4 to end of caudal vertebra; lower jaw, beyond the upper, 3 to end of vertebra; posterior margin of opercle midway between tip of lower jaw and end of caudal vertebra; dorsal 12; anal 14, the 6th ray modified into an intromittent organ; scales in lateral series 41, about 45 in lateral line, 6 in vertical series; eye 3.75 in head;

snout 3.1; width of exposed upper jaw equal to its length; origin of anal midway between end of caudal vertebra and origin of ventrals, being below fifth dorsal ray; length of ventrals 2.50 in head; length of pectorals 2.50 in head; caudal truncate, its length equal to distance from posterior end of upper jaw to end of opercle; body covered with smooth deciduous scales.

Color yellowish with a silver stripe along side which is bordered above with dark green. A dusky wash on dorsal and caudal, the anal with a distinct dusky blotch anteriorly.

Type, No. 2679 in the collection of the Bureau of Science, from Sandakan, Borneo. Length, 150 millimeters.

Family ATHERINIDÆ. Silversides.

Atherina forskalii Rupp.

Head 3.50; depth 4; eye 2.30 in head; interorbital about equal to eye; dorsal V-10; anal I, 12; scales 39 in lateral series from enlarged scale above opercle.

Common in Borneo and the Philippines.

Family MUGILIDÆ. Mulletts.

Mugil belanak Bleeker.

One specimen collected agrees with Bleeker's⁴ description and figure.

Color yellowish with a slight brownish wash above; scales with slightly darker centers, giving an indistinctly striped appearance; adipose eyelid moderately developed; tip of maxillary exposed. Origin of spinous dorsal about midway between tip of snout and end of caudal vertebra; origin of ventrals midway between origin of anal and notch of preorbital; origin of anal very slightly in advance of origin of dorsal. No. 2481; length, 175 millimeters.

An important food-fish of Borneo; not reported from the Philippines.

Liza cæruleomaculatus (Lacépède).

Color silvery, slightly bluish above; a black spot at upper axil of pectorals; scales 38. Nos. 2559 and 2602; length, 120 millimeters.

A common and valuable food-fish of Borneo; also recorded from the Philippines.

Family SPHYRÆNIDÆ. Barracudas.

Sphyræna toxusa Forster.

Head 3.30; depth 6.50; eye 5.50; interorbital 4.75; scales 115.

Dusky above; white below; all the fins more or less stained with gray. No. 2736; length, 440 millimeters.

A valuable food-fish of Borneo; not yet recorded from the Philippines.

⁴Java, 4, 337.

Family POLINEMIDÆ. Threadfins.

Polydactylus zophomus Jordan and McGregor.

Five pectoral appendages, the longest not extending beyond middle of pectoral; posterior half of dorsal black; a black spot at origin of lateral line; pectorals shaded with dusky punctulations; tip of ventrals with a slight dusky wash; general color uniform silvery. Nos. 2448, 2624, 2638, and 2687; length, 90 to 100 millimeters.

It is possible that *P. zophomus* Jordan & McGregor is another synonym for *P. plebeius* (Broussonet).

Polynemus tetradactylus Shaw.

Four pectoral appendages, the longest of which extends to middle length of ventrals; tips of fins, except ventrals, shaded with dusky. Head 3.50; depth 3.75. General color silvery with slight brownish wash above. No. 2489; length, 265 millimeters.

A common food-fish of Borneo; also recorded from the Philippines.

Family SYNGNATHIDÆ. Sea-horses.

Hippocampus kuda Bleeker.

A series of four specimens illustrates a considerable degree of variation in this species due to age; the older specimens are much less spinate than the young; a very decided change is seen in the coronet which in the younger form is decidedly five-spined, but with advancing age the front spines gradually atrophy, leaving a three-spined coronet.

The color varies from yellowish-white in young to almost black in adult; usually some five black specks are discernible; all show a more or less banded appearance of the snout. Nos. 2727, 2728, 2729, and 2730; length, 100 to 140 millimeters.

This species is common in Borneo, and also has been taken at numerous points in the Philippines.

Hippocampus barbouri described by Jordan and Richardson⁵ from Cuyo Island is doubtless this species.

Gasterotokeus biaculeatus Bloch.

Nos. 2731, 2732, 2733, 2734 and 2735; length, 205 millimeters.

This species is used to a considerable extent in China as medicine; it is common in Borneo and all over the Philippines.

Family STROMATEIDÆ. Butterfishes or Pomfrets.⁶**Stromateus cinereus** (Bloch.).

Head 3.50; depth 1.50; eye 3.50 in head; snout 1.25 in eye; inter-orbital 2 in head. No ventrals. Anterior rays of dorsal and anal elongate.

⁵ *Bull. U. S. Bu. of Fisheries* (1908), 27, 247.

⁶ In Hongkong fishes of the family *Stromateidæ* are called pomfrets.

Color dull yellowish, some small dusky dots on sides of head and chin. Nos. 2439 and 2894; length 100 to 116 millimeters.

Used for food in Borneo; not yet recorded from the Philippines.

Family SCOMBRIDÆ. Mackerels.

Rastrelliger brachysomus (Bleeker).

Color dull bluish-gray above, silvery with a yellowish wash below; posterior margin of dorsal dusky, fins otherwise uniform; round dusky spots at base of dorsal. Nos. 2648, 2649 and 2695; length 190 to 200 millimeters.

This species is easily distinguished by its great depth (3 in length), its long gill rakers which project into the mouth making it look "as if full of feathers." Scales below base of pectorals slightly the largest. This species is well described by Jordan and Dickerson.⁷

A common food-fish of Borneo; also found in the Philippines.

Lactarius lactarius (Bloch and Schneider).

Head 2.85; depth equal to head; eye 3.30 in head; dorsal VIII-I, 24; anal III, 26; scales about 60; a row of small teeth in jaws with two or three enlarged canines. Teeth on vomer and palatine.

Color silvery, a very distinct opercular spot. Dorsals grayish at tips. No. 2610; length, 100 millimeters.

Family CARANGIDÆ. Pampanos.

Caranx speciosus (Forskål).

This species is easily recognized by its yellow color, with the alternating wide and narrow black bands over the body, the anterior one being through the eye; the distinctness of these stripes seems to vary a great deal, but they are never entirely absent. I have seen very old specimens of 400 millimeters in length with the markings very distinct. Nos. 2458, 2465, and 2630; length, 85 to 250 millimeters.

Caranx sexfasciatus (Quoy and Gaimard).

Carangus rhabdotus Jenkins, Bull. U. S. Bu. Fisheries (1903), 23, pl. 1, 193.

Caranx semisomnus Fowler, Journ. Acad. Nat. Sci. Philad. (1904), 12, 2d. ser. 510, pl. 16.

Head 3.10; depth at origin of anal 2.55; eye 3.75 in head; snout 3.50; interorbital space 3.40; dorsal VIII-I, 21; anal II-I, 17; scales about 52 in curved portions of lateral line, and 30 scutes in the straight portion; the line becomes straight under the second soft ray of dorsal, the curved por-

⁷ Proc. U. S. Nat. Mus. (1908), 34, 603.

tion is 1.45 in the straight, the depth of the curve is equal to the length of snout; breast fully scaled. Adipose eyelid covering the iris posteriorly, very slightly developed anteriorly, cheeks scaled; opercles naked except on upper portion. Maxillar ending on a line with posterior margin of pupil, its length 2.10 in head. A single row of small sharp teeth in each jaw with some slightly enlarged canines anteriorly; the upper jaw in addition has bands of setiform teeth interiorly; teeth on vomer, palatine, and tongue.

Color silvery, with golden reflections. The young have five dusky vertical bands; tips of dorsals and caudal grayish, fins otherwise yellow. A small opercular spot. Inner axil of pectorals dusky. Nos. 2469, 2483, 2567, and 2653; length, 66 to 260 millimeters.

An abundant food-fish of Borneo; also common in the Philippines.

***Caranx brevis* Bleeker.**

Head 4 to end of scutes; depth 3; eye 3.50 in head; snout 3.50; interorbital 3.50; maxillary 2.80, ending on a line with anterior margin of pupil, dorsal VIII-I, 21; anal II-I, 17; 44 scutes in straight portion of lateral line, the line strongly curved, becoming straight under origin of soft dorsal; the curved portion 2.3 in the straight; depth of curve equal to eye; depth of largest scute one-third less than width of eye. Breast scaled; teeth small, in single series in each jaw; villiform teeth on vomer, palatine, and tongue.

Color grayish-blue above, silvery with a yellowish wash below; a very large and distinct opercular spot. Fins yellow, margin of soft dorsal with a wash of grayish; spinous dorsal grayish. Nos. 2460, 2464, and 2646; length, 175 to 260 millimeters.

A common food-fish of Borneo; also recorded from the Philippines. Resembles *C. megalaspis* Bleeker, but the scutes are of much less depth.

***Caranx ira* (Cuv. and Val.).**

Head 3.50; depth 2.55; eye 3.30 in head; snout 3.10; interorbital equals eye; maxillary 2.50, ending on a line with anterior margin of pupil. Breast scaled; lateral line with low curve, becoming straight under 9th dorsal ray; scutes 28, straight portion of line 1.25 in curved; depth of curve less than eye; dorsal VIII-I, 23; anal II-I, 19. Teeth of upper jaw in two series, those of lower jaw in single series, villiform teeth on vomer, palatines, and tongue.

Color silvery with a bluish tint above. Fins all yellowish-white, except soft dorsal, which has the lobe very black, with a white tip, a very characteristic marking for the species. Nos. 2613 and 2738; length, 137 millimeters.

A common food-fish of Borneo; also recorded from Negros, Iloilo, and Manila, Philippine Islands.

Citula armatus (Forskål).

Characterized by the peculiar shape, and the elongate ventral, dorsal, and anal; the ventrals extend beyond caudal; the spinous dorsal is represented by six minute spines; scutes very small.

Color silver, with indistinct dusky bands; a more distinct band extends through the eye. No. 2545; length, 86 millimeters.

A common food-fish of Borneo; also found in the Philippines.

Scomberoides lysan (Forskål).

These specimens are silvery with a bluish wash above; the fins yellowish, the soft dorsal slightly grayish without distinct dusky blotch. The species may be distinguished by the deep body, the short snout, which is less than eye, and the long premaxillary, which is 1.50 in head, ending posteriorly to eye.

Large specimens have the grayish blotches, like finger prints, 6-7 in number, all above the lateral line, except the two anterior ones. Nos. 2459, 2484, and 2506; length, 178 to 300 millimeters.

A food-fish of some importance in Borneo; also recorded from the Philippines. This species affords excellent sport with rod and reel.

Family TRICHIURIDÆ. Cutlass-fishes.

Trichiurus haumela (Forskål).

Head, from tip of upper jaw 6.85; eye 5.35 in head; snout 2.90; interorbital 2.50 in snout.

Color silvery, tip of dorsal dusky. Anterior anal spines not enlarged. No. 2657; length, 334 millimeters.

A common food-fish at Sandakan; also found throughout the Philippines.

Family EQUULIDÆ. Slip-mouths.

Gazza minuta (Bloch).

Head 3; depth 2; eye 2.50, lateral line complete; breast naked; rather strong canine teeth in jaws.

Color silvery, with more or less bronzy reflections; some very indistinct mottling showing on the back in some specimens; axil of pectorals dusky; tip of dorsal with very slight trace of dusky color; fins yellowish-white. Nos. 2569, 2605, 2650, 2658, and 2757; length, 87 to 110 millimeters.

Important as a food-fish because of its abundance. Found also in the Philippines.

Equula ruconia (Hamilton).

Head 3.75; depth 1.50; eye 2.50 in head; lateral line incomplete.

Color yellowish-brown above, with brownish bands and markings; silvery below. Axil of pectoral dusky; some dusky dots on sides of

thorax; a dark line from orbit to chin; tip of dorsal with a slight trace of dusky color. Nos. 2468, 2708, and 2781; length, 45 to 50 millimeters.

Common food-fish of Borneo; also found in the Philippines.

Leiognathus blochii Cuv. and Val.

Head 3; depth 2.1; eye 3 in head; snout 3; interorbital about 3; dorsal VIII, 16; anal III, 14; scales 55 to end of caudal vertebra. A small spine in front of orbit, lower margin of preopercle serrated, mandible moderately curved; length of median crest 2.60 in head, second dorsal spine 2.50 in depth.

Color yellowish-brown above, silvery below; a black band around tip of snout; a dusky blotch on shoulder at end of nuchal spine; numerous vertical or undulating lines over back. Inner axil of pectoral black; some dusky coloring on inside of gill openings. Day⁸ gives a good figure of this species, although in our specimens the dusky saddle on shoulder is not so distinct. Nos. 2556, 2644, 2662, 2711, 2748, and 2756; length, 66 to 100 millimeters.

A common food-fish of Borneo; also recorded from the Philippines.

Leiognathus caballa (Cuv. and Val.).

Head 3; depth 1.55; eye 2.70 in head; dorsal VIII, 16; anal III, 14; second dorsal spine 2.80; breast naked; lateral line complete; superorbital edge serrated; nuchal spine 1.75 in head.

Color grayish-silvery above, with numerous fine vertical lines over back down to near median line of sides; no black on the fins, which are yellowish-white. Nos. 2463, 2515, 2520, and 2551; length, 70 to 110 millimeters.

Leiognathus edentulus Bloch and *L. dussumieri* Cuv. and Val. both have the breast fully scaled and are probably synonymous; they certainly are not the above species which has the breast naked.

Leiognathus splendens (Cuvier).

Head 3.10; depth 1.75; eye 2.50 in head; snout 3 in head; interorbital 2.60; first dorsal spine 2.50 in depth of fish; nuchal crest 1.85 in head; orbital serrated; two distinct spines in front of eye on each side; breast fully and distinctly scaled.

Color silvery, darker above, with some irregular vertical markings scarcely showing, and entirely obsolete in some specimens. A distinct dusky blotch on upper portion of spinous dorsal. Axil of pectoral dusky; end of snout dusky; some dusky markings at tip of anal. Nos. 2543, 2690, 2737; length, 65 to 89 millimeters.

A food-fish of importance because very abundant. Also found throughout the Philippines.

⁸ Fishes of India (1878). 241, pl. 52, fig. 5.

Family APOGONICHTHYIDÆ. Cardinal Fishes.

Amia hyalosoma Bleeker.

Color yellowish, a large black spot on base of anal; black between anterior dorsal spines. Nos. 2608 and 2629; length, 115 millimeters.

Too small to be of much importance as food. Common also in the Philippines.

Amia quadrifasciata (Cuv. and Val.).

Color yellowish, two or three brown stripes on upper half of body, the lower stripe extending to tip of caudal fin; the arrangement of scales on sides gives the appearance of vertical bands. Nos. 2440, 2577, 2594, 2596, 2636, 2676, 2745, 2768, and 2780; length, 57 to 88 millimeters.

Common in Borneo and the Philippines.

Pseudoamia polystigma Bleeker.

Color brownish, specked; a black spot on opercle with a short brown line above it; two brown lines passing downward and backward from the eye. Nos. 2580, 2595, 2663, and 2743; length 65 millimeters.

Common in Borneo; also in the Philippines.

Amia ceramensis Bleeker.

Color yellowish, a black dot on base of caudal; a narrow dusky line along middle of side. Nos. 2456 and 2571; length, 67 to 69 millimeters.

Common in Borneo and the Philippines, but too small to be of importance as a food-fish.

Family AMBASSIDÆ. Climbing Perches.

Ambassis kopsi (Bleeker).

Color in alcohol yellowish-white with an indistinct silvery line down the middle of side. Nos. 2476, 2540, 2544, 2592, 2568, 2753, and 2783; length, 62 to 95 millimeters.

Common in Borneo and in the Philippines; of no importance as food.

Priopis gymnocephalus Lacépède.

Nos. 2707 and 2724; length, 50 to 63 millimeters.

Common in Borneo and also in the Philippines. Too small to be of importance as food.

Family SERRANIDÆ. Sea-basses.

Psammoperca waigiensis (Cuv. and Val.).

Similar to *Lates calcarifer* (Bloch), but without spines on lower border of preopercle.

Color uniform dull brown, centers of scales slightly darker; fins like body, except pectorals and ventrals which are yellowish-white. The

ventrals are slightly stained with gray. No. 2647; length, 166 millimeters.

A valuable food-fish of Borneo; also common in the Philippines.

Lates calcarifer (Bloch).

Silvery-gray; fins gray; pectorals yellow. Strong spines on lower margin of preopercle. No. 2490; length, 290 millimeters.

A valuable food-fish of Borneo; recorded also from the Philippines.

Epinephelus sexfasciatus (Cuv. and Val.).

Color brownish, with dull yellowish and brownish spots; six darker vertical bands down sides; fins grayish without distinct markings. Ventrals darker at tips. No. 2098; length, 121 millimeters.

A valued food-fish of Borneo; also recorded from the Philippines.

Family LUTIANIDÆ. Snappers.

Lutianus erythropterus Bloch.

This species is easily distinguished by the white mark in the posterior axil of the soft dorsal which is followed by a deep black area covering the remainder of the top of caudal peduncle. No. 2900; length, 210 millimeters.

A common food-fish of Borneo; also recorded from the Philippines.

Nemipterus upeneoides (Bleeker).

Head 3.45; depth 3.50.

Color yellowish-white with silvery reflection; darker above; a round dusky spot on the lateral line above middle of pectorals. No. 2516; length, 130 millimeters.

A common food-fish of Borneo; not known from the Philippines.

Lutianus fulviflamma (Forskål).

Color white, with longitudinal yellow stripes; a distinct black blotch on each side. Young specimens have a dusky stripe from eye to tip of snout and on upper portion of preopercles. Fins yellowish. Nos. 2519, 2548, 2486, and 2739; length, 100 to 230 millimeters.

A common and valued food-fish of Borneo; also recorded from the Philippines.

Lutianus vitta (Quoy and Gaimard).

Yellowish-white, with a distinct black line along the side from head to caudal. No dusky shadings on dorsal. No. 2493; length, 210 millimeters.

A food-fish of value in Borneo; also common in the Philippines.

Family HÆMULIDÆ. Grunts.

Spilotichthys pictus (Thunberg).

Our specimens show the complete transformation from the older specimens on which round brownish spots cover the body and extend on the dorsal and caudal, to the young specimens with dark longitudinal bands which are just beginning to break up into rows of round spots. Nos. 2491, 2467, 2604, 2643, and 2740; length, 120 to 210 millimeters.

This species during its various color changes may be distinguished by the presence of only 10 dorsal spines.

A food-fish of importance in Borneo; also recorded from the Philippines.

Euelaticthys crassispinus (Rüppell).

Head 3; depth 2.1; dorsal spines 14.

Color dusky; the fins black without white margins or spots; pectorals grayish-white. The center of each scale is lighter in color giving the appearance of narrow light lines on sides. No. 2489; length, 175 millimeters.

A food-fish of value; also recorded from the Philippines.

Pristipoma hasta Bloch.

Color yellowish with a silvery wash; back and dorsal fins with black spots. No. 2442 represents the form called *P. negeb* Rüppell, probably a color variation. Nos. 2479, 2635, 2442, and 2758; length, 81 to 210 millimeters.

Common in Borneo; also recorded from the Philippines.

Pristopoma therapon Bleeker.

Color silvery; a large oval black spot occupying a large portion of the spinous dorsal, otherwise uniform in color. No. 2589; length, 80 millimeters.

A food-fish of value in Borneo; also recorded from the Philippines.

Family THERAPONIDÆ. Therapons.

Scolopsis vosmaeri Bleeker.

Similar in every respect to the figure given by Bleeker.⁹ Color yellowish white; a white longitudinal stripe backward from origin of lateral line; another white band over nuchal region. No. 2717; length, 156 millimeters.

An important food-fish of Borneo; also found in the Philippines.

⁹ Atlas Ichthy. (1876-1877), 8, 8, pl. 61, fig. 5.

***Therapon quadrilineatus* (Bloch).**

Color silvery, with five longitudinal brown lines on sides; caudal unmarked; a black blotch on spinous dorsal; grayish on anal; tip of soft dorsal dusky. Nos. 2612, 2671, 2725, 2715, 2782, and 2792; length, 77 to 100 millimeters.

A common inshore food-fish of Borneo and the Philippines.

***Therapon jarbua* (Forskål).**

This common species is identical in every respect with the Philippine form. It is characterized by the concave brown lines on sides, the oblique bands on the caudal, and the dusky markings on the dorsal. No. 2615; length, 130 millimeters.

***Therapon puta* (Cuv. and Val.).**

Characterized by the elongate teeth of the preopercle; four straight brown lines on body; oblique brown lines on caudal, the central line of which is straight, being a prolongation of the median brown line of the body; dorsals with dusky markings. Nos. 2524, 2528, 2529, 2530, 2531, and 2749; length, 78 to 100 millimeters.

A common inshore food-fish of Borneo and the Philippines.

Family SPARIDÆ. Porgies.

***Sparus calamara* Russell.**

Color yellowish; centers of scales darker; dorsals, caudal, anal, and ventrals, with dusky tips. No. 2499; length, 200 millimeters.

A food-fish of importance in Borneo; also recorded from the Philippines.

***Lethrinus amboinensis* Bleeker.**

Similar to specimens from the Philippines. Color dull brownish, indistinctly mottled with greenish; a dusky spot between pectoral fin and lateral line. Nos. 2438, 2558, 2582, 2679, and 2742; length, 80 to 120 millimeters.

An excellent food-fish; also found in the Philippines.

Family GERRIDÆ. Mogarras.

***Zyæma punctatum* (Cuv. and Val.).**

Head 3; depth 2.40; eye 2.50 in head.

Color silvery below, with a wash of yellowish; brown above. Some very indistinct darker bands or spots over back. This species is characterized by the elongate second dorsal spine, which in our specimens equals the head. Nos. 2451, 2564, and 2588; length, 75 to 92 millimeters.

A common food-fish of Borneo, also recorded from the Philippines.

Xystæma kapas (Bleeker).

This species has the third anal spine considerably longer than the second; however, the latter is the strongest. Head 3.1; depth 2.35; eye 2.75 in head; snout 4.

Color dull light brown above, silvery below; fins yellowish. No. 2537; length, 87 millimeters.

A common food-fish of Borneo; also found in the Philippines.

Xystæma oyena (Forskål).

Head 3.1; depth 2.1; eye 2.55 in head; snout 3.50; interorbital 2.75; second dorsal spine 2.50 in depth; the third anal spine is the longest, but the second is the strongest.

Color yellowish-white, margin of spinous dorsal dusky, tip of caudal with an indistinct dusky shade. No. 2609; length, 105 millimeters.

A common food-fish of Borneo; also recorded from the Philippines.

Xystæma lucidus (Cuv. and Val.).

Head 3.1; depth 2.30; eye 2.50; snout 4; interorbital 3; second dorsal spine 2.20 in depth; second anal spine longer and stronger than the third.

Color yellowish, slightly darker above with 4 or 5 wide distinct darker bands over back, tip of dorsal black. No. 2583; length, 92 millimeters.

A food-fish of but little importance in Borneo; not recorded from the Philippines.

Xystæma abbreviatus (Bleeker).

Depth about 2 in length; eye 2.50 in head (measured with jaws not projected), pectorals extending well along the base of anal.

Color silvery; centers of scales slightly darker; tip of dorsal dusky. Nos. 2478 and 2542; length, 114 to 185 millimeters.

A food-fish of importance in Borneo; also found in the Philippines.

Family MULLIDÆ. Goat-fishes.

Upeneoides tragula (Richardson).

I have examined several hundred specimens of this species, and they are without exception distinctly speckled with black, with a distinct black line along each side, the anterior dorsal is very largely dusky, the caudal is always distinctly marked with oblique lines; the ventrals and anal are marked with two or three dusky lines. These, aside from structural differences, make the species very easily recognized. Nos. 2435, 2545, 2553, and 2616; length, 110 to 155 millimeters.

A food-fish of Borneo; also recorded from the Philippines.

Upeneoides vittatus (Forskål).

Color dull silvery-brownish; a yellow line on sides; tip of dorsal black, a black line through the middle of fin, another through base of fin; soft

dorsal with three dusky bands; caudal with oblique dusky bands. Belly yellow; anal, ventrals, and pectorals unmarked. Nos. 2554 and 2645; length, 105 to 140 millimeters.

This is a shorter, deeper fish than *U. tragula* (Richardson) and is without black dots.

A food-fish of some importance; also recorded from the Philippines.

Upeneoides sulphureus (Cuv. and Val.).

This species in form and markings somewhat resembles *U. vittatus* (Forskål). However, it has the caudal uniform or with a single dusky line at the margin of the lower lobe; the actual tip of the lower caudal lobe is white; dorsals barred with dusky; ventrals, pectorals and anal yellow, without markings. No. 2633; length, 120 millimeters.

A food-fish of Borneo; also common in the Philippines.

Upeneoides luzonius (Jordan and Seale).

An indistinct dusky saddle over back, just behind soft dorsal; a dusky longitudinal line from eye to caudal; dorsals scarcely marked; caudal with rather fine oblique dusky bars, 7 on lower lobe. Nos. 2447, 2517, 2555, 2572, 2579, 2618, and 2632; length, 90 to 136 millimeters.

This species was originally described from the Philippines.

Family SCLÆNIDÆ. Croakers.

Umbrina russelli Cuv. and Val.

Silvery, a dusky band over shoulders; a dusky blotch on opercles; anterior dorsal dusky; a short barbule; no enlarged canines. No. 2552; length, 103 millimeters.

Common food-fish of Borneo; also recorded from the Philippines.

Otolithus maculatus (Kuhl and Van Hasselt).

Color silvery, the upper portion of body with some scattered spots; our specimens show some indistinct markings on soft dorsal fin. No. 2495; length, 260 millimeters.

A food-fish of Borneo; not recorded from the Philippines.

Pseudosciaena diacanthus (Lacépède).

Color grayish-silvery with numerous brown spots over body and fins; pectorals, ventrals, and anal of a uniform dusky color. No. 2654; length, 165 millimeters.

An important food-fish of Borneo; not recorded from the Philippines.

Johnius borneensis (Bleeker).

Color silvery; tips of dorsals grayish; caudal grayish; an indistinct dusky spot on opercles. No. 2509; length, 205 millimeters.

A food-fish of Borneo; not recorded from the Philippines.

Johnius vogleri Bleeker.

Color dull yellowish with slight silvery reflections; centers of rows of scales darker; a slight wash of grayish on spinous dorsal. No. 2445; length, 190 millimeters.

A food-fish of considerable importance in Borneo; not recorded from the Philippines.

Pseudosciaena anea (Bloch).

Color silvery; fins yellowish-white; jaws almost equal, teeth strong.

Head 2.85; depth 3; eye 4.25 in head; dorsal X-I, 24; anal II, 7; scales about 43; rather strong, curved teeth in each jaw; upper jaw with an inner row of small teeth, none on vomer, palatine, or tongue. No. 2452; length, 105 millimeters; No. 2512; length, 135 millimeters.

A common food-fish of Borneo; also recorded from the Philippines.

Otolithus dolorosus Seale, sp. nov. Plate III.

Head 3.75; depth 5; scales 54 in lateral line, 11 between lateral line and base of anal, 11 between origin of dorsal and lateral line; dorsal XI, 25; anal II, 7; eye 6.20; snout 4.15; interorbital 5; maxillary 2.50; its posterior margin ending under anterior margin of pupil; cheeks and opercles scaled, the opercle with a single flat spine; jaws with small sharp teeth in two or more rows, the outer row slightly enlarged with about 4 enlarged curved canines anteriorly on each jaw; no teeth on vomer, palatine, or tongue; gill rakers rather strong, not very sharp, the longest about equal to diameter of pupil, about 14 on lower arch.

Body oblong, slightly compressed; lower jaw projecting; length of caudal peduncle (measured to a line with posterior axil of anal) greater than depth of body, and almost equal to head; depth of caudal peduncle 3 in its length; longest dorsal ray 1.75 in head; the two dorsals not separated; origin of anal midway between base of caudal and axil of ventrals, under the seventh dorsal ray. First anal spine minute, the second about two-thirds the length of second anal ray; the origin of the ventral considerably nearer the tip of lower jaw than to origin of anal; length of ventrals about 1.40 in head; pectorals 1.30 in head; caudal 1.15 in head; scales of body in oblique rows, those of lateral line enlarged, arborescent.

Color uniform silvery, with more or less distinct narrow black lines following the rows of scales above the lateral line, tip of dorsal and caudal dusky; axil of pectorals dusky.

This species somewhat resembles *O. argenteus* (Kuhl and Van Hasselt), but has much smaller teeth and the location of the fins is decidedly different, the origin of anal being much nearer the base of caudal in *O. argenteus*.

Type, No. 2485 in the collection of the Bureau of Science, from Sandakan, Borneo. Length, 300 millimeters.

Otolithus orientalis Seale, sp. nov. Plate IV.

Head 3.20; depth 4.1; dorsal XI, 28; anal 2.7; scales 51 in lateral line, 7 between origin of anal and lateral line, 6 between origin of dorsal and lateral line; eye 5.45 in head; snout 4.15; maxillary 2.45 ending on a line with posterior margin of pupil; interorbital equal to snout; lower jaw slightly projecting, teeth of upper jaw small, sharp, in two or more rows, those of lower jaw similar but in a single row on each side, two very large curved canines in each jaw anteriorly. No teeth on vomer, palatine, or tongue. Gill rakers short, not very sharp, about 12 on lower arch, the longest scarcely equal to pupil.

Body oblong, slightly compressed, the dorsals not completely divided; longest dorsal spine 2 in head; length of caudal peduncle (measured to angle of anal) about 1.35 in head, being slightly less than depth of fish; its depth 3 in its length. Origin of anal very much nearer to end of caudal vertebra than to axil of pectoral, being under the middle of soft dorsal; second anal spine very short, less than one-third of first ray. Origin of ventrals nearer tip of snout than to anal pore; length of ventrals 1.75 in head; pectorals 1.50 in head; caudal 1.75.

Color uniform silvery with a slight yellowish wash above and with indistinct dusky lines following the rows of scales which run obliquely, the lines extending to below the lateral line; dorsals and caudal tipped with grayish, a grayish spot in axil of pectoral.

Characterized by the posterior position of anal and ventral, the number of scales, and the teeth.

Type, No. 2744 in the collection of the Bureau of Science, from Sandakan, Borneo. Length, 235 millimeters.

Family SILLAGINIDÆ. Kisugos.

Sillago sihama (Forskål).

Head 3.45; depth 5; eye 4 in head.

Color dull yellowish; a silvery stripe along side, which scarcely shows. Tip of dorsal dusky. Nos. 2492, 2755, and 2769; length, 120 to 220 millimeters.

A common food-fish of Borneo; also found in the Philippines.

Family LABRIDÆ. Urasse-fishes.

Chærodon oligacanthus (Bleeker).

Color greenish, a black spot under sixth dorsal spine; just behind and above this is a large whitish area, scarcely showing in some specimens; some indistinct bluish longitudinal streaks on sides, most distinct anteriorly; the young specimens show, in addition, a black spot below and slightly posterior to axil of soft dorsal; the young also may have an additional blackish blotch midway between these black spots (see No. 2455). The ventrals are quite long, reaching to the soft rays of anal.

Nos. 2455, 2480, 2482, 2505, 2525, and 2621; length, 110 to 270 millimeters.

A valued food-fish of Borneo; also recorded from the Philippines.

Family TOXOTIDÆ. Ring-fishes.

Toxotes jaculatrix (Pallas).

Nos. 2475 and 2611; length, 89 to 125 millimeters.

Common in the streams of Borneo; also in the Philippines. Not highly esteemed as food.

Family SCATOPHAGIDÆ. Kitings.

Scatophagus argus (Gmelin).

Color yellowish-white with a bluish wash. The entire fish, except under parts, covered with numerous round bluish spots. The young are similar but have larger spots. Nos. 2549 and 2722; length, 75 to 120 millimeters.

An important and excellent food-fish in Borneo; also recorded in the Philippines.

Family DREPANIDÆ. Eastern Spade-fishes.

Drepane punctata (Gmelin).

Color silvery, with about ten vertical rows of dots over the back and downward to median line or a little below on sides; a black spot in axil of pectoral; ventral dusky at tip. Nos. 2507 and 2581; length, 100 to 165 millimeters.

A food-fish of value; also recorded from numerous places in the Philippines.

Family EPHIPPIDÆ. Ehippids.

Ehippus orbis (Bloch).

Head 3.15; depth 1.20; three anterior dorsal spines elongate.

Color silvery; very indistinct indications of about four wide dusky bands on back and sides, more distinct in young specimens; pectoral and caudal yellowish; other fins with a grayish tinge. Nos. 2474 and 2626; length, 104 millimeters.

A rare fish in Borneo; not yet recorded from the Philippines, but reported from Formosa.

Family SCORPIDIDÆ. Scorpids.

Monodactylus argenteus (Linnaeus).

Color silvery; a black orbital band; an additional band at posterior margin of opercles; caudal and pectorals yellow, dorsal and anal grayish, ventrals represented by small spines. No. 2750; length, 60 millimeters.

A valuable food-fish of Borneo; also recorded from numerous places in the Philippines.

Family PLATACIDÆ. Leaf-fishes.

Platax orbicularis (Forskål).

Dusky, with black ocular band, another band across posterior portion of opercles; two short bands across caudal peduncle; caudal and pectorals yellowish; other fins grayish, becoming black at tips. Nos. 2477 and 2689; length, 95 to 100 millimeters.

Not of much importance as a food in Borneo; common in the Philippines.

Family CHÆTODONTIDÆ. Butterfly-fishes.

Chætodon ocellatus Bleeker.

Color yellowish with five brown bands; the anterior one darkest and forming the ocular band. The upper portion of the third band has a round black spot at the base of soft dorsal. The fourth is on the margin of dorsal and anal fins. This band has white margins on the caudal peduncle. No. 2575; length, 65 millimeters.

Of no importance as a food-fish; recorded also from one locality in the Philippines.

Family HEPATIDÆ. Tangs.

Hepatus matoides (Cuv. and Val.).

Color dull brownish; a gray ring around base of caudal; dorsal and anal black; ventrals black at tips; pectorals yellowish; caudal grayish at base and on upper and lower margins, darker in center. No. 2721; length, 130 millimeters.

A food-fish of considerable value; also recorded from the Philippines.

Family SIGANIDÆ. Siganids.

Siganus vermiculatus Kuhl and Van Hasselt.

Head 4; depth 2; eye 3.50.

Color dull brown, with numerous vermiculating blue lines. No. 2684; length, 226 millimeters.

A common food-fish of Borneo, not greatly prized; also found in the Philippines, where it is extensively used in the manufacture of *bagoñg*, a native sauce.

Siganus javus (Linnæus).

Head 3.90; depth 2.10; eye 3.10 in head.

Color dull brown above, with blue dots which become larger and form longitudinal lines on the lower half of body. The blue color really predominates below and gives the appearance of brownish longitudinal lines on a bluish background. Nos. 2454 and 2513; length, 118 to 190 millimeters.

A common food-fish of Borneo; also common in the Philippines.

Siganus albopunctatus (Temminck and Schlegel).

Head 3.1; depth 2.50; eye 3.35 in head.

Color pale brownish above, bluish below; body covered with small blue dots, considerably less than interspaces; yellowish-brown spots on the shoulders. No. 2470; length, 222 millimeters.

A common food-fish of Borneo; also recorded from the Philippines.

Siganus hexagonata Bleeker.

Head 3.75; depth 2; eye 3 in head.

Color bluish, with brownish hexagonal spots larger than the interspaces. The young show scarcely any marking after being in alcohol a short time. No. 2488; length, 235 millimeters; Nos. 2436 and 2685; length, 100 millimeters.

A common food-fish of Borneo; also recorded from the Philippines.

Siganus fuscens (Houttuyn).

Head 3.65; depth 2.45; eye 3.1.

Color dull bluish with some indistinct darker spots. Nos. 2561 and 2754; length, 50 to 90 millimeters.

Common in Borneo; also in the Philippines.

Family TRIACANTHIDÆ. Three-spines.

Triacanthus blochi Bleeker.

Head 3.10; depth 2.80; eye slightly greater than interorbital, 3.10 in head; snout 1.3 in head.

Color silvery, with yellowish blotches on sides. Nos. 2598, 2599, 2619, 2688, and 2793; length, 65 to 110 millimeters.

Common in Borneo; also recorded from the Philippines. Not used as food unless skinned immediately after death.

Family MONOCANTHIDÆ. One-spines.

Monacanthus chinensis (Bloch).

Color dull yellowish-brown, covered with numerous small black spots; caudal barred with dusky. Easily distinguished by the very elongate ventral fin. Nos. 2532, 2661, 2677, 2723, and 2743; length, 70 to 150 millimeters.

Common in Borneo, also in the Philippines, but not used as food as it is reputed poisonous.

Family TETRAODONTIDÆ. Puffers, Poison-fishes.

Tetraodon immaculatus (Bloch and Schneider).

In the series before me the young are colored and marked the same as the adult, all being dull brown above and yellowish-white below; with four or five longitudinal lines down the back. Only one specimen, No.

2784, shows many lines on the belly. Nos. 2502, 2710, 2774, 2777, and 2784; length, 44 to 184 millimeters.

Common in Borneo; also in the Philippines. Regarded everywhere as poisonous.

Tetraodon fluviatilis (Hamilton).

Characterized by the large round black spots which cover the body; belly yellowish-white; caudal distinctly barred with black. Nos. 2527, 2600, 2601, 2628, 2680, 2681, and 2771; length, 45 to 110 millimeters.

Common in Borneo; also recorded from the Philippines. Regarded as poisonous.

Spheroides lunaris (Bloch).

Depth about 3; eye 3.10. Color silvery; a slight dusky wash on back. Nos. 2560, 2656, 2677, and 2691; length, 90 to 150 millimeters.

Common in Borneo; also in the Philippines. Poisonous.

Family GOBIIDÆ. Gobies.

Rhinogobius caninus (Cuv. and Val.).

The most distinctive color marking of this fish is the blue-black spot just above, and on a line with, the posterior margin of opercles. There are also about five dusky blotches along sides, alternating with the dusky bands over back; fins more or less grayish; ventrals darker. The males usually have the anterior dorsal spines elongate. Nos. 2443, 2457, 2522, 2550, 2591, 2620, 2623, 2631, 2642, 2674, 2718, 2746, and 2778; length, 75 to 120 millimeters.

Common in Borneo, also in the Philippines. It is of no importance commercially.

Oxyurichthus cristatus (Day).

Our specimen corresponds perfectly with the description and figure given by Day.¹⁰ No. 2765; length, 95 millimeters.

Common in Borneo and the Philippines.

Rhinogobius nebulosus (Forskål).

The mottlings on this specimen are not so distinct as on our Philippine specimens, but this is probably due to methods of preservation. No. 2767; length, 75 millimeters.

Gnatholipis callurus Jordan and Seale.

Our specimens from Borneo are identical with the cotype of this species from the Philippines, except number 2593, which seems to have a slightly sharper profile and may be a different species. Nos. 2453, 2586, 2593, 2694, and 2787; length, 50 millimeters.

¹⁰ Fishes of India (1878), 291, pl. 62, fig. 8.

Glossogobius aglestes Jordan and Seale.

These specimens have the large mouth and the color markings of the Philippine cotypes of this species, although an examination of a good series may show specific differences. Our specimens are in poor condition. Nos. 2701, 2707, and 2712; length, 85 millimeters.

Family SCORPÆNIDÆ. Scorpion-fishes.

Gennadius stoliczæ (Day).

Color pale yellowish, mottled with brownish; fins barred with brown; no cranial spines. No. 2606; length, 110 millimeters.

Not common; recorded from the Philippines.

Prosopodasys trachinordes (Cuv. and Val.).

Dorsal III, 12, 4, anal III, 3.

Color yellowish, mottled with brownish specks; fins barred with dark brown. Nos. 2472, 2533, 2693, 2702, 2709, 2762, 2763, 2775, and 2791; length, 48 to 62 millimeters.

Not recorded from the Philippines, and differing chiefly from Philippine species of this genus in the number of spines.

Polycaulus elongatus (Cav. and Val.).

These specimens agree with Day's description and figure,¹¹ which he states are identical with Bloch and Schneiders type examined by him. Nos. 2534, 2741, and 2779; length, 60 to 85 millimeters.

Not reported from the Philippines.

Family PLATYCEPHALIDÆ. Flatheads.

Thysanophrys tentaculatus (Rüppell).

Color clove-brown, without distinct bands over back, all the fins more or less mottled with brownish; anal and ventrals tipped with brownish; however, the ventrals are fully colored above. Tentacles of eye very distinct, the spines at angle of opercles very short, about equal to width of nostril. Head with few low spines. No. 2496; length, 315 millimeters.

This species is common at Sandakan; it has also been recorded from Cuyo, Philippine Islands. It is esteemed as a food-fish.

Platycephalus indicus (Linnæus).

Pale sepia above, yellowish-white below; rays of the dorsals barred with brown; a dark median line on middle of caudal fin with converging dark lines from the upper and lower portions of the fin, meeting the median line at its extremity; four or five brown dots on the upper ray of caudal.

¹¹ Fishes of India (1878), 164, pl. 39, fig. 6.

The entire body has a more or less finely reticulated appearance. No. 2501; length, 160 millimeters.

A food-fish of small value. This species has been reported from numerous places in the Philippines.

Thysanophrys bobosok (Bleeker).

Brownish, with darker bands over back; sides of head with four dark vertical stripes about as wide as interspaces; caudal banded with brownish and white; spinous dorsal with a large dusky blotch; second dorsal rays banded with brown; anal yellowish-white, some dusky spots on margin; pectorals and ventrals with brownish markings. Lateral line with small spines anteriorly; preopercular spine 7 in head. Nos. 2504, 2573, 2652, 2678, 2704, 2714, and 2772; length, 77 to 155 millimeters.

A very common species but not large enough to be of importance for food. It has not yet been recorded from the Philippines.

Thysanophrys scaber (Linnæus).

Grayish-brown, with some very indistinct dusky bands over back; ventrals and anals with dusky tips; spinous dorsal and caudal each with a dusky blotch; soft dorsal and pectorals barred with brown. Characterized by the lateral line having spines extending its entire length. Nos. 2449, 2641, and 2665; length, 150 to 180 millimeters.

A common species in Borneo, but not yet reported from the Philippines.

Our specimens differed from the figure given by Bleeker¹² in having the lower and posterior half of caudal taken up by a large dull dusky blotch, the brown bars showing only on the upper portion of the fin. It may be different.

Family PLEURONECTIDÆ. Flounders.

Microbuglossus humilis (Cantor).

Color dull brown, with numerous fine dusky spots; a row of larger round black spots near bases of fins. Nos. 2563, 2570, 2576, 2697, 2764, and 2766; length, 60 to 70 millimeters.

Not recorded from the Philippines.

Pseudorhombus javanicus Hamilton.

Color dull brown, with slightly darker blotches and spots; two dark spots on lateral line, one of which has scarcely a trace of an angle above the nostrils, the other has it quite distinct. Nos. 2466 and 2471; length, 155 to 175 millimeters.

It is probable that Jordan and Richardson¹³ were wrong in regarding *P. polyspilus* collected by Doctor Lung in Cavite as belonging to this species.

¹² Atlas Ichthy. (?) 9, pl. 419, fig. 5.

¹³ Bull. U. S. Bur. Fisheries (1907), 37, 281.

Cynoglossus borneensis (Bleeker).

Head 4; depth 4.

General color dull yellowish-white; the fins darker posteriorly. No. 2659; length, 130 millimeters.

Common in Borneo; not recorded from the Philippines.

Cynoglossus kapwasensis Fowler.

Nos. 2461 and 2670; length, 95 millimeters. These specimens seem to correspond with the description and figure given by Fowler.¹⁴ His specimens came from Western Borneo.

Cynoglossus macrolepidotus Bleeker.

I refer this to the above species with considerable doubt, as our specimens seem to be of less depth, 5.50 in total length to tip of caudal. The head is 5.1, two lateral lines on left side, scales large. No. 2510; length, 210 millimeters.

A food-fish of Borneo of considerable importance; also recorded from the Philippines.

¹⁴ *Proc. Phil. Acad. Sci.* (1905), July, 519.

LIST OF ILLUSTRATIONS.

PLATE I.

- FIG. 1. *Charcharias borneensis* Seale, sp. nov.
2. Ventral surface of head.
3. Upper tooth.
4. Lower tooth.

PLATE II.

- FIG. 1. *Barbus elongatus* Seale, sp. nov.
2. *Zenarchopterus dux* Seale, sp. nov.

PLATE III.

Otolithus dolorosus Seale, sp. nov.

PLATE IV.

Otolithus orientalis Seale, sp. nov.

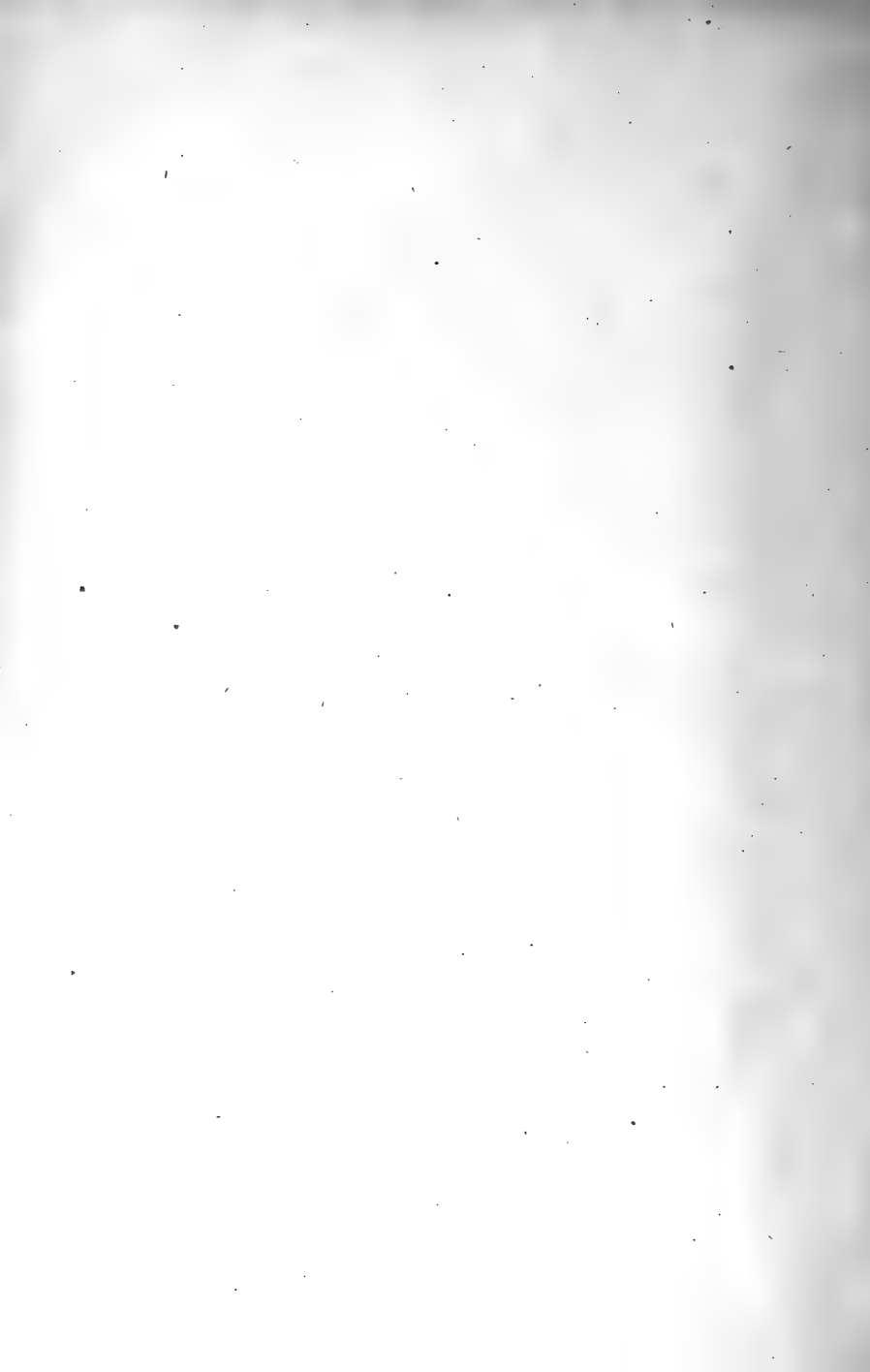



FIG. 2.



FIG. 1.



FIG. 3.



FIG. 4.

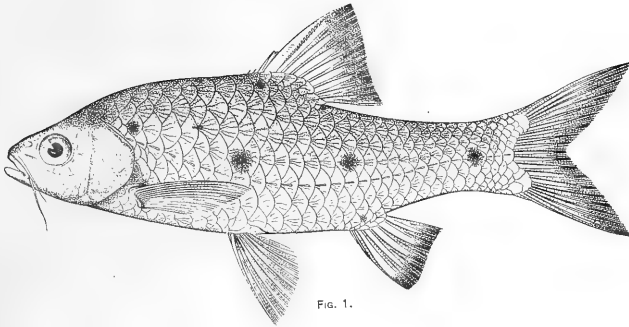

FIG. 1.



FIG. 2.

PLATE II.

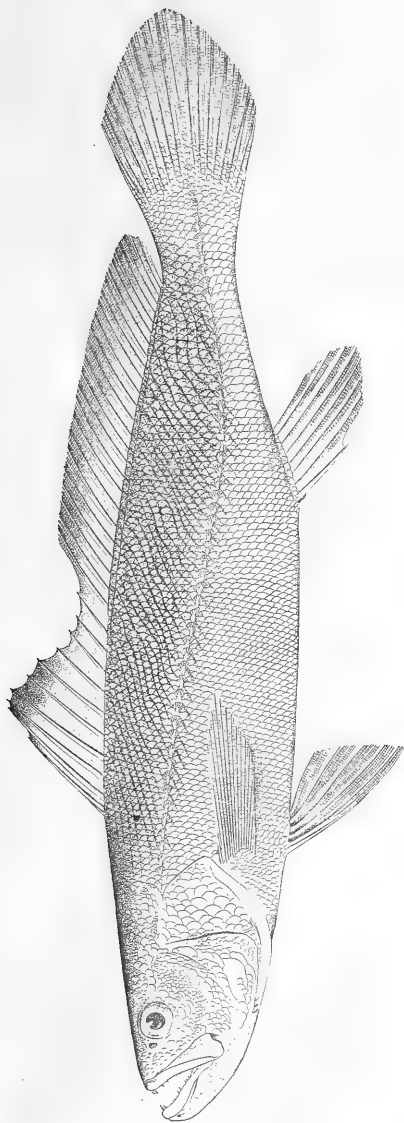
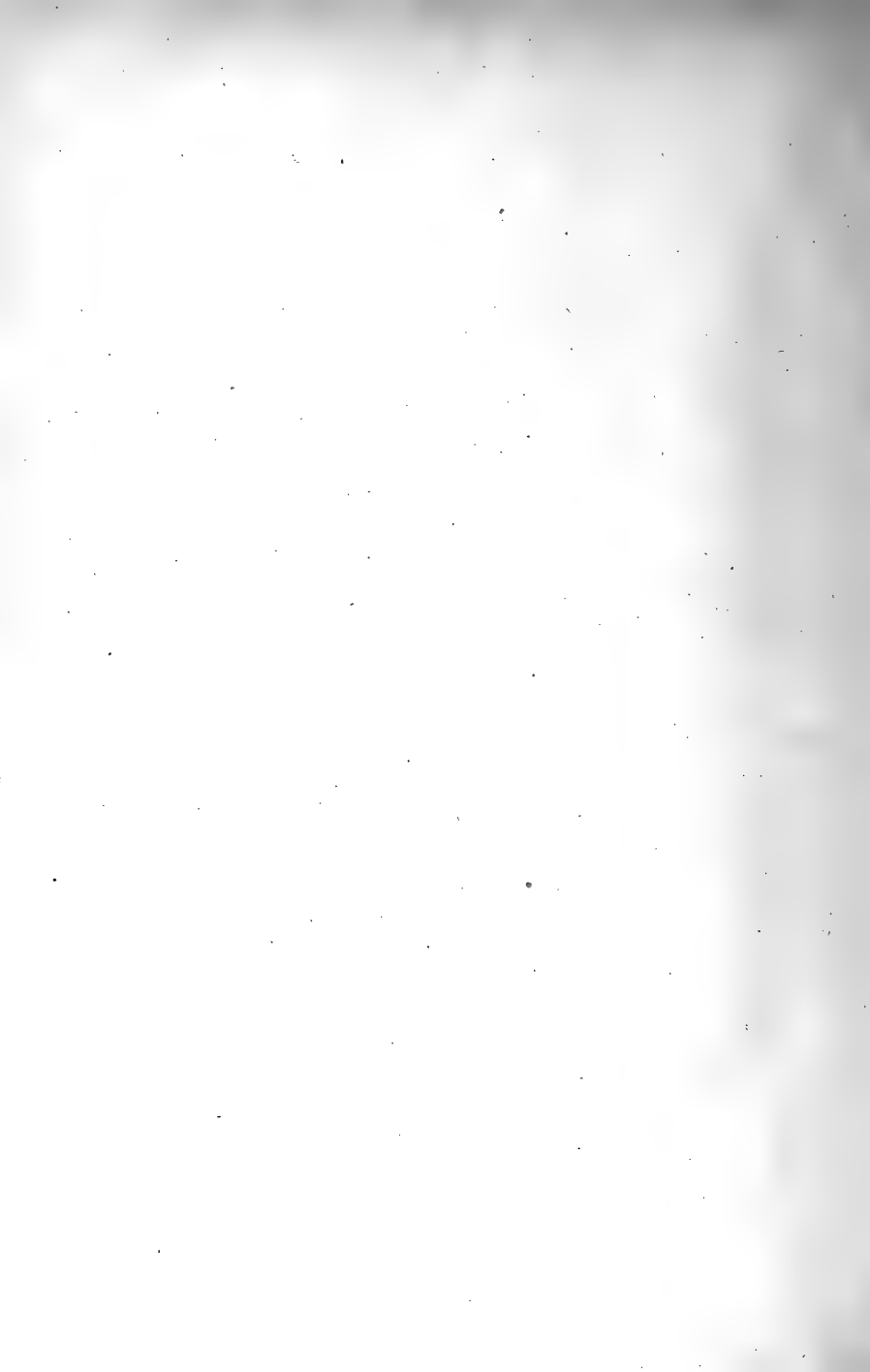
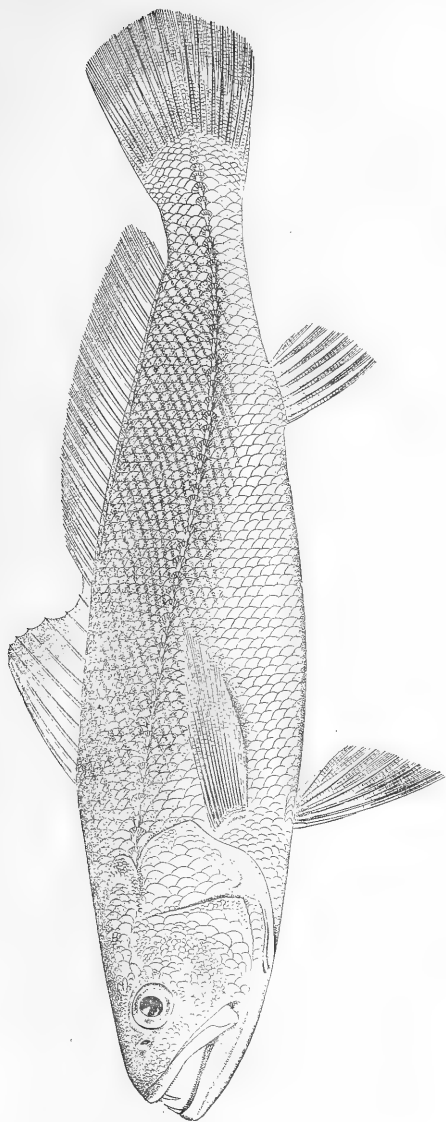

PLATE III.







Order No. 401.

THE BONTOC IGOROT.

By A. E. JENKS.

110 pages. 3 maps. 154 photographic plates. 9 figures.

An interesting study; the result of almost a year's residence among the Bontoc Igorots.

Price \$1 United States currency, postpaid.

Order No. 402.

NEGRITOS OF ZAMBALES.

By WILLIAM ALLAN REED.

62 photographic illustrations. 91 pages.

An interesting ethnological study of the pygmy blacks of Zambales.

Price \$0.25, United States currency, postpaid.

Order No. 403.

THE NABALOI DIALECT.

By OTTO SCHEERER.

TOGETHER WITH

THE BATAKS OF PALAWAN.

By EDWARD Y. MILLER.

199 pages. 1 map. 23 full-page photographic plates. 6 figures.

The result of research work among this interesting tribe of primitive people.

Price \$0.25, United States currency, paper, postpaid.

NOTE.

Orders should be sent to the Business Manager, Philippine Journal of Science, Manila, or to any of the below-listed agents. *Please give Order Number.*

FOREIGN AGENTS.

The Macmillan Company, 64-66 Fifth Avenue, New York City, U. S. A.
Messrs. Wm. Wesley & Son, 28 Essex Street, Strand, London, W. C., England.
Mr. Martinus Nijhoff, Nobelstraat 18, The Hague, Holland.
Messrs. Mayer & Muller, Prinz Louis Ferdinandstrasse 2, Berlin, N. W., Germany.
Messrs. Kelley & Walsh, Limited, 32 Raffles Place, Singapore, Straits Settlements.
Messrs. A. M. & J. Ferguson, 19 Baillie Street, Colombo, Ceylon.

CIRCULARS AND DESCRIPTIVE MATTER SENT ON APPLICATION.

Beginning with Volume V, a new section, "Section D, Ethnology, Anthropology, and General Biology," will be added to the Journal. The price for the whole series to subscribers for 1910 will be as heretofore, \$5 United States currency. Single subscriptions to Section D will be \$2 United States currency.

Beginning with 1911, the price of the entire Journal will be increased to \$7 United States currency. Section D will appear as often as material is available.

CONTENTS.

	Page.
GRIFFIN, LAWRENCE E. A List of Snakes from the Island of Polillo, P. I., with Descriptions of a New Genus and Two New Species -----	211
MCGREGOR, RICHARD C. Birds from the Coast of Northern Luzon and from the Islands of Sabtan and Dalupiri -----	219
WEISE, J. Ueber Chrysomeliden und Coccinelliden der Philippinen	223
OHAUS, FR. Die Ruteliden der Philippinischen Inseln -----	233
SEALE, ALVIN. Fishes of Borneo, with Descriptions of Four New Species -----	263

The "Philippine Journal of Science" is issued as follows:

Section A, Chemical and Geological Sciences and the Industries, \$2 United States currency per year.

Section B, Medical Sciences, \$3 United States currency per year.

Section C, Botany, \$2 United States currency per year.

Section D, Ethnology, Anthropology, and General Biology, \$2 United States currency per year.

The entire "Journal," \$5 United States currency for Volumes II, III, IV, and V. Thereafter, \$7 United States currency per year.

Authors receive 100 copies of their papers free.

Subscriptions should be sent to the Business Manager, Philippine Journal of Science, Bureau of Science, Manila, P. I., or to any of the agents listed below. Please give order number.

FOREIGN AGENTS.

The Macmillan Company, 64-66 Fifth Avenue, New York City, U. S. A.

Messrs. Wm. Wesley & Son, 28 Essex Street, Strand, London, W. C., England.

Mr. Martinus Nijhoff, Nobelstraat 18, The Hague, Holland.

Messrs. Mayer & Muller, Prinz Louis Ferdinandstrasse 2, Berlin, N. W., Germany.

Messrs. Kelley & Walsh, Limited, 32 Raffles Place, Singapore, Straits Settlements.

Messrs. A. M. & J. Ferguson, 19 Baillie Street, Colombo, Ceylon.

A limited number of unbound copies of previous volumes are available, which may be secured from the Business Manager, Philippine Journal of Science, Manila, P. I., at the following rates: Volume I, 1906 (not divided into sections), \$10 United States currency; Supplement to Volume I, \$3.50 United States currency; Volume I (without supplement), \$6.50 United States currency; all later volumes at current subscription prices.

ENTERED AT THE POST-
OFFICE AT MANILA P. I.
AS SECOND-CLASS MATTER.

Vol. V

NOVEMBER, 1910

No. 5.

THE PHILIPPINE
JOURNAL OF SCIENCE

EDITED BY

PAUL C. FREER, M. D., PH. D.

WITH THE COÖPERATION OF

DEAN C. WORCESTER, A. B.; ROBERT BENNETT BEAN, M. D.
MERTON L. MILLER, PH. D.; CHARLES S. BANKS, M. S.
ALVIN SEALE, A. B.; LAWRENCE E. GRIFFIN, PH. D.
RICHARD C. MCGREGOR, A. B.; NELLIE LOUISE COOK, B. L., M. A.

PUBLISHED BY

THE BUREAU OF SCIENCE

OF THE

GOVERNMENT OF THE PHILIPPINE ISLANDS

D. ETHNOLOGY, ANTHROPOLOGY, AND GENERAL
BIOLOGY

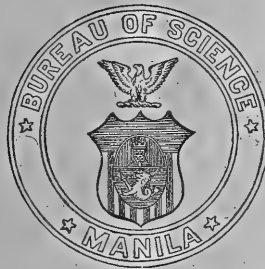

MANILA
BUREAU OF PRINTING
1910

Order No. 405.

STUDIES IN MORO HISTORY, LAW, AND RELIGION.

By NAJEEB M. SALEEBY.

107 pages. 16 illustrations. 5 diagrams.

A treatise on the history and customs of the Moro People.

Price \$0.25, United States currency, postpaid.

Order No. 406.

THE HISTORY OF SULU.

By NAJEEB M. SALEEBY.

275 pages.

A complete History of the Moro People in Sulu, with maps and many translations from the original documents.

Price \$0.75, United States currency, postpaid.

Order No. 410.

MINDANAO.

THE SUBANUNS OF SINDANGAN BAY.

By EMERSON B. CHRISTIE.

122 pages.

Profusely illustrated.

This, together with the History of Sulu and the Studies in Moro History, Law and Religion, is one of an authentic and valuable set of works on the origin, history and customs of these tribes, who are among the most interesting peoples of the world:

Price \$1.25, United States currency, postpaid.

NOTE

Orders should be sent to the Business Manager, Philippine Journal of Science, Manila, or to any of the below-listed agents. *Please give Order Number.*

FOREIGN AGENTS.

The Macmillan Company, 64-66 Fifth Avenue, New York City, U. S. A.
Messrs. Wm. Wesley & Son, 25 Essex Street, Strand, London, W. C., England.
Mr. Martinus Nijhoff, Nobelstraat 13, The Hague, Holland.
Messrs. Mayer & Muller, Prinz Louis Ferdinandstrasse 2, Berlin, N. W., Germany.
Messrs. Kelley & Walsh, Limited, 32 Raffles Place, Singapore, Straits Settlements.
Messrs. A. M. & J. Ferguson, 19 Baillie Street, Colombo, Ceylon.

CIRCULARS AND DESCRIPTIVE MATTER SENT ON APPLICATION.

THE PHILIPPINE
JOURNAL OF SCIENCE

D. ETHNOLOGY, ANTHROPOLOGY, AND
GENERAL BIOLOGY

Vol. V

NOVEMBER, 1910

No. 5

EUPLOTES WORCESTERI SP. NOV.: I. STRUCTURE.¹

By LAWRENCE EDMONDS GRIFFIN.²

This *Euplotes* was discovered in February, 1909, in some water from Manila Bay which was brought to the laboratory with the eggs of an *Aplysiid*. As the eggs decayed an infusion was produced in which the *Euplotes* multiplied freely. My attention was directed to this form by observing the process of division in a living individual and noting that the new peristome appeared to lie, not on the outer surface lateral or posterior to the old one, but inside the body, dorsal to the old peristome, remaining thus until the two halves of the body drew apart. This observation was so at variance with the processes of division occurring in the Protozoa with which I was then acquainted, that I made considerable effort to verify it. Further study disclosed numerous other features so interesting that it seemed desirable to make a complete study of the structure, division, and conjugation of the species. When this *Euplotes* was discovered there were at least three other species of hypotrichous infusoria in the culture, several species of other ciliates, together with flagellates and amœbæ. The *Euplotes* multiplied with far greater freedom than any of the other protozoa. From time to time since then, the growth of the *Euplotes* has been stimulated by dropping into the jar small pieces of thoroughly cooked fish or *Arcas*. The cooking was simply to avoid the possibility of adding fresh protozoa and bacteria to

¹ Contribution from the Biological Laboratory, Bureau of Science, Manila, P. I.

² Associate Professor of Zoology in the University of the Philippines.

the culture. Whenever a proper interval had passed since the previous infusion, a rapid increase of the Euplotes always took place, so that by the third day after starting a fresh infusion the animals could be found by hundreds in any drop taken from the under surface of the bacterial scum covering the water. The cultures usually reached their maximum development two or three days later; a few hours after this stage almost all the animals died. It was then impossible to bring about a multiplication of the animals in this jar by starting a fresh infusion until after the processes of decomposition of the preceding one had been completed, and the water cleared. Nevertheless, a few Euplotes could be found near the surface of the water at any time during this period.

A blue-green alga (an *Oscillatoria*) grew well on the sides of the jar from the beginning, and probably helped to preserve conditions favorable to the Euplotes. The other protozoa died out gradually until at the end of a year only one other form, a species of *Lembus*, remained with the Euplotes.

This Euplotes appears to be an undescribed species, very closely related to *E. vannus*; comparisons therefore are closely limited to the two forms. The new species is named in honor of the Hon. Dean C. Worcester, who has been interested in the study of protozoa for many years, and who has vigorously assisted the rapid development of scientific work and education in the Philippines.

The form of the animal is shown in Plate I, figure 1, and Plate II, figures 2, 3, and 4. The ventral surface is always flat, the dorsal surface

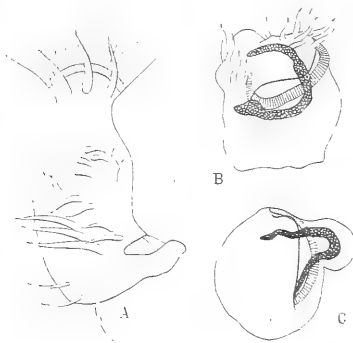

FIG. 1.—Outline sketches of three of the deformed individuals which appear when cultures have passed their prime. Specimen A seems to be the result of an aborted division.

considerably elevated in normal individuals. The curvature of the dorsal surface varies to a considerable degree in accordance with the amount of food eaten, so that in a fresh, rich infusion the animals are thicker bodied than in an old or poor infusion. In every culture some Euplotes can always be found which are much broader than the normal, oval in outline, and greatly flattened.

After cultures have passed their prime, greatly malformed individuals are sometimes common. These are always much flattened, the dorsal and ventral surfaces are parallel, and the thickness is sometimes only one-tenth of the width. A great distortion

of the form of the body accompanied by changes in the shape and position of the peristome frequently occurs. These abnormal forms probably are the result of the same conditions which presently cause the death of the greater part of the animals in the culture, that is, the accumulation of waste products and toxins of the Euplotes themselves and of the bacteria present.

From Plate I, figure 1, and Plate II, figures 2 and 4, it will be seen that the greater part of the peristome lies upon the ventral surface, in the shape of a shallow depression the median wall of which is vertical, while the lateral wall curves from the bottom of the peristome to the level of the ventral surface. The anterior portion of the peristome passes as a shallow vertical depression across the anterior end of the body to the right side. The inner wall of the peristome turns abruptly to form the ventral edge of this groove, while the lateral edge of the peristome passes over the left edge and then across the anterior end of the body. The anterior portion of the peristome is slightly overhung by the projecting dorsal surface.

A thin lamella projects from the margin of the inner wall, commencing at the right end of the peristome and continuing around the angle of the median wall. The vertical anterior portion of the peristome thus lies between the projecting ledge of the dorsal surface and the marginal lamella. (Plate I, figure 1; Plate II, figure 2.) I have never found this marginal lamella extending far back of the angle of the peristome. Minkiewicz publishes several sketches showing it to extend as far as the mouth in *E. vannus*. In other species of Euplotes, for example *E. harpa*, the marginal lamella is developed to a much greater extent. It is not vibratile, its function being purely passive.

Posteriorly, the lateral edge of the peristome turns toward the mid-line in a graceful curve, which is continued into the posterior wall of the pharynx. The posterior margin of the peristome is deepest next to the mouth, and the lateral wall becomes more and more nearly vertical as it approaches the mouth. The inner margin of the peristome sometimes stops where it joins the outer margin back of the mouth, but usually continues as a low ridge for a little distance past that point. A slight curvature of the inner wall of the peristome occurs below the mouth. (Plate I, figure 1, Plate II, figure 4.) The adoral zone of membranelle lies close against the outer margin of the peristome, leaving the median portion of the groove free from cilia or other vibratile organs.

The ventral surface curves dorsad rather abruptly back of the five large anal cirri, then again becomes horizontal; the caudal end of the body is thus much thinner than other parts. A low ridge extends along the right margin of the ventral surface. Each of the anal cirri stands in the posterior end of an elongated depression of the surface, separated by ridges which attain a far greater development in other species of the genus.

Mouth and pharynx.—The mouth is situated upon the vertical median

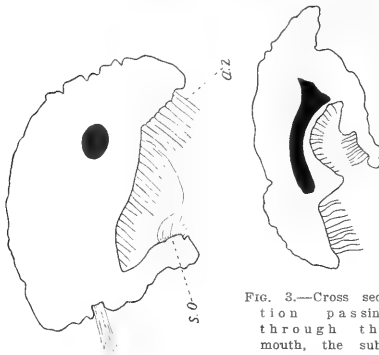

FIG. 2.—A cross section passing through the mouth, the adoral membranellæ, a. z., and the suboral membranellæ, s. o.



FIG. 3.—Cross section passing through the mouth, the suboral membranellæ, the pharynx and pharyngeal membranellæ, and the adoral zone.

wall of the peristome. The curving posterior side of the peristome forms its posterior and part of its dorsal margin.

The outline of the mouth, instead of being regularly round or oval, is quite irregular, being about twice as wide along the ventral edge as along the dorsal. The ventral extension of the mouth and pharynx accommodates a group of membranellæ to which I have applied the name *suboral*. (Plate I, figure 1; Plate III, figure 5; text figures 2 and 3.)

The bases of the suboral membranellæ lie in a definite oval area, possibly a region where the pellicle is thinned. By examining living specimens it was impossible to determine whether the suboral membranellæ were upon the ventral lip of the mouth, or upon the projection of the anterodorsal wall. The latter seemed to be the case. It was only when sections had been made that the exact position of the suboral membranellæ was demonstrated. Just posterior to the suboral membranellæ is a small elevation of the floor of the pharynx. (Text figures 3 and 6.)

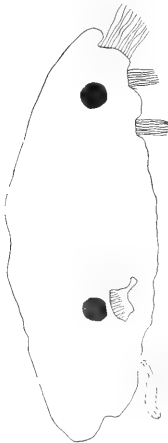

FIG. 4.—A longitudinal section, showing the anterodorsal groove of the pharynx.

The pharynx passes to the right and forward, its posterior outline being a continuation of the regular curve of the outer wall of the peristome. The pharynx narrows considerably just inside the mouth, after which the anterior wall approaches the posterior very gradually. The inner end of the pharynx is blunt and comparatively wide. The anterodorsal angle of the pharynx forms a deep groove which extends from the corresponding angle of the mouth to past the middle of the pharynx. (Plate III, figure 5; text figure 4.)

The zone of adoral membranellæ continues into the pharynx without a break, although with a gradual reduction in the length and breadth of

the individual membranellæ. The membranellæ of this series which lie inside the pharynx may, for convenience, be termed the *pharyngeal* membranellæ. They vary in number; usually there are from twenty to twenty-four, though a few more or less may be found. It will be observed that twenty-four membranellæ are shown in text figure 5, and that this section does not include quite the full length of the pharynx. Although the number of the membranellæ inside of the pharynx is subject to considerable variation, I have never noticed so small a number as 8, which is the number Minkiewicz found in his Black Sea specimens of *E. vannus*. I also find the pharynx to extend considerably farther into the body than is represented by the figures of Minkiewicz. It is often only by very careful examination, even with an immersion lens, that the inner end of the pharynx can accurately be outlined, partly because of the thickness of overlying granular protoplasm, and partly because of the increased delicacy of the vibratile organs in the inner part of the pharynx and of the walls of the pharynx itself.

The pharyngeal membranellæ lie on the rounded posterodorsal surface of the pharynx, leaving part of the dorsal surface which is not occupied

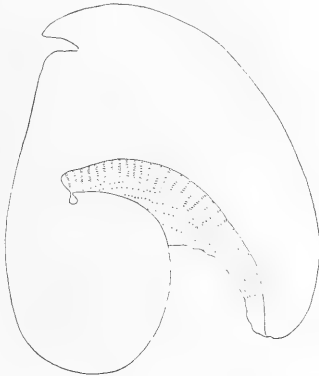

FIG. 5.—A tangential section passing through the dorsal wall of the pharynx. The rows of basal granules of the pharyngeal membranellæ and of the endoral cilia show the arrangement of these organs.

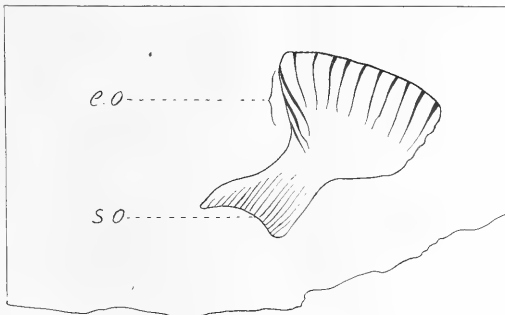

FIG. 6.—Part of a longitudinal section passing just inside the mouth. s. o., suboral membranellæ; e. o., endoral cilia, which in this section are well down on the anterior wall.

by them. In this space lie several oblique rows of fine cilia which probably are homologous with the endoral cilia of other Hypotricha. (See text figures 5 and 6; Plate I, figure 1.) At the oral aperture three or four of these rows (occasionally more) lie side by side, forming a ciliated band which extends from the mouth to the inner end of the pharynx, narrowing slightly as it passes inward. These cilia are the most difficult feature of the ciliation to observe in the living animal, but with favorable specimens and using high powers of magnification the lines of vibrating organs can be seen. However, I could not be sure of the observation nor of the nature of the organs without recourse to sections, which showed the cilia and their arrangement with sufficient clearness. (See text figures 5 and 6.) The ends of the rows of endoral cilia may extend upon the anterior wall of the pharynx. (See text figure 6.)

I have since found the suboral group of membranellæ and the endoral cilia in another unidentified species of Euplotes, and therefore venture to suggest the possibility that these structures may be found in still other species of the genus. The praeoral cilia of *E. harpa* described by Wal-lengren are different in position and arrangement from both the suboral membranellæ and the endoral cilia of *E. worcesteri*. They may, however, be homologous to the endoral cilia.

The extreme shortness of the pharynx is a noticeable feature in most of the Hypotricha. The organ reaches its greatest development in the Euplotidae, especially in the genus Euplotes. The pharynx of *Euplotes worcesteri* is longer than that of any other Euplotes known; however, that of *E. vannus* is only slightly shorter. In other species of the genus the length of the pharynx is much less. The forward curvature of the pharynx of *E. worcesteri* and *E. vannus* also is remarkable among Hypotricha.

The adoral and pharyngeal membranellæ and the endoral cilia are in nearly constant motion. In addition to gathering food particles the anterior adoral membranellæ appear to be the principal natatory organs of the animal. The suboral membranellæ, on the contrary, are apt to be found at rest except when food is being swallowed. These membranellæ appear to be triangular. The small area covered by them is oval in outline, its axis obliquely inclined to the ventral edge of the oval aperture. The tips of the outermost membranellæ project slightly from the mouth, and just clear the tips of the adoral membranellæ. Direct observation, many times repeated, has proved that food particles which arrive at the mouth are seized between the adoral membranellæ above and the suboral below, and forced into the pharynx.

That the thrusting power of the two sets of membranellæ is considerable was shown one day when I observed a Euplotes which had captured and was trying to swallow a small *Lembus* rather more than one-half as

long as itself. When first seen the Euplotes had the anterior end of the Lembus in its pharynx. The Lembus was alive and struggling; several times it was forced along the pharynx and its tip entered the protoplasm of the Euplotes; once nearly one-half its body was in the endosarc of its captor. However, each time it forced its way back, and finally escaped altogether from the Euplotes and moved away giving no evidence of having received any harm. On another occasion a Euplotes was found in the act of swallowing an amoeba of elongated form. A little less than one-half of the body of the amoeba then lay in the pharynx, completely filling about two-thirds of this organ, and blocking the membranellæ so that none of them could act. As a result, after a few efforts the amoeba reversed the direction of its motion and crawled out of the pharynx, across the adoral zone, and away. I have frequently observed that small protozoa and bacteria are thrust into the mouth between the adoral and suboral membranellæ and then are pushed along by the pharyngeal membranellæ and cilia; currents of water, conveying food particles from the mouth to the tip of the pharynx, do not appear to exist. A similar conclusion was recently reached by Schäffer regarding the process of swallowing in Stentor.

The function of the endoral cilia is more difficult to understand than that of the suboral membranellæ, because direct observations are almost impossible. Large food bodies which reach the mouth are grasped easily between the two sets of membranellæ. In the case of small particles, like bacteria, the process may be different. Only those which reach the mouth at the level of the tips of the adoral membranellæ will be seized in the manner described. Those which lie in a lower, i. e. more ventral, level will pass over the posterior wall of the peristome with the currents of water. Those which arrive at the dorsal part of the oral aperture will be brought within reach of the endoral cilia and pushed along to the tip of the pharynx. If the Euplotes lies with its dorsal side up, the particles captured by the endoral cilia may fall out of their reach to the ventral side of the pharynx, but there they will be pushed along by the tips of the pharyngeal membranellæ. However, if the Euplotes is swimming with the ventral side up as is frequently the case, the particles captured by the endoral cilia will be thrust along by them until the inner tip of the pharynx is reached. In addition, the inclined position of the pharyngeal membranellæ is such that, with the animal in this position, any particles which escape from them will drop directly upon the endoral cilia and will also be passed down the pharynx. The pharyngeal apparatus of Euplotes is, therefore, a remarkably efficient one.

On the other hand, if we view the adoral zone of membranellæ as a mechanical food conveyor alone, its efficiency is very low, for the currents produced by it are so strong that nearly every particle drawn into the peristome is thrown out again over the posterior border at a high speed.

A very low percentage of particles is thrown into the angle where the mouth is located and large numbers of these eventually are lost. However, the adoral zone is more than a food conveyor, it is also the principal organ of locomotion; a balance of functions exists such that an increase of efficiency in either direction without other modifications would be fatal.

This *Euplotes* appears to be selective in its feeding, if tests made with carmine are of any value, for I have seen but one specimen which swallowed any carmine granules, and that one took only a few. While bacteria were being swallowed in large numbers, the carmine grains were swept out of the peristome as if the animal were unconscious of their existence. The experiment has been repeated several times and some hundreds of *Euplotes* observed. It is noticeable also, that when several kinds of food are present in an infusion one kind appears to be preferred, as is proved by the nature of the food masses in the bodies of the infusorians.

Minute food particles are collected in the form of a dense ball at the inner end of the pharynx before being swallowed, as in many other infusorians. Room for this is provided, not in the pharynx itself, but in an evagination of the anterior side, projecting into the endosarc, and increasing in size as the food mass grows. Text figure 5 shows an early stage of the evagination, and a later stage is represented in Plate V, figure 10. When the ball is finally ingested no visible layer of water accompanies it.

Membranellæ.—The number of adoral membranellæ varies between 45 and 70. The anterior ones are strikingly long. (Plate I, figure 1.) Passing toward the mouth, a gradual reduction in length occurs so that near and at the mouth they are able to swing freely within the edges of that opening.

Minkiewicz describes the adoral membranellæ of *E. vannus* as triangular, and Wallengren represents those of *E. harpa* as of a similar shape. After repeated examination I am convinced that the shape of the expanded membranella of *E. worcesteri* is nearly rectangular, about as shown in Plate I, figure 1. However, some are longer on the outer than the inner side, while very frequently during action the membranellæ assume a triangular shape by the inner side being drawn toward the outer. The membranellæ of this genus are extremely flexible organs, showing but little modification from the condition of free cilia.

The membranellæ of this species, even in the living condition, do not appear to be homogeneous. As soon as the motion of these organs slows in a captured specimen, each membranella appears to consist of a double row of delicate cilia, closely set, and moving exactly together but without any visible uniting substance.

After fixation and staining, no matter what the method, the appearance

of separate cilia is even more definite. Even where the membranelle appear to be changed only slightly by the fixation, the cilia of which they are composed are all perfectly distinct and separate. There are no places where a few appear to be fused in a plate, lying regularly and parallel as one would expect to find if the membranelle were definite protoplasmic plates. Each cilium can clearly be traced from basal granule to tip, as a separate and distinct unit. The individuality of the cilia is well shown by sections cutting the membranelle above their bases.

It may be that during life there exists a film of protoplasm joining the cilia, too delicate to be seen, and destroyed by the slightest disturbance of normal conditions. I have seen the separate cilia of the membranelle so many times in the living animal where there seemed to be very little disturbance of conditions, that I am inclined to believe that the membranelle of this form are composed of distinct cilia with movements so perfectly coördinated that they act and ordinarily appear as a single and delicate blade. Möbius also came to the same conclusion.

The view held by the majority of zoölogists is that the membranelle are formed by the fusion of cilia. This *Euplotes* shows the individual cilia better, with less fusion, than the majority of other forms which have been studied. Instead of arguing from the appearances produced by certain reagents, one or two structural characters, and the general probabilities of development, we here are able to see the units of which the organ is composed in the living specimen. This is true of both adoral and suboral membranelle.

Each membranelle of the adoral zone occupies the middle of a shallow groove crossing the zone. The bases of the cilia of the membranelle are united by a slightly elevated ridge of the ectosarc. The basal ridge stains more deeply than the surrounding protoplasm. At the base of each membranelle lies an irregularly double row of large basal granules, a single granule for each cilium.

Cirri.—The arrangement and location of the cirri need no special description, variation from that shown in Plate I, figure 1, being infrequent except for one group. The small cirri shown on the right posterior margin are frequently altogether absent, and when present they may be either one, two, or three in number.

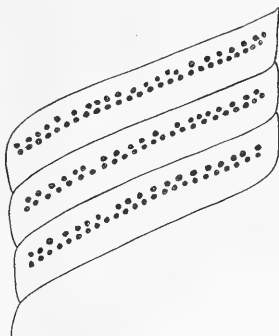

FIG. 7.—Basal granules of three adoral membranelle and the outlines of the grooves about their bases.

The feature of most interest in regard to the cirri is the ease with which the individual cilia of which they are composed may be demonstrated. After the *Euplotes* have been confined for only a few minutes under a cover-glass, the tips of the cirri become frayed, and a little later the entire cirrus has changed to a brush of strong cilia which may either beat as a unit, or each cilium may move independently.

All reagents cause the cirri to break more or less into their ciliary elements, while a change in the density of the water will cause them to

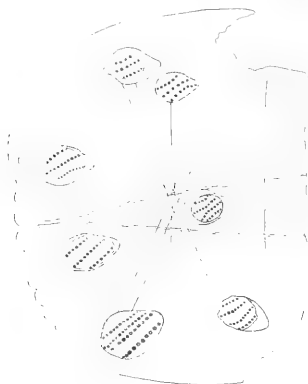

FIG. 8.—Camera lucida sketch of a tangential section of the ventral surface, showing the rows of basal granules and some of the contractile fibrils of the cirri.

brush instantly and most markedly of all, though the animal may still be alive. Each of these cilia is connected with a basal granule. (Text figure 8; Plate III, figure 8.) The basal granules lie in a plate of specially dense and stainable, nongranular ectosarc. (Plate III, figure 8.)

On examining tangential sections of the ventral surface of the body, it was found that the basal granules of each cirrus are arranged in several parallel rows (text figure 8), the rows being slightly oblique to the axis of the body. That the cirri are composed of bundles of fused cilia has been believed for many years. This last observation indicates, in addition, that each

cirrus has developed, not from a single row, but from several of the rows of cilia which we may imagine to have covered the body of the ancestral form. It has been difficult to reconcile this theory with the observations of Stein and Sturki that the new cirri of *Stylonichia* arise from portions

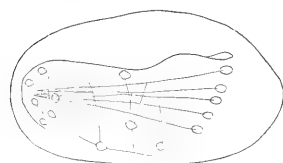

FIG. 9.—Contractile fibrils of the cirri, drawn from an unstained specimen fixed in corrosive-formol-acetic, followed by alcohol.

of a delicate undulating membrane. My own observations of the development of cirri in *Euplotes worcesteri* lead me to believe that this objection is not serious. (See Part II.) In addition Wallengren observed that in *Euplotes harpa* and *Stylonichia* the rudiments of the cirri appear separately.

In connection with the bases of the cirri are certain endoplasmic fibers. (Plate II, figure 4; text figure 9; Plate III, figure 8.) A fiber passes forward from the base of each anal cirrus, the five fibers gradually

converging until they end close to each other at the anterior extremity of the ventral surface. Occasionally they seem to unite as described by Maupas, but I do not find this condition so frequently as the other. These fine fibrils are much larger and more readily seen than the fibrils of the other cirri. I have never seen in one specimen so many fibrils as Prowazek shows in his figures of *E. harpa*. The fibrils of the anal cirri are seen easily in the living animals, and they become quite conspicuous after staining with aceto-carminé. They are not as easily seen in sections, because of the difficulty of cutting sections exactly parallel with their course.

Plate II, figure 4, represents the fibrils seen in a living animal; text figure 9 shows others seen after fixation, but without staining. Plate III, figure 8, is a drawing of a section stained with iron-hæmatoxylin.

From these figures it will be seen that the fibrils could not be traced from the base of every cirrus, and that different arrangements were found in different specimens. In general it may be stated that the fibrils seemed to be most developed in connection with the strongest or most used cirri.

The fibrils lie just inside the ectosarc, or it might be better to say in the inner layer of ectosarc. Each ends in the basal plate of dense protoplasm under the cirrus. They appear to be round in cross-section.

It also will be noticed from the figures that more than one fibril is connected to several of the frontal and abdominal cirri. I have never seen more than the single fibril for each anal cirrus. If the fibrils are contractile, as seems altogether probable, they are developed around the bases of the cirri in such directions as to assist in producing the ordinary motions. As the anal cirri have only a single strong motion, a vigorous kick directed backward, each needs but a single strong fibril. The movements of the other cirri are more varied and consequently the fibrils are more numerous. It may be that such fibrils are connected with all the cirri, but only a few are visible in any specimen; or it is possible that the ordinary contractility of the ectosarc is sufficient to produce the movements of the smaller cirri and that no specialized fibrils exist.

In this connection the fact may be mentioned that the two left marginal cirri (back of the peristome) do not have the striking or kicking motion of the others, but lash rapidly and forcibly with a spiral motion.

Engelmann noticed that a very fine plasma-thread arises from each marginal cirrus of *Stylonichia*, which can be followed close to the ventral surface nearly to the mid-line of the body. Maupas repeated this observation and also discovered the fibrils of the five anal cirri of *Euplotes*. The anal cirri of *Stylonichia* possess similar fibrils. Engelmann suggested that the fibrils were nervous in function, radiating from a common nerve center, but Bütschli believed them to be similar to the intracellular

fibrils of ciliated metazoön cells, and probably contractile; this is much the more reasonable view. Every detail of arrangement and structure indicates that the fibrils are, principally at least, contractile in function. A relation with the myonemes of other Ciliata suggests itself immediately; and, if each cirrus represents the highly developed and specialized remnant of several rows of cilia, it seems possible that some of the myonemes of these rows may have remained and developed accordingly. The objection to this theory is twofold: first, that many of the fibrils run in directions which bear no relation to the hypothetical original ciliary rows; and, second, that while each cirrus has several rows of basal granules, the fibrils do not correspond to these rows.

Sensory bristles.—The Hypotricha are commonly described as having numerous immotile bristles on the dorsal surface, which probably are the modified vestiges of a once close ciliation (see Bütschli, Döflein, et al.). A sensory function is ascribed to them, and the name of sensory bristles will be adopted here without questioning the correctness of its application.

I find that *Euplotes worcesteri* possesses not only the usual dorsal bristles, but also several rows and definitely arranged groups of ventral bristles. The bristles of this *Euplotes* are extremely short and transparent, rendering direct observation most difficult; but as the base of each bristle is usually surrounded with refringent ectosarcal granules, their positions can easily be seen. Plate II, figure 3, is drawn from a specimen in which the bristles were unusually clear. The tips were bluntly pointed, while the bases were expanded. The shape is decidedly different from that of the bristles heretofore described in various Hypotricha by other observers, and from the bristles of other species of Euplotidæ which I myself have observed. The bristles of the ventral surface are even smaller and more difficult to observe than the dorsal ones. I find no record of any previous observation of these ventral sensory bristles, although Stein saw the granules which surround their bases along the sides of the adoral zone of membranellæ in *Euplotes charon* O. F. M. These observations have been repeated many times, and careful examination has been made on numerous occasions to determine that a bristle stood at the center of each group of granules. As the granules are so easily seen, and the bristles are distinguished only with difficulty, there was manifestly some danger of assuming that each group of granules necessarily indicated the position of a bristle. The bristles of the dorsal surface usually lie in eight longitudinal rows, although six, nine, or ten rows are found. It happens that Plate II, figure 3, is drawn from the only specimen I have ever seen having six rows.

Upon the ventral surface the bristles are always arranged as follows: First, there are several bristles about the base of each cirrus; usually four, occasionally six, at the bases of the large cirri, and two or three beside the smaller ones. (Plate II, figure 4.) Second, there is a row of bristles on each side of the adoral zone of membranellæ; with few

exceptions a bristle stands opposite either end of each membranella. Third, a short row of larger bristles lies along the posterior half of the left margin. These bristles are of about the same size and are spaced about the same as the bristles of the dorsal surface. The arrangement of these sensory bristles of the ventral surface gives further support to the view that the bristles are modified cilia. The resemblance between the row of bristles on the inner side of the adoral zone to what some authors call the paroral or preoral cilia of forms such as *Stylonichia* and *Urostyla* is obvious. The outer row of bristles evidently represents a marginal row of cilia.

Pellicle.—The body is covered by a thin tough pellicle which is usually very difficult to distinguish from the outer layer of protoplasm. Some specimens, after treatment with a modification of the Golgi method, show a quite regular network of wrinkles in the pellicle. On another occasion an accident in focusing caused the breaking and partial crushing of a number of stained specimens. The pellicle was then easily distinguished where it projected beyond the protoplasm at broken edges, and also where it had shrunk and wrinkled on the surface of the body as soon as the slight tension to which it had been subjected was relieved. The pellicle is extremely clear and transparent, and shows no structure.

The cirri project through openings in the pellicle which are a little larger than the bases of those organs, leaving a narrow space around the base of each cirrus where the protoplasm is unprotected. In one of my cultures great numbers of small amœbæ appeared, and I then observed several *Euplotes* which were attacked by the amœbæ, the latter thrusting part of the body into the *Euplotes* through the unprotected space at the base of a cirrus, while half or more of the body remained outside.

Ectosarc (Plate III).—The ectosarc forms a very definite layer of considerable thickness, which can be distinguished easily in both living and stained specimens. The marked feature of the ectosarc is a single layer of large alveoli filled with clear, homogeneous, and apparently fluid substance. These alveoli, viewed from the surface, give the ectosarc very much the appearance of being composed of cells. (Plate III, figure 7.) The walls separating the alveoli are usually very thin, but may contain smaller alveoli of similar nature. Their depth is in most cases almost the thickness of the ectosarc, although it is not uncommon to find two layers of smaller alveoli. The contents of the alveoli stain with Lyons blue, while the walls do not; Lyons blue used in combination with acetic-carmin gives a very sharp picture of the alveolar structure of the ectosarc. The contents of the alveoli do not shrink, nor stain with iron-hæmatoxylin. The alveoli and their contents are evidently of an entirely different nature from the ectosarc vacuoles and granules described by Metcalf although they have much the same appearance. Between the ends of the alveoli and the pellicle is a thin layer of protoplasm, which may contain other very fine alveoli.

The radiating granules about the bases of the sensory bristles have been mentioned. There are several references in the literature to these structures, which appear to be peculiar to the Euplotidæ, and the questions of their nature and exact location are still unsettled. The granules have been observed by Dujardin, Claparede and Lachmann, Stein, Rees, Stokes, and recently by Minkiewicz. Rees suggested that they might be vacuoles, possibly contractile. Bütschli considered that they were more likely to be pellicular formations. Minkiewicz denies that they can be pellicular, or vacuoles; his statement is that they are "probably" crystalline, and "probably" lie between the ectoplasm and endoplasm.

The granules are extremely variable in size, although those of the ventral surface (excepting those of the lateral row) are always much smaller than those of the dorsal. The granules along the sides of the adoral zone are smallest of all.

The granules are always longer than broad, sometimes three or four times so; colorless, refringent, and crystalline in their appearance. No angles are visible, all sides and the ends apparently being smooth and rounded. The largest granules of the dorsal surface may be $1\ \mu$ by $2\ \mu$. More commonly the length is three or four times the width. The smallest ones are not more than one-quarter the size of the larger. The granules of the ventral surface, except those of the lateral row, are rarely more than $1\ \mu$ in length, and usually about $\frac{1}{2}\ \mu$.

The granules always lie around the bases of the sensory bristles, on both the upper and lower surfaces, arranged radially with the base of the bristle as a center. The central ends of the granules are also directed toward the surface of the body, giving a conical form to the group. In many instances the pellicle is actually elevated a trifle over the group of granules, which fact has caused Stokes to interpret them as appearances due to star-shaped elevations of the surface instead of real bodies.

The number of granules in a group varies greatly, but the largest groups are always found on the dorsal surface, while the smallest are seen in the rows beside the adoral zone. In the former there are frequently as many as a dozen granules, while the latter rarely contain more than four very small ones, and frequently only one or two. There is surprisingly little irregularity in the position of these groups of granules. Very rarely one observes a few irregular groups in the center of the ventral surface, but nowhere else.

The granules lie in the outer layer of ectosarc, immediately beneath the pellicle. They are not pellicular structures, as Bütschli considered them, neither do they lie between the ectosarc and endosarc. The presence of the large ectosarc alveoli makes it possible to determine the position of the granules by focusing in either living or stained material, and I have also found a few in sections.

The suggestion of Rees that the groups of granules are vacuoles,

possibly contractile, has nothing to commend itself to further consideration.

The granules are not dissolved by strong or dilute acetic, hydrochloric, or nitric acids, nor by absolute or dilute alcohol. Gram's solution of iodine and potassium iodide causes no change of color either in the cold or after heating. No change of color occurs after treatment with iodine, heating, and addition of strong sulphuric acid. Dilute osmic acid blackens the granules instantly. Absolute alcohol used after osmic acid does not dissolve them; absolute alcohol and ether, after treatment with osmic acid, dissolves the granules.

From these tests it seems to be clear that the granules are fatty in their nature. The animals of depressed or starving cultures sometimes have few or none of these granules, while in vigorous cultures all the Euplotes have very numerous and well-developed ones. It appears then to be a fair conclusion that these peculiarly arranged granules of the ectosarc constitute a supply of reserve fatty food-substance.

Endosarc.—The endosarc presents a most irregular structure, differing according to the condition of the animal, whether full fed or starved, and the nature of the food. It is well to remember that a large part of what is commonly called endosarc is a mechanical mixture of protoplasm, food in various stages of digestion, water, and indigestible particles or excreta. In addition to the finely granular protoplasm which sections always show, the endosarc of this Euplotes contains great numbers of fibers. These are visible when the protoplasm has been crushed and torn during the process of sectioning and mounting. The constant motion of the central portion of the endosarc prevents there being any definite visible structural relation here.

The animals of well-fed cultures usually show large numbers of rounded, ovoid, or spherical granules, which are highly refringent, and form a conspicuous feature of the living endosarc. These spherules are unchanged by osmic acid, and are not dissolved by alcohol or ether, nor by the two together, but they are dissolved instantly by very weak solutions of nitric and hydrochloric acids and by strong acetic acid. They appear, therefore, to be a sort of calcareous concretion, bearing a certain resemblance to the crystals of calcium orthophosphate found in the endosarc of Paramœcium.

Ingestion and egestion.—The formation of a ball of food and its passage into the protoplasm is very much the same in Euplotes as in such a form as Paramœcium, except that there is no visible layer of water surrounding the food; no *food-vacuole* can be observed inside the body. The food mass appears to be in direct contact with the protoplasm, and while undoubtedly some water is swallowed with the food, there is not enough of it to be visible.

After entering the body the food mass is caught up by the circulating stream of protoplasm, which carries it forward, and then in a circle,

counter clock-wise, for numerous small revolutions about the central region of the body. The cyclosis is continual but irregular in rate, and much more restricted in extent than in most large ciliates. The endosarc of the edges and anterior and posterior extremities of the body seems to be very stable.

The place of egestion is immediately behind the outermost anal cirrus, on the ventral surface. Frequently large quantities of indigestible material accumulate in the body before egestion takes place. Then the balls of ejecta are pushed out with considerable force, at intervals of a few seconds, until all is disposed of. The slowness with which the masses of ejecta are at first pushed through the surface of the body, until the largest part passes the pellicle, and the suddenness and force with which they then are shot away, indicate that the pellicle around the anus is highly elastic and that the anus is kept closed by its contraction. It appears probable that in those ciliata which possess a definite anal spot, there is also a real canal in the protoplasm, ordinarily kept closed and invisible by the elasticity of its walls and the pellicle.

As the anus lies just in front of the contractile vacuole, the masses of ejecta often press against its walls. In some cases the masses of undigested material accumulate to such an extent as actually to be forced into the contractile vacuole and cause it to become enormously distended; but in most cases this organ is only crowded to one side and partially surrounds the mass of waste material, the appearance that ejecta are inside the vacuole being deceptive.

Contractile vacuole.—The position of this organ is shown by Plate I, figure 1. When fully formed the vacuole is rather large. The pulsations occur at unusually long intervals. Because of the slowness of the process it is difficult to watch the entire cycle in an animal active enough to make the observer sure that it is in a normal condition. I find that the time required for the complete cycle averages twelve minutes. If, as has been suggested, a principal function of the vacuole is to force out of the body water which is continually being taken in with the food particles, the long period of the vacuole of *Euplotes* may very well be due to the extremely minute quantities of water absorbed with the food. The length of time required for a cycle of the contractile vacuole in this species is the more remarkable since Rossbach gives 31 seconds as the period of *Euplotes charon* O. F. M., and Maupas 50 seconds as that of *E. patella* O. F. M. I find no statement concerning the contractile vacuole of *E. vannus* O. F. M. in the summary of Minkiewicz's paper. It is possible that in this genus we have an opportunity to test the theory of a relation between the amount of water swallowed with the food and the activity of the contractile vacuole. Another indication of the low activity of the contractile vacuole of this species is in the fact that at any time large numbers of healthy animals show no vacuole at all. Out of twenty which were carefully examined at one time, the examination of each requiring

about one minute, thirteen showed no vacuole, while in some of the remaining seven which had vacuoles, these were very small. In a less careful examination the contractile vacuole was visible in only four out of fifty, but I afterwards found that the vacuole is so minute for some minutes as to be nearly invisible even with high powers.

The contractile vacuole in Euplotidæ is said to open upon the ventral surface of the body beside or in front of the anus, but I have not been able to make any observations regarding this point, except to be certain that it does not open in front of the anus in *E. worcesteri*.

Nuclei.—The shape of the meganucleus is shown by text figure 10. The enlargement of the posterior end, reminding one of an anchor-fluke, is a most characteristic feature of this species of Euplotes. While it is subject to variation, so that the enlargement is not of exactly the same size nor shape in any two specimens, the general form is almost always the same, and so marked as to constitute one of the diagnostic characters of the species. Minkiewicz represents (text figure 13) the corresponding end of the meganucleus of *E. vannus* O. F. M. as turned back upon itself, but not enlarged. It does not seem possible that there could be a mistake in so simple an observation. The difference in the shape of this part of the meganucleus forms a very convenient means of distinguishing the two species, which otherwise are much alike.

The portion of the nucleus which crosses the anterior end of the body is also considerably thickened and the anterior margin is frequently irregular.

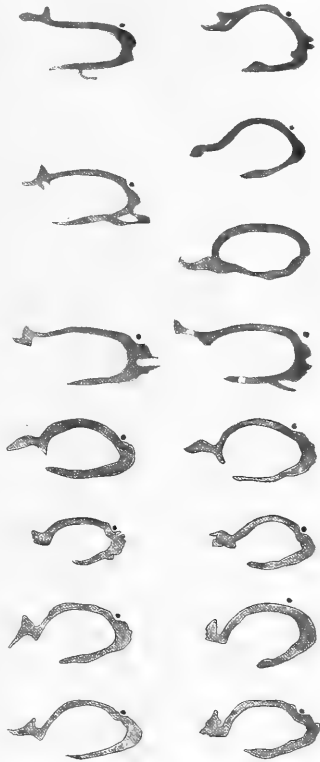

FIG. 10.—Various shapes assumed by the meganucleus of *Euplotes worcesteri* n. sp.

The meganucleus lies close to the ventral surface of the body. In order to pass the pharynx, it bends over the dorsal side of this organ, as shown in text figure 11.



FIG. 11.—Lateral view of *Euplotes worcesteri* showing the curvature of the meganucleus over the pharynx.

The chromatin of the meganucleus is arranged in a fine reticulum, as is shown by Plate IV, figures 1, 2, 3, and 4. It is generally found that the fibers of the reticulum on the anterior side of the anterior enlargement of the meganucleus are greatly attenuated, causing that part to appear less deeply stained than others. The nucleus is rarely visible in living animals. If the *Euplotes* are in a very clear, transparent condition, the meganucleus can sometimes be seen and its structure examined with an immersion lens. Under these circumstances the granular reticulation and clear, fluid ground-substance can be seen, the structure appearing the same as in the stained specimens.

At times when division is common and the animals seem to be well nourished and normal in every way, the interior of the nucleus of many animals becomes vacuolated. The vacuoles increase in size until all the protoplasmic portion of the nucleus is crowded into a layer along the nuclear membrane, while the interior consists of one or several large vesicles of clear fluid. It is only when in this condition that the nucleus is easily visible in the living animal. As the vacuoles increase in size

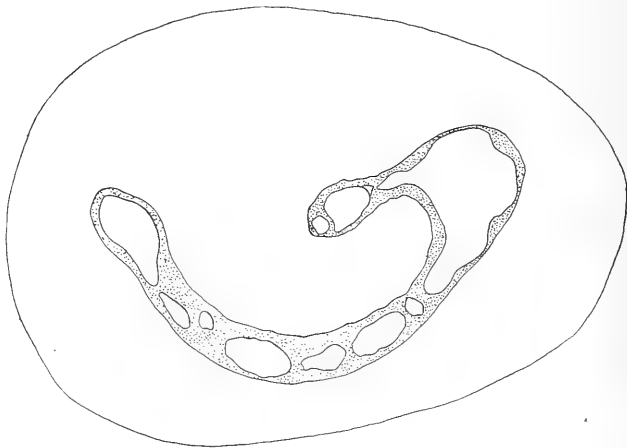

FIG. 12.—Sketch of a vacuolated meganucleus, drawn from the living animal.

the nucleus shortens and becomes thicker. The thickening may take place only around the vacuoles, while the intervening portions become drawn out into fine connecting threads, which finally break. Division may begin during this vacuolated condition of the meganucleus, but apparently does not proceed to a normal conclusion.

The micronucleus (Plate III, figure 9) is single, lying in or near a shallow depression on the left side of the meganucleus. I believe that the forms possessing two micronuclei, which are very common at times, belong to a stage following conjugation.

The micronucleus contains a sparse reticulum of chromatin. (Plate IV, figures 1, 2, 3.) Ordinarily the entire micronucleus stains uniformly, but with careful extraction of the stain the reticulum is rendered visible. If extraction is not quite sufficient, the micronucleus appears homogeneous, as if composed of a uniformly staining colloid substance.

Systematic position.—In order to distinguish *Euplotes worcesteri* from *Euplotes vannus* O. F. M., one must depend largely upon the careful work of Minkiewicz for exact knowledge of the structure of the European form. In the shape of the body, and in the number, form, and arrangement of the cirri, the Philippine form is exactly like the European.

Euplotes worcesteri has a longer pharynx than *E. vannus* O. F. M. and twenty to thirty membranellæ inside the pharynx instead of eight. Both the length of the pharynx and the number of pharyngeal membranellæ vary, but I have always found the number of these membranellæ to be more than double that given for *E. vannus* by Minkiewicz.

Minkiewicz presents one figure showing ten rows of sensory bristles on the dorsal surface of *E. vannus*. I find that most specimens of *E. worcesteri* have eight rows, although six, seven, nine, or ten rows are sometimes found. As there may be considerable variation in the number of these rows in *E. vannus* also, we are not justified in considering the apparent difference between the species in this regard as a valid specific distinction.

The most important difference, and the one upon which the diagnosis of the species really depends is in the shape of the posterior end of the meganucleus. As may be seen by referring to text figure 13 this end of the nucleus is enlarged in a very characteristic manner. Minkiewicz gives six figures of the meganucleus, all of which represent its end as being turned back upon itself, without any enlargement.

(Text figure 13.) The general appearance produced is much the same as is seen in *E. worcesteri*, but the structure is entirely different.

Whether differences exist in the arrangement of the ventral sensory



FIG. 13.—Drawings of the meganuclei of *Euplotes vannus* O. F. M., copied from Minkiewicz (Plate II, figure 23).

bristles can not be said until *E. vannus* has been reëxamined with especial regard to these structures. The same is true of the suboral membranellæ and rows of endoral cilia.

The principal specific characters of *Euplotes worcesteri* are the following: Body oval, anterior end rounded, posterior end bluntly pointed; dorsal surface considerably elevated, with a regular curvature; anterior half of right margin usually straight; body 72 μ to 93 μ in length, 47 μ to 60 μ in width. Ventral surface flat; peristome considerably excavated and broad, extending two-thirds the length of the body, containing 45 to 70 wide membranellæ; mouth irregularly oval, large; pharynx long, recurved, containing 20 to 30 membranellæ, several oblique rows of endoral cilia, and a group of suboral membranellæ; 7 frontal cirri, 3 abdominal cirri, 5 anal cirri, 2 left marginal cirri, 0-3 right marginal or caudal cirri; sensory bristles of the dorsal surface usually in eight longitudinal rows; on the ventral surface paroral, exoral, and lateral rows of sensory bristles, and two to four bristles at the base of each cirrus. Meganucleus long, horseshoe-shaped, with a fluke-like enlargement at the posterior end and a considerable thickening where it bends across the anterior end of the body. Micronucleus single, lying in a slight depression of the meganucleus, on the left side near the anterior end of the body.

The dimensions of ten specimens of *E. worcesteri*, selected at random, are:

Specimen No.	Dimen- sions.	Specimen No.	Dimen- sions.
	<i>Microns.</i>		<i>Microns.</i>
1.....	76 × 47	8.....	85 × 60
2.....	85 × 60	9.....	81 × 56
3.....	93 · 60	10.....	76 · 51
4.....	72 · 47		
5.....	85 · 56	Average size.....	82 · 54
6.....	76 · 47	Least size.....	72 · 47
7.....	89 · 60	Greatest size.....	93 · 60

ILLUSTRATIONS.

PLATE I.

Ventral view of *Euplotes worcesteri* sp. nov. Numerous refringent endosarc spherules are visible, as well as three food-masses.

PLATE II.

FIG. 2. View of *Euplotes worcesteri* from the left side.

3. The dorsal surface of *Euplotes worcesteri* showing the sensory bristles and radiating fatty granules.
4. The ventral surface of *Euplotes worcesteri* showing the positions of the sensory bristles, the radiating fatty granules, and the contractile fibrils running to the bases of the cirri.

PLATE III.

FIG. 5. A longitudinal section of *Euplotes worcesteri*. Camera lucida drawing; Zeiss compensation-ocular 6 and obj. $\frac{1}{2}$. At the anterior end the slight overhang of the dorsal surface and the marginal lamella are shown. The section passes just medially to the inner wall of the persistome and mouth, cutting the pharynx, in which are seen the pharyngeal and suboral membranellæ. The meganucleus is cut in two places. The smaller black bodies are nuclei of small flagellates eaten by the *Euplotes*. The grouping of food-bodies is characteristic.

6. A portion of the ectosarc in vertical section. Within the ectosarc alveoli is a portion of endosarc, and a large food-body. The contents of the ectosarc alveoli usually do not stain. Camera lucida drawing.
7. A tangential section of the ectosarc. Camera lucida drawing.
8. A section through one of the anal cirri, its basal plate, and its contractile fibril. The cilia of the cirrus are in the usual twisted condition. Camera lucida drawing.
9. A micronucleus, stained with iron-hæmatoxylin; stain almost completely extracted, bringing into view the faint chromatin reticulum.

TEXT FIGURES.

- FIG. 1. Outline sketches of three of the deformed individuals which appear when cultures have passed their prime. Specimen A seems to be the result of an aborted division.
2. A cross section passing through the mouth, the adoral membranellæ, *a. o.*, and the suboral membranellæ, *s. o.*
 3. Cross section passing through the mouth, the suboral membranellæ, the pharynx and pharyngeal membranellæ, and the adoral zone.
 4. A longitudinal section, showing the antero-ventral groove of the pharynx.
 5. A tangential section passing through the dorsal wall of the pharynx. The rows of basal granules of the pharyngeal membranellæ and of the endoral cilia show the arrangement of these organs.

- FIG. 6. Part of a longitudinal section passing just inside the mouth. *s. o.*, suboral membranellæ; *e. o.*, endoral cilia, which in this section are well down on the anterior wall.
7. Basal granules of three adoral membranellæ and the outlines of the grooves about their bases.
 8. Camera lucida sketch of a tangential section of the ventral surface, showing the rows of basal granules and some of the contractile fibrils of the cirri.
 9. Contractile fibrils of the cirri, drawn from an unstained specimen fixed in corrosive-formol-acetic, followed by alcohol.
 10. Various shapes assumed by the meganucleus of *Euplotes worcesteri*.
 11. Lateral view of *Euplotes worcesteri* showing the curvature of the meganucleus over the pharynx.
 12. Sketch of a vacuolated meganucleus; drawn from the living animal.
 13. Drawings of the meganucleus of *Euplotes vannus* O. F. M., copied from Minkiewicz. (Plate II, figure 23.)

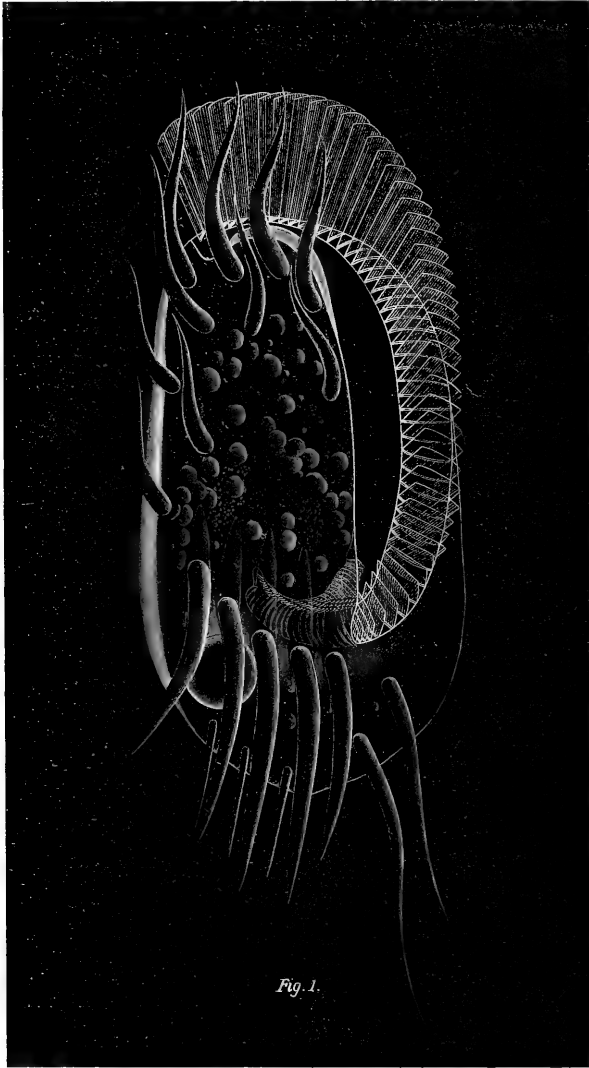

Fig. 1.

L. E. Griffin and T. Espinosa.

PLATE I.

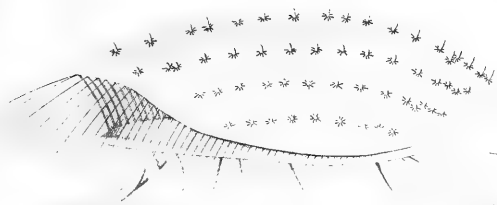

Fig. 2.

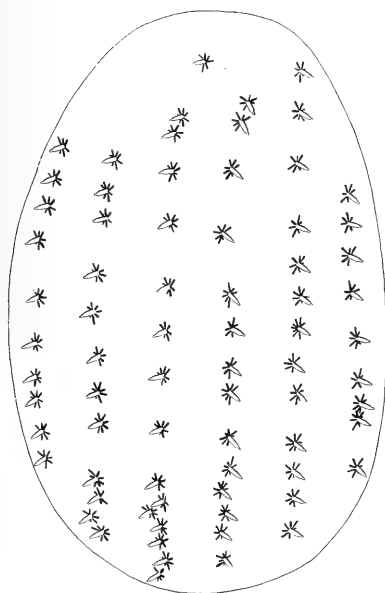

Fig. 3

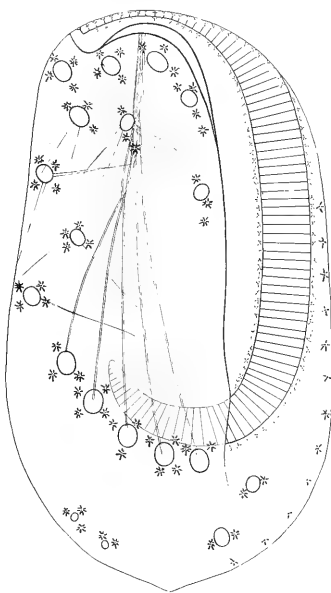

Fig 4

L. E. Griffin and T. Espinosa.

Fig. 5.

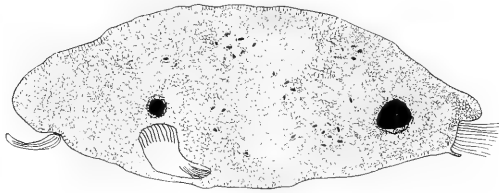
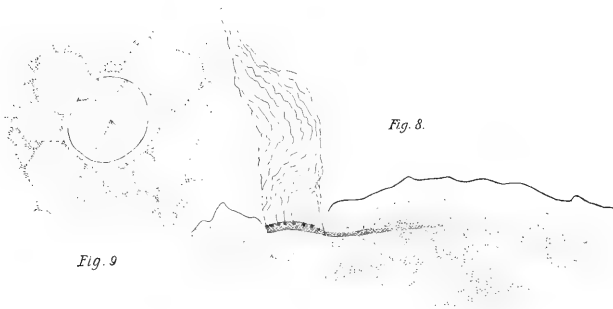
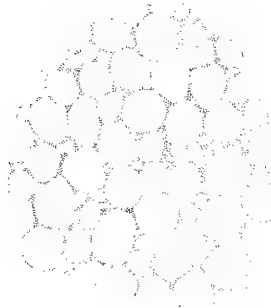

Fig. 6.



Fig. 7.



L. E. Griffin and T. Espinosa.

REVIEW.

Check-list of North American Birds. Prepared by a Committee of the American Ornithologists' Union. 3d ed. revised. Cloth. Pp. 430. Price \$3.50 net. New York: American Ornithologists' Union. 1910.

This welcome and long-promised volume is essentially the second edition of the check-list with the interpolation of the various additions and other changes which have been recorded in the supplements since 1895. The details of geographical distribution, "*range*" in the new check-list, are given in much greater detail than ever before, especial attention having been devoted to defining the breeding and seasonal ranges of species and subspecies. The scientific name and vernacular name of each species, or subspecies, are printed on the same line, followed by the old check-list number. The names of authorities are spelled out. The secondary references and concordance to previous check-lists are omitted, but type localities are given. Names of subspecies are printed in slightly smaller type than those of species and are designated *a*, *b*, *c*, etc. This is perhaps an advantage so long as trinomials are retained, but the reviewer has not discovered the advantages of trinomials. Vernacular names seem to have received but limited attention, the treatment of double names especially being most unhappy. Thus we find Water-Turkey, Wood Duck, Tree-duck, Tree Sparrow, Pintail, Spoonbill, Red-head, Buffle-head, Canvas-back, Tropic-bird, Surf-bird, Catbird, Cowbird.

Two maps, one colored, show the life zones of North America and the localities mentioned in the check-list.

The paper, press work, and binding of the new check-list are very similar to those of the second edition, that is to say, excellent.

R. C. McG.



Order No. 401.

THE BONTOC IGOROT.

By A. E. JENKS.

110 pages. 3 maps. 154 photographic plates. 9 figures.

An interesting study; the result of almost a year's residence among the Bontoc Igorots.

Price \$1 United States currency, postpaid.

Order No. 402.

NEGRITOS OF ZAMBALES.

By WILLIAM ALLAN REED.

62 photographic illustrations. 91 pages.

An interesting ethnological study of the pygmy blacks of Zambales.

Price \$0.25, United States currency, postpaid.

Order No. 403.

THE NABALOI DIALECT.

By OTTO SCHEERER.

TOGETHER WITH

THE BATAKS OF PALAWAN.

By EDWARD Y. MILLER.

199 pages. 1 map. 28 full-page photographic plates. 6 figures.

The result of research work among this interesting tribe of primitive people.

Price \$0.25, United States currency, paper, postpaid.

NOTE.

Orders should be sent to the Business Manager, Philippine Journal of Science, Manila, or to any of the below-listed agents. *Please give Order Number.*

FOREIGN AGENTS.

The Macmillan Company, 64-66 Fifth Avenue, New York City, U. S. A.
Messrs. Wm. Wesley & Son, 28 Essex Street, Strand, London, W. C., England.
Mr. Martinus Nijhoff, Nobelstraat 18, The Hague, Holland.
Messrs. Mayer & Muller, Prinz Louis Ferdinandstrasse 2, Berlin, N. W., Germany.
Messrs. Kelley & Walsh, Limited, 32 Raffles Place, Singapore, Straits Settlements.
Messrs. A. M. & J. Ferguson, 19 Baillie Street, Colombo, Ceylon.

CIRCULARS AND DESCRIPTIVE MATTER SENT ON APPLICATION.

Beginning with Volume V, a new section, "Section D, Ethnology, Anthropology, and General Biology," will be added to the Journal. The price for the whole series to subscribers for 1910 will be as heretofore, \$5 United States currency. Single subscriptions to Section D will be \$2 United States currency.

Beginning with 1911, the price of the entire Journal will be increased to \$7 United States currency. Section D will appear as often as material is available.

CONTENTS.

	Page.
GRIFFIN, LAWRENCE E. <i>Euplotes Worcesteri</i> sp. nov.: I. Structure.....	291
REVIEW.....	313

The "Philippine Journal of Science" is issued as follows:

Section A, Chemical and Geological Sciences and the Industries, \$2 United States currency per year.

Section B, Medical Sciences, \$3 United States currency per year.

Section C, Botany, \$2 United States currency per year.

Section D, Ethnology, Anthropology, and General Biology, \$2 United States currency per year.

The entire "Journal," \$5 United States currency for Volumes II, III, IV, and V. Thereafter, \$7 United States currency per year.

Authors receive 100 copies of their papers free.

Subscriptions should be sent to the Business Manager, Philippine Journal of Science, Bureau of Science, Manila, P. I., or to any of the agents listed below. Please give order number.

FOREIGN AGENTS.

The Macmillan Company, 64-66 Fifth Avenue, New York City, U. S. A.

Messrs. Wm. Wesley & Son, 28 Essex Street, Strand, London, W. C., England.

Mr. Martinus Nijhoff, Nobelstraat 18, The Hague, Holland.

Messrs. Mayer & Muller, Prinz Louis Ferdinandstrasse 2, Berlin, N. W., Germany.

Messrs. Kelley & Walsh, Limited, 32 Raffles Place, Singapore, Straits Settlements.

Messrs. A. M. & J. Ferguson, 19 Baillie Street, Colombo, Ceylon.

Entered at the post-office at Manila, P. I., as second-class matter.

A limited number of unbound copies of previous volumes are available, which may be secured from the Business Manager, Philippine Journal of Science, Manila, P. I., at the following rates: Volume I, 1906 (not divided into sections), \$10 United States currency; Supplement to Volume I, \$3.50 United States currency; Volume I (without supplement), \$6.50 United States currency; all later volumes at current subscription prices.

Vol. V

DECEMBER, 1910

No. 6

THE PHILIPPINE
JOURNAL OF SCIENCE

EDITED BY

PAUL C. FREER, M. D., PH. D.

WITH THE COÖPERATION OF

DEAN C. WORCESTER, A. B.; ROBERT BENNETT BEAN, M. D.
MERTON L. MILLER, PH. D.; CHARLES S. BANKS, M. S.
ALVIN SEALE, A. B.; LAWRENCE E. GRIFFIN, PH. D.
RICHARD C. MCGREGOR, A. B.; NELLIE LOUISE COOK, B. L., M. A.

PUBLISHED BY

THE BUREAU OF SCIENCE

OF THE

GOVERNMENT OF THE PHILIPPINE ISLANDS.

D. ETHNOLOGY, ANTHROPOLOGY, AND GENERAL
BIOLOGY

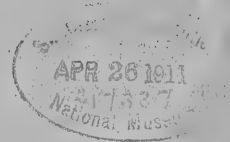
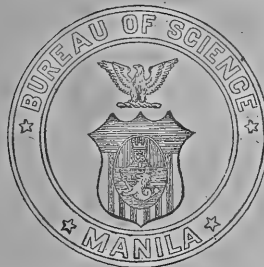

MANILA
BUREAU OF PRINTING
1910

Order No. 405.

STUDIES IN MORO HISTORY, LAW, AND RELIGION.

By NAJEEB M. SALEEBY.

107 pages. 16 illustrations. 5 diagrams.

A treatise on the history and customs of the Moro People.

Price \$0.25, United States currency, postpaid.

Order No. 406.

THE HISTORY OF SULU.

By NAJEEB M. SALEEBY.

275 pages.

A complete History of the Moro People in Sulu, with maps and many translations from the original documents.

Price \$0.75, United States currency, postpaid.

Order No. 410.

MINDANAO.

THE SUBANUNS OF SINDANGAN BAY.

By EMERSON B. CHRISTIE.

122 pages.

Profusely illustrated.

This, together with the History of Sulu and the Studies in Moro History, Law and Religion, is one of an authentic and valuable set of works on the origin, history and customs of these tribes, who are among the most interesting peoples of the world.

Price \$1.25, United States currency, postpaid.

NOTE.

Orders should be sent to the Business Manager, Philippine Journal of Science, Manila, or to any of the below-listed agents. *Please give Order Number.*

FOREIGN AGENTS.

The Macmillan Company, 64-66 Fifth Avenue, New York City, U. S. A.
Messrs. Wm. Wesley & Son, 23 Essex Street, Strand, London, W. C., England.
Mr. Martinus Nijhoff, Nobelstraat 18, The Hague, Holland.
Messrs. Mayer & Müller, Prinz Louis Ferdinandstrasse 2, Berlin, N. W., Germany.
Messrs. Kelley & Walsh, Limited, 32 Raffles Place, Singapore, Straits Settlements.
Messrs. A. M. & J. Ferguson, 19 Baillie Street, Colombo, Ceylon.

CIRCULARS AND DESCRIPTIVE MATTER SENT ON APPLICATION.

THE PHILIPPINE
JOURNAL OF SCIENCE

D. ETHNOLOGY, ANTHROPOLOGY, AND
GENERAL BIOLOGY

VOL. V

DECEMBER, 1910

No. 6

EUPLOTES WORCESTERI SP. NOV.: II.¹ DIVISION.

By LAWRENCE EDMONDS GRIFFIN.²

The literature on division in the family of the Euplotidæ is surprisingly limited, considering its wide distribution, the ease with which observations can be made upon several of the species, the interesting processes involved, and the number of competent naturalists who have made observations on the group. The only important paper dealing with this subject is the excellent article of Wallengren upon the processes of construction and resorption occurring during division in the Hypotricha; *Euplotes harpa* is the principal type of this study. Wallengren then critically compares the accounts of Stein, Möbius, Maupa, and Schuberg concerning *Euplotes charon*, *E. palella*, and *E. harpa*. All of the accounts are very incomplete and, like that of Wallengren himself, are confined to the external changes. Wallengren has made a very careful study of the formation of the new peristome and of the origin of the new cirri during the division of *Euplotes harpa*, and of the resorption of the old set of cirri which are replaced by the new ones formed. Further reference will be made to this article as my description of the processes occurring in *Euplotes worcesteri* progresses. Unfortunately, I was not able to secure the original article of Wallengren until after my paper was ready for the press; my observations upon the origin of the peristome were therefore entirely independent. Since reading Wallen-

¹ Contribution from the Biological Laboratory, Bureau of Science, Manila, P. I.

² Associate professor of zoölogy in the University of the Philippines.

gren's paper I have added nothing to my own except the necessary critical comparisons; the observations stand as originally made.

It is evident that processes of division must be much alike in all the species of the genus *Euplotes*, though such differences exist as to render a comparative study extremely interesting. In considering the process of division I have omitted all reference to the divisions of conjugation and to the construction and resorption of organs during that phase, because my study of conjugation in *Euplotes worcesteri*, so far very incomplete, has convinced me that these processes are quite different from the ones of ordinary division. It has proved easy to keep the strain alive in the laboratory for more than a year and a half, and to secure an abundance of material for study and preparation in every possible manner. The result has been not only to prove that the new peristome is actually formed by an invagination, but also to reveal other curious processes connected with division. After an intimate study of a protozoan like this, one can appreciate the full force and meaning of the statement that many of the protozoa are *not simple, but extremely complex animals*.

The process of division of *Euplotes worcesteri* includes two stages, one of preparation, the other that of actual division of the body and meganucleus. During each stage a definite series of changes occurs in nearly every organ of the body. The stage of preparation for division includes the reconstruction and concentration of the meganucleus, the invagination of the rudiment of the new peristome, the division of the micronucleus, and the appearance of the new cirri. That of division includes the constriction of the body and separation of its halves, the drawing of the new peristome to the surface of the body and into its final shape and position, completion of the new pharynx, division of the meganucleus, absorption of the old cirri, and the shifting of the new cirri from the places of their origins to their ultimate positions.

RECONSTRUCTION OF THE MEGANUCLEUS.

By this is meant that a progressive change occurs in which all the chromatin of the meganucleus is actually dissolved and then reconstructed. The first stage of this process is the appearance at each end of the cord-shaped meganucleus of a band in which there is a complete absence of the ordinary chromatin reticulum. It will be convenient to refer to these as the *reconstruction bands*. They pass rapidly from the ends of the nucleus toward the center, finally meeting, and then disappearing. (Plates IV, V, and VI, figures 1, 2, 3, 4, 8, 10, 13, 14, 18, 20.) Each band consists of two planes of about equal thickness, the one on the central side staining darkly and uniformly, while the other is not stained and consequently shows distinctly. No traces of a reticulum or of chromatin granules can be seen in the first plane; but the uniform stain which this region takes indicates that the chromatin has here been dissolved in the karyolymph; therefore, I call this the *solution plane*.

It appears to consist of a homogeneous fluid, no structure of any kind being visible; but it is probable that a linin network still exists there, masked by the stain.

I have given the name *reconstruction plane* to the clear distal plane. It follows the solution plane abruptly, without any noticeable transition region between the stained and clear zones. In many cases no structure whatever is visible with a magnification of 1,600 diameters in the central side of the reconstruction plane. On the distal side, fine fibrils of chromatin appear which are connected with the reticulum of the distal part of the nucleus. These increase in thickness and number very abruptly, making thus a quite definite distal limit to the plane. It is evident that, while reconstruction of the chromatin commences in the region I have termed the reconstruction plane, it is not limited to this, but proceeds most actively in the region just distal to it, where the chromatin fibers are so suddenly thickened. The anterior portion of the plane is in fact the region where solution has been completed and chromatin (in a stainable form) has entirely disappeared, while in the posterior part of the zone chromatin is appearing.

Although I have failed many times to see any structures in the central side of the reconstruction planes, on other occasions I have observed a reticulum of extremely fine, delicately staining fibrils occupying all parts of the plane. These seem to be true linin fibrils, for it is at their nodes that the granules of chromatin first appear, and the chromatin reticulum appears to be built upon them. I believe that the linin network, even though often invisible, is always present in all parts of the reconstruction band.

The staining power of the reconstructed chromatin is considerably greater than that of the portion not yet altered. In judging the depth of stain, care must be taken to allow for the concentration of the nucleus which follows soon after the reconstruction bands pass. However, it is true that in nuclei in which concentration seems not to have begun the new chromatin stains much more vividly than the old. It frequently forms numerous masses of quite large size at the nodes of the reticulum, although just as often the chromatin knots are not present.

The margin of the undissolved (central) reticulum is usually abrupt. It often appears as in Plate IV, figure 6, closed across the face of the solution plane. On the other hand, Plate V, figure 12, shows a nucleus in which the chromatin has evidently begun to dissolve a little distance in front of the dark solution plane.

The planes of solution and reconstruction are of nearly equal thickness, their combined thickness being about the same as the width of the nucleus.

The two reconstruction bands pass toward the center of the meganucleus at equal rates until they finally meet. (Plate V, figure 14; Plate VI, figures 18, 20.) The two solution planes then unite, and presently

disappear in the usual manner, leaving the reconstruction planes joined; the new chromatin reticula advance toward the center from both sides, unite, and leave no trace of the plane of junction.

A division of the chromatin substance by one, two, or three planes is not an uncommon character of the meganuclei of the Infusoria. Bütschli mentions the presence of "*Kernspalten*" in Euplotes, Aspidisca, Dysteria, Nassula, Strombidium, Spirochona, and Stylonychia, and in the families Chlamydomonta, Holophryina, Trachelina, and Tintinnoina. The reconstruction bands of Euplotes were long ago observed by Stein (1859), but they do not seem to have received any attention from other authors.

The clefts (*Kernspalten*) in the meganuclei of Stylonychia have been the classical examples of this kind of structure, all other similar appearances apparently having been interpreted as being the same. Judging from the account given by Bütschli, the *Kernspalten* of Stylonychia are structures entirely different from the reconstruction bands of Euplotes. They appear in the nuclei of Stylonychia shortly after division, disappearing as the next division begins, and usually lie a little in front of the middle of the anterior nucleus and behind the middle of the posterior one. If we agree that the two meganuclei of Stylonychia represent not separate bodies, but a stage of precocious division of a single meganucleus, the position of the "*Kernspalten*" reminds us of the appearance of the reconstruction bands of Euplotes first at the opposite ends of the nucleus. Beyond this, there is no apparent resemblance either in structure or history. I do not know of any work on the "*Kernspalten*" of other infusoria sufficiently detailed to permit a comparison to be drawn with the reconstruction bands of Euplotes.

Balbiani, in 1895, suggested that the unstained substance in the "*Kernspalten*" of Stylonychia may be composed of a mass of achromatic material, or archoplasm. No substantiation of this suggestion has yet appeared, nor do the observations of nuclear division in Stylonychia indicate that the "*Kernspalten*" exercise any directive influence upon the process.

Whether the reconstruction bands of Euplotes are of the same nature as the "*Kernspalten*" of Stylonychia or not, it is certain that they are not composed of archoplasmic substance, but are regions where a solution, change, and reconstruction of the chromatin occurs. The elimination of superfluous chromatin from the nucleus has been observed to occur in numerous Protozoa, and in some Metazoa. Many different means exist for the accomplishment of this object. In some cases granules of chromatin pass bodily through the nuclear membrane into the cytoplasm, where they may remain indefinitely and perform some useful function or may be rapidly altered into unrecognizable substances. In others, the useless chromatin is extruded from the chromosomes, but dissolved within the nucleus. Elimination regularly occurs before either division or conjugation, evidently as a part of the preparation for these processes.

Metcalf describes the formation of chromatin spherules from the chromosomes of *Opalina* in the course of each mitosis during the year, and suggests "that these chromatin spherules are nutritive—comparable to the granules of the macro-nucleus of higher ciliata. Their formation and extrusion (in *Opalina*) is positively useful, being probably connected with nutrition and perhaps with the formation of the refractive spherules of the endosarc."

The cases of chromatin elimination heretofore described do not compare closely with the process occurring in *Euplotes*, since in this form there is a complete solution of all the chromatin, and not of a part only. The rapid and complete disappearance of affinity for stains from the region affected indicates that the chemical nature of the chromatin is entirely changed. The possibility exists that a vegetative chromatin is removed by osmosis during the stage of solution and that then the most active chromatin reassumes its original condition. However, it seems much more probable that an interchange of materials between nucleus and cytoplasm takes place which is of such a nature that the reconstructed chromatin is essentially a new substance, not only relieved of the so-called vegetative chromatin, but rejuvenated throughout by a physical and chemical reconstitution. The more active condition of the chromatin after the completion of this process is shown by its increased staining power.

It would seem that during the ordinary life and activities of the cell, the chromatin either accumulates a certain amount of inert substance which can play no part in the activities of division, and which it would be useless, perhaps harmful, to carry over to the daughter cells; or else that a portion of the chromatin itself is so modified by its activities that it loses some of the properties essential to its sharing in division, and therefore is eliminated before or during that process. The latter view, which is merely an expression of the fact that destructive metabolism must occur in chromatin as in all other living substance appears most reasonable. It also seems quite probable that these products of chromatin metabolism may be so closely allied to the living substance of the cytoplasm as to be incorporated with it or, if considerably degenerated, to serve as food for the cell.

The reconstruction of chromatin by complete solution and reformation, such as occurs in *Euplotes*, is a process of a higher order, as regards its effect on the nucleus, than that of the elimination of chromatin spherules, as in *Opalina*. In the latter case, much of the chromatin remaining may have been in the nucleus for a considerable time and may be practically senescent; in the former case the possibility exists that the new chromatin may be entirely composed of new material derived from the cytoplasm. As the cytoplasm itself is a constantly changing substance owing to its various katabolic and anabolic activities, an interesting possibility that the new chromatin may be formed from materials only recently entering the body is instantly suggested.

There is a large field for research in the comparative morphology and physiology of the meganuclei of the Infusoria, and for a long time to come general conclusions can not safely be drawn regarding them, their activities, and relationships. However, these observations on the meganucleus of *Euplotes* indicate that the meganucleus is more of an active and less of a passive agent in the cell life than many zoölogists seem to believe. The very fact that the chromatin of the meganucleus is reconstructed in a manner which must include an elimination of passive (vegetative) chromatin, such as occurs in nuclei of the ordinary type, indicates that the meganucleus is not only an aggregation of such spherules of vegetative or nutritive chromatin, but includes in addition most other properties of the ordinary cell-nucleus.

The form of the nucleus is not altered during the first half of the period of chromatin reconstruction, but as the reconstruction bands approach the center of the nucleus the phase of concentration so universal in meganuclei of this shape is entered upon. Both ends become shorter and thicker, at the same time losing any small irregularities of contour. The more nearly the reconstruction bands approach each other, the more marked becomes the shortening of the limbs of the nucleus. The central portion, that is, the part lying between the reconstruction bands, is not usually affected. Figures 14 (Plate V) and 18 (Plate VI) show that this region has increased in thickness, which is not the case in figures 8, 10, and 13 (Plate V). As the ends of the nucleus become shorter and thicker, the threads of chromatin are also changed in the same manner, so that the chromatin becomes condensed. Chromatin condensation always follows, never precedes, the reconstruction phase. Therefore, the center of a nucleus in which the reconstruction planes are close to each other often presents a marked contrast to the greatly concentrated ends. Unless the stain is carefully extracted the condensed portions of a nucleus appear uniformly stained, as if the chromatin network had been welded into a homogeneous mass. It is certain that the reticulum does not disappear at any stage, even that of greatest concentration, but in the last stages it is often impossible to distinguish the threads. Figure 22 (Plate VI) shows the appearance of a poorly extracted nucleus in the concentration phase, in which a reticulum is visible in only two places. After the reconstruction of the chromatin is complete, the concentration proceeds very rapidly, until the nucleus becomes a short, thick rod, varying somewhat in form, which lies in the region formerly occupied by the center of the horseshoe-shaped nucleus. The process of concentration is evidently one of contraction of both ends of the nucleus toward the center, for the latter portion of the nucleus does not move from its place.

"Bei dieser *Concentrirung* gegliederter Kerne muss die Membran wohl eine wesentliche Rolle spielen, da wir wissen, dass die Verbindungsfädchen häufig nur von ihr gebildet zu sein scheinen." (Bütschli, *Protozoa*, p. 1524.)

I do not feel that at the present time anything of value regarding the origin and purpose of the process of concentration can be added by me to the explanation Bütschli has already advanced. (*Lot. cit.*, p. 1524.)

“Eine Erklärung für die Concentrirung des Makronucleus zu geben, scheint einstweilen kaum möglich. Active Contractionserscheinungen im gewöhnlichen Sinne dürften dabei schwerlich mitwirken. Man könnte eventuell an eine sehr einfache Deutung denken, welche jedoch etwas gewagt erscheint. Jedenfalls müssen im ruhenden Zustand besondere Einflüsse auf den band- bis rosenkranzförmigen Nucleus wirken, welche ihm die eigenthümliche Gestalt verleihen. Das einfachste, was man sich in dieser Hinsicht denken könnte, wären äussere Zugkräfte, welche ihn dehnten und zunächst bandförmig und schliesslich rosenkranzförmig werden liessen; nach Analogie mit einem zähen Flüssigkeitsfaden, welcher sich bei genügender Streckung ebenfalls perlschnurförmig gliedert. Solche Einwirkungen auf den Makronucleus könnten nur vom umgebenden Plasma ausgehen, und die Frage wäre, ob sich hierfür Anzeichen finden liessen, etwa analog den bei *Isotricha* beobachteten Karyophoren. Wenn nun diese Einflüsse bei Beginn der Theilung aufhörten, so würde der Nucleus von selbst wieder zu seiner natürlichen Gestalt, d. h. der kugligen bis nahezu kugligen zurückkehren.— Etwas gegründeter sind unsere Vorstellungen von der Bedeutung des Vorgangs. Wir erblicken darin, im Anschlusse an die Roux'schen Ideen, eine Erscheinung, welche eine möglichst gleichmässige Halbierung des Nucleus inhalts, der in den langen Kernen ziemlich ungleichmässig vertheilt sein kann, bei der Theilung ermöglicht.”

The period of greatest condensation is reached at a time when the body is ready to commence the process of transverse fission. The nucleus does not remain in this condition for more than a few minutes. It then elongates rapidly, forming a thick, somewhat bent rod, extending through nearly the entire length of the body. As the nucleus elongates, its reticulum of chromatin becomes more easily visible, although the condensation is still great enough to make the nucleus appear dark and solid. Possibly the chromatin may also be stained more intensely at this stage than later. As the nucleus elongates, both the anterior and posterior ends curve toward the left. (Plate VII, figure 26.) These curves increase as the constriction of the body deepens, while the middle portion of the nucleus connecting them remains straight and occupies the isthmus connecting the separating halves of the body. (Plate VII, figure 27.) As fission proceeds to the stage when the daughter animals remain connected only by a narrow neck of protoplasm (Plate VII, figure 28), the upper and lower halves of the meganucleus increase in length and also in curvature, while the straight middle portion becomes reduced to an extremely tenuous thread, which presently breaks (Plate VII, figure 29). While the nucleus is elongating, bending, and dividing, the reticulum becomes more and more plain. This is partly because the chromatin fibers become thinner and partly because of their lessened affinity for stains, rendering extraction of the stain more perfect. A noticeable feature of the reticulum at this time is the great longitudinal elongation of its meshes. This appearance of the network and the manner in which

the meganucleus is pulled out into a thread at the point of division appear to be expressions of the internal tensions existing during this period, and, to a certain extent at least, are evidence supporting the theory of Bütschli quoted above, that the elongated shape of the nucleus is the result of and is maintained by cell-tensions. The contractility of the nuclear membrane and of the intranuclear reticulum are factors which seem sufficient to account for the concentration of the meganucleus, but they can not cause its elongation. During the process of concentration the karyolymph has been almost completely expelled from the nucleus. Absorption of karyolymph during expansion increases the volume of the meganucleus, but can not of itself direct expansion in particular directions. This must be accomplished by tractive force exerted upon the nucleus by the cytoplasm, of which we have visible evidence in the temporary stretching of the reticular mesh. Figures 30 and 31, Plate VII, are drawings of *Euplotes* immediately after fission. In figure 31, the anterior end of the nucleus still remains drawn out into a point which ends just inside the pellicle. This point, as well as other irregularities of the anterior end of the nucleus, would have been lost very quickly, for the nucleus grows into its ordinary form soon after division.

DIVISION OF THE MICRONUCLEUS.

The micronucleus divides much more quickly than the meganucleus, commencing after the reconstruction phase of the latter has started, and being completed some time before that phase has ended. The chromatin of the resting micronucleus exists in the form of a reticulum, which is only visible after thorough extraction of the stain. (Plate IV, figures 1, 2, and 3.) Soon after reconstruction of the meganucleus has been entered upon, the micronucleus increases in size to about double its ordinary dimensions. The enlargement appears to be due to an increase in the fluid contents, for no change in the chromatin can be seen.

Rearrangement of the chromatin commences when the reconstruction bands of the meganucleus have proceeded about one-quarter of their distance. The chromatin meshes first become elongated in the direction of the anterior and posterior poles of the micronucleus; next they may be found as threads reaching from end to end of the nucleus with a slightly spiral twist. (Plate V, figure 10.) It is evident that the chromatin threads are increasing in thickness and staining power. At the same time the micronucleus swells still more. The spindle is formed by the elongation of these threads of chromatin which stretch from pole to pole. (Plate IV, figure 5.) I have not been able to distinguish purely linin fibers at any stage of the ordinary division mitosis, for all spindle fibers appear to contain chromatin. Appearances in the mitosis of conjugation lead me to believe that during ordinary mitoses the linin fibrils are completely covered by or otherwise inseparably joined to the chromatin.

It is difficult to determine the number of chromosomes accurately, in spite of their small number. The usual number appears to be six or seven, although I have counted eight on a few occasions; but at other times I have been able to distinguish only four, or five. When the spindle is first fully formed the chromosomes are thickest at their middles, tapering slightly toward the ends. As division progresses the chromatin passes away from the middle of the chromosome toward the end, until finally the central portion is reduced to an extremely fine fibril connecting the considerably enlarged ends. (Plate VI, figure 19.) This still stains with chromatin stains, so does not seem to correspond exactly to the ordinary linin fibril. After the chromatin has become massed at the poles, the spindle elongates very considerably, the fibrils still joining pole to pole.

It will be seen by a comparison of figures 8, 10, 13, and 14, Plate V, that metaphase and anaphase occur with great rapidity, since there is almost no difference in the condition of the meganuclei of figures 8, 10, and 13. Stages of the micronucleus like those shown in figures 13, Plate V, and 21, Plate VI, are also extremely rare. These are the only anaphase and telophase stages I have been able to find in an examination of many hundreds of dividing individuals. The shape of each daughter micronucleus in figure 13, Plate V, shows plainly that the final step in division is a rapid separation of the poles of the spindle, while the spindle fibers remain unbroken for a considerable time. A break finally occurs at the center of the spindle and the fibers of each half of the spindle are withdrawn into their respective nuclei. A clear space is found around the micronucleus in nearly every preparation of dividing *Euplotes*. I can not consider this as anything but an artifact, caused by slight shrinkage of the distended and fluid-filled micronucleus.

The daughter micronuclei separate rapidly after division, quickly coming to rest at the points which will be their permanent positions in the daughter bodies. These positions are retained throughout the further processes of division.

The micronuclei rapidly assume the ordinary resting structure, and to all appearances are perfectly passive during the succeeding, most active phases of division. The short-lived activity of the micronucleus and its succeeding passivity are in marked contrast to the activities of the meganucleus and of the body as a whole. The meganucleus, supposedly a vegetative organ, exhibits far more constructive and directive activity than the micronucleus, which is usually considered to be the principal directive agent in division. The formation of chromosomes and their division in the micronucleus is a simple matter compared with the complex physical and chemical changes occurring in the chromatin of the meganucleus. The activities of the meganucleus begin with or before the first intimation of other division processes, and continue until after

fission is complete, and ordinary, normal growth is entered upon. In contrast to this the micronucleus is active during only a very short period of the division. Therefore, if a conclusion were to be drawn from the behavior of the nuclei of *Euplotes*, it would be that the meganucleus is not only the controlling organ in the metabolic activities of the ordinary life of the animal, but it is also the active and directive agent of ordinary (or vegetative) division, so far as any one portion of the cell can be considered independently of the others; while the micronucleus is more passive than directive, its part in division being limited to dividing in such a way as to supply each daughter cell with a micronucleus. This division appears to be more of an incidental feature of fission than one of the causative forces.

DEVELOPMENT OF THE NEW PERISTOME.

The rudiment of the new peristome appears simultaneously with or shortly after the beginning of the reconstruction of the meganucleus (Plate VI, figures 1 and 3), and in the form of a small, somewhat elongated depression just back of the posterior margin of the old peristome. The medial wall of the depression is nearly vertical, while the lateral wall curves gently and evenly. The rudiments of a row of membranellæ can be seen on the lateral wall in the earliest stages. These first stages of peristome formation in *E. worcesteri* are quite different from the corresponding ones of *E. harpa* as described by Wallengren. In that form a triangular area of the ectosarc back of the old peristome becomes clearer than the surrounding regions, and is definitely limited between the posterior margin of the old peristome, the left-hand ventral ridge, and a new temporary elevation. The invagination of the rudiment of the new peristome occurs at the anterior end of this field, very close to the border of the old peristome. Neither the clear ectosarc field, nor the external delimiting ridge appear in *Euplotes worcesteri*, nor does the rudiment of the new peristome lie so close to the border of the old peristome in that species as in *E. harpa*. The extremely difficult matter of finding early stages of the peristome formation in *E. worcesteri* would have been rendered far easier if such a change in the ectosarc had taken place.

I have also found that the rudiments of the adoral membranellæ appear considerably sooner in *E. worcesteri* than in *E. harpa*. The further development of the new peristome to its full extent is nearly the same in both species. The depression deepens and extends posteriorly, not upon the surface but *beneath* the ectosarc, forming a short narrow invagination. The mouth of the original depression becomes the opening of the invagination, retaining for a time about the same size and shape as first. The invagination now rapidly extends anteriorly until it nearly reaches the micronucleus. I have seen the invagination pass-

ing the micronucleus in only a few instances. The invagination extends a little farther forward in *E. worcesteri* than in *E. harpa*. At the same time it pushes a little backward and mediad and also increases considerably in width and depth. Before the invagination has attained its full length the opening to the exterior usually becomes elongated, its edges approach and finally fuse, and the new peristome exists for a time as a completely closed cavity inside the body of the Euplotes. The ventral wall of the new peristome now lies \pm or 5μ dorsad to the old peristome.

The position of the new peristome is shown very clearly by sections. Figure 7, Plate IV, is a drawing of a transverse section of an animal in about the same stage as figure 4. The section passes just in front of the tip of the pharynx. The new peristome (P) lies below the old adoral membranellæ; inside of it the membranellæ of the new adoral zone are already well developed; as Wallengren also has observed, they move actively inside the new peristome almost from the first. Figure 16 (Plate V) was drawn from a longitudinal vertical section of a stage similar to figure 10. It passes through the old adoral zone (az) parallel to the axis of the body. Below this lies the new peristome which reaches the surface at O, where the lips of the external opening are still in contact. The membranellæ of the new adoral zone (AZ) lie outside of part of the section; at the posterior end of the cavity the membranellæ which there lie upon the outer wall are shown in transverse section. The individual cilia of the adoral membranellæ are particularly noticeable in a section like this. After remaining closed for a time the external aperture of the new peristome reopens and rapidly increases in size. (Plate V, figures 10, 13, 14; Plate VI, figures 18, 20, 22, 25; Plate VIII, figures 33, 34, 35.)

The figures show that the time at which the final opening occurs varies somewhat, using the condition of the meganucleus as a standard for comparison, and so does the rate at which the enlargement of the aperture increases. Wallengren did not observe any closure of the peristomial aperture in *Euplotes harpa*.

After the new peristome has become permanently opened, the posterior end of the cavity increases considerably in length and also bends toward the center of the body. The portion of the posterior end of the invagination which will become the pharynx is shown by Plate V, figure 10, where the rudiment of the suboral group of membranellæ (S O) lies in a slight expansion of the cavity. Since the suboral membranellæ of the adult Euplotes lie just within the mouth, it is clear that the invagination includes the rudiment of the pharynx as well as that of the peristome, and that the pharynx is formed some distance from its final position. The same peculiar bulging of the medial wall of the invagination is shown in Plate V, figure 13, although the suboral membranellæ were not visible in this specimen.

As figures 10 and 13, Plate V, were among the last drawings made, it is almost certain that the slight enlargement of the pharynx was present in other specimens (Plate V, figure 14; Plate VI, figures 18, 20, 22, 25; Plate VIII, figure 33) but not noticed at the time the sketches were made,

as its importance then was not appreciated. Plate V, figure 17, and Plate VI, figure 24, are both drawings of sections passing through the aperture of the peristomial invagination.

The further development of the peristome and pharynx proceeds as the body divides. The body of the *Euplotes* elongates a little before any constriction appears. This change in shape is made evident by the new peristome moving backward, as if it were pulled out from beneath the old one. (Plate VIII, figures 33 and 34.) By the time that the constriction of the body can be noticed, the opening of the new peristome to the exterior has become large, extending from the posterior margin of the old peristome to the posterior end of the new one. (Plate VIII, figure 34.) At the same time the anterior end of the peristomial invagination bends toward the middle of the body. Plate VIII, figures 34, 35, and 36 are successive drawings of one individual, made at intervals of about half an hour; they illustrate the manner in which constriction of the body, further increase in the size of the opening of the new peristome, and bending of the anterior end of the new peristome toward the right, proceed simultaneously. In *Euplotes harpa* the curvature of the anterior end of the new peristome toward the right commences at a very early stage, even before the invagination has attained its full length, and long before constriction of the body begins. There is also in that species an inward bending near the middle of the new peristome which is altogether lacking in *E. worcesteri*. The anterior end of the adoral zone lies in a cavity derived from the original invagination (Plate VII, figure 27, and Plate VIII, figure 36) until fission is nearly complete. As the constriction of the body deepens, the adoral zone is more and more uncovered, reaching the adult condition while the two bodies are still connected. (Plate VII, figures 28 and 29.)

While the anterior end of the peristome is passing across the end of the body, the pharynx moves still more toward the center of the body and its tip bends forward. (Plates VII and VIII, figures 26, 28, 34, 35, 36.) The widening in which the suboral membranellæ appear develops into the anterior expansion of the pharynx, in which the rows of endoral cilia appear before the constriction of the body is far advanced. (Plate VII, figure 26.)

The medial margin of the peristome is not derived from the inner edge of the growing aperture of the invagination, but from a ridge which grows forward from the anterior angle of the mouth across the medial wall of the peristomial depression. Plate VII, figure 26, Plate VIII, figures 34, 35, and 36, show successive stages in the development of this feature. As in *Euplotes harpa*, this ridge divides the right wall of the peristomial cavity into two portions; the dorsal portion becomes the inner wall of the completed peristome, while the ventral moiety becomes included in the ventral surface of the body. The part of the ventral covering of

the peristomial cavity extending out from this moiety becomes reabsorbed and leaves no ridge to mark its original relations, as in *E. harpa*. At the stage shown in figure 36, the inner margin of the peristome which has been formed in the manner just described, has united with the inner wall of the anterior portion of the peristomial invagination which still remains. By the deepening constriction of the body the outer wall of this cavity is carried away, and the medial wall becomes the margin of this side of the completed peristome. The relation of the inner edge of the aperture of the invagination to the medial margin of the completed peristome can clearly be seen by examining the cirrus marked *f* in figures 33 to 36, Plate VIII. It lies inside the original aperture, but outside of, i. e., medial to, the true margin of the peristome.

I have carefully considered if the new peristome results from an outgrowth of the old one, and if the invagination could be formed from a linear depression of the edge of the old adoral zone, or of the region immediately lateral to that zone. There is no evidence that either of these processes occur. Instead, I have been able to follow the process of invagination, as above described, many times in living animals, and also in mounted and sectioned material. The sections leave no trace of doubt regarding the internal position of the new peristome. In the transparent living animals the adoral membranellæ of the peristomial invagination lie at a slight angle to those of the old adoral zone, and since they are all in rapid motion, the relative positions of the two zones can be determined indubitably.

The formation of the new peristome and pharynx by invagination may be a process developed in order that these parts shall be fully formed when fission commences, and to insure that the posterior daughter animal may be able to take up independent normal existence after fission without any delay. It will be noticed that all new structures, of whatever kind, are functionally complete in this animal by the time that fission is accomplished. The peristome extends so far toward the posterior end of an adult animal that a complete peristome can not be formed upon the surface of the body back of this point, while there is also little room between the left edge of the body and the margin of the peristome for such development. It should be noted that fission in this form is not merely a pinching in two of the body, but a process by which material is withdrawn from the anterior half of the body, which results in the formation of two daughter bodies very different in form from a half of the mother body at the time fission began. Therefore, the invagination of the peristome seems to be an anticipatory process related to the development of the new body and cirri.

There can be no question of overgrowth in the formation of this invagination, as in the more familiar examples of invagination among metazoan embryos. The direction of growth here is evidently controlled by internal tensions either of ectosarc or endosarc.

A process of this kind also suggests that a certain functional independence of ectosarc and endosarc exists in spite of close structural relations. The very definite and regular structure of the ectosarc has been spoken of in the first part of this paper; the process of invagination (in which the ectosarc chiefly is concerned) suggests that the relations of the primary germ layers of Metazoa may be quite *definitely* foreshadowed in some of the higher Protozoa.

Development of the new cirri (Plates VI, VII, and VIII, figures 25, 32, 33, 34, 35, and 36).—While the changes described in the foregoing pages have been proceeding, a new complement of cirri is developed for each half of the mother body, and all of the original cirri are absorbed. The order in which these events occur is decidedly definite. In order to follow the course of the new cirri we must distinguish each of the cirri of the fully formed body. The frontal cirri I have numbered in figure 32, Plate VII, from 1 to 7; the ones usually called abdominal cirri are numbered 8, 9 and 10; the anal cirri are I to V; the left marginal cirri are L1 and L2, while the right marginal cirri are R1, R2, and R3.

At about the time that the meganucleus reaches the condition of greatest condensation, ten slit-like, longitudinal depressions appear in two rows of five each upon the ventral surface of the body. The two complete rows appear simultaneously, and not successively, as Wallengren observed in *Euplotes harpa*.

The slits of the anterior row I have distinguished by the letters A, B, C, D, and E; those of the posterior row by *a*, *b*, *c*, *d*, and *e*. By combining these letters with the numbers of individual cirri, each cirrus, its origin, and its course can be indicated.

The slits are produced both by the solution of the pellicle and by depressions of the ectosarc at those points. The places where the slits appear are very definite and subject to little variation, being always practically the same as shown in Plate VII, figure 32. In this specimen cirrus 7 occupied a position a little back of its usual one. It generally stands to the right of the anterior end of slit A. (See Plate VI, figure 25.) It will be noticed that cirrus 9 stands between the posterior ends of slits C and D, and also that slit E is widely separated from D, and, unlike the others of this row, points toward the edge instead of the center of the body. It also is important to observe that slits *a* to *e* arise outside of the depressions of the adult anal cirri.

There is almost no difference between *Euplotes worcesteri* and *E. harpa* in the points at which these slits appear. The only considerable difference in the origin of any of the cirri is in the case of the cirrus named F by me, and I-1 by Wallengren. This cirrus arises much farther forward in *E. harpa* than in *E. worcesteri*; the arrangement in *E. harpa* is such that there is much less difference in the origin of I-1 of the two daughter bodies than in *E. worcesteri* between cirri F and *f*.

The bottom of each slit becomes elevated in the form of a thin irregular ridge which is the rudiment of the cirri which presently appear in the depression. The ridge does not have the character of an undulating membrane (as described by Stein and Sterki for *Stylonychia*), but the shape of the depression apparently controls the form of the elevation of protoplasm from its floor. The edge presents points which seem to be the first indications of the cirri to be formed in a few moments, since in the few instances which I have been able to observe the number of points on the ridge coincided with the number of cirri to arise from that particular depression. Wallengren finds that each cirrus of *E. harpa* arises independently of the others in the same slit, and that there is no indication of an undulating membrane, or a protoplasmic ridge such as I describe, preceding the appearance of the cirri. He also observes the posterior cirrus of each group to appear first, followed in succession by the more anterior ones. So far as I have been able to observe, all the cirri of a group arise at the same time in *E. worcesteri*, although it is true that the posterior one of each group outstrips its fellows in growth from the very first.

The early development of the cirri must proceed very rapidly, for the stage in which the depressions only exist is very rarely seen among large numbers of dividing individuals. Specimens like figures 25 or 33, Plates VI and VIII, are common enough.

Three cirri arise in each depression, except in the one at the left of each row where but two appear. From the fourteen cirri thus appearing in each row are formed all the frontal, abdominal, and anal cirri of each daughter body, except one. The history of this last cirrus is peculiar, and is different in the two bodies. That of the anterior body (F) appears to the left of slit A, just behind cirrus 7, usually as is shown by figure 25, Plate VI. The corresponding cirrus of the posterior body (f) springs from the medial wall of the peristomial invagination, just within the aperture and immediately after its permanent opening. Neither of these cirri arises from a depression like the others.

The left marginal cirri of the two bodies also arise from depressions to the right of the old and new peristomes. (L M, *l m*, figures 32, 25, and 33.) The development of the left marginal cirri resembles that of the ventral cirri.

As the cirri of groups A, B, C, D, E, *a*, *b*, *c*, *d*, and *e* grow, the depressions in which they arise also increase, particularly in length. (Plate VI, figure 25, and Plate VIII, figure 33.) The enlargement of the grooves *a*, *b*, *c*, and *d* causes the effacement of the anterior portions of the original grooves of the anal cirri I to IV, while the portions left, in which the anal cirri still stand, are directly behind the new grooves, separated from them only by narrow oblique ridges. (Plate VIII, figure 33.) The remnants of the old grooves are effaced very soon after this stage.

In the elongation of the groups of new cirri, the posterior one of each group remains at the point where it appeared while the anterior ones are shifted forward. In the case of the triple groups, the two anterior cirri remain close together and one behind the other until the rearrangement is nearly completed. As the new cirri approach the anterior limits of each daughter body, the anterior portions of the depressions become separated from the posterior, or open upon one side (Plate VIII, figures 34 and 35), and then gradually are obliterated. A curious feature of this process is that the left margin of the depression seems always to be the first to disappear. The portions of the grooves remaining about the posterior cirri now assume the form and position characteristic of the adult Euploes. (Plate I, figure 1.) The anterior cirrus of group E is the first to become independent of its mate. The two of group D next lose their alignment, and separate. Those of group C follow, while the anterior pairs of B and A retain nearly the original relations until the development of the daughter bodies lacks little of being complete.

While the new cirri are developing the old ones are being absorbed, one by one. The absorption begins as soon as the new cirri appear. The first to go seems to be anal I (Plate VIII, figure 33), although 8 and 9 may disappear at the same time. Anal II follows next (Plate VI, figure 25), and then anal V (Plate VIII, figures 34 and 36); 8 and 9 are sure to be gone by this time, and usually several of the frontal cirri, as is shown by figure 34, Plate VIII, where 4, 5, 6, and 7 have disappeared. At the time this specimen had reached the stage shown by figure 36, cirri 1 and 10 and one of the right marginals had also gone. After this it is only a matter of minutes before the remainder of the old cirri, frontals, anals, and marginals, disappear, so that by the time division is completed not one of the old cirri of the mother body remains.

The final disposition of the new cirri can be followed better from Plate VIII, figures 33 and 36, than from any description. The most peculiar thing in the course of this development is the manner in which the new frontal cirrus 4 of each body develops. This is quite different in the two bodies, yet essentially similar. The single cirrus F which develops just back of frontal 7 has been mentioned. This increases in size at the same rate as the outer new cirri, and without much change of position becomes the new frontal 4 of the anterior daughter body.

The corresponding cirrus in the posterior daughter body springs from the inner side of the peristomial aperture as soon as this reopens. (Plate VI, figures 23 and 25.) It is extremely active in its movements from the first, waving with a spiral motion so rapid and continued as to suggest that it is actively engaged in directing food into the new peristome. That this is not the case is proven by the complete absence of food balls from the peristomial invagination. For a long time this motile organ, apparently a part of the buccal apparatus, proved very puzzling. But,

as has been mentioned, it was finally observed that after the peristomial aperture has grown to a large size a ridge arises, beginning at the anterior angle of the mouth, and passing forward lateral to the cirrus just described. (Plate VIII, figures 34 and 35.) This ridge becomes the medial wall of the completed peristome, while the original medial margin of the peristomial aperture and part of the medial wall of the cavity become included in the ventral surface of the body. (Plates VII and VIII, figures 26, 34, 35, 36.) In this manner the cirrus arising in the peristomial cavity also becomes shifted to the ventral surface, and lies not far from its final position of frontal cirrus 4. (See *f* and *f* 4.)

The development of the left marginal cirri presents no noteworthy features. These cirri have reached their final positions and proportions by the time the bodies separate. Right marginals are formed upon the margins of both daughter bodies before final separation takes place, but were not observed in any of the specimens drawn.

The final disposition of the cirri is exactly the same in *Euplotes worcesteri* as in *E. harpa*. While the figures of Minkiewicz of *E. vannus* are very incomplete, the process is evidently the same in that species.

Sensory bristles.—At an early stage in the development of the cirri, numerous additional groups of granules appear upon the ventral surface. Their positions bear an evident relation to the new cirri. As each group of granules of the adult *Euplotes* surrounds the base of a sensory bristle, the same relation must be true of the new granules, although the direct observation of the bristles at this stage is practically impossible. I have not been able to decide whether the old sensory bristles all disappear and are replaced by new ones, or whether new bristles appear only in those portions of the two new bodies which otherwise would be left without any by the division.

The sensory bristles of the dorsal surface and their related groups of granules do not show any changes before division. New bristles apparently are interpolated in the dorsal rows during the period of growth which succeeds fission.

It has been known for many years that the old peristome, which is retained by the anterior daughter body, is not always retained without change. Confining ourselves to the genus *Euplotes* the only author who has mentioned in detail these changes in the old peristome is Wallengren. He finds that the mouth of *Euplotes harpa* atrophies so that neither food nor water is taken in during the later stages of fission. Neither his figures nor his description throw any more light upon this point. He also observed that just before division takes place the lower lip becomes filled with a great number of round granules. He did not observe any other changes in the form or structure of the peristome, nor any reconstruction of the adoral zone. I have been unable to observe any changes whatever in the old peristome of *E. worcesteri* during division. The

mouth and pharynx remain open, the pharyngeal membranelæ being ordinarily active; the edges of the peristome remain as sharp as ever, and there are no signs of destruction of the adoral membranelæ. I am convinced that the old peristome continues unchanged in the anterior daughter body.

The suggestion made by Wallengren that the reason for the complicated development of new cirri and absorption of old ones among Hypotricha lies in the fact that the mother organs are not adapted to the needs of the daughter cells either in size or position, seems to me not entirely sufficient. It is often found that the new anal cirri of the posterior daughter body before division are not to be distinguished from the remaining old ones except by position. The same holds true occasionally for the frontal cirri. Division takes place in such manner that the explanation suggested by Wallengren must be true of part of the cirri. It does not appear to account sufficiently for the replacement and absorption of the cirri which are so placed that division does not seriously affect their position or action. However, in *Euplotes harpa* the shape of the body and the manner in which division occurs are such as to give color to Wallengren's suggestion.

DIVISION OF THE BODY.

Constriction of the body does not appear until the new cirri are all present (except the right marginals) and have moved nearly to their final positions (Plate VIII, figure 34); until the new peristome is widely open and has been drawn backward a considerable distance by the elongation of the body (note the difference in the distance from the anterior to the posterior pharynx in figures 25 and 34, Plates VI and VIII); until after the micronucleus has divided and the two daughter micronuclei have moved apart to their final positions, and the meganucleus has passed from the stage of concentration to that of elongation (Plate VI, figure 25, and Plate VII, figure 26). The constriction deepens rapidly, and separates the bodies in from one to two hours. An animal which is preparing for division is almost always considerably broader and more ovoid in outline than a "resting" individual. (Compare figures 1, 3, 25, and others, with 28 and 29, where the bodies have attained an almost typical shape before division is completed.) Even before constriction commences the body begins to grow longer and narrower. (Plate VIII, figure 33.) This change is caused by the backward growth of the region back of the old mouth, which will become the posterior individual. The movement is not simply an elongation or even an increase in mass of the posterior part of the body, but is brought about by the withdrawal of some material from the anterior portion of the body. That this must be so is proved by the backward movement of the invagination of the new peristome, which is pulled out from over the old peristome (Plate VIII, figures 33, 34, 35, Plate VII, figure 26) and by the fact that

the anterior half of the body becomes narrower at the same time. As the new peristome moves backward its anterior end is bent to the right; the fact that the inclination toward the right is greater at first than the amount of constriction of the body, indicates that pressure exerted by the latter process is not the sole cause of the bending, but that internal directive forces (or tensions) of considerable strength exist. This is still more clearly shown by *Euplotes harpa*, in which the peristome is bent to a right angle before constriction begins. The further bending and extension of the peristome across the anterior end of the new body proceeds at the same rate as the constriction, and appears to be produced by it. It is impossible to say certainly whether new adoral membranellæ are formed as the zone extends across the front of the body or not, but it seems more probable that all the membranellæ are formed in the invaginated peristomial cavity before this movement commences, and that increase in the length of the zone is secured by intercalary growth only. The basis for this supposition is that the number of membranellæ in the invagination (Plate VII, figure 32, Plate VIII, figure 33) is equal to the entire number generally found in the adoral zone and pharynx of an adult *Euplotes*.

The extension of the adoral zone toward the right forces the connection between the bodies to remain at that side. (Plate VII, figures 28, 29.) As the constriction is carried across the body, the thin ventral wall of the remaining part of the peristomial cavity (Plate VIII, figure 36) is broken through; a portion remaining may form the marginal lamella of the medial wall of the completed peristome. (Plate VII, figures 28 and 29.)

The stalk connecting the daughter bodies is sometimes drawn out into a slender thread of some length; it is not unusual to see a pair of individuals swimming rapidly about connected in this manner, the posterior one swinging from side to side as if the two were engaged in a game of crack-the-whip. By the time that separation occurs the two bodies may have their usual form, or they may be of such shapes that the observer can very easily be certain which was anterior and which posterior before division. (Plate VII, figures 30 and 31.) A new contractile vacuole appears in the anterior body before fission is complete.

LITERATURE.

- BALBIANI, G. Recherches sur les phénomènes sexuels des Infusoires. *Journ. de la Physiol.* T. N. Paris (1861), 102-130, 174-220, 431-438, 465-520; pl. 7-9.
- IDEM. Sur la structure et la division du noyau chez le *Spirochona gemmipara*. *Ann. de Microgr.* (1895), 7, 289.
- BÜTSCHLI, O. Studien ii. d. ersten Entwicklungsvorgänge d. Eizelle, d. Zelltheilung, und die Conjugation der Infusorien. *Frankf. Abhandl. d. Senckenb. Gesells. Naturf. Freunde* (1876), 10, 213-452; 15 pl.
- IDEM. Protozoa. Bronn's Klassen und Ordnungen des Thier-Reichs. (1887-89), 1, Abt. III. Infusoria.

- CALKINS, G. N. The Protozoa. Columbia University Biological Series, 6. New York (1901).
- IDEM. Marine Protozoa from Woods Hole. *Bull. U. S. Fish. Com.* (1902), 21, 415-468; 69 text-figs.
- CARTER, H. J. On Plesconia and Kerona. *Ann. & Mag. Nat. Hist.* (1859), 241-258; 1 pl.
- CLAPERÈDE, E., et LACHMANN, J. Études sur les infusoires et les rhizopodes. *Mém. instit. Gênévoise* (1858), 5, 260, 13 pl.; (1859), 6, 261-482, 11 pl.; (1861), 7, 291, 13 pl.
- DUJARDIN, F. Histoire naturelle des zoöphytes infusoires, comprenant la physiologie et la classification de ces animaux, etc. Paris (1841).
- ENGELMANN, T. W. Zur Naturgeschichte der Infusionsthier, *Ztschr. wiss. Zool.*, (1862), 347-393, pl. 28-31. A full abstract by Dr. Arlidge appeared in *Ann. & Mag. Nat. Hist.* (1862), 241-261, 1 pl.
- IDEM. Ueber Entwicklung und Fortpflanzung der Infusorien. *Morph. Jahrb.* (1876), 1, 573-635, pl. 21 and 22. (Appeared in 1875 in *Onderzoek. ged. i. h. physiol. Labor. d. Etrecht Hoogeschool*. 3. Reeks.)
- MAUPAS, E. Contribution a l'étude morphologique et anatomique des infusoires ciliés. *Arch. Zool. Exper.* (1883) (2), 1, 427-664, pl. 19-24.
- IDEM. Sur la conjugaison des infusoires ciliés. *Compt. rend. Acad. sci. Paris* (1886), 102, 1569-1572.
- METCALF, M. M. Opalina, its anatomy and reproduction, with a description of infection experiments and a chronological review of the literature. *Arch. f. Prot.* (1909), 13, 195-375; 15 pl., 17 text-figs.
- MINKIEWICZ, R. Studies on the Protozoa of the Black Sea. I. The organization, multiplication, and systematic position of the genus Euplotes Ehrbg. (In Russian, with a résumé in French.) *Tradui Kazan Univ.* (1901), 35, 67, 2 pl.
- MÖBIUS, K. Ueber die Theilung des Euplotes harpa. *Sitzungsber. d. Ges. natfor. Freunde z. Berlin* (1887), 102-103.
- IDEM. Bruchstücke einer Infusorienfauna der Kieler Bucht. *Arch. Naturg.* (1888), 54, 81-116, 4 pl.
- PROWAZWK, S. Protozoen Studien, III, Euplotes harpa. *Arb. Inst. Wien.* (1902), 14, 81-88, 1 pl.
- REES, J. VAN. Zur Kenntniss der Bewimperung der hypotrichen Infusorien, etc. Amsterdam (1881), 1 pl.
- ROSSBACH, M. J. Die rhythmischen Bewegerscheinungen der einfachsten Organismen und ihr Verhalten gegen physikalische Agentien und Arzneimittel. *Verh. d. physik-med. Gesellsch. Würzburg.* (1872), N. F., 2, 179-242, 2 pl.
- SCHAEFFER, A. A. Selection of food in Stentor cœruleus (Ehr.). *Journ. Exp. Zool.* (1910), 8, 75-132, 2 figs.
- SCHUBERG. Zur Kenntniss des Theilungsvorgangs bei Euplotes patella Ehrbg., *Verh. naturh.-med. Ver. Heidelberg* (1900), (N. F.), 6.
- STEIN, FR. Der Organismus der Infusionsthier, Leipzig (1859-1883).
- STERKI, V. Beiträge zur Morphologie der Oxytrichinen. *Ztschr. wiss. Zool.* (1878), 31, 29-58, pl. 4.
- STOKES, A. Some New Infusoria. *Amer. Nat.* (1885), 19, 433-443.
- WALLENGREN, H. Studier öfver Ciliata Infusorier. IV. *Fysiograf. Sällskap. Handl.; Lunds Univ. Askr.* (1900), 36, 54, 2 pl.
- IDEM. Zur Kenntniss der vergleichenden Morphologie der hypotrichen Infusorien. *Bihang Svenska Vet.-Akad. Handl.* (1900), 26, 1-31, 18 figs.
- IDEM. Zur Kenntniss des Neu-bildungs- und Resorptions vorganges bei der Theilung der hypotrichen Infusorien. *Zool. Jahrb., Abt. f. Anat.* (1901), 15, 1-58, 1 pl. and 28 figs.

ILLUSTRATIONS.

EXPLANATION OF PLATES.

The magnifications given are those which the figures possessed before reduction. Plates IV to VIII have been reduced one-half.

- so, solution plane.
- re, reconstruction plane.
- P, new peristome.
- O, definitive opening of the invaginated new peristome.
- S. O., rudiment of new suboral membranellæ.
- az, old adoral zone.
- AZ, new adoral zone.
- ph, pharynx (old).
- sm, suboral membranellæ (old).

PLATE IV.

- FIGS. 1, 2, 3, and 4. Successive stages in the reconstruction of the meganucleus, and of the invagination of the new peristome. $\times 800$. Camera lucida.
- FIG. 5. Micronuclear spindle of figure 4. $\times 1,600$.
6. Posterior extremity of meganucleus of figure 3. The chromatin reticulum on the anterior side of the solution plane ends very abruptly and evenly. On the posterior side of the reconstruction plane the chromatin fibers reappear; the chromatin is nodular in the posterior part of the nucleus. $\times 1,600$. Camera lucida.
7. Transverse section of a stage corresponding to figure 4. The invagination of the new peristome (P) is seen below the old adoral zone. The new adoral membranellæ stand inside the invagination. $\times 600$. Camera lucida.

PLATE V.

- FIG. 8. The invagination of the new peristome is completely closed. $\times 800$. Camera lucida.
9. Micronucleus of figure 8. Spindle threads connecting the poles could not be seen. $\times 1,600$.
10. The peristomial invagination is reopening at O. At S. O. appears the rudiment of the new suboral group of membranellæ. $\times 800$. Camera lucida.
- 11 and 12. Solution and reconstruction planes. Both these nuclei show a reticulum of extremely fine fibers in the reconstruction plane. These are thickest on the side away from the solution plane; little masses of chromatin can be seen forming at the nodes. $\times 1,600$. Camera lucida.
13. The opening of the new peristome is enlarging. The micronucleus has divided, the two new micronuclei still showing the points at which the nuclear membrane was drawn out as the poles moved apart. $\times 800$. Camera lucida.
14. The new peristome now has a large opening. The two micronuclei are entirely reconstructed, and have assumed their final positions. The reconstruction bands of the meganucleus are approaching each other, while the meganucleus as a whole is condensing and shortening. $\times 800$. Camera lucida.

FIG. 15. The middle portion of the meganucleus of figure 14. $\times 1,200$. Camera lucida.

16. A vertical longitudinal section of the new peristome at a stage corresponding to figure 10. The invaginated new peristome forms an extensive cavity lying directly dorsad (below in the figure) to the old adoral zone (az). The opening of the invagination to the exterior at O is just commencing. The new adoral zone is seen at AZ. $\times 1,000$. Camera lucida.
17. An obliquely transverse section of a stage corresponding to figure 14, passing through the new peristome and its opening, and the old adoral zone (az). $\times 600$. Camera lucida.

PLATE VI.

FIG. 18. The two solution planes of the meganucleus have met. The meganucleus is considerably condensed. $\times 800$. Camera lucida.

19. Anaphase of micronucleus.
20. The solution planes have disappeared and the reconstruction planes have met. $\times 800$. Camera lucida.
21. Late anaphase of micronucleus.
22. The reconstruction planes have disappeared and most of the meganucleus has condensed until the chromatin reticulum is not easily visible. $\times 800$. Camera lucida.
23. At about the same stage as figure 22, but with a less condensed meganucleus. The rudiments of the new cirri have been formed.
24. A transverse section passing through the old peristome, pharynx, adoral zone and suboral membranellæ, and also through the new peristome and its opening to the exterior. The latter is at the base of a depression of the outer surface, and one of its edges is shown in the figure. $\times 400$. Camera lucida.
25. The final stage in the condensation of the meganucleus. Two of the old anal cirri have disappeared; the new cirri are increasing in size.

PLATE VII.

FIGS. 26 to 29. Elongation and constriction of the body and meganucleus; the new peristome is drawing out from above the old, and assuming its definite position.

FIG. 30. Anterior daughter individual immediately after division.

31. Posterior daughter individual immediately after division.

32. First stage in the development of the new cirri. A, B, C, D, E, depressions in which the new cirri of the anterior daughter body will develop; a, b, c, d, e, corresponding depressions of the posterior daughter body; 1, 2, 3, 4, 5, 6, 7, frontal cirri; 8, 9, 10, abdominal cirri; I, II, III, IV, V, anal cirri; L1, L2, left marginal cirri; R1, R2, R3, right marginal cirri.

PLATE VIII.

FIGS. 33 to 36. Successive stages in the development and arrangement of the new cirri, and in the resorption of the old ones. Figures 34, 35, and 36 are drawn from the same individual at intervals of about half an hour.

Fig. 1.

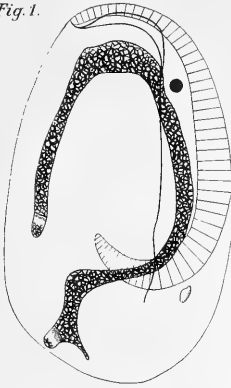

Fig. 2.

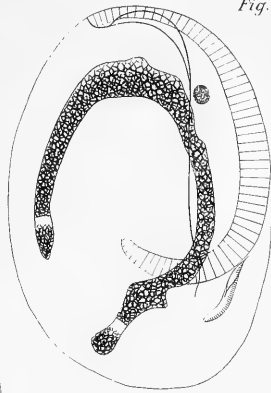

Fig. 5.



Fig. 3.

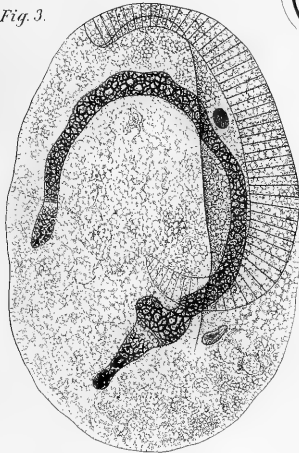

Fig. 4.

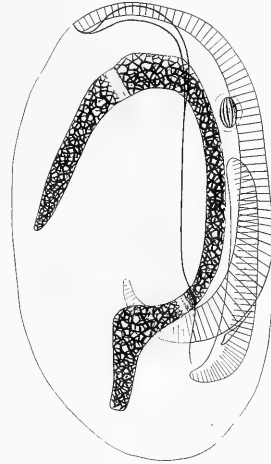

Fig. 6.

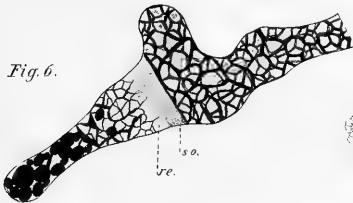
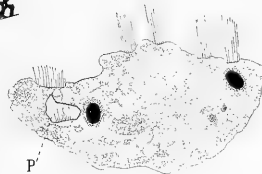
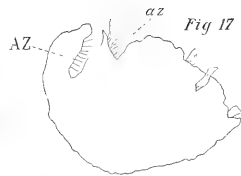
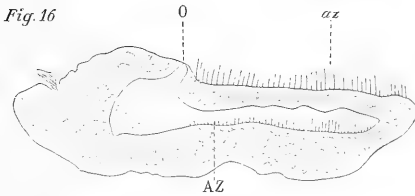
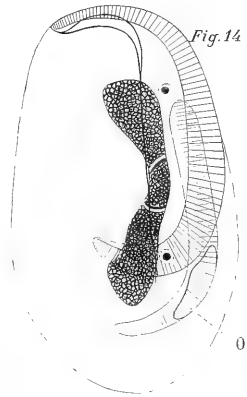
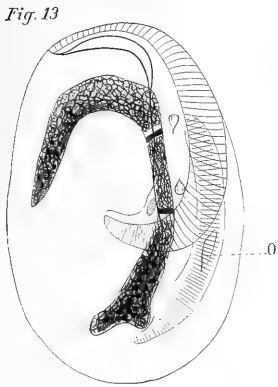
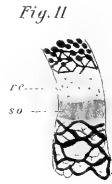
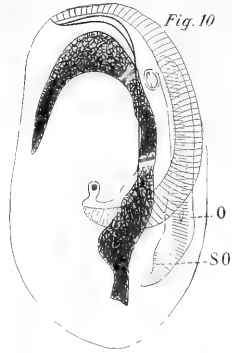
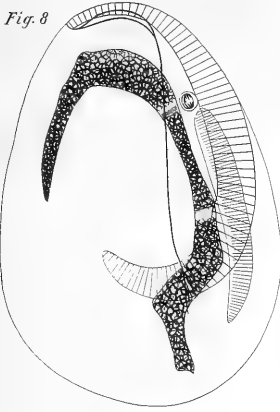

Fig. 7.



L. E. Griffin and T. Espinosa, del.



L. E. Griffin and T. Espinosa, del.

Fig. 18.

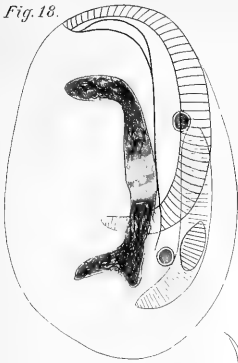

Fig. 21.



Fig. 20.

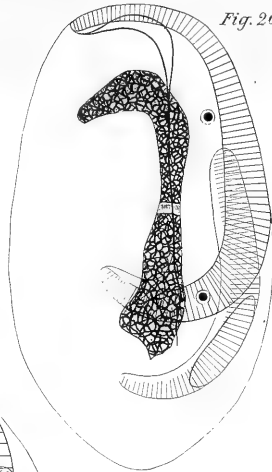

Fig. 25.

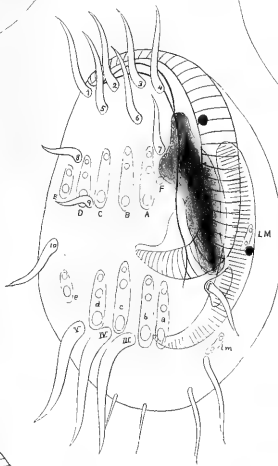

Fig. 19.



Fig. 24.

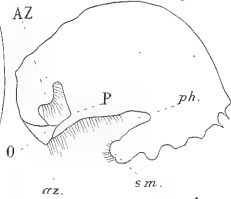

Fig. 22.

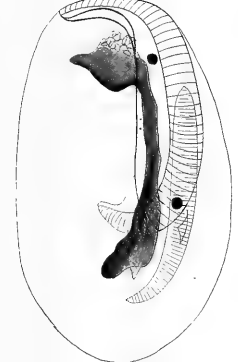
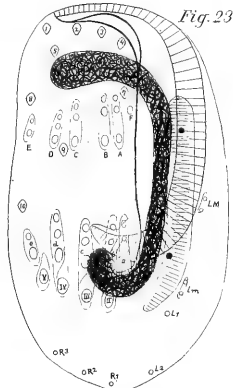

Fig. 23.



L. E. Griffin and T. Espinosa, del.

Fig. 26.

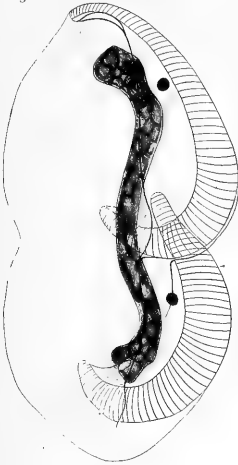

Fig. 27.

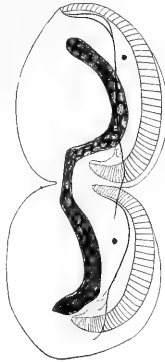

Fig. 28.



Fig. 29.

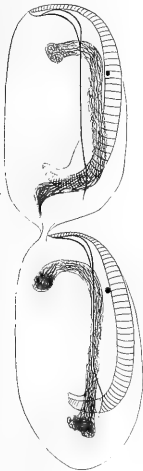

Fig. 30.

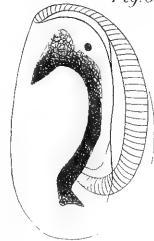

Fig. 31.

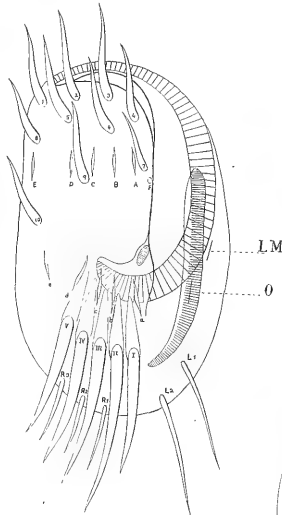
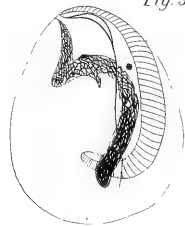
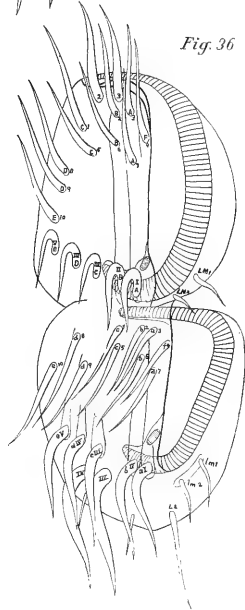
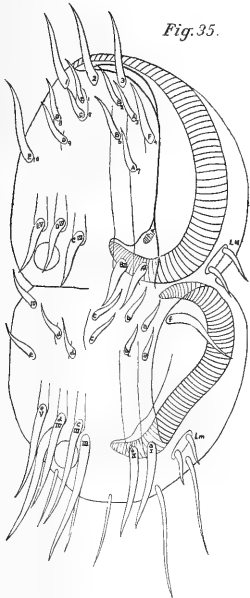
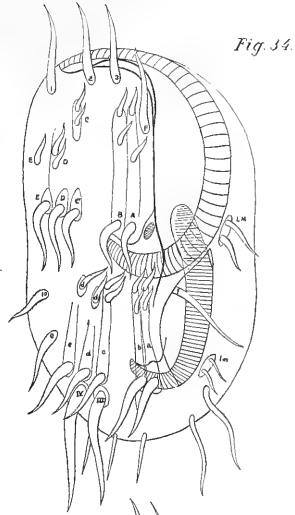
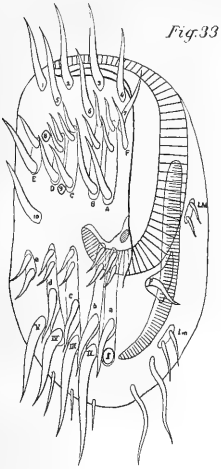

Fig. 32.



L. E. Griffin and T. Espinosa, del.



REVIEW.

Aigrettes and Birdskins. The Truth About Their Collection and Export. By Harold Hamel Smith, editor of "Tropical Life." With a foreword by Sir J. D. Rees, K. C. I. E., C. V. O., M. P. Cloth. Pp. 138. Price: 5 shillings. London: John Bales Sons & Danielson, Ltd. 1910.

This book is written in defense of the bird-millinery trade and in protest against a notification issued in India, in 1902, prohibiting the export from British India of the skins and feathers of all birds other than domestic birds, ostrich feathers and skins, and *bona fide* natural history specimens.

The objection to this order is that while it does not protect the birds from being killed it takes from the poorer classes in India a considerable source of income.

The author claims that the collecting of feathers of wild birds can not be considered cruel, unless it be considered cruel to shoot game for sport, and that, taking the world as a whole, birds are not in danger of extermination, or even of becoming rare.

It is stated that, "unlike the milliners who need the birds only for a few years at a time, whilst the fashion for wearing them lasts, the suppliers to natural history museums and the fishing-tackle trade go on collecting uninterruptedly year after year, as they have no fashion to interrupt their demand."

Members of the Audubon societies and other protectionists will be pleased to learn that should any fear of the extermination of a certain species arise "the trade wisely and very naturally will be only too pleased to collaborate with any official body to keep that particular species out of fashion until their numbers have increased sufficiently to warrant their being used again."

The extermination of some species of birds, such as the herons in Florida, is charged to the advance of civilization and the opening of new country. The author suggests the appointment of a permanent international committee to be consulted at any time, to inquire into reported scarcity of birds, and to ascertain on independent evidence how correct the reports are. The committee should, if necessary, proceed to the center of origin and ascertain the true state of the case.

The frontispiece is a half-tone portrait of the author.

R. C. McG.

INDEX.

(New names are printed in **heavy-faced type**.)

A

- Acanthopneuste borealis* (Blasius), 112.
 Accessory, a new, for dissecting work, 131;
 description of, 131; uses of, 132.
Accipiter gularis (Temminck and Schlegel),
 108.
Achacea combinans Walk., 174.
Achaea cyllota Guen., 174.
Acharana, 180.
 licarsisalis Walk., 180.
 licarsisalis Swinh., 180.
 phœopteris Cuen., 180.
Achilinae, 39.
Acidalia, 177.
 ochrata Scop., 177.
 rufula Swinh., 177.
Acidaliinae, 177.
Acontiinae, 172.
Acronycta, 171.
 leporina Linn., 171.
 sinens Walk., 171.
 sinens Hamps., 171.
Actitis hypoleucos (Linnaeus), 107.
Adiullis, 163.
 benguetana Schultze, 163.
 lunifera Walk., 163.
 samarensis Schultze, 163.
Adoretini, 262.
Adoretus, 262.
 luridus, 262.
 philippinus Pic, 262.
 ranunculus Burm., 262.
 umbrosus Fabr., 262.
Ægalitis dubia (Scopoli), 106.
 alexandrina (Linnaeus), 106.
 peroni (Bonaparte), 106.
Æmene multipunctata Hamps., 169.
Æthopyga flavipectus Grant, 113.
Afrena, 177.
 esmeralda Hamps., 177.
Agonia banksi Weise, 227.
 manilensis Weise, 227.
 vanderpolli Gestro, 146.
Agrotis, 171.
 aristifera Guen., 171.
 biconica Hamps., 171.
 biconica Koll., 171.
 c-nigrum Hamps., 171.
 c-nigrum Linn., 171.
 exigua Koll., 171.
 ingrata Butl., 171.
 segetis Schiff., 171.
 segetis Hamps., 171.
 segetum Leech, 171.
 spiculifera Guen., 171.
 suffusa Treit., 171.
 ypsilon Hamps., 171.
 ypsilon Rott., 171.
Alcedinidae, 109.
Alcedo bengalensis Gmelin, 109.
Alcyone argentata (Tweeddale), 197.
 cyanopterus (Lafresne), 110.
Alpheus avarus Fabr., 97.
Ambassidae, 272.
Ambassis kopsi (Bleeker), 274.
Amia ceramensis Bleeker, 274.
 griffini Seale, 117.
 hyalosoma Bleeker, 274.
 quadrifasciata (Cuv. and Val.), 274.
Amblygobius insignis Seale, 116.
 Anæsthetization of marine animals by using
 magnesium sulphate, 86.
Anas luzonica Fraser, 108.
Anatide, 108.
 Anatomy, racial, in *Taytay*, 1.
Anerastia, 177.
 celsella Walk., 177.
 lotella Hubner, 177.
 pallidicosta Walk., 177.
Anerastiinae, 177.
Angonyx, 167.
 testacea Walk., 167.
 testacea Rothsch., 167.
 Animals, anæsthetization of marine, by
 using magnesium sulphate, 86.
Anomala, 256.
 audradei Heller, 248, 258.
 anoguttata Burm., 258.
 atrocyanea Burm., 259.
 bæri Ohs., 259.
 camarinensis Ohs., 246, 256.
 catenatopunctata Ohs., 244, 256.
 chalchoptera Burm., 259.
 chalibea Burm., 250, 258.
 chloropyga Burm., 252, 259.
 corruscans Chevr., 250, 258.
 dasypyga Burm., 259.
 despumata Ohs., 243, 256.
 encausta Cand., 259.
 exarata Burm., 256.
 flavoscutellata Ohs., 237, 256.

- Anomala heteroglypha* Ohs., 248, 258.
inconsueta Ohs., 250, 259.
infans Ohs., 236, 256.
leotudii Blanch., 242, 257.
macrophthalma Ohs., 237, 256.
nitidissima Blanch., 259.
noctivaga Ohs., 246, 257.
obesa Cand., 259.
ovatula Ohs., 240, 257.
palawana Ohs., 241, 257.
picturata Cand., 258.
planata Cand., 248, 257.
prematura Ohs., 251, 259.
prasina Burm., 259.
proctolasia Ohs., 239, 257.
relucens Har., 250.
schultzeana Ohs., 247, 257.
semperiana Ohs., 241, 257.
smaragdina Eschsch., 259.
sulcatula Burm., 257.
varicolor Gyllenh., 258.
vietipennis Ohs., 245, 258.
whiteheadi Ohs., 243, 258.
- Anomalini*, 256.
- Anous stolidus* (Linnæus), 197.
- Anthreptes griseigularis* Tweed., 221.
- Anthus rufulus* Vieillot, 113, 136, 219.
gustavi Swinh., 113.
- Antipha punctata* All., 223.
- Ants, 69, 71; Philippine, 121; relation of,
 to lycenid chrysalids, 74.
- Aphæna*, 37.
farinosa Spin., 37.
farinosa Weber, 37.
saundersii Walk., 37.
- Aphona farinosa* Burm., 37.
farinosa Weber, 37.
scutellaris White, 37.
- Aphanaria*, 37.
- Aplochloa*, 176.
viridis Warren, 176.
vivilaca Walk., 176.
- Apogonia lutea* Moser, 188.
metallescens Moser, 186.
nigrobrunnea Moser, 187.
rugipennis Moser, 189.
viridana Moser, 187.
- Aphrophorinæ*, 49.
- Apogonichthyidæ*, 274.
- Arctia horsfieldii* Saund., 169.
- Arctiidæ*, 164, 169.
- Arceidæ*, 107.
- Arenaria interpres* (Linnæus), 106.
- Arhopala amantes* Hewitts, 76.
- Arius argyroleuron* (Kuhl and Van Hasselt), 266.
sagor Hamilton, 266.
- Artamidæ*, 112.
- Artamides striatus* (Boddaert), 111, 221.
- Artamus leucorhynchus* (Linnæus), 112, 220.
- Asopia pictalis* Curt., 179.
- Aspidimerus tristis* Weise, 231.
- Aspidomopha miliaris* Fabr., 143.
- Assamia dentata* Buckt., 39.
- Astræa multimaiculata* Moser, 183.
- Astur trivirgatus* (Temminck), 108.
- Atherina forskalii* Rupp., 268.
- Atherinidæ*, 268.
- Attacus ricini* Boisdu., 132.
- Aulacophora quadrimaculata* Chap., 140.
rosea Chap., 140.
uniformis Chap., 223.
- Autoba versicolor* Walk., 172.
- B**
- BANKS, C. S., *Rhynchota Palawanaica*, Part II: Homoptera, 33; Editorial: An Interesting Occurrence with Sticky Grass: *Eragrostis viscosa* Trin., 85; The Polyscopic Cell, 79; A New Accessory for Dissection Work, 131.
- Bantayan Island, formation of, 149; four new species of fishes from, 115; food fisheries of, 151; location of pearl shells at, 150; pearl fishery of, 149; pearl shells from, 150; quality and value of pearl shells from, 151; situation of, 149; value of food fisheries of, 151.
- Barbus elongatus* Seale, 265.
- Barracudas*, Borneo, 268.
- Bass, successful transference of black, into Philippines, 153.
- Batrachostomus microrhynchus* Grant, 136.
- Baza magnirostris* Gray, 197.
- BEAN, ROBERT BENNETT, III. Filipino Types: Racial Anatomy in Taytay. (B). The Women, 1; Paleolithic Man in the Philippines. Homo Philippinensis, 27; Filipino Ears, II: Ears from Malecon Morgue, 191.
- Belonidæ*, 267.
- Birds, additional notes on, from northern Mindanao, 197; collected in Polillo, 103; from northern Luzon and islands of Sabtan and Dalupiri, 219.
- Black bass, apparatus used in transporting, to the Philippines, 153; successful transference of, into Philippines, 153; where secured, 153.
- Black lip pearl oyster, 88.
- Blenina*, 173.
donans Walk, 173.
quinaria Moore, 173.
- Blepharida manilensis* Weise, 142.
- Boarmiinæ*, 176.
- Boiga angulata* (Peters), 213.
cynodon (Boie), 213.
dendrophila (Boie), 214.
- Bolbopsittacus lunulatus* (Scop.), 221.
- Bombyx mori* Linn., 131.
spinula Esp., 171.
- BOOK REVIEWS:
 Check-list of North American Birds, 313.
 Smith, Harold Hamel. *Aigrettes and Birdskins. The Truth about Their Collection and Export*, 337.
- Borneo fishes, 263; barracudas, 268; butterfly-fishes or pomfrets, 269; butterfly-fishes, 283; cardinal fishes, 274; climbing

perches, 272; croakers, 277; cutlass-fishes, 272; eastern spade-fishes, 282; eels, 265; ehippids, 282; flat-heads, 286; founders, ehippids, 282; flat-heads, 286; flounders, 287; goat-fishes, 278; gobies, 285; grunts, 275; half-beaks and flying fishes, 267; kisugos, 279; kittings, 282; leaf-fishes, 283; lizard fishes, 264; mackerels, 270; minnows, 265; mullets, 268; one-spines, 284; pampanos, 270; puffers, poison fishes, 284; ring-fishes, 282; scorpion-fishes, 286; scorpids, 282; sea-basses, 274; sea-horses, 269; sharks, 263; siganids, 203; silversides, 268; slip-mouths, 272; snappers, 275; sting-rays, 264; tangs, 283; therapons, 275; thread-fins, 269; three-spines, 280; urasse-fishes, 281.

Botys licarsialis Walk., 180.
Brachilia acronyctoides Moore, 168.
Brachypteryx polygyna Grant, 137, 138.
Brumus suturalis Fabr., 148.
Bubulcus coromandus (Boddaert), 107, 220.
 Bucerotidæ, 110.
Budytes leucostriatus Homeyer, 113.
Butastur indicus Gmelin, 108.
Butorides javanica (Horsfield), 107.
 Butterfishes or Pomfrets, Borneo, 269.
 Butterfly-fishes, Borneo, 283.
 Buzzard, migration of Tic-Wee, 199.
Bythoscopus biarcuatus, unilineatus, unifascia, Walk., 51.
ferrugineus Walk., 51.
malayus Stål, 51.

C

Cacatua hæmaturopterygia (P. L. S. Müller), 108.
 Cacatuidæ, 108.
Cacomantis merulinus (Scopoli), 186.
Cadra defectella Walk., 177.
Calduba obdenta Walk., 178.
Calidris leucophæa (Pallas), 107.
Callisitta mesoleuca (Grant), 137.
Camponotus (Colobopsis) vitreus Smith, 127.
 (Colobopsis) pubescens Mayr., 127.
femoratus Fabr., 73.
horrens Forel, 127.
maculatus Fabr. subsp. pallidus Sm., 127.
maculatus Fabr. subsp. subnudus Em., 127.
mæschii Forel, 129.
pandava Horsf., 70.
quadrisectus Sm., 73, 127.
rubripes Drury, 69.
 Campophagidæ, 111.
 Canthelea, 178.
ægnusalis Walk., 178.
 Carangidæ, 270.
Caranx brevis Bleeker, 271.
ira (Cuv. and Val.), 271.
secfasciatus (Quoy and Gaimard), 270.
speciosus (Forskål), 270.

Carchariidæ, 263.
 Cardinal fishes, Borneo, 274.
 Cataclysmæ, 176.
conturbata Walk., 176.
conturbata Hamps., 176.
riguata Hübn., 176.
 Caterpillars, myrmecophily of, 69.
Catochrysops cnejus Fabr., 69.
 Celama, 170.
bifascialis Walk., 170.
tæniata Hamps., 170.
tæniata Snell, 170.
 Cell, polyscopic, 79.
 Centromeria, 39.
longipennis Walk., 39.
Centropus unirufus (Cabanis and Heine), 111.
viridis (Scopoli), 111.
 Centrotinæ, 47.
Centrotus dama Germ., 47.
rupicapra Fabr., 48.
taurus Fabr., 48.
terminalis Walk., 48.
vicarius Walk., 48.
Cephalophoneus validirostris (Grant), 137.
Cephaloxys hemelytra Sign., 36.
tersichore Walk., 35.
 Cephonodes, 167.
hylas Linn., 167.
titan Rothsch., 167.
 Cercopidæ, 49.
 Cercopinæ, 50.
Cercopis inclusa Walk., 50.
 Cerynia, 45.
albata Stål, 45.
lutescens Melich., 45.
maria Stål, 45.
maria White, 45.
 Ceryniaria, 45.
Ceyx melanura Kaup, 110.
Chætodon adiergastos Seale, 116.
carens Seale, 115.
occellatus Bleeker, 283.
 Chætodontidæ, 283.
Chaimarrornis bicolor Grant, 136.
Chalcophaps indica (Linnaeus), 106.
 Charadriidæ, 106.
Charadrius fulvus Gmelin, 106.
Charcharias borneensis Seale, 263.
 Chilades, 166.
laeus Cram., 166.
putti Moore, 166.
trochilus Freyer, 166.
trochilus de Nicev., 166.
Chilocorus cerberus Muls., 148.
Chilomenes sexmaculatus Fabr., 148.
Chærodon oligacanthus (Bleeker), 281.
 Chrochiphora, 180.
testulalis Hübn., 180.
 Chrysalis, myrmecophilous Lycænid, from the Philippines, 73.
Chrysocolaptes hæmatribon (Wagler), 111, 136.
Chrysomela bifasciata Hornst., 226.
 Chrysomeliden, 139, 223.
Chrysopela ornata (Shaw), 214.

- Chrysopera, 174.
 combinans Hamps., 174.
 combinans Walk., 174.
 Cienda conica Germ., 36.
 farinosa Weber, 37.
 mannifera Linn., 35.
 quadrıtuberculata Sign., 34.
 sanguinea De Geer, 36.
 sanguinolenta Oliv., 36.
 virescens Oliv., 35.
 Cicadaria, 34.
 Cicadidæ, 33.
 Cicadınæ, 33.
 Ciconiidæ, 107.
 Cinnyrıs henkel Meyer, 220.
 jugularıs (Linnaeus), 113.
 sperata (Linnaeus), 113.
 Citula armatus (Forskål), 272.
 Cisticola exilis (Vigors and Horsfield), 136.
 Cixius pustulatus Walk., 39.
 Cleorına philippınensis Jac., 223.
 Clettharra, 173.
 albonotata Hamps., 173.
 Climbing perches, Borneo, 274.
 Clovia, 49.
 bigoti Sign., 49.
 conifer Walk., 49.
 frenulata Stål, 49.
 vittifrons Stål, 49.
 Clupidæ, 264.
 Cnecedes suturalis Motsch., 141.
 Coccinelliden, 223, 229.
 Coelophora octopunctata Weise, 229.
 sexguttata Weise, 230.
 Colasposoma, 140.
 Coleoptera, verzeichniß von coleopteren aus
 den Philippinen, etc., 139.
 lamellicornia, neue, von den Phil-
 ippinen, 183.
 Collocalia, 103, 136.
 fuciphaga (Thunb.), 221.
 marginata Salvadori, 110.
 troglydtes Gray, 220.
 whiteheadi Grant, 138.
 Columbidae, 105.
 Contributions to lepidopterous fauna of the
 Philippines, 161.
 Coraciidae, 109.
 Corone philippina (Bp.), 114, 220.
 Corvidæ, 114.
 Corynodes indagaceus Chevr., 140.
 Cosmopsaltria, 35.
 doryca Boisd., 35.
 inermis Stål, 35.
 Cosmoscarta, 50.
 heros Fabr., 50.
 inclusa Butl., 50.
 inclusa Walk., 50.
 Cossidæ, 168.
 Cremastogaster deformis Sm., 124.
 modiglianii Emery, var. *clem-*
 ensæ, 125.
 rogenhofferi Mayr., 124.
 simoni Emery, 124.
 Cremastogaster subnuda Mayr, subsp. poli-
 tula Forel, var. *tagala*,
 124.
 Criocerıa 4-notata Fabr., 226.
 Criocerıs semipunctata Fabr., 139.
 Croakers, Borneo, 277.
 Cryptogonus orbiculus Gyllh., 148.
 Cryptolopha nigrorum Moseley, 136, 138.
 Cryptolympana, 34.
 pustulata Fabr., 34.
 ? *varicolor* Dist., 34.
 Cuculidæ, 111.
 Culicicapa ceylonensis (Swainson), 136.
 Curgia, 172.
 nonagrica Walk., 172.
 Cutlass-fishes, Borneo, 272.
 Cyclocorus lineatus (Reinhardt), 211.
 Cynoglossus borneensis (Bleeker), 288.
 kapwāsensis Fowler, 288.
 macrolepidotus Bleeker, 288.
 Cynorta cavifrons Duviv., 224.
 citrina Jac., 224.
 longicornis. Weise, 224.
 quadriplagiata Weise, 225.
 Cyornis philippınensis Sharpe, 111, 220.
 Cyprinidæ, 265.

D

- Dactylispa cladophora Guer., 146.
 Dæda, 46.
 punctilava Banks, 46.
 Dalupiri, birds from island of, 219.
 Darcantasia, 170.
 cuneiplena Walk., 170.
 Dasytidæ, 264.
 Dasytis kuhli (Müller and Henle), 264.
 Dasychira, 169.
 horsfieldi Hamps., 169.
 horsfieldi Saund., 169.
 pubibunda Linn., 169.
 Dasylophus, 221.
 supercilius (Cuvier), 111.
 Davao, quantity of pearl shell taken from,
 89.
 Deilemera, 164.
 evergista Stoll., 164.
 gratia Schultze, 164.
 Demigretta sacra (Gmelin), 107.
 Dendrelaphis cæruleatus Griffin, 213.
 Dendrophis pictus (Gmelin), 213.
 Derbe mæsta Westw., 39.
 Derbinae, 39.
 Diacamma rugosum LeGuill. subsp. geome-
 tricum Sm. var. *viridipurpurea* Emery,
 122.
 Diatomaceæ, 93.
 Dicæidæ, 113.
 Dicæum xanthopygium Tweeddale, 113.
 pygmæum (Kittlitz), 113, 220.
 Dieruridæ, 113.
 Dierurus, 221.
 balicassius (Linnaeus), 113.
 Dietyopharinæ, 38.
 Dietyophora, 38.

- Dictyophora* ? *albititta* Atkins, 38.
albititta Walk., 38.
despecta Walk., 38.
europæa Linn., 38.
hastata Melich., 38.
leptorina Walk., 38.
pallida Atkins, 38.
pallida Don., 38.
percarinata Kirby, 38.
- Dissection work, a new accessory for, 131.
Dissoura episcopus (Boddaert), 107.
DISTANT, W. L., Rhynchota Philippineusia, Part I, 57.
- Dolichoderus bituberculatus* Mayr, 127.
patens Mayr subsp. *pubiventris* Emery, 127.
- Donacia wiepkeni* Ws., 139.
- Dordura, 175.*
aliena Hamps., 175.
aliena Walk., 175.
- Drepane punctata* (Gmelin), 282.
- Drepaulidæ, 282.*
- Dryophis prasinus* Boic, 214.
- Dundubiaria, 34.*
- Dundubia, 35.*
mannifera Linn., 35.
mannifera Stål, 35.
quadrutuberculata Walk., 34.
vaginata Amy. et Lew., 35.
- Dysgonia tineta* Hamps., 175.
- Dysphania, 177.*
palmyra Stoll., 177.
palmyra Swinh., 177.
- E**
- Earias, 170.*
clorana Linn., 170.
frondosana Walk., 170.
grossypii Frauenf., 170.
insulana Boisd., 170.
insulana Rogenh., 170.
insulana Swinh., 170.
siliquana Stainton, 170.
simillima Walk., 170.
smardinana Zell., 170.
tristrigosa Butl., 170.
- Ears, from Malecon Morgue, 191.*
- Eastern spade-fishes, Borneo, 282.*
- Echinoplia striata* Smith, 128.
- EDITORIALS:**
 An Interesting Occurrence with *Sticky Grass: Eragrostis Viscosa* Trin., 85.
 A method of using Magnesium Sulphate for the Anæsthetization of Marine Animals, 86.
- Eels, Borneo, 265.*
- Egretta garzetta* (Linnæus), 107.
- Elaphe erythrura* (Dumeril and Bibron), 213.
- Endotricha, 178.*
flammealis Schiff., 178.
puncticostalis Walk., 178.
- Endotrichinæ, 178.*
- Enmonodia, 175.*
hypopyroides Walk., 175.
pubens Butl., 175.
pubens Walk., 175.
- Ephestia cautella* Hamps., 177.
- Ephippide, 282.*
- Ephippids, Borneo, 282.*
- Ephippus orbis* (Bloch), 282.
- Epicrocis ægnusalis* Hamps., 178.
- Epilachna pusillanima* Muls., 146.
vigintiocto-punctata Fabr., 146.
- Epinephelus sexfasciatus* (Cuv. and Val.), 275.
- Epilemidæ, 175.*
- Equula ruconia* (Hamilton), 272.
- Equulidæ, 272.*
- Eragrostis viscosa* Trin., 85.
- Ercheia, 174.*
cyllaria Cram., 174.
cyllota Guen., 174.
cillota Moore, 174.
- Erystus banksi* Weise, 226.
- Eublemma, 172.*
angulifera Hamps., 172.
respersa Hübn., 172.
versicolor Walk., 172.
versicolor Swinh., 172.
- Euclatichthys crassispinus* (Rüppel), 276.
- Eugoa multipuncta* Hamps., 169.
- Eumyias nigrimentalis* (Grant), 136, 138.
- Euplotes worcesteri*, 291-336; bristles of, sensory, 302; cirri of, 299; cirri of, new, 328; contractile vacuole of, 306; development of the new peristome in, 324; division in, 315; division of the body in, 332; division of micronucleus in, 322; ectosarc of, 303; endosarc of, 305; egestion in, 305; ingestion in, 305; meganucleus in, reconstruction of, 316; membranellæ of, 298; micronucleus in, division of, 322; mouth of, 294; nuclei of, 307; pellicle of, 303; peristome of, new, 324; pharynx of, 294; reconstruction of meganucleus in, 316; sensory bristles of, 302, 331; structure of, 291; systematic position of, 309.
- Eupterotidæ, 162.*
- Eurystomus orientalis* (Linnæus), 109, 220.
- Eusechema palmyra* Hübn., 177.
transversa Moore, 177.
- Everes comyntas* Godt., 71.
- Exocetidæ, 267.*
- F**
- Falconidæ, 108.*
- Fauna, lepidopterous, of the Philippines, 161.*
- Faventia, 39.*
pustulata Stål, 39.
pustulata Walk., 39.
- Fidicina confinis* Walk., 35.
- Filipino ears, II, 191.*
- Filipino types: racial anatomy in Taytay. (B) The Women, I.*

- Fish, care given, en route to the Philippines, 153-155; disposition of, upon arrival in Manila, 155; mosquito-eating fish at Honolulu, 155; transference of black bass to the Philippines, 154.
- Fishes, of Borneo, 263; four new fishes from Bantayan Island, 115.
- Fishery, pearl, of Bantayan, 149; resources, of the Philippine Islands, 89.
- Flatheads, Borneo, 286.
- Flatinae, 45.
- Platoides fumosus Walk., 45.
speculum Walk., 44.
tenebrosus et perforatus Walk., 44.
- Platoidesaria, 47.
- Platta completa Walk., 45.
lyrata Burm., 38.
maria Walk., 45.
tenella Walk., 45.
- Plounders, Borneo, 287.
- Fourmis des Philippines, 121.
- Fulgora graminea Fabr., 38.
Pallida Don., 38.
- Fulgoridae, 37.
- Fulgorinae, 37.
- Fundulus heteroclitus (Linn.), 155.
- G**
- Geaninae, 36.
- Gallinago megala Swinhoe, 107.
- Galleruca bifasciata Fabr., 226.
4-notata Oliv., 226.
- Gallus gallus (Linnaeus), 104.
- Gambusia affinis (B. and G.), 155.
- Gargara, 48.
genista Fabr., 48.
pygmaea Walk., 48.
- Gargaria, 48.
- Gargetta, 168.
costigera Walk., 168.
- Gasterotokeus biaculeatus Bloch, 269.
- Gazza minuta (Bloch), 272.
- Gelechiinae, 165.
- Gennadius stoliczkae (Day), 286.
- Geometridae, 165, 176.
- Geometrinae, 177.
- Gerridae, 277.
- Glossogobius aglestes Jordan and Seale, 286.
- Glottis nebularius (Gunnerus), 107.
- Gnatholipis callurus Jordan and Seale, 285.
- Goat-fishes, Borneo, 278.
- Gobies, Borneo, 285.
- Gobiidae, 285.
- Gold lip pearl oyster, 88.
- Graphiphora o-nigrum Steph., 171.
- Grass, an interesting occurrence with sticky, 85.
- GRIFFIN, LAWRENCE E., Editorial: A Method of Using Magnesium Sulphate for the Anaesthetization of Marine Animals, 86; The Pearl Fishery of Bantayan, 149; A List of Snakes from the Island of Pohnu, P. I., with Descriptions of a New Genus and Two New Species, 211; Euplores Worcesteri sp. nov. I. Structure, 291; Euplores Worcesteri sp. nov. II. Division, 315.
- Grunts, Borneo, 275.
- Gyrtona, 173.
hylusalis Walk., 173.
lapidaria Walk., 173.
- H**
- Haenulidae, 276.
- Halcyon chloris (Boddaert), 110.
gularis (Kuhl), 110.
lindsayi (Vig.), 220.
- Half-beaks and flying fishes, Borneo, 267.
- Haliastur intermedius Gurney, 108.
- Hamodes, 175.
aurantiaca Guen., 175.
aurantiaca Hamps., 175.
attacicola Swinh., 175.
dicistriga Moore, 175.
propitia Guen., 175.
- Haplodon, 211.
philippinensis Griffin, 212.
- Haplosynyx smaragdipennis Chevr., 141.
- Harmonia octo-maculata Fabr., 147.
- Helodromas ochropus (Linnaeus), 107.
- Hemibugarus, 214.
- Hemichelidon griseosticta Swinhoe, 111.
- Hemirhamphus gaimardi (Cuv. and Val.), 267.
- Hemisphaerius, 41.
parenthesis Banks, 41.
stall Banks, 43.
transfasciatus Banks, 42.
trimaculatus Banks, 43.
- Herodias timoriensis (Lesson), 197.
- Hepalidae, 283.
- Hepetus matoides (Cuv. and Val.), 283.
- Hesperidae, 167.
- Heteractitis brevipes (Vieillot), 107.
- Heteraspis billardieri Crotch, 148.
- Heterocera, 167.
- Hippocampus kuda Bleeker, 269.
- Hirundinidae, 111.
- Hirundo gutturalis Scopoli, 111.
striolata (Boie), 135.
- Hisha xanthoptera Bleeker, 264.
- Holuthurians, dried, exported from Bantayan, 151; value of, 151.
- Homo heidelbergensis, 27.
philippinensis, 27.
- Homesoma derasella Swinh., 178.
gratella Walk., 178.
- Homoptera, 33.
- Honolulu, cost of introducing fish at, 157; mosquito-eating fish at, 155; success of venture at, 157.
- Hoplasoma philippinensis Jac., 140.
- Hoplia maculifera Moser, 185.
philippinensis Moser, 184.
- Horornis seebohmii (Grant), 137, 138.
- Huechys, 36.
sanguinea Amy. et Serv., 36.
sanguinea De Geer, 36.
- Huechysaria, 36.

- Hurria rhynchops* (Schneider), 213.
Hypetra, 174.
 aliena Walk., 175.
 bubo Hübn., 174.
 bubo Hamps., 174.
 noctuides Guen., 174.
Hydrocampine, 179.
Hyloterpe albiventris Grant, 137, 220.
Hypernaria discistriga Moore, 175.
Hyperperissa, 165.
 aurantiaca Semper, 165.
 pulchella Schultz, 165.
Hypopyra grandæva Feld., 175.
 persimilis Moore, 175.
 pudens Walk., 175.
Hypotenidia torquata (Linnaeus), 106.
Hypothymis occipitalis (Vigors), 111.
- I**
- Iole*, 221.
 gularis (Pucheran), 112, 136, 138, 221.
Irena cyanogastra Vigors, 112.
 Island of Bantayan, four new species of fishes from, 115; situation of, 149.
 Island of Dalupiri, birds from, 219.
 Island of Sabtan, birds from, 219.
 Island of Poyillo, 103; snakes from, 211.
Issina, 41.
- J**
- Jada*, 39.
 maculipennis Banks, 39.
 nitagalensis Dist., 39.
Jassidae, 50.
Jassina, 51.
Jassus, 52.
 elegans Dist., 52.
 nervosus Fabr., 52.
Jassusaria, 52.
Jivatma, 41.
 metallica Dist., 41.
 triangulata Banks, 41.
Johnius borneensis (Bleeker), 279.
 vogleri Bleeker, 280.
- K**
- Kitings*, Borneo, 282.
Kisugos, Borneo, 281.
Kittacincla, 221.
 luzoniensis (Kittlitz.), 220.
 parvimaculata McGregor, 112.
Kolla, 51.
 insignis Dist., 51.
 tripunctifrons Banks, 51.
- L**
- Labridæ*, 281.
Lacoptera fallax Weise, 145.
 insulana Weise, 145.
 manilensis Weise, 144.
Lactarius (Bloch and Schneider), 270.
Lalage niger (Forster), 111.
Lamprocorax panayensis (Scopoli), 114.
Laniidæ, 112.
Laridæ, 106.
Larentia conturbata Walk., 176.
Larentiinae, 165, 176.
Lasiocampidæ, 168.
Lates calcarifer (Bloch), 275.
Leaf-fishes, Borneo, 283.
Lebeda plagifera Walk., 168.
Ledrinae, 50.
Leiognathus blochii Cuv. and Val., 273.
 caballa (Cuv. and Val.), 273.
 edentulus Bloch, 273.
 splendens (Cuvier), 273.
Leis dimidiata Fabr., 232.
 dunlopi Crotch., 232.
Lema semperi Jac., 139.
Lepidota corpulenta Moser, 185.
Lepidoptera, contributions to the lepidopterous fauna of the Philippines, 161; new Philippine, 161; species of, hitherto unrecorded from the Philippines, 166.
Lepidopterous fauna, contributions to, of the Philippines, 161.
Leptobelus, 47.
 dama Germ., 47.
 dama Stål, 47.
Leptocentrus, 48.
Leptocentrus, 48.
 gazella Bukt., 48.
 taurus Fabr., 48.
 taurus Stål, 48.
Leptopsaltria, 34.
 quadrituberculata Sign., 34.
 quadrituberculata Stål., 34.
 tuberosa Sign., 34.
Lethrinus amboinensis Bleeker, 277.
Leucania, 172.
 inframicans Hamps., 172.
 nigrilinea Leech, 172.
Leucotreron leclancheri (Bp.), 220.
 marchei (Oustalet), 105.
Lichtensteinipicus funebris (Valenciennes), 111.
Limacodidæ, 168.
Literature, III, Philippine ornithological, 203.
Lithosiinae, 164, 169.
Liza caeruleomaculatus (Lacépède), 268.
Lizard fishes, Borneo, 264.
Lomotropa, 179.
 costiflexalis Guen., 179.
 costiflexalis Led., 179.
Lophopinae, 40.
Lophotriorchis kieniri (Geoffroy St. Hilaire), 197.
Loriculus philippensis (P. L. S. Müller), 109, 221.
Lutera, 262.
 nigromaculata Obs., 236, 262.
Lutianidæ, 275.
Lutianus erythropterus Bloch, 275.
 fulvisamma (Forskål), 275.
 vitta (Quoy and Gaimard), 275.
Luzon, birds, from northern, 219.
Lycæna argyrogonomon Bergstr., 71.
 elna Hetwits., 166.

- Lycena gaika* Trimen, 166.
pseudargiolus Boisds., 70.
putti Kollar, 166.
trochilus Freyer, 166.
- Lycænid* larvæ, ant-attracting organs of, 69 ;
 secreting pores of, 70.
- Lycænidæ*, 161, 166.
- Lyclene semifascia* Moore, 170.
- Lymantriidæ*, 162, 169.
- Lystra farinosa* Fabr., 37.
- M**
- Maceda*, 173.
discalis Walk., 173.
mansueta Moore, 173.
mansueta Walk., 173.
- Machærota*, 49.
ensifera Burm., 49.
- Machærotinæ*, 49.
- Mackerels*, Borneo, 270.
- Macronota luctuosa* Voll., subsp. *palawanica*, 183.
- Macropygia tenuirostris* Bonaparte, 105, 220.
- Magnesium sulphate*, a method of using, for the anæsthetization of marine animals, 86.
- Malaia*, 253, 260.
thoracica Ohs., 253, 260.
- Malecon Morgue*, ears from, 191.
- Mallienesia latipinna* La S., 155.
- Man*, Paleolithic, in the Philippines, 27.
- Mandesa*, 49.
amplificata Dist., 49.
vittifrons Stål, 49.
- Manoba*, 169.
fractilinea Snell., 169.
implens Walk., 169.
- Mareca penelope* (Linnaeus), 197.
- Margaritifera margaritifera* (Linnaeus), 88.
maxima Jamson, 88.
vulgaris Schum., 95.
- Margaroninæ*, 179.
- Marine animals, anæsthetization of, by magnesium sulphate, 86.
- Maruca testularis* Moore, 180.
- MCGREGOR, RICHARD C., Birds from Pauai and Mount Pulog, Subprovince of Benguet, Luzon, 135 ; Additional Notes on Birds from Northern Mindanao, Philippine Islands, 197 ; Note on the Migration of the Tic-Wee Buzzard in the Philippine Islands, 199 ; Philippine Ornithological Literature, III, 203 ; Birds from the Coast of Northern Luzon and from the Islands of Sabtan and Dalupiri, 219.
- Megapodiidæ*, 104.
- Megapodius cumingi* Dillwyn, 104.
- Membracidæ*, 47.
- Membracis rupicapra* Fabr., 48.
taurus Fabr., 48.
tricornis Hardw., 48.
- Menippus viridis* Duvivier, 141.
- Mestleta angulifera* Moore, 172.
- Metriona manilensis* Weise, 229.
trivittata Fabr., 146.
- Microenaria*, 47.
- Microbuglossus humilis* (Cantor), 287.
- Microcossus*, 180.
mackwoodii Moore, 180.
- Micropodidæ*, 110.
- Micropus pacificus* (Latham), 219.
- Microscopical accessory*, 79.
- Micropterus salmoides* (Lacépède), 153.
- Migration of the Tic-wee Buzzard in the Philippine Islands, 199.
- Miltchrista*, 170.
miniata Forst., 170.
semifasciata Hamps., 170.
semifascia Walk., 170.
- Mimela*, 252.
blumei Hope, 260.
maculicollis Ohs., 260.
palawana Ohs., 252, 260.
- Mindanao, additional notes on birds from northern, 197.
- Minnows*, Borneo, 265.
- Mogannia*, 36.
conica Germ., 36.
conica Stål, 36.
histrionica Uhler., 36.
illustrata Amy. et Sew., 36.
indicans, *ignifera* et *avicula* Walk., 36.
recta Walk., 36.
tersichore Atkins, 35.
venutissima Stål, 36.
- Moganniaria*, 36.
- Mogarras*, Borneo, 277.
- Monocanthidæ*, 284.
- Monocanthus chinensis* (Bloch), 284.
- Monodactylus argenteus* (Linnaeus), 282.
- Monolepta bifasciata* Hornst., 225.
 (Candezea) *bifoveolata* Weise., 141.
rubrosignata Bohem., 226.
- Monomorium* (*Martia*) *banksi* Forel, 123.
floricola Jerdon, var. *philippinensis*, 123.
 (*Martia*) *orientalis* Mayr, 123.
- Monotaxis*, 164.
montanus Schultze, 164.
trimaculata Hamps., 164.
- Morgue*, ears from Malecon, 191.
- MOSER, J., Neue Coleoptera Lamellicornia Von Den Philippinen, 183.
- Mosquito-eating fish*, 155.
- Motacilla melanope* Pallas, 113.
- Motacillidæ*, 113.
- Mullets*, Borneo, 268.
- Mullidæ*, 278.
- Munia cabanisi* Sharpe, 136, 220.
jağori Martens, 113, 219.
- Murænesocidæ*, 265.
- Murænesox cinereus* (Forskål), 265.
- Mugil belanak* Bleeker, 268.
- Mugilidæ*, 268.
- Muscadivores chalybura* (Bonaparte), 105.
- Muscicapula luzoniensis* Grant, 136.
westermanni Sharpe, 136.
- Muscicapulidæ*, 111.
- Musotima*, 179.
anulalis Feld, 179.
suffusalis Hamps., 179.

- Myelois bractiatella* Walk., 179.
Myristicivora bicolor (Scopoli), 105.
Myrmecophilus Lycænid Chrysalis from the Philippines, 73.
 Myrmecophily of Caterpillars of Catochrysops *cnejus* Fabr., 69.
- N**
- Nagoda, 168.
 nigricans Moore, 168.
Nannocnus eurhythmus (Swinhoe), 107.
Natrix spilogaster Boie, 211.
Nectariniidæ, 113.
Nemipterus upeneoides (Blecker), 275.
Nephesa, 46.
 rosea Spin., 46.
 rosea Amy. et Serv., 46.
Nephepteryx, 178.
 clientella Zell., 178.
 proximalis Walk., 178.
 syntaractis Turn., 178.
 New genus of snakes, from Island of Polillo, 211.
 New lepidoptera, 161.
 New species, of snakes, from Island of Polillo, 211; four, of fishes of Borneo, 263; four, of fishes from Bantayan Island, 115.
Ninox philippinensis Bonaparte, 108.
Noctua c-nigrum Schiff., 171.
 segetum Schiff., 171.
 suffusa Fabr., 171.
 ypsilon Rott., 171.
Noctuidæ, 171.
Nola tæniata Snell., 170.
Nolinæ, 170.
 Note on the migration of the Tic-wee Buzzard in the Philippine Islands, 199.
 Notes, additional, on Birds from northern Mindanao, 197.
Notodontidæ, 168.
Numenes, 162.
 insolita Schultze, 162.
Numenius variegatus (Scopoli), 106.
Nyctcolinæ, 170.
Nycticorax manillensis Vigors, 107.
Nyctipao, 174.
 crepuscularis Linn., 174.
 stringipennis Moore, 174.
Nymphula, 179.
 nymphæta Linn., 179.
 turbata Butl., 179.
- O**
- Octhodromus geoffroyi* (Wagler), 106.
 mongolus (Pallas), 106.
Odonestis, 168.
 plagifera Walk., 168.
 plagifera Hamps., 168.
Odontomachus banksi Forel, 121.
 infandus Sm., 122.
Odontoponera transversa Sm., 122.
Oedicnemidæ, 107.
 OHAUS, FR., Die Ruteliden der Philippinischen Inseln, 233.
Omphisa, 180.
- Omphisa anastomosalis* Guen., 180.
 anastomosalis Hamps., 180.
 One-spines, Borneo, 284.
 Ophisma atticicola Walk., 115.
 Orhopala; 74.
 Oriolidæ, 113.
 Oriolus acrorhynchus Vigors, 113, 220.
 Ornithological literature, III, Philippine, 203.
 Orphnophanes, 179.
 albisignalis Hamps., 179.
 eucerasalis Walk., 179.
 Ortalia pusilla-mæsta Ws., 232.
 Orthorhamphus magnirostris (Vieillot), 107.
 Orthosia sinens Walk., 171.
 Orthotomus chloronotus Grant, 220.
 Orudiza, 175.
 proteclaria Walk., 175.
 Orzonoba, 176.
 clélia Cram., 176.
 clélia Moore, 176.
 Osmotreron axillaris (Bonaparte), 105, 220.
 Otolithus dolorosus Seale, 280.
 maculatus (Kuhl and Van Hasselt), 279.
 orientalis Seale, 281.
 Otomela lucionensis (Linnæus), 112.
 Oxyurichthys cristatus (Day), 285.
 Oyster shell, price of, 89; quantity taken in one year from Davao pearl bed, 89.
- P**
- Pachyzancla licarsisalis* Hamps., 180.
Paduca, 167.
 glandulosa Dist., 167.
Palawan, Rhynchota Palawanica, Part II, 33.
 Paleolithic man in the Philippines, 27; description of, 28; discovery of, 27.
Pampanos, Borneo, 270.
Papilionidæ, 167.
Papilioninæ, 167.
Papilio, 167.
 neptunus Guér., 167.
 priamus Linn., 167.
 xanthus Rothsch., 167.
 xuthus Bingham, 167.
 xuthus Linn., 167.
Parastasia, 261.
 canaliculata Westw., 261.
 confuens Westw., 261.
 discolor Westw., 261.
 indica Ohs., 262.
 nigriceps Westw., 262.
 nigroscutellata Ohs., 262.
 nonfriedi Ohs., 262.
 westwoodi Waterh., ex Westw., 262.
Pardaliparus elegans (Lesson), 137.
 Pearl fishing, laws relating to Philippine, 94.
 Pearl fishery of Bantayan, 149.
 Pearl shells from Bantayan island, 150; location of, 150; value of, 150-151.
 Pearling banks, Philippine, 90.
 Pearling fleet of Zamboanga, 89.

- Pearl oyster, enemies of, 93; life history of, 92; movements of, 93; transplanting and cultivating the Philippine, 94; varieties of Philippine, 88.
- Pearls, artificial production of, 97; composition of, 95; determination and valuation of, 99; yield of, in Philippines, 95.
- Pearls and pearl fisheries, Philippine, 87.
- Pelargopsis gigantea Walden, 109.
- Pempelia cautella Walk., 177.
- Penelopides **subnigra** McGregor, 110.
- Pericrocotus cinereus Lafresneye, 111.
- Perigonia testacea Walk., 167.
- Peristeride, 106.
- Pernis pilorhyncus (Temminck), 108.
- Petaloccephala, 50.
- philippina* Stål, 50.
- Petrophila *manillensis* (J. R. Forster), 112.
- Phalæna, 177, 171.
- clelia* Cram., 176.
- Phapitreron *amethystina* Bonaparte, 105.
- leucotis* (Temm.), 220.
- Phasianide, 104.
- Pheidologeton *diversus* Jerdon, 123.
- Phenice, 39.
- fritillaris* Westw., 39.
- moesta* Stål, 39.
- moesta* Westw., 39.
- Philampeline, 167.
- Philippine ants, 121.
- Philippine pearl oyster, varieties of, 88.
- Philippine pearling banks, 90; currents in, 90.
- Philippine pearls and pearl fisheries, 87.
- Philippine Ornithological Literature, III, 203.
- Philippine Snakes from the Island of Polillo, 211.
- Phlegenas *luzonica* (Scopoli), 106.
- Photoscotisia, 176.
- miniosata* Hamps., 176.
- miniosata* Walk., 176.
- Phthonoloba, 176.
- benguetana* Schultze, 165.
- decussata* Moore, 176.
- Phycidopsis, 172.
- albovittata* Hamps., 172.
- Phycita, 178.
- clientella* Hamps., 178.
- proximalis* Hamps., 178.
- proximalis* Walk., 178.
- spissicella* Fabr., 178.
- Phyllotreta *serricornis* Duviv., 142, 226.
- Phytorus *latus* Weise, 139.
- Picidæ, 111.
- Pionea *anastomosalis* Guen., 180.
- Pisobia *ruficollis* (Pallas), 107.
- Pitane *fractilinea* Snell., 169.
- Plagiolepis *longipes* Jerdon, 127.
- Planesticus *thomassoni* (Grant), 137.
- thomassoni* (Seebohm), 138.
- Platacidæ, 283.
- Platax *orbicularis* (Forskål), 283.
- Platycephalidæ, 286.
- Platycephalus *indicus* (Linnaeus), 286.
- Platynaspis *nigra* Ws., 232.
- Platypleura, 33.
- fulviger* Walk., 33.
- stridula* Linn., 33.
- Platythyrea *inermis* Forel, 122.
- Pleuronectidæ, 287.
- Ploceidæ, 113.
- Plotosidæ, 266.
- Plotus *angullaris* (Bloch), 266.
- Pochazia, 44.
- fasciata* Fabr., 44.
- guttifera* Walk., 44.
- Pœciliidæ, 155.
- Pœciliopsaltria *fulviger* Stål, 33.
- Pœcilopectera *maria* White, 45.
- Poisson-fishes, Borneo, 284.
- Polillo, area of, 103; birds of, 103; island of, location of, 103; snakes from, 211.
- Polinemidæ, 269.
- Polioætus *ichthyætus* (Horsfield), 197.
- Poliolophus *urostictus* (Salvadori), 112.
- Polycaulus *elongatus* (Cav. and Val.), 286.
- Polydactylus *zophomus* Jordan and McGregor, 269.
- Polynemus *tetradaactylus* Shaw, 269.
- Polyneuraria, 33.
- Polyrhachis *armata* LeGuillon, 128.
- bicolor* Smith. var. **concolor**, 129.
- bihamata* Drury, 128.
- cyaniventris* Smith, 128.
- dives* Smith, 71.
- sex-spinosa* Latr. var. *esuriens* Em., 128.
- textor* Smith var. *æqualis*, 129.
- Polyscopic cell, 79; cell holder, 81; method of use, 81; method of preparation of, 80; reason for, 79; useful to entomologists and general biologists, 79; uses of, 82.
- Popillia, 260.
- cetrata* Newm., 260.
- conopyga* Ohs., 260.
- depressa* Kraatz., 261.
- depressiuscula* Kraatz., 261.
- mcgregori* Ohs., 254, 261.
- mutans* Newm., 261.
- oculata* Ohs., 255, 261.
- scalpta* Newm., 261.
- variabilis* Kraatz., 261.
- Porgies, Borneo, 277.
- Prenolepis *longicornis* Latr., 127.
- Prioniturus *montanus* Grant, 136, 138.
- Priopis *gymnocephalus* Lacépède, 274.
- Prioptera *immaculata* Wagener, 228.
- immaculata* Wagner, var. **fusco-punctata**, 228.
- sinuata* Oliv., 228.
- Pristipoma *hasta* Bloch, 276.
- therapon* Bleeker, 276.
- Promecotheca *cumingi* Baly, 146.
- Prorodeca *angulifera* Walk., 169.
- Prosopodasys *trachinordes* (Cuv. and Val.), 286.
- Psammodynastes *pulverulentus* (Boie), 214.
- Psammoperra *waiigiensis* (Cuv. and Val.), 274.

- Pseudoamia polystigma* Bleeker, 274.
Pseudomalia, 260.
 flavipilosa Ohs., 260.
 pilifera Burm., 260.
 semperi Kraatz, 260.
 tagala Heller, 260.
- Pseudoganisa**, 162.
 currani, Schultze, 162.
- Pseudophana lyrata* Burm., 38.
 pallida Westw., 38.
- Pseudorhombus javanicus* Hamilton, 287.
Pseudosciaena anea (Bloch), 280.
 diacanthus (Lacépède), 279.
- Psittacidae**, 108.
Psylliodes splendida Harold, 142.
- Ptylus conifer* Walk., 49.
 frenulatus Stål, 49.
 simulans Walk., 49.
- Puffers, poison fishes, Borneo**, 284.
- Pycnonotidae**, 112.
Pycnonotus golavier (Scopoli), 136, 220.
- Pygospila costiflexalis* Guen., 179.
- Pyralidae**, 177.
Pyralinae, 179.
Pyralis, 179.
 ? *agnusalis* Walk., 178.
 farinalis Linn., 179.
 pictalis Curt., 179.
 pronealis Walk., 179.
 proximalis Walk., 179.
- Pyraustinae**, 180.
Pyrops perpusilla Walk., 41.
Pyrotrogon ardens (Temminck), 110.
- Pyrrhula leucogenys* Grant, 135, 137, 138.
Python reticulatus (Schneider), 211.
- Q**
- Quadrifinae**, 174.
- R**
- Racial anatomy in Taytay, 1.
Radinacra euthusa Hamps., 172.
- Rallidae**, 106.
Rastrelliger brachysomus (Bleeker), 270.
- Resources, fishery, of the Philippine Islands**, 87.
- REVIEWS (BOOK)** :
 Check-list of North American Birds, 313.
 Smith, Harold Hamel. *Aigrettes and Birdskins. The Truth about Their Collection and Export*, 337.
- Rhabdornis mystacalis* (Temm.), 221.
Rhinogobius caninus (Cuv. and Val.), 285.
 nebulosus (Forskål), 285.
- Rhinomyias insignis* Grant, 136.
Rhipidura cyaniceps (Cassin), 136, 138, 220.
 nigritorquis Vigors, 111.
- Rhisina puncticostalis* Walk., 178.
Rhodophea, 178.
 advenella Zinck, 178.
 heringii Rag., 178.
- Rhopalocera*, 166.
Rhyacophilus glareola (Linnæus), 107.
Rhynchota Palawanica, Part II : Homoptera, 33. *Philippinensia*, Part I, 57.
- Rodolia podagrica* Ws., 232.
 rufopilosa Muls., 232.
- Resella fragilis* Swinh., 170.
- Ricania**, 44.
 fenestrata Fabr., 44.
 fumosa Stål, 45.
 fumosa Walk., 45.
 guttifera Stål, 44.
 malaya Stål, 44.
 proxima Melich., 45.
 rosea Spin., 46.
 speculum Stål, 44.
 speculum Walk., 44.
 subsINUATA Stål, 44.
 tæniata Stål, 44.
- Ricaninae**, 44.
Ricaninaria, 44.
Ricine suffusa Walk., 169.
- Ring-fishes, Borneo**, 282.
Ruteliden, der Philippinischen Inseln, 233.
Rutelini geniuni, 261.
- S**
- Sabtan, birds from island of**, 219.
Salurnis, 45.
 granulosa Stål, 45.
- Sarcops calvus* (Linnæus), 114.
Sarothripinae, 173.
Saurida tumbil (Bleeker), 264.
- Scamandra**, 37.
 hermione Stål, 37.
 rosea, Guér., 37.
- Scatophagidae**, 282.
Scatophagus argus (Gmelin), 282.
- SCHULTZE, W., *Contributions to the Lepidopterous Fauna of the Philippines*, 161.
- Sciænidae**, 279.
Scolopsis vosmaeri Bleeker, 276.
- Scombridae**, 270.
Scomberoides lysan (Forskål), 272.
- Scorpenidae**, 286.
Scorplon-fishes, Borneo, 286.
Scorpididae, 282.
Scorpidæ, Borneo, 282.
 Sea-basses, Borneo, 274.
 Sea-horses, Borneo, 269.
- SEALE, ALVIN, *The Fishery Resources of the Philippine Islands. Part III. Pearls and Pearl Fisheries*, 87; *Descriptions of Four New Species of Fishes from Bantayan Island, Philippine Archipelago*, 115; *The Successful Transference of Black Bass into the Philippine Islands, with Notes on the Transportation of Live Fish Long Distances*, 153.
- Serida**, 40.
 ferrens Dist., 40.
 ferrens Walk., 40.
 latens Walk., 40.
- Serranidae**, 274.
Sessinæ, 167.
Setina semifascia Walk., 170.
- Sharks, Borneo**, 263.
Siganidae, 283.
Siganids, Borneo, 283.

- Siganus albopunctatus* (Temminck and Schlegel), 284.
fuscens (Houttuyn), 284.
hexagonata Bleeker, 284.
javus (Linnaeus), 283.
vermiculatus Kuhl and Van Hasselt, 283.
- Sillaginidae, 281.
Sillago sihama (Forskål), 281.
 Siluridae, 266.
 Silversides, Borneo, 268.
Siriocauta testulalis Led., 180.
 Slip-mouths, Borneo, 272.
 Snakes, Philippine, from the Island of Polillo, 211.
 Snappers, Borneo, 275.
Solenopsis geminata Forel, 123.
Sorocostia mesozana Lucas, 170.
 Sparidae, 277.
Sparus calamara Russell, 277.
Spatula clypeata (Linnaeus), 108.
 Sphæroderma, 142.
Spheroides lunaris (Bloch), 285.
 Sphingidae, 167.
 Sphyrænidae, 268.
Sphyræna toxæusa Forster, 268.
Spirama pudens Hamps., 175.
Spilornis holospilus (Vigors), 108.
Spiloticthys pictus (Thunberg), 276.
Squatarola squatarola (Linnaeus), 106.
Stenia testulalis Guen., 180.
Sterna sinensis Gmelin, 106.
Stethorus pauperculus Ws., 232.
 rotundatus Motsch., 232.
Sticholotis banksi Weise, 230.
 ovata Weise, 230.
- Sticky grass, an interesting occurrence with, 85.
 Stictane fractilinea Hamps., 169.
 Stictopterinae, 173.
 Sting-rays, Borneo, 264.
Streptopella dussumieri (Temminck), 106, 220.
 Strigidæ, 108.
 Stromateidæ, 269.
Stromateus cinereus (Bloch), 269.
 Sturnidæ, 114.
 Sylviidæ, 112.
 Syngnathidæ, 269.
 Synodontidæ, 264.
Synonycha grandis Thunb., 148.
 Sypna, 174.
 ochreicilia Hamps., 174.
 omicronigera Guen., 174.
 punctosa Hamps., 174.
 punctosa Walk., 174.
- T**
- Tachornis pallidior* McGregor, 110.
Tachysurus venosus (Cuvier and Valenciennes) 266.
 Tangs, Borneo, 283.
Taenygnathus freeri McGregor, 103, 108.
 lucionensis (Linnaeus), 108.
- Tartessus*, 51.
 ferrugineus Stål, 51.
 ferrugineus Walk., 51.
 feberi Stål, 51.
 malayus Stål, 51.
- Tartessusaria*, 51.
 Tarucus, 161.
 leopardus Schultze, 161.
 thcophrastus Fabr., 69.
- Taytay, racial anatomy in, 1.
 Taytay women, branchial index, 9; comparison of, with women of northeastern Siberia, 1; crural index, 10; disease and species, 15; ear form, 14; head and face, 12; morphology, 15; omphalic index, 8; stature of types of, 3; trochanter height, 7.
- Tavia punctosa* Walk., 174.
Tetraodon fluviatilis (Hamilton), 285.
 immaculatus (Bloch and Schneider), 284.
 Tetraodontidæ, 284.
Tettigonia impudica Sign., 50.
 impudica? Stål, 50.
 sanguinolenta Fabr., 36.
Tettigoniella, 50.
 impudica Sign., 50.
- Tettigoniellinae, 50.
Thea cincta Fabr., 147.
 Theraponidæ, 276.
Therapon jarbua (Forskål), 277.
 puta (Cuv. and Val.), 277.
 quadrilineatus (Bloch), 277.
- Therapons, Borneo, 276.
 Threadfins, Borneo, 269.
 Three-spines, Borneo, 284.
Thriponax javensis (Horsfield), 136.
Thysanophrys bobosok (Bleeker), 287.
 scaber (Linnaeus), 287.
 tentaculatus (Rüppel), 286.
- Tibicininae, 36.
 Tic-wee buzzard, migration of, 199.
 Tineidæ, 165, 180.
Totanus eurhinus (Oberholser), 106.
Tortrix insulana Bois., 170.
Toxotes jaculatrix (Pallas), 282.
 Toxotidæ, 282.
- Transference, successful, of black bass into the Philippine Islands, 153.
 Transportation of live fish long distances, 153.
- Treronidæ, 105.
 Triacanthidæ, 284.
Triacanthus blochi Bleeker, 284.
 Trichiuridæ, 272.
Trichiurus haumela (Forskål), 272.
Tridacna gigas Linn., 98.
 Trifinæ, 171.
Trimerisurus halieus Griffin, 214.
 Trogonidæ, 110.
 Turdidæ, 112.
Tylosurus anulatus (Cuv. and Val.), 267.
 strongylurus (Kuhl and Van Hasselt), 267.
- Types, Filipino: The Women, 1.

U

- Umbrina russelli Cuv. and Val., 279.
 Upeneoides luzonius (Jordan and Seale),
 279.
 sulphureus (Cuv. and Val.), 279.
 tragula (Richardson), 278.
 vittatus (Forskål), 278.
 Urasse-fishes, Borneo, 281.
 Uroloncha everetti (Tweeddale), 113.
 Uxantis, 47.
 conspua Stål, 47.
 siccifolia Stål, 47.

V

- Verania nigrilabris Muls., 148.
 VIEHMEYER, H., On the Myrmecophily of
 Caterpillars of Catochrysops Cnejus Fabr.,
 69; A Myrmecophilous Lycaenid Chrysa-
 lls from the Philippines, 73.
 Vollenhovia banksi Forel, 126.
 oblonga Sm., subsp. *dispar*, 125.

W

- WEISE, J., Ueber Chrysmeliden und Coc-
 cinelliden Der Philippinen, 223; Ver-
 zeichniss von Coleopteren aus den Phil-
 ippinen, nebst zwei neuen Arten aus
 Niederländisch Ostindien, 139.
 Women, Filipino, 1.

X

- Xeocephus rufus (Gray), 111.
 Xystæma abbreviatus (Bleeker), 278.
 kapas (Bleeker), 278.
 lucidus (Cuv. and Val.), 278.
 oyena (Forskål), 278.
 punctatum (Cuv. and Val.), 277.

Y

- Yungipicus validirostris Blyth, 136, 220,
 221.

Z

- Zamila, 41.
 lycoides Walk., 41.
 perpusilla Dist., 41.
 Zamboanga pearling fleet, 89.
 Zenarchopterus buffonis Cuv. and Val., 267.
 dux Seale, 267.
 Zizera, 166.
 gaika Butl., 166.
 gaika Trim., 166.
 mora Swinh., 166.
 putli Semper, 166.
 Zoraida, 40.
 javanica Westw., 40.
 sinuosa Westw., 40.
 Zosterops batanis McGregor, 219.
 whiteheadi Hartert?, 138.
 Zosterornis whiteheadi Grant, 137, 138.



JUST ISSUED.

Order No. 412.

THE SUGAR INDUSTRY IN THE ISLAND OF NEGROS

By HERBERT S. WALKER.

145 pages, 10 photographic plates, and 1 map.

Price \$1.25, United States currency, postpaid.

CONTENTS.

	Page.
Introduction	9
General information regarding Negros	10
Geographical location	10
Size, shape, and area	10
Mountains	11
Rivers	11
Climate	11
The sugar belt.....	14
The east coast.....	15
Other sugar-producing districts of Negros.....	15
History of sugar production in Negros.....	16
Recent statistics	16
Varieties of cane grown in Negros.....	18
Cane diseases and insect enemies.....	19
Nationality of the planters.....	19
Native labor: Difficulties, past and present.....	20
The principal sugar-producing districts of Negros.....	22
Silay	22
Bago	27
Pontevedra-La Carlota	37
Binalbagan-Isabela	43
Ilog-Cabancalan	49
San Carlos	55
Bais	64
The soil of Negros compared with that of other sugar-producing countries....	68
Average composition of the soils of Negros.....	68
Hawaiian soils	70
Egyptian soils	70
Louisiana soils.....	71
Java soils	71
Demerara soils.....	71
Berbice soils	72
Mauritius soils.....	72
Comparison of Negros soils with those of other countries.....	72
Fertilization in Negros.....	73

[OVER.]

	Page.
The cane of Negros.....	76
Average composition of the purple or native sugar cane in Negros.....	76
Other varieties of cane grown in Negros.....	77
Cane in the Hawaiian Islands.....	79
Egyptian cane.....	80
Java cane.....	80
Louisiana cane.....	80
West Indian cane.....	81
Negros as compared with other countries in respect to the quality of cane.....	81
Desirability of introducing other varieties of cane.....	81
The cultivation of sugar cane and the production of sugar as carried on at the present time in Negros.....	82
Preparation of the soil.....	82
Preparation of the seed.....	83
Planting.....	83
Cultural operations after planting.....	84
Cultivation of ratoon canes.....	85
Period of growth of the cane.....	86
Cost of cultivation.....	87
Cutting the cane.....	90
Transporting the cane to the mill.....	91
Cost of cutting the cane and transporting it to the mill.....	92
Manufacture of sugar from the cane.....	92
Extraction of the juice.....	92
Manufacture of sugar from the juice.....	99
Quality of the sugar produced in Negros.....	109
Cost of manufacture.....	112
Transportation and sale of the sugar.....	113
Estimate of average cost of same.....	114
Quantitative experiments to determine the weight of sugar produced from a given weight of cane.....	114
Mill Control No. 1, hacienda San Jose.....	117
Mill Control No. 2, hacienda San Jose.....	118
Calculation of the average cost of producing sugar in Negros by the methods now employed.....	123
Cost for labor alone.....	123
Estimate of fixed charges for maintenance and depreciation of plant and interest on the capital invested.....	125
Total cost of production.....	126
Possibilities for improvement.....	126
In cultivation.....	126
In manufacture.....	127
Advantages of a change to modern methods of manufacture.....	132
The future of Negros.....	133
Summary.....	134
Appendix.....	139
An investigation to discover if diseases of the sugar cane exist in Negros.....	139
Index.....	143

NOTE.

Orders should be sent to the Business Manager, Philippine Journal of Science, Manila, or to any of the below-listed agents. *Please give Order Number.*

FOREIGN AGENTS.

The Macmillan Company, 64-66 Fifth Avenue, New York City, U. S. A.
 Messrs. Wm. Wesley & Son, 28 Essex Street, Strand, London, W. C., England.
 Mr. Martinus Nijhoff, Nobelstraat 18, The Hague, Holland.
 Messrs. Mayer & Muller, Prinz Louis Ferdinandstrasse 2, Berlin, N. W., Germany.
 Messrs. Kelley & Walsh, Limited, 32 Raffles Place, Singapore, Straits Settlements.
 Messrs. A. M. & J. Ferguson, 10 Baillie Street, Colombo, Ceylon.

CIRCULARS AND DESCRIPTIVE MATTER SENT ON APPLICATION.

INDO-MALAYAN WOODS

BY

FRED W. FOXWORTHY.

ORDER No. 411

(Being Section C, No. 4, Vol. IV, of the Philippine Journal of Science.)

182 PAGES.

9 PHOTOGRAPHIC PLATES.

Price \$0.50, U. S. currency—Postpaid.

TABLE OF CONTENTS.

- I. Introduction.
 - a. Erroneous popular notions with regard to eastern timbers.
 - b. Object of this work.
 - c. Definition of the Indo-Malayan region.
 - d. Review of previous work and acknowledgments.
- II. Properties of Wood.
 - a. Woods of Tropics and Temperate regions compared.
 - b. Weight and hardness, tables.
 - c. Strength, work of Newton, Gamble and Gardner.
 - d. Odor, color, taste.
- III. Suitability of different woods for special purposes.
 - a. Enemies of wood.
 - b. Woods exposed to salt water.
 - c. Ship and boat building.
- IV. Rare, ornamental, or precious woods.
- V. Comparative chart of common names.
- VI. Timbered areas and future supplies of wood.
- VII. Species notes.
- VIII. Index.

This valuable work is interesting both from the standpoint of commercial and scientific importance. As will be seen from the Table of Contents, the work treats exhaustively of the known Indo-Malayan woods.

NOTE.

Orders should be sent to the Business Manager, Philippine Journal of Science, Manila, or to any of the below-listed agents. *Please give Order Number.*

FOREIGN AGENTS.

The Macmillan Company, 64-66 Fifth Avenue, New York City, U. S. A.
Messrs. Wm. Wesley & Son, 28 Essex Street, Strand, London, W. C., England.
Mr. Martinus Nijhoff, Nobelstrant 18, The Hague, Holland.
Messrs. Mayer & Muller, Prinz Louis Ferdinandstrasse 2, Berlin, N. W., Germany.
Messrs. Kelley & Walsh, Limited, 32 Raffles Place, Singapore, Straits Settlements.
Messrs. A. M. & J. Ferguson, 19 Baillie Street, Colombo, Ceylon.

CIRCULARS AND DESCRIPTIVE MATTER SENT ON APPLICATION.

Order No. 407.

**THE BATAN DIALECT AS A MEMBER OF THE PHILIPPINE GROUP
OF LANGUAGES.**

By OTTO SCHEERER.

TOGETHER WITH

"F" AND "V" IN PHILIPPINE LANGUAGES.

By CARLOS EVERETT CONANT.

141 pages.

Price \$0.80 United States currency.

Order No. 408.

**A VOCABULARY OF THE IGOROT LANGUAGE AS SPOKEN BY THE
BONTOC IGOROTS.**

By the Rev. WALTER CLAYTON CLAPP.

Igorot-English and English-Igorot.

Price \$0.75 United States currency.

Order No. 102.

A MANUAL OF PHILIPPINE BIRDS.

By RICHARD MCGREGOR.

Part I.—412 pages }
Part II.—324 pages } In two volumes.

Descriptions of all known species of Philippine birds, together with
keys to species and genera.

Price (for the two volumes) \$4 United States currency, postpaid.

NOTE.

Orders should be sent to the Business Manager, Philippine Journal of Science, Manila,
or to any of the below-listed agents. *Please give Order Number.*

FOREIGN AGENTS.

The Macmillan Company, 64-66 Fifth Avenue, New York City, U. S. A.
Messrs. Wm. Wesley & Son, 23 Essex Street, Strand, London, W. C., England.
Mr. Martinus Nijhoff, Nobelstraat 18, The Hague, Holland.
Messrs. Mayer & Muller, Prinz Louis Ferdinandstrasse 2, Berlin, N. W., Germany.
Messrs. Kelley & Walsh, Limited, 32 Raffles Place, Singapore, Straits Settlements.
Messrs. A. M. & J. Ferguson, 19 Baillie Street, Colombo, Ceylon.

CIRCULARS AND DESCRIPTIVE MATTER SENT ON APPLICATION.

Order No. 401.

THE BONTOC IGOROT.

By A. E. JENKS.

110 pages. 3 maps. 154 photographic plates. 9 figures.

An interesting study; the result of almost a year's residence among the Bontoc Igorots.

Price \$1 United States currency, postpaid.

Order No. 402.

NEGRITOS OF ZAMBALES.

By WILLIAM ALLAN REED.

62 photographic illustrations. 91 pages.

An interesting ethnological study of the pygmy blacks of Zambales.

Price \$0.25, United States currency, postpaid.

Order No. 403.

THE NABALOI DIALECT.

By OTTO SCHEERER.

TOGETHER WITH

THE BATAKS OF PALAWAN.

By EDWARD Y. MILLER.

199 pages. 1 map. 28 full-page photographic plates. 6 figures.

The result of research work among this interesting tribe of primitive people.

Price \$0.25, United States currency, paper, postpaid.

NOTE.

Orders should be sent to the Business Manager, Philippine Journal of Science, Manila, or to any of the below-listed agents. *Please give Order Number.*

FOREIGN AGENTS.

The Macmillan Company, 64-66 Fifth Avenue, New York City, U. S. A.
Messrs. Wm. Wesley & Son, 25 Essex Street, Strand, London, W. C., England.
Mr. Martinus Nijhoff, Nobelstraat 15, The Hague, Holland.
Messrs. Mayer & Müller, Prinz Louis Ferdinandstrasse 2, Berlin, N. W., Germany.
Messrs. Kelley & Walsh, Limited, 32 Raffles Place, Singapore, Straits Settlements.
Messrs. A. M. & J. Ferguson, 19 Baillie Street, Colombo, Ceylon.

CIRCULARS AND DESCRIPTIVE MATTER SENT ON APPLICATION.

Beginning with Volume V, a new section, "Section D, Ethnology, Anthropology, and General Biology," will be added to the Journal. The price for the whole series to subscribers for 1910 will be as heretofore, \$5 United States currency. Single subscriptions to Section D will be \$2 United States currency.

Beginning with 1911, the price of the entire Journal will be increased to \$7 United States currency. Section D will appear as often as material is available.

CONTENTS.

	Page.
GRIFFIN, LAWRENCE E. <i>Euplotes Worcesteri</i> sp. nov.: II. Division.....	315
REVIEW.....	337
Index, Title-page and Contents.....	339

The "Philippine Journal of Science" is issued as follows:

Section A, Chemical and Geological Sciences and the Industries, \$2 United States currency per year.

Section B, Medical Sciences, \$3 United States currency per year.

Section C, Botany, \$2 United States currency per year.

Section D, Ethnology, Anthropology, and General Biology, \$2 United States currency per year.

The entire "Journal," \$5 United States currency for Volumes II, III, IV, and V. Thereafter, \$7 United States currency per year.

Authors receive 100 copies of their papers free.

Subscriptions should be sent to the Business Manager, Philippine Journal of Science, Bureau of Science, Manila, P. I., or to any of the agents listed below. Please give order number.

FOREIGN AGENTS.

The Macmillan Company, 64-66 Fifth Avenue, New York City, U. S. A.

Messrs. Wm. Wesley & Son, 28 Essex Street, Strand, London, W. C., England.

Mr. Martinus Nijhoff, Nobelstraat 18, The Hague, Holland.

Messrs. Mayer & Muller, Prinz Louis Ferdinandstrasse 2, Berlin, N. W., Germany.

Messrs. Kelley & Walsh, Limited, 32 Raffles Place, Singapore, Straits Settlements.

Messrs. A. M. & J. Ferguson, 19 Baillie Street, Colombo, Ceylon.

Entered at the post-office at Manila, P. I., as second-class matter.

A limited number of unbound copies of previous volumes are available, which may be secured from the Business Manager, Philippine Journal of Science, Manila, P. I., at the following rates: Volume I, 1906 (not divided into sections), \$10 United States currency; Supplement to Volume I, \$3.50 United States currency; Volume I (without supplement), \$6.50 United States currency; all later volumes at current subscription prices.

7746



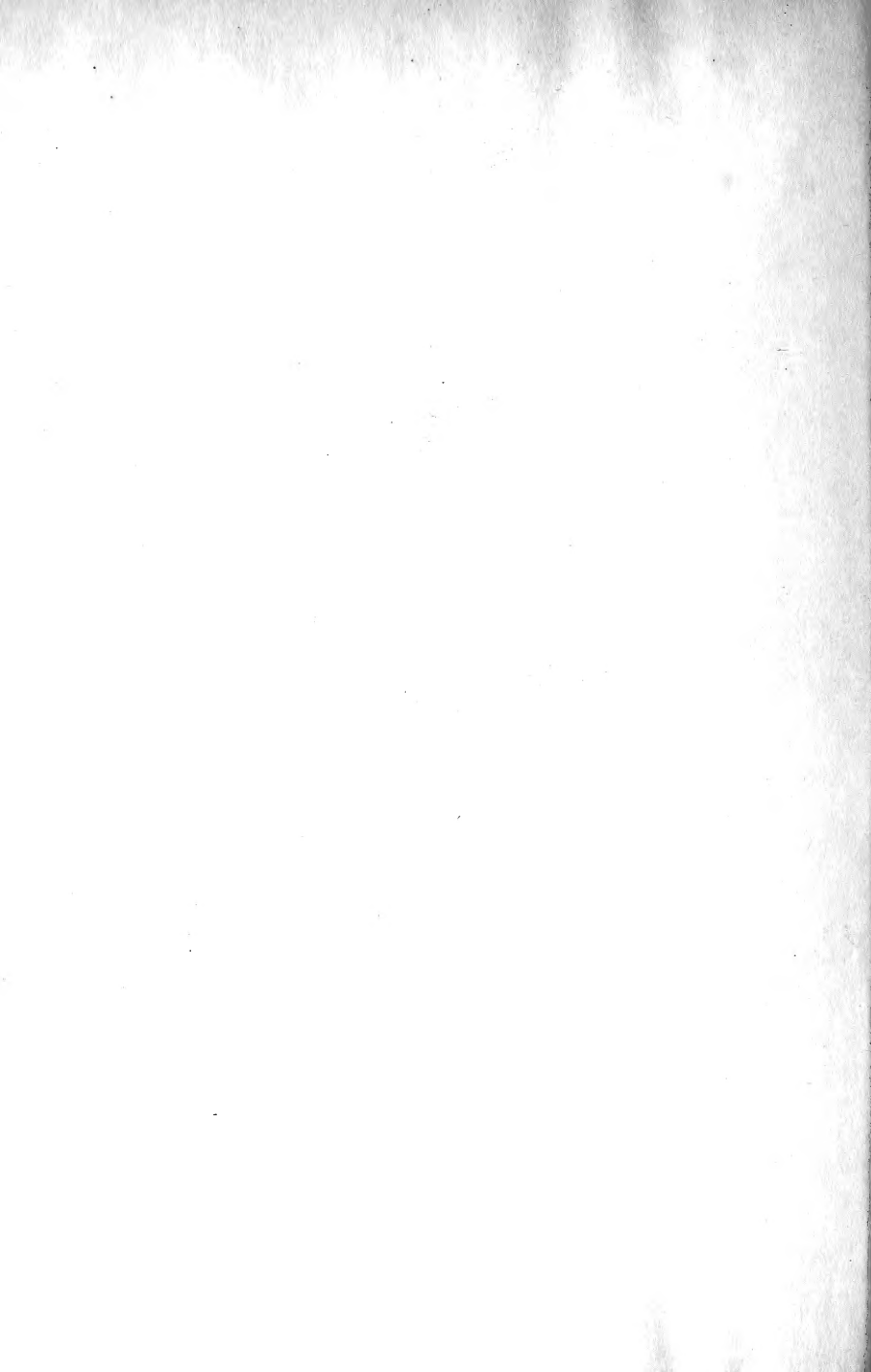

SMITHSONIAN INSTITUTION LIBRARIES



3 9088 01307 6708