

L. R. 1.

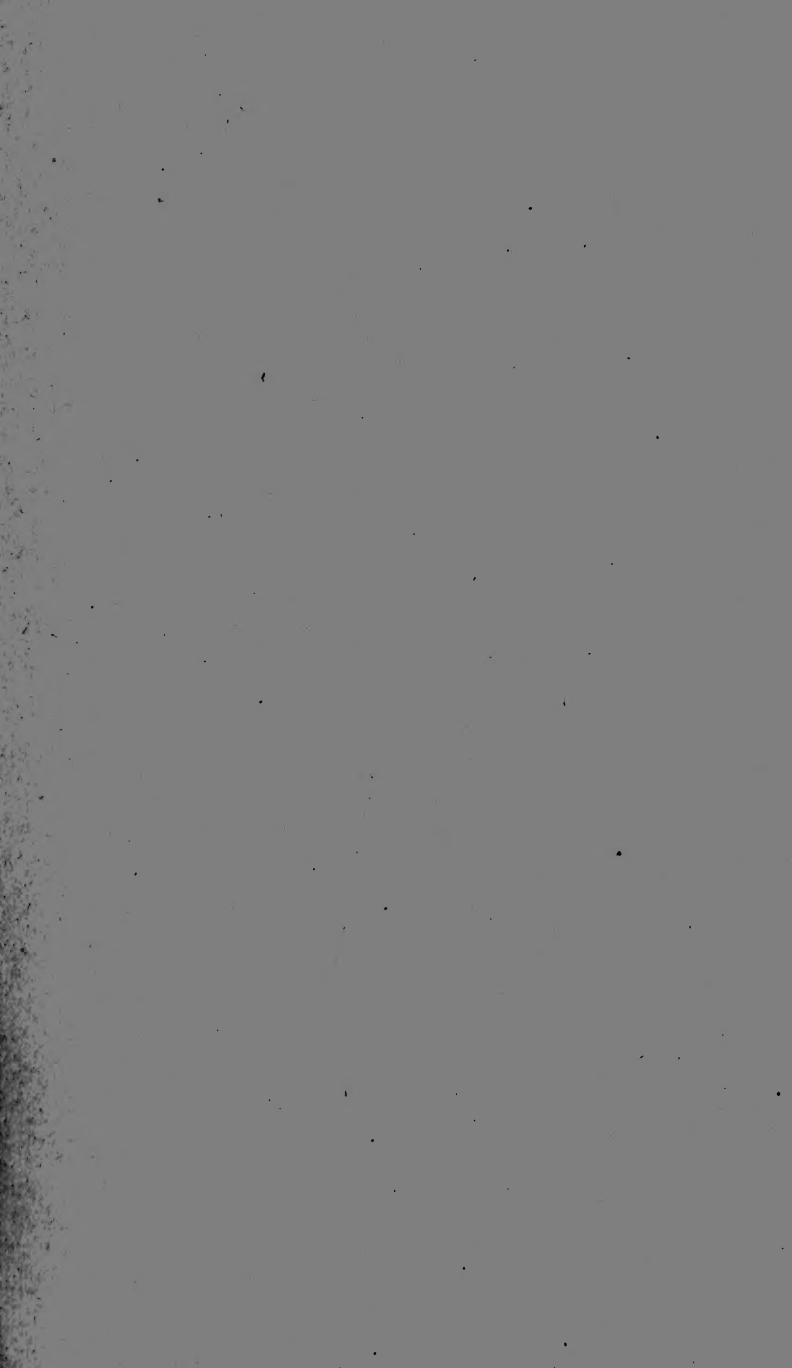

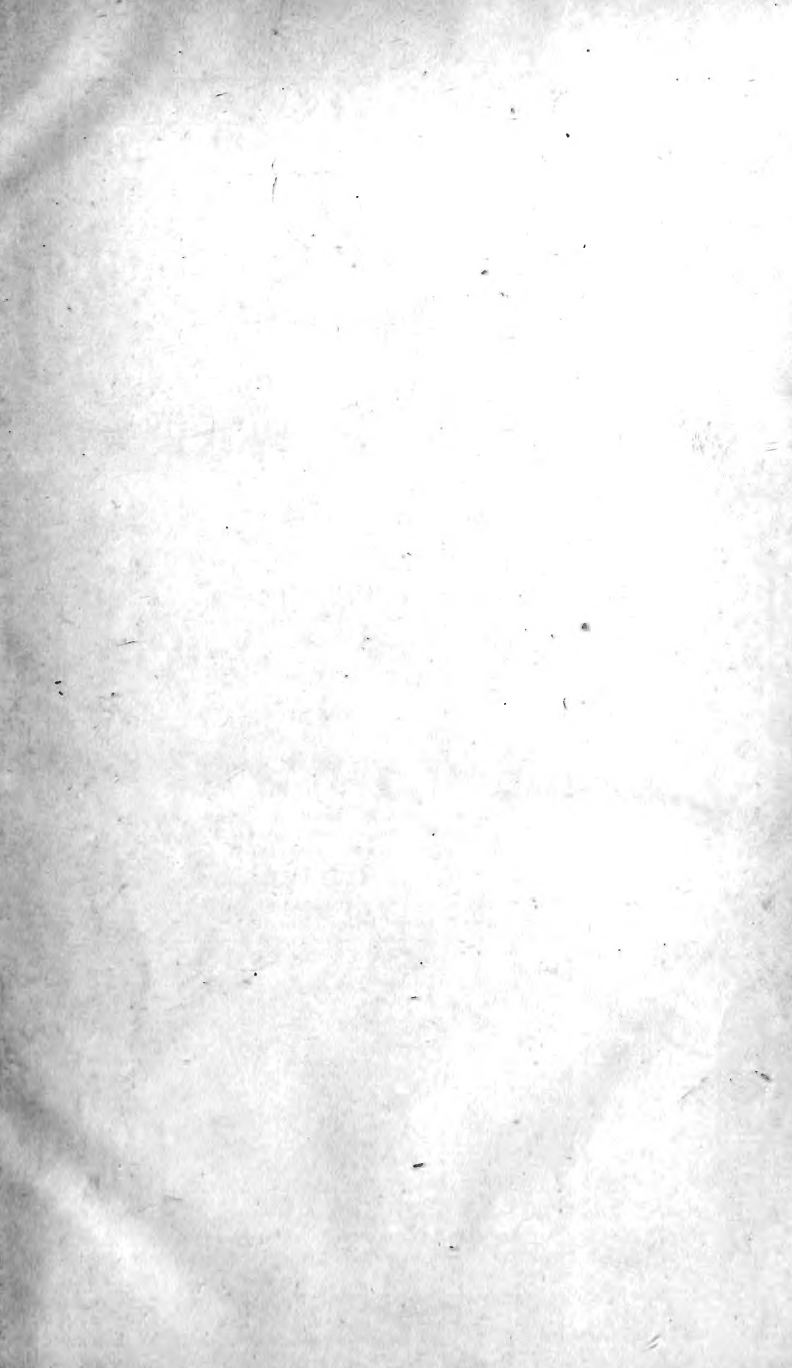



Faint handwritten text at the top of the page, possibly including a name and a date.

75

A faint horizontal line or scribble across the middle of the page.

Published the Last Day of every Month.—Price 2s. 6d.

THE
**PHILOSOPHICAL MAGAZINE
 AND JOURNAL:**

COMPREHENDING
 THE VARIOUS BRANCHES OF SCIENCE,
 THE LIBERAL AND FINE ARTS,
 AGRICULTURE, MANUFACTURES,
 AND COMMERCE.

NUMBER CCCXV.

For JULY 1824.

WITH A PLATE

Illustrative of Mr S. SEAWARD'S Hydro-Pneumatic Pump for
 compressing Gases.

By *ALEXANDER TILLOCH, LL.D.*

M.R.L.A. F.S.A. EDIN. AND PERTH; CORRESPONDING MEMBER OF THE ROYAL
 ACADEMY OF SCIENCES, MUNICH; AND OF THE ACADEMY OF SCIENCES,
 LITERATURE AND ARTS, LEGHORN, ETC.

AND *RICHARD TAYLOR, F.L.S.*

MEMBER OF THE ASTRONOMICAL SOCIETY OF LONDON, AND OF THE ASIATIC SOCIETY
 OF GREAT BRITAIN AND IRELAND.



LONDON:

PRINTED BY RICHARD TAYLOR, SHOE-LANE:

Sold by Cadell; Longman, Hurst, Rees, Orme, Brown and Green; Baldwin,
 Cradock, and Joy; Hightley; Sherwood, Jones, and Co.; Harding; Under-
 wood; Simpkin and Marshall; London:—and by Constable and Co. Edin-
 burgh; and Penman, Glasgow.

This day is published, in one very large and closely printed Volume, 8vo,
Price 18s. boards,

THE PERENNIAL CALENDAR, and COMPANION to the ALMANACK; illustrating the Events of every Day in the Year, as connected with History, Chronology, Botany, Natural History, Astronomy, Popular Customs, and Antiquities; with Useful Rules of Health, Observations on the Weather, an Explanation of the Fasts and Festivals of the Church, and other Miscellaneous Useful Information.

By THOMAS FORSTER, F.L.S. M.B. &c. &c. Fellow of C. C. College, Cambridge.

Also, by the same Author,

A TREATISE on ATMOSPHERIC PHENOMENA, as affecting the Weather. Third Edition, One Volume, 8vo, Six Plates, 15s. boards.

Printed for Harding, Triphook, and Lepard, London.

In One Volume 8vo, with Coloured Figures of *Camellia Japonica*,
price 14s. boards,

THE GREEN-HOUSE COMPANION; comprising a general Course of Green-House and Conservatory Management throughout the year; a descriptive selection of the most desirable Plants to form a Collection, with familiar instructions for their culture and propagation; the proper treatment for Plants in Rooms, and of Bulbs in Water Glasses. Also Plans for the construction of Green-Houses and Conservatories; and the Green-House Catalogue, containing a Botanical Arrangement of all the Green-House Plants in cultivation, with their proper soils, modes of propagation, and references to Botanical Works in which they are figured; with other particulars.

London: Printed for Harding, Triphook, and Lepard, Finsbury Square; and John Harding, St. James's Street.

PHARMACOPŒIA LONDINENSIS,

Iterum recognita et retractata, 1824, p. 6.

“*ACIDUM ACETICUM FORTIUS*,”

vel

“*Acidum Aceticum è Ligno destillatum.*”

PURE CONCENTRATED ACETIC ACID, agreeable to the Sample furnished at the request of the Committee of the Royal College of Physicians, may be had of the Manufacturers, BEAUFOY & CO. South Lambeth, London.

This day is published, No. II., price 10s. of

THE ZOOLOGICAL JOURNAL, to be continued Quarterly; conducted

By THOMAS BELL, Esq., F.L.S. JOHN GEORGE CHILDREN, Esq. F.R. and L.S. JAMES DE CARLE SOWERBY, Esq., F.L.S. and G. B. SOWERBY, F.L.S.

Printed and published by W. Phillips, George Yard, Lombard Street. Sold also by G. B. Sowerby, 156, Regent Street; where communications are to be addressed; W. and C. Tait, Edinburgh; and A. A. Royer, au Jardin des Plantes, à Paris.

Published the Last Day of every Month.—Price 2s. 6d.

THE
**PHILOSOPHICAL MAGAZINE
 AND JOURNAL:**

COMPREHENDING

THE VARIOUS BRANCHES OF SCIENCE,
 THE LIBERAL AND FINE ARTS,
 AGRICULTURE, MANUFACTURES,
 AND COMMERCE.

NUMBER CCCXVI.

For AUGUST 1824.

BY ALEXANDER TILLOCH, LL.D.

M.R.I.A. F.S.A. EDIN. AND PERTH; CORRESPONDING MEMBER OF THE ROYAL
 ACADEMY OF SCIENCES, MUNICH; AND OF THE ACADEMY OF SCIENCES,
 LITERATURE AND ARTS, LECHORN, ETC.

AND RICHARD TAYLOR, F.L.S.

MEMBER OF THE ASTRONOMICAL SOCIETY OF LONDON; OF THE METEORO-
 LOGICAL SOCIETY; AND OF THE ROYAL ASIATIC SOCIETY
 OF GREAT BRITAIN AND IRELAND.



LONDON:

PRINTED BY RICHARD TAYLOR, SHOE-LANE:

Sold by Cadell; Longman, Hurst, Rees, Orme, Brown and Green; Baldwin,
 Cradock, and Joy; Highley; Sherwood, Jones, and Co.; Harding; Under-
 wood; Simpkin and Marshall; London:—and by Constable and Co. Edin-
 burgh; and Penman, Glasgow.

TO CORRESPONDENTS.

The following communications have been received :

Mr. FAREY on the Velocity of Sound.

Mr. WALSH on the 12th Book of Euclid.

Mr. W. GALBRAITH on the Experiments on the Pendulum made by Captain KATER, &c.

We must beg the indulgence of XX, who shall hear from us immediately.

PETER NICHOLSON'S ARCHITECTURAL DICTIONARY. COURT OF CHANCERY.

THE Public having long heard of Mr. BARFIELD'S Application to the Court of Chancery to restrain Mr. KELLY from publishing any Work of Nicholson's on the Subject of Architecture, are respectfully informed, that he has at length obtained an Order from the LORD CHANCELLOR in the following Words :

“ On July 27, 1824, it was ordered, That an INJUNCTION be awarded to restrain the Defendant, Thomas Kelly, his Agents, &c. from publishing, or selling, in the Name of Peter Nicholson, the Book or Work, in the Pleadings mentioned, called *The Practical Builder*, or any Parts or Part, or Numbers or Number thereof, and also from employing the Defendant, Peter Nicholson, from writing any Part of the Letter-press, or Designing any of the Plates of the said Book or Work, called *The Practical Builder*; and that the said Defendant, Thomas Kelly, be also restrained from publishing or selling, in the Name of Peter Nicholson, any Part of the said Book, or Work, called *The Practical Builder*, printed or engraved since the Filing of the Plaintiff's Bill in this Cause, which has been written or designed by the Defendant, Peter Nicholson, until the Hearing of this Cause, or until the further Order of the Court.”

NICHOLSON'S ARCHITECTURAL DICTIONARY, and BUILDERS', CARPENTERS', and JOINERS' COMPLETE WORK BOOK, is now Publishing in Weekly Numbers, at One Shilling each. Every Number will contain at least One Sheet of closely printed Letter-press, printed in an elegant Manner on fine Yellow-wove Paper, Hot-pressed, and One or Two Copper-plate Engravings.

The Work being already complete, may be had in Thirty-five Parts, at Six Shillings each; five Copies Ten Shillings each, or Bound in Two handsome Volumes.

Persons wishing to possess A GENUINE WORK, will find the ARCHITECTURAL DICTIONARY the completest on Architecture and practical Building ever published.

London: Printed and Sold by J. Barfield, 91, Wardour-street, Soho; Sold also by Sherwood and Co. Paternoster-row, and by all Booksellers in Town and Country.

Published the Last Day of every Month.—Price 2s. 6d.

THE
**PHILOSOPHICAL MAGAZINE
 AND JOURNAL:**

COMPREHENDING

THE VARIOUS BRANCHES OF SCIENCE,
 THE LIBERAL AND FINE ARTS,
 AGRICULTURE, MANUFACTURES,
 AND COMMERCE.

NUMBER CCCXVII.

For SEPTEMBER 1824.

By ALEXANDER TILLOCH, LL.D.

MR.L.A. F.S.A. EDIN. AND PERTH; CORRESPONDING MEMBER OF THE ROYAL
 ACADEMY OF SCIENCES, MUNICH; AND OF THE ACADEMY OF SCIENCES,
 LITERATURE AND ARTS, LEGHORN, ETC.

AND RICHARD TAYLOR, F.L.S.

MEMBER OF THE ASTRONOMICAL SOCIETY OF LONDON; OF THE METEOROLOGICAL
 SOCIETY; AND OF THE ROYAL ASIATIC SOCIETY
 OF GREAT BRITAIN AND IRELAND.



LONDON:

PRINTED BY RICHARD TAYLOR, SHOE-LANE:

Sold by Cadell; Longman, Hurst, Rees, Orme, Brown and Green; Baldwin,
 Cradock, and Joy; Highley; Sherwood, Jones, and Co.; Harding; Under-
 wood; Simpkin and Marshall; London:—and by Constable and Co. Edin-
 burgh; and Penman, Glasgow.

TO CORRESPONDENTS.

In our next Number we shall insert Mr. STURGEON'S Communication on Electro-Magnetism, and the Continuation of Mr. BRAYLEY'S Paper respecting Meteors and Meteorites.

We shall have much pleasure in communicating Mr. VEALL'S Suggestion to the Meteorological Society.

Communications from Mr. EVANS on Sir Isaac NEWTON'S Binomial Theorem; Mr. TATUM on a Rain Gauge; Mr. PAUL NEWTON on the Duplication of the Cube; and C. on the Secular Change of the Obliquity of the Ecliptic, have been received.

We have hesitated respecting the insertion of Mr. UTTING'S Paper on an Analogy which obtains between the Projectile and Gravitating Forces in the Planetary System; as this analogy is an obvious result of KEPLER'S LAWS, and as we have incurred more expense in the printing of Astronomical Tables than we can well bear.

The subject of Mr. DORODEN'S Letter, for which we are much obliged to him, engages at present our serious attention.

We have received at a very late period of the month a Communication from Mr. SAMUEL SEAWARD, on his Claim to the Invention of the Hydro-pneumatic Pump figured and described by him in our present volume. We must refer this gentleman to our repeatedly declared resolution not to suffer our pages to be occupied by private controversies, or to be the vehicle of personal asperities, as our reason for declining to insert his letter. All that we can be expected to state is, that it contains a re-assertion that he is the inventor of the pump in question; but we should not wish to have our Journal made a medium for the discussion of private claims of this kind, even if any evidence had been offered.

PHARMACOPŒIA LONDINENSIS,

Iterum recognita et retractata, 1824, p. 6.

“*ACIDUM ACETICUM FORTIUS,*”

vel

“*Acidum Aceticum è Ligno destillatum.*”

PURE CONCENTRATED ACETIC ACID, agreeable to the Sample furnished at the request of the Committee of the Royal College of Physicians, may be had of the Manufacturers, BEAUFOY & CO. South Lambeth, London.

ENGRAVINGS.

Vol. LVI. A Plate illustrative of Mrs. IBBETSON'S Paper On the Physiology of Botany.—A Plate illustrative of Mr. HALL'S Percussion Gun-Lock; of Dr. KITCHINER'S Pancreatic Eye-Tube; and of Mr. PARK'S Mooring Blocks.—A Plate exhibiting Sections, &c. of Mr. MALAM'S improved Gas-Meter.—A Plate exhibiting the Discoveries made by Capt. PARRY in the Polar Sea.

Published the Last Day of every Month.—Price 2s. 6d.

THE
PHILOSOPHICAL MAGAZINE
 AND JOURNAL:

COMPREHENDING
 THE VARIOUS BRANCHES OF SCIENCE,
 THE LIBERAL AND FINE ARTS,
 AGRICULTURE, MANUFACTURES,
 AND COMMERCE.

NUMBER CCCXVIII.

For OCTOBER 1824.

WITH A PLATE

Illustrative of Mr. STURGEON'S Electro-Magnetic Rotating Apparatus; and of Mr. HAYCRAFT'S Apparatus for ascertaining the Specific Heat of Gases.

By ALEXANDER TILLOCH, LL.D.

M.R.L.A. F.S.A. EDIN. AND PERTH; CORRESPONDING MEMBER OF THE ROYAL ACADEMY OF SCIENCES, MUNICH; AND OF THE ACADEMY OF SCIENCES, LITERATURE AND ARTS, LEGHORN, ETC.

AND RICHARD TAYLOR, F.L.S.

MEMBER OF THE ASTRONOMICAL SOCIETY OF LONDON; OF THE METEOROLOGICAL SOCIETY; AND OF THE ROYAL ASIATIC SOCIETY OF GREAT BRITAIN AND IRELAND.



LONDON:

PRINTED BY RICHARD TAYLOR, SHOE-LANE:

Sold by Cadell; Longman, Hurst, Rees, Orme, Brown and Green; Baldwin, Cradock, and Joy; Highley; Sherwood, Jones, and Co.; Harding; Underwood; Simpkin and Marshall; London:—and by Constable and Co. Edinburgh; and Penman, Glasgow.

TO CORRESPONDENTS.

The following Communications have been received :

Mr. W. HERAPATH's Contributions to the Knowledge of Chemical Bodies. Meteorological Register kept at Wick in North Britain.

Mr. CERCOVE on a Bullet of a new Construction.

Mr. WALSH's Paper on the Calculus of Variations; and Mr. SMITH's on the Mean Solar Time, will appear in our next.

Published by Longman and Co. Paternoster Row, and Taylor, High Holborn, in One Volume Royal 8vo, illustrated with Six Plates.

AN INQUIRY INTO THE ORIGIN AND INFLUENCE OF GOTHIC ARCHITECTURE,

By WILLIAM GUNN, B.D. Rector of Irstead, Norfolk.

Notes on the following Subjects are subjoined to the work :

On the interior Decoration and Arrangement of Churches in ancient Times.

On the various Kinds of Marble, &c. employed in the Architecture of ancient Rome, and the Time of their Introduction.

On the Antiquity of the Arch, and particularly of the Cloaca Maxima.

Of the Intercourse between Men of Learning and Artists in Rome and Constantinople, from the Reign of Justinian to the First Crusade.

On the ancient Rituals, with additional Remarks on the interior Arrangement of Churches.

This day is published, No. III. of

THE ZOOLOGICAL JOURNAL, to be continued Quarterly ; conducted

By THOMAS BELL, Esq., F.L.S. JOHN GEORGE CHILDREN,
Esq. F.R. and L.S. JAMES DE CARLE SOWERBY, Esq., F.L.S.
and G. B. SOWERBY, F.L.S.

London : Printed and published by W. Phillips, George Yard, Lombard-Street. Sold also by G. B. Sowerby, 156, Regent Street ; to whom communications are to be addressed ; W. and C. Tait, Edinburgh : and A. A. Royer, au Jardin des Plantes, à Paris.

This Day is published, in Demy 8vo, price 12s. in boards,

AN ESSAY ON INSTINCT; and its PHYSICAL and MORAL RE- LATIONS. By THOMAS HANCOCK, M.D.

For Reason raise o'er Instinct, as you can ;

In this 'tis God directs, in that 'tis man.—POPE.

A man's nature runs either to herbs or weeds : therefore let him seasonably water the one, and destroy the other.—BACON.

London: Printed and published by William Phillips, George-yard, Lombard street; sold also by Hatchard and Son, Piccadilly; and by W. and C. Tait, Edinburgh.

PHARMACOPŒIA LONDINENSIS,

Iterum recognita et retractata, 1824, p. 6.

“ACIDUM ACETICUM FORTIUS,”

vel

“*Acidum Aceticum è Ligno destillatum.*”

PURE CONCENTRATED ACETIC ACID, agreeable to the Sample furnished at the request of the Committee of the Royal College of Physicians, may be had of the Manufacturers, BEAUFOY & CO. South Lambeth, London.

Published the Last Day of every Month.—Price 2s. 6d.

THE
**PHILOSOPHICAL MAGAZINE
 AND JOURNAL:**

COMPREHENDING
 THE VARIOUS BRANCHES OF SCIENCE,
 THE LIBERAL AND FINE ARTS,
 AGRICULTURE, MANUFACTURES,
 AND COMMERCE.

NUMBER CCCXIX.

For NOVEMBER 1824.

By *ALEXANDER TILLOCH, LL.D.*

M.B.A. F.S.A. EDIN. AND PERTH; CORRESPONDING MEMBER OF THE ROYAL
 ACADEMY OF SCIENCES, MUNICH; AND OF THE ACADEMY OF SCIENCES,
 LITERATURE AND ARTS, LEHORN, ETC.

AND *RICHARD TAYLOR, F.L.S.*

MEMBER OF THE ASTRONOMICAL SOCIETY OF LONDON; OF THE METEOROLOGICAL
 SOCIETY; AND OF THE ROYAL ASIATIC SOCIETY
 OF GREAT BRITAIN AND IRELAND.



LONDON:

PRINTED BY RICHARD TAYLOR, SHOE-LANE:

Sold by Cadell; Longman, Hurst, Rees, Orme, Brown and Green; Baldwin,
 Cradock, and Joy; Highley; Sherwood, Jones, and Co.; Harding; Under-
 wood; Simpkin and Marshall; London:—and by Constable and Co. Edin-
 burgh; and Pennan, Glasgow.

TO CORRESPONDENTS.

Mr. HAWORTH's Third Decade of New Succulent Plants has been received, and will appear in our next.

Mr. S. SEWARD will receive a Communication from us.

Mr. J. LINDLEY, on the Vegetable Physiology of *M. du Petit-Thouars*, in reply to Sir J. E. SMITH, will appear in our next Number.

Mr. BYWATER's Description of a New Vertical Joint for Reflecting Telescopes, has been received.

The following communications have also been received :

Mr. PAUL NEWTON on the Duplication of the Cube; and C. on the Solar Tables.

ERRATUM.—In each of the Tables, in page 297 of our preceding Number, for 21, 22, 23, 24 Min., and 21, 22, 23, 24 Sec., read 30, 40, 50, 60 Min. and 30, 40, 50, 60 Sec.

Shortly will be published, in 2 Vols. 8vo.

PHARMACOLOGIA, Edition the Sixth. Corrected, Extended, and Continued, in accordance with the new Pharmacopœia of 1824, and with the generally advanced state of Chemical Science.

By JOHN AYRTON PARIS, M.D. F.R.S. F.L.S.

Fellow of the Royal College of Physicians of London, &c. &c. &c.

In this Edition will be introduced a revolving scale, termed the MEDICINAL DYNAMETER, which is capable of showing on mere inspection the absolute and relative strength of the different Preparations of Medicine, the composition of which being, at the same time, exhibited by a combination of colours.

London: printed and published by William Phillips, George Yard, Lombard Street.

Shortly will be published, in 1 Vol. 8vo.

Illustrated by numerous Engravings on Wood,

THE ELEMENTS OF MEDICAL CHEMISTRY. Embracing only those branches of Chemical Science which are calculated to illustrate or explain the different objects of Medicine; and to furnish a Chemical Grammar to the Author's Pharmacologia.

By JOHN AYRTON PARIS, M.D. F.R.S. F.L.S.

Fellow of the Royal College of Physicians of London, &c.

"The objects of Science are so multiplied that it is high time to subdivide them. Thus the numerous branches of an overgrown family in the Patriarchal ages found it necessary to separate; and the convenience of the whole, and the strength and increase of each branch, were promoted by the separation."—PRIESTLEY.

London: printed and published by William Phillips, George Yard, Lombard Street.

A COMPANION TO ALL WORKS ON CHEMISTRY.

This day is published in 8vo, with seventeen quarto copperplates, price 16s. extra boards,

AN EXPLANATORY DICTIONARY of the APPARATUS and INSTRUMENTS employed in the various Operations of Philosophical and Experimental Chemistry.

By A PRACTICAL CHEMIST.

Printed for Thomas Boys, Ludgate Hill; and sold by Oliver and Boyd, Edinburgh, and all Booksellers.

Published the Last Day of every Month.—Price 2s. 6d.

THE
**PHILOSOPHICAL MAGAZINE
 AND JOURNAL:**

COMPREHENDING
 THE VARIOUS BRANCHES OF SCIENCE,
 THE LIBERAL AND FINE ARTS,
 AGRICULTURE, MANUFACTURES,
 AND COMMERCE.

NUMBER CCCXX.

For DECEMBER 1824.

WITH A PLATE

Illustrative of Fossil Remains of two new Saurian Animals found
 in America.

By *ALEXANDER TILLOCH, LL.D.*

M.R.S.A. F.S.A. EDIN. AND PERTH; CORRESPONDING MEMBER OF THE ROYAL
 ACADEMY OF SCIENCES, MUNICH; AND OF THE ACADEMY OF SCIENCES,
 LITERATURE AND ARTS, LEGHORN, ETC.

AND *RICHARD TAYLOR, F.L.S.*

MEMBER OF THE ASTRONOMICAL SOCIETY OF LONDON; OF THE METEOROLO-
 GICAL SOCIETY; AND OF THE ROYAL ASIATIC SOCIETY
 OF GREAT BRITAIN AND IRELAND.



LONDON:

PRINTED BY RICHARD TAYLOR, SHOE-LANE:

Sold by Cadell; Longman, Hurst, Rees, Orme, Brown and Green; Baldwin,
 Cradock, and Joy; Highley; Sherwood, Jones, and Co.; Harding; Under-
 wood; Simpkin and Marshall; London:—and by Constable and Co. Edin-
 burgh; and Penman, Glasgow.

TO CORRESPONDENTS.

We have to acknowledge the receipt of a Communication from Mr. GALBRAITH on Captain KATER's Experiments on the Pendulum: Also of one from Mr. MEIKLE on the Existence of distinct Calorific Rays in the Sun-beams.—We hope to insert in our next a Paper by Mr. SQUIRE on a Compensating Pendulum; and in the mean time take the liberty of directing his attention to the Observations on the use of Deal for Pendulum-rods, by Mr. BAILY, in his paper on Compensation Pendulums, in the Second Part of the Astronomical Society's Transactions lately published.—Mr. BUTTER's newly-published "Abstract of the Weights' and Measures' Act, with Tables comparing the Old and New Standard," has been received, and will be noticed in our next.

Published by Longman and Co. Paternoster Row, and Taylor, High Holborn, in One Volume Royal 8vo, illustrated with Six Plates.

AN INQUIRY INTO THE ORIGIN AND INFLUENCE OF GOTHIC ARCHITECTURE,

By WILLIAM GUNN, B.D. Rector of Irstead, Norfolk.

Notes on the following Subjects are subjoined to the work :

On the interior Decoration and Arrangement of Churches in ancient Times.

On the various Kinds of Marble, &c. employed in the Architecture of ancient Rome, and the Time of their Introduction.

On the Antiquity of the Arch, and particularly of the Cloaca Maxima. Of the Intercourse between Men of Learning and Artists in Rome and Constantinople, from the Reign of Justinian to the First Crusade.

On the ancient Rituals, with additional Remarks on the interior Arrangement of Churches.

This day is published, No. IV. Price 10s. coloured, or 7s. 6d. with the Plates uncoloured, of

THE ZOOLOGICAL JOURNAL, completing the 1st volume. In this volume are contained Communications from the following celebrated Zoologists:—H. De La Beche, Esq.; T. Bell, Esq.; Mr. E. G. Bennett; Broderip, Esq.; W. J. Burchell, Esq.; J. G. Children, Esq.; J. O. French, Esq.;—Mr. J. E. Gray; Dr. Horsfield; Rev. W. Kirby; Dr. Leach; W. S. MacLeay, Esq.; Mr. G. B. Sowerby; J. D. C. Sowerby, Esq.; Mr. Stephen; Mr. Such; W. Swainson, Esq.; N. A. Vigors, Jun. Esq.

London: Printed and published by W. Phillips, George Yard, Lombard-Street. Sold also by G. B. Sowerby, 156, Regent Street; to whom Communications are to be addressed; W. and C. Tait, Edinburgh; and A. A. Royer, au Jardin des Plantes, à Paris.

With No. V. will appear the first fasciculus of ILLUSTRATIONS OF THE ZOOLOGICAL JOURNAL, consisting of coloured Engravings of subjects described in that work.

This day is published in 4to., price 1l. 4s.

THE SECOND PART OF VOL. I. OF THE MEMOIRS OF THE ASTRONOMICAL SOCIETY OF LONDON.

Published by Baldwin, Cradock, and Joy, Paternoster Row; of whom may also be had Part I., price One Guinea.

* * * The Members of the Society may obtain their Copies (Part I. at 10s. 6d.; Part II. at 12s.), of Mr. Harrison, Collector to the Society, 41 Bedford Street, Covent Garden,

ZINE

ENCE,

'S,

URES,

=

L.D.

IG MEMBER OF
E-ACADEMY
TC.

L.S.

HE METEORO-
IETY

;

it, nec noster
b. i. cap. 1.



NOVEMBER,

NE :

N, AND GREEN ;
D, JONES,
AND

Fig. 3.

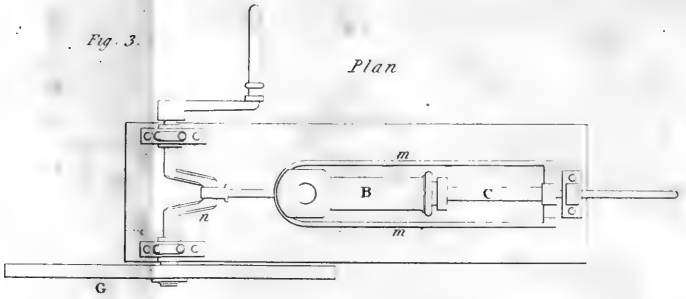
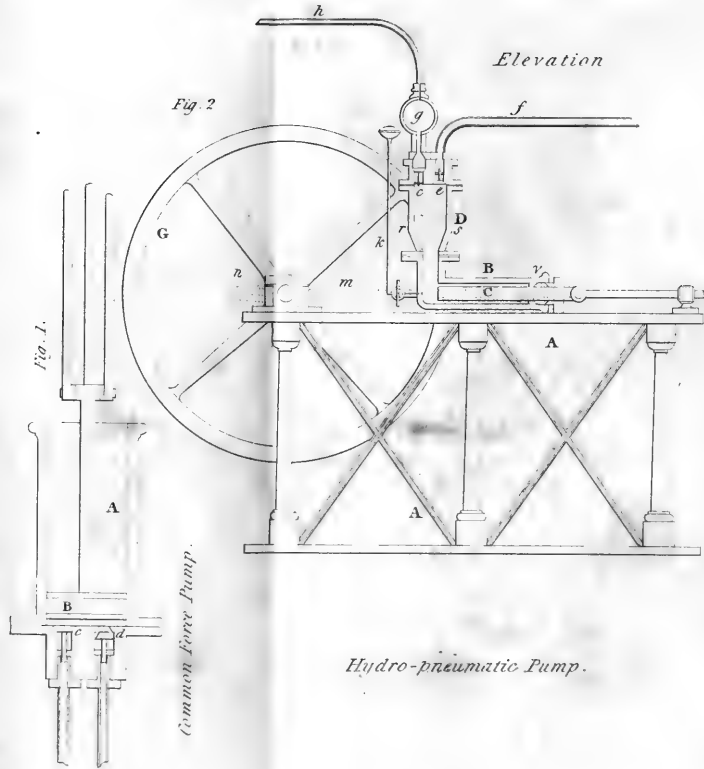

Fig. 2.

Elevation



Hydro-pneumatic Pump.

THE
PHILOSOPHICAL MAGAZINE
AND JOURNAL:

COMPREHENDING

THE VARIOUS BRANCHES OF SCIENCE,
THE LIBERAL AND FINE ARTS,
AGRICULTURE, MANUFACTURES,
AND COMMERCE.

By *ALEXANDER TILLOCH, LL.D.*

M.R.I.A. M.G.S. M.A.S. F.S.A. EDIN. AND PERTH; CORRESPONDING MEMBER OF
THE ROYAL ACADEMY OF SCIENCES, MUNICH; AND OF THE ACADEMY
OF SCIENCES, LITERATURE AND ARTS, LEGHORN, ETC.

AND *RICHARD TAYLOR, F.L.S.*

MEMBER OF THE ASTRONOMICAL SOCIETY OF LONDON, OF THE METEORO-
LOGICAL SOCIETY; AND OF THE ROYAL ASIATIC SOCIETY
OF GREAT BRITAIN AND IRELAND.

“Nec aranearum sane textus ideo melior quia ex se fila gignunt, nec noster
vilior quia ex alienis libamus ut apes.” *Jusr. Lips. Monit. Polit. lib. i. cap. 1.*

VOL. LXIV.

For *JULY, AUGUST, SEPTEMBER, OCTOBER, NOVEMBER,*
and *DECEMBER, 1824.*

LONDON:

PRINTED BY RICHARD TAYLOR, SHOE-LANE:

AND SOLD BY CADELL; LONGMAN, HURST, REES, ORME, BROWN, AND GREEN;
BALDWIN, CRADOCK, AND JOY; HIGHLEY; SHERWOOD, JONES,
AND CO.; HARDING; UNDERWOOD; SIMPKIN AND
MARSHALL, LONDON:—AND BY CONSTABLE
AND CO. EDINBURGH: AND PENMAN,

GLASGOW.



AERE FLAMMANS.



CONTENTS

OF THE SIXTY-FOURTH VOLUME.

ON Professor DÖBEREINER's new Mode of producing Fire. By Dr. J. S. C. SCHWEIGGER	Page 3
Description of a Hydro-pneumatic Pump for compressing Gases or other elastic Fluids. By Mr. SAMUEL SEAWARD	12
Introduction to the Sixth Section of BESSEL's Astronomical Ob- servations.	17
On the Corrosion of Copper Sheeting by Sea-Water, and on Methods of preventing this Effect; and on their Application to Ships of War and other Ships. By Sir HUMPHRY DAVY, Bart. Pres. R.S.	30
Solution of a Geodetical Problem. By J. IVORY, Esq. M.A. F.R.S.	35
Analyses of a Series of Papers on the Structure, Distribu- tion, and Functions of the Nerves; by CHARLES BELL, Esq.; which have appeared in some late Volumes of the Philosophical Transactions.	41, 119, 353, 442
Some Observations on the Migration of Birds. By the late EDWARD JENNER, M.D. F.R.S.; with an Introductory Let- ter to Sir HUMPHRY DAVY, Bart. Pres. R.S., by the Rev. G. C. JENNER.	50, 91
Observations on the Mesembryanthea barbata. By A. H. HAWORTH, Esq. F.L.S. &c.	61, 109
The Theory of Vegetable Physiology of M. AUBERT DU PETIT THOUARS; or of the Increase of Plants by means of Buds, or fixed Embryos. By JOHN LINDLEY, Esq. F.L.S.	81
On the Extraction of Selenium from the Residuum of the Sul- phuric Acid Works of Lukawitz in Bohemia; and on the Cause of the Odour of Tellurium. By Professor SCHOLZ, of the Polytechnic Institution of Vienna	83
Hints towards the Natural History of the Toad. By WILLIAM FOTHERGILL, Esq.	85
Introduction to the Seventh Section of BESSEL's Astronomical Observations	102, 170, 249, 341, 415
An Account of the Mesembryanthea ringentia. By A. H. HA- WORTH, Esq. F.L.S. &c.	109
A Sketch of the Progress of Science respecting Igneous Meteors	

CONTENTS.

<i>and Meteorites during the Year 1823 ; including an Account of the principal Phenomena of that Nature observed during the same Period : with Inquiries suggested by those Subjects.</i> By E. W. BRAYLEY, junior, A.L.S., and Member of the Meteorological Society	111, 287
<i>On Mr. SAMUEL SEAWARD'S Claim to the Invention of a Hydro-pneumatic Pump for compressing Gases, &c.</i> By Mr. JOHN MARTINEAU	129
<i>An Attempt to explain the Action of the Voltaic Pile.</i> By Mr. THOMAS POLLOCK	129
<i>Of Semi-decussation of the Optic Nerves.</i> By WILLIAM HYDE WOLLASTON, M.D. V.P.R.S.	134
<i>Observations on the Heights of Places in the Trigonometrical Survey of Great Britain, and upon the Latitude of Arbury Hill.</i> By B. BEVAN, Esq.	140
<i>Remarks on the Experiments of the Pendulum made by Captain KATER, M. BIOT, &c.</i> By WILLIAM GALBRAITH, Esq. A.M.	161
<i>On the Velocity of Sound; and on the ENCKE Planet.</i> By Mr. JOHN FAREY	178
<i>Observations on the Twelfth Book of Euclid.</i> By J. WALSH, Esq.	181
<i>Decas novarum Plantarum Succulentarum; A Decade of New Succulent Plants.</i> By A. H. HAWORTH, Esq. F.L.S. &c.	184,
<i>Decas Secunda</i>	298,
<i>Decas Tertia</i>	423
<i>Some Remarks on the supposed Influence of the Pollen in Cross-breeding, upon the Colour of the Seed-coats of Plants, and the Qualities of their Fruits.</i> By THOMAS ANDREW KNIGHT, Esq. F.R.S., &c. President of the Horticultural Society	191
<i>Observations on the Effects of Age upon Fruit Trees of different Kinds; with an Account of some new Varieties of Nectarines.</i> By THOMAS ANDREW KNIGHT, Esq. F.R.S. &c. Pres. of the Hort. Soc.	194
<i>On the complete Solution of certain Functional Equations.</i> By JOHN HERAPATH, Esq.	197
<i>On the Specific Heat of the Gases.</i> By W. T. HAYCRAFT, Esq.	200, 262
<i>On Comparative Barometric and Pluviometric Observations; in Reply to Mr. SQUIRE.</i> By W. BURNEY, LL.D.	208
<i>On finding the exact Mean Solar Time.</i> By Mr. SAMUEL COOPER.	210
<i>Sketch of the Geographical Distribution of Plants in Yorkshire.</i> By J. ATKINSON, Esq. F.L.S. &c. Leeds	211
<i>On the Theories of Vegetation of Sir J. E. SMITH and M. DU PETIT THOUARS.</i> By Sir JAMES EDWARD SMITH, President of the Linnæan Society.	241

CONTENTS.

<i>On Electro-Magnetism.</i> By Mr. W. STURGEON . . .	242
<i>An improved Demoustration of Sir ISAAC NEWTON'S Binomial Theorem, on Fluxional Principles, more especially calculated for the young Student in Mathematics.</i> By the Rev. L. EVANS, F.R.S. and A.S. &c.	270
<i>Remarks on the Gothic Ornaments of the Duomo, Battistero, and Campo Santo of Pisa.</i> By ARTHUR TAYLOR, Esq. F.S.A. Member of the Roman Academy of Arcadians . . .	273
<i>On the Local Attraction of Vessels.—In a Letter from Admiral KRUSENSTERN of the Imperial Russian Navy to PETER BARLOW, Esq. F.R.S.</i>	283
<i>Reply to Mr. SAMUEL COOPER'S Queries on finding the exact Mean Solar Time.</i> By GLOSTERIAN.	295
<i>On the Weights and Measures.</i> By Mr. THO ^s TREDGOLD	302
<i>Contributions to our Knowledge of Chemical Bodies.</i> By Mr. W. HERAPATH	321
<i>On the Calculus of Variations.</i> By JOHN WALSH, Esq. . .	330
<i>On the Transformation of the Solutions of a Periodical Functional Equation.</i> By JOHN HERAPATH, Esq.	333
<i>Statement on the part of the Monthly Critical Gazette respecting the Review of Sir J. E. SMITH'S English Flora in that Publication.</i> By A CORRESPONDENT	339
<i>On finding the exact Mean Solar Time.</i> By M. SMITH, Esq.	350
<i>On finding the Latitude by the Altitudes of two Stars.</i> By M. SMITH, Esq.	351
<i>Apparent Right Ascension and Declination of the four Minor Planets, at and about their ensuing Opposition.</i> By S. GROOMBRIDGE, Esq.	359
<i>On Weights and Measures, and on numerical Notations, in Reply to Mr. TREDGOLD.</i> By DECAPHILUS	362
<i>On some Extraordinary Inconsistencies in the Greenwich Observations for 1821.</i> By S. LEE, Esq.	367, 451
<i>On some Observations in the Meteorological Register.</i> By W. BURNEY, LL.D.	370
<i>On the Electro-motive Actions of Water and Liquids in general on Metals: and of the electric Effects which take place—first, in the Contact of certain Flames and Metals; secondly, in Combustion.</i> By M. BECQUEREL, Ancien Chef de Bataillon du Génie	401
<i>On a new Fossil Genus, of the Order Enalio Sauri (of Conybeare): and on a new Species of Ichthyosaurus.</i> By R. HARRLAN, M.D. With a Note by the Rev. W. D. CONYBEARE.	409
<i>On Lava found on the Sands near Boulogne.</i> By ROBERT BAKEWELL, Esq.	414

CONTENTS.

<i>Tables for facilitating the Calculation of the Mean Time of the Passage of Stars over the Meridian; for the Use of those who observe by Clocks or Chronometers showing Mean Solar Time. Computed by Mr. P. LECOUNT</i>	428
<i>Meteorological Register kept at WICK, in the County of Caithness, near the Northern Extremity of Scotland, for 1823</i>	431
<i>On a Hydro-pneumatic Pump. By Mr. SAM. SEAWARD</i>	441
<i>Upon the System of Vegetable Physiology of M. AUBERT DU PETIT THOUARS: in Reply to Sir JAS. EDW. SMITH. By J. LINDLEY, Esq. F.L.S. &c.</i>	456
<i>Notices respecting New Books</i>	62, 143, 218, 304, 371, 457
<i>Proceedings of Learned Societies</i>	65, 147, 305, 374, 459
<i>Intelligence and Miscellaneous Articles</i>	67, 149, 229, 309, 383, 467
<i>List of Patents</i>	79, 159, 239, 318, 398, 472
<i>Meteorological Tables</i>	80, 160, 240, 320, 400, 473



PLATES.

- I. Hydro-pneumatic Pump for compressing Gases.
- II. Mr. STURGEON'S Electro-magnetic Rotating Apparatus; and Mr. HAYCRAFT'S Apparatus for ascertaining the Specific Heat of Gases.
- III. Fossil Remains of two new Saurian Animals found in America:—*Saurocephalus lanciformis*, and *Ichthyosaurus coniformis*.

ERRATA:

- Page 65, line 9, for Solenhoffer, read Solenhoffen.
 Page 66, line 16, for M. le Baron Blias, read M. le Baron Blin.
 Page 67, line 10, for Mariand de Rivero, read Mariano de Rivero.
 Page 249, line 8, for east to west, read west to east.
 Page 297 in each of the Tables, for 21, 22, 23, 24 Min., and 21, 22, 23, 24 Sec., read 30, 40, 50, 60 Min., and 30, 40, 50, 60 Sec.

THE
PHILOSOPHICAL MAGAZINE
AND JOURNAL.

31st JULY 1824.

I. *On Professor DÆBEREINER'S new Mode of producing Fire.* By Dr. J. S. C. SCHWEIGGER*.

SUCH new and interesting phænomena as those of which mention has been made by M. Dæbereiner, naturally excite the wish to connect them, if possible, with the series of other phænomena of nature already known. Every trial of this sort, however fruitless it may end, will at least contribute to show the object from more than one point of view, and by that means to facilitate the development of the mystery. The following observations were caused by a small publication, to which we wish to direct the reader's attention. It is entitled, *On the newly discovered and very remarkable Properties of Platinum, and the Pneumatic Capillary Agency of cracked Glass*; by J. W. Dæbereiner. Jena 1823. In this pamphlet, we find, in page 6, under the head "*Fruitless Endeavour to explain satisfactorily the newly-discovered Property of Platinum,*" the following remark: "As the hydrogen is neither absorbed nor condensed by the metallic platinum dust, and yet the inflammability of the former so much heightened, when in contact with the latter, that it attracts oxygen in a diluted state, in which an electric spark cannot effect their union, *the effect cannot be considered as resulting from any mechanical agency of the platinum*; but it must be supposed, in order to explain the phænomena satisfactorily, either that the hydrogen gas forms an electrical combination with the platinum, in which the former represents the exciting and inflammable agent, or the zinc, or that the entire phænomenon is determined by the peculiar form of the atoms of the platinum. On the former supposition, we must assume that hydrogen is a substance of a metallic nature; and on the latter, consider the spongy platinum,

* From his *Neue Journal für Chemie*, &c. band ix. p. 211.

with M. Schweigger, as possessing a crystallo-electric power.—In order to examine these suppositions, I have made a great number of experiments, but have not yet obtained any result in confirmation of either. I brought into contact with the explosive mixture, entire and broken pieces of boracite, tourmaline, diamonds, finely powdered coal, graphite, silver and copper dust; and none of these substances effected, at common temperatures, a condensation of the gases. No condensation of hydrogen occurred when I placed it in contact with platinum dust, and the following substances respectively: peroxide of manganese, carbonic oxide, carbonic acid, nitrous gas, and other oxides. I further exposed the platinum dust to mixtures, 1st, of carburetted hydrogen and carbonic acid gas; 2dly, of olefiant gas and carbonic oxide; 3dly, of the vapour of alcohol and carbonic acid gas; 4thly, of sulphuretted hydrogen and carbonic acid gas; but none of these mixtures became condensed or changed in their nature. I expected the reverse; for I thought that the elements of water, which are contained in all these gaseous mixtures, would act upon each other, and would by that means give rise to new combinations. This and many other experiments, by which I endeavoured to ascertain the relation of hydrogen gas, when combined with other substances, as in ammonia and sulphuretted hydrogen, olefiant gas and carburetted hydrogen, to platinum and oxygen gas,—convinced me, that the action of that metal is confined to mixtures of free hydrogen and oxygen gas; and that its action is probably of a peculiar nature—that it is neither mechanical, electric, nor magnetic.”

Although I perfectly agree with my friend Dœbereiner, that these remarkable phænomena are owing to some *new principle of nature*, yet I am inclined to follow the hint thrown out by him in the passage just cited, to investigate these phænomena, after my own manner, on the principles of crystallo-electricity; and to combine with them other phænomena, the union of the observations on which will, perhaps, be useful for further investigations. An arrangement of a series of phænomena so as to connect any particular phænomenon with the whole, in a natural manner, is alone what we understand by a theory in physics. With respect to my electro-chemical theory, I am not satisfied, as is usually the case, by merely calling the chemical attraction an electrical one; by which change of name, it appears to me that but little is gained, so long as we do not refer the particular chemical changes of bodies to electrical laws, but continue to deduce them, in the old manner, with Dr. Black, from fixed caloric. The Voltaic battery has in a direct manner forced us to renounce the language of Black's
theory

theory of caloric in some particular cases. But while one says that the atoms or molecules of acids are electro-negative, because they move towards the positive pole, and that the atoms of bases are electro-positive, because they are attracted by the negative pole; while properties evidently belonging to the entire masses of bodies are thus ascribed to the supposed properties of their atoms—but little is actually gained; even without considering how relative the notions of acid and base are, by which alone the electro-chemical theory, which is grounded exclusively on the phænomena of the Voltaic battery, and which only expresses these phænomena in a more general manner, is often involved in great perplexity. It is curious, however, that other phænomena, much longer known and not less remarkable than those of the Voltaic battery—I mean the crystallo-electric phænomena—should so little have attracted the attention of philosophers, that they have not found their merited place either in the compendiums of natural philosophy or of mineralogy; but have been referred by the natural philosopher to the mineralogist, and by the latter again to the former, being merely mentioned occasionally in a note. It is therefore right to say, at last, to the neglected guest at the bottom of the table of natural philosophy, “Friend, approach nearer!” if it were only to see what would result when he should be seated at the top. I will therefore endeavour to deduce not only the chemical, but also the general attraction of bodies, from these crystallo-electrical laws; for which reason I must refer to preceding volumes of this Journal*. As we observe all bodies to divide according to their crystalline texture, which is even the case with the finest chemical precipitates, it is hard to conceive how it could have been supposed, that crystalline divisibility ends where our microscopic observations terminate; and that liquids consist of spherical atoms, so that the terms *liquid* and *without form* are synonymous; while the ideas of Matter and of Form are in their nature inseparable. The notion of a liquid being nothing else than that of an infinite mobility; that is, if we suppose that the universal attraction of bodies depends upon crystallo-electrical laws, by a liquid will be meant an electric indifference to all the crystalline differentials. Not only when we suppose the infinite limit of divisibility obtained, which supposition is unnecessary even in the *mathematical analysis*, the notion of crystalline differentials will disappear. But it is a shallow presumption, when we suppose, with the notion of

* See vol. v. pp. 49—74; vol. vi. pp. 250, 254; vol. vii. pp. 302—308, and 515; vol. viii. p. 307; vol. xi. pp. 54, 330, 435; vol. xiv. pp. 510—516; vol. xxv. pp. 158—173.

a liquid,

a liquid, to have attained the limit of the infinite even in idea. On the other hand, we find, when we take experience for our guide, one and the same body—as for instance, acetic acid—as at one and the same temperature appear as well in a crystalline as in a liquid or gaseous form, those states being dependent only on various pressures of the atmosphere*. And we knew long since, that in some experiments on the polarisation of light, some liquids produce effects which are dependent upon a crystalline double refraction of the rays of light; as for instance, camphor has in its solid state a double refraction, and reproduces, in the well known experiment of Malus, the double image which has disappeared; but it retains that property in its liquid state, of which I have convinced myself by an experiment instituted expressly for that purpose. The same is known to be the case with camphor dissolved in spirits of wine. Even polarisations like those of crystals of attractive or repulsive axes appear in some liquids. The crystalline nature of the differentials of many liquids can be proved, therefore, by direct experiment. In this our differential calculus of physics, the step is therefore unavoidably taken to consider the elastic fluids under the same point of view as I have done in the former series of this work (see vol. v. p. 60). Indeed this assumption, though at variance with the somewhat surprising notion commonly entertained on that subject, has already obtained the assent of several exact chemists †.

* The experiments of Mr. Perkins on this subject will soon be made known.

† Compare, for instance, the *Review of the principal Features of the present State of Chemistry*; by Professor Von Ittner, Freiburg, 1823. On the other hand, I must be excused for not paying any attention to what M. Osann has stated in regard to my theory, in his Treatise on those substances which congeal when heated, and become liquid again upon cooling, inserted in Gilbert's *Annals*, vol. lxix. p. 283—300. M. Osann completed the greater part of this Treatise under my direction, and made most of the experiments contained in it in my presence, and in my laboratory. But it is to be wished that he had given a greater degree of perfection to his more recent labours, and particularly that he had paid more attention to the diminished solubility of lime, as also of several other substances at an elevated temperature. I must also refer him to some other things; particularly to the remarkable observation made by M. Bucholz on the crystalline precipitate of the sub-nitrate of bismuth, even when dissolved in an excess of water, by the mere increase of heat; which latter phenomenon M. Osann has cited, in p. 300, in a very incorrect manner, because he has not taken the trouble to read attentively the passage cited from Bucholz's *Contributions to the Extension of Chemistry*, No. II. p. 60, and No. III. p. 1. M. Osann has in every respect been precipitate in his publication. He has overlooked, in his hurry, that the theory which he considers as peculiarly his own, is the very same as that of M. Gay-Lussac, which I had mentioned in my Essay, which has been attacked, but scarcely read, by M. Osann: a theory which was given up by M. Gay-Lussac himself in consequence of his own further experiments.

The

The phænomena of light, which appear by a sudden compression of the air, but never on a slow compression of it, however powerful, will be deducible from an electric reversion, when considered under the same point of view, which is often indicated when bodies in the same electrical state are quickly moved towards each other, that the weaker electricity is opposed by the stronger, as is the case with magnets. It is an opinion which contradicts itself, to suppose that those appearances of light are owing to a mechanical expulsion of caloric which has been chemically fixed in the air. In order to cover a little this contradiction, it is said that the capacity of the air for caloric is diminished by compression: but this means nothing else, we would say, but that light and caloric become free, because they become free. Besides this, such a peculiar explanation cannot assign any reason why those appearances of light are never elicited by a rapid compression of hydrogen or azote, but always in a high degree in that of oxygen or halogen [chlorine]. Neither can the favourite theory of fixed caloric assign any ground of distinction in this respect with regard to the last-mentioned gases, since they, like the former, consist of a ponderable base and of fixed caloric. Why, therefore, does this fixed caloric appear with such strong light only in those gases which are attracted to the positive pole of the Voltaic battery, viz. in oxygen and in chlorine? According to my crystallo-electrical theory, I can with good reason assume, that the crystalline differentials of the last-mentioned gases repel each other with a predominant negative electricity, on account of their being attracted by the positive pole of the Voltaic battery at the moment of their becoming free. If therefore such gases are forcibly compressed, it is the positive electricity which is excited by the electric reversion of the poles of many rapidly approaching crystals. But it is known, that positive electricity possesses a strong radiating power, which negative electricity, constantly appearing in a faint light, is deficient in. It is therefore the latter, which according to our crystallo-electrical theory will appear in a strong compression of hydrogen, and generally of all those gases which are attracted to the negative pole. For this reason will the compression of such gases elicit caloric only, and not light. It should not be objected that a decided manifestation of electricity has never been perceived in these appearances of light; for as the products of both electricities, viz. light and heat, are present, the appearance of the electricities separately cannot be expected. Moreover, the crystallo-electricity is here meant, which, as is well known, imparts itself but with difficulty, where it appears the more powerful, as is the case in the
the

the tourmaline. But every thing which facilitates the appearance of the electricity will be favourable to those appearances of light and caloric in the compression of the gases, according to my theory: and that this is really the case, I shall now proceed to show. The paper on "*The Light produced by the Discharge of an Air-gun;*" by Mr. John Hart, inserted in the *Journal of Science*, vol. xv. p. 64, affords an interesting confirmation of the theory now proposed, and shall therefore be given as an Appendix to the present essay. All the experiments made by Mr. Hart, in order to produce light by the discharge of an air-gun, failed, until he accidentally discharged some paper wadding, when he perceived a faint light, which, however, he could not reproduce by a repetition of the experiment. He therefore tried other bodies: but neither clean dry silk, woollen, paper, nor wood, would answer, and even shell-lac only succeeded occasionally; whilst sugar, but especially narrow slips of glass, never failed in producing the effect. It appeared at length that even some particles of lime or sand produced a luminous discharge, and that when sand or fragments of sugar were held at the muzzle of the air-gun, while the stream of air was rushing forth, they appeared luminous. We find this paper translated in the *Annales de Chimie*, tom. xxii. p. 436-439; and the Editors, in confirmation of Mr. Hart's results, observe, that when we blow with a clean pair of bellows on even the most delicate electrometer, no sign of electricity is obtained; whereas when the bellows contain a little powder or ashes, the electricity produced is very strong.

Mr. Hart explains these phænomena by the electrical friction of the bodies. But he will hardly be able to state, why the bodies which so easily become electric, as silk, woollen, and shell-lac, would not answer in his experiments; while it was only necessary to throw the silk on the floor, so that it might become dusty, for a luminous discharge to take place. With these experiments the following observation may be connected. I have received from General von Hellwig (who long since intended to make experiments on the compression of air by an hydraulic-press, like those lately instituted in England) a glass apparatus for producing fire by compression, constructed in a most convenient manner, like that represented by M. Thenard in his *Traité de Chimie*, tab. xxii. fig. 3. The polished bore of the tube in which the accurately fitting piston moves, is scarcely half an inch in diameter, whilst the glass forming the tube measures about an inch in thickness. The appearances of light upon the violent compression of the air are very easily perceptible in this instrument; and when a small piece of amadou is affixed to the

the hook of the piston, it usually becomes ignited at the first stroke, by a most vivid flash. When the amadou is not used, a more powerful stroke is necessary for the production of light; and when the piston is perfectly clean, one may sometimes repeat the experiment ten times before that effect is produced.

The smallest piece of amadou, however, fixed to the hook of the piston, facilitates the evolution of the light, and heightens its brilliancy. Care only is to be taken that it may contain many fibres, and for that reason it should not be compressed with the fingers. It is strikingly manifested by this experiment that the amadou does not act a merely passive part when ignited by the flash, but that it contributes to the easier excitement of the light, which is too brilliant to be mistaken for the weak combustion of some points of the amadou, when glowing under the smoke. There can be no doubt that this is the fact, when we compare the experiment with those of Mr. Hart already cited. Now it is well known that the projecting fibres of amadou best adapt it for the absorption of electricity. It was lately announced in a French Journal, that this substance is particularly remarkable for this property of drawing electricity from electrified bodies, and that with rapidity and in great quantity: and MM. Lefèvre-Gineau and Pouillet have actually found that a piece of this substance absorbs electricity, when placed opposite to a charged conductor, at a greater distance than even a metal point. If it be made wet, however, this property, which evidently arises from its fibrous and spongy structure, becomes diminished*.

The amadou in the apparatus for producing fire by compression above described, operates altogether with the same modifications. I substituted for it metallic points, and they also appeared to a considerable degree to favour the appearance of light, though not to the same extent, as the action on such tender electrical crystals as our theory supposes to exist in elastic fluids depends so much upon the softness and abundance of the points.

Now let a metallic amadou be conceived; that is, the effect of metallic points united with the spongy structure; and this moreover in a metal, like platinum, easily ignited by electricity †; will not such a metallic sponge greatly facilitate the development

* See Gilbert's *Annalen*, band 73; or the new series, band 13, p. 127.

† While copper is easily melted in a moderate fire, and platinum is infusible, they become reversed with respect to electric fire; from which latter circumstance it has usually been concluded, that copper is a far better conductor of electricity than platinum, which of all the metals is also the

development of electricity by the agency of points, in mixtures of gases strongly opposed in electric polarity? and this in a greater degree proportionably to the tendency to development of the electricities under ordinary circumstances, that is, the further those gases are distant from each other in the electro-chemical series, or the more powerful their inclination to combine. But we are unacquainted with more strongly opposed electro-chemical poles than oxygen and hydrogen, which are the extreme links of a series formed by arranging all bodies between the two wires of the Voltaic battery.

But why does platinum contribute in so distinguished a manner to this combination?—Because it is best adapted for a spongy mass, by its not melting in a common fire. The metals nickel and palladium may be added to platinum with regard to this latter aptitude. According to Dulong and Thenard's observations, the "platinum in the spongy state strongly calcined, loses the property of becoming incandescent; but in this case, it causes the combination of the two gases slowly, and without a very sensible raising of the temperature*:" which is according to our theory, that if the points of the platinum sponge are made to melt in consequence of a strong calcination, and by which they lose their angles, the experiment, which is founded on the agency of points, will be less successful.

Agreeably to this theory I had offered the supposition, that platinum powder prepared by mechanical means would operate with still less energy; and this is really the case. In the same manner, a smooth and thin leaf of platinum does not operate until it is crumpled; which again shows the influence of points. The experiments which the French chemists made on the agency of some metals in the decomposition of ammonia, are beautiful and ingenious. The observation, first made by Thenard, is to be found at large in the former series of this Journal (see band vii. p. 299, &c.), and even at that time I added an appendix, in order to explain this remarkable phenomenon according to the laws of crystallo-electricity. In like manner the observations of Gay-Lussac on the decomposition of the vapour of prussic acid must be considered as supporting this theory (see band xvi. p. 14). MM. Dulong and Thenard, at the conclusion of their memoir occasioned by the ingenious experiment of Dæbereiner, express the supposition,

worst conductor of heat. It is probable, however, that the ground of the former property lies still deeper, and perhaps in this newly-discovered principle. It may also be mentioned here, that M. Hildebrandt, in his Treatise on light emanating from electrical points, attributes to platinum a great power of exciting it.

* See Phil. Mag. vol. lxii. p. 284.

that

that an opposition may exist between the noble and inferior metals, so far that the latter are favourable to the decomposition, and the former to the union, of gases. But this is very doubtful: for without considering that chemical combination and decomposition are not different in principle, and are under most circumstances inseparable, those very noble metals and their oxides are the most powerful agents in the decomposition of oxygenated water, that is, the expulsion of its oxygen with the evolution of caloric and light. The experiment with the aphlogistic lamp, which is the very reverse of M. Thenard's experiment with ammonia, most easily succeeds, next to platinum, with iron wire; in which therefore the iron, which promotes the decomposition of the ammonia as well as of the prussic acid, at an increased temperature, also favours the union of oxygen and hydrogen at the same elevated temperature. It is not to be denied that the experiment with the aphlogistic lamp depends also on the fullness of the points of contact; and that we therefore find the union of the gases to be favoured by the same circumstance by which the formation of crystals is promoted. When attentively considered, chemical and crystalline attraction will appear to be the same, as it is well known that every chemical precipitate appears in a crystalline form under the microscope. This is illustrated by a very interesting experiment made by my friend M. Vogel, a very ingenious chemist, formerly a resident at Bayreuth, whose early death was a great loss to the science. He first observed the combination of oxygen and hydrogen at a low temperature, under the influence of charcoal. It is true, that in this experiment charcoal impregnated with hydrogen must be employed, by which the atmospheric air becomes at the same time deoxygenated. If, however, one should be inclined to reduce that power of the charcoal to a mechanical principle, it should also be considered, that the hydrogen will be more perfectly divided, and most fully in contact with the oxygen, when mixed with the latter in a gaseous form, than when previously absorbed by the charcoal: and when we consider, moreover, that hydrogen not only adheres mechanically to the charcoal, especially when absorbed with water, but becomes condensed, it ought not to be forgotten, that hydrogen and oxygen may be greatly condensed in the gas blow-pipe, and will remain for years in that state, without combining with each other, when the compression is effected slowly and quietly. In this interesting experiment of M. Vogel likewise we find that the many points of contact effect the union of the gases. The effect, however, in this instance is more slow and feeble than in the experiment of Dæbereiner.

This is what I had to state, from the crystallo-electric theory, respecting the new mode of producing fire, discovered by Prof. Dœbereiner. I do not consider this explanation as entirely satisfactory; but I think it not unbecoming the present state of natural philosophy, if at least I have succeeded in thereby connecting it with the other phænomena of nature: if any thing is to be advanced on this subject from the electro-chemical theory, it is only the crystallo-electricity that can throw any light upon it. As hydroguretted carbon stands near to the zinc in the positive electric series, while oxidated carbon is still more negatively electric than silver or platinum, it was certainly in that respect a very ingenious supposition of M. Dœbereiner, when he compared the activity of the hydrogen with regard to the platinum* to that of zinc; and that he so far thought of the excitement of electricity by contact. Soon afterwards, however, he renounced this theory, in his public reading before the Assembly of Naturalists at this place (Halle), which at present would be even less tenable, as even carbonic oxide gas is made to unite with oxygen by the platinum sponge, as we have just seen from the dissertation of the French chemists †. With regard to the electro-chemical explanation, it appears that the above view of crystallo-electricity alone remains.

For the illustration of the preceding Essay, I will add an encyclopedic review of my crystallo-electric theory, the consideration of which gains in interest on account of Dœbereiner's important experiments. This will be nearly as published at a former period in the *Universal Encyclopedia*, conducted by Ersch and Gruber, under the article *Attraction* ‡.

II. *Description of a Hydro-pneumatic Pump for compressing Gases or other elastic Fluids.* By Mr. SAMUEL SEAWARD.

To the Editors of the Philosophical Magazine and Journal.

Gentlemen,

THE accompanying description of an hydro-pneumatic pump, which I have invented for the pressure of compressing gas, would have been forwarded to you a long time back, but I was desirous of seeing the machine tried before I offered it to the attention of the public. Being now fully satisfied on this point, as it performs all that was ex-

* See Phil. Mag. vol. lxii. p. 291.

† Ibid. p. 285.

‡ We purpose to give a translation of this account of the crystallo-electric theory in a future Number.—EDIT.

pected from it, I take the earliest opportunity of submitting it to your notice.

The original idea is due to Mr. David Gordon of the London Portable Gas Establishment, who published his views on the subject some time back in the *Repertory of Arts*,—though I believe this is the first pump of the sort that has ever been made. I am yours, &c.

Feb. 18, 1824.

SAMUEL SEAWARD.

IN consequence of the general use to which gas is likely to be brought when highly compressed, it becomes important to ascertain the best method of reducing it to that state, so that it shall be most useful and advantageous to the public.

The present method of compressing gas is attended with a great many disadvantages: these principally consist of a considerable loss of gas during the operation of compression, an immense loss of power in consequence of the gas not being completely forced out of the pump barrel, and the excessive wear and tear of the machinery employed therein.

The pump that has hitherto been used for this purpose consists of a barrel well bored out, open at one end (as A, fig. 1, Plate I.), with the two valves *c* and *d* at the other end; and the solid piston B working therein. This is, perhaps, the best possible arrangement of the piston pump, and is the one adopted by some of the first engineers and machinists.

Now, in the using of this pump it is impossible that the piston can be worked so close as to strike the bottom: there must be some space for clearance, otherwise there would be great danger of damaging the valves, or doing other mischief. Say, in a pump of 12-inch stroke and 5 inches diameter, the spaces allowed between the bottom of the piston and the bottom of the pump shall be one-eighth of an inch, which is no great deal; now as the operation of compression goes on, this space will be gradually increased, and when the gas arrives at a pressure of 30 atmospheres, or 450 lbs. upon the square inch (which is the average pressure employed by the Portable Gas Company), there will then be the enormous weight of 9000 lbs. acting against the bottom of the barrel and the piston, which will naturally cause them to recede the one from the other; and from the actual spring of the cranks, the looseness and wear of bearings, spring of the connecting rods and cross-heads, and even of the bottom of the pump itself, we may fairly conclude that under this great pressure the piston does not come within one quarter of an inch of the bottom; consequently there remains that quantity of gas under the great pressure

pressure of 30 atmospheres, which cannot be forced out, and which, as the piston recedes for the return stroke, will expand in the barrel, and occupy a great part of the space; thereby preventing the admission of another full charge.

And this is one of the great defects of this sort of pump; for, allowing the space to be one quarter of an inch, it will be just one forty-eighth of the whole capacity of the pump; and, adding to this the space left by the rising of the eduction valve *d*, which will remain open until the piston has receded a little in the return stroke, we may doubtless presume that a portion of compressed gas, equal in volume to one-fortieth of the whole stroke of the pump, remains behind every time in the barrel: therefore, when the pump commences working, and the gas in the receiver arrives at a pressure of 10 atmospheres, only three-fourths of the gas is forced out of the barrel;—at 20 atmospheres, one half;—at 30 atmospheres, one quarter;—and when it arrives at 40 atmospheres, the pump will cease to act, as the compressed gas which remains will expand itself, and fill the whole barrel: therefore no more gas can then be admitted from the gasometer. Moreover, there is an actual loss of gas occasioned by the leaking of the piston, which is a failing that these pumps are all more or less liable to; for, whether they be packed with metallic rings, cupped leathers, or hemp packing, still there will be some escape under this great pressure: and if the leathers &c. are screwed up so hard as totally to prevent the escape of the gas, the friction will become immense, consequently one-half the power will be absorbed, and thus very little advantage would be gained by the remedy.

These observations will, it is presumed, place the defective operation of the common forcing pump in a clear point of view, and will naturally lead us to comprehend the advantages of the hydro-pneumatic pump. It will have been observed, that the great evil in the common pump is the space or cavity that is left when the piston is down at the bottom of the stroke. Now the remedying of such evil is the primary object sought for in this improvement; for this purpose a quantity of non-elastic fluid is introduced into the chamber of the pump, which, filling up the whole of the cavity when the piston is down, necessarily forces out every particle of the compressed gas; the method of accomplishing which will be readily understood in the description of the new pump.

Fig. 2 is an elevation, and fig. 3 a plan of the hydro-pneumatic pump. A A is a frame for supporting the machine: the pump consists of two chambers B and D; in the chamber B works the solid plunger C, through a cupped leather (*v*), by
means

means of the crank (n) and the slings (mm). D is the pneumatic chamber, at the top of which are placed the induction valve (e) and the eduction valve (c): over the latter is placed a small vessel (g) with the pipe h leading to the receiver.

Now when the plunger C is at the bottom of the stroke, as shown in fig. 2, the pneumatic chamber D is then to be quite full of oil or some other non-elastic fluid; and for further security a small quantity of oil is also to be above the eduction valve (c):—when the plunger C is drawn back, the oil in the chamber D will sink to the level of (rs), and the space will then be filled with the gas, which will rush from the gasometer through the pipe (f) and valve (e): but when the plunger is again forced down, the oil will rise to the same height as before, again filling up the whole capacity of the chamber D, and forcing out every particle of gas through the valve (c); and so on alternately.

If, through the increased pressure, or from some other cause, the oil in the chamber D should not be quite sufficient to fill up the whole cavity on the return of the plunger, it is of no consequence, because the moment the valve (c) rises ever so little, the oil which was above the valve will descend and displace the gas in the chamber D. The vessel g is a small reservoir for the oil, and to receive any drainage from the gas: the tube (k) is for ascertaining that the proper quantity of oil is in the apparatus, or for supplying more when required.

It is possible that a trifling leak may take place through the valve (c); but this will be of little consequence, as the escape of a small quantity of a non-elastic fluid back into the chamber D is not attended with a twentieth part of the inconvenience to which the escape of the same volume of compressed gas would be subject.

Now the particular advantage of this pump is, that the full charge of gas is forced through the valve (c) at every stroke of the piston, whether the pressure be equal to 1, 10, or 50 atmospheres. Indeed there are no limits to the degree of compression of which this pump is capable; provided the parts of the machine be sufficiently strong to withstand the strain, and an adequate power be employed; while it is supposed that the operation of the common pump is not capable of extending beyond a pressure of 30 or 40 atmospheres.

The following diagram will furnish an easy method of ascertaining the power required to work the above pump sufficiently near for all practical purposes.

Thus let the straight line A B be divided into 32 equal parts;

parts; of which make $GB=16$; $FG=8$; $EF=4$; $DE=2$;

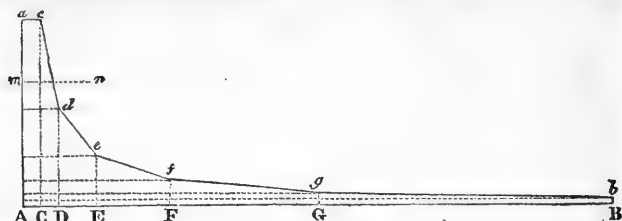

$CD=1$; and $AC=1$. Then if we consider this whole line equal to the space which the plunger moves over in one stroke of the pump, it is plain that at B, the commencement of the stroke, the force will be equal to one atmosphere only, represented by the vertical line Bb : but when the plunger has reached G, it will have made half a stroke, and the force will then be equal to 2 atmospheres, as shown by the line $Gg=2 \times Bb$. Again, when the plunger is at F, it will have made three quarters of the stroke, and the force will then be equal to 4 atmospheres $= Ff=4Bb$; and so on, until the plunger arrives at C, when it will have made $\frac{3}{2}$ part of the stroke, and the compression and force will then be equal to 32 atmospheres equal the line $Cc=32 \times Bb$.

Therefore if we consider $bg, gf, fe, \&c.$ as so many straight lines, then will the areas $Gbg, Ffg, Efe, Dcd, \&c.$ be nearly as the momenta of the plunger passing over the several spaces BG, GF, FE, &c. But these several areas $Gbg, Ffg, Efe, \&c.$ are all equal to each other; therefore the whole of the momenta of the plunger passing through the space BC, will be equal five times the area $GgbB$; that is, equal to $5 \times$

$$\frac{gG+Bb \times GB}{2} = 5 \times \frac{1}{2} \times 16 = 120.$$

To this must now be added the momenta of the plunger passing from C to A, the last $\frac{1}{2}$ part of the stroke, which will be as $32 \times 1 = 32^*$; which added to the above gives 152. We have now to deduct the pressure of one atmosphere which has assisted the plunger in passing over the space BA; that is. $32 \times 1 = 32$, which taken from the foregoing quantity will leave 120 for the whole absolute momenta of the plunger. Now divide this quantity by the number of parts in the line AB

* Because when the gas in the chamber is compressed equal to 32 atmospheres, it will then raise the valve and make its escape into the receiver, as we suppose the pressure not to exceed 32 atmospheres.

(= 32),

(=32), and it will give $3\frac{3}{4}$ atmospheres, or $56\frac{1}{4}$ lbs. per square inch for the average force on the plunger during the whole stroke, when compressing gas equal to 32 atmospheres.

Therefore as the pump acts but singly, if a fly-wheel of sufficient weight be employed, a power equal to about 30 lbs. on every square inch of the area of the plunger will be nearly adequate to the working of the pump.

If gas of the pressure of only 20 or any other number of atmospheres less than 32, be required, the necessary average power for producing it can readily be ascertained from the same diagram; for let the line *Am* represent the proposed pressure, then cutting off the upper part of the figure by the line *mn*, parallel to the base *AB*; and calculating the remaining area, in the manner already described, it will give the required power. And if the pressure should be required to be more than 32 atmospheres, then by increasing the height of the diagram towards *ac* in the manner already shown, we can also in that case estimate nearly the necessary required power.

III. Introduction to the Sixth Section of BESSEL'S *Astronomical Observations*.

[Continued from vol. lxiii. p. 443.]

6. *Observations of circumpolar Stars.*

THE reduction of the observations of these stars to the beginning of the year 1820, was undertaken by Mr. Argelander, who has been employed since the autumn of 1820 as assistant in the Observatory, and has already obtained by observation and calculation many results useful to science, of which I expect to publish in the next section of my *Observations* such parts as belong to the subject of this work. The fundamental catalogue of Königsberg is the foundation of the present computation; the reductions have been made by the small tables, the publication of which Professor Schumacher has kindly undertaken. In the following table, which is arranged according to polar distance, the first column contains the mean of observations made above and below the pole, the same value having been given to both from the pole to α *Aurigæ* exclusive; and from this star down to the horizon the value of the lower passages having been diminished according to a scale supplied by the observatories themselves. The remaining four columns contain the differences of the determinations obtained in the four different ways from the mean ones.

				Upper Passage.				Lower Passage.				
	Decl.	R 1820.	No.	East.	No.	West.	No.	East.	No.	West.	No.	
	h											
ζ Ursæ Min.	78° 21'	15 50'	42:439	33 +0"110	6 +0"149	11 +0"060	9 -0"406	7				
γ Cephei	76 37	23 32	2:812	76 +0"044	23 +0"010	17 +0"028	14 -0"071	22				
β Ursæ Min.	74 54	14 51	20:568	30 +0"249	8 +0"009	11 -0"238	6 -0"132	5				
γ —	72 29	15 21	5:721	42 +0"247	10 +0"002	12 -0"210	11 -0"022	9				
α Draconis	70 47	12 25	44:512	40 +0"103	5 +0"042	14 -0"133	9 +0"009	12				
λ —	70 19	11 20	35:750	37 +0"060	8 +0"116	11 -0"183	12 +0"150	6				
β Cephei	69 46	21 26	17:952	42 +0"129	11 -0"042	13 +0"112	7 -0"151	11				
α Ursæ Maj.	62 43	10 52	31:754	38 +0"031	10 +0"076	8 -0"088	11 +0"006	9				
η Draconis	61 55	16 21	34:399	33 +0"049	9 -0"033	9 +0"002	9 -0"027	6				
α Cephei	61 49	21 14	16:581	46 +0"034	9 +0"017	15 +0"099	9 -0"113	13				
66 Draconis	61 28	20 2	40:083	37 +0"053	9 +0"012	9 +0"018	11 -0"098	8				
η Cephei	61 8	20 41	36:787	42 +0"122	11 +0"018	11 -0"005	9 -0"135	11				
10 —	60 19	11 20	15:490	35 +0"024	5 -0"024	12 +0"022	10 -0"019	8				
P. XX. 222	59 49	20 28	23:093	35 +0"071	10 -0"008	9 +0"010	8 -0"088	8				
ο Draconis	59 10	18 48	32:426	38 +0"025	6 -0"050	12 +0"027	10 +0"017	10				
θ —	59 3	15 58	31:807	37 +0"033	11 -0"058	9 +0"054	10 -0"053	7				
δ 2 Cep. Hev.	58 22	19 52	28:800	37 +0"034	9 +0"016	10 +0"002	9 -0"052	9				
48 Draconis	57 35	18 53	42:291	38 +0"048	6 -0"083	12 +0"083	10 -0"014	10				
δ Cephei	57 30	22 22	30:415	39 +0"045	9 +0"047	12 -0"052	13 -0"060	6				
ζ —	57 19	22 4	37:398	48 +0"093	12 +0"035	13 -0"008	13 -0"147	10				
53 Draconis	56 33	19 8	16:048	38 +0"080	6 -0"074	12 +0"044	10 -0"004	10				
ι Cephei	56 9	22 8	25:424	31 -0"038	7 -0"017	7 +0"052	12 -0"045	5				
33 Cygni	56 2	20 8	12:571	32 +0"036	8 -0"037	6 +0"074	10 -0"100	8				
μ Cephei	55 46	21 48	50:715	22 -0"002	3 +0"051	7 +0"023	8 -0"132	4				
α Cassiopeiæ	55 33	0 30	21:293	53 -0"047	12 +0"026	15 -0"097	9 +0"051	17				
49 Draconis	55 24	18 57	9:623	35 +0"038	6 -0"018	12 +0"020	10 -0"028	7				
P. XXI. 336	55 22	21 47	3:642	22 +0"049	6 +0"012	7 -0"016	5 -0"101	4				
c Draconis	55 21	18 39	8:793	18 -0"042	6 -0"022	11 —	—	1				
γ Ursæ Maj.	54 42	11 44	19:051	50 +0"045	10 -0"072	16 +0"033	10 +0"027	14				
P. XX. 391	53 50	20 48	9:762	37 +0"034	10 +0"034	10 +0"067	7 -0"109	10				
51 Draconis	53 6	19 0	52:456	37 -0"003	6 -0"028	12 +0"055	10 -0"011	9				
κ Cygni	53 2	19 12	56:451	39 +0"048	6 -0"033	13 +0"050	10 -0"037	10				
P. XXI. 32	52 50	21 4	41:911	31 +0"013	6 +0"071	10 +0"043	8 -0"162	7				
20 Cygni	52 32	19 46	6:713	37 +0"069	7 -0"062	12 +0"045	9 -0"017	9				
β Draconis	52 26	17 26	22:264	41 +0"036	11 -0"037	8 -0"005	15 +0"009	7				
γ —	51 31	17 52	25:814	50 -0"003	14 -0"082	14 +0"052	15 +0"056	7				
ι Cygni	51 21	19 25	9:994	38 +0"040	7 -0"090	13 +0"042	10 +0"023	8				
3 Lacertæ	51 20	22 16	29:992	36 +0"025	8 +0"037	10 -0"016	13 -0"073	5				
1 π Cygni	50 22	21 35	42:781	31 -0"133	5 +0"068	9 +0"021	9 -0"015	8				
η Ursæ Maj.	50 13	13 40	26:243	43 +0"081	11 +0"015	10 -0"125	9 +0"007	11				
c Cyg. præc.	50 6	19 37	1:853	26 +0"026	7 -0"001	9 +0"023	6 -0"078	4				
— seq.	50 6	19 37	4:470	19 +0"034	4 -0"004	6 +0"019	6 -0"046	4				
θ Cygni	49 48	19 31	36:885	40 +0"090	7 -0"070	13 +0"012	12 +0"018	8				
α Persei	49 13	3 11	31:492	42 -0"056	11 -0"031	9 +0"011	9 +0"062	13				
1 ω Cygni	48 47	20 21	32:335	36 +0"113	10 -0"027	9 +0"035	9 -0"117	8				
δ Persei	47 12	3 30	9:272	13 +0"036	8 -0"023	5 —	—	—				
α Aurigæ	45 48	5 3	24:491	104 -0"025	36 -0"004	32 +0"008	17 +0"104	19				
ψ Ursæ Maj.	45 28	10 59	30:260	11 -0"023	6 +0"028	5 —	—	—				
α Cygni	44 39	20 35	17:921	69 -0"006	21 +0"007	21 +0"013	14 -0"022	13				
ι Aurigæ	43 33	4 49	4:415	32 -0"055	9 -0"110	4 +0"005	10 +0"100	9				
γ Andromed.	41 28	1 52	53:644	38 -0"114	9 +0"012	12 +0"109	9 +0"062	8				
η Aurigæ	40 59	4 53	54:881	38 -0"066	12 -0"116	6 +0"028	10 +0"122	10				
β Persei	40 15	2 56	54:581	38 -0"046	11 -0"017	9 -0"006	7 +0"132	11				
γ Cygni	39 41	20 15	46:298	33 +0"028	9 -0"017	9 +0"086	9 -0"143	6				
ι Persei	39 29	3 45	48:359	33 -0"056	10 +0"004	9 -0"024	8 +0"155	6				
η Herculis	39 16	16 36	43:850	32 -0"005	12 -0"036	8 +0"059	7 +0"081	5				
γ Bootis	39 6	14 24	49:736	26 +0"019	12 -0"076	7 +0"129	2 +0"061	5				
σ Cygni	38 38	21 10	21:217	26 +0"031	7 +0"008	9 +0"096	6 -0"247	4				

Besides this catalogue M. Argelander likewise computed the probable errors of the single observation of each star, and found them as follows:

	Declin.	Probable Errors.		Probable Errors. x. cos δ.	
		Upper Passage.	Lower Passage.	Upper Passage.	Lower Passage.
ζ Ursæ Min.	78 21	0 ^{''} 115	0 ^{''} 194	0 ^{''} 023	0 ^{''} 039
γ Cephei	76 37	0 ^{''} 147	0 ^{''} 225	0 ^{''} 034	0 ^{''} 052
β Ursæ Min.	74 54	0 ^{''} 131	0 ^{''} 106	0 ^{''} 034	0 ^{''} 028
γ —	72 29	0 ^{''} 140	0 ^{''} 145	0 ^{''} 042	0 ^{''} 044
κ Draconis	70 47	0 ^{''} 131	0 ^{''} 196	0 ^{''} 043	0 ^{''} 064
λ —	70 19	0 ^{''} 100	0 ^{''} 168	0 ^{''} 034	0 ^{''} 057
β Cephei	69 46	0 ^{''} 127	0 ^{''} 175	0 ^{''} 044	0 ^{''} 061
α Ursæ Maj.	62 43	0 ^{''} 085	0 ^{''} 123	0 ^{''} 039	0 ^{''} 056
η Draconis	61 55	0 ^{''} 102	0 ^{''} 094	0 ^{''} 048	0 ^{''} 044
α Cephei	61 49	0 ^{''} 084	0 ^{''} 174	0 ^{''} 040	0 ^{''} 082
66 Draconis	61 28	0 ^{''} 098	0 ^{''} 100	0 ^{''} 047	0 ^{''} 048
η Cephei	61 8	0 ^{''} 088	0 ^{''} 097	0 ^{''} 042	0 ^{''} 047
10 —	60 18	0 ^{''} 072	0 ^{''} 093	0 ^{''} 036	0 ^{''} 046
P. XX. 222	59 49	0 ^{''} 071	0 ^{''} 075	0 ^{''} 036	0 ^{''} 038
ο Draconis	59 10	0 ^{''} 080	0 ^{''} 128	0 ^{''} 042	0 ^{''} 066
θ —	59 3	0 ^{''} 109	0 ^{''} 084	0 ^{''} 056	0 ^{''} 043
2 Cephei Hev.	58 22	0 ^{''} 087	0 ^{''} 084	0 ^{''} 046	0 ^{''} 044
48 Draconis	57 35	0 ^{''} 092	0 ^{''} 179	0 ^{''} 049	0 ^{''} 096
δ Cephei	57 30	0 ^{''} 092	0 ^{''} 103	0 ^{''} 050	0 ^{''} 056
ζ —	57 19	0 ^{''} 088	0 ^{''} 129	0 ^{''} 048	0 ^{''} 070
53 Draconis	56 33	0 ^{''} 101	0 ^{''} 110	0 ^{''} 056	0 ^{''} 061
ι Cephei	56 9	0 ^{''} 119	0 ^{''} 107	0 ^{''} 066	0 ^{''} 060
33 Cygni	56 2	0 ^{''} 078	0 ^{''} 081	0 ^{''} 044	0 ^{''} 046
μ Cephei	55 46	0 ^{''} 074	0 ^{''} 122	0 ^{''} 042	0 ^{''} 069
α Cassiopeiæ	55 33	0 ^{''} 085	0 ^{''} 096	0 ^{''} 048	0 ^{''} 055
49 Draconis	55 24	0 ^{''} 095	0 ^{''} 104	0 ^{''} 054	0 ^{''} 059
P. XXI. 336	55 22	0 ^{''} 084	0 ^{''} 104	0 ^{''} 048	0 ^{''} 059
γ Draconis	55 21	0 ^{''} 094	—	0 ^{''} 054	—
υ Ursæ Maj.	54 42	0 ^{''} 092	0 ^{''} 145	0 ^{''} 053	0 ^{''} 084
P. XX. 391	53 50	0 ^{''} 081	0 ^{''} 099	0 ^{''} 047	0 ^{''} 059
51 Draconis	53 6	0 ^{''} 080	0 ^{''} 084	0 ^{''} 048	0 ^{''} 051
κ Cygni	53 2	0 ^{''} 088	0 ^{''} 105	0 ^{''} 053	0 ^{''} 064
P. XXI. 32	52 50	0 ^{''} 069	0 ^{''} 087	0 ^{''} 041	0 ^{''} 053
20 Cygni	52 32	0 ^{''} 092	0 ^{''} 096	0 ^{''} 056	0 ^{''} 058
β Draconis	52 26	0 ^{''} 088	0 ^{''} 132	0 ^{''} 054	0 ^{''} 081
γ —	51 31	0 ^{''} 101	0 ^{''} 118	0 ^{''} 063	0 ^{''} 073
ι Cygni	51 21	0 ^{''} 058	0 ^{''} 128	0 ^{''} 036	0 ^{''} 080
3 Lacertæ	51 20	0 ^{''} 092	0 ^{''} 074	0 ^{''} 051	0 ^{''} 047
1 π Cygni	50 22	0 ^{''} 108	0 ^{''} 120	0 ^{''} 069	0 ^{''} 077
η Ursæ Maj.	50 13	0 ^{''} 078	0 ^{''} 087	0 ^{''} 050	0 ^{''} 055
c Cyg. præc.	50 6	0 ^{''} 049	0 ^{''} 096	0 ^{''} 031	0 ^{''} 061
— seq.	50 6	0 ^{''} 102	0 ^{''} 119	0 ^{''} 065	0 ^{''} 076
θ —	49 18	0 ^{''} 064	0 ^{''} 094	0 ^{''} 042	0 ^{''} 062
α Persei	49 13	0 ^{''} 060	0 ^{''} 116	0 ^{''} 038	0 ^{''} 076
1 ω Cygni	48 47	0 ^{''} 035	0 ^{''} 087	0 ^{''} 036	0 ^{''} 055
δ Persei	47 12	0 ^{''} 063	—	0 ^{''} 043	—
α Aurigæ	45 48	0 ^{''} 059	0 ^{''} 085	0 ^{''} 041	0 ^{''} 059
ψ Ursæ Maj.	45 28	0 ^{''} 080	—	0 ^{''} 056	—
α Cygni	44 39	0 ^{''} 064	0 ^{''} 103	0 ^{''} 046	0 ^{''} 073
ι Aurigæ	43 33	0 ^{''} 086	0 ^{''} 087	0 ^{''} 063	0 ^{''} 063
γ Andromed.	41 28	0 ^{''} 087	0 ^{''} 113	0 ^{''} 065	0 ^{''} 085
η Aurigæ	40 59	0 ^{''} 067	0 ^{''} 067	0 ^{''} 050	0 ^{''} 050
β Persei	40 15	0 ^{''} 076	0 ^{''} 111	0 ^{''} 058	0 ^{''} 085
γ Cygni	39 41	0 ^{''} 070	0 ^{''} 068	0 ^{''} 054	0 ^{''} 052
ι Persei	39 29	0 ^{''} 074	0 ^{''} 112	0 ^{''} 057	0 ^{''} 087
η Herculis	39 16	0 ^{''} 087	0 ^{''} 136	0 ^{''} 067	0 ^{''} 105
γ Bootis	39 6	0 ^{''} 089	0 ^{''} 119	0 ^{''} 069	0 ^{''} 092
σ Cygni	38 39	0 ^{''} 087	0 ^{''} 114	0 ^{''} 068	0 ^{''} 089

The differences of the results obtained in the different positions of the circle and in both passages are commonly small, and easily to be reconciled with the probable errors above given. Differences amounting to a second of a great circle are, notwithstanding the frequently small number of observations, rare, and occur only about once in nineteen times at those altitudes where the proximity of the horizon has no influence on the observations: usually the differences go on without any regularity; but sometimes they appear to follow some law, *e. g.* from 60° to 80° declination, in the upper passage and eastern position of the circle. Its small amount, however, would render any further conclusions very difficult, especially as it can hardly be doubted that the errors arising from the instrument itself are mixed with others which are as yet unknown. I believe, therefore, that the severe test to which this instrument has been subjected, warrants the conclusion that the deviation of the line of collimation from a circle, if any exists, is too small to be determined by observations.

As a transit, this beautiful instrument completely fulfills every thing that can be required. It gives the right ascensions, whether the stars are observed above or below the pole, whether the circle is in its eastern or western position, by a comparison with the fundamental catalogue, with such a near agreement that no decided difference can be assigned.

7. Place of the Meridian Mark.

The same equations which were employed for determining the collimation, likewise give $15\Delta a$ or the eastern deviation of the mark from the meridian. I have determined it so as to compare every period with the preceding and following one.

	$15\Delta a$		$15\Delta a$
1820.		1820.	
May 27 to June 27	+2''16	Nov. 29 to Dec. 23	+1''15
June 12—July 16	+2'75	Dec. 29—Jan. 3	+2'41
June 29—Aug. 1	+2'07	1821.	
July 20—Aug. 9	+1'84	Jan. 12 to Feb. 28	+1'80
Aug. 1—Aug. 19	+1'99	Feb. 11—Mar. 25	+0'32
Aug. 9—Sept. 1	+1'61	Mar. 27—April 17	+2'32
Aug. 21—Sept. 16	+1'80	April 20—May 4	+3'58
Sept. 7—Oct. 4	+1'33	April 25—May 22	+1'89
Sept. 23—Oct. 27	+0'69	May 5—June 4	+1'43
Oct. 13—Nov. 15	+3'10	May 25—June 18	+1'29
		June 11—June 30	+1'12

The

The mean of all these twenty determinations is $+1''\cdot83$, exactly agreeing with the result obtained by Dollond's transit.

I have stated here the single results, as they may serve for solving the question, whether the axis of rotation of the earth coincides with a principal axis, for which there is, as far as I know, no positive proof founded on observation. If the period of the inequality resulting from this cause, on the supposition of the earth being a spheroid of rotation, be supposed = $337\cdot5$ mean days, and if the angle of the axis be designated by \mathfrak{S} , the observed azimuth of the mark is

$$= 15\Delta a + \mathfrak{S} \sec. \phi (\varepsilon + t. 1^{\circ} 4')$$

where t denotes the number of mean days elapsed from the beginning of 1820, and ε the value of the argument at that time. The twenty observations compared with this formula

give	$15 \Delta a = +1''\cdot804$	probable error	$= \pm 0''\cdot1226$
	$\mathfrak{S} \cdot \cos \varepsilon = +0\cdot064$		$= \pm 0\cdot0997$
	$\mathfrak{S} \cdot \sin \varepsilon = -0\cdot090$		$= \pm 0\cdot0927$
	$\mathfrak{S} = 0\cdot110$		$= \pm 0\cdot1361$

from which it becomes probable that the angle of the axis does not exceed a quarter of a second.

Observations of this kind, continued during a longer period or instituted with the sole view to determine \mathfrak{S} , might still more diminish the uncertainty; those which have here been given may, however, satisfy us that the angle of the axes is so small as to have no dangerous influence upon the greatest number of observations.

Besides these remarks concerning the use of the instrument as a transit, I have to give some explanations on the observations in general. The observations made with the circle may be employed either as polar distances or zenith distances according as the place of the pole or of the zenith on the instrument is supposed to be known; the former appears to me to be more direct, partly because the result which is required, the declination, is immediately derived from the polar distance, partly because the place of the pole may be found at every period independently of reversing the instrument; whereas the place of the zenith can only be determined by combining two periods. I have therefore constantly referred all computations hitherto made to the pole, and give here the determinations which have been employed, and which are exclusively founded on the two pole-stars which were usually observed five times at each passage; the declinations made use of in these calculations are for α *Ursæ Minoris* taken from the Ephemeris which Prof. Schumacher and Prof. Struve have published; for δ *Ursæ Minoris* they were computed from my tables.

	Star.	No. of Obs.	Place of the Pole on the Instrument.	Means.
1820.				
March 6—7	α U	5	$33^{\circ} 42' 58.17 - \delta$	} $33^{\circ} 42' 58.24$
	α L	5	$58.30 + \delta$	
7—8	α U	5	$323 \quad 8 \quad 40.07 + \delta$	} $323 \quad 8 \quad 39.52$
	α L	5	$38.98 - \delta$	
11	α L	2	$33 \quad 42 \quad 58.03 + \delta$	} $33 \quad 42 \quad 57.67$
16—17	α U	5	$33 \quad 43 \quad 1.04 - \delta$	} $33 \quad 43 \quad 1.40$
19—28	α U	17	$323 \quad 8 \quad 36.16 + \delta$	} $323 \quad 8 \quad 36.21$
	α L	3	$36.26 - \delta$	
April 5—7	α U	14	$33 \quad 42 \quad 52.48 - \delta$	} $33 \quad 42 \quad 52.83$
	α L	14	$53.18 + \delta$	
8—13	α U	41	$323 \quad 8 \quad 41.24 + \delta$	} $323 \quad 8 \quad 41.07$
	α L	13	$40.89 - \delta$	
13—17	α U	21	$33 \quad 42 \quad 57.51 - \delta$	} $33 \quad 42 \quad 57.39$
	α L	19	$57.27 + \delta$	
18—21	α U	9	$33 \quad 42 \quad 59.64 - \delta$	} $33 \quad 42 \quad 59.46$
	L	10	$59.28 + \delta$	
22—26	α U	27	$323 \quad 8 \quad 43.77 + \delta$	} $323 \quad 8 \quad 43.33$
	L	19	$42.89 - \delta$	
27—33	α U	35	$33 \quad 42 \quad 59.65 - \delta$	} $33 \quad 43 \quad 0.08$
	α L	22	$60.51 + \delta$	
May 4—15	α U	51	$323 \quad 8 \quad 44.09 + \delta$	} $323 \quad 8 \quad 43.41$
	α L	37	$42.73 - \delta$	
15—25	α U	42	$33 \quad 42 \quad 58.59 - \delta$	} $33 \quad 42 \quad 59.03$
	L	21	$59.46 + \delta$	
27—42	α U	16	$323 \quad 8 \quad 42.19 + \delta$	} $323 \quad 8 \quad 41.50$
	α L	27	$40.80 - \delta$	
June 12—27	α U	48	$33 \quad 42 \quad 58.03 - \delta$	} $33 \quad 42 \quad 57.86$
	α L	37	$57.68 + \delta$	
29—46	α U	12	$323 \quad 8 \quad 41.99 + \delta$	} $323 \quad 8 \quad 41.27$
	α L	37	$40.54 - \delta$	
	δ U	9	$41.39 + \delta'$	} $323 \quad 8 \quad 41.27$
	δ L	5	$40.77 - \delta'$	
July 17—32	α L	35	$33 \quad 42 \quad 58.48 + \delta$	} $33 \quad 42 \quad 58.17$
	δ U	17	$58.35 - \delta'$	
	L	5	$58.11 + \delta'$	} $323 \quad 8 \quad 40.18$
Aug. 1—9	α L	20	$323 \quad 8 \quad 39.78 - \delta$	
	δ U	16	$39.57 + \delta'$	} $323 \quad 8 \quad 40.18$
	L	19	$40.79 - \delta'$	
9—19	L	20	$33 \quad 42 \quad 57.67 + \delta$	} $33 \quad 42 \quad 57.90$
	δ U	17	$59.01 - \delta'$	
	L	7	$57.87 + \delta'$	

Aug.

Aug. 21—38	α L	20	323 8	40·34— δ	} 323 8 40·89			
	δ U	25		40·50+ δ'				
	L	12		40·69— δ'				
Sept. 7—16	α U	25	33 42	58·83— δ	} 33 42 58·52			
	L	25		58·10+ δ				
	δ U	10		58·67— δ'				
	L	10		58·65+ δ'				
	22—34	α U		26		323 8	41·64+ δ	} 323 8 41·09
		L		29			40·54— δ	
Oct. 12—32	α U	15	33 42	59·84— δ	} 33 42 59·66			
	L	27		59·49+ δ				
Nov. 4—15	α U	15	323 8	43·69+ δ	} 323 8 42·95			
	L	5		42·21— δ				
Nov. 26—46	α U	37	323 8	31·62+ δ	} 323 8 32·12			
	L	46		32·62— δ				
Dec. 16—25	α U	43	33 42	50·46— δ	} 33 42 50·71			
	L	32		50·96+ δ				
29—34	α U	22	323 8	28·89+ δ	} 323 8 29·33			
	δ U	8		31·10+ δ'				
	L	12		29·08— δ'				

It appears from these results that the place of the pole or the instrument, whenever it had undergone no change, is subject to very small variations, which in the course of each period always appeared insensible. In order to trace, however, likewise these small inequalities, I have noted down for some months the state of a thermometer attached to the pillars, and the length of the air-bubble of the level of the altitude in the last column of the observations, *e. g.* No. 4 bubble 63·6 = 7°·6; but when I found no connexion, I did not continue this practice any further. The instrument got repeatedly new wires, the intervals between which are stated in the observations. At the passage of the sun the first limb was usually observed on the first four, and the following limb on the last three or four wires; in the mean time the northern or southern limb was brought between the horizontal wires, and the circle read off. There is only time to do this if the observation by the circle is made 20" or 30" before the culmination, and two verniers only are read off. For this purpose it becomes necessary to know the deviation of the horizontal wires from parallelism to the equator, and the difference of two verniers from four. The former was investigated by means of observing α *Ursæ Minoris* at the two extremities, and in the middle of the system of wires. By this means the corrections to be applied to the readings of the circle to correct this error, were found as follow:

From

From March 27 to April 7	$\mp 0^{\circ}00'40$	$t. \cos \delta$
April 8 — May 19	$\pm 0^{\circ}02'26$	$t. \cos \delta$
May 23 — May 25	$\pm 0^{\circ}05'51$	$t. \cos \delta$
May 27 — Nov. 14	$\mp 0^{\circ}00'97$	$t. \cos \delta$
Dec. 1 — Dec. 31	$\pm 0^{\circ}01'09$	$t. \cos \delta$

where t denotes the number of seconds before the culmination; and the upper sign is to be applied for the eastern, the lower one for the western position of the circle.

The same observations have decided that gravity does not act on the horizontal wires; for the observations made at the two extremities, and reduced to the meridian, always very nearly agreed with those made in the middle; and the mean of the frequent trials of this kind, occurring in the journal, do not show the least trace of a flexure by gravity.

The difference of two verniers from four I have determined by a set of readings, which were repeated three times, and freed from the effect which the temperature might produce by acting unequally on the circle and the alidade, by allowing always at least half an hour to elapse between the placing and reading off of the circle.

Vernier I.	II.	III.	IV.	$\frac{1}{2}(I+III)$	$\frac{1}{2}(II+IV)$	Semi-Difference.
0 0 0	+5 ^{''} 65	+5 ^{''} 15	+2 ^{''} 65	+2 ^{''} 63	+4 ^{''} 15	+0 ^{''} 76
15 0 0	+1 ^{''} 8	+1 ^{''} 31	+1 ^{''} 35	+0 ^{''} 65	+1 ^{''} 58	+0 ^{''} 47
30 0 0	+0 ^{''} 65	-0 ^{''} 85	+0 ^{''} 15	-0 ^{''} 43	+0 ^{''} 40	+0 ^{''} 41
45 0 0	+2 ^{''} 5	+0 ^{''} 55	+2 ^{''} 25	+0 ^{''} 28	+2 ^{''} 38	+1 ^{''} 05
60 0 0	+0 ^{''} 85	-1 ^{''} 7	-0 ^{''} 7	-0 ^{''} 85	+0 ^{''} 08	+0 ^{''} 47
75 0 0	+2 ^{''} 55	-2 ^{''} 1	-0 ^{''} 25	-1 ^{''} 05	+1 ^{''} 15	+1 ^{''} 10
90 0 0	+6 ^{''} 55	-0 ^{''} 4	-0 ^{''} 4	-0 ^{''} 20	+3 ^{''} 08	+1 ^{''} 64
105 0 0	+8 ^{''} 75	+3 ^{''} 7	+3 ^{''} 1	+1 ^{''} 85	+5 ^{''} 93	+2 ^{''} 04
120 0 0	+6 ^{''} 25	+2 ^{''} 75	+4 ^{''} 6	+1 ^{''} 38	+5 ^{''} 43	+2 ^{''} 03
135 0 0	+5 ^{''} 8	+2 ^{''} 35	+2 ^{''} 9	+1 ^{''} 18	+4 ^{''} 35	+1 ^{''} 59
150 0 0	+6 ^{''} 3	+1 ^{''} 95	+4 ^{''} 5	+0 ^{''} 98	+5 ^{''} 40	+2 ^{''} 21
165 0 0	+3 ^{''} 0	-0 ^{''} 4	+0 ^{''} 2	-0 ^{''} 20	+1 ^{''} 60	+0 ^{''} 90
180 0 0	+3 ^{''} 2	-2 ^{''} 6	-1 ^{''} 45	-1 ^{''} 30	+0 ^{''} 88	+1 ^{''} 09
195 0 0	+4 ^{''} 5	-1 ^{''} 0	-2 ^{''} 25	-0 ^{''} 50	+1 ^{''} 13	+0 ^{''} 82
210 0 0	+4 ^{''} 0	+0 ^{''} 35	-1 ^{''} 7	+0 ^{''} 18	+1 ^{''} 15	+0 ^{''} 49
225 0 0	+4 ^{''} 0	+0 ^{''} 6	-0 ^{''} 25	+0 ^{''} 30	+1 ^{''} 88	+0 ^{''} 79
240 0 0	+4 ^{''} 1	-0 ^{''} 65	-1 ^{''} 65	-0 ^{''} 33	+1 ^{''} 23	+0 ^{''} 78
255 0 0	+4 ^{''} 0	-0 ^{''} 1	+1 ^{''} 45	-0 ^{''} 05	+2 ^{''} 73	+1 ^{''} 39
270 0 0	+4 ^{''} 1	-0 ^{''} 15	+3 ^{''} 1	-0 ^{''} 08	+3 ^{''} 60	+1 ^{''} 84
285 0 0	+2 ^{''} 8	-3 ^{''} 7	+2 ^{''} 05	-1 ^{''} 85	+2 ^{''} 43	+2 ^{''} 14
300 0 0	+4 ^{''} 25	-3 ^{''} 05	+0 ^{''} 45	-1 ^{''} 53	+2 ^{''} 35	+1 ^{''} 94
315 0 0	+3 ^{''} 3	-1 ^{''} 85	+0 ^{''} 25	-0 ^{''} 93	+1 ^{''} 78	+1 ^{''} 36
330 0 0	+4 ^{''} 85	-1 ^{''} 75	+1 ^{''} 35	-0 ^{''} 88	+3 ^{''} 10	+1 ^{''} 99
345 0 0	+3 ^{''} 85	-0 ^{''} 25	-0 ^{''} 4	-0 ^{''} 13	+1 ^{''} 73	+0 ^{''} 93

The semi-differences contained in the last column are to be applied to the readings obtained by the first and third verniers with their signs: but to those obtained by the second and fourth verniers with the contrary signs. They are well represented by the formula $+ 1''\cdot26 + 0''\cdot6764 \sin \{2u + 215^\circ 66\}$ where u denotes the reading of the first vernier. The values of this formula have been constantly applied to the observations of the sun being added together with the deviation of the wires from the parallelism, the deviation of the parallel from a great circle, and the change of declination in the column of the journal headed, *Reduction to the Meridian*. The numbers for the two pole-stars contained in the same column, however, do not include the deviation of the horizontal wires,

During the observations of the sun the whole instrument was screened, and only two inches of the object-glass were left uncovered. But, notwithstanding this, as a considerable degree of heat was produced in the focus, I applied, on the 25th of November 1820, near the place of the wires, a stop made of thin brass plate, which completely protects the ring containing the wires from the rays of the sun.

The divisions of the level of the alhidade circle were determined by changing, in some culminations of the pole-star, the alhidade at each observation; the value of a Paris line on the scale was thus found:

1820.	April	11	1'' ² 36	Therm. =	-11 ^o 2 C.
		12	1'' ² 55	14 ^o 4
		14	1'' ² 91	14 ^o 25
		20	1'' ² 54	8 ^o 3
	June	27	1'' ¹ 82	19 ^o 3
1821.	May	22	1'' ² 27	10 ^o 0
Mean . . .			1'' ² 41		

This value has been used to convert the deviation of the level given at each observation into seconds. Whenever the alhidade began to show somewhat considerable deviations, I put it back by the screw of the alhidade; in the beginning this has not been mentioned in the journal, but since the 11th of December, 1820, I have always remarked it whenever I have touched the screw.

This level has the inconvenience of having the bubble in our winters extended to such a length that its extremities are covered, and can no longer be observed. In order to avoid the adding of spirit, I have filled the lower part of the tube to about its axis with closed glass tubes, so that it takes only half the quantity of spirit of wine, and consequently shows only half the effects of temperature, and may now be used without alteration all the year round.

Tables for δ Ursæ Minoris.

1815	-0.736	460	D	Dorpat.....	-0.068
1816	-0.978	+0.022	828		Göttingen..	-0.021
1817	-0.220	196		Gotha.....	-0.023
1818	-0.462	565		Greenwich..	+0.006
1819	-0.704	933		Königsberg	-0.050
1820	-0.947	+0.053	301		Mannheim..	-0.017
1821	-0.189	669		Milan.....	-0.019
1822	-0.432	37		Munich....	-0.026
1823	-0.674	406		Palermo....	-0.031
1824	-0.917	+0.083	774		Paris.....	0.000
1825	-0.159	143		Vienna.....	-0.039
1826	-0.401	511			

Argument.—1. For the upper passage,

+1 *d.* until December 28.

+2 *d.* from December 28 to December 31.

2. For the lower passage,

+0.5 *d.* until June 28.

+1.5 *d.* from June 28 to December 31.

Sum of the mean Position for the Beginning of the Years and of the Nutation.

1815.	Jan. 0	^h 18 32' 0".56	- 1	86° 34' 29".04	-83
	April 10	0".55	- 7	28.21	-82
	July 19	0".48	-13	27.39	-81
	Oct. 27	0".35	-18	26.58	-81
	Dec. 66	0".17		25.77	
1816.	Jan. 0	18 31 41.19	-21	86 34 28.81	-80
	April 10	40.98	-26	28.01	-76
	July 19	40.72	-31	27.25	-73
	Oct. 27	40.41	-35	26.52	-69
	Dec. 66	40.06		25.83	
1817.	Jan. 0	18 31 21.13	-39	86 34 28.80	-68
	April 10	20.74	-42	28.12	-62
	July 19	20.32	-46	27.50	-57
	Oct. 27	19.86	-50	26.93	-52
	Dec. 66	19.36		26.41	
1818.	Jan. 0	18 31 0.48	-52	86 34 29.31	-48
	April 10	30 59.96	-53	28.83	-41
	July 19	59.43	-55	28.42	-35
	Oct. 27	58.88	-57	28.07	-28
	Dec. 66	58.31		27.79	

1819.	Jan. 0	h 18 30' 39.43	-58	86 34' 30.56	-24
	April 10	38.85	-59	30.32	-16
	July 19	38.26	-59	30.16	-9
	Oct. 27	37.67	-60	30.07	-2
	Dec. 66	37.07		30.05	
1820.	Jan. 0	18 30 18.19	-60	86 34 32.70	+3
	April 10	17.59	-57	32.73	+10
	July 19	17.02	-56	32.83	+17
	Oct. 27	16.46	-55	33.00	+25
	Dec. 66	15.91		33.25	
1821.	Jan. 0	18 29 57.00	-53	86 34 35.78	+29
	April 10	56.47	-50	36.07	+36
	July 19	55.97	-47	36.43	+42
	Oct. 27	55.50	-44	36.85	+48
	Dec. 66	55.06		37.33	
1822.	Jan. 0	18 29 36.11	-41	86 34 39.76	+54
	April 10	35.70	-37	40.30	+57
	July 19	35.33	-33	40.87	+62
	Oct. 27	35.00	-29	41.49	+65
	Dec. 66	34.71		42.14	
1823.	Jan. 0	18 29 15.70	-25	86 34 44.49	+69
	April 10	15.45	-20	45.18	+73
	July 19	15.25	-15	45.91	+76
	Oct. 27	15.10	-9	46.67	+79
	Dec. 66	15.01		47.46	
1824.	Jan. 0	18 28 55.92	-5	86 34 49.74	+80
	April 10	55.87	0	50.54	+81
	July 19	55.87	+5	51.35	+81
	Oct. 27	55.92	+11	52.16	+82
	Dec. 66	56.03		52.98	
1825.	Jan. 0	28 28 36.87	+15	86 34 55.22	+82
	April 10	37.02	+19	56.04	+80
	July 19	37.21	+25	56.84	+78
	Oct. 27	37.46	+29	57.62	+77
	Dec. 66	37.75		58.39	
1826.	Jan. 0	18 20 18.51	+33	86 35 0.63	+74
	April 10	18.84	+37	1.37	+70
	July 19	19.21	+41	2.07	+67
	Oct. 27	19.62	+46	2.73	+62
	Dec. 66	20.08		3.35	

		Right Ascension.			Declination.			Aberration.		
		for 1820.	Diff.	Annual Variation.	for 1820.	Diff.	Annual Variation.	D	R.	Declin.
Jan.	0	-22 ^u .64	-0 ^u .15	-0 ^u .0048	-0 ^u .10	-1 ^u .69	-0 ^u .0282	0	-22 ^u .6	-0 ^u .6
	5	-22 ^u .79	+0 ^u .04	-0 ^u .0023	-1 ^u .79	-1 ^u .67	-0 ^u .0284	183	-22 ^u .4	-2 ^u .3
	10	-22 ^u .75	+0 ^u .22	+0 ^u .0003	-3 ^u .46	-1 ^u .66	-0 ^u .0285	365	-22 ^u .0	-4 ^u .0
	15	-22 ^u .53	+0 ^u .39	+0 ^u .0028	-5 ^u .12	-1 ^u .63	-0 ^u .0284	548	-21 ^u .4	-5 ^u .6
	20	-22 ^u .14	+0 ^u .59	+0 ^u .0053	-6 ^u .75	-1 ^u .58	-0 ^u .0279	730	-20 ^u .7	-7 ^u .2
Feb.	25	-21 ^u .55	+0 ^u .71	+0 ^u .0078	-8 ^u .33	-1 ^u .52	-0 ^u .0272	913	-19 ^u .8	-8 ^u .7
	30	-20 ^u .84	+0 ^u .89	+0 ^u .0103	-9 ^u .85	-1 ^u .44	-0 ^u .0263	95	-18 ^u .8	-10 ^u .2
	4	-19 ^u .95	+1 ^u .04	+0 ^u .0127	-11 ^u .29	-1 ^u .35	-0 ^u .0252	278	-17 ^u .7	-11 ^u .6
	9	-18 ^u .91	+1 ^u .18	+0 ^u .0150	-12 ^u .64	-1 ^u .25	-0 ^u .0240	460	-16 ^u .4	-12 ^u .9
	14	-17 ^u .73	+1 ^u .31	+0 ^u .0171	-13 ^u .89	-1 ^u .13	-0 ^u .0226	643	-15 ^u .0	-14 ^u .0
March	19	-16 ^u .42	+1 ^u .42	+0 ^u .0191	-15 ^u .02	-1 ^u .00	-0 ^u .0210	825	-13 ^u .4	-15 ^u .1
	24	-15 ^u .00	+1 ^u .51	+0 ^u .0209	-16 ^u .02	-0 ^u .87	-0 ^u .0193	8	-11 ^u .7	-16 ^u .0
	1	-13 ^u .49	+1 ^u .60	+0 ^u .0226	-16 ^u .89	-0 ^u .72	-0 ^u .0174	190	-10 ^u .0	-16 ^u .9
	6	-11 ^u .89	+1 ^u .66	+0 ^u .0240	-17 ^u .61	-0 ^u .58	-0 ^u .0154	373	-8 ^u .2	-17 ^u .6
	11	-10 ^u .23	+1 ^u .72	+0 ^u .0253	-18 ^u .19	-0 ^u .42	-0 ^u .0134	555	-6 ^u .4	-18 ^u .2
April	16	-8 ^u .51	+1 ^u .74	+0 ^u .0263	-18 ^u .61	-0 ^u .27	-0 ^u .0113	738	-4 ^u .5	-18 ^u .6
	21	-6 ^u .77	+1 ^u .76	+0 ^u .0271	-18 ^u .88	-0 ^u .11	-0 ^u .0092	920	-2 ^u .5	-18 ^u .9
	26	-5 ^u .01	+1 ^u .76	+0 ^u .0276	-18 ^u .99	+0 ^u .05	-0 ^u .0070	103	-0 ^u .5	-19 ^u .0
	31	-3 ^u .25	+1 ^u .74	+0 ^u .0279	-18 ^u .94	+0 ^u .20	-0 ^u .0048	285	+1 ^u .4	-19 ^u .0
	5	-1 ^u .51	+1 ^u .71	+0 ^u .0280	-18 ^u .74	+0 ^u .36	-0 ^u .0027	468	+3 ^u .3	-18 ^u .9
May	10	+0 ^u .20	+1 ^u .65	+0 ^u .0278	-18 ^u .38	+0 ^u .51	-0 ^u .0006	650	+5 ^u .2	-18 ^u .6
	15	+1 ^u .85	+1 ^u .60	+0 ^u .0275	-17 ^u .87	+0 ^u .65	+0 ^u .0014	833	+7 ^u .0	-18 ^u .2
	20	+3 ^u .45	+1 ^u .51	+0 ^u .0268	-17 ^u .22	+0 ^u .78	+0 ^u .0034	15	+8 ^u .8	-17 ^u .7
	25	+4 ^u .96	+1 ^u .42	+0 ^u .0257	-16 ^u .44	+0 ^u .91	+0 ^u .0052	198	+10 ^u .5	-17 ^u .0
	30	+6 ^u .38	+1 ^u .32	+0 ^u .0245	-15 ^u .53	+1 ^u .03	+0 ^u .0069	380	+12 ^u .2	-16 ^u .2
June	5	+7 ^u .70	+1 ^u .21	+0 ^u .0234	-14 ^u .50	+1 ^u .14	+0 ^u .0085	563	+13 ^u .7	-15 ^u .3
	10	+8 ^u .91	+1 ^u .08	+0 ^u .0221	-13 ^u .56	+1 ^u .23	+0 ^u .0100	745	+15 ^u .2	-14 ^u .3
	15	+9 ^u .99	+0 ^u .95	+0 ^u .0205	-12 ^u .13	+1 ^u .32	+0 ^u .0112	928	+16 ^u .6	-13 ^u .2
	20	+10 ^u .94	+0 ^u .81	+0 ^u .0186	-10 ^u .81	+1 ^u .40	+0 ^u .0123	110	+17 ^u .8	-12 ^u .0
	25	+11 ^u .75	+0 ^u .66	+0 ^u .0167	-9 ^u .41	+1 ^u .46	+0 ^u .0132	293	+18 ^u .9	-10 ^u .7
July	30	+12 ^u .41	+0 ^u .52	+0 ^u .0146	-7 ^u .95	+1 ^u .51	+0 ^u .0140	475	+19 ^u .8	-9 ^u .4
	4	+12 ^u .93	+0 ^u .36	+0 ^u .0124	-6 ^u .44	+1 ^u .56	+0 ^u .0146	658	+20 ^u .7	-8 ^u .0
	9	+13 ^u .29	+0 ^u .21	+0 ^u .0101	-4 ^u .88	+1 ^u .59	+0 ^u .0150	840	+21 ^u .4	-6 ^u .5
	14	+13 ^u .50	+0 ^u .05	+0 ^u .0077	-3 ^u .29	+1 ^u .60	+0 ^u .0152	23	+21 ^u .9	-5 ^u .0
	19	+13 ^u .55	-0 ^u .11	+0 ^u .0053	-1 ^u .69	+1 ^u .61	+0 ^u .0152	205	+22 ^u .3	-3 ^u .5
August	24	+13 ^u .44	-0 ^u .26	+0 ^u .0028	-0 ^u .08	+1 ^u .61	+0 ^u .0150	388	+22 ^u .5	-1 ^u .9
	29	+13 ^u .18	-0 ^u .42	+0 ^u .0003	+1 ^u .53	+1 ^u .60	+0 ^u .0146	570	+22 ^u .6	-0 ^u .3
	4	+12 ^u .76	-0 ^u .56	-0 ^u .0022	+3 ^u .13	+1 ^u .57	+0 ^u .0140	753	+22 ^u .5	+1 ^u .3
	9	+12 ^u .20	-0 ^u .72	-0 ^u .0047	+4 ^u .70	+1 ^u .54	+0 ^u .0132	935	+22 ^u .3	+2 ^u .8
	14	+11 ^u .48	-0 ^u .86	-0 ^u .0072	+6 ^u .24	+1 ^u .50	+0 ^u .0122	118	+21 ^u .9	+4 ^u .4
Sept.	19	+10 ^u .62	-1 ^u .01	-0 ^u .0097	+7 ^u .74	+1 ^u .44	+0 ^u .0111	300	+21 ^u .3	+5 ^u .9
	24	+9 ^u .61	-1 ^u .13	-0 ^u .0121	+9 ^u .18	+1 ^u .39	+0 ^u .0098	483	+20 ^u .6	+7 ^u .4
	29	+8 ^u .48	-1 ^u .26	-0 ^u .0145	+10 ^u .57	+1 ^u .32	+0 ^u .0083	665	+19 ^u .8	+8 ^u .8
	3	+7 ^u .22	-1 ^u .39	-0 ^u .0168	+11 ^u .89	+1 ^u .25	+0 ^u .0067	848	+18 ^u .9	+10 ^u .2
	8	+5 ^u .83	-1 ^u .49	-0 ^u .0190	+13 ^u .12	+1 ^u .17	+0 ^u .0049	30	+17 ^u .8	+11 ^u .5
Sept.	13	+4 ^u .34	-1 ^u .60	-0 ^u .0211	+14 ^u .31	+1 ^u .09	+0 ^u .0030	213	+16 ^u .6	+12 ^u .7
	18	+2 ^u .74	-1 ^u .70	-0 ^u .0231	+15 ^u .40	+0 ^u .99	+0 ^u .009	395	+15 ^u .2	+13 ^u .9
	23	+1 ^u .04	-1 ^u .78	-0 ^u .0250	+16 ^u .39	+0 ^u .89	-0 ^u .0013	578	+13 ^u .7	+14 ^u .9
	28	+0 ^u .74	-1 ^u .87	-0 ^u .0268	+17 ^u .28	+0 ^u .79	-0 ^u .0035	760	+12 ^u .2	+15 ^u .9
	2	-2 ^u .61	-1 ^u .93	-0 ^u .0284	+18 ^u .07	+0 ^u .69	-0 ^u .0059	943	+10 ^u .5	+16 ^u .7

		Right Ascension.			Declination.			Aberration.		
		for 1820.	Diff.	Annual Variation.	for 1820.	Diff.	Annual Variation.	☾	R.	Declin.
Sept.	7	- 4.54	-1.99	-0.0299	+18.76	+0.57	-0.0083	125	+ 8.8	+17.4
	12	- 6.53	-2.04	-0.0312	+19.33	+0.47	-0.0108	308	+ 7.0	+18.0
	17	- 8.57	-2.07	-0.0323	+19.80	+0.34	-0.0134	490	+ 5.2	+18.5
	22	-10.64	-2.11	-0.0333	+20.14	+0.23	-0.0160	673	+ 3.3	+18.8
	27	-12.75	-2.11	-0.0342	+20.37	+0.10	-0.0187	855	+ 1.4	+19.0
Oct.	2	-14.86	-2.12	-0.0348	+20.47	-0.02	-0.0213	38	- 0.5	+19.0
	7	-16.98	-2.11	-0.0352	+20.45	-0.15	-0.0240	220	- 2.5	+19.0
	12	-19.09	-2.09	-0.0355	+20.30	-0.27	-0.0267	403	- 4.4	+18.8
	17	-21.18	-2.05	-0.0356	+20.03	-0.39	-0.0293	585	- 6.3	+18.4
	22	-23.23	-2.01	-0.0354	+19.64	-0.52	-0.0319	768	- 8.2	+17.9
Nov.	27	-25.24	-1.94	-0.0350	+19.12	-0.64	-0.0344	950	-10.0	+17.3
	1	-27.18	-1.88	-0.0345	+18.48	-0.77	-0.0369	133	-11.7	+16.5
	6	-29.06	-1.79	-0.0338	+17.71	-0.88	-0.0393	315	-13.3	+15.6
	11	-30.85	-1.69	-0.0328	+16.83	-1.00	-0.0415	498	-14.8	+14.5
	16	-32.54	-1.59	-0.0317	+15.83	-1.11	-0.0437	680	-16.3	+13.4
Dec.	21	-34.13	-1.47	-0.0305	+14.72	-1.21	-0.0457	863	-17.6	+12.2
	26	-35.60	-1.33	-0.0290	+13.51	-1.30	-0.0476	45	-18.8	+10.9
	1	-36.93	-1.19	-0.0272	+12.21	-1.39	-0.0493	228	-19.8	+ 9.5
	6	-38.12	-1.04	-0.0253	+10.82	-1.47	-0.0509	410	-20.7	+ 8.0
	11	-39.16	-0.89	-0.0233	+ 9.35	-1.54	-0.0522	593	-21.4	+ 6.4
	16	-40.05	-0.71	-0.0212	+ 7.81	-1.59	-0.0534	775	-22.0	+ 4.8
	21	-40.76	-0.54	-0.0190	+ 6.22	-1.63	-0.0544	958	-22.4	+ 3.2
	26	-41.30	-0.37	-0.0166	+ 4.59	-1.67	-0.0551	140	-22.6	+ 1.5
	31	-41.67	-0.19	-0.0141	+ 2.92	-1.68	-0.0556	323	-22.5	- 0.2
	36	-41.86		-0.0116	+ 1.24		-0.0559	505	-22.4	- 1.9

Lunar Perturbation.

		R.	Decl.			R.	Decl.
0	500	-0.01	-0.09	250	750	+0.01	+0.09
10	510	0.00	-0.09	260	760	0.00	+0.09
20	520	+0.01	-0.09	270	770	-0.01	+0.09
30	530	+0.02	-0.08	280	780	-0.02	+0.08
40	540	+0.03	-0.08	290	790	-0.03	+0.08
50	550	+0.03	-0.08	300	800	-0.03	+0.08
60	560	+0.04	-0.07	310	810	-0.04	+0.07
70	570	+0.05	-0.06	320	820	-0.05	0.06
80	580	+0.06	-0.06	330	830	-0.06	+0.06
90	590	+0.06	-0.05	340	840	-0.06	+0.05
100	600	+0.07	-0.04	350	850	-0.07	+0.04
110	610	+0.07	-0.03	360	860	-0.07	+0.03
120	620	+0.08	-0.02	370	870	-0.08	+0.02
130	630	+0.08	-0.01	380	880	-0.08	+0.01
140	640	+0.08	+0.01	390	890	-0.08	-0.01
150	650	+0.08	+0.02	400	900	-0.08	-0.02
160	660	+0.07	+0.03	410	910	-0.07	-0.03
170	670	+0.07	+0.04	420	920	-0.07	-0.04
180	680	+0.07	+0.05	430	930	-0.07	-0.05
190	690	+0.06	+0.06	440	940	-0.06	-0.06
200	700	+0.06	+0.06	450	950	-0.06	-0.06
210	710	+0.05	+0.07	460	960	-0.05	-0.07
220	720	0.04	+0.08	470	970	-0.04	-0.08
230	730	+0.03	+0.08	480	980	-0.03	-0.08
240	740	+0.02	+0.08	490	990	-0.02	-0.08
				500	0	-0.01	-0.09

IV. *On the Corrosion of Copper Sheeting by Sea-Water, and on Methods of preventing this Effect; and on their Application to Ships of War and other Ships.* By Sir HUMPHRY DAVY, Bart. Pres. R.S.*

1. **T**HE rapid decay of the copper sheeting of His Majesty's ships of war, and the uncertainty of the time of its duration, have long attracted the attention of those persons most concerned in the naval interests of the country. Having had my inquiries directed to this important object by the Commissioners of the Navy Board, and a Committee of the Royal Society having been appointed to consider of it, I entered into an experimental investigation of the causes of the action of sea-water upon copper. In pursuing this investigation, I have ascertained many facts which I think not unworthy of the notice of the Royal Society, as they promise to illustrate some obscure parts of electro-chemical science; and likewise seem to offer important practical applications.

2. It has been generally supposed that sea-water had little or no action on pure copper, and that the rapid decay of the copper on certain ships was owing to its impurity. On trying, however, the action of sea-water upon two specimens of copper, sent by John Vivian, Esq. to Mr. Faraday for analysis, I found the specimen which appeared absolutely pure, was acted upon even more rapidly than the specimen which contained alloy: and, on pursuing the inquiry with specimens of various kinds of copper which had been collected by the Navy Board, and sent to the Royal Society, and some of which had been considered as remarkable for their durability, and others for their rapid decay, I found that they offered very inconsiderable differences only in their action upon sea-water; and, consequently, that the changes they had undergone must have depended upon other causes than the absolute quality of the metal.

3. To enable persons to understand fully the train of these researches, it will be necessary for me to describe the nature of the chemical changes taking place in the constituents of sea-water by the agency of copper.

When a piece of polished copper is suffered to remain in sea-water, the first effects observed are, a yellow tarnish upon the copper, and a cloudiness in the water, which take place in two or three hours: the hue of the cloudiness is at first white; it gradually becomes green. In less than a day a blueish-green precipitate appears in the bottom of the vessel,

* From the Philosophical Transactions for 1824, Part I.

which constantly accumulates; at the same time that the surface of the copper corrodes, appearing red in the water, and grass-green where it is in contact with air. Gradually carbonate of soda forms upon this grass-green matter; and these changes continue till the water becomes much less saline.

The green precipitate, when examined by the action of solution of ammonia and other tests, appears principally to consist of an insoluble compound of copper (which may be considered as a hydrated sub-muriate) and hydrate of magnesia.

According to the views which I developed fourteen years ago, of the nature of the compounds of chlorine, and which are now generally adopted, it is evident that soda and magnesia cannot appear in sea-water by the action of a metal, unless in consequence of an absorption or transfer of oxygen. It was therefore necessary for these changes, either that water should be decomposed, or oxygen absorbed from the atmosphere. I found that no hydrogen was disengaged, and consequently no water decomposed: necessarily, the oxygen of the air must have been the agent concerned, which was made evident by many experiments.

Copper in sea-water deprived of air by boiling or exhaustion, and exposed in an exhausted receiver or an atmosphere of hydrogen gas, underwent no change; and an absorption in atmospherical air was shown when copper and sea-water were exposed to its agency in close vessels.

4. In the Bakerian Lecture for 1806, I have advanced the hypothesis, that chemical and electrical changes may be identical, or dependent upon the same property of matter; and I have further explained and illustrated this hypothesis in an elementary work on Chemistry published in 1812. Upon this view, which has been adopted by M. Berzelius and some other philosophers, I have shown that chemical attractions may be exalted, modified, or destroyed, by changes in the electrical states of bodies; that substances will only combine when they are in different electrical states; and that, by bringing a body naturally positive artificially into a negative state, its usual powers of combination are altogether destroyed; and it was by an application of this principle that in 1807 I separated the bases of the alkalis from the oxygen with which they are combined, and preserved them for examination; and decomposed other bodies formerly supposed to be simple.

It was in reasoning upon this general hypothesis likewise, that I was led to the discovery which is the subject of this paper.

Copper is a metal only weakly positive in the electro-chemical scale; and, according to my ideas, it could only act upon

upon sea-water when in a positive state; and, consequently, if it could be rendered slightly negative, the corroding action of sea-water upon it would be null; and whatever might be the differences of the kinds of copper sheeting and their electrical action upon each other, still every effect of chemical action must be prevented, if the whole surface were rendered negative. But how was this to be effected? I at first thought of using a Voltaic battery; but this could be hardly applicable in practice. I next thought of the contact of zinc, tin, or iron: but I was for some time prevented from trying this, by the recollection that the copper in the Voltaic battery, as well as the zinc, is dissolved by the action of diluted nitric acid; and by the fear that too large a mass of oxidable metal would be required to produce decisive results. After reflecting, however, for some time on the slow and weak action of sea-water on copper, and the small difference which must exist between their electrical powers; and knowing that a very feeble chemical action would be destroyed by a very feeble electrical force, I resolved to try some experiments on the subject. I began with an extreme case. I rendered sea-water slightly acidulous by sulphuric acid, and plunged into it a polished piece of copper, to which a piece of tin was soldered equal to about one-twentieth of the surface of the copper. Examined after three days the copper remained perfectly clean, whilst the tin was rapidly corroded: no blueness appeared in this liquor; though, in a comparative experiment, when *copper alone* and the same fluid mixture was used, there was a considerable corrosion of the copper, and a distinct blue tint in the liquid.

If one-twentieth part of the surface of tin prevented the action of sea-water rendered slightly acidulous by sulphuric acid, I had no doubt that a much smaller quantity would render the action of sea-water, which depended only upon the loosely attached oxygen of common air, perfectly null; and on trying $\frac{1}{200}$ part of tin, I found *the effect* of its preventing the corrosion of the copper perfectly decisive.

5. This general result being obtained, I immediately instituted a number of experiments, in most of which I was assisted by Mr. Faraday, to ascertain all the circumstances connected with the preservation of copper by a more oxidable metal. I found, that whether the tin was placed either in the middle, or at the top, or at the bottom of the sheet of copper, its effects were the same; but, after a week or ten days, it was found that the defensive action of the tin was injured, a coating of sub-muriate having formed, which preserved the tin from the action of the liquid.

With

With zinc or iron, whether malleable or cast, no such diminution of effect was produced. The zinc occasioned only a white cloud in the sea-water, which speedily sunk to the bottom of the vessel in which the experiment was made. The iron occasioned a deep orange precipitate: but after many weeks, not the smallest portion of copper was found in the water; and so far from its surface being corroded, in many parts there was a regeneration of zinc or of iron found upon it.

6. In pursuing these researches, and applying them to every possible form and connection of sheet copper, the results were of the most satisfactory kind. A piece of zinc as large as a pea, or the point of a small iron nail, were found fully adequate to preserve forty or fifty square inches of copper; and this, wherever it was placed, whether at the top, bottom, or in the middle of the sheet of copper, and whether the copper was straight or bent, or made into coils. And where the connection between different pieces of copper was completed by wires, or thin filaments of the fortieth or fiftieth of an inch in diameter, the effect was the same; every side, every surface, every particle of the copper remained bright, whilst the iron or the zinc was slowly corroded.

A piece of thick sheet copper, containing on both sides about sixty square inches, was cut in such a manner as to form seven divisions, connected only by the smallest filaments that could be left, and a mass of zinc, of the fifth of an inch in diameter, was soldered to the upper division. The whole was plunged under sea-water; the copper remained perfectly polished. The same experiment was made with iron: and now, after a lapse of a month, in both instances, the copper is as bright as when it was first introduced, whilst similar pieces of copper, undefended, in the same sea-water, have undergone considerable corrosion, and produced a large quantity of green deposit in the bottom of the vessel.

A piece of iron nail about an inch long was fastened by a piece of copper wire, nearly a foot long, to a mass of sheet copper, containing about forty square inches, and the whole plunged below the surface of sea-water; it was found, after a week, that the copper was defended by the iron in the same manner as if it had been in immediate contact.

A piece of copper and a piece of zinc soldered together at one of their extremities, were made to form an arc in two different vessels of sea-water; and the two portions of water were connected together by a small mass of tow moistened in the same water: the effect of the preservation of the copper took place in the same manner as if they had been in the same vessel.

As the ocean may be considered, in its relation to the quantity of copper in a ship, as an infinitely extended conductor, I endeavoured to ascertain whether this circumstance would influence the results; by placing two very fine copper wires, one undefended, the other defended by a particle of zinc, in a very large vessel of sea-water, which water might be considered to bear the same relation to so minute a portion of metal as the sea to the metallic sheeting of a ship. The result of this experiment was the same as that of all the others; the defended copper underwent no change; the undefended tarnished, and deposited a green powder.

Small pieces of zinc were soldered to different parts of a large plate of copper, and the whole plunged in sea-water: it was found that the copper was preserved in the same manner as if a single piece had been used.

A small piece of zinc was fastened to the top of a plate of polished copper, and a piece of iron of a much larger size was soldered to the bottom, and the combination placed in sea-water. Not only was the copper preserved on both sides in the same manner as in the other experiments, but even the iron; and after a fortnight, both the polish of the copper and the iron remained unimpaired.

7. I am continuing these researches, and I shall communicate such of them as are connected with new facts, to the Royal Society.

The Lords Commissioners of the Admiralty, with their usual zeal for promoting the interests of the Navy by the application of science, have given me permission to ascertain the practical value of these results by experiments upon ships of war; and there seems every reason to expect (unless causes should interfere of which our present knowledge gives no indications) that small quantities of zinc, or, which is much cheaper, of malleable or cast iron, placed in contact with the copper sheeting of ships, which is all in electrical connection, will entirely prevent its corrosion. And as negative electricity cannot be supposed favourable to animal or vegetable life; and as it occasions the deposition of magnesia, a substance exceedingly noxious to land vegetables, upon the copper surface; and as it must assist in preserving its polish, there is considerable ground for hoping that the same application will keep the bottoms of ships clean; a circumstance of great importance both in trade and naval war.

It will be unnecessary for me to dwell upon the economical results of this discovery, should it be successful in actual practice, or to point out its uses in this great maritime and commercial country.

I might

I might describe other applications of the principle to the preservation of iron, steel, tin, brass, and various useful metals; but I shall reserve this part of the subject for another communication to the Royal Society.

V. Solution of a Geodetical Problem. By J. IVORY, Esq.
M.A. F.R.S.

IT is proposed to solve the following problem:

The length of a geodetical line on the earth's surface, together with the latitude, the longitude, and the azimuth, of one of its extremities, being given; it is required to determine the latitude, the longitude, and the azimuth of the other extremity.

The earth, being supposed an oblate spheroid of revolution, we may put unit for the polar semi-axis, and represent the equatorial semi-diameter by $\sqrt{1+e^2}$: then, if x, y, z be three rectangular co-ordinates of a point in the surface, x and y being parallel, and z perpendicular, to the equator; we shall have

$$\frac{x^2+y^2}{1+e^2} + z^2 = 1.$$

And if ds represent the element of a line traced in any manner upon the surface, we shall further have

$$ds = \sqrt{dx^2 + dy^2 + dz^2}.$$

Again, if we assume,

$$x = \sqrt{1+e^2} \cos \phi \cos \psi,$$

$$y = \sqrt{1+e^2} \sin \phi \cos \psi,$$

$$z = \sin \psi,$$

these values will satisfy the equation of the surface, without supposing any relation between the angles ϕ and ψ . Differentiate these values, and substitute the differentials in the expression of ds ; and, for the sake of brevity, put

$$V = \sqrt{1+e^2 \sin^2 \psi + (1+e^2) \cos^2 \psi} \frac{d\phi^2}{d\psi^2},$$

then,

$$ds = d\psi V.$$

It is easy to discover that ψ is the true latitude; that is, it is the complement of the angle which the perpendicular to the surface of the spheroid makes with the polar axis. If λ denote the given latitude of the beginning of the geodetical line, and $\delta\lambda$ the difference of latitude at any other point, then $\psi = \lambda + \delta\lambda$. The arc ϕ measures the angle between two meridians: it is therefore the difference of longitude reckoning

from the meridian that passes through the beginning of the geodetical line. The azimuths at the extremities of the intercepted part of the line will be denoted by μ and μ' , of which the first is supposed to be known.

The foregoing expression of ds is general, and will apply to any line that can be traced on the surface of the spheroid. But a geodetical line is the shortest that can be drawn between any two of its points; and we may employ this property to investigate its equation. Now, by making s and ϕ vary, we get

$$d\delta s = \frac{(1+e^2) \cos^2 \psi \cdot \frac{d\phi}{d\psi} d\delta\phi}{V};$$

and, by integrating,

$$\delta s = \delta\phi \times \frac{(1+e^2) \cos^2 \psi \cdot \frac{d\phi}{d\psi}}{V} - \int \delta\phi \times d. \frac{(1+e^2) \cos^2 \psi \cdot \frac{d\phi}{d\psi}}{V}.$$

Hence the condition of a minimum length between two fixed points, is expressed by this equation, viz.

$$d. \frac{(1+e^2) \cos^2 \psi \cdot \frac{d\phi}{d\psi}}{V} = 0;$$

and, consequently,

$$\frac{(1+e^2) \cos^2 \psi \cdot \frac{d\phi}{d\psi}}{V} = a,$$

a being a quantity which is constant in the whole length of the geodetical line.

Let ds' be what ds becomes when x and y only vary, and z remains constant; then,

$$ds' = \sqrt{1+e^2} \cdot \cos \psi \cdot d\phi;$$

and, because $ds = Vd\psi$, we get, by substitution,

$$\frac{\sqrt{1+e^2} \cdot \cos \psi \cdot ds'}{ds} = a.$$

But ds' is perpendicular to the meridian on the surface of the spheroid, and ds cuts the same meridian in the azimuth angle μ' ; wherefore $ds' = ds \sin \mu'$. Consequently,

$$\cos \psi \sin \mu' = \frac{a}{\sqrt{1+e^2}}.$$

This equation expresses a distinguishing property of the lines of shortest distance upon the surface of a spheroid. The product of the cosine of the latitude and the sine of the azimuth remains constantly the same through the whole length of every such line. In the sphere, which is the extreme case when

when e is evanescent, the criterion belongs to the great circles, which are therefore the lines of shortest distance. In the other extreme case, when the spheroid flattens into a plane, the cosine of the latitude is the rectilinear distance from the pole, and the criterion belongs to any straight line drawn in the plane.

As the last equation is general for all points of the geodetical line, it will be true when applied to the initial point of the measurement; and thus we get

$$\text{Cos } \lambda \sin \mu = \frac{a}{\sqrt{1+e^2}}.$$

Consequently,

$$\text{Cos } \lambda \sin \mu = \frac{\sqrt{1+e^2} \cdot \cos \psi \frac{d\phi}{d\psi}}{V}.$$

From this equation we obtain

$$d\phi = \frac{\sqrt{1+e^2} \sin^2 \psi}{\sqrt{1+e^2}} \times \frac{\cos \lambda \sin \mu d\psi}{\cos \psi \sqrt{\cos^2 \psi - \cos^2 \lambda \sin^2 \mu}};$$

and again, by substituting this value, we get

$$ds = \frac{d\psi \cos \psi \sqrt{1+e^2} \sin^2 \psi}{\sqrt{\cos^2 \psi - \cos^2 \lambda \sin^2 \mu}}.$$

It will now be proper to introduce two new quantities, ϕ' and s' , connected with ϕ and s by these equations, viz.

$$\begin{aligned} d\phi' &= d\phi \times \frac{\sqrt{1+e^2}}{\sqrt{1+e^2} \sin^2 \psi}, \\ ds' &= \frac{ds}{\sqrt{1+e^2} \sin^2 \psi}. \end{aligned} \quad (\text{A})$$

And when these new quantities are substituted, the foregoing equations will become

$$\begin{aligned} d\phi' &= \frac{\cos \lambda \cos \mu d\psi}{\cos \psi \sqrt{\cos^2 \psi - \cos^2 \lambda \sin^2 \mu}}, \\ ds' &= \frac{d\psi \cos \psi}{\sqrt{\cos^2 \psi - \cos^2 \lambda \sin^2 \mu}}. \end{aligned} \quad (\text{B})$$

In these last equations there are now no traces of the spheroid. They express the relations of the parts of a spherical triangle; the sides being s' , $90^\circ - \lambda$, $90^\circ - \psi$; and ϕ' , μ' , are the angles opposite to s' and $90^\circ - \psi$. The third angle of the triangle is μ' , or the azimuth at the end of the geodetical line; and it is determined by the equation

$$\text{Cos } \psi \sin \mu' = \cos \lambda \sin \mu.$$

The equations (A) show in what manner the quantities ϕ and s , which belong to the spheroid, depend upon the like quantities ϕ' and s' on the surface of the sphere.

In

In the spherical triangle two parts only are known, namely, the side $90^\circ - \lambda$, and the angle μ : but it is easy to find the side s' from the length of s , which is known by actual measurement. Since e^2 is a very small fraction, we may, in the formula

$$ds' = \frac{ds}{\sqrt{1+e^2 \sin^2 \psi}},$$

neglect the variation of the latitude, and suppose $\psi = \lambda$; then

$$s' = \frac{s}{\sqrt{1+s^2 \sin^2 \lambda}},$$

which is an approximation sufficiently near. To obtain another approximation, put $\cos \psi = \cos \lambda$ in the equations (B), then

$$ds' = \frac{d\psi}{\cos \mu};$$

$$\psi = \lambda + \cos \mu \times s' = \lambda + \cos \mu \times s.$$

Wherefore, at the middle point of the geodetical line, we have

$$\psi = \lambda + \frac{\cos \mu}{2} s;$$

and if we suppose that, in the foregoing formula, ψ does not vary from the mean value, we shall get

$$s' = \frac{s}{\sqrt{1+e^2 \sin^2 \left(\lambda + \frac{\cos \mu}{2} s \right)}}.$$

This last value is now more than sufficient for any practical purpose.

Having found s' , the other parts of the spherical triangle that remain unknown, are to be computed by the rules of spherical trigonometry. By this means we obtain,

$$\sin \psi = \sin (\lambda + \delta \lambda) = \sin \lambda \cos s' + \cos \lambda \cos \mu \sin s';$$

$$\sin \mu' = \frac{\cos \lambda \sin \mu}{\cos (\lambda + \delta \lambda)};$$

by which formulæ, the difference of latitude $\delta \lambda$, and the azimuth μ' , will be found.

And, again, we have further,

$$\sin \phi' = \frac{\sin \mu \sin s'}{\cos (\lambda + \delta \lambda)};$$

and, ϕ' being found, it is manifest from what has already been said that we shall obtain ϕ , or the true difference of longitude in the spheroid; by the formula

$$\phi = \phi' \times \sqrt{\frac{1+e^2 \sin^2 \left(\lambda + \frac{\cos \mu}{2} s \right)}{1+e^2}}.$$

In practice it will be most convenient to reduce the expressions

sions of $\delta\lambda$, $\mu - \mu'$, and ϕ' , into series containing the powers of s' .

In two particular cases the general formulæ become more simple.

First, when the geodetical line is perpendicular to the meridian, the spherical triangle becomes right-angled, which renders the computation less complicated.

Secondly, when the geodetical line is upon the meridian, the angles of azimuth and the difference of longitude are evanescent; the difference of latitude is equal to s' ; and the problem is reduced to find s' for a given value of s , from this equation, viz.

$$ds = ds' \sqrt{1 + e^2 \sin^2(\lambda + s')};$$

which, in almost every case, is sufficiently solved by the formula,

$$s' = \frac{s}{\sqrt{1 + e^2 \sin^2(\lambda + \frac{1}{2}s)}}.$$

July 10, 1824.

JAMES IVORY.

POSTSCRIPT.—In the First Part of the Philosophical Transactions for 1824, just published, there is a short paper by Dr. Young, containing a rule for the astronomical refraction. It is no more than a particular case of my general formula. If we write y for $\frac{r}{r'}$, and z for $\frac{e}{e'}$, in the expressions at p. 422 of the last Number of this Journal, we shall obtain

$$y = (1 - f) z^{\frac{m+1}{m}} + fz^2,$$

$$f = \frac{1}{4} \cdot \frac{m-4}{m-1}.$$

With respect to these equations, it may be added, as already remarked at p. 450 Phil. Trans. for 1823, that when m is less than 4, f is negative; the total height of the atmosphere is less than 25 miles; and the rate of the gradation of heat, although it agrees with nature at the earth's surface, increases in ascending. For these reasons I have excluded all these cases in seeking the value of the exponent m , that will best represent the real atmosphere of the earth; or, as Dr. Young terms it, I have rejected them as inadmissible.

Now put $m = 2$; then

$$f = -\frac{1}{2},$$

$$y = \frac{3}{2} z^{\frac{3}{2}} - \frac{1}{2} z^2,$$

which is Dr. Young's assumption.

In

In Dr. Young's paper, no reason is given why the refractions should be more exact when they are computed by the assumption adopted than by any other. We may observe here, by the by, that this mode of proceeding is at present not uncommon in physical inquiries where the mathematics are concerned; the real difficulties being often got rid of, by a phrase, or by some analogy, or by sliding in a formula to serve as the basis of a calculation. In the present instance we are referred to something that is said to be demonstrated in the *Journal of the Royal Institution*. This probably alludes to the passage at p. 148 of No. 31, to which I have already adverted in this *Journal* for April last. The reader will find that nothing is proved; and that the whole amounts to the applying of the same assumption, viz. $m=2$, to another of my general formulæ, as indeed is very plainly implied in the words of the passage.

Dr. Young concludes his paper with giving a finite formula of four terms, similar to that in the *Nautical Almanac*, by which, he says, my table may be computed with great accuracy. Now this very fairly concedes every thing I have at any time said of the formula, and the method for the refractions in the *Nautical Almanac*. I have said that the method does not emanate from any exact theory; that the formula is empirical, and of no use till a table be produced, by means of which the proper values are to be assigned to the indeterminate coefficients. The formula will thus represent, to a certain degree of exactness, the French table, or that of M. Bessel, or that of Dr. Bradley, or mine. But as it will represent any table whatever, good or bad, it can be an authority for none. The real foundation of the table in N. A. is the manner in which the coefficients of the formula have been obtained; and not a word has escaped that can throw light upon this point in all the discussions that have been sent forth to the public quarterly in the *Journal of the Royal Institution*. It appears that the table has been so constructed as to agree, partly with M. Bessel's table, partly with that of the French astronomers, and partly to fall between the two. In this manner we can exactly appreciate the table; whereas it is enveloped in mystery and obscurity when we regard it as a creation of the formula.

July 10, 1824.

J. I.

VI. *Analyses of a Series of Papers on the Structure, Distribution, and Functions of the Nerves; by CHARLES BELL, Esq.; which have appeared in some late Volumes of the Philosophical Transactions.*

WE propose, in the present article and continuations of it, to present our readers with analyses of a valuable series of papers on the nerves, by Mr. C. Bell, which have appeared in the Philosophical Transactions from 1821 to 1823; and shall probably conclude them with some remarks on certain parts of his system.

I. *On the Nerves; giving an Account of some Experiments on their Structure and Functions, which lead to a new Arrangement of the System.*—Phil. Trans. 1821, p. 398–422.

The author's inquiry in the present paper is limited to the nerves of respiration, and in his conception of this matter they form a system of great extent, since they comprehend all the nerves which serve to combine the muscles employed in the act of breathing and speaking.

Now the number of muscles concerned in respiration is unquestionably great; as all those which are in any way connected with or employed in the act of breathing, or in the common actions of coughing, sneezing, speaking and singing, are regarded by the author as muscles of respiration. The association of these muscles is effected by certain nervous chords which combine them in the performance of the above-named actions, and which he calls respiratory nerves. To illustrate the sense in which this latter term is intended to be employed, the following case serves extremely well: "When a post-horse has run its stage, and the circulation is hurried and the respiration excited, what is his condition? Does he breathe with his ribs only; with the muscles which raise and depress the chest? No. The flanks are in violent action; the neck as well as the chest is in powerful excitement; the nostrils as well as the throat keep time with the motion of the chest. So if a man be excited by exercise or passion, or by whatever accelerates the pulse, the respiratory action is extended and increased, and, instead of the gentle and scarcely perceptible motion of the chest, as in common breathing, the shoulders are raised at each inspiration, the muscles of the throat and neck are violently drawn, and the lips and nostrils move in time with the general action; and if he does not breathe through the mouth, the nostrils expand, and fall in time with the rising and falling of the chest; and that apparatus of cartilages and muscles of the nose (which are as curious as the mechanism of the chest, and which are for ex-

panding these air-tubes) are as regularly in action as the levator and depressor muscles of the ribs." It is very evident that, when an animal is in such a state, many muscles are combined in the act of respiration, which are seated apart from each other, and are otherwise capable of performing distinct offices: it is therefore the object of this paper to show what nerves they are which effect this combination, and are consequently to be known as respiratory nerves; but before these can allow of being enumerated, it is necessary to observe,

1st, *That the nerves of the animal frame are complex, in proportion to the variety of functions which the parts have to maintain.*

For, on minutely and carefully examining the nerves of the human body and comparing them with those of other animals, a very singular coincidence is observed between the number of organs, the compound nature of their functions, and the number of nerves which are transmitted to them. No organ which possesses only one property or endowment, has more than one nerve, however exquisite the sense or action may be; but if two nerves, coming from different sources, are directed to one part, this is the sign of a double function performed by it. If a part, or organ, have many distinct nerves, we may be certain that, instead of having a mere accumulation of nervous power, it possesses distinct powers, or enters into different combinations, in proportion to the number of its nerves. The knowledge of this circumstance gives new interest to the investigation of this part of anatomy.

Thus, in reviewing the comparative anatomy of the nerves of the mouth, we find that in the creatures which do not breathe, the mouth having one function only to perform, one nerve is sufficient. It is the same with the face, the nostrils, and the throat, of those animals where no complexity of relations or of organization exists, there being no variety of nerves in such a case. But in dissecting the parts composing the tongue, throat, and palate, of the human subject, five different trunks of nerves may be found corresponding with the multiplied offices of the mouth in man, such as respiration, manducation, speech, taste and feeling. Surely the same nerve cannot serve for the action of gnawing and feeding in the lower animals of simple structure, and also for the governance of those complicated operations which interpret wants and sentiments in man.

2dly, *That the nerves of all creatures may be divided into two parts or systems; the one simple and uniform, the other complex and irregular in proportion to the complexity of organization.*

The principle which is to guide us towards a knowledge of these

these two distinct classes is obtained, in spite of the difficulties which present themselves on minutely displaying the nerves of the face, mouth, throat, and other parts of the human subject, by ascertaining what parts of the organization of an animal are necessary to life and motion; and what organs are superadded as the animal advances in the scale of existence, as necessary to higher and more complex enjoyments and actions. Where an animal is endowed with mere sensation and locomotion, without a central organ of circulation, and with no organ of respiration but what is generally diffused over the whole frame, the nerves are extremely simple, consisting only of two chords running in the length of the body, with branches going off laterally to the several divisions of the frame. There is no intricacy to be seen, nor can a double supply of nerves be observed; but each portion of the frame has an equal supply: and the central line of connexion is sufficient to combine the actions of the muscles, and to give them the concatenation necessary to locomotion. This system is designated by Mr. Bell, the original and symmetrical system, which, he says, exists as well in the human body as in the leech or worm, but is observed by those additional or superadded nerves which belong to those organs which, tracing the orders of animals upwards, are observed gradually to accumulate until we arrive at the complication of the human frame. These additional or superadded nerves, however, do not destroy the original system; for when we separate certain nerves, it is presented even in the human body.

This original and symmetrical system is constituted of the nerves of the spine, the tenth or sub-occipital nerve, and the fifth pair of the head or trigeminus of Willis: all which present a striking agreement with each other with respect to origin, modes of distribution, and function; in that they all have double origins, and ganglia on one of their roots; they go out laterally to certain divisions of the body; they do not interfere to unite the divisions of the frame; they are all muscular nerves ordering the voluntary motions of the frame; they are all exquisitely sensible, and the source of the common sensibility of the surfaces of the body; they pervade every part, and yet are symmetrical and simple as the nerves of the lower animals.

Exposing the nerves of this class in a living animal, they exhibit the highest degree of sensibility, and allow of being distinguished from the nerves of the other class, by the comparative want of sensibility of the latter. The division of a nerve of this original class is followed by a loss of sensibility to the skin and common substance; whereas these parts are

in no measure deprived of it when a nerve not of this class is divided.

The nerves of the irregular and complex system, in contradistinction to those of the original and symmetrical one, do not arise by double roots, nor have they any ganglia on their origins; they come off from the *medulla oblongata* and the upper part of the spinal marrow; and from this origin they diverge to those several remote parts of the frame which are combined in the motion of respiration. These are the nerves which give the appearance of confusion to the dissection, because they cross the others, and go to parts already plentifully supplied from the other system.

The author enumerates the following as respiratory nerves, according to their functions :

1. The *par vagum*, or the eighth pair of Willis, takes its course to the larynx, lungs, heart, and stomach, and associates them together; they being at the same time supplied with nerves from other sources.

2. The *portio dura* of the seventh or *respiratory nerve* of the face. By the division of this nerve the face is deprived of its consent with the lungs, and of all expression of emotion.

3. The *spinal accessory*, or *superior respiratory nerve of the trunk*. In its course it supplies the muscles of the neck and shoulder, which are already profusely supplied by the regular system of nerves. When it is divided, those muscles which were in action as respiratory muscles cease their co-operation, but remain capable of voluntary actions.

4. The *phrenic*, or *diaphragmatic*, or *great internal respiratory nerve*. This is the only one of the system which has been known as a respiratory nerve.

5. The *external respiratory nerve*, connected with and resembling the former as to origin; it passes through the axilla and goes to the muscles on the outside of the ribs, which are supplied with nerves from the other system coming out betwixt the ribs as well. This nerve has been entirely overlooked.

These four last-mentioned nerves govern the muscles of the face, neck, shoulders, and chest, in the actions of excited respiration, and are absolutely necessary to speech and expression. Under the same class, moreover, must be ranked the nerves which go to the tongue, throat, and windpipe, these being no less essential to complete the act of respiration; as the glosso-pharyngeal, the lingual, or ninth of Willis, and the branches of the *par vagum* to the superior and inferior larynx.

With the view to give a more detailed illustration of the nerves being divisible or distinguishable into two distinct classes,

Mr.

Mr. Bell confines himself more immediately to the nerves of the face; for the human countenance performs many functions, and in it are combined the organs of mastication, of breathing, of natural voice and speech, and of expression. The nerves upon which these functions are dependent are here distinct, and run apart from each other, until they meet at their extremities: they moreover take different courses through the bones of the head, and therefore render the results of any experiments which may be made upon them more certain and determinate.

The nerves of the face are the *trigeminus* or *the fifth of Willis*, and the *portio dura* of the seventh, which in this paper is called *the respiratory nerve of the face*.

The existence of the former is constant in all animals which have a stomach with palpi or tentacula to embrace their food. If a feeler of any kind, having no connexion with respiration, projects from the head of an animal, as in the instance of the antenna of the lobster, it possesses sensibility by being supplied with a branch from this nerve: whereas, should it be connected with respiration at the same time, as is the case with the hollow trunk of the elephant, two nerves are readily found, both of great size; the one a continuation of the superior maxillary branch of the fifth; the other derived from the respiratory or seventh. This nerve is subservient to the same functions in the highest or most complex animals as in the lowest or most simple; being the nerve of taste, of the muscles of the face and jaws, and of common sensibility; its branches being distributed minutely to these organs and profusely to the muscles which move the lips on the teeth.

The *portio dura* only exists where there is some consent established between the face and the respiratory organs. In fishes there is, strictly speaking, no *portio dura* of the seventh, the nerve resembling it being a branch of the *par vagum*, which, instead of being distributed forward to the face, passes backwards to the muscles of the gills. In the human subject this nerve has a very extensive distribution, penetrating to all the muscles of the face, which are also supplied with the branches of the fifth pair, and to the skin in company with the minute vessels of the cheek; besides sending numerous branches to the superficial muscles of the throat and neck, which are connected with branches of the spinal and respiratory nerves. These two sets of nerves, moreover, of the face, differ from each other as to texture; the respiratory being found to correspond with the structure of the *par vagum*, the filaments of which are close, and like a minute plexus; whereas those of the fifth are large and round, and with less intricacy in their texture.

texture. And it is worthy of consideration, that every one of its branches is joined by divisions of the fifth, as if it was not alone sufficient to supply any individual part with nervous power.

A question therefore very naturally arises, Whether these nerves do not perform different offices? and, from the assistance afforded by the knowledge of the human structure and of comparative anatomy, the author is prepared to decide the matter by experiment. The ass and the dog were the two animals chiefly selected for this purpose. The division of the portio dura of one side during excited or extraordinary respiration, is instantly followed by a loss of motion of the nostril of the same side, whilst that of the other continues synchronous, or in unison, with the risings and fallings of the chest. The animal gives no sign of pain, nor struggles when this nerve is cut across. The power of manducation continues without the slightest impediment. The side of the face in which the division has been made, remains at rest and placid during the highest excitement of the other parts of the respiratory organs. Even in the last dying efforts of the respiratory muscles for the drawing in of breath, when the muscles of the mouth, nostrils, and eye-lids, are in a violent state of spasm, this remains unmoved. A man had the trunk of the respiratory nerve of the face injured by a suppuration, which took place anterior to the ear, and through which it passed in its course to the face. It was observed, that in smiling and laughing, his mouth was drawn in a remarkable manner to the opposite side. The attempt to whistle was attended with a ludicrous distortion of the lips; when he took snuff and sneezed, the side where the suppuration had affected the nerve remained placid, while the opposite side exhibited the usual distortion. On cutting the respiratory nerve on one side of the face of a monkey, the very peculiar activity of his features on that side ceased altogether. The timid motions of his eye-lids and eye-brows were lost, and he could not wink on that side; and his lips were drawn to the other side, like a paralytic drunkard, whenever he showed his teeth in rage.

Mr. Bell cut a tumour from before the ear of a coachman; a branch of the nerve which goes to the angle of the mouth was divided. Some time after he returned to thank Mr. B. for ridding him of a formidable disease, but complained that he could not whistle to his horses.

It would appear from hence, that the association of the muscles of the face with the act of breathing is effected through the operation of this nerve.

Exposing and touching the superior maxillary branch of the
the

the fifth nerve gives acute pain; but its division causes no change in the motion of the nostril, the cartilages continuing to expand regularly in the act of respiration; but the side of the lip may be observed to hang low and to be dragged to the other side; and if the nerve of the opposite side be divided also, the loss of motion of the lips in eating is very obvious. The division of a branch of the fifth which goes to the forehead in a man, did not cause paralysis of the superciliary muscles; but an abscess and ulcer seated anterior to the ear of another individual, affected the superior branch of the respiratory nerve; the eye-brow fell low, and did not follow the other when the features were animated by discourse or emotion. The infra-orbital branch of the fifth, on the left side, was cut across, and the portio dura or respiratory nerve on the right side of the same animal also; sensibility to pain remained on this side, while that of the left was completely destroyed. The difference of suffering moreover was most marked at the time of their being divided; the division of the fifth was accompanied with signs of acute pain, that of the seventh or respiratory with none at all. When carbonate of ammonia was applied to the nostrils of the ass whose respiratory nerve had been cut, the opposite side of the nose and face was curled up with the peculiar expression of sneezing, whilst the side on which the nerve was divided remained quite relaxed, although the branches of the fifth pair and the sympathetic were entire. The same experiment on a dog under similar circumstances caused the action of sneezing on the sound side only.

From these facts and experiments it may be concluded, that the nerves of the face are divisible, as to their functions, into two distinct sets or classes; and that it is the office of the portio dura or respiratory class, to associate the actions of the muscles of the face with those of the other organs of respiration; seeing that these muscles serve to actuate and expand the passages to the lungs, and to controul the motions of the lips, the nostrils, and velum palati, simultaneously with the respiration of the lungs. It can also be proved that the throat, neck, shoulders, and chest, have nerves similar to the portio dura both in structure and in function, which serve to unite all the extended apparatus of breathing and speaking. The action of smiling seems also to be owing to the influence of this nerve; for although it has been presumed that this act is peculiar to the human countenance, yet there is a great similarity, if not identity of expression presented sometimes in the face of the dog when he turns out the edge of his lips, leaps, and twists his body and wags his tail as he is fawning on his master;

master; but dividing the respiratory nerve of one side, the expression, which consisted in that peculiar turn of the lip, could only be observed on the other. Another conclusion to be drawn from the experiments above detailed, is that the *portio dura*, besides being a nerve of respiration, is also a grand nerve of expression, not only in man, but in brutes also; which is confirmed by the circumstance of the disappearance of that excitement seen in a dog's head, his eyes, and ears, when fighting, on the division of this nerve.

There is moreover a peculiar distinction observable between these two sets of nerves of the face in regard to their origins; the fifth pair receiving roots, &c. from the medullary process of the cerebrum and of the cerebellum. A ganglion is formed upon it near its origin, though some of its filaments pass on without entering into the ganglion. The respiratory nerve, on the other hand, arises from the superior and lateral part of the *medulla oblongata*, close to the *nodus cerebri*, and exactly where the *crus cerebelli* joins the *medulla oblongata*; and, what is worthy of notice, the other respiratory nerves, which form so distinguished a part of the nervous system, arise in a line with the roots of this.

The striking difference presented by these two sets of nerves in regard to sensibility would imply the necessity of ranking them under two distinct heads, if not the idea of their performing dissimilar functions; for the cutting of the fifth nerve gave pain in a degree corresponding with our notions of the sensibility of nerves; but in cutting the *portio dura*, it was not evident that the animal suffered pain at all.

“ Having brought this investigation to a conclusion, some perhaps, fatigued by its details, may ask to what does this discussion lead?

“ Were we to inquire no further, and to rest content with the inference, that the two sets of nerves distributed to the face have distinct functions; even this must prove useful both to the surgeon and physician. To the surgeon it must be useful in performing operations on the face, as well as in observing the symptoms of disease: but especially to the physician must these facts be important; he will be better able to distinguish between that paralysis which proceeds from the brain, and that partial affection of the muscles of the face, when, from a less alarming cause, they have lost the controuling influence of the respiratory nerve.

“ Cases of this partial paralysis must be familiar to every medical observer. It is very frequent for young people to have what is vulgarly called a blight; by which is meant, a slight

slight palsy of the muscles on one side of the face, and which the physician knows is not formidable. Inflammations of glands seated behind the angle of the jaw will sometimes produce this. All such affections of the respiratory nerve will now be more easily detected; the patient has a command over the muscles of the face, he can close the lips, and the features are duly balanced; but the slightest smile is immediately attended with distortion, and in laughing and crying the paralysis becomes quite distinct.

“The knowledge of the sources of expression teaches us to be more minute observers. The author had lately to watch the breathing of an infant which had been several times restored from a state of insensibility. At length the general powers fell low without any returning fit; insensibility and loss of motion stole over the frame; all but the actions excited by the respiratory nerves ceased; then each act of respiration was attended with a twitching of the muscles of the *ala nasi*, and of that muscle of the cheek which makes the dimple in smiling. It was then evident that the child could not recover; that all but the system of respiratory nerves had lost their powers; that the features, as far as they were subject to the influence of the other nerves, had fallen.

“There are conditions of the lungs, when the patient is in great danger, and yet the inflammation is not marked by the usual signs of pain and difficult motions of the chest. We shall see nothing but the twitching of those muscles of the face, which are animated by the respiratory nerve. We see a certain unusual dilatation of the nostrils, and a constrained motion of the lips, which with the change of voice is just sufficient to give alarm, and indicate the patient's condition. This is a state of the lungs very often produced after severe accidents, as gun-shot wounds, and after great surgical operations.

“These circumstances are stated to prove that the subject of expression is not foreign to medical studies; and certainly, by attention to the action of the muscles of the face, we shall find the views drawn here from the anatomy, further countenanced. We learn that smiling is an affection of the nerve of respiration on the muscles of the face, and that when laughter shakes the sides, it is only an extended and more convulsive action of the muscles produced by the same class of nerves. When to the paleness and coldness and inanimation of grief, there is added the convulsive sob and the catching of the throat, and the twitching of the lips and nostrils, we discover the same class of nerves to be affected, which, in crying, are only more obviously in operation, producing more violent contractions.

“ In all the intermediate emotions between these extremes, the varieties of expression in the face are produced by the opposition of the two powers affecting the same muscles; the one is a voluntary power, by which we restrain the features and conceal emotion; the other is an involuntary power, which cannot be always controuled, but which will sometimes have sway and mingle its influence.”

[To be continued.]

VII. *Some Observations on the Migration of Birds. By the late EDWARD JENNER, M.D. F.R.S.; with an Introductory Letter to Sir HUMPHRY DAVY, Bart. Pres. R.S., by the Rev. G. C. JENNER.**

SIR,

IT had long been the intention of my late revered uncle, Dr. Jenner, to lay the accompanying Observations on the Migration of Birds before the Royal Society, as well from inclination, as to redeem a pledge he had given some years ago to that learned body; but which he was unable to accomplish, in consequence of his extensive correspondence with almost every part of the globe on the interesting subject of Vaccination, which occupied nearly the whole of the time his more immediate professional avocations would allow him to bestow on other objects.

It was my peculiar happiness to accompany Dr. Jenner in most of his investigations of the phænomena of migration; and the paper I have now the honour of presenting, was left in my hands at the time of his decease.

Had it pleased Providence to have spared him a little longer, he might probably have corrected some inaccuracies in the style and order of his paper, that may now perhaps appear conspicuous to the reader, but which I did not conceive myself justified in attempting.

I have the honour to be, Sir,

Your most obedient humble servant,

Stone, near Berkeley, May 29, 1823.

G. C. JENNER.

*To Sir Humphry Davy, Bart.
President of the Royal Society.*

I.

It is not my intention, in the following pages, to give a general history of the migration of birds. The order in which

* From the Philosophical Transactions for 1824, Part I.

they

they appear and disappear, their respective habits, and many other observations, have been given with considerable accuracy by several naturalists who have paid attention to this very curious subject. It is with a view of representing some facts, hitherto unnoticed, chiefly with respect to the *cause*, which excites the bird, at certain seasons of the year, to quit one country for another, that I communicate the following pages to this learned body.

But before I proceed to state my observations on this head, it may be necessary to adduce some arguments first, in support of the reality of migration, the fact itself not being generally admitted; and secondly, against the hypothesis of a state of torpor, or what has been called the hibernating system.

In the first place, the ability of birds to take immensely long flights is proved by the observations of almost every person conversant with the seas. To the many instances already recorded, I shall add the following:

My late nephew, Lieutenant Jenner, on his passage to Newfoundland, saw on the 20th of May the hobby hawk. It came on board, and was secured. The day following a swallow came on board. At this time the ship was steering a course direct for that island, and was not within the distance of an hundred leagues of any land. His brother, the Reverend G. C. Jenner, in crossing the Atlantic, observed an owl (of what species he could not precisely ascertain, but he believes it to be the common brown owl) gliding over the ocean with as much apparent ease as if it had been seeking for a mouse among its native fields*. Wild geese have frequently been shot in Newfoundland, whose crops were plentifully stored with maize or Indian corn; consequently, these birds must have taken a pretty bold flight in a short space of time, as no corn of this kind is cultivated within a vast distance of that island. These however I do not consider as migrations of any further consequence, than just to show the powers of the wing.

My ingenious friend and neighbour, the late Reverend Nathaniel Thornbury, who had occasionally visited Holland, informed me that the pigeons about the Hague make a daily marauding excursion, at certain seasons, to the opposite shore of Norfolk, to feed on vetches, a distance of forty leagues.

* Mr. Jenner informs me, that in subsequent voyages he has taken, in the Atlantic, several hundred miles from land, the nuthatch, hoopoe, and snipe; and has often seen small birds of the linnet kind. Of the latter, a large flock came on board, perched on the rigging, appeared very lively, and after adjusting their plumage, and chirping in concert for a few minutes, took their flight in a direction for the Azores.

Now, may not this be almost considered as daring a flight as that of the bird which crosses the Atlantic? For it is not at all probable that the shores of this country can be visible to the flock when they set out.

Again: Is there not something as extraordinary in the pigeon, which can in a few hours find out its home, though taken away in a box and totally excluded from the light, to the distance of two hundred miles, as in that bird which quits one shore to seek another, whatever may be the extent of intervening seas? The fact seems to be, that we, the *little lords of the creation*, are too prone to measure the sentient principle in animals by the scale of our own ideas, and thus, unwillingly, allow them to possess faculties which may surpass our own, though peculiarly appropriate to their respective natures; but a little reflection must compel us to confess, that they are endowed with discriminating powers totally unknown to, and for ever unattainable by man. I have no objection to admit the possibility that birds may be overtaken by the cold of winter, and thus be thrown into the situation of other animals which remain torpid at that season; though I must own I never witnessed the fact, nor could I ever obtain evidence on the subject that was to me satisfactory: but as it has been often asserted, may I be allowed to suppose, that some deception might have been practised with the design of misleading those to whom it might seem to have appeared obvious? For far be it from me to insinuate that the subject has been wilfully misrepresented by those naturalists who have stated it as a fact. Yet how careful should we be in the investigation of all subjects in natural history which may captivate by their apparent novelty!

If birds crept into holes and crevices to hibernate, would they not, like quadrupeds, creep out again in a languid state, their fat all absorbed, and their bodies emaciated? We see this fact exemplified in the hedge-hog, one of the most remarkable of our hibernating animals, which retires to its hut at the approach of winter, with vast stores of fat placed in every situation where nature could find room for it. This fat is its only source of nutrition for the winter, which, by the time the sun rouses it to fresh life and activity, is exhausted, and the animal comes forth thin and emaciated. But the case with birds is extremely different. If, on the first day of its appearance, a martin, a swift, or a redstart be examined, it will be found as plump and fleshy as at any season during its stay; it appears also as strong on the wing, and as full of activity at that period as at any other during its abode with us.

How

How the cuckoo, that disappears at so early and so hot a season as the first week in July, can become torpid, is beyond the power of conception.

The apparent incapability of the landrail to perform the task of migration, has often been so strongly adduced as a presumptive argument in favour of the hibernating system, that those who do not admit that of migration, were it to remain unnoticed, might urge it as an objection. It must be admitted, that a superficial examination of the habits of this bird tends to favour the supposition of its incapacity for so great an exploit, as it often rises from the ground like an half-animated lump, and seems with difficulty to take a flight of a hundred yards; but let us remark its powers when seriously alarmed. Should it be forced upon the wing by any extraordinary cause, by the pursuit of a hawk, for example, the velocity of its flight, and the rapidity of its evolutions to avoid the common enemy of its race, will at once appear. This is no very rare exhibition. Necessity here, as in migration, becomes the parent of exertion, which, when thus called forth, cannot be shown in a much greater degree by any of the feathered tribe. The moor-hen (which winters with us) gives another instance of what a bird, which appears so much to want activity in its ordinary flights, is capable of performing when exertion is actually required. When pursued by a hawk, and self-preservation calls up all its powers, it may be seen to rush up into the air with amazing velocity, almost as high as the eye can reach, then darting down with an equal pace, it often, by such rapid manœuvres, escapes the destructive talons of its swift pursuer.

It is a remarkable fact that the swallow tribe, and probably many other birds which absent themselves at stated periods, should return annually to the same spot to build their nests. The swift, which for nine months has some distant region to roam in, was selected for the purpose of an experiment to ascertain this with precision. At a farm-house in this neighbourhood I procured several swifts, and by taking off two claws from the foot of twelve, I fixed upon them an indelible mark. The year following their nesting places were examined in an evening when they had retired to roost, and there I found several of the marked birds. The second and third year a similar search was made, and did not fail to produce some of those which were marked. I now ceased to make an annual search; but at the expiration of seven years, a cat was seen to bring a bird into the farmer's kitchen, and this also proved to be one of those marked for the experiment.

That the bird, when the stimulus for migration is given, with the choice before it of almost any part of Europe for its annual

annual excursion, should so uniformly not only revisit this island, but even select the same spot for its breeding place, is certainly a wonderful occurrence. But if birds were not instinctively directed to return to their old haunts, should we not find them over-crowding some situations, while others would be left desolate? And would not this be the case if the search of food was the object of their migration? However it may be admissible, in one point of view, to consider the bird in its state of migration from this country, as a nearer neighbour than at first might be conceived, if we may be allowed to consider distance, or space, in the instance before us, as governed by the power of progressive motion, of what consequence is it to the swift, which, to use the animated expression of Mr. White, "dashes through the air with the inconceivable swiftness of a meteor," whether he comes to us from some neighbouring country, or the shores of Africa? The wonder excited by the return of these birds again to their old nesting places, would at once cease, if we could believe what has been asserted by some naturalists, and gained credit with many, namely, that at the time they disappear from us, they submerge themselves in ponds and rivers, and in this situation become torpid. If this idea had not been encouraged and supported by some new hypothesis, I should hardly have thought it necessary to have taken any serious notice of it; but as the matter now stands I will just state my opinion, why I think it impossible for any birds to be disposed of in this way.

Permit me first to call to your recollection the season of the year at which many of these birds disappear. It happens when they feel no cold blast to benumb them, and when the common food with which they are supported, is distributed through the air in the greatest abundance. At such a time, what can be the inducement to them and their young ones, which have but just begun to enjoy the motion of their wings, and play among the sunbeams, to take this dreary plunge? And how is the office of respiration to be performed during the nine months watery residence? The structure of the lungs of birds differs not essentially from that of quadrupeds, and therefore all communication with the atmosphere being cut off from the first moment of submersion, the possibility of a bird living nine months, or indeed as many minutes, under water, appears to be totally irreconcilable with the nature of their structure. I have taken a swift about the 10th of August, which may be considered as the eve of its departure, and plunged it into water; but like the generality of animals which respire atmospheric air, it was dead in two minutes.

The

The late Doctor Beddoes has thrown out a supposition, that by frequent immersion in water, the association between the movements of the heart and lungs might perhaps be destroyed, and that an animal might be inured to live commodiously for any time under water. As this will probably give new vigour to the languid system of the advocates for the submersion of birds, I think it incumbent upon me to mention it.

Though we frequently see the swallow and the martin sprinkle and splash themselves as they glide over the surfaces of ponds and rivers, yet we never see them dip under for a single moment; indeed a few plunges would so moisten their wings as to prevent their flying, and we should see them occasionally in this disordered state fluttering on the shore. If they went to the sea side, and got beyond the reach of the eye to inure themselves to this element, how could they return, divested as they must be either of the means of swimming or flying? Whoever has observed the common tame duck driven to the necessity of repeatedly diving from the pursuit of a water-dog, must have noticed how exhausted it rises to the surface of the water after a short period of submersion, and how incapable it is of flying, in consequence of the soaking of its wings. The same may be said of birds more in the habit of diving, the grebes and divers. When entangled in a net they soon perish, or when they happen to dive under ice that may chance to overspread a pond; no uncommon place of resort for some of the smaller species of grebes.

I have always been much attached to that faithful animal, the Newfoundland dog, and have often procured from that country those dogs that had been much accustomed to diving, and which had been kept to the practice; yet I never observed that any of them attained by habit the power of remaining under water longer than thirty seconds, and even then, on rising to the surface, they appeared confused. Negroes and other men who have been employed in seeking among sunken rocks the hidden treasures of the deep, are said to have acquired a habit of remaining some minutes under water; but the time was probably measured by a rude guess, and not by a stop-watch.

Having thus called the attention of the Society to such statements as give support to the fact of migration, and having also endeavoured to controvert the notion of an hibernating system, I beg to draw their attention to what I conceive to be the true *cause* of migration.

At the coming on of spring we observe our more domestic birds, those that approach our houses, and are most familiar to us, assuming new habits. The voice, gesticulation, and the attachment

attachment which the male begins to show to the female, plainly indicate some new agency acting upon the constitution*. This newly excited influence, which so conspicuously alters the habits of our birds at home, is, at the same time, exerting itself abroad upon those which are destined to resort hither. *It is the preparation which nature is making for the production of an offspring by a new arrangement in the structure of the sexual organs, (viz.) the enlargement of the testes in the male, and the ovaria in the female.*

No sooner is the impulse arising from this change sufficiently felt, than the birds are directed to seek a country where they can for a while be better accommodated with succours for their infant brood, than in that from which they depart †.

It is not at the commencement of this enlargement, nor until it is considerably advanced, that the birds are prompted to migrate; and this is very wisely ordered; for were they to set off when first the testes and ovaria begin to grow tumid, they must waste much time here unnecessarily, and indeed arrive at too early a period to find a supply of food. Very little time is lost after their arrival, before they form their connubial alliances ‡. The business of nesting then begins; and as a convincing

* The rook, among many others, exhibits a familiar instance of the change of voice.

† Birds of the same species that are commonly stationary in this island throughout the year (I say commonly, for all, I believe, occasionally migrate) are migrators in other countries. The adult bird might, perhaps, find a subsistence for itself in the country it quits during the incubating season; but the nestling is probably the object nature chiefly holds in view, both with respect to food, and to the temperature of the air in which it is first to feel existence. The one may be unfit or too scanty, and the other too hot or too cold. It is wonderful to see with what peculiar care the parent birds select the food for their young until they are four or five days old. For the most part it is purely animal; but not an atom even of that is suffered to go into the nestling's stomach, that is not perfectly adapted to the tender state of its digestive powers. While the swift is feeding on small beetles that have hard crustaceous wings, and whose habitations are the air, its nestlings are fed in their early state with gnats. The sparrow, a granivorous bird, feeds its young for several days after they are hatched, with the softest insects only, now and then introducing a little coarse sand, smooth on the surface, to inure the stomach, as I suppose, to bear the same kind of substances in a more rugged state, which will shortly be required.

‡ Should a fatal accident befall either the male or female bird after this alliance is newly formed, no time is lost in unavailing sorrow, nor any great nicety shown in forming a new connexion, as the following little history will evince. A pair of magpies began to build their nest in a gentleman's garden at Burbage, in Wiltshire. Disliking their familiarity, he shot one of them from an ambush made for the purpose. The next day there were again a pair going on with the work. One of these was also shot. The loss was not long in repairing; for the day following the pair were again complete,

vincing proof that nesting is the chief cause of their errand here, this and its natural consequences occupy their attention from the time of their coming to the day of their departure. This is illustrated by the dispatch which some of them make in performing the object of their mission. The cuckoo finishes this business in a shorter space of time than any other bird; but as he deviates so widely from the common laws of the feathered society, I shall select the swift as a better example for pointing out the fact. The swift shows himself here about the beginning of May (sometimes a few stragglers appear earlier), and by the beginning of August he has completely reared his young ones, which seldom consist of more than two. At once the old birds and their family take their leave and are seen no more for that season. Now his further residence cannot be rendered unpleasant by any disagreeable change in the temperature of the air, or from a scarcity of his common food, which at this time abounds in the greatest plenty. This circumstance of the early departure of the swift, without a more apparent cause, seems to have excited much astonishment and perplexity in the mind of that attentive and ingenious naturalist, the late Mr. White of Selborne. Speaking of the swift (Letter XXI. page 184), he says, "But in nothing are swifts more singular than in their early retreat. They retire, as to the main body of them, by the tenth of August, and sometimes a few days sooner; and every straggler invariably withdraws by the twentieth, while their congeners all of them stay till the beginning of October, many of them all through that month, and some occasionally to the beginning of November. This early retreat is mysterious and wonderful, since that time is often the sweetest season of the year. But, what is more extraordinary, they begin to retire still earlier in the most southerly parts of Andalusia, where they can be no ways influenced by any defect of heat, or, as one might suppose, defect of food. Are they regulated in their motions with us by a failure of food, or by a propensity to moulting, or by a disposition to rest after so rapid a life, or by what? This is

complete, when another fell a victim to the gun. Thus the gentleman went on destroying one of them daily until he had killed seven; but all to no purpose—the remaining magpie soon found another mate. The nest was finished, and young ones were produced, which were suffered to fly. This is an extraordinary fact.—It seems to show that nature has a reserve of birds in an unconnected state, immediately ready to repair losses. Were the whole to pair at once, the circumjacent country might be insufficient to furnish food for the immense number of young ones that must burst forth at the same time.

one of those incidents in natural history that not only baffles our searches, but almost eludes our guesses!" Thus Mr. White.

Now, should the principle I have laid down be admitted, namely, that these birds come here for scarcely any other purpose than to produce an offspring, and retreat when the task is finished, how easily will all circumstances be reconciled! and how little mysterious will those things appear which naturally seemed unaccountable, not only to the amiable author from whom the foregoing passage is taken, but also to others who have written before on the same subject.

It is somewhat remarkable that so sagacious a philosopher as the illustrious and learned Ray, who so clearly saw the object of migration in fishes, should not also have been led to a sight of it in birds. After making a very just observation respecting salmons, that quit the sea and ascend up rivers with no other view than to find a place of security for their spawn in the sand, he directly says again, adverting to birds, "What moves them to shift their quarters? You will say the disagreeableness of the air to the constitution of their bodies, or want of food*."

The spring migrating birds do not arrive here at first in very large numbers. It may be observed, that in the early part of April a few swallows may be seen; soon after these a few solitary martins, and as the month advances now and then a swift. On the walls of Berkeley Castle martins build their nests in great numbers. I availed myself of their situation, and took several of them on the same night, the latter end of May. On dissection, the cause of their gradual and successive migrations appeared obvious, the testes and ovaria being in very different states of progressive forwardness. While one bird presented embryo eggs in the ovarium as large as peas, in another they were found no larger than hemp-seed. These were the extremes; for in the other birds there appeared all the intermediate stages, from the enlargement of the ovaria, sufficient to give the stimulus for migration, to the degree of forwardness just described. The same gradations in the state of the testes of the male corresponded with that of the ovaria in the females. This progressive arrival is not confined to the swallow tribe: all the birds that come early in the spring appear in the same gradual manner. I cannot help observing, that here the wise design of Providence is very conspicuous. Their appearance keeps pace with that of the in-

* Ray on the Wisdom of God in the Creation, Part I. p. 128.

sects which are to afford them food. If the numbers which flock in upon us in May, were to arrive in April, when only part of them appear, all must be insufficiently supplied, and many of course perish from a want of the needful succours; but by the middle of May, myriads of insects have produced eggs, and great numbers have either brought forth or matured their progeny; and it may be remarked there is still a greater increase of insect food by the time the young birds begin to require it. Swallows, on their first coming, feed principally upon gnats. These insects are called forth from their wintry retreats when the air is but moderately heated, 48 degrees of Fahrenheit's thermometer being sufficient to put them on the wing. It is in pursuit of them that we see, in cool weather, the swallow incessantly skimming over the surface of ponds and brooks; and their thus early hovering over water has strengthened the idea of their having lately emerged from their watery abode, where they are supposed to have lain dormant during the winter. But they are driven by necessity to feed on the gnat. Like the swift and martin, their more favourite food is a small beetle of the scarabæus kind, which, on dissection, I have found in far greater abundance in their stomachs than any other insects.

The tumid state of the testes and ovaria sometimes comes on prematurely, and in the same manner sometimes subsides. When this happens, swallows and martins desert their nestlings, and leave them to perish in the nest. The economy of the animal seems to be regulated by some external impulse, which leads to a train of consequences. When this change in the testes and ovaria takes place, the bird becomes impelled by a stronger principle, that is, the desire of self-preservation. This sometimes happens when they produce a very late hatch. A pair of martins hatched four broods of young ones in the house of a tradesman in this place in the year 1786. The latter brood was hatched in the early part of October. About the middle of the month the old birds went off, and left their young ones, about half fledged, to perish. The pair returned to the nest the 17th of May 1787, and threw the skeletons out.

Thus scarcely a winter passes but we hear of a nest of robins, hedge-sparrows, and some others of the smaller birds. We have been informed by Pennant, and it has been noticed also by others, that the cuckoo has been heard to give his song early as so the middle of February, two months sooner than the usual time. The same deviation from the ordinary course of nature, which prematurely occasions the pairing of

our domestic birds above mentioned, proves the stimulus, I conceive, to certain unseasonable migrations, and accounts for the irregularity first noticed. The same argument is of course applicable to the premature appearance of any other migrating birds. The month of March sometimes affords us warm weather for several successive days. At this time I have often seen the snake basking under a hedge. The lizard, too, has been invited from his cold retreat; but never could I see the swallow or the martin, although I have taken every opportunity of looking for them during the transient sunshine, and made diligent inquiries of others. At the further advancement of spring, often in April, when, from the long prevalence of north-easterly winds, the weather becomes unseasonably cold, and even frosty, swallows, martins, and other early migrators appear among us. But they soon experience the hardships of an inhospitable reception; the insects that should afford them food being still in a state of torpor in their wintry recesses; and, unless called forth by some agreeable change in the air, the unfortunate birds perish for want of food. This I have known happen during an inclement spring, and have picked up starved martins under their nesting places, and willow wrens, which have perished under hedges, through a want of succours.

Unlike the migrating birds that winter with us, of which I shall speak in a subsequent part of this paper, the spring or summer birds do not possess the disposition to change the scene and seek a more genial clime, when this country is so overspread by frost as to deny them their common supplies. This, I imagine, will admit of an easy explanation. The winter birds require nothing here but food and shelter. Our summer visitors come for more various and important purposes. Had they, like the former birds, been endowed with a disposition to wander on certain changes of the atmosphere, the great design of their migration, as it must have proved fatal to the business of incubation and the rearing of their young, would have been frustrated. It may be worthy of remark, that both the summer and winter migrating birds are, on their arrival here, well received by the domestic natives, and neither create quarrels nor excite fears. The redstart builds its nest in the same tree with the titmouse, and the redwing feeds peaceably in the same meadow with the starling.

[To be continued.]

VIII. *Observations on the Mesembryanthema barbata.* By
A. H. HAWORTH, Esq. F.L.S. &c.

To the Editors of the *Philosophical Magazine and Journal.*
Gentlemen,

HAVING recently had occasion to reconsider the remarkable plants which compose the section *Barbata* of the extensive genus *Mesembryanthemum*, added one new species to the group, and detected an error in nomenclature respecting an old one; I send you hereunder an amended account of the whole section and its botanical characters; which, perhaps, may be acceptable to the next Number of your valuable Miscellany; and I remain, gentlemen,

Your very respectful correspondent,

Chelsea, July 20, 1824.

A. H. HAWORTH.

MESEMBRYANTHEMUM. Sectio BARBATA.

Sectionis Characteres.

Suffrutices 2-11-entales plusve, papulosi, foliis apice radiatim stellato-barbatis.

Specierum Characteres.

barbatum. M. (The bearded, bushy) erectum: ramulis effuso-decumbentibus, foliis remotiusculis patentibus apice sub-sex-radiatis, calycinis laciniis subæqualibus. *Mesemb. barbatum*, α , *Linn. Sp. Pl.* 691.—*Dillen. Hort. Elth. fig.* 234. *Bot. Mag. t.* 70. *M. stelligerum.* Nob. in *Synops. Succ. pl. &c.*

Obs. Finding this plant, communicated to me by Professor Williams, from the Botanic Garden of Oxford, to be the original *M. barbatum* of Linnæus; and at the same time being my *M. stelligerum*; I avail myself of this opportunity of rectifying the error, which may perhaps be the most appropriately done by the transposal of the names of the plants, as here adopted.

stelligerum. M. (The bearded, procumbent) ramis procumbentibus elongatis, foliis remotis semierectis apice subquinque-radiatis; calycinis laciniis præinæqualibus.—*Mesemb. barbatum.* Nob. in *Synops. Succ. exclusis synonymis.*

Obs. Priore omnino debilior, sive procumbens, ramis longe paucioribus longioribus, foliis remotioribus magisque erectis.

intonsum.

intonsum. M. (The black-bearded) ramulis erecto-decumbentibus effusis hirtulis, foliis apice sub-decem-radiatis; calyce barbâ nigrâ cincto.

Nova species, a Capite Bonæ Spei. Florebat in regio Horto Kewense, A.D. 1824, Julio mense.

Obs. Variat

α. *rubicundum*, floribus rubicundis, terminalibus solitariis.

β. *album*, floribus niveis nitentibus, morientibus pallidissime roseis.

Obs. Flores breviter pedunculati, pedunculis hispidis ebracteatis, setis albis erectis. *Calyx* 5-fidus turbinatus inferne hispidus, setis patentibus albis, tunc late barbâ validâ nigrâ cinctus, setis nigris subulatis expansis. *Flores*, A. M. ad solem ardentem solum expansi, post illos Mesem. barbati et minores. *Folia* in ramorum apices subconferta, semierecta plusve, pallidiora quam in prioribus et acutiora, basi sæpe incipienter ciliata; undique ad lentem papulis setulâ albâ adpressâ finientibus.

Distinguitur optimè hispidis ramulis, calycisve nigredine barbæ.

stellatum. M. (The small-bearded) foliis (ramulisque brevibus grossis) cæspitosis canis crassis papuloso-scabris, apice multiradiatis, basi ciliatis; pedunculis calycibusque 6-8-fidis hirsutis.—*M. stellatum*. *Pl. Grass.* 29, cum icone.—*Nob. in Revis. Pl. Succ.* 191.

Rarius, et in æstu intenso solum floret.

densum. M. (The dwarf-bearded) densissime cæspitosum: foliis papuloso-scabris, apice multiradiatis, basi subciliatis; pedunculis calycibusque 6-fidis hirsutissimis, caudice senili præcrasso ramuloso brevissimo.—*M. densum*. *Nob. in Synops. Succ. &c.*—*Bot. Mag.* t. 1220.

Obs. Flores rarissimi: æstu intenso solum vidi, quoque solum bis.

IX. Notices respecting New Books.

THE First Part of the Philosophical Transactions of the Royal Society for 1824 has just appeared, and the following are its contents:

The Croonian Lecture. On the internal Structure of the Human Brain, when examined in the Microscope, as compared with that of Fishes, Insects and Worms. By Sir Everard Home, Bart. V.P.R.S. — Some Observations on the Migration

tion of Birds. By the late Edward Jenner, M.D. F.R.S.—On the Nature of the acid and saline Matters usually existing in the Stomachs of Animals. By William Prout, M.D. F.R.S.—On the North Polar Distances of the principal Fixed Stars. By John Brinkley, D.D. F.R.S. &c. Andrew's Professor of Astronomy in the University of Dublin.—On the Figure requisite to maintain the Equilibrium of a homogeneous Fluid Mass that revolves upon an Axis. By James Ivory, A.M. F.R.S.—On the Corrosion of Copper Sheeting by Sea-water, and on Methods of preventing this Effect; and on their Application to Ships of War and other Ships. By Sir Humphry Davy, Bart. Pres. R.S.—A finite and exact Expression for the Refraction of an Atmosphere nearly resembling that of the Earth. By Thomas Young, M.D. For. Sec. R.S.—The Bakerian Lecture. On certain Motions produced in Fluid Conductors when transmitting the Electric Current. By J. F. W. Herschel, Esq. F.R.S.—Experiments and Observations on the Development of Magnetical Properties in Steel and Iron by Percussion: Part II. By William Scoresby, Jun. F.R.S. E. &c. Communicated by Sir Humphry Davy, Bart. Pres. R.S.—On Semi-decussation of the Optic Nerves. By William Hyde Wollaston, M.D. V.P.R.S.

Recently published.

Observations on the Re-building of London Bridge: demonstrating the Practicability of executing that Work in three flat elliptical Arches of Stone, each two hundred and thirty feet Span: with an Examination of the Arch of Equilibrium proposed by the late Dr. Hutton: and an Investigation of a new Method for forming an Arch of that Description. Illustrated by Seven Plates and other Figures. By John Seaward, Civil Engineer.

The Green-house Companion: comprising a general Course of Green-house and Conservatory Practice throughout the Year; a natural Arrangement of all the Green-House Plants in Cultivation; with a descriptive Catalogue of the most desirable to form a Collection, their proper Soils, Modes of Propagation, Management, and References to Botanical Works in which they are figured. Also, the proper Treatment of Flowers in Rooms, and Bulbs in Water Glasses.

ANALYSIS OF PERIODICAL WORKS ON NATURAL HISTORY.

Curtis's British Entomology.

No. 7. contains the following subjects:

Pl. 27. *Aphodius villosus*. From an unique specimen taken by the author upon Newmarket Heath. With the insect is figured the beautiful and local
Anemone

Anemone Pulsatilla from the same habitat. — Pl. 28. *Acanthosoma hæmorrhoidalis*. A new genus proposed by the author for those species of *Pentatomæ* with only two joints in the tarsi, and having a keel beneath. — Pl. 29. *Sarothripus ramosanus* (Branched Sarothripus). A new genus of Moths selected from the extensive family of *Tortricidæ*. The length of the proboscis, the slender palpi and the brush upon the fore legs are admirable characters to distinguish this natural little genus from those with which it has so long been united. The species figured is new to this country, but the remainder of the genus have been long well known. — Pl. 30. *Xyela pusilla*. Not only a rare but most remarkable insect; discovered by the author to be an inhabitant of Britain. Dalman first noticed it in the Stockholm Transactions; and Klug, we believe, has also inserted it in his Monograph upon the *Tenthredinidæ*. It is a most valuable acquisition to the Entomologist, since it unites most beautifully the *Tenthredinidæ* (*Tenthredo* Linn.) with the *Uroceridæ* (*Sirex* Linn.).

The Botanical Magazine. No. 450.

Pl. 2495. *Sida aurita*.—*Conanthera bifolia*.—*Laurus aggregata*; “foliis perennantibus ovatis acuminatis triplinerviis subtus glaucis, pedunculis simplicibus axillaribus aggregatis, bracteis scariosis ovatis concavis:” a doubt is expressed whether this may not belong to the genus *Tetranthera*.—*Canna edulis*.—*Aspidistra lurida*; Bot. Reg. 628.—*Wulfenia carinthiaca*.—*Psidium cattleianum*: a fine figure of this species of *Guava*, together with an illustration of the character of the genus, was given in Mr. Lindley’s *Collectanea*.—*Sarcophyllum carnosum*.

The Botanical Register. No. 113.

Pl. 809. *Amaryllis ignea*, “umbellâ 6-florâ, perianthii laciniis in tubo cylindraceo convolutis, pedunculis perianthii nutantis longitudine, stylo exserto, stigmatibus simplicissimis;” a most beautiful plant sent from Chili by Lord Cochrane. Mr. Lindley has referred this plant to the old genus *Amaryllis*, which, he remarks, “contains the rudiments of several genera, but the principles upon which they are to be separated remain to be ascertained.”—*Oxalis Plumieri*.—*Azalea indica*, received from China in 1819. An arrangement is added of the varieties, spring and autumnal.—*Cineraria speciosa*, “racemo simplice, foliis reniformibus denticulatis; petiolo inflato, caule simplice folioso, bractea in medio pedunculi, floribus cernuis.”—*Chlorophyllum Orchidastrum*, “2-pedalis, foliis lanceolatis acuminatis à basi stricto patentibus, paniculâ ramosâ strictâ multiflorâ, ramis glabris.”—*Ornithogalum virens*, “racemo spicato multifloro, foliis lineari-lanceolatis debilibus ad apicem breviter teretibus acuminatis, sepalis patentibus, staminibus alternis bidentatis, bracteis floribus longioribus:” a new species from South Africa. — *Hedysarum ascendens*. — *Narcissus gracilis*; “12-18-uncialis, foliis lineari-subulatis canaliculatis, scapo terete 1.2-floro, ovario inflato, flore sulphureo.”—(Sabine MSS.) Under this head it is remarked by Mr. Lindley that “the whole genus *Narcissus* requires to be revised with a judicious but severe hand. It may then be discovered that the number of genuine species is very few; and that the individuals which it has become the fashion to call species, are varieties capable of being so distinguished. This we have reason to know is also the opinion of Mr. Sabine, who has probably examined a greater number of plants of this genus than any other person. It will also, we think, be decided, that in most instances Mr. Haworth’s genera are the species, and such of the same ingenious writer’s species as can be distinguished from each other the varieties, of *Narcissus*.”

X. *Proceedings of Learned Societies.*

ROYAL ACADEMY OF SCIENCES OF PARIS.

March 1.—**T**HE Minister of the Marine transmitted some specimens of the coal which had spontaneously taken fire in the arsenal of Brest. He solicited the Academy to investigate the cause of the phænomenon.—M. Paulet presented his manuscript translation of the History of Plants by Theophrastus.—M. Cuvier read a Memoir entitled “A new Examination of a Fossil Animal from the Schists of Solenhoffer, which appears to belong to the Class of Reptiles, and to which the Name of Plerodactylus has been given.”—M. Jomard read a note on the Discoveries recently made in Africa.—M. Becquerel read a Memoir on the Magnetic Actions produced in all Bodies by the Influence of very powerful electric Currents.—M. Paixhaus gave an account of the experiments lately made at Brest on his new system of artillery.—M. Fresnel, in the name of a Commission, made a Report on an improvement of Saussure’s hygrometer proposed by M. Babinet.

March 8.—M. Bulle, of Besançon, transmitted a manuscript Memoir, entitled *Système rotatif rayonnant*.—M. Bussy described the means he had employed for the liquefaction of sulphurous acid gas.—Mademoiselle S. Germain presented a Memoir, in manuscript, on the Effects which the variable Thickness of sonorous Plates produces on their Vibrations.—M. Pouillot presented an Essay on the Oscillations of the Waters of the Ocean.—M. Poncelet, Captain of Engineers, presented a manuscript work, entitled “On the Centres of harmonic Means,” supplementary to his Treatise on the projective Properties of Figures.—M. Desfontaines made a very favourable Report on the Memoir of M. Auguste Saint-Hilaire, entitled “A Monograph of the Genera *Sauvagesia* and *Levradia*.”—M. Moreau de Jonnes read some New Researches on the *Trigonocephalus fer de lance*, or great Viper of the Antilles.—M. Cagniard de la Tour deposited a manuscript Account of his new Researches on Carbonic Acid Gas and the other aëriform Substances which he has obtained in a liquid State. He exhibited several products of his experiments.—M. Dulong, in the name of a Commission, made a Report on the Method of measuring the Power of Bodies to conduct Electricity proposed by M. Rousseau.

March 15.—M. Payen transmitted an Analysis of Tupinamba Root.—M. Bussy announced that the means by which he had succeeded in liquefying sulphurous acid gas, had also

enabled him to liquefy chlorine, cyanogene, and ammonia.—M. Moreau de Jonnes exhibited the young in the state immediately prior to birth of the *Trigonocephalus fer de lance*.—M. Fresnel, in the name of a Commission, made a Report upon an instrument which M. Thilonier had originally designed for the fabrication of mirrors for telescopes, but which he had also applied to the formation of the parabolic and elliptic mirrors of copper employed in experimental philosophy: in this respect the Memoir appeared worthy the approbation of the Academy.—M. Geoffroy Saint-Hilaire read a Memoir on the Osseous System, as affording the most certain indications of zoological affinities, and on the presumed causes of its superiority in that respect.—M. Latreille read an extract from his Memoir on the Geography of central Africa.—M. Mongez commenced reading a Memoir on the Trees called by the Romans *Citrus* and *Citrum*.—M. le Baron Bliass read his Researches on the Theory of Sound and of Vibrations.

March 22.—The Minister of the Interior communicated to the Academy a Report by the Sub-Prefect of Embrun, containing Observations made during a journey to Chamouni.—M. Magendie communicated the results of his experiments on the sense of smell. He announced that this sense is not entirely destroyed by the division of the olfactory nerve: he described also the various effects which result from the division of the fifth pair of nerves.—M. Freycinet read a letter from M. Duperry, dated Otaheite, in which that officer announced the discovery of four new islands near the Perilous Archipelago.—M. Percy made a Report on a new Method of destroying the Stone in the Bladder, proposed by Dr. Civiale.—M. Gay-Lussac read for himself and Dr. Liebig a Memoir on the Fulminate of Silver.—M. Serulas, pharmaceutic chemist, read a Memoir on a new Compound of Iodine, Azote, and Carbon.

March 29.—A Note by M. Becquerel was read, in which he explained in what manner, by means of an extremely sensible apparatus, he had succeeded in determining the electro-motive actions which take place at the moment when acid and alkaline solutions come into contact with any metal; and likewise those which take place when a liquid is interposed between two metals.—M. Mongez concluded the reading of his Memoir on the *Citrus* of the Romans.—M. Fouilhoux read a Memoir entitled “Anatomical and Physiological Remarks on the Ganglionic System.”—An abridged Analysis of a Memoir by M. Roche, on the Rotatory Motion of Solid Bodies, was presented to the Academy.—M. Poinsoit mentioned that he had completed a work which contained several theorems recently announced by him.

The Academy concluded this sitting by going into a secret Committee for several objects of internal administration; and in particular for the consideration of *some arrangements necessary to expedite the publication of their Memoirs.*

April 5.—M. James Leroy claimed the priority of invention of the instrument above mentioned, for effecting the destruction of stones in the bladder.—M. Séligne presented an achromatic microscope of his invention, which was referred to a Commission.—M. de Humboldt gave some new information of MM. Boussingault and Mariand de Rivero, who continue to explore the environs of Bogota with equal zeal and success.

XI. *Intelligence and Miscellaneous Articles.*

ASTRONOMICAL DISCOVERY.

To the Editors of the Philosophical Magazine and Journal.

Gentlemen,

I HAVE this moment received a letter from a distinguished astronomer on the continent, announcing a very happy and brilliant discovery, or invention, by M. Bessel, for determining the accuracy of the position of his meridian circle. It is well known that the method of observing *by reflexion* has been, for nearly half a century past, practised on the continent; although but recently introduced into this country. In this method, the observations themselves are made the test of the position of the instrument. But M. Bessel's inquiries were directed to some mode by which he might be enabled to detect any flexure in his instrument, *without* astronomical observations; and, of course, in any state of the atmosphere, whether cloudy or otherwise. This question was obviously reduced to the finding of two points, which, being seen from the centre of the meridian circle, are exactly 180° distant. These points he determined by the method given by M. Gauss in M. Schumacher's *Astron. Nach.* No. 43, and from the property of the telescope there alluded to.

As M. Bessel's method will be fully explained in one of the ensuing Numbers of M. Schumacher's Journal, and as I have not time at present to be more explicit, I shall now only give you an outline of the plan. M. Bessel places two telescopes (each furnished with micrometer wires) in the two apertures of the building, with their object-glasses turned towards each other: one on the north, and the other on the south side. Let us call these telescopes A and B. He then takes the glasses out of the meridian circle, so that he might see (through the tube of the instrument) with the telescope A, the intersection of the

wires in the telescope B; and adjusts the two telescopes A and B, so that the intersection of the wires in each might coincide. In order to render this operation more easy, the wires in one of the telescopes formed a right angle; and in the other, an angle of about 10° . This being effected, he puts the glasses again into the meridian circle, and measures, with the circle, the angular distance of the points of intersection: which, by Gauss's method, must be exactly 180° ; and which, if found more or less, will give the quantity and direction of the flexion. It may perhaps be imagined that, in order to do this correctly, the points of intersection in the wires, and the centre of the meridian circle should all be in the *same* straight line; a condition that would be very difficult to obtain. But, this is by no means necessary, since all the rays are parallel; and the only thing required is, that you *can see* the points of intersection *through* the meridian circle. This will be evident by reading M. Gauss's paper.

The event has fully answered the ingenious idea: and the method gives a precision hardly to be obtained in any other way. It will also determine the zenith point of the instrument without inverting it. This method is indeed the more valuable, since it can be applied at a time when (on account of the weather, or from other circumstances) no observations can be made. It, in fact, saves the astronomer the troublesome operation of observing by reflexion; and gives the results with greater accuracy.

I am, gentlemen, your obedient servant,

Gray's Inn, July 28, 1824.

FRANCIS BAILY.

NEW LUNAR TABLES.

The new tables of the moon by M. Damoiseau have at length reached this country; and their contents are highly honourable to the author. They are entitled, *Tables de la Lune formées par la seule Théorie de l'Attraction; par M. le Baron de DAMOISEAU, Lieutenant-Colonel d'Artillerie en retraite, Chevalier des Ordres Royaux de Saint-Louis et de la Legion d'Honneur, Membre adjoint au Bureau des Longitudes.* We have given these titles at full length, as they are equally honourable to the author, as to the Government which pays so much and such deserved respect and attention to distinguished merit*. This is the third set of lunar tables which the French Board of Longitude has edited within these last eighteen years: and already another new set is forming by

* The Royal Academy of Sciences has recently bestowed on M. Damoiseau the prize medal, on account of his investigations relative to Encke's comet.

MM. Carlini and Plana. The present tables, as their title imports, are founded entirely on the theory of gravitation; and are a proud monument to the genius of our immortal Newton. The equations depend wholly on *mean* motions, similar to the tables of Clairaut: and, from the list of 50 comparisons at the end, they appear to be deserving of the highest credit.

We regret, however, to state that these tables are arranged according to the centesimal division of the quadrant, and the decimal division of the day: which renders it necessary to *reduce* the result to the sexagesimal notation, and to the civil mode of reckoning time, before they can be of any use to the public. We are much surprised that the French will persevere in arranging some of their best tables in this manner: since it only entails double trouble on the computer. If any *decimal* notation at all is required for the convenience of computing the equations, it would be much better to divide the *degree* into decimal and centesimal parts; and this would prove rather a convenience than otherwise to the computers. The *degree* would be the unity of comparison, and would gradually lead to the abolition of the use of *signs*. But the present arrangement has nothing in common with that which has been so long established; and is moreover continually leading the computer into errors. At all events, if the French *will* persevere in the use of the centesimal division, *they ought to adopt a new set of characters for expressing their degrees, minutes, and seconds*; and not usurp those in general use, which denote quantities totally different, and thus lead to endless confusion.

A LETTER FROM MR. J. RITCHIE, THE LATE AFRICAN TRAVELLER,
TO A FRIEND IN ENGLAND.

My dear M.,

Tripoli in the West, Jan. 21, 1819.

I have not forgotten my promise of writing to you before I left Tripoli, whatever you may have thought from the length of time that I have deferred its performance. I believe the moment of my departure will be soon approaching; and, although I have remained at this place much longer than I expected, it is a delay which I cannot regret, as it has afforded me an opportunity of acquiring some knowledge of the language, and of making excursions in the neighbourhood which have given me a more just idea than I before had of what will be wanting in the course of my journey. We have been able also to collect a number of objects in natural history, which I hope will prove interesting to our friends in England, and convince people (Sir J. Banks in particular) that the obstacles which they supposed to interfere with all researches of this nature

nature in Africa, are not met with at least in this part of the country. Dupont has prepared more than 100 birds, and I have made a considerable collection of reptiles, fishes, shells, insects and plants. I have two specimens of the Effah, a poisonous snake not uncommon here, but which with several other reptiles I cannot find to have been described by Cuvier.

The Chameleon is very common in this country; when I caught the first, I observed distinctly that its property of changing its colour depended on the exertion of a voluntary power; and I was of course rather annoyed to find, on consulting my books, that the same remark had already been made.

A few days ago, Dupont found a nest of Brachini, the whole of which he took prisoners. No less than a thousand of them are set aside for England, and of the rest we intend forming a colony in our garden. I am now making a few experiments on the substance which they emit when they crepitate, but do not know whether I can collect enough to arrive at any conclusion. It made Dupont's fingers entirely black when he took them; it is neither alkaline nor acid according to the ordinary tests, but is soluble in water and in alcohol.

It is only within these few days that the botany of the country is becoming interesting, and at present every day makes it more so.

I have just heard that the French Government has determined to attach a naturalist to each of their ships of war, and that orders have been received by all their Consuls to afford every facility to these gentlemen in their researches.

I hope Great Britain will not be behind her rival in endeavouring to promote science, and I anxiously hope to hear upon my arrival in Europe that an efficient School of Natural History is formed or to be formed in England. My exertions shall certainly not be wanting to contribute towards rendering our national museum worthy of the country which possesses it. The French Government has, in addition, issued orders to their Consuls to collect and send home for the Paris Museum specimens of the animals and plants of the countries in which they respectively reside. I trust that we shall also begin to make some use for scientific purposes of our political and commercial preeminence abroad. There is no obstacle to the finest collection in the world being formed in England, if we knew how to profit of the advantages we possess. The natural history of our Indian possessions is almost unknown, and, so long as there exists in England no school of natural history, similar in its plan to the *Jardin des Plantes*, must continue

tinue to be so in a great measure. I hope that the active steps now taken by the French and other Governments will awaken the British legislature to a sense of what we throw away by an ill-judged œconomy. London may be the metropolis of commerce, but it will never be that of science until it possesses the advantages of a school of natural history, with a truly national museum, menagerie and botanic garden, and a school for mathematical and physical science on the footing of the French *Ecole Polytechnique*. I could have sent home, during the time I have remained here, many additions to a menagerie; but if they were to get to England, there is no place to put them in; and besides, I doubt even whether, under the actual management of the British Museum, the expense of their conveyance would be paid.

My instruments have arrived here in pretty good state, that is, with only two accidents, which, considering the number of things, I do not think more than I might have expected. One of these losses is Six's thermometer for indicating the maxima and minima of temperature. I have, however, written for another from England, which if fortunate I may get before I leave this place, as the Bey of Fezzan will be yet six weeks or two months before his preparations are finished. The other accident was Fortin's barometer, which Dupont let fall on board the ship in which we sailed from Malta. I have however since my arrival repaired this loss to my satisfaction.

I cannot tell you so much about my plans as I could before leaving Europe. In the first instance, I shall go with "Mahammed il Muckné" the Bey of Fezzan, to Fezzan, and afterwards proceed with him in an expedition which he is on the point of undertaking against Waday to the south-eastward. This is the same country which is called Bergou in the maps. My subsequent motions will entirely depend on circumstances.

I have had two accessions to my party since I saw you. One is Lieutenant Lyon of the *Albion*, the admiral's ship at Malta, an officer who draws very well, and is an exceedingly well-informed young man. The other is John Belford, a carpenter from the Maltese Dockyard, who turns out to be a very steady and useful man. I intend to attach four Africans to the party. Two of these are Mustapha, a native of Tripoli, formerly one of the English Consul's Dragomen; and Hassan, a native of Fezzan, who speaks the languages of Bomou and Haoussa. I have had very numerous offers from persons both at Malta and here, who were willing to accompany me. Indeed I should have no difficulty in finding two or three hundred volunteers, as a day hardly ever passes without some applications.

If you happen to be in England on receiving this, pray give my kind remembrances to your father and friends generally; and believe me to be, with sincerest wishes for your happiness and welfare,

Your faithful friend,

J. RITCHIE.

ACTION OF AMMONIA ON METALLIC COPPER.

Dr. Macculloch has observed, that metallic copper dissolves rapidly in solution of ammonia at a boiling heat; the water being decomposed during the process, its oxygen united to the copper, and its hydrogen evolved in the gaseous form. He suggests the application of this process to the purpose of *colouring* gold trinkets, as it is called, or dissolving out to a certain depth the copper of the alloy they consist of, so as to leave a coat of pure gold on their surface.—*Brewster's New Journal*, vol. i. p. 75.

IMPERMEABILITY OF GLASS TO WATER UNDER HIGH PRESSURE.

It was lately maintained by Mr. Deuchar, in a paper in the *Philosophical Magazine*, vol. lx. p. 310, that from the porous nature of certain siliceous bodies, it was extremely probable that the fluids in minerals had been forced through their mass by pressure, and that the water which is found in well-stopped bottles, when sunk to great depths in the ocean, has been forced through the pores of the glass.

The Rev. Mr. Campbell, in a voyage to South Africa, carried out with him two crystal globular bottles hermetically sealed, and made on purpose by Messrs. Pellet and Green, St. Paul's Churchyard. In lat. $14^{\circ} 27'$ N. and to the W. of the Cape de Verd Islands, they were sunk from on board the *Westmorland*, to a depth of 200 fathoms, or 1200 feet, by means of two leads, the one of 22 and the other of 28 lbs. When the rope was brought up, by the exertion of *ten* men, for a quarter of an hour, *the two globular bottles were found empty*. A wine bottle, sent down at the same time, corked and plastered over with rosin, came up full of water, with the cork inverted; five other bottles were full of water, but the corks and rosin of these were in the same state as when let down. Another wine-bottle had the pitch remaining entire on its mouth; but the inside was nearly full of water, in which also the cork was swimming. The water in the inside of the bottles was not more fresh than before its entrance.—Campbell's *Second Journey in Africa*, vol. ii. p. 383, quoted in *Brewster's New Journal*, vol. i. p. 189.

ON THE CUTTING OF STEEL BY SOFT IRON.

At page 336, volume vi. of this Journal, (Philosophical Magazine, vol. lxii. p. 317,) the remarkable fact that soft iron, in rapid revolution, will cut the hardest steel, is described by the Rev. Herman Daggett. This fact does not appear, as far as I am informed, in books; nor have I found that it was before known to practical men. It seems to have been discovered by the Shakers, who are remarkable for the neatness and expertness of their mechanical operations. As it is desirable that the experience of others on this subject should be made known, I will now add, that in June last I saw Professor Robert Hare at Philadelphia execute with a common foot lathe operations similar to those described by Mr. Daggett: they were however less energetic and decisive, as the machine did not produce so rapid a motion as that of Mr. Barnes.

I have, however, since repeatedly seen the experiment succeed, in the most perfect manner, at the manufactory of arms belonging to Eli Whitney, Esq. near this town [New Haven, Connecticut]. As water power is here applied with great facility and energy, a wheel of soft and very thin plate iron, six inches in diameter, and furnished with an axis, was made to revolve with such rapidity that the motion became entirely imperceptible, and the wheel appeared as if at rest. When pieces of the best and hardest steel, such as files, and the steel of which the parts of gun-locks are made, were held against the edge of the revolving soft iron plate, they were immediately cut by it, with a degree of rapidity which was always considerable, but which was greater as the pieces of steel were thinner; pieces as thick as the plate of a common joiner's saw, were cut almost as rapidly as wood is cut by the saw itself. Considered as an experiment merely, it is a very beautiful one, and in no degree exaggerated in Mr. Daggett's account: there is a very vivid coruscation of sparks, flying off in the direction of tangents to the periphery of the cutting; wheel and an intense ignition of the steel, extending for a considerable distance ahead of the section, and on its sides, attends the operation. The impulse against the steel is so strong, that in several instances it was thrown against the opposite side of the room with a velocity that might not have been without danger to a person standing in the way. It may be said, I believe, with safety, that none of the ordinary mechanical operations commenced upon cold and hard steel, will divide it with so much rapidity as this mode of applying soft iron. After all, it is evident that it is only a peculiar method of cutting red-hot, or possibly white-hot steel; for the mechanical force produces these degrees of heat, and it is one

of the best methods of evolving heat by mechanical impulse. The steel of course loses its temper at the place of section, and there only; for the softening extends but a little way, and is limited to a narrow portion, marked by the iris colours known to be produced by heat upon steel.

The iron plate, as Mr. Daggett states, becomes only warm, and wears away, only very slowly; yet it does wear, for the edges are left rough, and the channel of section in the steel exhibits with a magnifier minute striæ or grooves, running in the direction of the wheel's revolution. I know not that there is any reason to suppose any peculiar electrical phenomenon, except that electricity always accompanies heat. It is plain from the important use made of this mode of cutting steel by the Shakers and by Mr. Barnes, that it may be of considerable practical importance.

As a philosophical experiment it is highly interesting: and it remains yet to be shown, why the heat evolved by the impulse should nearly all be concentrated in the steel, and be scarcely perceptible in the iron: neither is it perfectly clear that even ignited steel should be so easily cut by the impinging of soft iron. No smith probably ever thought of attempting to divide steel by applying an iron tool.—*Silliman's Journal*, vol. vii. p. 342.

Results of the Analysis of the principal Brine Springs in the State of New York. By Mr. G. CHILTON.

Process.

1. The water of each bottle, after weighing it and taking its specific gravity*, was slowly evaporated to dryness in a glass basin.

2. The deliquescent salts were extracted from the dry residuum by digestion in alcohol, and separated from each other by converting them into sulphates in the usual way.

3. The mass, after the separation of the deliquescent salts, was dissolved in water and filtered. The carbonate and sulphate of lime left on the filter were separated by muriatic acid, &c.

4. The filtered solution was treated with carbonate of soda, boiled, and filtered; the carbonate of lime left on the filter indicating the quantity of sulphate of lime decomposed.

5. To the last clear solution, neutralized by the addition of

* The water from the deep well at Montezuma was neglected in respect to its specific gravity. One or two of the samples had the odour of sulphuretted hydrogen, which was not regarded in the examination, in consequence of the bottles being imperfectly corked: I think they were those from Montezuma.

muriatic acid, muriate of barytes was added till it ceased to yield a precipitate; the quantity of sulphate of barytes showing that no other sulphate existed in the water.

Table of the Results reduced to centesimal Proportions.

	100 cubic Inches. No. 1, Galen. Sp.gr.1.0544.	100 cubic Inches. No. 2, Montezuma. Sp.gr.1.0161.	100 cubic Inches. Montezuma. Deep Well. Sp.gr.—	100 cubic Inches. No. 3, Onondago. Sp.gr.1.0958.
	Grains.	Grains.	Grains.	Grains.
Muriate of soda	2246.05	551.52	2016.33	3780.34
Muriate of lime.....	13.15	21.07	40.75	23.12
Muriate of magnesia	7.90	11.70	9.30	5.78
Sulphate of lime	55.26	36.30	118.20	106.93
Carbonate of lime...	2.63	2.24	.60	5.78
Silex.....	1.30	.60		
Solid matter...	2326.29	622.93	2185.18	3921.85

Silliman's Journal, vol. vii. p. 344.

CAPT. PARLBY'S RIFLE ROCKETS.

To those interested or curious in the important matter of yesterday's (Dec. 13, 1823) exhibition at Dum-Dum, where the first practical experiment of Capt. Parlbys rifle rocket was undertaken by express desire of authority, the result must be most gratifying. The display took place in presence of General Hardwick, Commandant of the Bengal Artillery, who is now on the eve of embarking for Europe, of Colonel Casement, and many civilians and officers, who could not fail to experience a pleasing and proud satisfaction at the complete success of an experiment of which the ingenious and scientific individual has himself just cause for exultation, and his masters good reason to be gratified. The short notice, only a few days since, on which Capt. Parlbys had to prepare, speaks much for the activity and ready resources of the department, which is directed under his sole management.

The range of the rockets from their respective distances of 600, 800, 1000, and 1760 yards, was in general most beautiful; and, in the ultimate result, establishes unquestionably the superiority of Capt. Parlbys rifle rocket. A very small portion of them exploded, from causes attributable, we understand, to the great haste in which at so short a notice they were necessarily prepared. A few were fired from a tube

placed at a no less distance from the target than one mile! one of which, at this amazing distance, penetrated the target; two others ranged in fine parallel lines even over the target, one of these to the distance of 2300, and the other 2400 yards. To the professional man it were needless to offer remarks on the consequences deducible from this successful experimental result in the department of projectiles. The State and service at large can be no less interested on a practical question of this kind, extending, as it does, its importance to the science in general; and our regret is proportionably awakened at knowing that the experiment, submitted so long back to our late Noble Commander-in-chief as 1815, and before the Congreve rocket had reached India, should not earlier have been put to the test.

It is to be hoped that some individual of office, or of the ordnance branch, will publish, for their brother officers, a correct table of yesterday's rocket practice, and that hereafter a comparative trial may be exhibited on the same ground with the Congreve and Capt. Parlby's rifle rocket.—*Calcutta John Bull.*

The following is an accurate account of the range, &c., of the rocket fired by me on the 1st of December, before Major Wood, Capt. Oliver, and Capt. Nicholson, &c.

Length of the tube through which the rocket was fired, 16 feet.—Elevation 18 degrees.—Range to the first graze where the rocket lodged, 1473 yards 2 feet.—Penetration into the ground exactly five feet.

The size of the rocket is that which according to pyrotechnical rules is denominated a $1\frac{1}{2}$ pounder, a leaden ball of the diameter of the mould being that weight; but a rocket of this size, when filled with composition and complete with its head, stick, &c., weighs about 5 pounds 8 ounces.

From the penetration of the rocket into the ground at the distance of 1473 yards from the place from which it was fired, it may be presumed that had the rocket been thrown at a higher elevation, the range would have been extended beyond a mile. The range of the larger rockets is expected to be 3000 yards.

SAMUEL PARLBY, Model Master.

NEW PERIODICAL WORK.

The Lyceum of Natural History of New York have lately published the first number of their "Annals." Its contents are valuable, and evince the ardour of the members of this highly respectable institution, in regard to the natural history
of

of their country. The object of the work is to give publicity to the papers read before the Lyceum, "the preference to be given in all cases to such as tend to elucidate the knowledge of the natural productions of the United States." We understand it is contemplated to publish from four to six numbers in the course of the next twelve months, at from 25 to 37½ cents, or perhaps 50 cents, each; the price depending in a great measure on the number of plates in each number. The price of the first number is 25 cents; it contains four papers, two of which are on botany, one on mineralogy, and one on "a new species of *Cephalopterus*" by Dr. Mitchell, President of the Society.

—————

*Calendar of Flora, Fauna, and Pomona, at Hartfield in Sussex,
from June 1 to July 15.*

June 1. — The Yellow Fleur-de-lis *Iris Pseud-Acorus*, first flowered today. The two Goat's beards begin to be very abundant in the gardens. The fields are at length beautifully bespangled with *Ranunculi*, and here and there with Harebells, which are not yet decayed. *Parus palustris* has young in the nest, as has also *Mecistura vagans*, commonly called Long-tailed Titmouse. The weather is become warm and pleasant, but by no means settled. Swifts* are become numerous, and indeed the whole Swallow tribe are more plentiful again this season than for several years past.

June 2.—*Lychnis Flos Cuculi*, *Tormentilla vulgaris*, and *Potentilla reptans*, in flower in the hedges. In the gardens a yellow reflex Lily, which I take to be *Lilium Pomponium* β of Curtis. It flowers usually at the end of May in my garden. *Trollius europæus*, which flowered at Hale End in Essex at the end of April, is only just come into flower here today.

June 4. — *Crepis Melunensis*† in flower. *Geum urbanum* abundantly in flower; and also a new species (or perhaps var.) of *Carduus*, found by T. F. Forster, Esq. near Bolebroke, last year. *Iris spuria* in flower. The Monkey Poppy is still abundantly in blow, and a great ornament to the garden.

* All the *Hirundines* are now arrived and abundant. They came this year in the following order: the Swallow on the 19th; the Martin May 1; and the Swift May 23, which is very late. They came at once in abundance: sometimes a straggler is seen on the 9th of May.—See Perennial Calendar for every day in the year, published by Harding and Mavor, under the 15th of April.

† A new species brought by me in seed from Melun in France in July 1822. I know not what species to refer it to, and therefore have given it a name from its native place.

June 5.—A single example of *Papaver Rhæas* in flower, though not common yet.

June 9.—*Mimulus luteus*, *Hemerocallis flava*, *Rhododendron ponticum*, *Ranunculus acris plenus*, *R. Flammula*, and *Digitalis purpurea* in flower. Mr. B. M. Forster discovered *Cardamine amara* in blow. Roses begin to abound.—Many prognostics of rain heard today; the peacock squalls; spiders creep on the walls much, and the cock crows all day at unwonted hours. Tooth-ache and pains in the face prevail much.

June 10.—A rainy day has followed yesterday's prognostics. *Papaver dubium* in flower.

June 11.—St. Barnabas.—Commencement of the solstitial period. *Gladiolus communis*? in flower; also yellow *Allium*, and both *Symphitum tuberosum* and *S. asperrimum*; also a hybrid variety.

June 17.—*Malva sylvestris* flowers in parts of Surry and Hampshire.

June 24.—This is the only year I remember when the Scarlet *Lychnis* was not in flower by this day. An old poem assigns it to St. John the Baptist, from its constancy to this day, and my journals for fifteen years confirm the fact.

June 26.—*Lychnis chalconica* just in flower, but not common yet. All the four British species of swallow very numerous. The weather at length warm. *Campanula Medium* begins to blow.

June 27.—The purple Martagon Lily (*Lilium Pomponium* α) in blow, though some plants of the same species did not open their flowers till about St. Swithin's day. Foxgloves begin to abound under the hedges. Strawberries plentiful in the gardens.

June 29.—St. Peter and Paul.—A single flower out on *Crepis barbata*; the general flowering, however, took place a fortnight later. *Anagallis arvensis* begins to flower.

June 30.—*Tropæolum majus* begins to flower. Hay cut in my fields. Cherries and raspberries ripe.

July 1.—*Verbascum Lychnitis*, *Hieracium sylvaticum*. Weather variable.

July 2.—Visitation of the B. V. Mary.—Dog days begin. Weather changeable. *Hemerocallis fulva* just beginning to blow. Garden poppies common.

July 9.—*Oenothera biennis* blows. The solstitial Flora is now in perfection, though later than in most foregoing years. The *Lilium bulbiferum*, which flowered today, used always to be out in June. Much hay spoiled by the wet and uncertain weather. Indian Cress abundant.

July 14.—The vigils of St. Swithin was announced by the most tremendous storms of thunder and lightning ever remembered by the oldest inhabitant of this village. Weather hot and close.

July 15.—St. Swithin. The æstival period begins. Rain early in the day. *Lilium candidum* began to flower; also the white *Papaver somniferum*, *Sonchus cæruleus* β (a variety introduced by T. F. Forster, Esq.) in full blow. Weather warm. *Agrostemma coronaria* plentiful. *Scabiosa atropurpurea* begins to flower.

July 16.—*Campanula rapunculoides* and *Inula Helenium* in flower.

This year presents a very bad show of apples. Pears are more numerous. Strawberries, cherries and raspberries already very abundant.

Hartwell, July 19, 1824.

T. FORSTER.

LIST OF NEW PATENTS.

To John Hobbins, of Walsall, Staffordshire, ironmonger, for his improvements in gas apparatus.—Dated 22d June 1824.—2 months allowed to enrol specification.

To Humphry Austin, of Alderley Mills, Gloucestershire, manufacturer, for certain improvements on shearing machines.—22d June.—6 months.

To John Beuton Higgon, of Gravel-lane, Houndsditch, Middlesex, gentleman, for his improvement or addition to carving-knives and other edged tools.—22d June.—2 months.

To William Busk, of Broad-street, in the city of London, merchant, for certain improvements in the means or method of propelling ships, boats, or other floating bodies.—29th June.—6 months.

To William Pontifex the younger, of Shoe-lane, London, coppersmith and engineer, for his improved modes of adjusting or equalizing the pressure of fluids or liquids in pipes or tubes, and also an improved mode of measuring the said fluids or liquids.—1st July.—6 months.

To John Leigh Bradbury, of Manchester, Lancashire, for his mode of twisting, spinning, or throwing silk, cotton, wool, linen or other threads or fibrous substances.—3d July.—2 months.

To Philip Taylor, of the City Road, Middlesex, engineer, for certain improvements on steam-engines.—3d July.—6 months.

To John Lane Higgins, of Oxford-street, Middlesex, esquire, for certain improvements in the construction of the masts, yards, sails, and rigging of ships and smaller vessels, and in the tackle used for working or navigating the same.—7th July.—6 months.

To William Hirst and John Wood, both of Leeds, Yorkshire, manufacturers, for certain improvements in machinery for raising or dressing of cloth.—7th July.—6 months.

To Joseph Clisild Daniell, of Stoke, Wiltshire, clothier, for his improved method of weaving woollen cloth.—7th July.—2 months.

To Charles Phillips, of Repnor, in the parish of Friendsbury, Kent, esquire, for certain improvements on tillers and steering wheels of vessels of various denominations.—13th July.—6 months.

A METEOROLOGICAL TABLE: comprising the Observations of Dr. BURNLEY at Gosport, Mr. CARY in London, and Mr. V EALL at Boston.

Days of Month, 1824.	GOSPORT, at half-past Eight o'Clock, A.M.				CLOUDS.						Height of Barometer, in Inches, &c.		Thermometer.			RAIN.		WEATHER.				
	Barom. in Inches, &c.	Thermo.	Temp. of Sp. Water.	Hygrom.	Wind.	Evapora- ton.	Rain near the Ground.	Citrus.	Citricum.	Chrost.	Stratus.	Cumulus.	Cumulost.	Nimbus.	LONDON.			London.	Boston.	London.	Boston.	
															8 A.M.	11 P.M.	BOSTON 8 A.M.					
June 26	30.04	59	49.75	55	W.	0.31	0.010	1	1	1	1	1	1	1	57.67	60.60	58	1.50	..	Cloudy	Boston.	
27	30.06	61	54	SE.	0.010	1	1	1	1	1	1	1	57.68	60.60	63	Fine	[3 p.m. Ther. 73.5	
28	29.97	65	56	S.	0.50	1	1	1	1	1	1	1	60.70	62.66	66	Cloudy, heavy rain		
29	29.72	67	56	SE.	0.50	1	1	1	1	1	1	1	62.70	55.66	66.5	Cloudy [thun. p.m.		
30	29.93	64	50.00	55	SW.	.65	0.090	1	1	1	1	1	1	1	55.67	57.61	61	..	.67	Fine, rain p.m.		
July 1	29.90	65	51	SW.170	1	1	1	1	1	1	1	60.68	59.62.5	62.5	Cloudy		
2	29.62	64	60	W.	0.045	1	1	1	1	1	1	1	59.70	60.63	63	Showery		
3	29.69	64	60	NW.	0.075	1	1	1	1	1	1	1	60.66	55.58	63	1.70	...	Cloudy, brisk wind, Cloudy, rain p.m.		
4	29.76	63	50	SW.	0.370	1	1	1	1	1	1	1	60.65	60.62	59	Cloudy		
5	30.02	64	49	SW.	0.210	1	1	1	1	1	1	1	60.65	60.62	62	Fine, rain p.m.		
6	29.90	64	57	S.	0.15	1	1	1	1	1	1	1	60.66	64.61.5	61.5	Cloudy		
7	29.92	59	50.75	65	SW.	0.015	1	1	1	1	1	1	1	66.70	66.67	67	Cloudy	[3 p.m. Ther. 75.5	
8	30.04	67	64	W.	1	1	1	1	1	1	1	66.75	66.64	64	Fine, showery		
9	30.00	70	56	SE.	1	1	1	1	1	1	1	60.72	62.65	65	Cloudy, showery		
10	30.00	64	50	NW.	.40	1	1	1	1	1	1	1	60.73	62.62	65	Fine, [a.m. & p.m.		
11	30.15	63	50	W.	1	1	1	1	1	1	1	60.76	63.70	70	0.10	...	Fine	[3 p.m. Ther. 78.0.	
12	30.10	67	51.00	60	W.	1	1	1	1	1	1	1	63.78	72.65	75	Fine	[& p.m.	
13	30.10	64	55	S.	.80	1	1	1	1	1	1	1	72.77	69.73	73	Tempest		
14	29.95	74	52	S.E.280	1	1	1	1	1	1	1	60.72	62.63.5	63.5	Fine		
15	29.95	68	65	SW.	0.050	1	1	1	1	1	1	1	66.72	60.65	65	Cloudy, rain a.m.		
16	30.12	68	65	SW.	.25	1	1	1	1	1	1	1	64.70	60.62.5	62.5	Fine		
17	30.24	65	49	N.E.	0.020	1	1	1	1	1	1	1	60.69	60.64	64	0.60	...	Fine		
18	30.27	65	48	N.E.	1	1	1	1	1	1	1	60.70	59.62	62	Fine		
19	30.50	61	50.75	48	N.E.	.60	1	1	1	1	1	1	1	59.70	61.63	63	Fine		
20	30.47	63	48	NW.	1	1	1	1	1	1	1	61.70	60.63	63	Fine		
21	30.30	63	49	N.	1	1	1	1	1	1	1	60.70	61.66	66	Fine		
22	30.31	68	50	E.	.80	1	1	1	1	1	1	1	64.75	63.70.5	70.5	Cloudy		
23	30.24	67	50	SE.	1	1	1	1	1	1	1	63.75	60.67	67	Fine		
24	30.00	67	48	W.	1	1	1	1	1	1	1	59.70	60.64	62.5	0.00	...	Fine		
25	29.94	64	51.00	47	NW.	.60	1	1	1	1	1	1	1	59.70	60.64	62.5	Fine		
Averages:	30.04	64.90	50.54	54.2		5.66	1.385	27	21	29	123	14	11					63.9	3.90			1.26

THE
PHILOSOPHICAL MAGAZINE
AND JOURNAL.

31ST AUGUST 1824.

XII. *The Theory of Vegetable Physiology of M. AUBERT DU PETIT THOUARS; or of the Increase of Plants by means of Buds, or fixed Embryos.* By JOHN LINDLEY, Esq.

To the Editors of the Philosophical Magazine and Journal.

Gentlemen,

I WISH to direct the attention of naturalists in this country to a curious theory of vegetable physiology which arose in France several years since, but which has not yet attracted notice here. The author, M. du Petit Thouars, is equally remarkable for the originality of his opinions, and for the dexterity and ingenuity with which he supports them. They are scattered over many separate works, and have been published piecemeal and at long intervals of time; so that even in his own country, where his works are best known, few persons can be found who are acquainted with the precise nature of his theory, or who will take the trouble to consider the plain propositions upon which it is supported, divested of their discursive and deeply metaphysical illustrations.

This theory has always appeared to me to be a most remarkable explanation of most of the phænomena of vegetable increase; and I have for a long time hoped that some notice would have been taken of it in those of our elementary works which are devoted to the subject of vegetable physiology.

Whether the opinions of M. du Petit Thouars are founded on true or false reasoning, it is not necessary now to inquire. They are at least the opinions of a man of high reputation as a botanist and philosopher; they have never been contradicted by any writer of talent, and from their peculiarity and ingenuity are certainly deserving of attention. I therefore have subjoined to this communication the principal propositions connected with the theory, extracted from the latest publication of the author, in which they have all been collected. If it should appear that sufficient interest exists among botanists in this country to induce you to occupy the pages of your

Journal with a continuation of the subject, I will at future opportunities arrange under their respective heads the principal facts and arguments upon which the theory is supported.

I am, gentlemen, yours truly,

Turnham Green, July 26, 1824.

JOHN LINDLEY.

1. The BUD is the first visible moveable point of vegetation. One exists at the axilla of every leaf.

It is manifest in the greater number of *dicotyledonous* plants and of *grasses*.

It is latent in *monocotyledonous* plants, in which it exists only as a vital point.

The leaf therefore is to the bud what the flower is to the fruit and seed.

2. The bud is at first supported by the juices contained in the utricles of the interior vegetable substance or parenchyma. This is the operation by which the parenchyma is reduced to the state of *pith*.

That part is therefore analogous to the cotyledon of the SEED OR SEMINAL EMBRYO.

3. As soon as the bud is formed, it is subject to two general movements.

The one is a motion upwards, or an *aërial* motion;

The other is a motion downwards, or a *terrestrial* motion.

From the first proceed the embryos of leaves,

Analogous to which is the plumule;

From the second proceeds the formation of the new fibres of the wood or bark,

Analogous to which is the radicle.

4. Each of these fibres is formed at the expense of the *cambium*, or of the sap produced by the first fibres and deposited between the wood and bark.

The fibres carry downwards the matter necessary for their own elongation,

Which matter is the *descending sap*.

5. The development of the bud consists in the aërial or leafy elongation of these fibres;

Each of which, attracted by the leafy extremity, carries upwards with it the matter necessary for its own elongation,

Which matter is the *ascending sap*.

6. From this sap are formed two general substances, the woody and the parenchymatous. (Which were long ago recognised by Grew.)

The woody is disposed in fibres which undergo no change.

The

The parenchymatous appears formed, in the outset, of detached particles which unite and form utricles; so that it assists in the process of increase in every direction. This is the only substance which is susceptible of a green colour.

7. The sap is the food of plants.

It is pumped up, in the form of moisture, by the roots, and it becomes exposed to the atmosphere in the leaves.

In the first instance it has a common use; but finally it receives a particular destination according to the kinds of plants and their parts.

It is only carried to the points where it is wanted, so that there is no universal circulation.

Being composed, principally, of the two general substances of which mention has been made, the woody and the parenchymatous, as soon as one of these is employed in the process of vegetation, it is necessary that the other should be disengaged and deposited in the vicinity; so that the application of one substance is the separation of the other.

XIII. *On the Extraction of Selenium from the Residuum of the Sulphuric Acid Works of Lukawitz in Bohemia; and on the Cause of the Odour of Tellurium.* By Professor SCHOLZ, of the Polytechnic Institution of Vienna.*

IN the winter of the years 1821-2, I examined the thick matter which collects in the leaden chambers of the Auerberg manufactory of sulphuric acid at Lukawitz in Bohemia, and which, from its gray colour inclining to red, had excited the attention of M. Schrattenbach, the director of the works, and a very active man, who delights in the promotion of the natural sciences. A few experiments upon it with chemical tests immediately showed that it contained selenium, of which I have now extracted from it several ounces in its purest form. As this residuum was not of such a compound nature as that of the Gripsholm Works, from which Berzelius first extracted selenium, I was enabled to make use of a process much more simple than the one he adopted to obtain that body. The substance was introduced into a tubulated retort, with muriatic acid and a little nitric acid; and nitric acid being added from time to time, was evaporated nearly to dryness on a sandheat. It was now repeatedly lixiviated with boiling water; the solution filtered, concentrated by evaporation, and mixed with a solution of sulphite of ammonia, which had been

* From Schweigger's *Journal für Chemie*, &c. N. R. band viii. p. 231.

prepared, immediately previous to its application, by passing sulphurous acid gas through a solution of carbonate of ammonia. The precipitate thus produced was collected on a filter, and firstedulcorated with cold and afterwards with hot water. On boiling the fluid which had passed the filter, and which had a strong smell of sulphurous acid, nothing more was separated from it, either alone or with further addition. The bulky red precipitate became diminished in a considerable degree on pouring the hot water upon it, and changed in colour to lead-gray, and then most resembled the gray powder which is obtained by exposing the triple-salt of platinum to a red heat. The powder was now distilled in a small glass retort; but it required a considerably greater heat than is necessary for the distillation of sulphur; viz. a dark red heat, until the retort began to soften. In this process I observed the same changes of colour and lustre, according to the various circumstances of cooling and the different modifications of the state of the aggregate mass, as those which have been described by Berzelius. To detail the experiments I subsequently undertook with this new and interesting substance, would, as I obtained no new results, merely serve to confirm the statements of that chemist; which would be the more superfluous, as his well-known exactness and veracity allow no room for doubt. I cannot however agree with Berzelius in arranging selenium with the metals, now that I am acquainted with it from my own observation; but I have given it, in my lectures, a place among the simple inflammable bodies, as they are called, immediately succeeding sulphur.

The sulphur burnt in the chambers of the manufactory at Lukawitz is obtained from pyrites found in the vicinity of that place, and the enormous abundance of which occasioned the establishment of these works. A quantity of the pyrites was sent me as a sample; but they did not differ in their external appearance from ordinary pyrites, nor could our mineralogists here observe any distinguishing characters in them. I assayed them for selenium, but could not discover any; so that it must either occur in them in such small proportion as to escape detection by the usual tests, or in single specimens only, and those which I examined must have accidentally been free from it.

In the course of last winter I had opportunity of confirming, by direct experiments, the supposition of Berzelius, that the smell of tellurium in vapour might be owing to selenium. M. R. von Gersdorf, the principal assayer here, and of equal ability as a chemist and mineralogist, gave me, for further examination, a portion of sulphur which he had obtained by distillation

tion from a great quantity of ore of tellurium (particularly from the foliated ore of Nagyag, with at most five per cent. of the matrix). From this ore, freed by distillation from a part of its sulphur, he has reduced the metal in greater quantity, probably, than it has yet been procured in by others. The sulphur I received from him, the appearance of which already denoted it to contain selenium, yielded, by the process above described, thirty grains of that substance in a state of purity. I regret, that owing to the nature of the material examined, it was not in my power to determine whether all the ores of tellurium, or only certain species or varieties of them, contain selenium; and also that I was unable to direct my attention to the quantity they may contain. It is now ascertained, however, that tellurium derives its odour from selenium; for the pure tellurium reduced by M. von Gersdorf emits while burning, or by partial oxidation during sublimation, merely the smallest indication of that smell, which, since Klaproth's investigation, has been considered as a characteristic of this metal.

Vienna, July 4, 1823.

XIV. *Hints towards the Natural History of the Toad* *.

By WILLIAM FOTHERGILL, *Esq.*

FROM remote antiquity to the present enlightened age, the toad has had the unmerited misfortune to be considered as venomous in no common degree; which has subjected it to every species of cruelty that prejudiced ignorance could inflict. If the following observations, illustrative of its true manners and habits, should have the effect of procuring it better treatment, by proving, not only its innocency, but usefulness in the oeconomy of nature, the writer will reflect with satisfaction on the time devoted to this friendless reptile.

Toads leave the place of their retreat for the winter the first mild weather in the spring, and their first work appears to be the propagation of their species; to accomplish which, they resort to watery ditches, pools, and the weedy margins of lakes: the spawn is extruded from the female in a long string resembling small beads connected by a transparent gelatinous substance; the male sits perched upon the back of the female, and the spawn is impregnated during extrusion. The writer has never been so fortunate as to see him perform the office of accoucheur as related by Demours in the *Memoirs of the French Academy*; but he will not assert that such a circum-

* Some extracts from this paper were given in the *Linnæan Transactions* vol. xiii. p. 618.

stance never takes place : yet if any one attentively considers the structure and position of the hinder legs, he will be convinced of the difficulty, if not impracticability, of bringing them to bear in such an operation. The first part of the string is probably extruded by a peristaltic motion of the ovarium; and when this is of a sufficient length, the female entangles the end by swimming round the stalks of weeds or small twigs, which when once accomplished all the difficulty is over, as she then swims in any direction that may happen, taking care frequently to surround any weeds or stalks of aquatic plants capable of sufficient resistance; and as the male keeps his station during the whole process (which continues several days) their joint efforts in swimming are sufficient for the purpose of delivery. Thus entangling the chain of spawn effects a double purpose, by expediting the extrusion, and securing it from being swept away by the current or any inundation that may take place previous to the eggs becoming tadpoles.

The young fry having assumed their perfect form, leave the water and spread over the adjoining meadows, some years in countless multitudes, and are the favourite food of many birds, and even of such toads as are of sufficient growth to swallow them.

Though incapable of bearing much cold, the toad is impatient of heat, and never of choice takes up its residence for the day in a situation exposed to the rays of the sun, but generally in some dark corner overshadowed by the foliage of tall-growing plants or shrubs, where it patiently waits like the spider in its web, ready to dart its formidable tongue upon any luckless insect that may come near; for during the heat of the day it is rarely seen crawling abroad in search of prey; yet it will greedily seize what casually comes within its reach, and even pursue a little distance, but whether it succeeds or is disappointed (if not disturbed) retreats to its station, and often in a backward direction. Its beautiful eyes stand so prominent as to enable it to see its prey from whatever quarter it may approach. Its tongue when at rest is conical, very elastic and capable of great elongation, and covered with glutinous saliva to which small insects adhere when struck; its basis is fixed just within the anterior rim of the lower mandible, and the apex extended back towards the throat, in which it differs from every English reptile the writer is acquainted with, the frog excepted, which takes its food in the same manner, but, being endowed with superior locomotive powers, does not use its tongue with the admirable dexterity of the toad. In the upper and lower mandible are two protuberances, by means of which it instantly squeezes to death bees and wasps previous to deglutition. Its

Its food is small worms, bees, wasps, spiders, caterpillars, maggots, beetles, and in short insects of almost every description, except butterflies, and even these it will occasionally take when their wings are shortened. Although capable of sustaining long abstinence, when opportunity offers, it is a voracious feeder. To mention one instance may be sufficient. The writer gave a middle-sized toad nine wasps*, one immediately after another; the tenth it refused: this was in the forenoon; in the afternoon of the same day he gave it eight more, the ninth it followed with devouring eyes, but did not strike it.

To see the toad display its full energy of character, it is necessary to discover it in its place of retirement for the day, and, if possible, unperceived, drop a caterpillar, small worm, large fly, bee, &c. within its sight, and it immediately arouses from its apparent torpor, its eyes sparkle, it moves with alacrity to its prey, and the whole reptile assumes a degree of animation quite contrary to its general sluggish appearance: when arrived at a proper distance, it makes a full stop, and, in the attitude of a pointer, motionless eyes its destined victim for a few seconds, when it darts out its tongue upon it, and lodges it in its throat, with a velocity the eye can scarcely follow. It sometimes happens to make an ineffectual stroke, and stuns the insect without gorging it, but never makes a second till the object of its prey resumes motion.

The writer has never succeeded in rendering any so completely domestic as that mentioned by J. Arscott, Esq. in his letter to Pennant; yet he has certainly familiarised several so far as to have reason to believe himself and family were distinguished from strangers. One summer, happening accidentally to remove an inverted garden pot which had a part of its rim broken out, he found a toad had taken up its residence under it; he quietly replaced the pot, and instantly commenced feeding it with every variety of insects he could procure, which, when dropped before the hole in the pot, it would march out and immediately seize, and retire to its hole until a fresh insect attracted its attention. Almost every evening it left its station to ramble about the garden, but uniformly returned early in the morning to its favourite situation under the pot. This was continued several weeks; but happening to have a party who were desirous to see it feed, it appeared unusually shy and restless; in the evening it quitted its place, and returned no more that season. In the succeeding summer either the same toad, or another so like it as not to be distinguished, took up its residence under the same pot, which was diligently

* Wasps, bees, &c. must be deprived of a wing previously to their being dropped before the toad.

fed during the summer; this was continued several years, making its first appearance the latter end of May, and retreating about the middle of September. That this toad distinguished the writer and the persons of his family (who were in the daily habit of feeding it) from strangers, he cannot doubt, as it would permit them to stroke and pat it without discovering much inclination to hide itself from observation. What exit it made was never known.

J. Arscott, Esq. in his letter to Pennant before alluded to, says, "I imagine if a bee was placed before a toad, it would certainly eat it to its cost." This was undoubtedly a mistaken idea, as the *Apis mellifica*, *conica*, *terrestris*, and the *Vespa vulgaris*, are its favourite food, the writer having for many years given them in large quantities to many different toads with perfect impunity, and no otherwise disabled than having a wing cut off to prevent their flying away. When they have struck any of the above insects, deglutition does not immediately take place as in other cases, but the lower mandible remains closely compressed against the upper for a few seconds, in which time the bee or wasp is killed and all danger of being stung avoided. The protuberances in the upper and lower mandible, before remarked, appear to be destined for this office.

A fine toad having taken up its abode in a convenient situation for feeding, some honey was spread on a leaf, and placed at a little distance from it. The honey soon attracted a number of flies and wasps, and it was surprising to see the caution with which it approached the leaf, and its dexterity in striking the insects as they alighted; pleased with its situation and entertainment, it resorted to the same place many days. One morning another toad had placed itself about a foot distant from the former; a variety of insects were dropped one by one between them; their attention was mutually attracted, and they frequently set at the same insect; yet the disappointed toad never discovered the least resentment or vindictive spirit, nor did the writer on this or any other occasion ever observe the least disposition to quarrel with or annoy each other.

Having for many years fed toads with a great variety of insects, it occurred to the writer to try them with the young of their own species. A small one (about three-fourths of an inch long) was procured and dropped before a full-grown toad: as soon as the little victim began to move off, it was eagerly pursued, struck at, and fairly swallowed. This experiment has been frequently repeated with many different toads, with various success, and it must be admitted that more will refuse than devour the young of their own species.

To try their indiscriminate appetite further, some living minnows (*Cyprinus Phoxinus*) were procured, and one of them dropped before a toad: so soon as it began to struggle its notice was attracted, and having approached to a proper distance it viewed it with attention, and after some time made a stroke; but being slippery, it did not adhere sufficiently to its tongue to bring it into its mouth; but the minnow continuing to struggle, the stroke was repeated, and the minnow swallowed. After a few minutes a second was dropped, nearly two inches long, at which some feeble and ineffectual strokes were made; the minnow was taken up alive and put into water. Next morning the toad was observed in the same place; the minnow dropped before it, which it struck at vigorously and fairly swallowed.

One trait in the character of the toad must not be passed over without notice, and that is, its uniformly refusing to feed on dead insects, however recent. To ascertain whether the effects of hunger would not overcome this aversion, a vigorous toad was placed in a large garden pot, and a number of recently dead bees put in along with it, and covered so as to admit air, but prevent the access of any insect large enough for it to feed upon; at the expiration of six or seven days, on examination it was found not a bee had been touched; yet the writer from many years' experience knows that when alive they are a favourite food. It may be alleged that this was not a fair experiment, and that being in a state of unnatural confinement was the cause; but that could not be the reason, as they will generally eat living insects freely after one hour's imprisonment.

About the time the Hirundines leave us, toads retire to their winter quarters, which are in the bottoms of walls, roots of hedges and close bushes, or any situation where they are likely to be protected from the frosts of winter; and some even burrow in the solid ground to a depth which the frost seldom penetrates, not in numbers together like frogs, but solitarily*.

* In the spring the writer has twice had an opportunity of detecting them in the act of emerging from their annual interment. Walking in his orchard, as often as he happened to tread on one particular spot a faint squeak was heard, which being frequently repeated, he was induced carefully to open the ground, and found that a toad had approached so near the surface that the pressure of his foot had given it pain. The second was in a dry open meadow, and discovered by the uttering of the same sort of squeak on treading on one place; and on opening the ground a toad was found as in the first instance.

They burrow backwards, by the alternate motion of their hinder legs, the writer having seen them in the very act.

The uses of the slender billed small birds have been long and deservedly acknowledged in preventing, or at least checking, the noxious increase of many sorts of insects; and it is hoped the unprejudiced reader will now consider toads as able coadjutors in the work, and treat them with that indulgence they are so justly entitled to. Whoever expels them from his premises (the apiary excepted) is driving away useful servants. The writer hopes he has established the character of toads as to their usefulness; and that they are devoid of all poisonous or venomous qualities whatever, he is perfectly satisfied from many years' observation and experience, having handled them in all directions, opened their mouths, and given them every opportunity and even provocation to exert their venomous powers, if possessed of any. In short, he believes them to be the most patient and harmless of all reptiles.

The following observations being connected with the natural history of the toad, may perhaps not improperly follow as addenda.

The substance known by the name of star-jelly or star-shot (*Tremella Nostoc*), found on marshy ground, is the decomposed bodies of toads or frogs, but more particularly the latter, the writer having frequently found the exuvia of the reptile connected with it, and he has also seen the lacerated body of a frog lying on the margin of a lake one day, and the next seen it converted into this substance, the atmosphere at the time being very humid and the weather wet, which appear to be necessary adjuncts to the formation of star-jelly. It may be objected that this substance is sometimes found in places inaccessible to frogs and toads, as the tops of thatched barns, hay-ricks, &c. This is easily accounted for; these reptiles are the food of various birds of prey, and by them carried to those situations to be devoured at their leisure; and if scared in the act, the lacerated toad or frog is left behind, and if the state of the weather and air is favourable to this mode of decomposition, star-jelly is formed. If the weather is hot and dry, they are converted into a hard leathery substance. Frogs in particular are rarely decomposed by the usual process of animal putrefaction.

Pennant says, "The gelatinous substance known by the name of star-shot or star-jelly, owes its origin to the winter mew, or coddly moddy, or some of the kind, being nothing but the half-digested remains of earth-worms on which these birds feed, and often discharge from their stomachs."

It is not contended that this may not in part be true; but no part of the star-jelly the writer has ever seen could derive its

its origin from this source, as neither the winter mew nor any of its congeners ever make any stop, and are rarely seen in his neighbourhood.

Carr End.

WILLIAM FOTHERGILL.

XV. *Some Observations on the Migration of Birds. By the late EDWARD JENNER, M.D. F.R.S.; with an Introductory Letter to Sir HUMPHRY DAVY, Bart. Pres. R.S., by the Rev. G. C. JENNER.*

[Concluded from p. 60.]

I PROCEED now to make some observations on another kind of migration, directly opposite to the foregoing, namely, the return of the spring migrators to their respective *homes*.

The great disproportion in numbers between those species of birds which quit the country in summer, and those that leave it at the autumnal season, has led naturalists to lose sight of the early migrators, and to confine their reflections on the subject to the late ones only. Hence the common observation, that they are *all* driven off through a failure of food or a cold temperature of the air. But seeing that many of them disappear in the summer season, when food is placed before them in the greatest plenty, we must seek for some other cause. If we examine what is now going forward in the animal economy, dissection will point out a change in the testes and ovaria, the very opposite to that which took place in the spring. These parts now begin to shrink*, the disposition for raising a further progeny ceases, and the nuptial knot is dissolved. What inducement have they to stay longer in that country where, I think, it clearly appears their chief object is to multiply their species? This being now effected, they retire to different parts of the globe, doubtless better suited to their general dispositions and wants, when disengaged from parental duties. In many of the migrating species, indeed in the far greater number, the disposition for further incubation, and the season for their procuring a further supply of insect food, cease at the same time. It is pretty evident from the habits of the cuckoo and the swift, that quit us in the summer as soon as their nesting is at an end, that swallows, martins, and those birds that disappear in the autumn, would depart at an earlier season, even though their supplies were to continue, if the rearing of their young were perfected. Indeed, as has been before observed, so strong does this propensity

* I examined a female cuckoo the first week in July, and found the oviduct shrivelled, and all the eggs disposed of.

now and then appear, that it overcomes even the obligation of rearing their young when hatched late in the season, and they are sometimes left in a callow state to perish in their nests. This premature departure, probably arises from a reverse of that stimulus which occasions the too early migration of the spring birds, as has been noticed in a former part of this essay, namely, a change which takes place in organization.

One of the most singular occurrences in the history of migration, is the mode of departure of the young birds from the country where they were produced. It may be conceived that the bird which had once crossed the Atlantic, or any other ocean, might have something impressed upon it that should prove an inducement to its return; but this cannot be an incitement to the young one. The identical bird, which but a few weeks before burst from the shell, now unerringly finds, without any apparent guide, a track that leads it safely to the place of its destination, perhaps in many instances over the widest oceans.

It is well known, that those birds which incubate several times in the course of one summer, forsake their first broods when they no longer require their protection: and being now alienated, they cannot, in their parents, find the guides that conduct their course. As swallows and martins congregate* prior to their departure from us, it may be said that their young, though discarded, may mingle with the common flock, and in this particular instance I am ready to admit that it is probable they may do so; but there are many migrating birds that never either associate with swallows and martins, or join together in flocks, as the nightingale, redstart, and indeed the far greater number. As a striking proof that the parent bird cannot possibly be the guide, in one instance at least, we may point out the cuckoo, whose offspring finds a distant shore in perfect safety, although it could never know the parent to whom it was indebted for existence, and though its existence in numberless instances must have taken place even after the departure of the parent. For the old cuckoos invariably leave us early in July, when many of their eggs are yet unhatched in the nests of those small birds to whose fostering care they

* Swallows and martins congregate on the sunny sides of buildings for the sake of warmth, and not, as it is generally supposed, to hold a kind of consultation previous to their final departure. In the wet summer of 1821, when the air was unusually chilled by the long continued rains, they were observed to assemble, during some intervals of sunshine, for several successive mornings, as early as the middle of July; and in the present year (1822) I remarked the same on some mornings that were unseasonably cold about the middle of August.

are intrusted. Compared with quadrupeds, and some other animals, birds may be considered as acquiring the adult state at an early period, and the young bird, at the time of its leaving us, may be looked upon as possessing power equal to the old one in procuring food, velocity of flight, &c. The parent bird, from having lost that stimulus by the subsiding of the testes and ovaria, which urged it to incubation and detained it here, is now reduced to a condition similar to that of its offspring, both falling into the same habits, and remaining in the same state with respect to organization, until the returning calls of nature urge them to quit that country again to which they are *now* about to depart.

II.

Winter Birds of Passage.

“We have, ’tis hoped, made it pretty evident that summer birds of passage come to and depart from us at certain seasons of the year, merely for the sake of a more agreeable degree of warmth, and a greater plenty of food; both which advantages they procure by an alternate change of climate; but the migration of winter birds of passage, and particularly of fieldfares and redwings, is much more difficult to be accounted for, there being no such apparent necessity either on the score of food or climate, for their departure from us.”—Mr. Catesby, *Phil. Trans.* No. 483.

The winter birds of passage, as they are commonly called, begin to take their leave of us about the same time that the spring migrators are taking wing to pay us their annual visit. As the latter appear among us in gradual succession, so in like manner the former disappear. They are both actuated by the same impulse, the former in leaving, and the latter in coming to this country, namely, the enlarged state of the testes and ovarium. As soon as the stimulus becomes sufficiently felt, they quit their homes in quest of a country better suited to their intended purpose than their own.

That a want of food cannot be the inducement, must be obvious to the slightest observer. When the redwing and fieldfare quit this country, it abounds with that food which they prefer to any other; and at this time they are in the finest condition; the redwings often enjoying their plenty by assembling together on trees, and there uniting their feeble voices, make no unpleasant song*.

* The same thing happens through the winter, whenever the weather has long continued so mild as to allow them plenty of insect food. The starling (and some other birds which have a short note and weak voice) unites with its companions in the spring, and forms a similar concert.

The winter birds (the females at least) may be said to seek a better accommodation, upon the same principle as the poor woman who quits her cottage for the comforts of a Lying-in Hospital. Here, both herself and suckling are for a while supported in that peculiar way which their situations at that time require. For this reason, conceiving it will tend to lessen confusion, I choose to call this country the *home* of the winter birds (though not natives), and the countries from whence they come, the home of the summer birds, looking upon the latter merely as visitors; and let it be recollected how soon the visits of some of them are paid; for, being governed by an unerring principle, they stay to accomplish one great design only, that of rearing their young, and then return.

The countries to which many of the winter birds retire not being very far distant, are better known to us than those to which the summer birds migrate; but I must forbear entering into an inquiry upon this subject, as remote from the design of this paper; and indeed it may be thought I have already, in some instances, digressed too widely from my original purpose.

The migration of the winter birds is less distinctly marked than that of the spring migrators. The snipe, the wild-duck, the wood-pigeon, breed here in considerable numbers; the two latter indeed, particularly the wood-pigeon, are so numerous in summer, that we should hardly be reminded of the migration, did they not pour in upon us in such immense flocks in the winter. They are accompanied by the stock-dove, which I have never known to breed here. The home-bred wild-ducks are easily distinguished by the men who attend decoy-pools, by the meanness of their plumage, when compared to the brightness of those birds which come from abroad. The former are taken some weeks earlier than the latter.

The most conspicuous among the winter migrating birds are the redwings and fieldfares. These are regular and uniform in their appearance and disappearance, and I believe never risk the trial of incubation here, at least I never could hear of a single instance. The food of these birds has in the works of every naturalist I have ever had access to, who had written on the subject, been pointed out as the haw, the fruit of the white-thorn*.

This is an error that has long wanted a correction; for in open weather they take them in very scanty quantities, and

* "The principal food of these birds, while with us, is the fruit of the white-thorn, or haws, which hang on our hedges in winter in prodigious plenty."—Phil. Trans. vol. xlv. p. 435.

feed on the ground on worms and such insects as they can find. Although repeated examinations of the contents of the stomach have afforded the best proof of this, yet there is scarcely any need of calling in its aid in the present instance, as we may be convinced of the fact, by seeing them in flocks feeding on the ground in open fields and meadows. I do not deny their taking the haw and other vegetable food from the hedges; but they do it in so sparing a way, that I have remarked, that redwings and fieldfares died through hunger during the long continuance of frosty weather, while the haws on the hedges were by no means deficient. The occasional departure of these and some other winter birds during a long continued frost, must be very obvious. The greater number disappear soon after its commencement, if it sets in very severely: some few are always left behind and are soon starved, if not fortunately relieved by a thaw. Those that are driven to this necessitous migration, probably pursue a track that quickly leads them out of the reach of frost. Of these flights I shall produce instances, which render it probable that they are able even to outstrip its course.

The approach of intense frost is often to a certainty made known to us by the appearance of a numerous tribe of water-birds, some of which are rare, and seldom show themselves here on any other occasion. We commonly see them three or four days prior to the setting in of very severe frosty weather. This was manifest at the latter end of the year 1794, at the coming on of the severe season that ensued. In the river Severn, about a mile and a half to the westward of this place, were seen and taken many species of water-birds, that generally confine themselves to the more northern regions. Far more pleasant is it to see during the continuance of hard frost, the return of those birds which had left us at the beginning. These are pleasant omens, and most certainly forebode a thaw. The following example shows how soon they catch the first opportunity of again seeking those countries from which they were so lately driven by necessity. The day preceding the thaw, the frost being then intense, a gentleman who was shooting observed a large flock of fieldfares, birds that are extremely common here in milder weather. They were as much untamed as if no frost had appeared in our island. He had the good fortune to shoot one of them, which was brought to me. I found it as fat and plump, and in every respect in as good condition, as if it had remained here undisturbed, and had found provision in the greatest plenty, though it was without a particle of food in its stomach. Its last meal was digested; and the frost still remaining, it could find no
food

food for its present support. Now it is very obvious that this bird, and its companions, must have taken a long flight, and probably in a very short space of time; for the intense frost, that was of such duration and so severely felt here, extended far into the more southern parts of Europe, beyond which they must have resorted for that plenty of food which gave plumpness to the one I examined, and doubtless to the whole flock, from their appearing so wild and vigorous. It clearly appears, that in their flight they exceeded the progress of the thaw, as the northern birds did that of the frost. This thaw, though it was again succeeded by frost, came on very rapidly, and occasioned, by the sudden melting of the snow, those destructive inundations through the kingdom, that will not readily be forgotten.

This account of the fieldfare sets the fact of migration, though from an accidental cause, beyond the reach of doubt. There was no support for it here; the ground was deeply covered with snow, and the intense frost, by its long duration, had destroyed every thing that could afford it succour; it must therefore have taken a long flight from this country, and returned to it again at the approach of temperate weather.

Having already made so many digressions, I cannot add another without offering an apology; but as there is something so like providential design in the order in which the song birds chaunt out their warblings during a long summer's day, I trust the Society will pardon my laying before them the following observations on the subject.

We must observe, that nature never gives one property *only* to the same individual substance. Through every gradation from the clod we tread upon to the glorious sun which animates the whole terrestrial system, we may find a vast variety of purposes for which the same body was created. If we look on the simplest vegetable, or the reptile it supports, how various yet how important in the economy of nature are the offices they are intended to perform! The bird, I have said, is directed to this island at a certain season of the year to produce and rear its young. This appears to be the grand intention which nature has in view; but in consequence of the observation just made, its presence here may answer many secondary purposes; among these I shall notice the following. The beneficent author of nature seems to spare no pains in cheering the heart of man with every thing that is delightful in the summer season. We may be indulged with the company of these visitors, perhaps, to heighten, by the novelty of their appearance, and pleasing variety of their
notes,

notes, the native scenes. How sweetly, at the return of spring, do the notes of the cuckoo first burst upon the ear; and what apathy must that soul possess, that does not feel a soft emotion at the song of the nightingale (surely it must be "fit for treasons, stratagems, and spoils")! and how wisely is it contrived that a general stillness should prevail while this heavenly bird is pouring forth its plaintive and melodious strains,—strains that so sweetly accord with the evening hour!—Some of our foreign visitors, it may be said, are inharmonious minstrels, and rather disturb than aid the general concert. In the midst of a soft warm summer's day, when the martin is gently floating on the air, not only pleasing us with the peculiar delicacy of its note, but with the elegance of its meandering; when the blackcap is vying with the goldfinch, and the linnæus with the woodlark, a dozen swifts rush from some neighbouring battlement, and set up a most discordant screaming. Yet all is perfect. The interruption is of short duration, and without it, the long continued warbling of the softer singing birds would pall and tire the listening ear with excess of melody, as the exhilarating beams of the sun, were they not at intervals intercepted by clouds, would rob the heart of the gaiety they for a while inspire, and sink it into languor. There is a perfect consistency in the order in which nature seems to have directed the singing birds to fill up the day with their pleasing harmony. To an observer of those divine laws which harmonize the general order of things, there appears a design in the arrangement of this sylvan minstrelsy. It is not in the haunted meadow or frequented field we are to expect the gratification of indulging ourselves in this pleasing speculation to its full extent; we must seek for it in the park, the forest, or some sequestered dell, half inclosed by the coppice or the wood.

First the robin, and not the lark, as has been generally imagined, as soon as twilight has drawn the imperceptible line between night and day, begins his lonely song. How sweetly does this harmonize with the soft dawning of day! He goes on till the twinkling sunbeams begin to tell him his notes no longer accord with the rising scene. Up starts the lark, and with him a variety of sprightly songsters, whose lively notes are in perfect correspondence with the gaiety of the morning. The general warbling continues, with now and then an interruption, for reasons before assigned, by the transient croak of the raven, the screaming of the jay and the swift, or the pert chattering of the daw. The nightingale, unwearied by the vocal exertions of the night, withdraws not proudly by day from his inferiors in song; but joins them in the general har-

mony. The thrush is wisely placed on the summit of some lofty tree, that its loud and piercing notes may be softened by distance before they reach the ear, while the mellow black-bird seeks the inferior branches. Should the sun, having been eclipsed with a cloud, shine forth with fresh effulgence, how frequently we see the goldfinch perch on some blossomed bough, and hear his song poured forth in a strain peculiarly energetic; much more sonorous and lively now than at any other time; while the sun, full shining on his beautiful plumes, displays his golden wings and crimson crest to charming advantage! The notes of the cuckoo blend with this cheering concert in a perfectly pleasing manner, and, for a short time, are highly grateful to the ear; but, sweet as this singular song is, it would tire by its uniformity, were it not given in so transient a manner. At length, evening advances—the performers gradually retire, and the concert softly dies away. The sun is seen no more. The robin again sets up his twilight song, till the still more serene hour of night sends him to the bower to rest. And now to close the scene in full and perfect harmony, no sooner is the voice of the robin hushed, and night again spreads a gloom over the horizon, than the owl sends forth his slow and solemn tones. They are more than plaintive, and less than melancholy, and tend to inspire the imagination with a train of contemplations well adapted to the serious hour. Thus we see that birds, the subject of my present inquiry, bear no inconsiderable share in harmonizing some of the most beautiful and interesting scenes in nature.

But let me here remark—how ill would the singing of birds agree with the general appearance of winter—the leafless tree,—the snowy mead,—the frozen rivulet! Yet it must be noticed here, that these rigors, in the midst of this dreary season, are sometimes suddenly softened, and a temperate state of the air succeeds. We are then so enlivened by the transition from extreme cold to a temperature comparatively warm, that we can listen with pleasure to the enfeebled notes of some of the song birds. How admirable the contrivance! There are several birds which have no continued flow of notes, but a kind of chirp only, consisting of some variety of sounds. During a long continued frost, the earth affords many of the feathered tribe so scanty an allowance that they preserve themselves with difficulty from perishing; a sudden thaw takes place,—plenty at once appears, and every crop is filled. 'Tis then we see the redwing and starling assemble in large flocks among elms and apple trees, and, by uniting their voices, produce a song not in the least discordant, but, on the contrary, extremely harmonious. At this time the thrush, and even the

the blackbird, will occasionally afford us a transient song; but it may be observed, that the notes of these birds are rather to be considered as plaintive, than lively. The lark, too, will sometimes mount in the air, beguiled, as it were, by the faint rays of a wintry sun, but his notes are then as poor and feeble as the beams that call him forth. The robin indeed cheers us with his song during the whole of the winter, unless driven off by intense frost, and is the only bird I know, whose notes at this time would fully accord with our feelings, so perfectly do they mingle with the surrounding order of things. The goldfinch, were he now to open his full song upon us, would be as appalling as tones of the owl in the midst of a fine summer's day.

III.

Mr. John Hunter, my late valued friend and honoured preceptor, under whose roof I first caught a gleam of that light which so successfully conducted him through the obscure paths of nature, first demonstrated the different sizes of the testes of birds at different seasons of the year. On a further investigation of this subject, a fact presented itself to me, which may not be unworthy of the attention of this Society, and, as it is in some measure connected with the preceding observations, I have taken the liberty of annexing it.

In those birds that remain but a short time paired with the female, there appears a vast disproportion in the size of the testes, compared with those that live in the connubial state much longer. The cuckoo and the swift point out the fact most obviously. The common brown wren, which remains united with its female from the early part of spring until the autumn, exhibits testes very far exceeding in size either those of the cuckoo or the swift. The cuckoo, although a polygamist, may here be considered in the same point of view as the birds that pair. The time which he devotes to the female being so very short, more so indeed by some weeks than even that of the swift, the testes are formed extremely small in proportion to the size of the bird. I never saw them exceed in size the common vetch, while those of the wren were full as large as a common sized garden pea. The medium weight of the cuckoo is about four ounces and a half, that of the wren but little more than three drachms*. The testes of the swift,

* Ornithologists might easily have given us the weight of a bird with greater precision, by divesting the stomach of its contents previous to the bird being weighed. For example: how very different must the weight of the owl be, which, in its nocturnal flights, had the luck to pick up a mole or two, compared with that which had met with opposite fortune; or of the falcon, that had picked the bones of a leveret, or of the one that was killed with an empty stomach!

which assume a singular oblong shape, somewhat exceed the cuckoo's in bulk, though not so large as those of the wren. I have selected the wren as an example for this comparison, on account of its diminutive size. The testes of all those birds which are capable of producing young more than once in the breeding season, become tumid, as far as I have seen, in the same proportion as those of the wren.

As there are many birds, which, if unmolested, produce but one nest of young ones in the course of the season, it may be asked, why nature should cause as great an enlargement of the testes in these, as those which breed more than once; and why they should exceed in bulk those of the cuckoo or the swift? The answer, I presume, is obvious. Should any ill accident befall the nestlings of the swift when advancing to maturity, the injury would be irreparable, the parent bird being destined to quit the country before another offspring could be reared. The cuckoo is in the same predicament; but the wide dispersion of its young ones (being placed singly in the nests of other birds) gives them such security as almost to preclude the possibility of their general destruction*. But it is not so with those birds which make a longer stay; should similar accidents befall them, they can repair their losses. Nature, as long as incubation could serve their purposes, would keep an accumulation of the proper powers in store, which, in the case of the cuckoo and swift, would be entirely useless.

Whether there be a regular gradation in the size of the testes (that of the bird itself being considered) throughout the whole race, in proportion to the time taken up in pairing, I cannot determine, not having had an opportunity of subjecting the matter to a full investigation. However, I thought the fact already shown of sufficient importance in natural history, to be worthy of communication, as it forms a kind of sequel to Mr. Hunter's paper on the subject.

With due deference to the late Dr. Darwin, I am inclined to think that the opinion he set forth respecting the pairing of cuckoos, was taken up hastily, and that the birds which his friend saw were not cuckoos feeding their nestlings, but goat-suckers, whose mode of nesting corresponds with the relation given, and whose appearance might be mistaken for them by one not perfectly conversant with the plumage and the general

* May not this be offered as another reason why its eggs and young ones are intrusted to the fostering care of so great a variety of birds? It could not have time, during its short stay, to rear so large a progeny; and by no other means could it have placed its numerous brood so much out of the way of danger.

appearance of cuckoos when on the wing. Is it probable that the cuckoo, which is invariably a polygamist, and never pairs, nests, or incubates in this part of the island, should fall into opposite habits in another part?

To recapitulate the substance of my observations. I have first adduced some arguments in support of migration, the fact itself not being generally admitted by naturalists of celebrity, and also against the hypothesis of a state of torpor, or what may be termed the hybernating system. I have represented that the swallow tribe, and many other birds that absent themselves at stated periods, return annually to the same spot to build their nests; and at the same time that any inference drawn from this fact in support of a state of torpor, would be fallacious upon physiological principles. That certain periodical changes of the testes and ovaria, are the inciting causes of migration. I have stated many facts, hitherto, I believe, unnoticed, chiefly with respect to the *cause* which excites the migrating bird, at certain seasons of the year, to quit one country for another, viz. the enlargement of the testes in the male, and ovaria in the female, and the need of a country where they can for a while be better accommodated with succours for their infant brood, than in that from which they depart. It is also attempted to be shown that their departure from this country is not in consequence of any disagreeable change in the temperature of the air, or from a scarcity of their common food, but the result of the accomplishment of their errand, *i. e.* the incubation, and rearing of their young, and the detumescence of the testes and ovaria. That successive arrivals of migrating birds are attributable to the progressive development of the generative system in the male and female; that progressive developments are wise provisions of nature; that premature arrivals and departures are frequently to be accounted for on the same principle; that the departure of the spring migrators is owing to a change in the testes and ovaria, the very opposite to that which took place in the spring; that the departure of the young birds is not guided by the parent, but the result of an unknown principle.

In the second part of this paper, some observations are made on the winter birds of passage; that they quit their homes (this country) in spring, in quest of a country better suited to their intended purpose than their own; that they are actuated by the same impulse in quitting this country that causes the spring birds to come to it, and that want of food cannot be the inducement; that the emigration of the winter birds is less complete than that of the others (the spring migrators); that some species breed here, especially the wild-duck

duck and wood-pigeon; that the redwings and fieldfares are the most regular and uniform in their appearance and disappearance, and most probably never risk the trial of incubation here*; that they quit the country *temporarily* in severe and long-continued frost through want of food, and return to it again at the approach of more temperate weather; that the arrival of water-birds forebodes the approach of intense frost, the usual return of the winter-birds, a thaw; that examinations of the latter prove them to have taken long flights before their return, and sets the fact of temporary migration beyond the reach of doubt.

I have then made a digression, and introduced some observations on the singing of birds; and in a third part, given some additional particulars respecting the different sizes of the generative organs of birds, as they appear at different seasons of the year.

XVI. *Introduction to the Seventh Section of BESSEL'S Astronomical Observations.*

HAVING explained in the preceding section the means which I have employed to give all desirable certainty to the observations for determining right ascensions, I now communicate the methods which I have pursued for ensuring an equal degree of accuracy to the declinations. It was necessary for this purpose to examine both the instrument itself and the refraction; for, if the hope of advancing further than has hitherto been done, by an accurate knowledge of the instrument, be well founded, the refraction must likewise be better determined than by preceding observations. It is well known that the refractions hitherto used in this observatory, have been derived by me from Bradley's observations; but the meridian circle of Reichenbach possesses considerable advantage over the mural quadrant both by the accuracy of single observations, and the possibility of discovering all constant errors; and besides, it admits of any examination which the observer may in future deem necessary; whereas for the Greenwich quadrant the existing number of facts recorded by Bradley in his observations is for ever closed.

I will endeavour to give a general view of the course of this investigation before I enter into the detail of every part. The errors of the instrument which I have determined so as to be

* I must be understood by the word "here," to mean that part of Gloucestershire under my own observation.

capable of being allowed for, are the errors of division, and the flexure of the telescope: on the figure of the wires in the telescope there will be found in the *Journal* numerous observations of α *Ursæ Minoris* both at the ends and the middle of the field; but I have perceived no deviation of them from a right line. I have likewise in vain endeavoured to discover the influence of a change of temperature of the instrument on the line of collimation. I am not aware of the possibility of any other errors of the instrument. The possible errors of computation I have sought in the refraction for the standard temperature of the table and its changes.

These errors are mixed together in the observations, and must be elicited by proper methods; the errors of division have been determined by direct microscopical examination; the flexure was investigated in two different ways by the images of stars reflected from a surface of water. Although it is not necessary, in computing these latter observations, to know the refraction itself, yet its changes must be known, in order *correctly* to compare the observations made at different times. The determination of the changes of refraction must therefore precede; they may be obtained independently of the errors arising from flexure and imperfect division, by not mixing together the observations made in the two positions of the instrument. The errors of division, the flexure and the changes of refraction being known, observations of circumpolar stars will give the refraction for the standard temperature of the tables. I now proceed to the single parts of this investigation.

1. *Examination of the Errors of Division,*

published in the *Phil. Mag.* for May 1824, vol. lxiii. p. 348.

2. *Examination of the Thermometer*

published in the *Phil. Mag.* for April 1824, vol. lxiii. p. 307.

3. *Thermometrical Corrections of Refraction.*

Gay-Lussac's experiments on the expansion of air by heat would render the astronomical investigation of this subject unnecessary, if the atmospherical air were always perfectly dry; but the aqueous vapour mixed with it produces a change of refraction, so as not to agree with the true expansibility of the air, but with a smaller one. Laplace shows in the 4th volume of his *Mécanique Céleste*, p. 275, how to calculate the influence of vapour on refraction: supposing the constant quantity of refraction for 0.76 metre height of the barometer, and the

the temperature of freezing water to be $=60''\cdot303$, it is at the temperature of x degrees of the centesimal scale.

1. For perfectly dry air,

$$= \frac{60''\cdot303}{1+x\cdot0\cdot00375}.$$

2. For air saturated with vapour,

$$= \frac{60''\cdot224+z\cdot11''\cdot629}{1+x\cdot0\cdot00375}.$$

where according to Laplace log. Br. $z = -0\cdot0154547(100-x) - 0\cdot0000625826(100-x)^2$.

These two hypotheses give therefore for temperatures which usually take place at Königsberg, the value of the constant quantity

x .	Hyp. I.	Hyp. II.
-10°	$62''\cdot653$	$62''\cdot624$
0	$60\cdot303$	$60\cdot303$
$+10$	$58\cdot123$	$58\cdot189$
$+20$	$56\cdot096$	$56\cdot271$
$+30$	$54\cdot205$	$54\cdot563$

from which it is evident that refraction undergoes less change by the second than by the first hypothesis: the numbers for the former might be nearly represented by the formula

$$\frac{60''\cdot330}{1+x\cdot0\cdot003566}.$$

In order to preserve the common form of computation, the tables ought, therefore, to be founded on this formula, if that hypothesis were the correct one. Without measuring, therefore, the actually existing quantity of vapour which is not yet introduced in observatories, a nearer approximation to truth may be obtained by adopting for the change a formula in which the constant number is between $0\cdot003566$ and $0\cdot00375$, than by using the latter number: the formula for the change which ought to be used, depends on the mean ratio of the vapour contained in the atmosphere, to that which is required for saturation; and as there are no direct satisfactory observations on this subject, it may most safely be derived from astronomical observations.

If we represent the mean refraction as contained in the table of the *Fundamenta Astronomiæ* by g , the state of the barometer and the interior and exterior thermometer by b , τ' , τ (Paris lines, centesimal degrees, Fahrenheit's degrees), the refraction by which the observations have been reduced, is calculated by the formula

$$g' = g \left\{ \frac{b}{333\cdot28} \cdot \frac{1+10\cdot0\cdot00018484}{1+\tau' \cdot 0\cdot00018484} \right\} A \left\{ \frac{1-1^{\circ} 25\cdot0\cdot0020779}{1+(\tau-50)0\cdot0020779} \right\}^{\lambda}.$$

If,

If, instead of 0.0020779, we put 0.0020779 (1 + *i*) the calculated refraction is thereby changed by

$$\frac{-d\lambda (\tau - 48.75) 0.0020779 \cdot i}{[1 + (\tau - 50) 0.0020779] [1 - 1^\circ 25' 0.0020779]} = -mi,$$

and the polar distance of a star calculated from the observations suffers the change

- (*m* + *m'*) *i* for the upper passage south of zenith
- + (*m* - *m'*) *i* north of zenith
- (*m* - *m'*) *i* lower

where *m'* is the same for the pole as *m* for the star.

In order to determine *i* by observation, I have calculated by this formula all stars observed up to the end of the year 1821, the zenith distance of which exceeds 60°; I have taken the mean of all observations made in every position of the instrument, and compared the single ones with this mean, and thence, agreeably to the method of least squares, I have formed the following 56 equations of condition.

	No.	0=
α Aquilæ	97	+ 5.0 + 1289.0 <i>i</i>
α Ursæ Majoris	22	+ 8.7 + 119.3 <i>i</i>
α Hydræ	47	+ 145.8 + 1657.6 <i>i</i>
β Orionis	36	+ 149.0 + 1394.6 <i>i</i>
η Draconis	17	+ 39.6 + 236.2 <i>i</i>
α Cephei	23	+ 19.6 + 192.0 <i>i</i>
66 Draconis	19	- 18.7 + 153.4 <i>i</i>
η Cephei	20	+ 31.2 + 285.6 <i>i</i>
α Virginis	65	+ 106.7 + 2613.5 <i>i</i>
10 Cephei	19	- 15.7 + 132.8 <i>i</i>
XX. 222	16	- 6.1 + 157.6 <i>i</i>
\circ Draconis	20	+ 48.6 + 204.9 <i>i</i>
θ ———	18	+ 25.5 + 298.8 <i>i</i>
2 Cephei Hev.	18	- 41.1 + 195.6 <i>i</i>
48 Draconis	20	+ 4.1 + 262.2 <i>i</i>
δ Cephei	19	- 1.6 + 264.3 <i>i</i>
ζ ———	23	+ 30.1 + 285.1 <i>i</i>
53 Draconis	20	+ 25.9 + 261.2 <i>i</i>
ϵ Cephei	20	+ 4.1 + 195.6 <i>i</i>
33 Cygni	18	- 8.3 + 294.2 <i>i</i>
α Cassiopeiæ	29	+ 59.0 + 642.9 <i>i</i>
49 Draconis	20	+ 40.4 + 306.3 <i>i</i>
1 α Libræ	25	+ 6.8 + 198.2 <i>i</i>
2 α ———	26	+ 89.0 + 892.4 <i>i</i>

	No.	0=
γ Ursæ Maj.	26	+ 71 ^{''} ·3 + 748·7 <i>i</i>
α Canis Maj.	51	+ 349·8 + 1906·8 <i>i</i>
XX. 391	17	+ 29·3 + 240·4 <i>i</i>
51 Draconis	20	+ 53·9 + 413·4 <i>i</i>
\times Cygni	20	+ 25·3 + 411·2 <i>i</i>
XXI. 32	15	- 10·8 + 277·3 <i>i</i>
20 Cygni	18	+ 14·3 + 392·5 <i>i</i>
β Draconis	21	+ 252·7 + 1729·8 <i>i</i>
γ ———	22	+ 332·6 + 1939·3 <i>i</i>
<i>i</i> Cygni	19	+ 42·7 + 814·4 <i>i</i>
3 Lacertæ	18	+ 35·7 + 343·5 <i>i</i>
1 ω Cygni	17	- 1·4 + 353·1 <i>i</i>
η Ursæ Maj.	21	+ 93·7 + 631·0 <i>i</i>
c Cygni præc.	10	+ 1·3 + 347·6 <i>i</i>
——— seq.	10	+ 46·6 + 511·0 <i>i</i>
θ Cygni	20	+ 100·3 + 969·8 <i>i</i>
α Persei	22	+ 40·2 + 1027·9 <i>i</i>
1 ω Cygni	17	+ 2·9 + 743·9 <i>i</i>
α Aurigæ	34	+ 20·4 + 5506·6 <i>i</i>
α Scorpii	45	+ 107·3 + 3793·1 <i>i</i>
α Cygni	30	+ 482·8 + 6104·1 <i>i</i>
ε Aurigæ	20	- 13·7 + 447·7 <i>i</i>
γ Andromedæ	18	+ 172·3 + 2338·1 <i>i</i>
η Aurigæ	19	+ 65·9 + 939·6 <i>i</i>
β Persei	20	+ 222·9 + 1961·7 <i>i</i>
α Piscis austr.	36	+ 1325·5 + 30031·0 <i>i</i>
γ Cygni	15	+ 347·2 + 6582·3 <i>i</i>
ε Persei	15	+ 25·6 + 647·5 <i>i</i>
η Herculis	12	+ 200·9 + 6953·4 <i>i</i>
γ Bootis	7	- 233·8 + 2713·4 <i>i</i>
σ Cygni	11	+ 335·7 + 7233·3 <i>i</i>
α Lyræ	15	- 50·2 + 19472·1 <i>i</i>

I have taken up, in these tables, even those stars by which *i* cannot be advantageously determined: when applying the method of least squares, this may be done without danger, and the very excellence of this method consists in the possibility of profiting by even the smallest addition towards obtaining an accurate result: but only where it is possible* correctly

* Examples might be given where this method has been erroneously applied by neglecting circumstances, which would considerably have increased the probable errors; all objections which have been made to this method, do not apply to the method itself, but to the difficulty of correctly determining the probable error.

to appreciate the value of every addition, is it possible to derive a real advantage from this circumstance. Each of these equations gives i as accurately as the mean of so many observations, as there are unities in the coefficient of i : but these observations have very different probable errors; they are the greater, the nearer the horizon the observations have been made, partly on account of the dispersion of light, which increases in proportion of the refraction, partly on account of the tremor of the stars increasing near the vicinity of the horizon, and lastly, on account of the irregularities of the refraction itself, from causes which cannot be taken into the account.

In order to deduce these probable errors from the observations, i must be known; they can, therefore, only be obtained by repeated calculations.

Calling the sum of the squares of the differences between the mean of n observations and every single one, s ; and the probable error of a single observation ϵ ; we have

$$(n-1)\epsilon^2 = (0.6745)^2 s$$

and therefore, for each star, for which an arithmetical mean from n eastern, and another from n' western observations, has been derived

$$(n+n'-2)\epsilon^2 = (0.6745)^2 (s+s').$$

By this formula the following probable errors have been determined.

Z. D.				ϵ .
0	10 stars	293	observations	0.7126
46.13	4 ———	278	—————	0.7613
63.38	9 ———	265	—————	0.794
67.19	9 ———	174	—————	0.892
70.0	7 ———	195	—————	0.976
73.0	10 ———	187	—————	0.990
75.36	6 ———	100	—————	0.907
80.11	3 ———	109	—————	1.190
81.38	1 star	20	—————	1.155
83.41	1 ———	18	—————	1.693
84.9	1 ———	19	—————	1.127
84.52	1 ———	20	—————	2.155
85.8	1 ———	36	—————	1.850
85.26	1 ———	15	—————	2.53
85.38	1 ———	15	—————	1.87
85.50	1 ———	12	—————	2.41
85.59	1 ———	6	—————	2.84
86.25	1 ———	11	—————	3.55
87.27	1 ———	15	—————	3.79

The probable error on which the final determination of i is founded, I have determined by drawing with the greatest possible approximation a continuous curve through all points laid down from the values contained in the foregoing table: by multiplying each of the 56 equations of condition by $\left(\frac{0.7126}{\epsilon}\right)^2$, each has obtained that weight which it would have, if the observations had the accuracy of zenith observations. In this manner the following table was obtained.

	Z. D.	ϵ .	=0
α Aquilæ	46 18	0.76	+ 4.4 + 1133.3 i
α Ursæ Maj.	62 32	0.79	+ 7.1 + 97.1 i
α Hydræ	62 34	0.79	+ 118.7 + 1348.8 i
β Orionis	63 6	0.79	+ 121.2 + 1134.7 i
η Draconis	63 20	0.79	+ 32.4 + 192.2 i
α Cephei	63 26	0.79	+ 16.0 + 156.2 i
66 Draconis	63 47	0.80	- 14.9 + 121.7 i
η Cephei	64 7	0.80	+ 24.7 + 226.7 i
α Virginis	64 54	0.80	+ 84.5 + 2073.6 i
10 Cephei	64 57	0.80	- 12.5 + 105.3 i
XX. 222	65 26	0.80	- 4.9 + 125.1 i
\circ Draconis	66 5	0.81	+ 37.5 + 157.2 i
θ —	66 12	0.81	+ 19.7 + 230.7 i
2 CepheiHav.	66 54	0.83	- 30.4 + 144.5 i
48 Draconis	67 40	0.85	+ 2.9 + 184.3 i
δ Cephei	67 45	0.85	- 1.1 + 185.8 i
ζ Cephei	67 56	0.86	+ 20.6 + 333.1 i
53 Draconis	68 44	0.86	+ 17.8 + 179.4 i
ϵ Cephei	69 6	0.86	+ 2.8 + 134.3 i
33 Cygni	69 13	0.86	- 5.7 + 202.1 i
α Cassiopeiæ	69 41	0.86	+ 40.5 + 441.4 i
49 Draconis	69 50	0.86	+ 27.7 + 210.4 i
1 α Libræ	69 54	0.86	+ 4.7 + 136.1 i
2 α Libræ	69 58	0.86	+ 61.0 + 612.8 i
γ Ursæ Maj.	70 32	0.87	+ 47.8 + 502.4 i
α Canis Maj.	71 8	0.88	+ 229.5 + 1251.0 i
XX. 391	71 24	0.89	+ 18.7 + 154.1 i
51 Draconis	72 8	0.90	+ 33.8 + 259.2 i
\times Cygni	72 12	0.90	+ 15.9 + 257.8 i
XXI. 32	72 24	0.90	- 6.7 + 173.8 i
20 Cygni	72 42	0.91	+ 8.7 + 240.8 i
β Draconis	72 48	0.91	+ 155.0 + 1061.2 i
γ —	73 45	0.93	+ 195.3 + 1138.6 i

	Z. D.	ϵ .	=0
ι Cygni	73 53	0 ^o .94	+ 24 ^o .5 + 468.2 i
3 Lacertæ	73 54	0 ^o .94	+ 20.5 + 197.3 i
1 ω Cygni	74 52	0 ^o .96	- 0.8 + 194.3 i
η Ursæ Maj.	75 0	0 ^o .97	+ 50.6 + 340.5 i
c Cygni præc.	75 7	0 ^o .97	+ 0.7 + 187.6 i
— seq.	75 7	0 ^o .97	+ 25.1 + 275.9 i
θ Cygni	75 25	0 ^o .97	+ 54.1 + 523.4 i
α Persei	76 0	1 ^o .00	+ 20.4 + 522.0 i
1 ω Cygni	76 26	1 ^o .01	+ 1.4 + 370.3 i
α Aurigæ	79 24	1 ^o .13	+ 8.1 + 2190.0 i
α Scorpii	80 36	1 ^o .20	+ 37.9 + 1337.6 i
α Cygni	80 39	1 ^o .20	+ 170.3 + 2152.6 i
ϵ Aurigæ	81 38	1 ^o .27	- 4.3 + 141.0 i
γ Andromedæ	83 41	1 ^o .53	+ 37.4 + 507.2 i
η Aurigæ	84 9	1 ^o .64	+ 12.5 + 177.4 i
β Persei	84 52	1 ^o .80	+ 34.9 + 307.5 i
α Pisc. austr.	85 8	1 ^o .90	+ 186.4 + 4224.5 i
γ Cygni	85 26	2 ^o .08	+ 40.7 + 772.6 i
ϵ Persei	85 38	2 ^o .20	+ 2.7 + 67.9 i
η Herculis	85 50	2 ^o .32	+ 19.0 + 656.0 i
γ Bootis	85 59	2 ^o .50	- 19.0 + 220.1 i
σ Cygni	86 25	3 ^o .60	+ 13.1 + 283.4 i
α Lyræ	86 27	3 ^o .70	- 1.8 + 722.3 i

These equations indicate very clearly a negative value of i : considering the small weight of most of them, their agreement is satisfactory, which, if the exponent λ had been neglected, would by no means have been the case. The sum of the equation is $s = 0 = 2007^o.0 + 31745.3 i$; from which follows,

$$i = - 0^o.063222; \text{ probable error} = \pm 0^o.003981.$$

[To be continued.]

XVII. *An Account of the Mesembryanthema Ringentia.* By
A. H. HAWORTH, Esq. F.L.S. &c.

To the Editors of the *Philosophical Magazine and Journal.*

Gentlemen,

HEREUNDER you will receive an improved account of the sessile-flowered *Mesembryanthema Ringentia*, which form, perhaps, one of the most interesting divisions of the large genus to which they belong.

Some

Some of these extraordinary plants are now becoming frequent in our collections, and have ever been fancifully likened by gardeners to the chops of animals; and thence called Cat-chop, Mouse-chop, Tiger-chop, &c. *; and this from the fantastical idea of each young pair of leaves on the plants bearing some resemblance to the gaping mouths of those well-known quadrupeds; the ciliating teeth on the margins of the leaves not unaptly representing those of the animals.

The addition of a new species to this singular group has induced me to reconsider the whole, and to forward to you the present communication respecting it for insertion, if you judge it proper, in your Magazine.

This new species, from its long teeth, and following up the allusion of a gaping mouth, I have called *lupinum* (the Wolf's-chop), the substantive *rictum* being understood, as usual, to accompany the adjectives constituting the specific names throughout the group.

This fine and interesting plant was obligingly communicated to me by my good friend W. T. Aiton, Esq. from the Royal Gardens of Kew, in the year 1823, having been there raised the year before, from Cape seeds, along with a profusion of other succulent and still more interesting plants; which, through Mr. Aiton's successful exertions, have delighted us with more of the flowery bloom of Africa than we have ever elsewhere seen.

I remain, gentlemen,

Your most obedient servant,

Chelsea, Aug. 1824.

A. H. HAWORTH.

MESEMBRYANTHEMUM *Linn.* Sectio RINGENTIA *Nobis*.

Sectionis Characteres.

Perennia, acaulia, subacauliave: foliis carnosioribus amplexicaulibus semiteretibus, supernè pedetentim dilatantibus, apicem versus triquetro-carinatis, ciliatim ad oras dentatis: floribus magnis pomeridianis sessilibus luteis.

Foliorum juniora paria animalium rictum repræsentant lusoriè.

* *Majora*: acaulia: foliis lævibus magnis crassis dentibus marginalibus albâ setulâ finientibus, apice cartilagine albo-carinatis.

Specierum Characteres.

tigrinum. M. (The Tiger-chop) virescens: foliis cordato-
1. ovatis albo crebrè marmoratis, altissimè ciliatis, supra

* The Dog-chop (*M. caninum*) and Fox-chop (*M. vulpinum*), being scapigerous plants, are removed to the section *Scapigera*.

planis.

planis.—*Mesemb. tigrinum*. *Nob. in Synops. Pl. Succ.* 216, &c. *Bot. Reg.* 260.

felinum. *M.* (The Cat-chop) foliis glaucescentibus parçè
2. altèque ciliato-dentatis, ad lucem creberrimè albo-punctatis.—*Mesemb. felinum*. *Nob. in Synops. Pl. Succ.* 216, &c.—*M. ringens felinum*. *Linn. Sp. Pl.* 698.—*M. rictum felinum repræsentans*. *Dill. Elth. f.* 230.

lupinum. *M.* (The Wolf's-chop) foliis glaucescentibus, ciliis
3. marginalibus numerosis altissimis.

Obs. Nova species à Capite Bonæ Spei. Priori simillimum discrepantibus foliis longioribus angustioribus, dentibus duplò numerosioribus, longioreque setulâ finientibus.

β, foliis viridibus.

** *Minora*: subacaulia: foliis creberrimè tuberculatim punctatis asperiusculis, quam speciebus tribus prioribus 4-plo plusve minoribus; dentibus marginalibus brevibus fere absque setulâ finiente.

Foliorum carina apicalis sine cartilagine alba.

mustelinum. *M.* (The Weasel-chop) foliis pellucenter mag-
4. nipunctatis glaucis, basi internè pustulato-gibbosis.—*M. mustelinum*. *Nob. in Suppl. Pl. Succ.* 86, &c.—*Vespertini flores* pungenter suavissimè spirant.

murinum. *M.* (The Mouse-chop) foliis glaucis turberculato-
5. punctatis, marginibus carinâque apicali ciliato-denticulatis.—*M. murinum*. *Nob. in Synops. Pl. Succ.* 217, &c.

Obs. Foliorum dentes longiores numerosiores angustioresque quam in præcedente.

XVIII. *A Sketch of the Progress of Science respecting Igneous Meteors and Meteorites during the Year 1823; including an Account of the principal Phænomena of that Nature observed during the same Period: with Inquiries suggested by those Subjects.* By E. W. BRAYLEY, junior, A.L.S., and Member of the Meteorological Society*.

THE arrangement and publication of an annual historical detail of the progress of meteorological science, in its several branches, and of the atmospheric changes and phænomena observed in the various regions of the globe during each successive year, appears to be an object well deserving the attention of the Meteorological Society. A summary of

* Read before the Meteorological Society, May 12, 1824; and published by permission of the Council: with additions by the author.

this kind, I conceive, would be useful in various ways: the historical part would refer those who might be examining or making new researches upon particular subjects of meteorology, to the sources of the latest information respecting them; and would point out, to a considerable extent, those divisions of the science which stand most in need of further investigation: whilst the comprehensive detail and comparison of the atmospheric changes and phænomena observed during the past year, would indicate those subjects of observation, which, from time to time, might appear more particularly to require the attention of those who register the changes of the weather.

Various meteorological observers, both in this country and on the continent, are in the habit of drawing up and publishing annual statements of this nature, as far as their own observations are concerned: but the only review of meteorological observations which is in any degree of a general kind, and the only one also, I believe, that emanates from any scientific institution, is the *Résumé des Observations météorologiques faites à l'Observatoire Royal de Paris*, arranged by M. Arago, and published, from year to year, in the *Annales de Chimie*. This summary, besides the observations forming its basis, the excellence of which is well known to those who have had occasion to examine them, usually contains a selection of the more remarkable phænomena which have taken place during the year; as well as a calendar of earthquakes and of volcanic eruptions; and a catalogue of the spots on the sun observed during that period, in order to furnish the means for a rigorous examination of the opinion that they have a sensible influence upon the temperature of the earth. The propriety of including the phænomena of earthquakes and volcanoes in such a review cannot be too strongly recommended; not so much, in the present case, with a view to the discovery of their causes, as to the investigation of their influence upon and connexion with various phænomena strictly within the province of the meteorologist; and which, there seems reason to believe, takes place to a greater extent than is usually imagined. There are subjects, likewise, of a different kind, to which it would be desirable to attend, in the arrangement of this work; such as the times of the migration and return of certain birds, and in the higher latitudes of those of some other animals: the investigation of these subjects, in conjunction with observations on the weather, and with attention, in the case of birds, to the true cause of migration, as developed by the late Dr. Jenner in his admirable paper on the subject some time since read before the Royal Society, would perhaps enable us, in process of time, to draw some just conclusions respecting the advance of the seasons,

&c. in countries where meteorological observations are not commonly pursued.

So extensive an arrangement of new facts and observations as that which I have ventured to suggest, would obviously be a work of considerable labour, and would require the conjoint attention of inquirers into the various branches of meteorology: and as the expediency of its preparation, amongst other matters of a collateral and subordinate nature, may hereafter become a subject of consideration with the Council, when the primary object of our association, that of "establishing a Meteorological Observatory, and instituting operations to be conducted with undeniable accuracy, and with instruments of standard excellence," shall have been carried into effect; I shall here terminate these remarks; and proceed to lay before you a sketch of the progress which has been made, during the past year, in a branch of the science to which I have lately devoted some attention, and a work on which I am preparing for the press, viz. that which relates to the phænomena of igneous meteors and their products.

I shall first pass in review, in a succinct manner, the principal new facts, and results of induction from them, respecting igneous meteors and meteorites, which have been made known to the cultivators of science during the year 1823; and then proceed to describe the chief phænomena of that nature observed during the same period. Some inquiries of an interesting character will suggest themselves as we proceed: and I shall have the pleasure of communicating various facts of foreign observation which have not yet appeared in any of our philosophical journals; together with a few results of my own inquiries.

§ 1. *Progress of Science respecting Igneous Meteors during the Year 1823.*

Accounts of the fire-balls which were seen in the States of Ohio and Pennsylvania in 1819, have been published by Professor Silliman; together with a valuable collection of observations on the splendid meteor of that description which was beheld over a great extent of country in the United States, and also in Canada, on the 9th of March 1822.

The first, which appeared in the evening of the 24th of July 1819, is described by Dr. Henry Manning of Youngstown, Ohio, as a large meteor pursuing its course through the atmosphere in a direction nearly north. He had a clear view of it for a few seconds before its explosion, and at that time; and about three minutes, by estimation, after the visible explosion, he heard the report, which resembled that of a heavy

cannon fired in a still evening, at the distance of three or four miles. A gentleman who was in the township of Gustavus, precisely twenty miles north from Dr. Manning's situation, saw the light, and thought the sound succeeded in something more than a minute. The distance from Youngstown to the south shore of Lake Erie, Dr. M. states, is rather more than forty miles, "and much of the country south of the lake is still a wilderness, making it uncertain whether any discoveries will be made if meteoric stones have fallen*."

The only data for computation afforded by this account are the times which elapsed between the explosion and the report at the two stations; and from these we may infer that this meteor was much lower at the period of its explosion than many others have been; its elevation, probably, not exceeding a mile. The proximity of the lake renders it probable that the results of the explosion, if massive, were lost in its waters.

The meteor seen in Chester county, Pennsylvania, on the 21st of November 1819, is described by the Editor of the *American Watchman*; and by Mr. S. Turney, of some place in the above county about 60 miles nearly south of Easton on the Delaware; from a comparison of whose accounts its characters and phænomena appear to have been as follows: It was a "fire-ball," appearing to be a compact mass of fire, in which is said to have been combined all the redness of Mars and the softer light of the moon; the entire phænomenon being sublime beyond description. At what hour it appeared is not stated, but doubtless in the evening, for the first-mentioned observer says, "While standing in the open air, we were surprised by a sudden flood of light sufficient to enable us to read the smallest print:" Mr. Turney also states its light to have been very vivid. The former describes it as having been about half the size of the full moon, when first observed; and Mr. T. found that many competent persons declared that it was of about one third of the apparent magnitude of that luminary. A well defined conical tail extended from it, to the length of 4° or 5° ; but no sparks were observed. When first seen by the Editor (at Chester?), it was 50° or 60° above the horizon; and when first observed by Mr. Turney, at the altitude of about 45° in the north-east: at the former place it passed in an east-north-east direction, a little to the south of the zenith; and it was estimated to have been about two seconds in progression before it was observed, whence it is inferred that it first appeared at about 30° above the eastern

* American Journal of Science, vol. vi. p. 315.

horizon: it travelled, whilst within view here, about 120° in the heavens, and that in a period of not less than five, nor more than ten seconds; beginning to decline in brilliancy when at about 30° below the zenith, and in two seconds becoming invisible, at 30° above the western horizon; its tail, in the mean time, lengthening to 10° or 15° , forming a narrow red streak of evanescent fire. Mr. Turney states it to have passed through his hemisphere in a very few seconds; and near Easton, where a sound was heard in its direction. It suddenly disappeared from him at about the altitude of 40° , in the south or south-west. About three minutes after its disappearance, says the Editor of the *American Watchman*, a noise was heard resembling the discharge of cannon, or distant thunder, and in a westerly direction: after the lapse of two, three, or four minutes, Mr. Turney observes, two reports were heard, the sound continuing for many seconds.

By comparing the observations made by various persons in different situations, Mr. Turney estimated the height of this meteor to have been at least twenty miles: and taking its apparent diameter at one-third of the moon's, he computes its actual diameter at more than one hundred yards. The nature of the observations from which the height was determined is not stated; but such vague estimates of the apparent magnitude of a luminous body in rapid motion as those above given, are evidently insufficient for a near approximation to its actual size. The sound heard at Easton, Mr. T. thinks, could not have been the same with that heard at his station, "which came from a point not less than thirty miles to the south;" whence he infers, "that the body must have been ignited a second time." This supposition, however, appears to me to be unnecessary; for the sound heard in the direction of the meteor at Easton probably arose from the velocity of its passage through the atmosphere: thus, a whizzing sound like that of a bomb traversing the air, together with a crackling noise, was produced in its flight by the meteor which threw down a stone at Sales, near Villefranche, March 12, 1798; also by that observed at Geneva, May 15, 1811, which has been described by Professors Pictet and Prevost; as well as by several others.

Mr. Turney, in agreement with the view of the nature of these phænomena which has within these few years become very general amongst scientific men, and which, perhaps, is the most satisfactory hitherto proposed, terms the meteor just described a *terrestrial comet*; and suggests that it may be the same with that which passed over Connecticut and cast down a shower of stones in 1807, its course being nearly the same.

Upon this Professor Silliman remarks, "its size, as conjectured by Mr. Turney, is much less than the estimated size of that meteor*." As the examination of the conjecture would lead me into a question which I am not yet prepared to discuss, viz. whether, when a meteor of this description explodes, its entire nucleus falls to the earth in the form of meteorites, as commonly believed; or whether a portion only of its substance is separated and cast down, so that the main body of the meteor still proceeds on its course, as some writers have contended, and in which latter case the same meteor may be seen repeatedly; I must omit it for the present: some remarks however upon a subject which is involved in Professor Silliman's objection, will be found in a subsequent page of this section, where Professor Dean's estimate of the magnitude of the great fire-ball of 1822 is stated.

The collection of observations on the great meteor that passed over several of the northern Anglo-American States, on the 9th of March 1822, together with the calculations founded on some of them by Professor Dean, are among the most interesting of the kind; and may rank with the observations and deductions respecting the Fire-balls of 1719, 1758, 1771, and 1783, given, respectively, by Dr. Halley, Sir John Pringle, M. Le Roy, and Mr. Cavallo and others. In some respects, indeed, they are peculiarly instructive.

From a comparison of these observations, it appears that this meteor was seen over a tract of country including the space from Portland in the state of Maine, in long. $70^{\circ} 20'$ W. to Oxford, in Chenango county, New York, in about long. $75^{\circ} 45'$; and from some part of Rhode Island, lat. at most 42° N., to Quebec, lat. $46^{\circ} 50'$. The tract was no doubt considerably greater in extent, but the foregoing are the only definite limits for which data are afforded. The path of the meteor was from north-east to south-west; or more accurately, according to Prof. Dean, the direction of its motion was south 34° west: and according likewise to his computations, it must have traversed a space of about two hundred and fifty miles, between the zenith of Wilkesbarre in Pennsylvania, and that of Essex, a village on the western shore of Lake Champlain.

Mr. Doty, who observed this meteor from a point of the Mohawk turnpike road, near Canajoharie, in the state of New York, and who appears to have had it nearly in his zenith, estimated its diameter at from twenty to thirty feet. To other observers, according to their situation, and according, likewise, as I shall endeavour to show in the sequel, to the actual change of bulk and of figure in the meteor, it ap-

* American Journal, vi. p. 319.

peared of various sizes: some stating its apparent diameter at six feet; many comparing its size to that of the moon: whilst to others, who were still more distant from it, it had the appearance of a large shooting star.

It is described by every one as having been of extreme brilliancy; and that it must indeed have been intensely vivid, is evident from the circumstance, that the impression produced by it on the eye of one observer induced him to state, "*that it was more brilliant than the most vivid flashes of lightning, or even the meridian sun.*" And though the contrast of its splendour with the previous darkness of night doubtless had its share in producing such an impression, yet there are various instances on record of meteors displaying great brilliancy even when opposed to the meridian sun. The meteor observed at Cambridge in 1818 by the late Dr. Clarke, and that seen in Bretagne in 1684 by the Abbé de l'Anion, were of this description. The most intense light of the American meteor, as in other cases, appears to have been emitted at the time immediately prior to the visible effects of its explosion: thus at Quebec, from which place it must have been very distant, having been seen there and at Montreal nearly in the same direction, and where "the sky was clear, and the moon nearly at full, in an opposite direction,—the light of the meteor when it divided was so strong as entirely to destroy the shadows of the moon-light and throw them into a contrary direction." The visible explosion of this meteor is variously described by the different observers. Mr. Doty relates "that it soon began to extend itself to the north-east and south-west, increasing in extension, and decreasing in its flaming appearance, until nothing was to be seen but two detached parts of it rapidly moving in different directions towards the north-east and south-west." A writer in the *Sangersfield (Oneida) Intelligencer* states, "that it burst with a violence which seemed to throw all nature into convulsions. It discharged its massy balls of electric fire in every direction, when all disappeared before they reached the ground." Another observer compares these appearances to the coruscations of a rocket; and at Quebec "it divided into numberless pieces, having the appearance of the stars usually thrown from sky-rockets, but of a superior brilliancy and beauty, the whole disappearing before they reached the horizon." When first observed by Colonel Page, of Burlington in the state of Vermont, it appeared like a common shooting star, which, moving south-westerly, passing a little south-east of *Procyon*, when about one-third of the way from *Procyon* to *Sirius*, suddenly broke out in great splendour, *continued its course, flashing and sparkling,*

sparkling, east of *Sirius*, and disappeared, apparently by extinction. The report produced by the explosion is said by Mr. Doty to have resembled the noise of distant cannon: at Troy in the state of New York two distinct explosions were heard, with a very short interval of time; and the sound reached the ear of another observer at the same place in about seven minutes and a half after the disappearance of the meteor. At Herkimer, in the same state, an explosion was heard from the south, about four minutes after the meteor had passed, which resembled the discharge of four or five pieces of artillery. At Ballston Spa, two, and some say three, reports were heard on its disappearance.

The explosion, according to Mr. Doty, sensibly affected several houses, and was followed by a strong sulphurous smell that lasted fifteen or twenty minutes.

The luminous track left in the atmosphere by this meteor, is among the most curious phænomena it displayed, and shows, in a particular manner, its affinity with some other meteoric appearances. At Troy it left a luminous track in the heavens, which was not totally extinguished in several minutes after the meteor disappeared: the *Sangersfield Intelligencer* states that it left in its train an astonishing mass of livid fire, which remained after the explosion for the space of ten minutes, and then gradually disappeared like the rainbow: according to the *Bridgeport Courier*, after moving with great velocity from north-east to south-west, "it left a trail of immense size and peculiar brightness:" Captain Wardner of Windsor, in the state of Vermont, describes it as leaving in its passage a dusky reddish track, which continued, especially about the middle of its length, for two minutes. At Quebec the track assumed the form of an arched chain of fire, vividly delineated in the heavens, and concaving towards the earth; which disappeared in a minute or two.

The meteors with which these circumstances more particularly connect the present, are those which were seen, respectively, at Geneva and many other places, May 15, 1811; at Angers, Loudon, and Poitiers, producing a meteoric stone, June 3, 1822; and at Paris, Caen, and other places on the 6th of August in the same year. The first, as described by Professor Pictet, was a kind of serpent of fire, bent back at the west end, so as to approach the figure of the letter S; which became spread out in the lower part, and then successively assuming the shapes of a horse-shoe and a parabola, diminishing in brightness every instant, became reduced in seven or eight minutes to two bright points; and was then concealed by a cloud. The meteor of the 3d of June 1822, as seen from
Poitiers

Poitiers by M. Boisgiraud, had the appearance of a beautiful falling star, that left after it a luminous rectilinear train, containing a bright point; the inferior extremity of which took a spiral figure, its brilliancy gradually decreasing, and became divided into two branches: one of these gradually diminished to the point just mentioned; and this became slowly extinguished, in a quarter of an hour after the first appearance of the phenomenon. The third phenomenon of this nature I have alluded to was observed at Paris by MM. Gay-Lussac and Berthier: it was a large and beautiful luminous serpentine train of light, as thick as the wrist, occupying a space of about thirty degrees, and likewise containing a luminous point at the lower extremity; it continued full five minutes. At Caen this meteor appeared to descend vertically, giving out a light equal to that of brilliant lightning, throwing out sparks, and leaving a long, luminous, undulating tail filled with sparks.

[To be continued.]

XIX. *Analyses of a Series of Papers on the Structure, Distribution, and Functions of the Nerves; by CHARLES BELL, Esq.; which have appeared in some late Volumes of the Philosophical Transactions.*

[Continued from p. 50.]

FROM the analysis which we have given of Mr. Bell's first paper in the *Philosophical Transactions*, strong evidence is afforded of there being two distinct sets of nerves in the body, the one regulating the respiratory apparatus and all the muscles and parts which are brought into associate action with it; the other being muscular nerves ordering the voluntary motions of the frame, and endowing the surfaces of the body with common sensibility. This evidence was supplied from a detail of his experiments and observations on the nerves of the face; and as he confined himself as strictly as possible to these nerves in particular, the following experiments and observations on the nerves of the trunk are not a mere continuation of the same subject, but also a confirmation of his new views respecting the arrangement of the nerves in general. The attention of our readers must therefore be called to the nerves of the trunk, or to those which associate the muscles of the chest, in the actions of breathing, speaking and expression, as distinguished from those nerves which, though intimately blending themselves with them, are nevertheless destined for a different function altogether: and that our readers may bear with the detail into which it will be necessary to enter, they must

must receive the author's assurance, "that already practical benefits have resulted from the former paper; that the views presented there, as connected with general science, being carried into practice, have enabled the physician to make more accurate distinctions of disease, and the surgeon, in removing deformity, to avoid producing distortion."

Of the Motions of the Thorax, as affording a Key to the Intricacy of its Nerves. (*Phil. Trans.* 1822).

By enumerating the uses of the compages of bones and muscles which constitute the walls of the thorax, we are made sensible of the extent of the respiratory actions, and that they in fact extend over the whole face and neck and trunk; and how the mechanism of the thorax, or rather the respiratory apparatus generally, affects the arrangement of the whole nervous system. The uses of the thorax, independently of affording support and protection to the heart and lungs, and the viscera of the higher region of the abdomen, being, 1st, to alternately oppose, and yield to the weight of the atmosphere, thus producing respiration: 2dly, to manifest an occasional increase and agitation commensurate to the excited state of the animal frame when additional muscles are brought into action: 3dly, to produce natural voice and articulate language: 4thly, to exhibit the emotions and passions of the mind: 5thly, to join with the muscles which move the cartilages of the nose in the act of smelling, which is as necessary to the sense of smelling as the act of expiration is to the production of speech: 6thly, to give power to the arms in voluntary action; seeing that this is in a great measure dependent upon the expansion of the thorax, inspiration being always combined with sudden and powerful exertion.

Origins of the respiratory Nerves.

In all animals which have ribs rising and falling by respiratory muscles, we find a *medulla spinalis* and the distinction of *cerebrum* and *cerebellum*: and experiment and observation prove that the extended act of respiration is controlled by a power seated in the lateral portions of the *medulla oblongata*, and continued from thence through certain respiratory nerves passing out from the neck, and through the intercostal nerves also lower down in the spine.

But the associated actions of respiration depend upon certain nerves which arise very nearly together, though in a line or series, from a distinct column of the spinal marrow: this column or track of medullary matter is a continuation of the *corpus retiforme*, which is situated just posterior to the *corpus olivare*, and may be traced down the spinal marrow betwixt the

the *sulci*, that give rise to the anterior and posterior roots of the spinal nerves. From this narrow medullary column arise in succession from above downwards, the *portio dura* of the 7th nerve; the *glosso-pharyngeus* nerve; the nerve of the *par vagum*; the *nervus ad par vagum accessorius*; the *phrenic* and the *external* respiratory nerves: these latter nerves, though coming out with the cervical, do in all probability take their origin from the same portion of the *medulla spinalis* with the accessory nerve. With regard to the intercostal nerves, or those which actuate the intercostal muscles, they by their relations with the *medulla oblongata* are equal to the performance of respiration as it regards the office of the lungs; but they are not adequate to those additional functions which are in a manner imposed upon the respiratory apparatus, when they are brought to combine in other offices.

Of the Muscles of the Trunk, which are brought in aid of the common respiratory Muscles.

It is not difficult to discover what muscles are best calculated by their situation and direction to assist in the motions of the chest, when there is increased or excited action; nor less so to assign a use to the nerves which supply these muscles exclusively. These nerves are not only remarkable on this account, but also from their having the same origin.

In this inquiry it is necessary to observe, that the life of animals is protected by a particular sense which gives rise to an instinctive motion of drawing the breath, by which the chest is suddenly and powerfully expanded, on exertion or alarm. The start on sudden alarm is accompanied with a rapid expansion and rising of the chest; and the voice, at such a moment, is produced by suddenly inhaling, and not by expiration; and this expansion of the chest combines with the preparation for flight or defence, since the extension of the muscles lying on the breast and back is produced by this motion, and since they are thereby rendered more powerful in their influence upon the arms or anterior extremities.

It cannot escape observation that oppression and difficulty of breathing is exhibited in gasping and forcible inspiration, in drawing the breath, not in throwing it out: accordingly we find that the muscles above alluded to are powerfully influenced in deep inspiration, whether the action be voluntary as in speech, or involuntary as in the last efforts of life, when sense is lost; they are the mastoid muscle, the *trapezius*, the *serratus magnus*, and the *diaphragm*.

1. *Sterno-cleido-mastoidæus*. This muscle by being attached

to the sternum or breast-bone, raises or heaves the chest; and the operation of this muscle is very evident in all excited states of respiration, in speaking, and still more in singing, coughing, and sneezing. But there is something necessary to the full effect of this muscle on the chest; for otherwise it will be a muscle of the head, and not of the chest.

2. The *trapezius* must fix the head or pull it backwards before the *mastoideus* can act as a respiratory muscle; and how they are combined we shall presently see.

The position of the head of the asthmatic during the fit, as well as the posture of the wounded or the dying, proves the influence of the upper part of the *trapezius* in excited respiration.

3. The *serratus magnus anticus*, being extended over the whole side of the chest, and attached in all the extent from the 2d to the 8th rib, is very powerful in raising the ribs; but it cannot exert this power independently of the *trapezius*; since, without its combination, its force would be exerted in moving the scapula, and not the ribs: unless the scapula be fixed, or pulled back by the *trapezius*, the *serratus* is not a muscle of respiration.

In this manner do these three powerful muscles hang together in their action, combining with the diaphragm to enlarge the cavity of the chest in all its diameters; and to these muscles are distributed in a peculiar manner the nerves which may thence appropriately be termed the respiratory nerves of the chest.

The Anatomy of the respiratory Nerves of the Trunk.

1. The *phrenic* takes its origin or proceeds from the fourth cervical nerve, a more slender branch joining it from the third cervical; it also has connexions with the *nervus vagus*, the *lingualis medius*, and at the same time gives off a branch to the *larynx*. Its trunk descends into the cavity of the thorax, giving off no branches till it diverges and disperses itself in the substance of that muscle: the irritation of this nerve convulses the diaphragm, and cutting it across paralyzes it; the connexions moreover which we have enumerated would mark its relations.

2. The *external respiratory nerve of the thorax* is a counterpart of the former, or internal respiratory; it proceeds from the 4th and 5th cervical, like the phrenic, and is often connected with it. This nerve descends as a distinct flat trunk upon the outside of the chest to be distributed exclusively to the *serratus magnus anticus*. This muscle has nerves coming to it from the spinal marrow besides, because it has to combine

bine in the motions of the frame in locomotion; the former nerve, however, by its influence renders it a muscle subservient to the production of full inspiration.

3. The *spinal accessory nerve* is particularly an object in this paper. It is called the superior respiratory nerve of the trunk, and its anatomy demands attention because it leads in a most conclusive manner to a knowledge of its functions.

It arises from the cervical portion of the spinal marrow; but, different from the two former, which collect their branches to go out by the side of the vertebræ, it shoots upwards within the *theca* of the spinal marrow, enters the skull through the *foramen magnum*, and joins the *par vagum*; whence it bears the name of *accessory*: the roots of this nerve are seen issuing from the spinal *medulla* as low down as the 4th cervical nerve, not from its anterior or posterior column, but from that before mentioned which lies betwixt the posterior roots of the cervical nerves and the *ligamentum denticulatum*. Its origins are therefore situated in one line, which is in the direction of the roots of the eighth pair and of the *portio dura* or respiratory nerve of the face. It is attached in its ascent to the posterior root of the first cervical nerve.

When it has entered the skull, it is associated with the nerves constituting the *par vagum*, being contained in the same sheath with them; they all go out through the *foramen lacerum* by the side of the jugular vein. In this course the accessory nerve divides into two branches, one of which joins filaments of the *par vagum*, and these again send nerves to the *glossopharyngeal nerve*, and sometimes a branch is seen going to the *lingualis medius*. The more exterior branch descends behind the jugular vein, and comes forward and perforates the mastoid muscle, to which it furnishes filaments invariably.

On escaping from the mastoid muscle, it communicates with a branch of the 3d cervical and receives one from the 2d: it now descends upon the neck and disperses itself to the *trapezius*, by many subdivisions, one of which is increased by a long descending branch of the 2d cervical nerve; this branch so enlarged passes under the *trapezius*, attaches itself exclusively to the *trapezius*, and is again joined by branches from the spinal nerves behind the clavicle, where it forms a sort of imperfect plexus, and is finally dispersed among its fibres. Thus do we see that this nerve may with strict propriety be termed the *superior respiratory nerve of the trunk*; for it lavishes all its branches on the *mastoid* and *trapezius* muscles solely, after taking a circuitous course to form a junction with the *par vagum* and with the nerves of the *tongue* and *pharynx*;

and sends branches to the *larynx* in company with the branches of the *par vagum*.

The author next proceeds to take a comparative view of these nerves, and shows that they accommodate themselves to the form and play of the organs of respiration, under all their modifications, as presented by various animals, birds, and fishes; whence he very justly forms a conclusion that they are all respiratory nerves, even though they may be found to vary in their course of distribution. A remarkable example of which is afforded by the nerves of the neck in birds. In them the bill precludes the necessity of the *portio dura* going forward to the nostrils and lips; the nerve turns backwards, and is given to the neck and throat; and it is particularly worthy of remark, that the action of raising the feathers of the neck, as when the game cock is facing his opponent, is taken away by the division of this nerve.

The Functions of these Nerves further illustrated.

The lower extremity of the mastoid muscle being fixed when we move the head, and the reverse being the case when we employ it in inspiration, render it evident to every one that it has two motions. The same is confirmed by attending to the actions of snuffing and smelling, as, by placing the fingers on the portions of the mastoid muscles which are attached to the sternum, we shall find every little motion of the nostrils accompanied with corresponding actions of the sternal portions of the muscles in the neck.

A man having complete hemiplegia, the side of his face relaxed, the arm hanging down powerless, and the leg dragged in walking, we were curious to know if the influence (or rather the want of it) pervaded all the nerves of the side, or only the regular or voluntary nerves. Some trouble was taken to make him heave up the shoulder of the debilitated side; but to no purpose. He could only do it by bending the spine to the other side, and as it were weighing up the paralytic shoulder. But on setting him fairly in front, and asking him to make a full inspiration, both shoulders were elevated at the same time that both the nostrils were in motion. The respiratory nerve of the face, and the superior respiratory nerve, were entire in their office; and, although the regular system of nerves refused acting, the *sterno-mastoideus* and the *trapezius* partook of their share in the act of respiration.

The mastoid muscle being supplied with both sets of nerves, that is to say, voluntary and respiratory, the former would appear to join in producing the voluntary motion of the head,
and

and the latter in raising the chest; and this is confirmed by an experiment consisting in the division of the superior respiratory nerves of the ass during the time of excited respiration; the consequence of which is the cessation of the increased respiratory action, and relaxation of the *sterno-maxillaris* and *sterno-vertebralis* muscles, which answer to the *mastoid* in man; and this relaxation continues until the animal brings them into action as voluntary muscles.

An ass being thrown, its phrenic nerves were divided, on which a remarkable heaving of the chest took place. It rose higher, and the margins of the chest were more expanded at each respiration. There was no particular excitement of the muscles of the neck, shoulder, or throat, at this time; so that to excite the actions of these muscles, it was necessary to compress the nostrils. When they began to act with more violence, keeping time with the actions of the other muscles of respiration, the superior respiratory nerve was divided; immediately the action ceased in the muscles attached to the sternum of the side where the nerve was divided, while the corresponding muscles of the other side continued their actions.

It is well known that on the division of the spinal marrow between the cervical and dorsal vertebræ, the respiration is continued by the diaphragm. The phrenic nerves being first divided, and then the spinal marrow cut across at the bottom of the cervical vertebræ, respiration was stopped in the chest; but there continued a catching and strong action at regular intervals in the muscles of the nostrils, face, and side of the neck. These actions ceased also after a time, but were renewed upon reanimating the animal by artificial breathing, which was done several times, the animal however remaining insensible.

This class of nerves indicated, by stimulating them after death, a power of retaining their life the longest.

To avoid the unnecessary repetition of experiments, the author states the facts which have been ascertained by the exertions of others respecting the remaining nerves of this class. Thus the voice is destroyed by dividing the recurrent branch of the *par vagum*. The consent of motion between the muscles of the glottis and those of the chest, is lost by the division of the laryngeal branch of the *par vagum*. An injury of the *par vagum* produces difficulty of breathing.

Although the regular succession of spinal nerves be equal to the raising and depressing the thorax, and essential to respiration, still they are not competent to the performance of the motions of the glottis, pharynx, lips, and nostrils; which
several

several parts are necessarily influenced in excited respiration, as well as in the acts of smelling, coughing, sneezing, and speaking: for these, the co-operation of the whole extended class of respiratory nerves is required.

Of Pathology, as illustrated by a Knowledge of the respiratory System of Nerves.

From all that has been said, it may be seen of what importance this system is to the continuance of life. The infant born without a brain can breathe if the origins of these nerves be entire. Wounds in the spine below these origins are not immediately fatal; but when inflicted on the part of the *medulla oblongata* giving origin to them, they cause instant death by suppressing at once the act of respiration in the nostrils, throat and wind-pipe, and the action of the muscles both without and within the chest. A young man was taken to the Middlesex Hospital, who had fallen upon his head. He soon recovered, and lay for some time in the hospital without exhibiting a symptom to raise alarm. He had given thanks to the assembled governors of the hospital; and when he returned to his ward to bid adieu to the other patients, he fell, and in the instant expired. It was found, on examination of his head, that the margins of the occipital hole had been broken; so that on turning his head the pieces were displaced, and closed and crushed the *medulla oblongata* as it passes from the skull.

A man was trundling a wheel-barrow in the street, and wishing to turn off the carriage way on to the flag-stones, he met with that resistance which obliged him to make several efforts to overcome it; at length drawing back the wheel-barrow he made a push, and succeeded: but the wheel running forwards, he fell, and remained motionless, and was found to be quite dead. The tooth-like process of the 2d vertebra of the neck had burst from the transverse ligament of the first. The impulse given to the head had done this violence, and had at the same time carried forward the spinal marrow against the process, on which it was crushed.

Disease influences these nerves differently from the other division of the nervous system. Their functions are left entire when the voluntary nerves have ceased to act, and they are sometimes strangely disordered, while the mind is entire in all its offices, and the voluntary operations perfect. In tetanus the latter are affected, and locked up in convulsions; in hydrophobia the former; hence the convulsions of the throat, the paroxysms of suffocation, the speechless agony, and the excess of expression in the whole frame, while the voluntary motions

motions are free. *Angina pectoris* would seem to proceed from an influence extending over these nerves and interrupting the vital operations*; and since we have seen that the division of a branch of the respiratory nerve of the face deprives it of all participation in the act of respiration and of all expression, we may ask, what would be the result of a more universal defect in the actions of this class of nerves but sudden death?

The *par vagum* being the great central nerve of this system and supplying the stomach, accounts for that extraordinary effect produced by a blow unexpectedly received on that region, which is a gasping for breath, and in some instances sudden death. The position of a patient under a fit of asthma, together with the other striking symptoms which mark its presence, indicate that this system of nerves is under inordinate influence.

The actions of sneezing and coughing, instead of being irregular or of the nature of convulsion, are an admirable provision for getting rid of irritating substances offending the air-passages; the extremity of one of the respiratory nerves being irritated occasioning all the muscles of respiration to be brought into action; the consideration of the many little muscles which require adjustment to produce the necessary changes in the direction of the stream of air for the above-mentioned purpose, must lead to the conclusion of the action being instinctive, ordered with the utmost activity, and very different from convulsion.

It was shown in the last paper, that the respiratory nerves of the face were essential to the actions of smiling, laughing, and weeping, as expressed in the countenance: it only remains to add, in the present one, that this applies equally to the same order of actions which takes place in the trunk, these being produced so very distinctly under those conditions of the mind, and precisely at the same time.

These respiratory Nerves are Organs of Expression.

We are now enabled to conceive why, in terror, a man stands with eyes intently fixed on the object of his fears; the

* Hysterical disorders also influence this system; and admitting that irritation reaches to the respiratory system, we may perceive how rapidly the change may be produced, from the convulsions of laughter to those of crying: this explains also the *subrisus* which arises from abdominal irritation, and the sardonic retraction of the muscles of the face produced by wounds of vital parts, and particularly of the diaphragm, together with the successive convulsive lifting of the shoulders accompanying wounds of the latter muscle.

eye-brows elevated, and the eye-balls largely uncovered; or why, with hesitating and bewildering steps, his eyes are rapidly and wildly in search of something. His mind we know is intent upon the objects of his apprehensions, and manifests a direct influence upon the outward organs. If we observe him further, there is a spasm at his breast; he cannot breathe freely; the chest remains elevated, and his respiration is short and rapid: there is a gasping and convulsive motion of his lips; a tremor on his hollow cheeks; a gulping and catching of his throat; his heart knocks at his ribs, while yet there is no force in the circulation, the lips and cheeks being ashy pale.

The same phænomena are presented by grief: indeed the respiratory nerves of the trunk, in like manner as those of the face, are the instruments of expression, from the smile upon the infant's cheek to the last agony of life. It is when the strong man is subdued by the mysterious influence of soul on body, and when the passions may be truly said to tear the breast, that we have the most afflicting picture of human frailty, and the most unequivocal proof that it is the order of functions which we have been considering that is then affected. In the first struggles of the infant to draw breath, in the man recovering from a state of suffocation, and in the agony of passion, when the breast labours from the influence at the heart, the same system of parts is affected, the same nerves, the same muscles, and the symptoms or characters have a strict resemblance.

Upon a careful review of all that has been said, the author has made it appear, that instead of the *par vagum* being the only respiratory nerve, it is in fact the central one of a system of nerves of great extent; and, further, that the vital organs of circulation and respiration do not, as has been supposed, depend chiefly upon the influence of the sympathetic nerve, but that they have an appropriate system; which, extricated as it now is from the confusion that encumbered it, may be seen to be superadded to the common animal attributes of feeling and agency: through this system we see as it were engrafted upon and superadded to the original nature, higher powers of agency corresponding to our condition of mental superiority: these are not the organs of breathing merely, but of natural and articulate language also, and adapted to the expression of sentiment, in the workings of the countenance and of the breast, that is, by signs as well as by words. So that the breast becomes the organ of the passions, and bears the same relation to the development of sentiments, as the organs of the senses do to the ideas of sense.

XX. *On Mr. SAMUEL SEAWARD'S Claim to the Invention of a Hydro-pneumatic Pump for compressing Gases, &c. By Mr. JOHN MARTINEAU.*

To the Editors of the Philosophical Magazine and Journal.

Gentlemen,

I OBSERVE in your last Number a drawing and description of a pump for condensing gases, by Mr. S. Seaward, which pump he states to be his invention.

As far as I am myself concerned, I should have hardly thought it worth while to contradict his statement; but I cannot in justice to yourself allow your respectable Journal to be made the vehicle for conveying a falsehood to the public.

This pump was constructed at the manufactory of which I am a proprietor, during the time that Mr. Seaward filled a situation as draughtsman in it. In that capacity he made the necessary drawings connected with it; but I do most positively assert, that he did not invent or suggest any one essential part of it.

I content myself with simply stating the above facts,
And remain

Your most obedient servant,

City Road, Aug. 10, 1824.

JOHN MARTINEAU.

XXI. *An Attempt to explain the Action of the Voltaic Pile. By Mr. THOMAS POLLOCK.*

THE power of the Voltaic pile as an instrument of chemical analysis is owing to the influence its action produces upon the radiant matter which common matter contains, and to which its various forms are owing, and which, when in motion produces heat.

The action of the pile may be readily explained when one fact is previously assented to,—that a radiant matter capable of producing heat, when in motion, pervades all the matter, solid, fluid and gaseous, of the universe; and that no motion whatever can take place upon the surface of our globe without producing a change in the distribution of this general pervading principle. If a gas become a fluid, or a fluid a solid, there is a diminution of capacity for heat; there is contraction of volume, and the form this matter has now assumed, owing to contraction, demands less of this general pervading principle, and heat is presented to surrounding bodies. If this change take place with rapidity, and bodies possessing a great capacity for heat,

as water or moisture, be absent, light will frequently result; hence the electric spark. While, on the contrary, if a solid become a fluid, or a fluid a gas, there is an increase of capacity, there is expansion of volume, and the form now assumed will, owing to this expansion, demand more of this pervading principle, and cold will be presented to, or their pervading heat abstracted from, surrounding bodies. Moreover, if a gas merely contract or expand without assuming either the fluid or solid form, the same effect will be produced upon the pervading principle of heat in surrounding bodies. Here, perhaps, the explosion of euchlorine may be objected as an instance of expansion attended by heat and light; but this change takes place with rapidity, and the abstraction of the radiant principle from surrounding bodies will likewise be effected with rapidity, producing light and heat.

There is no necessity for supposing the existence of heat, light, an electric, galvanic, or perhaps a magnetic fluid distinct from this pervading principle; they are all branches from the same root. Electric or galvanic attraction between bodies is the result of their containing different proportions of the pervading principle; and by the electric spark the excess is given off and an equilibrium is restored. Thus the thunder cloud being formed from vapour in the atmosphere, there is a contraction of volume, an excess of the pervading principle, which, by being transmitted to the earth beneath, produces lightning.

Previously to making an attempt to explain the action of the Voltaic pile, it may be necessary to inquire upon what conducting power and capacity for heat depend. Conducting power appears to be the reverse of capacity for heat, as the best conductors have generally the worst capacity. In conductors, as metals, attraction predominates; but in bodies possessing the greatest capacity, as gases, repulsion of particles predominates. Metals are the densest bodies known, at least those forming a component part of the pile. Density must depend upon a strong attraction between the particles of the substance.

Conducting power appears, then, to be the consequence of the strong mutual attraction existing between the particles of matter, as in a metal; because if a metal, by exposure to a higher temperature, become expanded, yet, when exposed to a lower temperature, it will again contract more suddenly than a non-conducting substance, because the attraction between the particles of a conducting substance must be comparatively stronger than that of a non-conducting substance, as the superior density of the former demonstrates: and as the
particles

particles of a metal must contract more suddenly than those of any other substance, heat will be imparted to surrounding bodies, and to that part of the metal which has not been equally exposed to the heat-making body, with greater rapidity. Thus, conducting power appears to depend upon the particles of the conductor being nearer each other, thereby producing a more rapid contraction after being heated.

Capacity for heat appears, then, to be the consequence of the greater want of attraction between the particles of the substance than of a conductor; for if a substance possessing a greater capacity do expand by exposure to a higher temperature, yet by exposure to a lower temperature, it will, owing to the greater want of attraction, unlike the metals, not contract in the same sudden manner they do, and therefore cannot be so powerful a conductor. Thus, owing to the greater mutual attraction between the particles of a conductor, metals possess the least capacity for heat of all the forms of matter. In water these two powers are more equally blended than in any other body; it possesses a greater conducting power than any other fluid of equal density, and has a great capacity for heat. It exists in three forms, solid, fluid and gaseous, at a less variation of temperature than any other fluid compounds, and, by the action of heat alone, differs from all others in being unalterable in composition.

The Voltaic pile consists of a number of series, generally about 200, arranged in the form of a pile; each series consisting of zinc, silver or copper, both about the size of a half crown, and cloth of the same size moistened with some saline or acid solution, as of nitre, common salt, or sal ammoniac, sulphuric, nitric or muriatic acid. This apparatus is variously arranged for the sake of convenience, but the principle is still the same; as by arranging the plates of the two metals soldered together cross-ways in a wooden trough, and filling the interstices with the saline or acid solution; if the hands moistened be applied to each extremity of the pile, a shock will be perceived.

If two platina wires, one in contact with the zinc extremity, the other with the copper extremity, be connected by means of a small piece of charcoal, the charcoal will be ignited.

If the wires be immersed in the same portion of water, oxygen will be given off at the positive wire, that connected with the zinc extremity; and hydrogen gas at the negative wire, that connected with the copper extremity.

If the wires be introduced into strong acid solutions, oxygen separates at the positive wire, and the inflammable component at the negative wire. Strong saline solutions are

acted upon in a similar way. Solution of muriatic acid in water gives off chlorine at the positive and hydrogen at the negative pole.

By the action of the Voltaic apparatus, the metals of the alkalis and alkaline earths, and boron, may be separated from their combinations with oxygen; sulphur and carbon, from their combinations with hydrogen.

The greater the number of the series, the more energetic will be the action of the apparatus.

By keeping in mind that the pile itself is pervaded by a radiant matter which by its motion can produce heat, the cause of its power may be traced out.

The action going on in each series between the metals and acid or saline solution, should now be considered.

First, the water is decomposed, by the union of some of the zinc with the oxygen of the water, and hydrogen gas given off from the surface of the copper; the acid then combines with the oxide of zinc, and remains in solution.

That portion of the metal, zinc, forming the oxide, by changing the conducting for the non-conducting form, as it exists in the newly formed solution, undergoes an expansion, and an increased capacity for heat; and the pervading heat which this increase demands will be supplied from that substance with which it is in the most intimate state of contact, which is the remaining metal, zinc: this zinc will in its turn instantly attempt to remunerate itself at the expense of that conducting substance with which it is in contact, which is the copper. The oxide of zinc will unite as soon as formed with the acid in the solution; there is now a diminution of capacity, a contraction, and the heat thus liberated is seized upon by that body present, which has the greatest capacity for it, which is the hydrogen gas. This gas containing an excess of what the copper is deficient in, they attract each other; and the equilibrium being restored, the hydrogen gas is given off from the surface of the copper.

Here, perhaps, it may be considered strange that the hydrogen, being produced in close contact with the zinc, should be elicited from the surface of the copper in preference to that of the zinc; but the very instant that the zinc suffers a loss of radiant matter, that very instant will this loss be supplied by the copper, as metals are conductors, and the copper remunerating itself at the expense of those bodies in its vicinity, as the solution, the hydrogen will naturally be attracted by it, and repelled from that part where the saline compound of zinc must be formed, which must be in contact with the zinc.

Thus, as it appears that in the series of the zinc, copper and solution,

solution, the conducting metals suffer a loss of their natural quantity of radiant matter, capable of producing heat, it is reasonable to suppose, that when a number of these series are brought within the range of the conducting influence of each other, as in the pile, the effects produced must be heightened; as the metals, such delicate tests of the presence of radiant matter, must be peculiarly sensible of the diminution of the radiant matter of those conducting bodies in their vicinity; as in the adjoining series of the pile.

The energy of the pile as a chemical agent increases in proportion to the number of the series; and when the supply of radiant matter capable of producing heat, which the metals in all the different series of the pile demand, owing to the change going on in the pile, is concentrated by being conveyed into it along two small platina wires, and when this supply is derived from a small mass of non-conducting matter, as the hydrate of potassa, the action of the pile must be almost irresistible, and the non-conducting compound will be as it were torn asunder by virtue of two attractions, by the abstraction of that radiant matter, or latent heat, upon which its very existence in the non-conducting form depends; and by which two attractions its matter is divided into two parts, which under other circumstances possess a strong attraction for each other, but here are attracted by the positive and negative poles of the pile.

Thus, the change which matter undergoes in its relations to temperature, when exposed to the action of the wires of the apparatus, is the very reverse of that going on in the pile; there, the quantity of conducting matter is diminished by the action of the menstruum upon the metal zinc: here, on the contrary, by the action of the two wires upon the hydrate of potassa, conducting matter is formed, as potassium is produced.

Why, it may here be inquired, should a metal, as potassium, be separated at the negative, and oxygen at the positive wire? why should this preference be given by each body to each of these wires? A current of radiant matter proceeds from the negative towards the positive extremity, where, by an accumulation, a tendency is imparted to bodies, such as a metal, to enter into a state possessing a greater capacity for heat, or in other words to form an oxide; while metallic matter, as potassium, is separated at the negative extremity, because, instead of an accumulation, there is a deficiency. This circumstance of excess of the radiant principle in one body, and its deficiency in another, is the cause of attraction in general. To explain more fully: the potassium being formed from the non-conducting

ducting hydrate of potassa, suffers a diminution of capacity for heat, while the oxygen gas gains an increase: thus the potassium has an excess of radiant matter to impart, while at the negative extremity of the pile there is a deficiency; therefore the potassium and copper naturally attract each other. The reason why oxygen should be attracted by that pole where radiant matter is in excess, and thereby have a tendency imparted to it of combining with metallic matter, may readily be admitted. Why in common cases do we heat a metal in order to combine it with oxygen? Is it to furnish the latent heat which the increase of capacity of the newly formed oxide demands? Yes.

East Smithfield, July. 28, 1824.

THOMAS POLLOCK.

XXII. *Of Semi-decussation of the Optic Nerves.* By WILLIAM HYDE WOLLASTON, M.D. V.P.R.S.*

WHETHER we consider the astonishing subtlety of that medium which renders visible to us objects existing at the most immeasurable distances from us, or that delicately constituted organ which, by its general structure, collects the rays of light, and by a nice adaptation of its parts concentrates their force on the sentient fibres of the retina, expanded over its inner surface, we can feel no surprise that such great talents should have been devoted to investigate the curious properties of the one, or that the structure of the other should have been examined with so much assiduity.

The keenness of inquiry manifested by the cultivators of anatomy, in observing the most minute parts that have escaped the notice of their predecessors, shows that any addition to the common stock of our information on this subject will be gratifying to a certain portion of the members of this Society, and probably not uninteresting to the Society at large.

It is not my object, in the present paper, to examine either the *first* effect of the cornea in rendering the rays of light convergent, or the power of the crystalline lens in *finally* bringing them to a focus on the retina. It is not my intention to investigate whether the adaptation of the eye to different distances is effected by alteration of the *form* of the lens from its own muscular structure, or by alteration of its *place*, from the agency of other muscles. Nor do I mean to consider either the *involuntary* motions of the iris dependent on the quantity of light present, or that *voluntary* contraction of it by which we adapt the aperture of the pupil for distinct vision

* From the Philosophical Transactions for 1824, Part I.

at different distances, limiting thereby, what in optics is termed the spherical aberration of the lens.

The subject of my inquiry relates solely to the course by which impressions from images perfectly formed are conveyed to the sensorium, and to that structure and distribution of the optic nerves on which the communication of these impressions depends.

Without pretending to detect by manual dexterity as an anatomist, the very delicate conformation of the nerves of vision, I have been led, by the casual observation of a few instances of diseased vision, to draw some inferences respecting the texture of that part which has been called the decussation of the optic nerves, upon which I feel myself warranted to speak with some confidence.

It is well known that in the human brain these nerves, after passing forwards to a short distance from their origin in the thalami nervorum opticorum, unite together, and are, to appearance, completely incorporated; and that from this point of union proceed two nerves, one to the right, the other to the left eye.

The term decussation was applied to this united portion, under the supposition that, though the fibres do intermix, they still continue onward in their original direction, and that those from the right side cross over wholly to supply the left eye, while the right eye is supplied entirely from fibres arising from the left thalamus.

In this opinion, anatomists have felt themselves confirmed by the result of their examination of other animals, and especially that of several species of fish, in which it is distinctly seen that the nerves do actually cross each other as a pair of separate cords, lying in contact at their crossing, but without any intermixture of their fibres.

In these cases it is most indisputably true, that the eye upon the right side of the animal does receive its optic nerve from the left side of the brain, while that of the left eye comes from the right side; but it is not a just inference to suppose the same continuity preserved in other animals, where such complete separation of the entire nerves is not found.

On the contrary, I not only see reason, from a species of blindness which has happened to myself more than once, to conclude, that a different distribution of nerves takes place in us, but I think my opinion supported by this evident difference of structure in fishes.

It is now more than twenty years since I was first affected with the peculiar state of vision to which I allude, in consequence of violent exercise I had taken for two or three hours before.

before. I suddenly found that I could see but half the face of a man whom I met; and it was the same with respect to every object I looked at. In attempting to read the name JOHNSON, over a door, I saw only SON; the commencement of the name being wholly obliterated to my view. In this instance the loss of sight was toward my left, and was the same whether I looked with the right eye or the left. This blindness was not so complete as to amount to absolute blackness, but was a shaded darkness without definite outline. The complaint was of short duration, and in about a quarter of an hour might be said to be wholly gone, having receded with a gradual motion from the centre of vision obliquely upwards toward the left.

Since this defect arose from over fatigue, a cause common to many other nervous affections, I saw no reason to apprehend any return of it, and it passed away without need of remedy, without any further explanation, and without my drawing any useful inference from it.

It is now about fifteen months since a similar affection occurred again to myself, without my being able to assign any cause whatever, or to connect it with any previous or subsequent indisposition. The blindness was first observed, as before, in looking at the face of a person I met, whose *left* eye was to my sight obliterated. My blindness was in this instance the reverse of the former, being to *my right* (instead of the left) of the spot to which my eyes were directed; so that I have no reason to suppose it in any manner connected with the former affection.

The new punctum cæcum was situated alike in both eyes, and at an angle of about three degrees from the centre; for, when any object was viewed at the distance of about five yards, the point not seen was about ten inches distant from the point actually looked at.

On this occasion the affection, after having lasted with little alteration for about twenty minutes, was removed suddenly and entirely by the excitement of agreeable news respecting the safe arrival of a friend from a very hazardous enterprise.

In reflecting upon this subject, a certain arrangement of the optic nerves has suggested itself to me, which appears to afford a very probable interpretation of a set of facts, which are not consistent with the generally received hypothesis of the decussation of the optic nerves.

Since the corresponding points of the two eyes sympathize in disease, their sympathy is evidently from structure, not from mere habit of feeling together, as might be inferred, if reference were had to the reception of ordinary impressions alone.

alone. Any two corresponding points must be supplied with a pair of filaments from the same nerve, and the seat of a disease in which similar parts of both eyes are affected, must be considered as situated at a distance from the eyes at some place in the course of the nerves where these filaments are still united, and probably in one or the other thalamus nervorum opticorum.

It is plain that the cord, which comes finally to either eye under the name of optic nerve, must be regarded as consisting of two portions, one half from the right thalamus, and the other from the left thalamus nervorum opticorum.

According to this supposition, decussation will take place only between the adjacent halves of the two nerves. That portion of nerve which proceeds from the right thalamus to the right side of the right eye, passes to its destination without interference; and in a similar manner the left thalamus will supply the left side of the left eye with one part of its fibres, while the remaining halves of both nerves in passing over to the eyes of the opposite sides must intersect each other, either with or without intermixture of their fibres.

Now, if we consider rightly the facts discovered by comparative anatomy in fishes, we shall find that the crossing of the entire nerves in them to the opposite eyes, is in perfect conformity to this view of the arrangement of the human optic nerves. The relative position of the eyes to each other in the sturgeon, is so exactly back to back, on opposite sides of the head, that they can hardly see the same object; they can have no points which generally receive the same impressions as in us; there are no corresponding points of vision requiring to be supplied with fibres from the same nerve. The eye which sees to the left has its retina solely upon its right side; and this is supplied with an optic nerve arising wholly from the right thalamus; while the left thalamus sends its fibres entirely to the left side of the right eye for the perception of objects situated on the right. In this animal, an injury to the left thalamus might be expected to occasion entire blindness of the right eye alone, and want of perception of objects placed on that side. In ourselves, a similar injury to the left thalamus would occasion blindness (as before) to all objects situated to our right, owing to insensibility of the left half of the retina of both eyes.

A disorder that has occurred within my own knowledge in the case of a friend, seems fully to confirm this reasoning, as far as a single instance can be depended upon. After he had suffered severe pain in his head for some days, about the left

temple, and toward the back of the left eye, his vision became considerably impaired, attended with other symptoms indicating a slight compression on the brain.

It was not till after the lapse of three or four weeks that I saw him, and found that, in addition to other affections which need not here be enumerated, he laboured under a defect of sight similar to those which had happened to myself, but more extensive, and it has unfortunately been far more permanent. In this case the blindness was at that time, and still is, entire, with reference to all objects situated to the right of his centre of view. Fortunately, the field of his vision is sufficient for writing perfectly. He sees what he writes, and the pen with which he writes, but not the hand that moves the pen. This affection is, as far as can be observed, the same in both eyes, and consists in an insensibility of the retina on the left side of each eye. It seems most probable, that some effusion took place at the time of the original pain on that side of the head, and has left a permanent compression on the left thalamus. This partial blindness has now lasted so long without sensible amendment, as to make it very doubtful when my friend may recover the complete perception of objects on that side of him.

In reviewing the several phænomena that I have described, we find partial blindness occurring at the same time in both eyes. This sympathy from disease is readily explained, on the supposition that the parts which sympathize receive their nerves from the same source, while the opposite halves of the eyes, which are not at the same time similarly affected, are supplied from an opposite source; and the inference is immediate, that in common vision also the sympathy of corresponding points, which receive similar impressions from the same object, is dependent on the arrangement of nerves thus detected by disease.

We find moreover in the sturgeon, (and it is the same in some other fishes,) whose eyes can scarcely see the same object at once, and have no corresponding points which ordinarily sympathize, that the two eyes do not receive any nervous fibres from the same source; but one eye receives its nerve wholly from one side, and the other from the other side of the brain.

From the structure of these fish we learn distinctly, that the perception of objects toward one side is dependent on nerves derived from the opposite side of the brain; and in the last case of diseased vision above related, we find apparent injury to one side of the brain, followed by blindness toward the opposite side of the point to which both eyes are directed.

A series of evidence in such apparent harmony throughout, seems clearly to establish that distribution of nerves I have endeavoured to describe, which may be called the semi-decusation of the optic nerves.

On single Vision with two Eyes.

So long as our consideration of the functions of a pair of eyes is confined to the performance of healthy eyes in common vision, when we remark that only one impression is made upon the mind, though two images are formed at the same moment on corresponding parts of our two eyes, we may rest satisfied in ascribing the apparent unity of the impression to habitual sympathy of the parts, without endeavouring to trace further the origin of that sympathy, or the reason why, in infancy, the eyes ever assume one certain direction of correspondence in preference to squinting.

But, when we regard sympathy as arising from structure, and dependent on connection of nervous fibres, we therein see a distinct origin of that habit, and have presented to us a manifest cause why infants first begin to give the corresponding direction to their eyes, and we clearly gain a step in the solution, if not a full explanation, of the long agitated question of single vision with two eyes.

It may perhaps to some persons appear surprising, that so many as three instances of a disorder which they presume to be rare, should have been witnessed by one individual; but I apprehend, on the contrary, this half-blindness to be far more common than is generally supposed; and I might with as much reason express surprise at its having so far escaped notice*, were I not aware how many facts commonly remain disregarded, merely for want of explanation. It is evident that I once, and for a long time, overlooked the inference that is to be drawn from this affection; and if the disorder had not happened to me a second time, I might never have reconsidered its cause.

Even since the preceding pages were written, I have met with two more cases of this disease. One of my friends has been habitually subject to it for sixteen or seventeen years, whenever his stomach is in any considerable degree deranged.

* Richter, in the third volume of his *Elements of Surgery*, has a chapter on half-blindness, and part of it relates to what he terms *amaurosis dimidiata*. From one instance there given, he seems to have seen some cases similar to those I have described; but he has not noticed the corresponding affection of the two eyes, or considered the sympathy between them.—*Anfangs-gründe Der Wundartzneykunst*, vol. iii. chap. 16, p. 478.

In him the blindness has been invariably to his right of the centre of vision, and, from want of due consideration, had been considered as temporary insensibility of the right eye; but he is now satisfied that this really is not the case, but that both eyes have been similarly affected, with half-blindness. This symptom of his indigestion usually lasts about a quarter of an hour or twenty minutes, and then subsides, without leaving any permanent imperfection of sight.

I have not seen the subject of the 5th case; but I am informed that he has had many returns of this affection, generally attended with head-ach, and always lasting about twenty minutes, with very little variation.

XXIII. *Observations on the Heights of Places in the Trigonometrical Survey of Great Britain, and upon the Latitude of Arbury Hill. By B. BEVAN, Esq. Communicated by Sir H. DAVY, Bart. P.R.S.**

THE Trigonometrical Survey of Great Britain having from time to time engaged the attention of the Royal Society, and circumstantial particulars of this great national undertaking having occupied the pages of the Philosophical Transactions, I beg leave to submit a few observations on that subject to the consideration of the Society.

The result of the survey, relative to the different sections of the meridian, in this country, has not altogether proved so satisfactory as might have been expected.

I have lately examined the calculations affected by the observations made at Arbury Hill in the county of Northampton, with some hope of discovering the means of reconciling the anomaly in that part of the meridian.

I have been at the expense of having the height of this station determined by accurate levelling to the Grand Junction Canal; from which, and the known difference of level of the various canals connected with this, I have been able to find the *relative* height of this station, with most of the important objects in the counties of Northampton, Buckingham, and Bedford.

From this operation of levelling, I found the country to the north of Arbury station, suddenly to fall about 400 feet, and continue at this depressed state for 9 or 10 miles. Such a defect of matter, to the north of the station, was in itself a strong ground for supposing a deflection of the plumb-line to the southward. To ascertain if this supposition were supported by the trigonometrical operations, I calculated the la-

* From the Philosophical Transactions for 1823, Part I.

titude of Arbury station, from the latitude of Blenheim, as determined by previous observation, independent of any astronomical observation made at Arbury, and find it 5 seconds LESS than shown by the zenith sector; giving countenance to the probability of local attraction by the high land to the south of the station, which will appear by the following calculation; in *Trigonometrical Survey*, vol. ii. p. 137, the latitude of Blenheim by observation is stated as $51^{\circ} 50' 24''.9$, or nearly $51^{\circ} 50' 25''$.

The measured distance, on the meridian, from Blenheim to Arbury, is 139822, deduced from vol. ii. part 2, p. 107; dividing this distance by 60881.7, according to a table in vol. i. part 1, p. 168, corresponding to the middle latitude between Blenheim and Arbury, and multiplying the quotient by $10''$, we obtain the difference of latitude = $^{\circ} 22' 58''$.
 this quantity added to $51\ 50\ 25$
 gives for the latitude of Arbury $52\ 13\ 23$
 being $5''$ less than by the zenith sector. It is true that Colonel Mudge corrected the latitude of Blenheim, from the *Trigonometrical Survey*, to $51^{\circ} 50' 28''$, and in this case the computed latitude of Arbury would come out near 3 seconds less than found by the zenith sector. In vol. ii. part 1, page 118, the latitude of Arbury, as derived from Dunnose meridian, is given $52^{\circ} 13' 26''.6$
 afterwards . $52\ 13\ 28\ .2$ from observation*

1.6 or $1\frac{1}{2}$ second south of the observed latitude; all concurring to prove that the observed latitude by zenith sector falls to the north of the calculated, or that the deflection of the plumb-line was to the south. Taking, therefore, the table above referred to in vol. i. part 1, p. 168, and considering the latitudes of the following stations to be as below :

Dunnose	$51^{\circ} 37' 7''$
Greenwich	$51\ 28\ 39\frac{1}{2}$
Blenheim	$51\ 50\ 28\frac{1}{2}$
Arbury	$52\ 13\ 26\frac{1}{2}$
Clifton	$53\ 27\ 20\frac{3}{4}$

and calculating the length of a degree, in their respective middle points, they will be found to correspond with the said table, and maintain a *regular increase to the northward*, agreeing with the assumed general figure of the earth: the above assumption indicates an error of $10\frac{3}{4}''$ at Clifton, and $1\frac{3}{4}$ at

* Vol. ii. part 2, p. 109, Dunnose is stated to be . . . $50^{\circ} 37' 8'' .2$
 p. 107, from Dunnose to Arbury is . . . $1\ 36\ 19\ .98$
 $52\ 13\ 28\ .18$
Arbury,

Arbury, neither of which is more than might be expected from the visible inequality of the contiguous land.

The result of the operations north of Clifton I have not had an opportunity of ascertaining; but it appears to me that a few more observations by the zenith sector, at other stations, would remove much of the apparent ambiguity at present attached to this interesting question.

Knowing the goodness of the instrument used in the Survey, and the great skill and attention observed by the persons engaged, I have great confidence in the general result of the terrestrial department. I should have been doubly gratified if I could have said as much on the determination of the *heights* of the stations.

Availing myself of the levels through a long district of the Grand Junction Canal, I have been at the trouble of levelling from the following stations, viz.

Wendover Down,
Kensworth,
Bowbrick Hill, and
Arbury Hill,

to the nearest point of the said Canal, and thus, by means of the known level of the different parts of the Canal, to obtain the *relative heights* of the above-mentioned stations.

And as a comparison will be more readily made from a table of heights expressed in positive numbers, I shall assume the highest point of the summit of said Canal to be 402 feet above the level of the sea at low water spring tides: with this assumption, the heights of the several stations, in feet, above low water mark, will be as follows:

Wendover Station . . .	861
Kensworth ditto . . .	809½
Bowbrick Hill . . .	771½
Arbury Hill . . .	740½

The heights of these stations published in the Philosophical Transactions, are as below: in vol. iii. p. 302.

Wendover . . .	905
Kensworth . . .	904
Bowbrick Hill . . .	683
Arbury Hill . . .	804

these will average about 78 feet higher than in the table above.

I have also levelled from the summit of the Regent's Canal, to the mouth of the fixed cannon at King's Arbour, or the upper end of the base on Hounslow Heath, and upon the same data this point will be 90¾ feet above low water mark.

In vol. i. p. 173, Colonel Mudge gives $91\frac{1}{4}$ for its height, which differs only by half a foot.

But at page 266 it is stated to be 118 feet, being 27 feet above the proper height. Again, in vol. iii. p. 307, it is stated to be 132 feet, or $41\frac{1}{4}$ too high.

The grounds of my assumption of 402 feet being the height of the Grand Junction Canal summit, near Tring, are these:

The range of tide, from low water spring tides at sea, to high water near Somerset House, I presume to estimate $19\frac{1}{3}$ feet; from this point to the Regent's Canal summit will be found $83\frac{1}{6}$ feet; from this level I apply the revised section of the Grand Junction Canal = $299\frac{1}{2}$ to the summit near Tring, making together 402 feet as above.

From these levels it will appear, that Wendover Station above Brickhill is $861 - 571\frac{1}{2} = 289\frac{1}{2}$. Colonel Mudge's numbers give . . . $905 - 683 = 222$

	$67\frac{1}{2}$	error
Arbury above Brickhill	$740\frac{1}{2} - 571\frac{1}{2} =$	69
Colonel Mudge . . .	$804 - 683 =$	121
	Error	<u>52</u>
Wendover above Arbury	$861 - 740\frac{1}{2} =$	$120\frac{1}{2}$
Colonel Mudge . . .	$905 - 804 =$	101
	Error	<u>$19\frac{1}{2}$</u>

Some fresh observations with the zenith sector made at Blenheim, and Sutton, would offer a fine check to the latitude of Arbury; and also at Highbeach, and Botley Hill, a check to the latitude of Greenwich would be readily obtained.

Leighton, Bedfordshire, February 1822.

B. BEVAN.

XXIV. Notices respecting New Books.

THE Transactions of the Horticultural Society, vol. v. Part IV., have just appeared. The following are the contents:—

On the Cultivation of the Yellow Rose, and of the tender Chinese Roses, by budding on the Musk Cluster Rose. By John Williams, Esq.—On the Cultivation of the *Arachis hypogæa*. By Mr. John Newman, Gardener to the Hon. Robert Fulke Greville.—On the Treatment of the Banyan Tree (*Ficus Indica*) in the Conservatory. By Peter Rainier, Esq. Captain R.N.—Further Notes on the Utility of the Grafting Wax, described in a former Paper. By David Powel, Esq.—Some Remarks on the supposed Influence of the

the Pollen, in cross breeding, upon the Colour of the Seed-coats of Plants, and the Qualities of their Fruits. By Thomas Andrew Knight, Esq. F. R. S. &c. President.—An Account of a new Variety of Plum, called the Downton Imperatrice. By the President.—Observations upon the Effects of Age upon Fruit Trees of different Kinds; with an Account of some new Varieties of Nectarines. By the President.—On a hybrid Amaryllis, produced between *Amaryllis vittata* and *Amaryllis Reginâ-vittata*. By James Robert Gowen, Esq.—On the Cultivation of the Pine Apple. By Mr. Alexander Stewart, Gardener to Sir Robert Preston, Bart. at Valleyfield, Perthshire.—Description of a Pear Tree, on which the Operation of Reverse Grafting has been performed. By Mr. William Balfour, Gardener to the Earl Grey, at Howick, in Northumberland.—Notice of new or remarkable Varieties of Fruits, ripened in the Summer and Autumn of the year 1822, which were exhibited at Meetings of the Horticultural Society:—A Description of some new Pears. By Mr. John Turner, Assistant Secretary.—Account and Description of five new Chinese Chrysanthemums; with some Observations on the Treatment of all the Kinds at present cultivated in England, and on other Circumstances relating to the Varieties generally. By Joseph Sabine, Esq. Secretary.—A Note on the Pears called *Silvanges*, and particularly on the *Silvange Verte* (Green *Silvange*). By Mons. Charles Francis Pierard, of Manjouy, near Verdun-sur-Meuse.—On the Preparation of Strawberry Plants for early Forcing. By the President.—On Transplanting Peas for early Crops. By Mr. Daniel Judd.—Some Account of the Edible Fruits of Sierra Leone. Drawn up by Joseph Sabine, Esq. from the Journal and personal Communication of Mr. George Don.—Directions for the Management of the Hot-house Fire-places, that are constructed with double Doors and Ash-pit Registers. By William Atkinson, Esq.—On Forcing Grapes, as practised in Denmark. By Mr. Peter Lindegaard, Gardener to His Majesty the King of Denmark, at the Palace at Rosenberg. On Fig-trees, and an Account of their Cultivation in a Fig-house, in the Garden of the late Earl of Bridgewater, at Ashridge in Hertfordshire. By Joseph Sabine, Esq., Secretary.—Notices of Communications to the Horticultural Society, between May 1st 1821 and January 1st 1822, of which separate Accounts have not been published in the Transactions. Extracted from the Minute Books and Papers of the Society.—Description of a Vinery, and Mode of Training practised in it. By Mr. William Beattie, Gardener to the Earl of Mansfield, at Scone, near Perth.—Description of a Pine-

a Pine-house and Pits. By Charles Holford, Esq. F.R.S.—
Description of an Apparatus for Ventilating Hot-houses. By
Mr. George Mugliston of Repton, near Derby.

Recently published.

Mathematical Tables: containing improved Tables of Logarithms of Numbers, Logarithmic Sines, Tangents and Secants. By William Galbraith.

De Interpretibus et Explanatoribus Euclidis Arabicis Schediasma Historicum: auct. J. C. Gartz. 4to. Halle, 1823. Sumptibus auctoris.

Lehrbuch der Reinen Chemie. Elements of Theoretic Chemistry, by Dr. Bischoff, Professor of Chemistry and Technology at Bonn. 1824; Weber.

Magazin for Naturvidenskaberne. Magazine for Natural Sciences, by Professors Lund, Hansteen, and Maaschman. Two volumes and a part of a third of this Norwegian Journal have been published at Christiania.

Sulla Esistenza e Proprietà del Calorico, &c. A Physico-medical Treatise on the Existence and Properties of Caloric. By Dr. Louis Forni. Turin, 1824.

Observations sur la Nomenclature et le Classement des Roses. On the Nomenclature and Classification of Roses. By J. P. Vibert. Paris, 1824.

Mémoire sur un Niveau à Bulle d'Air et à Lunettes de nouvelle construction. On a Spirit-Level of a novel construction. Paris, 1824. Didot.

In the Press.

Commentaries on the Diseases of the Stomach and Bowels of Children. By Robley Dunglison, M.D. &c.

Capt. David Thomson, Inventor of the Longitude Scale, has, in the Press, a Work on the Methods of finding the Longitude at Sea, by Lunar Observations and Chronometers.

The Papers printed in the Transactions of the Royal Society, detailing the Discoveries of the Functions of the Nerves, will be immediately republished, with Notes and a general Introductory view of the Nervous System, by Mr. Charles Bell, Professor of Anatomy and Surgery to the Royal College of Surgeons, and Surgeon to the Middlesex Hospital.

Mr. Partington of the London Institution has nearly ready for publication, in a small Volume, a new Edition of that very valuable little Work, the Marquis of Worcester's Century of Inventions; from the original MS.: with Historical and Explanatory Notes.

ANALYSIS OF PERIODICAL WORKS ON NATURAL HISTORY.

Curtis's British Entomology.

No. 8. contains the following subjects :

Pl. 31. *Buprestis nitidula*. A species new to this island, taken in the New Forest from the flowers of the White-thorn. The brilliancy of the insect, as well as the rarity of all the individuals composing the genus, renders it an interesting and valuable acquisition to our cabinets and Fauna.—Pl. 32. *Hydrometra stagnorum*. We do not recollect to have seen a good figure before of this curious but common insect, the account and plate of which are here rendered more valuable by a figure of the winged sex from the cabinet of the British Museum, the only collection where it is to be found.—Pl. 33. *Bupalus favillacearius* (the Gray Scollop Moth). A male and female of this rare and elegant species are here given; and although Moses Harris had figured the female, and Donovan the male under the name of *Phalæna mediopunctaria* (v. xiii. 461. 1.), as they were not aware of there being sexes of the same moth, this plate, which is remarkable for delicate execution, will be an acquisition to the Lepidopterist.—Pl. 34. *Milesia speciosa*. A splendid insect from the New Forest, of a genus to which more British species will very probably shortly be added, as there are several others described by Meiger in his work upon the European Diptera.

The Botanical Magazine. No. 451.

Pl. 2503. *Astrapæa Wallichii*, described in Lindley's *Collectanea*.—*Erinus Lychnidea*, to which in preference to *africanus*, Burman's *L. villosa* is referred.—*Ixora barbata*, from the Botanic Garden, Calcutta.—*Pedicularis canadensis*: the leaves in the figure are opposite, as also in two specimens in the Banksian Herbarium, though Kalm describes them as alternate.—*Fuchsia decussata*, raised in the Edinburgh garden from seeds sent from Chili in 1822.—*Arum bulbiferum*, "acaule, radice tuberosâ, foliis decompositis bulbiferis; spathâ cucullatâ spadice cylindraceo parum longiore.—*Roxb. Flor. Ind. inedit.*" A magnificent Bengal species; the leaf spreads over an area of several square feet.

The Botanical Register. No. 114.

Pl. 817. *Aëranthes grandiflora*, "foliis apice bilobis valde inæqualibus scapo radicali vaginato debili brevioribus, calcare emarginato:" a singular Orchideous plant which Mr. Lindley considers as belonging to the same section of *Epidendrææ* with *Aërides*, together with seven others which he enumerates. To this new genus proposed by Mr. Lindley he also refers two tropical species described by M. Petit-Thouars.—*Dendrobium arachnitis*, and *Angraecum sesquipedale*. "So little," he says, "has hitherto been done in describing the Orchideous plants of tropical countries, that new forms are continually presenting themselves, and requiring the establishment of new genera for their reception. The distinctions upon which these are to be founded, however minute they may occasionally appear, are singularly permanent and decisive."—*Iris nepalensis*, "cristata, scapo bifloro, foliis falcatis brevioribus, spathâ diphyllâ perianthio violaceo appressâ unguium sepalorum longitudine." A handsome species received from Dr. Wallich.—*Pæonia cretica*. Mr. Lindley states that after repeated comparisons of the many supposed species in a living state, only twelve, which he enumerates, can be considered distinct. The present plant is var. β of the *arietina* of Anderson, *Linn. Trans.*—*Coronilla juncea*, a native of the south of France.
—*Zephy-*

—*Zephyranthes rosea*, “foliis humifusis linearibus scapo unifloro brevioribus, perianthio expanso: sepalis ovalibus apiculatis, spathâ bifidâ apice carnosâ.” A beautiful bulbous plant brought from the Havannah by Mr. G. Don. Mr. Lindley approves of the separation, from the old genus *Amaryllis*, of the group to which Mr. Herbert has given this name, and which “may be safely characterized by their nearly regular flowers, which have a vertical or nearly vertical position, and by their stamens not being bent to one side and unequal in length, but equal and spreading equally, with the exception of that which is opposite to what would be the upper segment of the *perianthium*, if the flower were horizontal.” After a handsome commendation of Mr. Herbert’s work, we have the following just remark: “This is one of the many genera which confirm the opinion held by Linnæus, that a few well selected words are abundantly sufficient for a generic or specific definition:.... there can be no comparison between the neatness and decision of his characters, and the unwieldy lumbering *descriptions* which are now too frequently mistaken for definitions. The latter are the consequence of an excess in multiplication of divisions, and would easily be avoided if it were only remembered that a difference is not a distinction, nor prolixity precision.”—*Daphne collina*: β . *neapolitana*. This plant, published as a distinct species under the latter name in Loddiges’ *Bot. Cab.*, Mr. Lindley considers as a mere variety, differing chiefly in the want of pubescence under the leaves:—a sport of Nature “which, if unmolested upon its native hills, would quickly have passed away into the type from which it sprung.”—*Spiranthes cernua*: *Ophrys* Linn., *Neottia* Willd. Mr. Lindley enumerates 16 species of *Spiranthes*, of which M. Richard, by whom the genus was established, mentions only 6. —*Rosa Kamchatica*: β . *niveus*. Some errors are pointed out in the observations of M. Trattinnick respecting this and other roses.

XXV. *Proceedings of Learned Societies.*

HORTICULTURAL SOCIETY.

July 6.—A Special General Meeting was held for the Election of a Member of the Council in the room of the late John Walker, Esq.; when Sir Claude Scott, Bart. was unanimously chosen.

The following Papers were read:

Description of an Instrument for effectually applying Tobacco Fumigation for the destruction of Insects on Trees and Plants. By Mr. John Read.

Observations on and an Account of a Collection of Seeds, formed in the neighbourhood of Constantinople, and transmitted to the Horticultural Society of London. By the Rev. Robert Walsh, LL.D., and Corresponding Member of the Society.

Description of a remarkable Elruge Nectarine Tree in the Garden of Lord Selsey at Westdean House, Sussex. By Mr. John Bowers, Gardener to Lord Selsey.

July 20.—The following Papers were read:

Description of a Peach Tree in the Garden of Miles Stapleton,

Stapleton, Esq. at Carlton, Yorkshire. By Mr. John Seymour, Gardener to Mr. Stapleton.

A Report upon the new or rare Plants which have flowered in the Society's Garden at Chiswick, from its first formation up to March 1824. By Mr. John Lindley, F.L.S. &c., Assistant Secretary for the Garden.

Aug. 3.—The following Papers were read:

On the Advantages of Coating Garden Walls with Oil Paint. By William Cotton, Esq. F.H.S.

On the Cure of Disease in Onions. By Mr. Thomas Smith.

Aug. 17.—On Artificial Climate considered with regard to Horticulture. By John Frederick Daniell, Esq., F.R.S. &c. In this highly interesting Paper, Mr. Daniell explains the whole phenomena of Radiation, and points out the best means of preventing the destruction of Plants, &c. by Frost. The artificial climate of the Hot-house is also treated of, and the errors of the usual modes of Heating fully explained.

ROYAL ACADEMY OF SCIENCES OF PARIS.

April 5.—M. Thenard, in the name of a Commission, presented a very favorable report relative to the experiments communicated by M. Sérulas, on the Cyanuret of Iodine.—The Memoir of this able chemist will be printed in the *Recueil des Savans étrangers*.—M. Cuvier read a Memoir on a new genus of Fossil Reptiles, discovered within these few years in England, and named Ichthyosaurus.—M. Frison communicated a demonstration of the Theorem of Fermat.—M. Audouart read some considerations on the origin and causes of the Yellow Fever.

April 12.—A communication was received from M. Ringler, who has invented two Machines representing the Movements of the Planets, requesting that a Commission may be appointed to examine them.—M. de Castel-Bajac requested the Academy would cause the conditions to be examined, to which it will be necessary to subject the plates of Fusible Metal, which the Government had in contemplation to adapt to the boilers of Steam-engines.—Professor Simonoff, of Kazan, presented a Memoir on the *Integral Calculus*.—M. Magendie communicated an observation which he had lately made on the effects of the lesion of the great commissure of the Cerebellum, above the passage of the fifth pair. The animal subjected to this experiment fell down on the side on which the nervous tissue was divided, and lost the agreement of motion of its eyes.—M. du Petit-Thouars read the first part of a Report which he had drawn up, in the name of a Commission, on a notice of M. Romain respecting the Anatomy
of

of Plants.—M. Poncelet, Capt. Eng., presented a manuscript work entitled A Memoir on the General Theory of Reciprocal Polarity, in continuation of his Memoir on the Centres of Mean Hermonics.—M. Magendie, for himself and M. Gay-Lussac, read a Report upon a Memoir of M. Chevreul, on several subjects of Organic Chemistry. The memoir was approved by the Academy, and will be printed in the *Recueil des Savans étrangers*.—M. Bosc made a verbal Report on a notice addressed from Moscow, by M. Fischer, relative to an Insect known in Persia by the name of *Mianah*.—M. Ampère read, for himself and M. Becquerel, a note on an experiment relative to the Nature of the Electric Current.

NATIVE CALCUTTA SOCIETY.

A Literary Society has been founded at Calcutta, by native Indians of distinction, the object of which is truly praiseworthy. It is intended to enter into discussions on all subjects connected with the progress of civilization and literature. Works of learning and general utility are to be published in English; and little manuals of morals and science, tending to impugn certain inveterate customs, and to lay down rules of reformation conducive to the well-being of individuals in Bengal. To promote these ends, mechanical and mathematical instruments, together with a chemical apparatus, are to be procured. A house is to be erected for the purpose of holding their assemblies, and containing their different collections. A College will be annexed for instruction in the arts and sciences.

XXVI. *Intelligence and Miscellaneous Articles.*

GEOLOGY OF THE GANGES AND JUMNA.

FROM a paper on this subject read before the Calcutta Medical and Physical Society on the 3d of January last, it appears that the rocks met with on the banks of these streams present examples of almost all the varieties of calcareous, argillaceous, and siliceous compounds, from the secondary concretions of calc-tuff (*kunkur*) found every where in the river's bed, to the green stone of Pointy and the primitive granite of Colgong and Juangira. Syenite and porphyritic masses are also found at some points and fragments of grey and white chalcedony. It is remarkable that no rolled or angular pieces of rock are found in the nullahs proceeding from the hills, by which the formation of the higher ranges might be determined. The neighbourhood of Monghyr is singular in presenting ridges of quartz rock that rise to a considerable

siderable height; and the old red sandstone formation is finely exemplified in the hills of Chunar and Mirzapore. The subject of geological research is comparatively new in India, and we therefore hail with feelings of real gratification any attempt to make us better acquainted with the structure of a country whose features and external configuration differ so widely from our own. We trust the Society, in its physical character, will often have to number among its contributors such zealous and able observers of nature as the author of the paper of which we have now given a slight outline. The funds of the Society, it is gratifying to remark, are in a very flourishing state, and the institution altogether has hitherto prospered beyond the most sanguine expectation of its founders.—*Ind. Gaz.*

ANALYSES BY PROF. GMELIN OF TUBINGEN.

Essonite or cinnamonstone of Ceylon: sp. gr. 3·617, at 76° Fahr.

Silica	40·006
Alumina	22·996
Lime	30·573
Peroxide of iron . . .	3·666
Potash	0·589
Volatile matter . . .	0·326
A trace of manganese	

98·156·

Pinite of St. Pardoux in Auvergne: sp. gr. 2·7575, at 47° Fahr.

Silica	55·964
Alumina	25·480
Potash	7·894
Soda	0·386
Peroxide of iron . . .	5·512
Magnesia and oxide of manganese	3·760
Water, <i>with animal matter</i> . . .	1·410

100·406

Prof. Gmelin states that this mineral, when heated in a glass phial, emits water having an empyreumatic odour, which instantly restores the blue colour to reddened litmus, and therefore contains ammonia. He thinks this alkali probably results from the decomposition of some animal matter contained in the pinite; and remarks that this mineral is never found in fresh rocks, but always, as in Auvergne, for example, in a decomposed granite, upon which the volcanic rocks of that province rest. He has also discovered a considerable proportion

tion of ammonia in the Natrolite of Hohentwiel, as well as in the Clay Porphyry in which it occurs in veins.

Prof. Gmelin determined that the pinite he examined did not contain any fluoric acid; and thinks that his analysis substantiates such an affinity, with respect to chemical composition, between pinite and mica, that they must no longer be considered as generically separate. The circumstance that pinite contains no fluoric acid, cannot be considered as an essential difference; because H. Rose has shown that those varieties of mica which occur in primitive limestone, either contain only a minute quantity of that acid, or are altogether free from it.—*Kastner's Archiv. f. d. ges. Naturlehre.* Band i. p. 221, 226.

ADULTERATION OF TEA.

To the Editors of the Philosophical Magazine and Journal.

Gentlemen,

I know not whether you may deem the following worthy of notice in your Magazine; it appears to me a curious instance of Chinese adulteration, which must upon the whole prove a considerable loss to the consumers of tea.

I have for some months observed a black sand settle at the bottom of my tea-cup, but more abundantly in the basin that receives the water first poured out of the tea-pot: upon examining it carefully a few days ago I found it to contain magnetic iron in minute crystals. The same substance was soon observed adhering to the leaves of the black tea in the caddy, sometimes in quantity sufficient to enable a magnet to raise small portions of leaves. Upon macerating some closely twisted masses, a considerable portion of sand was separated that had evidently been introduced while the leaves were fresh. It has been found in black tea of various prices.

Yours very truly,

2, Mead Place, Lambeth,
Aug. 20, 1824.

J. DE C. SOWERBY.

NEW ANALYSIS OF CAMPHOR, BY DR. GÖBEL.

The results of Dr. Göbel's analysis of this substance are as follows:

Carbon	74·67
Hydrogen	11·24
Oxygen	14·09
	<hr style="width: 10%; margin-left: auto; margin-right: 0;"/>
	100·00

According to Saussure, camphor contains a small quantity of nitrogen; whilst the analyses of Doctors Thomson and Ure agree with Dr. Göbel's in not indicating the presence of that substance.—*Schweigger's Neues Journal*, Band x. p. 356.

CONTRACTIONS PRODUCED BY HEAT IN CRYSTALS.

M. Mitscherlich has observed that the mutual inclination of the faces of Iceland spar varied in a perceptible manner by the effect of heat, and that between 0° and 100° , the change of the dihedral angles at the extremities of the axis of the rhomboid amounted to $8\frac{1}{2}'$. It thence results, that supposing no dilatation to take place perpendicular to the axis of the crystal, its cubical dilatation would still surpass that of glass, by nearly one half; but, in measuring the cubical dilatation of Iceland spar with M. Dulong, M. Mitscherlich found that it was on the contrary less than that of glass; which leads to this singular result, that though heat dilates the crystal in a direction parallel to its axis, it must cause its molecules to approach in the perpendicular directions. This M. Mitscherlich has also confirmed by measuring with a spherometer, at different temperatures, the thickness of a plate of Iceland spar cut parallel to the axis.

It is very probable that sulphate of lime would present an analogous but inverse phænomenon; namely, that the elevation of temperature would produce a perceptible contraction in the direction of its axis. (A. F.)—*Ann. de Chim.* xxvi. 222.

DIRECTION OF THE AXES OF DOUBLE REFRACTION IN CRYSTALS.

It is known that the optical axes of the crystals improperly called *crystals with two axes*, do not coincide with the axes of crystallization; but hitherto it has been regarded as a general rule, that the right lines which divide the angle contained between these optical axes into two equal parts must be equally inclined on the corresponding faces of the crystal. M. Mitscherlich has ascertained that these lines of *symmetry* with relation to the double refraction, are not always so as regards the faces of the crystal; and that in some salts, such as the sulphate of magnesia, they incline more to one side than to the other, without any defect of symmetry in the crystalline forms giving cause *a priori* to suspect such a deviation. (A. F.)—*Ann. de Chim.* vol. xxvi. p. 223.

SUPPOSED EFFECTS OF A WATER-SPOUT.

Gentlemen,

Strathinday Bleachfield, July 8, 1824.

My servants observing the particular attention I have paid to the meteorological phænomena of Loch Leven, its surrounding morass and mountains, for years back have been on the alert to bring me the earliest notice of every change, or the first appearance of any cloud, or vapour, likely to produce an indication of phænomena worth remarking.

One of them came the other morning, wearing a physiog. fraught with matter of importance, told me, he was certain we

were

were to have a year of cheapness and plenty, for the very clouds had been raining herrings on Benardy-hill. He assured me it *must* be true, for the man who told him saw the man who heard Mr. Tod's servants tell, they had gathered part of the fallen fish, and that they were not young trouts frae the Loch, but real garvey (sprats) herrings frae the sea. "See (pointing to a dark cloud) it's black in the west, wha kens but we may hae anether shower o' them ei night yet?"

In the course of the day, I fell in with an individual from the neighbourhood of Benardy, who assured me had himself gathered part of the fish, and that my friend Mr. Tod of Finnity had also gathered, and had, he believed, a few in his possession. To put the matter beyond a doubt, I dispatched a servant with a note to Mr. Tod, on whose property they had fallen, and from him I received the following very satisfactory letter:—

Dear Sir,

In reply to your note of this date respecting, *not* our draught; but our *fall* of fishes:—On Wednesday last week, my servants informed me that they had seen a quantity of small herrings lying upon the potato ground, where they had that morning been ploughing, and that they could think of no way by which they could come there, except by the heavy shower that fell the night before. Upon expressing my disbelief of this, they said if I would go to a particular spot, which was on the north of the public road, about three to four hundred yards to the west of Finnity, I should probably find some still lying. I went accordingly, and picked up eight or ten small herrings from two to two inches and a half long. I saw several more, but these were dashed by the fall. This was about eleven o'clock A. M., and the crows and sea-gulls had been very busy all morning. I examined the servants as to the quantity: they said they were lying very thick, along a tract of about fifteen to twenty yards in breadth, and one hundred in length across the potatoe ground, and as far as I can judge from their account, in a direction from south-west to north-east. I should have been very happy to have sent you a few of them, but they were so soft that they soon withered to nothing. A number of individuals saw them, and a good many were taken away.

I remain, dear sir,

Yours truly,

(Signed) W^m. Tod.

Addressed to Mr. G. Inglis.

These garveys, as they are called in this country, must have been taken up from the sea, somewhere off Culross, or Kincardine, and carried on the nearest calculation fifteen to

twenty miles. I have written to a friend at Kincardine, to inquire if there was any water-spout, or other remarkable phenomenon observed in that quarter on Tuesday evening.

Yours truly,

GAVIN INGLIS.

EXPLOSIVE ENGINE.

An engine of a very remarkable kind is, we understand, about to be brought into public notice; which, if it answer the high expectation of its inventor, may ultimately supersede the use of the steam-engine. The patents for England and Scotland are, we believe, both completed, so that we may soon expect to hear the particular details of its construction. At the lower end of a small cylinder is placed a minute apparatus for producing oil gas. As the gas is generated, it elevates a piston so as to admit as much atmospheric air as when combined with the oil gas would render the mixture explosive. When the piston has reached this height, the gas is exploded, and the mechanical force of the explosion is employed to drive machinery. Experiments have, we understand, been actually made with this power, which was employed to force up water to a considerable height.—*Brewster's New Journal.*

RIFLE ROCKETS.

In the last number of the Asiatic Journal, I observe an account (principally taken from the Calcutta John Bull) of an experiment of rockets of Capt. Parlbys manufacture, which took place on the 13th December last. I question whether it is fair to Sir W. Congreve, to call them "Capt. Parlbys rifle rockets," because their construction does not differ from the original inventor's; and the credit that Capt. Parlbys aspires to, is not, I conceive, for having made a "new discovery in the department of projectiles," but in having been able to manufacture in India, a weapon that has hitherto been procurable only in England. His proposition was submitted to the Marquis of Hastings in 1815, when Sir W. Congreve was considered as having established a claim to provide war rockets: and if since that period such pretensions be controverted, many considerations must be well weighed before English rockets be superseded by those of Indian manufacture; and I might enter into a few of them now, but that a little delay may give us the means of doing so more satisfactorily. Of twenty-four rockets with shafts, fired by Capt. Parlbys on the above occasion, six exploded, and six hit the targets (the size of which I have not seen specified). There is no doubt of his being able to make rockets that will range 3000 yards; I have
seen

seen some of Sir W. Congreve's at only 25° elevation make their first graze at two miles;) but the *extent* of range is *not* the principal point.

It is to be regretted that Capt. Parlbly thought it expedient to differ from Sir W. Congreve's mode of designating the various sizes of rockets. It would be immaterial, but the system of the latter having been established these 20 years, the innovation is attended with inconvenience: for instance, what on Sir W. Congreve's simple plan would be called a 5-pounder, is designated a 1½-pounder by Capt. Parlbly. This may accord with the "*Liber Ignium*" of Marcus Græcus; but cannot now be adopted without confusion.

Your obedient servant,

June 1824.—*Asiatic Journal*.

BAN.

To the Editors of the Philosophical Magazine and Journal.

Gentlemen,

On looking over the Meteorological Table at the end of your last number [May], I was struck on observing the great difference in the quantity of rain, which fell on or about the 15th of May at Boston, compared with that of the same period at London and Gosport. Also, the altitude of the barometer, on the 14th, at Boston was greater than at Gosport, contrary to the averages of the 30 days there registered, which is .24 of an inch less at the former place than at the latter. The quantity of rain at Boston at the time here mentioned was only $\frac{3}{4}$ ths of an inch, whereas at Gosport it was 3.64 inches, and at London 2.1 inches. If that be the case, this great and almost unprecedented fall of rain was not altogether so general as might at first be supposed, from the very great and rapid floods it produced in many parts of the country. These, together with other considerations relative to the atmospheric phænomena of that month, have induced me to trouble you with a portion of my meteorological journal of the month of May, leaving it to your judgement either to insert it, or reject it as may be thought proper.

Should others of your meteorological correspondents be inclined to communicate their journals for the same period, or if only for the first moiety of the month, they will find, on comparing these registers, something more than usually interesting, especially as to the atmospheric pressure and the fall of rain. I wish Mr. Veall would give some account of his barometer and rain-gauge, and likewise the locality of their situation.

Yours truly,

THOMAS SQUIRE.

Epping, June 7th, 1824.

1824. D.M.	8 A.M.										2 P.M.										Weather.
	Barom.	State of Barom.	Attached Therm.	External Therm.	De Luc's Therm.	Wind. N. E. S.	State of Wind.	Barom.	State of Barom.	Attached Therm.	External Therm.	De Luc's Therm.	Wind. N. E. S. W.	State of Wind.	Depth of Rain.	Evaporation					
May 9	30.01	R.	56	56	71	4	VL	29.96	S.	57	64	66	3	1	L		Fair and bright.				
10	29.73	S.	55	55	66	2	VL	29.69	S.	59	68	54	4		L		Fair and bright.				
11	29.66	St.	54	50	69	4	B	29.66	St.	53	55	64	4		RB		Fair, cloudy.				
12	29.57	St.	49	46	69	4	L	29.57	St.	49	53	63	3		L		Fair, cloudy.				
13	29.53	St.	48	44	69	3	VL	29.47	S.	48	50	66	3		L		Cloudy, some rain at times.				
14	29.22	S.	45	44	92	3	RB	29.22	St.	48	46	82	2		RB		Rain.				
15	29.17	S.	45	43	95	3	RB	29.17	St.	47	43	96	3	1	L		Much rain.				
16	29.38	R.	45	43	89	4	RB	29.52	R.	48	52	64	4		RB		Some rain a.m., afternoon fair.				
17	29.68	St.	45	44	64		L	29.44	S.	48	55	55			L		Fair.				
18	29.59	St.	49	50	66	1	RB	29.57	S.	50	54	61	4		L		Fair, evening some rain.				
19	29.49	R.	50	47	79	4	VL	29.48	St.	50	54	61	2		L		Fair, cold and cloudy.				
20	29.38	St.	48	46	64	2	RB	29.41	R.	49	56	54	2		RB		Cold and stormy.				
21	29.54	R.	47	44	63	3	RB	29.55	St.	50	56	54	3	1	L		Frosty morn ^g , mostly bright.				
22	29.62	R.	47	45	68	2	L	29.62	St.	49	56	51	2		L		Fair, cold.				
23	29.60	S.	48	47	67	3	VL	29.57	S.	50	58	56	4		VL		Fair and bright.				
24	29.58	R.	51	51	80	4	VL	29.61	R.	52	53	79	3	1	VL		Cloudy, a gentle rain.				
25	29.81	R.	49	48	71	3	VL	29.84	R.	52	59	63	4		VL		Fair, cloudy.				
26	30.05	R.	52	55	74	4	VL	30.12	R.	56	66	59	4		VL		Fair and warm.				

*Calendar of Flora, Fauna, and Pomona, at Hartfield in Sussex,
from July 19 to August 13.*

July 19.—Fine warm summer weather seems at length set in, the thermometer averaging about 72° at its maximum, and 58° at its minimum. The solstitial plants in general are in full flower, having opened somewhat later than usual this year, and the æstival Flora has already begun to display her gay wardrobe. Of the solstitial plants, the Scarlet Lychnis, the abundance of Pinks, Roses, Campions, the Canterbury Bells, and the numerous Poppies, may afford an example; in no preceding year have they flowered more luxuriantly, with the sole exception of *Papaver somniferum*. Of the æstival plants the Scabious, the Indian Cress, and various Campanulas, may be noticed as very abundant. The China Aster and other tender annuals have been destroyed this season by the abundant ants and other destructive vermin; and I have only succeeded in raising a few seeds already young. *Inula Helenum* in full blow.

July 20.—St. Margaret. The White Lily and the *Campanula rapunculoides* in full blow. The Elecampane also in flower.

July 21.—*Convolvulus sepium* in blow in the hedges.—Tonight about a quarter past 10 P.M. we noticed a remarkable red light in the clouds to the north, passing gently over from the east; the whole substance of the flimsy *cumuli* seemed illuminated with a reddish light. The phænomenon only lasted 10 minutes, and was probably some peculiar reflection of light refracted in the atmosphere to the northward and proceeding from the sun, who, though set to us, might illuminate the higher atmosphere.

July 22.—St. Magdalen*. *Campanula Rapunculus*, *C. Trachelium*, and several others, in full blow at Walthamstow.

July 24.—*Chironia Centaureum* in flower.

July 25.—The *Circæa alpina*, which flowered in June, still flowers in abundance, and also a large variety of it two feet high, which approximates much to *Circæa lutetiana*.

July 26.—After various signs of rain deduced from animals, from the sky, and from aches and pains, which prevailed during the last two or three days of the fine weather, a copious watering from the north has set in this afternoon.

July 27.—Cooler after the rain; breeze from the north.

July 28.—Wind S.W. and fair summer day. *Sonchus pa-*

* I shall always notice the remarkable days of the calendar in this Journal, because reference is made to them in the old Botanical Calendars (see Perennial Calendar, July 23, in which this is explained).

lustris flowers in my garden. The Scarlet Lychnis and Sweet William begin to decline, and Roses cast their petals in abundance on the ground: I have observed that ants of all kinds are very numerous and destructive in the garden this year. Earwigs are less plentiful than usual. Slugs and snails very abundant. *Convolvulus sepium* and *C. arvensis* very abundant.

August 2.—*Boletus bovinus* grows in the orchard. There are now growing in my field a great quantity of *Agarici*, which form a sort of semicircle in which the grass grows richer than ordinary, and looks like what is called a Fairy Ring.

August 6.—*Convolvulus tricolor* flowering at Edenbridge.

August 7.—*Althæa rosea* in full flower in several varieties, crimson, rose-colour, and yellow.

August 9.—Small meteor seen; these phænomena abound particularly in August.

August 10.—Much sondercloud early: warm day, with clouds at night.

August 11.—Beautiful crimson sonderclouds and waneclouds at sunset.

The *Pomona* is backward; plums begin to ripen, and together with apricots are very few in number. Raspberries and strawberries are nearly gone. Currants were late this year, but decline early, and ripen very badly. The wheat, oats, and all kinds of grain are very late; nor has the harvest yet commenced here, not a single field being cut yet. The bat seen flitting about tonight till very late.

August 12.—Fungi begin to appear. *Agaricus integer* already grown in three varieties, the gray, the brown, and the crimson. *Agaricus aurantius* is also plentiful, as are *Boletus luteus* and *B. bovinus*.

August 13.—I ascertained today, as I have on several occasions lately, that the direction of the wind above, even only 300 or 400 feet from the ground, differs from the wind immediately blowing over the surface of the earth. By tying a kite to the back of another when 300 feet of string were out, and then letting the second or lower kite have about 600 feet of string, I caused the upper one to ascend very high, and it got a direction somewhat different from the lower one, the former indicating a wind from S.S.W., the latter W.S.W. and sometimes S.W. according to the height; so that I conceive the wind fluctuated gradually according to the altitude, or else blew in a sort of ascending spiral. Kites thus attached to each other will ascend to a prodigious height, and may become good indicators of wind. Seven or eight may be flown alternately 300 feet above each other.

Hartfield, Aug. 13, 1824.

T. FORSTER.

LIST OF NEW PATENTS:

To Charles Random Baron De Berenge, of Target Cottage, Kentish Town, in the parish of St. Pancras, Middlesex, for his improvement as to a new method or methods of applying percussion to the purpose of igniting charges in fire-arms generally, and in a novel and peculiar manner, whereby a reduction of the present high price of fire-arms can be effected, and the priming is also effectually protected against the influence of rain or other moisture; such invention and contrivances rendering the percussion principle more generally applicable even to common pistols, blunderbusses and muskets, as well as to all sorts of sporting and other guns, by greatly reducing not only the charges of their manufacture, but also those impeding circumstances which persons have to encounter whilst loading or discharging fire-arms when in darkness, or whilst exposed to wet, or during rapid progress—serious impediments which soldiers and sailors, and consequently the service, more particularly and most injuriously experience.—Dated 27th July 1824.—2 months allowed to enrol specification.

To Alexander Nesbitt, of Upper Thames-street, London, broker, who, in consequence of a communication made to him by William Van Houten the younger, a foreigner residing abroad, is in possession of a process by which certain materials may be manufactured into paper or felt, or a substance nearly resembling coarse paper or felt, which material so prepared is applicable to various useful purposes.—27th July.—6 months.

To Thomas Wolrich Stansfeld, of Leeds, Yorkshire, merchant, for certain improvements in power looms and the preparation of warps for the same.—27th July.—6 months.

To Edward Cartwright, of Brewer-street, Golden-square, in the parish of St. James, Westminster, Middlesex, engraver and printer, for his improvements on or additions to roller printing presses.—27th July.—2 months.

To Charles Jefferies, of Havanah Mills near Congleton, silk thrower, and Edward Drakeford, of Congleton, watch-maker, both in the county of Chester, for their method of making a swift and other apparatus thereto belonging, for the purpose of winding silk and other fibrous materials.—29th July.—2 months.

To William Wheatstone, of No. 118, Jernyn-street, St. James's, Middlesex, music-seller, for his method of improving and augmenting the tones of piano-fortes, organs, and euphonons.—29th July.—2 months.

To John Price, of Stroud, Gloucestershire, engineer, for certain improvements in the construction of spinning machines.—5th August.—6 months.

To George Graydon, of Bath, esquire, a captain in our Royal Engineers, for his compass for navigation and other purposes.—5th August.—6 months.

To William Johnson, of Great Tothan, Essex, gentleman, for a means of evaporating fluids, for the purpose of conveying heat into buildings for manufacturing, horticultural, and domestic uses, and for heating liquors in distilling, brewing, and dyeing, and in making sugar and salt with reduced expenditure of fuel.—5th August.—4 months.

To Jacob Perkins, of Fleet-street, London, engineer, for certain improvements in propelling vessels.—9th August.—6 months.

To John Fassell, of Mells, Somersetshire, edge-tool maker, for his improved method of heating woollen cloth for the purpose of giving it a lustre in dressing.—11th August.—2 months.

To Herman Schroder, of Hackney, Middlesex, broker, for his new filter.—11th August.—6 months.

A METEOROLOGICAL TABLE: comprising the Observations of Dr. BURNET at Gosport, Mr. CARY in London, and Mr. VALL at Boston.

Days of Month, 1824.	Gosport, at half-past Eight o' Clock, A.M.				Clouds.					Height of Barometer, in Inches, &c.		Thermometer.			RAIN.		WEATHER.						
	Barom. in Inches, &c.	Thermo.	Temp. of Sp. Water.	Hygrom.	Wind.	Evaporation.	Rain near the Ground.	Cirrus.	Circum.	Cirrostr.	Stratus.	Cumulus.	Cumulost.	Nimbus.	Lond.	Bost.	Lond.	Bost.	Lond.	Bost.			
																					8 A.M.	Noon.	1 P.M.
July 26	29.89	69	51.00	50	E.	...	0.715	...	1	1	1	1	1	29.90	29.50	66.70	52	Fine		
27	30.00	58	...	67	N.	1	1	1	1	1	1	30.16	29.70	55.66	58	Cloudy, shower p.m.		
28	30.33	62	...	55	SW.	0.40	...	1	1	1	1	1	1	30.32	29.87	59.74	61	Fine, Th. 3 p.m. 73.5		
29	30.14	63	...	50	E.	1	1	1	1	1	1	30.10	29.70	60.70	55	Do. Th. 3 1/2 p.m. 74.5		
30	29.72	60	...	54	E.020	1	1	1	1	1	1	29.72	29.30	55.67	55	Fine [night]		
31	29.73	65	51.40	54	E.	.48	.850	1	1	1	1	1	1	29.77	29.35	54.67	60	Cloudy, rain at night		
August 1	29.65	59	82	...	E.400	1	1	1	1	1	1	29.80	29.40	59.61	54	0.25	Cloudy
2	30.10	64	...	53	S.	1	1	1	1	1	1	30.15	29.55	54.67	60	0.25	Rain
3	30.04	66	...	55	S.	.35	.380	1	1	1	1	1	1	30.11	29.64	61.70	61	Fine, rain at night
4	29.94	65	...	56	NW.015	1	1	1	1	1	1	29.90	29.50	61.69	61	Cloudy, do.
5	29.80	63	...	54	NW.150	1	1	1	1	1	1	29.83	29.30	60.68	60	Cloudy, do.
6	29.70	61	...	57	W.	.40	.315	1	1	1	1	1	1	29.75	29.27	60.65	58	Cloudy, rain p.m.
7	29.90	60	51.60	64	N.045	1	1	1	1	1	1	29.96	29.50	58.64	60	Cloudy
8	29.97	61	...	66	SW.025	1	1	1	1	1	1	29.91	29.50	61.64	60	0.37	Cloudy, rain a.m.
9	29.80	67	...	67	SW.	.30	...	1	1	1	1	1	1	29.80	29.27	65.71	56	Fine, rain a.m.
10	29.95	62	...	63	SW.140	1	1	1	1	1	1	29.95	29.52	60.70	66	Fine
11	29.77	66	...	68	SW.010	1	1	1	1	1	1	29.82	29.26	66.71	62	Fine
12	29.86	67	...	62	W.	.40	...	1	1	1	1	1	1	29.86	29.38	66.70	57	Fine
13	29.92	66	...	60	SW.010	1	1	1	1	1	1	29.93	29.50	66.65	55	Fine
14	30.07	61	52.00	60	NW.035	1	1	1	1	1	1	30.07	29.60	55.66	56	Fine
15	29.82	61	...	70	SW.	.40	.550	...	1	1	1	1	1	29.70	29.30	60.63	55	Fine, rain at night
16	29.82	58	...	70	W.140	1	1	1	1	1	1	29.84	29.30	57.67	60	Fine
17	29.87	62	...	65	S.045	1	1	1	1	1	1	29.77	29.57	61.65	60	Cloudy
18	29.76	61	...	62	SW.	.45	.260	1	1	1	1	1	1	29.68	29.23	60.64	50	Fine, rain p.m.
19	29.87	60	...	60	W.460	1	1	1	1	1	1	29.89	29.35	55.65	59	Fine
20	29.89	65	52.20	67	W.275	1	1	1	1	1	1	29.92	29.50	60.65	61	Fine
21	29.86	65	...	66	SW.	.55	.035	1	1	1	1	1	1	30.10	29.70	58.58	51	Cloudy
22	30.04	59	...	55	N.	1	1	1	1	1	1	30.19	29.85	54.68	50	Fine, rain a.m.
23	30.15	56	...	60	N.	1	1	1	1	1	1	30.27	29.90	51.68	58	Fine
24	30.24	61	...	62	N.	1	1	1	1	1	1	30.37	29.95	55.70	61	Cloudy
25	30.35	61	52.20	60	N.	.55	...	1	1	1	1	1	1	30.38	29.95	55.70	61	Cloudy
Averages:	29.934	62.39	51.73	61.1		4.28	5.015	22.19	31	...	26.22	22	22	29.36	29.50	2.60	...	2.01	

THE
PHILOSOPHICAL MAGAZINE
AND JOURNAL.

30th S E P T E M B E R 1824.

XXVII. *Remarks on the Experiments of the Pendulum made by Captain KATER, M. BIOT, &c. By WILLIAM GALBRAITH, Esq. A.M.*

THE determination of the figure and magnitude of the earth has long formed to the philosopher an interesting object of research. The attempts of the ancients were very rude and inaccurate; but still they kept alive that spirit of successive improvement by which each observer endeavoured to surpass his immediate predecessor, both in the accuracy of his instruments and the exactness of his results, till in our times it would appear that a very high degree of precision has been attained.

This is sufficiently established by the extensive systems of operations lately performed in this country, and in France and Spain; by which the Shetland and Balearic Isles have been connected by actual mensuration, comprehending an arc of $22^{\circ} 5' 29''$ of latitude. In the execution of this survey, the British on their part have employed the largest and most accurate instruments ever constructed; by this means cutting off all those sources of inaccuracy not essentially involved in the nature of the question: while the French have used instruments of small dimensions, but of great ingenuity, correcting the errors to which they are thus liable, by ingenious expedients and appropriate formulæ.

In the prosecution of the survey, too, the length of the pendulum oscillating seconds at the more important stations, has been deemed an object worthy of being attained, in order to promote the objects of science by unfolding the laws that regulate the structure and figure of the earth; and the instruments and methods employed by the men of science engaged, were as characteristic of the genius and habits of the two nations in this case as in the former.

Captain Kater, by selecting a particular property of the pendulum, or of an oscillating body, was enabled to dispense with formulæ necessarily employed by Borda and Biot, by that means avoiding the *possibility* of error to which the methods

thods of the latter *may* be liable, going upon the generally received principle, that to remove all sources of error, however minute, is preferable to trusting to their correction.

We believe that the results obtained by the French philosophers merit great confidence, from the ingenious devices to which they, in their researches on the determination of the length of the pendulum, had recourse; though we cannot help thinking that the method of Captain Kater, generally speaking, is, both on account of its simplicity and accuracy, justly to be preferred. If Captain Kater's apparatus, which may still perhaps be susceptible of improvement, be more delicate than that used by M. Biot, from the irregularities in the density of the materials constituting the exterior crust of the earth, its results may be expected, in particular cases, to be less consistent with each other, and with the generally received theory of the oblateness of the spheroidal figure of the earth.

When however observations are made on a considerable number of points in an extensive arc of the meridian, it may be naturally expected that these small irregularities will tend to correct one another, so that an excess in one direction may be very nearly counterbalanced by a defect in another, and that a mean of the whole being properly obtained, will be very near the truth. For this purpose we have applied the method of *minimum squares* to the experiments of Kater and Biot, as best calculated to give a true mean result.

It is demonstrated by the theory of attraction that the length of the pendulum is augmented from the equator to the pole proportionally to the square of the sine of the latitude, in such a manner that, if the length of the pendulum at the equator is represented by z , and its absolute variation from the equator to the pole by y , l , its length in any other latitude λ , will be represented by the following equation:

$$l = z + y \sin^2 \lambda \quad (1)$$

If we have two equations of this form, in which l and λ are determined by observation, we can obtain the values of z and y ,

$$\begin{aligned} l &= z + y \sin^2 \lambda \\ l' &= z + y \sin^2 \lambda' \\ l' - l &= y \sin^2 \lambda' - y \sin^2 \lambda = y (\sin^2 \lambda' - \sin^2 \lambda). \end{aligned}$$

$$\text{Hence } y = \frac{l' - l}{\sin(\lambda' + \lambda) \sin(\lambda' - \lambda)} \quad (2)$$

$$\text{and } z = l - y \sin^2 \lambda \quad (3)$$

At the equator $\lambda=0$, and therefore $l=z$ as already observed; consequently $\frac{y}{z}$ expresses the diminution of gravity from the pole to the equator.

Now,

Now, by the doctrine of central forces, if ϕ denote the centrifugal force; π the circumference of a circle to diameter unity; r the radius of the given circle in which a body revolves; t the time of revolution, and g the gravitating force; then $\phi = \frac{4\pi^2 r}{g t^2}$. But by the theory of the pendulum, if l is its length, $g = \pi^2 l$; hence by substitution

$$\phi = \frac{4r}{t^2 l} = \frac{r}{\left(\frac{t}{2}\right)^2 l} \quad (4)$$

The ratio of the centrifugal force to gravity may be expressed by $\frac{\phi}{1+\phi}$ (5)

The ellipticity or flattening of the earth is from theory equal to $\frac{5}{2}$ of the ratio of the centrifugal force to gravity, diminished by the fraction obtained from dividing the difference of the lengths of the pendulum at the pole and equator by its length at the equator*. Wherefore if ϵ denote the ellipticity, we obtain

$$\epsilon = \frac{5}{2} \times \frac{\phi}{1+\phi} - \frac{y}{z} \quad (6)$$

But by substituting the value of ϕ from equation (4)

$$\epsilon = \frac{5}{2} \times \frac{r}{r + \left(\frac{t}{2}\right)^2 l} - \frac{y}{z} \quad (7)$$

As t in our investigations denotes the time the earth takes to perform a rotation about its axis, and is found to be $23^h 56^m 4^s \cdot 0908 = 86164^s \cdot 0908$; consequently $\frac{1}{2}t = 43082^s \cdot 0454$, and $\left(\frac{t}{2}\right)^2 = 1856062635$ nearly, whence

$$\epsilon = \frac{5}{2} \times \frac{r}{r + 1856062635 l} - \frac{y}{z} \quad (8)$$

Since r is the radius of the equator in this case, l the length of the pendulum there, and y the excess of the length of the pendulum at the pole above that at the equator, we must ascertain the values of these quantities before the ellipticity can be obtained.

Playfair in his *Outlines of Natural Philosophy*, vol. ii. gives for the radius of the equator about 20921153 feet; and Col. Lambton in the *Philosophical Transactions* for 1818 gives 60848 fathoms, or 365088 feet, for a degree on the equator. The radius is therefore $= \frac{365088 \times 360}{6 \cdot 2831858} = 2091800$ feet. A mean between this and Playfair's is 20919576 feet, which may be

* *Mécanique Céleste*, liv. iii. § 34.

considered as a very close approximation to the truth. If this is substituted in equation (8), it becomes

$$\varepsilon = \frac{5}{2} \times \frac{20919576}{20919576 + 1856062635z} - \frac{y}{z} \quad (9)$$

Consequently it is now only necessary to determine y and z , by means of equations (2) and (3) from the best observations on the pendulum, to obtain ε .

In the *Philosophical Transactions* for 1819, Captain Kater gives the following series of experiments on the pendulum:

Places.	Latitude.	Length in Sir George Shuckburgh's Scale.
		Inches.
1. Unst	60° 45' 28" N.	39·17146
2. Portsoy	57 40 59	39·16159
3. Leith	55 58 41	39·15554
4. Clifton	53 27 43	39·14600
5. Arbury	52 12 55	39·14250
6. London	51 31 8	39·13929
7. Shanklin	50 37 24	39·13614

If in formula (1) we substitute the values $\sin^2 \lambda$, it will give the length of the pendulum at each place where the experiments have been made, when y and z are known. In designating by $e_1, e_2, e_3, \&c.$ the differences between the lengths observed and calculated by the formula, we shall obtain the following equations of condition:

1. $39\cdot17146 - z - 0\cdot7613650 y = e_1$
2. $39\cdot16159 - z - 0\cdot7142003 y = e_2$
3. $39\cdot15554 - z - 0\cdot6869483 y = e_3$
4. $39\cdot14600 - z - 0\cdot6455504 y = e_4$
5. $39\cdot14250 - z - 0\cdot6246030 y = e_5$
6. $39\cdot13929 - z - 0\cdot6127966 y = e_6$
7. $39\cdot13614 - z - 0\cdot5975166 y = e_7$

Now, to determine the values of y and z by the method of minimum squares, that is, in such a manner that the sum of the squares of the errors $e_1, e_2, e_3, \&c.$ may be the smallest possible, it is necessary to form the equations of minimum

* If a mean of Kater's, Biot's, Sabine's, and Goldingham's measures be taken, $\varepsilon = 0\cdot008638 - \frac{y}{z}$, a very simple expression, though in our determination we have preferred the values of y and z deduced immediately from the observations.

with

with relation to y and to z . Since the coefficient of z is unity in all the preceding equations, the condition of the minimum with regard to that unknown quantity will be given by making their sum equal to zero; thus

$$274.05252 - 7z - 4.6429802y = 0 \quad (10)$$

This equation of the minimum can only take place in so far as the sum of the errors shall be nothing. The new condition that it expresses, and which the errors ought to satisfy, holds not with regard to the method of least squares, but to the particular form of the equations above.

If we multiply each equation of condition by the coefficient of y in that equation, we shall have the following results:

$$\begin{aligned} 29.8237787 - 0.7613650z - 0.5796767y, \\ 27.9692193 - 0.7142003z - 0.5100820y, \\ 26.8978315 - 0.6869483z - 0.4718980y, \\ 25.2707160 - 0.6455504z - 0.4167354y, \\ 24.4485230 - 0.6246030z - 0.3901290y, \\ 23.9844238 - 0.6127966z - 0.3755198y, \\ 23.3844933 - 0.5975161z - 0.3570262y. \end{aligned}$$

The sum of all these quantities equalled to zero will give

$$181.7789856 - 4.6429802z - 3.1010671y = 0 \quad (11)$$

From equation (10) we get $z = 39.15036 - 0.6632829y$, and from equation (11) $z = 39.1513592 - 0.6679045y$. Equalling these two values of z , we get $y = 0.2162022$. Hence $z = 39.0069568 =$ the length of the seconds' pendulum at the equator, and $39^{\text{in}}.0069568 + 0.2162022 = 39^{\text{in}}.2231590 =$ the length of the pendulum at the pole. If in equation (1) we substitute the values of y and z determined above, we shall have

$$l = 39.0069568 + 0.2162022 \sin^2 \lambda \quad (12)$$

from which we are enabled to find the length of the pendulum by computation.

	Length of the Pendulum		Differences.
	by Experiment.	by Calculation.	
	inches.	inches.	inches.
1. Unst	39.17146	39.171566	$e_1 + 0.000106$
2. Portsoy	39.16159	39.161368	$e_2 - 0.000222$
3. Leith	39.15554	39.155477	$e_3 - 0.000063$
4. Clifton	39.14600	39.146526	$e_4 + 0.000526$
5. Arbury	39.14250	39.141997	$e_5 - 0.000503$
6. London	39.13929	39.139445	$e_6 + 0.000155$
7. Shanklin	39.13614	39.136141	$e_7 + 0.000001$

The sign + denotes that the value by computation is greater than that by experiment, - less.

Here we find, by inspecting the column of differences, that the greatest errors fall on the lengths of the pendulum at Clifton and Arbury Hill. At the latter place the length by experiment being greater than that by computation, shows that the gravitating force is increased by some irregularity in the structure of the earth's surface, and thus speaking the same language that the zenith sector of Mudge did about twenty years ago. The contrary takes place at Clifton. At Shanklin Beacon the error is almost nothing; it is very small at Leith; and at Unst, London, and Portsoy, it is but inconsiderable, differing only about one or two *ten thousandth parts of an inch*.

Returning now to equation (9), since we have found the values of y and z we have

$$\epsilon = \frac{5}{2} \times \frac{20919576}{20919576 + 1856062635 \times 3^{.2505779}} - \frac{y}{z}, \text{ or,}$$

$$\epsilon = 0.0086386 - \frac{y}{z} = 0.0086386 - 0.0055435 = 0.0030951,$$

or $\frac{1}{323.1}$ nearly. This value, being derived by the principles of minimum squares from the totality of the observations made by Capt. Kater between Unst and Dunnose, will, as truly as the observations can be depended upon, represent the ellipticity of the meridian passing nearly through these points. If we compare Unst and Dunnose together, which are the extremities of the series differing by $10^{\circ} 8' 4''$ of latitude, we should get $l = 39.007336 + 0.215565 \sin^2 \lambda$, and $\epsilon = 0.003113 = \frac{1}{321.2}$, a compression nearly the same as that derived from the mean of the whole, though rather greater.

We shall now treat the experiments made by M. Biot in the same manner.

Places.	North Latitude.	Decimal Pendulum in Millimetres.	Sexagesimal Pendulum in English Inches.
1. Formentera	$38^{\circ} 39' 56''$ N.	741.25200	39.094187
2. Figeac	44 36 45	741.61228	39.113189
3. Bordeaux	44 50 26	741.60872	39.113002
4. Clermont	45 46 48	741.70518	39.118088
5. Paris	48 50 14	741.91749	39.129285
6. Dunkirk	51 2 10	742.07703	39.137700
7. Leith	55 58 37	742.41343	39.155442
8. Unst	60 45 25	742.723136	39.171776

Following

Following here the method pursued at page 164-5:

1. $39\cdot094187 - z - 0\cdot3903417 y = e_1$
2. $39\cdot113189 - z - 0\cdot4932370 y = e_2$
3. $39\cdot113002 - z - 0\cdot4972172 y = e_3$
4. $39\cdot118088 - z - 0\cdot5136117 y = e_4$
5. $39\cdot129285 - z - 0\cdot5667720 y = e_5$
6. $39\cdot137700 - z - 0\cdot6045723 y = e_6$
7. $39\cdot155442 - z - 0\cdot6869300 y = e_7$
8. $39\cdot171776 - z - 0\cdot7613523 y = e_8$

From which is obtained $z = 39\cdot129084 - 0\cdot5642543 y$.

Again,

1. $15\cdot2600913 - 0\cdot3903417 z - 0\cdot1523666 y$
2. $19\cdot2920719 - 0\cdot4932370 z - 0\cdot2432826 y$
3. $19\cdot4476573 - 0\cdot4972172 z - 0\cdot2472249 y$
4. $20\cdot0915076 - 0\cdot5136117 z - 0\cdot2637970 y$
5. $22\cdot1773831 - 0\cdot5667720 z - 0\cdot3212304 y$
6. $23\cdot6615693 - 0\cdot6045723 z - 0\cdot3655077 y$
7. $26\cdot8970478 - 0\cdot6869300 z - 0\cdot4718729 y$
8. $29\cdot8235217 - 0\cdot7613523 z - 0\cdot5796577 y$

From these we obtain $z = 39\cdot133698 - 0\cdot585937 y$.

Equating this and the preceding value of z , and we have $39\cdot129084 - 0\cdot5642543 y = 39\cdot133698 - 0\cdot585937 y$, from which it follows that $y = 0\cdot212796$, and hence $z = 39\cdot133698 - 0\cdot124684 = 39\cdot009014 =$ the length of the pendulum at the equator, and $39\cdot009014 + 0\cdot212796 = 39\cdot22181 =$ the length of the pendulum at the pole.

These determinations differ at the equator by $0\cdot00206$ in., and at the pole by $0\cdot00135$ in. only, from those of Capt Kater. Whence $l = 39\cdot009014 + 0\cdot212796 \sin^2 \lambda$.

By substituting for $\sin^2 \lambda$ their proper values at the different points of observation, we shall have the lengths of the pendulum by computation, which compared with those from experiment give the differences denoted by $e_1, e_2, e_3, \&c.$

Places.	Length of the Pendulum by		Errors.
	Experiment.	Calculation.	
	Inches.	Inches.	
1. Formentera	39·094187	39·092077	$e_1 - 0\cdot002110$
2. Figeac	39·113189	39·113973	$e_2 + 0\cdot000784$
3. Bordeaux	39·113002	39·114820	$e_3 + 0\cdot001818$
4. Clermont	39·118088	39·118309	$e_4 + 0\cdot000221$
5. Paris	39·129285	39·129621	$e_5 + 0\cdot000336$
6. Dunkirk	39·137700	39·137665	$e_6 - 0\cdot000035$
7. Leith	39·155442	39·155190	$e_7 - 0\cdot000252$
8. Unst	39·171776	39·171027	$e_8 - 0\cdot000749$

Again,

Again, from these errors we see that the greatest deviation takes place at Formentera, and the next at Bordeaux with contrary signs. Indeed the length of the pendulum by experiment diminishes from Figeac to Bordeaux; whereas, since the latitude of Bordeaux is greater than that of Figeac, it ought to increase. Perhaps since the difference of latitude between these places is so small, being only $13' 41''$, the local irregularities and small unavoidable errors of observation may be sufficient to account for this. Indeed it appears to be precisely of such a nature as that which occurred to the late General Mudge in the measurement of an arc of the meridian, as well as Capt. Kater at Arbury Hill; and in either case it would be unfair to impute it totally to errors on the part of the observers or their instruments.

The compression may now be determined by means of equation (9), thus:

$$\varepsilon = \frac{5}{2} \times \frac{20919576}{20919576 + 1856062635 \times 3 \cdot 250751} - \frac{0 \cdot 212796}{39 \cdot 009014},$$

$$\varepsilon = 0 \cdot 008638 - 0 \cdot 005455 = 0 \cdot 003183 = \frac{1}{314 \cdot 2}.$$

This compression is somewhat greater than that determined from the experiments of Capt. Kater, which was $\frac{1}{323 \cdot 1}$.

The compression resulting from a comparison of the lengths of the pendulum at the extremities of the arcs, namely, at Unst and Formentera, is $\frac{1}{305}$, or a little greater than $\frac{1}{314}$.

This also occurred when we examined the experiments of Capt. Kater.

Two more experiments* have been made which deserve to be examined, namely, that made by Capt. Sabine at Melville Island in latitude $74^{\circ} 47' 12''$ N., and that at Madras by Mr. Goldingham in latitude $13^{\circ} 4' 9''$ N. The length of the pendulum at the former place was ascertained to be

39·207000 inches

at the latter

39·023380

from which we obtain $z = 39 \cdot 012710$, $y = 0 \cdot 208658$,

and $\varepsilon = 0 \cdot 0086372 - 0 \cdot 0053485 = 0 \cdot 0032887 = \frac{1}{304 \cdot 1}$.

On considering the results that have been obtained from all these experiments, it appears that the mean compression derived from all the experiments in each series of observations, is smaller than that deduced from those made at the extremity

* The writer of this paper had not got the observations of Capt. Hall, Mr. Foster, &c. at the time it was written. These will form another communication.

of each arc. Thus Capt. Kater's experiments give on the whole $\frac{1}{323}$; while the extremes give $\frac{1}{321}$, or a little more than the preceding. Again, M. Biot's give for the whole $\frac{1}{314}$, and for the extremities $\frac{1}{305}$ somewhat greater. Mr. Goldingham's compared with Capt. Sabine's $\frac{1}{304}$, greater than the mean of Kater and Biot, but little more than Biot's extremes. Whence we may infer that the compression derived from the length of the pendulum at distant latitudes, does not correspond with that inferred from measurements made at intermediate points. This, therefore, leads to the conclusion that the earth is not regular either in its structure, or its figure, or in both.

The compression, so far as these experiments can be depended upon, appears to be LESS when derived from measures of the pendulum taken at about the latitude of 45° N. than when deduced from measures obtained at higher and lower latitudes combined. This is the more remarkable, as from the measurement of arcs the *contrary* takes place, namely, that by the comparison of arcs not far distant from 45° N., the compression is *greater* than when those at high and low latitudes are compared. It is shown by Delambre that the compression for the arc passing through France, and nearly bisected by the parallel of 45° , is $\frac{1}{148}$, about double of that derived from the pendulum; while the comparison of distant arcs, as those of Col. Lambton and Mr. Swanberg, from which the Colonel finds a compression of $\frac{1}{310}$, not differing much from that derived from the pendulum in latitudes considerably distant.

It is hence evident, that no mean result will correspond to all places on the earth's surface; and as such *curious anomalies*, which, so far as we know, are noticed here for the first time, occur in the determination of the value of the same quantity when these different methods are employed, no one quadrantal arc of the meridian, it is probable, will correspond exactly with another, and the *metre*, the ten millionth part of this arc, which the French have adopted as their standard unit of measures, has no advantage over any other conventional standard well ascertained.

It is also quite clear that we can only arrive at the true figure and structure of this globe from the measurements of many arcs in almost all latitudes and longitudes practicable, accompanied with corresponding experiments on the length of the pendulum. The number of operations of this kind is

constantly increasing under the patronage of the most liberal Governments of Europe, and particularly of our own.

We have been informed that Capt. Sabine has been lately determining the length of the pendulum at various places on the earth's surface; which, from their accuracy and importance, cannot fail to be highly interesting in the inquiry to which we have now been directing our attention.

Edinburgh, July 18, 1823.

XXVIII. *Introduction to the Seventh Section of BESSEL'S Astronomical Observations.*

[Continued from p. 109.]

4. *Flexure of the Telescope.*

THE effect of this flexure on the readings of the circle has been determined by two methods: the first is founded on a comparison of the zenith distances of α *Ursæ Minoris* obtained by reversing the instrument with those observed by reflexion from the surface of water; the second seems to be still more sure and advantageous, being deduced from a comparison of the distances of northern and southern stars measured both by direct vision and by reflexion, and therefore independent of the reversion of the instrument. Both methods are independent of the divisions of the instrument; the one position of the instrument being in the same relation to the zenith as the other to the nadir; so that the direct observations in the one position, and those obtained by reflexion in the other, depend on divisions of the circle which are 180° distant from one another; and consequently are in both cases the same, the verniers being likewise diametrically opposite one another. In order, therefore, to eliminate the possible errors of division, it will be proper to compare the direct observations in one position of the instrument with those obtained by reflexion in the other.

These observations have some difficulty, because the slightest draught of air will disturb the level of the water, and many are therefore lost; they rarely succeed when the wind is from the side of the star that is to be observed; and consequently the distances of northern and southern stars are rarely obtained by reflexion from water on the same day. This difficulty may be avoided by measuring the distances of the reflected images of stars from a fixed point in the heavens, and by deducing the distances of the stars from the sums of such observed distances.

The fixed point which I have used, not only in these but likewise

likewise in all other investigations which are founded on observations with the circle, is the pole as determined by the mean of the upper and lower passages of α and δ *Ursæ Minoris*. This fixed point I have always endeavoured to obtain with such a degree of accuracy that I never reversed the instrument before its determination had the weight of 30 observations, five of which were usually made at each passage. I have thought such a large number requisite, in order that the uncertainty which they leave might not too *unequally* increase the uncertainty of every single observation of a star in the different periods between two reversions, even when there are considerably more than 30 observations in one period. This arrangement of the observations allows, indeed, to assign an equal value to every measured distance of a star from the fixed point, as the inequality, which strictly taken still remains, thereby becomes inconsiderable; it would besides not be easy correctly to estimate it, as it undoubtedly does not depend on the number of observations only. I have therefore used the two polar stars only as the means of ensuring the same point of comparison, not caring whether that point be the true pole or not: the admission of other more distant stars would have created the difficulty of drawing into the investigation other points of the division possibly affected with different errors; an inequality of this kind was not to be apprehended with regard to the two above-mentioned stars, as the verniers of the circle cover spaces of $4^{\circ} 30'$, which are greater than the distance of these stars.

The places of the pole were determined from the beginning of the observations to the end of 1821, by applying the above determined thermometrical correction of refraction as follows:

	Period.	Position of Circle.	Place of the Pole.	Weight.
1	1820. March 6, 7	West	$33^{\circ} 42' 58''.12$	10.0
2	7, 8	East	$323 \quad 8 \quad 39.66$	10.0
3	11	West	$33 \quad 42 \quad 57.68$	2.0
4	16—17	West	$33 \quad 43 \quad 1.20$	5.0
5	19—28	East	$323 \quad 8 \quad 36.29$	10.2
6	April 6, 7	West	$33 \quad 42 \quad 52.76$	28.0
7	8—13	East	$323 \quad 8 \quad 41.05$	39.4
8	13—17	West	$33 \quad 42 \quad 57.42$	39.9

	Period.		Position of Circle.	Place of the Pole.	Weight.	
9	1820.	April	18—21	West	33° 42' 59.42	19.0
10			22—26	East	323 8 43.36	44.6
11			27—33	West	33 43 00.4	54.0
12		May	4—15	East	323 8 43.37	85.8
13			15—25	West	33 42 59.12	56.0
14			27—42	East	323 8 41.16	40.1
15		June	12—27	West	33 42 57.93	83.6
16			29—46	East	323 8 41.16	49.2
17		July	17—32	West	33 42 58.36	50.5
18			1—9	East	323 8 40.09	54.7
19		Aug.	9—19	West	33 42 58.05	39.8
20			21—38	East	323 8 40.60	52.4
21		Sept.	7—16	West	33 42 58.57	70.0
22			22—34	East	323 8 41.07	54.8
23		Oct.	12—32	West	33 42 59.64	38.6
24		Nov.	4—15	East	323 8 43.03	15.0
25			26—46	East	323 8 32.30	82.0
26		Dec.	16—25	West	33 42 50.46	83.6
27			29—34	East	323 8 29.54	41.2
28	1821.	Jan.	29—41	West	33 42 49.32	52.4
29			Feb.	11—28	East	323 8 32.28
30		March	3—25	West	33 42 48.97	34.0
31			26	East	323 8 31.15	10.0
32			26—31	East	323 8 34.45	34.2
33			31—49	West	33 42 50.08	54.5
34		April	20—25	West	33 44 2.69	37.5
35			25—35	East	323 9 46.21	50.9
36		May	5—23	West	33 44 3.22	44.5
37			25—35	East	323 9 46.06	47.5
38		June	9—17	West	33 44 2.98	50.0
39			18	West	33 44 1.66	10.0
40			23—30	East	323 9 44.54	47.4
41		July	2—20	West	33 44 1.21	34.2
42			Aug.	18—36	West	33 44 2.73
43		Sept.	5—29	East	323 9 44.95	31.5
44		Oct.	1—23	West	33 44 2.80	44.5
45			23—69	East	323 9 47.12	55.1
46		Dec.	11—31	West	33 44 5.71	31.0

With

With regard to this table, I observe that the greater differences which sometimes occur, as between the periods 11 and 13, 14 and 18, 43 and 45, 44 and 46, can hardly be ascribed to accidental imperfections of the observations, for they commonly agree very well, as may be seen in the journals; these differences appear to arise from small partly temporary, partly permanent changes of the line of collimation. Where two periods are separated by a line, something in the instrument has been altered either by accident or by design. From these data the height of the pole is found without further correction for flexure, error of division and refraction, on the supposition of an equal value of each period.

1 to 3 ...	54° 42' 50 ^h .80	weight = 2.0 periods
7 — 8 ...	51.81 2.0
9 — 13 ...	51.92 4.8
14 — 22 ...	51.32 8.9
23 — 24 ...	51.70 2.0
25 — 26 ...	50.92 2.0
28 — 31 ...	51.29 4.0
32 — 33 ...	52.18 2.0
34 — 38 ...	51.59 4.8
39 — 41 ...	51.55 2.7
42 — 46 ...	51.14 4.8
Mean	54 42 51.456	probable error = ± 0 ^h .0365.

The same observations have given the correction of the declinations of my tables of the two pole stars, of which I am obliged here to give that of α *Ursæ Majoris*, which I shall immediately have occasion to use, viz.

663 observations on the east side ... -0^h.452

782 west side ... -0^h.219

from which the declination for 1820 follows:

$$= 88^{\circ} 20' 54''.157 \text{ and } 54''.390.$$

The reflected image of the same star has been observed in 64 passages, in each from 4 to 6 times, both above and below the pole; 16 times in the eastern, and as often in the western position of the instrument. It would have been impossible to make so many observations of this kind in about 18 months, were it not possible to see the star likewise in the day-time by reflection from water. In the following table of these observations the first column contains the results of the circle corrected by the refraction of my table, and the above determined thermometrical correction; the second, the reduction to 1820; the third, the place of the pole; the fourth, the distance of the reflected

reflected image of this star reduced to 1820 from that point. To the arithmetical mean of each series the reduction of the basin of water to the centre of the instrument has been applied; for the latter is 5.625 Paris feet higher than the former, and therefore the reduction for the zenith distance $z = -0'.1182 \text{ tang } z$.

Upper Passage.—Circle East.

1820.						
July	12	212° 3' 49.47	+ 6.66	323° 8' 41.16	111° 4' 45.30	
Sept.	29	4 10.34	-15.56	8 41.07	46.29	
Oct.	1	4 10.75	-16.40	8 41.07	46.72	
	4	4 13.72	-17.55	8 41.07	44.90	
Nov.	4	4 24.75	-29.17	8 43.03	47.45	
1821.						
April	28	5 18.62	-20.69	9 46.21	48.28	
	29	5 19.33	-20.41	9 46.21	47.29	
May	3	5 18.42	-19.40	9 46.21	47.19	
June	1	5 12.24	-14.36	9 46.06	48.18	
	3	5 12.74	-14.22	9 46.06	47.54	
	23	5 11.30	-13.32	9 44.54	46.56	
	27	5 12.13	-13.40	9 44.54	45.81	
	28	5 10.31	-13.47	9 44.54	47.70	
	29	5 11.09	-13.56	9 44.54	47.01	
Oct.	27	5 48.10	-47.39	9 47.12	46.41	
	29	5 48.69	-47.17	9 47.12	45.60	
		Mean	- - - - -	- - - - -	111 4 46.748	
		Reduction of the water basin	- - - - -	- - - - -	- 0.079	
		Distance of the star from the pole	- - - - -	- - - - -	-1.39 5.610	
		Double altitude of the pole	- - - - -	- - - - -	109 25 41.059	

Upper Passage.—Circle West.

1820.						
June	23	144° 47' 55.24	- 8.12	33° 42' 57.93	111° 4' 49.19	
Sept.	9	47 38.50	+ 8.11	42 58.57	48.04	
	13	47 37.88	+ 9.49	42 58.57	48.80	
	15	47 36.77	+10.30	42 58.57	48.50	
Oct.	21	47 23.38	+23.99	42 59.64	47.73	
	22	47 21.50	+24.34	42 59.64	46.20	
1821.						
May	5	48 31.43	+18.98	44 3.22	47.19	
	8	48 31.90	+18.41	44 3.22	47.09	
June	13	48 38.75	+13.42	44 2.98	49.19	
	16	48 37.21	+13.42	44 2.98	47.65	
	17	48 37.39	+13.43	44 2.98	47.84	
July	2	48 35.89	+13.80	44 1.21	48.48	
	16	48 33.75	+15.23	44 1.21	47.77	
Oct.	12	48 8.51	+41.72	44 2.80	47.43	
	13	48 7.59	+42.08	44 2.80	46.87	
	21	48 5.85	+45.29	44 2.80	48.34	
		Mean	- - - - -	- - - - -	111 4 47.894	
		Reduction of water basin	- - - - -	- - - - -	-0.079	
		Distance of the star from the pole	- - - - -	- - - - -	-1 39 5.843	
		Double altitude of the pole	- - - - -	- - - - -	109 25 41.972	

Lower

Lower Passage.—Circle East.

1820.								
April	22	215° 22'	7'42"	+ 0'90"	323° 8'	43'36"	107° 46'	35'04"
	23	22	6'57"	+ 0'62"	8	43'36"		36'17"
May	8	22	11'25"	- 3'10"	8	43'37"		35'22"
	9	22	10'01"	- 3'36"	8	43'37"		36'72"
June	2	22	11'54"	- 7'06"	8	41'45"		36'99"
	3	22	11'62"	- 7'20"	8	41'45"		37'03"
	6	22	12'83"	- 7'56"	8	41'45"		36'18"
	9	22	13'50"	- 7'81"	8	41'45"		35'76"
	10	22	13'18"	- 7'85"	8	41'45"		36'13"
1821.								
March	27	21	30'43"	+30'11"	8	34'45"		33'91"
	29	21	31'00"	+29'53"	8	34'45"		33'92"
	30	21	29'68"	+29'23"	8	34'45"		35'54"
	31	21	30'08"	+28'89"	8	34'45"		35'48"
April	25	21	48'29"	+21'67"	9	46'21"		36'25"
	29	22	48'55"	+20'55"	9	46'21"		37'11"
May	4	22	50'02"	+19'30"	9	46'21"		36'89"
Mean - - - - -							107 46 35.896	
Reduction of water basin - - - - -							-0.089	
Distance of the star from the pole - - - - -							+1 39 5.610	
Double altitude of the pole - - - - -							109 25 41.417	

Lower Passage.—Circle West.

1820.								
April	14	141° 29'	34'58"	- 3'00"	33° 42'	57'42"	107° 46'	34'16"
	15	29	34'07"	- 2'70"	42	57'42"		33'95"
	17	29	35'07"	- 2'18"	42	57'42"		35'47"
	28	29	33'99"	+ 0'84"	43	0'04"		34'79"
May	3	29	33'34"	+ 1'94"	43	0'04"		35'24"
	24	29	28'36"	+ 6'11"	42	59'12"		35'35"
June	21	29	25'29"	+ 8'15"	42	57'93"		35'51"
1821.								
April	21	31	3'25"	-22'64"	44	2'69"		37'92"
	22	31	3'10"	-22'41"	44	2'69"		38'00"
	24	31	2'05"	-21'93"	44	2'69"		37'43"
May	5	30	58'26"	-19'09"	44	3'22"		35'95"
	15	30	58'21"	-16'91"	44	3'22"		38'08"
June	12	30	51'50"	-13'48"	44	2'98"		35'04"
	14	30	53'54"	-13'41"	44	2'98"		37'15"
	16	30	52'43"	-13'42"	44	2'98"		36'03"
July	2	30	51'87"	-13'76"	44	1'21"		36'90"
Mean - - - - -							107 46 36.061	
Reduction of the water basin - - - - -							-0.089	
Distance of the star from the pole - - - - -							+1 39 5.843	
Double altitude of the pole - - - - -							109 25 41.815	

The deviation of these determinations of the altitude of the pole from the one obtained above by reversing the instrument, proves a sensible *flexure*. Supposing it to be of such a nature that it might be counteracted in every position of the telescope with regard to the horizon, by applying invariable counter-

counterpoises, the correction of the result of the readings of the circle u arising from this cause, has the following form :

$$a \sin (u + 1^\circ 33') + b \cos (u + 1^\circ 33')$$

and the comparison of the five determinations above given produces $a = +1''\cdot1636$, probable error = $\pm 0''\cdot1008$

$$b = +0\cdot2025 \quad \dots \quad \pm 0\cdot0557$$

and next the altitude of the pole free from the error of flexure, and therefore only affected by the errors of division and refraction, = $54^\circ 42' 50''\cdot783$, with the probable error $\pm 0''\cdot0455$. The probable errors here given are founded on that of a passage observed by reflexion from water = $0''\cdot7277$, as the above observations give it. The agreement of the values of the altitude of the pole obtained by the single sets of observations, is as follows :

By reversing the instrument	$54^\circ 42' 50''\cdot814$		
By reflexion	}	Upper Passage East	$50\cdot720$
		West :	$50\cdot942$
	}	Lower Passage East	$50\cdot744$
		West :	$50\cdot726$

The other method for determining flexure I have carried into effect by combining the observations of α *Ursæ Minoris* with 69 western and 55 eastern observations of 9 southern stars. The distances from the pole of these 10 stars I have found for the year 1820 as follow :

Observations by direct Vision.				Observations by Reflexion.			
		Distance from the Pole.	$\frac{\delta}{Z}$		Distance from the Pole.	$\frac{\delta}{Z}$	Reduction.
α <i>Ursæ Min.</i>	East	358 20 54 ¹ / ₁₅₇		West	252 13 23 ⁹ / ₉₃₉		+0 ⁰ / ₀₈₉
	West	54 ³ / ₃₉₀		East	24 ¹ / ₁₀₄		+0 ⁰ / ₀₈₉
α <i>Ursæ Min.</i>	East	1 39 5 ⁸ / ₈₄₃		West	248 55 12 ¹ / ₁₀₆		+0 ⁰ / ₀₇₉
	West	5 ⁶ / ₆₁₀		East	13 ² / ₂₅₂		-0 ⁰ / ₀₇₉
δ <i>Leonis</i>	East	73 35 16 ³ / ₃₁	9	West	176 58 58 ⁷ / ₂	11	-0 ⁰ / ₀₉
	West	16 ⁴ / ₆	17	East	59 ⁶ / ₄	9	-0 ⁰ / ₀₉
β <i>Leonis</i>	East	74 25 17 ⁹ / ₀	13	West	176 8 56 ⁵ / ₄	10	-0 ⁰ / ₁₀
	West	18 ³ / ₄	17	East	56 ⁷ / ₇	8	-0 ⁰ / ₁₀
ζ <i>Bootis</i>	East	75 29 38 ⁰ / ₀	8	West	175 4 37 ⁶ / ₃	10	-0 ⁰ / ₁₀
	West	37 ⁷ / ₇	10	East	38 ⁶ / ₉	11	-0 ⁰ / ₁₀
α <i>Pegasi</i>	East	75 45 38 ⁹ / ₆	19	West	174 48 36 ⁵ / ₉	7	-0 ⁰ / ₁₀
	West	39 ² / ₃	15	East	37 ⁴ / ₉	4	-0 ⁰ / ₁₀
γ —	East	75 49 1 ⁹ / ₀	22	West	174 45 12 ⁶ / ₄	6	-0 ⁰ / ₁₀
	West	1 ⁹ / ₄	17	East	13 ³ / ₁	1	-0 ⁰ / ₁₀
α <i>Leonis</i>	East	77 9 24 ⁴ / ₈	22	West	173 24 51 ⁵ / ₂	8	-0 ⁰ / ₁₁
	West	24 ⁶ / ₀	28	East	51 ³ / ₀	6	-0 ⁰ / ₁₁
α <i>Ophiuchi</i>	East	77 18 2 ⁵ / ₂	11	West	173 16 12 ⁶ / ₉	8	-0 ⁰ / ₁₁
	West	2 ⁴ / ₂	21	East	13 ³ / ₅	6	-0 ⁰ / ₁₁
σ <i>Leonis*</i>	East	82 59 7 ² / ₈	7	West	167 35 6 ⁷ / ₆	3	-0 ⁰ / ₁₃
	West	7 ⁶ / ₀	14	East	9 ³ / ₇	5	-0 ⁰ / ₁₃
α <i>Serpentis</i>	East	83 0 3 ² / ₄	21	West	167 34 13 ⁷ / ₇	6	-0 ⁰ / ₁₃
	West	3 ⁰ / ₄	31	East	15 ⁴ / ₁	5	-0 ⁰ / ₁₃

* The observations taken by reflexion of this and the following star are somewhat less accurate than the rest; it was necessary to open the lower side shutter, which remained closed when higher stars were observed, and thus diminished the draught of air.

The

The sum of the distances from the pole, measured by direct vision and by reflexion, is the supplement of the double altitude of the pole to 360° ; but it is to be corrected for flexure. Hence I find

$$a = +1''\cdot0646, \text{ probable error} = \pm 0''\cdot0563$$

$$b = +0\cdot3175 \text{ ——— ——— } \pm 0\cdot0483$$

The altitude of the pole free from the error of flexure is $= 54^\circ 42' 50''\cdot794$, with the probable error $\pm 0''\cdot0911$. The basis of this computation is the probable error of a direct observation $= 0''\cdot7613$, and that of an observation by reflexion $= 1''\cdot026$; from which follows that of the double altitude of the pole from a observations of the first, and a' of the second kind

$$= \sqrt{\left\{ \frac{(0''\cdot7613)^2}{a} + \frac{(1''\cdot026)^2}{a'} \right\}}.$$

The following table contains the single results with and without the correction, as also the probable errors.

	Double uncorrected Altitude of the Pole.	Probable Error.	Corrected Altitude of the Pole.
α Ursæ Minoris	$109^\circ 25' 41''\cdot815$	"	$54^\circ 42' 50''\cdot70$
Lower Passage.	41·417	0·1819	50·92
α Ursæ Minoris	41·972	0·1819	50·77
Upper Passage.	41·059	0·1819	50·74
θ Leonis	45·06	0·4118	51·00
	43·99	0·3886	50·87
β Leonis	45·66	0·3870	51·35
	44·99	0·4070	51·29
ζ Bootis	44·47	0·4219	50·67
	43·64	0·3919	50·66
α Pegasi	44·55	0·4260	50·71
	43·38	0·5493	50·52
γ Pegasi	45·56	0·4493	51·22
	44·85	1·0423	51·26
α Leonis	44·11	0·3973	50·48
	44·21	0·4428	50·92
α Ophiuchi	44·90	0·4292	50·89
	44·34	0·4493	50·96
σ Leonis	46·09	0·6584	51·41
	42·66	0·5018	49·99
α Serpentis	43·12	0·4505	49·92
	41·68	0·4787	49·50

The mean agreement of the result is obtained by both methods; and the great number of observations from which they

have been derived lead us to expect that no considerable uncertainty remains with regard to the quantity of this element, which affects all determinations; for the following calculations I shall adopt $+1^{\text{h}}.11 \sin (u + 1^{\circ} 33') + 0^{\text{h}}.26 \cos (u + 1^{\circ} 33')$; and from this formula the above given corrections of the single sets of observations have been deduced.

[To be continued.]

XXIX. *On the Velocity of Sound; and on the ENCKE Planet.*

By Mr. JOHN FAREY.

To the Editors of the Philosophical Magazine and Journal.

Gentlemen,

I HAVE felt much gratified by the perusal of Dr. Gregory's late Experiments on the Velocity of Sound in p. 401 of your last volume; his practical Rule derived from which, may I think prove of great use on many occasions; and in the mean time, until the Doctor's leisure will enable him to complete his proposed series of Experiments, I beg to present his practical Rule for calculating the Velocity of Sound, in a somewhat simpler form than it is delivered in p. 411, and to show its agreement with the mean results of all his Experiments; one of which, at 59° of temperature, viz. 1111 feet (not 1113 as printed in p. 407), and another at 66° , viz. $1115\frac{1}{4}$ feet, have I find been omitted to be brought forwards, and included in the average velocities in his Table, but which now I have supplied.

RULE.—*To the constant number 1082.7, add half the number of degrees of Fahrenheit's scale, at the time of observing any distant Sound, the sum will be the velocity in feet, of its transmission through the air, in the climate of London.*

Temperature, Fahrenheit's Degrees.	Pressure, in Inches of Mercury.	Observed Velocity in Feet.	Velocity, calculated by the Temp.
27	29.82	1094.2	1096.2
33	29.87	1099.2	1099.2
35	29.98	1102.0	1100.2
45	29.66	1107.7	1105.2
59	29.67	1110.1	1112.2
60	29.68	1112.0	1112.7
64	29.83	1115.1	1114.7
66	29.82	1116.1	1115.7

According

According to this Rule, a temperature of $118^{\circ}6$ would be necessary to produce a velocity of 1142 feet per second, as given by Dr. Derham's Experiments, and adopted by Newton, but certainly his Experiments were not made at so high a temperature as this.

I have in column 2 added the mean pressures observed in Dr. Gregory's Experiments, in order to examine, whether they would appear to bear (as it is evident they do not) any such relation to the velocities, as seems indicated by Mr. Ivory in page 426 of the same volume, by the expression $\sqrt{32\frac{1}{6} \times l \times \frac{4}{3}}$, or its equivalent $6.549 \sqrt{l}$, for the velocity, in feet, of Sound per second; l being the height of a supposed homogeneous atmosphere, in feet.

Now since mercury is about 11,262 times the weight of air, in a mean state, at the earth's surface; we have $l = \frac{1}{12} \times 11262 \times m$; m being the height in inches of the barometric column of mercury, balancing such an atmosphere; and the above expression becomes, $200.63 \sqrt{m}$, = the velocity of Sound per second, in feet.

The pressures, or mercurial columns m , being the same, viz. 29.82 inches, when the *greatest* and when the *least* velocities were observed by Dr. Gregory (the difference being 21.9 feet), it seemed useless for me to calculate, in a fifth column, the velocity of each of his observations, by the formula last mentioned: I will do so, however, for *the mean* of all the Doctor's observations, as to pressure and velocity; and these I find to be 29.79 inches, and 1107 feet. Accordingly $200.63 \times \sqrt{29.79} = 1095.3$; which is 11.7 feet less than the mean of the observed velocities.

If by this same formula we calculate, what must be the pressure, to occasion a velocity of 1142 feet per second, we

have $\frac{1142}{200.63}^2 = 32.40$ inches; which is a barometric pressure,

not less excessive, than we have just found the temperature to be (according to the first of these Rules, which are but empirical ones) for producing this velocity, which so long has been received as the mean velocity of Sound.

If we compare in p. 414 Mr. Goldingham's Temperatures with his velocities, we shall find his *minimum* temperature in February, but his least velocity in December; and again, his *maximum* temperature in May, but the greatest velocity in July; whence it is manifest, that no Rule on the same principle as Dr. Gregory's wherein the velocities are directly as the temperatures, can be applied to represent the velocities of Sound at different seasons, at Madras.

On comparing the pressures at Madras with the velocities, a principal *minimum* of pressure appears in May, and an inferior one in December; also two almost equal *maxima* in November and January, instead of one least velocity in December and one greatest in July, as above mentioned. Also, in the Table given in p. 178, between 35° and 45° of Temperature, the pressure decreases $\cdot 32$ inches, whilst the observed velocity increases 5.7 feet; all which show the velocities, not to be in the direct sub-duplicate ratios of the pressures, although Mr. Ivory appears, in p. 426, to consider that this assumption "agrees sufficiently well with experiment:" — perhaps this able mathematician, whose communications do so much honour to the pages of your Magazine, will oblige me and others of your Readers, by detailing the Experiments to which he alludes, or otherwise illustrating the subject.

I consider it very fortunate for Astronomical Science, that the discovery has been made by M. Encke, of a Comet, moving in an orbit with so small a major axis, as in my humble opinion, well to entitle it to be designated the *Encke Planet*; and I am particularly pleased that its sensibly decreasing periods of revolution, has drawn the attention of M. Massotti (see p. 457 of your last volume) to consider the effects of a peculiar and very rare atmosphere of the Sun, as most probably occasioning, by its resistance to this planet, when in perihelio, the obvious loss of part of its motion on each return.

I think it extremely probable, that there are several other small planets, having rather excentric, although not large orbits, yet undiscovered, but with which the laudable vigilance of astronomers will ere long make us acquainted; and that the different degrees of approach of these to the Sun, when in perihelio, considered in connection with their periodic decrease of orbit, respectively, will fully demonstrate the existence and the law of density and resistance of the solar atmosphere.

I am sanguine also in thinking, that the multitudes of *Satellitulae* which revolve round our planet*, in orbits which though considerably excentric, do not probably carry them beyond the orbit of the Moon, will ere long receive attention from astronomers; by the united labours of two or three of whom, the periodic return of some of these *Satellitulae* might be ascertained, and the length of course which each one periodically makes through the higher part of our atmosphere, whilst exhibiting the appearance of a shooting Star, might be determined; and its accelerated periods of return to perigeo, might, on similar principles of calculation to those lately applied to

* See vol. lvii. p. 346, vol. lviii. p. 183, &c.

the Encke Planet, be reconciled with the density and resistance of our atmosphere, at the part traversed; whereby the theory of partially resisted planetary motion, in general, as well as the height and constitution of our atmosphere, would receive important illustration.

In p. 350 of your 57th volume, I have endeavoured to point out an important use which might immediately be made of the shooting Stars, in accurately settling the longitudes of places on Land: and I beg in conclusion here to mention, *the instantaneous vanishing* of these shooting Stars, and of satellitic Meteors, generally, on their *passing the oxygenous limit* of our atmosphere, as phænomena, capable of being pretty accurately observed, by two or three observers acting in concert, at places rather distant, whose relative positions were known, trigonometrically; and to hint at the importance which it might prove to science, to know *the height of this oxygenous limit*, under the various circumstances of Pressure, Temperature, Moisture, Electrical State &c. of the Air.

I am, gentlemen,

Your obedient servant,

Howland-street, July 3, 1824.

JOHN FAREY.

XXX. *Observations on the Twelfth Book of Euclid.* By
J. WALSH, Esq.

“This I say to encourage those who are not far gone in these studies, to use intrepidly their own judgement, without a blind or a mean deference to the best of mathematicians, who are no more qualified than they are, to judge of the simple apprehension or the evidence of what is delivered in the first elements of the method.”—Berkley, *Defence of Free Thinking in Mathematics.*”

IT is true, the man who knows not A from B perceives as clearly the first principles of geometry, as the most expert analyst. It does not require the aid of deep science to perceive that the whole is greater than its parts; or that the line, which is the shortest distance between two points, is a straight line, that it does not bend more to any one side than it does to any other. But some one, not satisfied with the immediate evidence of his senses, that a straight line is shorter than any curve line terminated by the same two points, thinks he can prove the proposition in this way:—He makes the straight line the base of a triangle, having its vertex in the curve line, then the sum of the two sides of the triangle is greater than its base; in the same manner he makes the sides of the triangle the bases of other triangles having their vertices likewise in the curve line, and so on; then he thinks he has proved

proved that a straight line is the shortest distance between two points, notwithstanding that by such a way of reasoning the same proposition would always remain to be proved, that a straight line is the shortest distance between two points. I shall observe that, exactly on a similar ground of reasoning, if the curve line be made the base of a triangle, having its vertex in the straight line, then the base or curve line is less than the sum of the two sides; and if the sides be made the bases of other triangles, having their vertices also in the straight line, and so on as before; then it would appear that any curve line is the shortest distance between two points. To attempt to prove that a straight line is the shortest distance between two points by any intermediate propositions, is to attempt to prove that the whole is greater than its part: it is to attempt to prove, in fact, that a straight line is a straight line. It may be objected here, perhaps, that the calculus of variations proves the proposition under consideration. I shall observe, in reply, that there seems to be a lack of intimate acquaintance with some of the results obtained by it among all the writers on that calculus. This will appear by an extract from the *Calculus of Functions of Lagrange*, page 475:—

“ L'équation générale donne tout de suite $\frac{y'}{\sqrt{(1+y'^2)}} = a$ une constante; d'où l'on tire $y' = b$, et de là $y = bx + c$, b et c étant deux constantes arbitraires; ce qui est l'équation générale de la ligne droite.” The result here obtained is, that for all the points of the axis of x , which axis is the straight line terminated by the given points, for all the values of x , the co-ordinate of the shortest line has a determinate magnitude; therefore, the shortest line between two points cannot pass but through one of them. Such is the absurd conclusion to which the reasoning leads. Whether the defect is in the reasoning, or in the calculus, I shall not now inquire. Quite the reverse of this is the binomial calculus, which is very explicit on this subject. The binomial of any curve line is $\frac{n}{y} dx$; and in the case of maximum or minimum, $\frac{n}{y}$ is nothing; then n is nothing and y is nothing. The calculation does not go further than to show that this happens when x is nothing, and when x becomes the straight line terminated by the points; proving only, that the shortest line must pass through the given points; thus ending at the point at which we set out, and leaving the mind to shift for itself in determining, among all lines terminated by two given points, which is the shortest. I interrogate the binomial calculus on the shortest distance between

between two points; and it leads to the conclusion, that it can only be determined by the immediate evidence of the senses, that science cannot afford any aid.

The man who knows not A from B, perceives as clearly as the most expert analyst, that when a straight line intersects any one of two parallel straight lines, it will intersect the other also, produced, if necessary. The mind is mediately led to this perception, by the idea that a straight line does not bend more to one side than to another. But some one more deeply read in science, not satisfied with the immediate evidence of his senses, thinks he can prove the axiom mediately. He talks of functions and homogeneity: he says angles are numbers, and that lines are not numbers. And then he thinks he has proved by numbers and homogeneity, that two straight lines that are not parallel to each other will meet when produced! I cannot perceive the real tendency of such reasoning. It is severely reprehended by the illustrious Newton, page 17, Motte's Translation of the Principia: "Relative quantities," says he, "are not the quantities themselves whose names they bear, but those sensible measures of them (either accurate or inaccurate) which are commonly used instead of the measured quantities themselves. Those do defile the purity of mathematical and philosophical truths, who confound real quantities themselves with their relations and vulgar measures." Surely angles are no more numbers than are sticks and stones. Physics inquires into the nature of things; geometry into their relations. No magnitude can enter into calculation, but through its relation to some arbitrary base of comparison. The first axiom I have here noticed is, that the whole is greater than its part. The second, that the shortest distance between two points is a straight line. This axiom, though more complex than the first, as depending on it, yet is not susceptible of any proof beyond the immediate evidence of the senses. The third, that when a straight line intersects any one of two parallel straight lines, it is not parallel to the other. This axiom, though more complex still than the second, as depending on the second, is notwithstanding incapable of any proof, but what is presented by our perception of a straight line, that it does not bend any more to one side than it does to another. Here I would be understood to avoid all discussion about the meaning of words. If I know the idea the word is intended to impress, I care not whence it was derived, or why different nations make use of different sounds to impress the same idea. My object is to free the first principles of geometry from sophistical cavilling; principles that are as evident to the illiterate, as to the most profound mathematicians.

The

The first proposition of the tenth book of Euclid says, "If from the greater of two unequal magnitudes there be taken away more than its half, and from the remainder more than its half, and so on, there shall at length remain a magnitude, less than the least of the proposed magnitudes." This proposition, on a slight view of it, appears very specious. But by examining it more deeply, we shall perceive that it asserts the absurdity, that a magnitude is less than itself. In effect, let any indeterminate magnitude be the greater, and any indeterminate part of it be the less; then, if from the greater there be taken away more than its half, and from the remainder more than its half, and so on, there shall at length remain a magnitude less than any indeterminate part of the whole: but the remaining magnitude is an indeterminate part of the whole; therefore there shall at length remain a magnitude that is less than itself. Such is the true nature of the absurd lemma of the ancients, and of all similar propositions. And such is the nature of the sophism, by which Euclid has attempted to demonstrate the chief propositions of the twelfth book of his Elements. The properties of the circle, sphere, cone, and cylinder, were deduced by analogy from the like properties, demonstrated to belong to figures bounded by straight lines and plane surfaces. These properties, with regard to the round figures, are demonstrated algebraically by the binomial calculus; but they are not yet demonstrated by elementary geometry.

The excrescences that have accumulated on the sciences of geometry and algebra should be pruned;—sciences that have tended more to the advancement of society than all others. They should be freed from all empirical reasoning. They should be placed before young mathematical students in their real state, that their judgements may not be warped, and that aspiring genius may with the more effect exert itself in discovering the yet latent principles of these sciences.

Cork, Aug. 2, 1824.

J. WALSH.

XXXI. Decas novarum Plantarum Succulentarum; *Autore* A. H. HAWORTH, *Soc. Linn. Lond.—Soc. Horticult. Lond.—necnon Soc. Cæsar. Nat. Curios. Moscoviensis Socio, &c. &c.*

To the Editors of the Philosophical Magazine and Journal.

Gentlemen,

HEREWITH I have the satisfaction of forwarding to you, for your Magazine, a pretty complete description of ten new species of succulent plants, belonging or allied to the genus

Crassula

Crassula of Linnæus, which have recently been discovered in the wilds of Southern Africa, and sent to the Royal Gardens of Kew by one of His Majesty's most successful botanic collectors, Mr. Bowie, whose enterprising spirit has not only detected, but successfully forwarded to those rich gardens in a living state, more succulent plants than any individual now existing.

Another new succulent plant allied to *Aloë*, I have called *Bowiæa africana*; thus endeavouring to hand down the name of this meritorious discoverer, in one of the African plants which he alone has found, to the botanists and travellers of future days; a compliment he well deserves and has so arduously earned. Of this new genus, now blooming for the first time in Europe in our gracious Sovereign's delightful collections at Kew, I hope to be able to send you a complete description for your next Magazine, favoured, as I have ever been in my endeavours to advance the investigation of the succulent plants, by my kind friend W. T. Aiton, Esq., the able conductor of those celebrated gardens.

And I remain, gentlemen,
 With respectful esteem,
 Your most obedient servant,

Chelsea; Sept. 1824.

A. H. HAWORTH.

Classis et Ordo. PENTANDRIA PENTAGYNIA.

KALOSANTHES *Nob. in Revis. Pl. Succ. p. 6.*—*Dietrichia* *Tratt. Arch. d. Gewächsk. n. 449.*—*Crassula* *Linn. &c.*

Inflorescentia involucretim subcapitata. *Corolla* 5-fida, infundibuliformis, laciniis tubo triplo brevioribus. *Cætera* ut in *Larochæa* genere, *Crassulæve*.

Plantæ *Africanæ* valde succulentæ, foliis opposite decussatis.

biconvexa. *K.* (convex-leaved) foliis angustioribus linearibus
 1. supra subtusque distinctè connexis. *Florebat* Julio A.D. 1824, in Regio Horto Kewense. *G. H. h.*

Obs. Affinibus minor, in omnibus atque gracilior, foliorum marginibus cartilagineo-asperiusculis. *Flores* emortuos post florescentiam duos insuper vivam plantam solum vidi terminales altèque tubatos (affinium more), tubo calyce duplo longiore. *Styli* in sicco (an semper?) usque ad apices quasi coadunati.

Prope *Crassulam* capitatam *Lamarckii*, in *Enc. Meth.* (quæ bona species) locanda, sed duplo plusve minor quam illa.

Obs. In the year 1821 I published the genus *Kalosanthes*
 Vol. 64. No. 317. Sept. 1824. A a thes

thes in the *Revis. Pl. Succ.*, not being then aware of some of the same plants having been given by Tratténick under the name of *Dietrichia* in 1812, nor that the name of *Dietrichia* itself had been given to other plants by Rauschel in 1797. Wherefore the name of *Kalosanthes* may remain. The genus is sound, and I suspect will differ from *Larochea* in the formation of the stigmata, but without recent flowers I cannot say to what extent: from every other it is far apart.

CRASSULA *Linn. &c.*

Inflorescentia cymosa. *Corolla* 5-petaloidea expansa, s. campanulatum erecta, laciniis basi ipsæ, solum coalitis imbricantibus. *Germina* 5 cum stylis continuantibus subulata.

Suffrutices s. Herbæ succulentæ, e Capite Bonæ Spei præcipuè; foliis (paucis exceptis) oppositè decussatis, corollis albis, roseis, luteisve.—*Nob. in Revis. Pl. Succ.*

p. 9.

biplanata. C. (flat-leaved) ramosa, foliis suberectis lævibus subulatis acutis, utrinque planis, subtus subcanaliculatis.

2.

Floret Septemb. G. H. ½.

Plantæ juvenes, semipedales læves erectæ; at fere floriferas solum vidi fine Augusti A.D. 1824. *Rami* subpatentes teretes, aère aperto rufescentes. *Folia* semunciam longa, superiora erectiora, inferiora subpatentia, internodiorum longiora. *Flores* terminales in cymis capitatis paucifloris affinium more, incipientes inapertos solum vidi. *Bractææ* fere ut in *Cr. acutifolia Decand.* at majores. *Corolla* quoque affinium, petalis oblongo-ovatis filamentisque niveis. *Antheræ* crassæ obtuso-cordatæ, longiores quam latæ, (in lente) ruberrimæ.

Ordinaria *squamula* quadrata minutissima luteola. *Pollen* non vidi. Prope *Cr. acutifoliam* locanda.

bibracteata. C. (double-bracted) effuso-decumbens, radicans:

3.

foliis subulatis expansis supra planis sulcatisve, bractæis pedunculi communis semper duabus.

Floret Aug.—Sept. G. H. ½.

Obs. Suffrutex dodrantalis glaber dumosus. *Folia* perfoliata acuta, viridia, extus convexa, sæpius supernè canaliculatim concava; expansa, sive incurva, seu incurvo-recurvula, vel in senectute recurva, internodiorum longiora, subuncialia. *Flores* minuti, primò terminales, mox laterales, pedunculo communi 4-5-unciali, et per lentem lineolis punctisve longitudinaliter confluentibus notato, supra medium bibracteato. *Bractææ*

teæ

teæ minutæ lato-subulatæ supra sulcatæ pedunculo adpressæ. Aliæ quoque adsunt bracteolæ minutissimæ per paria, ad dichotomiarum basin, ut in affinibus. *Calyx* parvus 5-partitus campanulatus, foliolis parabolicis viridibus, apicibus aëre aperto sæpe plus minus fuscis, purpureove-fuscescentibus. *Corolla* campanulata 5-partita nivea, laciniis erectis late ovatis obtusis, basi solum coalitis, unoque latere aliquantillum imbricantibus. *Stamina* 5, filamenta nivea, corollâ parum breviora, antheris polliniferis sulphureis; defloratis fuscis. *Styli* (cum germinibus) obpyriformes, extûs gibbuli, internè planiores. *Squamula* ordinaria, brevis, emarginatim sublunuliformis si optimè visa per lentem.

Obs. Planta parum variat, ut ferè omnes succulentæ plantæ e spontaneis seminibus ex Africa ortis.

α. minor: sæpe rufescens: foliis supernè minus sulcatis planisve, subinde subtus rufo-punctatis.

β. major: virescens: foliis supernè sæpius sulcatis, sæpeque rufo-punctatis, ramulis paulo-longioribus quam var. *α.*

Obs. Præcedentia finis, at *Crassulæ acutifoliæ* proxima, sed multò major, robustior, et inde erectior; necnon nihilominus omnino decumbenter-radicans undique; rursumque assurgentibus ramulis. In *Crassula acutifolia* pedunculi communes gerunt semper bractearum duo paria remota, infra dichotomiam, et par alium, dichotomiam amplectens. Verbo tenus, hæc planta specifico nomine solùm, ab affinibus proximis certissimè distinguitur.

filicaule. C. (thready-stemmed) effuso-dichotoma: foliis patienti-recurvulis parvis; ramis radicanibus filiformibus.

4.

Florebat in Regio Horto Kewense autumnò 1822. G. H. h. s. ♂.

Obs. Fruticulus vix semipedalis ramosissimus debilis: sive Herba 2-3-ennis, aëre aperto rubescens. *Rami* et *ramuli* tenuissimi teretes, erecto-effusi decumbentes intertexti, et undique altè radicanes, elongatis simplicibus fibris. *Folia* adulta lanceolate-subulata 4-5-linearia, patienti-parum-recurvula lævia viridia, sive rufescentia, internodiorum sub longitudine; subtus convexa; juniora confertiora incurva subcanaliculata. *Flores* subcymosi terminales exigui pentapetaloidei albi, stellatim expansi, pedunculis longitudine foliolorum bracteaceorum. *Stamina* filamentis quinque, antheris pollinosis luteis. *Styli* totidem quinque.

Præcedentibus multoties minor, sed fortassè affinium
Crassulæ acutifoliæ.

Cætera non examinavi.

revolvens. C. (recurving-leaved) foliis linearibus macris
5. acutis revolutis-reflexis arcuatisve subdistantibus: cau-
libus gracilibus longulis subramosis.

Floret autumnò, ni fallor, apud Kew. G. H. 7.

Obs. Suffrutex gracilis fere pedalis tantillum ramu-
losus, ramulis erectis subfiliformibus et per lentem pu-
berulis, at per ætatem cum debili caule decumbentibus
plus minusve. *Folia* basi, quasi connato-tumidula,
utraque plana, sive infernè aliquantillum tumidula, re-
mota, vel sine dubio inter remotos internodiorumque
longiora. *Flores* ni malè memini (necnon apud Kew
audivi) parvi albi, in capitulis densiusculis terminali-
bus; sed non examinavi.

Fortasse ad Crassulam fruticosam Linnæi accedit
proximam, sed caulibus corvi calami longè tenuioribus,
nec "digiti crassitie," ut in Cr. fruticosa. In aliis
characteribus proculdubio longè recedit.

rotundifolia. C. (round Orpine-leaved) subherbacea s. per-
6.ennis: erecta: foliis petiolatis subrotundis firmis pau-
cidentatis, imis integerrimis.

Florebat in Regio Horto Kewense autumnò A.D. 1822.

Obs. Caules simplices teretes crassi virides fere ut
in Sedo Telephio Linn., at minores, humiliores. *Folia*
opposita expansa orbicularia crassa nitentia subglauca
viridiave, internodiorum longiora; ima magis rotun-
data integra vel quam cæteris integriora, planiora:
superiora, supra inflexo-concava ovato-rotunda tri-
plinervia sescuncialia in petiolos 3-lineares supra
sulcatis sensim desinentia; supernè sæpe obsoletè den-
tata, sive subrependo-dentata: ad lentem lucemque
tenuissime pallido marginulata. *Flores* parvi albi in
capitulis cymosis terminalibus.

Cætera non examinavi.

GLOBULEA. Nob. in *Synops. Succ.* 60. — *Aliorum*
Crassula. Corolla petala 5 inaperto-erecta, apice glo-
bulum sive glandulam cerinam ferentia. Cætera ut in
Crassula.

impressa. G. (impress-dotted lance-leaved) acaulis: foliis
7. lorato-lanceolatis viridibus impresso-punctatis, punctis
magnis sparsis numerosis. *Florebat* in Regio Horto
Kewense autumnò A.D. 1823.

Obs. Habitus Turgosiæ pertusæ Nob. in *Revis.*
Pl.

Pl. Succ. p. 14 et p. 291. *Folia* subquadriuncialia crassa cespitosè decussata, ima sæpe glandulosè subciliata, ciliis (per lentem) albis falcatis recurvulis. *Scapus* bracteatis foliosus subpaniculatus, ramulis densè capitulatim cymosis; floribus parvis pallidis.

Cætera non examinavi.

β *minor.* duplo, impressis punctis obsoletioribus.

Obs. Sectionem novam formavit, foliis lanceolatis, loratisve.

atropurpurea. G. (The dingy purple) foliis oblique cuneato-
8. obovatis cultratis atropurpureis; scapo cauleve florifero longissimo paniculato.

Florebat in Regio Horto Kewense A. D. 1824, Augusto mense. G. H. 4. s. 2.

Obs. Caudex s. caulis 3-4-entis. *Folia* fere ut in *Crassula cultrata* Linn., at aère aperto plus minus atropurpurea. *Flores* dense glomerati in paniculæ distantium ramorum apicibus sesquipedalis aphyllæ. *Petala* valde erecta alba s. pallida, apicibus caudato-productis globuliferis, subpatentibus, demum recurvulis.

Est *Crassula* obliqua, β . *Nob. in Revis. Pl. Succ.* 204.

Pone *Globuleam* (*Crassulam* Linn.) cultratam locanda, cui proxima forte, cum alio modo florendi.

mesembryanthoides. G. (Hedge-hog ficoid-like) Suffrutex
9. dumosus erectus dodrantalis: ramis, ramulis, foliis subulatis, calycibusque hispidis.

Florebat apud Kew autumno A. D. 1823. G. H. 2.

Obs. Variat.

α . foliis semiteretibus subulato-incurvis succulentis, sive subaqueose pulposis confertis, floribus terminalibus glomeratim capitatis sessilibus confertissimis.

β . parum altior foliis remotioribus, florum capitulis cymose congestis, minus fortasse confertis.

Obs. In ambabus varietatibus pili albi densi in ramis ramulisque sunt expansi vel horizontales; sed in foliis semper respicientes.

Obs. *Flores* in α . sessiles, formantes cymas densissimas dichotomas capitulatas hirsutas, quasi absque proprio pedunculo communi. *Corolla* inaperta, sed ante anthesin solum examinavi, 5-petala. *Petala* erecto-adpressa oblonga lutescenti-alba, marginibus (ad lentem) puberulis, apicibus angustate-productis, et peltâ minutâ rufescente, potius quam globulâ finientibus. *Filamenta* alba. *Antheræ* innuptæ obtuso-

obtusum-cordatæ luteæ, longiores quam latæ. *Styli* (incipientes) cum germine breves figurâ seminis vitis viniferæ, at longe minores. *Squamula* ordinaria truncatim quadrata latior quam lata luteola.

subincana. G. (hoary shrubby) foliis semiteretibus subulatis acutis patenti-incurvulis, ramulisque molliter incanescens.

10. *Florebat* in Regio Horto Kewense mense Augusto A.D. 1824. G. H. 7.

Obs. Variat.

α. decumbens: Suffrutex: erecto-decumbens; dodrantalis; ramulis teretibus gracilibus irregularibus; more affinium sæpe radicantibus insuper terram; rursumque tunc assurgentibus; internodiis folio brevioribus. *Flores* terminales cymoso-capitati conferti albi affinium.

β. erecta: foliis confertioribus brevioribus minus incurvis.

Obs. Forte propria species. Cum *α.* crescit et floret.

Obs. Proximè affinis in habitu et caractere *Crassulæ* molli, Aitoni, quæ hujus generis est, et major: cum duabus præcedentibus speciebus sectionem novam formavit.

Hujus generis futuras Sectiones, ut infra et aptas, sed diffidenter propono.

1. **CULTRATÆ**, foliis cuneato-obovatis cultratis, caule suffruticoso:

1. *cultrata* (*Crassula*) Linn.
2. *atropurpurea* supra.

2. **LINGUATÆ**, foliis loratis obtusis subtus convexis, sive angustè linguiformibus, quadrifariam exactè imbricatim cespitosis, caule nullo herbaceove, scapis florigeris, defoliatis.

3. *lingua*, Nob. in MS.

4. *lingula*, Nob. in MS.

5. *capitata*, Nob. in Revis. Pl. Succ. cum descript. — *Salm. Cat. Hort. Dyck.*, nomen solum, sine descript.

Obs. *Flores* ut in sequente. Non est *Crassula capitata*, Lam. in *Encyclop.* quæ cel. Schultes reduxit in ejus *Syst. Veg.* 5. 708, ad varietatem *Crassulæ cymosæ* Linn., et quæ est bona species generis *Dietrichia* supra.

6. *obvallata*, Nob. (*Crassula* Linn.)

7. *canescens*, Nob. in *Synops. Succ.*

3. **LORATÆ**,

3. *LORATÆ*, foliis loratis, apicem versus sensim angustioribus, subtus convexis, quadrifariam imbricatim cespitosis, caule herbaceo, scapis foliosis.
 8. *impressa*, supra.
 9. *hispida*, Nobis MS.
4. *ANGUSTATÆ*, foliis linearibus semiteretibus sulcatis teretibusve. Herbæ cespitosæ scapis defoliatis. Hæc sectio fortassè melius antè priorem?
 10. *sulcata*, Nob. in *Revis. Pl. Succ.*
 11. *nudicaulis*, Nob. *Crassula nudicaulis* Linn.
5. *SUBULATÆ*, Suffrutices dodrantales ramosi, foliis subulatis, carnosis, supra planiusculis; floribus dense cymoso-capitatis terminalibus.
 12. *Mesembryanthoides*, supra.
 13. *mollis*. *Crassula mollis*, Aitoni aliorumque, sed hujus generis omnino.
 14. *subincana*, supra.

POSTSCRIPT.—Of the new species in the above list marked MS. you may expect a further account as soon as they produce their fructifications.

It may probably excite some surprise to see so many new Crassulæan plants here enumerated; and yet they are not all the unrecorded species the writer is well acquainted with. And more still, may be expected soon from abroad, especially from Southern Africa (Nature's great store-house for succulent plants), and where, perhaps, full half as many of the present tribe actually exist, as of *Mesembryanthema*; which last vast group may at length be found to rival or surpass in number, if not in elegance and beauty, the more extensively discovered Heaths: for Mr. Bowie assures me that he has seen in Africa a great number of native succulent plants of various kinds, which he has not been able to send to England in a living state.

XXXII. *Some Remarks on the supposed Influence of the Pollen in Cross-breeding, upon the Colour of the Seed-coats of Plants, and the Qualities of their Fruits.* By THOMAS ANDREW KNIGHT, Esq. F.R.S., &c. President.*

IT has been long ago ascertained by physiologists, that the seed-coats, or membranes which cover the cotyledons of the seeds of plants, with the receptacles which contain such

* From the Transactions of the Horticultural Society, vol. v. Part IV. seed-

seed-coats, are visible some time before the blossoms acquire their full growth; and the existence of these organs is therefore obviously independent of the influence of the pollen upon the growth of the internal and essential parts of the future seeds. The seed-coats also, and the fruit of some species of plants, acquire nearly, if not wholly, their perfect growth when the pollen has been entirely withheld, or when, from other causes, it has not operated; and from these circumstances, and other observations, it has been inferred, that neither the external cover of the seeds, nor the form, taste, or flavour of fruits, are affected by the influence of the pollen of a plant of a different variety or species. There exists, however, some difference of opinion upon these points; and the experiments of Mr. Goss upon the Pea, of which an account is given in a paper recently printed in the Transactions of the Horticultural Society*, appear strongly to countenance the opinion, that the colour of the seed-coats at least may be changed by the influence of the pollen of a variety of a different character; and hence he infers, with apparent reason, the probability that the taste and flavour of fruits may be also affected.

The narrative of Mr. Goss is unquestionably quite correct; but I believe that there is an error in the inference which he has drawn; and I am anxious that such error, if it exist, should be pointed out; because it may occasion many experiments to be made to prove that which I conceive to have been already sufficiently proved; and, consequently, cause the useless expenditure of time and labour, which might be advantageously employed in similar investigations upon other plants in the wide and unexplored field which lies open to the experimental horticulturist.

The numerous varieties of strictly permanent habits of the Pea, its annual life, and the distinct character in form, size, and colour of many of its varieties, induced me, many years ago, to select it for the purpose of ascertaining, by a long course of experiments, the effects of introducing the pollen of one variety into the prepared blossoms of another. My chief object in these experiments was to obtain such information as would enable me to calculate the probable effects of similar operations upon other species of plants; and I believe it would not be easy to suggest an experiment of cross-breeding upon this plant, of which I have not seen the result, through many successive generations. I shall therefore proceed to give a concise account of some of these experiments,

* See Horticultural Transactions, vol. v. page 234, Part IV.

or rather (as I wish not to occupy more than necessary of the time of the Society), to state the results of a few of them, believing that I shall be able to explain satisfactorily, the cause of a coloured variety of the Pea having been apparently changed into a white variety, by the immediate influence of the pollen in the experiment of Mr. Goss.

When, in my experiments, the pollen of a gray Pea was introduced into the prepared blossoms of a white variety, no change whatever took place in the form, or colour, or size, of the seeds; all were white, and externally quite similar to others which had been produced by the unmutated blossoms of the same plant. But these when sown in the following year, uniformly afforded plants with coloured leaves and stems, and purple flowers; and these produced gray peas only. When the stamens of the plants which sprang from such gray peas were extracted, and the pollen of a white variety, of permanent habits, was introduced, the seeds produced were uniformly gray; but many of these afforded plants with perfectly green leaves and stems, and with white flowers, succeeded, of course, by white seed. In these experiments the cotyledons of all the varieties of Peas employed or produced were yellow; and, consequently, the Peas with white seed-coats retained their ordinary colour, though they contained the plumules and cotyledons of coloured Pea plants. The cotyledons of the Blue Prussian Pea, which was the subject of Mr. Goss's experiments, are, on the contrary, blue; and the colour of these being perceptible through the semi-transparent seed-coats, occasioned those to appear blue, though they are really white; the whole habits of that plant are those of a white pea. The colour of the cotyledons only was, I therefore conceive, changed; whilst the seed-coats retained their primary degree of whiteness. I must consequently venture to conclude, that the opinions of Mr. Salisbury, quoted by Mr. Goss, which have also very long been mine, viz. that neither the colour of the seed-coats, nor the form, taste, or flavour of fruits, are ever affected by the immediate influence of the pollen of a plant of another variety or species, are well-founded.

I need not add, that Mr. Seton's experiment mentioned in the note to Mr. Goss's paper, is also most perfectly accurate; though the results differed from those obtained by Mr. Goss, owing, I imagine, to the greater permanence of colour in the cotyledons of the Green Imperial Pea, which was the subject of his experiments.

XXXIII. *Observations on the Effects of Age upon Fruit Trees of different Kinds; with an Account of some new Varieties of Nectarines. In a Letter to the Secretary. By THOMAS ANDREW KNIGHT, Esq. F.R.S. &c. President.**

MY DEAR SIR,

MANY *new varieties of fruits* of different species having been sent from my garden to the Horticultural Society in the last and in preceding seasons, and some others having been seen by you in the short visit which I had the pleasure to receive from you in the last autumn, I feel desirous to offer a few observations upon the expediency of obtaining such productions; or rather, upon the question, whether each variety have its period of youth, of maturity, and of old age, and be formed for a limited period of duration only; or whether each be capable of eternal propagation, with undiminished health and vigour.

The fact, that certain varieties of some species of fruits which have been long cultivated, cannot now be made to grow in the same soils, and under the same mode of management, which was a century ago perfectly successful, is placed beyond the reach of controversy. Every experiment which seemed to afford the slightest prospect of success, was tried by myself and others, to propagate the old varieties of the Apple and Pear, which formerly constituted the orchards of Herefordshire, without a single healthy or efficient tree having been obtained; and, I believe, all attempts to propagate those varieties have, during some years, wholly ceased to be made. I have detailed in the *Philosophical Transactions*†, an account of some experiments, which I repeated, with the hope of being able to ascertain which, amongst the various organs of trees of aged varieties, first fail to execute their proper functions; and I came to the conclusion, upon the following and other evidence, that it is the leaf. Having obtained by layers or cuttings, small plants of several of the most diseased of the old varieties of the Apple, these were grafted within a couple of inches of the surface of the soil with scions of new seedling and luxuriant varieties; and under these circumstances the roots of the most debilitated and diseased varieties executed their office perfectly well, and were found, upon examination, at the end of several years, wholly free from every symptom of disease. This process was reversed, and scions of old varieties were employed as grafts; but into the young growing

* From the *Transactions of the Horticultural Society*, vol. v. Part IV.

† For the year 1810, page 178.

shoots, which sprang from these, many buds of new and luxuriant varieties were inserted, and in the autumn every natural bud of the old varieties was destroyed. The inserted buds vegetated in the following spring, and by these efficient foliage was given; when every symptom of debility and disease disappeared, and the wood and bark of the most exhausted and diseased varieties now constitute a part of the stems of large apple trees, and present, at the end of thirty years, as much apparent health as other parts of the stems of those trees. From these results I have inferred, that the debility and diseases of such old varieties arise from the want of a properly prepared circulating fluid; and that when such is given by efficient foliage, the bark of the most debilitated variety possesses the power to occasion the necessary secretions to take place, and the alburnum is enabled to execute all its offices.

It has been urged against the conclusion, that old age is the cause of debility and decay of those varieties of fruit which have been very long cultivated, that many of the seedling offspring of such varieties are as much diseased as their parents; and it is contended, that the failure of our best old varieties of fruit has arisen from a succession of unfavourable seasons. The fact, that many of the seedling offspring of old diseased varieties of fruit are as much diseased as the parents from which they spring, is unquestionable; but this, I conceive, proves nothing more than that diseases are hereditary in the vegetable as they are in the animal world; and it is scarcely reasonable to expect that healthy and robust offspring can be obtained from parents, whose lives have been extended beyond their natural periods by preternatural means, and whose bodies are yearly falling to pieces under the operation of disease; and in which the whole of the circulating fluids are in a morbid state.

If a deterioration have taken place in our climate, and this have occasioned the decay of our fruit trees, at what period did this deterioration take place? It is more than forty years since I commenced experiments with the hope of being able to raise healthy trees of the old varieties of the Cider Fruits of Herefordshire; and I know that the progressive debility of those had been pointed out some years before my birth by my father, who died an old man when I was an infant; and who was an extremely competent judge of the subject.

Parkinson also, who lived in the reign of Elizabeth, complains of the unfavourable seasons in the latter part of his life. The grapes did not then ripen as they had formerly done; or more probably, I believe, he did not find them so sweet as he

thought them when he was a school-boy. That some change may, however, have taken place in our climate, owing to the operation of many concurrent causes, is not improbable, but not in a degree equivalent to the effects produced. Any considerable change of climate must also have affected alike the new and the old varieties of fruits, and the decay of the latter alone seems therefore to prove some constitutional change to have taken place in those.

If the leaf gradually fail to execute properly its office, a progressive degree of debility, preceding a state of disease and decay, must necessarily follow; and this I have noticed in some moderately old varieties of the Apple and Pear. They remain free from disease; they blossom frequently, and sometimes freely; but they rarely afford much fruit; and their recovery, from the exhausted state in which even a moderate crop of fruit leaves them, is very slow. If this state be induced, as I am well satisfied that it is, by the inefficient operation of the foliage, it becomes an interesting question at what period of the age of each variety such defective operation commences. The observations which I have had opportunities of making, lead me to believe that it commences at the period when the original tree becomes, according to the ordinary course of nature, debilitated by age; and I suspect that much the greater part of the varieties of fruit, of different species, which are now named in the catalogues of nurserymen, have already outlived the periods at which they best deserved the attention of the planter. This remark I wish particularly to apply to the Peach and Nectarine; varieties of which, of equal excellence and much superior vigour and hardiness, may be easily obtained from seeds ripened in the forcing-houses, if not upon the open walls, of our gardens. I sent to you, in the last autumn, many new varieties of Nectarines raised in my Peach-house from seeds of the Elruge and the pollen of the Early Violet Nectarine. They were the produce of buds inserted into the bearing branches of old Peach and Nectarine trees growing upon my walls, the original seedling trees not having been retained in my garden.

Every attention was paid to make the fruit from which the seeds were taken attain the highest state of perfection, and the crop of fruit of the trees which bore them, and from which the pollen was taken, was sacrificed almost wholly in the preceding season, that both those might be in the most efficient and vigorous state; and I preferred the forcing-house to the open wall, that the wood and blossoms might attain the most perfect state of maturity. Of the merits of the Nectarines you received, I wish to decline giving an opinion; and I shall therefore

therefore only remark, that in every unfavourable season, such as the last, the stones are always found larger, relatively to the bulk of the fruit, than in favourable seasons. But of the habits of the trees, or rather of the branches, (for few of the trees have been preserved,) I can speak with much satisfaction. The wood of many has ripened more perfectly, and offers a much stronger and more abundant blossom than is found on any of the branches of the parent varieties: and I feel perfectly confident that some of the new varieties, and particularly one of them, will succeed in forming blossoms, and ripening fruit in seasons and situations too cold for either of the old varieties from which they sprang.

Buds of any of the varieties, which you may think deserving culture, shall be sent in the proper season. Having preserved and given a place to the original tree upon my wall of one (which I believe you agreed with me in thinking the best, and to which you proposed to give the name of the Downton Nectarine) I shall be able to supply a much larger number of buds of that, than can be wanted.

I remain, my dear sir, sincerely yours,

Downton, Feb. 28, 1824.

THOMAS ANDREW KNIGHT.

Note by the Secretary.

April 17, 1824.—Mr. William Christie, the Fruit and Kitchen Gardener of the Society, having been at Downton during part of the last week, was much struck with the appearance of the blossoms of the new nectarines mentioned by the President in the above paper; they were particularly plump and strong, and their colour very bright and lively, all indicating vigour of constitution in the branches producing them.

XXXIV. *On the complete Solution of certain Functional Equations.* By JOHN HERAPATH, Esq.

LET us take the well-known equation

$$\psi x + fx. \psi ax = f_1 x \quad (1)$$

the conditions being $a^2 x = x$, $fx.fax = 1$, and $fx.f_1 ax = f_1 x$. Substituting $v\psi x + b\phi x$ for ψx wherein $v = 1$, and $b = 0$, ϕx being any arbitrary function, we have

$$v\psi x + b\phi x + \frac{\psi ax}{fax} = f_1 x. \quad (2)$$

Then changing x into ax , our conditions give

$$vfx.\psi ax + bfx.\phi ax + \psi x = f_1 ax.fx = f_1 x \quad (3)$$

and

and eliminating $\psi \alpha x$ between (2) and (3) there results after due reductions

$$\psi x = \frac{1}{2} f_1 x + C \{ \phi x - f x \cdot \phi \alpha x \} \quad (4)$$

C being an arbitrary constant which of course may be changed into an arbitrary symmetrical function of x and αx , or, which is the same, into such a function of x that it does not change by the substitution of αx for x . Let $^* \phi_1 x$ be such a function, then,

$$\psi x = \frac{1}{2} f_1 x + \phi x \cdot \phi_1 x - f x \cdot \phi \alpha x \cdot \phi_1 \alpha x. \quad (5)$$

Now since ϕ is perfectly arbitrary, it is evident that the limitation of ϕ_1 to symmetry does not prevent the product $\phi x \cdot \phi_1 x$ from being likewise perfectly arbitrary. Hence

$$\psi x = \frac{1}{2} f_1 x + \phi x - f x \cdot \phi \alpha x \quad (6)$$

is as general a solution as (5).

This indeed might easily have been deduced from (4) by including the constant C in the arbitrary function ϕ ; but I have chosen this train of argument for the sake of showing that the introduction of an arbitrary symmetrical function does not add to the generality of the solution.

Mr. Babbage has obtained the general solution of (1) in the Philosophical Transactions for 1817, under a more complicated form than (6) "by" what Mr. Herschel justly observes "a most singular and ingenious consideration." In Spence's Essays too, p. 163, Mr. Herschel has given for the complete solution

$$\psi x = \psi_1 x + \psi_2 x \cdot \tilde{\chi} \{ x, \alpha x \}$$

"where $\psi_1 x$ and $\psi_2 x$ are any particular solutions of the respective equations

$$\psi x + f x \cdot \psi \alpha x = f_1 x \text{ and } \psi x + f x \cdot \psi \alpha x = 0."$$

By taking

$$\psi_1 x = \frac{1}{2} f_1 x + x - \alpha x \text{ and } \psi_2 x = x - \alpha x.$$

Mr. Herschel's solution coincides with our (5) if $\phi x = x$. But if we compare the solution so obtained with our (6), we shall find the former much inferior in point of generality. For instance, Mr. Herschel's

$$\psi x = \frac{1}{2} f_1 x + \{ x - \alpha x \} \cdot \tilde{\chi} (x, \alpha x), \quad (7)$$

whose first term is the same as the first of ours. Supposing therefore this solution complete,

$$x \tilde{\chi} (x, \alpha x) > \phi x,$$

using the symbol $>$ to signify greater, and $<$ less generality. Of course also

$$\tilde{\chi} (x, \alpha x) > \frac{\phi x}{x},$$

* ϕ or $\tilde{\chi}$ is employed to signify a symmetrical function of what follows, for the convenience of the printer.

which

which is impossible. For $\tilde{\chi}$ being confined to symmetrical forms, $\tilde{\chi}\{x, \alpha x\}$ cannot comprehend unsymmetrical forms, nor therefore every function of x , however numerous the forms of $\tilde{\chi}$ may be; but ϕ being perfectly unlimited includes both symmetrical and unsymmetrical forms, or, in fact, any functional form whatever. Consequently $\frac{\phi x}{x}$ is much more general than $\tilde{\chi}(x, \alpha x)$, and hence (6) is more general than (7). It seems to me Mr. Herschell has fallen into error in the inference he has drawn at the end of p. 162 Spence's Essays. "Let Px and Qx ," says Mr. H., "represent any two particular solutions" of $\psi x = -\psi \alpha x$. Then we must have

$$\begin{aligned} Px &= -P\alpha x \\ Qx &= -Q\alpha x. \end{aligned}$$

Consequently $\frac{Px}{P\alpha x} = \frac{Qx}{Q\alpha x}$, and $Px = Qx \cdot \sqrt{\frac{Px \cdot P\alpha x}{xQ \cdot Q\alpha x}}$; and as this latter factor is a symmetrical function of $x, \alpha x$, it appears that the expression $Qx \cdot \tilde{\chi}\{x, \alpha x\}$ necessarily includes any other solution as Px ."

Now, if my views are right, this inference is much too general for the very limited condition of the premises. The true definition of a symmetrical function such as $\tilde{\chi}(x, \alpha x)$ appears to me to be, that the form of the function is variable and utterly independent of the form, relation, or change of the variables; and that these variables simultaneously circulate by a certain substitution made at the same time in each without any necessary relation of their values. In the factor

$\sqrt{\frac{Px \cdot P\alpha x}{Qx \cdot Q\alpha x}}$ however, which is equal to $\frac{Px}{Qx}$, neither of these conditions appears to have place. For the form of the function is invariable and dependent on the change of the variable, and the variables themselves Px, Qx , if they may be so called, do not change in magnitude or circulate, but simply change their signs; so that the property of a symmetrical function, namely, to retain the same value during the substitution, is here preserved by the quantities not changing their values but their signs; which change, too, is neutralized by the invariable and peculiar form of the function.

It may be asked, What is the complete solution of (1)? I have reason to believe that the very simple solution I have given is both a general and complete one, as well as the solutions given by Mr. Babbage in the Philosophical Transactions for 1817, and in the "Examples on the Calculus of Finite Differences, &c." p. 22, or perhaps any other that contains an arbitrary function of x and αx .

In general it appears, too, from ideas that have occurred to me, of which I may say more hereafter, that any equation, as

$$F\{x, \psi x, \psi \alpha x, \psi \alpha^2 x, \dots \psi \alpha^n x\} = 0$$

has n arbitrary functions, provided however that $\alpha^r x = x$ and $r > n$; and that an equation of the form

$$F\{x, \psi x, \psi^2 x, \dots \psi^n x\} = 0$$

has the same number. My ideas, however, on this subject are not sufficiently matured to enable me to speak confidently.

The method of substitution pursued in our solution of (1) which is taken from Mr. Babbage's solution of $\psi x = \psi \alpha x$, applies very successfully even in cases where it is introduced but partially. Thus in the equation

$$1 + fx\{\psi x + \psi \alpha x\} = \psi x \cdot \psi \alpha x \quad (8)$$

which Mr. Babbage has solved by a very neat process of differentiation and integration, but ultimately bringing out a transcendental solution, it may be applied partially to the evolution of an algebraic solution. By changing x into αx , we find that $fx = f\alpha x$ when $\alpha^2 x = x$, which is the condition of the problem. For ψx on the left side only of the equation substitute $v\psi x + b\phi x$, and equate the result with the same result, having x changed into αx ; and we shall find

$$\psi \alpha x = \psi x + \phi x - \phi \alpha x,$$

which substituted for $\psi \alpha x$ in (8) gives ultimately

$$\psi x = \frac{1}{2} \sqrt{(\phi x - \phi \alpha x)^2 + 4(fx^2 + 1)} + fx - \frac{1}{2}(\phi x - \phi \alpha x)$$

for the complete solution of (8).

Had we substituted for ψx on the right side only of (8), we should have found

$$\psi \alpha x = \frac{\phi \alpha x}{\phi x} \cdot \psi x$$

and therefore

$$\psi x = \frac{1}{2} \sqrt{\frac{4\phi x}{\phi \alpha x} + \left(\frac{\phi x}{\phi \alpha x} + 1\right)^2 fx^2} + \frac{fx}{2} \left(\frac{\phi x}{\phi \alpha x} + 1\right)$$

which is a solution equally general, but not so simple, as the preceding.

XXXV. *On the Specific Heat of the Gases.* By W. T. HAYCRAFT, Esq.*

THE experiments which I now submit to the Royal Society are repetitions of those I made many months ago, for the purpose of ascertaining the specific heats of the gases.

* From the Transactions of the Royal Society of Edinburgh, vol. x.

The importance of the subject so impressed my mind, that I determined to spare no pains in the prosecution of the inquiry, and therefore I willingly withheld my first experiments from the public eye, until, by a fresh series, I might present them with the greater confidence. The apparatus employed in these experiments was calculated to operate upon greater quantities of the gases than the former one, and as every precaution which had been suggested was adopted, they have, perhaps, given even more decisive results than the last. The results themselves, however, are in every important particular exactly the same. It is also but justice to myself to state, that the conclusions which the former experiments led to, were exactly the reverse of what I had anticipated, and that they seemed at the time totally opposed to the doctrines of Black and Crawford, which I am still disposed to credit to a limited degree.

Before I enter into the detail, it will be necessary to take notice of the modes in which former experimenters have proceeded in these inquiries, and to point out what I conceive to have been the sources of fallacy in some of their conclusions. Of all these modes, none were more elegant than that adopted by Professor Leslie; but as he himself states that their results were discordant with each other, it seems unnecessary to enter into a description of it. Dr. Crawford's method consisted of inclosing two different gases (previously exposed to muriate of lime, for the purpose of depriving them of their watery vapour,) in two close vessels of equal size and weight; these being heated to exactly the same temperature, by a very ingenious contrivance, were at the same time plunged into two vessels, containing water of a lower temperature: these vessels were also of the same size, form, and weight: then, by means of accurately adjusted thermometers, he ascertained the comparative rise of temperature occasioned by the two gases, and hence he determined their specific heats.

I know of no imperfection in this mode, excepting that the quantities of the gases were so small, that the results could not be obtained with sufficient accuracy.

This defect is entirely obviated by the method adopted by Messrs. De la Roche and Berard: their apparatus consisted of a column of water, so adjusted as to act with a constant and equal pressure in a close vessel containing air; which being gradually expelled by the superincumbent water, pressed on the outward surface of a bladder containing the gas whose capacity was to be examined. From this bladder the gas was propelled through the calorimeter: this consisted of a vessel containing water of a low temperature, through which a spiral

tube passed to conduct the gas. Previous, however, to its entering the calorimeter, the gas was heated, by a particular contrivance, to the boiling temperature. After leaving the calorimeter, it was conducted, by means of turn-cocks, into another bladder; the latter was acted upon in the same way as the former. By means of this reciprocating action, Messrs. De la Roche and Berard could cause 225.2 cubic inches of gas, heated to the boiling temperature, to pass through the calorimeter every minute. The temperature communicated was ascertained by a thermometer, and from comparative trials the capacity of the different gases was inferred.

This last method was superior to that of Dr. Crawford, inasmuch as greater quantities of gas could be employed. In other respects it was far inferior, because the experiments were not, strictly speaking, comparative. Atmospheric air, whose capacity was their standard of comparison, was subjected to trial, and the results were remarked. The other gases, at different periods, with the surrounding media of different temperatures, and under different barometrical pressures, were examined; this plan involved endless and very difficult calculations, in order to adjust those differences. But the greatest imperfection in those experiments, was the neglect of depriving the gases of their watery vapours previous to their examination. The apparatus itself would not admit of this, because the water employed in the process would necessarily keep the gas and the whole apparatus in a state of moisture. Besides, this very great source of error was materially increased by the high temperature to which the gases were exposed, being a condition in which they are disposed to unite with a greater quantity of watery vapour than at ordinary temperatures. Considering the subject in this point of view, therefore, the experiments of Messrs. De la Roche and Berard may be supposed to determine the capacities of the different gases united with watery vapour at the boiling point, but by no means of those gases in their dry state, and at ordinary temperatures.

The apparatus now to be described will perhaps be found to unite the advantages and avoid the defects of both methods.

It consisted of two hollow brass cylinders (see Plate II.), in each of which was a piston attached to a spindle by means of two levers of equal length; to the spindle was attached another lever, terminating in a handle, to be moved by an assistant. Each cylinder was closed at each end, excepting where the tubes were attached, which served to conduct the gases. By means of four valves to each cylinder, fixed in such a way as, though difficult to describe in writing, may be easily understood by reference to Plate II., *each* action of the piston forced

forced a quantity of air through the tubes; thus, by means of one additional valve, the apparatus would act upon exactly twice the quantity of air that could be acted upon in a pump of the ordinary construction.

The pipes immediately connected with the four valves terminated in two tubes; through one of which the air, during the action of the apparatus, was propelled with a constant and almost uniform current, while, through the other, the same air having passed through the heating apparatus and the calorimeter, returned to the cylinder, to be acted upon again in the same way. The heating apparatus just mentioned consisted of a metallic vessel, about 16 inches long, containing hot water, through which the tubes passed, containing the air propelled from the cylinders: those tubes traversed the heating vessel three times before their exit, more effectually to secure the gases arriving at the temperature of the water contained in the vessel. By means of a lamp placed under this vessel, I could raise the temperature of the water to any point required. This last arrangement, however, was rather a matter of convenience than necessity, as it will be easily perceived that, from the mode of conducting the experiments, a fixed point of temperature was not required.

There were also two calorimeters, similar in construction to those of Messrs. De la Roche and Berard before described. Each of these was connected with the tube containing the gas, propelled by its cylinders through the heating apparatus, and likewise with that through which the air flowed to the cylinder; these tubes were all of metal, and air-tight.

The apparatus, then, must be considered as consisting of two distinct parts, exactly the counterparts of each other, each conveying an equal quantity of gas through the same heating medium, but through separate calorimeters.

The tubes communicating between the heating vessel and the calorimeters were one inch in length. In these tubes there was an opening, through which could be introduced a delicate thermometer, for the purpose of ascertaining the temperature of the gases as they entered the calorimeters.

Each of the calorimeters was inclosed in a polished metallic case, for the purpose of preventing, as much as possible, the absorption or escape of caloric during the process. These latter were also placed in a box containing water, which was repeatedly agitated, that the calorimeters might not be affected by the unequal temperatures of the walls of the apartment.

For the purpose of facilitating the operation of filling the apparatus with the gas operated upon, there was a turn-cock fixed in the course of each returning tube, by which the cur-

rent of gas through the tube was interrupted. Two smaller turn-cocks also were fixed in the same tube, one on each side of the larger turn-cocks: these, when open, communicated with the external atmosphere. When, therefore, the large turn-cock was closed, and the small ones open, the air would necessarily, during the action of the machine, rush in at one of the small turn-cocks, and be forced out of the other, so that the air contained in the apparatus would be constantly renewed. In order, then, to fill the machine with the gas, nothing more was necessary than to form a connection between the gasometer or receiver containing the gas and the apparatus, by means of a tube connected to the small turn-cock first mentioned, through which the air rushed in. In performing this operation, however, I usually made use of an air-pump to exhaust the apparatus, and then opening the turn-cock communicating to the gasometer, filled it with the gas required: after this operation had been several times repeated, I found the gas contained in the machine to be nearly as pure as that contained in the gasometer.

By a slight consideration of this description of the apparatus, which may be deemed rather prolix, and by an inspection of the plate, it will be perceived that two gases, contained in the two parts of the machine, will be under circumstances precisely similar; the quantities of gas transmitted through the calorimeters in a given time will be the same; the temperature of the surrounding media and the barometrical pressure, will be equal; the temperature also of the gases themselves must be the same, because they passed through the same heating medium. In fine, the size of the tubes, cylinders, calorimeters and valves, was the same in the two parts of the machine.

Therefore, the temperature communicated by the two gases submitted to a comparative trial, will be the direct ratio of their comparative capacities for caloric, provided there be no disproportionate escape by absorption in the calorimeters, arising from the different temperatures of surrounding bodies.

This source of fallacy was obviated by the arrangement of Count Rumford, who contrived that the temperature of the surrounding medium should be as much above that of the calorimeter at the beginning, as it was lower at the end of the experiments.

The quantity of gas propelled through the calorimeter was 12 cubic inches during the action of the piston. Those actions, as regulated by a second pendulum, which was suspended in the apartment, being 120 every minute, the whole quantity would be 1440 cubic inches of gas propelled through the calorimeter

lorimeter every minute. There was no occasion, however, to take these quantities into the account, because they were precisely the same of each gas subjected to trial.

My thermometers were adjusted by Mr. Adie of Edinburgh. Each degree was divided into 5 parts, which were sufficiently large to be divided by the eye into 4 parts; so that the temperature could be ascertained to a 20th part of a degree, making allowance for the imperfection of all instruments. Each calorimeter was furnished with its thermometer, the bulb of which was placed equidistant from its four sides: two smaller ones were placed so as to ascertain the temperature of the gases before entering into or coming out of the calorimeter. One was attached to the heating vessel, and another to the vessel of water which served as the surrounding medium of the calorimeters.

Having filled both the calorimeters with water of the temperature of 42° , and the heating vessel with it at a temperature of about 180° , I admitted atmospheric air into each part of the apparatus. The pistons were put into motion, and continued till each of the calorimeters arrived at a temperature of 84° , with a variation of little more than one-twentieth part of a degree. Thus the temperature of the calorimeters was raised 42° each, with a correction of $\frac{1}{800}$ th part of the whole. Much greater allowances may very properly be made for the imperfections of the instruments. This experiment was designed to prove the accuracy of the apparatus, and was often repeated, at different periods, with the same event. I was assisted in the following experiments by my friend Dr. Clendinning, to whom I am much indebted for their success.

Experiments on Carbonic Acid.

No. 1.

The part of the apparatus which I call A was filled with carbonic acid, obtained from carbonate of lime; the part B with common air. In each of the cylinders was placed, in a proper receptacle, a quantity of very dry muriate of lime, for the purpose of perfectly freeing the gases from watery vapour. The calorimeters being filled with water at a temperature of 42° , and the heating vessels with water at $149^{\circ}\frac{1}{2}$, the following results were obtained.

Tem-

	Temperature of Calorimeter A, through which the Carbonic Acid passed.	Temperature of Calorimeter B, through which Atmospheric Air passed.	The comparative specific Heat of Carbonic Acid inferred from the comparative Rise of the Temperature of the Air being 10000.
At the beginning of experiment, }	42° Fahr.	42° Fahr.	
After 15 minutes, }	$68\frac{2}{20}$	$68\frac{16}{20}$	9730
		No. 2.	
At the beginning of experiment, }	$42\frac{1}{20}$	$42\frac{1}{20}$	
After 15 minutes, }	$66\frac{10}{20}$	$66\frac{14}{20}$	9919
		No. 3.	
At the beginning of experiment, }	42	42	
After 40 minutes, }	$71\frac{10}{20}$	$71\frac{8}{20}$	10035
		No. 4.	
At the beginning of experiment, }	45	45	
After 35 minutes, }	$68\frac{5}{20}$	$68\frac{4}{20}$	10021
		No. 5.	
At the beginning of experiment, }	$45\frac{14}{20}$	$45\frac{15}{20}$	
After 25 minutes, }	$63\frac{5}{20}$	$63\frac{6}{20}$	10000

In these experiments it will be perceived, that the two first indicate that carbonic acid has a less capacity for caloric than common air. The three last, however, which do not differ materially from each other, will indicate an equal capacity, if we take the average of their results. The cause of the two first experiments indicating a lesser capacity, I suppose to arise from the gas not being perfectly freed from watery vapours. In the experiments I made last year, I observed that it was necessary to expose this gas to the drying influence of muriate of lime, for 35 minutes at least before it indicated the same specific heat as atmospheric air. This is not the case with all the other gases: from hence I would infer, that it has a greater affinity with watery vapour.

The gas contained in the gasometer, as indicated by lime-water, contained 99 per cent. of carbonic acid; that taken from the apparatus after the experiments were concluded, by the same test, contained 90 per cent. The temperatures of the gases while entering the calorimeters were equal, as indicated by the thermometers. It is worthy of remark, however, that these temperatures appeared several degrees lower than that of the water contained in the heating apparatus through which they passed.

passed. This will be easily explained, when we consider that a thermometer can never indicate the true temperature of any gas or vapour, which is itself pervious to the radiation of heat or cold from surrounding bodies. On this account the thermometers indicated a temperature of the gases much lower than the true one, they being necessarily placed so near the calorimeters, which usually contained water of a temperature nearly 100° lower than that of the gases. In the same manner, the gases issuing from the calorimeters appeared to have a temperature something lower than that of the calorimeters themselves, being surrounded with objects of a lower temperature than that of the calorimeter.

Experiments on Oxygen Gas.

No. 1.

Having filled the part A with oxygen gas procured from the black oxide of manganese, and every arrangement being made as before, the following results were observed:

	Temperature of Calorimeter A, containing Oxygen Gas.	Of Calorimeter B, containing Atmospheric Air.	Inferred Capacities.
At the beginning of experiment, }	$45^{\circ}\frac{6}{20}$	$45^{\circ}\frac{5}{20}$	
After 5 minutes,	$61\frac{1}{2}\frac{6}{20}$	$61\frac{1}{2}\frac{5}{20}$	10000
After 10 minutes,	$67\frac{2}{20}$	$67\frac{1}{2}\frac{5}{20}$	10000
After 15 minutes,	71	$70\frac{1}{2}\frac{8}{20}$	10019
After 20 minutes,	$74\frac{9}{20}$	$74\frac{9}{20}$	9982

No. 2.

	A	B	
At the beginning of experiment, }	$56\cdot6^{\circ}$	$56\cdot4^{\circ}$	10000
In 10 minutes,	66·16	66·14	10000
In 15 minutes,	71	70·18	10000
In 20 minutes,	$74\frac{4}{20}$	$74\frac{2}{20}$	10000

The temperature of the gases entering the calorimeters was equal, being each 137° . The gas contained in the gasometer before the apparatus was filled, indicated 98° per cent. of oxygen, by the test of sulphuret of lime. After the experiment was concluded, that contained in the apparatus indicated 91° per cent.

[To be continued.]

XXXVI. *On Comparative Barometric Observations.*

By W. BURNEY, LL.D.

To the Editors of the Philosophical Magazine and Journal.

Gentlemen,

I HEREWITH inclose you the simple results of the Meteorological Table at the end of the Numbers of your Magazine and Journal, from the 25th of August 1823 to the 25th of August 1824, which are as follow :—

	Barom. Inches.	Therm.	Temp. of Sp. Water	Hygrom.	Evaporation. Inches.	Rain. Inches.
At Gosport	29.909	50°·12	50°·53	66°·1	28·86	37·17
In London	29·915	46 ·77	—	—	—	24·63
At Boston	29·652	47 ·80	—	—	—	25·28

I have taken the trouble to re-calculate these 12 months' observations, in order to ascertain the comparative results since the table was so far completed in August 1823, with the addition of rain caught in London and at Boston. Having devised the table in its present form, with a hope that it would be filled up at the other places with observations from a similar set of meteorological instruments to my own, I could wish to see it still more complete; and if it were possible for Messrs. Cary and Veall to register the state of the wind and the hygrometer at half-past 8 A.M., and the evaporation about every third morning at that time, it would add valuable information towards its completion. I shall have no objection to withdraw the daily state or names of the clouds, when they may think proper to make such additions, so that the whole may be comprised in the last page. Were the rain caught in Mr. Cary's pluviometer to be measured every day when it is measurable, it would certainly be more convenient for comparison. I shall not now make any remarks on the comparative results, but reserve the monthly averages till the end of the year.

With respect to the great difference in the amount of rain and the state of the barometers at Gosport and Boston in the Meteorological Table in the middle of last May, as pointed out by Mr. Squire in your last Number, page 155, the circumstance did not escape my notice at the time. But I was not surprised to find that the altitude of the mercury in Mr. Veall's barometer in the morning of the 14th of May, was $\frac{1}{2}$ of an inch more than in mine, or about $\frac{3}{10}$ of an inch higher than its annual comparative level with my barometer, having seen a still greater difference in his on the 1st of October,

tober 1823. I observed also that the mercury in Mr. Veall's barometer, and in Mr. Cary's, was pretty regular in its descent from the 9th to the 15th of May, and that it was a day later in arriving at the *minimum* pressure in that change than in mine. The conclusions I drew on these *phenomena* at the time, to satisfy myself of the probable accuracy of the Boston observations, were these:—I first considered the position of the wind here, which had blown very strong from the N.E. from the 9th to the 14th; also the latitude of Boston, which is upwards of two degrees north of Gosport, and thought that the difference of $3\frac{1}{4}$ inches depth of rain between Gosport and Boston, from the 9th to the 15th of May, would account satisfactorily for the greater altitude of the mercury in Mr. Veall's barometer, viz. $\frac{3}{10}$ of an inch more than its mean altitude in comparison of mine. If the wind, which accompanied this unprecedented fall of rain here, had blown from the north or west, the difference in the quantity of rain and the state of the barometer at Boston, would undoubtedly have been very different. Considering the position of the wind N.E., and the latitude of Boston, it is very probable that the rain-cloud was so much attenuated over the latter place, as to afford but little rain; for it sometimes happens in travelling that we see very awful thunder storms at a distance of 10 or 12 miles, while we enjoy a dry air with scarcely a cloud.

I believe it can be easily proved by calculation that *the precipitation of $3\frac{1}{4}$ inches depth of rain from the atmosphere*, is nearly equal to a depression of $\frac{3}{10}$ of an inch of mercury in the same place, or a rise of that quantity where the water is held in solution, as was the case at Boston.

The area of my pluviometer is 6 square inches, and the weight of $3\frac{1}{4}$ inches depth of rain in that square, allowing 20 ounces avoirdupois to a perpendicular inch, is 4lbs. 1oz. In the area of 6 square inches are contained 36 square inches, being the square of six, and by dividing 4lbs. 1oz. by 36, the quotient is 1oz. $14\frac{2}{3}$ drs. Assuming the pressure of the incumbent atmosphere to be 15 pounds weight upon every square inch of surface at the level of the sea, the following proportion may be adopted for ascertaining the additional pressure at Boston over that at Gosport on the 14th of last May, after an exhaustion of $3\frac{1}{4}$ inches of rain in the latter place more than in the former.

As 15lbs., the weight of the atmosphere on a square inch of surface, is to the mean altitude of the barometer, 30 inches; so is 1oz. $14\frac{2}{3}$ drs., to .24 inch of mercury, which is within .06 inch of what Mr. Veall's barometer indicated too much at that time. My barometer is fixed 50 feet above low-water mark.

It now remains for Messrs. Cary and Veall to make any ad-

ditional remarks on this subject that may have come within their notice, for the satisfaction of Mr. Squire.

I am, Gentlemen, your obedient servant,

Gosport, Sept. 16, 1824.

WILLIAM BURNNEY.

XXXVII. *On finding the exact Mean Solar Time.* By Mr. SAMUEL COOPER.

To the Editors of the Philosophical Magazine and Journal.

Gentlemen,

AS I have for some time been in the habit of making celestial observations for the purpose of ascertaining the rate of an excellent astronomical clock which shows mean solar time; for this purpose I have usually calculated the time from altitudes of the sun taken a few hours before or after noon, having the latitude and sun's declination given. Now my motive for troubling you on this subject is for the purpose of finding the *exact mean solar time*, that is, to the fraction of a second. In the first place I have my doubts whether I should use the *apparent* latitude, or that found by meridian altitudes of the sun taken with the reflecting circle on an artificial horizon corrected for semidiameter, refraction and parallax, or the same when reduced to that at the earth's centre. I shall here give an example for the purpose of more fully illustrating my meaning.

On August 25, 1824, at 28 minutes after 3 P.M. mean solar time according to the clock, and which I know to be near the true time, I found the visible altitude of the sun's lower limb to be $31^{\circ} 7' 34''.7$. Required the *mean solar time*, supposing the visible latitude of the place = $52^{\circ} 13' 30''$, or the reduced latitude $52^{\circ} 2' 37''$?

Solution.

First, for the visible latitude $52^{\circ} 13' 30''$	
Co. lat. $37^{\circ} 46' 30''$	l. sine = 9.7871502
Co. dec. $79 20 3$	l. sine = 9.9924313
Co. alt. $58 37 58$	_____
<u>175 44 31</u>	9.7795815
$87 52 15.5$	l. sine = 9.9997001
$-58 37 58$	
<u>29 14 17.5</u>	l. sine = 9.6888125
	9.6885126
	-9.7795815
	<u>2)9.9089311</u>
$25^{\circ} 46' 51''.8$	cos. = 9.9544655
	2
<u>51 38 43.6</u>	= $3^h 26^m 14^s.9$

Visible

Visible altitude of the sun's lower limb	=	31° 7' 34".7
Sun's semidiameter	=	15 51 .8
Sun's parallax in altitude	=	7 .2

		31 23 33 .7
Ref. corrected for bar ^r , ther ^r , &c.	= -	1 31 .7

		31 22 2
--	--	---------

True altitude of the sun's centre	=	58 37 58
-----------------------------------	---	----------

* As 360° : 51° 33' 43".6 :: 24^h - 16^s.3 : 3^h 26^m 12^s.6

Eq. of time at the instant of observation	=	1 47 .9
---	---	---------

Mean time	=	3 28 0.5
-----------	---	----------

Secondly. For the reduced latitude, the mean time by the above method of calculation is found equal to 3^h 28^m 34^s.4. So that it appears even in this instance there is a difference of 33^s.9, and in some cases it would be much greater; this is of material consequence where great accuracy is required, and therefore I must repeat that I should be much obliged to any of your scientific correspondents to inform me which latitude I must invariably use, and whether the process in the above solution is in every other respect perfectly correct for obtaining the requisite accuracy so much desired.

I remain, Gentlemen, with great respect,

Your obedient servant,

Pertenhall, Kimbolton,
Sept. 1, 1824.

SAMUEL COOPER.

P.S. Is the sun's right ascension as given in the Nautical Almanac, expressed in solar or sidereal time?

In using Dr. Tiarks's tables for finding mean solar time (given at pages 280 and 281 of vol. 62 of your Journal), should not the variation of the equation of time, in the interval of the sun's passing the meridian, and that of the star, be applied to the computation, when we wish to obtain the *exact* mean solar time?

XXXVIII. *Sketch of the Geographical Distribution of Plants in Yorkshire.* By J. ATKINSON, Esq. F.L.S. &c. Leeds†.

THE county of York, situate in parallel 53° and 54° N., is not less distinguished for its size than for its varied sur-

* I conceive this proportion necessary, because the solar days are not all accurately equal to 24 hours, but to 24^h ± the variation of the equation of time for that day.

† From the Memoirs of the Wernerian Society, p. 277, vol. v. part I.

face, possessing almost every variety of soil to be found from the level of the sea to the altitude of 2368 feet. Its Flora consists of about 1400 species, of which upwards of 600 are Phænogamous, the remainder Cryptogamous. They may be arranged under the following Natural Orders.

Alismaceæ . . . 15	Campanulaceæ . . . 6	Papaveraceæ . . . 8
Apocynæ . . . 2	Dipsacæ . . . 9	Polygoneæ . . . 12
Amaranthaceæ . . . 2	Ericæ . . . 11	Plantagineæ . . . 5
Amentaceæ . . . 31	Euphorbiaceæ . . . 9	Primulaceæ . . . 14
Amaryllideæ . . . 6	Filices . . . 28	Plumbagineæ . . . 1
Aroideæ . . . 6	Gramineæ . . . 65	Rhamnii . . . 3
Asphodelææ . . . 8	Gentianeæ . . . 9	Rubiaceæ . . . 11
Aristolochiæ . . . 1	Geraniæ . . . 14	Rosaceæ . . . 40
Aceræ . . . 2	Hypericinæ . . . 8	Ranunculaceæ . . . 28
Berberides . . . 1	Hydrocharideæ . . . 2	Solaneæ . . . 7
Boragineæ . . . 14	Irideæ . . . 2	Scrophularinæ . . . 24
Capparides . . . 5	Junceæ . . . 7	Smilacææ . . . 4
Cisti . . . 1	Lentibulariæ . . . 11	Saxifrageæ . . . 12
Cruciferæ . . . 34	Lycopodineæ . . . 5	Sempervivæ . . . 13
Cichoraceæ . . . 24	Leguminosæ . . . 44	Salicariæ . . . 2
Cynarocephalæ . . . 14	Labiataæ . . . 47	Thymelææ . . . 1
Corymbiferæ . . . 40	Malvaceæ . . . 5	Tiliaceæ . . . 1
Cyperaceæ . . . 34	Melanthaceæ . . . 1	Umbellifereæ . . . 36
Cucurbitaceæ . . . 1	Naiades . . . 12	Violææ . . . 8
Coniferæ . . . 1	Oleinæ . . . 2	Verbenaceæ . . . 1
Chenopodeæ . . . 13	Onagrariæ . . . 7	Musci . . . 200
Cacti . . . 4	Orobanchææ . . . 3	Lichenes . . . 207
Caryophylleæ . . . 37	Orchideæ . . . 18	Hepaticæ . . . 24
Caprifoliæ . . . 9	Portulacææ . . . 2	Algæ . . . 100
Convolvulaceæ . . . 4	Pedicularæ . . . 1	Fungi . . . 290

May not the general type of the vegetation of a country be considered as indicative of its geology?—Were the *Ericæ* ever found upon chalk or limestone?—Are not the following species always found upon these? *Chlora perfoliata*, *Astragalus glycyphyllos* and *hypoglottis*, *Neottia spiralis*, *Orchis pyramidalis*, *Cistus Helianthemum*, &c.? Is not *Arenaria verna* found on every lead-mine in England? Do not the *Pinguicula vulgaris*, *Vaccinium oxycoccos*, *Empetrum nigrum*, &c., indicate sandstone? Where can we find a single rare plant on alluvial soil?

Beginning at the Spurn, and following the coast of Yorkshire as far as Bridlington, and proceeding up the Humber to a little above Hull, including the whole of Holderness, the vale of York, and from South Cave to Selby, as well as part of the plain of Cleveland to the Tees, the whole country is composed of *alluvial* soil: here the botany presents nothing peculiar,

peculiar, having the same plants as the Lowlands of other parts of England. We no sooner cross the river Ouse, at Selby, than we approach an extensive *magnesian limestone* formation, extending across the county, from Doncaster, Ferrybridge, Kippax, Thorparch, Knaresborough by Rippon, to the county of Durham: this district is rich in botany. At Kippax may be found, in about a square mile, *Orchis Morio, mascula, ustulata, militaris, pyramidalis, maculata, conopsea*; *Habenaria viridis*; *Ophrys apifera, muscifera*; *Neottia spiralis*; *Listera ovata*; *Allium arenarium, oleraceum*; *Anthyllis vulneraria*; *As-tragalus glycyphyllos, hypoglottis*; *Carlina vulgaris*; *Cerastium arvense*; *Chironia Centaureum*; *Chlora perfoliata*; *Cistus Helianthemum*; *Colchicum autumnale*; *Daphne laureola*; *Erigeron acre*; *Galeopsis versicolor*; *Gentiana amarella*; *Hedysarum onobrychis*; *Ornithogalum umbellatum*; *Potentilla verna*; *Rhamnus catharticus*; *Sanguisorba officinalis*; *Sedum telephium*; *Pimpinella magna*; *Antirrhinum minus*; *Circaea lutetiana*; *Campanula glomerata, latifolia*; *Caucalis daucoides*; *Parnassia palustris*, &c. &c. Throughout the whole of this district, most of the above plants are to be found more or less abundant. At Thorparch a few rare ones may be added: such as, *Anemone pulsatilla*; *Silene noctiflora*; *Galium tricorne*; *Asperula cynanchica*; *Narcissus biflorus*; *Pyrus aria*; *Epipactis Nidus avis*; *Actæa spicata*; *Melica nutans*; *Cichorium Intybus*; *Carduus eriophorus*; *Atropa Belladonna*; *Ophrys aranifera*? and *apifera*; *Ornithogalum luteum*, &c. &c. About Knaresborough, *Chara flexilis, hispida*; *Dipsacus pilosus*; *Geranium sanguineum*; *Lepidium latifolium*; *Silene nutans*; *Helleborus viridis*, &c. Passing over this limestone, which may extend about 10 miles in breadth, from Selby, we approach Leeds; the immediate vicinity of which is all clay. A few plants, not very common, may be found towards Knostrop, near the river Aire, such as, *Sisymbrium sylvestre*; *Cardanime amara*; *Stellaria nemorum* and *Hottonia palustris*. Passing Leeds, to the north, the sandstone formation begins. (It contains, in the neighbourhood of Bramley, Woodhouse, Chapelton, &c. many organic remains of vegetables: we have noble specimens of the *Phytolithus verrucosus, parmatus, stellatus, striaticulmis, sulciculmis, cancellatus, imbricatus, and tessellatus*.) The sandstone formation occupies an extensive district, by Otley, as far as Greenhow Hill, where it meets the compact limestone: it then passes south, forming a range of alpine moors, by Ilkley, Keighley, and Halifax, to meet the range of the like formation dividing Yorkshire from Lancashire. Many of these heaths are of considerable elevation, as, Bardon Fell, 1663 feet; Draughton Moor, 1074 feet; Foxstone's Moor, 1513 feet; Otley Chevin, 921 feet;

921 feet; Cow Rock, Rumbles Moor, 860 feet. The rarer plants are, *Botrychium Lunaria*; *Osmunda regalis*; *Polypodium phegopteris*, *dryopteris*; *Aspidium oreopteris*, *aculeatum*, *lobatum*, *dilatatum*; *Asplenium viride*, *trichomanes*, *Adiantum nigrum*, *Ruta muraria*, *Blechnum boreale*, *Pteris crispa*, *Cyathea fragilis*, *Hymenophyllum tunbridgense*, and 80 *Musci*, all near Halifax: *Veronica montana*, *Scandix odorata*, *Narcissus pseudo-Narcissus*, *Pyrola media* and *minor*, *Prunus padus*, *Rubus idæus*, *chamæmorus*; *Trollius europæus*, *Geranium pyrenaicum*, *Epipactis latifolia*, *Crocus nudiflorus*, &c.

The moors, in general, are clothed with the three species of Heath: the *Empetrum nigrum*, *Vaccinium oxycoccos*, and *Vitis idæa* are also common; the more elevated parts furnishing the *Rubus chamæmorus*, *saxatilis*, *Lycopodium clavatum*, *selago*, *alpinum*; and, at the highest part, *Arbutus uva ursi*.

Retracing our steps to Greenhow Hill, and proceeding north-west, we come to the mountain district of Craven, chiefly consisting of compact limestone. Here we are presented with many most magnificent scenes, equally pleasing to the lover of landscape and to the botanist. The rocks at Gordale Scar and Malham Cove, rising several hundred feet perpendicular, are probably not to be equalled in England. The mountains are of great elevation; Ingleborough, 2368 feet; Pennigent, 2281 feet; Great Whernside, 2309 feet; West Simon-Seat, 1593 feet; Beamsley Rock, 1310 feet; Spode Hill Bank, 1223 feet; Sutton Crag, 1161 feet. Many of the summits of the higher parts of these mountains are covered with sandstone, producing ling and other plants common on that soil. The undisturbed woods, particularly about Bolton Abbey, afford a rich harvest for the botanist. Here trees of great age and immense magnitude may be seen literally covered with a profusion of cryptogamous plants, resembling a garden in miniature; Lichens hang in festoons from the branches, whilst the bark is hidden from view by innumerable mosses, on which vegetate *Hepaticæ* and *Filices*. The plants upon or near Ingleborough are, *Rubus chamæmorus*, *Actæa spicata*, *Sedum villosum*, *Sesleria cærulea*, *Poa glauca*, *Festuca vivipara*, *Primula farinosa*, *Polemonium cæruleum*, *Ophrys cordata*, *Scrapias longifolia*, *Rhodiola rosea*, *Convallaria Polygonatum*, *Saxifraga stellaris*, *oppositifolia*; *Thalictrum minus*, *Draba muralis*, *Thlaspi arvense*, *Cochlearia officinalis*, *Geranium sylvaticum*, *sanguineum*; *Gnaphalium dioicum*, *Solida virgo aurea* γ , *Serapias ensifolia* and *rubra*. In the district are found, *Chara hispida*, *Galium boreale*, *Viola lutea*, *Gentiana campestris*, *Ornithogalum luteum*, *Convallaria multiflora*, *Epilobium alpinum*, *Polygonum viviparum*, *Saxifraga aizoides*, *hypnoides*, *Stellaria nemorum*, *Arenaria verna*, *Potentilla*

tentilla aurea, *Geum rivale*, *Dryas octopetala*, *Actæa spicata*, *Thalictrum minus*, *majus*, *Trollius europæus*, *Draba incana*, *muralis*, *Thlaspi alpestre*, *Cochlearia officinalis*, *Cardamine impatiens*, *Turritis hirsuta*, *Geranium phæum*, *sylvaticum*, *sanguineum*, *Hieracium paludosum*, *Hypochæris maculata*, *Carduus heterophyllus*, *Senecio sarracenicus*, *Satyrium albidum*, *Ophrys nidus avis*, *Cypripedium Calceolus*, *Salix myrsinites*, *herbacea*, *reticulata*; *Taxus baccata*, *Osmunda lunaria*, *Lycopodium selaginoides*, *inundatum*, *alpinum*; *Asplenium viride*, *Scolopendrium ceterach*, *Pteris crispa*, *Hymenophyllum tunbridgense*, &c.

The high range of hills called the Yorkshire Wolds, beginning at the coast near Bridlington, is composed of chalk. This formation extends by Driffield, forming a bow betwixt Beverley and Pocklington to the Humber. In this part the *Ericæ* are not found. The only rare plants are a few common to limestone, viz. *Festuca pumilis*, *bromoides*, *Gentiana amarella* β , *Chlora perfoliata*, *Astragalus hypoglottis*. Passing the Vale of Pickering (lately rendered notorious by the fossil bones discovered in the Kirkdale Cave), we come to the oolite, extending from Scarborough, by Kirkby Moorside, Hemsley, to meet the alluvium near Easingwold; it then takes a turn to the east, and passes Malton, and we find on it the following plants; *Chara hispida*, *flexilis*, *Veronica montana*, *Utricularia minor*, *Schænus mariscus albus*, *Scirpus pauciflorus*, *articularis*, *sylvaticus*, *Bromus pinnatus*, *Arundo epigejos*, *calamagrostis*, *Lolium arvense*, *Elymus europæus*, *Galium tricorne*, *Potamogeton gramineum*, *Viola hirta*, *lutea*, *Gentiana pneumonanthe*, *Bupleurum rotundifolium*, *Caucalis daucoides*, *Pimpinella magna*, *Linum perenne*, *Drosera anglica*, *longifolia*, *Paris quadrifolia*, *Pyrola rotundifolia*, *Potentilla verna*, *Geum rivale*, *Papaver hybridum*, *Ranunculus Lingua*, *parviflorus*, &c.

The only district which I have not been able to examine is the Alum-shale, rising on the coast, from Whitby to the Tees, including the Vale of Esk. The small line of basalt found in Yorkshire passes through the above.

Plants found in the southern counties of England, which are not in Yorkshire:

<i>Clematis vitalba</i> .	<i>Campanula patula</i> .
<i>Orobanche minor</i> .	<i>Trachelium</i> .
<i>Tamarix gallica</i> .	

Northern plants, not found:

<i>Ligusticum scoticum</i> .	<i>Aira levigata</i> .
<i>Cerastium tetrandrum</i> .	<i>Sagina maritima</i> .

Plants which appear to have reached their northern limits:

<i>Butomus umbellatus</i> .	<i>Viscum album</i> .
-----------------------------	-----------------------

Plants

Plants which appear to have reached their southern limits:

Trientalis europæa.

Native Swiss plants found in Yorkshire:

<i>Malaxis paludosa.</i>	<i>Impatiens noli tangere.</i>
<i>Cistus marifolius.</i>	<i>Arenaria verna.</i>
<i>Geum rivale.</i>	<i>Campanula latifolia.</i>
<i>Ribes petreum.</i>	<i>Thlaspi alpestre.</i>
<i>Thalictrum majus.</i>	<i>Solidago virgaurea.</i>
<i>Sedum villosum.</i>	<i>Ornithogalum luteum.</i>
<i>Epilobium alpinum.</i>	<i>Melica nutans.</i>
<i>Pyrus aria.</i>	<i>Sedum Telephium.</i>
<i>Pyrola rotundifolia.</i>	<i>Allium arenarium.</i>
<i>minor.</i>	<i>Convallaria majalis.</i>
<i>Stellaria nemorum.</i>	<i>Fumaria claviculata.</i>
<i>Geranium lucidum.</i>	<i>Thalictrum minus.</i>
<i>sanguineum.</i>	<i>Astragalus hypoglottis.</i>
<i>Gentiana pneumonanthe.</i>	<i>Lepidium latifolium.</i>
<i>Osmunda regalis.</i>	

Rare plants, natives of Lapland and Yorkshire:

<i>Rubus chamæmorus.</i>	<i>Salix rosmarinifolia.</i>
<i>Draba incana.</i>	<i>Thalictrum alpinum.</i>
<i>Rhodiola rosea.</i>	<i>Andromeda polifolia.</i>
<i>Tofieldia palustris.</i>	

Rare plants, natives of Switzerland and Yorkshire:

<i>Cerastium alpinum.</i>	<i>Serratula alpina.</i>
<i>Potentilla aurea.</i>	<i>Dryas octopetala.</i>
<i>Bartsia alpina.</i>	<i>Aspidium lonchitis.</i>
<i>Gentiana verna.</i>	<i>Polygonum viviparum.</i>
<i>Viola lutea.</i>	<i>Saxifraga stellaris.</i>
<i>Salix herbacea.</i>	<i>aizoides.</i>
<i>Galium boreale.</i>	<i>Equisetum hyemale.</i>
<i>Lathræa squamaria.</i>	<i>Scandix odorata.</i>
<i>Rubus idæus.</i>	<i>Ribes alpinum.</i>
<i>saxatilis.</i>	<i>Asplenium viride.</i>
<i>Trientalis europæa.</i>	<i>Cirçæa alpina.</i>
<i>Salix pentandra.</i>	<i>Epilobium angustifolium.</i>
<i>Ophrys cordata.</i>	<i>Narthecium ossifragum.</i>

Rare plants, natives of Lapland, Switzerland, and Yorkshire:

<i>Papaver cambricum.</i>	<i>Bartramia arcuata.</i>
<i>Salix Croweana.</i>	<i>Asplenium adiantum nigrum.</i>
<i>Alisma natans.</i>	<i>Hymenophyllum tunbridgense,</i>
<i>Scolopendrium Ceterach.</i>	&c.

Plants indicative of great altitude:

Arbutus uva ursi.

Hutchin Moor, near Todmorden . . . Yorkshire.

Cronkley

Cronkley Fell	Yorkshire.
Kinder Scout	Derbyshire.
Dale Head	Westmorland.
Near Hexham	Northumberland.
Martindale, Dale Head	Cumberland.

Saxifraga oppositifolia.

Ingleborough, Hinklehaugh, and Malham Cove	Yorkshire.
Cader Idris, and other high mountains in	Wales.
In a ravine of the Screes, near Wastwater	Cumberland.

Rubus Chamæmorus.

Ingleborough, Hinklehaugh, Kirby Fell, &c.	Yorkshire.
Mountains of Wales, Westmorland, Cumberland, and Durham.	

Plants extremely local.

Dryas octopetala.—On Arncliffe, Clowder, in Littendale; and near Settle, Yorkshire; and Cronkley Fell*.

Gentiana verna.—Found in Teesdale in most surprising quantities, and, luckily, cannot be extirpated, in consequence of its sending out innumerable runners, each of which becomes a plant on digging up specimens. Gardeners from all parts of England have visited this spot, and attempted its destruction, after removing quantities for sale.—Goths indeed!

Cypripedium Calceolus.—In several parts of Craven, Yorkshire; Castle Eden Dean, Durham; Borough Hall Park, Lancashire.

The Ladies' Slipper used to be found in tolerable plenty about Ingleborough; the greediness of florists has, however, rendered it scarce. The great secret in its cultivation appears to be rest. A poor man in Craven has made a considerable sum annually by the sale of this plant: he possesses a small garden surrounded with gooseberry trees; in the centre, he planted some years ago some plants of the *Cypripedium Calceolus*; they were left undisturbed for a long period, and have filled the garden, flowering freely, and flourishing under the partial shade of the gooseberry-bushes.

Leeds, Oct. 1823.

* Cronkley Fell is often cited as in Durham, but certainly on the York side of the Tees.

XXXIX. *Notices respecting New Books.*

Meteorological Essays and Observations, by J. F. DANIELL,
F.R.S. London 1823. 8vo. pp. 464.

[We have been induced to republish the following review of Mr. Daniell's *Meteorological Essays*, from an American periodical publication in which it has very recently appeared, not only as a very clear and concise analysis of the work in question, but also as it may not be unserviceable in showing the attention and intelligence with which the progress of science in this country is viewed on the other side of the Atlantic.—We have been informed that the article is understood to be from the pen of Professor Renwick of Columbia College in New York:]

THE atmosphere that surrounds the globe we inhabit is the scene of numerous and important phenomena. With these our comfort and health is most intimately connected; and yet, although they take place in our immediate vicinity, and are continually producing marked effects upon our senses, we are much less acquainted with the laws that govern them, than we are with those that direct and regulate the motions of bodies situated at distances from us so remote as almost to baffle human conception. Yet this is not because a sufficient degree of attention is not paid to the changes that occur in the atmosphere; for they form an object of constant observation and remark to all classes of mankind; but our ignorance arises from the want of regular and correct registers of the more obvious appearances, and of instruments by which the more hidden phenomena may be discovered and observed. This last defect bids fair to be soon obviated. The labours of several powerful minds have of late years been devoted to the science of meteorology. Much has been thus accomplished in the discovery of causes that affect climate, and in the contrivance of instruments to observe and register them; but by far the most important work that has yet appeared on this subject is that of Daniell. We shall endeavour to give our readers an analysis of this interesting volume.

The earth, as is well known, is surrounded by an atmosphere, whose principal constituent part is a permanently elastic fluid, that may, as far as its effects upon climate are concerned, be considered as homogeneous. The temperature of this, at any point of the earth's surface, may be observed by means of a thermometer, and its mechanical pressure by the barometer. These instruments are so familiar as to need no description; their use and construction are both well known to all persons
pretending

pretending to the appellation of scientific. It may not, however, be irrelevant to remark, that no standard thermometer is known to exist; and that most barometers are carelessly made, and filled with mercury from which the air has not been sufficiently extracted.

Were the earth a sphere of uniform temperature, and at rest in space*; its atmosphere a perfectly dry and permanently elastic fluid; the height of the latter would be constant over every point of the earth's surface, and its density and elasticity, at equal elevations, every where the same. The column of mercury that it would support in the barometer, would therefore be the same at every point on the surface of the sphere; and equal at equal heights above the surface. The atmosphere would be absolutely at rest; and as its elasticity is proportioned to the pressure, the density would decrease in geometrical progression, while the distance from the surface of the sphere increases in arithmetical. When air is rarefied, its capacity for heat is increased, and *vice versa*; the sensible heat of the atmosphere must, therefore, decrease as the altitude increases; and as this changes the volume of elastic fluids, even under equal pressures, the barometer alone will no longer be the exact measure of the progressive density, but must be associated with the thermometer. Any change of temperature that affects every part of the sphere, would cause an increase in the elasticity of the atmosphere, and in its consequent height, without producing any motion in the lateral direction, or any change in the pressure upon the surface; but the pressure will be changed at all other altitudes.

If the temperature of the sphere, instead of being equal at every point, were greatest at the equator, and decreased towards the poles, the pressure on every point of the surface would still continue the same; but the altitude of the atmospheric column would become greatest at the equator, and its specific gravity at the surface less there than at the poles. The heavier fluid at the poles must, by its mechanical action, press upon and displace the lighter, and a current will be established in the lower part of the atmosphere from the poles towards the equator. The difference in the specific gravity of the polar and equatorial columns becomes less as we ascend into the atmosphere; while the elasticity, which is constant at the surface, varies with the height, and the barometer stands higher at equal elevations in the equatorial than in the polar column. It will hence happen, that, at some definite height, the unequal density of the lower strata will be compensated; and a counter-current will take place in the higher regions

* Essay 1st, part 1st.

from the equator towards the poles. Our author has investigated the height at which this would happen, under certain circumstances, and calculated the velocity of each current at different elevations. The velocity and direction of these currents may be affected by the partial rarefaction or condensation of any of the columns; and such change of density will naturally take place, in consequence of the vicissitudes of the seasons, and the alternations of day and night.

If the sphere be set in motion, and made to revolve around its polar diameter, as an axis, an apparent modification will take place in the direction of the currents. The lower current, coming from a point whose velocity of rotation is less than that at which it arrives, will appear to be affected with a motion, in a direction contrary to that of the revolution of the sphere; while the upper current, being under opposite circumstances, will be apparently affected in an opposite manner. Hence we find, in the equatorial regions of the earth, winds that blow continually from N.E. on the northern side of the equator, and from the S.E. on the southern. In this region, the temperature is subject to little variation, and the general causes that have been described are more powerful than the local action; but, as slight irregularities of temperature are capable of producing great disturbances, that would act unequally on the antagonist currents, accumulations in some parts, and consequent deficiencies would arise, and cause temporary and variable winds, that in the higher latitudes would modify the regular currents, and often reverse their courses.

The atmosphere is not composed entirely of a homogeneous and permanently elastic fluid, but always contains a considerable portion of aqueous matter. It has been supposed by some that this is chemically combined with the air; by others, that it exists there in the form of vapour. The experiments of Dalton have established, conclusively, that the latter is the true theory; and that every given portion of space is capable of containing, at a given temperature, a certain amount of aqueous vapour, whether there be air present, or not. Mr. Daniell proceeds, in the second part of his first essay, to investigate the phenomena of an atmosphere composed entirely of aqueous vapour; and the third part treats of one composed of permanently elastic and condensable fluids mixed. It would occupy too much space to follow him in this most ingenious and interesting inquiry; we shall therefore content ourselves with stating, in his own language, the results at which he arrives.

“The specific gravity and elasticity of the air is but slightly affected by this intermixture of aqueous vapour; so slightly, indeed,

indeed, that the course and velocity of the currents may be considered, without any chance of disturbing our main argument, as unaltered. It will also be remarked, that while the great aerial ocean is divided into two distinct strata, flowing in opposite directions from south to north, the aqueous part, which is nearly confined to the lower current, presses in a contrary direction. The adjustment of these particulars remaining as now supposed, the compensating winds flow on in the courses which have been described, and the balance remains undisturbed."

Although the general currents are so little affected by the mere presence of aqueous vapour, the variations of temperature that are produced by its evaporation and condensation will tend to produce changes in their direction; these will be of great importance, but modified by local circumstances. The surface of the earth is not uniformly composed of one substance, but is partly covered by land, and partly by water. The evaporation from surfaces of these two different natures will be very different, and the changes of temperature arising from this source must vary with every modification of local circumstances. The quantity of moisture, then, that the air of any particular place contains, will have an influence upon its climate; nor can any set of meteorological observations be complete, when this is not employed as an element. The increase of weight acquired by deliquescent salts, the tension of cords, the shortening of whalebone, hair, and of some vegetable substances, have all been applied to this purpose, but with little success. Aware of the great importance of this subject, Mr. Daniell has planned and constructed a hygrometer that must, when its merits shall be fairly appreciated, supersede all others. Hygrometers, constructed of the substances we have already mentioned, indicate merely the presence of different portions of vapour, without affording any means of determining its absolute quantity. Leslie has indeed proposed a modification of his differential thermometer as a hygrometer; and observations with this may be applied to the tables of vapour existing in space at a given temperature, as deduced from the experiments of Dalton; but his instrument, although beautiful and ingenious in the highest degree, is liable to objections from which Mr. Daniell's is free. It requires abstruse calculations, and delicate corrections, on the nature of which philosophers are by no means agreed; and it has the disadvantage of having an arbitrary scale, instead of adopting one of those sanctioned by usage in the common thermometer.

If a vessel containing a cold liquid be exposed to air of a temperature considerably higher, it will be covered with a film of condensed

condensed vapour, whose quantity will depend partly upon the moisture existing in the atmosphere, and partly upon the difference in sensible heat between the air and the liquid in the vessel. There are certain saline substances that lower the temperature of the water in which they are dissolved; if one of these, in fine powder, be added gradually to a portion of water contained in a vessel, the temperature may be lowered by slow degrees, until it reach that point at which deposition will just begin to take place. A thermometer placed in the liquid will show this temperature, and mark the degree of heat at which saturation would occur, with the quantity of moisture then contained in a given bulk of atmospheric air. This degree of the thermometer is called the dew point, and will, by mere reference to tables deduced from the experiments of Dalton, give the absolute quantity of moisture that is present.

This experiment would be attended with some difficulty in practice. Mr. Daniell has therefore adopted another method of performing it. If water be placed in one of two balls, connected together by a tube bent twice at right angles and exhausted of air, the immersion of the empty ball in a freezing mixture will cause the congelation of the water contained in the other; for the aqueous vapour that rises rapidly *in vacuo* will be as rapidly condensed by the cold application; its place will be supplied by a fresh evaporation from the surface of the water, and the formation of this new vapour will carry off so much heat from the mass, as rapidly to reduce its temperature to the freezing point. If ether be substituted for water in the balls, and if the ball that contains no liquid be coated with a bibulous substance, moistened also with ether, the evaporation of this last will produce a great degree of cold; and this will not be manifested in the loss of heat by the ball to which the ether is applied, but by the rapid passage of the inclosed ether in the state of vapour from the other bulb, the temperature of which is lowered in consequence. The loss of temperature in the naked bulb may be rendered evident by inclosing within it, and the contiguous stem, a very delicate thermometer; as soon as the surface of this bulb is cooled down to the point at which the aqueous matter contained in the atmosphere would be precipitated, it becomes clouded with a thin film of moisture; a practised eye will readily seize the precise instant at which this takes place, and will at the same moment read the temperature shown by the included thermometer. In the whole circle of physical science there is no instrument more simple and beautiful in principle than this hygrometer. Its use is not attended with any difficulties; and it fully satisfies all the conditions laid down by Saussure, as essential to the perfection of
hygrometric

hygrometric instruments. Did it furnish us only with an easy and certain method of ascertaining the quantity of moisture present, at any given time, in the atmosphere, it would be of the utmost importance in keeping registers of the weather, with a view of comparing the climate of different countries, and seeking for those causes of atmospheric phænomena which are yet hidden; and it would, when joined to observations of the barometer, furnish the most certain indications of the probable state of the weather, so important to those engaged in many of the active pursuits of life. But in addition, it gives us a measure of the force and quantity of evaporation; a question that has never yet received a satisfactory solution; and which, when settled, could at once be applied advantageously to many practical cases; and it supplies the desideratum that has hitherto prevented the complete success of the barometric measurement of heights.

It is to be recorded, to the disgrace of European science, that this instrument, so simple in theory, and so beautiful in its practical application, has, from causes of local jealousy, not yet received the notice and distinguished approbation to which it is entitled. In Edinburgh, Professor Leslie, bigoted to his own inventions, and full of his views of applying his differential thermometer to this, among a variety of other uses, has, in his article on meteorology, in the supplement to the *Encyclopedia Britannica*, entirely passed over the invention of Mr. Daniell; and, after stating casually the principle on which it is founded, contented himself with saying, that it might be of value could it be "easily and nicely reduced to practice." In Switzerland, the editors of the *Bibliothèque Universelle* affect to think that Mr. Daniell could not have been acquainted with Saussure's hygrometer, or he would not have thought it necessary to construct a new one; although Saussure's papers may be quoted as the evidence of the imperfections of his own instrument. The philosophers of France; with a blindness of national prejudice, almost equal to that manifested by the mathematicians of England, when, for a quarter of a century, they disdained to profit by the brilliant inventions of Laplace and Lagrange, have passed Mr. Daniell and his discoveries without notice; while in London he has to contend with the whole weight and influence of the President and Council of the Royal Society, in consequence of his having pointed out the extreme negligence with which the meteorological register, published under the sanction of their authority, was kept. Mr. Daniell has, however, had the good fortune to meet with a coadjutor in his interesting experiments, who, for scientific acquirements, and skill as an observer, ranks second

cond to none at present living. The name of Captain Sabine is so well known among us, that it is sufficient to mention it, in order to enable our readers to appreciate the great value of his aid and zealous support to our author. His communications form a considerable portion of the volume before us, and have all that clearness of detail, and philosophical precision, for which his papers in the Transactions of the Royal Society of London are so remarkable.

The Third Essay is upon the subject of the radiation of heat in the atmosphere. We have already devoted so much space to the preceding topics, that we can only state a few of the most important facts that are there detailed. It is shown, conclusively, from a comparison of observations, under the equator, in temperate climates, and within the arctic circle, that the excess of the heat derived from the direct rays of the sun, above the temperature of the air, is much greater in high than in low latitudes. This is evidently a most bountiful provision of Providence, in equalizing the effect of different climates, and fitting them all to be inhabited by the human race. We may in this way account for the facts, that the hottest days in high latitudes are nearly as oppressive to the mere senses, as in low latitudes, where the thermometer stands much higher; and that vegetation is so very rapid in cold countries after the ice and snow are dissipated. Mr. Daniell has given a very ingenious hypothesis, by which he accounts for this curious phenomenon. The air, as we have seen, exerts a pressure on every part of the earth that, taken at a mean, is equal; in high latitudes, however, the air is the most dense, and the atmosphere assumes in consequence the figure of a spheroid very much flattened towards the poles. Our author supposes that the depth of this atmosphere, at each particular place, has an influence on the quantity of heat that is transmitted.

The heat that is communicated by the sun to the earth again radiates; the rate of radiation will be affected by a variety of circumstances, such as the presence or absence of the sun, the temperature of the radiating surface, and the state of the heavens. Dr. Wells, it may be mentioned, has made a most important use of this subject in explaining the formation of dew. Mr. Daniell finds, that radiation from the earth follows the same law as the direct radiation from the sun, being proportionably less in low than it is in high latitudes; and he applies the same explanation to this as to the other circumstance. He lastly details an experiment by which he shows, most conclusively, not only that the rays of the moon do not communicate any sensible heat, but that its light does not affect the terrestrial radiation, even as much as the slight cloud that hardly ob-
scures

scures its illuminated surface. We state this result, inasmuch as it completely disproves the reasoning founded on a late experiment made in this country, by which it was attempted to be shown, that the lunar light was capable of affecting a very sensible differential thermometer.

Besides the irregular fluctuations in the altitude of the barometer, a patient and careful investigation shows that there is a horary oscillation*, apparently produced by tides in the atmosphere. By a series of observations, at seven different stations, one extreme being under the equator, and the other in 50 degrees north latitude, it appears, that while the irregular movement of the atmosphere and general range of the barometer increase, in going from the equator towards the fifty-second degree of north latitude, there is a regular concomitant fluctuation, that augments as we proceed from the higher latitude towards the equator. According to an hypothesis laid down by our author, there must be a latitude, where the causes that produce the tides will just be *in equilibrio*; and in latitudes still higher the fluctuations will be in an opposite direction. In support of his theory, he adduces the register of the barometer kept in the second northern expedition, and compares it with that kept by Major Long's party during the same season. It may truly be said, that no step in science is unimportant, and that trivial circumstances may frequently produce great good; for we thus see distant observations, taken by scientific men of different nations, and without any previous concert, made use of in the investigation of a subject, that had probably not occurred to the minds of either of the observers, at the time of instituting their experiments. In the new expedition that is about to sail from England, to pursue the discoveries on the northern shore of the American continent, this subject will be made a special matter of research: to furnish the means of comparison, simultaneous observations will be made in London, and arrangements have been made by the British Board of Longitude, to place a similar set of instruments in Columbia College in the city of New-York. In this way, four sets of observations will be made, viz. at London; at Hammerfest, near the North Cape of Europe, where corresponding instruments have been sent; at New-York; and at Prince Regent's Inlet; these observations will be made under two different meridians; that of London being the same with that of Hammerfest, and that of New-York with Prince Regent's Inlet.

In making a series of meteorological observations, the register will be of little importance, unless the instruments be of good quality, and much attention be given by the observer

* Essay 4th.

himself to their accurate adjustment, and to applying the proper corrections*. The instruments commonly sold are mere playthings, and not at all adapted to the present advanced state of physical science. It very rarely happens that two thermometers agree, and when it became necessary, for some important purposes, to procure a standard thermometer, none was found to exist in the hands of any of the artists in London. The case is still worse with the barometer; in those constructed by the same maker, discrepancies of a quarter of an inch may be detected; and even in those to which the names of the first artists are affixed, it rarely happens that the mercury has been purified by boiling. On this subject our author enters at length, and gives full instructions for the choice and construction of instruments. We regret that we cannot, consistently with our limits, enter fully into these interesting details.

From this brief and meagre analysis, some idea may be formed of the talent and ingenuity displayed by Mr. Daniell in his important work. It must, for many years to come, furnish to the observers of atmospheric phænomena the text book by which they are to be guided in their researches. By the application of his rules, and by simultaneous registers, kept in different parts of the world, the science of meteorology, that is now in its infancy, may soon be brought to a comparative degree of perfection. No difficulty need any longer attend the measure of atmospheric pressure and temperature, of the heat of radiation both from the sun and from the earth, of moisture in the air and evaporation from the surface. The quantity of rain and the course of the winds may be readily determined, and the only desiderata that will remain are the phænomena of atmospheric electricity, and the absolute force of the aerial currents.

This paper will be considered as having attained its object, should it render the work to which it relates known to the scientific portion of the American community, and should it awaken some interest in the subject, among persons whose acquirements and leisure would qualify them for observers.

The *Monthly Critical Gazette*, No. I. for June 1st, contains a review of Sir J. E. Smith's *English Flora*. No more impudent and obvious falsehoods ever appeared on paper.

The reviewer says on the subject of *Gramineæ*, that the author has "not once quoted Beauvais:" but the reader may see in vol. i. the list of authors quoted, and then turn to page 83, line 5 from the bottom; p. 85, l. 6; p. 94, l. 8 from the bottom; p. 96, l. 2; p. 109, l. 9 from the bottom; p. 111,

* Essay 8th.

l. 10 ditto; p. 115, l. 19; p. 131, l. 2; p. 135, l. 10; in all which places that excellent writer is cited as he ought to be.

In the *Umbelliferæ*, the reviewer says that Sir J. E. Smith "criticises the labours of Sprengler and Hoffman, and yet never makes a single reference to their works." Whereas in the list of books quoted in vol. ii., both these writers are indicated, at least Sprengel and Hoffmann, which are the true names;—Sprengler was a conchologist. See also, with respect to the latter assertion, p. 42 of this 2d vol. line 24; p. 44, l. 3 from the bottom; p. 45 in two places; 46 to 52; in every page, both authors are once or twice quoted; in pp. 54, 59, 62, 65, 66, 68, 71, 72, 77, 84, 87, 91, 92, 94, 96, 97—103, 105, one or both may be found cited, and Sprengel's *Prodromus*, or his *Species Umbelliferæ*, or both, are always mentioned with respect by our learned President, whether agreeing with them in opinion, or not.

With regard to his quotation of authors in general, his plan seems to be not to burthen the work with the name or page of every author in every country who has mentioned each plant, but to quote such as are useful, and likely to assist an English reader.

What we have said is enough to expose such a barefaced calumny. The rest of the article is no less false and injurious: but it is unnecessary to refute what every person conversant with the subject will see in its true light. The writer abuses Mr. Greville's *Flora* for being arranged after the *Linnæan* method, which is peculiarly obnoxious to those who can get no credit but by attacking it.

Nothing can be more false than what is said of Sir James in this Review about his copying Ray and Tournefort, as he is undoubtedly the first who arranged *Umbellatæ* by all the parts of fructification alone.

We have long seen enough of Reviews to convince us that very little regard is to be paid to their critiques on works of science or research, as the writers employed are either not capable of understanding them, or have some personal interest in misrepresenting them. Thus it happens that the very best works of this description which appear from time to time are either not noticed in the Reviews, or are misrepresented and abused.

ANALYSIS OF PERIODICAL WORKS ON NATURAL HISTORY.

Curtis's Botanical Magazine. No. 452.

Pl. 2509. *Azalea indica*, var. β . *plena*.—*Ornithogalum narbonense*, considered by some authors a variety of *pyrenaicum*, from which however it differs in many particulars.—*Bellis sylvestris*, the distinction between which

and *Arnica Bellidiaztrum* is represented as not quite certain.—*Coreopsis tinctoria*, discovered by Professor Nuttall in the Arkansa territory, North America.—*Monarda Russeliuna*, “caule acutangulo bisulcato, foliis ovatis acuminatis basi rotundatis; inferioribus serratis, labio inferiore revoluta guttato.”—*Euphorbia carinata*, one of the species of the section which Mr. Haworth has made into a genus under the name *Crepidaria*.—*Malva prostrata*, belonging to the fourth of M. Decandolle's sections, of which Mœnch has formed his genus *Modiola*.—*Ophrys Arachnites*, from the collection of C. H. Turner, Esq., who brought it from Switzerland.

The Botanical Register. No. 115.

Pl. 825. *Isochilus prolifer*, a West Indian plant very rare in this country, belonging to the section *Epidendrea* of Mr. Brown's arrangement of Orchideous plants.—*Leucadendron tortum*, described by Mr. Brown in his account of the *Proteaceæ*, *Linn. Trans.* x. 56.—*Ardisia punctata*, “foliis lanceolatis coriaceis sinuatis versus basin attenuatis, corolla subcampanulata punctata: lobis obtusis:” brought from China in 1822 by Mr. John Potts, a meritorious collector, who died in the service of the Horticultural Society.—*Cunonia capensis*. “The natural order *Cunoniaceæ*,” Mr. Brown remarks, “several of whose genera have been referred to *Saxifrageæ*, is more readily distinguished from that family by its widely different habit, than by any very important characters in its fructification.”—*Rosa moschata*, var. *nepalensis*.—*Dolichos purpureus*.—*Arum crinitum*, a most singular plant, native of Minorca. “The remarkable organ,” observes Mr. Lindley, “which in this genus represents the flower, and by botanists is termed *spatha*, is a leaf under a peculiar form of development, assuming the colour, and probably the office, of corolla. It is one of those deviations from the usual order of Nature, which assist the philosophical botanist in understanding the origin of similar organs which have departed more completely from what may be called their primitive forms, and which, with cohesion of parts and alteration of figure, take on new appearances and functions, by which they are so far disguised as to be recognised only in the few plants in which their transition from one form to another has been, as it were, arrested in the middle, and remains incomplete.

“The *spatha* of the *Arum*, which is manifestly a coloured leaf, goes far in support of the ingenious theory of M. du Petit-Thouars*, that all parts of the flower and fruit are modifications of leaves, or leaves in an altered form; or, to employ his own expression,—‘que la Fleur n'est autre chose que la transformation d'une Feuille et du Bourgeon qui en dépend; que la Feuille donne Calice, Corolle, et Etamine, et que le Bourgeon devient le Fruit produisant la Graine;’ and that the bud of a tree and the seed of a tree differ chiefly in this, that the former is an ‘*Embryon fixe*,’ a stationary embryo, and the latter an ‘*Embryon mobile*,’ or moveable embryo. The points upon which this curious speculation depends for support are, that there are no limits between leaves, bractæ, calyx, and corolla; that, in double or monstrous flowers, the stamens and ovaries become foliaceous; that anthers occasionally secrete ovula; that ovaries are known to become polliniferous; that every compound calyx, corolla, or ovary, can be shown to be made up of a determinate and relative number of simple parts; and, finally, that all these organs, in regular flowers, in which no abortion or obliteration has occurred, are produced about their axis, as the leaves about their stem, in a spiral, or, by depression and approximation, verticillate, manner.”

* See above, p. 81.

XL. *Intelligence and Miscellaneous Articles.*

DISRUPTION OF A BOG IN YORKSHIRE.

GREAT interest and some alarm have been excited in Leeds and its neighbourhood by the disruption of a bog on Crow-hill, on the borders of Lancashire, the contents of which have been poured into the river Aire, to the extreme inconvenience and annoyance of the manufacturers upon its banks. On Friday morning, the 3d instant, the river at this place, which was rather swollen, appeared of a colour unusually dark, and which deepened so much in the course of the day that the manufacturers found it impossible to use the water for any purpose of business; and on Saturday morning it was still worse. The water, when taken into a glass, appeared nearly as black as ink; and on being analysed, was found to leave a large residuum of vegetable matter resembling peat. In consequence of this state of the river, it became necessary to suspend entirely many processes in the woollen manufacture, and when it was found that there was no alteration on Monday for the better, much uneasiness was generally expressed as to the probable duration. On Sunday, a letter was received at this office from the Rev. Mr. Bronte, a Minister of the Established Church, residing at Haworth, which gave some explanation of this extraordinary phænomenon: this communication stated, that about six o'clock on Thursday evening, the high lands, on the Moors, about four miles from Haworth, had opened into chasms, from which issued two immense volumes of muddy water, which had inundated the valley through which it flowed to a considerable extent, doing much damage in its course. The Rev. writer concluded with expressing it as his opinion, "that it was the effect of an earthquake, the most considerable too, as to its immediate results, that has taken place in this kingdom for many generations." This communication, which was extensively circulated, rather increased than allayed the public anxiety, as it was generally supposed that some vast subterranean reservoir of water, the accumulation of centuries, had been laid open, which might continue for a period of indefinite extent to pour its turbid waters into the Aire. The Commissioners of the Leeds Water Works, finding that the water could not be applied to any culinary or domestic purposes whatever, gave notice to all the inhabitants by printed handbills, that they should suspend the distribution of water so utterly useless to them. Under these circumstances we thought it right to repair to the spot, and from inquiry and personal observation, endeavour to ascertain the real facts of the case, and we present the following as the result of our investigation:—

Crow-

Crow-hill, the scene of this unusual phenomenon, is about nine miles from Keighley, and six from Colne, at an elevation of about 1000 feet from the former place. The top of the moor, which is nearly level, is covered with peat and other accumulations of decayed vegetables, of a less firm texture: the whole appeared saturated with water, and in most places trembled under the tread of the foot. The superfluous water, at the east end of the moor, drained into small rivulets at the bottom of a deep glen or gill, down a precipitous range of rocks, which presented the appearance of a gigantic staircase; this rivulet passes down the valley to Keighley, and enters the Aire near Stockbridge, about a mile below that town.

At the distance of about 500 yards from the top of the glen, the principal discharge seems to have taken place; here a very large area, of about 1200 yards in circumference, is excavated to the depth of from four to six yards; and at a short distance from this chasm, there is a similar excavation, but much less in extent. These concavities have been emptied not only of their water, but also of their solid contents—a channel, about twelve yards in width and seven or eight in depth, has been formed quite to the mouth of the gill, down which a most amazing quantity of earth and water was precipitated, with a violence and noise of which it is difficult to form an adequate conception, and which was heard to a very considerable distance. Stones of an enormous size and weight were hurried by the torrent more than a mile. It is impossible to form any computation of the quantity of earthy matter which has been carried down into the valley; but that it is enormous is evident from the vast quantities deposited by the torrent in every part of its course, and from the immense quantity which our river still contains. This destructive torrent was confined within narrow bounds by the high banks of the glen through which it passed, until it reached the hamlet of Ponden, where it expanded over several corn fields, covering them to the depth of several feet; it also filled up the mill pond, choking up the water courses, and thereby putting an entire stop to the works. A stone bridge was also nearly swept away at this place, and several other bridges in its course were materially damaged; we feel, however, happy to state, that it was not fatal to life in a single instance. The torrent was seen coming down the glen before it reached the hamlet, by a person who gave the alarm, and thereby saved the lives of some children, who would otherwise have been swept away. The torrent at this time presented a breast seven feet in height. The tract and extent of this inundation of mud may be accurately traced all the way from the summit of the hill to the confluence of the rivulet

rivulet with the Aire, by the black deposit which it has left on its banks. The first bursting of the bog took place about six o'clock in the evening of Thursday, the 2d instant; but another very considerable discharge occurred on the following day, about eight o'clock in the morning; and it is highly probable that other extensive portions of the bog will from time to time be hereafter discharged into the Aire in a similar manner.

The water which drained from the moss on Tuesday, the day on which we visited Crow-hill, was inconsiderable in quantity, and very little discoloured; on Wednesday the appearance of the river at Leeds was much improved, and it was hoped that the heavy rain which fell that day would have had the effect of cleansing its channel; but from the turbid appearance of the water on Thursday morning, we think it highly probable that there has been a further and very considerable discharge from Crow-hill. The Rev. Mr. Bronte, to whose kindness we were indebted for the first information upon the subject, states it as his opinion, that this disruption of the bog was the effect of an earthquake, but none of the appearances countenance this supposition. There has been no irruption of water from the interior of the earth, and the strata of the rocks, as far as they could be observed, did not appear to have been disturbed, nor were any of the springs in the neighbourhood in the least affected. We would further observe that the sinking in of the surface of the earth was the effect, and not the cause, of the disruption of the bog. No human being was upon the spot to witness the commencement of this awful phænomenon, and of course we cannot arrive at any absolute degree of certainty as to its cause: the most probable one is the bursting of a water-spout. The suddenness and violence of the disruption strongly favour this supposition. It would evidently require a power acting with a great degree of momentum to move and break in pieces the immense and almost solid masses of peat and turf which were forced down the hill, to say nothing of the immense stones which were moved. The state of the atmosphere about the time when the disruption took place, also renders this solution highly probable, the air being fully charged with electric matter. "At the time of the irruption," says Mr. Bronte, "the clouds were copper-coloured, gloomy, and lowering; the atmosphere was strongly electrified, and unusually close." These appearances, as they indicated, were followed by a severe thunder storm, during which it is more than probable that some heavy loaded cloud poured its contents upon the spot. We may add, as a further reason in support of this hypothesis, that more water seems to have been sent down the glen than could have been supplied by the contents

tents of the two bogs which have been evacuated. But, perhaps, a still more important inquiry is, What can be done to prevent a recurrence of similar irruptions? This is rather a difficult question; there is, however, no doubt that the drainage of the moss would remove the danger, as no instance exists of either the bursting or floating away of a *drained bog*. Probably the channels now made, should they remain open, will give the requisite stability to the peaty soil. This inundation of bog water has been very fatal to the fish, which have been poisoned or rather suffocated by it in large quantities.

The floating away of a portion of Chat Moss, in the sixteenth century, and of Solway and Pilling Mosses, in the years 1772, and 1744-5, have some remote resemblance to this phenomenon; but the case most analogous to it is that furnished by the mighty discharges from Pendle-hill, in the neighbouring county of Lancaster, of which Camden says, "This hill is chiefly remarkable for the damage which it lately did to the country below (about the year 1580) by the discharge of a great body of water;" and Mr. Charles Towneley, in a communication to Richard Towneley, Esq. in the year 1669, describes a mighty torrent which issued from "the butt-end of Pendle" on the 18th of August, 1669, as so overwhelming that it presented a breast of water of a yard high, and set afloat furniture in the houses of the village of Wooston, at a distance of two miles from the point of disruption.

Since writing the above, we have received a letter from our correspondent at Colne, dated the 9th instant, which confirms our conjecture as to there having been a further considerable discharge from the bog at Crow-hill. He states that "a great quantity of rain fell in that neighbourhood yesterday (Wednesday), and the water again flowed violently from the bog." Our correspondent adds, that it was apprehended that much further injury would be done to the mill dams, &c.

On Thursday, there were not fewer than four irruptions. A gentleman who witnessed the last of them, thus describes it:—About a quarter to 7 o'clock in the evening, he says, the phenomenon began to exhibit itself. On approaching the cavity or canal made by the former irruptions, and which is now about three quarters of a mile in length, himself and his friends perceived a vast body of peaty earth in motion, impelled by the water in the rear, and floated to that which gave the impulse. Soon the substance became stationary, and remained in that state for about ten minutes. By and by, it was again in motion, and moved very gradually down the channel, all the while receiving fresh accessions of mud and peat, till at length the whole cavity was filled with enormous masses,
partly

partly at rest and partly in motion. Having at length reached the brink of the precipice, it rushed over the steep with a tremendous noise, and the discharge was heard distinctly at a distance of four miles. How long the flow continued our friend cannot say, but he heard it for an hour at least after he had quitted the ground, frequently making a noise like the plunge of large bodies precipitated from a considerable elevation into the deep. From the examination which he gave to the summit of the bog, he conceives that a body of peat moss is loosened by these disruptions to the extent of a mile in circumference, and the prevailing opinion on the spot, in which he concurs, is, that this enormous mass will come away before the discharges from Crow-hill finally cease.—The water in the river Aire, at Leeds, yesterday evening was as turbid as it has been at any period since these discharges commenced.—*Leeds Mercury.*

EARTHQUAKES.

A smart shock was felt at New Brunswick on the 9th of July, accompanied by a loud report similar to the discharge of heavy ordnance.

On the morning of Sunday the 8th of August, a smart shock of an earthquake was felt at Comrie, Perthshire, and its neighbourhood. Some houses were perceived to shake, and fire-irons &c. were overturned, but no serious mischief was done. The noise heard has been compared to that caused by a heavy waggon rolled rapidly over a paved causeway.

On the 18th of August, a shock was felt at Harderwyck, in Guelderland. It proceeded in a south-west direction, and the noise accompanying it resembled that of several loaded waggons in rapid motion. In some houses the doors suddenly flew open, and in others the inmates thought the roofs were coming down. Twenty soldiers, who were sleeping on the grass in a plantation near the place, were roused from their slumbers, and much alarmed by the noise and the tremor of the earth.

SIR H. DAVY'S IMPROVED COPPER SHEATHING, AND DR. TIARKS'S TRIGONOMETRICAL SURVEYS.

We laid before our readers in our number for July, Sir Humphry Davy's paper on the means for preventing the corrosion of the copper sheathing of ships. Since that paper was read before the learned Society of which he is president, his discovery has been put to the test of experience.

Sir Humphry has just returned from a voyage to Norway. During the months of July and August he was engaged in pursuing various philosophical researches, for which the Admiralty granted him the use of the *Comet* steam-boat. He has ascer-

tained that his principle of protecting the copper sheathing of ships by the contact of 1-200th of iron, is perfectly successful, even in the most rapid sailing and in the roughest sea; and Dr. Tiarks, by direction of the Board of Longitude, has connected, by chronometrical observations, the trigonometrical surveys of Denmark and Hanover with that of England; so that the triangulation of a great part of Europe may be now said to form one system, M. Arago and Captain Kater having two years ago connected the surveys of England and France by observations between Calais and Dover. In the course of this last expedition to the North Seas, the longitude of the Naze of Norway, a point of great importance in navigation, has been accurately ascertained, and some other useful data for correcting the nautical maps of Europe gained.

CONVERSION OF THE OXALATE AND FORMIATE OF AMMONIA INTO HYDRO-CYANIC ACID: BY M. DÆBEREINER.

Professor Dæbereiner has proved by experiment the existence of a phænomenon whose possibility he had inferred from calculation. This phænomenon is the conversion of the oxalate of ammonia ($\text{NH}^3 + \text{PO}^3$) into cyanogene and water ($\text{CN} + {}^3\text{HO}$). If this salt is mixt with oxalate of manganese, and heated with a spirit lamp in a glass tube closed at one end, we obtain, besides carbonic oxide and carbonate of ammonia, water and cyanogene; but the cyanogene is speedily converted, by the action of the carbonate of ammonia and the water, into hydro-cyanic acid.

The formiate of ammonia ($\text{NH}^3 + \text{CO}^3\text{H}$) decomposed in a glass retort is also converted into hydro-cyanic acid and water ($\text{CNH} + {}^3\text{HO}$).—(*Repert. für die Pharm.* vol. xv. p. 424.)

ON THE TOTAL ABSENCE OF WASPS THIS SEASON.

To the Editors of the Philosophical Magazine and Journal.

Gentlemen,—Among the many curious and at present unexplained circumstances in the natural history of insects, we may consider the total absence of particular tribes in certain seasons, while in others they appear at their wonted time in vast and unusual numbers. Wasps in this district have of late afforded a striking example of this irregularity. For many years past these troublesome insects have been very numerous in the early part of the autumn. They usually appear in August, become very plentiful in September, and disappear by degrees in October. Towards the close of the summer 1821, they were so numerous as to become quite a pest; during September every window was full of them, and several thousands

sands of nests were destroyed in the surrounding neighbourhood. Hornets were likewise more common than usual. In 1822 the wasps again appeared at the usual time, but in no very prodigious quantities. Last year both wasps and hornets were again plentiful. The country abounded with them far and wide, and as usual a great many nests were destroyed. This present season has not produced above one single wasp, at least as far as my observations have extended. Having travelled during the last fortnight on the continent, I noticed the same total absence of wasps and hornets. A single instance occurred of a wasp entering the carriage in which I was travelling in Flanders, which was noticed as a curiosity, no others having been seen. On my return I found that not a single wasp had as yet been seen here. Whether or no the same scarcity of insects usually so troublesome at this time has been observed in remote countries, I am unable to say; but the observations of your correspondents in different parts of Europe would be interesting: for there is an old saying that plenty of wasps indicates plenty of fruit; and this has certainly been a very bad year for most sorts of fruit both in the British Isles and on the Continent, at least in France, Flanders, and the more temperate parts of it. I could relate similar failures in the expected appearance of other sorts of insects in particular seasons, if it were necessary. The cause of their absence is curious. Are they gone elsewhere? Or do wasps sometimes remain dormant over a whole season, or, what is more probable, are they obnoxious to some epidemical distemper? I have noticed the failure of bees in some years, when whole hives of them have been found dead on the ground without any apparent cause.

Hartfield, East Grinstead,
Sept. 20, 1824.

Yours, &c.

T. F.

P.S. It may be remarked that ants, and also the whole tribe of limaceous reptiles, have been very numerous and destructive all this season.

CURE FOR THE CONTAGIOUS GLANDERS.

Mr. Sewel, Assistant Professor of the Veterinary College, Camden Town, well known especially for his happy discovery of curing in many cases, and in all relieving, that hitherto irremediable disease the *founded feet* of horses by excision of nerve, has been equally fortunate in another hitherto incurable disease, the contagious glanders. For this formidable malady he has found a remedy in the use of sulphate of copper given in the form of bolus or ball daily for several weeks. The dose was one to two ounces of sulphate of copper.

The Committee of the Veterinary College, duly sensible of the value of Mr. Sewel's discoveries, have already voted him their thanks, with a handsome augmentation of his salary, and a promise of further rewards.

LOCAL CAUSES OF CARIOUS TEETH AND ODONTALGIA.

It has been lately remarked that caries and pain of the teeth prevail locally, more or less in different districts: about East Grinstead, Tunbridge Wells, Hartfield, and all that part of Sussex, it is particularly common, scarcely any person above 30 having many sound teeth, while in other places this malady is very rare. To what is this to be ascribed?

DOMESTICATED SEAL.

On Friday the 13th of August, Mr. Peter Cooper, salmon fisher, of Gavan (on the Clyde), caught a fine young seal in one of his nets. He took it home with great care, and put it into a large tub full of water. At first it was very backward to feed, and afraid of the people who went to see it. By degrees it acquired more confidence, and is now apparently reconciled to its confinement. It frequently leaves the tub to frolic about in its own awkward way. It is most attached to Mr. Cooper: it follows him constantly while in the house, and is fond of feeding from his hand.—*Edinburgh Observer*.

REMARKABLE GOOSEBERRY PLANT.

Mr. Thomas Ayres, of Duffield, near Derby, communicated to the meeting, on the 27th of August 1821, a description of a remarkably large gooseberry plant growing at Duffield, and of two others in the garden at Overton Hall. That at Duffield is in the garden of Mr. William Bates, a market gardener; it is planted on the east side of a steep hill, the substratum of the soil being a hard grit stone. It is ascertained to have been planted at least forty-six years; the branches extend to twelve yards in circumference, and have produced several pecks of fruit annually for these last thirty years. It is usually manured with soap suds and the drainings from the dung-hill. The two others in the garden at Overton Hall, near Chesterfield, the seat of the late Sir Joseph Banks, are both nearly of the same size. The younger plant is trained to a building, the north and west sides of which it has entirely covered; it was planted thirty years ago. It measures fifty-three feet four inches from one extremity to the other, and yields on an average from four to five pecks of fruit annually. The other, whose age is not ascertained, is planted against a north wall; it extends fifty-four feet, and is now beginning to decay. The soil

soil in which these grow is a brown or hazel coloured light loam. Mr. Ayres was not able to ascertain the name of the variety in the garden at Duffield; those at Overton are said to be the Champagne.—*Trans. of Hort. Soc.* vol. v. p. 490.

METHOD OF GROWING EARLY CELERY.

Mr. John Anderson, Gardener to the Earl of Essex at Cassiobury, communicated in a letter to the Secretary, dated the 5th of November, his method of growing early celery. He forms in the ground a trench six feet wide and one foot deep; into this he puts six inches of rotten dung mixed with a little road grit, and mixes the compost well with the soil by digging it together; the celery is then planted in cross rows six inches apart, and eighteen inches from row to row; as the plants advance they are earthed across the trench. By this means a much larger quantity of celery can be grown in the same space of ground than in the usual way; but the method is only applicable to early celery, for late crops so grown would be liable to rot and perish.—*Trans. of Hort. Soc.* vol. v. p. 492.

MR. VEALL ON THE QUANTITY OF RAIN AND ON THE HEIGHT OF THE BAROMETER IN MAY, IN REPLY TO MR. SQUIRE.

[For Dr. Burney's remarks on the same subjects see p. 208.]

Mr. Squire of Epping having noticed the great disparity in the quantity of rain fallen at Gosport and Boston, as expressed in the Meteorological Table for the month of May, wishes to have some account of the instruments I use, and likewise the locality of their situation.

In compliance with his request I have to inform him, that my rain gauge is of the construction recommended by Dr. Burney of Gosport. It stands in an open situation in a garden: the upper rim of the gauge stands exactly 18 inches from the ground. If any rain, in the course of the 24 hours, I note it down at $\frac{1}{2}$ past 8 every morning. This instrument formerly belonged to the late President of the Royal Society.

The barometer is a common one and hangs constantly in a counting-house. The word "Fair" on the face of it is 6 feet 6 inches from the ground; maker's name, Dollond, London; the time of observation $\frac{1}{2}$ past 8 A.M. Instruments, if made with the greatest care, will however differ more or less.

Certainly the quantity of rain fallen at Boston during the days alluded to was nothing extraordinary; and indeed in no part of this summer have we been here much incommoded with wet.

SAMUEL VEALL.

PRETENDED FOSSIL MAN AND HORSE.

Last year we had our mermaid: it is now the turn of our neighbours.—An attempt has been made to impose on the public credulity at Paris, by the exhibition of the pretended fossil remains of an ante-diluvian man and horse. M. Barruel, one of the dupes by whom it was at first sanctioned, now keeps silence, and neither defends nor disavows his original opinion. M. Huot has discussed the questions arising from the inspection of these stony masses, in a pamphlet, intitled “*Notice géologique sur le prétendu fossile humain, trouvé près de Moret, au lieu dit le Long-Rocher (Seine et Marne).*”

LEARNED SOCIETIES AT CAEN.

A Society of Antiquaries of Normandy has just been established at Caen, where there is also a Linnæan Society for the study of natural history.

LECTURES.

On Monday, October 4th, Dr. Pearson's Medical Lectures, and on Tuesday, October 5th, Mr. Brande's Chemical Lectures, will commence, at 9 o'clock in the morning, at No. 9, George-street, Hanover-square.

Calendar of Flora, Fauna, and Pomona, at Hartfield in Sussex, continued from August 14 to September 14.

Aug. 14.—Swifts (*Hirundines apodes*) still very numerous, whirling round in aerial gyrations and screaming. The small meteors called falling stars very common this evening.

Aug. 19.—The last Swift seen: these birds have been migrating ever since the 14th, and are now all gone. Showery.

Aug. 22.—The Sunflower (*Helianthus annuus*) is in flower in a neighbour's garden: with me this plant has failed, the young plants, together with many China Asters and African Marigolds, having been devoured by the numerous vermin that have swarmed this season in unwonted numbers.

Aug. 28.—Weather hot with variable breezes.

Sept. 3.—We have as yet seen no wasps: it is therefore probable there will be none this year. In 1821 they were particularly numerous, several hundreds of nests having been destroyed in one week; and for the last four or five years they have been very plentiful from the end of August through September.

Sept. 4.—Weather cooler and showery. I travelled to Dover, and noticed swallows and martins to be very numerous.

Sept. 5.—Crossed the Channel to Calais; weather fine: a remarkable

remarkable swell of the sea without wind occurred about noon; it was followed by a gale from the west, of which such a phænomenon was considered to be a certain prognostic as long ago as the time of Aratus.

Sept. 6. — *Cichorium Intybus* and *Papaver Rhæas* by the roadsides going to St. Omers.

Sept. 7.—I noticed the extreme scarcity of plants in flower all the way to Douay. Fine moonlight night.

Sept. 8.—Proceeding from Douay to Valenciennes and Mons, I had occasion to notice the greater luxuriance of vegetation, particularly of trees, when I entered the Flemish territory. The horses and cattle in general, too, are larger than those of France.

Sept. 9.—Travelled to Tournay: weather fine.

Sept. 10.—Weather very fine with light breezes. I saw the *Crepis Meluni* in flower in a ditch between Tournay and Courtray. We passed through Ypres, and slept at Dunkerque. The hops seemed very fine and abundant in Flanders this year*. China Asters, African Marigolds and Michaelmas Daisy in flower in various places.

Sept. 11.—Violent gale from the S.W. The packet however sailed from Calais.

Sept. 12.—High wind, rainy morning and fair evening. The wind fell at night and got more westward, and I distinctly saw the South Foreland light-houses from the pier at Calais.

Sept. 13.—Fine day, but a stiff breeze: slept at Dover.

Sept. 14.—At Hartwell I found *Crocus autumnalis* in flower in abundance. *Nasturtium* still abundant. Stocks and many other flowers still ornament the gardens.

Throughout all France, I learn that this has been as bad a fruit year as in England; the same is the case in Belgium. Cholera and other autumnal complaints prevail much.

T. FORSTER.

LIST OF NEW PATENTS.

To John Vallance, of Brighton, Sussex, esquire, for his improved method or methods of abstracting or carrying off the caloric of fluidity from any congealing water (or it may be other liquids). Also an improved method or methods of producing intense cold. Also a method or methods of applying this invention so as to make it available to purposes with reference to which temperatures about or below the freezing point, may be rendered productive of advantageous effects, whether medical, chemical, or mechanical.—Dated 28th August 1824.—6 months allowed to enrol specification.

To James Neville, of High-street, Southwark, Surry, engineer; and William Busk, of Broad-street, London, esquire, for certain improvements in propelling ships, boats, or other vessels or floating bodies—16th Sept.—6 months.

* Last year we found the hops as scarce and bad at Poperingue and in the neighbourhood of Ypres as they were in Kent.—EDIT.



Electro-Magnetic Apparatus.

Fig. 3.

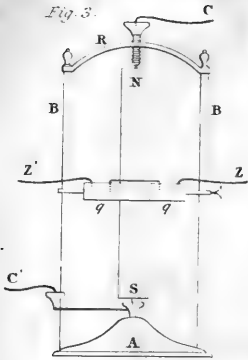

Fig. 4.

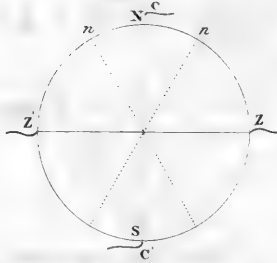

Fig. 2.

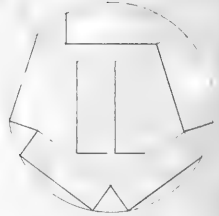

Fig. 1.

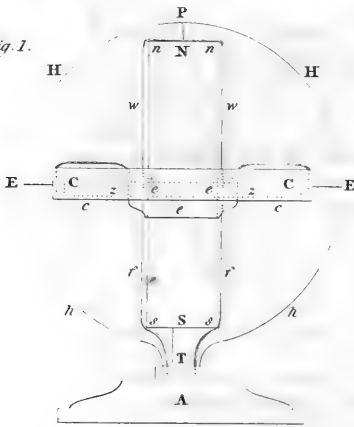
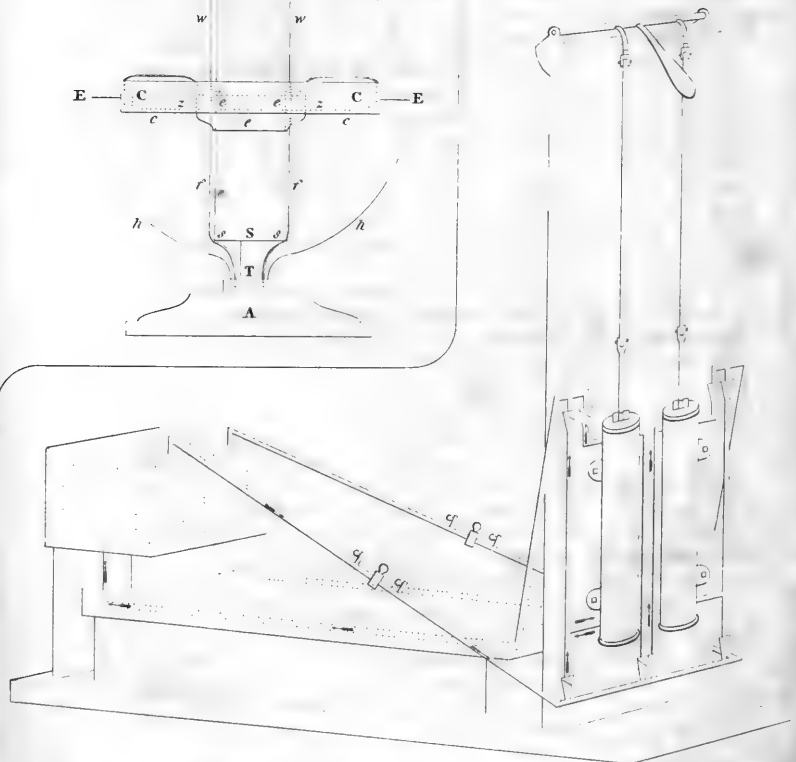

Fig. 5.



THE
PHILOSOPHICAL MAGAZINE
AND JOURNAL.

31st OCTOBER 1824.

XLI. *On the Theories of Vegetation of Sir J. E. SMITH and M. DU PETIT-THOUARS.*

To the Editors of the Philosophical Magazine and Journal.

Gentlemen,

MY friend Mr. John Lindley has, in your Number for August last, given a very clear and comprehensive detail of the theory of vegetation proposed by the ingenious M. Aubert du Petit-Thouars, which I have there perused for the first time, with peculiar pleasure. It is highly satisfactory when the observations and speculations of different physiologists confirm each other, without any communication between the parties; and I cannot but congratulate myself that the theory of the French philosopher in question, whose high character I well know, establishes, in every essential point, that published in my Introduction to Botany, of which the first edition appeared in 1807. The old hypothesis of Du Hamel and others, of the sap being conveyed through the woody fibres, had never satisfied me, and I have been accustomed, in my earlier Courses of Lectures, to show its insuperable defects. Dr. Darwin, and especially Mr. Knight, by their remarks and experiments, confirmed by my own observations, have long ago convinced me, that the spiral-coated vessels of plants convey their sap, or *blood*, into the leaves, there to be acted upon by air, light and heat, so as to form secretions of wood, bark, and *succi proprii*, by the returning vessels. I believe I first suggested, in the above work, that the supposed vernal flowing of the sap is altogether an error, and that there is no running of that fluid along the vessels of a plant, before the leaves open, and then no real circulation; the discharge of sap from a wounded tree in spring being no more than what is caused by the accumulated irritability of the vegetable body during winter. But I beg leave to refer your readers to the work itself, of which a fifth edition, corrected and enlarged, is now printing.

Mr. Lindley must have read my book, and I should have
Vol. 64. No. 318. Oct. 1824. H h expected

expected that he might have recollected so much of it, at least, as to have indicated the points of agreement between my theory and that of M. du Petit-Thouars. But I am very sure my young friend has here been guilty of inadvertence only, and of no disrespect towards me; any more than in his preface to the work of M. Richard on Fruits and Seeds, where Mr. Lindley overlooks all that has been done in England for the advancement of botany, and the correction of Linnæus, for 30 or 40 years past, particularly through the use that has been made of the Linnæan herbarium, and the labours of the Banksian school, whence all Europe has been enlightened and improved in natural science. The artificial system of Linnæus has indeed facilitated the acquisition and the diffusion of botanical knowledge; but the chief good which all natural science owes to this philosopher consists in his principles of definition, description, and nomenclature, as well as in the ideas he first suggested of natural orders and affinities, always protesting, as he did, against forcing such orders into artificial systems.

By the preceding observations I am far from claiming any priority of discovery over M. du Petit-Thouars. Mr. Lindley does not fix the date of his works, nor have I ever seen them. I feel myself sufficiently honoured by the coincidence of our opinions. His ideas of buds are new to me, and elucidate the rest of his theory. I should, however be cautious in admitting all his analogies, however ingenious. Analogy is a treacherous guide in philosophy, and metaphysics are out of place in natural science. It is far easier to speculate ingeniously, than to observe accurately and reason wisely.

I remain, gentlemen,

Your very obedient servant,

Norwich, Sept. 30, 1824.

JAMES EDWARD SMITH.

XLII. On *Electro-Magnetism*. By Mr. W. STURGEON.

To the Editors of the Philosophical Magazine and Journal.

Gentlemen,

IN no experiment hitherto recorded in the whole history of electro-magnetic rotations, do we find employed, at the same time, both poles of the straight bar magnet. Hence all the rotating phænomena yet elicited, by employing that magnet, are only such as obtain by the reciprocal action of one of its poles, and a portion of the conducting wire (under various forms) joining the copper and zinc sides of the battery. And when

when the poles of the magnet or the direction of the force in the wire is changed, the results of the experiments in every case appear to be reversed. And in explanation, these, as well as every electro-magnetic phenomenon, are generally considered to proceed from a reciprocal disposition of the wire and magnet to place themselves at right angles to each other, for, when so situated, and at or near the centre of the latter, nothing further can be obtained; for both wire and magnet, when free to move, will in this position remain at rest.

Convinced as it were that the rotations are in different directions on the opposite poles when employed singly; it would seem as if experimenters had been fully persuaded of the impossibility of obtaining rotations, by bringing into action at the same time both poles of the above-named magnet; or, whatever else may have prevented them, we have never yet heard of any thing of the kind being attempted.

By referring the reader to a Postscript in my last paper on thermo-rotations, and which appeared in your Journal for April last, it will be there seen that a rotation had been obtained under the above circumstances; and that I had at that time rotated the wire or system of wires in the form of a sphere around and by the influence of both poles of an internal magnet.

This experiment, it was observed, first suggested itself on reading Dr. Halley's theory of terrestrial magnetism, and was instituted with a view not only to be somewhat imitative of that philosopher's hypothesis, but likewise to serve in part to exhibit the earth's rotative motion on its axis.

It is by no means intended from this experiment to assert, that the rotatory motion of the earth and planets is really the effect of electro-magnetism, or that the variation of the compass-needle depends upon the theory alluded to; but merely to detail an experimental fact as exhibited by the apparatus in its present imperfect state, the mechanism of which confines the experiment greatly within the limits it might have been extended to. However, it already proves that a galvanized sphere, when free to move and containing within it a magnetic nucleus or kernel, *will rotate* by the influence of that central magnet; and that also, were the magnet free to move, a probability is manifested that it would rotate at the same time, *i. e.* they would both rotate at the same time by the reciprocal action of each other.

Having during my leisure hours been busily employed in fitting up an apparatus for other new experiments, I have not, till now, had an opportunity to describe that by which this is made. The experiment, however, has been witnessed dur-

ring that time by gentlemen eminent in this branch of philosophy, and who have uniformly acknowledged it to be an imposing and pleasing spectacle. It is now offered, with some others which it is presumed are the first of the kind, and which possibly may not be thought uninteresting to some of your readers.

Description of the Apparatus.

Fig. 1 (Pl. II.) *nNn, sSs*, a brass cylindrical tube containing seven bar magnets, each of which is eight inches long. These magnets are placed in a frame in the lower part of the cylinder, the upper end of which being moveable can be taken off at any time to change their position for the purpose of varying the experiment. Fig. 2 is a transverse section of the cylinder with its magnets.

As the like poles of the magnets are all placed in the same end of the tube when used, the latter with its contents may be considered as a compound cylindrical magnet. At the lower end *S* of the cylinder is a stout brass stud *T*, which stands firm in a socket on the top of the foot *A*. Around this socket is a cell for the purpose of holding quicksilver. Another cell *eee* fits gently on the outside of the cylinder, and is suspended over its top part by a stout brass wire *ww*, the extremities of which communicate with the mercury in the cell *eee*; another connecting wire *ff* communicates with the mercury in both cells. *Cc Cc* is a copper vessel made in the form of an Ampère's rotating cylinder, seven inches in diameter; in this vessel is placed a cylinder of zinc, as represented by the dotted lines *zz*. On the outer rim, and at 90° from each other, are soldered four brass studs; to the extremities of which are soldered two brass wire circles (one only of which is shown in the figure) that cross each other at right angles in the pole *P*; from which junction descends a pivot that runs in a hole made to receive it in the upper part of the connecting wire *ww*. The two circles are each 9½ inches diameter, and form two great circles of the sphere they are intended to represent. The lower parts of the circles are left open and the points of the wires bent downwards till they come in contact with the mercury in the lower cell. Two other wires proceed from the upper edge of the zinc cylinder, and terminate in the mercury in the upper cell *eee*, as shown in the figure.

Things being thus arranged, when dilute acid is poured into the copper vessel, the galvanic action takes place throughout every part of the great circles which represent the sphere; ascending from the copper in the upper hemisphere *HH* from the

the equator *EE* to the pole *P*; and descending in the lower hemisphere *hh* from the equator to the mercury in the lower cell, which is the place of the other pole of the sphere. From the poles it is transmitted to the mercury in the upper cell *eee*, by the conducting wires *ww* and *ff*; and both circuits are completed by the wires from the zinc cylinder terminating in this cell. Thus two galvanic circuits are formed by one apparatus; and hence likewise is solved the apparent anomalous phænomena of galvanized wires or cylinders rotating in different directions on the opposite poles of a magnet. This delusive appearance is completely *relative*, and similar to our notions of *up and down*; but with respect to the magnet, and in reality, the rotation is the same on both poles: for example, let any person turn first towards the north, and then towards the south; by observing the heavenly bodies, they would appear to revolve to the left in the former, and to the right in the latter case; yet the rotative motion of the earth (which is the cause of their apparent motion) is constantly the same way. In this experiment both poles of the magnet are acted on at the same time by similar galvanized wires, and the machine rotates by the joint influence of the former on the excited wires of the latter. Owing, however, to the weight and size of the machine, the rotation is but slow at the beginning of the experiment, but soon acquires considerable velocity, and the momentum, added to the generating force, keeps it in motion for a length of time.

Well aware of the difficulties that would arise at the present day in any endeavour to support an hypothesis of the earth's being hollow, and containing within it a spherical magnet, as was the opinion of Dr. Halley, I have confined myself to a detail of the experiment only, without obtruding either remark or opinion. The success of this experiment, however, so satisfactorily confirmed my expectations that the principle upon which it was made could hardly fail to intimate its applicability to others of a like nature; one of which being intimately connected with the one I have just described, this may perhaps be considered no improper place for its detail.

The experiment for rotating the magnet on its axis, it is well known, was first made by M. Ampère; but the manner in which as yet it has been exhibited, like all the other similar experiments, shows the action on one half only of the magnet at one time;—and by reversing the poles (every thing else remaining as before) it appears to rotate in a contrary direction.

I hope, however, that I have satisfactorily proved that this apparent contrariety of rotation is merely relative, and that the real motion is the same in both cases. If possible, however,

ever, the experiment I am about to describe will confirm this property in a more satisfactory manner.

The rotation of the magnet on its axis by subjecting both poles at the same time to the influence of similar electric currents.

Fig. 3 is a representation of the apparatus; and, with the exception of the magnet NS, is entirely of brass-work. A is a round foot, from which rise the two cheeks BB, for the purpose of supporting the annular cell *q* holding quicksilver; and likewise the cross piece R, which is screwed tight down by the knobs *kk*, and thus the apparatus is kept firm and steady. The magnet passes through the opening in the centre of the cell *q*, and communicates with the mercury there contained by means of a wire soldered to its equator, and at right angles to its axis. The poles are furnished with pivots; the lower of which at S runs in a small cup on the top of the foot A; and the upper one at N runs in the lower extremity of a screw nail passing through the cross piece R, and whose head is made into the form of a cup for holding mercury. ZC are two wires proceeding respectively from the zinc and copper side of a battery: the former communicating with the mercury in the cell *q*, and consequently with the equator of the magnet; the latter communicates with the upper pole N in the manner shown in the figure. Thus, one half of the magnet forms part of the galvanic circuit. The other half, from its equator to the lower pole S, forms likewise part of another like galvanic circuit, by means of the wires Z'C' which proceed respectively from the zinc and copper side of another battery, and communicate with the equator and pole in the same manner as the former. By subjecting the magnet in this manner to the influence of like electric currents, it is rotated with an astonishing velocity, but which may in a moment be retarded by interrupting the circuit of either battery; and again accelerated by renewing the contact. This variation of the experiment proves to demonstration the utility of employing both poles at the same time, and is another proof of the rotations on opposite poles, in the old experiments, being merely relative; for the poles of the magnet are here both connected with the copper side, and the equator with the zinc side of the respective batteries. Another advantage in the manner of making this experiment is, that the glass vessel and mercury for floating the magnet are here not used; therefore the whole of the magnet is in view; whereas in the old mode only a small portion of the magnet, about the thickness of a quill, was visible above the surface of the mercury. It can be no small gratification to those who are in the habit of giving public

public lectures, to be enabled to exhibit this experiment to the satisfaction of a large audience; for as the lecturer can now have his rotating magnet of almost any size he pleases, and likewise of any figure, this interesting experiment may be viewed from the remotest part of the lecture-room. Another inconvenience I have almost entirely removed both in making this and every other electro-magnetic experiment. My batteries are of such a peculiar construction as not to annoy the experimenter by the escape of hydrogen; neither is the expense of making the experiments more than one-fortieth of any other method yet made public; yet the apparatus in general is of large dimensions; for instance, the sphere in the former experiment is $9\frac{1}{2}$ inches diameter; and the magnet in the latter is 8 inches long.

I should now proceed to the description of other new experiments, were I not confident that I have already intruded upon your valuable pages. That task must therefore be deferred for the present. Some of the minor of those experiments are,—The rotation of the cylinder by the influence of an external magnet;—Ampère's cylinders rotated independent of each other's weight;—Thermo-rotation on both poles of the magnet;—Electro-magnetic bells, &c.

In summing up the results of the two detailed experiments, it appears from the first,—

That similar electrized wires rotate in the same direction round both poles of the magnet;

That both the copper and zinc cylinders are here carried round the magnet in the same direction;

That a sphere conducting similar currents of electricity from its equator to its poles, will rotate by the influence of an internal magnet.

And from the second it is evident that, had the magnet in the first experiment been free to move, it would likewise have rotated at the same time with the sphere containing it. This property would seem somewhat conformable to the opinion of Halley, who supposed the earth to contain a spherical magnet, which rotated within the shell that we inhabit. And, what is more fortunate to the analogy, it is proved by the experiments that when the electric currents are of the same kind from the equator to the poles of both nucleus and shell, they both rotate in the same direction. The rotation would likewise be as effectual, were the magnetic poles removed to some distance from the axis of motion.

Another hypothesis might be advanced to account for the rotatory motion of the earth, and which would not require the supposition of its being hollow; but only to be regarded as a
grand

grand natural magnet, possessing a capacity for conducting the electric fluid. The former of those properties is admitted by almost every writer on magnetics; and the latter it is presumed will be as readily conceded.

From the second experiment we see the magnet rotate on its axis by the influence of electric currents from its equator to its poles. Had the magnet been a sphere instead of a bar, it might have represented the earth or planet more perfectly; but its figure, it is presumed, can make no difference in the result of the experiment.

It is now well known that electricity can be excited by heat, and the success of thermo rotations in the manner that I obtain them would, if formed into a sphere, depend upon the difference of temperature between the equator and poles. This property is obviously analogous to the natural state of the earth; for the sun exerting his greatest influence a few degrees only on each side of the equator, the polar regions are constantly kept at a very low temperature; so much so, that every attempt yet made to explore them has been rendered abortive in consequence of a prevailing intensity of cold; whilst the equatorial parts, it is well known, are as constantly kept in the other extreme. That thunder and lightning are by far more prevalent in the torrid than in the frigid zones, is a fact that cannot be denied; and that this difference of electrical phænomena is principally caused by the superior action of the sun in those parts, appears more than probable. Hence it may be fairly concluded, that the action of the sun either partly or wholly governs the general electrical phænomena of nature; and, either by producing or exciting this wonderful agency in the equatorial regions, dispenses its influence from thence to the poles of the earth.

Another circumstance that would be something in favour of the hypothesis is, that a magnetic body free to move in any direction, (a sphere suspended in space, for instance,) and having currents of electricity passing over its surface to its poles, would not only rotate, but would likewise maintain its parallelism. This may be easily demonstrated upon the principles shown in Professor Barlow's "Magnetic Attractions," second edition, p. 249, under the head *Electro-magnetism*.

Let $NZC'Z'$, fig. 4, represent the magnetic sphere. NS its poles. Likewise suppose ZC and $Z'C'$ to proceed from the zinc and copper sides of two batteries of equal power. Then the electric force in that part of the magnet between Z and C , or in the northern hemisphere, will tend to carry the pole N towards n . And the electric force in the southern hemisphere between Z' and C' will at the same time have a
like

like tendency to carry the same pole N towards n' . But the pole N being acted on by the two equal and contrary forces, can have no tendency to either of these points, therefore must of necessity remain in its original position.

That pole of the magnet which possesses the same kind of magnetism as the north magnetic pole of our globe, being now properly called *north*; when the zinc sides of the batteries are applied at the equator, the magnet rotates from *east* to *west*: or, in the same direction as the earth.

Having pointed out these particulars, most of which are facts deducible from experiment, there can appear no extreme improbability that most of the phænomena which are observed to obtain with the heavenly bodies in our system, are physically produced by the powerful agency of electricity. And experiments may, in my humble opinion, be instituted, that would satisfactorily exhibit the whole; for we have already seen that rotation and parallelism are producible by electro-magnetism; and the thermo experiments serve to prove that the influence of the sun may be sufficient to excite continual electricity. Hence magnetic bodies placed within its influence may not only rotate and keep their axes parallel, but probably may likewise obey every other observed astronomical law with regular mathematical precision.

I am, gentlemen,

Your most obedient servant,

Artillery-Place, Woolwich, Aug. 1824.

WM. STURGEON.

XLIII. *Introduction to the Seventh Section of BESSEL'S
Astronomical Observations.*

[Continued from p. 178.]

5. *Observations of the Circumpolar Stars.*

IN order to enable us to judge what agreement in the results of observations has been produced by the corrections now investigated, and what remains to be done, I have calculated the polar distances of 59 circumpolar stars for 1820, from all observations made from the time of putting up the instrument to the end of 1821. This calculation has been made with the application of the refraction noted in the journals; but the second column of the following table contains the correction arising from the thermometrical factor; the third the corrections for the errors of the division; the fourth the effect of flexure; and the last the zenith distance resulting from the application of all these corrections. The observations made in each position of the circle are given separately.

	EAST.				WEST.					
	$\frac{\circ}{N}$	Calculated P. D. 1820.	Thermo- meter.	Errors of Division.	Correc- tions for Flexure.	Cor- rected P. D.	Thermo- meter.	Errors of Division.	Correc- tions for Flexure.	Cor- rected P. D.
α Lyrae	10	51 22 41.61	-0.01	-0.33	+0.99	42.26	+0.03	+0.20	+0.91	41.70
β Cygni	7	51 21 21.28	+0.11	0.33	0.99	22.05	+0.12	0.20	0.91	20.62
γ Bootis	12	50 53 58.87	+0.03	0.34	0.98	59.54	+0.02	0.20	0.90	58.96
η Herculis	12	50 43 48.19	+0.06	0.34	0.98	48.89	-0.04	0.20	0.90	46.66
ϵ Persei	11	50 31 12.35	-0.12	0.34	0.97	12.86	-0.10	0.20	0.89	13.05
γ Cygni	9	50 18 52.83	+0.10	0.35	0.97	53.55	+0.13	0.20	0.89	52.95
β Persei	11	49 44 44.44	-0.03	0.35	0.96	45.02	+0.06	0.19	0.88	44.53
η Aurigae	14	49 1 13.47	-0.04	0.37	0.94	14.00	0.00	0.19	0.86	14.15
γ Andromedae	9	48 32 21.10	-0.01	0.37	0.94	21.66	+0.06	0.18	0.85	21.48
ϵ Aurigae	10	46 27 16.15	-0.08	0.38	0.90	16.59	-0.05	0.17	0.81	16.53
α Cygni	23	45 21 30.71	-0.03	0.37	0.88	31.19	-0.04	0.17	0.79	31.72
α Aurigae	24	44 11 50.05	-0.06	0.37	0.86	50.48	-0.03	0.16	0.77	51.13
1ω Cygni	10	41 12 34.71	+0.09	0.34	0.80	35.26	+0.11	0.19	0.71	35.17
α Persei	11	40 47 18.64	-0.03	0.33	0.79	19.07	-0.03	0.20	0.70	19.25
θ Cygni	7	40 11 28.71	+0.08	0.32	0.78	29.25	+0.11	0.21	0.69	29.43
c ——— seq.	3	39 53 45.47	+0.07	0.32	0.78	46.00	+0.10	0.22	0.68	46.09
c ——— præc.	7	39 53 18.81	+0.08	0.32	0.78	19.35	+0.11	0.21	0.68	18.98
η Ursae Maj.	11	39 47 6.07	+0.01	0.32	0.78	6.54	+0.03	0.21	0.68	6.39
1ω Cygni	5	39 37 44.16	+0.05	0.31	0.77	44.67	+0.03	0.22	0.68	43.44
3 Lacertae	10	38 40 11.75	+0.04	0.29	0.75	12.25	+0.06	0.25	0.66	12.76
γ Cygni	7	38 38 58.70	+0.08	0.29	0.75	59.24	+0.11	0.25	0.66	60.08
γ Draconis	14	38 29 10.08	-0.01	0.29	+0.75	10.53	+0.04	+0.25	+0.66	9.79

β Draconis	37	33	40.32	-0.03	-0.27	+0.73	40.75	8	41.26	-0.01	+0.28	+0.64	42.17
20 Cygni	37	27	54.40	+0.08	0.27	0.73	54.94	12	54.02	+0.11	0.28	0.64	55.05
XXI. 32	6	37	10 6.21	0.05	0.26	0.73	6.73	10	6.10	+0.03	0.28	0.63	7.04
α Cygni	6	36	57 35.27	0.08	0.26	0.72	35.81	13	34.98	+0.10	0.29	0.63	36.00
51 Draconis	6	36	52 34.31	0.08	0.26	0.72	34.85	12	32.68	+0.11	0.30	0.63	33.72
XX. 391	10	36	10 12.99	0.08	0.24	0.70	13.53	10	11.75	+0.09	0.32	0.61	12.77
γ Ursæ Maj.	11	35	18 15.94	0.00	0.22	0.69	16.41	19	16.22	+0.01	0.33	0.59	17.15
c Draconis	6	34	38 22.46	0.07	0.21	0.68	23.00	11	21.64	+0.10	0.35	0.58	22.67
XXI. 336	6	34	37 60.84	0.08	0.21	0.68	61.39	7	58.63	+0.07	0.35	0.58	59.63
49 Draconis	6	34	35 46.50	0.08	0.20	0.68	47.06	12	46.01	+0.10	0.35	0.58	47.04
α Cassiopeiæ	12	34	27 4.45	0.02	0.20	0.67	4.90	15	4.07	0.00	0.35	0.58	5.00
μ Cephei	3	34	14 19.05	0.03	0.20	0.67	19.55	7	17.94	+0.07	0.36	0.58	18.95
33 Cygni	8	33	58 47.93	0.08	0.19	0.66	48.48	6	46.11	+0.11	0.36	0.57	47.65
ε Cephei	10	33	51 5.00	0.05	0.19	0.66	5.52	10	3.71	+0.05	0.36	0.57	4.69
53 Draconis	6	33	26 40.55	0.07	0.18	0.65	41.09	12	38.95	+0.10	0.37	0.56	39.98
ζ Cephei	12	32	41 0.81	0.02	0.16	0.64	1.31	14	0.01	+0.03	0.39	0.54	0.97
δ Cephei	8	32	30 13.51	0.06	0.15	0.63	14.05	12	13.22	+0.04	0.39	0.54	14.19
48 Draconis	6	32	25 17.13	0.07	0.15	0.63	17.68	12	15.62	+0.09	0.39	0.54	16.64
2 Cephei Hev.	9	31	37 55.64	0.06	0.13	0.62	56.19	10	54.74	+0.09	0.41	0.52	55.76
θ Draconis	11	30	57 4.63	0.03	0.12	0.61	5.15	9	4.59	-0.01	0.42	0.51	5.51
ο —	6	30	49 45.09	0.07	0.12	0.60	45.64	12	44.45	+0.09	0.42	0.51	45.47
XX. 292	10	30	11 5.38	0.06	0.11	0.59	5.92	9	3.69	+0.08	0.43	0.49	4.69
10 Cephei	5	29	42 26.91	0.04	0.11	0.58	27.42	12	25.98	+0.04	0.44	0.49	26.95
η —	11	28	51 28.30	0.05	0.08	0.56	28.83	11	28.76	+0.05	0.45	0.47	29.73
66 Draconis	5	28	31 30.01	0.06	0.07	0.56	30.56	9	29.19	+0.08	0.46	0.46	30.19
α Cephei	9	28	10 28.60	0.05	0.06	0.55	29.14	15	27.78	+0.02	0.47	0.46	28.73
γ Draconis	9	28	4 34.60	+0.02	-0.06	+0.55	35.11	11	33.91	-0.07	+0.47	+0.46	34.77

		EAST.						WEST.					
		Calculated P. D. 1820.	Thermo- meter.	Errors of Division.	Correc- tions for Flexure.	Cor- rected P. D.	δ N.	Calcu- lated P. D.	Thermo- meter.	Errors of Division.	Correc- tions for Flexure.	Cor- rected P. D.	
α	Ursæ Maj.	27 16 46.24	-0.03	-0.06	+0.53	46.68	9	46.21	-0.04	+0.47	+0.44	47.08	
β	Cephei	20 13 40.94	+0.03	-0.09	+0.39	41.27	13	40.71	+0.02	+0.47	+0.31	41.51	
λ	Draconis	19 40 36.87	0.00	-0.09	+0.38	37.16	11	36.36	-0.03	+0.46	+0.30	37.09	
κ	—	19 13 6.65	-0.01	-0.10	+0.37	6.91	14	5.13	-0.03	+0.44	+0.30	5.84	
γ	Ursæ Min.	17 31 31.63	+0.02	-0.11	+0.34	31.88	12	30.91	0.00	+0.39	+0.27	31.57	
β	—	15 6 31.45	+0.05	-0.14	+0.29	31.65	11	30.86	+0.05	+0.30	+0.23	31.44	
γ	Cephei	13 22 17.87	-0.02	-0.17	+0.26	17.94	18	17.94	0.00	+0.23	+0.20	18.37	
ζ	Ursæ Min.	11 39 25.01	+0.01	-0.19	+0.22	25.05	11	23.97	+0.02	+0.16	+0.17	24.32	
δ	—	3 25 18.43	—	-0.15	+0.06	18.34	—	18.23	—	-0.01	+0.05	18.27	
α	—	1 39 5.84	—	-0.07	+0.02	5.79	—	5.61	—	0.00	+0.02	5.63	
α	—	— 1 39 5.84	—	+0.03	-0.03	5.84	—	5.61	—	0.00	-0.02	5.63	
δ	—	— 3 25 18.43	—	+0.07	-0.06	18.42	—	18.23	—	0.00	-0.03	18.26	
ζ	—	— 11 39 25.58	0.00	+0.10	-0.20	25.68	9	24.94	0.00	0.00	-0.13	25.07	
γ	Cephei	13 13 22 19.16	0.00	+0.10	-0.24	19.30	22	19.04	-0.01	+0.01	-0.15	19.19	
β	Ursæ Min.	7 15 6 31.48	-0.12	+0.11	-0.26	31.75	5	32.05	-0.12	+0.03	-0.17	32.31	
γ	Ursæ Min.	10 17 31 32.23	0.00	+0.11	-0.30	32.42	9	31.90	0.00	+0.07	-0.19	32.01	
κ	Draconis	10 19 13 6.07	-0.02	+0.11	-0.32	6.30	11	6.19	-0.03	+0.10	-0.20	6.32	
λ	—	19 40 37.19	-0.02	+0.11	-0.33	37.43	6	37.15	-0.01	+0.11	-0.20	37.25	
β	Cephei	20 13 40.88	+0.22	+0.11	-0.34	40.89	11	41.72	+0.05	+0.13	-0.21	41.95	
α	Ursæ Maj.	27 16 46.47	+0.04	+0.08	-0.44	46.79	10	46.73	0.00	+0.34	-0.25	46.64	
γ	Draconis	28 4 33.84	0.00	+0.07	-0.44	34.21	6	34.71	+0.18	+0.34	-0.26	34.45	
α	Cephei	28 10 28.20	+0.29	+0.07	-0.45	28.29	13	28.43	+0.10	+0.35	-0.26	28.24	

66 Draconis	11	—	28	31	28.90	+	0.29	+0.05	—	0.45	29.01	8	28.62	+0.29	+0.34	—	0.26	28.25
γ Cephei	9	28	51	29.21	0.35	+	0.04	+	0.46	29.28	11	29.03	0.20	0.34	0.26	28.75		
10	11	29	42	25.89	0.31	+	0.01	+	0.47	20.04	8	25.46	0.18	0.32	0.26	25.22		
XX. 222	8	30	11	4.52	0.27	—	0.01	—	0.47	4.73	8	4.08	0.31	0.32	0.27	3.72		
δ Draconis	10	30	49	46.89	0.45	—	0.03	—	0.48	46.95	10	45.66	0.27	0.31	0.27	45.35		
θ	11	30	57	4.74	0.09	—	0.03	—	0.48	5.16	7	4.62	0.16	0.31	0.27	4.42		
2 Cephei Hev.	9	31	37	56.16	0.37	—	0.06	—	0.49	56.34	9	55.42	0.34	0.29	0.27	55.06		
48 Draconis	10	32	25	17.35	0.52	—	0.09	—	0.50	17.42	10	16.79	0.32	0.28	0.27	16.46		
δ Cephei	13	32	30	13.67	0.24	—	0.09	—	0.50	14.02	6	13.84	0.26	0.28	0.27	13.57		
ζ	13	32	41	0.64	0.30	—	0.10	—	0.50	1.14	10	0.55	0.01	0.28	0.27	0.53		
53 Draconis	10	33	26	40.39	0.60	—	0.14	—	0.51	40.44	10	40.52	0.36	0.27	0.28	40.17		
ε Cephei	14	33	51	4.87	0.29	—	0.16	—	0.52	5.26	6	4.94	0.29	0.26	0.28	4.67		
33 Cygni	10	33	58	46.59	0.40	—	0.16	—	0.52	46.87	8	47.26	0.39	0.26	0.28	46.89		
μ Cephei	9	34	14	17.96	0.25	—	0.17	—	0.52	18.40	3	16.65	0.31	0.26	0.28	16.36		
α Cassiopejæ	10	34	27	5.86	0.12	—	0.19	—	0.52	6.45	19	5.16	0.11	0.26	0.28	5.07		
49 Draconis	10	34	35	46.91	0.63	—	0.19	—	0.52	46.99	10	47.60	0.37	0.25	0.28	47.26		
XXI. 336	5	34	37	58.18	0.51	—	0.19	—	0.52	58.38	5	60.35	0.20	0.25	0.28	60.18		
γ Ursæ Maj.	11	35	18	16.37	0.17	—	0.23	—	0.53	16.96	15	16.18	0.22	0.24	0.28	16.00		
XX. 391	7	36	10	14.18	0.61	—	0.26	—	0.54	14.37	10	14.46	0.45	0.23	0.28	14.06		
51 Draconis	10	36	52	34.20	0.75	—	0.29	—	0.55	34.29	10	34.78	0.44	0.22	0.28	34.40		
κ Cygni	10	36	57	34.50	0.77	—	0.29	—	0.55	34.57	10	36.22	0.46	0.22	0.28	35.82		
XXI. 32	8	37	10	4.76	0.60	—	0.29	—	0.55	5.00	7	6.55	0.47	0.22	0.28	6.14		
20 Cygni	9	37	27	54.94	0.55	—	0.30	—	0.55	55.24	9	55.42	0.51	0.20	0.28	54.99		
β Draconis	15	37	33	40.81	0.29	—	0.31	—	0.55	41.38	6	41.37	0.17	0.21	0.28	41.27		
γ	15	38	29	9.26	0.28	—	0.33	—	0.56	9.87	7	9.46	0.22	0.21	0.28	9.31		
ι Cygni	11	38	38	60.00	0.78	—	0.33	—	0.57	60.12	8	58.42	0.46	0.21	0.28	58.03		
3 Lacertæ	13	—	38	40	12.28	+	0.36	—	0.57	12.82	5	12.87	+0.42	+0.20	0.28	12.53		

If the errors of division had not been taken into account, it is evident from this comparison that the upper passages would have given the polar distances sensibly greater in the eastern position of the circle, than in the western position: with regard to the lower passage the contrary would take place; the difference is indeed not very great, but I am confident that this excellent instrument can determine still smaller quantities; and I consider the correction obtained by the investigation of the errors of division, though it never exceeds $0''\cdot6$, as an essential addition to the accuracy of the declinations, the establishing of which is the object of this investigation. After allowing for the errors of division and of flexure, the agreement is as satisfactory as the accidental errors of observations and the errors of the curve that undoubtedly still remain would allow us to expect.

The errors of division applied for the place of the pole are taken from the table in Art. I. in the eastern position at $+0''\cdot21$, in the western at $+0''\cdot32$: but it cannot be supposed that the curve should give them quite correctly; and if they are not correct, a constant difference of the polar distances observed in both positions of the instrument will be produced, which may be determined to advantage by the comparison of several stars, the observations of which depend on different parts of the circle. Calling the true errors of division $+0''\cdot21 + x$ and $+0''\cdot32 + x'$, we have for the upper passages

$$x + x' = \text{East Polar Distance} - \text{West Polar Distance}.$$

And for the lower passages

$$x + x' = \text{West Polar Distance} - \text{East Polar Distance}.$$

By a mean of 100 comparisons I found

$$x + x' = -0''\cdot028.$$

The comparison of the upper passages with the lower ones will give (in the next article) $x - x'$, by which x and x' may be determined in such a manner that if the places of the pole obtained by the two pole-stars be thereby corrected, these may be considered as having been derived from a mean of *all* stars that have been observed.

6. *Refraction.*

The polar distances observed in both passages, and corrected for the change of the thermometrical factor, the errors of division and flexure, as given in the preceding article, still involve the error of the mean refraction. This I shall so determine as to obtain the greatest possible agreement for both passages. Let the refractions employed in the calculation for the upper passage of a star be called g , for the lower one g' , that

that for the pole r : again, let the corresponding true refractions be denoted by $g(1+k)$, $g'(1+k)$; and let the polar distances calculated from the mean of all observations of the upper passage be $=P$; the same from the mean of the observations of the lower passage be $=P'$, the true polar distance is

$$= P - \frac{1}{2}(x-x') + (r \mp g)k = P' + \frac{1}{2}(x-x') + (g' - r)k$$

and hence the equations of condition for the refraction

$$0 = P' - P + (x-x') + (g' \pm g - 2r)k.$$

In order to give a proper value to these equations, and in general more accurately to determine the capability of the instrument, I must begin with the investigation of the probable errors with which the results of the circle, when corrected by the table of the errors of division, are still affected. This investigation may be grounded on the differences of the polar distance in both positions of the circle; if the probable contingent error of observation be expressed by ε , the probable error of division, after applying the correction in the table by e , the probable difference of the results of a eastern, and a' western observations is $= \sqrt{\left\{ 2e^2 + \frac{\varepsilon^2}{a} + \frac{\varepsilon^2}{a'} \right\}}$, and we have, if the really existing difference be called v ,

$$(0.6745)^2 \Sigma [v \pm 0''.028]^2 = 2ne^2 + \Sigma \left(\frac{\varepsilon^2}{a} + \frac{\varepsilon^2}{a'} \right)$$

where n signifies the number of polar distances that have been compared. Assuming ε as determined in the 3d article, all the stars from the pole to α Cygni inclusive give

$$e = \pm 0''.2794.$$

This e is the limit of the probable accuracy of a polar distance observed in *one* position of the circle only, which by ever so great a repetition of observations never can be further diminished; for a determination made in *both* positions of the circle the same limit is $= \frac{e}{\sqrt{2}} = \pm 0''.1976$.

If a result be required which is to have a much smaller probable error, it can only be found by employing for its determination observations depending on distant points of the limb of the circle: the nature of the instrument requires, therefore, to have recourse to that means, wherever it is possible to do so, for determining refraction, latitude, &c.

The equations of condition for refraction have the probable errors

$$\sqrt{\left\{ e^2 + \frac{1}{2}e^2 \left(\frac{a'-a}{a'+a} \right)^2 + \frac{1}{2}e^2 \left(\frac{b'-b}{b'+b} \right)^2 + \frac{\varepsilon^2}{a'+a} + \frac{\varepsilon'^2}{b'+b} \right\}}$$

where ε' , b , b' signify the same for the lower passage which ε , a , a' express for the upper one. From this formula the numerical values of the errors which are contained in the following table have been computed.

	P	P'	P' - P	$\xi' + \xi - 2r.$	Probable Errors.
α Ursæ Min.	1 39' 5"71	5"73	+0"02	6"2	0"279
δ —	3 25 18"30	18"33	+0"03	0"5	0"279
β —	11 39 24"58	25"33	+0"75	5"9	0"374
γ Cephei	13 22 18"13	19"23	+0"10	7"0	0"330
β Ursæ Min.	15 6 31"53	31"98	+0"45	8"2	0"390
γ —	17 31 31"71	32"23	+0"52	13"0	0"362
α Draconis	19 13 6"20	6"31	+0"11	15"1	0"365
λ —	19 40 37"12	37"37	+0"25	16"4	0"373
β Cephei	20 13 41"40	41"50	+0"10	20"1	0"374
α Ursæ Maj.	27 16 46"86	46"72	-0"14	36"0	0"362
η Draconis	28 4 34"92	34"30	-0"62	40"0	0"379
α Cephei	28 10 28"88	28"26	-0"62	43"9	0"359
66 Draconis	28 31 30"38	28"69	-1"69	47"5	0"376
η Cephei	28 51 29"28	28"99	-0"29	48"2	0"365
10 —	29 42 27"09	25"69	-1"40	51"4	0"383
XX. 222	30 11 5"34	4"23	-1"11	54"7	0"381
θ Draconis	30 49 45"53	46"15	+0"62	60"3	0"378
θ —	30 57 5"31	4"89	-0"42	54"8	0"376
2 Cep. Hev.	31 37 55"96	55"70	-0"26	63"9	0"377
48 Draconis	32 25 16"99	16"94	-0"05	69"4	0"382
δ Cephei	32 30 14"13	13"88	-0"25	65"9	0"382
3 —	32 41 1"13	0"87	-0"26	65"4	0"362
53 Draconis	33 26 40"35	40"31	-0"04	75"9	0"383
ϵ Cephei	33 51 5"11	5"08	-0"03	74"9	0"381
33 Cygni	33 58 47"91	46"88	-1"03	78"3	0"396
μ Cephei	34 14 19"13	17"89	-1"24	77"8	0"453
α Cassiopeie	34 27 4"96	5"55	+0"59	75"5	0"365
49 Draconis	34 35 47"05	47"13	+0"08	74"1	0"383
XXI. 336	34 37 60"44	59"28	-1"16	81"8	0"437
γ Ursæ Maj.	35 18 16"88	16"41	-0"47	79"6	0"358
XX. 391	36 10 13"15	14"19	+1"04	96"4	0"382
51 Draconis	36 52 34"10	34"35	+0"25	104"2	0"389
α Cygni	36 57 35"94	35"20	-0"74	106"4	0"389
XXI. 32	37 10 6"92	5"53	-1"39	105"3	0"408
20 Cygni	37 27 55"01	55"12	+0"11	109"7	0"394
β Draconis	37 33 41"35	41"35	0"00	104"5	0"392
γ —	38 29 10"21	9"70	-0"51	114"3	0"374
ι Cygni	38 38 59"79	59"24	-0"55	123"4	0"394
3 Lacertæ	38 40 42"51	12"74	+0"23	118"8	0"400
1 α Cygni	39 37 3"88	42"64	-1"24	132"4	0"414
η Ursæ Maj.	39 47 56"47	5"27	-1"20	125"6	0"385
c Cyg. præc.	39 53 19"14	18"25	-0"89	142"3	0"455
— seq.	39 53 46"06	46"27	+0"21	140"0	0"484
θ Cygni	40 11 29"37	29"33	-0"04	145"1	0"395
α Persei	40 47 19"15	19"27	+0"12	142"1	0"385
1 ω Cygni	41 12 35"22	33"83	-1"39	159"1	0"406
α Aurigæ	44 11 50"76	49"45	-1"31	216"8	0"361
α Cygni	45 21 31"45	29"81	-1"64	254"8	0"370
ι Aurigæ	46 27 16"57	15"18	-1"39	280"2	0"444
γ Andromedæ	48 32 21"56	20"32	-1"24	393"5	0"483
η Aurigæ	49 1 14"10	12"30	-1"80	419"6	0"500
β Persei	49 44 44"83	42"67	-2"16	481"2	0"515
γ Cygni	50 18 33"25	52"37	-0"88	579"6	0"629
c Persei	50 31 12"95	9"14	-3"81	560"4	0"654
η Herculis	50 43 48"00	45"78	-2"22	649"7	0"745
γ Bootis	50 53 59"31	56"20	-3"11	682"5	1"003
σ Cygni	51 21 21"25	18"85	-2"40	724"5	1"131
α Lyre	51 22 41"89	41"24	-0"65	723"7	1"006

It is evident that the observations may be much improved by adopting a somewhat greater refraction; for the more accurate determination of its increase I have made use of all stars the zenith distance of which does not exceed 85° (as far as β *Persei* inclusive); and by solving the equations of condition I have obtained

$$\begin{aligned} x-x' &= -0''\cdot031, & \text{probable error} &= \pm 0\cdot076 \\ k &= +0''\cdot004624 \quad . \quad . \quad . \quad . \quad . & &= \pm 0\cdot0006063 \end{aligned}$$

The stars culminating lower as far as *Lyræ* agree very well with this; but I abstained from taking them into account because the horizontal refraction has already a sensible influence on them, and for determining the horizontal refraction observations at the time of rising and setting of stars may be more advantageously employed than meridian observations. A very complete set of this kind of observations has been made by Dr. Argelander, with Cary's circle, which are contained in this volume; but I reserve for another place the results to be deduced from them.

The value of $x-x'$ combined with that of $x+x'$ gives $x = -0''\cdot033$; $x' = +0''\cdot005$; they are therefore almost insensible, and it follows that the places of the pole derived from the two pole stars only very nearly agree with those determined from all observations. The difference is so small that it is nearly indifferent which of the two determinations be adopted, but the probability of the second one is greater than that of the former, both from the nature of the instrument and the evidence of the calculated probable errors, which are for x and x' only $=0''\cdot076$. I have therefore applied these small corrections, as well as those arising from the increase of the refraction, to the polar distances of the stars given in the 5th article; these polar distances have thus been freed from all those errors, the correction of which was announced in the beginning as the object of this investigation. In order to perceive, at one view, how great the agreement has now become, I present in the following table a comparison of the four determinations of the polar distance made for each star, with the most probable one resulting from all observations in both passages, on the supposition of the probable error of each of the four results being $=\sqrt{\left(e^2 + \frac{e^2}{a}\right)}$.

	Polar Distance 1820.	Probable Error.	Deviation of the single Results.				
			Upper Passage.		Lower Passage.		
			East.	West.	East.	West.	
α Ursæ Min.	0 1 39 5-73	0-14	+0-10	-0-09	+0-09	-0-09	
δ —	3 25 18-35	0-14	+0-04	-0-05	+0-06	-0-07	
ζ —	11 39 25-06	0-19	+0-09	6 -0-67	11 +0-68	9 +0-10	12
γ Cephei	13 22 18-77	0-16	-0-72	23 -0-31	18 +0-61	13 +0-53	22
β Ursæ Min.	15 6 31-84	0-19	-0-07	9 -0-31	11 0-00	7 +0-59	5
γ —	17 31 32-11	0-18	-0-10	10 -0-37	12 +0-44	10 +0-07	9
α Draconis	19 13 6-46	0-18	+0-59	7 -0-50	14 -0-01	10 +0-04	11
λ —	19 40 37-36	0-18	-0-05	8 -0-15	11 +0-23	13 +0-07	6
β Cephei	20 13 41-58	0-18	-0-16	11 +0-05	13 -0-51	8 +0-57	11
α Ursæ Maj.	27 16 47-04	0-18	-0-17	11 +0-20	9 +0-04	12 -0-08	10
η Draconis	28 4 34-90	0-19	+0-40	9 +0-03	11 -0-38	10 -0-10	6
α Cephei	28 10 28-86	0-18	+0-47	9 +0-03	15 -0-25	10 -0-27	13
66 Draconis	28 31 29-81	0-19	+0-93	9 +0-54	9 -0-46	11 -1-19	8
η Cephei	28 51 29-41	0-18	-0-39	11 +0-48	11 +0-21	9 -0-29	
10 ³ —	29 42 26-72	0-19	+0-89	5 +0-39	12 -0-32	11 -1-11	
XX. 222	30 11 5-10	0-19	-1-01	10 -0-25	9 +0-01	8 -0-97	
σ Draconis	30 49 46-13	0-19	-0-30	6 -0-50	12 +1-22	10 -0-35	
θ —	30 57 5-38	0-19	-0-03	11 +0-30	9 +0-17	11 -0-54	
2 Cephei Hev.	31 37 56-19	0-19	+0-20	9 -0-26	10 +0-51	9 -0-67	
48 Draconis	32 25 17-33	0-19	+0-55	6 -0-52	12 +0-55	10 -0-39	
δ Cephei	32 30 14-30	0-19	-0-05	8 +0-07	12 +0-16	13 -0-26	
ζ —	32 41 1-32	0-18	+0-19	12 -0-17	14 +0-26	13 -0-32	
53 Draconis	33 26 40-72	0-19	+0-58	6 -0-56	12 +0-21	10 -0-03	
ϵ Cephei	33 51 5-40	0-19	+0-33	10 -0-53	10 +0-35	14 -0-21	
33 Cygni	33 58 47-69	0-20	+1-00	8 -0-36	6 -0-31	10 -0-27	
μ Cephei	34 14 18-84	0-22	+0-92	3 +0-29	7 +0-07	9 -1-95	
α Cassiopeia	34 27 5-64	0-18	-0-52	12 -0-45	15 +1-31	10 -0-04	
49 Draconis	34 35 47-44	0-19	-0-17	6 -0-22	12 +0-08	10 +0-38	
XXI. 336	34 38 0-35	0-21	+1-25	6 -0-53	7 -1-45	5 +0-38	
σ Draconis	34 38 23-01	0-27	+0-20	6 -0-16	11 0-		
γ Ursæ Maj.	35 18 17-00	0-18	-0-37	11 +0-34	19 +0-48	11 -0-45	
XX. 391	36 10 13-98	0-19	-0-23	10 -1-02	10 +0-99	7 +0-71	
51 Draconis	36 52 34-68	0-19	+0-39	6 -0-77	12 +0-25	10 +0-39	
α Cygni	36 57 36-00	0-19	+0-03	6 +0-19	13 -0-78	10 +0-50	
XXI. 32	37 10 6-51	0-20	+0-45	6 -0-73	10 -0-86	8 +0-31	
20 Cygni	37 27 55-47	0-19	-0-31	7 -0-22	12 +0-43	9 +0-21	
β Draconis	37 33 41-79	0-19	-0-81	11 +0-58	8 +0-24	15 +0-16	
γ —	38 29 10-37	0-18	+0-39	14 -0-37	14 +0-20	15 -0-33	
ϵ Cygni	38 38 59-92	0-19	-0-45	7 +0-34	13 +0-93	11 -1-13	
3 Lacertæ	38 40 13-01	0-20	-0-53	10 -0-05	10 +0-53	13 +0-26	
1 α Cygni	39 37 43-85	0-21	+1-06	5 -0-20	9 -0-48	9 -0-34	
η Ursæ Maj.	39 47 6-39	0-19	+0-39	11 +0-21	10 -1-17	9 +0-26	
c Cygni præc.	39 53 19-26	0-22	+0-33	7 -0-07	9 +0-42	6 -1-06	
— scq.	39 53 46-63	0-24	-0-39	3 -0-33	6 +0-35	6 +0-65	
θ Cygni	40 11 29-80	0-19	-0-31	7 -0-16	13 +0-69	12 -0-18	8
α Persei	40 47 19-71	0-19	-0-39	11 -0-24	9 +0-18	10 +0-62	12
1 ω Cygni	41 12 35-06	0-20	+0-44	10 +0-32	9 +0-08	9 -0-73	8
α Aurigæ	44 11 50-88	0-18	-0-14	24 +0-49	18 -0-53	14 +0-01	20
α Cygni	45 21 31-53	0-18	-0-07	23 +0-43	22 -0-04	14 -0-58	16
ϵ Aurigæ	46 27 16-78	0-21	+0-09	10 0-00	5 -0-44	10 +0-28	10
γ Andromed.	48 32 21-98	0-21	-0-04	9 -0-25	12 +0-33	9 +0-45	9
η Aurigæ	49 1 14-38	0-22	-0-69	14 +0-03	6 +0-41	10 -0-24	9
β Persei	49 44 45-08	0-22	+0-23	14 -0-29	9 -0-22	9 +0-28	11
γ Cygni	50 18 53-82	0-24	+0-01	9 -0-61	9 +0-95	9 +2-23	6
ϵ Persei	50 31 13-04	0-23	+0-12	11 +0-28	9 -0-53	9 -1-87	6
η Herculis	50 43 48-25	0-24	+0-93	12 -0-32	8 +0-06	7 +1-74	5
γ Bootis	50 53 59-55	0-25	+0-28	12 -0-33	8 -0-88	2 +0-43	5
σ Cygni	51 21 21-62	0-26	+0-72	7 -0-74	9 -0-20	6 +2-77	5
α Lyrae	51 22 42-65	0-23	-0-09	10 -0-68	20 +0-82	8 +0-98	7

This comparison seems to confirm that the manner of reducing the observations which has been employed, is correct as far as the accidental errors of observation will allow to perceive it; the remaining differences of the four independent determinations of each star are either not greater than would be expected, or nowhere so regular as to prove the neglecting of any constantly acting error: I believe, therefore, that it may be assumed that the polar distances of the stars observed with Reichenbach's meridian circle, and computed agreeably to this investigation, vary, like the right ascensions, in both positions of the instrument and in both passages only on account of contingent errors, from each other: the separate investigation of each individual correction seems to justify the hope that not only agreement, but likewise correctness, has been obtained within narrow limits.

It now only remains to reduce the refraction and its changes to the true Fahrenheit's thermometer. The refraction is found for $48^{\circ}.75$ of Schafrinsky's thermometer $= g.1.004624$, where g signifies the number taken from the table in the *Fundamenta Astronomiæ*: it follows from the 3d article and the supposed influence of the temperature on the mercury of the barometer, that the difference of two refractions for the readings τ and τ' , of the exterior and the centesimal degrees τ' and τ'_1 , of the interior thermometer is =

$$g \left\{ \frac{1+10m}{1+\tau'm} \times \frac{1-\frac{1}{2}n}{1+(\tau-50)n} - \frac{1+10m}{1+\tau'_1m} \times \frac{1-\frac{1}{2}n}{1+(\tau'-50)n} \right\}$$

where m is by supposition $= 0.00018484$, and n has been found $= 0.00194653$. Let $g(1+y)$ signify the true refraction for $48^{\circ}.75$ Fahr., and $1:1+g$ the ratio of the densities of the air at the points of boiling and freezing, as they must be assumed for representing as exactly as possible the changes of refraction: I suppose besides, agreeably to the accurate experiments of Messrs. Dulong and Petit, the ratio of the densities of mercury $= 55.5:56.5$, and for the brass of the scale of the barometer $537:538$. Then the true refraction will be =

$$g(1+y) \left(\frac{b}{333.28} \right) \frac{5550+10}{5550+\tau'} \times \frac{35700+\tau'}{53700+10} \times \frac{180+g.16.75}{180+g.(f-32)}$$

If we put $f = 0.997039\tau - 0^{\circ}.538$ as found in article 2, we have for $\tau = 48^{\circ}.75$, $f = 48^{\circ}.06765$; therefore the refraction observed at that temperature

$$g.1.004624 = g(1+y) \frac{5550+10}{5550+\tau'} \times \frac{53700+\tau'}{53700+10} \times \frac{180+g.16.75}{180+g.16.06765}$$

This equation may be abridged by putting $\tau' = \frac{2}{9}(f - 30^{\circ}.067)$,
which

which is not much different from the truth, and has little influence: we then have

$$1.004624 = (1 + y) \frac{180 + \epsilon \cdot 16.75}{180 + \epsilon \cdot 16.06765} \quad (1)$$

and hence the true change of refraction =

$$\left\{ g(1 + y) \frac{0.9998266}{1 + m'(f - 50)} \times \frac{180 + \epsilon \cdot 16.75}{180 + \epsilon (f - 32)} - \frac{0.9998266}{1 + m'(f' - 50)} \cdot \frac{180 + \epsilon \cdot 16.75}{180 + \epsilon (f_i - 32)} \right\}$$

where $m' = 0.000089557$.

If $1 + y$ be denominated from this equation by the equation (1), the change of refraction will be

$$= g.10044492 \left\{ \frac{1}{1 + m'(f - 50)} \cdot \frac{180 + \epsilon \cdot 16.06765}{180 + \epsilon (f - 32)} - \&c. \right\}$$

The same is by observation substituting f' for τ

$$= g.0.9960353 \left\{ \frac{1}{1 + (f - 50)0.00010248} \times \frac{1}{1 + (f - 50)0.0019497} - \&c. \right\}$$

These two equations give

$$1 + y = 1.003282 \quad - \quad - \quad - \quad \text{probable error} = \pm 0.00061$$

$$g = 0.36438 - (f + f_i - 100)0.000000501 \dots \pm 0.0016.$$

The latter is therefore almost independent of the temperature of the observations; indeed g may without hesitation be assumed = 0.36438, as the mean temperature of all observations will be nearly = 50°. If we suppose that the mean humidity of the air is nearly the mean between dryness and saturation, it will be seen from article 3 that this determination is in near accordance with that found by Gay-Lussac.

In order to satisfy as nearly as possible the observations at Königsburg, the refraction derived from Bradley's observations must be multiplied by 1.003282; but this change, small as it is, would perhaps not be necessary if we had a more accurate knowledge of the meteorological instruments used by Bradley; his thermometer was in melting snow at 33° to 33½°, and accordingly I assumed that it was 1°.25 too high; but I am indebted to Prof. Tralles for the communication, that melting snow when already mixed with water always gives the freezing point too high, so that the correction applied to the thermometer becomes doubtful; but without this correction the new refractions would hardly differ from the former ones.

[To be continued.]

XLIV. *On the Specific Heat of the Gases.* By W. T. HAYCRAFT, Esq.

[Concluded from p. 207.]

Experiments on Hydrogen.

HYDROGEN gas was procured from the decomposition of water by means of sulphuric acid and zinc. The part B Plate II., was filled with the same, and the following experiments were made.

No. 1.

In this experiment the calorimeters were filled with water of the same temperature, and the process was conducted on rather a different principle than the former; namely, it was continued until the calorimeters ceased to rise in temperature, or, rather, till the temperature began to fall. This latter circumstance would take place when the heat communicated by the gas was exactly equal to that abstracted by the colder surrounding medium. The number of degrees of temperature, then, which each gas would sustain in its calorimeter, will be the ratio of its power for giving out heat, and consequently of its capacity for caloric.

The temperature of calorimeter A, at the beginning of the experiment, was about 50° , and after 105 minutes the temperature of calorimeter A was $82^{\circ}\frac{1}{2}\frac{5}{10}$, and that of B, containing hydrogen gas, was $82^{\circ}\frac{1}{2}\frac{0}{10}$, and the surrounding medium $60^{\circ}\frac{9}{10}$, indicating the comparative capacity of hydrogen to be 98.64, being a difference so trifling, that it may be regarded as the same as that of atmospheric air; if we make allowance for the evident greater ratio in its heating, and the smaller ratio of its rate of cooling at the end of the experiment. This will be seen by the following table.

	Temperature of A, containing Atmo- spheric Air.	Temperature of B, containing Hy- drogen Gas.
At the beginning } of experiment, }	50°	50°
In 5 minutes,	59	58.6
In 10 minutes,	$67\frac{1}{2}\frac{6}{10}$	$66\frac{1}{2}\frac{1}{10}$
In 15 minutes,	$71\frac{1}{2}\frac{6}{10}$	$71\frac{1}{2}\frac{4}{10}$
In 20 minutes,	75	$73\frac{4}{10}$
In 25 minutes,	$77\frac{1}{2}\frac{6}{10}$	76
In 30 minutes,	79	$77\frac{6}{10}$
In 35 minutes,	$80\frac{1}{2}\frac{2}{10}$	$78\frac{1}{2}\frac{0}{10}$
In 40 minutes,	$81\frac{1}{2}\frac{2}{10}$	$80\frac{3}{10}$
In 45 minutes,	$82\frac{8}{10}$	81
In 50 minutes,	83	$82\frac{9}{10}$
In 55 minutes,	$83\frac{1}{10}$	$82\frac{8}{10}$
In 60 minutes,	$83\frac{2}{10}$	$82\frac{1}{2}\frac{2}{10}$
In 65 minutes,	$83\frac{3}{10}$	$82\frac{1}{2}\frac{6}{10}$
In 70 minutes,	$82\frac{1}{2}\frac{6}{10}$	$82\frac{1}{2}\frac{0}{10}$

No. 2.

	Temperature of A, containing Atmo- spheric Air.	Temperature of B, containing Hy- drogen Gas.	Inferred Capacity.
At the beginning of experiment, }	$49\frac{3}{20}$	$49\frac{7}{20}$	
After 5 minutes,	$55\frac{6}{20}$	$55\frac{10}{20}$	10500
After 10 minutes,	60	$60\frac{8}{20}$	10424
After 15 minutes,	$64\frac{10}{20}$	$64\frac{8}{20}$	9950
After 20 minutes,	$67\frac{2}{20}$	$67\frac{2}{20}$	10002
After 25 minutes,	$69\frac{4}{20}$	$69\frac{3}{20}$	10000

This last experiment was conducted as the former ones.

The air appeared, after the experiments, to contain 88 per cent. of hydrogen gas, as indicated by explosion with oxygen gas*.

In these two experiments it may be observed, that the watery vapour which may be presumed to be in the hydrogen gas, before it had been sufficiently exposed to the drying influence of the muriate of lime, seemed to decrease in specific heat, exactly contrary to what might be expected. In the first experiment, at the expiration of the first five minutes, it had a capacity of 9222, pretty nearly the same as indicated in the experiments of Messrs. De la Roche and Berard; but in proportion as the experiment had advanced, and the hydrogen had been exposed longer to the muriate of lime, its specific heat approached to that of atmospheric air, till, at the end of the experiment, they were quite equal.

No. 2. was performed upon the same hydrogen, in its driest state; and throughout the whole experiment it indicated also a capacity equal to the standard. In this experiment I know of no source of fallacy, as the gases, while entering into the calorimeters, were of exactly the same temperature, and care was taken to ensure accuracy.

Azote.

Of azote I shall merely state, that last year I performed

* The apparatus which I found most convenient for exploding gases, is a modification of Dr. Ure's syphon eudiometer. It consists of a hole bored in the solid bottom of a mercurial trough, representing an inverted syphon; one end of which opens into the part containing mercury, and the other through the edge of the trough to the open air. To the latter opening is cemented an open glass tube; and to the former a common graduated eudiometer is made to fit accurately. When this apparatus is used, the graduated tube is filled in the usual way, and applied to the opening communicating with the trough. Mercury is poured into the other tube, to the same height as that contained in the graduated one. The finger is then applied to the open tube, and the electric spark passed. After the explosion, more mercury is poured into the open tube, to the same height that it had risen in the eudiometer, after which the degrees are read off.

similar

similar experiments upon this gas, the results of which were perfectly analogous with those now detailed; and as all the experiments agree that it has by volume the same specific heat as atmospheric air, namely 1000, I thought it needless to repeat them.

Carburetted Hydrogen.

In my former experiments on carburetted hydrogen, procured from the decomposition of sea-coal, I concluded that it also had the same capacity as atmospheric air; but I have since found that the capacity of this gas varies extremely, according to the modes in which it is procured. That produced from sea-coal seems to have a capacity nearly equal to the standard; that from the decomposition by heat of animal fat, has a much greater capacity. From the following experiments, however, it will appear that olefiant gas owes its increased capacity to the empyreumatic or ethereal vapour with which it is usually combined.

No. 1.

This experiment I conducted in the same way as No. 1. on hydrogen gas. The part B was filled with olefiant gas obtained from the gas-pipes of a public Company. The calorimeters at the beginning of the experiment contained water of the temperature of 50° . At the end of 50 minutes the calorimeter A had acquired its utmost temperature of $92^{\circ}\frac{7}{20}$, and of B that of $93^{\circ}\frac{1}{20}$; the surrounding medium being $66^{\circ}\frac{8}{20}$.

No. 2.

The calorimeters were of a temperature of $52^{\circ}\frac{5}{20}$ at the beginning of the experiment: after 55 minutes, the calorimeter A had acquired a temperature of $92^{\circ}\frac{1}{20}$, and B that of $94^{\circ}\frac{4}{20}$; the surrounding medium being 65° . The average result of these experiments, Nos. 1. and 2., indicates the specific heat of olefiant gas to be 10559. Though the results of these two experiments do not quite agree with those I formerly made, yet the difference is very trifling, and may be supposed to arise from the greater freedom of the gas I formerly made use of, from empyreumatic vapour. This will appear probable from the following experiments.

No. 3.

The part of the apparatus B was filled with carburetted hydrogen, procured by the destructive distillation of mutton-suet. The calorimeters were filled with water of the temperature of $50^{\circ}\frac{1}{20}$. At the end of 40 minutes, the calorimeter through which the olefiant gas passed had acquired its extreme temperature of 95° , the other that of $88^{\circ}\frac{1}{20}$; the surrounding medium being $65^{\circ}\frac{2}{20}$; indicating the specific heat of olefiant gas to be 12777.

That

That the gas procured from animal fat contains more empyreumatic vapour, is evident from its sensible qualities, which may account for its greater specific heat, compared with that procured from sea-coal. The gases, at the end of the experiment, were exactly of the same temperature as when entering into the calorimeters.

No. 4.

The last experiment was repeated, except that the olefiant gas was procured from alcohol and sulphuric acid. After 25 minutes, the calorimeter A had assumed the temperature of $74^{\circ}\frac{4}{20}$, and calorimeter B that of $75^{\circ}10$; the surrounding medium being 54° ; indicating the capacity of olefiant gas to be 10643.

No. 5.

The last experiment was repeated, and gave a result of 10674; the medium result of experiments Nos. 4 and 5, being 10658, indicating the capacity of olefiant gas procured from alcohol and from sea-coal to be almost exactly the same.

No. 6.

Wishing to ascertain if the ethereal or empyreumatic vapour in olefiant gas affected its specific heat, I poured a few drops of sulphuric ether into the part of the apparatus containing atmospheric air, that the latter, as well as the olefiant gas, being equally saturated with the vapours of ether, it might be ascertained what effect that condition might have on the capacities of the gases. The part B contained the olefiant gas as before. After 40 minutes, both the calorimeters had acquired a temperature of $85^{\circ}\frac{5}{20}$, the surrounding medium being $61^{\circ}\frac{4}{20}$. The inference, then, may fairly be made, that it is the combined vapour that increases the specific heat of olefiant gas.

Experiments on the Air of Respiration.

Having last year made more than ten experiments which prove that the mixtures of carbonic acid with atmospheric air exposed freely to water, and at a temperature of about 100° , had a much less capacity for heat than atmospheric air had, under ordinary circumstances, and this curious fact seeming to throw some light upon the physiology of animal respiration, I filled the part B with air from the lungs, and the part A with atmospherical air.

The heating apparatus was kept, by means of a lamp, at the temperature of between $97^{\circ}\frac{10}{20}$ and $100^{\circ}\frac{10}{20}$. After the end of 35 minutes, the calorimeter through which the air of respiration passed attained the temperature of $59^{\circ}\frac{4}{20}$, and the other that

of $61^{\circ}\frac{4}{20}$; the surrounding medium being $54^{\circ}\cdot 16$, indicating the air of respiration to be 6875.

No. 2.

The last experiment was repeated, when the calorimeter arose from $56^{\circ}\frac{2}{20}$ to $58^{\circ}\frac{10}{20}$, and B from $56^{\circ}\frac{3}{20}$ to $57^{\circ}\frac{16}{20}$, indicating the capacity of the air of respiration to be, as in the last experiment, 6875.

It may not be improper in this place to state, that in my former experiments mixtures of carbonic acid and atmospheric air, under different conditions of temperature, and combination with watery vapour, had relative capacities of 3333, 66666·9999, and 13333. It was my intention to have repeated those experiments in such a way as to ascertain the precise conditions under which these changes of capacities took place; but, from various engagements, I am unable to do so. I may remark, however, that the last two experiments seem to indicate, that the air of respiration enters into the second of this series, making allowance for the difference of the standard of comparison; this being in my former experiments common undried atmospherical air, while the standard of the latter was the same air carefully dried.

There is also a curious coincidence between this last-mentioned series of capacities of gas in different states of combination with water, and the expansive forces of air combined also with different proportions of watery vapours. Having procured a glass globe, to which a small stem was connected, in such a way that mercury contained in the hollow ball would rise into the stem upon any increase of the expansive force of the air contained in the ball, I filled the latter with air at a temperature of 60° ; after which the ball was immersed into boiling water. In a short time the mercury rose into the stem to the height of 7 inches. The experiment was repeated, excepting that a few drops of water were put, together with the air, into the ball. The mercury, after the immersion of the ball in boiling water, rose to 21 inches. Afterwards, on passing a quantity of water into the ball, the mercury, after its immersion, rose to 28 inches. Some months afterwards, on repeating the experiment, the mercury rose in one instance to 14 inches. Thus we have a series of expansive forces of air united to watery vapour of 7, 14, 21 and 28 inches: it was upon this principle that I contrived an air thermometer. The form of it is similar to that of the differential thermometer invented by Professor Leslie. One ball contained atmospherical air dried by means of muriate of lime; the other contained air in its usual state. Interposed between the balls was a column

lumn of the volatile spirit of turpentine. Upon any rise of the temperature of the atmosphere, the column immediately rose at the side of the dry ball. After some time, however, the instrument seemed to have lost its power; and after a still longer period, the ball containing dry air had the greater expansive force. This I accounted for by supposing, that the vapour of turpentine had in process of time combined with the dry air, and had given it its greater expansive power. This thermometer is now a remarkably delicate one, though its degrees are of very unequal length, and appear to vary by lapse of time. Probably hydrogen gas contained in two platina balls, in one of which a little mercury might be placed, connected together in the same way, would make an accurate pyrometer, indicating temperatures as high as the melting point of platina.

There is another condition under which air is capable of a great variety of specific heats, namely, when it exists in different degrees of density, whether arising from pressure or other causes. The increased capacity of air, when under lesser degrees of atmospheric pressure, has been properly made use of to explain the extreme cold which exists in high regions; and its decreased capacity under mechanical pressure, also satisfactorily accounts for the heat evolved under that condition. This principle, so far as I know, has not been used to explain one cause of the intense heat produced during the combustion of gunpowder and other explosive mixtures. If we reflect a moment, however, we shall perceive that the resistance of the pressure of the atmosphere to the expansion of the nascent gases produced by the combustion, will cause them to exist in a state of greater density than when the resistance of the atmosphere has been finally overcome. It is during this state of potential compression, if I may use the term, that the intense heat is produced. After the first explosion, however, the gaseous products will expand, and then there will necessarily be an absorption of caloric, and consequently comparative coldness, produced. In order to ascertain whether there is a permanent evolution of caloric, occasioned by the combustion of gunpowder, I made the following experiment.

Having a receiver containing 528 cubic inches, filled with water of a temperature of 52° , placed in a pneumatic trough; the surrounding atmosphere being also 52° , I introduced 240 inches of the aëriform fluids, produced during the combustion of that composition of gunpowder which is used for pyrotechnical purposes. After the explosion, the gas in the upper part

of the receiver had acquired a temperature of nearly 54° , and the water not so much. This experiment shows, that though heat is evolved in the combustion of gunpowder, its quantity is not nearly so great as has been imagined. Again, if we consider that the products of the combustion of gunpowder have not, by direct experiment, been proved to have a greater specific heat than the ingredients of that composition, the phenomenon of heat being produced during that combustion should not be urged as an objection to the hypothesis of Black and Crawford. Indeed it appears very probable, from the inspection of the table of specific heats of different bodies, that those elastic products have a less capacity than the ingredients of gunpowder, from which they are produced. For example, azote, which composes two-thirds of the elastic products, has a capacity of 2669, and carbonic acid, comprising one-third of the products, if my experiments are to be trusted to, has a capacity of only 1751, water being 10000. Nitric acid of a specific gravity of 1,1354 has a capacity of 5760. The azote, therefore, and oxygen, which is produced from the decomposition of one of the ingredients forming the elastic products of not half the specific heat of that ingredient, should, according to the hypothesis of Black, evolve heat. This might take place even if we make allowance for the lesser capacity which nitric acid has in its state of one of the ingredients of the nitrate of potash.

The same condition of potential compression may also contribute to the intense heat which takes place in a blast-furnace. This heat is known by all conversant with the phenomenon to be, not in a ratio of the fuel consumed, but of some compound ratio. This may be explained in the following manner: 1st, A quantity of air is forced into contact with the coals in a state of ignition, and its temperature is suddenly raised extremely high. 2d, In this condition, were it not for the pressure of the atmosphere, it would become as suddenly expanded. 3d, Had this expansion taken place, it would have acquired an increased capacity, and would consequently have absorbed a considerable portion of the caloric evolved by the combustion, tending thereby to lessen the capacity of the heat. 4th, But the heated air being prevented by the pressure of the atmosphere from expanding in a ratio equal to the temperature acquired, the absorption of caloric is lessened, and a greater proportion of the heat of combustion is rendered free. Thus, although the total quantity of caloric evolved at, and consequently to combustion, may be in a direct ratio of the quantity of fuel consumed; yet the intensity of the thermometrical heat at the moment,

ment, and at the place of combustion, will be greater in a compound ratio, directly as the pressure of the atmosphere, and inversely as the times of expansion of the air employed in the blast. These times are, of course, inversely as the intensity of the blast. The thermometrical heat, then, at the moment and place of combustion, will be in a compound ratio of the quantity of fuel consumed, the weight of the atmosphere, and the quantity of air employed in the blast in a given time. The same rule will hold even in what are called Chimney Furnaces; and it is ascertained by experience, that those furnaces of steam-engines through which a greater quantity of air passes in a given time, consume a proportionally less quantity of fuel to produce the same effect. Probably blast-furnaces might be advantageously employed in lessening the quantity of fuel used for those valuable machines.

Although, according to the foregoing experiment, it appears contrary to my original expectation, that, by volume, oxygen gas has the same specific heat as carbonic acid, it by no means follows that caloric should not be evolved during the formation of the latter by combustion. This formation does not consist of a conversion of oxygen into carbonic acid, but of a union of two ingredients into a compound, having an absolute capacity for caloric equal to one of the ingredients only, namely, the oxygen gas; consequently the whole absolute heat of the carbon is rendered free.

The direct results of these experiments show, that the specific heats of all the gases experimented upon are to each other inversely as their specific gravities; and, 2dly, That different states of combinations of the gases with aqueous and other vapours, affect the capacities of the gases, and that probably, in some instances, in a regular arithmetical progression, corresponding with the arithmetical rate of expansive force of the gases in different states of combination with vapour. The most interesting result to the physiologist is, that the air of respiration, at a temperature of between $100\frac{1}{2}^{\circ}$ and 95° , has a less specific heat than atmospherical air. Many experiments were made which are not here detailed, which showed that the air of respiration, at the temperature of 102° and upwards, and of 91° and downwards, had a capacity the same as that of atmospherical air. I should feel a hesitation in stating these results, had not experiments, very often repeated, during a course of several months, warranted me in my conclusions.

XLV. *An improved Demonstration of Sir ISAAC NEWTON'S Binomial Theorem, on Fluxional Principles, more especially calculated for the young Student in Mathematics. By the Rev. L. EVANS, F.R.S. and A.S. &c.*

LET $(P + PQ)^n$ represent any binomial to be involved or extracted, n being any power, or root, of the given quantity $P + PQ$.

Now, $(P + PQ)^n = P^n \times (1 + Q)^n$.

And here we may preliminarily observe, that

$$\begin{aligned} (1 + Q)^2 &= 1 + 2Q + Q^2, \\ (1 + Q)^3 &= 1 + 3Q + 3Q^2 + Q^3, \\ (1 + Q)^4 &= 1 + 4Q + 6Q^2 + 4Q^3 + Q^4 \text{ \&c.} \end{aligned}$$

Hence, generally, we are induced to assume the n th power of $(1 + Q)$ by a series, as thus,

$(1 + Q)^n = 1 + AQ + BQ^2 + CQ^3 + DQ^4 + EQ^5 + \&c.$ the coefficients A, B, C, D, E &c. in the respective terms of the series, after the first, to be determined hereafter. Let, now, both sides of this equation be put into fluxions, and we have

$$n \cdot (1 + Q)^{n-1} \dot{Q} = A\dot{Q} + 2BQ\dot{Q} + 3CQ^2\dot{Q} + 4DQ^3\dot{Q} + 5EQ^4\dot{Q} + \&c.$$

Dividing both sides by \dot{Q} ,

$$n \cdot (1 + Q)^{n-1} = A + 2BQ + 3CQ^2 + 4DQ^3 + 5EQ^4 + \&c.$$

This equation being divided by the assumed one,

$$\frac{n \cdot (1 + Q)^{n-1}}{(1 + Q)^n} = \frac{A + 2BQ + 3CQ^2 + 4DQ^3 + 5EQ^4 + \&c.}{1 + AQ + BQ^2 + CQ^3 + DQ^4 + EQ^5 + \&c.}$$

$$\text{Or, } \frac{n}{1 + Q} = \frac{A + 2BQ + 3CQ^2 + 4DQ^3 + 5EQ^4 + \&c.}{1 + AQ + BQ^2 + CQ^3 + DQ^4 + EQ^5 + \&c.}$$

Multiply by the alternate denominators,

$$\begin{aligned} n + nAQ + nBQ^2 + nCQ^3 + nDQ^4 + nEQ^5 + \&c. = \\ \left. \begin{matrix} A + 2B \\ + A \end{matrix} \right\} Q + \left. \begin{matrix} 3C \\ + 2B \end{matrix} \right\} Q^2 + \left. \begin{matrix} 4D \\ + 3C \end{matrix} \right\} Q^3 + \left. \begin{matrix} 5E \\ + 4D \end{matrix} \right\} Q^4 + \&c. \end{aligned}$$

and by transposition,

$$\left. \begin{matrix} +nA \\ n - A - 2B \\ - A \end{matrix} \right\} Q - \left. \begin{matrix} -nB \\ - 3C \\ - 2B \end{matrix} \right\} Q^2 - \left. \begin{matrix} +nC \\ - 4D \\ - 3C \end{matrix} \right\} Q^3 - \left. \begin{matrix} +nD \\ - 5E \\ - 4D \end{matrix} \right\} Q^4 - \left. \begin{matrix} + \\ - \\ - \end{matrix} \right\} \&c. = 0.$$

By the lemma in Section XIV. of Simpson's Algebra, we have

1. $n - A = 0$;
2. $nA - 2B - A = 0$;
3. $nB - 3C - 2B = 0$;
4. $nC - 4D - 3C = 0$;
5. $nD - 5E - 4D = 0$; &c.

Now,

Now, from these equations are derived the values of the respective coefficients A, B, C, D, E, &c. thus,

1. From $n - A = 0$,
 $n = A$.
2. From $nA - 2B - A = 0$;
 $nA - A = 2B$,
 $(n-1)A = 2B$,
 $\frac{n-1}{2} \cdot A = B$, by substitution,
 $n \cdot \frac{n-1}{2} = B$.
3. From $nB - 3C - 2B = 0$,
 $(n-2) \cdot B = 3C$,
 $\frac{n-2}{3} \cdot B = C$, by substitution,
 $n \cdot \frac{n-1}{2} \cdot \frac{n-2}{3} = C$.
4. From $nC - 4D - 3C = 0$,
 $(n-3) \cdot C = 4D$,
 $\frac{n-3}{4} \cdot C = D$, by substitution,
 $n \cdot \frac{n-1}{2} \cdot \frac{n-2}{3} \cdot \frac{n-3}{4} = D$.
5. From $nD - 5E - 4D = 0$,
 $(n-4) \cdot D = 5E$,
 $\frac{n-4}{5} D = E$, by substitution,
 $n \cdot \frac{n-1}{2} \cdot \frac{n-2}{3} \cdot \frac{n-3}{4} \cdot \frac{n-4}{5} = E \text{ \&c.}$

Having, thus, found the values of the several coefficients, A, B, C, D, E, &c. the assumed equation, by the substitution of these respective values, will become

$$(1 + Q)^n = 1 + nQ + n \cdot \frac{n-1}{2} Q^2 + n \cdot \frac{n-1}{2} \cdot \frac{n-2}{3} Q^3 +$$

$$n \cdot \frac{n-1}{2} \cdot \frac{n-2}{3} \cdot \frac{n-4}{4} Q^4 + \text{\&c.}$$

Then $P^n \times (1 + Q)^n$, or

$$(P + PQ)^n = P^n + PnQ + Pn \cdot \frac{n-1}{2} Q^2 + Pn \cdot \frac{n-1}{2} \cdot \frac{n-2}{3} Q^3 +$$

$$Pn \cdot \frac{n-1}{2} \cdot \frac{n-3}{4} \cdot \frac{n-4}{5} Q^4 + \text{\&c.}$$

Or, by writing the coefficients of Q more conveniently,

$$(P + PQ)^n = P^n + P^n nQ + P^n nQ \frac{n-1}{2} \cdot Q + P^n n \cdot \frac{n-1}{2} \cdot Q^2 \cdot \frac{n-2}{3} Q +$$

$$P^n n \cdot \frac{n-1}{2} \cdot \frac{n-2}{3} Q^3 \cdot \frac{n-3}{4} Q + \text{\&c.}$$

In this series we may observe that its first term, P^n , is the coefficient of nQ in the second term; the second term, $P^n nQ$, is the coefficient of $\frac{n-1}{2}Q$ in the third term; the third term, $P^n n \cdot \frac{n-1}{2} \cdot Q^2$, is the coefficient of $\frac{n-2}{3} \cdot Q$ in the fourth; the fourth term, $P^n n \cdot \frac{n-1}{2} \cdot \frac{n-2}{3} Q^3$, is the coefficient of $\frac{n-3}{4} Q$ in the fifth term, and so on, in like manner, *ad infinitum*. Now, putting

$$A = P^n, \text{ the 1st term,}$$

$$B = P^n nQ, \text{ the 2nd term,}$$

$$C = P^n n \cdot \frac{n-1}{2} Q^2, \text{ the 3rd term,}$$

$$D = P^n n \cdot \frac{n-1}{2} \cdot \frac{n-2}{3} Q^3, \text{ the 4th term,}$$

$$E = P^n n \cdot \frac{n-1}{2} \cdot \frac{n-2}{3} \cdot \frac{n-3}{4} Q^4, \text{ the 5th term, \&c.}$$

Then, by substitution, we have

$$(P + PQ)^n = P^n + nAQ + \frac{n-1}{2}BQ + \frac{n-2}{3}CQ + \frac{n-3}{4}DQ + \frac{n-4}{5}EQ + \&c.$$

And, if we make $n = \frac{m}{n}$, whether affirmative or negative, integral or fractional, we shall have

$$(P + PQ)^{\frac{m}{n}} = P^{\frac{m}{n}} + \frac{m}{n}AQ + \frac{m-n}{2n}BQ + \frac{m-2n}{3n}CQ + \frac{m-3n}{4n}DQ + \frac{m-4n}{5n}EQ + \&c.$$

which is exactly Sir Isaac Newton's Binomial Theorem.

For facilitating the exemplification of this celebrated theorem, it may not be improper to observe, that P is the first term of the binomial to be expanded; Q the second term divided by the first, namely, $\frac{PQ}{P} = Q \frac{m}{n}$, the index of the power or root.

$$A = P^{\frac{m}{n}} = \text{1st term of the series,}$$

$$B = \frac{m}{n}AQ = \text{2nd term,}$$

$$C = \frac{m-n}{2n}BQ = \text{3rd term,}$$

$$D = \frac{m-2n}{3n}CQ = \text{4th term,}$$

$$E = \frac{m-3n}{4n}DQ = \text{5th term, \&c.}$$

XLVI. *Remarks on the Gothic Ornaments of the Duomo, Battistero, and Campo Santo, of Pisa.* By ARTHUR TAYLOR, Esq. F.S.A., Member of the Roman Academy of Arcadians*.

THE Cathedral of Pisa, and its dependencies the Baptistery and Campo Santo, have become particularly known to the English antiquary, from the various opinions † which have been formed with regard to the genuineness of some of their details, and from the support they have been thought to give to one of the theories of Gothic Architecture. It will be the object of the present paper to record such observations upon the parts in question as the writer was enabled to make during his stay at Pisa in the present winter.

Of the three buildings, the first which will here be considered is the *Campo Santo*, being that upon which the most decided opinion has been formed. The *Campo Santo* may be briefly described as an open portico or cloister of four sides, composed of a light arcade of Roman architecture, the arches of which spring from square pilasters adorned with a base and upper cornice. These arches, which are all circular, contain the Gothic tracery whose originality or posterior addition forms the subject of dispute in the building before us. It was built from the design of Giovanni da Pisa, one of the most celebrated artists of the Pisan school; begun in the year 1278 ‡, and finished, according to the best authorities, in 1283; the Gothic work, it may be necessary to add, is of the rich and elaborate kind which is seen in the skreens of some of our churches, and particularly in an arch of the south transept of Norwich cathedral. The following are the remarks which occurred on a careful view of the interior.

First; That the marble of which the tracery is made is of a different kind from that used for the other parts of the fabric; the former being Carrara, the latter from the mountains of San Giuliano, near Pisa. Secondly; The Gothic work in question (which is sustained by a centre pier, two very slender round columns, and two half columns attached to the faces of the grand pilaster) is in every instance unconnected with the arch, and in more than forty of the arches day-light appeared between the half-pillar and the pilaster to which it is attached,

* From the *Archæologia*, vol. xx.

† See the controversy between Sir H. Englefield and Mr. Smirke, in the *Archæologia*, vol. xv.; also the Rev. W. Gunn's "Inquiry into the Origin and Influence of Gothic Architecture."

‡ According to the Pisan Chronology, which is a year later than the common style.

the fissure in some cases extending through a great part of the height of the pillar. The tracery which springs from these pillars diverges from a capital, corresponding in position, and generally in design, with the cornice which marks the commencement of the great circular arch. From this circumstance it is evident that the capital of the *half-pillar* should blend with that part of the cornice of the pilaster against which it is placed; this, if the whole work were of one time, would have been accomplished by forming the capital on the same stone with the cornice. The fact, however, is different; in fifty instances the cornice is cut, or rather broken away, to admit the capital of the half-pillar, and in twelve, the capital is cut at the top so as to fit it against the cornice. Of these two methods, the former (probably from the friability of the stone) is so very awkwardly practised, that the cornice is generally much dilapidated, and the capital (which is always perfect and entire) appears seated in a large irregular cavity. On the north side, indeed, it will be found that nearly the whole face of the cornice is sometimes destroyed; an effect certainly not produced by the injuries of time, and by no other cause than the mallet of a careless workman. Thirdly; In those arches, six in number, which form the passage ways to the inner quadrangle, or burial ground, a portion of the top of the pedestal in the great pilasters has been cut out and replaced by another piece formed to support and bind the half-pillar of the tracery; this operation, also, hath been performed with sufficient mal-adroitness to leave no doubt as to an alteration from the original plan of the building. It has been remarked that the capitals of the Gothic pillars correspond *generally* in design with the cornice of the Roman arch; it may be right to add, however, that the enrichments of the former are always more delicately cut, and that the similarity is merely that of a free imitation. From the facts now stated, it is evident that the Gothic tracery of the *Campo Santo* is **CERTAINLY** the addition of a later age: it only remains to fix the period at which the addition was made. For this purpose recourse will be had, without hesitation, to the tablet on the north side of the building itself,—an authority which has doubtless been cited and discussed in former dissertations, but which it may not be amiss to produce on the present occasion in a faithful copy from the stone*.

* The artist mentioned in the tablet is doubtless the Antonio Pisano of Muratori: "*Anno 1461, Antonius Pisanus, gemmarum pretiosorumque lapidum sculptura claret.*"

Whatever

✠ · D · FI ···· Ó · DE · MEDICIS ·
 ARCHIEPO · PISANO · ANTO
 NIVS · IACOBI · ALMI · TEMPLI ·
 PISANI · OPERARIVS · SACRI ·
 HVI² · ET · INTER · MORTALES ·
 PRECLARISSIMI · SEPVLCRI ·
 OPVS · I · I · I · ARCVBVS · XXVIII ·
 Q3 · PFORATIS · FENESTRIS ·
 MARMOREIS · I · I · I · ANN · SVA ·
 DILIGENTIA · PERFICI · CVR
 AVIT · D · I · AN · MCCCCLXIIII ·

Whatever difficulty there may be in understanding some parts of this inscription, in reference to the number of the arches, there can, it is submitted, be no doubt that its intention is to record the erection of perforated marble windows in the year 1464; and it is difficult to imagine what other objection can be made to the date assigned, than that,

according to a general theory, Gothic Architecture must have been discontinued at an earlier period. How far this opinion is supported by facts, will be left for future inquiry. One circumstance only will be noticed in *confirmation* of the date. It is known that the design of the patrons of this later work was to fill the arches with coloured glass; this, considering the vast size and number of the windows, it is not likely would have been attempted with the ancient *stained* glass composed of small pieces; it is therefore more reasonable to refer the work to an age in which the fabric of *painted* glass, in larger panes, was commonly known. With regard to the notice taken of the *Campo Santo* by Vasari, it may first be observed that his description is perfectly indefinite; but allowing it to be in hostility with the date assigned, it remains to be demanded whether the negative evidence, arising from his omitting to notice an alteration which took place eighty or an hundred years before his time, can be placed in opposition to the positive and authentic testimony which has just been advanced*.

To proceed to the *Battistero*: this magnificent structure was begun by Diotisalvi in the year 1153, Pisan style, and is for the greater part in the circular Romanesque manner which prevails through the whole of the *Duomo*, and characterizes most of the early buildings at Pisa. The LOWER story is adorned with large arches supported by Corinthian pillars, and is free from the slightest mixture of Gothic ornament. The SECOND is a range of smaller round arches, much re-

* Tronci says of the Campo Santo, "Non restò finito e perfezionato in tutto il magnifico edificio fino all' anno 1464, in tempo dell' Arcivescovo Filippo de' Medici, come si legge in un'altra iscrizione pure in marmo nello stipite del portone incontro la cappella della Barbaresca, hoggi de' Battaglini, nella faccia che mira verso il campo." *Mem. Ist. &c.* p. 234.

sembling those which are commonly found on our Norman churches: three of these occupy the place of one of the lower story. From the top of these arches, without any intervening cornice or line of separation, there rises a series of projecting canopies or pediments, alternated with lofty tabernacles and pinnacles. The THIRD story (commencing from a cornice behind the pinnacles) is occupied by windows, each formed of two lights divided by a munnion supporting two trefoil arches, under a circular arch. Between the windows are flat pilasters surmounted by small Gothic canopies, and above them, a pointed pediment or gable rising a little above the parapet. In the roof or *cupola* there are (on one side of the building) four apertures or windows adorned with pediments and crockets of a decidedly Gothic character.

From the description here given it will be evident that there exists in this building a great confusion of styles, and much to mislead the judgment upon a general cursory observation. It was, therefore, thought advisable to attempt a more close examination by venturing upon the cornice which runs round the exterior, at the commencement of the third story. In this place it was easy to touch the pinnacles which ascend from the arches below, and it was immediately found that the marble of which they are made differs from that employed in any other part of the fabric; the difference in colour may indeed be seen from below. It was observed, in going round, that the pinnacles were in no way so connected with the building as to have been necessarily erected at the same time; that they sometimes merely touch the cornice, sometimes stand clear altogether, and are sometimes let into it: in the latter case, it is plain, beyond all doubt, that the cornice was chipped or broken away *in situ*, the fracture proceeding from above. The angular pediments beneath could not be seen to advantage in this position. With regard to the trefoil windows and pediments of the *third* story, it was found that they certainly were ORIGINAL—speaking with reference to that story, the munnions and pointed arches binding in with the work. It is not to be assumed, however, that these parts, though of a Gothic character, are in the same style with the pinnacles above described. Plain in design, and simple in execution, they may be compared with specimens of the early pointed style in our own country, or with the half-Gothic style of Lombardy. The little canopies on the pilasters, and the apertures in the roof, appear to have the same character as the pinnacles.

Of the *interior* of the Baptistery we have chiefly to remark the simplicity and uniformity of its architecture, and its freedom from any the least mixture of the Gothic style, excepting,

of

of course, the glaring anomaly of one arch in the gallery, filled with rich tracery. This embellishment exhibits precisely the same appearances with the Gothic work in the *Campo Santo*, and is no doubt the beginning of an unfinished design of a similar kind, and of the same age. In the gallery which runs round the building, it may be observed that for some feet from the springing of the roof the side wall is continued with a new material, as if carried up at a later time. This change takes place just about that part where the trefoil windows are seen in the third story of the exterior. There are also traces of an intended groined roof, which would take its commencement from the termination of the old work. From these circumstances it may be inferred that the building was either left for a time unfinished, or that a former roof was removed for the purpose of giving it greater elevation: in either way the difference of style in the exterior is accounted for.

On a general review of the whole, the following were the conclusions, as regarding the exterior, which appeared least open to objection. That the work is composed in three different styles, the pure Romanesque of the first and second stories; the Lombardic, or mixed Gothic, of the third; and the Tedesque, or florid, Gothic, of the accessory details: and, secondly, that from the relative position of the several parts, it is probably the work of three different ages. In forming the division which has just been stated, the chief difficulty was found in regard to the pointed canopies above the small arches of the second story. Whether there be any objection to their being classed with the pinnacles with which they are connected must be left to a more competent decision; but inasmuch as concerns the possibility of their being additions, it will suffice to say, that no architectural embellishments can hang more loosely upon the fabric to which they belong.

It may not be uninteresting to accompany the foregoing details with a few historical notices; and in the first place to remark, that a current opinion relating to the Baptistery is, that it was begun and finished in the space of eight years, namely, between the years 1152, and 1160*. This opinion is justly condemned by Morrona, in his *Pisa Illustrata* †, who still, how-

* Thus Martini, in his *Theatrum Basilicæ Pisanae*, p. 93: “*Templum hoc fuit incæptum anno 1152, mense Augusti.—absolutum verò fuit anno 1160, ut eruitur ex quodam pervetusto codice in ejusdem primatialis Basilicæ Archivio existente.*” What this *codex* is, he does not condescend to inform us. So also Milizia, in his *Lives of the Architects*; “*Diotisalvi fu un architetto che nel 1152 edificò il Battistero di Pisa, e dopo otto anni lo terminò.*”

† Second edit. Leghorn, 1812.

ever, appears to consider the entire fabric as the design and work of one master, leaving the time of its completion to the conjecture or the research of his reader. The principal facts which this author has collected are, that the Baptistery was begun in 1152, or 53, according to the Pisan chronology; that the work was suspended for want of money after reaching the first or perhaps the second order, or story, of the exterior; and that it was continued by means of a voluntary monthly contribution from the inhabitants; adding that Dempster alone refers this levy to the year 1164. He also cites another historian, Roncioni, as saying that the first column to the east was set up on the first of October 1156, and that on the 15th of the same month the whole of the remainder, with the first vault, the pilasters and cornices, were erected and finished; an assertion which, with Vasari, may well be termed "*meravigliosa, e quasi del tutto incredibile*."

On reference to Tronci, the historian of Pisa†, little information was added to the scanty materials cited above. He says that the Baptistery was several years in hand ("*corsero parecchi anni a finirsi*"); that the first year the foundations were laid, and the first circle of the wall. More has, however, been gained from one of the old chronicles in the collection of Muratori; the following passages, which do not appear to have been cited by any modern writer, are not unworthy attention.

"Anno 1154. *Fundatus est primus gyrus ecclesiæ Sancti Johannis‡, Cionetto Cionnetti et Enrico Cancellario operariis existentibus. Qui Cionnetus in Sardiniam pluries ivit, et re-duxit de S. Reparata columnas.*"

"Anno 1159. *In quarto consulatu Cocchi, Pisani—tres columnas magnas pro operâ Sancti Johannis de Ylba ad dictam ecclesiam portaverunt.*"

"Anno 1164. *In calendis Octobris incipiendo in xiii. diebus octo columnæ in ecclesiâ Sancti Johannis erectæ sunt, de quibus unam unâ die in Porta Aurea erexit. Et tunc ordinatum est quòd unaquæque familia in singulis calendis mensium unum denarium ipsi operæ daret; et fundata est ecclesia Sancti Johannis Baptistæ§.*"

From this account it appears that the great columns which support the building did not arrive until five or six years after the commencement of the work, and that five years more had elapsed before they were finally erected; it is therefore a probable conclusion, that the fabric in question, so far from being

* *Vite, &c. Proem. p. 227-8, edit. Sanes.*

† *Mem. Ist. della città di Pisa, 4to, 1682.* ‡ The Baptistery, so called.

§ *Brev. Pis. Hist.—Rer. Ital. Script. vi. 168.*

completed by one architect, and in a short space of time, was continued with several interruptions, and carried on as the resources of the public treasury would permit.

Of the *Duomo*, in as far as the present question is concerned, little will need to be said. The only part of this vast pile which is involved in the controversy is the *corona*, or band of Gothic canopies which surrounds the drum of the dome. Here at least, no question can be raised as to the *possibility* of posterior addition; and as the work itself is of the same character as the ornaments of the Baptistery, the same opinion must be adopted respecting it. It is, perhaps, worth while to remark that the three courses of stone next under the *corona* differ from the inferior parts of the tower. As the ornaments upon the ledge of the grand pediment of the west front are said to have been mentioned as Gothic crockets, it may be permitted to express a different opinion; they are used for the same decorative purpose, but are surely more Grecian than Gothic, and are particularly characteristic of a style to which the appellation of *Greco-barbara* has been fitly applied.

The Church of *Santa Maria della Spina* having been cited as a work of Giovanni da Pisa in confirmation of the originality of the Gothic ornaments of the *Campo Santo*, some observations upon its history and architecture will now be added.

The Church, or rather Oratory of the *Spina*, called in old writings *Oratorium Sanctæ Mariæ de Ponte Novo*, was a little chapel standing at the foot of a bridge (since demolished) called *Ponte Nuovo*; the patronage of it belonged to the commonalty of Pisa, and hence it seems to have been regarded with partiality by the citizens. Its chief distinction, however, was conferred by the donation of a spine of Our Saviour's crown of thorns, said to have been brought by a merchant from beyond seas, and afterwards deposited in this chapel. The building, as it now appears, consists of a simple oblong room, with an extension at the east end forming the present chancel or sanctuary. This chancel, upon which rest the three spires (its principal ornament) is, without any doubt, a later addition, and is so termed by Morrona. The side next the street, and the west end, are both covered, as well as the chancel, with a case or skreen of pilasters, canopies, statues, pinnacles, &c. which, though not pure and correct, are nevertheless of the style which we should call florid Gothic. Upon examination they were found neither to correspond with what may be seen of the original work, nor to bind in with the masonry of the walls; their present dilapidated state is, indeed, a sad confirmation

firmation of this fact. The side that abuts upon the river remains in its original state, and is all of the Lombardic school. It is scarcely necessary to add, that the conclusion here formed was, that the church in its present state is the work of two very different periods. It only remains to examine its history, and the share which Giovanni da Pisa may be supposed to have had in its construction.

That the chapel was not *built* by this master is certain, if, as it is supposed, it was founded in 1230. Vasari, indeed, says expressly that the people of Pisa having something to do to the little church of St. Mary *della Spina*, confided the work to Giovanni (the time is about 1280); adding that he brought many of its ornaments to that perfection in which we now see them*. These ornaments Morrona supposes were the statues which adorn the original fabric, and adds that neither the first nor the second architect of the church is known.

It may now be permitted to indulge a few conjectures with regard to the history of the building before us. The donation of the relic already mentioned appears to furnish the best guide in the inquiry. As a common bridge-foot chapel, the oratory of St. Mary, plain as it was, suited the purposes for which it was intended; but when it had become the depository of so sacred a treasure, it was right that the exterior should assume a character of higher dignity and pretension; and the means of effecting this purpose being afforded by the destruction of the bridge, the chapel was enlarged upon what had hitherto been the public way, and the original fabric decorated in a corresponding style. The nearest approximation to the time of the supposed alteration will be derived from the following dates. The first notice of the relic adduced by Morrona is in the year 1433; but from an account of the procession of *Corpus Domini* in an old chronicle, it appears that it was existing in the chapel in 1362†. The *Ponte Nuovo* is thought by the same writer to have been pulled down soon after the year 1400. In 1454 a sum of money was granted for the restora-

* "—*avendosi a fare alcune cose nella picciola ma ornatissima chiesa di Santa Maria della Spina, furono date a Giovanni, il quale messovi mano, con l'ajuto di alcuni suoi giovani condusse molti ornamenti di quell' oratorio a quella perfezione che oggi si vede: la quale opera, per quello che si può giudicare, dovette esser in que'tempi tenuta miracolosa, e tanto più avendovi fatto in una figura il ritratto di Niccola di naturale, come seppe meglio.*"—Vasari, *Vita di N. e G. da Pisa*, p. 280. Niccola, the father, was well known to, and much respected by the Pisans.

† "E appresso con la ditta processione vi fù la Spina di Cristo, la quale li fue posta in capo alla sua passione, la quale Spina è nella chiesa di Santa Maria del Ponte Nuovo, &c.; Muratori, *Rev. Ital. Script.* tom. xv. col. 1036.

tion of the church: it is perhaps too much to assume this as the date of the Gothic details in question; but that they cannot be older than the time when the bridge was destroyed may be argued from the projection of the added part beyond the line of way between the opposite sides of the river*.

It will doubtless be said, in this case, as in that of the *Campo Santo*, that Gothic Architecture could not have been in use at so late a period. An extensive and minute research would be requisite to decide upon the truth of so general a position; but a few circumstances may shortly be noticed which appear to militate against it. There exists in Pisa itself a large and conspicuous red brick house†, which, if its date were known, would almost determine the question; it is covered with Gothic enrichments and pointed arches. On the floor of the Baptistery, at Pisa, is a sculptured tombstone with a Gothic canopy, dated 1395; in the church of Santa Caterina one of the same kind, dated 1403, and in the *Campo Santo* another, dated 1428‡. The *Palazzo Nerucci* in Siena, built in 1460, has pointed windows of two lights. Authorities to the same purpose might probably be collected even in Rome itself; it is remarkable, indeed, that the *Palazzo di Venezia*, one of the largest in that capital, which was built four years after the date assigned to the windows in the *Campo Santo*, namely in 1468, is but one remove from a Gothic building.

With regard to the period at which the pointed style was first employed at Pisa, a comparison of two of its principal churches may not be unimportant. The front of *San Paolo a ripa d'Arno* is ornamented in the upper part with three tiers of small arches, all round, and resembling those on the front of the *Duomo*, which was evidently the model for most of the ecclesiastical buildings in the city. This church is supposed to have been erected about the year 1100. The façade of *San Michele in Borgo*, built on the same plan, has three similar tiers of pointed arches, and of a character which we should call early Gothic; this was constructed in 1304. The front of *Santa Caterina*, which is also Gothic, and remarkably beautiful, would be a desirable addition to the list, but its date is uncertain.

In building his *Campo Santo*, it has appeared that Giovanni

* A person standing in the middle of the Via Santa Maria, at the end next the Lung' Arno, and looking across the river into the Via S. Antonio, will immediately perceive what is meant above.

† Well known as the Caffé del Ussero on the Lung' Arno.

‡ In the Galleries of Pisa and Siena are many pictures of the fifteenth century in decidedly Gothic frames; those which have dates are in 1440, 1447, 1453, and 1514: they are generally altar-pieces, and are fair indications of the architectural taste of their time.

da Pisa, so late as the year 1278, adopted a Roman style. It is not, however, to be concluded, on this account, that the Gothic was then entirely unknown. It occurs in a mixt and irregular form in the pulpit of the Baptistery, made by his father Niccolo da Pisa in 1260; but an earlier specimen, of authentic date, has in vain been sought for.

Having now detailed the principal observations made in a survey of the interesting buildings which form the subject of the present Paper, the writer has only to state the result of an inquiry respecting them, undertaken at the desire of a highly respected friend to whom the public is indebted for a very learned and ingenious work on the architecture of the middle ages.

The Rev. Mr. Gunn having, three or four years since, applied to a gentleman resident in Tuscany, to obtain for him the sentiments of the best Pisan architects with regard to the disputed Gothic ornaments, received an answer professing to contain the opinion of Signor Antonio Toscanelli, an artist of great respectability at Pisa, which not only explicitly declared in favour of the entire originality of these parts, but asserted the existence of original plans and designs of each of the buildings in the Archivio of Pisa corresponding exactly with their present appearance. To this communication, the most important that could have been received to the question at issue, and apparently resting on the best authority, Mr. Gunn of course assigned a place in the work above referred to, and made a further application, through the same channel, with a view to get copies of the designs themselves. To this request he had not been able to obtain a satisfactory reply; till, upon the present investigation, it appeared that the opinion so derived was not only fictitious, but in opposition to the judgement of the person to whom it was attributed. Signor Toscanelli believes that no designs, such as were stated in it, exist, and naturally expresses his astonishment that any one should have presumed to make use of his name on such a subject, without his knowledge and authority. The real opinion of the Pisan antiquaries is, indeed, of a very different kind. In particular the Cavaliere Lasinio, to whose polite attentions the writer is much indebted, is fully persuaded of the posterior addition of the Gothic attributes; and concurs generally in the conclusions above stated.

It will be right to add that the foregoing remarks have been written without access to the memoirs which have already appeared on the subject in the volumes of the *Archæologia*; the writer had indeed no other guide to the points of principal interest, than an abstract of the controversy by the friend of whom

whom he has lately spoken, and from whose judgement concerning them he has most reluctantly been compelled to dissent.

Rome, March 30, 1822.

ARTHUR TAYLOR.

XLVII. *On the Local Attraction of Vessels.*—*In a Letter from Admiral KRUSENSTERN of the Imperial Russian Navy to PETER BARLOW, Esq. F.R.S.*

Dear Sir,

St. Petersburg, July 8, 1824.

I HAVE had the honour to receive the letter you have done me the favour to address, dated April 22d, with a copy of your work to be presented to the Academy of Sciences, and six copies of your Appendix; three of which I have sent according to your desire to Admiral Greig, commander in chief of the Russian marine station in the Black Sea, who has requested me to return you his obliging thanks for your kind attention; and he is very anxious to have a compass made by Messrs. Gilbert with one of your correcting plates, tables, &c.

Since I have had your letter, I am happy to learn by the public papers, that the Board of Longitude and Trinity Board have rewarded you for the ingenious discovery you have made. After the many experiments by such skilful officers as Captains Basil Hall, Owen, and others, published in your work with their highly satisfactory results, the value of your discovery so highly important to the interest of navigation does not stand in need of any other testimony. It has, however, been long my wish to have these experiments made here also, being firmly convinced since what I read in the part of the work you sent me last year, that no ship should go to sea without this excellent method of neutralizing the deviation. It may perhaps be no where of so great use as in the narrow seas of the Baltic, where the navigation, late in the season, notwithstanding the excellence of our light-houses, is extremely dangerous, and where an error of some degrees in the course steered during a night of 14 or 15 hours' duration, must frequently bring the ships into danger. It is of equal importance for ships coming from Archangel, steering almost all the way a course which is known generally to be affected considerably by the iron in the vessel.

I had ordered last year a compass from Messrs. Gilbert, but it arrived during my absence, and on my return to Petersburg it was too late to have the observations made. Ill health prevented me from going to Cronstadt early in the summer, so that it was not till the 1st of July that I went down with

Admiral Count Heyden, an officer of high scientific attainments, and equally interested with me to learn the results of these observations. M. Chalizoff, a master in the navy, went with us, who had been already employed by Count Heyden when commanding at Sweaborg to make observations on the deviation of the compass. The governor of Cronstadt, Admiral Moller, brother to the minister of marine, gave immediately on our arrival an order to the commander of the *Olynip*, a brig of war mounting twenty twenty-four pounders, to warp the ship according to my directions, and at 4 o'clock the next morning we commenced our experiments, of which I shall give you as detailed an account as possible, requesting you to communicate such remarks as you may find requisite to make on them. Not having a theodolite to observe the bearings of the ship from shore, we compared the compasses we had to make use of, and found a difference, between the Gilbert compass and the azimuth compass belonging to the ship, of three-fourths of a degree, which difference has always been applied. The brig being very high fore and aft, it was very difficult to place the stand of the compass conveniently for the observer: at length we placed it in the after part of the ship on the starboard side on the top of a small cabin*. It was equally difficult to fix upon a spot on shore to take the bearings, from the Roads of Cronstadt being every where surrounded by large batteries, where on account of the guns the observations could not be made. The only spot that could be selected was the end of a bridge opposite to the ship, at the distance of about half a mile. M. Chalizoff, a very expert and careful observer, was sent on shore with the ship's azimuth compass, while Count Heyden and myself remained on board. The ship was now warped round the compass to every point, and sometimes to less, as you will perceive by the original observations which I herewith inclose. As soon as the ship was swung and steadied, a signal flag was hoisted on board, and repeated on shore; then both observers keeping the two flags on board and on shore in the same line of sights, three bear-

* It is to be regretted that it was necessary to place the compass in this situation, because, being elevated and further aft than the usual place, there is no doubt the errors observed were much less than they would have been in the natural situation for the azimuth. In all probability they would have been increased from a half to at least three quarters of a point, or 7° or 8° .

The difficulty here noticed, of not being able to see the shore station from the ship, has occurred in some English vessels where the bulwarks have been very high, and in vessels with poops. The best way in these cases is for the two observers (instead of taking each other's bearing) both to take the bearing of the sun by signal at the same instant, then the difference in these bearings will be the local attraction.—P. B.

ings were taken, and the mean adopted as the correct one (the difference being always very inconsiderable), the master of the ship taking at the same time the bearing of the ship's head by an azimuth compass; the flag was then hauled down on board and immediately repeated on shore.

As soon as the ship had been warped quite round the compass, we went on shore with the plate; and on comparing our several bearings, we found that it was at south 4° east that they coincided nearly; this then was the point in which the iron of the ship had no influence on the magnetic needle, or the line of no attraction. We now proceeded to apply the correcting plate to the compass, trying to obtain its right position, viz. its distance from the compass and its depth below the pivot of the needle, which was ascertained and measured. We then returned to the ship, and in order to have a proof of the exactness of the results of our experiments, we took with the plate compass the bearing of the object on shore we formerly had observed without the plate, and found it to be correct within a quarter of a degree.

The Minister has now ordered the same observation to be made on board the ship that is to sail to the South Seas, commanded by Captain Doxturoff, one of our best officers in the navy, who will on his arrival in England provide himself with one of Gilbert's compasses and a plate, and he will not fail to communicate to you the results of his experiments as soon as they are made, but the ships are not yet in the Roads.

As these are the first experiments of the kind made here they may be liable to some imperfections, which however will soon be got over.

Before I conclude this letter permit me to return you my best thanks for your letter of the 7th of February, accompanied by your directions for using the plate, of which I sent a copy to Admiral Greig without delay, who takes a great interest in your valuable discovery, and will not fail to have those experiments repeated as soon as he gets one of the plates.

I have the honour to be,

With high esteem and regard,

Yours, very truly,

(Signed) KRUSENSTERN.

286 Admiral Krusenstern on the Local Attraction of Vessels.

Experiments made to ascertain the quantity of local attraction in H. I. M. S. Olynip, made on the 2d of July 1824, in the Roads of Cronstadt, by Admirals Count HEYDEN and KRUSENSTERN.

Bearing of Ship's Head.	Bearing of Shore Station from Brig.	Bearing of Brig from Shore Station.	Local Attraction.	Bearing of Ship's Head.	Bearing of Shore Station from Brig.	Bearit. of Brig from Shore Station.	Local Attraction.
N 10° E	N 26° 40' E	S 28° 15' W	-1° 35'	S 9° W	N 30° 20' E	S 29° 45' W	+0° 35'
20	26 40	28 30	-1 50	25	30 20	29 30	+0 50
30	26 20	29 15	-2 55	33	30 40	29 45	+0 55
49	25 40	29 15	-3 35	66	31 00	29 00	+2 00
53	25 40	29 15	-4 5	86	31 00	29 00	+2 00
63	25 20	29 45	-3 55				
73	25 40	31 15	-5 35	N 78 W	30 45	28 45	+2 00
				70	31 20	28 45	+2 35
S 86 E	26 00	31 15	-5 15	60	30 40	28 30	+2 10
70	26 20	31 15	-4 55	51	30 40	28 45	+1 55
55	27 20	31 45	-4 25	45	31 00	28 45	+2 15
45	27 40	31 45	-4 5	36	30 20	28 15	+2 05
35	28 20	31 15	-2 55	25	29 40	28 15	+1 25
27	28 50	31 15	-2 25	20	28 40	28 15	+0 25
15	29 20	31 15	-1 55	9	26 40	27 30	-0 50
5	30 00	30 15	-0 15	3	26 40	27 45	-0 55

NOTE.—It gives us much pleasure to see this highly important nautical improvement making such rapid strides towards being generally adopted. Our own ships of war are in future all to be supplied with a correcting plate, and we understand that both the Dutch and American marine have ordered plates for the purpose of experiment and correction. Our merchant service will, we have no doubt, soon follow these examples. In the mean time, in order to accelerate as much as in our power this desirable practice, we publish, with Mr. Barlow's permission, the following letter which he has received from one of our most distinguished naval Boards, whose opinion will, we have no doubt, have a powerful influence in recommending the adoption of the principle by the more respectable class of our merchant vessels, as that of the Longitude Board has been the means of introducing the practice into the navy.—EDIT.

Copy of a Letter from J. Herbert, Esq. to Mr. Barlow.

Sir,

Trinity House, London, 17th June 1824.

The General Court of this Corporation having had under consideration the importance and utility of your discovery of a method for correcting the local attraction and consequent deviation of the compass on ship board, and being of opinion that the practice of the science of navigation will be greatly benefited,

benefited, and the security of all classes of shipping very materially promoted thereby,—I have it in command to acquaint you, that it has been resolved to present you with the sum of two hundred pounds, as a mark of the high sense the Elder Brethren entertain of the merits and practical utility of so important a discovery.

I am, sir, &c.

To Peter Barlow, Esq.

J. HERBERT, Secretary.

XLVIII. *A Sketch of the Progress of Science respecting Igneous Meteors and Meteorites during the Year 1823; including an Account of the principal Phænomena of that Nature observed during the same Period: with Inquiries suggested by those Subjects.* By E. W. BRAYLEY, junior, A.L.S., and Member of the Meteorological Society.

[Continued from p. 119.]

TO return, however, to the phænomena of the American meteor itself:—Professor Dean, after determining the angular values of the observations made upon it by Capt. Wardner and Col. Page, proceeded to calculate from them, according to the rule given by Dr. Bowditch, its actual situations when they were made, and thence the direction of its motion; with its altitude, absolute diameter, and velocity. The direction of its path, as already stated, he found to have been south 34° west: at its first brilliant coruscation, as observed by Capt. W., it was about forty-one miles above the earth, or according to Col. Page, only thirty-four; over the unsettled part of Essex county, New-York, about fifteen miles west of Crown-point; lat. $43^{\circ} 54'$, long. $73^{\circ} 47'$: at its disappearance from the former gentleman, behind the ridge of a house, its elevation appeared to have been about twenty-nine miles; over the western part of Schoharie county, in lat. $42^{\circ} 45'$, long. $74^{\circ} 49'$. “But altitudes estimated under the impression which such a phænomenon cannot fail to produce,” Prof. Dean justly observes, “must be considered as very uncertain, whatever may be the judgement and fidelity of the observers.” He then states the length of the meteor’s path, as probably determined from these observations; which has likewise been given in a former page of this memoir.

“I hardly dare,” he continues, “to make any estimate of its velocity. I have heard no estimate of the duration of the appearance of the body of the meteor greater than five seconds; and this would imply a velocity much greater than that of the Earth in its orbit.” At Salem, in Washington county, New-York, however, where the observers do not appear to have witnessed

witnessed the explosion, and by whom, consequently, the body only of the meteor is spoken of, it is stated to have been visible for about one minute; so that the time of its passage may probably have been under-rated in the estimates alluded to by Prof. D.: although, on the other hand, common observers of such phænomena usually attribute a greater length of time to their duration than they really occupy; and several other Fire-balls on record appear to have been impelled through the atmosphere with a velocity nearly equal to that assigned to this one by Professor Dean.

Professor Dean gives two measures of the apparent diameter of this meteor, both obtained by comparison, at the time of its passage, with stationary objects; and which differed from each other only two degrees; Capt. Wardner's object of comparison indicating it to have subtended 10° , and Col. Page's 12° . Its absolute diameter, computed from these, and from the mean distances of the observers respectively, "amounts," he states, "to about one-third of a mile." Considering the immense magnitudes which former meteors have been shown to possess;—that Montanari calculated the smaller diameter of that which passed over Italy in 1676 to have been above half-a-mile; that Halley computed the diameter of the fire-ball of 1719 at a mile and a half; and that Cavallo and Blagden determined that of the celebrated meteor of 1783 to have been between half and three-fifths of a mile;—the size thus ascribed to the American meteor does not appear to be excessive.

But various phænomena displayed by this meteor, indicate, I think, that we are to consider the one-third of a mile to have been merely the approximate diameter of the mass of flame, in which the solid matter or substance of the meteor was enveloped; so that the latter may have been, (and no doubt it was,) of much smaller dimensions. Thus Mr. Doty states, that "*the blazing meteor* was in full view over his head, appearing to be twenty or thirty feet in diameter, and soon began to extend itself to the north-east and south-west, increasing in extension, and decreasing in its flaming appearance, until nothing was to be seen but two detached parts of it rapidly moving in different directions towards the north-east and south-west." Col. Page affirms, as before stated, that when it was "about one-third of the way from Procyon to Sirius it suddenly broke out in great splendour, and continued its course flashing and sparkling east of Sirius," until it disappeared. And as neither the different distances of these and other observers from the meteor, nor the allowances necessary to be made in drawing inferences from common estimates of the apparent diameter of such bodies, are sufficient to reconcile the great discrepancies

in their statements on this subject; those discrepancies must have arisen, I conceive, from the circumstance, that the disk of the meteor actually varied in size at different periods of its course; and variation to such an extent as is indicated by them, in so small a space of time as that occupied by the passage of this fire-ball, could only have taken place in ignited gaseous matter, or *flame*, proceeding, however, from the combustion of solid matter.

Such are the grounds on which I have founded the opinion above given of the nature of this meteor; and as the assumption that the magnitude of fire-balls as computed from their distance and apparent diameter, is the actual size of the solid mass they contain, appears to have led to various misconceptions regarding them, I shall take this opportunity of submitting, with much deference, a few facts, tending to show that the magnitude of fire-balls so computed, is in no case that of the substance of the meteors; but merely of the flames with which they are invested. I am not prepared to assert that this distinction has been overlooked by every writer on the subject; but it is within my knowledge that it has been neglected by many; and that others, who seem to have had some idea of its existence, have nevertheless derived much less use from it, in their inquiries concerning the origin and theory of such phenomena, than it appears to be capable of affording.

Thus Dr. Bowditch, in his excellent account of the meteor that exploded over Weston, in Connecticut, on the 14th of December 1807, after stating that "the least of all the limits of the diameter of the meteor is 491 feet;" proceeds to compare, in the following manner, the quantity of matter which that dimension would indicate it to have contained, with the actual weight of the stones that fell from it: "A body of this magnitude," he says, "and of the same specific gravity as the stone that fell at Weston (which weighed about 225 pounds to a cubic foot) would contain a quantity of matter exceeding in weight *six millions of tons*. If the specific gravity were the same as that of the air at the surface of the Earth, the quantity of matter would exceed *two thousand tons*: and if the specific gravity were the same as that of the air at the height of the meteor (which by the usual rule for barometrical admeasurements is about $\frac{1}{38}$ th part of that at the surface of the Earth), the quantity of matter would exceed *fifty tons*. Either of these estimates exceeds by far the weight of the whole mass that fell near Weston, which, by the accounts published, does not appear to have been greater than half-a-ton, and would not form a sphere of two feet diameter of the same specific gravity as the stone, as was observed by Professor Day, in his valuable

paper on the origin of meteoric stones. A sphere of this diameter, seen at the distance of the meteor from Wenham, would hardly be visible without the assistance of a telescope, since its apparent diameter would not exceed two-thirds of a second. These reasons seem strongly to favour the opinion, that by far the greater part of the mass continued on its course without falling to the Earth, and the gradual disappearance of the meteor, as observed by Judge Wheeler, is agreeable to this hypothesis*."—But how different an aspect will these circumstances assume, and how different will be their bearing on theoretical inquiries, if it can be shown that we must consider the visible meteor to have been principally a mass of flame, proceeding from a solid nucleus comparatively small? I do not intend, in this place, to enter into the subject of the theory of these meteors; but shall merely endeavour to prove that it cannot be investigated, without the application of a correction for the probable difference between their size, as computed from their apparent diameter, and that of the mass of solid matter which they may respectively contain.

The chief phænomena of Bolides from which I am disposed to infer that they consist, essentially, of a nucleus of combustible solid matter, from which arises a body of flame of vastly superior magnitude, are the following: First, the characteristic appearances of inflammation which some of these meteors are said to have presented; particularly those, which, by descending comparatively low in the atmosphere, have approached the nearest to the spectators: secondly, the frequently ovate figure of their disk, indicating their spheroidal form, with the longest axis in the direction of their motion: thirdly, the change of form which many have been seen to undergo during their progress through the heavens; a change, which in various instances cannot have been merely an optical deception, produced by the different aspects under which the meteors were successively viewed: fourthly, the *tails* which by far the greater number of fire-balls have been seen to draw after them, and from which, by some observers among the ancients, and by the uninformed in modern times, they have been occasionally confounded with comets: and fifthly, the luminous traces, often in a continuous band, or *track*, as it has been termed, and sometimes remaining for many minutes after the meteors' disappearance, by which their path in the heavens has in a variety of cases been marked; and which, in conjunction with their caudate appearance, have caused many observers to compare them to immense sky-rockets.—I pro-

* Nicholson's Philosophical Journal, vol. xxviii. p. 218: from the Memoirs of the American Academy.

ceed to adduce a few of the more striking cases in which some of these phænomena have been displayed; selected from an extensive collection of similar materials now before me.

The appearances of inflammation that have been ascribed to various fire-balls, being phænomena respecting which there may exist some doubt; as they may possibly arise from deceptions of some kind, it would be unphilosophical to place any reliance upon, in support of the opinion I have advanced; and yet the following instances, among others, seem to have been observed with sufficient accuracy to warrant my bringing them forward as at least collateral evidence.—The meteor seen in Italy, on the 25th of March 1719, is described by Balbus as having been “*Globus igneus*”, a Ball of Fire; and “*apparebant in eo*,” he states, “*hiatus, seu voragine quatuor fumum exhalantes; flammulæ etiam ardentes quamplurimæ, quarum aliæ in ipso globo insidebant, aliæ foras mittebantur**.” The meteor which threw down the celebrated shower of stones in the vicinity of Siena in 1794, as described by Soldani, but at too great length to quote on the present occasion, had the strongest appearance of being a flaming body; the vapour which issued from it giving it the character of a cloud; as was likewise the case with that which produced the tremendous shower at L’Aigle in 1803. A brisk scintillation, like that of a fire-brand carried against the wind, was observed about the body of the meteor from which descended the shower of stones at Weston, in Connecticut, in 1807.—When the fire-ball beheld in London, on the 13th of November 1803, increased in brilliancy, and became ovate in form, about a second or a second and a half before its disappearance, “it seemed,” Mr. Firminger states, “as if the meteor had before been covered with one external coat, which now burst or separated in the middle the whole length of its longest diameter, and exposed a surface with a brightness far surpassing its former lustre†.” This appearance, also, I conceive, could only have been produced by an inflamed body undergoing intense combustion.

The instances of Bolides having a spheroidal form, with the longest diameter in the direction of their motion, are too numerous, and too well known, to need recital here; and the inference to be drawn from them, with regard to the nature of the meteors is too obvious to require pointing out.

Evident proofs of actual and considerable variation, in form as well as in size, are afforded, I think, by nearly all the detailed accounts of large Fire-balls that have been published:

* *Commentarii Bononienses*; tom. i. c. 285. † *Phil. Mag.* vol. xvii. p. 279.

by Sir John Pringle's collection of observations on that which appeared in 1758, for example; by Dr. Blagden's memoir written on occasion of that of 1783; and likewise by the observations on the American meteor of 1822, of which I have already given a summary.

The elongation of the flames enveloping the nucleus of meteors, from the resistance of the atmosphere to their immense velocity, seems to produce the caudate appearance, always in the direction opposite to that of their motion by which the majority of them are characterized; and from which also they have been described as conical and pear-shaped, and compared in figure to trumpets, &c.; cases of this sort it would be superfluous to adduce, as every memoir upon the subject is replete with them.

The same may be said of the luminous tracks which are so frequently left in the atmosphere by meteors of this description; and several instances of them have already been noticed in this paper. They appear scarcely explicable but on the supposition that they consist of ignited solid matter in a state of minute division, and resulting from the combustion going on in the meteors whose aerial course they distinguish.

I have stated, at the outset, my reasons for bringing forward the foregoing brief statement and cursory illustrations of the opinion respecting the nature of Bolides, which the comparison of a variety of accounts of them has induced me to form: the subject involves many others, and some of great interest: such, for instance, as the determination of the species of combustion going on in these meteors; the data for which are the phenomena with regard to the evolution of light and heat of the fire-balls themselves, the nature of the substances cast down by their explosions, and the results of Sir H. Davy's 'Researches on Flame.'

The examination of these subjects, however, I must reserve for another place; and with merely an allusion to the bearing of the question on which I have endeavoured to support an opinion, upon the comparison of the computed magnitude of any one meteor with that of another (see p. 116.), and also on the great variation in apparent diameter of the same meteor as seen by different observers (*ibid.*), I will conclude this digression; and proceed with the historical review of the progress of science respecting igneous meteors during the past year.

M. Moreau de Jonnés, to whom science is indebted for much information respecting the climate, physical geography, and natural history of the West Indian Islands, communicated to the Royal Academy of Sciences of Paris, on the 30th of December 1822, an extract of a letter from Fort Royal, in Martinique

inique; relating the passage of a meteor over the island, at eight in the evening of the 1st of September in that year. When this took place, the sky was covered with clouds in rapid motion: the meteor was of considerable magnitude, and having been seen advancing over the Caribbean sea for several minutes, proceeded with extraordinary velocity from west to east, towards the coast of the island. It is stated to have produced, during its passage, a noise resembling the rolling of thunder; and to have exploded, at the instant which preceded its disappearance, with an extremely violent detonation. The terror it caused among the inhabitants was so great, that some of them swooned away, and others were seized with illness*. M. Moreau de Jonnés observes, at the conclusion of the notice, "It is to be wished that this phænomenon had been observed at other places, in a more precise manner: it must however be remarked, that, supposing it to have been the fall of an aërolite, of which we have yet no instance in the American islands, there is but little hope of obtaining decisive evidence to that effect, in an island deeply penetrated by inlets of the sea, and more than half covered with forests†."

I may here remark, that a paper in vol. xxx of the Philosophical Transactions, by Mr. Henry Barham, F.R.S., affords distinct evidence of the fall of a shower of meteorites near St. Jago de la Vega, in Jamaica, about the year 1700; although the writer was not aware of the fact; the observers not having had the curiosity to dig up the stones, though they endeavoured to probe the deep holes in the ground which had been produced by their fall.

Mr. Davenport has published a notice of a Fire-ball seen by him, whilst travelling northward on the Hastings road, on the 28th of October 1822. He was slowly ascending Silver Hill, which is about forty-eight miles south-east of London, by road measurement, at about half-past five in the afternoon: the sky being clear, the moon nearly full, and shining bright, the sun below the horizon, but the twilight still strong; when he beheld the meteor in the north-east, and at the altitude of about 22° , by estimation. It was fully equal to one-third of the apparent diameter of the moon when at full; and gave a remarkably bright and white light. It passed towards the west in a horizontal direction, the length of its path while it continued visible being above 20° , which it occupied about eight seconds in traversing. It disappeared from Mr. D. by passing

* May we infer from these circumstances that the meteor was very near the island at the time of its explosion; so that the report and concussion of the atmosphere were experienced in an intense degree by the parties thus affected?

† *Revue Encyclopédique*, vol. xvii. p. 191.

behind a loaded waggon. He published his observations with the view of their being compared with those of other persons who might have seen the phænomenon ; but no further account of it has appeared*.

I shall close this part of the subject with a fact of my own observation. On the night of the 10th of December 1822, whilst walking near the top of Goswell Road, Islington, I beheld, at about half-past eleven, a very beautiful caudate meteor, its general shape much resembling that of a trumpet ; to which the smaller fire-balls of this kind have been frequently compared. The head, which had a sort of burr around it, appeared to be of about one-third of the diameter of the full-moon, and was of a very brilliant white colour, with a tinge of blue: the tail, which was very long, was also white at the upper end, but of a full red colour for the lower and greater portion of its length ; a circumstance, likewise, which has often been noticed in meteors of this description. The meteor darted down from near the zenith in a north-westerly direction, for about 30°, the wider part seeming to become attenuated into the tail, which disappeared in a few seconds without leaving any track or other traces in the sky, then clear and star-light. A similar phænomenon, I was subsequently informed, had been witnessed on the night of Nov. 5 ; and another on that of Dec. 7.

Dr. T. Forster, F.L.S. and Member of the Meteorological Society, has published a third edition, corrected and enlarged, of his "Researches about Atmospheric Phenomena;" but the chapter on Igneous Meteors and Meteorites, and the observations on those subjects in that on Electricity, remain as they were in the second edition, published in 1815: the Calendar of Nature, however, which the author has now appended to his work, records some observations on Shooting Stars. He remarks that those meteors are very prevalent about August ; particularly with east winds.

In No. III. of Gilbert's *Annalen der Physik*, for 1823, is an announcement by Professor Brandes, of Breslau, of the hours at which observations would be made on the same interesting phænomena, at Quedlinbourg, Halle, Liegnitz, and Breslau, during the year: I am not aware that the observations have been published. Prof. B. has furnished meteorologists, at various times, with many useful observations on the altitude, velocity, and magnitude of shooting-stars.

Signor Angelo Bellani, of Pavia, a philosopher who has become advantageously known to meteorologists by his announcement and subsequent investigation of the depression

* Annals of Philosophy, N. S. vol. v.

which in time takes place in the freezing point of thermometers, has published a memoir on Shooting Stars, in which he supports the theory, that those meteors are caused by the combustion of trains of inflammable gases or vapours in the atmosphere. He thinks that such trains may exist in the higher regions without being dissipated, in consequence of the general and perfect tranquillity which may be considered as reigning there: and he endeavours to combat the difficulty generally urged against this theory,—the diminished inflammability by expansion of gaseous or vaporous mixtures,—by referring to the vapour of phosphorus; stating, “that phosphorus becomes luminous, or suffers a slow combustion, at a temperature so much the lower as the quantity of oxygen gas in a determinate space is rendered smaller, either by mixture with other gases, or by rarefaction.” He then ventures the conjecture, that there may be other substances, capable by natural operations of being reduced to the state of vapour or gas, and which, though not inflammable at common temperature and pressure, may become so by being elevated in the atmosphere*.

[To be continued.]

XLIX. *Reply to Mr. SAMUEL COOPER'S Queries on finding the exact Mean Solar Time.*

To the Editors of the Philosophical Magazine and Journal.

Gentlemen,

IN the last number of your Magazine, pages 210 and 211, there is a curious solution of Mr. Samuel Cooper's for finding Mean Solar Time by an altitude of the sun, taken with a reflecting circle and an artificial horizon: also some queries as to the accuracy of his method, &c. I beg to observe that although it appears to me to be rather an awkward and far-fetched form, involving unnecessary trouble, yet with the reduced latitude, as Mr. C. terms it, the sun's reduced declination, and his true altitude, he has succeeded in bringing out the mean time within 1^s.6 of what it is by the first method given in the third edition of Mackay's work on the Longitude, &c. page 126; or by the second method in Norie's Navigation. He will find either of these methods shorter and more expeditious for finding apparent time, at the same time they are better known by mathematicians. Mr. Cooper's phrases, “*apparent* and *visible* latitude, and *visible* altitude” are not scientifically expressed; therefore they ought to be avoided, to prevent any ambiguity in the expressions of their sexagesimal quantities. From the substance of the question I make the latitude of

* Journal of Science, &c., vol. xv. p. 391.

Pertenhall, Kimbolton, rather more than a mile under Mr. C.'s reduced latitude. But to obtain the true latitude by an altitude of the sun, the apparent time should be known to be correct, and not exceed forty minutes before or after noon.

I have myself been in the habit of taken altitudes of the sun and stars with a sextant and an artificial horizon, for ascertaining the daily rate of ship chronometers and an astronomical clock. For this purpose I have tried many fluids, as water, oil, treacle, as circumstances have required, and find that quicksilver strained through a piece of soft shammy leather, and thus cleansed from dross and dust, is the best that can be used for defining the limbs of the sun, &c. by direct and reflected vision. Yet by this process I despair of ever obtaining the apparent time to the fraction of a second: if it can be got to a second of time, I deem it an excellent observation, considering the discrepancies there may be between the tabular atmospherical refraction, after correcting it for pressure and temperature, and the real refraction in the day-time, with the probable error of the instruments after their adjustment.

The method universally adopted by practical astronomers to find the apparent time, and thence the error of a chronometer or clock, when they are not provided with a transit instrument fixed in the meridian, is by equal altitudes of the sun, or a known fixed star; for by this method, the process of which may be found in most treatises on navigation, neither the accuracy of the latitude of the place, nor that of the declination of the celestial object particularly depends, since the elements are only necessary in taking out the equation of equal altitudes.

With respect to double altitudes on shore, I have often found the latitude by meridional altitudes of the sun and known fixed stars, far more correct than by two altitudes taken out of the meridian by the most accurate methods that have yet been adopted. I therefore prefer a meridional altitude, particularly of the sun as the largest object, for ascertaining the latitude; and equal altitudes for apparent time.

Not the apparent, but the *true* altitude of the sun's centre should be invariably used for finding the apparent time; and thence the error of a chronometer or watch, by applying the equation in its proper sign, after it is reduced to the time of observation.

The sun's right ascension as given in the Nautical Almanack, is expressed in *apparent solar time*, not in sidereal time.

The application of the quantities in Dr. Tiarks's tables alluded to by Mr. C., is for the stars only, as an easy method of reducing sidereal into mean solar time. Had Dr. Tiarks furnished you with two tables instead of his table No. 2, one for

for reducing sidereal into mean time, the other for reducing mean into sidereal time, to any instant required, they would have been an acquisition in stellar calculations, and found to be more generally useful than his.

In order to obtain apparent solar time by an observed altitude of a known star, nothing more seems necessary than to reduce the sun's right ascension to *apparent time* of observation, and apply a correction for longitude (if any) from the meridian of Greenwich. The right ascension and the polar distance of the star, if it be one of the 24 in the table of stars at the end of the Nautical Almanack, may be taken out for the given day by inspection at once, as the variations in 24 hours under these circumstances seldom amount to an appreciable correction, except for *Polaris*. Then to the apparent time found by the method in Mackay's, Norie's, or Riddle's Navigation, apply the reduced equation of time in the same sign as expressed in the Nautical Almanack, the result will be the mean solar time, at the place of observation, when the altitude was taken; the difference between this time and that shown by the chronometer or clock, will be the error sought.

The following are the tables I have alluded to, with an example to each.

Table for Reducing Sidereal into Mean Solar Time.

Hours.	Equa.	Min.	Equa.	Sec.	Equa.
	m. s.		s.		s.
1	0 9.83	1	0.16	1	0.00
2	0 19.66	2	0.33	2	0.01
3	0 29.49	3	0.49	3	0.01
4	0 39.32	4	0.66	4	0.01
5	0 49.15	5	0.82	5	0.01
6	0 58.98	6	0.98	6	0.02
7	1 08.81	7	1.15	7	0.02
8	1 18.64	8	1.31	8	0.02
9	1 28.47	9	1.47	9	0.02
10	1 38.30	10	1.64	10	0.03
11	1 48.13	11	1.80	11	0.03
12	1 57.96	12	1.97	12	0.03
13	2 07.78	13	2.13	13	0.04
14	2 17.61	14	2.29	14	0.04
15	2 27.44	15	2.46	15	0.04
16	2 37.27	16	2.62	16	0.04
17	2 47.10	17	2.78	17	0.05
18	2 56.93	18	2.95	18	0.05
19	3 06.76	19	3.11	19	0.05
20	3 16.59	20	3.28	20	0.05
21	3 26.42	21	4.91	21	0.08
22	3 36.25	22	6.55	22	0.11
23	3 46.08	23	8.19	23	0.14
24	3 55.91	24	9.83	24	0.16

Table for Reducing Mean Solar into Sidereal Time.

Hours.	Equa.	Min.	Equa.	Sec.	Equa.
	m. s.		s.		s.
1	0 9.86	1	0.16	1	0.00
2	0 19.71	2	0.33	2	0.01
3	0 29.57	3	0.49	3	0.01
4	0 39.43	4	0.66	4	0.01
5	0 49.28	5	0.82	5	0.01
6	0 59.14	6	0.99	6	0.02
7	1 08.99	7	1.15	7	0.02
8	1 18.85	8	1.31	8	0.02
9	1 28.71	9	1.48	9	0.02
10	1 38.56	10	1.64	10	0.03
11	1 48.42	11	1.82	11	0.03
12	1 58.28	12	1.97	12	0.03
13	2 08.13	13	2.14	13	0.04
14	2 17.99	14	2.30	14	0.04
15	2 27.85	15	2.46	15	0.04
16	2 37.70	16	2.63	16	0.04
17	2 47.56	17	2.79	17	0.05
18	2 57.42	18	2.96	18	0.05
19	3 07.27	19	3.12	19	0.05
20	3 17.13	20	3.28	20	0.05
21	3 26.98	21	4.93	21	0.08
22	3 36.84	22	6.57	22	0.11
23	3 46.70	23	8.21	23	0.14
24	3 56.55	24	9.86	24	0.16

Reduce 8 ^h 54 ^m 18 ^s .5 Sidereal Time into Mean Solar Time.				Reduce 8 ^h 52 ^m 50 ^s .96 Mean Solar Time into Sidereal Time.							
				m. s.							
8 hours	..	Equa.	..	1	18.64	8 hours	..	Equa.	..	1	18.85
50 minutes	..	do.	..		08.19	50 minutes	..	do.	..		08.21
4 minutes	..	do.	..		0.66	2 minutes	..	do.	..		00.38
18.5 seconds	..	do.	..		0.05	50.96 seconds	..	do.	..		00.14
Sum	-	1 27.54	Sum	+	1 27.53
Given time		8 ^h 54 18.50	Given time		8 ^h 52 50.96
Mean Time required					8 52 50.96	Sidereal Time required					8 54 18.49

I trust that what has been said by way of reference will be fully understood by Mr. Cooper, and that these tables will be found useful to him and others.

I am, gentlemen,

Your obedient servant,

Portsmouth, Oct. 11, 1824.

GLOSTERIAN.

L. Decas secunda novarum Plantarum Succulentarum ;
*Autore A. H. HAWORTH, Soc. Linn. Lond.—Soc. Horticult.
 Lond.—necnon Soc. Cæsar. Nat. Curios. Moscoviensis Socio,
 &c. &c.*

To the Editors of the Philosophical Magazine and Journal.

Gentlemen,

HEREUNDER I transmit to you a second Decade of New Succulent Plants, all of the Aloëan family—all recently from the Cape of Good Hope—all now flourishing in the Royal Gardens of Kew; and all sent thither from their native wilds by their discoverer Mr. Bowie, our gracious sovereign's most successful collector of succulent plants.

Hoping this communication will find an early admission into your useful miscellany, I remain,

Your obedient servant,

Queen's Elm, Chelsea, Oct. 1824.

A. H. HAWORTH.

P.S. Have the goodness to notice as under, two *errata*, which escaped in my first Decade of succulent plants in your last Number, viz. P. 186, line 10, for *connexis* read *convexis*.

188, in the margin, for *filicaule* read *filicaulis*.

Classis et Ordo. HEXANDRIA MONOGYNIA.

ALÖE.

Perigonium pendulum cylindraceum rectum. Genitalia recta inclusa. Capsula parum costata.

Frutices s. herbæ succulentæ; sed plerumque caulescentes,

lescentes, floribus altè pedunculatis coccineis flavisque : sæpius africanis, paucis americanis, arabicisque, unàque sinensi.

Aloë *Linn., Duval., &c.*

pluridens. A. (many-toothed Tree Aloe) foliis capitatis ensi-

1. formibus recurvantibus viridibus, dentibus marginalibus validis numerosis incurvis.

Obs. A. *arborescenti* proxima, foliorum denticulis duplo numerosioribus; species bona atque speciosa, trunco jam firmo crasso pedali.

BOWIEA.

Perigonium hexapetaloidum, cylindræum, subrectum, obsoletè bilabiatum, laciniis obtusissimis; tribus interioribus ad apicem brevissimè revolutis.

Stamina inæqualia 6, stylusque longè exserti, declinati, rursumque assurgenter incurvi.

Herba succulenta africana Aloëum facie. Capsulam non vidi.

In honorem ejus detectoris, Domini Bowie, peregrinatoris Africani periti, et de plantis succulentis facile optimi, hoc nomen consecravi.

Genus pone Aloë locandum ante Haworthiam.

africana. BOWIEA.

2. *Descriptio.* *Folia* vix subsemipedalia multifaria erectiuscula, supernè parum recurvula, lorato-lineariter acuminata, involuto-latissimè canaliculata, viridia glaucescentiave, lævia substriatula subtus convexa, regione costali rigidiuscula, e parvis incipientibus pallidis verruculis s. maculis lente magis conspicuis: marginibus (foliorum) denticulatis, denticulis distinctis numerosis rectis cartilagineo-albis, vix semilineam longis, subirregulariter positis, et sæpe per lentem subtriangularibus. *Scapus* subpedalis gracilis erectus bracteatus: bracteis *imis* unciam longis subfoliiformibus, basi utrinque dilatatim membranaceis sine floribus: *superioribus* sensim minoribus, cum floribus. *Flores* laxè spicati distincti patentes (nec penduli ut in Aloë) pedunculis perigonio 5-plo brevioribus teretibus basi bracteatis. *Perigonium* e sordidè-luteo viride, tincturâ rufescente, semunciale, laciniis oblongis. *Filamenta* niva, *antheris* obtusis, emarginatis, basi cordatis, polline flavo. *Stylus* albo-lutescens; *stigmatè* inconspicuo.

Obs. *Folia*, *scapus*, et *bracteæ* fere ut in genere *Haworthia* *Duvallii*; sed *Perigonium* ut in *Aloë macra*

Nobis, quæ fortè est genus proprium, ob capsulam baccatam.

HAWORTHIA. *Calyx* petaloideus, rectus, supernè revolutus in duo labia, basi staminifer. *Capsula* in costas valdè prominens. *Fruticuli vix caulescentes, foliis Aloïum, floribus erectis.* Duval. *Plantæ Succulentæ in Horto Alençonio*, A. D. 1809. p. 7. — *Apicra.* Willd. in *Mag. der Gessellschaft. Naturforsch. Freunde* 1811. p. 163, seq.

Obs. Flores brevissimè pedunculati semipatentes.

multifaria. H. (many-leaved Cushion) foliis multifariis minutissimè serrulatis, apicem versus retuso-deltaïdeis pellucetibus, striis viridibus tribus.

Habitat Capite Bonæ Spei. G. H. 4.

Obs. H. retusæ simillima, at minor, foliis lætè viridibus duplo numerosioribus, multi- nec 5-fariis, triploque minoribus; apicem versus ad lucem pellucidè lucidis, lineis tribus viridibus longitudinalibus (sæpeque sesquialterâ) plus minusve completis, et setulâ albâ duplo longiore quàm in *H. retusa* finientibus.

Communicavit Amicus Dom. Hitchin.

β. foliis magis ad apicem lineolatis, mucrone breviori.

Cum α, viget apud Dom. Loddiges; ambæ a Capite Bonæ Spei.

Hæc varietas *H. retusæ* magis approximât, discrepantibus foliis, in directione numero et magnitudine.

asperula. H. (The pale rough Cushion) foliis retuso-deltaïdeis denticulatis, parte retusâ asperis pluri- que lineolatis.

Obs. *H. retusæ* similis, at foliis sordidè viridibus, in parte retusâ granulatim exasperatis, granulis sparsis, lineolisque pallescentibus sub-decem, nec subquinque ut in *H. retusa*.

Foliorum margines carinaque apicis, minutissimè ciliatis denticulatisve, ut in plurimis, ciliis viridibus.

tessellata. H. (The dark-checkered Cushion) foliis retuso-subdeltaïdeis pallidè viridibus, supernè nigro-viridi tessellatis, extus nigro-viridibus, asperis.

Obs. *H. retusæ* valde affinis, sed foliis multifariis.

Folia vix semi-cylindrica, sed magis compressa, recurvula, apice carinata, carinâ marginibusque denticulatis, denticulis albis subrespicientibus; *supra* glabra, pallidè viridia tessellis in parte retusâ, sæpius rhombeis parallelipipedisve, longè saturatoribus; *subtus* aspera præcipuè apicem versus.

parva.

parva. H. (dwarf) foliis cordato-acutis subretusis recurvulis,
6. ciliis minutissimis respicientibus albis; apice subtessel-
latis.

Obs. Folia involuto-concava, extus nigro-viridia, tuberculata aspera; intus pallidiora glabra: in retusâ parte supra, lineolis elevatis subinterruptis tessellantibus saturatioribus.

H. asperiusculæ fortasse proxima (at nunc omnino acaulis) potiusve pone priorem, sed longè minor.

nigricans. H. (The granulated black) asper, foliis nigro-
7. viridibus erecto-expansis pauculis ovato-acuminatis, granulis crebris confluentibus tuberculiformibus nigris.

Obs. Folia basin versus inflexo-concava, apice carinata ut in plurimis, ipsâ basi intus lævia.

Prope *H. scabram* et *recurvam* locanda.

altilinea. H. (The ridge-lined) foliis incurvis ovato-lanceo-
8. latis aristatis minutè denticulatis: supernè utrinque lineâ elevatâ.

Habitat Capite Bonæ Spei. G. H. 4.

Floret Jun.—Augusto, ut in affinis.

Amicus Parmentier, Belgici Leonis Eques, etc. communicavit A.D. 1821.

Descriptio. Inter *H. concavam* et *H. mucronatam* locanda. Folia pallidè viridia supernè carinâ minutissimè denticulatâ finiente in setulâ aristâve membranaceâ fere semunciali: supra plana et apicem versus lineâ costali elevatâ fere in medio.

Obs. Ad lucem folia supernè pellucentia, lineis maculisque viridibus irregulariter subtessellata, ut in affinis. Major quam *H. mucronata*, aristâ longiore quàm *H. concava*: sed optimè distinguitur elevatâ utrinque lineâ.

coarctata. H. (upright dull-spotted) erecta: foliis incurvato-
9. imbricantibus sordidè viridibus, intus glabris, externè maculis parvis sparsis albicantibus.

Obs. Facies quasi inter *H. Reinwardtam* et *Apicram bullulata*, foliis ovato-acuminatis uncialibus extus valde turgidis; apice carinatis, affinium more.

APICRA Willd., Nob.—Aloe Aliorum.

Perigonium petaloideum erectum regulare cylindricum, brevissimè pedunculatum, laciniis 6, brevibus uniformibus apice rotundatis patulis.

Suffrutices parvi succulenti africani (e C. B. S.) omnium rigidissimi, foliolis tecti ut in *Haworthia*, at indura-

induratisissimis acutioribus confertioribus et fere semper spiraliter tortis, apice ipso aculeatum-pungenti.

Genus post prius locandum.

nigra. A. (rough black) foliis multifariis horizontalibus confertissimis cordato-acutis, verrucoso-rugosis atroviridibus.

Obs. A. foliolosæ proxima. *Folia* involuto-concava undique scaberrima margine tuberculato. Suffrutex erectus nunc trientalis solum, et induratisissimus. Inter *Apicram foliolosam* et *asperam* locanda.

LI. On the Weights and Measures. By Mr. THO^s TREDGOLD.

To the Editors of the Philosophical Magazine and Journal.

Gentlemen,

THE time will now soon arrive when an important change is to take place in our measures of capacity, and I have been surprised to see so little notice taken of the subject. I have endeavoured as far as possible to recommend by practice, a new system of measuring capacity to engineers, because it appeared to me better adapted for every purpose which they have occasion to consider. It consists in adopting the cubic foot instead of the gallon as a measure in hydraulic and other calculations. A little perseverance soon renders the cubic foot as familiar as the gallon, and it saves time in every kind of calculation, and removes uncertainty. In Smeaton's works you will sometimes find the quantity of water that will serve a water-wheel expressed in wine-gallons, and in other instances his calculations are made in ale-gallons; and where the kind of gallon is not distinctly stated, it renders it difficult to ascertain what measure has been employed.

In changing the gallon there seems to have been a natural relation of measures of capacity overlooked, which it would have been some advantage to have attended to: I allude to the relation between a cube and its inscribed cylinder. The gallon might have been made one-fourth of the capacity of a cylinder one foot long and one foot in diameter. The cylinder is the best form for measures of this kind, and it would be very desirable to have a cylindric measure which could be regarded as an unit in all calculations where the areas of circles and contents of spheres are concerned, because our linear measures would apply to ascertain such quantities without reducing them into cubical inches. And it seems more natural to found a system of measures on the nature of the things to
be

be measured, than on any relation to a standard in nature. The French have taken their standard from the globe, and yet have omitted to provide a measure for one; they have affected to borrow from nature, and have overlooked the most obvious of natural distinctions.

I am glad that so much of our old measures and weights are to be preserved, for I have not yet obtained enough of knowledge to enable me to do without referring to my predecessors, and I am extremely unwilling to encounter any additional difficulty in holding communication with them; it makes one think seriously about the advantages promised by the change to the decimal system. What foundation has this decimal system in the nature of things?—will it continue for ever to be the best possible system of notation? or, is it itself imperfect and likely to be changed as soon as a better shall appear? If the latter be the case, what is to be done with a system of weights and measures formed on the decimal scale? For my own part, I am one of those who think our system of weights and measures to be founded on more rational principles than our notations. If the notation had been formed on principle, surely 10 would never have been fixed upon for the basis of the system; it has only two factors, and one of these is a prime, which is not so frequently a factor as the prime below it; and which renders it often more convenient to work by vulgar fractions than by decimals. That is, the prime 3 occurs more frequently in calculations than the prime 5; and whenever the prime 3 is a factor of division, the decimal notation is incapable of expressing the quotient. The decimal system owes all its advantages to the happy thought of arranging numbers according to their powers; but this arrangement is not peculiar to it; in algebra we adopt a modification of the same principle, but there it is not limited to 10 digits, for we are able to arrange powers or any multiples of powers; and it will be of incalculable advantage to obtain an equally general arrangement for common numbers. Our present system is very unwieldy when there is occasion to express large numbers, perhaps quite as much so as those abandoned in favour of the Arabic notation were for ordinary numbers; and I think no one will venture to say that it is impossible to invent a more perfect notation than the one now in use. Apparent simplicity is not a test of the merit of any invention, unless that simplicity be accompanied by fitness for the objects it is to accomplish; and it is not much in favour of the decimal scale to remark, that there are 4 out of the 9 digits of which the reciprocals cannot be expressed in finite terms; viz. $\frac{1}{3}$, $\frac{1}{6}$, $\frac{1}{7}$, and $\frac{1}{9}$; and that to express $\frac{1}{4}$ we must employ

two figures, and to express $\frac{1}{3}$ three figures are necessary;— and are ratios of such frequent occurrence of no importance? They would no doubt occur less frequently were money, time, weights, and measures all decimally divided; but what does this concession involve? Nothing less than an entire change of language in all cases where any thing relating to time, weight, prices, or measures is the subject; and with a less degree of change the inconvenience of a decimal division will be much greater than the ones now in use.

The advocates for decimal division do not appear, as far as I have seen, to have studied the nature and advantages of the old divisions. For example, in the division of time all the prime digits are factors; the principal divisions are by 60th parts, and 60 is composed of $2^2 \times 3 \times 5$; the only prime digit not included, being 7; and we only want a more convenient notation to render it far superior to any decimal division; superior both in the facility of expressing minute parts; and in expressing large numbers. The number 10 is too small for such an object; the cube of 10 is not equivalent to the square of 60, besides the defect of not enabling us to express $\frac{1}{3}$, $\frac{1}{6}$, $\frac{1}{9}$, &c. I have had several schemes for improving the notation; and though I have not hit upon one of sufficient convenience, the success has been such as to render it pretty certain that the thing is not impossible.

I am, gentlemen,

Your most obedient servant,

THOMAS TREDGOLD.

LII. *Notices respecting New Books.*

Recently published.

A PRACTICAL System of Algebra, designed for the Use of Schools and private Students. By P. Nicholson, and J. Rowbotham.

Preparing for Publication.

An Explanatory Dictionary of the Apparatus and Instruments employed in the various Operations of Philosophical and Experimental Chemistry. In 8vo., with seventeen Quarto Copper-plates. By a Practical Chemist.

The Farmer's, Shepherd's, and Mariner's Pocket Dictionary, containing rules for judging of the weather, &c. alphabetically arranged.

ANALYSIS OF PERIODICAL WORKS ON NATURAL HISTORY.

Curtis's British Entomology.

No. 9—10. contains the following subjects :

Pl. 35. *Cryptocephalus bipustulatus*. A species well known on the continent, but never before ascertained to be British.—Pl. 36. *Lithosia muscerda*. Never before published as a native of Britain.—37. *Raphidia Ophiopsis*. The female of this curious insect is figured; the male differs in nothing but the termination of the abdomen; the ovipositor of the female is very singular in its structure.—Pl. 38. *Hedychrum ardens*. A splendid species of this beautiful genus new to Britain.—Pl. 39. *Thymalus limbatus*. This valuable insect, so long unnoticed as British, and apparently confined to the New Forest, has this year been taken in Kent.—Pl. 40. *Sesia Bombyliformis*. A figure of this charming insect is here given, as well as the larva (we believe for the first time), and the pretty plant upon which it feeds.—Pl. 41. *Cimber 10-maculata*. A magnificent species, a unique specimen of which is preserved in the British Museum: this also has never before been figured.—Pl. 42. *Pachygaster Leachii*. A new species, not known to Meigen; named after our esteemed countryman Dr. Leach.

LIII. *Proceedings of Learned Societies.*

ROYAL ACADEMY OF SCIENCES OF PARIS.

April 19. — **M.** DU PETIT-THOUARS finished the reading of his Report on M. Romain's Memoir relative to the Anatomy of Plants.—M. Girard, in the name of a Commission, read a Report on M. Burdin's Hydraulic Turbines.—M. Bosc made a verbal Report on a pamphlet by M. le Comte Dejean relative to the method of preserving seeds.—M. Arago communicated various consequences which he had deduced from M. Duperrey's observations on the diurnal variation of the magnetic needle; one of which is, that there is no diurnal variation on the magnetic equator.—M. Dujac commenced reading his Memoir "*sur la Caloricité.*"—M. Bailly read a Memoir, entitled "Researches on the Anatomy of the Brain of the Mole."

April 26.—M. Chevalier announced the formation of ammonia during the oxidation of iron, by the contact of water and air.—M. Gaillardot transmitted a Memoir on the Fossil Bones of the environs of Lunéville; M. Rolando, of Turin, his Anatomical Researches on the Spinal Marrow; M. Damoiseau, a second work on the Periodical Comet of 1819; and Don P. L. D. Yamaha, of Madrid, an extract from his Memoir on Medicine.—M. Cauchy, in the name of a Commission, made a Report on M. Dubuat's Memoir relative to the Calculus of variations.—M. Moreau de Jonnés read a notice, entitled, "Itinerary of the contagious malady known un-

der the name of Cholera-Morbus."—M. Bory de St. Vincent communicated his observations on the spermatic animalcula, for which he proposed the generic name of *Zoospermes*.—M. de Lassis read a Memoir, entitled "The Doctrine of Epidemic Maladies."

May 3.—M. Julia Fontenelle transmitted his manuscript translations of several Memoirs on the Yellow Fever, by the Physicians of Barcelona.—M. G. Saint Hilaire read an additional Memoir on the Nutrition of the Marsupialia.—M. Fresnel presented to the Academy a Pharos-light with a fixed burner of the third kind, invented by him.—M. Bailly read a Memoir, entitled "Description of the filaments with which the *Lophius piscatorius* seizes fish:" and M. Geoffroy made some remarks on the subject.

May 10.—The Minister of Marine communicated in manuscript M. Bagay's new logarithmic tables, and requested the Academy to examine them.—The Marshal Duke of Ragusa read a Report on the experiments made at Brest on the new kind of Artillery proposed by M. Paixhans.—M. Permon, of Lyons, transmitted a Memoir on the cause of the mephitic effects of marshes.—M. Percy communicated some observations on a young person named *Trezel*, deaf and dumb from the birth, whom Dr. Deleau had enabled to hear and to speak.

May 10.—M. Cuvier made a verbal Report on several Memoirs formerly presented in manuscript, but since printed by their respective authors. These were the Memoirs by M. Flourens, *On the Functions of the different Parts of the Nervous System*; those of M. Desmoulins, *On the Anatomical Relations of that System*; and lastly, a Memoir by M. Bailly, entitled, *A Treatise on the Comparative Anatomy and Physiology of the Nervous System, in the four Classes of Vertebrated Animals*.—M. Audouard read a Supplement to his Considerations on the Origin and Cause of the Yellow Fever.

May 17.—M. Vicat communicated a Memoir on a periodic thermometrical movement observed in the arches of the Bridge of Souillac: M. Bonnemaïson, an apothecary at Quimper, a manuscript work on the *Hydrophytes loculées* which grow in France; and M. le Baron Blin a note on the precise determination of the grave resonances of two given sounds.—M. Vauquelin, in the name of a Commission, read a Report on M. Payen's analysis of Tupinamba Root.—M. G. St. Hilaire communicated a Report on the Memoir of M. Bailly concerning the *Lophius*. He commences by showing that Aristotle was acquainted with the habits of this animal. In the works of that prince of naturalists is a passage to the following effect: "There

is a species of frog, which is called *the fisher*. It derives this name from the wonderful industry which it displays in procuring its nourishment; for in front of its eyes it has certain appendages, which it extends like hairs, and which, dilated at the extremity, form a kind of double bait. After having stirred up the mud or the sand, it conceals itself, and elevates these appendages; the little fish coming to seize them, it draws them into its mouth. Plutarch says; "The Lophius fishes with the line, for it throws out from its neck a filament, which it extends to a distance, in the manner of a line, letting it out and drawing it in at will. This being done, when it perceives some small fish about it, it allows them to nibble the extremity of this filament, being itself concealed beneath the sand, or in the mud, when it gradually retracts that member until the fish are near enough to be swallowed by a quick movement."

These *filets pêcheurs*, as they are called by the author, have formed the subject of his researches; he determines their nature, and describes their general support. M. Bailly says, that the third filament is articulated directly with the occipital integument:—the Reporter thinks otherwise, and details his objections. The description of the muscles which serve for the various motions of the filaments is very satisfactory, and shows that the ancients were not deceived with regard to the purposes for which these appendages are destined.

So voracious an animal as the Lophius, however, cannot obtain, *by fishing* alone, sufficient to supply its wants. M. Geoffroy describes the other habits of this singular fish, and concludes by recommending the insertion of M. Bailly's Memoir in the *Recueil des Savans étrangers*.

ACADEMY OF SCIENCES OF COPENHAGEN.

Questions proposed for 1825.

Class of Mathematics.—To deduce new tables of the sun from a collection of the best observations, and by the assistance of analysis, to compare these tables as well with the observations of Bradley as with the best of those which have been made since, principally with the observations that have been made with an instrument not exposed to the heat of the sun.

Class of Physics.—Careful observations are required, having for its object the discovery of the connections that exist between the promptitude of the germination, the quality of the fruit and seed, and the development of the other parts of plants. These observations are to be made not only on the acotyledons,

acotyledons, the monocotyledons, and the dicotyledons, but also upon the principal orders of which the three great divisions are composed.

Class of Philosophy.—What is the true notion of psychology, and what is the relation of this science to those which are connected with it;—should the distinction be admitted, which some of the learned have wished to establish between empiric psychology and rational psychology.

The memoirs, written in French, Latin, or German, will be received until the 1st of January 1825.

ROYAL ACADEMY OF BRUSSELS.

Prizes proposed for 1825.

1st. What has been the state of the maritime coast between Boulogne and Antwerp, from the Conquest of Cæsar to the present time? To indicate the great inundations of the sea which this coast has experienced during the foregoing period, and to ascertain what portions the sea has engulfed which have not been regained.

2d. What are the kinds and degrees of fermentation that the different species of animal excretion undergo.

3d. The great discoveries made during a certain number of years having considerably augmented the domain of the botanist, the Academy requires a confirmation or refutation, by a critical examination, according to the laws established by Linnæus, of the different genera and species introduced in botany since the death of that great man, and a determination, by the same laws, of the propriety of the denominations that have been given to these genera and species. The titles and editions of the works referred to, to be cited with exactness.

4th. To determine the changes that may be occasioned by the felling of considerable forests upon the adjacent countries and commons, with respect to the salubrity and temperature of the air, to the duration and violence of the prevailing winds, and generally to all meteorological phænomena.

The prize for each of these questions to be a gold medal, of the weight of thirty ducats. The memoirs, written in French, Dutch, Latin, or Flemish, to be addressed (post free) to M. Dewez, before the 1st of February 1825. The Academy will also award, at the same time, the other prizes.

LIV. *Intelligence and Miscellaneous Articles.*

THE COMET.

MR. Encke's investigations on the orbit of the comet which is now visible, prove that it moves in a hyperbola.—Mr. E. has found the following elements:

Time of passage through the perihelion	Sept. 29, 02259
Longitude of the perihelion	4° 25' 57".2
Longitude of the ascending node	279 15 31 .6
Inclination of the orbit	54 43 7 .8
Eccentricity.....	1.006046
Logarithm <i>q</i>	0.0217381

THE DISCOVERY SHIPS.

The following is an extract of a letter from the agent to Lloyd's at Hull, dated the 7th of October:

“The *Mary-Frances*, Capt. Wilkinson, has arrived from Davis Straits, and reports that she saw the Discovery Ships beset in the Middle Ice on the 17th of July, in lat. 70. long. 5. Capt. Wilkinson entered the ice on the following day in lat. 66. long. 20. and penetrated to the West Land on the 26th, where he remained until the 9th of September, when he bore away for England, having taken 15 whales. He was nearly as high as Lancaster Sound, and states that the prospect for the Discovery Ships was very favourable, as the weather was fine, and the coast unusually free from ice. As he never met them after he got through the barrier of ice, there can be no doubt of their having had an equally favourable passage. The *Mary-Frances* and the *William-and-Ann* were the only ships which got through the barrier in the month of July; the remainder of the fishing vessels having attempted the passage in a higher latitude, did not succeed until August. There had been no losses; but one of the ships (the *Jane*, of this port) had sustained considerable damage.”

ANTIQUITIES.

Part of a Roman villa was opened on Tuesday the 21st of September, at Wigginton, in a field belonging to George Cobb, Esq. of Broughton Castle, when a room 20 feet long by 14 feet wide was completely uncovered, and a great portion of the tessellated pavement was found nearly perfect. There are other remains scattered over a considerable extent of ground, which have not yet been examined.—*Oxford Journal*.

MUNGO PARK.—AFRICA.

We have been favoured by a gentleman interested in African discovery, and who has travelled a considerable way into the interior

interior of the southern parts of northern Africa, with some notes regarding the death of our lamented countryman, Mr. Park. The narrative is drawn from a negro, a native of Yaourie, adjoining the spot where Park perished, and who witnessed what he relates. Considering every circumstance, the document is clear and satisfactory, plain and unadorned, without anything that leads to a suspicion of its accuracy, or the intention of the negro to deceive, and in its most material features it is borne out by accounts obtained through other channels. The notes from which the following summary is drawn up, were obtained in 1822:

Duncanno, a negro, was born at Birnie Yaourie. He was in the Pass about to be mentioned, to sell *collas*, when he was seized by the Foulahs, carried off as a slave, and afterwards taken to the Gold Coast, where he was shipped on board a Portuguese vessel, and carried to Bahia, where he remained three years. He was employed in a Portuguese slave ship as a seaman, and returned to Africa in her, during Governor Maxwell's residence on the coast. Duncanno states, that he was in his native country, Birnie Yaourie, sixteen years ago (1806), when Mr. Park arrived there in a canoe with two masts. No person landed. The canoe continued her course down the river with the travellers in her. The king of Yaourie, aware of their danger, sent off eight canoes after them, to warn them of it, and in one of the canoes was sent a red cow, intended as a present to the white men. Mr. Park did not communicate with them, but continued sailing onwards. The canoes followed, and at last Mr. Park, probably dreading hostile intentions, fired upon them, but fortunately did not kill any one. The canoes returned; but the king, anxious for the safety of the travellers, again sent people to proceed after them, requesting them to stop, and he would send persons to show them the safe and proper passage in the channel of the river. The messengers could not, however, overtake them. Park continued his voyage till the vessel got amongst the rocks off Boussa, and was in consequence "broke."

Birnie Yaourie is in Houssa, but Boussa is not. The latter is in the country called Burgoo. Birnie Yaourie is by land distant one day's journey from Boussa, but by water one day and a half. Duncanno described the place or pass, where the canoe was broken, to be like the cataracts in our mountains; The water ran with great force. The canoe was carried rapidly along, and before they could see their imminent danger, it struck with violence on some rocks and was dashed to pieces. The people of Boussa stood upon the rocks projecting into the river, desirous, if possible, to afford the white men assistance; but

but the catastrophe was so sudden, and the violence of the stream so great, that they could not reach them. The break of the river on the rocks is described as dreadful. The whirlwinds formed were appalling, and the agitation of the waters was so great as almost to raise the canoe on its end, and precipitate it, stem forwards, into the gulfs below it. At the moment the vessel struck, Mr. Park held something in his hand, which he threw into the water, just as the vessel appeared to be going to pieces. The "water was too bad"—so agitated that he could not swim,—and he was seen to sink in it. There were "plenty" of other white men in the canoe, all of whom were drowned. The river there is as broad as from Le Fevre Point to Tagrin Point, Sierra Leone, or above four miles. There was a black man, a slave, who was saved from the canoe. This black man spoke the Foulah language, and was a slave to a Foulah-man. When Duncanno left Yaourie, this man was still in Boussa, but he knows nothing more of him.

Duncanno asserted positively that no person from Park's vessel landed at Birnie Yaourie, that the Black was the only individual saved, and that that man only was left at Boussa. The people of Boussa went in canoes to this "bad place" in the river, where Park's vessel was broken, and where he was drowned, and some expert divers dived into the stream and picked up twelve pistols and two long musquets. "Plenty of people" went from Birnie Yaourie to Boussa to see the wreck after the king of Boussa had sent to the king of Yaourie to inform him of the disaster. Park informed the black man who was in the boat that in a week or two he should carry him with the canoe into a "great ocean," where the water was salt!

Thus far the simple narrative. It bears the stamp of truth upon it, and it is impossible to reflect upon the catastrophe without feelings of the deepest sorrow and regret at the loss of the enterprising traveller when he was so near completing his labour, and reaping the reward of all his toils. Various accounts, obtained through our present channel of information, agree in stating, that from below Boussa to Benin the river is open and deep, and broad and navigable.—*Glasgow Courier*.

NEW SOUTH WALES.

[At page 459 of our last volume, we gave, from *The Morning Chronicle*, an interesting article on this rising country; the further progress of discovery and of manufactures in which we now give some particulars of from the same source. The writer appears to be a resident in the country.]

A gentleman, who was in the interior with Mr. Oxley, told me that he once met with a party of interior natives, all of whom,

whom, on seeing him, fell instantly upon their faces, forming a circle with their heads outwards, apparently in the greatest trepidation and terror. Another party he fell in with appeared struck with great wonder and surprise at his strange colour and garb, but were nothing like so intimidated, as they walked with him some distance. The natives found lately by Mr. Oxley, at Moreton Bay, are far superior in every respect to their brethren near Sydney. They build huts of wattle, covered with tea-tree bark, capable of containing ten people, which they clean out regularly twice a day, and are governed by chiefs who have great authority over them, and perform none of the duties of fishing and hunting, except as a pastime, the others supplying them regularly with whatever they stand in need of. The chiefs' wives are equally exempted from labour. Fish, fern root, and kangaroo, are their principal sustenance. Like all the other nations of Australia, they are surprisingly honest, but most persevering beggars, and whatever was given them no one ever saw afterwards. Women were often seen with a child at one breast, and a young puppy at the other. The women perform all the labour and drudgery, the men only fishing and hunting. In hospitality and kindness, the famed natives of Lew Chew do not exceed them. Two shipwrecked convicts, lived among them many months, with a humanity and cheerful hospitality, which in vain you may look for in civilized communities; they would not even allow them to procure or cook their own provisions, and always supplied them most liberally, even when they often went without themselves. The most disagreeable ceremony they had to comply with, was a daily burnishing with beeswax and charcoal, to which they reluctantly submitted, to please their kind hosts, who appeared to have a great horror of the hateful whiteness of their skins. One of the convicts once put on the fire a tin pot of water, which was quickly surrounded by the wondering natives; but on its boiling up they gave a loud yell, and ran screaming in all directions, nor would they come near until it was thrown away, when they covered it carefully with sand, and could never afterwards be induced to consent to the magic pot being again placed on the fire.

Our manufactures are yet in their infancy, and consist only of articles of most pressing necessity. Salt is made in different parts from sea water, partly by spontaneous evaporation, and partly by boiling. Mr. John Blaxland makes large quantities this way on the creek, about three miles from Paramatta. He has a succession of shallow basins, where evaporation goes on, being drawn off from one to the other until it is sufficiently concentrated

concentrated to require little boiling to crystallize it. Tanning is carried on every where extensively, both upper and sole leather being made, of excellent quality. Nothing can excel the bark of the wattle for tanning, and the kangaroo skin produces uppers equal to the best calf. A great many of the large farmers manufacture all their own leather; indeed numbers not only do so, but make all their shoes, and manufacture all the coarse cloth for their servants' clothes, and perform all their own smith-work upon their farm, being supplied by Government with convict mechanics, for which they pay to them 3s. 6d. a week, besides the usual wages to the convict. A considerable quantity of coarse woollen cloth is made for sale at Mr. S. Lord's manufactory, near Botany Bay, which is sold dearer, but wears much better, than English cloth of the same fineness. Several others also manufacture cloth on a small scale for sale, while all who have wool to spare may have it made into cloth at the Government Female Factory, Parramatta, by paying the expense of manufacturing it into wool. Saddlery, tinware, soap and candles are also made in great abundance, and there is likewise a small foundry for casting iron. Hat-making has long been a thriving trade; both coarse and fine ones are manufactured in Sydney, the latter being beavered with the fur of the flying squirrel, which is of a silky softness and beautiful slate colour; the skins cost the hatters 1s. 3d. a-piece. Two potteries have been for some years in constant employment. Our clay is admirably adapted for these purposes, and most of our common heavy ware is supplied from these two sources. Milk bowls, large covered butter vessels capable of holding 40lbs., also some of a similar construction for salting meat, wine and butter coolers, common jugs, bowls, cups and saucers, tea-pots, spruce-beer bottles, &c. are all made here. The glazing, however, is nothing like so good as the Staffordshire, for want of proper means, as both the men who conduct them were brought up in the best manufactories in that country. Ploughs, carts, waggons, harrows, and all farming utensils are made and sold cheaper here than they can be imported from England.

THE LOGAN ROCK.

Our readers may remember that a Lieutenant Goldsmith of the Navy distinguished himself rather unenviably last spring, by the gallant exploit of effecting the overthrow of the curious Logan or Rocking-stone in Cornwall. He is now endeavouring, it appears, to set it up again; and in a particularly absurd paragraph, in an Exeter paper, we find him complimented

Vol. 64. No. 318. Oct. 1824. R r after

after this sort. "It is with a great degree of pleasure that we are enabled to inform the curious and the lovers of antiquity, that an attempt is at last being made to restore this celebrated stone to its former pinnacle of wonder and surprise. We are aware of there being a diversity of opinion respecting it, but we hope the majority of our readers will be gratified to hear that Lieut. Goldsmith, with a zeal truly characteristic of a British tar in redeeming past errors, and *ever anxious to please*, commenced his operations on Tuesday last, with about thirty able seamen, by landing the requisite apparatus from boats beneath the cliff." As this officer is pronounced "ever anxious to please," we must presume that he threw down the rocking-stone to please himself (for we are persuaded that so wanton a piece of mischief pleased no one else), and that he restores it to its "former pinnacle of wonder and surprise," as the Exeter journalist sublimely expresses it, to please the rest of the world. Whether when it regains its "pinnacle of wonder and surprise" it will resume its wonderful and surprising custom of rocking, would seem, however, rather problematical; and we conceive that Lieut. Goldsmith cannot set himself right with the lovers of rocking-stones till he sets the rock once more rocking.—*Morning Chron.*

In a very excellent and unpretending little work, entitled "A Guide to the Mount's Bay, and the Land's End," published by W. Phillips, we find the following account of this celebrated wonder, now, we fear, no more:—"The celebrated Logan-stone is an immense block of granite, weighing above 60 tons. The surface in contact with the under rock is of very small extent, and the whole mass is so nicely balanced, that notwithstanding its magnitude, the strength of a single man applied to its under edge, is sufficient to change its centre of gravity, and though at first in a degree scarcely perceptible, yet the repetition of such impulses, at each return of the stone, produces at length a very sensible oscillation. As soon as the astonishment which this phænomenon excites has, in some measure, subsided, the stranger anxiously inquires how, and whence the stone originated. Was it elevated by human means, or was it produced by the agency of natural causes? Those who are in the habit of viewing mountain masses with geological eyes will readily discover that the only chisel ever employed has been the tooth of time—the only artists engaged, the elements. Granite usually disintegrates into rhomboidal and tabular masses, which, by the further operation of air and moisture, gradually lose their solid angles, and approach the spheroidal form. De Luc observed in the Giant Mountains of

of Silesia, spheroids of this description, so piled upon each other as to resemble Dutch cheeses; and appearances no less illustrative of the phenomenon may be seen from the signal station to which we have just alluded. The fact of the upper part of the cliff being more exposed to atmospheric agency, than the parts beneath, will sufficiently explain why these rounded masses so frequently rest on blocks which still preserve the tabular form; and since such spheroidal blocks must obviously rest in that position in which their lesser axes are perpendicular to the horizon, it is equally evident, that whenever an adequate force is applied, they must vibrate on their point of support."

EARTHQUAKES.

At San Pietro in Bagno, in the Grand Duchy of Tuscany, several earthquakes of minor importance have been lately felt. In the morning between the 12th and 13th of August, not less than twenty shocks were distinctly perceived. Three, tolerably strong, occurred about seven o'clock, which made the church bells ring. At Salva-piana, which was the spot most affected, a wall was thrown down, but happily without injuring any person. During the following day and night the earthquakes continued, but with trifling effect. A haziness of the atmosphere and a particular kind of obscurity about the sun were the phenomena remarked immediately previous to these convulsions of Nature.

METEOR AND EARTHQUAKE.

A traveller, who happened during the nights of the 11th and 12th of August to be upon the Alps, reports that he saw a globe of fire which lighted the atmosphere for three minutes; and about the same time the shocks of an earthquake were felt in several parts of Italy.

FOSSILS.

The labourers engaged in excavating the bed of Wallasey Pool, for the purpose of making a wet dock, have lately discovered several fine stags' horns, in the most perfect state of preservation. It is probable that what is now termed Wallasey Pool was anciently part of a wood or forest, as in the neighbourhood the remains of large trees are frequently found at different depths below the surface, of a very dark colour; some as black as coal, and so hard that the farmers use them as gate-posts. The horns were found nearly thirty feet below the bed of the pool. The workmen, it is said, have also discovered evident traces of an ancient road having once existed there at the same depth.—*Liverpool Courier.*

FOSSIL ELEPHANT.

A fossil elephant has been discovered on the east side of Lyons, in a garden situated on the hill which separates the Rhine and the Saone. The bones were found in what the men supposed was virgin earth, that had never been turned up by either spade or pick-axe. M. Bredin, the Director of the Royal Veterinary School, repaired to the spot, and recognised in the huge bones discovered by the workmen, the bones of an elephant. The humerus was twelve feet and a half long, and nine inches broad at its upper extremity; the tibia was two feet and a half; and two fragments of the scapulum were together two feet in length. There was the head of a femur, and several other pieces of bones, so that M. Bredin had no difficulty in coming to a decision. Among the elephant's bones the bones of an ox were also discovered.—*French Journal.*

EGYPTIAN ANTIQUITIES.

M. Champollion jun., having proceeded to Turin under the auspices of His Majesty, to study the collection of Egyptian antiquities brought together by M. Drouette, and forming at present the Royal Egyptian Museum of the King of Piedmont, has already made known some of the principal monuments of this museum. We extract the following communications from his letters:

“By the kind permission of His Excellency Count Chale, Minister of the Interior, I have gained admission to the Royal Egyptian Museum. I had previously admired in the Palace of the University a fine statue of Sesostris, in rose granite, eight feet high; the upper part of a statue of the wife of that king, the queen Ari; and another statue with a lion's head, similar to two statues in the Museum of Paris, and bearing an inscription of the reign of Amenophis-II.

“It was on the 9th of June that I visited for the first time the Egyptian Museum: nothing is comparable to this immense collection. I found the court crowded with colossal figures in rose granite and green basalt. The interior is also peopled with colossal monuments. A first examination discovered to me a group of eight feet in height: it turned out to be Amon-Ra, seated, having beside him King Horus, son of Amenophis II. of the eighteenth dynasty—an admirable work; I had seen nothing equal to this. 2dly, A colossal statue of King Misptra-Thouthmosis, in the same state of preservation as when it issued from the workshop. 3dly, A *Monolith* six feet high; it represents Ramses the Great (Sesostris), seated upon a throne between Amon-Ra and Neith, of rose granite, and is a perfect work. 4thly, A colossal figure

figure of King Mœris, green basalt, of exquisite workmanship. 5thly. A statue, erect, of Amenophis II. 6thly, A statue of the god Phta, executed in the time of the last-mentioned king. 7thly. A group of freestone, representing King Amenoftep, of the nineteenth dynasty, and his wife Queen Atari. 8thly, A statue, larger than life, of Ramses the Great (Sesostris), in green basalt, finished like a cameo; upon the steps of the throne are sculptured, in full relief, his son and wife.

“The number of funeral statues in basalt, red and white freestone, white calcareous stone, and gray granite, is very considerable: amongst them is one of a man crouching, whose tunic bears an inscription in the Egyptian vulgar tongue, of four lines. The *steles* of four, five, and six feet in height, exceed the number of a hundred; there is an altar covered with hieroglyphic inscriptions, with a great number of other objects of antiquity. This comprises only one part of the collection, and there remain two or three hundred packages to be opened. The number of manuscripts is one hundred and seventy-one, of which forty-seven are already unrolled. Among these I have discovered about ten contracts in the Demotic writing; a Greek papyrus, and a law-suit between two inhabitants of Thebes relative to the ownership of a house; the pretensions of the parties pleading and the means of the advocates are analysed, and the laws favourable to their respective pretensions textually cited.

“At the end is the actual judgement, which was delivered in the fifty-fourth year of Ptolemy Euergetes II. A bilingual inscription in Egyptian and Greek, and a decree in honour of a prefect of the township of Thebes, and rendered under the reign of Cleopatra and her son Cesarion, whose I had already proved the actual reign by the perusal of a scroll sculptured upon the temple of Dendera. But that which is most interesting is, that among the papyrus of the collection, is a Phœnician manuscript; unfortunately there are but fragments of it, but perhaps others may be found amongst those not yet unrolled.”—*French Journal*.

Meteorological Observations at Great Yarmouth, by
C. G. HARLEY, Esq.

1824.	Days.					Winds.					Thermom.			Rain:
	Dry.	Wet.	E.	SE.	S.	SW.	W.	NW.	N.	NE.	Low.	High.	Med.	In.
May	14	17	7	4	3	1	—	3	9	4	46	72	55	2½
June	16	14	1	9	3	3	1	—	3	10	55	69	60	2½
July	22	9	—	2	3	8	6	2	2	8	60	79	69	2½
August	15	16	2	4	3	7	4	2	5	4	60	72	66	2½

Calendar of Flora, Fauna, and Pomona, at Hartfield in Sussex, continued from September 19 to October 20.

Sept. 19.—*Crocus autumnalis* in flower in the garden. The weather is extremely unfavourable for the production of flowers, and the autumnal Flora is very backward and defective. The China Asters, African Marigolds, and other plants of this sort have very generally failed, by being thrown so late in the season as to be injured by the rains before they could flower. Holyhocks, the Prince's Feather, and other Amaranths abound only in a few places: in others all the plants have done badly.

Sept. 29. — Michaelmas Day. The Michaelmas Daisy, *Aster Tradescantii*, the *Aster tardiflorus*, and some others of this genus are in full blow. *Agaricus integer*, *A. aurantius*, *Boletus edulis*, *Boletus bovinus*, and some hitherto undescribed fungi are growing.

Oct. 2.—*Agaricus muscarius* in abundance, both in the grove and in the orchard. The species, however, has not been luxuriant this year in general. Swallows have become less numerous, several large migrations having taken place. Small-birds congregate in flocks. Wasps seem to be wanting altogether this season.

Oct. 12.—Weather damp and showery. The last white currants gathered. Today there fell almost a deluge of rain, which flooded the meadows, and gave the marshes of the Medway the appearance of a lake.

Oct. 14.—Martins, *hirundines urbicae*, still seen. The weather cleared and became colder.

Oct. 18.—*Agaricus floccosus* abundant under an apple-tree in the orchard. The popular prejudice of fine weather about St. Luke's Day has been verified again this year.

Oct. 20.—Some few swallows seen today flying about a paper kite which was elevated very high in the air.

This season has been one of the worst for apples ever remembered. Pears are rather more plentiful. A few peaches still remain.

T. FORSTER.

LIST OF NEW PATENTS.

To Francis Henry William Needham, of David-street, Middlesex, esq., for his improved method of casting steel.—Dated 7th October 1824.—6 months allowed to enrol specification.

To Walter Foreman, esq. of Bath, Somersetshire, commander in the Royal Navy, for certain improvements in the construction of steam-engines.—7th October.—6 months.

To Fredrick Benecke, of Deptford, Kent, verdigris manufacturer, and Daniel Towers Shears and James Henry Shears, of Fleet-market, London, coppersmiths, who, in consequence of a communication from a certain foreigner, are in possession of certain improvements in the making, preparing, or producing of spelter or zinc.—7th October.—6 months.

To

To Pierre Alegre, of Kerez de la Frontera, Spain, engineer, now residing at Colet-place, Commercial Road, Middlesex, for his improved and economical method of generating steam applicable to steam-engines and other useful purposes.—7th October.—2 months.

To Humphry Jeffreys, of Park-street, Bristol, merchant, for his improved flue or chimney for furnaces and other purposes.—7th October.—2 months.

To Robert Dickenson, of Park-street, Southwark, Surry, esq. for his improvement or improvements in the manufacture and construction of metal casks or barrels, for the conveyance of goods and products by sea or otherwise.—7th October.—6 months.

To Francis Richman, of Great Pulteney-street, Golden-square, Middlesex, carpenter, for certain improvements in the construction of fire-escapes, part of which said improvements are likewise applicable to other purposes.—7th October.—6 months.

To Stephen Wilson, of Streatham, Surry, esq., who, in consequence of communications made to him by foreigners residing abroad, is in possession of certain improvements in machinery for making velvets, and other cut works.—7th October.—4 months.

To John Ham, of West Coker, Somersetshire, vinegar-maker, for his improved process for manufacturing vinegar.—7th October.—4 months.

To Matthew Bush, of West Ham, Essex, calico-printer, for certain improvements in machinery or apparatus for printing calicoes, and other fabrics.—7th October.—6 months.

To John Shaw, of Milltown, in the parish of Glossop, Derbyshire, farmer, for his transverse spring slides for trumpets, trombones, French-horns, bugles, and every other musical instrument of the like nature.—7th October.—2 months.

To John Thomas Hodgson, of William-street, Lambeth, Surry, veterinarian, for certain improvements in the construction and manufacture of shoes or substances for shoes for horses and other cattle, and method of applying the same to the feet.—7th October.—6 months.

To Philip Chell, of Earle's-court, Kensington, Middlesex, esq. for his improvements in machinery for drawing, roving, and spinning of flax, wool, waste silk, or other fibrous substances.—14th October.—6 months.

To John George Bodnier, of No. 50, Oxford-street, Charlton-row, in the parish of Manchester, Lancashire, civil engineer, for certain improvements in the machinery for cleaning, carding, drawing, roving and spinning of cotton and wool.—14th October.—6 months.

To James Gunn, of Hart-street, Grosvenor-square, Middlesex, coach-maker, for certain improvements in wheeled carriages.—14th October.—6 months.

To William Philip Weise, of Tooley-street, Southwark, Surry, manufacturer, for certain improvements in the preparing and making water-proof cloth, and other materials for the manufacturing of hats, bonnets, caps, and wearing apparel, and in manufacturing the same therefrom.—14th October.—6 months.

To Henry Marriott, of Fleet-street, London, ironmonger, for an improvement on water-closets.—14th October.—2 months.

To James Fetlow, of Manchester, Lancashire, weaver, for certain improvements in power looms for weaving various articles.—14th October.—6 months.

To Henry Maudslay, and Joshua Field, both of Lambeth, Surry, engineers, for their method and apparatus for continually changing the water used in boilers for generating steam, particularly applicable to the boilers of steam-vessels making long voyages, by preventing the deposition of salt or other substances contained in the water, at the same time retaining the heat, saving fuel, and rendering the boilers more lasting.—14th October.—6 months.

A METEOROLOGICAL TABLE: comprising the Observations of Dr. BURNBY at Gosport, Mr. CARY in London, and Mr. VELL at Boston.

Days of Month, 1824.	Gosport, at half-past Eight o'Clock, A.M.										Clouds.					Barometer, in Inches, &c.			Thermometer.			RAIN.		WEATHER.		
	Barom. in Inches, &c.	Thermo.	Temp. of Sp. Water.	Hygrom.	Wind.	Evapora- tion.	Rain near the Ground	Cirrus.	Cirrocum.	Cirrus.	Stratus.	Cumulus.	Cumulostr.	Nimbus.	London. 1 P.M.	Bost. 8 1/2 A.M.	London. 1 P.M.	Boston. 8 A.M.	London.	Boston.	London.	Boston.	London.	Boston.		
	Barom. in Inches, &c.	Thermo.	Temp. of Sp. Water.	Hygrom.	Wind.	Evapora- tion.	Rain near the Ground	Cirrus.	Cirrocum.	Cirrus.	Stratus.	Cumulus.	Cumulostr.	Nimbus.	London. 1 P.M.	Bost. 8 1/2 A.M.	London. 1 P.M.	Boston. 8 A.M.	London.	Boston.	London.	Boston.	London.	Boston.		
Sept. 26	30.08	47	53.15	63	N.	0.300	0.300	1	1	1	1	1	1	1	30.05	29.80	30.05	29.80	45.52	42.0	Fair	...	Fair	...	Fine	
27	29.54	49	60	E.	.145	.145	1	1	1	1	1	1	1	29.58	29.40	29.58	29.40	42.47	41.48	Showery	0.40	Showery	...	Cloudy	
28	29.83	44	62	NW.060	1	1	1	1	1	1	1	29.93	29.60	29.93	29.60	39.52	42.40	Fair	Fair	Fine	
29	29.90	51	58	S.50	1	1	1	1	1	1	1	29.95	29.75	29.95	29.75	45.58	45.45	Fair	Fair	Fine	
30	29.62	60	76	S.660	1	1	1	1	1	1	1	29.55	29.45	29.55	29.45	54.58	59.55	Fair	Fair	Cloudy	
Oct. 1	29.10	60	53.60	75	SE.380	1	1	1	1	1	1	1	29.17	28.95	29.17	28.95	57.59	56.58	Rain	Rain	Rain	
2	29.33	57	67	S.100	1	1	1	1	1	1	1	29.56	29.07	29.56	29.07	55.60	56.54	Stormy	Stormy	Fine, rain p.m.	
3	29.77	58	66	SW.	.35	.030	1	1	1	1	1	1	1	29.89	29.45	29.89	29.45	57.64	52.53	Fair	0.60	Fair	Fine	
4	29.77	59	79	E.186	1	1	1	1	1	1	1	29.83	29.60	29.83	29.60	53.62	56.54	Fair	Fair	Cloudy	
5	29.60	60	76	E.120	1	1	1	1	1	1	1	29.65	29.35	29.65	29.35	56.60	59.58	Rain	Rain	Cloudy, — rain at night	
6	29.40	61	77	E.	.20	.255	1	1	1	1	1	1	1	29.42	29.20	29.42	29.20	58.60	60.57	Rain	Rain	Cloudy, [night	
7	29.29	62	53.75	77	SW.090	1	1	1	1	1	1	1	29.30	28.95	29.30	28.95	60.64	57.60	Showery	Showery	Rain. Th. 3 p.m. 66.	
8	29.28	59	74	E.	1	1	1	1	1	1	1	29.40	29.20	29.40	29.20	57.65	56.60	Fair	Fair	Cloudy, rain a.m.	
9	29.60	58	72	NW.	.25	.030	1	1	1	1	1	1	1	29.64	29.15	29.64	29.15	56.60	48.56	Fair	Fair	Cloudy	
10	29.54	55	70	SE.	1.095	1	1	1	1	1	1	1	29.41	28.30	29.41	28.30	47.50	55.48	Rain	1.40	Rain	Cloudy, rain at nt.	
11	28.85	58	78	S.260	1	1	1	1	1	1	1	28.93	28.75	28.93	28.75	55.57	52.54	Rain	Rain	Cloudy, do.	
12	28.78	51	69	N.	.40	.090	1	1	1	1	1	1	1	28.92	29.75	28.92	29.75	50.50	39.47	Rain	Rain	Stormy, rain a.m.	
13	29.37	40	66	N.	1	1	1	1	1	1	1	29.45	29.20	29.45	29.20	37.44	37.38	Fair	Fair	Fine [and p.m.	
14	29.57	41	53.40	64	W.105	1	1	1	1	1	1	1	29.63	29.32	29.63	29.32	36.51	36.43	Rain	Rain	Cloudy, rain a.m.	
15	29.62	44	64	N.	.20	.065	1	1	1	1	1	1	1	29.70	29.50	29.70	29.50	34.41	34.41	Fair	Fair	Cloudy	
16	29.87	35	67	N.	1	1	1	1	1	1	1	29.95	29.70	29.95	29.70	33.45	33.38	Fair	Fair	Cloudy	
17	30.05	37	64	NW.	1	1	1	1	1	1	1	30.04	29.80	30.04	29.80	33.49	34.36	Fair	2.00	Fair	Cloudy, rain a.m.	
18	30.15	39	62	NW.	.25	.015	1	1	1	1	1	1	1	30.17	29.93	30.17	29.93	34.51	42.36	Fair	Fair	Cloudy, do.	
19	30.16	52	67	SW.050	1	1	1	1	1	1	1	30.11	29.80	30.11	29.80	46.56	51.48	Fair	Fair	Cloudy	
20	30.07	52	66	W.	1	1	1	1	1	1	1	30.10	29.65	30.10	29.65	52.56	50.47	Fair	Fair	Cloudy	
21	29.98	50	53.40	64	SW.	.30	1	1	1	1	1	1	1	30.05	29.65	30.05	29.65	54.57	50.50	Fair	Fair	Fine	
22	29.93	56	74	SE.025	1	1	1	1	1	1	1	29.94	29.65	29.94	29.65	50.59	54.53	Cloudy	Cloudy	Fine	
23	29.94	58	71	SW.	1	1	1	1	1	1	1	29.98	29.60	29.98	29.60	52.60	55.54	Cloudy	Cloudy	Fine	
24	29.82	58	72	E.015	1	1	1	1	1	1	1	29.82	29.60	29.82	29.60	55.62	60.52	Fair	0.02	Fair	Cloudy	
25	29.54	58	53.40	74	SW.	.40	.060	1	1	1	1	1	1	1	29.56	29.22	29.56	29.22	57.60	55.55	Showery	Showery	Cloudy	
Averages:	29.64	52.30	53.45	69.5	3.03	4.136	21	16	27	8	25	17	23	29.68	29.43	29.68	29.43	48.52	47.49	4.42	2.82	4.42	2.82	4.42	2.82

THE
PHILOSOPHICAL MAGAZINE
AND JOURNAL.

30th NOVEMBER 1824.

LV. *Contributions to our Knowledge of Chemical Bodies.*
By Mr. W. HERAPATH*.

No. 1. *On the Combinations of Oxygen.*

A DESIRE to know the state in which oxygen exists after combination, induced me in 1821 to commence a set of experiments upon the metallic oxides; in the course of which, many new facts have presented themselves, which I conceive are worth recording; and under this impression I shall venture to make them public; although from the tedious manipulations required to purify the different substances, the necessity of taking their density at one particular temperature, and the short time I can devote to such pursuits, I find it impossible to present a complete series of the metals and their oxides, as was my original intention. In following up my ideas on those bodies, I had expected to derive some information from the labours of others; but unfortunately, I found that the oxides had been scarcely at all operated on, as far as regarded their densities;—at least I am not aware that any table of their densities was ever published: and although it had been considered of sufficient importance to ascertain the density of the various metals; yet, from the inattention of the experimenters to their purity,—to the propriety of their being reduced without alkaline fluxes, to their being allowed to cool slowly in the crucible in which they were melted, and to the neglect of registering the temperature at which the specific gravities were taken,—there is so much confusion, that it is with great difficulty I can select enough to form a table. I have done so here: but as I consider it absolutely necessary that all the experiments should be repeated; if this notice fails to call the attention of chemists to this department of science, I shall extend my task to it: but from the magnitude of the under-

* Read before the Society of Inquirers of Bristol, September 20, 1824.

taking it must be long before it will be complete. In the mean time I shall produce evidence enough to show what I conceive to be general laws, leaving it to futurity to give them absolute precision.

As a basis, I have taken, as accurately as I could, the densities arranged below: some few are of no value to this inquiry; but as they may be serviceable to others, I shall give the whole list:

Cadmium, perfectly pure	62°	8·659
Cadmium, brown oxide	62	8·183
Cadmium, carbonate, dried at 180°	63	4·420
Copper, not poled	65	8·510
The same copper, poled	64	8·843
Copper, in grains	64	8·6006
Copper, pure, melted, and cooled in crucible	62	8·900
Copper, red oxide, as made from acetate	62	6·093
Copper, red oxide, by heating copper	62	6·052
Copper, black oxide, from heating with nitre	62	6·401
Copper, sulphuret	64	5·792
Tin of commerce, containing lead	64	7·602
Tin, hammered	64	7·600
Tin, remelted, and allowed to cool in crucible	64	7·5565
Tin, pure, as reduced from white oxide, }	62	7·285
— hammered the same		
Tin, gray oxide, from muriatic acid, by potash	62	6·666
Tin, white oxide	64	4·933
Tin, white oxide, heated till yellow	62	6·639
Lead, pure	62	11·352
Lead, yellow oxide	64	9·277
Lead, red oxide	60	9·096
Lead, puce-coloured oxide	62	8·902
Arsenic, pure (metallic)	62	5·672
Arsenious acid, glacial	63	3·729
Bismuth	61	9·831
Bismuth, white oxide	62	6·7608
Bismuth, white oxide, heated till yellow	65	8·211
Bismuth, sulphuret	58	7·591
Iron, black oxide, as produced in oxygen gas	62	5·300
Iron, red oxide, from nitric acid	62	4·959
Mercury, black oxide	62	10·69
Mercury, red, from nitric acid	64	11·074
Mercury, red oxide (<i>per se</i>)	65	11·085
Mercury, proto-chloride (calomel)	60	6·707
Silver, brown oxide	62	7·143
Silver, chloride	66	5·129

Manganese

Manganese, brown oxide	62½°4·7264
Nickel, black oxide	62 4·846
Cobalt, black oxide	62 5·322
Tungstic acid	62 5·274

The first fact I noticed in taking those densities, was that *the oxides were nearly, if not all, hygrometric*, the quantity of water they abstract from the atmosphere being regulated by certain laws, which I shall endeavour to detail and explain in a future paper. I conceive the overlooking this hygrometric property of the oxides to be one of the principal causes why the results of different chemists are so discordant, that instead of calculating the equivalent weights of metals from their oxides, they are obliged to have recourse to their salts for that purpose. Let us take an example by way of illustration.

I converted 100 grains of tin into gray oxide, by solution in muriatic acid, precipitating by potassa while recent: on washing, drying, and weighing the oxide produced, it amounted to 124·92; in a few minutes it became 126 grains; and in 48 hours it had absorbed as much moisture from the atmosphere as increased its weight to 127·32. Now if we suppose two experimenters at work upon the same metal, the one weighing his oxide hot, the other leaving it to a convenient opportunity, their results would differ nearly 3 per cent.; or if the second only deferred weighing a few minutes, they would not agree by 1 per cent.

There appears to be an intimate connexion between the density of a metal and the quantity of oxygen it unites with; so much so, that I think when the course of accurate experiments is complete, which I have explained above, the following will turn out to be a general law.—*All metals combine with oxygen in the inverse ratio of their densities**.

In order to show the extent of evidence which has produced this opinion, I shall give a table, where the metals which are best known are arranged in the order of their densities, from the heaviest down to the lightest, with a column containing the smallest quantity of oxygen with which 100 parts of those metals are known to unite (protoxides); where it will be perceived, that as the metals become lighter, the quantity of oxygen they combine with increases.

* We would here remark, that there are several instances of combination with oxygen among the metals, that appear to throw considerable doubt upon the existence of this law: 100 parts of potassium, for instance, the density of which is 0·85, take 20 parts of oxygen to form potash; and the same quantity of sodium, density 0·97, requires 33·33 of oxygen to produce soda; both alkalies being protoxides.—ED.

Table of Protoxides.

Name.	Density. Water = 1.	Oxygen. to 100 Met.	Name.	Density. Water = 1.	Oxygen. to 100 Met.
Platinum	21·47	4·42	Nickel	8·380	27·40
Gold	19·258	4·02	Cobalt	8·340	27·58
Tungsten	17·33	8·33	Manganese	8·013	28·107
Mercury	13·568	4·00	Iron	7·847	28·570
Lead	11·352	7·69	Tin	7·285	13·56*
Silver	10·474	7·27	Zinc	7·121	24·24
Bismuth	9·822	11·26	Antimony	6·424	18·18
Copper	8·900	12·50	Tellurium	6·115	25·00
Cadmium	8·659	14·28	Arsenic	5·762	31·58
Molybdenum	8·611	16·66			

Here we see that the numbers in the 3rd column have an evident *tendency to increase* downwards:—that platinum, a metal $21\frac{1}{2}$ times as heavy as water, combines with about 4 per cent. of oxygen; while arsenic, about $5\frac{1}{2}$ times as heavy as water, combines with 31 per cent. Tungsten, nickel, cobalt, manganese, and iron, are greater numbers than they should be; and it is strange that all of them, except manganese, are such as we should expect not to have found the protoxides of, because the oxides in the table contain oxygen, compared with the peroxides, as 2 to 3, leaving it probable that there is an undiscovered oxide of each, containing oxygen as 1. In the oxides of manganese there is great confusion. Berzelius finds two with less oxygen than the one in the table: but the theory of equivalents and the experiments of good chemists plead against the first of them; while the second of them I have not introduced, because it is not well defined, although it would better accord with the table.

My experiments on the oxide of tin from muriatic acid, make it composed of 100 metal + 24·8 oxygen (instead of 13·56), in which case that metal would accord: there only remains antimony, the oxides of which are still more confused than those of manganese.

I am the more induced to think that this law will be proved, from the circumstance that the unmetallic bodies I find, as far as they have been investigated, seem to be governed by the same laws.

* I make this $100 + 24·92$.

Table of Non-metallics.

Name.	Density. Air = 1.	Oxygen to 100.	Name.	Density. × Oxygen.
Iodine vapour	8·6780	32·4	Iodic acid	
Chlorine	2·5000	22·2	Protoxide	} 55·55
Sulphur vapour	1·1111	50·0	chlorine	
Azote	·9722	57·1	Hypo-sulphu-	} 55·55
Carbon vapour	·4160	133·0	rous acid	
Hydrogen	·0694	800·0	Protoxide azote	55·51
Boron	} unknown		Carbonic oxide	55·46
Phosphorus			Water	55·52
Fluorine				
Selenium				

Here there is such an exact agreement in 5 out of 6, that the density multiplied by the oxygen gives one constant number. Iodine is the only exception, the product of which is much greater than it should be: but as iodine was only discovered in 1812, as there is only one of its combinations with oxygen (iodic acid) known, and as all the others combine with oxygen in more than one proportion, I have strong hopes that future investigations will cause this anomaly to disappear; particularly as chlorine, which is very similar in many respects to iodine, combines in such proportions as would with iodine give the true number, viz. 1 atom chlorine + 1 atom oxygen.

A familiar example of the combination of oxygen with a metal, and the condensation resulting, will serve to give a clear idea of what I conceive to be another law.—*Oxygen in uniting to a metal has its bulk reduced to a small measure of the bulk of the metal.*

Lead, the density of which at 62° when perfectly pure and allowed to cool gradually, is 11·352, water being 1; takes of oxygen, to form its protoxide, 7·692 to 100 metal: that is, a cubic inch of lead, weighing 2886½ grains, unites with 222 grains or 655 cubic inches of oxygen gas; but the 656 cubic inches are now reduced to very nearly 1½ cubic inch, for the oxide would only displace that quantity of water, having a density of 9·277; therefore, we must suppose the cubic inch of lead to have condensed the 655 cubic inches of oxygen to ½ of its own bulk, or to 1-2036th part of the space it occupied in the state of gas. The following list will show that the same law obtains with the other metallic oxides.

Bulk in grains.
Water. Cubic Inches.

Lead Protoxide.

Lead, 1 cubic inch at 11.352 weighs . 2886.6 grains = .
Takes 655 cubic inches oxygen . 222.
Making 3108.6 of yellow protoxide, at 9.277 sp.gr. = 332.

Oxygen condensed 2036 times.

Lead Deutoxide.

Lead, 1 cubic inch weighs . . 2886.6 grains =
Takes 982 cubic inches oxygen . 333.
Making 3219.6 grains red deutoxide, at 9.082 =

Oxygen condensed 2472 times.

Lead Tritoxide.

Lead, 1 cubic inch weighs . . 2886.6 grains =
Takes 1310 cubic inches oxygen . 444.
Making 3330.6 grains pure tritoxide, at 8.903 =

Oxygen condensed 2761 times.

Mercury Protoxide.

Mercury, 1 cubic inch at 13.568 weighs 3426.19 grains =
Takes 404 cubic inches oxygen 137.
Making 3563.19 grains black protoxide, at 10.69 =

Oxygen condensed 1262 times.

		Bulk in grains.		Cubic Inches.	
		Water.			
<i>Mercury Peroxide.</i>					
Mercury, 1 cubic inch weighs	3426·19 grains =	·	·	252·52	1 or 3
Takes 808 cubic inches oxygen	274·09	·	·	81·62	$\frac{3}{3}$ to 1
Making 3700·28 grains red peroxide, at 11·074 =				<u>334·14</u>	
Oxygen condensed 2500 times.					
<i>Acid of Tungsten.</i>					
Tungsten, 1 cubic inch at 17·4 weighs	4393·8 grains =	·	·	252·52	1 or 1
Takes 3243 cubic inches oxygen.	1098·4	·	·	788·85	$3\frac{1}{2}$ to 3
Making 5492·2 grs. yellow tungstic acid, at 5·274 =				<u>1041·37</u>	
Oxygen condensed 1039 times.					
<i>Iron Protoxide.</i>					
Iron, 1 cubic inch at 7·843 weighs	1980·40 grains =	·	·	252·52	1 or 1
Takes 1669 cubic inches oxygen	565·82 grains	·	·	227·90	$\frac{9}{10}$ to 1
Making 2546·22 grains black protoxide, at 5·3 sp.gr. =				<u>480·42</u>	
Oxygen condensed 1850 times.					
<i>Iron Peroxide.</i>					
Iron, 1 cubic inch weighs	1980·40 grains =	·	·	252·5	1 or 4
Takes 2504 cubic inches oxygen	848·74	·	·	318·	$1\frac{1}{4}$ to 5
Making 2829·14 grains red oxide, at 4·959 =				<u>570·50</u>	
Oxygen condensed 2003 times.					

		Bulk in grains.	Cubic Inches.
		Water.	
<i>Nickel Peroxide.</i>			
Nickel, 1 cubic inch at 8.38 weighs	2116.11 grains =	252.52	1 or 2
Takes 2882 cubic inches oxygen	976.66 grains	385.69	1½ to 3
Making 3092.77 grains black oxide, at 4.846 sp. gr. = 638.21			
Oxygen condensed 1896 times.			
<i>Copper Protoxide.</i>			
Copper, 1 cubic inch at 8.9 weighs	2247.42 grains =	252.52	1 or 3
Takes 829 cubic inches oxygen	280.92	162.53	¾ to 2
Making 2528.34 grains red oxide, at 6.093 =		415.05	
Oxygen condensed 1295 times.			
<i>Copper Peroxide from Nitre.</i>			
Copper, 1 cubic inch weighs	2247.42 grains =	252.52	1 or 4
Takes 1654 cubic inches oxygen	561.84	186.35	¾ to 3
Making 2809.26 grains black oxide, at 6.401 =		438.87	
Oxygen condensed 2235 times.			
<i>Silver Protoxide.</i>			
Silver, 1 cubic inch at 10.474 weighs	2644.89 grains =	252.52	1 or 5
Takes 567 cubic inches oxygen	192.35	144.68	½ to 3
Making 2837.24 grains brown oxide, at 7.143 =		397.20	
Oxygen condensed 989 times.			

Tin Peroxide.
 Tin, 1 cubic inch at 7.285 weighs
 Takes 1477 cubic inches oxygen =
 1839.60 grains =
 500.57
 Making 2340.17 grains yellow oxide, at 6.639 sp.gr. = 352.48
 Oxygen condensed 3694 times.

Arsenious Acid.
 Arsenic, 1 cubic inch at 5.672
 Takes 1334 cubic inches oxygen =
 1432.2 grains =
 452.27
 Making 1884.47 grains of white oxide, at 3.729 =
 Oxygen condensed 1334 times.

Brown Oxide of Manganese.
 Manganese, 1 cubic inch at 8.013
 Takes 2812 cubic inches =
 2023.44 grains =
 953.02
 Making 2976.46 grains of brown oxide, at 4.726 =
 Oxygen condensed 1886 times.

As this paper has extended to so great a length, I shall not make any further comments upon it; but I would mention, for the information of those who may experiment after me, that it is not only necessary to drive all the water from the oxides before weighing, but they should be boiled in the specific gravity bottle, in order to disengage the air which some of them pertinaciously hold—without these precautions they can obtain no true result.

Sept. 20, 1824

WILLIAM HERAPATH.

LVI. *On the Calculus of Variations.* By JOHN WALSH, Esq.

To the Editors of the Philosophical Magazine and Journal.

Gentlemen,

PERHAPS you will be so good as to insert the following paper in the next Number of your very valuable Journal, if not too much preoccupied.

I have the honour to be, gentlemen,
Your much obliged servant,

Sept. 30, 1824.

JOHN WALSH.

Let AB be any straight line bisected in C, and let E be any other point in AB, then

$$(AB - AC \mp CE)(AC \pm CE) = AB \times AC - AC^2 \pm (AB - 2AC) CE - CE^2.$$

or, as AB is equal to 2AC,

$$(AB - AC \mp CE)(AC \pm CE) = AB \times AC - AC^2 - CE^2.$$

The preceding is the demonstration of prop. v. book 2, of the Elements of Euclid. We see by it, as CE^2 is negative, whether CE itself is positive or negative, that the maximum rectangle under the two segments of any given straight line takes place when the line is bisected. The condition of maximum requires, therefore, that the coefficient of CE the arbitrary magnitude added to and taken from AC, should be nothing, and that CE^2 should be negative.

Clothing the preceding equation in the notation of the differential calculus, there is given, in the case of maximum,

$$adx - 2xdx = 0$$

in which $a = AB$, $x = AC$, $dx = CE$, dx , being considered indefinitely small. Clothing this last in the notation of the calculus of variations, there is given, in the case of maximum,

$$\int \delta(adx - 2xdx) = 0.$$

$$\int \{ad\delta x - 2x\delta\delta x - 2\delta x dx\} = 0.$$

Integrating by parts, the integral is,

$$adx - 2x\delta x + \int \{2\delta x dx - 2\delta x dx\}.$$

It is seen, that the terms remaining under the integral sign destroy one another. We are left, therefore, by the calculus of variations, at the point at which we set out, and we have not

not still for the determination of the maximum, but the original equation,

$$adx - 2x dx = a \delta x - 2x \delta x = 0.$$

I shall take now what is called the differential equation of the curve of quickest descent. Finding the variation, and integrating, then

$$\frac{\delta s}{u} + \int \left\{ \frac{\delta s du}{u^2} - \frac{ds \delta u}{u^2} \right\} = 0.$$

The terms remaining under the integral sign destroying one another, there is still for the determination of the minimum, only, the original equation,

$$\frac{\delta s}{u} = \frac{ds}{u} = 0.$$

Thus, it is first of all demonstrated, by the fifth proposition of the second book of Euclid, that the calculus of variations is no calculus at all. Its nonentity is self-evident; for it consists in ascending from the second term of the development of a binomial to the third, and then redescending again, leaving us at the point at which we set out; doing and then undoing to no purpose. The Institute of France was too hasty in the reports which it gave of every paper, in fact, which I addressed to it.

“ M. Walsh croit que cette demonstration est la seule rigoureuse qui ait été donnée jusqu’ à présent pour le cas dont il s’agit. Cependant il suffit d’avoir lu les ouvrages d’Euler ou des géomètres qui ont écrit apres lui sur cet objet, pour être bien convaincu que la formule du binome est depuis longtemps établie en toute rigueur.”—*Extrait du procès-verbal de la Séance du Lundi, 24 Décembre 1821.*

“ L’auteur s’est proposé d’établir un théorème qu’on peut exprimer comme il suit : Chaque terme du développement de la n^{me} puissance du binome surpasse en valeur numérique la somme des termes suivans.—Ce théorème suppose évidemment que le second terme du binome à une valeur numérique inférieure à celle du premier.”—*Lundi, 24 Février 1823.*

With respect to the development of a binomial when the exponent is a negative whole number, let

$$(x+h)^{-n} = \frac{1}{(x+h)^n} = \frac{1}{x^n + z}$$

developing the right hand member by division, and arranging according to h , I get,

$$(x+h)^{-n} = x^{-n} - nx^{-n-1}h + \frac{n(n+1)}{1.2} x^{-n-2}h^2 - \&c.$$

The preceding is the demonstration to which the first of the preceding

preceding extracts refers. The Institute of France calls it a pretended demonstration. Then all our numerical divisions are only pretended. I have given the only general demonstration of the formula of the binomial that has as yet appeared. It was read by the Royal Society of London, June 6, 1821. Had I sent it to the Institute of France, it would have been called pretended, and rejected. The second extract refers to the dinomial theorem. The report asserts, that the theorem evidently supposes, the second term of the binomial to be less than the first. The paper of mine in the Philosophical Magazine for last June, demonstrates that the Institute is in error in coming to such a conclusion; for the theorem is demonstrated in that paper when both the terms of the binomial are equal to each other. The dinomial theorem is a general law of all series. It has banished more errors from algebra than has the system of Copernicus banished from physical astronomy. The following is its enunciation in the most general sense.

In every series, the sign of any term after the first, is the sign of that term combined with all those that follow it.

This grand theorem has banished fluxions, differentials, and the calculus of variations, and has extended the domain of algebra without limit.

The following is from the last report which the Academy of Sciences has given with respect to the binomial calculus, that I have received:

“Les commissaires ont été d’avis que les memoires de M. Walsh n’apprennent rien de nouveau, ils croient ne devoir attacher aucune importance au nom que l’auteur voudra donner à son calcul, et se dispenseront de fixer plus long-temps sur ces objets l’attention de l’Académie.”

“(Signé) POISSON, CAUCHY, Rapporteur.”
“Lundi, 16 Juin, 1823.”

The influence which the infinitesimal calculus has so long exercised in geometry and analysis, has not permitted the Royal Academy of Sciences of Paris to perceive clearly its way through the binomial calculus. The preceding demonstration of the fifth proposition of the second book of Euclid, first, demonstrates the absurdity of the logic of the infinitesimal calculus; secondly, it develops the general theory of maxima and minima; and, thirdly, it demonstrates the nonentity of the calculus of variations.

Cork, Sept. 30, 1824.

LVII. *On the Transformation of the Solutions of a Periodical Functional Equation.* By JOHN HERAPATH, Esq.

IF $\psi^n x = x$, I have found by a very simple and direct process that the complete solution is

$$\psi^v x = \phi \sin \left\{ \frac{2kv\pi}{n} + \sin^{-1} \phi^{-1} x \right\} \quad (1)$$

where π is the semi-perimeter to radius 1, k any integer, and ϕ any arbitrary function; also v, n any numbers whatever, rational, irrational, or imaginary. The function *sin* may also be changed into *cos, tan, sec, &c.* if we please; and the only condition that appears necessary, if ϕ should contain an inverse circular function, is not to blend the operations, but to let each act separately and distinctly.

Let us denote (1) by

$$\psi^v x = \phi f^v \phi^{-1} x \quad (2)$$

and in any other case, for instance, when $\psi_r^r x = x$, let it be

$$\psi_r^v x = \phi_r f_r^v \phi_r^{-1} x \quad (3)$$

Then if in (2) v be expounded by $\frac{n}{r}$ we shall have

$$\psi_r^{\frac{n}{r}} x = \phi f^{\frac{n}{r}} \phi^{-1} x$$

which by (1) is equal to $\psi_r x$. Therefore $\psi_r^{\frac{n}{r}} = \psi_r$ and $\psi_r^{\frac{tn}{r}} = \psi_r^t$, that is, *a periodic function of any order is a given order of a periodic function of any other order, both taken completely.* This result is also easily obtained *a priori*; but there is another consequence flowing from it, that seems, to me at least,

of a more novel character. For instance, because $\psi_r^{\frac{n}{r} s} = \psi_r^s$
 $\phi f^{\frac{n}{r} s} \phi^{-1} x = \psi_r^{\frac{n}{r} s} x = \phi f^s \phi^{-1} \phi_r f_r^s \phi_r^{-1} x = \phi f^s \phi^{-1} \phi_r f_r^{\frac{ns}{r}} \phi_r^{-1} x$
 $\phi_r^{-1} x$: that is $\phi = \phi_r$. In other words, *if there be any two arbitrary functions ϕ, ϕ_r perfectly unlimited, then is $\phi = \phi_r$; or they are identically the same.* This singular consequence is evident, if we consider that a function perfectly arbitrary must virtually contain at every instant every form that can be given it. Two such absolutely arbitrary functions must therefore simultaneously comprehend all and the same possible forms, and consequently be equally and identically the same. I do not mean to contend that an arbitrary function may not have at any time any particular form the problem requires; nor that

two arbitrary functions of the same variable may not simultaneously have very unequal forms under certain circumstances; but when quite free and unrestricted, then they are identical.

To enter into a further discussion of this fact of identity would lead me into details inconsistent with the object of the present paper; but the utility and importance of it in the theory of arbitrary functions are obvious to any one acquainted with this calculus.

Suppose we have $f\psi x = \psi \alpha x$, α and f being given periodics of the second order, and it be required to determine ψ :

Assume $f\psi x = \psi \alpha x \cdot \phi x^v$, which coincides with the question when $v=0$ whatever be the form of ϕ . Then substituting αx for x , and taking the f function on both sides, we get

$$\psi \alpha x = f \{ \psi x \cdot \phi \alpha x^v \} = \frac{f\psi x}{\phi x^v},$$

which differentiated with respect to v alone, and then reduced, becomes

$$\frac{f\psi x}{\psi x \cdot f' \psi x} = - \frac{\log \phi \alpha x}{\log \phi x} = - \frac{\phi \alpha x}{\phi x} \quad (4)$$

putting f' for the differential function of f , and including in the arbitrary function the log.

A similar solution would come out, if we had as well as v introduced an arbitrary factor b , and after the differentiation with respect to b and v , put $b=1$ and $v=0$. Both of these methods, however, fail in giving the value of ψx when $\frac{fx}{xf'x}$ is a constant quantity; which happens in the simple cases of fx being x , $-x$, or $\frac{1}{x}$. In these cases the solution is

obtained by the extension of a neat and simple artifice employed by Mr. Babbage in the solution of $\psi x = \psi \alpha x$. Substitute $v\psi \alpha x + b\phi x$ for $\psi \alpha x$; change x into αx ; differentiate with respect to v and b after eliminating $\psi \alpha x$; divide by dv or db ; and then putting $v=1$, $b=0$, we obtain

$$-f\psi x = f' \psi x \cdot (\psi x + \phi \alpha x) + \phi x. \quad (5)$$

Again: if we have $f\psi x = \psi \alpha^r x^*$, the condition being $\alpha^n x = x$ where n and r are any rational numbers whatever:

Then assuming $f\psi x = \psi \alpha^r x \cdot \phi x^v$, we have by continually substituting for ψ function its value

$$\psi x = f^{-1} \{ (\phi x)^v f^{-1} \{ (\phi \alpha^r x)^v f^{-1} \{ (\phi \alpha^{2r} x)^v \dots \\ f^{-1} \{ (\phi \alpha^{(q-1)r} x)^v \psi x, \quad (6)$$

where each f^{-1} applies to all the expression on the right

* Since writing the above I have succeeded in discovering a solution to this equation of the monomial form, even when r, n are irrational or imaginary. hand

hand of it, and q is the prime numerator of $\frac{n}{r}$. The number of f^{-1} s, or terms, must therefore be q . If now we put generally $A_i = \phi \alpha^{rt} x$ embracing the log. in ϕ , and differentiate (6) with respect to v , we shall find

$$0 = A_0 f^{1-q} \psi x + f^{-1+2-q} \psi x \cdot \{ A_1 f^{2-q} \psi x + f^{-1+3-q} \psi x \cdot \{ A_2 f^{3-q} \psi x \dots f^{-1+q} \psi x \} A_{q-1} \psi x \quad (7)$$

where the several orders of $f \psi x$ are factors to all the expression following on the right hand, and the acute accent in each case over the -1 signifies the differential function of the inverse function of f , the other indices denoting simply the direct or inverse functions of f as they happen to be positive or negative; so that generally $f^{p'+q} x$ implies the $\frac{df^{p'} x}{dx}$ function of $f^q x$.

Otherwise thus:

Put for $\psi \alpha^r x = b \phi x + v \psi \alpha^r x$, and the equation proposed stands

$$f \psi x = b \phi x + v \psi \alpha^r x \quad (8)$$

which becomes $\psi x = f^{-1} \{ b \phi x + v f^{-1} \{ b \phi \alpha^r x + v f^{-1} \{ b \phi \alpha^{2r} x + \dots v f^{-1} \{ b \phi \alpha^{(q-1)r} x + v \psi x \} \} \} \} \quad (9)$

by successively substituting for the last number its value derived from (8). In this expression (9) the same import is given to each f^{-1} as in (6). Differentiating with respect to b and v ; putting afterward $b=0$ and $v=1$; letting $A_i = \phi \alpha^{rt} x$; and comprehending in ϕ the quotient $\frac{db}{dv}$, we shall find

$$A_0 + f^{1-q} \psi x + f^{-1+2-q} \psi x \cdot \{ A_1 + f^{2-q} \psi x + f^{-1+3-q} \psi x \cdot \{ A_2 + f^{3-q} \psi x + \dots f^{-1+q} \psi x \} A_{q-1} + \psi x = 0 \quad (10)$$

the orders and accented f s denoting the same as in (7).

It may here be observed, that these expressions (7), (10) are not necessarily confined to periodic functions. In case, however, αx is not a periodic, we must put every where $\psi \alpha^{qr} x$ for ψx . When αx is a periodic and of the n th order, $f x$ must obviously be a periodic too, of the order $\frac{n}{r}$. Should in this instance $f x$ not be a periodic, the arbitrary function will receive a certain limitation, which being inconsistent with the perfectly unlimited form in which it is introduced, and which

it

it should therefore invariably maintain, renders the proposed equation impossible in a general point of view. It should not however hence be inferred, that when an equation is generally it is universally impossible. Restrictions may be introduced which may render a generally impossible equation, particularly possible; as for instance, in the problem of tangents considered by Messrs. Euler, Wallace, Ivory, Herschel, &c.

From either of the expressions (7) or (10) the form of ψx may be determined, and hence the general transformation of the complete solution (1) into any other complete solution, where the form without the arbitrary function coincides with any particular form we please. For suppose $\alpha^n x = x$, and that our complete solution is $\phi \alpha^r \phi^{-1} x$, it is required to find the form of ϕ , so that this complete solution may be transformed into a complete solution with the particular form $f^t x$. We have then $f^t x = \phi \alpha^r \phi^{-1} x$, or $f^t \phi x = \phi \alpha^r x$ to find the form of ϕ involving an arbitrary function. The condition

of f in this case is evidently $f^{\frac{tn}{r}} x = x$. By substituting in (7) or (10) f^t for f , and ϕ for ψ , we have an equation involving only ϕx and arbitrary functions of x , $\alpha^r x$, $\alpha^{2r} x$, &c., from which ϕx may be determined in a given function of an arbitrary function of x , and the various orders of $\alpha^r x$. Giving to the arbitrary function a particular form, we shall have βx for some particular form of ϕ , and therefore generally

$$\phi x = \phi, \beta x \text{ and } \phi^{-1} x = \beta^{-1} \phi^{-1} x$$

where ϕ , may be perfectly arbitrary. Consequently

$$f^t x = \phi \alpha^r \phi^{-1} x = \phi, \beta \alpha^r \beta^{-1} \phi^{-1} x,$$

and the complete solution transformed into the particular form $f^t x$ is

$$\psi^t x = \phi, f^t \phi^{-1} x,$$

in which $\psi^{\frac{tn}{r}} x = x$.

The brevity to which I am confined in such a paper as the present, prevents me from detailing the numerous applications and powers of the two important theorems we have just deduced. I shall therefore content myself with showing their utility in the solution of a problem not, I believe, heretofore attempted.

Let us have given the form of $f^r x$, the condition being f

$f^n x = x$: it is required to find the form of any other order, $f^t x$; r, n, t being any numbers whole or fractional.

We of course here suppose that the form of $f^r x$ being known, common algebra will give us the form of $f^{-r}, f^{-2r}, f^{-3r} \dots$

Assume $f^r x = \psi \alpha^r \psi^{-1} x$, in which α is the particular form of ψx in our complete solution (1); and which is therefore always known for every order. For x put ψx , and we have $f^r \psi x = \psi \alpha^r x$. Determine the form of ψx from (7) or (10) by substituting f^r for f , and making ϕx in the expression employed $= x$. Then we shall have

$$f^t x = \psi \alpha^t \psi^{-1} x$$

where α^t and ψ are known forms.

As an example, let $f x = b - x$, and let it be required to find the form of $f^{\frac{1}{2}} x$.

Now, we easily see that $f^{\frac{1}{2}} x$ must be a function of the fourth order. The difficulty, however, does not lie in finding a function of this or of any other order, but in finding such a one that its second function shall have the particular form assigned to f . By putting in (1) $k = 1$, we have

$$b - x = \psi(-\psi^{-1} x)$$

and, since $f^2 x = -1$, by (5)

$$b - \psi x = \psi x + \phi(-x) - \phi x.$$

Therefore $\psi x = \frac{b - \phi(-x) + \phi x}{2} = \frac{b + 2x}{2}$, and $\psi^{-1} x = \frac{2x - b}{2}$, by putting $\phi x = x$.

Again: by (1), when $k = 1$ and $v = \frac{1}{2}$ and because $\alpha x = -x$,

$$\alpha^{\frac{1}{2}} x = -\sqrt{1 - x^2};$$

and therefore

$$f^{\frac{1}{2}} x = \psi \alpha^{\frac{1}{2}} \psi^{-1} x = \frac{b - \sqrt{4 - (2x - b)^2}}{2}.$$

An arbitrary function might here have been easily introduced; since, instead of making $\phi x = x$, we might have made it equal to ϕx , any function whatever of x , that becomes $-\phi x$ by changing x into $-x$. Any odd power of x is an obvious case. Such an arbitrary function would disappear in the given particular form $f x$.

We are now therefore in possession of a general and direct rule for extracting any functional root whatever of a periodic, and that too in finite terms.

As another example of the application of the preceding theorems, take the equation $\psi^p \alpha^r x = \psi^q x$, the condition being $\alpha^n x = x$, where p, q, r, n are any numbers. A particular case of this equation has been considered by Mr. Babbage in the 68th Prob. of his and Messrs. Herschel and Peacock's "Examples," &c.

Take the ψ^{-p} function on each side, and $\psi^{q-p} x = \alpha^r x$. Whence $\psi x = \alpha^{\frac{r}{q-p}} x$, and $\psi^{\frac{(q-p)n}{r}} x = \alpha^n x = x$. ψx is therefore a periodic of the order $(q-p) \cdot \frac{n}{r}$, the $q-p$ function having the particular form $\alpha^r x$. An arbitrary function will be comprehended in $\alpha^{\frac{r}{q-p}} x$, which will disappear in $\alpha^r x$.

The truth of this solution may be otherwise shown thus; take the ψ^p function on both sides, and change x into $\alpha^r x$, the proposed equation will become

$$\psi^{2p} \alpha^{2r} x = \psi^{p+q} \alpha^r x = \psi^q \psi^p \alpha^r x = \psi^{2q} x$$

Another similar process gives $\psi^{3p} \alpha^{3r} x = \psi^{3q} x$, and generally

$$\psi^{\frac{np}{r}} \alpha^n x = \psi^{\frac{nq}{r}} x, \text{ or } \psi^{\frac{np}{r}} x = \psi^{\frac{nq}{r}} x.$$

Whence $\psi^{\frac{n}{r}(q-p)} x = x$.

Mr. Babbage, to whom the world owes so much for his discoveries in this calculus, has given a different solution, when $r=1$. He finds by an indirect process that $\psi x = \phi^{-1} f \phi x$ will satisfy the conditions of the question when f is any periodic of the $q-p$ order, and ϕ any symmetrical function of $x, \alpha x, \alpha^2 x, \dots, \alpha^{n-1} x$; n, p, q being whole numbers. His solution comprehends the form of α not in the particular solution f , which is indeed left perfectly arbitrary, but in a certain limitation to the arbitrary function itself. This method likewise gives every value of $\psi^{\frac{q-p}{r}} x = x$ without any exception; but if my views are correct, $\psi^{\frac{q-p}{r}} x$ should have but one value, and that $= \alpha x$, and free from an arbitrary function.

I have some other observations to make on this subject and the nature of periodic functions, which brevity obliges me to defer to another opportunity: but I may here observe, that the functional theory properly considered, results from a much
more

more comprehensive system, which has led me to a direct and complete integration of equations of differences of all orders and degrees, and the numerical resolution of all algebraic equations. Indeed, I am not without hopes, from some ideas which have lately occurred to me, that it will likewise ultimately lead to the direct algebraic resolution of equations of all degrees; and if ever the thing is to be done to the complete integration of differential equations, or show us what cases can, and what can never, be integrated in finite terms.

J. HERAPATH.

Errata in my last paper: Phil. Mag. for September 1824:

P. 198, 12 lines from bottom for . read ,

— 8 insert "is" after Mr. Herschel's.

LVIII. *Statement on the part of the Monthly Critical Gazette respecting the Review of Sir J. E. SMITH'S English Flora in that Publication.* By A CORRESPONDENT.

To the Editors of the Philosophical Magaziné and Journal.

Gentlemen,

AS a reader from its origin, and a frequent correspondent of your valuable Magazine, and as one who has also read, and felt a warm interest in behalf of a new *Review* which started in June last, professing the novel and very useful design, of noticing every *British Publication*, at the beginning of that month, next but one after it first appears in the shop of a publisher; I have been induced, by the notice you have taken, in pages 226 and 227 of your September Number, of a critique in the first number of this Review, on the very able and important work of Sir James E. Smith, his "*English Flora*," to request your permission to state, that after having read Sir James's work, and since carefully compared your comments with its pages, I fully and most unequivocally concur in the justice and propriety of your comments; and the Editor of the *Monthly Critical Gazette* after having made a like comparison, commissions me to say the same for him; except that we could have wished the last paragraph, and particularly the four last lines, of your comment had been somewhat more guardedly expressed; and so, as not to have overlooked the new and distinguishing character of the Review in question, as standing pledged to notice *all the works* of science as well as on other subjects: because out of this pledge, under peculiar circumstances

which I am about to mention, has arisen the injustice to Sir James Smith which is now deplored.

Sir James Smith's two volumes were, with a few others, committed to the critical examination of a Gentleman who came highly recommended, himself a writer on Botany, and experienced, as the Editor was led to believe, in similar duties to those required of him in the present instance; which were, to furnish early (as the time of printing and the limits of the work required) "a condensed, *true and impartial account* of the subject, execution and character" of each of the works so submitted for examination; the proffered remuneration being unusually liberal, and fully adequate to the duties contracted to be performed. It happened however, in the hurry of getting up the first Number, and without the Editor's suspicion of any thing wrong being awakened thereby, that the critiques from the Gentleman alluded to (as well as some from others) came to hand so exceedingly late in the month of May, as unfortunately to occasion the neglect, on the part of the Editor, of revision of this review of Sir James's work.

It needs, I submit, gentlemen, but a small share of discernment in any reader of Sir James's work, and of the critique on the same, to discover, that private resentment on the part of the Critic has dictated most of his remarks; stimulated, perhaps, by Sir James having omitted to notice or quote his botanical work, which has been alluded to herein: although in a short paragraph, in the middle of page xxv of his very able and highly instructive Preface, Sir James has candidly and delicately stated *his reasons*, which to me appear conclusive ones, why such omission has been made, but without either naming the author or expressly indicating his work; towards neither of which has Sir James shown animosity, as far as I can discover, or the wish to injure either. Perhaps, also, a soreness has been felt that F.L.S. does not grace the critic's name; not, as I have been well assured, through any personal offence taken, or influence exercised, by the President of the Linnæan Society, but because of foul and unmerited abuse heaped on the memory of the great Swedish Naturalist, and *on his system* of arranging plants, such as had too much disgusted a large majority of attending Fellows, for them to allow of the calumniator becoming their companion.

I greatly lament with you, gentlemen, that the very best works of science and research are *rarely noticed in the Reviews*; from 10 to 15 and 20 years ago, this was far less the case than at present; scarcely a Number of the established Reviews then appeared without containing one or more excellent analyses

analyses of works of science or the useful arts; written, many of them, as my inquiries have in several instances enabled me to ascertain, by eminent Professors and known scientific characters: but of late years, since the overwhelming flood of novels and works of fiction on the fields of literature, of travels and voyages, and wordy disquisitions on political economy, and a few other subjects devoid of fixed principles; these have enabled the Reviews alluded to, to fill their periodical Numbers without calling in the aid of any scientific or practical men, and science and the useful arts have accordingly been almost entirely banished from their pages; volume after volume of these Reviews having appeared, without the notice of a single work of this kind; except, *perhaps*, that its title may have appeared in their monthly or quarterly list of new publications.

This state of things, so degrading and injurious to science and art, I saw no hopes of being removed, until the announcement of the *Monthly Critical Gazette*; which, although its notices must often be too short to answer fully the purposes desired, yet, if candidly and fairly done, as I understand to be the wish and determination of the Editor and Proprietors that they shall be, these notices cannot fail of being useful; and particularly, as I hope, in stimulating the other Reviews, having more ample space, to return to and even improve upon the good practices, from which they have departed, of giving full, able and early accounts of important works of science and research. I am, gentlemen, yours, &c.

London, Oct. 5. 1824.

A CONSTANT READER.

LIX. *Introduction to the Seventh Section of BESSEL'S
Astronomical Observations.*

[Continued from p. 261.]

7. *Summary of the Results obtained.*

FOR the purpose of giving a general view, I shall put together all the reductions which, agreeably to the investigations here communicated, are to be applied to the Königsburg observations with Reichenbach's circle, and by which the calculations are made in the journals since the beginning of 1822. To the readings of the circle for an observation made in the meridian, or reduced to the meridian, is added for flexure and imperfect division

$$+ 1''\cdot 11 \sin(u + 1^\circ 33') + 0''\cdot 26 \cos(u + 1^\circ 33') + \text{error of division,}$$

division, the latter being taken out of the table in article I. If two verniers only have been read off, the difference between two verniers and four is to be applied besides; by the curve which I have drawn, and the mean difference of the two pairs of verniers, which in the 6th section of this work was found $= 1''\cdot 26$, I have made a table of this difference, which, with the table of the corrections for flexure and imperfect division, is to be found at the end of this Introduction. To the places of the pole, derived from observations of the two pole stars, is to be added, in the Eastern position of the circle $-0''\cdot 25$

Western $+1''\cdot 18$

The polar distances thereby obtained are cleared from refraction by the formula

$$g \cdot 1,003282 \left(\frac{b}{333,28} \times \frac{5550+10}{5550+\tau'} \times \frac{53700+\tau'}{53700+10} \right)^A \left(\frac{180+16.75 \cdot 0,36438}{180+(f-32)0,36438} \right)^\lambda$$

where g, A, λ refer to the table in the *Fundamenta Astronomiæ*, and b signifies the true height of the barometer in Paris lines. τ' and f the readings of the interior centesimal and exterior Fahrenheit thermometer. For facilitating this computation I give below tables in which I have assumed for $g \cdot 1,003282$ the form $\alpha \text{ tang. zenith distance}$; they contain $\log. \alpha$ as far as zenith distance 80° : but I hope to continue it to the horizon as soon as Dr. Argelander's observations have been more accurately investigated.

It is probable in itself, that every observatory does not want a *peculiar* table of refraction, except perhaps for very small altitudes; and this is likewise now confirmed by the close agreement of my new determination with the former one. But it may be doubted whether the place where the exterior thermometer is fixed, does not give rise to a mean difference between the temperature which it shows and the real temperature of the air: in order to investigate this, I placed a second thermometer at the distance of six inches from the building, and perfectly exposed to the wind, which I have compared these six months with Schafirinsky's, which is attached at the same height to a side shutter of the observatory; but, to my great surprise, I have never perceived a sensible difference, and therefore I now believe that a difference of refraction in different observatories arising from this cause is not much to be feared.

Applying these refractions to the Königsburg observations, there remain irregularities, the amount of which I have determined in the 3d article, deducting the one taking place for the zenith, which is $0''\cdot 7126$, there will remain that probable error of a single observation at which one would arrive by the

the use of my refractions, if the observations were made and read off with absolute correctness. I find it as follows:

Z. D.	Z. D.
45° 0''·27	81° 1''·00
60 0·34	82 1·11
65 0·37	83 1·25
70 0·46	84 1·43
75 0·66	85 1·71
80 0·92	86 2·40

The errors originating in the dispersion of light, indistinctness of the stars, &c., are comprehended in these quantities; in the vicinity of the horizon these disturbing causes act so strongly that one might be inclined to ascribe to them only errors like those here given: I mention this as an additional proof of the necessity of employing the factor λ ; were it neglected, and yet the tables used in such different temperature as the winters and summers present at Königsburg, one would find much larger probable errors.

8. *Latitude of the Observatory.*

The latitude cleared from flexure, but still uncorrected for errors of division and refraction, is by art. 4, = $54^{\circ} 42' 50''\cdot785$; the errors of division in the eastern and western position of the circle have been above determined to be respectively = $+0''\cdot177$ and $+0''\cdot325$, from which follows the correction $-0''\cdot074$: the new determination of the refraction produces another correction of $-0''\cdot188$; so that the latitude resulting from all observations with the meridian circle is = $54^{\circ} 42' 50''\cdot52$.

Cary's circle formerly gave by zenith distances of α *Ursæ Minoris* (= 36°) measured on both sides of the meridian $54^{\circ} 42' 50''\cdot276 - 0''\cdot452\Delta\delta$, or putting the correction of the declination taken from the tables = $-0''\cdot339$, $54^{\circ} 42' 50''\cdot43$, from which is to be deducted for the new correction of refraction $0''\cdot19$. Between these two determinations there is therefore a difference of $0''\cdot28$, which is indeed a little beyond the limits of the probable error, but affords no sufficient reason for supposing that any constant error has been neglected. Which of the two determinations deserves the preference, I do not dare to decide, as I consider it to be exceedingly difficult to arrive at certainty with regard to such small quantities.

9. *Solstices of 1820 and 1821.*

The solstices having frequently given rise to doubts respecting the accuracy of the declinations, I think that I may insert here what my observations and the methods of reducing them here explained have brought out.

Summer Solstice of 1820.
Correction in longitude of Carlini's Solar Tables of the Sun's Solstice = -5'.8; 9 observations.

	Readings of Circle.	Corrections.	Apparent Declination.	Refraction.	Semi-diameter.	Parallax.	Reduction to Solstice.	Apparent Obliquity.
June 5	30 49 27.4	+1.14	22 19 12.47	- 35.88	+15 47.04	+4.53	+53 25.19	23 27 53.35
7	30 5 32.9	+1.13	23 3 6.98	- 34.77	-15 46.82	+4.50	+41 3.56	53.45
11	30 17 7.7	+1.13	22 51 32.18	- 35.36	+15 46.43	+4.46	+21 8.78	56.49
15	327 19 25.9	-0.32	23 36 26.28	- 34.34	-15 46.12	+4.43	+7 44.70	54.97.:
21	327 27 8.4	-0.32	23 44 8.78	- 33.98	-15 45.74	+4.41	+0 0.07	53.53
22	326 55 30.1	-0.31	23 12 30.49	- 34.42	+15 45.69	+4.41	+0 9.43	55.60
23	327 26 22.6	-0.32	23 43 22.98	- 34.00	-15 45.65	+4.41	+0 43.54	51.28
24	326 53 57.3	-0.31	23 10 57.69	- 34.61	+15 45.61	+4.41	+1 42.39	55.49
25	327 24 2.3	-0.32	23 41 2.68	- 34.24	-15 45.58	+4.42	+3 5.91	53.19
27	326 48 30.6	-0.30	23 5 31.00	- 34.63	+15 45.54	+4.42	+7 6.98	53.31

Mean . . . 23 27 53.96.:

Winter Solstice of 1820.

Correction in longitude of Carlini's Solar Tables = -4'.9; 10 observations.

	Readings of Circle.	Corrections.	Apparent Declination.	Refraction.	Semi-diameter.	Parallax.	Reduction to Solstice.	Apparent Obliquity.
Dec. 6	75 52 46.1	+1.29	-22 44 15.53	-4 33.55	+16 16.20	+8.59	-58 28.98	23 27 53.27.:
8	75 33 48.3	+1.29	-22 25 17.73	-4 19.23	-16 16.43	+8.60	-42 8.14	52.93
15	76 37 15.4	+1.29	-23 28 44.83	-4 49.81	+16 17.12	+8.63	-9 43.07	51.90
16	76 8 39.8	+1.29	-23 0 9.23	-4 40.17	-16 17.20	+8.63	-6 56.05	54.92
17	280 8 4.3	-1.20	-23 34 48.73	-4 55.87	+16 17.28	+8.63	-4 37.07	55.76
18	280 38 34.1	-1.20	-23 4 18.93	-4 44.06	-16 17.55	+8.63	-2 46.20	57.91.:
19	280 5 7.7	-1.20	-23 37 45.33	-5 6.21	+16 17.41	+8.63	-1 23.52	49.02.:
20	280 26 28.3	-1.20	-23 6 24.73	-4 50.49	-16 17.47	+8.63	-0 29.03	53.09
22	280 3 39.3	-1.20	-23 39 13.73	-5 1.71	+16 17.57	+8.63	-0 4.91	54.15

	Readings of Circle.	Corrections.	Apparent Declination.	Refraction.	Semi-diameter.	Parallax.	Reduction to Solstice.	Apparent Obliquity.
Dec. 23	280 36' 32".4	-1".20	23 6' 20".63	-4' 48".81	-16' 17".61	+8".64	- 0' 35".28	23 27' 53".49
24	280 5 10.0	-1".20	23 37 43.03	-5 23.52	+16 17.65	+8".64	- 1 33.96	54.22
25	280 38 59.0	-1".20	23 3 54.03	-4 48.37	-16 17.68	+8".64	- 3 0.92	52.36
31	76 26 16.0	+1".29	23 17 48.19	-4 58.03	+16 17.78	+8".63	-21 34.31	54.22.:
Jan. 3	76 38 36.9	+1".29	23 30 9.09	-4 27.86	-16 17.75	+8".62	-37 7.27	53.35
						Mean . .		23 27 53.53
<i>Summer Solstice of 1821.</i>								
Correction in longitude of Carlini's Solar Tables = -7".6; 9 observations.								
June 12	326 38 34.5	-0".30	22 54 29.85	- 35.28	+15 46.37	+4.45	+18 7.53	23 27 52.92
14	327 16 57.8	-0".32	23 32 53.13	- 34.80	-15 46.21	+4.43	+11 13.84	50.39
16	326 50 43.0	-0".31	23 6 38.34	- 35.40	+15 46.07	+4.42	+ 5 58.23	51.64
17	327 24 15.4	-0".32	23 40 10.73	- 34.55	-15 46.00	+4.42	+ 3 57.37	51.97
18	326 54 17.6	-0".31	23 10 14.26	- 34.76	+15 45.93	+4.42	+ 2 21.21	51.06
19	327 27 0.8	-0".32	23 42 57.45	- 34.59	-15 45.86	+4.41	+ 1 9.88	51.26
26	30 1 32.5	+1".13	23 8 10.47	- 34.66	+15 45.56	+4.42	+ 4 24.69	50.45
27	29 32 5.8	+1".12	23 37 37.18	- 34.65	-15 45.54	+4.42	+ 6 31.64	53.05
28	30 6 8.1	+1".13	23 3 34.88	- 35.44	+15 45.53	+4.43	+ 9 3.23	52.63
29	29 37 34.9	+1".12	23 32 8.08	- 34.29	-15 45.52	+4.44	+11 59.47	52.18
July 3	326 28 51.9	-0".29	22 44 49.03	- 35.38	+15 45.50	+4.47	+27 48.51	52.13
						Mean . .		23 27 51.79

Winter Solstice of 1821.

Correction in longitude of Carlini's Solar Tables = -5'.7; 7 observations.

	Readings of Circles.	Corrections.	Apparent Declination.	Refraction.	Semi-diameter.	Parallax.	Reduction to Solstice.	Apparent Obliquity.
Dec. 7	75 59 23.8	+1.29	-22 49 37.81	-4 29.46	+16 16.29	+8.60	-50 13.50	23 27 35.86
8	75 33 33.7	+1.29	-22 23 47.71	-4 20.26	-16 16.40	+8.60	-43 40.28	56.05
12	280 26 22.9	-1.20	-23 17 45.38	-4 35.67	+16 16.83	+8.62	-21 56.99	52.60
16	280 44 31.0	-1.20	-22 59 37.28	-4 31.80	-16 17.18	+8.63	7 33.72	51.35
17	280 9 40.3	-1.20	-23 34 27.98	-4 42.44	+16 17.26	+8.63	4 7.69	52.22
18	280 40 4.3	-1.20	-23 4 3.98	-4 30.25	-16 17.33	+8.63	3 9.79	52.73
26	280 8 44.5	-1.20	-23 35 23.78	-4 30.76	+16 17.70	+8.64	4 25.94	54.14
30	280 53 4.9	-1.20	-22 51 3.38	-4 18.67	-16 17.78	+8.63	-16 22.67	53.87
Jan. 3	280 40 4.4	-1.20	-23 4 3.88	-4 30.01	+16 17.75	+8.62	-35 44.78	52.30
8	281 46 48.0	-1.19	-21 57 20.27	-4 14.16	-16 17.63	+8.60	-70 8.43	51.89
9	281 22 33.3	-1.19	-22 21 34.97	-4 23.93	+16 17.59	+8.59	-78 29.71	53.43

Mean Mean
 With the exclusion of the two first observations, which greatly differ from the others
 We have, therefore, from these four solstices:

	Apparent Obliquity.	Mean Obliquity.	Mean Obliquity 1820.
1820. Summer	23° 27' 53".96	23° 27' 45".66	23° 27' 45".88
Winter	53.53	45.42	45.87
1821. Summer	51.79	44.11	44.78
Winter	52.72	45.71	46.62

10. *Declinations of the fundamental Stars.*

In this observatory two series of observations for the declination of the fundamental stars have been made, the one with Cary's, the other with Reichenbach's circle. The former instrument, which is smaller, less accurately divided, and furnished with a less powerful telescope, gives observations less agreeing among themselves, and liable to greater errors of division; but the repeated examinations guard against constant errors, and the contingent ones may be estimated agreeably to the laws of probability. There is, consequently, no reason why the first should not appear by the side of the latter, notwithstanding the much greater accuracy which the second one possesses.

I have suggested, therefore, to Messrs. Rosenberger and Scherck, two much esteemed disciples of mine, to reduce to the year 1815 all observations of the fundamental stars made with Cary's circle, applying the quantities for aberration and nutation now in use. They have used for this purpose the refractions which have been given to the observations in the journals, and have brought out by a very careful computation the following results:

	Zenith Distances for 1815.			
	East.	No.	West.	No.
α Aurigæ	8 55 3"91	26	5"45	20
	79 29 23.22	6	25.44	9
α Cygni	10 5 24.81	11	25.76	13
	80 39 43.05	7	40.26	6
α Lyrae	16 5 44.25	17	48.81	22
α Geminorum	22 25 57.35	20	54.50	25
β —	26 15 5.73	22	7.04	24
β Tauri	26 16 27.71	15	33.31	15
α Andromedæ	26 38 46.55	17	48.00	17
α Coronæ	27 22 15.25	17	16.48	17
α Arietis	32 7 51.83	7	56.94	11
α Bootis	34 33 50.29	24	48.83	16
β Tauri	38 35 12.18	16	14.08	12
β Leonis	39 6 28.92	8	29.80	12
α Herculis	40 6 14.21	1	20.55	5
α Pegasi	40 30 5.74	11	10.95	14
γ —	40 33 36.04	24	38.52	21
α Leonis	41 50 51.30	21	49.91	17
α Ophiuchi	42 0 38.77	15	40.82	14
γ Aquilæ	44 32 37.08	17	38.53	17

X x 2

α Aquilæ

	Zenith Distances for 1815.			
	East.	No.	West.	No.
α Aquilæ	46 19 33.42	27	36.90	29
α Orionis	47 21 6.35	18	3.29	13
α Serpentis	47 41 56.77	17	56.59	12
β Aquilæ	48 45 38.71	22	42.63	24
α Canis Min.	49 1 26.51	23	27.45	24
α Ceti	51 21 26.97	3	26.84	6
β Virginis	51 54 26.91	13	26.86	13
α Aquarii	55 55 39.17	3	38.66	6
α Hydræ	62 34 33.37	6	35.61	8
β Orionis	63 8 17.27	8	17.68	9
α Virginis	64 54 21.99	40	25.25	32
1 α Capric.	67 47 10.48	10	10.33	14
2 α —	67 49 30.74	7	28.89	3
1 α Libræ	69 56 0.48	3	7.05	2
2 α —	69 58 48.42	6	48.70	2
α Canis Maj.	71 11 4.33	38	4.17	41
α Scorpii	80 43 29.29	11	26.38	5
α Pisc. austr.	85 18 49.35	6	52.52	11

The number of observations of α *Herculis*, 1 α and 2 α *Libræ* is very small, and on that account I have requested Dr. Argelander to observe repeatedly those stars; the results were:

α <i>Herculis</i>	40° 6' 15".76	12	19".79	12
1 α <i>Libræ</i>	69 56 3.96	4	6.36	4
2 α —	69 58 46.45	4	48.33	3

If these new observations are joined to the former ones, the numbers of the table are changed into the following:

α <i>Herculis</i>	40° 6' 15".64	13	20".01	17
1 α <i>Libræ</i>	69 56 2.46	7	6.59	6
2 α —	69 58 47.63	10	48.48	5

For these calculations the errors of division of the instrument have been taken from the table calculated from the formula for this error, published in the 1st section of this work, viz. $-2''.446 + 0''.654 \sin 2z - 6''.843 \cos 2z$.

The more perfect expression for the errors of division is, however,

$$-2''.724 + 0''.654 \sin 2z - 6''.843 \cos 2z - 0''.258 \sin 4z + 0''.278 \cos 4z$$

and the analogous one found by a new examination after four years use of the instrument,

$$-3''.000 + 0''.893 \sin 2z - 6''.741 \cos 2z - 0''.172 \sin 4z + 0''.452 \cos 4z. \quad \text{Both}$$

Both determinations possessing nearly equal accuracy, the mean of both is to be applied, and the difference of this mean from the formula by which the table has been calculated, is to be added; hence the following correction:

$$\mp 0''\cdot416 + 0''\cdot120 \sin 2z \pm 0''\cdot050 \cos 2z - 0''\cdot215 \sin 4z \\ \pm 0''\cdot365 \cos 4z,$$

where the upper signs are to be taken when the lower microscope A gives zenith distances, the lower one when it gives altitudes.

It is moreover necessary to allow for the correction of refraction found in article 7, and lastly to convert the zenith distances into declinations, for which purpose I have adopted the latitude $54^{\circ} 42' 50''\cdot52$. In this manner the following results have been obtained:

	Corrections.				Declinations 1815.	
	East.		West.		East.	West.
	Division.	Refract.	Division.	Refract.		
α Aurigæ	-0'01	+0'05	-0'16	+0'05	45 47 46'57	45'18
}	-0'01	+2'00	+0'38	+1'95	44 37 25'66	41'74
	0'00	+0'05	-0'19	+0'05	25'97	24'90
α Cygni	-0'01	+0'47	+0'34	+0'04	28 26 22'40	28'84
α Lyrae	+0'09	+0'09	-0'34	+0'09	38 37 6'09	1'96
α Geminorum	+0'25	+0'07	-0'50	+0'08	32 16 52'85	56'44
β —	+0'36	+0'11	-0'59	+0'13	28 27 44'32	43'96
β Tauri	+0'36	+0'05	-0'59	+0'02	28 26 22'40	17'78
α Andromedæ	+0'38	+0'08	-0'60	+0'07	28 4 3'51	3'05
α Coronæ	+0'41	+0'14	-0'61	+0'15	27 20 34'72	34'50
α Arietis	+0'56	+0'06	-0'68	+0'05	22 34 58'17	54'21
α Bootis	+0'64	+0'21	-0'70	+0'23	20 8 59'38	62'16
α Tauri	+0'76	+0'09	-0'71	+0'07	16 7 37'39	37'08
β Leonis	+0'77	+0'20	-0'71	+0'22	15 36 20'63	21'21
α Herculis	+0'80	+0'16	-0'70	+0'14	14 36 33'92	31'07
α Pegasi	+0'81	+0'21	-0'70	+0'19	14 12 43'76	40'08
γ —	+0'81	+0'16	-0'70	+0'16	14 9 13'51	12'54
α Leonis	+0'83	+0'15	-0'69	+0'10	12 51 58'24	61'20
α Ophiuchi	+0'84	+0'29	-0'69	+0'28	12 42 10'62	10'11
α Aquilæ	+0'89	+0'32	-0'67	+0'32	10 10 12'23	12'34
α —	+0'92	+0'34	-0'64	+0'31	8 23 15'85	13'95
α Orionis	+0'93	+0'29	-0'62	+0'29	7 21 42'95	47'56
α Serpentis	+0'94	+0'28	-0'62	+0'29	7 0 52'53	54'26
β Aquilæ	+0'95	+0'37	-0'60	+0'37	5 57 10'49	8'12
α Canis Min.	+0'95	+0'22	-0'59	+0'25	5 41 22'84	23'41
α Ceti	+0'96	+0'06	-0'55	+0'03	3 21 22'53	24'20
β Virginis	+0'97	+0'24	-0'53	+0'19	2 48 22'40	24'00
β Aquarii	+0'96	+0'36	-0'44	+0'41	- 1 12 49'97	48'11
α Hydræ	+0'86	+0'08	-0'27	+0'12	- 7 51 43'79	44'94
β Orionis	+0'86	+0'26	-0'26	+0'00	- 8 25 27'87	26'90
α Virginis	+0'82	+0'47	-0'21	+0'49	-10 11 32'76	35'01
1 α Capric.	+0'74	+0'75	-0'14	+0'73	-13 4 21'45	20'40
2 α —	+0'74	+0'80	-0'14	+0'82	-13 6 41'76	39'05
1 α Libræ	+0'68	+0'34	-0'10	+0'39	-15 13 12'96	16'36
2 α —	+0'68	+0'31	-0'10	+0'38	-15 15 58'10	58'24
α Canis Maj.	+0'64	+0'71	-0'08	+0'63	-16 28 15'16	14'20
α Scorpii	+0'34	+1'56	-0'01	+1'42	-26 0 40'67	37'27
α Pisc. austr.	+0'18	+2'20	-0'05	+4'11	-30 36 1'21	4'06

[To be continued.]

LX. *On finding the exact Mean Solar Time.* By M. SMITH, Esq.

To the Editors of the *Philosophical Magazine and Journal.*

Gentlemen,

IN reply to a letter published in your last Number (p. 210), I beg leave to inform your correspondent Mr. Cooper, that in computing the hour of the day from the proposed data, viz. the latitude of the place, the sun's declination and altitude; he must invariably use the *visible* latitude, or that deduced immediately from observation; the reduced latitude being nothing more than a fiction invented for the purpose of facilitating the computation of solar eclipses, or other occultations of the heavenly bodies by the moon.

I have carefully examined the calculation your correspondent has made, and find it perfectly correct, except the line marked with an asterisk, which is unnecessary; the effect of this proportion would be to allow *twice* for the variation of the equation of time between noon and the instant of observation, which variation ought to be taken only *once* into the account, as is done by correcting this equation to the instant of observation. The latter part of the computation ought, therefore, to stand thus:

Apparent solar time	3 ^h 26 ^m 14 ^s ·9
Equation of time corrected to that instant	1 47·9

Mean solar time	3 28 2·8

The right ascension of the sun and stars as given in the Nautical Almanack, is expressed in *sidereal* time.

In using Dr. Tiarks's tables, the equation of time need not be considered at all; the reason of which is, that the interval between the sun and the star passing the meridian is given in mean solar time, which is not subject to any inequality. It must be observed, however, that to apply these tables to the year 1825, table I. must be corrected, by adding 2' 59" in the months of January and February, and subtracting 57" during the remainder of the year; the right ascensions of the stars in table III. require also to be augmented by their annual variation. I remain, gentlemen,

Your most obedient servant,

October 13, 1824.

M. SMITH.

LXI. *On finding the Latitude by the Altitudes of two Stars.*
By M. SMITH, Esq.

To the Editors of the Philosophical Magazine and Journal.

Gentlemen,

I SEND you the following very simple and accurate method of determining the latitude of any place in the northern hemispheres, by the altitudes of the two stars *Aliath* (or ϵ *Ursæ Majoris*) and γ *Cassiopeiæ*, taken at the same instant, without the hour of the night or any other data being required. The rule supposes the two stars to differ exactly twelve hours in right ascension; it will therefore be rigorously correct in the year 1831, and will not produce an error of a mile in the latitude for at least ten years before and after that period. The altitudes used must of course be the true altitudes of the stars, or those corrected for refraction and the dip of the horizon, and five places of decimals in the logarithms will be sufficiently accurate. I need not trouble you with the demonstration of the rule, as it is precisely analogous to that of reducing the lunar distance, and will therefore be understood by every astronomer.

The altitudes of the Stars Aliath and γ Cassiopeiæ given, to find the latitude of the place of observation:—

Rule.—Add together the two zenith distances and the constant arc $63^{\circ} 20'$; take half the sum, from which subtract the zenith distance of *Aliath* and the constant arc $63^{\circ} 20'$, noting the remainders.

Add together the sines of the two remainders, and the logarithm in the following table; take half the sum of these three logarithms, from which subtract the sine of half the difference between the declination and altitude of *Aliath*; the remainder is the tangent of an arc; the sine of this arc subtracted from the said half sum of the logarithms, leaves the sine of half the required co-latitude.

Table.

Years.			Logarithm.	Decl. <i>Aliath</i> .
1823	1824	1825	19.78592	$56^{\circ} 55'$
1826	1827	1828	19.78612	56 54
1829	1830	1831	19.78631	56 53
1832	1833	1834	19.78650	56 52
1835	1836	1837	19.78670	56 51
1838	1839	1840	19.78689	56 50
1841	1842	1843	19.78708	56 49
1844	1845	1846	19.78728	56 48

Example.

Example 1.

Given.	The altitude of Aliath.....		= 53° 25'
	The altitude of γ Cassiopeiæ		= 32 41
Required.	The latitude of the place.		
Zen. dist. of Aliath.....	36° 35'	Decl. Aliath...	= 56° 55
Zen. dist. of Cassiopeiæ	57 19	Alt. Aliath ...	= 53 25
Constant arc	63 20		2) 3 30
	<u>2)157 14</u>	Half difference =	<u>1 45</u>
Half sum	<u>78 37</u>		
First remainder	42 2	sine	= 9·82579
Second remainder	15 17	sine	= 9·42093
Log. in table			= 19·78592
			<u>2)39·03264</u>
Half sum of the three logarithms			19·51632
Half diff. decl. and alt. of Aliath	1° 45'	sine	8·48485
Tangent of an arc	84° 41'		<u>= 11·03147</u>
Half sum of the three logarithms			= 19·51632
Sine of the above arc.....	84° 41'		<u>= 9·99813</u>
Sine of half co-latitude	19° 15		<u>= 9·51819</u>
			<u>2</u>
	Co-latitude ...		<u>38 30</u>
	Latitude.....		<u>51 30 north.</u>

Example 2.

Given. The altitude of Aliath..... 42° 20'
 The altitude of γ Cassiopeiæ 57 48
 Required. The latitude of the place.

Answer. Latitude 63° 42' north.

Note.—The constant arc 63° 20', is the distance between the two stars, and the logarithm in the table is the sum of the log. cosecant of that arc, and the log. cosine of the declination of Aliath.

It may be necessary to add, that the star Aliath is the first star in the tail of the Great Bear; and that γ Cassiopeiæ is the centre star of five bright ones in that constellation, arranged in the form of the letter W. Their right ascensions and declinations for 1825, are as follows:

Aliath.....	R 12 ^h 46 ^m 17 ^s	Decl. 56° 54' 42" N.
γ Cassiopeiæ	R 0 46 12	Decl. 59 46 3 N.

I remain, gentlemen,

Your most obedient servant,

Nov. 9, 1824.

M. SMITH.

P.S.

P.S.—An answer to Mr. Samuel Cooper's questions on the subject of mean solar time, having appeared in your last Number, I beg leave to observe, that your correspondent "Glosterian" is mistaken in the only instance in which he has given a direct answer to Mr. Cooper's queries. The sun's right ascension, as given in the Nautical Almanack, is expressed in *sidereal time*, not in solar time. To prove this, it will suffice to observe, that at the instant of the sun entering *Libra*, his right ascension in the Nautical Almanack is 12 hours; whereas, had it been expressed in solar time, it would be only 11^h 58^m 2^s; the entire circle of the ecliptic passing the meridian in 24 hours sidereal time, which is equal to 23^h 56^m 4^s solar time.

LXII. *Analyses of a Series of Papers on the Structure, Distribution, and Functions of the Nerves; by CHARLES BELL, Esq.; which have appeared in some late Volumes of the Philosophical Transactions.*

[Continued from p. 128.]

MR. BELL in pursuing the anatomy of those parts of the animal frame, which more immediately and distinctly exhibit the truth of the hypotheses with which he set out respecting the necessity of our viewing the nervous system, as divided into two grand classes; the one regulating and controlling the respiratory apparatus, and associating the actions of other parts therewith; the other proving the source of voluntary motion, and of sensibility; has endeavoured to illustrate that hypothesis still further, by the facts and observations which are furnished by the anatomy and physiology of the eye in particular.

The difficulties which must have presented themselves in making this attempt are, from the very compound nature and functions of this most beautiful organ, such as would be sufficient to deter most persons from seeking for illustration from it on any point; and it cannot but be regarded as an additional corroboration of the truth of this theory, when such a complicated system is seen to bear testimony to it in all its parts.

On the Motions of the Eye in illustration of the Uses of the Muscles and Nerves of the Orbit.—(Phil. Trans. 1823.)

The plan which Mr. Bell has adopted in order to confirm his doctrine of the nervous system by the anatomy and physiology of the eye is, *first*, to show the uses of the apparatus of frame-work, which is exterior to the eyeball; and then, in the

second place, to consider how the nerves minister to these offices: whilst the object itself of his paper is to explain the reason of there being six nerves distributed to the eye, and consequently crowded into the narrow space of the orbit.

Mr. Bell has deemed it necessary to enter into a minute description of the relative functions of the different muscles and parts which are around the eye-ball, and which constitute its frame-work: this description, however, is of such a nature, that to do it justice, and convey to the reader a proper idea of the opinions which the author entertains, the whole of the first part ought to be brought forward *verbatim*; but inasmuch as the second part, though depending a good deal on the first, bears more directly upon his hypothesis of there being distinct functions performed by distinct nerves, we venture to proceed to the confirmations which it contains of the hypothesis itself, after giving a general view only of the first part, more especially as these confirmations will also tend to make our readers better acquainted with the more important points treated of in the first part. What these points are, may appear from the remarks with which Mr. Bell commences the first part of the subject.

“Even grave and learned men,” he says, “have eulogized this organ (of vision) as the most necessary to intellectual enjoyment, and which ranges from the observation of the fixed stars to that of the expression in the human face. But this admiration is in part misplaced, if given to the optic nerve and ball of the eye exclusively; since these high endowments belong to the exercise of the whole eye, to its exterior apparatus as much as to that nerve which is sensible to the impressions of light. It is to the muscular apparatus, and to the conclusions we are enabled to draw from the consciousness of muscular effort, that we owe that geometrical sense, by which we become acquainted with the form, and magnitude, and distance of objects. We might as well expect to understand the uses of a theodolite, or any complicated instrument for observations, by estimating the optical powers of the glasses, without considering the quadrant, level, or plumb-line, as expect to learn the whole powers of the eye by confining our study to the naked ball. I propose to show, that we must distinguish the motions of the eye, according to their objects or uses, whether for the direct purpose of vision, or for the preservation of the organ: that the eye undergoes a revolving motion not hitherto noticed; that it is subject to a state of rest and activity, and that the different conditions of the retina are accompanied by appropriate conditions of the surrounding muscles; that these muscles are to be distinguished into two natural classes; and that

that in sleep, faintness, and insensibility, the eye-ball is given up to the one, and in watchfulness, and the full exercise of the organ, it is given up to the influence of the other class of muscles: and finally, that the consideration of these natural conditions of the eye explains its changes as symptomatic of disease, or as expressive of passion."

This first part, therefore, is taken up by a number of experiments and observations which confirm these views, and afford the author secure ground for establishing an arrangement of the nerves of the eye, whilst they at the same time enable him to distinguish them according to their uses.

The recti and obliqui form the two natural classes of muscles attached to the eye-ball; the four recti are strictly voluntary, and the two obliqui are involuntary: hence, according to the author's experiments upon the eye of the monkey, the division of the latter does not in any degree affect the voluntary motions which direct the eye to objects. This cannot, however, be said of the involuntary winking motions of the eyes; in those, in winking to avoid injury, the oblique muscles are in operation, as likewise in that peculiar and invariable elevation of the cornea, which takes place during sleep, or when the eye-lids are closed. The same experiments and observations have moreover led the author to conclude, that whilst the control and direction of the eye to objects belong entirely to the voluntary or recti muscles, the preservation of the organ itself, either by withdrawing the surface from injury, or by the removal of what is offensive to it, belongs, more especially, to the two obliqui.

In illustration of the necessity and importance of this classification of the muscles of the eye, we wish to bring forward some of the author's remarks upon *the expression of the eye, and of the actions of its involuntary or oblique muscles in disease.*

"If, as I have alledged, the uses of the oblique muscles of the eye have been misunderstood, and if, as I hope presently to prove, the distinctions of the nerves have been neglected, the symptoms of disease, and the sources of expression in the eye, must remain to be explained.

"During sleep, in oppression of the brain, in faintness, in debility after fever, in hydrocephalus, and on the approach of death, the pupils of the eyes are elevated. If we open the eye-lids of a person during sleep or insensibility, the pupils will be found elevated. Whatever be the cause of this, it will be found that it is also the cause of the expression in sickness, and pain, and exhaustion, whether of body or mind: for then the eye-lids are relaxed and fallen, and the pupils ele-

vated so as to be half covered by the upper eye-lid. This condition of the eye during its insensible unexercised state, we are required to explain.

“It is a fact familiar to pathologists, that when debility arises from affection of the brain, the influence is greatest on those muscles which are, in their natural condition, most under the command of the will. We may perceive this in the progressive stages of debility in the drunkard, when successively the muscles of the tongue, the eyes, the face, the limbs, become unmanageable; and, under the same circumstances, the muscles which have a double office, as those of the chest, lose their voluntary motions, and retain their involuntary motions, the force of the arms is gone long before the action of breathing is affected.

“If we transfer this principle, and apply it to the muscles of the eye, we shall have an easy solution of the phenomena above enumerated. The recti are voluntary muscles, and they suffer debility before the oblique muscles are touched by the same condition; and the oblique muscles prevailing, roll the eye.

“If it be further asked, why does the eye roll upwards and inwards? we have to recollect, that this is the natural condition of the eye, its position when the eye-lids are shut, and the light excluded, and the recti at rest, and the obliqui balanced.”

The circumstance of there being only nine nerves properly enumerated as proceeding from the brain, and six of these distributing themselves to the eye; since the second, third, fourth, fifth, sixth and seventh, go into the orbit, and, as the author expresses it, may be said to be concentrated into a space no larger than a nut-shell; affords an opportunity of demonstrating the existence of a correspondence between the compound functions of an organ, and the nerves transmitted to it, according to what was stated hypothetically in the first part of the paper.

But it cannot be expected, in the investigation of a subject rendered so difficult by reason of the number and complexity of the nerves transmitted to a small organ like the eye, that it is always possible to give demonstrative evidence, or to answer opposition by means of experiments; and here the author is obliged to trust more to reasoning, and to a minute attention to the anatomy, than to experiment.

Of the Function of the Ophthalmic Branch of the fifth Nerve.

We are, in the first place, to inquire by what nerve the common endowment of sensibility is bestowed upon the membranes and surfaces of the eye. On recurring to this subject,

we are reminded, that the sensibilities of the body differ as much in kind as in degree; that the sensation of pain is provided to rouse our activity, and guard us against violence, or, by means more direct, to excite instinctive motions, which shall anticipate the most rapid actions of the will, and serve as a more perfect safeguard. The trigeminus, or fifth nerve, bestows upon all the surfaces of the head and face, external and internal, that sensibility which is enjoyed by the rest of the body through the spinal nerves. But through some of its branches is also bestowed that distinct sense on certain parts for the purpose of drawing the muscles into combination; as, for example, that fine sensibility of the surface of the eye to the presence of minute particles, which at once excites the flow of tears, and draws the muscles into a combination to expel the offensive matter.

It has been shown in a former paper, that the division of a branch of the fifth nerve distributed to the cheek and lips, deprived these parts of their sensibility, although they remained in possession of other nerves, and continued to enjoy muscular activity. The same has been proved in regard to this ophthalmic branch; if that branch of it which comes through the orbit and mounts upon the forehead, be divided, the skin will be deprived of its sensibility. Whence it is allowable to infer, that this is the case with the ophthalmic branch of the same nerve also; but not to rest upon inference alone, the symptoms of disease both render deep dissection in the living animal unnecessary, and authorise the conclusion; for a case was communicated to the author by Mr. Crampton, of Dublin, which he has adduced in part, and which appears to justify the inference sufficiently.

“A few days after the discharge from the ear had ceased, the eye became entirely insensible to the touch. This loss of feeling extended to the lining of the eye-lids, to the skin covering them, and to the skin of the cheek and forehead, for about an inch surrounding the eye: it did not go beyond the middle line of the face. When she told me her eye was *dead* (as she expressed it), to be certain, I drew my finger over its surface; and so far was this from giving her pain, that she assured me she could not feel that I was touching it at all. The eye-lids made no effort to close while I was doing this, but the conjunctiva appeared sensible to the stimulus, as a number of vessels on the surface of the eye became immediately injected with blood.” It is only necessary to remark, in order to understand the inference, that the ophthalmic nerve in question goes through the orbit, supplying the parts that are contained in it, and extends its branches to the angle
of

of the eye, eye-lids, and forehead: hence it is allowable to attribute the insensibility of the surfaces of the eye, as well as of the skin around the eye, to the affection of the same nerve near its root.

The author, moreover, has never been able to excite the motion of the eye by irritating the ophthalmic branch of the fifth after the division of its root, because no sensation was conveyed to the sensorium; and consequently, no mandate transmitted from it for exciting the action of those muscles whose office it is to move the eye on the presence of any foreign body upon it. The young lady, in the case just described, could see, and could move the eye and eye-lids; the eye itself was irritated by touch, as appeared from the rising inflammation; but by the insensibility of the ophthalmic nerve, a link was lost in the relation necessary to join the action of the muscles to the sensibility of the surface.

Of the Nerves performing the involuntary Motions.

Although nerves are found in great profusion to come out upon the eye-lids and forehead; yet they do not, as has been supposed, direct the motions of these parts; this is effected by means of a very small branch of the respiratory nerve of the face, which comes out before the ear, and is designated the *portio dura* of the seventh pair. The division of this branch is followed by a loss of the motions of the eye-lids, and they remain open; hence the eye being unguarded and unwashed, it becomes dry by evaporation, and inflames, and the cornea becomes opaque. To be satisfied of the existence of certain relations and of the connexions of remote parts in the animal frame, it is only necessary to attend to the explanation of them as given by the author himself.

“ During the state of excitement of the respiratory organs, a very extensive consent of the muscular frame is necessary to bind together and support the textures, that they may bear the strain, either during violent efforts of the body, or in coughing, sneezing, &c. We may take the act of sneezing, as a familiar example of the manner in which the eye is guarded during a sudden and violent act of expiration.

“ At the instant of this convulsive action of the respiratory muscles, a violent impulse is communicated to the head along the column of blood in the vessels of the head and neck. Everybody is sensible of the eye flashing light, but the cause is mistaken; for it is supposed to be the impulse of blood forced into the eye; whereas it is the contraction of the eye-lids to counteract the force of the impulse, and to guard the delicate texture of the eye. If the eyelids be held open during

ring the act of sneezing, no sensation of light will be experienced, because the contraction of the eye-lids upon the eye-ball is prevented."

The author proceeds to question the accidental nature of this connexion between the action of the respiratory muscles, and that of the eye-lids; and then considers it rather as a provision to compress and support the vascular system of the eye, and thus to guard it against the violent rush of blood which attends certain acts of respiration. This would appear to be confirmed, by the circumstance of the conjunctiva of a child suddenly filling with blood, and the eye-lid everting, on our opening its eye-lids whilst crying and struggling with passion, at which time the natural support of the eye is taken off.

The two offices performed by the respiratory nerve of the face, or *portio dura* of the seventh, one of which is voluntary, as in moving the cheeks and lips in speech; and the other involuntary, as in moving the nostrils in breathing during sleep or insensibility; are in like manner manifested in that branch of the respiratory nerve which is prolonged to the eye-lids; inasmuch as to this is owing, the contracting of the eye-lids by volition, and their involuntary winking motions, which are for dispersing the tears, and preserving the lucid surface clear: still the author is inclined to think that there are distinct filaments bound up together, which produce these distinct offices or functions; but such a circumstance cannot be demonstrated except in the spinal nerves, where the roots are separate.

[To be continued.]

LXIII. *Apparent Right Ascension and Declination of the four Minor Planets, at and about their ensuing Opposition.*

	Opposition.		Anomaly.	Dist. from the Earth.
Vesta	1825. Feb. 28th	9 ^h	91° 1'	1·357 Rad. ☉
Pallas	Mar. 13th	7	232 2	1·280
Ceres	Mar. 14th	9	207 16	1·603
Juno	June 23d	8	38 16	2·143

PALLAS being in the inferior part of its orbit, and 52° from its perihelion, will probably appear as a star of 8th magnitude. Juno will be too near its aphelion, in the superior part of its orbit, to be visible with any illumination of the wires; but the daily change in declination being small, the planet's transit may be compared with fixed stars.

Blackheath, Nov. 2, 1824.

S. GROOMBRIDGE.

Vesta.

360 *Ascension and Declination of the four minor Planets*

VESTA.				PALLAS.						
1825.	R			Dec. N.	1825.	R			Dec. S.	
at 12 ^h	h	'	''	°	'	''	°	'		
Feb. 6	11	19	26	14	14	11	48	55	5	44
7		18	51		22	19	48	27		23
8		18	15		30½	20	47	58		1½
9		17	38		39	21	47	29	4	39½
10		17	1		47½	22	46	59		17
11		16	24		56	23	46	28	3	54½
12		15	46	15	4½	24	45	56		42
13		15	6		13	25	45	23		9½
14		14	24		22	26	44	49	2	46½
15		13	40		30½	27	44	14		23
16		12	54		39½	28	43	37	1	59
17		12	6		48	Mar. 1	42	59		35
18		11	17		57	2	42	20		11
19		10	27	16	6	3	41	41	0	46½
20		9	36		14½	4	41	2		22
21		8	44		23½					North.
22		7	52		32	5	40	22	0	2½
23		7	0		40½	6	39	42		27
24		6	7		49	7	39	1		51½
25		5	13		57½	8	38	20	1	16
26		4	18	17	6	9	37	39		41
27		3	22		14	10	36	57	2	6
♂ 28		2	26		22½	11	36	15		31
Mar. 1		1	30		30½	12	35	33		56
2		0	33		38½	♂ 13	34	51	3	21
3	10	59	36		46	14	34	9		46
4		58	39		53½	15	33	27	4	10½
5		57	43	18	1	16	32	46		35
6		56	47		8½	17	32	5		59
7		55	51		16	18	31	24	5	23
8		54	55		23	19	30	44		47
9		53	59		29½	20	30	4	6	10½
10		53	3		36	21	29	25		34
11		52	7		42½	22	28	46		57½
12		51	12		48½	23	28	8	7	20½
13		50	18		54	24	27	31		43
14		49	25	19	0	25	26	54	8	5½
15		48	32		5	26	26	19		28
16		47	40		10½	27	25	44		50
17		46	48		15½	28	25	10	9	11
18		45	57		20½	29	24	38		32
19		45	7		25	30	24	6		53
20		44	18		29½	31	23	36	10	13
						April 1	23	7		33

CERES.				JUNO.							
1825.	R			Dec. N.	1825.	R			Dec. S.		
at 12 ^h	h	'	"	°	'	at 12 ^h	h	'	"	°	'
Feb. 18	12	22	38	15	26	May 31	18	25	44	4	58
19		22	10		32 $\frac{1}{2}$	June 1		25	3		56
20		21	40		39 $\frac{1}{2}$	2		24	22		54
21		21	9		46	3		23	40		52
22		20	36		53	4		22	57		50
23		20	3	16	0	5		22	13		48
24		19	28		7	6		21	29		46
25		18	52		14	7		20	44		44
26		18	14		21	8		19	58		42
27		17	34		28	9		19	11		40 $\frac{1}{2}$
28		16	53		35	10		18	24		39
Mar. 1		16	12		42	11		17	35		38
2		15	30		48 $\frac{1}{2}$	12		16	46		37
3		14	47		55 $\frac{1}{2}$	13		15	56		36
4		14	4	17	2 $\frac{1}{2}$	14		15	5		35
5		13	21		9 $\frac{1}{2}$	15		14	14		34 $\frac{1}{2}$
6		12	38		16	16		13	23		34
7		11	54		22 $\frac{1}{2}$	17		12	32		33 $\frac{1}{2}$
8		11	8		29	18		11	40		33
9		10	20		35 $\frac{1}{2}$	19		10	48		33
10		9	31		42	20		9	56		33
11		8	42		48 $\frac{1}{2}$	21		9	3		33
12		7	53		54 $\frac{1}{2}$	22		8	10		33
13		7	3	18	0 $\frac{1}{2}$	23	♂	7	17		33 $\frac{1}{2}$
♂ 14		6	12		6 $\frac{1}{2}$	24		6	24		34
15		5	21		12	25		5	31		35
16		4	30		17	26		4	38		36
17		3	38		21 $\frac{1}{2}$	27		3	45		37
18		2	46		26	28		2	52		38
19		1	54		30	29		2	0		39
20		1	2		34	30		1	8		40 $\frac{1}{2}$
21		0	10		38	July 1		0	16		42
22	11	59	18		42	2	17	59	24		44
23		58	26		46	3		58	32		45 $\frac{1}{2}$
24		57	35		49 $\frac{1}{2}$	4		57	41		47 $\frac{1}{2}$
25		56	44		53	5		56	51		49 $\frac{1}{2}$
26		55	54		56	6		56	1		52
27		55	4		59	7		55	11		54
28		54	14	19	1 $\frac{1}{2}$	8		54	22		56 $\frac{1}{2}$
29		53	25		3 $\frac{1}{2}$	9		53	33		59
30		52	37		5 $\frac{1}{2}$	10		52	45	5	1 $\frac{1}{2}$
31		51	49		7	11		51	59		4
April 1		51	2		8	12		51	13		7
						13		50	28		10

LXIV. *On Weights and Measures, and on numerical Notations, in reply to Mr. TREDGOLD. By A CORRESPONDENT.*

To the Editors of the Philosophical Magazine and Journal.

Gentlemen,

WHATEVER opinions concerning established practices or projected alterations of the national policy, with regard to matters within the scope of science, are promulgated in your pages, they derive great weight therefrom, and especially so, when suggested improvements come therein, from the pens of known benefactors to science, and the useful arts, as occurs with respect to Mr. Tredgold's communication in page 202, on a suggested *new gallon Measure*, and in objection to the decimal Notation: but, as sometimes the most able men are liable to take partial and inadequate views of particular subjects, and to make hasty and inconsiderate proposals for alterations, it is not only allowable, but becomes a duty incumbent on the most humble labourer in the field of science, who may discover and be convinced of evils, likely to follow from the general adoption of opinions, or on the making of changes, so introduced or proposed, to candidly submit his observations and reasons to the scrutiny of your readers. I shall, therefore, without further preface, proceed to make a few remarks on Mr. Tredgold's letter, which, at its outset, alludes to the Act of the last Session of Parliament, for regulating Weights and Measures, and for making, after the first day of May next, an entire change, embracing every Measure of capacity, ascertainable by a *measuring Vessel*, which heretofore has been in use in England.

Of this Act, a correct, although too brief an abstract has appeared in page 248 of the current volume of the "Monthly Magazine;" but, until the allusion by Mr. T., the subject of this important Act has somewhat surprisingly escaped notice in your pages*.

I am unable to anticipate with Mr. Tredgold, in his first sentence, that the enacted change of our measures of capacity will soon, or even eventually, take place; especially with regard to the corn Bushel, the measuring vessels for which are expensive ones—are dispersed far more widely, and in more persons' hands, the farmers, millers, corn-dealers, innkeepers, &c., throughout England and Wales: *the bulk, and the value* also of the articles ascertained by means of these vessels, and the frequency of their use, by some score times exceed the use, of any other denomination of measure used in South Britain.

* We have annexed the Abstract to our Correspondent's paper: see p. 366.
—ED.

In terms of the Winchester Bushel, the greatest number of facts regarding *prices*, and the consequent *value of money* at different periods, stand recorded, than with regard to any other measure: for these and many other reasons, which strike practical men, I have been always an opponent of the scheme, or mere whim I had almost said, of those who have prevailed in preferring the imagined *greater simplicity* of a Vessel (improperly called a *bushel*) which holds 80lbs. or 560,000 grains of rain water, and measures 2218·192 cubic inches, as compared with the long-established Winchester bushel, measuring 2150·42 cubic inches, and holding 542,890·5 grains, or 77lbs. 8oz. 14drs. avoirdupoise, and 76·9 grains troy, of rain water.

Will it be contended, that *the maker of bushel Measures*, and the official examiner and stamper of such measures, would not be equally capable of placing stamped weights, equivalent to the above number of pounds, ounces, drachms, and grains (amounting to 542,890·5, besides the tare of the vessel itself), as they would be, so to place 80lbs. in the opposite scale to that in which the vessel under examination, just full of rain water, is being weighed? and if this is not contended for, what other sufficient reason can be given why *the Winchester bushel* (so widely spread and universally used) should not remain, as *the integer of measures of capacity*, at least of those of its own class, instead of attempting, as the Act proposes to do, *to overturn the whole system*; but which, I feel confident, cannot be effected, and will not happen; and hope to see, on the meeting of Parliament, numerous petitions presented, praying that the clauses relative to measures of capacity, may be repealed, and the *Winchester bushel** adopted, as the future integer of these, in case that some *one measure* is to regulate them all.

If, gentlemen, the above forcible objections lie, against adopting the new (80lb) bushel, which is little more than 3 *per cent. greater than the present one*, how much greater are the objections against such a bushel as Mr. Tredgold indicates in page 302, of (8 × 339·293, or) 2714·344 cubic inches, which is 26½ *per cent. larger than the bushel in use*!, and whose 1-8th part is even 46 *per cent. larger than the present wine gallon*!

Engineers and calculators will do well to follow Mr. Tredgold's advice in using the cubic *foot** (rather than his example, as to the frequent use of the inch), as their standard for stating and comparing capacities or bulks, whatever fate may await the "imperial gallon." The

* In a new legislative definition of the *Bushel*, it would be well to state its lineal cylindrical dimensions and contents, in well-chosen *decimals of a foot*, instead of inches — and such, that the *gallon* and its subdivision might have

The objections urged at the top of page 303, against the French system of measures, are too vaguely expressed, for me to be sure that I understand their object; but this I know, from conversing with various intelligent Frenchmen, and with English engineers and artisans who have been much in France, that the practical objection to the new system is, that *for lengths* it furnishes no convenient *portable measure*. A rod or rule the length of a *metre* (of 39·37 inches nearly, of our measure) even if it were not too *long*, open, and too *clumsy*, when folded*, to be carried about in the pocket, always ready for use, is inapplicable, except in a few trades like drapers, mercers, &c.; and as to the *deci-metre*, of 3·94 inches long, what can be done with it, as a measuring rod or rule? singly it is far *too short*; and if three or four, or else six or seven of these decimetres are added or joined together, in order to produce rules, equally adapted to be carried in the pocket, and alike convenient, in the essential act of *measuring*, with the *one-* or the *two-foot* rules of France or England, how very inconvenient and liable to error must be *the counting* or adding-up mentally, several successive applications of such a rule, in the measurement of the lengths continually occurring in the artisan's practice, as of 20 or 30 feet lengths, for instance? In short, the difficulty is an insuperable one.

Had the terrestrial *circumference* been divided into 10,000,000 parts, instead of the quadrantal meridian thereof, and the metre been assumed at 4 times its present length; in such case a jointed rule $15\frac{3}{4}$ of our inches nearly, might have been carried in the pocket, and been used with not much more loss of time or inconvenience than attend the use of our two-foot rules; but, as it is, I fully concur with those who framed our late Act, in retaining the *foot* measure, as settled in 1760; and I wish they had been equally attentive to retain the capacity of a cylinder of $18\frac{1}{2}$ inches diameter and 8 inches deep (the bushel settled in 1697), and made it *the unit* of measuring vessels †.

That phantom, "the nature of things," would be still more

as few decimal places as may be. Which gallon, for avoiding confusion, should not be called *Winchester*, because of the 282 cubic inches, long ago enacted and used in gaugings for ale, beer, and vinegar; neither should it be called "Imperial" (=277·274in.), but *British* should, I submit, be used as the prefix to the gallon, quart, pint, gill, &c. of this system.

* The same objection applies to the English *yard*, as *not being a practical measure*, equally with the *foot*; it is suggested, therefore, that in an amended Act, the *foot*, one-third of the yard, defined in clause 1 of the present Act, should be more expressly named as a standard, or *unit* of lengths, for defining other measures, in clauses 1, 2, 7, 8, and 14.

† Where a *gallon* vessel is once used in measuring goods, there cannot be a doubt but the *bushel* is so used a hundred, nay perhaps a thousand times!

absurdly

absurdly followed than has been done by our French neighbours, with regard to the quadrantal arc, as shown above, were we to listen to any proposals, however ingeniously urged, for abandoning the *decimal* notation, after it has become incorporated in every operation and act of civilised society, wherein numbering or computing is concerned. All the extra labour and difficulties of which Mr. T. complains, with regard to decimal computations, arise from an absurd adherence to the number 3 and 4 in *dividing our measuring rods* or rules : and I have been pained at the reading of the latter half of Mr. T's letter, at reflecting, that instead of these speculations, which I cannot but view as worse than useless, he might, most beneficially for his own reputation and the progress of knowledge, in his several most useful and practical writings, have recommended engineers and artisans, and himself (an advocate "for the *foot* as a measure") have set the example, of *taking small dimensions*, not in inches, but in *the hundredths of a foot*, which are provided on the edges of all, but the very commonest, of our pocket rules.

As to our *monies*, to which Mr. T. alludes, near the top of page 304, it has been well shown in your 49th volume, with what extreme ease and accuracy, and with what slight efforts on the part of Government, they might all be reduced to a *decimal* scale. As to calculations of *time*, to which he next adverts; in adding up any series of minutes and seconds, or in performing subtraction, no labour or difficulty worth mention occurs from the carrying and borrowing of 6 (in effect 60) in the second *decimal* place; and as to multiplying or dividing of these, or other sexagesimals, they never occur, but to a particular and very limited class of persons, who either have, or may have by them, tables for facilitating these kind of calculations:—as to *weights* and *measures* next mentioned, the attempt to reduce these in England to decimal scales, is too arduous and hopeless of success *at present*, to be undertaken.

Decimal *coins* and *money accounts*, if adopted by the government, as already indeed is the case in enumerating their millions, and with all sums above 20 shillings, and even these last are *decimally* stated when above 9:—when these are become familiar to the public, particularly to the youths in our schools; and when *dimensions taken in decimals of a foot* (as already they mostly are of an inch, to the disuse of the barley-corn) are pretty generally adopted by engineers, surveyors, and the directors of artisans, and by experimentalists and writers generally; then, something important may be done. In the mean time, a repeal of the "imperial gallon" clauses, with the substitution in a new Act, of clauses, *ascertaining*
(as

(as has been done with regard to the troy and avoirdupoise pound, and the yard and foot), and *defining and legalizing* of the other units of the principal systems of measures *in use*, like the corn and the coal *Bushels* and their multiples and sub-multiples, the wine and the beer gallons, and their mults. and submults. &c., is all which myself or the present race of your readers have, I fear, any reason to expect to see realized.

I am your's &c.

November 2nd, 1824.

DECAPHILUS.

Abstract of an Act of the last Session of Parliament for regulating Weights and Measures.

By the Act 5 Geo. IV. Cap. 74. "For ascertaining and establishing uniformity of Weights and Measures," it is enacted, that from and after the 1st of May, 1825, the standard brass yard made in 1760, at the temperature of 62° by Fahrenheit's thermometer, shall be, and be denominated, the "Imperial Standard YARD," and shall be the unit or only standard measure of extension, whereby all other means of extension, whether lineal, superficial, or solid, shall be computed and ascertained according to the proportions for certain measures of extension specified in the act.

And that if the said imperial standard yard shall be lost or injured, it shall be restored by making a new standard yard, in the portion of 36 inches to $39\frac{1393}{10000}$ inches, when compared with a pendulum vibrating seconds of mean time, in the latitude of London, in a vacuum, at the level of the sea.

Also, that after the 1st of May, 1825, the standard brass weight of one pound, troy-weight, made in the year 1758, shall be the "Imperial Standard TROY POUND," and shall be the unit or only standard measure of weight, from which all other weights shall be computed and ascertained, according to the proportions for certain other weights specified in the act.

And that if the said imperial standard troy pound shall be lost or injured, it shall be restored by making a new standard troy pound, bearing the same proportion to the weight of a cubic inch of distilled water as the said standard pound, thereby established, bears to such cubic inch of water; that is to say, 5·760 cubic inches of distilled water, weighed in air, at the temperature of 62° of Fahrenheit's thermometer, the barometer being at 30 inches, each such cubic inch of water, when so weighed by brass weights, being equal to $252\frac{458}{10000}$ grains, and that 7,000 such grains shall be one POUND AVOIRDUPOISE.

It further enacts, that after the 1st of May, 1825, the standard measure of capacity, as well for liquids as for dry goods, not measured by heaped measure, shall be the gallon containing ten pounds

pounds, avoirdupoise-weight, ascertained as before-mentioned, of distilled water weighed in air, at the temperature of 62° of Fahrenheit's thermometer, the barometer being at 30 inches, and such measure, when made, shall be the "Imperial Standard GALLON," and shall be the unit and only standard measure of capacity, from which all other measures of capacity shall be computed and ascertained, according to the proportions for certain other measures of capacity specified in the act.

Also, that the standard measure for goods, and things commonly sold by heaped measure, shall be the BUSHEL, containing eighty pounds avoirdupoise of distilled water, the same being made round, with a plain and even bottom, and being $19\frac{1}{2}$ inches from outside to outside, and the goods and things shall be duly heaped up in the form of a cone, such cone to be of the height of at least six inches, and the outside of the bushel to be the extremity of the base of such cone.

The act likewise directs how copies and models of the said imperial standard weights and measures shall be distributed and brought into general use, and how local disputes, respecting the correctness of measures of capacity, shall be locally adjusted; and it repeals all former statutes, except nine, on the subject, specifically sixty-three in number!

LXV. *On some Extraordinary Inconsistencies in the Greenwich Observations for 1821.* By S. LEE, Esq.

To the Editors of the Philosophical Magazine and Journal.

Gentlemen,

BEING lately engaged in the investigation of a question which requires a reference to the most accurate astronomical observations that can be procured, I naturally turned to those of the royal observatory at Greenwich; but the results which I obtained from them, were by no means satisfactory to my purpose. The first impression on my mind was, that I must have fallen into some mistake in respect to the conclusions which I had supposed could be drawn from them, and under that impression I gave up the inquiry. A hint however, which I shortly afterwards received from a friend, to whom I accidentally mentioned the circumstance, led me to suspect that my disappointment was occasioned, not by any false reasoning in the investigation alluded to, but by errors in the observations; and a careful, though not yet complete examination of those for 1821, have fully confirmed my suspicions. What the exact nature and extent of these errors are, cannot be precisely ascertained; but that they must be errors, or palpable inconsistencies,

consistencies, will evidently appear, from the following short abstract of a comparison of the observations as recorded in different parts of the book with each other; and which, for the sake of perspicuity, I have arranged in separate classes.

The first class are those which were pointed out to me by my friend, and are to be found in the North Polar Distances, deduced from the observations with the mural circle, from the readings with two—and with six microscopes. Those discovered in the observations with two microscopes alone are at least sixty in number, and frequently amount to more than 1".

The second class was discovered by comparing the readings with the microscopes A and B, as given under the head of observations with two microscopes, with the same given under the head of observations with six microscopes: of these errors sixty-four have been discovered.

The third class are to be met with in the extraordinary disagreement between the heights of the barometer and thermometers, as recorded under the separate heads of observations with two—and with six microscopes; and amount to two hundred and eighty-six in number.

I shall content myself at present with a bare statement of these three classes of errors only, reserving any observations on them, and some others, of perhaps still greater consequence to the reputation of the observatory, to a future communication. In the mean time I think it is due to the character of Mr. Bensley, to state, that they are not errors of the press, a fact which I have ascertained by a comparison of the printed copy with the original manuscript deposited in the archives of the Royal Society.

I am Gentlemen,

Your obedient humble servant,

STEPHEN LEE.

London, Nov. 24, 1824.

CLASS I.

Page.			A	B	o	'	"	True Mean.
177	♀ Feb. 2	Sirius .	8·8	18·8	106	26	11·8	13·8
185	♂ Apr. 10	Regulus .	56·2	25·0	77	9	0·6	10·6
								or 40·6
186	♀ 20	β Leonis .	2·0	11·0	74	25	9·5	6·5
194	♂ June 26	Arcturus .	18·0	14·2	69	52	21·1	16·1
200	♂ Aug. 11	♄ LL. .	51·2	54·5	114	56	52·5	52·8
209	♄ Oct. 29	α Cygni .	18·0	25·0	45	20	21·0	21·5
210	Arcturus .	6·2	16·0	69	52	12·5	11·1
	☉ Nov. 4	α Cassiopeix	50·1	51·0	34	25	58·6	50·5
219	♃ Dec. 13	Polaris SP.	34·0	54·0	358	21	54·6	44·0

And other similar errors, amounting in all to 60 in number.

CLASS III. continued.

Page			Barom.	Ther. within.	Ther. without.
		Sirius	37	36
		39	36
		α Cygni	36	34
		35	34
178 } 227 }	γ Feb. 8	α Arietis	30.42		
		30.41		
	ζ 9	Castor	35	32 $\frac{1}{2}$
		35	32
	" . . .	Procyon	35	32 $\frac{1}{2}$
		35	32
		α Cygni	42	43
		41	43
179 } 228 }	ϵ Feb. 12	α Persei	37	35
		38	35
	γ . 15	Polaris S. P.	30.36		
		30.32		
	\odot . 18	α Lyræ, α Aquilæ, } and α Cygni	30.15		
		30.13		
180 } 288 }	δ Feb. 23	β Tauri	34
	ζ	34 $\frac{1}{2}$
	η . 24	Polaris	29.99	35	37
		29.97	36	37
		Aldebaran	29.98		
		29.97		
180 } 229 }	δ . 27	α Orionis	30	26
		31	26

And similar errors in the remaining months, in all amounting to 286 in number.

LXVI. *On some Observations in the Meteorological Register.*
By W. BURNEY, LL.D.

To the Editors of the *Philosophical Magazine and Journal*.

Gentlemen,

IN looking over the meteorological table at the end of your last Number, and comparing the state of the barometers at Gosport, London, and Boston, I perceive a mistake in the pressure at Boston on the morning of the 12th of October. The state of the barometers at Gosport and London, after the heavy rains on the 10th and 11th of October, was nearly quiescent on the 11th and part of the 12th, with the wind here veering from S. to N.; but at Boston it does appear by the table that the mercury in Mr. Veall's barometer rose exactly

actly *one inch* in that time. Thinking it might have been a typographical error, I was induced to add up and find the mean of the month's pressure at Boston, but found that 29·75 inches in the morning of the 12th of October had been added to make up the mean pressure 29·43 for the month.—If the pressure that morning was only 28·75 inches, as I have reason to suspect it was from the quiescence of the barometers, in that case the mean for the period is 29·40 inches.—I merely mention this circumstance for Mr. Veall's consideration, as I intend to give the monthly and annual results of the tables; and if he admit it as an inadvertent error, an *erratum* to that effect should either be made in your next Number, or at the end of the volume*.

In a close collation of the tables for this year, I also find that Mr. Veall's barometer in the morning of the 24th of July, was ·63 of an inch lower than mine, that is nearly ·4 of an inch less than its comparative mean level. The weather then being fine and very dry at both places, and for some days before and after, it would be difficult even to attempt to investigate the cause of so great a difference in the pressure of the atmosphere at the respective places, without the precise state of the hygrometer and wind, which I can only get from my own register. If Mr. Veall could conveniently register the position of the wind when he takes the altitude of his barometer, it would certainly tend to throw some light upon the subject of great deviations from the comparative mean pressures at Gosport and Boston; and it were much to be wished that your London register gave the state of the barometer at 8, or half-past 8, A.M., instead of at 1, P.M.; as one of the chief objects of a monthly meteorological table in your valuable Magazine, is *comparison*, which will be materially obviated without simultaneous observations on the instruments at the time proposed.

I am, gentlemen,

Your obedient servant,

Gosport, Nov. 25, 1824.

WILLIAM BURNEY.

LXVII. *Notices respecting New Books.*

Recently published.

THE Second Part of volume XIV. of the Transactions of the Linnæan Society of London, has just appeared; and the following are its Contents:—

A Commentary on the Second Part of the Hortus Mala-

* On referring to Mr. Veall's MS., we find that it is 29·75.—EDIT.

baricus; by Francis Hamilton, M.D.—The Natural History of *Xylocopa Teredo* and *Horia maculata*; by the Rev. Lansdown Guilding, B.A.—On the Nature of the Marine Production commonly called *Flustra arenosa*; by John Hogg, Esq. B.A.—Description of a new Species of *Onchidium*; by the Rev. Lansdown Guilding, B.A.—Descriptions of Nine new Species of the Genus *Carex*, Natives of the Himalaya Alps in Upper Nepal; by Mr. David Don, Libr. L.S.—An Account of some rare West Indian Crustacea; by the Rev. Lansdown Guilding, B.A.—Observations on some of the Terrestrial Mollusca of the West Indies; by the Rev. Lansdown Guilding, B.A.—Descriptions of two new Species of *Erythrina*; by Felix de Avellar Brotero, Professor of Botany at Coimbra, F.M.L.S.—On the Insect called *Oistros* by the Ancient Greeks, and *Asilus* by the Romans; By William Sharp MacLeay, Esq., M.A. F.L.S. Some Account of a Collection of Arctic Plants formed by Edward Sabine, Esq., F.R.S. and L.S., Captain in the Royal Artillery, during a Voyage in the Polar Seas in the Year 1823; By William Jackson Hooker, LL.D. F.R.S. L.S. and H.S.

Messrs. Harding and Co. have published “The Perennial Calendar, or Companion to the Almanack.” This work contains, besides an illustration of the subject of the Almanack, a variety of original letters, poetry and miscellaneous writings, from the MS. of celebrated persons, who were educated at our universities, viz. Porson, Byron, &c. Also some notices of the average day on which different plants are found to flower, by a comparison of Journals for twenty years past, forming a sort of calendar of Flora on a new scale.

The Natural History of the Bible; or, A Description of all the Quadrupeds, Birds, Fishes, Reptiles, and Insects, Trees, Plants, Flowers, Gums, and Precious Stones, mentioned in the Sacred Scriptures. Collected from the best Authorities, and alphabetically arranged. By Thaddeus Mason Harris, D.D. of Dorchester, Massachusetts.

Outlines of a System of Medico-Chirurgical Education, containing Illustrations of the Application of Anatomy, Physiology, and other Sciences, to the principal practical Points in Medicine and Surgery; with coloured Plates. By Thomas Turner, Member of the Royal College of Surgeons of London, &c.

Smith's History and Description of the Steam-Engine. Octavo, with a Quarto Plate. 1s. 6d.

The Mechanic's Oracle, containing 20 Quarto Copper-plates. Parts I. to V. 2s. each.

ANALYSIS OF PERIODICAL WORKS ON NATURAL HISTORY.

Curtis's British Entomology.

No. 11, contains the following subjects :

Pl. 43. exhibits figures of *Scolytus destructor*, a species of tree-feeding insects, which threatens destruction to the elms in and about London ; an account of its ravages and the probable consequences first appeared in our Journal for Oct. 1823. Vol. lxii. p. 252.—Pl. 44. *Clerus albvarius*, a beautiful species, well known upon the continent, but new to this country. We have heard since this figure was published, that another specimen of it has been taken near Dorking in Surry, much larger than that figured in the plate.—Pl. 45. *Cucullia Asteris*. This beautiful and rare shark moth has been bred by Mr. Blunt, from caterpillars taken near Town : figures of this insect with its larva have never before appeared in any British work.—Pl. 46. *Asilus germanicus*. A very striking species of this curious genus, never before recorded as British : the only specimens we know of are preserved in our National Museum.

Curtis's Botanical Magazine. No. 453.

Pl. 2517. *Aloe africana*, β *angustior*. This species had never heretofore been figured in flower ; nor had Mr. Haworth seen it in flower when he published his Arrangement of the genus. *Cotyledon decussata*, the *papillaris* of Haworth, but not of Thunberg.—*Lobelia Rhizophyta*.—*Euphorbia anacantha*.—*Schizanthus porrigens* ; " caule diffuso, racemis paniculatis : pedicellis divaricatissimis."—*Crinum confertum* : from the N.W. coast of Australia.

The Botanical Register. No. 216.

Pl. 832. *Brassia caudata* ; " sepalis ovato-lanceolatis acuminatis : inferioribus caudatis, labello acuminato, bulbo ancipite : " an Orchideous plant from the West Indies, belonging to the section *Epidendrea*.—*Nicotiana nana* ; " 2—3 uncialis, foliis lanceolatis pilosis : radicalibus quam flores solitarii longioribus, corolla calyce longiore : laciniis obtusis." Raised by the Horticultural Society from seed from the Rocky Mountains of North America, and stated to be that from which the Indians prepare the finest of their tobacco, but not to have been noticed in the works of American botanists.—*Melodinus monogynus* ; " foliis ovali-lanceolatis acuminatis, paniculâ glaberrimâ : " in the *Hortus Bengalensis* of Dr. Carey it is said to be a climbing shrub, native of Sylhet, and flowering at Calcutta in March and April.—*Scabiosa graminifolia* : the characters of the genus and species are given from Dr. Coulter's recent Monograph of the Natural Order of *Dipsacæ*, which receives merited commendation.—*Gualteria rufa*, Decandolle's Prodrômus, t. 93, where 22 species of this interesting genus are enumerated, of which not one was known to Linnæus :—sent to the Horticultural Society from China by Mr. Potts.—*Pedilanthus Tithymaloides*, a genus of Necker retained by A. de Jussieu, scarcely distinguishable from *Euphorbia*, except by the very curious and peculiar form of the involucre.—*Heliophila digitata*.—*Acacia calamifolia* : " petiolis filiformibus longissimis cernuis, pedunculis solitariis petiolo multoties brevioribus, legumimbus arcuatis articulatis corrugatis : " an apparently undescribed species, brought from the south-west interior of New Holland, under the name of the Bodkin-leaved *Acacia*.

LXVIII. *Proceedings of Learned Societies.*

ROYAL SOCIETY.

Nov. 18.—**T**HE Croonian lecture, by Sir E. Home, bart., V.P. R.S. was read: it related to the discovery of nerves on both the foetal and the maternal surface of the placenta. And a paper by the same author was also read, On the changes undergone by the Ovum of the Frog, during the formation of the Tadpole.

Nov. 25.—A paper was read, On a method of calculating the angles of crystals, by W. Whewell, M.A. F.R.S. and Fellow of Trinity College, Cambridge.

LINNÆAN SOCIETY.

The Linnæan Society resumed its sittings for the season on the 2d of November, A. B. Lambert, esq. V. P. in the chair. Read a letter from Mr. J. D. C. Sowerby to Mr. R. Taylor, giving an account of some specimens of a fresh-water shell, probably the *Mytilus polymorphus*, found by Mr. Bryant plentifully attached to timber in the Commercial Docks. It is found in the Danube, whence probably it may have been brought here in timber.

A Description of three Species of British Birds; two of them new to the ornithology of the British Islands. By N. A. Vigors, Jun., Esq. A.M. F.L.S. The species are: 1, *Anthus Richardi*, Viellot; Fam. Sylviadæ, Vigurs. Two specimens of it were taken in 1810 and 1812 at Kingsland near London. 2, An undescribed species of *Scolopax* shot in Queen's County in August 1822, and named *Scolopax Sabini*. 3, *Querquedula glocitans*.

A Description of *Cowania*, a new genus of plants, and of a new species of *Sieversia*. By Mr. David Don, Libr. L.S.

These two remarkable plants of the family of Rosaceæ are from a large Mexican collection, part of the Herbarium of Mocinno and Sessé, now in Mr. Lambert's possession.

Cowania. Char. essent. Cal. 5-fidus. Petala 5. Ovaria 5-7, ovulo erecto. Styli teminales, continui. Achenia stylis plumosis persistentibus aristata. Embryo erectus.

Sieversia paradoxa foliis fasciculatis linearibus obtusis sessilibus integris 3—5-fidisve, floribus subcorymbosis, stylis plumosis, caule fruticoso.

Nov. 16.—A. B. Lambert, Esq. V.P. in the chair: among the visitors were Prince Gemitelli and General Turner. Read a letter from John Atkinson, Esq. F.L.S. of Leeds, to A. MacLeay, Esq. Sec. L.S., accompanying some specimens of Beetles found in abundance in an Egyptian mummy in the museum at Leeds.

Description

Description of several species, hitherto unpublished, of the genus *Coccinella*; by George Milne, Esq. F.L.S. communicated from the Zoological Club. The new species are: *C. circumdata*, Brazil; *28-maculata*, N. Holland; *18-maculata*, N. Holl.; *cordata*, N. Amer.; *connata*, N. Amer.; *4-fasciata*; *ephippia*; *parva*; *6-guttata*; *decussata*; *abdominalis*; *cyanea*, Brazil.

Observations upon the *Motacilla Hippolais* of Linnæus, by the Rev. Revett Sheppard, F.L.S. communicated from the Zoological Club. The conclusion come to by the Author is, that the *M. Hippolais* of Linnæus is the Greater Pettychaps.

An Account of some Plants belonging to the Natural Order called by Dr. Jack Cyrtandraceæ, by Francis Hamilton, M.D. F.L.S. The species described are *Chelone filiforme*, *rubicunda*, and *latifolia*.

GEOLOGICAL SOCIETY.

Nov. 5.—A paper was read entitled “Observations on a Comparison between the beds below the Chalk in the Isle of Wight, and in the counties of Surrey, Kent, and Sussex;” by Thomas Webster, Esq., Sec. G.S.

Mr. Webster stated, that in a late visit to the Isle of Wight, he had been so fortunate as to discover a rock of the same nature as the calciferous sandstone of Hastings, a circumstance that has furnished him with a fixed point, by means of which he had been enabled to compare the beds in the Isle of Wight with those of the S.E. part of England more correctly than had been done before; and he presented a table of what he considered as the equivalent beds in these two places.

He imagined that these equivalents had been hitherto stated erroneously by several geologists; and he attributed this chiefly to the following causes. 1st, The imperfect state of the science of geognosy, which had not as yet established fixed principles of classification; 2d, The want of acknowledged *Types* of beds or formations to which all other parts might be referred; 3d, The difficulties attending actual examinations, arising from the deficiencies or want of continuity of some beds, and the variation in the composition and structure of others,—difficulties which had, in his opinion, been underrated.

The author then proceeded to point out in detail what he conceived to be the history of some of the errors that had been fallen into. Thus, until lately, the description given by various geologists of the rock called *green sand* were supposed to be applied to *one* bed only; whereas, in fact, there are *two* beds distinct from each other, the undercliff of the Isle of Wight, and the rock of Folkstone, each of which had received this denomination. Also in the groups which it had been found necessary

necessary to form, they had not agreed with each other as to the individual beds inclosed in one group. Thus, some had formed a group (which they called *the ferruginous sand*) of the sands *above* and *below* the weald clay; while others had attached the name of Ferruginous sand to those *below* the weald clay *only*. He had also reason to fear, that an error had been committed in not identifying the beds which are called *the ferruginous sand* on the west of the chalk; as the Carstone, Wobourn sand, and the Farringdon bed, with the beds in the wealds of Kent and Sussex, to which the name of *green sand* had been given.

The following is the table of equivalent beds above alluded to.

Localities in the Isle of Wight.	Localities in the S.E. part of England.	Names proposed for the equivalent beds.	Groups.
Culver Cliff.	Guildford.	Chalk with flints.	Chalk formation.
Do.	Do.	Chalk without flints.	
Do.	Do.	Chalk marl.	
Undercliff.	Riegate, Merstham, and Beachy-head.	Upper green sand.	Green sand formation.
Do.	Folkstone cliff.	Blue marl of the green sand.	
Red Cliff, Atherfield and Blackgang.	Folkstone, Leith hill, &c.	Lower green sand, or Ferrugino-greensand.	
Sandown bay and Brixton bay.	Wealds of Kent and Sussex.	Weald clay.	Not yet named.
Cowleaze Chine.	Hastings.	Hastings limestone.	
Sandown, Brook point.	Hastings and Fair light.	Hastings sand-stones and clays.	
	Isle of Purbeck.	Purbeck beds.	
	Isle of Portland.	Portland beds.	

Nov. 19.—A paper was read “On the Purbeck and Portland beds,” by Thomas Webster, Esq., Sec. G.S.

The author observed, that the great general features of the geology of the Isle of Purbeck had been already traced out by him in his letters to Sir H. Englefield. He now confined himself to some details respecting the series of limestone beds in the Isle of Purbeck, and to those in the Isle of Portland.

He then proceeded to give a description of the strata from which the well known Purbeck stone used in London for side pavements,

pavements, &c. is derived. This stone is composed almost entirely of fragments of shells; the Purbeck marble contains chiefly univalves in a compact limestone, and these in general are smaller than the univalves of the Petworth marble, both having been supposed to belong to freshwater shells; but the author possessing specimens that contain a mixture of marine with fresh-water shells, he cannot consider this as a decided fresh-water formation, a term that in his opinion ought to be restricted to those beds supposed to have been formed in *lakes only*. The common Purbeck stone appears to consist of fragments chiefly of small bivalves of which the origin is doubtful.

Mr. Webster then gave a detailed account of the quarries of the Isle of Portland, which furnish the Portland stone much used in our public buildings. The Isle of Portland consists of a calcareous mass lying upon a bed of bituminous clay and limestone identical with the Kimmeridge beds. The lower and more considerable part of the limestone in the Isle of Portland above the Kimmeridge clay is chiefly oolitic, and contains beds of chert; but the upper part consists of a yellowish calcareous stone nearly compact, which contains in it a bed of earthy lignite, abounding in silicified portions of trunks of trees about two or three feet long, some of which are erect, and others are lying flat. As far as he could ascertain, the fossil wood was nearly confined to this stratum, and not dispersed through the oolite as had hitherto been supposed. These upper beds of the Isle of Portland, he considered as belonging to the same formation as the Purbeck beds, having found some very similar in the Isle of Purbeck.

Considering the fossil shells of the Portland oolite to be marine, while those of the Purbeck limestone are chiefly fresh-water, together with the great mineralogical difference of character, the author stated it as his opinion, that the two series of beds should be kept in separate groups in arranging the English strata.

HORTICULTURAL SOCIETY.

Sept. 7.—The large silver medal was presented to Robert Austen of Glasgow, a Corresponding Member of the Society, for the successful cultivation of Scotch roses, many new varieties of which have been raised by him, and presented to the garden of the Society.—The large silver medal was also presented to Peter Cæsar Labonchere, Esq., F.H.S., for having introduced and encouraged the Dutch method of early forcing.—The large silver medal was also presented to Mr. Henry Burn, gardener to the Marquis of Aylesbury, a Corresponding Member of the Society, for having raised the seedling grape called the Tottenham Park Muscat.

The following papers were read :

On the cultivation of the raspberry. By Mr. John Mearns, F.H.S.—On a method of forcing the vine into fruit in unfavourable situations. By M. Vauden Creuysse.

Oct. 5.—The following papers were read :

On a means of arresting the sap in pear-trees. By the Rev. John Fisher.—On the classification of cherries. By Mr. John Robertson, F.H.S.

ASTRONOMICAL SOCIETY.

This Society held its first meeting after the summer recess, on Friday the 12th of November; the President, H. T. Colebrooke, Esq. in the chair. Several new members were elected, and others proposed, and a great number of valuable presents, especially from foreign astronomers, were announced.

Two communications were read from Sir Thomas Brisbane, Governor of New South Wales. The first of these contained an account of some observations made at Paramatta, by Sir Thomas, and Mr. Dunlop, on the inferior Conjunction of Venus with the Sun, in October last. The observations were made with a mural circle of Troughton's, which Sir Thomas characterizes as of remarkable steadiness, and so well in the meridian, that with *Antares* and γ *Draconis*, and any other of the high and low stars, it gives the same right ascension. The observations extend from the 6th to the 25th of October. The account exhibits the polar distances, and the times of culmination of the Sun and Venus, as well as of *Antares*, β *Argo*, and α *Lyræ*; to show the state and position of the instrument. The latitude of the observatory at Paramatta is stated to be $33^{\circ} 48' 43''$ South. Longitude East of Greenwich $10^{\text{h}} 4^{\text{m}} 5^{\text{s}}$.

Sir Thomas's second communication, which is dated 17th April, 1824, contains, First, A record of repetitions on the Sun, with Reichenbach's circle for the Summer Solstice, 1823; they extend from December 10th, 1823, to January 2d, 1824, but have not yet been subjected to the necessary reductions for a definite result. Secondly, A series of observations on several stars made at Paramatta, with the mural circle, from November 20th, 1823, to February 19th, 1824. Twenty of the stars observed are among those, whose places are given annually in the Nautical Almanac, and are usually denominated Greenwich stars.

A letter was also read from Baron Zach to Francis Baily, Esq. F.R.S. dated Genoa, 31st July, 1824, announcing the discovery of a telescopic comet, by M. Pons, on the 24th of that month. It was in the head of *Serpentarius*, without tail

or

or coma:—a simple nebulosity. M. Pons's observations on the comet, and some stars near it, from the 25th to the 28th of July, accompany this communication; but as the comet was, even then, rapidly approaching the Sun, they need not now be recorded.

Mr. Herschel submitted to the inspection of the members present, a new double image micrometer, by Professor Amici of Modena. The duplication of the image in this ingenious instrument is effected by interposing a divided concave lens of very long focus between the object and eye-glasses of a refracting, or between the mirror and eye-glass of a reflecting telescope. The separation of the centres of the two segments is performed by a rack and pinion sliding them on one another, their edges being preserved in contact, and is measured on a divided scale with a vernier in the usual manner. It is obvious that each segment will form a separate image of a distant object, more remote from the object end of the telescope than its principal focus, and the value of the parts of the scale is easily had from the expression,

$$1'' \times \frac{\phi\phi'}{\phi-\alpha} \quad \text{or} \quad 0\cdot0000048481 \times \frac{\phi\phi'}{\phi-\alpha}$$

where ϕ is the focal length of the object lens or mirror, ϕ' of the bisected lens, and α the distance of the latter from the former, all expressed in parts of the same scale into which the micrometer is divided. This expression gives the number of parts of such scale which represent $1''$ of angular measure, and conversely, the value of one part of the scale, in seconds, will be the reciprocal of this fraction.

This micrometer possesses several advantages, among which may be reckoned, simplicity of construction and use; the magnitude of its scale, which may be increased to almost any extent by an increase of the focal length of the bisected lens (ϕ'), and lastly the advantage of dispensing with a table of reduction, by so fixing the place of the divided lens as to render one part of the scale correspondent to $1''$ of angular measure. In fact, if we equate the above expression to unity, we get

$$\alpha = \phi \{1 - 0\cdot0000048481 \times \phi'\}$$

and if this be the distance of the divided lens from the object glass, one part of the scale will correspond to one second. Mr. H. in his visit to Modena, in the spring of the present year, had an opportunity of trying this instrument as applied to celestial objects, in one of M. Amici's superb reflecting telescopes of 12 inches aperture and 8 feet focus. The following, among other measures, were taken.

Distance of the two stars of Polaris (single measure)	18.40
Jupiter's Polar diameter (mean of 6 measures)	32.54
———— Equatorial do. do.	34.06

Consequently ratio of diameters 1.0467

Mr. Donkin laid on the table, for the inspection of the members, an instrument made by M. Fatton (a pupil of Breguet's at Paris) for determining the *fractional part* of a second of time, in astronomical observations. This piece of machinery is about 5 inches in diameter; and somewhat larger than the ordinary size of ship chronometers. The instant of observation is marked by a very fine point attached to a spring, which (by means of a peculiar kind of ink) makes an impression on the dial plate. The machine will go for five hours. It is impossible to enter into any further description of this ingenious piece of mechanism, without the assistance of plates and numerous references: but we hope the inventor will be induced to lay the whole before the public, at no distant period.

Prize Questions proposed by the Astronomical Society of London.

This Society has just proposed the following prize questions, to the consideration of astronomers and mathematicians: viz.

1st. *The silver medal.* To any person, who shall contrive, and have executed an instrument, by which the relative magnitudes of the stars may be measured or determined; and of which the utility for this object shall be sufficiently established, by numerous observations and comparisons of known stars.

2d. *The gold medal.* For approved formulæ, for determining the true place of either of the four newly discovered planets, Ceres, Juno, Vesta, and Pallas: within such limits as the Council may think sufficiently correct for the present state of astronomy;—such formulæ in each case to be accompanied with comparisons of the observed places at various periods.

3d. *The gold medal.* For a new mode of developing the differential equations for expressing the problem of the three bodies, by which a *smaller number* of tables shall be required in order to compute the Moon's place to the same degree of accuracy as by any existing tables, and with greater facility.

To be entitled to competition for the prizes, all answers to the first question must be received before the 1st of February, 1826; to the second, before the 1st of February, 1827; and to the third, before the 1st of February 1828.

LONDON MECHANICS' INSTITUTION.

It gives us much pleasure to state, that this important Institution

stitution which, though labouring under some disadvantages for want of a suitable building, has already, with the aid of lecturers of the first respectability, furnished an extensive course of instruction to a large body of Members, is now provided with a convenient house for its Schools, Library, Museum, &c. and that the first stone of the Theatre or Lecture-room is to be laid on the 2nd of December, being the first Anniversary of the Institution. The day is to be celebrated by a Dinner at the Crown and Anchor Tavern, Dr. Birkbeck in the chair.

ROYAL ACADEMY OF SCIENCES OF PARIS.

May 24.—The Academy received a Memoir, by M. D'Hombres-Firmas, containing Observations on Fossils, and particularly on Ammonites; a description of a new Astronomical Instrument, by the Count de Zuylen of Nyevelt; a sealed packet from M. Castille, clockmaker, relative to an investigation in which he is engaged; and a Refutation of Newton, by J. B. Souton.—M. Vauquelin made a report on M. Dublanc's Memoir on the application of Tincture of Galls, as a means of detecting the presence of morphia.—The Academy elected M. Fresnel as a candidate for the office of Professor of Natural Philosophy in the College of France.—M. Legendre made a report on the new Manuscript Tables of M. Bagay.—M. Poisson, in the name of a Commission, made a very favourable report on M. Damoiseau's Memoir containing the calculus of the Perturbations of the Comet of the short period.—M. Paixhans read a Memoir in which he examined the question whether Steam-engines can be employed in the art of war.—M. G. St.-Hilaire presented a Memoir on the analogy existing between the *filets pêcheurs* of the Lophius and the ascending apophyses of the vertebrata; especially with the first rays of the dorsal fin of the Siluri.—A Letter from M. Audouin was read, on the use of a vesicle which accompanies the female organs of generation in insects.

May 31.—M. Lassaigne read his Chemical Researches on the means of determining the presence of hydrocyanic acid in animals poisoned by that substance.—M. Magendie stated that he was proceeding with his experiments on the fifth pair of nerves.—M. Becquerel read some new elucidations of the electrical effects observed in chemical action.—M. Auguste St.-Hilaire read a Memoir in which he mentioned the poisonous effects of the honey of the Lecheguana wasp. M. Desmoulins read a Memoir on the differences between the nervous system of the Lamprey and that of the other vertebrata.

June 14.—A Memoir was received from M. Féburier on various properties of the electric fluid, and a new refutation of
Newton,

Newton, from M. Souton.—M. Latreille read a report on M. Léon Dufour's Researches on the Anatomy of the Coleoptera.—M. Arago gave an account of his experiments on the light which emanates from incandescent bodies.—M. Cuvier read a Memoir on the Plesiosaurus.—M. Geoffroy Saint-Hilaire read a Memoir on the Auditory Faculties of Fishes.

June 21.—M. Girard read a Memoir, entitled the "Application of the principles of Dynamics to the purpose of determining the respective advantages of different modes of carriage."—M. Laugier commenced reading his Chemical Examination of the Minerals from the Island of Ceylon.—M. de Wiebeking read some Observations on the state of Civil Architecture in the middle ages, and on the means by which the monuments of those periods were executed.

June 28.—M. Puissant communicated to the Academy an account of a new instrument which he calls a *panorograph*, by means of which the perspective of a panorama may be traced with accuracy and ease.—M. Zamboni, Professor of Natural Philosophy at Verona, transmitted a Memoir on dry electric piles.—M. Dulong read a Letter addressed to him by M. Pouillet on the means of measuring elevated temperatures, and especially that which exists at the surface of the sun.—M. Girard, in the name of a Commission, read a Report on the researches of M. Vicat, relative to resinous mastics.—General Brisbane communicated some Astronomical Observations made at Paramatta.—M. Dumeril made a Report on Dr. Audouard's Memoir relative to the origin of the yellow fever.—M. G. St.-Hilaire read a Memoir on the nature, the formation, and the uses of the stones which are found in the auditory cells of fishes.—M. Laugier finished the reading of his Memoir on the Ceylon Minerals.—M. Marigot communicated a Memoir on the preservation of grain.

July 5.—M. Fourier reported, verbally, on a collection of statistic documents presented to the Academy by the Count de Funchal.—M. Becquerel read a Memoir on the electromotive agencies of water.—M. A. St.-Hilaire read a Memoir on the plants constituting the Flora of southern Brazil, belonging to the group which comprises the Droseraceæ, the Violaceæ, the Cistinæ, and the Frankenæ.

July 12.—M. G. St.-Hilaire made a verbal Report on a work by M. Serres, entitled, "The comparative anatomy of the Brain, in the four classes of vertebrated Animals."—M. Gemmellaro, of Catania, presented a collection of maps and perspective views of Mount Etna.

July 19.—M. Freycinet communicated an extract from a Letter written to him from Port Jackson by M. Duperrey, commander

commander of the new circumnavigating expedition, containing an account of the recent discovery of a great river in New Holland; and stating the encouragement given to all useful researches by General Brisbane, correspondent of the Academy.—M. Arago presented, in the name of M. Zamboni, an electromotive apparatus founded on the properties of dry electric piles, and which imparts a continual rotatory motion to a horizontal lever.

LXIX. *Intelligence and Miscellaneous Articles.*

NORTHERN EXPEDITION.

ON Wednesday morning, Nov. 10, H. M. discovery-ship the *Griper*, Capt. G. F. Lyon, most unexpectedly arrived at Portsmouth, and ran into the harbour direct from Davis's Straits, with the signal of distress flying, having lost all her anchors and cables in fruitless endeavours to get into Repulse Bay, whither she was under orders to proceed, for the purpose of co-operating with Captain Parry in search of a north-west passage. The circumstances which have led to the failure of this branch of the north-west expedition are attributable to stormy and severe weather, which prevailed in a more intense degree than the oldest northern navigator remembers, and to the extraordinary bad qualities of the ship for the purposes required. It appears that the *Griper* left Stromness on the 1st of July, and made Cape Chudleigh (on the Labrador coast) on the 2d of August, having fallen in with icebergs three days previously, and from which time she was beset with drift ice. In this passage she was found to make so little progress, that the *Snap* (her provision tender) was frequently obliged to take her in tow. From Cape Chudleigh the *Griper* was obliged to stretch to the northward, to Resolution Island, as the field ice prevented progress up Hudson Strait, they were, however, enabled to make slow advances to the westward, close to the Savage Islands, until they made Salisbury or Nottingham Island, but which place could not be ascertained, from the impossibility of making observations off the Upper Savage Islands. Some canoes of natives came off to them, who appeared to be of the same description of Esquimaux with which our navigators were before acquainted. They were dismissed with liberal presents, and appeared much gratified. From Salisbury Island, the *Griper* proceeded to the south point of Southampton Island, in which they were assisted by a strong current setting down Fox's Channel; but on their rounding Southampton Island, this current, which then came down Sir Thomas

Rowe's

Rowe's Welcome (up which they wished to proceed), was directly against them, and nearly caused their shipwreck. Southampton Island was found to be laid down with tolerable accuracy. Off the S.W. end of the island the Griper was obliged to anchor, in consequence of suddenly shoaling her water: in a gale of wind she parted one anchor, but brought up again with three anchors a-head in quarter less four fathoms water; when the tide fell, the sea was so heavy that the rudder continually struck the ground, and was lifted almost out of the gudgeons: this was on the 1st of September. On the weather moderating, the Griper proceeded up the Welcome; but a northerly gale of wind springing up, the ship was driven into Hudson's Bay. However, by perseverance, and taking advantage of every favourable breeze of wind, she reached Cape Fullarton, the larboard entrance of Wager River, and within about 60 miles of the spot (Repulse Bay) where she was intended to winter. The coast on the American main land was found so rocky and extremely dangerous, that she was obliged to stretch off for Southampton Island, whence she endeavoured to make for Repulse Bay, but was driven by the tide directly to the southward and westward, against what was supposed to be Wager River. Here strong breezes and a heavy snow storm set-in, which made it necessary that the ship should be brought-to with three anchors a-head and made snug. The sea rose rapidly, and broke over the ship with tremendous force, forming thick coats of ice in an instant, so as to connect the shrouds together half way up the rigging. The snow also fell so fast that the men had much difficulty in keeping the decks clear. The ship all this time pitched so dreadfully, that the cables came over the bumpkins, one of which was thereby broken. During the night a large stream of ice was discovered coming down upon the ship, but, most happily, it parted before it reached her, and some small portions of it only struck against the bows, which did no damage. The wind continued to increase, as well as the snow; at five o'clock in the morning, the starboard cable parted, and, on the ship swinging to the other three anchors, she was struck by a sea and parted from them all. Her situation at this time was the most perilous that can be imagined, every individual momentarily expecting that she would drive on shore. Means of preservation, however, were not neglected; the trysails were got on her, though it was so dark that no object could be discerned, and they did not know so much as which way the ship's head lay, from the compasses having ceased to act, the ship being, as it is supposed, directly over or near the magnetic pole.—Whilst presuming, in this distressing dilemma,
that

that the wind had shifted off the land, as the water deepened, a sight of the sun, and subsequently of the other celestial bodies, was obtained (of which they had had no view for some days), and the ship was found to have been drifted out of the Welcome, after having attained lat. 65. 30. There was at this moment no anchor left in the ship. Notwithstanding, it was determined, if possible, to winter about Chesterfield Inlet, or even to the southward of that spot. The persevering efforts of all on board were accordingly directed to gain the American shore; but finding that the ship got into the shallows of Hudson's Bay, they were reluctantly compelled to edge away for Salisbury Island, still hoping that a few fine and favourable days would restore to them their lost ground. The bad weather, however, still continued, and there was much difficulty in watering the ship at these places, from a stream of ice. A number of natives came off to them in their canoes, and trafficked their clothes for iron and spears. At length the hopeless continuance of bad weather, the wretched condition of the ship (from her incapacities), the officers and crew having suffered more hardships than on any previous voyage, the advanced stage of the season, with numerous other concomitant miseries, compelled Captain Lyon to consent that the ship should be got out of Hudson's Straits (an extent of 800 miles of dangerous navigation); which place they had scarcely cleared, when a southerly gale drove them up Davis's Straits, 150 miles to the southward of Resolution Island. Providentially, a change of wind enabled them soon after to proceed on a southern passage homeward, and the Griper arrived here in six weeks, in the state we have described.

Though little has been effected towards solving the geographical problem of a north-west passage by this voyage, yet some most interesting elucidations of the deviation of the compass have been brought to light. The compasses began to waver and contradict each other when abreast of the Savage Islands; and, as the ship got to the westward, the compasses got unsteady and useless. While the ship was in Sir Thomas Rowe's Welcome, they frequently would not traverse at all, but stood in whatever position the card was placed. Should a passage be discovered by Captain Parry through the Prince Regent's Inlet, it is considered more than probable, from the irregular movement of the ice, that it may never be entered again.

The Griper spoke several whalers, all of which had been unsuccessful in the fishery; no ship had more than two fish, and many none whatever. From the captain of the Phoenix whaler, Captain Lyon heard that Captain Parry's expedition

had been seen in the middle of August, in lat. 71. beset with ice. On the whole the season has been more boisterous, and consequently the sea less clear, than it has been known for thirty years. It was very questionable if Captain Parry would be able to reach Lancaster Sound. Had the Griper effected a wintering either in Repulse Bay or Wager River, or Chesterfield Inlet, Captain Lyon, with a strong party, would have made a land journey to Point Turn-again, near the Copper Mine River, a distance of nearly 700 miles, for which expedition they were fully equipped. Captain Parry, if he succeeded in passing Lancaster Sound, and getting to the southward, down Prince Regent's Inlet (by which Captain Lyon was next year to communicate with him) he will send a land expedition, if possible, in the same direction, as well as to Repulse Bay, in the hope of communicating with the Griper.

The Griper communicated with the Esquimaux natives of the Upper Savage Islands, and of Salisbury and Nottingham Islands, all of whom had frequently seen Europeans. They were less savage in their habits and manners than their more northern brethren, but they showed a strong thievish disposition; they endeavoured to steal the oars and iron-work from the boats. The Griper also communicated with the natives of various parts of Southampton Island, who had never seen a ship before. They, however, expressed very little surprise; they evinced more gentleness in their manners than any other of the Esquimaux tribes, and were much better-looking and cleaner in their persons; the women were rather pretty. All those people reside in the Walrus-hide huts, which are described in Captain Lyon's last voyage.

The Griper is ordered to be paid off, and sold out of the navy. A vessel better adapted to the peculiarities of the service will no doubt be provided for Captain Lyon and his meritorious officers and crew, on the opening of the season for a further investigation. Captain Franklin, we understand, is to leave England, on his land expedition, in February next.—*Hampshire Telegraph.*

“THE LOGAN ROCK REPLACED.”

“Penzance, Nov. 6.

“The Logan rock is replaced, and rocks as before; it was put up on Tuesday last, after three days' labour, by the help of three pair of large sheers, six capstans, worked by eight men each, and a variety of pulleys. Large chain cables were fastened round the rock, and attached to the blocks by which it was lifted. Altogether there were about sixty men employed. The weight of the rock has been variously computed by

by different persons, at from 70 to 90 tons. On the first day, when the rock was first swung in the air, in the presence of about two thousand persons, much anxiety was felt by those who were present, as to the success of the undertaking; the ropes were much stretched; the pulleys, the sheers, and the capstans, all screeched and groaned; and the noise of the machinery was audible at some distance. Many were very apprehensive lest so vast a weight might snap all the ropes, and tumble over the precipice, bearing the sheers and scaffolding away with it; however, the whole has gone off with great success. The materials (which were all furnished *gratis*, from the dock-yard at Plymouth) were excellent, and ingeniously managed; and though a rope or two broke, and a link of one of the chains tore away a small piece of an angle of the rock, which was thrown with much velocity into the sea, yet the rock was safely supported by its complicated tackling, and stands, once more, in precisely its former position! Lieutenant Goldsmith, who threw it down, was the engineer in replacing it; and, in the opinion of many of the gentlemen of this town and neighbourhood, he has, by his skill and personal labour and attention, not only wiped away the disgrace to which he was exposed by throwing it down, but also acquired so much merit, that they are about to invite him to a public dinner at Pearce's Hotel. This seems to be going a little too far; since whatever credit he may have derived by replacing the rock, seems to be fully counterbalanced by the discredit of its wanton demolition. It is understood that the expenses of this work are defrayed by subscription. Fifty pounds have been given by the London Geological Society."—*Morn. Chron.*

ACCOUNT OF THE TRONA LAKE IN AFRICA.

The following account of this remarkable soda-lake is given by Dr. Oudney, in a letter to Professor Jameson.

"The Trona Lake is situated in the midst of amazingly high sand-hills, that run for several hundred miles to the westward, and lie between Wadies Shiati and Ghrurbi. It is in a small valley which runs nearly ESE. and WNW. The north and south sides are bounded by hills of sand about 400 feet high. The bottom is a fine sand, on which are found the Agoul (apparently a species of *Ulex*), and a downy grass. Near where we entered the valley, there is a cluster of date-palms, and a small lake, from which impure trona is obtained. On the western side is the trona lake, surrounded by date-trees, and its banks and marshy borders covered, on almost all sides, by the grass I have mentioned, and a tall juncus. It is about half a mile long, and nearly 200 yards wide, of very inconsi-

derable depth at present (July), from the evaporation of the water, and many places are dry now which are covered in the winter and spring. The trona is deposited in cakes at the bottom of the lake, when the saturation is at a certain extent. The cakes are of various degrees of thickness, from the finest film to several inches. The thickest I could find was not more than $\frac{3}{4}$ ths of an inch; but at the beginning of winter, when the water begins to increase, it is of the thickness I have mentioned, and it is then said to be ripe. The surface next the earth is not unequal from crystallization, but rough to the feel with numerous rounded asperities. That next the water is generally found studded with small beautiful cubical crystals of muriate of soda; the line of junction is always distinct, and the one is easily removed from the other. The upper surface, when not covered with the muriate, is composed of a congeries of small tabular pieces, joined in every position; when the mass is broken, there is a fine display of acicular crystals, often radiated. The surface of the water is covered in many places with large thin sheets of a carbo-muriate of soda, giving the whole the appearance of a lake partially frozen over: film after film forms, till the whole gets of considerable thickness. The soil of the lake is a dark brown sand, approaching to black, of a viscid consistence, and slimy smell, and on the lately uncovered surface, near the banks, a black substance, like mineral tar, is seen oozing out.

The water begins to increase in the winter, and in the spring it is at the maximum. The trona is best about the commencement of winter, but disappears entirely in the spring.

The lake has diminished considerably in size within the last few years, and if care be not taken, the diminution will soon be much greater: plants are making rapid encroachments, and very shallow banks are observable in many places. On inquiry, we found the quantity of trona had not sensibly diminished for the last ten years; perhaps it may appear so, from there always being sufficient to answer every demand. The quantity annually exported amounts to between 400 and 500 camel-loads, each equal to about 4 cwt.—a large quantity, when the size of the lake is considered. It is removed only when a demand comes; then a man wades in, breaks it off in large sheets, which he easily does; hands it to others outside, who are ready to remove all foreign matters, and pack it in the setose bases of the palm-leaves. The water in the valley is good, and if a well be dug on the very border of the lake, the water is also good, and sensibly free from saline impregnation."

DISCOVERY OF FOSSIL BONES AT BANWELL.

An immense assemblage of fossil bones has recently been discovered in Somersetshire, in a cavern of the Limestone Rock at Banwell, near the west extremity of the Mendip Hills, on the property of the Bishop of Bath and Wells. The circumstances which led to this discovery are as follow:—Some miners engaged in sinking a shaft in search of calamine, intersected a steep and narrow fissure, which, after descending 80 feet, opened into a spacious cavern, 150 feet long and about 30 feet wide, and from 20 to 30 feet high. From the difficulty of descending by this fissure, it was lately judged desirable to make an opening in the side of the hill a little below, in a line which might lead directly to the interior of the cave. This gallery had been conducted but a few feet, when the workmen suddenly penetrated another cavern of inferior dimensions to that which they were in search of, and found its floor to be covered, to a depth which has not yet been ascertained, with a bed of sand, mud, and fragments of limestone, through which were dispersed an enormous quantity of bones, horns, and teeth. The thickness of this mass has been ascertained, by a shaft sunk into it, to be in one place nearly 40 feet. Many large baskets full of bones have already been extracted, belonging chiefly to the ox and deer tribes; of the latter there are several varieties, including the elk. There are also a few portions of the skeleton of a wolf, and of a gigantic bear. The bones are mostly in a state of preservation equal to that of common grave bones, although it is clear, from the fact of some of them belonging to the great extinct species of bear, that they are of antediluvian origin.

In the roof of the cave there is a large chimney-like opening, which appears to have communicated formerly with the surface; but which is choked up with fragments of limestone, interspersed with mud and sand, and adhering together imperfectly by a stalagmitic incrustation. Through this aperture it is probable the animals fell into the cave, and perished in the period preceding the inundation by which it was filled up. The immense quantity of the bones shows the number of individuals that were lost in this natural pitfall to have been very great. In this manner cattle are now continually lost by falling into similar apertures in the limestone hills of Derbyshire.

There is nothing to induce a belief that it was a den inhabited by hyænas, like the cave of Kirkdale, or by bears, like those in Germany; its leading circumstances are similar to those of the ossiferous cavities in the Limestone Rock at Oreston near Plymouth.

The cave at Banwell has within these few days been examined

mined by Professor Buckland, and operations have been commenced for the purpose of thoroughly investigating its history and contents. The Bishop has already sent collections of the bones to the museums of Oxford and Cambridge, and intends to provide a similar supply for all the principal public institutions in this country.

ORGANIC REMAINS IN SUSSEX.

The workmen employed in forming the tunnel under the road at Kemp-town, near Brighton, discovered numerous teeth and bones, which were at first supposed to be part of human skeletons, but, upon being examined by a gentleman conversant with such subjects, were ascertained to belong to the horse and elephant. Similar organic remains are commonly found in diluvial beds, like that on which Brighton is situated, and are evidently the remains of those land animals which were destroyed by the deluge. The town is built upon an accumulation of water-worn materials, which fill up a valley of the chalk. A short time since, a rib of a very large animal, supposed to be that of an elephant, was discovered in the bank on the west side of Shoreham harbour. Mr. Mantell has discovered in the iron-sandstone of this county, the teeth of an herbivorous reptile of a gigantic magnitude. This animal approaches nearer to the Iguana of Barbadoes, than to any other recent lizard, and it is proposed to distinguish it by the name of *Iguano-saurus*. Detached parts of the skeleton, as vertebræ, thigh-bones, &c. have also been found, of which a particular account will be laid before the scientific public. Mr. Mantell has part of a thigh-bone in his possession, which there is every reason to conclude is referable to this animal; its size is so great, that upon a moderate computation, the individual to which it belonged must have equalled the elephant in height, and been upwards of 60 feet long.—*Sussex Advertiser*.

CABINET OF MINERALS AT CAMBRIDGE (UNITED STATES).

The liberality of several gentlemen of Boston, and their desire to promote the study of Mineralogy and Geology in this vicinity, have lately been displayed in the purchase of an extensive and valuable collection of minerals, which they have presented to the University at Cambridge.

This collection is now added to that presented by Andrew Ritchie, Esq. and, together with the specimens formerly transmitted by the French Government and the late Dr. Lettsom, with the additions made by Dr. Waterhouse, will constitute one of the most complete and valuable mineralogical cabinets in the United States.

The

The collection embraces (with the exception of a *very few* of the rarest substances) all the late discoveries, and many of those specimens the localities of which are exhausted, and many of which are now rarely met with even in the large collections of Europe. The suite of Ores is peculiarly rich, as is likewise the volcanic department; and the gems and precious stones are numerous. The specimens are all well characterized, and the crystallizations are remarkably fine.

This collection is arranged in the spacious room formerly used as the Commons Hall, being $45\frac{1}{2}$ feet in length, $36\frac{1}{2}$ feet wide, and $17\frac{2}{3}$ feet high.

The specimens are placed in cases with glass doors against the walls of the room, which to the height of ten feet are completely covered by them; a large proportion of the most beautiful specimens are arranged upon eight glazed tables, and the residue in nearly 200 drawers.

One of the tables is appropriated to the **EXTERNAL CHARACTERS** of mineral substances, on which are disposed the most distinctly characterized specimens, illustrating all the technical terms of the science, the different varieties of colour, of fracture, lustre, transparency, hardness, &c. &c. To these succeed the most perfect crystals illustrating the primary forms of Werner and Häuy, the modifications of these forms, and the effect of truncations, bevelments, &c.—A suite of models of crystals, in wood, terminates this first division of the cabinet.

The second division is the systematic arrangement of the different substances according to their chemical composition; this method has been adopted, as it is intended to combine the instruction in chemistry with mineralogy.

The third division comprises the Geological part of the collection, in which the rocks are arranged in the relative order in which they are presented to us by nature, and in connexion with each are seen the minerals composing the rock, and those which are more or less accidentally present in it, together with the metallic ores and fossil remains.

The fourth division is Geographical, commencing with the mineral productions of the United States, arranged according to States.

The last division is intended to embrace all the products of the Mineral kingdom employed in the arts and manufactures, in their natural state, and in the different stages of preparation. This department is one of peculiar interest and importance in this country, and can only be rendered complete by the liberality of artists and manufacturers, who, it is hoped, will not be backward to transmit to the University such specimens as will best illustrate the different stages of all the processes connected

nected with each substance. Thus, here will be seen the different ores, as when first taken from the earth, and the same in all the degrees of purification, &c.—the clays in all the stages of manufacture—the substances used in colouring, in the manufacture of glass, &c. &c.

Mineralogists throughout the country, it is hoped, will avail themselves of the permission granted by the Corporation of the University to exchange duplicate specimens.—*Boston Journal of Philosophy.*

ON METALLIC TITANIUM.

Dr. Walckner of Freyberg, in the Breisgaw, has lately described cubical crystals of metallic titanium which he observed in iron-slugs from the Upperland of Baden. The slug was from a furnace where pea-ore (*bohnerz*) was smelted, and analysis proved that this ore of iron contained a minute portion of titanium. Dr. Wollaston*, as is well known, was the first who described these cubes. They occur in the slags of iron forges in Wales, in those at Bradford in Yorkshire, Alfreton in Derbyshire, at Pontypool in Monmouthshire, in Clydesdale in this country, and we have no doubt will be met with in many other places where our common iron-ores are smelted.—*Edin. Phil. Journ.* vol. xi. p. 411.

PROF. BERZELIUS ON SILICIUM AND ZIRCONIUM.

In trying to reduce fluoric acid by potassium, I succeeded in reducing silica, zirconia, and the other earths; but I have only been able to separate silicium and zirconium. The others decompose water with the greatest energy. Pure silicium is incombustible even in oxygen gas. Water, nitric acid, or nitro-muriatic acid, do not attack it, nor does caustic potash; but fluoric acid dissolves it a little, especially if nitric acid be added. It does not decompose nitre, except at a very intense heat, but it detonates with carbonate of potash at a dull red heat; carbonic oxide gas is liberated, and carbon is set at liberty. When it is heated with nitre, if a small piece of dry carbonate of soda is introduced into the mixture, there is immediate detonation. When the vapour of sulphur is passed over silicium heated to redness, the metal quickly becomes incandescent. When the combination is perfect, which seldom happens, the substance is in the form of a white earthy mass, and decomposes water with great rapidity. The silica is dissolved, and sulphuretted hydrogen gas liberated. By this means a solution of silica in water may be obtained,

* See *Phil. Mag.* vol. lxii. p. 18; lxiii. p. 15.

hydrocyanic acid by the action of nitric acid and charcoal*. M. Frisiani has also observed the same effect produced, in a very striking manner, during the action of nitric acid on the residuum obtained by calcining sulphate of baryta with vegetable charcoal, and removing every thing soluble in water by repeated washings. A strong odour of hydrocyanic acid was produced, and when the action was made to take place in a Woulfe's bottle, the liquor collected, when rendered slightly acid, and precipitated by persulphate of iron, gave a precipitate, which washed with muriatic acid became Prussian blue. Nitrates of the earths, or alkalies, boiled with vegetable charcoal, gave no result of this kind. When the nitrates and charcoal were mixed in the dry way and heated, the action was, of course, violent, but no important results were obtained.—*Gio. de Fis.* vii. 240.

ANALYSIS OF THE HOLY-WELL WATER, NEAR CARTMELL, LAN-
CASHIRE.—BY J. C. WOOLNOTH, LIEUT. R.N.

This spring is situated at the base of a bluff hill called Humphrey Head, the extreme point of a range of calcareous hills forming the eastern boundary of the Vale of Cartmell. The water is emitted through a small lead tube about an inch in diameter, surrounded and inclosed by rough masonry, and which delivers a gallon of water in about 1' 47". The specific gravity of the water is 1.006, and the relative proportions of its contents appear, from various experiments, to be as follows, in a wine pint of the water:—

Carbonic acid gas	one cubic inch.
Carbonate of magnesia	0.266
Sulphate of soda	3.872
———— lime	1.500
———— magnesia	3.000
Muriate of soda	19.782
———— magnesia	9.000
Peroxide of iron	1.750
Insoluble in muriatic acid, princi- } pally silica }	3.000

42.170 grains.—

Journal of Sciences, &c. vol. xviii. p. 187.

MR. D. GILBERT ON THE WHEELS AND SPRINGS OF CARRIAGES.

Taking wheels completely in the abstract, they must be considered as answering two different purposes.

First, They transfer the friction which would take place be-

* See *Phil. Mag.* vol. lxii. p. 153, 234.

tween a sliding body and the comparatively rough uneven surface over which it slides, to the smooth oiled peripheries of the axis and box, where the absolute quantity of the friction as opposing resistance is also diminished by leverage, in the proportion of the wheel to that of the axis.

Secondly, They procure mechanical advantage for overcoming obstacles in proportion to the square roots of their diameters when the obstacles are relatively small, by increasing the time in that ratio, during which the wheel ascends: and they pass over small transverse ruts, hollows, or pits, with an absolute advantage of not sinking, proportionate to their diameters, and with a mechanical one as before, proportionate to the square roots of their diameters.

Consequently, wheels thus considered cannot be too large: in practice, however, they are limited by weight, by expense, and by convenience.

With reference to the preservation of roads, wheels should be made wide, and so constructed as to allow of the whole breadth bearing at once; and every portion in contact with the ground should roll on it without the least dragging or slide: but it is evident, from the well-known properties of the cycloid, that the above conditions cannot unite, unless the roads are perfectly hard, smooth, and flat; and, unless the felines of the wheels, with their tires, are accurately portions of a cylinder. These forms, therefore, of roads and of wheels, are the models towards which they should always approximate.

Roads were heretofore made with a transverse curvature to throw off water, and in that case it seems evident that the peripheries of the wheels should in their transverse sections become tangents to this curve, from whence arose the necessity for dishing wheels, and for bending the axes; which contrivances gave some incidental advantage for turning, for protecting the nave, and by affording room for increased stowage above. But recent experience having proved that the curved form of roads is wholly inadequate for obtaining the end proposed, since the smallest rut intercepts the lateral flow of the water; and, that the barrel-shape confines carriages to the middle of the way, and thereby occasions these very ruts,—roads are now laid flat, carriages drive indifferently over every part, the wear is uniform, and not even the appearance of a longitudinal furrow is to be seen. It may, therefore, confidently be hoped, that wheels approaching to the cylindrical form will soon find their way into general use.

The line of traction is mechanically best disposed when it lies exactly parallel to the direction of motion, and its power is diminished at any inclination of that line in the proportions

of the cosine of the angle to radius. When obstacles frequently occur, it had better perhaps receive a small inclination upwards, for the purpose of acting with most advantage when those are to be overcome. But it is probable that different animals exert their strengths most advantageously in different directions, and therefore practice alone can determine what precise inclination of this line is best adapted to horses, and what to oxen. These considerations are, however, only applicable to cattle drawing immediately at the carriage; and the convenience of this draft, as connected with the insertion of the line of traction, which continued ought to pass through the axis of the wheels, introduces another limit to their size.

Springs were in all likelihood applied at first to carriages, with no other view than to accommodate travellers. They have since been found to answer several important ends.

They convert all percussion into mere increase of pressure,—that is, the collision of two hard bodies is changed by the interposition of one that is elastic, into a mere accession of weight. Thus the carriage is preserved from injury, and the materials of the road are not broken: and, in surmounting obstacles, instead of the whole carriage with its load being lifted over, the springs allow the wheels to rise, while the weights suspended upon them are scarcely moved from their horizontal level. So that, if the whole of the weight could be supported on the springs, and all the other parts supposed to be devoid of inertia, while the springs themselves were very long, and extremely flexible, this consequence would clearly follow, however much it may wear the appearance of a paradox;—that such a carriage may be drawn over a road abounding in small obstacles without agitation, and without any material addition being made to the moving power or draft. It seems, therefore, probable that, under certain modifications of form and material, springs may be applied with advantage to the very heaviest waggons; and consequently, if any fiscal regulations exist either in regard to the public revenue or to local taxation, tending to discourage the use of springs, they should forthwith be removed.

Although the smoothness of roads and the application of springs are beneficial to all carriages and to all rates of travelling, yet they are eminently so in cases of swift conveyance, since obstacles when springs are not interposed, require an additional force to surmount them beyond the regular draft, equal to the weight of the load multiplied by the sine of the angle intercepted on the periphery of the wheel between the points in contact with the ground and with the obstacle, and therefore proportionate to the square of its height; and a still further

further force, many times greater than the former when the velocity is considerable, to overcome the inertia; and this increases with the height of the obstacle, and with the rapidity of the motion, both squared. But, when springs are used, this latter part, by far the most important, almost entirely disappears, and their beneficial effects in obviating the injuries of percussion are proportionate also to the velocities squared.

The advantages consequent to the draft from suspending heavy baggage on the springs, were first generally perceived about 40 years since, on the introduction of mail-coaches; then baskets and boots were removed, and their contents were heaped on the top of the carriage. The accidental circumstance, however, of the weight being thus placed at a considerable elevation, gave occasion to a prejudice, the cause of innumerable accidents, and which has not, up to the present time, entirely lost its influence; yet, a moment's consideration must be sufficient to convince any one, that when the body of a carriage is attached to certain given points, no other effect can possibly be produced by raising or by depressing the weights within it, than to create a greater or a less tendency to overturn.

The extensive use of waggons suspended on springs, for conveying heavy articles, introduced within these two or three last years, will form an epoch in the history of internal land communication, not much inferior perhaps in importance to that when mail-coaches were first adopted; and the extension of vans in so short a time to places the most remote from the metropolis, induces a hope and expectation, that as roads improve, the means of preserving them will improve also, possibly in an equal degree, so that permanence and consequent cheapness, in addition to facility of conveyance, will be distinguished features of the M^cAdam system.—*Journal of Science*, vol. xviii. p. 95.

Calendar of Flora, Fauna, and Pomona, at Hartfield in Sussex, continued from October 27 to November 21.

Oct. 27.—A few swallows seen; they were only stragglers, and appeared like the young of a late brood. To see these birds on the vigil of St. Simon and Jude is recorded as being a very unusual phænomenon. A martin or two has sometimes been seen so late as November, but the *Hirundo rustica* is very rarely seen after the middle of the month of October.

Oct. 29.—The yellow and red decaying leaves are fast falling. The weather wet and variable.

Nov. 1.—All-saints Day. Many plants remain in flower, here
and

and there; as Marigolds, Stocks, the Leopard's-bane, Michaelmas Daisy, *Aster Tradescantii*, the *Aster tardiflorus*, and others.

Nov. 2.—All-souls Day. The large or Gansel's Bergamot Pears ripe, but not very good this year. The Geraniums and Myrtles still flourish out of doors. Polyanthuses and Daisies are in flower, and a few of the common Primrose. There is also an abundance of Chinese Roses.

Nov. 11.—The Swan's Eggs and the Crasane Pears ripe, and of very good flavour this year.

Nov. 13.—It is observed that most of the Apples in the loft keep very badly this year, beginning to rot much sooner than usual: they are likewise infested with a small worm, which leaves round black foramina in them. The sort called Red-streaks and Duckbills keep the worst. The crops of this fruit have been very scanty, and the price of them is advancing.

Nov. 20.—Weather very wet, and the marshes flooded. Large congregations of rooks and daws, sometimes accompanied by starlings, begin to be frequent, as is usual in autumn. The European Tailpye, *Mecistura vagans*, has several times appeared of late in small flocks, wandering over the country at uncertain intervals, and performing partial migrations.

Nov. 21.—Weather warm and showery, and the ground unusually wet, with a flood in the marshes of the Medway. While sitting at tea, we were surprised by a sharp, sudden, and unusually loud clap of thunder, followed by a violent storm: it did not clear the air, as we at first hoped, but has ended again in settled rain, while the floods in the meadows continue to increase.

T. FORSTER.

LIST OF NEW PATENTS.

To Joseph Apsden, of Leeds, Yorkshire, bricklayer, for his improvement in the modes of producing an artificial stone.—Dated 21st October, 1824.—2 months allowed to enrol specification.

To George Dodd, of St. Anne-street, Westminster, Middlesex, engineer, for certain improvements on fire-extinguishing machinery.—21st October.—6 months.

To George Samuel Harris, of Caroline-place, Trevor-square, Knights-bridge, Middlesex, gentleman, for his machine for the purpose of giving the most effectual and extensive publicity, by day and by night, to all proclamations, notices, legal advertisements, and other purposes to which the same may be applicable, destined for universal information, and which will henceforward render unnecessary the defacement of walls and houses in the metropolis and its vicinity by bill-sticking, placarding, and chalking, which latter practices have become a great and offensive public nuisance.—21st October.—2 months.

To John Lingford, of Nottingham, lace-machine manufacturer, for certain improvements upon machines or machinery now in use for the purpose of

of making that kind of lace commonly known or distinguished by the name of bobbin, net, or Buckinghamshire lace-net.—1st November.—6 months.

To The Rev. John Somerville, A.M. minister of the parish of Currie, Edinburgh, for a method or methods applicable to fowling-pieces or other fire-arms, by which method or methods all accidental discharge of such fowling-pieces or other fire-arms will be completely prevented.—4th November.—2 months.

To John Crosley, of Cottage-lane, City Road, Middlesex, gentleman, for his contrivance for better ensuring the egress of smoke and rarefied air in certain situations.—4th November.—6 months.

To Thomas Richard Guppy, of Bristol, gentleman, for certain improvements in masting vessels.—4th November.—6 months.

To John Head, of Banbury, Oxfordshire, hosier, for certain improvements in machinery for making cords or plait for boot and stay laces, and other purposes.—4th November.—4 months.

To William Church, of Birmingham, Warwickshire, esquire, for certain improvements on augers and bits for boring, and in the apparatus for making the same.—4th November.—6 months.

To William Busk, of Broad street, London, esquire, for certain improvements in propelling ships, boats, or other vessels or floating bodies.—4th November.—6 months.

To John White the younger, and Thomas Sowerby, both of Bishop Wearmouth, Durham, merchants, for their improved air-furnace for the purpose of melting or fusing metallic substances.—6th November.—4 months.

To John Moore, of Broad Weir, Bristol, gentleman, for certain additions to an improvement upon the steam-engine or steam-engine apparatus.—6th November.—6 months.

To Thomas Cartmell, of Doncaster, Yorkshire, gun-maker, for an improved cock to be applied to the lock of any gun, pistol, fire-arms, or ordnance, for the purpose of firing the same by percussion, acting either by self-priming or otherwise, and whereby the priming is rendered wholly impervious alike to the wind, rain, or damp.—6th November.—2 months.

To Charles Heathorn, of Maidstone, Kent, lime-burner, for his method of constructing and erecting a furnace or furnaces, kiln or kilns, for the more speedy, more effectually, and more economically manufacturing of lime, by means of applying, directing, and limiting, or regulating the flame and heat arising in the manufacturing or burning coal into coke, and thus making lime and coke in one and the same building, and at one and the same time.—11th November.—2 months.

To William Leathy, of Great Guildford-street, Borough of Southwark, engineer, for various improvements in the machinery or apparatus used in the making of bricks, and certain improvements in the drying of bricks, by means of flues and steam.—11th November.—6 months.

To Pierre Brunet, of Wimpole-street, Cavendish-square, Middlesex, merchant, who, in consequence of a communication made to him by a certain foreigner residing abroad, with whom he is connected, is in possession of an invention of a furnace made upon a new construction.—11th November.—6 months.

To Joseph Clisild Daniell, of Stoke, Wilts, clothier, for certain improvements in dressing woollen cloth.—20th November.—4 months.

To Isaac Taylor junior, of Chipping Ongar, Essex, gentleman, for a newly invented cock or tap for drawing off liquids.—20th November.—2 months.

To William Rhodes, of Baulins, Hoxton, Middlesex, brick-maker, for his improvement in the construction of clamps for burning raw bricks.—20th November.—6 months.

A METEOROLOGICAL TABLE: comprising the Observations of Dr. BURNEY at Gosport, Mr. CARY in London, and Mr. VELL at Boston.

GOSPORT, at half-past Eight o'Clock, A.M.		CLOUDS.										Height of Barometer, in Inches, &c.			Thermometer.			RAIN.		WEATHER.		
		Barom. in Inches, &c.	Thermo.	Temp. of Sp. Water.	Hygrom.	Wind.	Evapora- tion.	Rain near the Ground	Cirrus.	Citrocum.	Citrostr.	Stratus.	Cumulus.	Cumulostr.	Nimbus.	Land. 1 P.M.	Bost. 8 1/2 A.M.	London. 11 P.M.	Boston. 8 1/2 A.M.	London.	Boston.	
Oct. 26	29.34	56	53.40	72	S.W.	0.20	0.045	1	1	1	1	1	1	1	29.30	28.90	55.56	47	52	...	Stormy	Rain
27	29.52	52	...	63	W.	0.20	.020	1	1	1	1	1	1	1	29.60	29.13	47.56	50	47	...	Fair	Fine
28	29.69	54	...	73	S.W.415	1	1	1	1	1	1	1	29.76	29.35	49.57	50	51	...	Rain	Fine, rain a.m.
29	29.67	54	...	77	E.020	1	1	1	1	1	1	1	29.65	29.50	50.52	50	43	...	Fair	Cloudy, rain a.m.
30	29.90	46	...	70	N.W.010	1	1	1	1	1	1	1	30.05	29.60	43.48	43	39	...	Fair	Rain [and p.m.]
31	30.00	53	...	72	W.	.25	.040	29.90	29.83	45.49	45	39.5	...	Rain	Rain
Nov. 1	29.69	52	53.00	74	W.	29.65	29.40	50.55	55	46.5	0.05	Cloudy	Rain
2	29.80	57	...	74	W.	29.58	29.34	54.58	47	50	...	Cloudy	Rain, stormy a.m.
3	29.88	48	...	70	W.	.24	.010	1	1	1	1	1	1	1	29.85	29.50	42.50	42	43.5	...	Fair	Rain, rain at nt.
4	29.84	45	...	67	N.W.020	1	1	1	1	1	1	1	29.85	29.50	40.47	40	37	...	Fair	Fine
5	29.73	45	...	73	N.W.	29.84	29.55	40.46	35	37	...	Fair	Fine
6	30.02	39	...	67	N.E.	.21	.005	1	1	1	1	1	1	1	30.12	29.90	32.45	46	32	...	Fair	Fine, rain at night.
7	29.98	56	53.00	71	S.W.010	1	1	1	1	1	1	1	29.99	29.70	51.56	50	51	...	Cloudy	Cloudy
8	29.70	56	...	72	S.W.	.20	.055	1	1	1	1	1	1	1	29.61	29.45	50.57	47	50.5	0.06	Cloudy	Cloudy, heavy rain
9	29.95	43	...	74	N.W.080	1	1	1	1	1	1	1	30.03	29.65	40.50	50	39	...	Fair	Fine [p.m.]
10	29.95	56	...	72	W.170	29.83	29.50	55.55	56	55	...	Cloudy	Cloudy
11	29.88	57	...	73	W.	.20	.020	1	1	1	1	1	1	1	29.85	29.50	55.55	50	51	...	Rain	Cloudy
12	30.00	46	...	72	W.	30.10	29.63	40.47	45	44	...	Fair	Fine, rain a.m.
13	30.10	51	...	71	W.155	1	1	1	1	1	1	1	29.90	29.75	45.52	47	44	...	Cloudy	Cloudy
14	29.60	55	52.90	79.	W.	.25	.210	29.55	29.15	45.47	47	50.5	...	Rain	Stormy
15	29.93	43	...	71	W.015	1	1	1	1	1	1	1	29.98	29.60	40.47	55	39.5	1.40	Fair	Fine
16	30.19	42	...	68	S.E.405	1	1	1	1	1	1	1	30.17	29.95	34.47	52	35	...	Cloudy	Cloudy
17	29.84	52	...	68	S.360	29.70	29.45	50.52	55	51.5	...	Cloudy	Stormy
18	29.45	58	...	76	S.W.	.20	.360	29.52	28.93	55.52	45	57	...	Stormy	Stormy
19	29.73	50	53.00	73	S.715	29.69	29.55	45.50	46	40	...	Rain	Fine, rain p.m.
20	29.40	49	...	78	E.395	1	1	1	1	1	1	1	29.37	29.40	43.50	50	38	...	Rain	Rain
21	29.41	52	...	76	W.	.25	.380	1	1	1	1	1	1	1	29.45	29.20	50.54	50	44	...	Fair	Fine
22	29.40	44	...	74	W.490	1	1	1	1	1	1	1	29.40	28.90	42.48	48	41	1.22	Fair	Rain [rain a.m.]
23	28.47	52	...	69	S.280	28.52	28.30	47.47	42	49	...	Stormy	Stormy, Wind S.E.
24	29.00	48	...	65	W.	29.07	28.60	40.47	40	44	...	Fair	Cloudy, wind West.
25	29.28	46	52.95	68	N.W.	.30	29.50	29.10	39.46	38	41.5	...	Cloudy	Fine, rain early a.m.

INE

*Liquids
which take
Metals,
rien Chef*



smallest
ric phæ-
instant
h other.
e had to
nstances
e means
it one of
omenon,
ore sen-
it.
electro-
pts were
enough;
suitable.
d of pa-
ed some
did not
s; after
electricity
with the

nd that
od sup-
which

5.

. Rous-

Fig. 1.



Fig. 3.



Fig. 7.



Fig. 4.



Fig. 8.



Fig. 5.



Fig. 2.



Fig. 6. a

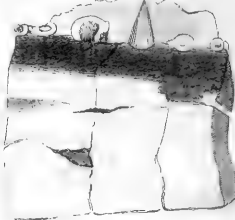

THE
PHILOSOPHICAL MAGAZINE
AND JOURNAL.

31st · D E C E M B E R 1824.

LXX. *On the Electro-motive Actions of Water and Liquids in general on Metals : and of the electric Effects which take place—first, in the Contact of certain Flames and Metals, secondly, in Combustion.* By M. BECQUEREL, *Ancien Chef de Bataillon du Génie.**

Electro-motive Actions of Water on Metals.

WE have formerly been occupied in reducing to the smallest possible number the causes which produce electric phænomena, whether in the contact of bodies, or at the instant when these bodies enter into combination with each other. Constantly guided by this view of the subject, we have had to submit to experiment, simple bodies, as much as circumstances would permit. Researches of this kind require that the means of experiment be continually modified; for as we quit one of the causes which concurs to the production of a phænomenon, we often diminish its intensity to such a point that a more sensible apparatus is then necessary, in order to observe it.

For some time we had sought to determine the electro-motive action of water on a metal; but our first attempts were not satisfactory: first, the condenser had not sensibility enough; and lastly, the mode of experiment itself was not suitable. We placed on the upper plate of the condenser a band of paper, and above the vessel of metal into which we poured some water. We found afterwards that this band of paper did not prevent electro-motive actions between it and the metals; after that, it became impossible to collect the very weak electricity which the vessel of metal acquired during its contact with the water.

We subsequently recollected that Coulomb had found that electricity escaped very rapidly by the glass and wood supporters, when they were slightly damp; a property which

* From the *Annales de Chimie et de Physique*, tom. xxvii. p. 5.

M. Rousseau has of late fully illustrated, by showing, with an electrometer of his invention, that all badly conducting bodies, covered with a thin stratum of hygrometric water, conducted with facility very small quantities of electricity. We therefore took a little capsule of wood or porcelain, filled with distilled water; and after having slightly moistened its sides, we placed it on the upper plate of the condenser. But as this box sometimes exercises an electro-motive action, very feeble indeed, on the plate, that is destroyed by touching the lower plate with a capsule formed of the same matter. The precaution may even be pushed so far as to fill it with distilled water; then, touching this water with the finger, account is kept on each side of the action of the water on the wood. Laminæ of different metals held between the fingers were plunged in one of the two capsules, taking the precaution of not touching the sides; the other plate was in communication with the earth. Zinc, iron, lead, tin, copper, &c., communicated to it positive electricity; whilst platinum, gold, silver, &c., gave it negative electricity. Water then is positive with the metals which are the most positive, and negative with those which are the least so. It thus exhibits the same effects with the oxidable metals as alkalies do in their contact with acids, when there is no chemical action.

These phænomena also take place when the water contains a small quantity of sulphuric acid. It may be remarked, that the water is then decomposed by the iron and the zinc, and that these metals are attacked. The chemical action in this case has not therefore hindered the production of the electric phænomena which result from the contact of the metals with the water.

These experiments require great precautions. It is necessary that the surface of each metal be perfectly freed from rust, or well polished, not with emery paper, but with pounded glass, in order to remove any grains of emery from their surfaces, which might there exercise electro-motive effects. It is also preferable to use a wooden capsule slightly moistened, because its fibres, being impregnated with moisture, conduct the electric fluid with more facility than glass or porcelain. Notwithstanding these precautions, it sometimes occurs that no result is obtained; but when these phænomena are produced, it is always in the order we have just mentioned.

Perhaps we might be led to think that the small quantities of electricity, which often remain attached to the light coat of varnish with which each plate of the condenser is covered, disturb the results by their presence, and lead to error, especially

especially in the experiments in which the development of electricity is feeble. But this is not the case; for the precautions we take secure us from such effects. Before the commencement of an experiment, we assure ourselves by several trials that the plates retain no electricity: when we find any, we have them heated sufficiently to drive it away, or else we place, as M. Pouillet does, a disk of tin between the two plates; then the small quantities of electricity which remain on the surface of the layers of varnish become combined by its intervention. Afterwards, we employ successively, as a collector, each of these two plates, both being adapted to receive a capsule. If a different electricity is then obtained, it is a proof that the experiment has succeeded, the disturbing causes being removed. Besides, the laws to which the greater part of the results are submitted, come still further in aid of the exactness of the experiments.

We have also another objection to obviate. When a capsule of earthenware, glass, &c., is placed on one of the plates of the condenser, and is touched with the finger,—which, as is well known, is not a good conductor,—the condenser does not become charged. It may be thought, that in touching the water which it contains with any metal which is an excellent conductor, the discharge of the electricity supposed to be acquired by the capsule, in its contact with the plate, ought to be more rapid, and that the condenser should become charged: but this does not take place; for all the metals ought to give the same electricity in their contact with the water, which is not the case. Finally, by holding the metal between the fingers, the conductivity is only momentarily augmented; since the electricity, after having traversed the metal, is obliged to pass afresh through the hand, where it finds the same obstacles as when the finger touched the liquid. It is, therefore, now well proved, that we have really observed the electro-motive actions of water on metals.

These actions being found, we then inquired if their intensity was not susceptible of augmentation or diminution, according to the modifications which the surfaces of metals might experience in certain circumstances. A plate of gold was plunged into nitric acid for some moments, and then washed several times in water; it was then put in contact with the water of the wooden capsule: the result was a development of electricity much more considerable than before; the water again took the negative electricity.

The same plate plunged afresh into a solution of potash, lost in great part the property of acquiring electricity by the contact

of water. A plate of platinum exhibited absolutely the same results. May not these phænomena have some distant relation to those observed by MM. Thenard and Dulong in their researches respecting the property which certain bodies possess of favouring the combination of elastic fluids? These two celebrated philosophers found that a fresh wire of platinum, which did not become heated at the ordinary temperature, when it was placed under a current of hydrogen gas, which diffused itself in the air, became susceptible of becoming red-hot, when it had previously been plunged in nitric acid for some minutes, and the excess of acid taken away. The property that the platinum wire then acquires, lasts more than twenty-four hours. We remarked that a plate of gold preserved for several hours the property of becoming strongly electric in its contact with the water.—We propose to return to these phænomena, which we only indicate here.

Electric Effects observed in the Contact of two Metals with a Liquid.

We have already said, that the electric effects which manifested themselves when two metals were separated by a liquid, were not similar to those which took place when the liquid was replaced by any metal; for Volta found that, in this last case, the intermediate metal served only as a conductor; whereas we have shown that this did not take place in the other. It is very probable that the electric tension of each metal is here owing to a difference of action. Let us then admit this principle until experience has proved that it is not correct. Let us take, for example, copper and zinc, and let us represent the electric tensions of the copper and of the liquid, by $+\delta$ and $-\delta$, those of the zinc and of the same liquid by $+\delta'$ and $-\delta'$; the electricity δ of the liquid will be common also to the zinc, as the electricity δ' will be to the copper. It will follow that the electric tensions of the copper and the zinc will be $+\frac{\delta-\delta'}{2}$ and $+\frac{\delta'-\delta}{2}$.

Thus, according as δ shall be greater or less than δ' , the electricity of the copper will be positive or negative, whilst that of the zinc will be the contrary. All leads to the supposition that such is the case.

The following table includes the results of a number of experiments.

Metal

Metal capsule.	Liquid contained in the capsule.	Metal plunged in the Liquid.	Electric State of the cap.
Platinum	Concentrated sulphuric acid	Gold	+
Ditto	Ditto	Silver	+
Ditto	Ditto	Copper	+
Ditto	Ditto	Iron	+
Ditto	Ditto	Lead	+
Ditto	Ditto	Zinc	+
Platinum	Sulphuric acid much diluted	Gold	+
Ditto	Ditto	Silver	+
Ditto	Ditto	Copper	+
Ditto	Ditto	Iron	+
Ditto	Ditto	Lead	+
Ditto	Ditto	Zinc	+
Copper	Concentrated sulphuric acid	Gold	-
Ditto	Ditto	Silver	-
Ditto	Ditto	Platinum	-
Ditto	Ditto	Iron	0
Ditto	Ditto	Lead	0
Ditto	Ditto	Zinc	-
Copper	Diluted sulphuric acid	Gold	-
Ditto	Ditto	Silver	-
Ditto	Ditto	Platinum	-
Ditto	Ditto	Iron	+
Ditto	Ditto	Lead	-
Ditto	Ditto	Zinc	+
Platinum	Solution of potash	Gold	+
Ditto	Ditto	Silver	+
Ditto	Ditto	Copper	+
Ditto	Ditto	Iron	+
Ditto	Ditto	Lead	+
Ditto	Ditto	Zinc	+
Copper	Solution of potash	Gold	-
Ditto	Ditto	Silver	-
Ditto	Ditto	Platinum	-
Ditto	Ditto	Iron	+
Ditto	Ditto	Lead	0
Ditto	Ditto	Zinc	+

By the help of the principle that we have before laid down, we can explain all these results, and even draw consequences from it which will be useful to the electro-chemical theory.

Admitting, as we have already said, that the electric states of the metal box and of the plate of metal be represented by

$$+ \frac{\delta - \delta'}{2} \text{ and } + \frac{\delta' - \delta}{2}$$

($+\delta$ and $-\delta$ being the electric tensions of the box and of the acid liquid which is in it, $+\delta'$ and $-\delta'$ those of the same liquid and of the metallic plate which is plunged in it), it follows, that a vessel of platinum, containing the concentrated sulphuric acid in which shall be plunged a plate of gold, of silver, of copper, or of zinc, will always have for its electric tension $+ \frac{\delta - \delta'}{2}$ a positive quantity;

which requires that δ be greater than δ' ; from whence it is to be concluded, that platinum is more positive in its contact with sulphuric acid than gold, silver, or copper, submitted to the same experiment.

When the vessel of platinum contains sulphuric acid diluted with water, other phenomena take place, which must be taken into account. We have said that platinum, gold, and silver, took the negative electricity in their contact with water diluted with this acid; whilst zinc, lead, iron, and copper, acquired positive electricity. It must be concluded from thence, that for platinum, and zinc the electric state of the first will be $+ \frac{\delta - \delta'}{2} =$ a positive quantity,

and the state of the second $- \frac{\delta - \delta'}{2} =$ a negative quantity;

which always takes place. We also find that the copper is less negative with a solution of potash than the zinc is in its contact with the same liquid.

We have then a process for determining the relations of the electric states of bodies in their contact with liquids. In the contact of the metals it has been found that platinum is always negative with any metal whatever; but it is not yet known, if it be, for example, more negative with gold, than gold is with silver; whilst, in the experiments with which we have just been occupied, similar relations are to be found when one of the bodies is liquid.

Electric Actions produced by the Contact of certain Flames and Metals.

Hitherto we have applied ourselves to the investigation of electric

electric effects only in the contact of the metals with each other, and in that of liquids with the metals and salifiable bases, even when this contact was followed by a chemical action. It has also been shown, that in a circuit formed of two parts of the same metal, if one of them were made red-hot near the points of fusion, an electric current would be established in the entire circuit, when it was closed, of such a kind that the side which was not heated would furnish positive electricity, and the other negative electricity. It has been found also, that the electricity developed in this phenomenon had not sufficient tension to be rendered sensible with a condenser.

We are at present about to occupy ourselves with another class of phenomena. Instead of taking a circuit either wholly metallic, or of metals in contact with any liquids whatever, we shall substitute for these last, inflamed gases, and we shall observe the phenomena which will be then produced. The flames which we shall submit to experiment are those which proceed from the combustion of alcohol, of hydrogen gas, or of a sheet of paper.

Let us place on the capsule of wood or of earthenware which communicates with one of the plates of the condenser, a wire of platinum, or a plate of the same metal of a decimetre in length, and which projects beyond the edge of the plate; let us put the lower plate in communication with the ground; let us plunge one of the extremities of the wire or of the plate in one of the flames of which we have just spoken:—if the metal attains the red temperature, it will take negative electricity; in the contrary case, it will acquire positive electricity. In these two circumstances the flame will always have an electricity opposite to that of the metal. To collect that which the flame takes, a bit of moistened wood is passed upon the capsule, which, not experiencing any combustion, performs the office of a conductor, and transmits to the condenser the electricity which it has taken from the flame.

A copper wire gives a similar result. In general, it appears that all metals possess more or less of the property which we have just observed in platinum and in copper. Thus, a metal plunged in a flame fed by a current of hydrogen gas takes the negative or positive electricity, according as its temperature is more or less elevated, and communicates to the flame the contrary electricity. It now remains to determine the temperatures at which these phenomena are produced in each metal. Now, as the passage from one electric state to another is indicated by the absence of electricity, it follows that

that it sometimes happens that a temperature is communicated to the metal which does not give it any electricity.

When the electricity acquired by the flame is received on one of the plates of the condenser, we can, if we choose, put this in communication with the ground by touching it with a bit of moistened wood. Although the flame, whilst it is continually renewed, carries away with it the electricity that it has acquired in its contact with the metal, the experiment proves that the discharge takes place still more rapidly in operating as we have just indicated. But if, in place of touching the flame with a bit of moistened wood, a plate of the same metal is used as that which is placed on the capsule, it is found that both become established in two different electric states; the plate which is red-hot takes the negative electricity, and that which is less heated, the positive electricity.

Entirely similar effects are obtained when these two plates are made of different metals: we believe, nevertheless, that their intensity is more marked in certain circumstances.

When the jet produced in the flame of a wax-candle by the blow-pipe is used, the same effects are still found.

Do these phænomena result from a friction of the flame on the metals; or are they owing to an electro-motive action? We incline to the latter opinion. It is conceivable that there might be a friction when a metal wire is plunged in the jet of the blow-pipe; but in a tranquil flame, such as that produced by the combustion of alcohol, how could it take place? Besides, how could two plates of the same metal and of unequal thickness, plunged at the same time in a flame, each of them take a different electricity from this cause, only that one has a temperature more elevated than the other; if an electro-motive action be not admitted? It is also very certain that these phænomena do not proceed solely from a difference of temperature in several parts of the same metal, for the extremity of a plate of platinum has been reddened by Mr. Fresnel's powerful lens without any development of electricity resulting from it.

These experiments have not any relation with those of M. Ermann on the conducting properties of the flame of alcohol; they might perhaps have more with the researches of Volta on the combustion of a bit of amadou fixed to the extremity of a stem communicating with one of the plates of the condenser. This illustrious natural philosopher found that when the apparatus was in the open air unvitiated by proximity to inhabited places, the amadou acquired an excess of positive electricity; which, according to him, proceeded from the ambient

air :

air: he thence concluded that the air had always an excess of positive electricity.

In our experiments we could not draw the same conclusion; for we have sometimes one electricity, sometimes another, according to the temperature of the metals. However, new researches will without doubt throw light on these phænomena.

Electric Phenomena which accompany Combustion.

The preceding experiments have naturally led us to investigate what took place during the combustion of certain bodies. A sheet of common paper rolled up, is placed on the wooden capsule; it is set on fire, and then the flame is made to communicate with the common reservoir by the means of a piece of moistened wood, in order that the electricity may flow out more rapidly, and the paper acquires positive electricity. If we operate in a contrary manner, holding the paper in the hand, and making the flame touch a bit of moistened wood placed on the capsule, it is found that the flame takes, on the contrary, the negative electricity. It may then be concluded from these two experiments, that when a piece of paper burns, the paper takes the positive electricity, and the flame the negative electricity. If alcohol be poured into a capsule of copper and set on fire, it will be found by the condenser that the capsule acquires the positive electricity.

Such are the researches which we have made on the electric effects produced by the contact of certain inflamed gases and metals, and by combustion. They are susceptible of many developments; but we have, notwithstanding, thought proper to take the liberty of communicating to the Academy the first results which we have obtained in this class of phænomena.

LXXI. *On a new Fossil Genus, of the Order Enalio Sauri (of Conybeare): and on a new Species of Ichthyosaurus.*
By R. HARLAN, M.D.*

ABOUT sixteen years ago there was deposited by Lewis and Clark, in the cabinet of the American Philosophical Society, a fossil organic remain of some unknown marine animal. During the expedition of these gentlemen up the river Missouri in the year 1804, this specimen was found in a cavern situate a few miles south of the river, near a creek named Soldier's River. The nature of the soil at this locality they do not mention, but there can be little doubt of its being secondary; as a few miles down the river, at Council Bluff, there

* From the *Journal of the Acad. of Nat. Sciences of Philadelphia*, vol. iii. p. 331, 338.

are hills of considerable size, composed almost entirely of fossil marine shells and other organic reliquia in a fossil state.

My attention was first directed to this specimen by Mr. T. Say, who with his accustomed liberality offered every assistance in deciphering the same. At first view I recognised it as a portion of the dental bone of an animal allied to the Saurian reptiles: a closer inspection proved its approximation to the new fossil genus *Ichthyosaurus*; an animal, as the name imports, uniting in its structure both the fish and the lizard; having the head of a lacertian animal joined to the vertebræ of a fish, and extremities entirely *sui generis*. For a full description of this highly interesting animal, together with another new fossil genus, the *Plesiosaurus*, naturalists are particularly indebted to an able and elaborate essay, by the Rev. W. D. Conybeare and Mr. De la Beche (in the *Trans. of the Geolog. Soc.* 2d series, vol. i. part 1; and in vol. v.) in which they have described four distinct species of the *Ichthyosaurus*.

By the most critical examination of the present specimen, it is found to possess characters which incontestably render it at least specifically, if not generically, different from either.

Our specimen, Plate III. is rendered doubly interesting by its locality, being the first of the genus ever discovered on this continent. While we have to lament that so small a remnant of this animal has been snatched from oblivion, it still serves to display the utility as well as beauty of the doctrine of the laws of co-existence in the parts of animals, when employed with that caution which renders it a legitimate instrument of induction. A perfect knowledge of these laws enabled Cuvier to establish important species, on data far less certain than that now under consideration: not to mention many others, the *Anoplotherium medium* was originally founded on a portion of the lower jaw.

From the data afforded by the account of the *Ichthyosaurus* above mentioned, the following would appear to be its *generic* characters:—Teeth fixed in an open sulcus, instead of separate alveoli; consisting of two series only, one growing within the other; anterior nares opening near the root of the snout, immediately before the lachrymal bones. Bones of the head and face, in number and structure, nearly resembling the Crocodile; bodies of the vertebræ concave both at their occipital and caudal surfaces; legs four in number, terminating in a paddle, composed of a numerous series of polygonal bones, and attached immediately to the distal extremities of the humerus and femur; anterior extremities much larger than the posterior. Amphibious? Oviparous.

In order to demonstrate wherein the present differs from those species of the Ichthyosaurus already described, it will be necessary briefly to state their specific characters, which, as in most other instances, have been drawn principally from the teeth.

1. *I. communis*. Upper part of the tooth conical, not very acute, slightly aduncate, and thickly covered with prominent, longitudinal striæ.

2. *I. platyodon*. Upper part of the tooth smooth and flattened, so as to present sharpened edges.

3. *I. tenuirostris*. Teeth more slender than the preceding species, but is best marked by the extreme length and thinness of the snout.

4. *I. intermedius*. The upper part of the teeth much more acutely conical than in species first; and the striæ less prominent, yet less slender than in species third. These species vary in size: those of the first differ from five to fifteen feet, but the most gigantic belong to species second.

The animal to which our specimen belonged may have been about six or eight feet in length. The remnant from which these observations were drawn is a portion of the dental bone of the right side; its greatest length four inches, greatest breadth two inches; alveolar surface three inches and a half long, three-tenths in thickness.

“The most important difference between the lower jaw of the Crocodile and Ichthyosaurus is, that the bones are not connected by *true* suture in the latter, but by squamous suture as in fishes*.”

In which circumstance our specimen perfectly corresponds, as is demonstrated by fig. 4. (a.) The inferior and posterior edges being thinned and imbricated for articulation with the angular bone.

There are eighteen teeth in different states of preservation; the longest are seven-tenths of an inch, two-tenths only projecting above the bone; the projecting part enamelled, smooth and shining, lanciform; the edges very sharp: but this will be better understood by referring to fig. 1st. The bodies of the teeth are all hollow, and are firmly fixed in a longitudinal groove, there being no distinct, separate alveolæ. The bodies of the teeth are in *close contact throughout*, in which respect it differs from the other species of the Ichthyosaurus, the Plesiosaurus, and the Saurian reptilia: it differs, further, from all these animals in the following respect;—the body of the bone is not perforated by a canal for the inferior maxillary nerve; in place of which is observed a groove running the whole

* Conybeare.

length of the dental bone, immediately beneath the alveolar portion, on the mesial aspect of the bone; the bottom of this groove is perforated with foramina for the distribution of the nerves and blood-vessels, equal in number to the teeth (*i. e.* 18).

The process of dentition appears also to possess some peculiarities; being two series, one directly above the other, both hollow (the cavities in some instances filled up with crystallized carbonate of lime); the mode of shedding the teeth is similar, but the manner in which the inferior enters the superior, differs from the animals above referred to; the inferior entering the cavity of the superior directly at the centre, and not at the side of the body.

The inferior series are completed before they enter the upper. I could observe no appearance of a third series, except indeed the cavity in the second. The teeth of this species are neither conical nor striated, which is not the case in the other species, excepting the *tenuirostris*, in which the superior portion is smooth, curved, and conical; the lower half striated.

The extreme sharpness of the cutting edge of the teeth, and the juxtaposition of their bodies, precludes the possibility of supposing the teeth of the upper jaw to have passed between those of the lower jaw, when the mouth was closed, as is the case in all the animals we have referred to in this paper.

The row of teeth on the inferior appear to have passed within those of the superior jaw: this supposition is further strengthened by the worn appearance of the sides of the teeth.

This arrangement of the teeth, which would require a peculiar configuration of the jaw, together with the peculiar distribution of the inferior maxillary nerve mentioned above, appears to me to entitle this animal to rank as a new genus. In many respects it approaches very nearly the *Ichthyosaurus*, but is separated from this genus of animals by the peculiarities expressed above. We propose to distinguish this animal by the following name and characters.

SAUROCEPHALUS lanciformis.

Generic characters. Bodies of the teeth approximated; those of the superior and inferior jaws closing like incisors. Inferior maxillary nerve passing along a groove on the mesial aspect of the dental bone.

Specific characters. Projecting portions of the teeth smooth and lanciform.

PLATE III.

- | | |
|---|---|
| <p>Fig. 1. Tooth detached.
 2. Teeth in their sockets magnified.
 <i>a.</i> The young tooth.</p> | <p>Fig. 3. The dental bone, mesial aspect.
 4. dermal aspect.
 <i>a. a.</i> articulating surface.
 5. Dental bone seen from above.</p> |
|---|---|

On a new extinct Fossil Species of the Genus ICHTHYOSAURUS.

SOON after writing my last paper on the *Saurocephalus*, my attention was directed to a small fragment of petrified bone deposited in the collection of British fossils in the Philadelphia Museum.

This specimen was originally from Bath or Bristol, and is easily recognised, at first view, for a portion of the dental bone of some Saurian reptile; though from the small size and crushed state of the specimen, and from its being in some degree imbedded in a matrix of calp, it was at first difficult to ascertain to what genus it belonged.

Nevertheless, an attentive examination of this portion of dental bone, a little more than an inch in length, and containing six teeth, enabled me eventually to ascertain the following facts.

The remnant is six-tenths of an inch high, and five-tenths broad at the alveolar aspect. The largest teeth (for they vary in size) are $\cdot 65$ of an inch long, projecting three-tenths above the bone; the projecting portion being marked with closely arranged, longitudinal striæ; a few widely separated longitudinal lines mark the buried portion of the tooth, and the whole tooth is conoidal from the base to the apex.

In the mode of dentition this animal resembles the crocodile; but it differs in having the teeth set in a continued groove, instead of separate alveoli. It varies from the *Plesiosaurus* in the same respect, and in the teeth, though conical, being not so long proportionably, nor in the same degree aduncate as in that animal. It should be remembered that the teeth of animals of this order vary in the latter respect even in the same jaw, as is particularly the case in the *I. intermedius*.

Our specimen totally differs from the *Saurocephalus*, in the relative size, form and proportion of the teeth and dental bone, and in the bodies of the teeth not being approximated or contiguous.

It resembles the *Ichthyosaurus* in the relative proportions of the teeth, in having them set in a groove, and in its mode of dentition. It approaches most nearly to the *I. communis* in the general appearance of the teeth, but differs from that species in their relative size and form; these bodies being more aduncate in the latter.

It differed from all the four species in the greater relative thickness of the dental bone. In fine, it no more resembles these species, than they respectively resemble each other. From these data I am led to believe the present specimen to
have

have belonged to a species not before described, and propose to denominate it *ICHTHYOSAURUS coniformis*.

PLATE III.

Fig. 6. (a.) Tooth of the natural size *in situ*.
 7. do. magnified.
 8. do. transverse section do.

[For the following note we are indebted to the Rev. Mr. Conybearc.—EDIT.]

“ In reference to this paper, Mr. Conybearc observes, that, judging from the data afforded by the present figures, the tooth ascribed to *Ichthyosaurus coniformis* does not appear to him to differ from those of *I. communis* sufficiently to warrant the establishment of a new species:—the only differences described are a less degree of aduncation in the tooth, and a greater thickness in the dental bone; but as it should appear that Dr. Harlan drew his conclusions from comparison not with other actual specimens, but only with the engravings in the *Geological Transactions*, some hesitation must be felt in admitting them, especially as the aduncation of the teeth in *I. communis* is itself very slight; and the character of their striæ is but faintly marked in many impressions of the lithographic plate in the *Geological Transactions*.

“ Mr. Conybearc wishes, however, merely to postpone the adoption of this new species of *Ichthyosaurus* until these points can be determined by the comparison of actual specimens, which he hopes to facilitate by transmitting some teeth, &c. of the species previously ascertained, to America.

“ The *Saurocephalus* does not yet appear to have been found in England, and forms an important addition to the very interesting class of fossil *Sauri*.”

LXXII. *Lava found on the Sands near Boulogne*. By
 ROBERT BAKEWELL, Esq.

To the Editors of the Philosophical Magazine and Journal.
 Gentlemen,

WHEN I was at Boulogne in September last, I was informed that masses of lava, of different sizes, were frequently found on the sands west of the harbour. M. Dutertre in the lower town had several specimens, from which he obligingly broke one to give me a part.

The lava is of a darkish gray colour, porous, but extremely hard, and filled with grains of olivine; it bears a close resemblance to the lava from the Puy de Nugerre in Auvergne, described in the second volume of my *Travels in the Tarentaise*, &c., except that the latter contains no olivine, at least in those parts where I examined it. An inquiry suggests itself of some importance in Geology—Are these masses of lava which are left on the sands after high tides, merely fragments that have been thrown out as ballast somewhere on the coast? Or are they derived from volcanic rocks hitherto unnoticed in Brittany or Normandy, which, like those of Auvergne, may have

have been erupted from beneath the granite, and intermixed with it on the surface? If the latter, we may well conceive that fragments brought down by the rivers might be washed by the tides and currents as far west as Boulogne.

Yours truly,

Torrington Square, Dec. 10, 1824.

ROBT. BAKEWELL.

P.S.—M. Dutertre had other specimens of a different character, of which the volcanic origin was more problematical: one semivitreous, containing globules of metallic tin. He had also a very large deep yellow topaz found on the shore.

LXXIII. *Introduction to the Seventh Section of BESSEL'S Astronomical Observations.*

[Concluded from p. 349.]

MESSRS. Rosenberger and Scherck have found the probable error of observation from very numerous comparisons, = $1''\cdot541$, which determination may be assumed to belong to the zenith distance 45° ; applying to this determination the increase of the probable error depending on the zenith distance, which has been given in the 7th article, the probable errors of an observation with Cary's circle will be for the zenith distances

0° 45° 60° 65° 70° 75° 80° 85°
 = $\pm 1''\cdot517$; $1''\cdot541$; $1''\cdot555$; $1''\cdot562$; $1''\cdot585$; $1''\cdot655$; $1''\cdot775$; $2''\cdot286$.

A former determination gave the probable error of a mean of four observations of α *Ursæ Minoris* in zenith distance $36^\circ = 0''\cdot6845$, likewise independent of the errors of division; according to the present determination, it would be = $0''\cdot77$: the difference may be accounted for by the uncertainty of the error of collimation involved in the second, and perhaps likewise by the greater care taken in observing the pole-star. Besides these contingent errors of observation, every zenith distance has the error arising from the peculiar error of the individual divisions on which they depend: this later one might have been entirely avoided, if these divisions had been determined directly by my method, as I first intended, but was prevented from doing by other business and by the near prospect of obtaining Reichenbach's circle. The probable quantity of the remaining error of division is found by the zenith distances of the above-named 38 stars, measured in both positions of the instrument, to be = $1''\cdot004$; so that the probable error of the mean of an observation made in the same

position of the instrument, is = $\sqrt{\{(1''\cdot004)^2 + \frac{t^2}{a}\}}$; By this formula, the probable errors of the single determinations and the most probable declinations have been computed as follow:

α Aurigæ

	Probable Errors.		Most probable Declination for 1815.	Probable Errors.
	East.	West.		
	"	"	° ' "	"
α Aurigæ	1·05	1·06	45 47 44·72	0·57
	1·24	1·26		
α Cygni	1·11	1·09	44 37 26·21	0·58
	1·22	1·25		
α Lyræ	1·07	1·06	38 37 4·01	0·75
α Geminorum	1·06	1·05	32 16 54·66	0·75
β —	1·06	1·05	28 27 44·14	0·75
β Tauri	1·08	1·08	28 26 20·09	0·76
α Andromedæ	1·07	1·07	28 4 3·28	0·76
α Coronæ	1·07	1·07	27 20 34·61	0·76
α Arietis	1·16	1·10	22 34 56·11	0·80
α Bootis	1·05	1·07	20 9 0·75	0·75
α Tauri	1·07	1·11	16 7 37·29	0·77
β Leonis	1·14	1·10	15 36 20·92	0·79
α Herculis	1·09	1·07	14 36 32·52	0·76
α Pegasi	1·10	1·08	14 12 41·94	0·77
γ —	1·05	1·06	14 9 13·02	0·75
α Leonis	1·06	1·07	12 51 59·71	0·75
α Ophiuchi	1·08	1·08	12 42 10·37	0·77
γ Aquilæ	1·07	1·07	10 10 12·28	0·76
α —	1·05	1·04	8 23 14·89	0·74
α Orionis	1·07	1·09	7 21 45·21	0·76
α Serpentis	1·07	1·10	7 0 53·37	0·77
β Aquilæ	1·06	1·05	5 57 9·29	0·75
α Canis Min.	1·05	1·05	5 41 23·13	0·75
α Ceti	1·34	1·19	3 21 23·46	0·89
β Virginis	1·09	1·09	2 48 23·20	0·77
α Aquarii	1·35	1·19	— 1 12 48·98	0·89
α Hydræ	1·19	1·15	— 7 51 44·39	0·83
β Orionis	1·15	1·13	— 8 25 27·36	0·80
α Virginis	1·03	1·04	—10 11 33·88	0·73
1 α Capricorni	1·12	1·09	—13 4 20·91	0·78
2 α —	1·17	1·35	—13 6 40·64	0·89
1 α Libræ	1·17	1·18	—15 13 14·64	0·84
2 α —	1·13	1·19	—15 15 58·17	0·82
α Canis Maj.	1·04	1·04	—16 28 14·68	0·73
α Scorpii	1·14	1·28	—26 0 39·17	0·85
α Pisc. austr.	1·38	1·22	—30 36 2·81	0·91

The greater part of these observations have already been computed by Professor Littrow: his results in general agree with the present ones, although the change of form of the elements

ments of calculation, the further continuation of the observations, and the mode of taking the means, have produced some differences. The comparison of that computation with the catalogues of Pond, Oriani, and Piazz, showed, however, that my observations give the declinations further south; this caused new examinations of the divisions, the results of which have been used. But these examinations created as little doubt on the general correctness of the results, as the former ones; nor can a flexure of the telescope of this instrument be apprehended, for both ends and the middle of it are fastened between the two parallel circles, one of which has the divisions on it. I trusted, therefore, that in process of time a confirmation of even the greatly deviating results would take place; and I endeavoured, from the commencement of the observations with the new instrument, to take such measures as would render its decision as complete as possible. I have here presented to the view of the astronomers these measures, and now offer, without any further explanation, the results of my observations of the 36 stars, made with Reichenbach's circle, till the end of this year (1821).

	Declinations for 1820.							
	East.	$\overset{\circ}{\underset{N}{Z}}$	Prob. Errors.	West.	$\overset{\circ}{\underset{Z}{N}}$	Prob. Errors.	Most probable Declinations.	Prob. Errors.
α Aurigæ	45° 48' 9" 20	24	0.32	8' 63"	28	0.31	45 48 9.12	0.18
α Cygni	44 38 28.54	23	0.32	28.04	22	0.32	44 38 28.47	0.18
α Lyræ	38 37 17.44	10	0.36	18.03	20	0.32	38 37 17.77	0.24
α Geminor.	32 16 21.26	19	0.33	20.86	34	0.31	32 16 21.05	0.23
β —	28 27 6.07	28	0.31	5.05	44	0.30	28 27 5.54	0.22
β Tauri	28 26 40.64	33	0.31	40.12	19	0.33	28 26 40.40	0.23
α Andromed.	28 5 46.70	30	0.31	46.48	26	0.31	28 5 46.59	0.22
α Coronæ	27 19 34.10	30	0.31	34.76	39	0.30	27 19 34.44	0.22
α Arietis	22 36 22.19	16	0.34	22.45	20	0.32	22 36 22.32	0.23
α Bootis	20 7 25.32	42	0.30	25.55	40	0.30	20 7 25.43	0.21
α Tauri	16 8 17.02	30	0.31	17.30	30	0.31	16 8 17.16	0.22
β Leonis	15 34 40.23	13	0.35	39.87	17	0.33	15 34 40.04	0.24
α Herculis	14 36 10.44	17	0.33	10.46	16	0.34	14 36 10.45	0.24
α Pegasi	14 14 19.13	19	0.33	18.96	15	0.34	14 14 19.05	0.24
γ —	14 10 56.18	22	0.32	56.26	17	0.33	14 10 56.22	0.23
α Leonis	12 50 43.59	22	0.32	43.58	28	0.31	12 50 33.58	0.22
α Ophiuchi	12 41 55.55	11	0.36	55.75	21	0.32	12 41 55.66	0.24
γ Aquilæ	10 10 53.82	24	0.32	54.12	23	0.32	10 10 53.97	0.23
α —	8 24 0.32	47	0.30	1.06	50	0.30	8 24 0.69	0.21
α Orionis	7 21 50.48	28	0.31	50.90	26	0.32	7 21 50.69	0.22
α Serpentis	6 59 54.70	21	0.33	54.96	31	0.31	6 59 54.84	0.23
β Aquilæ	5 57 50.75	27	0.32	50.93	26	0.32	5 57 50.84	0.23
α Canis Min.	5 40 40.41	33	0.30	40.23	48	0.30	5 40 40.32	0.21
α Ceti	3 22 37.67	15	0.34	37.66	14	0.35	3 22 37.67	0.24
β Virginis	2 46 42.79	3	0.53	42.82	13	0.35	2 46 42.81	0.29
α Aquarii	— 1 11 25.86	19	0.33	25.14	29	0.31	— 1 11 25.48	0.23

	Declinations for 1820.											
	East.		Prob. Errors.	West.		Prob. Errors.	Most probable Declinations.	Prob. Errors				
	°	'		°	'							
α Hydræ	- 7	53	1'63	19	0'33	1'73	28	0'32	- 7	53	1'68	0'23
β Orionis	- 8	25	4'13	17	0'34	4'30	19	0'33	- 8	25	4'22	0'24
α Virginis	-10	13	7'71	31	0'31	7'67	34	0'31	-10	13	7'69	0'22
1 α Capric.	-13	3	24'96	3	0'56	26'00	6	0'45	-13	3	25'59	0'35
2 α —	-13	5	42'77	7	0'43	44'69	3	0'56	-13	5	43'49	0'35
1 α Libræ	-15	14	33'25	12	0'37	33'29	13	0'37	-15	14	33'27	0'25
2 α —	-15	17	15'16	13	0'37	14'94	13	0'37	-15	17	15'05	0'25
α Canis Maj.	-16	28	37'28	25	0'33	37'03	26	0'33	-16	28	37'15	0'23
α Scorpii	-26	1	22'81	21	0'38	23'19	24	0'37	-26	1	23'00	0'26
α Pisc. austr.	-30	34	28'28	16	0'55	29'02	20	0'51	-30	34	28'68	0'37

The relation of my two catalogues to one another, and to those of other astronomers, may be seen from the following comparison, in which the proper motion of stars has been so assumed as it results from the places for 1755.

	Annual Variation.		Differences from				Pond.	
	1820.	Secular Variat ⁿ .	Bessel	Piazz	Oriani	Brinkley	Stand.	Nautical
			1815.	1800.	1811.	1813.	Catal.	Alman. 1824.
α Aurigæ	+ 4'478	-0'627	-1'93	-0'81	" ...	+1'67	+1'88	-0'12
α Cygni	+12'563	+0'227	+0'53	+2'14	+1'02	+1'08	+2'42	+1'53
α Lyræ	+ 2'962	+0'291	+1'01	+1'69	+1'36	+2'05	+2'39	+2'23
α Geminor.	- 7'190	-0'527	-2'27	+1'20	" ...	+1'21	+2'05	-0'05
β —	- 8'087	-0'491	-1'77	+0'50	" ...	+1'92	+1'57	-0'54
β Tauri	+ 3'712	-0'540	-1'68	+0'42	+1'69	+1'44	+2'02	+0'60
α Andromed.	+19'906	+0'004	-3'78	+0'52	" ...	+2'43	+3'15	+0'41
α Coronæ	-12'483	+0'296	-2'28	+3'31	+2'15	+2'60	+2'71	+2'56
α Arietis	+17'350	-0'247	+0'57	+1'67	" ...	+2'43	+2'69	+0'68
α Bootis	-19'009	+0'216	+0'25	+2'26	+1'35	+2'07	+2'45	+1'57
α Tauri	+ 7'855	-0'461	-0'54	+2'86	+2'79	+1'96	+2'54	-0'16
β Leonis	-20'083	-0'036	+0'47	+3'07	" ...	+2'95	+2'09	+1'96
α Herculis	- 4'614	+0'387	-1'05	+4'20	+2'35	+2'54	3'18	+2'55
α Pegasi	+19'258	+0'116	-0'83	+2'98	+2'51	+2'93	+4'13	+1'95
γ —	+20'028	-0'017	-3'06	+0'97	" ...	+2'80	+2'98	+3'78
α Leonis	-17'310	-0'233	-0'39	+2'69	+2'60	+2'25	+2'61	+2'42
α Ophiuchi	- 3'125	+0'400	-0'97	+4'04	+2'47	+1'88	+3'27	+2'34
γ Aquilæ	+ 8'286	+0'376	-0'31	+2'40	" ...	+2'60	+3'34	+4'03
α —	+ 9'002	+0'384	-0'84	+3'78	+2'51	+2'38	+3'43	+2'31
α Orionis	+ 1'267	-0'473	+0'91	+0'60	+2'76	+2'36	+3'60	+1'31
α Serpentis	-11'791	+0'349	-0'47	+2'34	+2'12	+3'73	+3'24	+2'16
β Aquilæ	+ 8'488	+0'369	+0'84	+3'38	" ...	+3'27	+4'39	+5'16
α Canis Min.	- 8'737	-0'422	-0'82	+4'28	+3'04	+3'29	+4'22	+0'68
α Ceti	+14'491	-0'319	-1'72	+1'59	" ...	+1'81	+3'15	+4'33
β Virginis	-20'289	-0'033	-1'05	+1'48	" ...	" ..	" ..	+2'19
α Aquarii	+17'195	+0'227	+2'45	+2'93	" ...	+4'04	+4'19	+4'48
α Hydræ	-15'273	-0'273	+0'96	+2'27	" ...	+3'85	+3'54	+4'68
β Orionis	+ 4'661	-0'411	+0'22	+1'86	+2'78	+2'68	+3'15	+4'22
α Virginis	-19'027	+0'153	-1'34	+2'84	+3'00	+3'13	+3'16	+4'69
1 α Capricor.	+10'581	+0'411	-2'47	+4'89	" ...	+3'47	+4'16	+4'59

2 α Capricor.

	Annual Variation.		Differences from					
	1820.	Secular Variat ⁿ .	Bessel 1815.	Piazzi 1800.	Oriani 1811.	Brinkley 1813.	Pond.	
							Stand. Catal.	Nautical Alman. 1824.
2 α Capricor.	+10.609	+0.411	-4.16	+4.65	+3.68	+5.62	+5.35	+6.49
1 α Libræ	-15.405	+0.311	+1.57	+2.54	...	+...	+6.66	+7.27
2 α —	-15.374	+0.313	-0.03	+2.94	...	+4.76	+4.65	+5.05
α Canis Maj.	-4.483	-0.380	+0.10	+2.05	+5.36	+1.59	+5.16	+1.15
α Scorpii	-8.649	+0.484	+0.52	+3.05	+2.65	+5.57	+5.74	+4.00
α Pisc. austr.	+18.836	+0.149	+0.03	+3.80	+3.71	+...	+...	+2.68
Mean of the differences from α Aurigæ to β Leonis			-0.95	+1.57	+1.73	+1.98	+2.33	+0.89
α Herculis to α Ceti			-0.73	+2.77	+2.54	+2.65	+3.46	+2.75
β Virginis to α Pisc. austr.			-0.27	+3.02	+3.53	+3.86	+4.58	+4.29

Königsberg Refractions.

z.D	α .	A.	λ .
30	1.76138		
35	1.76129		
40	1.76121		
45	1.76103		1.0018
50	1.76081		1.0023
55	1.76050		1.0032
60	1.76000		1.0046
61	1.75988		1.0049
62	1.75973		1.0054
63	1.75957		1.0058
64	1.75939		1.0063
65	1.75919		1.0068
66	1.75896		1.0075
67	1.75871		1.0083
68	1.75842		1.0092
69	1.75808		1.0101
70	1.75771		1.0111
71	1.75726		1.0124
72	1.75676		1.0139
73	1.75615		1.0156
74	1.75543		1.0175
75	1.75457		1.0197
76	1.75355		1.0220
77	1.75229	1.0026	1.0252
78	1.75072	1.0030	1.0299
79	1.74876	1.0035	1.0357
80	1.74623	1.0041	1.0420

Barometrical Correction.	β .
Paris line.	
325	-1023
326	-889
327	-756
328	-624
329	-491
330	-360
331	-228
332	-97
333	+33
334	+164
335	+293
336	+423
337	+552
338	+681
339	+809
340	+937
341	+1064
342	+1192
343	+1318
344	+1445
345	+1571

The logarithm of the refraction expressed in seconds, with five decimal figures, is = $\log. \text{tang } z + \alpha + \Lambda. \beta - 7A. \tau' + \lambda$ where τ' signifies the centesimal degree of the thermometer attached to the barometer.

The readings of the Königsberg barometer are to be increased by +0.503.

The refractions given with the observations to the end of the year 1821, require to be multiplied by the following factor.

τ .	
-20°	1-0.00625
-10	1-0.00445
0	1-0.00280
+10	1-0.00110
20	1+0.00033
30	1+0.00170
40	1+0.00325
50	1+0.00489
60	1+0.00635
70	1+0.00767
80	1+0.00879
90	1+0.01000

*Thermometrical Correction for the true FAHRENHEIT
Thermometer.*

<i>f.</i>	γ .	<i>f.</i>	γ .	<i>f.</i>	γ .
-25°	+6787	+15°	+2975	+55°	-529
-24	+6688	16	+2884	56	-613
-23	+6588	17	+2793	57	-697
-22	+6489	18	+2702	58	-781
-21	+6391	19	+2612	59	-865
-20	+6292	20	+2521	60	-948
-19	+6193	21	+2431	61	-1031
-18	+6095	22	+2341	62	-1114
-17	+5998	23	+2251	63	-1197
-16	+5900	24	+2162	64	-1280
-15	+5802	25	+2072	65	-1363
-14	+5705	26	+1983	66	-1445
-13	+5608	27	+1894	67	-1528
-12	+5511	28	+1805	68	-1610
-11	+5415	29	+1716	69	-1692
-10	+5318	30	+1628	70	-1774
-9	+5222	31	+1539	71	-1855
-8	+5126	32	+1451	72	-1937
-7	+5030	33	+1363	73	-2018
-6	+4935	34	+1275	74	-2100
-5	+4839	35	+1188	75	-2181
-4	+4744	36	+1100	76	-2262
-3	+4649	37	+1013	77	-2343
-2	+4555	38	+926	78	-2423
-1	+4460	39	+839	79	-2504
0	+4366	40	+752	80	-2584
+1	+4272	41	+665	81	-2664
2	+4178	42	+579	82	-2744
3	+4084	43	+493	83	-2824
4	+3990	44	+407	84	-2904
5	+3897	45	+321	85	-2984
6	+3804	46	+235	86	-3063
7	+3711	47	+149	87	-3142
8	+3618	48	+64	88	-3222
9	+3526	49	-21	89	-3301
10	+3434	50	-106	90	-3379
11	+3342	51	-191	91	-3458
12	+3250	52	-276	92	-3537
13	+3158	53	-361	93	-3615
14	+3066	54	-445	94	-3694
15	+2975	55	-529	95	-3772

Correction of the Observations with the Meridian Circle for Flexure and Division.

0	+ 0.24	+ 0.98	+ 1.05	+ 1.54	- 0.34	+ 0.98	0	- 1.15	+ 1.54
2	0.24	0.95	1.00	1.57	0.42	0.95	180	1.18	1.57
4	0.24	0.88	0.95	1.64	0.50	0.88	182	1.21	1.64
6	0.25	0.78	0.92	1.74	0.55	0.78	184	1.22	1.74
8	0.28	0.66	0.89	1.86	0.60	0.66	186	1.21	1.86
10	0.32	0.54	0.88	1.98	0.64	0.54	188	1.20	1.98
12	0.34	0.42	0.85	2.10	0.68	0.42	190	1.19	2.10
14	0.40	0.32	0.85	2.20	0.70	0.32	192	1.15	2.20
16	0.49	0.23	0.89	2.29	0.67	0.23	194	1.07	2.29
18	0.61	0.21	0.95	2.31	0.63	0.21	196	0.97	2.31
20	0.74	0.20	1.03	2.32	0.56	0.20	198	0.85	2.32
22	0.86	0.28	1.10	2.24	0.50	0.28	200	0.74	2.24
24	0.96	0.38	1.14	2.14	0.46	0.38	202	0.64	2.14
26	1.03	0.53	1.16	1.99	0.45	0.53	204	0.58	1.99
28	1.10	0.70	1.17	1.82	0.44	0.70	206	0.21	1.82
30	1.13	0.83	1.14	1.69	0.47	0.83	208	0.48	1.69
32	1.16	0.94	1.11	1.58	0.50	0.94	210	0.45	1.58
34	1.18	1.03	1.07	1.49	0.54	1.03	212	0.43	1.49
36	1.19	1.09	1.03	1.43	0.57	1.09	214	0.41	1.43
38	1.23	1.13	1.01	1.39	0.59	1.13	216	0.37	1.39
40	1.25	1.12	0.98	1.40	0.61	1.12	218	0.34	1.40
42	+ 1.25	+ 1.06	+ 0.93	+ 1.46	- 0.65	+ 1.06	220	- 0.33	+ 1.46
							222		
							270		
							272		
							274		
							276		
							278		
							280		
							282		
							284		
							286		
							288		
							290		
							292		
							294		
							296		
							298		
							300		
							302		
							304		
							306		
							308		
							310		
							312		

<i>u.</i>	<i>a.</i>	<i>b.</i>	<i>u.</i>	<i>a.</i>	<i>b.</i>	<i>u.</i>	<i>a.</i>	<i>b.</i>	<i>u.</i>	<i>a.</i>	<i>b.</i>
44	+1.29	+0.96	134	+0.90	+1.56	224	-0.67	+0.96	314	-0.28	+1.56
46	1.33	0.84	136	0.88	1.68	226	0.67	0.84	316	-0.23	+1.68
48	1.33	0.75	138	0.84	1.77	228	0.69	0.75	318	-0.20	+1.77
50	1.30	0.66	140	0.76	1.86	230	0.76	0.66	320	-0.22	+1.86
52	1.28	0.63	142	0.68	1.89	232	0.82	0.63	322	-0.22	+1.89
54	1.26	0.60	144	0.60	1.92	234	0.88	0.60	324	-0.22	+1.92
56	1.18	0.74	146	0.48	1.78	236	0.98	0.74	326	-0.28	+1.78
58	1.09	0.89	148	0.34	1.63	238	1.09	0.89	328	-0.34	+1.63
60	1.09	1.04	150	0.29	1.48	240	1.12	1.04	330	-0.31	1.48
62	1.08	1.40	152	0.23	1.32	242	1.14	1.20	332	-0.29	+1.32
64	1.12	1.33	154	0.22	1.19	244	1.12	1.33	334	-0.22	+1.19
66	1.16	1.45	156	0.21	1.07	246	1.10	1.45	336	-0.15	+1.07
68	1.20	1.54	158	0.21	0.98	248	1.06	1.54	338	-0.07	+0.98
70	1.23	1.60	160	0.19	0.92	250	1.05	1.60	340	-0.01	+0.92
72	1.25	1.65	162	0.17	0.87	252	1.03	1.65	342	+0.05	+0.87
74	1.27	1.71	164	0.16	0.81	254	1.01	1.71	344	+0.10	+0.81
76	1.29	1.70	166	0.14	0.82	256	0.99	1.70	346	+0.16	+0.82
78	1.29	1.69	168	0.10	0.83	258	0.99	1.69	348	+0.20	+0.83
80	1.30	1.68	170	0.07	0.84	260	0.98	1.68	350	+0.25	+0.84
82	1.27	1.64	172	0.01	0.88	262	0.99	1.64	352	+0.27	+0.88
84	1.24	1.60	174	-0.06	0.92	264	1.02	1.60	354	+0.28	+0.92
86	1.18	1.56	176	-0.15	0.96	266	1.06	1.56	356	+0.27	+0.96
88	1.10	1.52	178	-0.26	1.00	268	1.12	1.52	358	+0.24	+1.00
90	+1.05	+1.54	180	-0.34	+0.98	270	-1.15	+1.54	360	+0.24	+0.98

LXXIV. Decas tertia novarum Plantarum Succulentarum; *Autore* A. H. HAWORTH, *Soc. Linn. Lond.—Soc. Horticult. Lond.—non Soc. Cæsar. Nat. Curios. Moscoviensis Socio, &c. &c.*

To the Editors of the Philosophical Magazine and Journal.

Gentlemen,

A THIRD Decade of New Succulent Plants, I have here—under the satisfaction of forwarding to you, which, it is hoped, will find an early admission into your valuable Magazine. This Decade is composed of minute descriptions of unrecorded species of the genus *Mesembryanthemum*; forming, indeed, a splendid addition to that extensive and interesting group—all pretty recently discovered in the Cape countries of Southern Africa, by the enterprising zeal of Mr. Bowie; and all sent safe to the Royal Gardens of Kew, through his skilful management in the packing and transmittal of succulent seeds and roots.

In those well-conducted gardens, these fine plants seem really to be quite at home; and have (except three) already produced their fructifications; and many of them, as Mr. Bowie himself assured me while we were examining them, have almost exactly the face or appearance which they usually assume in their own remote and native land.

The descriptions, therefore, which here follow, ought at least to be tolerably good; although the writer, ever diffidently fearful of his own powers, barely hopes that they may be sufficient to enter upon the records of the science which he loves, and only there remain, till others shall appear from abler hands. I remain, gentlemen,

Your most obedient servant,

Queen's Elm, Chelsea, Nov. 19, 1824.

A. H. HAWORTH.

Classis et Ordo. ICOSANDRIA PENTAGYNIA.

Genus, MESEMBRYANTHEMUM.

Sectio, CARINANTIA.

Acaulia: foliis densè decussatis erecto-incurvis acutè triquetris carinatis acinaciformibusve, subtuberculatim magnipunctatis: *scapis* ramosis conspicuis: corollis luteis.

Species.

scapiger. M. (The great scaped), foliis carinato-triquetris viridibus margine punctisque asperiusculis: scapo valido subpaniculato ancipiti.

Floret Aug. Sept. G. H. 4.

Descriptio.

Descriptio. *M. bellidiflori* habitu, at longè majus; foliis integerrimis, basin versus depresso-senicylindricis, pone medium acutè carinatis. *Scapus* erectus semipedalis plusve, bracteis magnis acutè carinatis gladiiformibus, mucrone membranaceo albo incurvo finientibus, basi decurrentibus: *pedunculi* subunciales atque ancipites clavellati rugosiusculi supernè bracteolati.

Calyx facilè mediocris (ratione plantæ magnitudinis), foliolis quinque longis subæqualibus acuminatis, omnibus sine membranâ ordinariâ. *Flores* flavi (an pomeridiani?) petalis ordinariis externè saturatoribus at supernè aliquantillùm subindè purpurascentibus, calycum longitudine. *Germen* mediocre altissimè quinqueporcatum, porcis obtusis. *Styli* quinque graciles subulati, sub lente marginibus ramentaceo-ciliatis.

Obs. Species conspicua, distinctissima, pone *M. carinantem* locandum. Florem unum Augusto mense solum dissecavi.

Sectio, VAGINATA.

Species.

acutangulum. *M.* (sharp-angled), foliis subrectangulatim triquetris acuminatis incurvo-recurvulis viridibus, marginibus asperiusculis.

Floret

G. H. h.

Obs. Suffrutex erecto-dumosus, longè humilior quàm *M. curtum* α Nob. cui simillimum, sed foliorum minorum marginibus acutioribus, asperioribus.

Obs. *M. curtum* δ Nob. est *M. hamatum* Willd. et fortè vera species. *M. curtum* γ *politum* Nob. est etiam fortè distinctum; magis strictum, foliis minoribus gracilioribus. *M. hamatum* Willd. magis approximât *M. vaginatum* Nob., et locum ante illud obtinet.

Obs. Ut in Capensibus aliis, staturâ variat.

β , ferè duplò gracilius, eâdem altitudine.

Sectio, AUREA.

Species.

cymbifolium. *M.* (greater boat-leaved), foliis cymbiformibus
3. pallidè viridibus grandipunctatis, ramis paucis ancipitibus canis.

Floret

G. H. h.

Obs. Species distinctissima, nulli valdè affine. Suffrutex secundo

secundo tertiove anno pedalis suberectus, ramis gracilibus paucis, et ferè durissimis.

Folia vix uncialia ferè omninò distincta, seu basi supernè solùm minimè coalescentia, trigona, sed valdè compressa et ventricosè carinata (inde cymbiformia) obtusula, cum mucronulo exiguo albo recurvulo. Nondum produxit flores, locus exactus ergo in systemate nonnihil dubius, at ob foliorum singularem insertionem fortè pone *M. glaucum* est.

Sectio. CORALLINA.

Species.

productum. M. (great-cupped), floribus terminalibus ternis:

4. foliolis calycinis duobus altè productis.

Floret Jul. Aug. G. H. $\frac{1}{2}$.

Descriptio. Suffrutex firmus erectus ramosus secundo anno pedalis, cortice lævi castaneo badiove. *Folia* affinium more ramulorum apicibus conferta subuncialia subincurvo-recurvula obsolete trigona, sæpiùs plùs minùs glaucescentia, angulis obtusissimis; ad lucem pellucenter punctulata, punctulis sub lente rotundatis confertis distinctis, aliis (punctis) quàm cæteris duplò majoribus: apicibus (foliorum) subinde abruptè acutéque recurvulis. *Flores* terminales ternati, rariùsve solitarii, antemeridiani mediocres inodori; in plantis pedalibus quasi paniculati, et super pedunculos curvatos bibracteatos insidentes; *bracteis* infra pedunculi medium, et omninò sed dimidiatim foliiformibus. *Calyx* (cum germine) turbinatim obpyramidalis, foliolis quinque; horum duobus exterioribus quàm cæteris duplò plùsque longioribus et valdè foliiformibus; tertio, quarto, quintoque ordinariis, at parùm longis. *Corolla* dilutissimè rosea, *petalis* valde inæqualibus, interioribus (pedetentim) omninò filamentiformibus. *Filamenta* vera *antheras* parvas polliniferas erectas stramineas finientia. *Styli* quinque erecti lanceolati ramentacei lutei, inter filamenta duplò longiora reconditi. *Capsula* magna turbinata quinquelocularis.

Obs. Nulli maximè affine, sed *Mesem. stipulaceo* fortè magis approximatus, et ante id sine dubio locarem.

Sectio. PLANIFOLIA.

† Calycibus subpyriformibus, &c. *Nob. Revis. Plant. Succ.* 167.

Species.

crassicaule. M. (flat-leaved, strumous,) foliis lorato-acuminatis

5. viridibus glabris; caudice brevissimo crasso.

Floret Maio. G. H. 7.

Descriptio. *Caudex* senectus carnosus-incrassatus subramosus (tertio anno) vix uncialis, subrotundatus ramiferus. *Rami* pauci crassi biunciales expansi. *Folia* conferta affinium more, viridia incurva, denique sæpè recurvula, et inter crassiora (suæ sectionis). *Flores* antemeridiani terminales ternati pallidè lutescentes ut in affinibus, verno tempore, *stylis* ferè nullis. *Peduncululi* quadri-sexve-bracteati, *bracteis* plus minùs remotis, per paria foliiformibus, a calyce semper distantibus. *Foliola calycina* quinque, horum quatuor ferè æqualia, quintum quàm cætera minus. Vidi imprimis in Regio Horto Kewense, A. D. 1822.

Obs. Post *Mesem. pallentem* Aitoni cui simile certè locandum.

Instantèr dignoscitur strumoso caule foliisque planis viridibus.

Sectio, DIGITIFLORA.

Species.

acuminatum. M. (long-cupped), foliis acuminatis viridibus,
6. foliolis calycinis duobus altè productis.

Floret Aug. Sept. G. H. 7.

Descriptio. Suffrutex 1—2-pedalis erectus (vel foliorum onere sensim dejectus), ramis numerosis erectioribus. *Folia* valdè numerosa, in adultis e trigono-semiteretia, breviter acuminata. *Flores* solitarii terminales mediocres. *Corolla* antemeridiana nitidè nivea, demùm rubedinis minutissimâ tincturâ, externè præcipuè. *Petala* affinium more angustissima. *Filamenta* et antheræ spuria, exteriores albæ. *Filamenta* vera breviora, antheris aurantiis polliniferis, petalis triplò humiliora. *Styli* quinque erecti subulati albi, internè planati, antherarum altitudine. *Germen* est conum obtusissimum quinquangulare.

Obs. Post *Mesem. sulcatum* Nob. cui simile, sine dubio locandum, sed ab eo discrepat caulibus gracilioribus debilioribus, foliis erectioribus longioribus et fortè crassioribus sive minùs planatis; et ab omnibus (suæ sectionis) facilè dignoscitur foliolis duobus calycinis foliiformibus quàm cæteris acuminatim 2-3-plò longioribus.

Sectio, SPINULIFERA.

Species.

longispinulum. M. (rosy-cupped yellow), ramis procumbentibus, basi nodoso-strumosis: foliorum spinulis elongatis.

Floret

Floret Aug.—Nov. G. H. ½.

Descriptio. Suffrutex dodrantalis, ramis paucis teretibus sæpiùs procumbentibus, apicibus assurgentibus; caudice nodisque infimis ramorum senectute incrassatis, et sæpè spinulas 5—7 lineares (e persistente costâ foliorum) gerentibus. *Folia* subuncialia et internodiis longiora, linearia canaliculata viridia, obsolete papuloso-nitentia uti ramuli juniores. *Flores* antemeridiani terminales sæpè solitarii, pedunculis validis longis tereti-clavatis adscendentibus. *Calyx* foliolis quinque subæqualibus ordinariis, membranis ante florescentiam plùs minùs roseis; *petalis* pallidè flavis stramineisve; more affinium angustis, interioribus pedentim minoribus subantheriferis. *Stamina* seu filamenta paululùm sensimque patentia, antheræque luteo colore saturiores quàm petala. *Styli* quinque erecti itidem saturiores luteo, staminibus breviores. *Germen* seu capsula pulposa 5-ocularis, embryonibus pauculis pallidis. Ante *M. tenuiflorum* Jacq. locandum.

Sectio, JUNCEA.

Species.

granulicaule. *M.* (shagreen-stemmed) ramis teretibus, granulato crebrè punctatis.

Floret G. H. ½.

Suffrutex ramosus, omnium, *M. tenui* Nob. excepto, gracillimus, primi anni erectus dodrantalis, facie *M. juncei* Nob., cui certè naturali systemate proximum.

Descriptio. Rami articulati asperiusculi, ramulis glaucescentibus. *Folia* subsemuncialia angustissima obtusa glaucescentia internodiis longiora subincurvo-erecta, obtusa subglaucescentia; vel obsolete trigona semiteretiusculave, angulis marginibusve sub lente minutè granulato-asperiusculis: juniora obsolete canaliculata ut in plurimis; seniora denique marcescentia subpersistencia. Verbo tenus specifico nomine satis ab affinibus suæ sectionis dignoscitur.

Sectio, TRICHOTOMA.

Species.

subincanum. *M.* (White-flowered, soft-leaved), foliis expansis compresso-trigonis subcanescentibus mollibus, apice recurvis mucronulatis.

Floret Aug. Sept. G. H. ½.

Descriptio.

Descriptio. *Frutex* firmus ramosus erectus bipedalis ultrève, ramis teretibus. *Folia* subuncialia lævia crassiora quàm in affinis, apice obtuso mucronulo reflectente (quasi externo) ab imâ parte apicis singuli folii. *Folia* juniora molliter incanescentia (uti ramuli incipientes) et sub lente optimo obsolete puberula: seniora viridiora sed mollia tactu. *Flores* antemeridiani mediocres (at magni maximive suæ sectionis) nivei terminales sæpè ternati. *Stamina* filamentis in conum concinnè collectis, petalorum vix semialtitudine. *Antheræ* pollinosæ luteæ.

Obs. *Calyx* (cum germine) hemisphæricus, foliolis 5, horum duobus quàm cæteris productum duplò longioribus.

Obs. Nulli multùm affine, sed fortè magis approximât *M. trichotomo* Thunb. quàm cæteris; unde ante id locarem.

Sectio, BARBATA.

Species.

bulbosum. *M.* (bearded tuberous) ramis villosulis, foliis horizontalibus, radice tuberoso.

Floret Aug. G. H. h.

Descriptio. Suffrutex subpedalis, radice senecto lignoso strumosè tuberoso subgloboso supra terram, pomi mediocris magnitudine. *Rami* effuso-decumbentes teretes pubescentes, internodiis folio longioribus. *Folia* viridia numerosiora brevioraque quàm in *M. intonso* Nob. (in *Philosoph. Mag.* Jul. 1824), magisque approximata in juniorum ramorum apicibus, læviora et solùm sub lente villosula, apicibus multiradiatis. *Flores* antemeridiani mediocres hilariter rubicundi observavi in Regio Horto Kewense, sed nondum dissecavi.

Obs. Pone *Mesem. intonsum* Nob. locandum; et radice tuberoso superterraneo facillimè distinguitur ab omnibus, *M. tuberoso* solùm excepto; atque ab eo barbigeris foliis.

LXXV. *Tables for facilitating the Calculation of the Mean Time of the Passage of Stars over the Meridian; for the Use of those who observe by Clocks or Chronometers showing Mean Solar Time. Computed by Mr. P. LECOUNT.*

THE construction of the following tables is this: Let R^* and R^\odot = the right ascension of a star and the sun;

sun; let \mathcal{R}^* MT. be the same diminished by the acceleration of the stars (at the rate of $3' 55''\cdot91$ for 24 hours).

Then will the mean solar time elapsing from the apparent noon to the passage of any star over the meridian = $(\mathcal{R}^* - \mathcal{R}\odot)$ MT.

The mean time at the apparent noon is = equation of time; consequently the mean time at the star's passage = equation of time + $(\mathcal{R}^* - \mathcal{R}\odot)$ MT.; or, \mathcal{R}^* MT. - $(\mathcal{R}\odot)$ MT. - equation of time).

The first quantity is nearly the same all the year; its changes are not affected by the subtraction of the acceleration of the stars. This quantity for the mean position on the 1st of January 1825, is contained in Table I. for the Greenwich stars. For every day in the year there must be applied to it, the difference between the star's mean right ascension on the 1st of January, and its apparent right ascension on the day of observation. The second quantity $(\mathcal{R}\odot)$ MT. - equation of time) changes from day to day $3' 55''\cdot91$. Table II. contains its amount on certain days (for noon at Greenwich), and the multiple of $3' 55''\cdot91$ to be added to find the same for any intermediate day, is easily taken from Table III.; the last figure of the date being always the multiple required to be added to the value for the next preceding day in Table II.

In order to calculate this number for any other meridian, the value for Greenwich is to be $\left\{ \begin{array}{l} \text{increased} \\ \text{diminished} \end{array} \right.$ for $\left\{ \begin{array}{l} \text{western} \\ \text{eastern} \end{array} \right.$ longitude by the proportional part of $3' 55''\cdot91$ for the longitude, which may be done by the common table for the acceleration of stars contained in all nautical and astronomical books. If the number of Table II. to be subtracted from the \mathcal{R} of Table I. exceeds the latter number, add 24 hours to the \mathcal{R} , and calculate the number of Table II. for the next day.

Example.—Required the time of passage of *Sirius* on the 15th of January 1825, in longitude 5 hours west:—

For January 10, by Table II.	19 ^h 15' 40 ^{''} ·95
For 6 days, by Table III.	23 35·46
January 16	19 39 16·41
For 5 hours western longitude, add . . .	49·15
	19 40 5·56

\mathcal{R} . *Sirius* 1st Jan. 1825, by Table I.

= 6^h 36' 20^{''}·84

For app. \mathcal{R} . Jan. 15 . . . + 2·60

	6 36 23·44
Mean time of passage of <i>Sirius</i> , } . . .	10 56 17·88
Jan. 15, in long. 5 ^h west	

TABLE I.*

No.	Names.	H. M. s.	No.	Names.	H. M. s.
1	γ Pegasi	0 4 14.17	24	Arcturus.	14 5 22.22
2	α Cassiopeiæ	0 30 32.53	25	1 } α Libræ	14 38 37.15
3	Polaris	0 58 4.77	26	2 } α Libræ	14 38 48.56
4	α Arietis	1 57 0.54	27	β Ursæ Maj.	14 48 52.74
5	α Ceti	2 52 40.13	28	α Cor. Bor.	15 24 45.07
6	α Persei	3 11 20.82	29	α Serpentis	15 33 6.09
7	Aldebaran	4 25 9.87	30	Antares	16 16 1.20
8	Capella	5 2 56.88	31	α Herculis	17 3 52.28
9	Rigel	5 5 17.81	32	α Ophiuchi	17 23 57.51
10	β Tauri	5 14 22.67	33	γ Draconis	17 49 37.08
11	α Orionis	5 44 45.53	34	α Lyræ	18 27 59.02
12	Sirius	6 36 20.84	35	γ }	19 34 43.55
13	Castor	7 22 12.72	36	α } Aquilæ	19 39 1.11
14	Procyon	7 28 54.68	37	β }	19 43 28.74
15	Pollux	7 33 21.45	38	1 } α Capric.	20 4 38.66
16	α Hydræ	9 17 27.78	39	2 }	20 5 2.34
17	Regulus	9 57 24.65	40	α Cygni	20 32 5.86
18	α Ursæ Maj.	10 51 4.18	41	α }	21 10 55.03
19	β Leonis	11 38 13.10	42	β } Cephei	21 22 51.27
20	β Virginis	11 39 40.02	43	α Aquarii	21 53 11.98
21	γ Ursæ Maj.	11 42 39.70	44	Fomalhaut	22 44 13.55
22	Spica Virginis	13 13 48.76	45	α Pegasi	22 52 17.71
23	η Ursæ Maj.	13 38 23.89	46	α Andromedæ	23 55 25.96

TABLE II.

Month.	H. M. s.	Month.	H. M. s.
Jan. 0	18 36 21.84	July 10	7 11 16.55
10	19 15 40.95	20	7 50 35.62
20	19 55 00.02	30	8 29 54.64
30	20 34 19.18	31	8 33 50.60
31	20 38 15.12	Aug. 10	9 13 9.70
Feb. 10	21 17 34.24	20	9 52 28.80
20	21 56 53.34	30	10 31 47.91
28	22 28 20.59	31	10 35 43.84
March 10	23 07 39.62	Sept. 10	11 15 2.92
20	23 46 58.72	20	11 54 21.93
30	0 30 13.58	30	12 33 41.03
31	0 34 9.58	Oct. 10	13 13 0.05
April 10	1 13 28.71	20	13 52 19.15
20	1 52 47.76	30	14 31 38.17
30	2 32 6.80	31	14 35 34.13
May 10	3 11 25.88	Nov. 10	15 14 53.21
20	3 50 44.92	20	15 54 12.27
30	4 30 4.01	30	16 33 31.31
31	4 33 59.94	Dec. 10	17 12 50.47
June 10	5 13 19.10	20	17 52 9.63
20	5 52 38.20	30	18 31 28.74
30	6 31 57.39	31	18 35 24.62

TABLE III.

Days	M. s.
1	3 55.91
2	7 51.82
3	10 47.73
4	15 43.64
5	19 39.55
6	23 35.46
7	27 31.37
8	31 27.28
9	35 23.19

* The Nautical Almanack not being calculated to 100dths of seconds, the 100dths are not always correct in this table.

LXXVI. *Meteorological Register kept at Wick in the County of Caithness, near the Extremity of Scotland, in the Year 1823.*

Longitude 4° 10' West; Latitude 58° 28' North.

Height of Thermometer above the Sea 45 Feet:—Quarter of a Mile from the Head of the Bay of Wick.

JANUARY.

1823. Jan.	Thermometer.		Barometer at Noon.	Wind.	Weather.
	10 A.M.	10 P.M.			
1	38	39.50	29.8	SE	Windy, and snow showers } Hard gale
2	41.33	42	29.7	SE	Windy and dry } all these
3	42	44.33	29.6	SE	Windy and showery } 3 days
4	44	42.33	29.7	SE	Windy and rain all day; very stormy
5	41.33	39.67	29.9	SE	Windy and dry all day
6	38.33	38.67	30	SE	Windy and rainy; very rough and cold
7	42	41.67	30.1	SE	Moderate, dry and mild
8	40	39.67	30.2	E	Moderate and rainy
9	40.67	40.50	29.9	SE	Moderate and dry (fine day)
10	41	40.67	29.9	S	Moderate do. do.
11	39.67	37	29.9	S	Moderate do. do.
12	35	35.50	29.8	S	Moderate and thick; evening showery
13	37.50	32.50	29.5	N	Moderate and dry; very fine
14	27.50	36	29.3	N	Moderate and hard dry frost; (very fine)
15	35	36	29.7	SE	Sleet showers, and very raw and cold
16	36	35	29.6	N	Dry frost A.M.; snow, ground white P.M.
17	35	30	29.5	N	Hard frost and snow (little snow) fine
18	32.67	36	29.4	NE	Morning, snow showers; afternoon sleet
19	38.67	37	29.6	SE	Fine mild thaw
20	37	36.33	29.9	SE	Thaw with frequent sleet showers
21	27	26	30.1	NW	Hard frost and very fine; a little snow
22	27	29	30.1	NW	Hard frost do. snow
23	19.50	16	30	NW	Hard frost do. do.
24	24	15	30	NW	Hard frost do. do. (very calm)
25	17	31.50	30	S	Hard frost do. do. (evening soft)
26	36.50	36.50	29.9	SE	Fine mild thaw
27	36.50	34.33	29.6	SE	Gentle thaw
28	38.67	42	29.2	S	Gentle thaw
29	42.33	42	28.9	SE	Snow all gone; fine mild day
30	40.67	37.67	29.2	NW	Mild, calm, clear and dry
31	40.33	40	29.3	S	Mild do. do.
Av ^g	35.87	35.81	29.3		

[The above Register, with which we have been favoured by our friend W. S. MacLeay, Esq. being a record of meteorological phænomena at the northern extremity of the kingdom, will be very useful, we conceive, in comparing the climate of distant parts of the island.—EDIT.]

FEB.

FEBRUARY.

1823. Feb.	Thermometer.		Barometer at Noon.	Wind.	Weather.
	10 A.M.	10 P.M.			
1	38·33	34·33	29·3	NE	Sleet and snow showers
2	34	32	29·2	E	Frost and snow showers; ground white
3	30·33	30·33	29·3	NE	Frost do. do.
4	24	30	29·4	NE	Frost do. do.
5	21	12·33	29·7	N	Frost and clear and calm; intense frost
6	33·67	30	29·7	S	Severe snow showers; high wind and drift
7	32·67	33·67	29·3	S	Constant drift and high wind; very rough
8	34	30·50	29·1	N	Calm and fine; much snow on ground
9	35	36	29·1	W	Calm and fine; a very moderate thaw
10	33	32·67	28·9	N	Calm and fine; no thaw
11	37	38·67	28·7	S	Rain A.M.; dry, moderate thaw P.M.
12	36	30	28·4	W	Morning thaw; afternoon frosty
13	35·33	34·67	29·1	W	Fine and clear; frosty
14	36·33	34·33	29·3	N	Fine and clear do.
15	37·33	36	30	N	Fine and clear do.
16	34	37	30·3	N	Fine and clear do. very fine
17	36	35	29·9	S	Windy, dry and frosty
18	37	35·67	29·2	S	Dry A.M.; very windy and rainy P.M.
19	38·67	32·67	28·8	SW	Very fine, clear and dry
20	37	38·33	29·4	SW	Very fine do.
21	40·33	35·33	28·8	S	Very rainy A.M.; fine, complete thaw P.M.
22	38	36	28·9	SW	Very fine clear and dry
23	38	39	29·1	SW	Very fine clear and dry
24	40	38	29·2	NW	Morning wet; afternoon windy and dry
25	40	39·50	29·1	S	Morning fine; evening rough and rainy
26	41	36·33	29	E	Dry clear and fine; evening rough
27	40·33	34·50	29·3	NE	Dry, clear and fine; cold
28	39·67	36·67	29·5	N	Hail showers and cold
Av ^g e	35·64	34·26	29·3		

MARCH.

Mar.					
1	42	39	29·6	NW	Clear with some hail showers
2	44·67	35·50	29·2	NW	Windy and sleet showers; very violent
3	42	36·50	29	W	Windy and rain occasionally; viol. gusts
4	38·50	38	28·5	N	Windy and much rain all day; very rough
5	40	30	29·3	N	Windy and sleet showers; very rough
6	35·67	30·50	29·6	N	Ground white; calm and clear
7	37	37	29·1	S	Hard frost A.M.; day clear and dry; cold
8	35	35·33	28·9	S	Windy and sleet showers all day

Mar.

1823. Mar.	Thermometer.		Barometer at Noon.	Wind.	Weather.
	10 A.M.	10 P.M.			
9	39	39	29.2	SE	Sleet showers A.M.; clear and fine P.M.
10	40	38.33	29.2	SE	Windy and dry A.M.; sleet showers P.M.
11	41.67	38	29.2	SW	Fine, clear and dry
12	43.50	42	29.7	SW	Ditto ditto
13	46	38.33	29.6	S	Clear and showery alternately
14	43.33	40	30.1	SW	Very fine, clear and dry
15	45	40	30.2	SW	Ditto ditto
16	42.33	38.33	29.9	SW	Clear and showery alternately
17	43.33	35	29.7	NW	Windy and hail showers; very rough
18	35	28.33	29.5	N	Ground white; windy, and snow showers
19	35	29.67	29.6	NW	Ditto ditto ditto
20	33.67	34.67	29.2	SW	Morning, snow showers; afternoon, thaw
21	40	43.33	28.7	S	Morning, rainy; afternoon, fine and mild
22	44.50	35.67	28.6	S	Fine, clear and dry
23	37	32.67	29.5	SW	Very fine, clear and dry
24	43.50	43.33	29.8	S	Ditto ditto
25	46	44.33	29.9	S	Ditto ditto
26	41	39.50	29.9	SE	Windy, clear and dry
27	43	41	29.9	SE	Ditto ditto
28	44	42.33	29.9	SE	Ditto ditto
29	45	42.50	29.8	S	Very fine, mild, clear and dry
30	45	41.50	29.6	S	Ditto ditto ditto
31	48	39.50	29.7	SW	Ditto ditto ditto
Av ^{sc}	41.28	37.72	29.47		

APRIL.

Apr.					
1	45.33	45.67	29.5	W	Fine and mild; a few mild showers
2	48.67	43.50	29.2	W	Ditto ditto; afternoon, mild showers
3	41.67	39.33	28.9	NW	Constant rain, and very high wind
4	39.33	34.67	29	NW	Moderate, but showery and clear altern ^y .
5	42	39	29	N	Ditto ditto ditto
6	45.50	37.50	29.5	N	Very fine, clear and dry
7	45.67	42.50	29.8	N	Ditto ditto
8	49	43.50	29.9	N	Very calm, clear and dry
9	45	42.33	30	NE	Ditto ditto
10	44.67	40.50	30.1	S	Ditto ditto
11	46.33	42.67	30.2	S	Ditto ditto
12	48.33	44	30.1	var.	Perfectly calm, clear and dry
13	48.67	42.33	30	S	Calm, clear and dry
14	47	44.50	30	S	Ditto ditto

1823. April.	Thermometer.		Barometer at Noon.	Wind.	Weather.
	10 A.M.	10 P.M.			
15	53	43.50	30.1	SW	Calm, clear and dry
16	51.50	46.33	29.6	NW	Windy, clear and dry
17	47	38.67	29.4	NW	Ditto ditto some showers
18	39	38.50	29.3	N	Morning, ground covered with snow; snow
19	42.33	33.67	29.4	N	Snow showers, and rough [showers
20	41	36.50	29.7	N	Calm, clear and dry; very cold
21	41.67	39	29.8	N	Ditto ditto very fine
22	43	38.50	29.7	S	Fine, clear and dry
23	40.50	38.50	29.6	S	Morning, showery; afternoon, clear & dry
24	42.33	35.67	29.6	N	Frequent hail showers, and very cold
25	41	33.67	29.7	N	Ditto ditto
26	45	38	29.8	N	Ditto ditto
27	42.50	41.50	29.9	N	Fine, clear and dry
28	41.50	40	29.7	NW	Showery, and very rough
29	49.50	43.67	30	NW	Fine, clear and dry
30	54	50	29.9	SW	Windy, clear and dry
Av ^{ge}	45.07	39.28	29.66		

MAY.

May					
1	52	50	30.1	W	Windy, clear and dry; morning showery
2	55.67	46	30.1	W	Ditto ditto
3	47.67	42.33	30.3	N	Clear, dry and cold
4	43.67	43	30.3	S	Ditto ditto
5	50.50	48	29.8	SW	Morning showery; afternoon clear & dry
6	54.50	47	29.8	S	Fine, clear and dry
7	49	45.67	29.6	E	Morning very fine; evening rainy
8	54	44	29.2	NE	Morning very fine; evening showery
9	47.33	41.33	29.3	N	Morning showery; evening showery and
10	48.67	43.33	29.6	SE	Very fine, clear and dry [windy
11	40.67	44	29.2	SE	Constant rain all day
12	52.67	44.33	29.1	SE	Mild, and thick fog all day
13	44.67	42	29	NE	Excessive rain all day; very rough
14	43.67	43	29.3	NW	Morning rainy; afternoon fine and dry
15	45.67	44	29.6	NW	Windy, clear and dry
16	48.33	52	29.3	SW	Morning rainy; evening fine and dry
17	46	40	29.3	W	Windy and showery; very rough
18	47.33	44	29.6	W	Ditto ditto
19	56	47	29.7	SW	Very fine, clear and dry; calm
20	53.50	45.33	29.7	E	Fine, clear and dry
21	48.50	45.50	29.7	E	Morning fine and dry; evening rainy

May

1823. May.	Thermometer.		Barometer at Noon.	Wind.	Weather.
	10 A.M.	10 P.M.			
22	51	48·33	29·6	S	Morning foggy; afternoon fine and dry
23	51·33	45·67	29·5	S	Morning rainy; noon and evening foggy
24	51·50	46·50	29·6	SE	Morning foggy; afternoon rainy
25	51	48·50	29·6	E	Morning foggy; afternoon rainy
26	49·50	48	29·7	E	Morning foggy; afternoon fine
27	54	48·33	30	E	Fine, clear and dry
28	54	48·50	30	S	Ditto ditto
29	55·50	49·50	29·9	W	Morning rainy; afternoon fine and clear
30	58·50	51·50	30	SW	Fine, clear and dry
31	58	50·50	30·1	NW	Ditto ditto very fine
Av ^{ge}	50·46	46·04	29·66		

JUNE.

June					
1	53·50	49·50	30	S	Rough and showery
2	55·50	45·50	29·2	W	Strong gale and showery
3	50	45·50	29·1	W	Windy and showery
4	50	48·50	29·1	S	Fine, clear and dry
5	52	50·33	29·2	S	Very fine, clear and dry
6	57·67	52	29·6	N	Calm; very fine, clear and dry
7	51·33	49·67	29·5	S	Showery
8	55·67	51	29·4	SW	Fine, clear and dry
9	59	48·33	29·6	SW	Calm and rainy
10	54	46	30	N	Very calm, fine and dry
11	54	51·50	29·9	N	Ditto ditto
12	61	57	29·8	W	Very fine and dry
13	63	48	29·6	NW	Windy and clear
14	54·67	43·67	29·7	W	Ditto ditto evening showery
15	51	44·33	30	N	Windy and showery; rough and cold
16	53	48·50	30·1	N	Windy and dry
17	53·50	48·50	30·2	N	Fine, clear and dry
18	52·67	50·50	30·3	N	Ditto ditto
19	52·33	51·67	30·2	N	Ditto ditto
20	54·50	48·33	30·2	N	Ditto ditto
21	53	45·50	30·2	N	Ditto ditto
22	52·67	42·33	30·2	N	Ditto ditto
23	53·67	45·33	30	N	Ditto ditto
24	54·67	43	29·6	S	Mild and showery
25	47·67	41·67	29·3	S	Calm and showery, hail showers
26	51·50	42·67	29·4	N	Morning rough; aftern. calm & showery
27	53·33	51	29·4	S	Calm and showery

1823. June.	Thermometer.		Barometer at Noon.	Wind.	Weather.
	10 A.M.	10 P.M.			
28	55.50	49	29.3	S	Very calm, clear and foggy alternately
29	56.	51	29.9	N	Very calm, clear and fine
30	54.50	52.33	29.9	S	Ditto ditto
Av ^{se}	54.03	48.27	29.73		

JULY.

July					
1	56	46	29.9	N	Fine rain; evening dry and clear
2	51.50	49	29.4	N	Fine, clear and dry
3	54	49	30	NW	Cloudy and dry
4	59	51.33	29.9	S	Ditto ditto
5	59	54.67	29.2	S	Rain all day
6	59.50	50.33	29.1	SW	Cloudy and fine
7	56.50	51.33	29.3	N	Cloudy and very fine
8	57	50.50	29.6	N	Showery and calm all day
9	55	48.50	29.8	N	Cloudy and dry
10	60	52.50	29.8	S	Ditto ditto
11	57.50	52.67	29.2	SW	Rainy and calm
12	56	52	29.2	N	Cloudy and calm
13	55	52.50	29.3	SW	Rainy and calm
14	53	50.67	29.4	N	Cloudy and dry
15	59	51.50	29.5	SE	Forenoon fine and dry; afternoon rainy
16	54	47.33	29.5	N	Cloudy, windy and cold
17	55.50	51.33	29.6	N	Clear, dry and fine
18	56	51	29.6	SE	Rainy all day
19	58.33	57.67	29.5	S	Ditto ditto
20	62	53	29.4	S	Fine and dry
21	63	56	29.3	SW	Very fine and dry
22	59.33	53.33	29.4	N	Rainy and calm all day
23	62.50	52	29.4	S	Calm and clear; very fine
24	55.67	47.33	29.5	NW	Windy and dry
25	55	51.50	29.6	S	Fine clear and dry
26	59	52	29.6	S	Forenoon fine & dry; afternoon showery
27	56.67	54	29.8	SE	Fine, clear and dry
28	56.67	53.67	29.5	S	Ditto ditto
29	60.50	53.67	29.5	S	Ditto ditto
30	60	53	29.5	SW	Ditto ditto
31	58.50	54.33	29.7	S	Ditto ditto
Av ^{sc}	57.44	51.73	29.51		

AUGUST.

1823. Aug.	Thermometer.		Barometer at Noon.	Wind.	Weather.
	10 A.M.	10 P.M.			
1	60.50	53.67	29.7	SW	Morning fine; afternoon showery
2	61.50	53	29.6	S	Warm and slight showers
3	61.67	51.67	29.6	NW	Forenoon very fine; evening rainy
4	50.50	44.33	29.2	NW	Forenoon heavy rain; evening fine
5	57	46	29.8	NW	Rainy and rough all day
6	51	46	29.3	W	Showery all day
7	51	50	29.3	W	Showery and rough all day
8	60.50	51	29.4	SW	Fine, clear and dry
9	56.50	51.33	29.8	SW	Ditto, ditto very fine
10	55.50	57	29.6	S	Showery and mild
11	65.50	54	29.4	SW	Forenoon fine; afternoon very rainy
12	63.50	52.67	29.3	W	Forenoon rainy; afternoon clear & fine
13	60.33	54.50	29.6	SE	Very fine, clear and dry
14	54.67	49	29.8	N	Rainy all day
15	59	50.50	29.4	W	Very fine, clear and dry
16	58.50	48	29.3	W	Ditto ditto
17	58.33	49.50	29.6	SW	Calm, and very heavy showers of rain
18	54.33	54	29.7	SE	Fine, clear and dry
19	60.67	54.67	29.3	S	Ditto ditto
20	56.50	52	29.4	SW	Ditto ditto
21	58	50.50	29.5	SW	Ditto ditto
22	60	51	29.6	SW	Ditto ditto
23	56.50	51	29.6	SW	Ditto ditto; evening showery.
24	62	52	29.8	S	Ditto ditto
25	54.50	48.33	29.6	NE	Rainy all day
26	59.50	51.33	29.9	SE	Fine, clear and dry
27	58	54.33	29.9	SE	Forenoon windy; afternoon rainy
28	59.67	53.67	29.8	S	Fine, clear and dry
29	59.33	53.67	29.8	S	Ditto ditto
30	61	51	29.7	S	Morning fine; afternoon heavy showers
31	57	51.67	29.9	S	Fine, clear and dry
Av ^{ge}	58.15	51.37	29.59		

SEPTEMBER.

Sep.					
1	57	55.50	29.8	SE	Forenoon fine; afternoon rainy
2	59	49	29.5	SW	Fine, clear and dry
3	59	50.50	29.5	NW	Showery and windy
4	56	52.67	29.6	NW	Morning rainy; afternoon fine and windy
5	55	49	29.8	N	Calm and showery
6	51.67	47.67	30	N	Calm and dry

Sept.

Sept. 1823.	Thermometer.		Barometer at Noon.	Wind.	Weather.
	10 A.M.	10 P.M.			
7	50.33	47	30.2	N	Calm and dry
8	51	49	30.1	W	Ditto ditto
9	57	54	29.9	W	Morning calm and dry; evening rainy
10	57.67	54.33	30.1	W	Cloudy, calm and dry
11	53.67	53	30.1	SE	Foggy, calm and fine
12	58	54.33	29.8	SE	Hazy and rough; evening rainy
13	55.50	47.50	29.6	SE	Fine, clear and dry
14	55.67	55	29.5	SE	Morning windy and clear; evening hazy
15	56	51.50	28.8	SE	Heavy rain all day
16	55.50	53.50	29.3	S	Forenoon clear and dry; evening rain &
17	57.50	49	29.3	SW	Fine, clear and dry [wind
18	54	57.33	30	W	Ditto ditto
19	56.50	48	29.7	SW	Ditto ditto
20	53.50	47	29.7	SW	Ditto ditto [rainy
21	50	47.67	29.4	SW	Morning cloudy and dry; evening very
22	52.33	44.67	29.4	N	Cold, dry & clear; incessant rain at night
23	47.33	50	29.5	SW	Cold and showery; very rainy all day
24	55.50	49	29.3	W	Cold and showery
25	56.67	48.50	29.3	W	Incessant rain all day
26	48.67	41.67	29.4	W	Windy and some showers
27	49	37.67	29.4	W	Cold and frequent severe showers
28	46.50	40.33	29.8	W	Cold and showery
29	48	48.67	29.6	SW	Windy and showery
30	47.50	36.50	29	W	Calm and showery
Av ^c	53.7	48.98	29.61		

OCTOBER.

Oct.					
1	42.50	42	29.1	NW	Calm and showery
2	42	44	29	NW	Rough and rain all day
3	49.50	47.50	29.4	SW	Calm and cloudy; evening rainy
4	48.50	42.67	29.6	SW	Calm and fine all day
5	51.50	52.33	29.4	SE	Very windy and incessant rain; very
6	56	49.33	29.4	S	Fine, clear and dry [stormy
7	54.33	46	29.6	S	Fine morning; afternoon showery
8	51.50	47.33	29.5	S	Morning fine and dry; evening showery
9	46.67	44.67	29.2	S	Very fine and clear all day
10	47	48	29	S	Windy, clear and dry
11	47	48	28.9	E	Very windy and constant rain
12	51.50	47.50	29.2	E	Morning cloudy and dry; evening rainy
13	50	47.33	29.4	N	Morning fine, clear & dry; evening rainy
14	49.67	48.67	29.2	NW	Morning rainy; afternoon fine
15	49.67	50.67	28.9	NW	Rainy all day

Oct.

1824. Oct.	Thermometer.		Barometer at Noon.	Wind.	Weather.
	10 A.M.	10 P.M.			
16	51	50.50	29.2	NE	Showery and rough all day
17	50.67	49.33	29.8	NE	Ditto ditto
18	51	49	29.3	NE	Showery and fine alternately
19	47	44.33	29.8	N	Clear and dry; evening showery
20	48.50	47	30.2	E	Clear and dry all day
21	49	47.33	30.3	S	Windy, clear and dry
22	49.33	46	30.1	S	Ditto ditto
23	49	48	30	S	Ditto ditto
24	50	44.33	30	N	Calm, clear and dry
25	47.50	43.50	30.2	W	Ditto ditto
26	50.50	39	30.2	W	Ditto ditto
27	50.50	51.50	29.7	S	Ditto ditto
28	44.33	41.67	29.4	NW	Windy and showery
29	40	34.50	29.3	SW	Windy and sleet, showery
30	37.67	38.50	29.2	NW	Windy and sleet, showery; very stormy
31	39.50	33	29.8	NW	Windy and dry
Av ⁵⁰	48.12	45.59	29.49		

NOVEMBER.

Nov.					
1	39	42.67	29.8	SW	Fine & frosty A.M.; calm, clear & dry P.M.
2	47	49	29.7	S	Windy and dry
3	50.33	49	29.5	S	Calm and dry A.M.; damp and hazy P.M.
4	48.50	51	29.4	SE	Calm and damp A.M.; rainy P.M.
5	50.33	50.50	29.7	E	Calm and hazy
6	50	50.33	29.9	E	Ditto ditto
7	48	49	30	S	Calm, cloudy and dry
8	47.50	47	30.3	N	Ditto ditto
9	42.67	33.33	30.4	E	Calm, clear and dry; very fine
10	42	40.50	30.4	S	Ditto ditto ditto
11	44	45	30.3	S	Calm, cloudy and dry; very fine
12	41.33	44.67	30.1	S	Calm, clear and dry; very fine
13	47.50	47	29.9	W	Cloudy and damp
14	48	48.50	30	NW	Thick rain all day
15	48.67	48.50	30.1	NW	Cloudy all day
16	43	46.50	30.1	W	Clear and dry all day
17	46.50	40	30.1	NW	Windy, clear and dry
18	41.33	41.50	30.2	SW	Calm, clear and dry; very fine
19	41.50	42.67	29.7	SW	Morning showery; afternoon dry & cloudy
20	46.50	51	29.5	W	Cloudy and damp all day
21	50	46	29.5	W	Ditto ditto
22	45	47	29.6	W	Calm and thick rain all day
23	48	46.50	29.6	W	Calm and cloudy all day

1823. Nov.	Thermometer.		Barometer at Noon.	Wind.	Weather.
	10 A.M.	10 P.M.			
24	47.33	49	29.5	SW	Windy and showery
25	51.33	53	29.6	SW	Windy and dry
26	53	48.50	29.6	SW	Ditto ditto
27	50	50.50	29.5	SW	Ditto ditto
28	44	42.33	29.5	SW	Ditto ditto
29	44	47.67	29.1	S	Windy & rough all day; evening showery
30	45	38.50	28.6	S	Ditto, clear and dry
Av ^{ge}	43.37	46.22	29.77		

DECEMBER.

Dec.					
1	42.67	38	28.3	SW	Windy, and hail showers; very stormy
2	38.50	33	29.1	SW	Fine, clear and dry all day; calm
3	31	40.67	29	NW	Very fine, and hard frost A.M.; even ^s soft
4	42.67	39	28.9	NE	Cloudy and raw
5	37.50	36.33	29.4	W	Ditto ditto
6	33	36.33	29.7	SW	Frosty A.M.; evening fresh; calm all day
7	42	49	29.8	W	Windy and raw all day; even ^s very windy
8	44	34	29.6	W	Very windy, and sleet showers; stormy
9	33.50	26.33	29.8	W	Ditto ditto ditto
10	38.67	45.50	29.9	SW	Moderate and cloudy
11	39	34	29.2	SW	Windy and showery; rough
12	32.50	36	29	NW	Windy, & snow showers A.M.; even ^s hard
13	38	36.67	29.8	SW	Moderate and showery [gale
14	37	38.50	29.9	SW	Ditto ditto
15	34.67	42	29.7	SW	A little frost A.M.; fine, clear and dry P.M.
16	43	37.50	29.4	SW	Fine, clear and dry; very mild
17	39.33	33	28.9	SW	Windy and dry [snow
18	32.33	27.33	28.3	N	Fine, calm and frosty; ground white with
19	24	35.50	29.4	W	Fine, and frosty A.M.; even ^s thaw, g ^d white
20	40	42.67	29	SE	Strong wind, and showery; snow all gone
21	42	42	29.4	E	Calm, damp and cloudy
22	35	38.50	29.6	SW	Calm, clear and dry; very fine
23	40.67	40.50	29.5	SW	Ditto ditto ditto
24	37	45.33	29.6	SW	Calm, cloudy and damp
25	45.67	46.33	29.4	SE	Calm, thick and soft; very mild
26	38.33	40.67	29.7	W	Windy and dry
27	45	38.67	28.9	S	Morning rain; evening fair and mild
28	37.67	43.50	28.9	E	Morning fine; evening rain and wind
29	40	40	28.5	S	Fine, clear and dry all day
30	39	41	28.5	W	Ditto ditto ditto
31	40	34	29.1	N	Calm and showery
Av ^{ge}	38.18	38.77	29.26		

LXXVII. *On a Hydro-pneumatic Pump.* By Mr. S. SEAWARD.

To the Editors of the Philosophical Magazine and Journal.

Gentlemen,

FROM the Notices to Correspondents contained in a late Number, I observe that the letter I had the honour of addressing to you, in vindication of my claim to the invention of the Hydro-pneumatic Pump, has been refused insertion in your valuable work, partly because it did not offer any "proofs."

I beg to acquaint you that, in consequence of my being stationed in a distant part of Cornwall, I am precluded, for the present, from collecting the necessary evidence, which on my return to London I shall have no difficulty in obtaining, to the full establishment of my claim.

In the mean while permit me to offer to your notice two or three facts which can be easily verified.

Having conceived the idea of compressing gas by the medium of a liquid body, I submitted my first ideas to paper, in the form of sketches, long before I had any communication with Mr. Martineau on the subject. This document is now and constantly has been in the possession of my brother, who will be happy to show it to any person who is inclined to give it an examination. It is true my first plan differed materially in form and size from the pump afterwards made, although in principle it will be found substantially the same.

I afterwards, with the advice of my brother, arranged and planned the pump in all its essential features, both as to size and disposition of parts, exactly as described in your Number for July.

This plan I submitted to Mr. Martineau, and explained to him the nature of the machine, with its intended operation; and now I can solemnly aver, that up to this time neither myself nor any person whom I consulted had the slightest idea that any thing of the kind had ever been suggested before.

However, I was now informed that Mr. David Gordon of the Portable Gas Company had already proposed a pump on similar principles, and had published his ideas on the subject, about four years ago, in the *Repertory of Arts*. As soon as I was acquainted with this fact, I waited upon that gentleman to ascertain whether he intended to pursue the idea any further; he candidly informed me he did not, but wished me success in my endeavours, as he approved my plan.

From this period, no time was lost in proceeding with the pump, which was made and completed entirely under my management and direction, as must be notorious to everybody in Mr. Martineau's factory. If the above facts be correct,—

and they admit of easy proof,—I will leave it to the judgement of any impartial man whether I have been guilty of falsehood in claiming the invention, qualified as that claim is by a proper acknowledgement of Mr. D. Gordon's priority.

I beg here to observe, that in publishing a description of the pump in question, I had not the slightest idea of giving any offence to Mr. Martineau, as such publication was actually contemplated by me while I was in his employ. You, Gentlemen, may remember that I promised you the description of this pump at the time I furnished you with the account of my *high pressure gauge*: at that period I considered myself in the enjoyment of Mr. Martineau's approbation and confidence. I have also to remark, that when he wished to make me a compensation for an invention of mine, I unhesitatingly refused to take any reward, as I considered myself bound, while in his employ, to do every thing in my power to promote his interests,—a conduct on my part which I conceive was deserving of a different return from the one I have met with.

I will now beg to ask Mr. Martineau, who the person is that he conceives is entitled to the credit of the invention; who was the person who suggested the "*essential parts of the pump*," and what these are; who instructed or directed me in preparing the drawings for the same; and also whether any machine of the kind was ever made or attempted in his or any other factory before I submitted to him my plan? If he will candidly answer the foregoing queries, it may be the means of throwing some light upon this mystery. Your kind insertion* of this will particularly oblige

Yours, &c.

Cornwall, Nov. 13, 1824.

SAMUEL SEAWARD.

LXXVIII. *Analyses of a Series of Papers on the Structure, Distribution, and Functions of the Nerves; by CHARLES BELL, Esq.; which have appeared in some late Volumes of the Philosophical Transactions.*

[Concluded from p. 359.]

WE were engaged in our last Number in considering the provision which exists for preserving the eye-ball from injury by the involuntary winking of the eyelids, as pointed out by Mr. Bell, and which instinctive action was seen to depend on some minute branches of the portio dura of the face supplying those parts: but the author, in the first part of the pa-

* We have inserted this letter in compliance with an urgent claim made on us on the part of Mr. Seaward, although, as the apparatus has we learn failed to answer the purpose for which it was intended, the subject has ceased to be of public importance.—EDIT.

per on this subject, took occasion to observe that the shutting of the eyelids was not the only part of this act of preservation, for the motions of these are at the same time attended with a rolling of the eye-ball. The question, how is this relation between the eyelids and eyeballs established? leads therefore to an examination of the fourth nerve.

“The fourth Nerve.

“This is a fine nerve, which take its origin from the brain, at a part remote from all the other nerves which run into the orbit. It threads the intricacies of the other nerves without touching them, and is entirely given to one muscle, the superior oblique. We may observe too, that this singularity prevails in all animals. What office can this nerve have in reference to this one muscle? Why is its root, or source, different from the other nerves, from the nerve of vision, the nerve of common sensibility, and the nerve of voluntary motion? We now reflect, with increased interest, on the offices of the oblique muscles of the eye, observing that they perform an insensible rolling of the eyeball, and hold it in a state of suspension between them. We have seen that the effect of dividing the superior oblique was to cause the eye to roll more forcibly upwards; and if we suppose that the influence of the fourth nerve is, on certain occasions, to cause a relaxation of the muscle to which it goes, the eyeball must be then rolled upwards*.

“The course of inquiry leads us, in the next place, to observe the vicinity of the root of this fourth nerve, to the origin of the respiratory of the face, and we find them arising from the same track of fibrous substance. The column of medullary matter which constitutes that part of the medulla oblongata from which the respiratory nerves arise, terminates up-

* “The nerves have been considered so generally as instruments for stimulating the muscles, without thought of their acting in the opposite capacity, that some additional illustration may be necessary here. Through the nerves is established the connexion between the muscles, not only that connexion by which muscles combine to one effort, but also that relation between the classes of muscles by which the one relaxes while the other contracts. I appended a weight to a tendon of an extensor muscle, which gently stretched it and drew out the muscle; and I found that the contraction of the opponent flexor was attended with a descent of the weight, which indicated the relaxation of the extensor. To establish this connexion between two classes of muscles, whether they be grouped near together, as in the limbs, or scattered widely as the muscles of respiration, there must be particular and appropriate nerves to form this double bond, to cause them to conspire in relaxation as well as to combine in contraction. If such a relationship be established, through the distribution of nerves, between the muscles of the eyelids and the superior oblique muscle of the eyeball, the one will relax while the other contracts.”

wards, or at its anterior extremity, just under the corpora quadrigemina, and there the fourth arises. Is it possible then, we say, that there can be any correspondence between the general act of respiration, and the rolling of the eye? Led thus to make the experiment, I was gratified to find it so easy to give the proof. On stopping the nostrils with the handkerchief, every effort to blow the nose will be attended by a rapid rising of the cornea under the upper eyelid. And on every occasion when the eyelids suffer contraction through the agency of the respiratory nerve of the face, as in sneezing, the eyeball is rolled upwards through the agency of the fourth nerve.

“It is plain that we must consider the nerves and muscles of the eyelids in a double capacity, in their voluntary, and involuntary actions. In the first, the motions of the eyelids combine with the whole muscles of the eyeball, as we may perceive in the voluntary contractions and squeezing of the eye; but in the insensible and involuntary motions of the eyelids, there would be no sympathy with the muscles of the eyeball, and therefore no correspondence in the motion of these parts, without a nerve of the nature of the fourth; that is, a nerve which having diverged from the root of the respiratory nerves, takes its course to the oblique muscles. In one word, the connexion of its root declares the office of this nerve.

“The expression of the eye in passion, confirms the truth of this relation being established by a respiratory nerve, and consequently by a nerve of expression. In bodily pain, in agony of mind, and in all this class of passions, the eyes are raised and dragged, in conjunction with the changes to which the other features are subjected. If it be asked now, as it has been asked for some hundred years past, why the fourth nerve goes into the orbit, where there are so many nerves, why it is so distant in its origin from the other nerves, and why it sends off no twig or branch, but goes entirely to one muscle of the eye? The answer is, to provide for the insensible and instinctive rolling of the eyeball; and to associate this motion of the eyeball with the winking motions of the eyelids; to establish a relation between the eye and the extended respiratory system: all tending to the security or preservation of the organ itself.

“Of the voluntary Nerves.

“The voluntary nerves of the eye are the third and sixth. The third nerve arises from the crus cerebri, that track of medullary matter which gives off all the nerves purely of volition. It is given to the muscles of the eye generally, and to no part but muscles. For these reasons we retain the name

motor

motor oculi, given by Willis, although his reasons for calling it so were fanciful and unsatisfactory. The fifth nerve, by its ophthalmic division, gives branches to the muscles of the eye, but not so profusely as to the surrounding parts; and not more than sufficient to give them sensibility in the degree possessed by muscular substance generally. Since the branches of this fifth nerve, transmitted to the muscles of the eyelids and forehead, do not minister in any degree to muscular action there, it would be unwarrantable to suppose that they served the purpose of giving action to the muscles within the orbit. For these reasons, I conceive the third nerve to be that which gives volition to the muscles of the eye, and that it is, of all the nerves of the body, the most perfectly and directly under the power of the will.

“The *sixth nerve* is called *abducens*, and *motor externus*. With regard to its origin and distribution, there is no obscurity in this nerve; it arises from the same track of medullary matter which gives rise to the motor nerves, and it is distributed to a voluntary muscle, the *rectus externus*. In this respect it is like a subdivision of the third, and without doubt it is a voluntary nerve; but there is a circumstance in its connexion which I cannot explain. It receives a gross branch from the great visceral nerve called Sympathetic. This nerve, ascending through the base of the skull, unites with the sixth nerve as it is entering the orbit. Some having proceeded so far, would be inclined to call this an accidental connexion, and so leave it; but similar investigations, for many years, have brought me to the conviction that there is no accident in an animal body; and Comparative Anatomy proves this to be a regular established relation.

“To return to the consideration of these nerves of volition as they regard the eye, we may affirm, that although they want sensibility in the common acceptation of the term, they no doubt furnish the mind with the rudiments of certain sensations, and so far resemble the nerves of the senses. From experiments narrated in the first part of this paper, it appears, that we are sensible to the degree of agency exercised by the voluntary muscles of the eye. These nerves, the third and sixth, although they receive no external impression, are nevertheless agents which give rise to the perceptions of place or relation, in aid of that sensibility enjoyed by the optic nerve and retina.

“I hope I have now unravelled the intricacy of the nerves of the head, and have correctly assigned to each nerve its proper office. In our books of Anatomy, the nerves are numbered

bered according to the method of Willis, an arrangement which was made in ignorance of the distinct functions of the nerves, and merely in correspondence with the order of succession in which they appear on dissection.

“The first nerve is provided with a sensibility to effluvia, and is properly called olfactory nerve.

“The second is the optic nerve, and all impressions upon it excite only sensations of light.

“The third nerve goes to the muscles of the eye solely, and is a voluntary nerve by which the eye is directed to objects.

“The fourth nerve performs the insensible traversing motions of the eyeball. It combines the motions of the eyeball and eyelids, and connects the eye with the respiratory system.

“The fifth is the universal nerve of sensation to the head and face, to the skin, to the surfaces of the eye, the cavities of the nose, the mouth, and tongue*.

“The sixth nerve is a muscular and voluntary nerve of the eye.

“The seventh is the auditory nerve, and the division of it, called *portio dura*, is the motor nerve of the face and eyelids, and the respiratory nerve, and that on which the expression of the face depends.

“The eighth and the accessory nerve are respiratory nerves.

“The ninth nerve is the motor of the tongue.

“The tenth is the first of the spinal nerves; it has a double root and a double office; it is both a muscular and a sensitive nerve.

“Had I taken the nerves of any other complex organ rather than of the eye, I should have had an easier task. If I had taken the nerves of the tongue, I should have been able to prove by experiment, and in a manner the most direct, that the three nerves belong to three distinct functions, and stand related to three different classes of parts. I could have shown that taste and sensibility belong to the office of the fifth nerve, voluntary motion to the ninth, and deglutition to the glosso-pharyngeal nerve of the tongue.

“In concluding these papers, I hope I may be permitted to

* “In this view of the fifth nerve, I have not touched upon its resemblance to the spinal nerves. But if we had ascended from the consideration of the spinal nerves to the nerves of the head, we should then have seen that the fifth was the spinal nerve of the head; that it had a ganglion at its root, a double origin, and from its power over the muscles of the jaws and mastication, that it was a double nerve in function, being that nerve which bestows sensibility, at the same time that it sends branches to the original muscles; that is to say, to that class of muscles which are common to animals in every gradation. In all these respects it resembles the spinal nerves.”

offer a few words in favour of anatomy, as a means better adapted for discovery than experiment. The question lies between observation and experiment, and it may be illustrated by astronomy and chemistry. In the first, the objects being beyond the influence of man, he makes observations, not experiments; and the science at length attains a state of perfection which raises our estimate of the human intellect. In the latter, for the most part, the subjects lie out of the sphere of mutual influence; they must be brought together by artifice, and chemistry becomes a science of experiment. But anatomy is more allied to the former than to the latter science, in as much as things are obvious to the eyes. In the animal body the parts present distinct textures, and are laid in a natural and perfect order; it is necessary only to trace the tubes or to observe the symmetrical order of the nervous cords, in order to discover their respective uses: the motions, whether of the solid or fluid parts, are so regular and uniform, that the whole offers a subject for observation and induction. Anatomy is already looked upon with prejudice by the thoughtless and ignorant: let not its professors unnecessarily incur the censures of the humane. Experiments have never been the means of discovery; and a survey of what has been attempted of late years in physiology, will prove that the opening of living animals has done more to perpetuate error, than to confirm the just views taken from the study of anatomy and natural motions.

“In a foreign review of my former papers, the results have been considered as a further proof in favour of experiments. They are, on the contrary, deductions from anatomy; and I have had recourse to experiments, not to form my own opinions, but to impress them upon others. It must be my apology, that my utmost efforts of persuasion were lost, while I urged my statement on the grounds of anatomy. I have made few experiments; they have been simple, and easily performed; and I hope are decisive.

“If we turn to the opinions which have been entertained on the subject of the brain and nerves, we find one theory to have prevailed from the Greek authors to the time of Willis, and to have descended from him with little alteration, to modern writers. The brain has been supposed to secrete and supply a nervous fluid, and the nerves to be the conduit pipes for its conveyance. In every age the brain has been considered a common sensorium, and all the nerves to be capable of conveying sensation, unless when they had ganglia. If ganglia intervened, then the nerves were said to be cut off from the brain; and those so distinguished were called vital nerves, neither serving the

the purpose of governing the muscles, nor of conveying sensation. With all this apparent simplicity of doctrine, there never has been presented such a crude heap of errors, in the history of any department of science.

“These notions were obviously founded on the mistake, that the same nerve served different purposes, and that a fluid moved in the same tube outwards to stimulate the muscles, and inwards to convey sensation of external impressions. So inconsistent are those opinions with the structure of the frame, that the simplest dissection proves them false.

“So far is it from being true that ganglia cut off sensation, that I have ascertained, and proved by experiment, that all the nerves, without a single exception, which bestow sensibility from the top of the head to the toe, have ganglia on their roots; and those which have no ganglia are not nerves of sensation, but are for the purpose of ordering the muscular frame.

“The hypothesis, that the nervous fluid streams out from the great officina along the nerves, has had an unfortunate influence in directing the labours of the experimentalists. During the last age it kept the pupils of Haller engaged in inquiries regarding the influence of the nerves: *de nutritione imprimis nervosa*: and *de nervorum in arterias imperio*; and the interest of this question has not subsided, but, on the contrary, has increased among us.

“This notion of a fluid moving backwards and forwards in the tubes of the nerves, equally adapted to produce motion and sensation, has perpetuated the error, that the different nerves of sensation are appropriated to their offices by the texture of their extremities, “that there exists a certain relation between the softness of the nervous extremities, and the nature of the bodies which produce an impression on them.” On the contrary, every nerve of sense is limited in its exercise and can minister to certain perceptions only. Whatever may be the nature of the impulse communicated to a nerve, pressure, vibration, heat, electricity, the perception excited in the mind will have reference to the organ exercised, not to the impression made upon it. Fire will not give the sensation of heat to any nerve but that appropriated to the surface. However delicate the retina be, it does not feel like the skin. The point which pricks the skin being thrust against the retina, will cause a spark of fire or a flash of light. The tongue enjoys two senses, touch and taste; but by selecting the extremity of a particular nerve, or what is the same thing, a particular papilla, we can exercise either the one or the other sense separately. If we press a needle against a nerve of touch, we shall feel the sharpness, and know the part of the tongue

tongue in contact with the point; but if we touch a nerve of taste, we shall have no perception of form or of place, we shall experience a metallic taste.

“The innovations of the celebrated continental authority Bichat, did not bring us a step nearer the truth. When he at once threw off respect for his contemporaries, and for the authority of those who had preceded him, he equally disregarded the facts of anatomy. There may be merit in taking new views of a subject; but Bichat was continually holding a thing up by the wrong end, and presenting it in an aspect so singular, as to puzzle any one to say whether or not it was that with which he had been long familiar; accordingly, what had been termed the sympathetic system of nerves, he called the ganglionic system; although they are not more distinguishable by ganglia than the other nerves, upon which indeed the ganglia are remarkable for their size, number, and regularity. These ganglia must not be thrown out of the system altogether, merely because they are contained within the skull and vertebræ, which circumstance should rather mark their importance.

“Bichat persuaded himself that his ganglionic system was isolated, and a thing by itself; when, on the contrary, the connexions of this part of the nervous system are universal. The wide spreading fifth pair, and the thirty spinal nerves, give large and conspicuous roots to this system. It exhibits a tissue extending universally.

“It was a still more unfortunate mistake of this ingenious physiologist, to suppose the sympathetic nerve to be the same with that, which in the lower animals (the vermes), is seen coursing from one extremity of the body to the other. In the leech, or worm, those nerves produce union and concatenation of all the voluntary motions, and bestow sensibility as well as motion; yet he saw in the sympathetic system of the human body, only the developement of the same system of nerves, although he was aware that in man the sympathetic nerve bestowed neither sensibility nor the power of motion.

“Bichat announced his system with a popular eloquence, which had a very remarkable influence over all Europe. Physiologists yielding to him, mistook the importance of the several parts of the nervous system; and even the multiplied experiments of Le Gallois failed to convince them of the nature of the spinal marrow.

“The experiments of M. Le Gallois were of the rudest kind possible. The spinal marrow was cut across, or destroyed, by passing skewers into the spinal canal, and the effects were observed; as if the spinal marrow were a simple body. Where-

as, by such destruction of its substance, the original ganglia, which form a series along the spine, must have been hurt; the track of nervous matter which gives rise to the nerves of sensation: that also which gives roots to the nerves of voluntary motion; and the lateral column connected with the offices of respiration, must all have been destroyed by such coarse experiments. It cannot surprise us that the results were obscure and contradictory.

“But the most extravagant departure from all the legitimate modes of reasoning, although still under the colour of anatomical investigation, is the system of Dr. Gall. It is sufficient to say, that without comprehending the grand divisions of the nervous system, without a notion of the distinct properties of the individual nerves, or having made any distinction of the columns of the spinal marrow, without even having ascertained the difference of cerebrum and cerebellum, Gall proceeded to describe the brain as composed of many particular and independent organs, and to assign to each the residence of some special faculty.

“When the popularity of these doctrines is considered, it may easily be conceived how difficult it has been, during their successive importations, to keep my pupils to the examples of our own great countrymen. Surely it is time that the schools of this kingdom should be distinguished from those of France. Let physiologists of that country borrow from us, and follow up our opinions by experiments*, but let us continue to build that structure which has been commenced in the labours of the Monros and Hunters.

“The whole history of medical literature proves, that no solid or permanent advantage is to be gained, either to medical or general science, by physiological experiments unconnected with anatomy. To disregard the anatomy of the nervous system, or to take it in the gross; to make a new science of *life*; and influenced by a false analogy to call it a fluid; to attempt to direct it along a cord or a wire, is to transgress all the rules of philosophical inquiry, and must be attended with the rapid decline of anatomical studies. They will be considered as imposing restraints on genius, or be rejected as useless; and with them pathology, and all that is most necessary to medical science, will fall into disuse.

* “See the experiments of M. Magendie on the distinctions in the roots of the spinal nerves.”

LXXIX. *On some Extraordinary Inconsistencies in the Greenwich Observations for 1821.* By S. LEE, Esq.

To the Editors of the Philosophical Magazine and Journal.

Gentlemen,

IN my letter of the 24th November last, I pointed out some extraordinary inconsistencies in the Greenwich observations for 1821. I now proceed to notice some others of a different description, and which for the reasons already given, I have arranged in three separate additional classes.

Class IV. exhibits a comparative view of the intervals of time between the meridian passages of certain stars, as observed on the same night, with the transit instrument and the mural circle.

Class V. contains the north polar distances of γ *Draconis*, and some other remarkable stars, taken out of the observations with the mural circle, from readings with two and with six microscopes.

Class VI. gives the intervals of time between the passage of some of the principal fixed stars, by the wires of the transit instrument, as observed on different nights.

With respect to the three first classes, little more can be said than that they prove extreme carelessness in the observer, the transcriber, or the computer; for, as I have already stated, they are not the faults of the printer.

The fourth class show that proper care has not been taken to bring the plane of the mural circle truly into the plane of the meridian. It may be alleged, that a small deviation therefrom does not, in most cases, occasion any considerable error in the north polar distances: but it must also be admitted, that such want of adjustment, however insignificant its effect, ought not to be allowed to remain in one of the principal instruments of the Royal Observatory at Greenwich.

It is very remarkable that so few transits should have been taken with the Circle, and that the stars observed should be so ill adapted to the purpose of ascertaining the correctness of its position. Indeed, it is hardly possible to imagine a more injudicious selection.

The observations which form the fifth class were extracted for the purpose of ascertaining the stability of the Circle.

A very slight comparison of these extracts with one another, will convince any one (supposing the observations to have been carefully made and accurately recorded) that the instrument must be extremely unsteady.

Such extravagant variations of north polar distance from

one night to another, frequently in direct opposition to what might have been expected from refraction, aberration, or nutation, and so capricious as to defy even a *southern motion* to explain—ought to have attracted the attention of the observer, and instantly led to a suspicion of something wrong: but full eight months were suffered to elapse before any notice was taken of them. Such a lamentable ignorance of the state of the instrument could never have existed for a single day, had the Circle been provided with a plumb-line or a level, or had the zenith sector been employed in conjunction with it, for ascertaining its line of collimation.

The sixth class consists of observations of the passage of certain remarkable fixed stars, by the wires of the *justly celebrated ten-feet* transit instrument, and are intended to show the degree of confidence due to an observation by any single wire. A comparison of the observations of the same star on different nights, plainly shows that the Greenwich transits are liable to errors which one would hardly expect to find in observations with an instrument of only as many *inches* focal length.

The observations of transits with the mural circle appear to be noted down with a very culpable degree of negligence: as a proof of which, it is only necessary to cite a few examples from the Observations of 1822 just published.—On \llcorner 3d of June, *Castor* passed the meridian instead of *Procyon*. On \sphericalangle 20th of July, *Arcturus* is made to pass the meridian twice in the space of little more than two hours. On \odot 28th of July, α *Ophiuchi* passed the meridian of the Circle-room about $1^{\text{h}} 1^{\text{m}}$ before it passed the meridian of the Transit-room; and \sphericalangle 30th of July, in the Transit-room α *Coronæ* passed the meridian $8^{\text{m}} 21^{\text{s}}$ before α *Serpentis*, but in the Circle-room not till $1^{\text{m}} 38^{\text{s}}$ after that star.

The intervals between the transits of α *Lyræ* and α^2 *Capricorni* in the Circle observations for the same year, frequently differ more than $2''$ from the true interval; which (if these observations are to be relied on) show that in 1822 that instrument was still more out of the meridian than in 1821.

During the whole of the year 1821, only sixteen eclipses of Jupiter's satellites were observed at Greenwich; though no less than eighteen were observed in the last five months alone by Mr. Beaufoy at Bushy. No occultations of the stars by the moon are to be found. The occultation of the Pleiades by the moon on the 13th of October is not noticed, though observed at Bushy; and the weather seems to have been favourable, for the transit of α *Pegasi*, which took place on that night about a quarter of an hour before the occultation, was observed at Greenwich.

The comet also which was observed by Dr. Burney at Gosport, on the evening of the 24th of February, and on several evenings after, appears to have been overlooked.

It seems to be the practice at Greenwich (for six nights in a week at least) to cease observing *from midnight to sun-rise*. For it would be difficult to prove from the observations of 1821, that either the astronomer or any of his assistants quitted their warm beds much more than about 40 nights out of 365, for the purpose of making an observation.

There is no institution in the world so amply endowed in every respect as the Royal Observatory at Greenwich. It was a favourite object with the late king; and the truly royal munificence of its present patron must be acknowledged with gratitude by every sincere friend to astronomy. Provided with no less than four assistants, whose salaries, added to his own, amount to upwards of 1200*l.* a-year,—surely the Astronomer Royal might appropriate a rather larger portion of the night to the cultivation of the science over which he is appointed to preside, with so many advantages and encouragements. Instruments and books have been furnished here in abundance, without the least regard to expense, and every accommodation that private comfort can require, granted without reserve.

I am, gentlemen, yours, &c.

London, Dec. 20, 1824.

STEPHEN LEE.

CLASS IV.

	Merid. Pass. by Transit.			By Circle.		
	H.	M.	S.	H.	M.	S.
♂ Feb. 6, Aldebaran	4	25	20.84	4	25	6.00
Capella	5	3	10.74	5	2	54.50
Intervals	0	37	49.90	0	37	48.50
♂ Feb. 6, Capella	5	3	10.74	5	2	54.50
♀ ——— 7, ———	5	3	10.20	5	2	54.00

Therefore the rates of the two clocks were so nearly alike that no allowance need be made on that account. But the interval between the passage of *Aldebaran* and *Capella* is 1^h.4 of time greater by the transit than by the circle.

	H. M. S.			H. M. S.		
	H.	M.	S.	H.	M.	S.
♀ Sept. 7, α Lyræ	18	30	40.68	18	30	22.00
α Aquilæ	19	41	51.72	19	41	34.50
Intervals	1	11	11.04	1	11	12.50
♂ Sept. 6, α Aquilæ	19	41	52.30	19	41	34.50
♀ ——— 7, ———	19	41	51.72	19	41	34.50

Therefore

Therefore allowing 0^s.03 for the different rates of the clocks, the interval between the passage of α *Lyræ* and α *Aquilæ* is 1^s.43 of time less by the transit than by the circle.

CLASS V.

1. N.P.D. of Polaris above the Pole.

		With 2 Microscopes.	With 6 Microscopes.
♀ July	27,	1° 39' 21".0 - 8".1	1° 39' 20".6 - 7".8
♀ August	3,	1 39 12.9 + 2.7	1 39 12.8 + 1.0
♂ ———	4,	1 39 15.6 + 2.7	1 39 13.8 + 1.0

2. N.P.D. of Polaris below the Pole.

♂ July	31,	358° 21' 49".9 - 5".7	358° 21' 49".2 - 4".8
♂ August	4,	358 21 44.2 - 5".7	358 21 44.4 - 4".8

3. N.P.D. of Capella.

♂ July	28,	44° 11' 30".5 - 5".6	44° 11' 28".4 - 5".5
♀ August	3,	44 11 24.9 - 5".6	44 11 22.9 - 5".5

4. N.P.D. of β Tauri.

♁ January	29,	61° 32' 33".1 + 0".8	61° 32' 31".7 0".0
♁ ———	31,	61 32 33.9 + 0".8	61 32 31.7 0".0

5. N.P.D. γ Draconis.

♀ January	19,	38° 29' 22".5	38° 29' 21".7	-0' 56".5
⊙ ———	28,	38 29 26.1 + 0' 3".6	38 28 25.2 + 0 0 2	0 0 2
♀ February	2,	38 28 25.9 - 1 0 2	38 28 25.4 + 0 0 2	0 0 2
⊙ ———	4,	38 28 28.9 + 0 3 0	38 28 27.7 + 0 2 3	0 2 3
♂ July	28,	38 29 0.9 - 0 13.4	38 28 58.6 - 0 11.1	0 11.1
♀ August	1,	38 28 47.5 + 0 6 9	38 28 47.5 + 0 5 4	0 5 4
♀ ———	3,	38 28 54.4 + 0 0 3	38 28 52.9 + 0 1 5	0 1 5
♂ ———	4,	38 28 54.7 + 0 0 3	38 28 54.4 - 0 1 7	0 1 7
⊙ ———	5,	38 28 55.0 + 0 0 3	38 28 52.7 - 0 1 7	0 1 7

6. N.P.D. α Lyræ.

♂ July	28,	51° 22' 15".4 - 6".9	51° 22' 14".6 - 7".7
♀ August	3,	51 22 8.5 - 6".9	51 22 6.9 - 7".7

7. N.P.D. α Cygni.

⊙ January	28,	45° 21' 8".3 + 6".7	45° 21' 10".5 + 4".3
♀ ———	31,	45 21 15.0 + 6".7	45 21 14.8 + 4".3

CLASS VI.

Passage by the Wires of the Transit Instrument.

1. Aldebaran.

♁	February 6,	^{s.} 42.5	^{s.} 2.0	^{s.} 20.9	^{s.} 39.8	^{s.} 59.0
		19.5	18.9	18.9	19.2	
♃	——— 8,	41.8	0.4	19.7	39.2	58.2
		18.6	19.3	19.5	19.0	

2. Capella.

♁	February 5,	18.5	44.5	10.9	37.2	3.5
		26.0	26.4	26.3	26.3	
♃	——— 7,	17.5	43.6	10.4	41.5	3.0
		26.1	26.8	31.1	21.5	
♁	——— 13,	14.6	41.4	7.6	33.6	0.0
		26.8	26.2	26.0	26.4	

3. Sirius.

♃	February 8,	18.2	37.3	56.5	15.5	14.5
		19.1	19.2	19.0	59.0	
♁	——— 19,	14.6	34.1	53.2	12.3	31.2
		19.5	19.1	19.1	18.9	

4. Castor.

♃	March 14,	51.1	12.5	34.5	55.7	17.5
		21.4	22.0	21.2	21.8	
♁	April 8,	55.5	17.8	39.0	0.6	22.1
		22.3	21.2	21.6	21.5	

5. Procyon.

♃	February 15,	57.7	16.0	34.3	52.6	10.3
		18.3	18.3	18.3	17.7	
♁	——— 19,	56.6	15.2	33.5	51.8	10.4
		18.6	18.3	18.3	18.6	
♃	March 16,	41.3	0.3	18.3	37.2	55.4
		19.0	18.0	18.9	18.2	
♃	——— 30,	29.0	48.6	8.5	27.3	45.7
		19.6	19.9	18.8	18.4	

6. α Aquarii.

♃	October 31,	59.2	17.8	36.3	59.6	13.2
		18.6	18.5	23.3	13.6	
♁	November 6,	58.5	16.5	35.2	53.5	11.9
		18.0	18.7	18.3	18.4	
♃	——— 23,	54.2	12.8	30.9	49.3	7.7
		18.6	18.1	18.4	18.4	

LXXX. *Upon the System of Vegetable Physiology of M. AUBERT DU PETIT THOUARS: in Reply to Sir JAS. EDW. SMITH. By J. LINDLEY, Esq. F.L.S. &c. &c.*

To the Editors of the Philosophical Magazine and Journal.
Gentlemen,

WHEN I communicated to you in August last, an abstract of the opinions upon Vegetable Physiology of M. du Petit Thouars, I at the same time expressed a hope that that remarkable theory would attract attention in this country. Little, however, did I anticipate the honour of a reply from the distinguished President of the Linnean Society, and still less did I suspect that my plain and inoffensive statement would have caused uneasiness where I should most have desired approbation.

Much as is due to courtesy, to personal respect, to rank, and to scientific reputation, yet I feel that more is due to the interests of science, and that those interests would be compromised by a silent acquiescence on my part, in the accuracy of the statements of your learned correspondent.

To his first statement, that no comparison has been made by me between the opinions of M. du Petit Thouars and those of other eminent botanists, I beg to answer; that I did not propose to institute a comparison between certain systems of vegetable physiology, but that I avowedly confined myself to the simple statement of particular opinions of an original character, without reference to any other opinions whatsoever; that if I had attempted to compare one theory with another theory, or one discovery with another discovery, I should have necessarily been obliged to consider such opinions only as are original; and that, therefore, an examination of those contained in Sir James Smith's excellent *Introduction to Botany* would have been rendered superfluous, by a previous consideration of the works of the writers from whom they have been judiciously adopted.

The intimation that M. du Petit Thouars' opinions are not peculiar to himself, can have arisen only from the circumstance that the President of the Linnean Society has not ever seen any of the works of one of the most acute physiologists of our time. The unvarying candour of Sir James Smith having induced him to make this avowal, I can only lament that he should have been prevented by such a cause from acquiring that degree of information upon the subject of my letter which was indispensable to him before forming an opinion upon it. In this place, and within the limits necessarily prescribed to communications of the present

sent nature, it would be impossible to enter into a minute discussion of the accuracy of Sir James Smith's statement,—that his published opinions, and those of M. du Petit Thouars are the same. Fortunately, however, such a measure is unnecessary; for I have reason to think that when Sir James Smith is informed that all the Linnean botanists, and many even of those who profess other things in France, the Thouins, Lefebures, Feburiers, Bernéauds, and other equally celebrated men, are violently opposed to M. du Petit Thouars, he will consider whether he may not have been too hasty in identifying himself with the heterodox opinions of my friend.

To the latter part of Sir James Smith's letter I do not feel it necessary to reply. The complaint that I had overlooked in the preface to my little translation of the late M. Richard's admirable treatise upon fruits and seeds, all that the Linnean school of botany had been doing for thirty years before, must have arisen out of a misconception of my meaning, or from some ambiguity of expression on my part. I said that with reference to the subject of the work in question, that is, of fruits and seeds, nothing had been done in the form of an elementary work. For the truth of such a statement, I appeal to the world.

I am, gentlemen, your obedient servant,

Turnham Green, Nov. 4, 1824.

JOHN LINDLEY.

LXXXI. *Notices respecting New Books.*

Recently published.

THE Geological Society has just published a Half-volume of Transactions, being Part II. of Volume I. of the Second Series. It contains the following papers:

Notes on the Geography and Geology of Lake Huron; by John J. Bigsby, M.D.—Observations on the South-western Coal District of England; by the Rev. W. Buckland, and the Rev. W. D. Conybeare.—Geological Observations on Part of Gloucestershire and Somersetshire; by Thomas Weaver, Esq.—Extracts from a paper entitled, “Remarks on the Strata at Stinchcombe near Dursley, in Gloucestershire;” by George Cumberland, Esq.—On the Crag Strata at Bramerton, near Norwich; by Richard Taylor, Esq. of Norwich.—On the Alluvial Strata and on the Chalk of Norfolk and Suffolk, and on the Fossils by which they are accompanied; by Richard Taylor, Esq. of Norwich.—On the Strata observed in boring at Mildenhall, Suffolk: extracted from a letter addressed to

Vol. 64. No. 320. Dec. 1824.

3 M

W. Somer-

W. Somerville, M.D.; by Sir Henry Bunbury, Bart.—On the Discovery of an almost perfect Skeleton of the Plesiosaurus; by the Rev. W. D. Conybeare.—Notice on the Megalosaurus or great Fossil Lizard of Stonesfield; by the Rev. W. Buckland.—On the Geology and Topography of the Island of Sumatra, and some of the adjacent Islands; by the late William Jack, M.D.—Geological Observations made on a Voyage from Bengal to Siam and Cochin China; by J. Crawford, Esq.—Notes made in the Course of a Voyage from Bombay to Bushire in the Persian Gulf; by J. B. Fraser, Esq.—An Account of some Effects of the late Earthquakes in Chili: extracted from a letter to Henry Warburton, Esq.; by Mrs. Maria Graham.—Account of some Terraces, or ancient Beaches, in the Isle of Jura; by Capt. Vetch, R. E.—With various other papers and notices; the whole illustrated by 25 Plates, Maps and Sections, many of them coloured.

The Second Part of the First Volume of The Memoirs of the Astronomical Society has just been published, and the following are its contents:

Observations on the Collimation Adjustment of a Transit Instrument; together with some Arguments in favour of certain Circumpolar Stars being added to our standard Catalogue, to facilitate a rigorous and frequent Examination of the Position of the Instrument with regard to the Meridian, and of the Altitude of the Pole, relative to the Observer's Station. By James South, Esq.—Tables of the Semidiameter of the Moon in Time, &c. By William Lambert, Esq.—Observations of the Planets during the Period of their respective Oppositions in 1820, 1821, and 1822; with the Computation of their Geocentric Longitudes and Latitudes, by means of the assumed Parallax therein mentioned, and of his own Tables of Refraction. By S. Groombridge, Esq.—On the Triangulation of the Cape of Good Hope. By Captain G. Everest.—The Right Ascension and Declination of the Comet of January 1821. By J. N. Nicollet.—On the Correction of the Transit Instrument. By J. J. Littrow.—On the Aberration of Light. By Benjamin Gompertz, Esq.—On the Measurement of Altitudes by the Barometer. By Professor Littrow.—A Note respecting the Application of Machinery to the Calculation of Astronomical Tables. By Charles Babbage, Esq.—Observations on the Application of Machinery to the Computation of Mathematical Tables. By Charles Babbage, Esq.—On some new Tables for determining the Time, by means of Altitudes taken near the Prime Vertical. By Francis Baily, Esq.—On a new Method of computing Occultations of the

the Fixed Stars. By J. F. W. Herschel, Esq.—The Results of Computations relative to the Parallax of α Lyræ, from Observations made with the Greenwich Mural Circle. By the Rev. Dr. Brinkley.—On the Differences of Declination of certain Stars, according to different Astronomers; and on Refraction, &c. Extracted from a Letter of M. J. J. Littrow.—On the Theory of Astronomical Instruments. By Benjamin Gompertz, Esq.—On the Theory of Astronomical Instruments. By Benjamin Gompertz, Esq.—A Supplement to the Theory of Astronomical Instruments; being the Equation of the Reflecting Instrument. By Benjamin Gompertz, Esq.—On the Mercurial Compensation Pendulum. By Francis Baily, Esq.—Subsidiary Tables for facilitating the Computation of Annual Tables of the apparent places of Forty-six principal Fixed Stars, computed by order of the Council of this Society: to which is prefixed a Statement of the Formulæ employed, and Elements adopted in their Construction. Drawn up by J. F. W. Herschel, Esq.—Reports of the Council to the Third and Fourth Annual Meetings.—Prize Questions; Addresses of the President; List of Presents, &c. &c.

LXXXII. *Proceedings of Learned Societies.*

ROYAL SOCIETY.

THE Anniversary Meeting of this Society was held as usual on St. Andrew's Day, November 30, 1824.

The illustrious President, after announcing the additions made to the number of members of the Society in the last year, and stating the deaths that had taken place, referred to the Baron Maseres, as the only scientific author and contributor to the Transactions whose loss he had to announce: he paid a handsome tribute of respect to the deep mathematical knowledge and disinterested love and patronage of science of this learned Judge; who published many important algebraic works at his own expense, and enabled other persons to bring forward publications which without his protection would never have seen the light. He then proceeded to announce the award of the medal on Sir Godfrey Copley's donation; which the Council has bestowed on the Rev. Dr. Brinkley, President of the Royal Irish Academy, for his various communications to the Royal Society.

“Some persons who have not closely followed the usages of the Council may be surprised,” said the learned President, “that in two successive years this token of the respect of the Society should have been given for labours in the same sci-

ence, particularly when no great discoveries have resulted from them: but where a prize is to be given annually, which is one of the conditions of the donation, it cannot always be bestowed for grand and brilliant results; and no branch of human knowledge more demands encouragement than astronomy: for, having arrived almost at a mature state, it offers, perhaps, fewer objects of new inquiry than any other science, and improvements can be made in it only by the greatest delicacy of observation, by great labour, and that at a time which is usually devoted to repose, and often with a sacrifice of health. The astronomer requires not days or nights only, but months or years for his results, and demands all the sympathy and all the attentions and kind feelings of his brethren in science."

The learned President paid some high compliments to Dr. Brinkley, dwelt upon his profound mathematical knowledge, the most essential quality of an accomplished astronomer; upon his accuracy, acuteness, and minute spirit of observation; and upon the strength of his reasonings, and the candour and justice of his philosophical views. "You know, gentlemen," he said, "that Dr. Brinkley and the Astronomer-royal are at issue upon two great points of astronomy;—one affirming, the other denying, a sensible parallax of some of the fixed stars. One denying, the other affirming, a southern motion of a considerable part of the sidereal system. The Council of the Royal Society," observed the President, "did not, by their vote of the medal to Mr. Pond last year, mean to decide on the evidence on these subjects, or to give an opinion on these obscure and difficult questions in astronomy, depending upon such nice observations. They make the same reservation this year; founding their award upon the great and general scientific merits of Dr. Brinkley, and on the approximations that he has made to the solutions of these problems. The learned President gave a history of the progress of sidereal astronomy, and particularly of the inquiries made respecting parallax, or the differences of the angles made by fixed stars with the two extremities of the earth's orbit.—He detailed the opinions or observations and experiments of Galileo, Flamsteed, Hooke, Bradley, Mitchell, Herschel, Cassini, La Caille, and Piazzi. He stated that Dr. Brinkley's latest and most refined result on the parallax of α *Lyrae* (the star in which he has most invariably observed the phenomenon) of one second and a few hundredth parts, is not opposed to Dr. Bradley's view of the subject, or to the photometrical considerations of Mr. Mitchell and Mr. Gauss. He stated that with respect to the southern motion, Dr.

Brinkley's

Brinkley's opinion was supported by that of other astronomers. "These questions," added the illustrious President, "are not matters of useless controversy, nor even of mere curiosity; all the laws, all the phænomena of astronomy, are more or less connected with them. The fixed stars are in the system of the heavens, what land-marks or the extremities of base lines are to measures upon the earth; and the correctness and use of our calculations depend upon the supposition of the permanency of their arrangements."

"In waiting," he continued, "for new elucidations on this subject, he could not but congratulate the Society on the existing state of astronomy and the number of its cultivators, which rendered it impossible that any great problem could long remain unsolved. "Whilst such philosophers exist," he said, "as Dr. Brinkley at Dublin; M. Bessel at Königsberg; Dr. Schumacher at Altona; Arago at Paris; Olbers at Bremen; and Gauss and Hardinge at Göttingen; the science cannot but be progressive, its results cannot but become more perfect and more refined. The improving state of astronomy abroad, and the increased perfection of instruments, ought," said the learned President, "to be subjects of congratulation to us, not of jealousy or uneasiness—for the language of science is universal: she is of no country; her results are for the whole human race; and belong not merely to the present generation, but to posterity. And Astronomy above all branches of human knowledge demands for its advancement the co-operation of philosophers in the most remote parts of the globe."—Amongst other instances of this truth, he gave the fact, that the return of the Comet within a period of four years, calculated by Encke, would not have been verified, but for the observatory established by the liberality of Sir Thomas Brisbane in New South Wales.

After comparing the astronomy of ancient and modern nations, and pointing out the improved state of this science as one of the great characteristics of the present times, he concluded by some observations upon its utility, and its effects in enlightening and exalting the human mind.

"By means of this science," added the learned President, "the trackless ocean is safely navigated, and in unknown seas the distance of the vessel from known land discovered: all vague and superstitious notions respecting the heavenly bodies, which in ancient times had such an effect upon the destinies of nations and individuals, have vanished. Man, acquainted with his real situation in the scale of the universe, has learned likewise to appreciate more distinctly, his objects, and the end of his creation,—a mere atom fixed upon a small
point

point of space, and limited as it were to moments of time,—yet by his intellectual powers he has elevated his mind from the minute base of the earth unto the heavens, and measured and even weighed bodies at many millions of miles distant from him, and some of them invisible except by instruments of his own invention:—he has been enabled to predict their past and future changes, and to account for those motions of them, which at first view appeared disorderly, by constant and immutable laws: and as his science has become more perfect, so he has seen more distinctly the order and harmony of the system of things, and the whole of created nature, exhibiting one design of perfect wisdom, a single work of infinite power.” This is a short sketch only of the speech:—after which the Society proceeded to the election of Officers, when, on the ballot being closed, it was found that the following were the lists:

Of the Old Council.—Sir Humphry Davy, Bart.; William Thomas Brande, Esq.; Samuel Goodenough, Lord Bishop of Carlisle; Major Thomas Colby; John Wilson Croker, Esq.; Davies Gilbert, Esq.; Charles Hatchett, Esq.; Sir Everard Home, Bart.; John Pond, Esq.; William Hyde Wollaston, M.D.; Thomas Young, M.D.

Of the New Council.—William Babington, M.D.; Francis Baily, Esq.; John George Children, Esq.; John William, Viscount Dudley and Ward; John Frederick William Herschel, Esq.; Captain Henry Kater; Thomas Andrew Knight, Esq.; Alexander MacLeay, Esq.; Sir T. S. Raffles, Knt.; Edward Adolphus, Duke of Somerset.

President.—Sir H. Davy.

Treasurer.—Davies Gilbert, Esq.

Secretaries.—W. T. Brande, Esq. and J. F. W. Herschel, Esq.

Foreign Secretary.—T. Young, M.D.

The Society dined together at the Crown and Anchor; The President in the chair, supported by the Right Hon. Robert Peel, and Lord Bexley. There were present most of the distinguished cultivators and lovers of science. Several speeches were made, showing the flourishing state of science and of the Society, and the harmony existing between the patrons and votaries of science.

Dec. 9.—Three Series of Astronomical Observations made at Paramatta, were communicated by Sir Thomas Brisbane; and the reading was commenced of An Explanation of an optical deception produced by viewing the spokes of a revolving wheel through the intervals of vertical bars. By P. M. Roget, M.D. F.R.S.

Dec. 16.—The reading of Dr. Roget's paper was concluded;

cluded; and a paper was read, communicated by the President, On a new Photometer, by A. Ritchie, A.M.

Dec. 23.—Two papers by the Rev. B. Powell, F.R.S. were read, supplementary to a former paper, relating to the Solar Light and Heat:—when the Society adjourned to January 13.

LINNÆAN SOCIETY.

Dec. 7.—W. G. Maton, M.D., Vice-president, in the chair.

Mr. Sowerby exhibited some specimens of Beryl from the Mountains of Morne in the county of Down. The reading of the Third Part of Dr. Hamilton's Commentary on the *Hortus Malabaricus* was continued. Among the plants which were the subject of investigation were the following: *Codda Panna*, *Niti Panna*, *Todda Panna*, *Katou Indel*, *Tsjaka Maram*, *Ata Maram*, *Anona Maram*, *Ansjeli*, *Kato Tsjaka*, &c.

Dec. 21.—A letter from Mr. Youell was read, stating that *Ardea cayanensis* had been taken near Yarmouth: also a fine specimen of the Green Ibis of Latham, and which had been deposited in the Norwich Museum. Mr. Y. also corrects some erroneous statements of Mr. Bewick respecting the *Fulica atra*.

Read also an account, by the Rev. W. Kirby, of a remarkable Fungus, which he names *Atractus*, and places between *Clathrus* and *Phallus*: and a Description of such Genera and Species of Insects, alluded to in the "Introduction to Entomology" of Kirby and Spence, as appear not to have been before sufficiently noticed and described: by the Rev. W. Kirby.

GEOLOGICAL SOCIETY.

Dec. 3.—A notice was read, "On some Fossils found in the Island of Madeira;" by the late T. E. Bowdich, Esq.

In this notice, the author describes a formation of branched cylindrical tubes incased with agglutinated sand, which occur in great abundance near Fanical, 15 miles from Funchal, in the Island of Madeira. Mr. Bowdich is inclined to refer these to a vegetable origin. They are accompanied by shells, some decidedly terrestrial, and others which appear to belong to a marine genus. In conclusion, some account is given of the general features and structure of the neighbouring district.

An extract of a paper was then read, entitled "An Inquiry into the Chemical Composition of those Minerals which belong to the genus Tourmaline;" by Dr. C. G. Gmelin, Professor of Chemistry in the University of Tubingen, and For. Mem. G.S.

Professor Gmelin, in this memoir, details at length, the various

various analyses of minerals of the Tourmaline family which have been made by former chemists. He then describes the methods which he adopted in his own experiments, and adds the results which he obtained from them.

The author divides the different species of Tourmaline into the following sections: 1st, Tourmalines which contain lithion; 2d, Tourmalines which contain potash or soda, or both these alkalies together without lithion and without a considerable quantity of magnesia; 3rd, Tourmalines which contain a considerable quantity of magnesia, together with some potash, or potash and soda.

“It appears,” he says, in conclusion, “that when we compare the analyses of the different species of Tourmalines, the most essential ingredients are boracic acid, silica, and alumine, whose relative quantities do not vary much. It appears further, that any alkaline substance, though in no considerable quantity, may be likewise an essential ingredient. The different nature of these alkaline substances may be employed by the chemist, as we have used it, to divide these minerals into different sections. But it will appear to be quite useless to attempt to give mineralogical formulæ for the chemical composition of these minerals, when it is considered; 1st, that we can by no means rely upon the correctness of any statement regarding the quantity of oxygen in boracic acid; 2dly, that the quantity of alkaline bases, whose oxygen would be unity, is so small, that it cannot be determined (with sufficient accuracy) without great errors in the computation of the relative quantity of oxygen in the other ingredients; 3dly, that in one species no account could be given of a considerable loss of weight. He has, however, calculated the quantities of oxygen in every species, with the intention of comparing the sum of the oxygen contained in the bases, with the sum of that contained in the acids, viz. boracic acid and silica. The result of this calculation is then fully stated.

ASTRONOMICAL SOCIETY.

Dec. 10.—At the meeting this evening, the publication of the Second Part of the First Volume of the Memoirs of the Society was announced, the contents of which will be found in our “Notices respecting new Books.”

A paper, drawn up by Dr. Gregory, was read, containing a Description of a Box of Rods, named the *Rhabdological Abacus*, presented to the Society by the family of the late Henry Goodwyn, Esq., of Blackheath. It appears that these rods were invented by Mr. Goodwyn, for the purpose of facilitating the multiplication of long numbers of frequent occurrence;

currence; they were probably suggested by Napier's Rods, and are, for the purposes which the inventor had in view, a great improvement upon them. The rods, which are square prisms, contain on each side successively the proposed number in a multiplicand, and its several multiples up to 9 times; and these in the several series of rods are repeated sufficiently often to serve for as extensive multiplications as are ever likely to occur. Thus, if the four faces of one rod contain respectively, once, twice, three times, and four times a proposed multiplicand; another rod will exhibit in like manner 2, 3, 4, and 5 times the same; a third rod 3, 4, 5, and 6 times the same; and so on, to *nine*, and in several cases, more rods.

The numbers are arranged uniformly upon equal and equidistant compartments, while, at a small constant distance to the left of each product, stands the number 2, 3, 4, 5, &c. which it represents. Hence, in performing a multiplication, the operator has only to select from the several faces of the rods the distinct products which belong to the respective digits in the multiplier, to place them in due order *above* each other, to add them up while they so stand, and write down their sum, which is evidently the entire product required, and obtained without the labour of multiplying for each separate product, or even of writing those products down. For still greater convenience, the rods may be arranged upon a board with two parallel projections placed *aslant* at such an angle as of necessity produces the right arrangement. There are blank rods to place in those lines which accord with a cypher in the multiplier; and the arrangement may easily be carried on from the bottom product upwards, by means of the indicating digits.

A letter was read from Captain Ross, a member of this Society, giving an account of observations made on the Occultation of Jupiter by the Moon on the 5th of April last; transmitting also an account of observations upon the same occultation, by Mr. Ramage, of Aberdeen, with one of his own 25-feet reflecting telescopes.

Mr. Ramage observed the *immersion*. On the approach of Jupiter's satellites to the moon no diminution of their light was perceptible. On coming into contact with the moon's dark limb, they did not disappear instantly, like fixed stars, but formed an indentation or notch in the limb, as if they were imbedded in it, but were at the same time separated from it by a fine line of light. This indentation continued visible until about *half* their diameters were immersed, when it disappeared. All the satellites presented this phenomenon; but

the 4th and 3rd with the greatest distinctness. On Jupiter's approach, no difference of his light or shape was perceptible; but after the contact had taken place, he appeared to exhibit no deficiency of disc, but presented a complete figure, as if placed between the moon and the earth; this appearance continuing for a few seconds. When the planet was almost entirely immersed, his retiring limb appeared as though it were considerably elongated, or formed a segment of a much larger circle than had been previously presented. The position of Mr. Ramage's telescope did not allow him to observe the emersion.

Captain Ross was prevented by the state of the weather from seeing the *immersion*, but was fortunate enough to observe the *emersion*, seeing first, a considerable *elongation*, which gradually diminished as more of the planet appeared from behind the moon.

Part of a letter was read from Mr. R. Comfield, a member of this Society, in reference to the same occultation. He observed it at Northampton with a good Newtonian reflector. Mr. Comfield and two other contemporaneous observers, with good instruments, noticed, that when Jupiter had about half disappeared, there was exhibited an adhesion or protuberance on each side of the planet, which as Jupiter sunk behind the moon, became larger and larger, so that just before the entire disappearance of the planet it exhibited a considerable elongation deviating greatly from a circular curve of the same diameter as the planet.

Phænomena somewhat analogous, especially in reference to the indentations and adhesions, were noticed by several astronomers, who observed the transit of Venus in 1769.—See the accounts by Captain Cook, Mr. Charles Green, Mr. Charles Mason, M. Pingré, &c. in the Philosophical Transactions for 1770 and 1771, which are here adverted to, because the consideration of kindred phænomena may assist in the explication of the whole.

ROYAL ACADEMY OF SCIENCES OF PARIS.

July 19.—The Academy continued the examination of the questions addressed to it by the Government, relative to the precautions required in the use of steam-engines. M. Chevreul read a Memoir on different species of bile, and in particular on the presence of cholesterine in human bile and in that of the bear.

July 26.—M. Roques proposed to found a prize for the discovery

covery of a method of rendering the cornea transparent.—M. le Baron Blein communicated a new Memoir on Colours.—M. Gay-Lussac gave an account of an experiment relative to Mad. Gervais's apparatus, which proved that a very small quantity only of volatilized wine could be collected by its means.—M. Latreille read a note on a new genus of Spider, which he has named *Myrmecia*.—M. Yvart made a verbal report on the Agricultural Annals of Roville, published by M. Dombasles. A report was received from M. Bosc, on a species of Leech found at Martinique; and another from M. Cauchy, on the mathematical researches of Professor Simonoff of Casan.

LXXXIII. *Intelligence and Miscellaneous Articles.*

ACCOUNT OF AN EXAMINATION OF FUSED CHARCOAL.
BY LARDNER VANUXEM.

THE specimen examined was sent to Dr. Cooper by Professor Macneven of New York, who obtained it by means of the deflagrator invented by Dr. Hare.

Dr. Cooper was so good as to present me with the fused charcoal, knowing that I was extremely desirous of experimenting upon it, being very sceptical as to its resulting from the fusion of the carbonaceous part of the charcoal, believing on the contrary that it was little else than the metallic, earthy, saline, or alkaline materials, probably enveloping charcoal in the black globules, or if iron were present, combined with that metal, constituting a product analogous to steel.

My opinion that the fused charcoal in question was derived from the impurities of the charcoal, was principally owing to the sources of error not having been removed; and that these sources are very considerable, is well known, not only to those who have been engaged in the analyses of the different kinds of our ordinary combustible substances, but is obvious to the common observer, by the quantity of ashes which is left, when wood or coal has been incinerated.

Dr. Macneven did not mention that he made any experiment upon the fused charcoal, other than that of ascertaining its comparative density with sulphuric acid, in which liquor it sunk.

The fused charcoal consisted of one large, and one small globule, connected together by a thread, or thin bar of the same material, and resembled a double-headed shot; externally its colour was black and without lustre, and was perfectly opaque. It weighed 2.5 centigrammes, or 0.385 of a grain.

In the first experiment it was heated red hot by a blowpipe in a silver spoon with caustic potash, which had no action upon it; for when well washed and dried, the weight remained the same.

It was then put into an agate mortar, pressed, and struck with considerable force: finding it yielded without breaking, and observing that it received a polish, it was examined, and found to resemble iron. To confirm the analogy, it was next tried with a file, which acted upon it as it would on soft steel or iron; after this it was subjected to a magnet, to which it readily attached itself; and lastly, with a hammer: by its great malleability conjoined with the characters just mentioned, it proved its identity with iron.

The fused charcoal was next subjected to the action of nitric acid in a small platina capsule, there was no effect till the acid was heated, it then attacked the mass, very violently disengaging nitrous fumes, and separated it into several pieces; although fresh additions of nitric acid were made, yet the whole did not dissolve. The unattacked part was separated from the liquor, and examined with a microscope; it still exhibited the same appearance, and still was magnetic. However, by a further division of the substance, it was all dissolved by nitric acid, except one small piece reserved for exhibition.

The nitric liquor was evaporated to dryness; muriatic acid and water were then added to dissolve the iron, which took up the whole of it, leaving a small quantity of whitish matter, from which the liquor was separated by decantation; this matter resembled silix; the quantity, however, was too small to ascertain correctly its nature, for it weighed no more than 0·0025 gramme.

Ammonia added to the liquor, gave the reddish brown precipitate of hydrate of per-oxide of iron; separated from the liquor, dried and calcined, it weighed 0·0175, equal to 0·012 gramme of metallic iron.

Hence we have for result—

Iron	0·0120
Silix	0·0025
Loss	0·0105

Gm. 0·0250

From the results obtained, it is very evident that this product of the fusion of charcoal must consist merely of the impurities contained in the charcoal, and is not a *fusion of its carbon*, as has been supposed: moreover, it must consist chiefly of iron; for its lustre, its being acted upon by a file in the manner aforementioned, its great malleability, &c. &c., preclude all idea of any considerable intermixture of other substances with

with it. The great loss in the analysis is due to the violent action of the nitric acid upon it (the capsule being small), also to the filing of the same, and to the great difficulty of correctly operating upon so small a quantity of matter.—*Journal of the Philadelphia Academy of Natural Sciences.*

EXISTENCE OF THE CHALK FORMATION IN NORTH AMERICA?

Geologists have hitherto believed that the Chalk Formation is entirely wanting in America: Thus, Messrs. Conybeare and Phillips, in their *Outlines of the Geology of England and Wales*, observe (p. 67): "Chalk has not been found in any part either of North or South America yet explored, and Mr. Maclure positively asserts that it does not exist on that continent." Dr. Bigsby, however, in his notes on the geography and geology of Lake Huron, printed in the newly published Part of the *Geological Transactions*, states (p. 191), whilst describing the secondary rocks of that district, which are a portion of an immense basin that extends from the southern shore of Lake Winipeg, through Lake Superior, &c., to the Gulf of Mexico, that "Dr. Wright, Inspector of Hospitals, has a specimen of chalk from the neighbourhood of Lake Superior." This statement appears to demand an examination of the locality, in order that so important a circumstance may not rest for proof merely on the characters of a specimen. The subject is one of much interest in geology, and worthy of immediate attention. We would suggest the determination of the point to the American Geological Society.

THE TRUMPETER-BIRD, A TRUE VENTRILOQUIST.

Dr. Traill informs us, that one of his friends in Liverpool has a living specimen of the *Psophia crepitans*, the Trumpeter of English ornithologists. It is, he says, a very social bird, following every individual of the family, and allowing itself to be caressed. The noise it makes has been supposed by some naturalists to have proceeded from the *anus*: but Dr. Traill has ascertained that the bird is a genuine *ventriloquist*, of the most perfect sort. In this specimen, too, the bill is remarkable, by having the lower mandible about one quarter of an inch longer than the upper. This seems to be the usual form of the bill, but may easily be lost in dead specimens, or in stuffed skins.—Some of the frog tribe are also remarkable for their ventriloquial powers.—*Edin. Phil. Journ.* vol. xi. p. 417.

GRANITE COLUMNS.

The first of the immense columns designed by Mr. Smirke for the interior of the King's Library, was delivered at the
new

new building on Friday, the 19th of November: they are of the red Peterhead granite, and the shafts twenty-one feet six inches long, in one piece. It is intended to have them highly polished; and as they are the produce of our own country, and superior to any brought from Egypt and deposited at the Museum, they are interesting in a national point of view.

Calendar of Flora, Fauna, and Pomona, at Hartfield in Sussex, continued from November 22 to December 17.

Nov. 22. St. Cecilia.—Prodigious quantity of rain, the marshes still flooded. Bulfinches already numerous.

Nov. 25. St. Catherine.—Fair day. *Tussilago fragrans* begins to blow. *Viburnum Tinus* in flower.

Nov. 26.—White frost. I observed today a number of Linnets devouring the seeds on the old standing dry stalks of *Oenothera biennis* in the garden. The *Anemone hortensis* is in flower today—a circumstance that not unfrequently occurs in the winter months. There are also flowers left here and there on Marygolds, Leopard's-bane, and other plants.

Nov. 27.—The Rooks and Daws very clamorous as they pass over to and from their pastures in the morning and evening. Wet weather.

Nov. 29.—A change in the weather this evening, which was indicated by head-aches. The wind fell, and the sky became very clear, so that I had an excellent opportunity of observing both Saturn and Jupiter soon after their rising*. Some Polyanthuses and Primroses in blow.

Nov. 30.—Hard rain the whole day.

Dec. 1.—The marshes and low meadows flooded. Wild-fowl seen in the water.

Dec. 2.—A clear morning and stormy afternoon again followed by a night of heavy and continual rain, which produced a great flood in the meadows of the Medway.

Dec. 6.—Fair day: from the motion, however, of a paper kite flying in the air I predicted rain, which fell in torrents at 10 P. M.† Polyanthuses blow here and there.

Dec. 12.—Weather at length fine, open, and mild: the Halcyon

* I noticed again tonight the phænomenon of brilliant colours produced by looking at the stars with a vibrating telescope. Aldebaran showed the most glowing red in great abundance. Capella red, blue, yellow, and black interstitial spaces. I cannot account for the fact that the planets never produce this phænomenon. It looks as if there were some great difference between borrowed and original light. See the *Phil. Mag.* for last March.

† *Prognostication of the change of wind.*—Having frequently amused myself on fine Sunday evenings in summer with a very large paper kite, in order to watch the different currents of wind in the air, I had occasion

cyon days seem really to have set in this year, and to have begun on the very day stated in the Roman Calendar as *Dies Alcyonii* *, for last night the change of weather took place.

Dec. 16.—The Halcyon days continue to afford pleasant weather for winter, the air being calm and mild. The Sweet Coltsfoot is in full flower all over the garden; for I find that this species increases with me so as to become a terrible weed, whereas the White Coltsfoot seldom becomes troublesome by its increase. The Laurestine *Viburnum Tinus* in flower.

Dec. 17.—Mr. B. M. Forster discovered *Agaricus violaceus* in the garden today, which is unusually late in the year. This is the species called Blewits or Waterflaps. The specimen found today was of an unusually pale colour, and rather buff than violaceous.

METEOROLOGY.

To the Editors of the Philosophical Magazine and Journal.
Gentlemen,

In order to reply to Dr. Burney's letter in your last Number, I have looked over my Journal, and find the observation on the barometer on the morning of the 12th of October, is put down 29·75; and although I have for eight years been in the constant habit of noting down the indications of the several instruments, I will not be positive that it is in this instance correct, on the contrary, as the morning was stormy, I am inclined to think with Dr. Burney, that there is an error, and that it should be 28·75. In looking over my observations for the last eight years, I find that the barometer has sometimes stood as high as 30·0 during a storm, but this is unusual.

I am of opinion that the observations are most valuable, when taken simultaneously. I am also of opinion, that it would tend materially to elucidate Meteorological Science, if some scientific person in Scotland† would undertake to make observation simultaneously with us. I understand the thermometer in Scotland, a week or two since, was as low as 16.

Boston, 25th Dec. 1824.

Yours &c. SAMUEL VEALL.

to notice the following curious fact,—that when the kite on mounting very high acquired a different direction from getting into a different current of air, the wind usually blew from the same quarter on the earth's surface before the expiration of 24 hours. Thus the changes of the wind seem to take place first in the higher regions of the air, and are propagated downwards. I have confirmed this experiment, and established the fact, by the use of small air balloons, but the kite answers the purpose quite as well.

* See *Perennial Calendar*, or *Companion to the Almanack*. i. vol. 8vo. (Published by Harding and Co. Finsbury Square,) 1823, under Dec. 12.

† See a Meteorological Register for 1823, in our present Number, kept in the northernmost part of Scotland.

LIST OF NEW PATENTS.

To Louis Lambert, of No. 10, Rue de la Goût, Paris, and 29, Cannon-street, London, for improvements in the material and manufacture of paper.—Dated 23d of November 1824.—6 months to enrol specification.

To Stephen Wilson, of Streatham, Surry, esquire, who, in consequence of communications made to him by a certain foreigner residing abroad, is in possession of a new manufacture of stuffs with transparent and coloured figures called “Diaphane Stuffs.”—25th November.—6 months.

To William Shelton Burnett, of New London-street, London, merchant, for certain improvements in ships’ tackle.—25th November.—6 months.

To John Osbaldeston, of Shire Brow within Blackburn, Lancashire, calico-weaver, for his improved method of making healds in the weaving of cotton, silk, woollen, &c.—29th November.—6 months.

To Thomas Hancock, of Goswell Mews, Goswell-street, Middlesex, patent cock manufacturer, for his method of making or manufacturing an article which may be in many instances substituted for leather, and be applied to various other useful purposes.—29th November.—6 months.

To William Furnival, of Anderton, Cheshire, salt-manufacturer, for certain improvements in the manufacture of salt.—4th December.—6 months.

To William Weston Young, of Newton Nottage, Glamorganshire, engineer, for certain improvements in manufacturing salt, part of which are applicable to other useful purposes.—4th December.—4 months.

To John Hillary Suwerkrop, of Vine-street, Minories, London, merchant, who, in consequence of a communication made to him by a certain foreigner residing abroad, is in possession of an apparatus or machine, which he denominates “A thermophore, or a portable-mineral or river-water bath and linen-warmer;” and also for other apparatus or machines connected therewith for filtering and heating water.—4th December.—2 months.

To George Wycherley, of Whitchurch, Salop, saddler, for improved methods of making saddles and side-saddles.—4th December.—6 months.

To Robert Dickenson, of Park-street, Southwark, Surry, for his improved air-chamber for various purposes.—7th December.—6 months.

To John Thompson, of Pembroke-place, Pimlico, and of London Steel-Works, Thames Bank, Chelsea, for his improved mode of making refined, or, what is commonly called, “cast-steel.”—9th December.—2 months.

To Robert Bowman, of Aberdeen, Scotland, chain-cable maker, for his apparatus for stopping, releasing, and regulating chain and other cables of vessels, which he denominates “elastic stoppers.”—9th Dec.—4 months.

To William Moulton, of Lambeth, Surry, engineer, for his improvement or improvements in working water-wheels.—9th December.—6 months.

To Sir William Congreve, of Cecil-street, Strand, Middlesex, baronet, for his improved gas-meter.—14th December.—6 months.

To Samson Davis, of Upper East Smithfield, Middlesex, gun-lock maker, for his improvements applicable to fire-arms.—18th Dec.—6 months.

To David Gordon, of Basinghall-street, London, esquire, for certain improvements in the construction of carriages or other machines to be moved or propelled by mechanical means.—18th December.—6 months.

To Samuel Roberts, of Parke Grange, near Sheffield, Yorkshire, silver-plater, for his improvement in the manufacture of plated goods of various descriptions.—18th December.—2 months.

To Pierre Jean Baptiste Victor Gosset, of Clerkenwell Green, Middlesex, for certain improvements in the construction of looms or machinery for weaving various sorts of cloths or fabrics.—18th December.—6 months.

To Joseph Gardner, smith, and John Herbert, carpenter, both of Stanley St. Leonards, Gloucestershire, for certain improvements on machines for shearing or cropping woollen cloths.—18th December.—2 months.

A METEORO-

Days of Month, 1824.	Gosport, at half-past Eight o'Clock, A.M.					Clouds.					Barometer, in Inches, &c.			Thermometer.			RAIN.		WEATHER.				
	Barom. in Inches, &c.	Thermo.	Temp. of Sp. Water.	Hygrom.	Wind.	Evapora- tion.	Rain near the Ground.	Cirrus.	Cirrostr.	Stratus.	Cumulus.	Cumulostr.	Nimbus.	Lond. 1 P.M.	Bost. 8 1/2 A.M.	LONDON.		LONDON.	BOSTON.	LONDON.	BOSTON.		
																8 A.M.	11 P.M.					8 A.M.	
Nov. 26	29.64	35	52.95	69	N.	1	1	1	29.81	29.50	37.43	40	39.0	Cloudy	Fine	
27	29.65	42	...	65	N.E.	0.14	0.010	1	1	1	...	1	...	29.70	29.63	39.43	37	41	Fair	Cloudy	
28	29.70	52	...	70	SW.390	...	1	1	...	1	...	29.65	29.40	50.54	52	48	Cloudy	Rain	
29	29.24	50	...	72	SW.070	...	1	1	...	1	...	29.30	29.90	50.50	42	47	Fair	Fine, brisk S. wind	
30	29.50	50	...	72	SW.	...	1.060	...	1	1	...	1	...	29.33	29.25	46.54	50	42	Rain	Cloudy, rain a.m. and [p.m.]	
Dec. 1	29.32	44	52.60	68	N.W.	1	1	1	29.44	29.05	40.41	33	40.5	Rain	Fine, rain and snow [p.m.]	
2	29.59	38	...	71	S.975	...	1	1	...	1	...	29.55	29.40	32.43	40	33	Fair	Fine	
3	29.43	38	...	71	N.W.090	...	1	1	...	1	...	29.57	29.25	36.40	35	33	Fair	Fine	
4	29.41	42	...	72	NE.290	...	1	1	...	1	...	29.40	29.50	35.39	42	33	Cloudy	Snow	
5	29.44	41	...	73	N.	1	1	1	29.73	29.45	37.41	32	36.5	Cloudy	Cloudy, rain early a.m.	
6	29.80	33	52.30	74	W.200	...	1	1	...	1	...	29.65	29.65	30.40	43	28.5	Fair	Fine, rain p.m.	
7	29.54	42	...	71	N.W.	1	1	1	29.55	29.25	38.42	37	37	Fair	Cloudy	
8	29.86	41	...	72	W.040	...	1	1	...	1	...	29.85	29.63	38.45	42	39	Cloudy	Cloudy, rain p.m.	
9	29.74	43	...	74	W.415	...	1	1	...	1	...	29.70	29.54	42.38	30	36	Cloudy	Fine	
10	29.86	32	...	72	N.W.	1	1	1	30.05	29.70	32.38	30	29.5	Fair	Fine	
11	30.08	45	...	78	SW.	1	1	1	30.15	29.85	40.45	46	38	Cloudy	Cloudy	
12	30.25	47	...	75	W.	1	1	1	30.31	29.95	46.50	47	48.5	Fair	Fine	
13	30.40	48	52.00	73	W.	1	1	1	30.45	30.12	47.47	46	45	Cloudy	Fine	
14	30.44	49	...	76	SW.020	...	1	1	...	1	...	30.42	30.16	46.49	47	42	Fair	Fine	
15	30.10	48	...	77	W.090	...	1	1	...	1	...	30.02	29.30	47.49	49	43	Fair	Fine	
16	29.93	45	...	75	N.	1	1	1	29.95	29.72	44.43	37	35	Fair	Fine	
17	30.05	45	...	75	W.120	...	1	1	...	1	...	30.07	29.77	37.43	43	41.5	Rain	Cloudy	
18	30.14	49	...	79	W.04	...	1	1	...	1	...	30.17	29.95	43.49	49	42	Cloudy	Rain	
19	30.12	49	52.00	79	W.020	...	1	1	...	1	...	30.09	29.77	49.51	49	48	Fair	Cloudy	
20	29.45	51	...	82	SW.110	...	1	1	...	1	...	29.47	29.02	51.47	35	50.5	Stormy	Cloudy, brisk wind fr. [the S.]	
21	29.49	48	...	75	SW.200	...	1	1	...	1	...	29.39	29.10	43.51	50	43	Rain	Cloudy, strong g SW.	
22	29.04	51	...	79	SW.160	...	1	1	...	1	...	28.90	28.70	50.51	35	50	Stormy	Rain	
23	29.77	35	...	68	N.W.180	...	1	1	...	1	...	29.94	29.52	32.37	33	32	Fair	Fine	
24	29.51	48	...	82	SW.025	...	1	1	...	1	...	29.60	29.16	43.45	42	41	Stormy	Rain	
25	29.62	52	51.80	80025	...	1	1	...	1	...	29.55	29.22	47.55	55	52	Cloudy	Cloudy	
Averages:	29.737	44.43	52.27	73.9	...	1.10	4.490	18	7	26	7	9	7	22	29.75	29.38	42	42	40.46	2.90	2.92	2.90	2.92

INDEX TO VOL. LXIV.

- ALHIDADE,** 25
Ammonia, its action on copper, 72
Analyses of American Brine-springs, 74; Essonite, 150; Pinite, *ibid*; Camphor, 151; Holywell water, 394; fused charcoal, 467
Antiquities, 209, 273, 316
Arbury Hill, latitude of, 140
Architecture, Gothic, 273
Astronomical information, 67, 68, 378
Astronomical observations, Bessel's, 17, 102, 170, 249, 341, 415
Atkinson, (J.) on the plants of Yorkshire, 211
Bakewell, (R.) on Lava found at Boulogne, 414
Barlow, (Prof.) on the local attraction of vessels, 283
Barometric and pluviometric observations, 208
Becquerel, (M) his electro-motive researches, 401
Bell, analysis of his papers on the nerves, 41, 119, 353, 442
Bellani, on shooting stars, 294
Beryl, 468
Berzelius, (Prof.) on Silicium and Zirconium, 392
Bessel, Introduction to his Astronomical Observations, 17, 102, 170, 249, 341, 415
Bessel's Meridian Circle, 67
Bevan, (B) on the heights of stations in the Trigonometrical Survey, 140
Binomial Theorem, 270
Biot, (M.) on the pendulum, 161
Birds, migration of 50, 91
Bog, disruption of, 229
Bolides, on their general nature, 289
Books, new, 62, 143, 218, 304, 371, 457
Brandes, on shooting stars, 294
Brayley, (E. W.) on the progress of science respecting igneous meteors, and meteorites, in 1823, 111, 287
Brine-springs, 74
Buds, theory of, 82
Burney, (Dr.) Meteorological observations, 208; on the Meteorological Register, 370
Calculus of variations, 330
Calendar of Flora, Fauna, and Pomona, 77, 157, 238, 318, 397, 470
Camphor, analysis of, 151
Campo Santo, of Pisa, Gothic ornaments of, 273
Carriages, on the wheels and springs of, 394
Celery, early, 237
Chalk formation in America, 469
Charcoal, said to be fused, 467
Chemical contributions, 321
Combustion, electricity of, 409
Comet,
Conybeare, (W. D.) on Ichthyosaurus and Saurocephalus, 414
Cooper, on solar time, 210
Copper sheeting, method of preserving, 30, 233
Crystals, contractions of by heat, 152; axes of double refraction in, 162
Daniell's Meteorological Essays, review of, 218
Davy, (Sir H.) on the preservation of Copper Sheetting of ships, 30, 233
Decimal notation, 303, 362
Dæbereiner, on conversion of oxalate and formiate of ammonia into hydrocyanic acid, 234; his new mode of producing fire, 3
Earthquakes, 233, 315
Egyptian Antiquities, 316
Electro-chemistry, 7, 401
Electro-Magnetism, 242
Enalio Sauri, 409
Encke planet, 178
Engine, explosive, 154
Equations, functional, solution of, 197, 333
Essonite, analysis of, 150
Euclid. On his Twelfth Book, 181
Evans, (Rev. L.) Demonstration of Newton's Binomial Theorem, 270
Explosive Engine, 154
Farey, (J.) on the velocity of sound, 178; on the Encke planet, 180; on shooting stars, *ib.*
Fire-balls, on their general nature, 289
Flames, electricity of, 406
Flora, English, (Sir J. E. Smith's,) 226, 339

- Forster*, (Dr. T.) calendar of Flora, 77, 157, 238, 318, 397, 470; his atmospheric researches, 294; on shooting stars, *ib.*
Fossils, 315, 316, 389, 390, 409
Fothergill, (W.) on the toad, 85
Fruits, how affected by pollen, 191
Fruit-trees, effects of age on, 194
Galbraith, (W.) on the pendulum, 161
Ganges, geology of, 149
Gases, specific heat of, 200, 262; pump for compressing, 12, 129, 441
Geodetical problem, solution of, 35
Geology of the Ganges and Jumna, 149
Gilbert, (D.) on the wheels and springs of carriages, 394
Glanders, cure of, 235
Glass, its impermeability to water under high pressure, 72
Glosterian, on mean solar time, 295
Gmelin, (Prof.) analysis of two minerals, 150
Gübel, (Dr.) analysis of camphor, 151
Gooseberry plant, 236
Gothic ornaments of the Duomo, &c. at Pisa, 273
Granite columns, 470
Greenwich observations, inconsistencies in, 367, 451
Groombridge, (S.) R. A. and Declin. of four minor planets, 359
Gunn, (Rev. W.) on Gothic architecture, 273, 282
Harlan, (Dr.) on Saurocephalus, 409
Hart, (J.) on Light produced by an air-gun, 8
Haworth, (A. H.) on succulent plants, 184, 298; on *Mesembryanthema*, 61, 109, 423
Haycraft, (Wm.) on the specific heat of gases, 200, 262
Heights of stations in the trigonometrical survey, 140
Herapath, (John) on functional equations, 197
Herapath, (W.) chemical contributions, 321
Herrings, shower of? 152
Hibernation, 52, 89
Ichthyosaurus, 409, 413
Ivory, (J.) solution of a geodetical problem, 35
Jenner, (Dr.) on the migration of birds, 50, 91
Jumna, geology of, 149
Jupiter, occultation of, 465
Kater's pendulum, 161
Krusenstern, (Admiral) on the local attraction of vessels, 283
Knight, (T. A.) on the influence of the pollen on plants, 191; effects of age on fruit-trees; new varieties of Nectarines, 194
Latitude, on finding, 351
Lava found at Boulogne, 414
Lecount, (P.) tables of mean time of passage of stars over the meridian, 428
Lectures, 298
Lee, (S.) on the Greenwich observations, 367, 451
Lindley, (J.) on the vegetable physiology of *M. du Petit Thouars*, 81, 146, 228, 456
Logan Rock, 313, 383
Lunar Tables, new, 68
Lyceum of New York, annals of, 76
Martineau, (J.) on a hydro-pneumatic pump, 111
Mean Solar Time, 295, 350
Mean time of stars passing the meridian, 428
Measures, new, 302, 362
Meridian Circle, Bessel's, 67
Mesembryanthemum, new species of, 61, 109, 443
Meteorology, 80, 111, 155, 160, 180, 237, 240, 287, 317, 320, 380, 400, 431, 471
Meteorological Essays and Observations, review of, 218
Meteors, Igneous, progress of science respecting in 1823, 111, 287
Meteorites, progress of science respecting in 1823, 111, 287
Meteors seen in America, 113, in France, 118, in Martinique, 292, in Sussex, 293, at Islington, 294
Migration of birds, 50, 91
Minerals, American cabinet of, 390
Natural History, works on, 63, 146, 227, 373; neglect of, by the British government, 71
Nectarines, new varieties of, 194
Nerves, on the structure of, 41, 119, 442
Nerves, optic, semi-decussation of, 134
New South Wales, 211
Newton's, (Sir I.) Binomial Theorem, demonstration of, 270
Nitric acid and charcoal, action of, 393
Northern Expedition, 383
Odontalgia, and carious teeth, local causes of, 236
Oxalate and Formiate of Ammonia, 234
Oxygen, combinations of, 322
Parke, (Mungo) 209
Parly's rifle rockets, 75, 154
Patents, 79, 159, 239, 318, 398, 472
Pendulum, 161
Pinite, analysis of, 150
Planets, the four minor, R. A. and Decl. of, 359
Plants, geographical distribution of in Yorkshire, 211
Pollen, influence of on plants, 191
Pollock, (T.) on the voltaic pile, 129

- Pump*, a hydro-pneumatic, for compressing gases, &c. 12, 129, 441
- Refraction*, 255
- Respiration*, nerves of, 42, 119
- Review of books*, 226, 218
- Reviews*, misrepresentations of, 227, 339
- Rüchle*, (J.) the late African traveller, letter from, 69
- Rockets*, rifle, 75, 154
- Scholz*, on selenium, and tellurium, 83
- Schweigger*, (Dr.) on Döbereiner's new mode of producing fire, 3
- Seal*, a tame one, 236
- Seaward*, on a hydro-pneumatic pump, 12, 129, 441
- Selenium*, 83
- Sexual impulse*, in birds, 56, 101
- Shooting stars*, 180, 294
- Silicium*, 392
- Smith*, (Sir J. E.) on vegetation, 241, 456; his English Flora, on a review of, 226, 339
- Smith*, (M.) on finding the latitude by the altitudes of two stars, 351; on mean solar time, 350
- Society*, Royal French Academy, 65, 148, 205, 381, 466; Horticultural, 147, 377; Native Calcutta, 149; Caen, 238; Academy of Sciences of Copenhagen, 207; Royal Academy of Brussels, 208; Royal, 374, 459; Linnæan, 374, 463; Geological, 375, 463; Astronomical, 378, 464; London Mechanics' Institution, 380
- Sound*, the velocity of, 178
- Steel*, method of cutting by soft iron, 73
- Sturgeon*, (W.) on Electro-Magnetism, 242
- Stars*, circumpolar, 249
- Succulent plants*, new, 184, 298
- Taylor*, (Arthur) on the Gothic ornaments of the Duomo, &c. of Pisa, 273
- Tea*, adulteration of, 151
- Tellurium*, odour of, 83
- Telescope*, flexure of, 170
- Thenard*, (M.) on Döbereiner's experiment, 10
- Thouars*, du Petit, vegetable physiology, 81, 228, 456
- Tiarks's* (Dr.) trigonometrical surveys, 233
- Tiarks*, (Dr.) on his tables for solar time, 211, 350
- Time*, mean solar, 210
- Titanium*, metallic, 392
- Toad*, natural history of, 85
- Tourmaline*, 463
- Tredgold*, (T.) on weights and measures, 302, 362
- Trona Lake*, 387
- Trumpeter bird* a ventriloquist, 469
- Vanuxem*, (L.) on fused charcoal 467
- Veall*, (Mr.) meteorological observations, 237, 370, 471
- Vegetable physiology of M. du Petit Thouars*, 81, 241, 456
- Vegetation*, theories of Sir J. E. Smith and M. du Petit Thouars, 241, 456
- Vessels*, local attraction of, 283
- Voltaic pile*, action of, 7, 32, 129
- Walsh*, (J.) on the Twelfth book of Euclid, 181; on the calculus of variations, 330
- Wasps*, absence of, 234, 238
- Water-spout*, effects of, 152
- Water*, its electro-motive action on metals, 401
- Webster*, (Mr.) geolog. observations, 375
- Weights and Measures*, 302, 362
- Wollaston*, (Dr.) on the semi-decussation of the optic nerves, 134
- Woolnoth*, (J. C.) analysis of Holywell water, 394
- Yorkshire*, plants in, 211
- Zirconium*, 392

END OF THE SIXTY-FOURTH VOLUME.



LONDON:

PRINTED BY RICHARD TAYLOR, SHOE-LANE.

1824.

a few Days, with an original Portrait, Explanatory Engravings, 12mo,

THE CENTURY of INVENTIONS of the MARQUIS of WORCESTER, from the original MSS., with Historical and Explanatory Notes, and a Biographical Memoir.

By CHARLES F. PARTINGTON,
of the London Institution,

Author of an Historical and Descriptive Account of the Steam Engine, &c. &c.

“A practical mathematician who has quickness to seize a hint, and sagacity to apply it, might avail himself greatly of these scantlings. It is extremely probable, that Savery took from the Marquis the hint of the Steam Engine, for raising water with a power made by fire, which invention alone would entitle the author to immortality.”—*Grang. Biog. Hist.* vol. v. p. 278.

“Here it may not be amiss to recommend to the attention of every mechanic, the little work entitled a *Century of Inventions*, by the Marquis of Worcester, which, on account of the seeming improbability of discovering many things mentioned therein, has been too much neglected: but when it is considered that some of the contrivances, apparently not the least abstruse, have, by close application, been found to answer all the Marquis says of them, and that the first hint of that most powerful machine the steam engine is given in that work, it is unnecessary to enlarge on the utility of it.”—*Trans. of the Society of Arts*, vol. iii. p. 6.

Printed for John Murray, Albemarle-street.

ENGRAVINGS.

Vol. LX. A Plate illustrative of Mrs. IBBETSON's Paper On the Pollen of Flowers.—A Plate illustrative of a Paper by Mr. R. TAYLOR, of Norwich, on Fossil Bones from the Norfolk Coast.—A Plate illustrative of a Paper by F. BAILY, Esq. on the Stars forming the Pleiades.—A Plate illustrative of Prof. AMICI's New Sextant.

Vol. LXI. Engravings—1. Illustrative of Mr. TREDGOLD's Paper on the Flexure of Astronomical Instruments.—2. DEURBROUCC and NICHOLS' Apparatus for Madame GERVAIS' New Method of Fermentation.—A Plate illustrative of Mr. R. TAYLOR's Geological Section of Hunstanton Cliff, Norfolk.—A Plate illustrative of Mr. TATUM's Communication on Electro-Magnetism.

Vol. LXII. A Plate illustrative of Professor HARE's Communications on Electricity, and on the Self-acting Blowpipe.—A Plate illustrative of Mr. BRUNEL's new Mode of Tunnelling, and of his Proposal for a Roadway under the Thames.—A Plate illustrative of M. BECQUEREL's Experiments on the Development of Electricity by Pressure.—A Plate illustrative of Mr. BARLOW's Experiments on Mr. MARSH's Thermo-Electric Apparatus.—A Plate illustrative of Mr. SEAWARD's Observations on Suspension Chain Bridges.

Vol. LXIII. A Plate illustrative of Mr. GOMPERTZ's Method of defending Ships and Fortifications; and a Cut of Mr. SEAWARD's Pressure Gauge.—A Plate illustrative of Mr. RICHARD TAYLOR's Paper on the Upper Marine Formation in the Cliffs near Cromer.—A Plate illustrative of Dr. WALCHNER's Examination of a new Mineral named Hyalosiderite; and of Mr. BAILY's and M. FRAUENHOFER's Accounts of the Circular Micrometer.—A Plate illustrative of Professor HARE's Single-leaf Electrometer and improved Deflagrators.—A Plate containing two new Species of *Ascidia*; and *Amphiuma means*, a new Batrachian Animal.

Vol. LXIV. A Plate illustrative of Mr. S. SEAWARD's Hydro-Pneumatic Pump for compressing Gases.

CONTENTS OF NUMBER 316.

XII. The Theory of Vegetable Physiology of M. AUBERT DU PETIT THOUARS ; or of the Increase of Plants by means of Buds, or fixed Embryos. By JOHN LINDLEY, Esq.	page 81
XIII. On the Extraction of Selenium from the Residuum of the Sulphuric Acid Works of Lukawitz in Bohemia; and on the Cause of the Odour of Tellurium. By Professor SCHOLZ, of the Polytechnic Institution of Vienna	83
XIV. Hints towards the Natural History of the Toad. By WM. FOTHERGILL, Esq.	85
XV. Some Observations on the Migration of Birds. By the late EDWARD JENNER, M.D. F.R.S.; with an Introductory Letter to Sir HUMPHRY DAVY, Bart. Pres. R.S., by the Rev. G. C. JENNER. .	91
XVI. Introduction to the Seventh Section of BESSEL'S Astronomical Observations	102
XVII. An Account of the <i>Mesembryanthema Ringentia</i> . By A. H. HAWORTH, Esq. F.L.S. &c.	109
XVIII. A Sketch of the Progress of Science respecting Igneous Meteors and Meteorites during the Year 1823; including an Account of the principal Phenomena of that Nature observed during the same Period: with Inquiries suggested by those Subjects. By E. W. BRAYLEY, junior, A.L.S., and Member of the Meteorological Society ..	111
XIX. Analyses of a Series of Papers on the Structure, Distribution, and Functions of the Nerves; by CHARLES BELL, Esq.; which have appeared in some late Volumes of the Philosophical Transactions. .	119
XX. On Mr. SAMUEL SEAWARD'S Claim to the Invention of a Hydro-pneumatic Pump for compressing Gases, &c. By JOHN MARTINEAU, Esq.	129
XXI. An Attempt to explain the Action of the Voltaic Pile. By Mr. THOMAS POLLOCK.	129
XXII. Of Semi-decussation of the Optic Nerves. By WILLIAM HYDE WOLLASTON, M.D. V.P.R.S.	134
XXIII. Observations on the Heights of Places in the Trigonometrical Survey of Great Britain, and upon the Latitude of Arbury Hill. By B. BEVAN, Esq.	140
XXIV. Notices respecting New Books:—Transactions of the Horticultural Society for 1824; Analysis of Periodical Works on Natural History.	141
XXV. Proceedings of Learned Societies:—Horticultural Society; Royal Academy of Sciences of Paris; and Calcutta Native Society. .	147
XXVI. Intelligence and Miscellaneous Articles:—Geology of the Ganges and Jumna; Analyses by Prof. Gmelin of Tubingen; Adulteration of Tea; New Analysis of Camphor, by Dr. Göbel; Contractions produced by Heat in Crystals; Direction of the Axes of double Refraction in Crystals; Supposed Effects of a Water-spout; Explosive Engine; Rifle Rockets; Rain, and Height of the Barometer in May; Calendar of Flora, Fauna, and Pomona, at Hartfield in Sussex, from July 19 to August 13; List of New Patents; Meteorological Table.	149—160

** Communications for this Work, received by the Editors, 38 Shoe-Lane, will meet with every attention.

ENGRAVINGS.

Vol. LVIII. A Plate illustrative of Mr. GEO. INNES's Calculations of the Annular Eclipse of the Sun, which will happen on the 15th of May 1836.—A Plate descriptive of the Hydrostatic Balances of ISAAH LUKENS and Dr. COATES.—A Plate illustrative of "An Introduction to the Knowledge of Funguses."—A Plate illustrative of Professor DAVY's Lactometer, and of Mr. JOHN MURRAY's portable Apparatus for restoring the Action of the Lungs.—A Plate by PORTER, illustrative of Mr. SCHOOLCRAFT's Account of the Native Copper on the Southern Shore of Lake Superior; and of Dr. MILLAR's Observations and Experiments on the Rose of Jericho. With a PORTRAIT of the EDITOR, engraved by THOMSON from a Painting by FRAZER; and a Plate by PORTER, illustrative of Mr. LEESON's Appendage to TOFFI's Blowpipe.

Vol. LIX. A Plate illustrative of Mrs. IBBETSON's Paper On the Flower-buds of Trees passing through the Wood.—A Plate descriptive of the Instruments employed in determining Altitudes from the Trigonometrical Station on Rumbles Moor, Yorkshire.—A Plate illustrative of Mr. IVORY's Theory of Parallel Lines in Geometry; Mr. LEESON's Safety Blowpipe Appendages; Mr. MOORE's new Apparatus for restoring the Action of the Lungs in Cases of suspended Respiration; and Dr. READE's Communication on Refraction.—A Plate illustrative of a curious Electro-magnetic Experiment by Mr. BARLOW; and Mrs. IBBETSON's Paper on the Perspiration alleged to take place in Plants.—A Plate illustrative of Mr. MARSH's Paper on a particular Construction of M. AMPERE's Rotating Cylinder.

Vol. LX. A Plate illustrative of Mrs. IBBETSON's Paper On the Pollen of Flowers.—A Plate illustrative of a Paper by Mr. R. TAYLOR, of Norwich, on Fossil Bones from the Norfolk Coast.—A Plate illustrative of a Paper by F. BAILY, Esq. on the Stars forming the Pleiades.—A Plate illustrative of Prof. AMICI's New Sextant.

Vol. LXI. Engravings—1. Illustrative of Mr. TREGOLD's Paper on the Flexure of Astronomical Instruments.—2. DEURBROUCQ and NICHOLS' Apparatus for Madame GERVAIS' New Method of Fermentation.—A Plate illustrative of Mr. R. TAYLOR's Geological Section of Hunstanton Cliff, Norfolk.—A Plate illustrative of Mr. TATUM's Communication on Electro-Magnetism.

Vol. LXII. A Plate illustrative of Professor HARE's Communications on Electricity, and on the Self-acting Blowpipe.—A Plate illustrative of Mr. BRUNEL's new Mode of Tunnelling, and of his Proposal for a Roadway under the Thames.—A Plate illustrative of M. BECQUEREL's Experiments on the Development of Electricity by Pressure.—A Plate illustrative of Mr. BARLOW's Experiments on Mr. MARSH's Thermo-Electric Apparatus.—A Plate illustrative of Mr. SEAWARD's Observations on Suspension Chain Bridges.

Vol. LXIII. A Plate illustrative of Mr. GOMPERTZ's Method of defending Ships and Fortifications; and a Cut of Mr. SEAWARD's Pressure Gauge.—A Plate illustrative of Mr. RICHARD TAYLOR's Paper on the Upper Marine Formation in the Cliffs near Cromer.—A Plate illustrative of Dr. WALCHNER's Examination of a new Mineral named Hyalosiderite; and of Mr. BAILY's and M. FRAUENHOFER's Accounts of the Circular Micrometer.—A Plate illustrative of Professor HARE's Single-leaf Electrometer and improved Deflagrators.—A Plate containing two new Species of *Ascidia*; and *Amphiuma means*, a new Batrachian Animal.

Vol. LXIV. A Plate illustrative of Mr. S. SEAWARD's Hydro-pneumatic Pump for compressing Gases.

CONTENTS OF NUMBER 318.

XL I. On the Theories of Vegetation of Sir J. E. SMITH and M. DU PETIT-THOUARS	page 241
XLII. On Electro-Magnetism. By Mr. W. STURGEON.	242
XLIII. Introduction to the Seventh Section of BESSEL'S Astronomical Observations. (<i>Continued.</i>)	249
XLIV. On the Specific Heat of the Gases. By W. T. HAYCRAFT, Esq. (<i>continued.</i>)	262
XLV. An improved Demonstration of Sir ISAAC NEWTON'S Binomial Theorem, on Fluxional Principles, more especially calculated for the young Student in Mathematics. By the Rev. Mr. L. EVANS, F.R.S. and A.S. &c.	270
XLVI. Remarks on the Gothic Ornaments of the Duomo, Battistero, and Campo Santo, of Pisa. By ARTHUR TAYLOR, Esq. F.S.A., Member of the Roman Academy of Arcadians.	273
XLVII. On the Local Attraction of Vessels. In a Letter from Admiral KRUSENSTERN of the Imperial Russian Navy to PETER BARLOW, Esq. F.R.S.	283
XLVIII. A Sketch of the Progress of Science respecting Igneous Meteors and Meteorites during the Year 1823; including an Account of the principal Phænomena of that Nature observed during the same Period: with Inquiries suggested by those Subjects. By E. W. BRAYLEY, junior, A.L.S., and Member of the Meteorological Society (<i>continued.</i>)	287
XLIX. Reply to Mr. SAMUEL COOPER'S Queries on finding the exact Mean Solar Time	295
L. <i>Decas secunda novarum Plantarum Succulentarum</i> ; A second Decade of New Succulent Plants. By A. H. HAWORTH, Esq. F.L.S. &c.	298
LI. On the Weights and Measures. By Mr. THOS. TREGGOLD	302
LII. Notices respecting New Books.	304
LIII. Proceedings of Learned Societies:—of France, Copenhagen, and Brussels.	305-308
LIV. Intelligence and Miscellaneous Articles:—The Comet; The Discovery Ships; Antiquities; Mungo Park.—Africa; New South Wales; The Logan Rock; Earthquakes; Meteor and Earthquake; Fossils; Fossil Elephant; Egyptian Antiquities; Meteorological Observations at Great Yarmouth, by C. G. HARLEY, Esq.; Calendar of Flora, Fauna, and Pomona; New Patents; Meteorological Table	309—320

* * * Communications for this Work, received by the Editors, 38 Shoe-Lane, will meet with every attention.

PHARMACOPŒIA LONDINENSIS,
Iterum recognita et retractata, 1824, p. 6.
"ACIDUM ACETICUM FORTIUS,"
vel
"Acidum Aceticum è Ligno destillatum."

PURE CONCENTRATED ACETIC ACID, agreeable to the Sample furnished at the request of the Committee of the Royal College of Physicians, may be had of the Manufacturers, BEAUFOY & CO. South Lambeth, London.

ENGRAVINGS.

Vol. LIX. A Plate illustrative of Mrs. IBBETSON'S Paper On the Flower-buds of Trees passing through the Wood.—A Plate descriptive of the Instruments employed in determining Altitudes from the Trigonometrical Station on Rumbles Moor, Yorkshire.—A Plate illustrative of Mr. IVORY'S Theory of Parallel Lines in Geometry; Mr. LEESON'S Safety Blowpipe Appendages; Mr. MOORE'S new Apparatus for restoring the Action of the Lungs in Cases of suspended Respiration; and Dr. READE'S Communication on Refraction.—A Plate illustrative of a curious Electro-magnetic Experiment by Mr. BARLOW; and Mrs. IBBETSON'S Paper on the Perspiration alleged to take place in Plants.—A Plate illustrative of Mr. MARSH'S Paper on a particular Construction of M. AMPERE'S Rotating Cylinder.

Vol. LX. A Plate illustrative of Mrs. IBBETSON'S Paper On the Pollen of Flowers.—A Plate illustrative of a Paper by Mr. R. TAYLOR, of Norwich, on Fossil Bones from the Norfolk Coast.—A Plate illustrative of a Paper by F. BAILY, Esq. on the Stars forming the Pleiades.—A Plate illustrative of Prof. AMICI'S New Sextant.

Vol. LXI. Engravings—1. Illustrative of Mr. TREGOLD'S Paper on the Flexure of Astronomical Instruments.—2. DEURBROUCQ and NICHOLS' Apparatus for Madame GERVAIS' New Method of Fermentation.—A Plate illustrative of Mr. R. TAYLOR'S Geological Section of Hunstanton Cliff, Norfolk.—A Plate illustrative of Mr. TATUM'S Communication on Electro-Magnetism.

Vol. LXII. A Plate illustrative of Professor HARE'S Communications on Electricity, and on the Self-acting Blowpipe.—A Plate illustrative of Mr. BRUNEL'S new Mode of Tunnelling, and of his Proposal for a Roadway under the Thames.—A Plate illustrative of M. BECQUEREL'S Experiments on the Development of Electricity by Pressure.—A Plate illustrative of Mr. BARLOW'S Experiments on Mr. MARSH'S Thermo-Electric Apparatus.—A Plate illustrative of Mr. SEAWARD'S Observations on Suspension Chain Bridges.

Vol. LXIII. A Plate illustrative of Mr. GOMPERTZ'S Method of defending Ships and Fortifications; and a Cut of Mr. SEAWARD'S Pressure Gauge.—A Plate illustrative of Mr. RICHARD TAYLOR'S Paper on the Upper Marine Formation in the Cliffs near Cromer.—A Plate illustrative of Dr. WALCHNER'S Examination of a new Mineral named Hyalosiderite; and of Mr. BAILY'S and M. FRAUENHOFER'S Accounts of the Circular Micrometer.—A Plate illustrative of Professor HARE'S Single-leaf Electrometer and improved Deflagrators.—A Plate containing two new Species of *Ascidia*; and *Amphiuma means*, a new Batrachian Animal.

Vol. LXIV. A Plate illustrative of Mr. S. SEAWARD'S Hydro-pneumatic Pump for compressing Gases.—A Plate illustrative of Mr. STURGEON'S Electro-Magnetic Rotating Apparatus; and of Mr. HAYCRAFT'S Apparatus for ascertaining the Specific Heat of Gases.

CONTENTS OF NUMBER 319.

LV. Contributions to our Knowledge of Chemical Bodies. By Mr. W. HERAPATH.....	page 321
LVI. On the Calculus of Variations. By JOHN WALSH, Esq.	330
LVII. On the Transformation of the Solutions of a Periodical Functional Equation. By JOHN HERAPATH, Esq.	333
LVIII. Statement on the part of the Monthly Critical Gazette respecting the Review of Sir J. E. SMITH's English Flora in that Publication. By A CORRESPONDENT.	339
LIX. Introduction to the Seventh Section of BESSEL's Astronomical Observations. (<i>Continued.</i>)	341
LX. On finding the exact Mean Solar Time. By M. SMITH, Esq.	350
LXI. On finding the Latitude by the Altitudes of two Stars. By M. SMITH, Esq.	351
LXII. Analyses of a Series of Papers on the Structure, Distribution, and Functions of the Nerves; by CHARLES BELL, Esq.; which have appeared in some late Volumes of the Philosophical Transactions. (<i>Continued.</i>)	353
LXIII. Apparent Right Ascension and Declination of the four Minor Planets, at and about their ensuing Opposition.	359
LXIV. On Weights and Measures, and on numerical Notations, in reply to Mr. TREGOLD. By DECAPHILUS.	362
LXV. On some extraordinary Inconsistencies in the Greenwich Observations for 1821. By S. LEE, Esq.	367
LXVI. On some Observations in the Meteorological Register. By W. BURNET, LL.D.	370
LXVII. Notices respecting New Books	371
LXVIII. Proceedings of Learned Societies:—Royal Society, Linneæan Society, Geological Society, Horticultural Society, and Astronomical Society; London Mechanics' Institution; and Royal Academy of Sciences of Paris.	374—383
LXIX. Intelligence and Miscellaneous Articles:—Northern Expedition; The Logan Rock replaced; Account of the Trona Lake in Africa; Discovery of Fossil Bones at Banwell; Organic Remains in Sussex; Cabinet of Minerals at Cambridge, United States; on Metallic Titanium; Prof. Berzelius on Silicium and Zirconium; Action of Nitric Acid and Charcoal; Analysis of the Holy-Well Water, near Cartmell, Lancashire; by J. C. WOOLNETH, Lieut. R.N.; Mr. D. GILBERT on the Springs and Wheels of Carriages; Calendar of Flora, Fauna, and Pomona; New Patents; Meteorological Table	383—400

* * * Communications for this Work, received by the Editors, 38 Shoe-Lane, will meet with every attention.

This day is published,

TRANS ACTIONS OF THE GEOLOGICAL SOCIETY, Part 2nd
Vol. I., Second Series; with twenty-five Plates, 4to. Price 2l. 2s.

May be had of the Booksellers, and at the House of the Society,
20, Bedford Street, Covent Garden.

PHARMACOPŒIA LONDINENSIS,

Iterum recognita et retractata, 1824, p. 6.

“ACIDUM ACETICUM FORTIUS,”

vel

“*Acidum Aceticum e Ligno destillatum.*”

PURE CONCENTRATED ACETIC ACID, agreeable to the Sample
furnished at the request of the Committee of the Royal College of
Physicians, may be had of the Manufacturers, BEAUFOY & CO. South
Lambeth, London.

ENGRAVINGS.

Vol. LX. A Plate illustrative of Mrs. IBBETSON's Paper On the Pollen
of Flowers.—A Plate illustrative of a Paper by Mr. R. TAYLOR, of Nor-
wich, on Fossil Bones from the Norfolk Coast.—A Plate illustrative of a
Paper by F. BAILY, Esq. on the Stars forming the Pleiades.—A Plate
illustrative of Prof. AMICI's New Sextant.

Vol. LXI. Engravings—1. Illustrative of Mr. TREDGOLD's Paper on
the Flexure of Astronomical Instruments.—2. DEURBROUCQ and NI-
CHOLS' Apparatus for Madame GERVAIS' New Method of Fermentation.
—A Plate illustrative of Mr. R. TAYLOR's Geological Section of Hun-
stanton Cliff, Norfolk.—A Plate illustrative of Mr. TATUM's Communi-
cation on Electro-Magnetism.

Vol. LXII. A Plate illustrative of Professor HARE's Communications
on Electricity, and on the Self-acting Blowpipe.—A Plate illustrative
of Mr. BRUNEL's new Mode of Tunnelling, and of his Proposal for a
Roadway under the Thames.—A Plate illustrative of M. BECQUEREL's
Experiments on the Development of Electricity by Pressure.—A Plate
illustrative of Mr. BARLOW's Experiments on Mr. MARSH's Thermo-
Electric Apparatus.—A Plate illustrative of Mr. SEAWARD's Observa-
tions on Suspension Chain Bridges.

Vol. LXIII. A Plate illustrative of Mr. GOMPERTZ's Method of de-
fending Ships and Fortifications; and a Cut of Mr. SEAWARD's Pressure
Gauge.—A Plate illustrative of Mr. RICHARD TAYLOR's Paper on the
Upper Marine Formation in the Cliffs near Cromer.—A Plate illustrative
of Dr. WALCHNER's Examination of a new Mineral named Hyalosiderite;
and of Mr. BAILY's and M. FRAUENHOFER's Accounts of the Circular
Micrometer.—A Plate illustrative of Professor HARE's Single-leaf Elec-
trometer and improved Deflagrators.—A Plate containing two new Spe-
cies of *Ascidia*; and *Amphiuma means*, a new Batrachian Animal.

Vol. LXIV. A Plate illustrative of Mr. S. SEAWARD's Hydro-pneu-
matic Pump for compressing Gases.—A Plate illustrative of Mr. STUR-
GEON's Electro-Magnetic Rotating Apparatus; and of Mr. HAYCRAFT's
Apparatus for ascertaining the Specific Heat of Gases.

CONTENTS OF NUMBER 320.

LXX. On the Electro-motive Actions of Water and Liquids in general on Metals: and of the electric Effects which take place—first, in the Contact of certain Flames and Metals; secondly, in Combustion. By M. BECQUEREL, Ancien Chief de Bataillon du Génie.	page 401
LXXI. On a new Fossil Genus, of the Order <i>Enalio Sauri</i> (of <i>Conybeare</i>): and on a New Species of <i>Ichthyosaurus</i> . By R. HARLAN, M.D.	409
LXXII. On Lava found on the Sands near Boulogne. By ROBERT BAKEWELL, Esq.	414
LXXIII. Introduction to the Seventh Section of BESSEL'S Astronomical Observations.	415
LXXIV. <i>Decas tertia novarum Plantarum Succulentarum</i> ; A third Decade of new Succulent Plants. By A. H. HAWORTH, Esq. F.L.S., &c.	423
LXXV. Tables for facilitating the Calculation of the Mean Time of the Passage of Stars over the Meridian; for the Use of those who observe by Clocks or Chronometers showing Mean Solar Time. Computed by Mr. P. LECOUNT.	428
LXXVI. Meteorological Register kept at WICK in the County of Caithness, near the Northern Extremity of Scotland, in the Year 1823.	431
LXXVII. On a Hydro-pneumatic Pump. By Mr. SAMUEL SEAWARD.	441
LXXVIII. Analyses of a Series of Papers on the Structure, Distribution, and Functions of the Nerves; by CHARLES BELL, Esq.; which have appeared in some late Volumes of the Philosophical Transactions. (<i>Concluded</i>).	445
LXXIX. On some extraordinary Inconsistencies in the Greenwich Observations for 1821. By S. LEE, Esq.	451
LXXX. Upon the System of Vegetable Physiology of M. AUBERT DU PETIT THOUARS: in Reply to Sir JAS. EDW. SMITH. By J. LINDLEY, Esq. F.L.S. &c.	456
LXXXI. Notices respecting New Books	457
LXXXII. Proceedings of Learned Societies:—Royal Society, Linnean Society, Geological Society, Astronomical Society; and Royal Academy of Sciences of Paris	459—467
LXXXIII. Intelligence and Miscellaneous Articles:—Account of an Examination of Fused Charcoal; by LARDNER VANUXEM; Existence of the Chalk Formation in North America; The Trumpeter-Bird a true Ventriloquist; Granite columns; Calendar of Flora, Fauna, and Pomona; New Patents; Meteorological Table	467—475

* * * Communications for this Work, received by the Editors, 38 Shoe-Lane, will meet with every attention.



